

TIP NO.	SHEET NO.
U-6003	SIGN-1
APPROVED: <i>Ron King</i>	
DATE: 9/13/2023	
SEAL	
	
DOCUMENT NOT CONSIDERED FINAL UNLESS ALL SIGNATURES COMPLETED	

**STATE OF NORTH CAROLINA
DEPARTMENT OF TRANSPORTATION**

**SIGNING PLAN
FORSYTH /GUILFORD COUNTIES**

**LOCATION: KERNERSVILLE – KERNERSVILLE LOOP
FROM SR 1969 (PINEY GROVE RD) TO NC 150
(N. MAIN ST.)**

INDEX

SHEET NO.	DESCRIPTION
SIGN-1	TITLE SHEET
SIGN-2	MOUNTING OF TYPE 'D', 'E' AND 'F' SIGNS ON 'U' CHANNEL POSTS (SHEET 2 OF 2)
SIGN-3	'E' & 'F' TYPE SIGNS
SIGN-4 & 5	SIGN DETAIL SHEETS

ROADWAY STANDARD DRAWING

THE FOLLOWING ROADWAY STANDARDS AS APPEAR IN "ROADWAY STANDARD DRAWINGS" - PROJECT SERVICES UNIT - N.C. DEPARTMENT OF TRANSPORTATION - RALEIGH, N.C., DATED JANUARY 2018 ARE APPLICABLE TO THIS PROJECT AND BY REFERENCE HEREBY ARE CONSIDERED A PART OF THESE PLANS:

STD. NO.	TITLE
904.10	ORIENTATION OF GROUND MOUNTED SIGNS
904.50	MOUNTING OF TYPE 'D', 'E' AND 'F' SIGNS ON 'U' CHANNEL POSTS (SHEET 1 OF 2)

SUMMARY OF QUANTITIES

ITEM NO.		ITEM DESCRIPTION	QUANTITY	UNIT
DESC. NO.	SECT. NO.			
4072000000	903	SUPPORTS, 3 LB STEEL U-CHANNEL	363	L.F.
4102000000	904	SIGN ERECTION, TYPE E	32	EA.
4108000000	904	SIGN ERECTION, TYPE F	2	EA.
4155000000	907	DISPOSAL OF SIGN SYSTEM, U-CHANNEL	13	EA.

GENERAL NOTES

- SIGNS FURNISHED BY STATE
- IF REMOVAL OR RELOCATION OF SIGNS ON PRIVATE STREET (NON-STATE MAINTAINED) IS REQUIRED DUE TO CONSTRUCTION, THE CONTRACTOR SHALL INFORM THE ENGINEER. THE WORK WILL BE COMPLETED BY OTHERS.
- WHEN NOT STATIONED OR DIMENSIONED ON PLANS, ALL 'E' AND 'F' SIGNS SHALL BE FIELD LOCATED BY THE ENGINEER
- ALL EXISTING SIGNS ON "U" CHANNEL POST WITHIN THE PROJECT LIMITS SHALL BE REMOVED AND DISPOSED OF UNLESS OTHERWISE NOTED ON PLANS.
- WHEN EXISTING SIGNS ARE REMOVED AND INSTALLED ON NEW SUPPORTS, THE RE-ERECTION SHALL IMMEDIATELY FOLLOW THE REMOVAL.
- THE BACKGROUND FOR TYPE E & F SIGNS SHALL BE GRADE C REFLECTIVE SHEETING.

T.I.P.: U-6003

CONTRACT: C204124

PLAN REVIEWED BY: N.C.D.O.T. SIGNING AND DELINEATION UNIT

<u>K. JORDAN</u>	SIGNING & DELINEATION REGIONAL ENGINEER
_____	SIGNING & DELINEATION PROJECT DESIGN ENGINEER

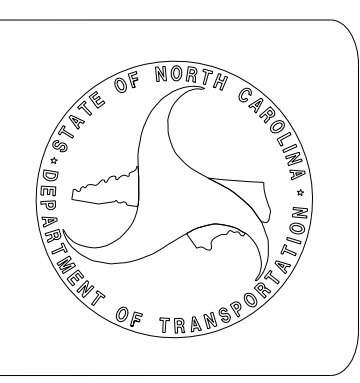

PLAN PREPARED BY: HDR/CA

<u>RON KING, P.E.</u>	PROJECT ENGINEER
<u>RICHARD DRAYTON</u>	DESIGN ENGINEER

HDR HDR Engineering, Inc. of the Carolinas
555 Fayetteville St, Suite 900 Raleigh, N.C. 27601
N.C.B.E.L.S. License Number: F-0116

07/24/23 P:\2024\Users\01\HDR_US_East_01\Documents\3322\102001461\10108594\6.0_CAD_BIM\6.2_Work_In_Progress\Traffic\Signing\CADD\Signing_Layout_Plans\U6003_sign_title.dgn User: HDR/HDR

TIP NO.	SHEET NO.
U-6003	DocuSigned by: SIGN-2
APPROVED:	<i>Matthew V. Springer</i>
DATE:	6/23/2021
SEAL	



STATE OF NORTH CAROLINA
DEPT. OF TRANSPORTATION
DIVISION OF HIGHWAYS
RALEIGH, N.C.

6-21

ENGLISH DETAIL DRAWING FOR
MOUNTING OF
TYPE 'D', 'E', AND 'F' SIGNS
ON 'U' CHANNEL POSTS

SHEET 1 OF 2
904D50

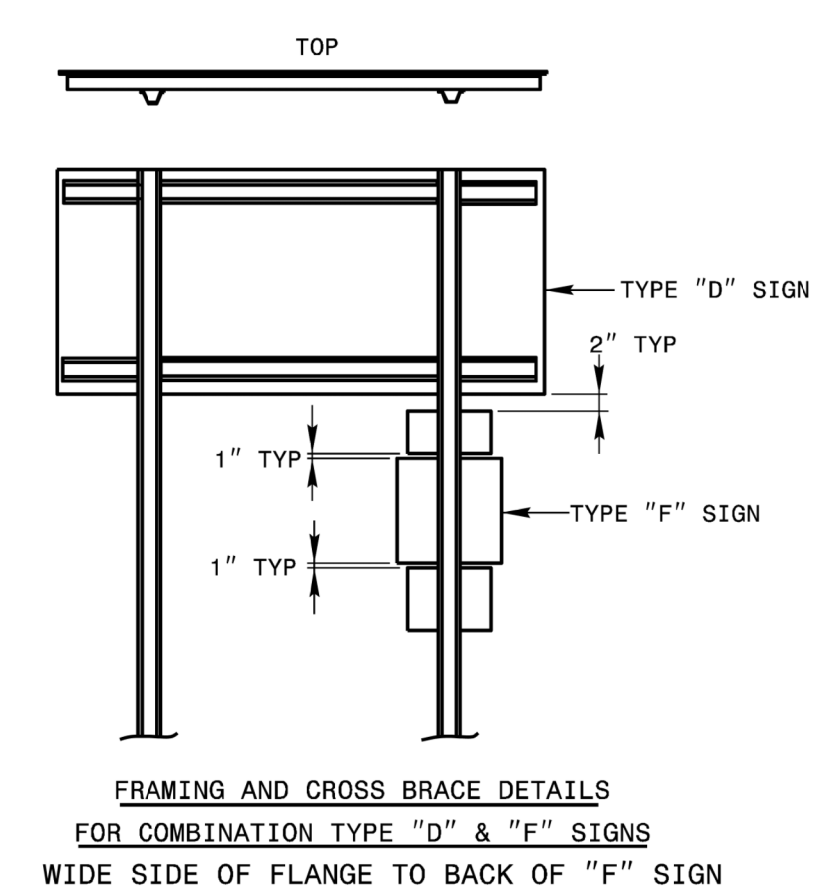
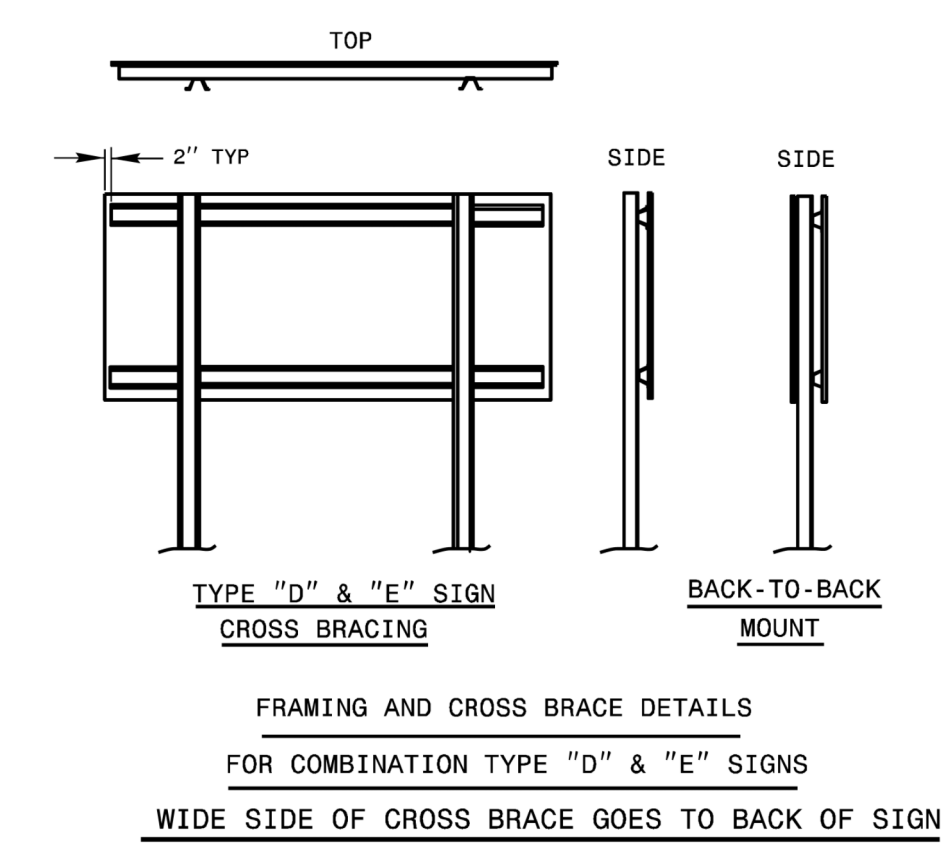
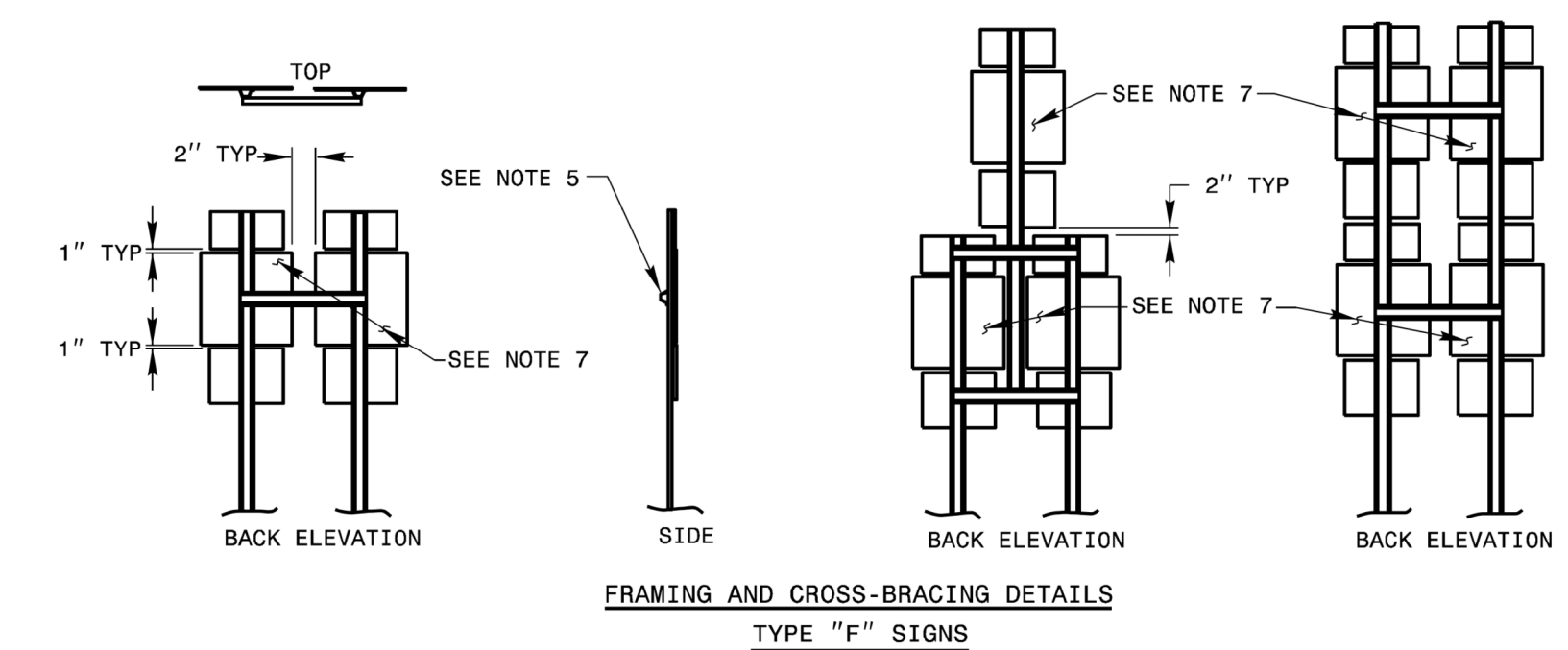
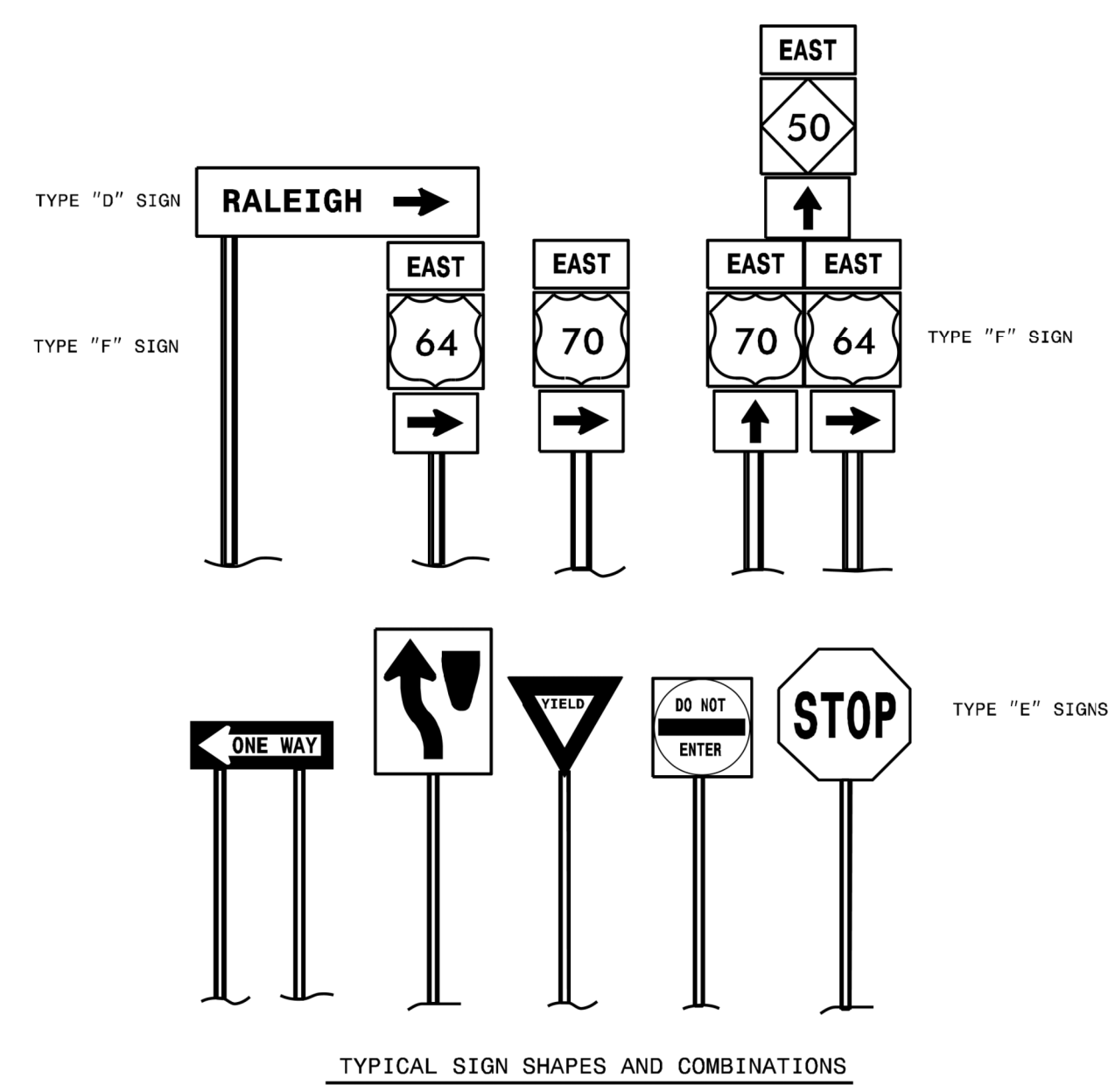
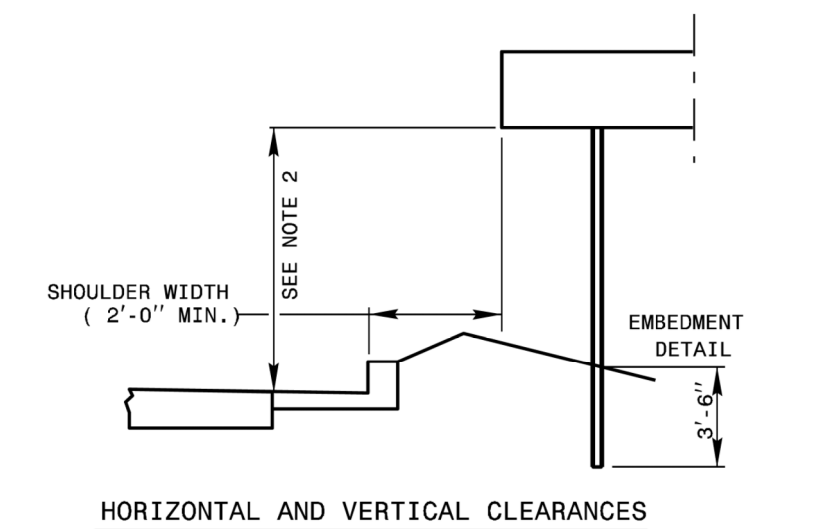
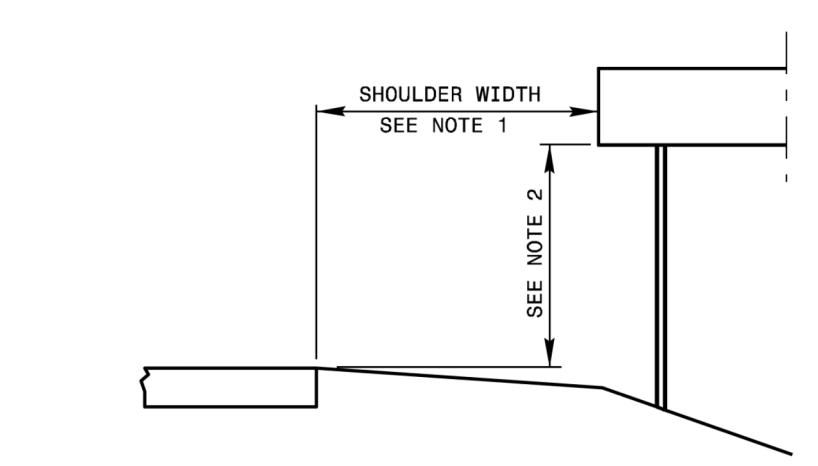

- NOTES:
1. ERECT TYPE "D", "E", AND "F" SIGNS ON FREEWAYS WITH THE NEAR EDGE OF THE SIGN 20 FT. FROM THE TRAVEL LANE. ERECT ALL OTHER "D", "E", AND "F" SIGNS WITH THE NEAR EDGE OF THE SIGN AT THE EDGE OF THE SHOULDER BREAK (6 FT. MINIMUM CLEARANCE, 12 FT. DESIRABLE, FROM THE EDGE OF TRAVEL LANE), OR AS DIMENSIONED ON PLAN SHEETS.
 2. ERECT TYPE "D", "E", AND "F" SIGNS WITH THE BOTTOM OF SIGN ASSEMBLY AT LEAST 7 FT. ABOVE THE EDGE OF THE TRAVEL LANE ON ROADS WITH 2 OR MORE LANES IN THE SAME DIRECTION AND AT LEAST 5 FT. ON OTHER ROUTES. THE VERTICAL CLEARANCE IS 7 FT. WHERE REQUIRED FOR PEDESTRIAN TRAFFIC AND/OR PARKED VEHICLES.
 3. THE VERTICAL DIMENSION BETWEEN MOUNTING HOLE CENTERS ON ALL TYPES "D", "E", AND "F" SIGNS IS 30" MAXIMUM. THE VERTICAL AND HORIZONTAL DIMENSIONS BETWEEN MOUNTING HOLES IS TO THE WHOLE INCH. EACH SIGN PANEL HAS A MINIMUM OF 2 BOLTS PER SUPPORT.
 4. ATTACH SIGN W/ 5/16" HEX HEAD BOLT, NYLON WASHER, SHIM, FLAT WASHER, LOCK WASHER, HEX NUT. NO BUCKLING OF THE SIGN WILL BE PERMITTED. SEE ASSEMBLY DETAIL SHEET# 2 OF 904.50.
 5. FURNISH AND INSTALL CROSS-BRACING AS SHOWN IN DETAIL. PAINT ENDS OF CROSS BRACES W/ APPROVED. ZINC PAINT
 6. INSTALL POST AND CROSS-BRACING WITH THE WIDE SIDE OF THE FLANGE TOWARD THE BACK OF SIGN(S) FOR COMBINATION TYPE "D" AND "F" SIGNS.
 7. THE SHIELD HEIGHTS IN THESE ASSEMBLIES CAN NOT BE LARGER THAN 24".
 8. IF SIGN ASSEMBLIES REQUIRE MORE THAN TWO U-CHANNEL SUPPORTS, THE SUPPORTS SHALL BE PLACED A MINIMUM OF 4 FT. BETWEEN POSTS. NO MORE THAN TWO POSTS SHALL FALL WITHIN 7 FT. PATH, OR THE SIGN ASSEMBLY MUST BE PLACED BEHIND BARRIER PROTECTION.

STATE OF NORTH CAROLINA
DEPT. OF TRANSPORTATION
DIVISION OF HIGHWAYS
RALEIGH, N.C.

6-21

ENGLISH DETAIL DRAWING FOR
MOUNTING OF
TYPE 'D', 'E', AND 'F' SIGNS
ON 'U' CHANNEL POSTS

SHEET 1 OF 2
904D50

REVISED SIGNING
ROADWAY STANDARD DRAWING

User:dstokes

TIP NO. U-6003	SHEET NO. SIGN-3
APPROVED: <i>Ron King</i>	
DATE: 9/13/2023	
SEAL	
	
DOCUMENT NOT CONSIDERED FINAL UNLESS ALL SIGNATURES COMPLETED	

401 QUANTITY REQ'D 5

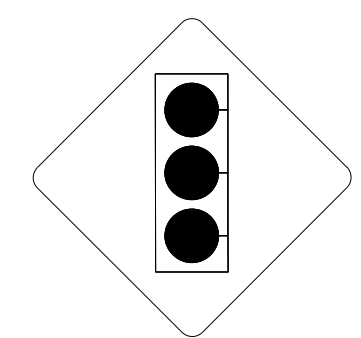

30" X 30"
W3-3

ONE "U" POST PER SIGN

406 QUANTITY REQ'D 2



24" X 8"
R3-17aP

MOUNT UNDER SIGN 405
IN 2 LOCATIONS

411 QUANTITY REQ'D 2



30" X 30"
W11-1

YELLOW/GREEN REFLECTIVE SHEETING

ONE "U" POST PER SIGN

501

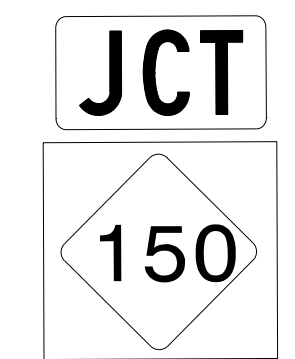

1-21" x 15"
1-24" x 24"

MOUNT ON ONE U-CHANNEL POST

402 QUANTITY REQ'D 5



24 X 30
R2-1

ONE "U" POST PER SIGN

407 QUANTITY REQ'D 2



24" X 8"
R3-17bP

MOUNT UNDER SIGN 405
IN 2 LOCATIONS

412 QUANTITY REQ'D 2



18" X 24"
W16-1P

YELLOW/GREEN REFLECTIVE SHEETING

MOUNT UNDER SIGN 411
IN 2 LOCATIONS

502

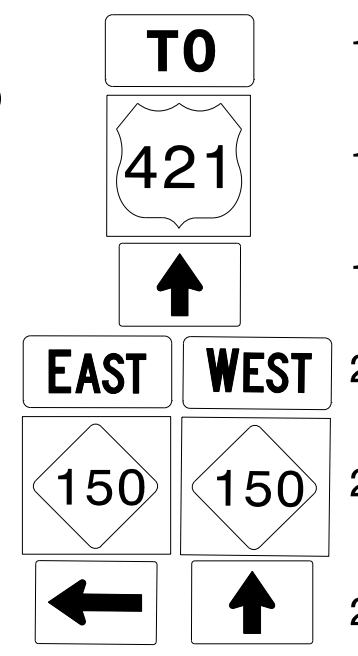

1-24" x 12"
1-30" x 24"
1-21" x 15"
2-24" x 12"
2-24" x 24"
2-21" x 15"

MOUNT ON TWO U-CHANNEL POSTS

403 QUANTITY REQ'D 2

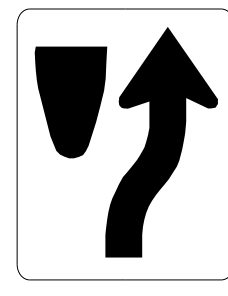

24" X 30"
R4-7

ONE "U" POST PER SIGN

408 QUANTITY REQ'D 2



36" X 36"
S1-1

YELLOW/GREEN REFLECTIVE SHEETING

ONE "U" POST

413 QUANTITY REQ'D 1



36" X 36"
W3-5

ONE "U" POST PER SIGN

404 QUANTITY REQ'D 2

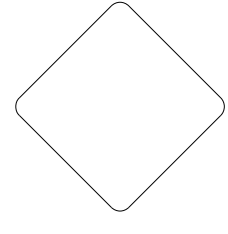

18" X 18"
OM1-3
(RED COLOR)

MOUNT UNDER SIGN 403
IN 2 LOCATIONS

409 QUANTITY REQ'D 2



24" X 12"
W16-9P

YELLOW/GREEN REFLECTIVE SHEETING

MOUNT UNDER SIGN 408
IN 1 LOCATION

405 QUANTITY REQ'D 4

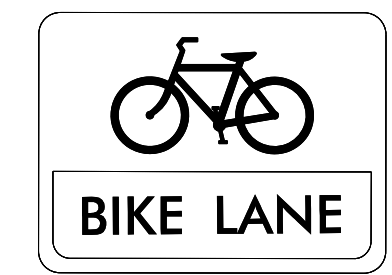

24" X 8"
R3-17

ONE "U" POST PER SIGN

410 QUANTITY REQ'D 1

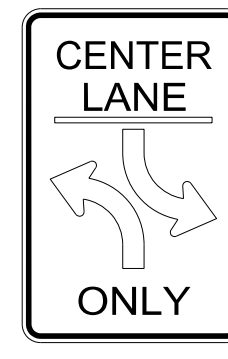

24" X 36"
R3-9B

ONE "U" POST



HDR Engineering, Inc. of the Carolinas
555 Fayetteville St, Suite 900 Raleigh, N.C. 27601
N.C.B.E.L.S. License Number: F-0116

TYPE "E" & "F" SIGNS

APPROVED: *Ron King*

DATE: 9/13/2023

SEAL



**DOCUMENT NOT CONSIDERED FINAL
UNLESS ALL SIGNATURES COMPLETED**

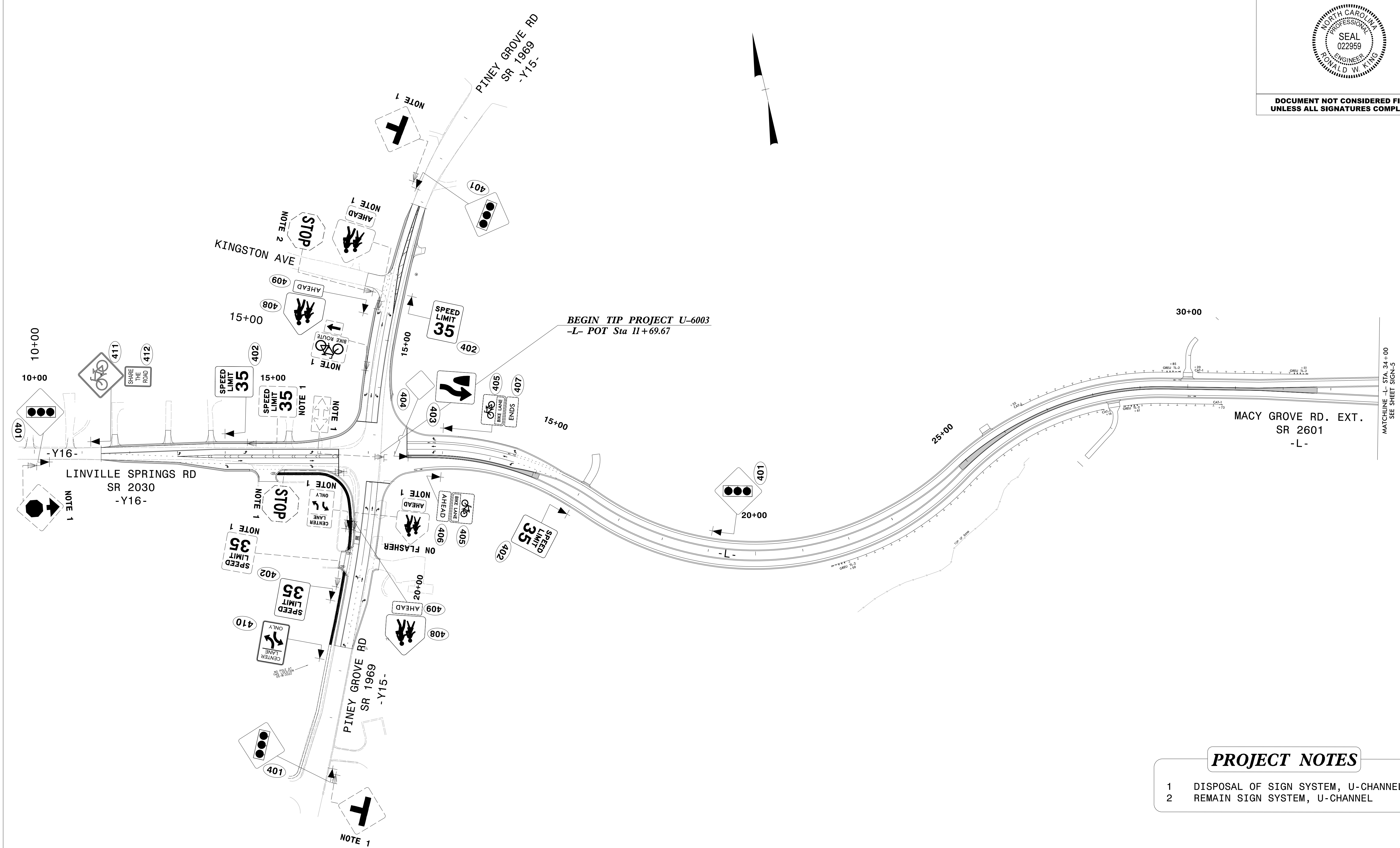

BEGIN TIP PROJECT U-6003
-L- POT Sta 11+69.67

MACY GROVE RD. EXT.
SR 2601
-L-

PROJECT NOTES

- 1 DISPOSAL OF SIGN SYSTEM, U-CHANNEL
- 2 REMAIN SIGN SYSTEM, U-CHANNEL

**EXISTING &
PROPOSED SIGNS**

07/24/23
G:\pwworking\ees01\cd0783184\U6003_sign_ct1.dgn
14:55:03

MATCHLINE -L- STA. 34+00
SEE SHEET SIGN-5

APPROVED: *Ron King*

DATE: 9/13/2023

SEAL



DOCUMENT NOT CONSIDERED FINAL
UNLESS ALL SIGNATURES COMPLETED

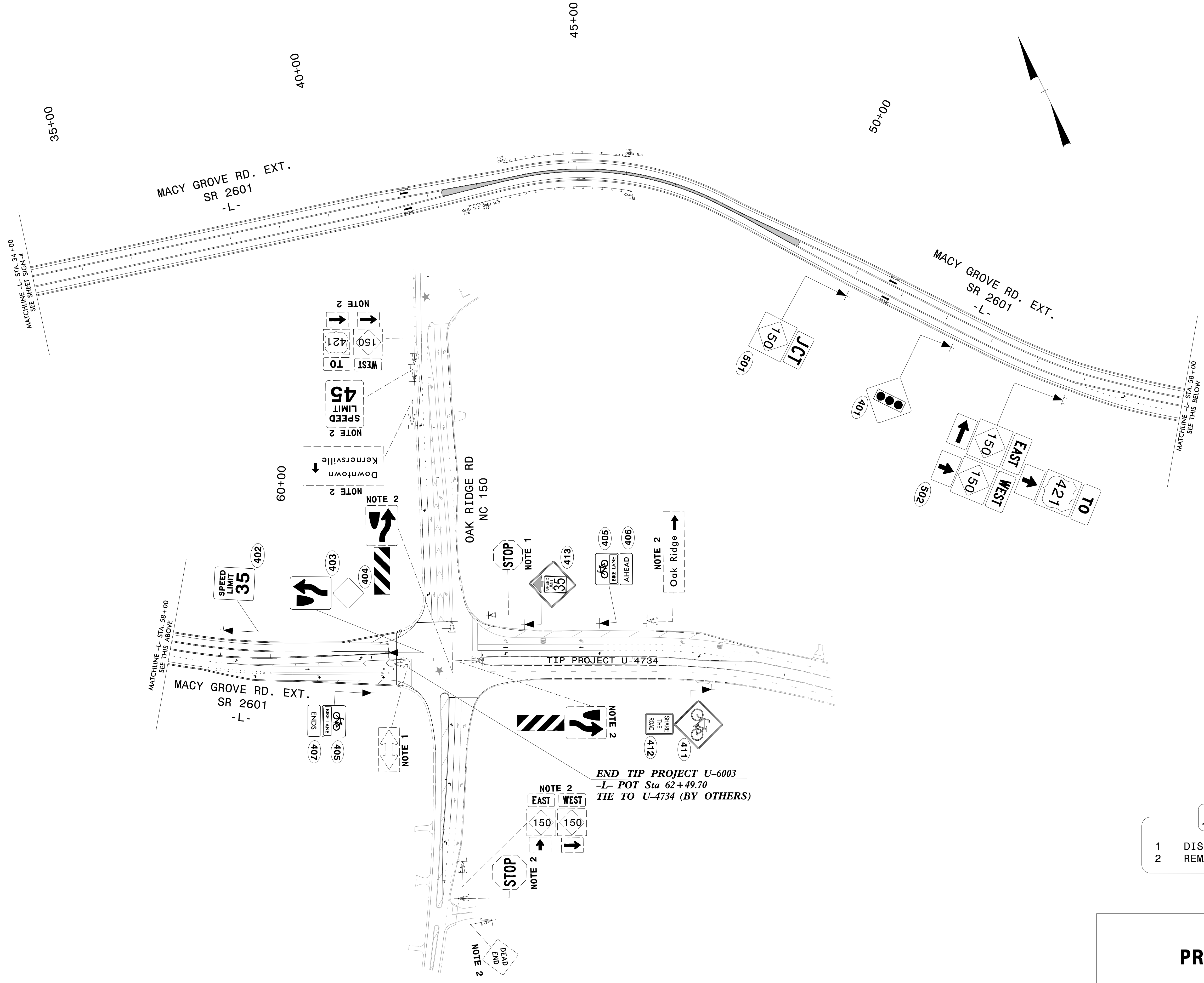

END TIP PROJECT U-6003
-L- POT Sta 62+49.70
TIE TO U-4734 (BY OTHERS)

- PROJECT NOTES**
- DISPOSAL OF SIGN SYSTEM, U-CHANNEL
 - REMAIN SIGN SYSTEM, U-CHANNEL

EXISTING & PROPOSED SIGNS

07/24/23
P:\pwr-king\east01\cd0783184\6003_sign_ctl_05.dgn
13:11:44