

09/08/99

TIP PROJECT: U-5824

STATE OF NORTH CAROLINA
DIVISION OF HIGHWAYS

T.I.P. NO.	SHEET NO.
U-5824	UO-1

NOTE:
ALL UTILITY WORK SHOWN ON THIS SHEET WILL BE DONE BY OTHERS.
NO PAYMENT WILL BE MADE TO THE CONTRACTOR FOR UTILITY WORK SHOWN ON THIS SHEET.

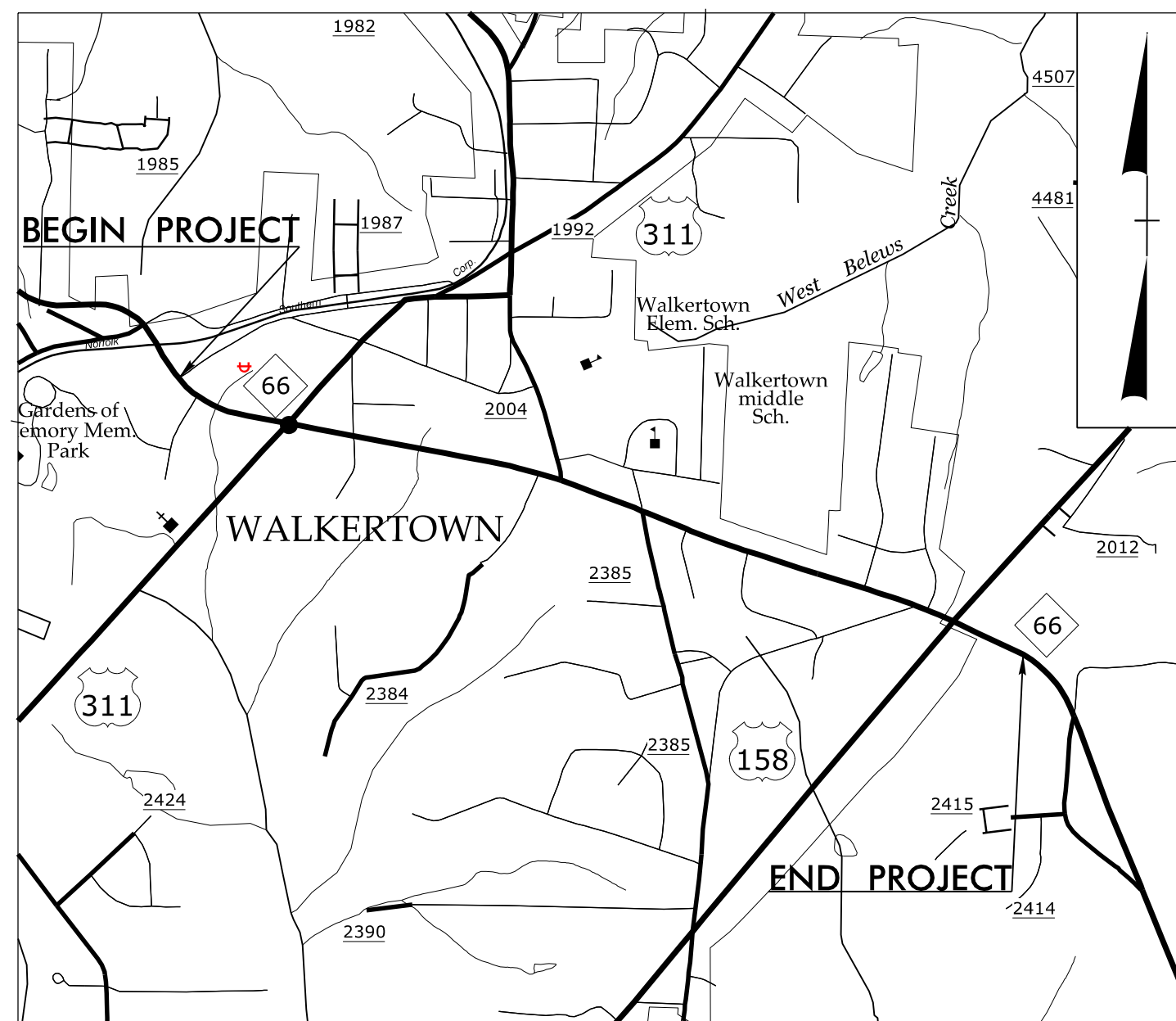

VICINITY MAP

NOTE: THIS PROJECT IS WITHIN MUNICIPAL BOUNDARIES OF THE CITY OF WALKERTOWN.

UTILITIES BY OTHERS PLANS
FORSYTH COUNTY

LOCATION: NC 66 (OLD HOLLOW ROAD) WIDENING
FROM HARLEY DRIVE TO US 158

TYPE OF WORK: GRADING, DRAINAGE, PAVING, AND RETAINING WALLS

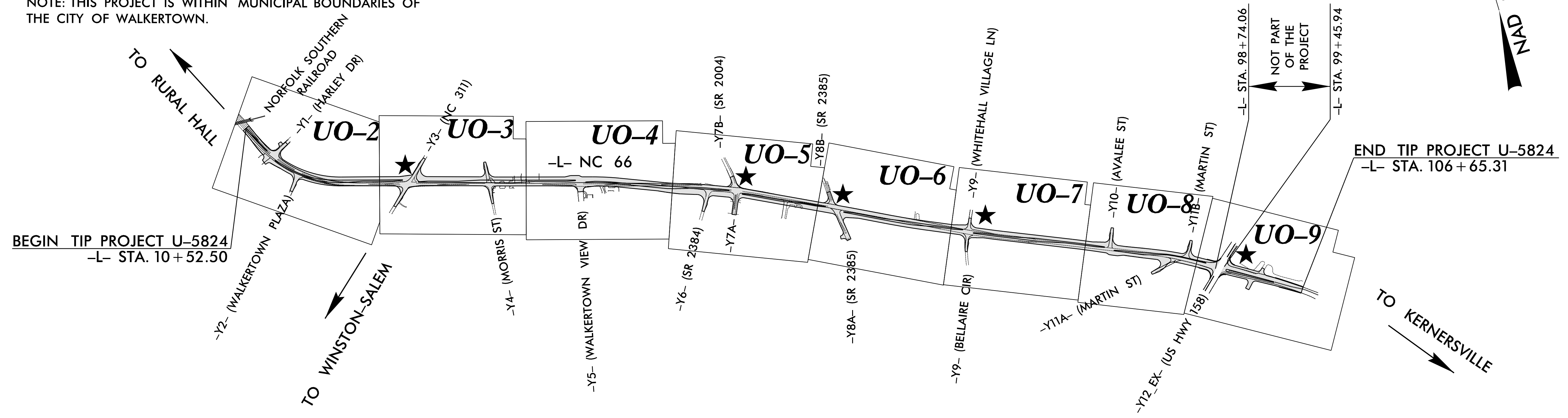

1107238
MAD

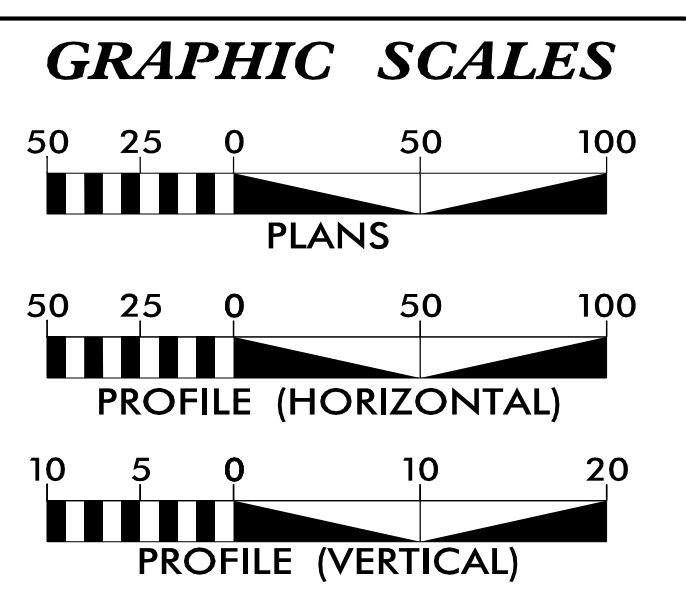

INDEX OF SHEETS

SHEET NO.:	DESCRIPTION:
UO-1	TITLE SHEET
UO-2 THRU UO-9	UBO PLAN SHEETS

UTILITY OWNERS WITH CONFLICTS

(A) POWER DISTRIBUTION - DUKE ENERGY
 (B) GAS DISTRIBUTION - PIEDMONT NATURAL GAS
 (C) COMMUNICATIONS - CENTURYLINK
 (D) COMMUNICATIONS/CABLE TV - SPECTRUM

PREPARED IN THE OFFICE OF:

TELICS
 1598 WESTBROOK PLAZA DR.
 SUITE 202
 WINSTON-SALEM, NC 27103
 (336) 705-8844

Cory Wood UTILITY PROJECT MANAGER
 Cory Wood PROJECT UTILITY COORDINATOR

**DIVISION OF HIGHWAYS
DIVISION 9**
 375 SILAS CREEK PARKWAY
 WINSTON SALEM, NC 27127

David Trantham DIVISION CONTACT #1
 Al Blanton DIVISION CONTACT #2
 Connie James DIVISION CONTACT #3
 DIVISION CONTACT #4

14-AUG-2023 2:42:29
C:\UBO_FILES\2017\U-5824\Utilities\Engineering\UBO\Proj\U5824_ut_1.sh_U001_psh.dgn
\$\$\$\$\$USERNAME\$\$\$\$\$

UTILITIES BY OTHERS

ALL PROPOSED UTILITY WORK SHOWN ON THIS SHEET WILL BE DONE BY OTHERS. NO PAYMENT WILL BE MADE TO THE CONTRACTOR FOR PROPOSED UTILITY WORK SHOWN ON THIS SHEET.

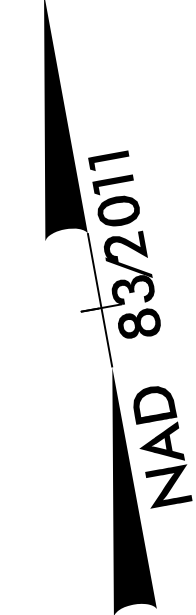

MATCHLINE -L- STA 37+00.00
(SEE SHEET UO-3)

MATCHLINE -L- STA 50+00.00
(SEE SHEET UO-5)

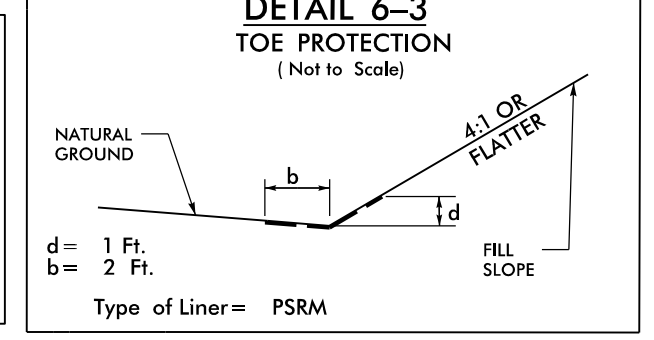
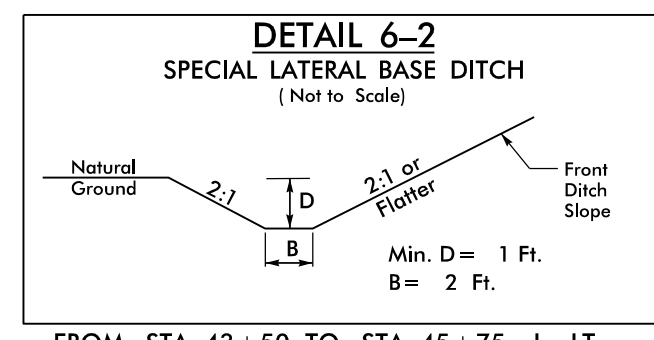
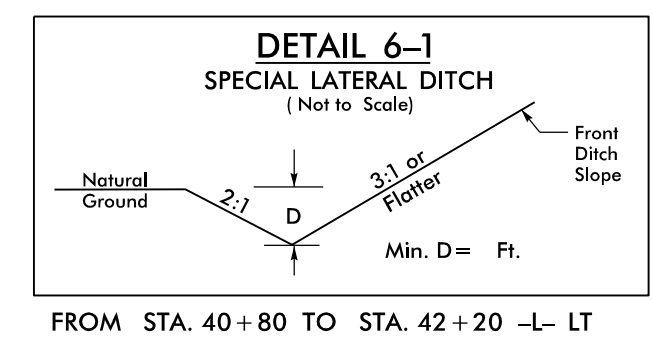
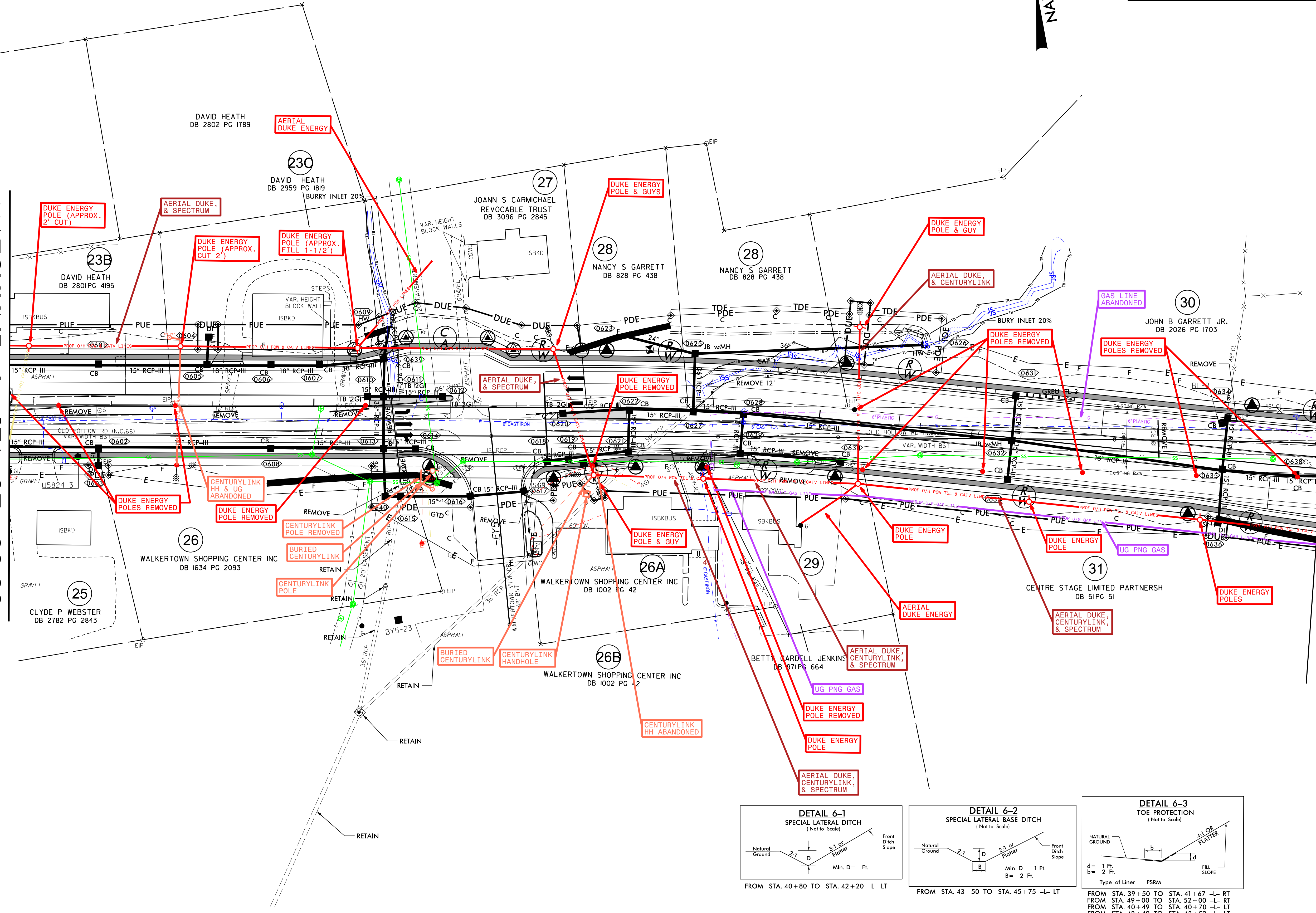

5/14/1999

U:\5824\AUG-2023\22122\perrying\UBO\A-Proj\U5824_ut_rdy6_UO04_psh.dgn

UTILITIES BY OTHERS

ALL PROPOSED UTILITY WORK SHOWN ON THIS SHEET WILL BE DONE BY OTHERS. NO PAYMENT WILL BE MADE TO THE CONTRACTOR FOR PROPOSED UTILITY WORK SHOWN ON THIS SHEET.

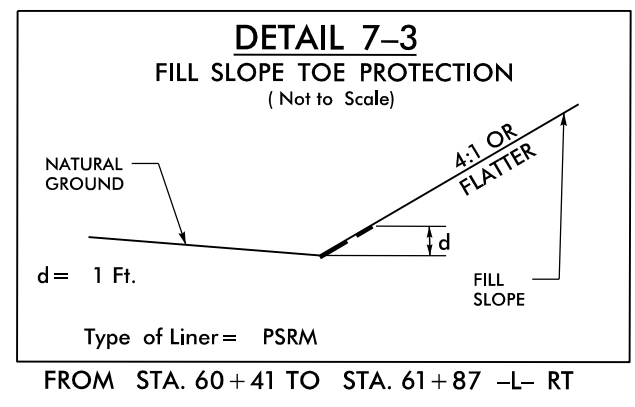
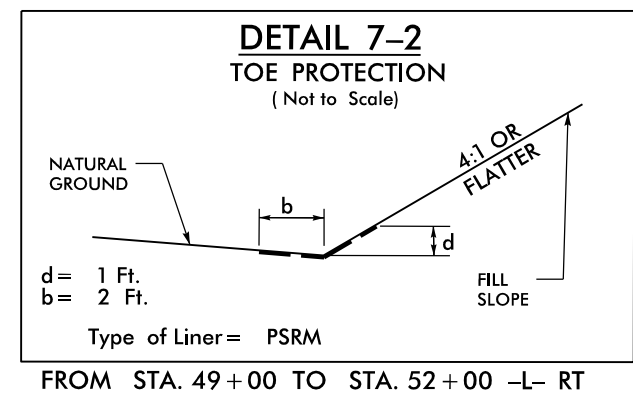
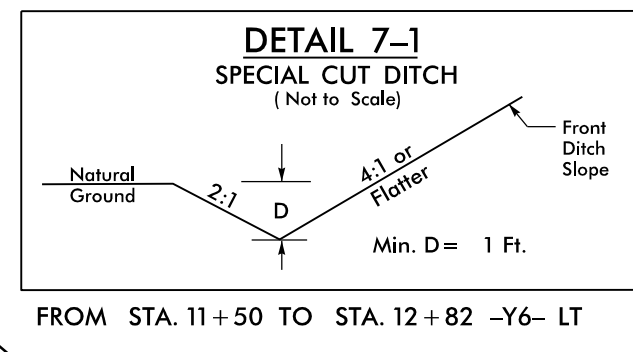

MATCHLINE -L- STA 50+00.00
(SEE SHEET UO-4)

MATCHLINE -L- STA 63+00.00
(SEE SHEET UO-6)

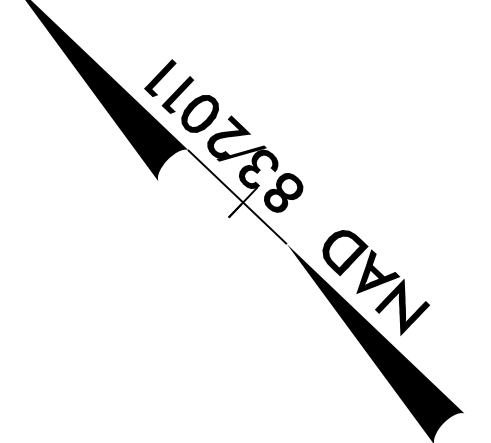
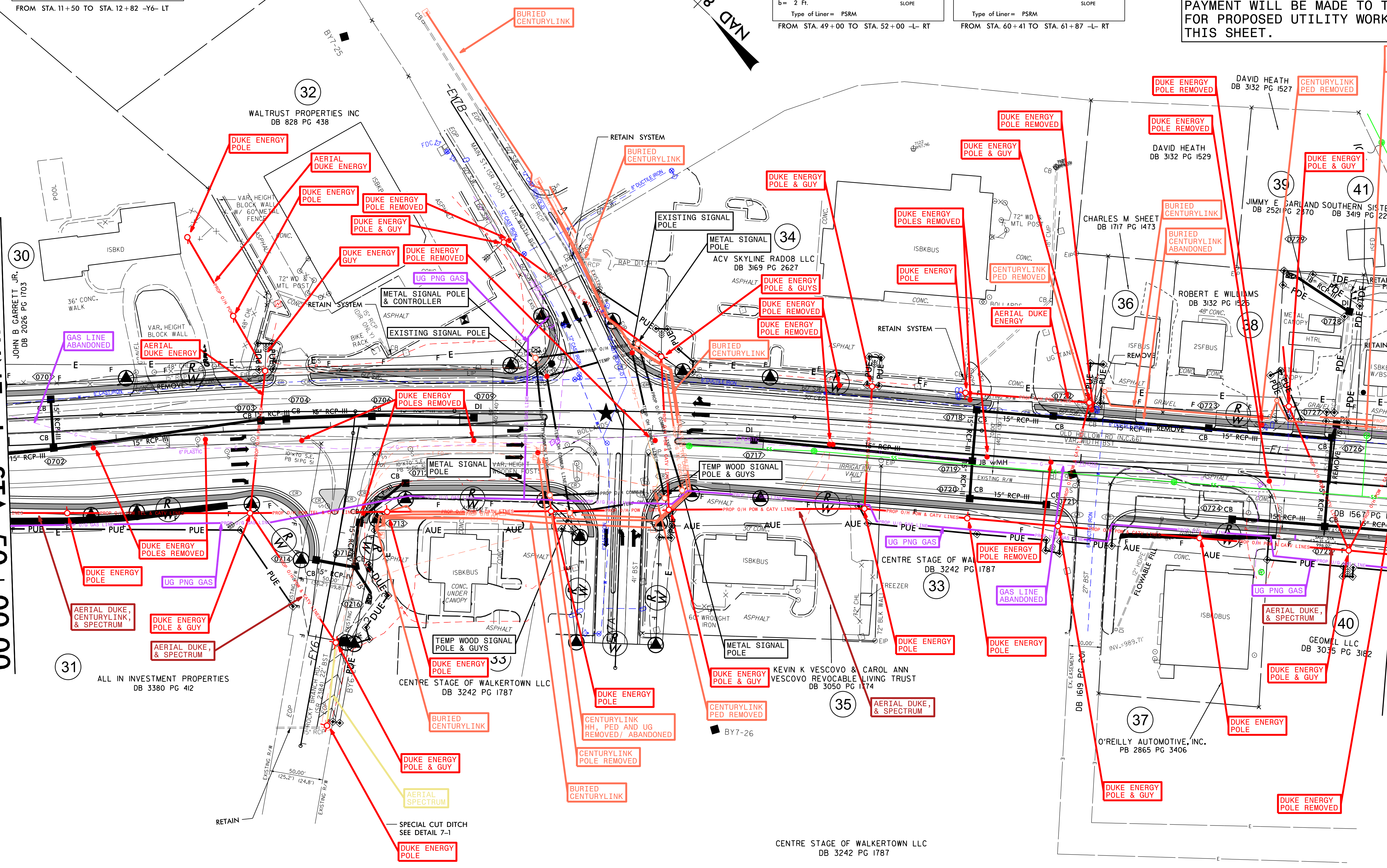

5/14/2023 22:25 U:\5824\Utilities\Engineering\UBO\Proj\U5824\ut_rdy7_U005_psh.dgn

