

T.I.P.: U-5824

CONTRACT:

STATE OF NORTH CAROLINA
DEPARTMENT OF TRANSPORTATION

SIGNING PLAN
FORSYTH COUNTY

LOCATION: NC 66 (OLD HOLLOW RD) FROM WEST OF HARLEY DR TO EAST OF US 158 (REIDSVILLE RD)

PROJECT REFERENCE NO. U-5824 SHEET NO. SIGN-1
APPROVED: [Signature] DATE: 9/28/2023
SEAL: [Professional Engineer Seal]
DOCUMENT NOT CONSIDERED FINAL UNLESS ALL SIGNATURES COMPLETED

SUMMARY OF QUANTITIES

Table with columns: ITEM NO., DESC. NO., SECT. NO., ITEM DESCRIPTION, QUANTITY, UNIT. Lists items like SUPPORTS, SIGN ERECTION, and DISPOSAL OF SIGN SYSTEM.

GENERAL NOTES

- SIGNS FURNISHED BY STATE (BUNN SIGN PLANT)
• CONFIRM IN WRITING AT LEAST 4 MONTHS IN ADVANCE, THE ACTUAL DATE THE DEPARTMENT FURNISHED SIGNS WILL BE REQUIRED.
• ALL TYPE 'D' SIGNS SHALL BE MOUNTED ON TWO U-CHANNEL POSTS UNLESS OTHERWISE INDICATED ON THE PLANS.
• IF REMOVAL OR RELOCATION OF SIGNS ON PRIVATE STREET (NON-STATE MAINTAINED) IS REQUIRED DUE TO CONSTRUCTION, THE CONTRACTOR SHALL INFORM THE ENGINEER. THE WORK WILL BE COMPLETED BY OTHERS.
• WHEN NOT STATIONED OR DIMENSIONED ON PLANS, ALL 'E' AND 'F' SIGNS SHALL BE FIELD LOCATED BY THE ENGINEER
• ALL EXISTING SIGNS ON "U" CHANNEL POST WITHIN THE PROJECT LIMITS SHALL BE REMOVED AND DISPOSED OF UNLESS OTHERWISE NOTED ON PLANS.
• WHEN EXISTING SIGNS ARE REMOVED AND INSTALLED ON NEW SUPPORTS, THE RE-ERECTION SHALL IMMEDIATELY FOLLOW THE REMOVAL.
• THE BACKGROUND FOR TYPE E & F SIGNS SHALL BE TYPE C REFLECTIVE SHEETING.
• SEE ROADWAY PLANS FOR GUARD/GUIDE RAIL DETAILS.

ROADWAY STANDARD DRAWING

THE FOLLOWING ROADWAY STANDARDS AS APPEAR IN "ROADWAY STANDARD DRAWINGS" - PROJECT SERVICES UNIT - N.C. DEPARTMENT OF TRANSPORTATION - RALEIGH, N.C., DATED JANUARY 2018 ARE APPLICABLE TO THIS PROJECT AND BY REFERENCE HEREBY ARE CONSIDERED A PART OF THESE PLANS:
STD. NO. TITLE
901.50 ARROWS AND SHIELDS
904.10 ORIENTATION OF GROUND MOUNTED SIGNS
904.50 MOUNTING OF TYPE 'D', 'E' AND 'F' SIGNS ON 'U' CHANNEL POSTS
910.30 SIGNING SIGNALIZED AND UNSIGNALIZED SUPERSTREET
910.50 SIGNING FOR SPEED REDUCTION ZONE

PROJECT NOTES

- 1 SIGN ERECTION, TYPE D, E, AND F
2 RELOCATE EXIST. ADOPT A HIGHWAY SIGN
3 RELOCATE EXIST. NEIGHBORHOOD SPEED LIMIT SIGN

INDEX

Table with columns: SHEET NO., DESCRIPTION. Lists sheets SIGN-1 through SIGN-5-9 and their descriptions.

Table with columns: PLAN SUBMITTED TO: NCDOT SIGNING AND DELINEATION UNIT, Name, Title. Lists Kelvin L. Jordan and Eric Ward.

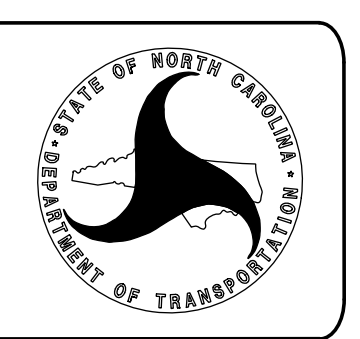

Table with columns: PLAN PREPARED BY: Name, Title. Lists Zhaolong (Gavin) Teng, Pe, Ptoe and Briana N. Phillips, Pe.

ACCELERATE ENGINEERING, PLLC
875 Walnut Street, Suite 316
Cary, NC 27511
Tel: 919.263.5678 Fax: 919.263.5687
NC License No. P-1442

TIP NO.	SHEET NO.
U-5824	DocuSigned by: SIGN - 2
APPROVED:	Matthew V. Springer
DATE:	6/23/2021
SEAL	

STATE OF NORTH CAROLINA
DEPT. OF TRANSPORTATION
DIVISION OF HIGHWAYS
RALEIGH, N.C.

6-21

ENGLISH DETAIL DRAWING FOR
MOUNTING OF
TYPE 'D', 'E', AND 'F' SIGNS
ON 'U' CHANNEL POSTS

SHEET 1 OF 2
904D50

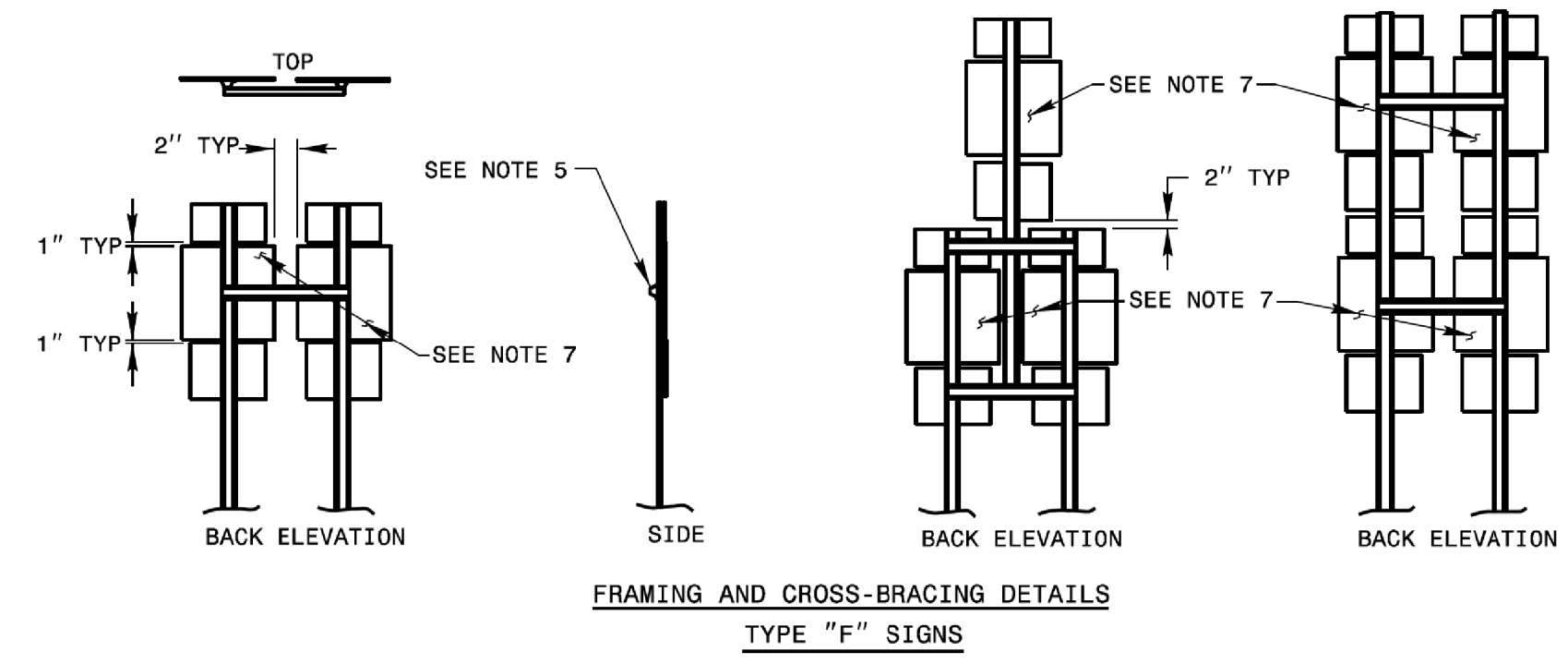
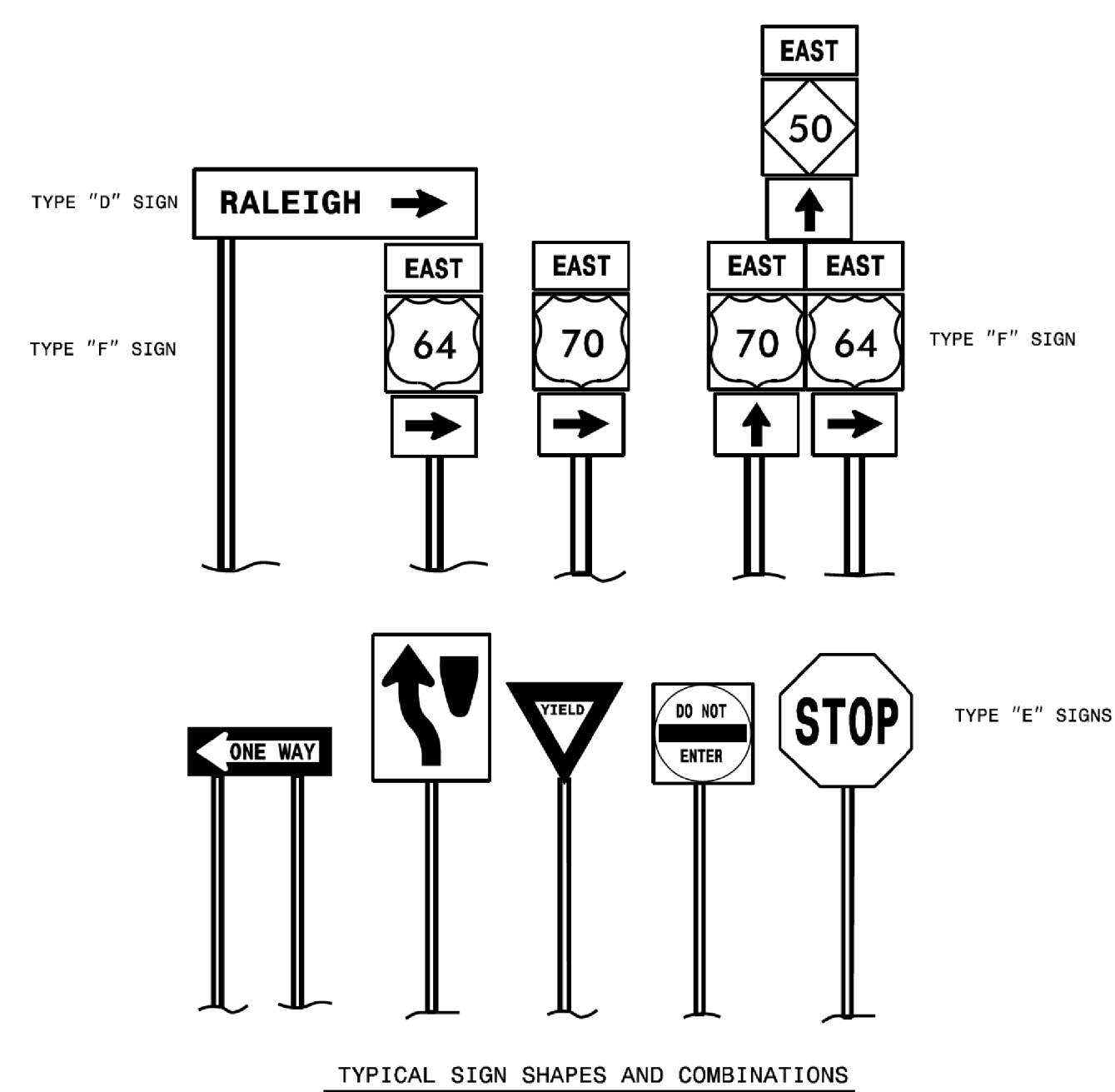
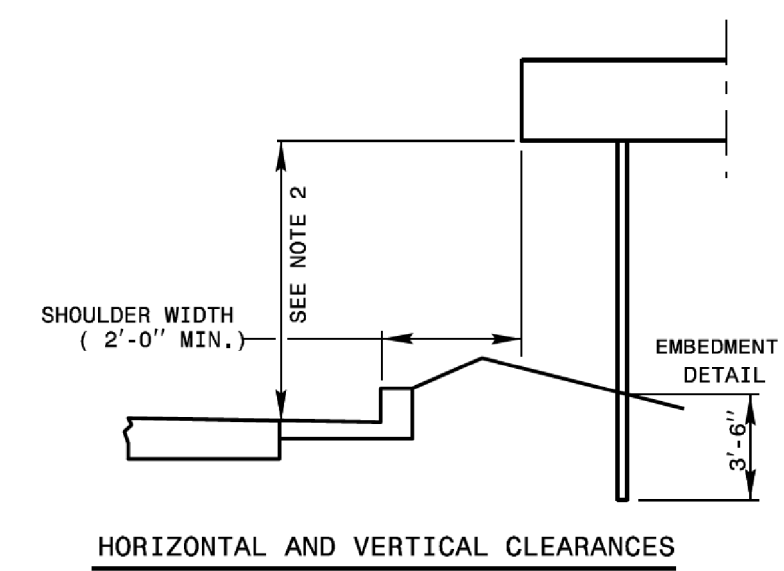
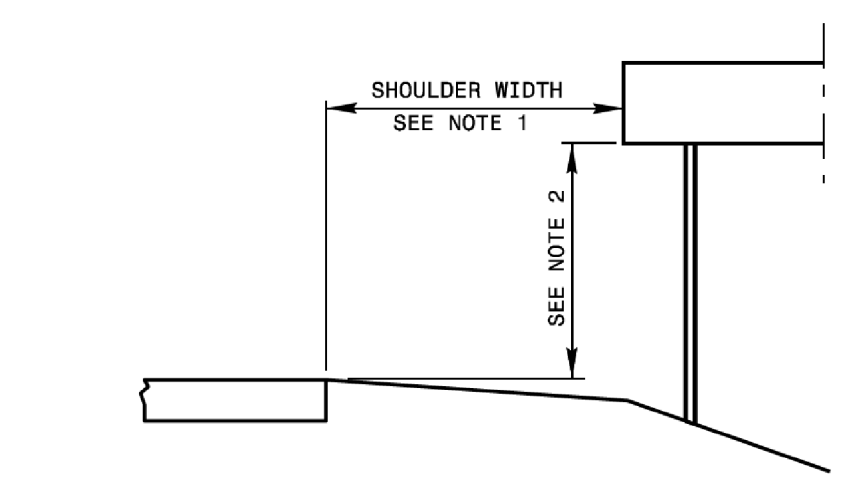

FRAMING AND CROSS-BRACING DETAILS
TYPE "F" SIGNS

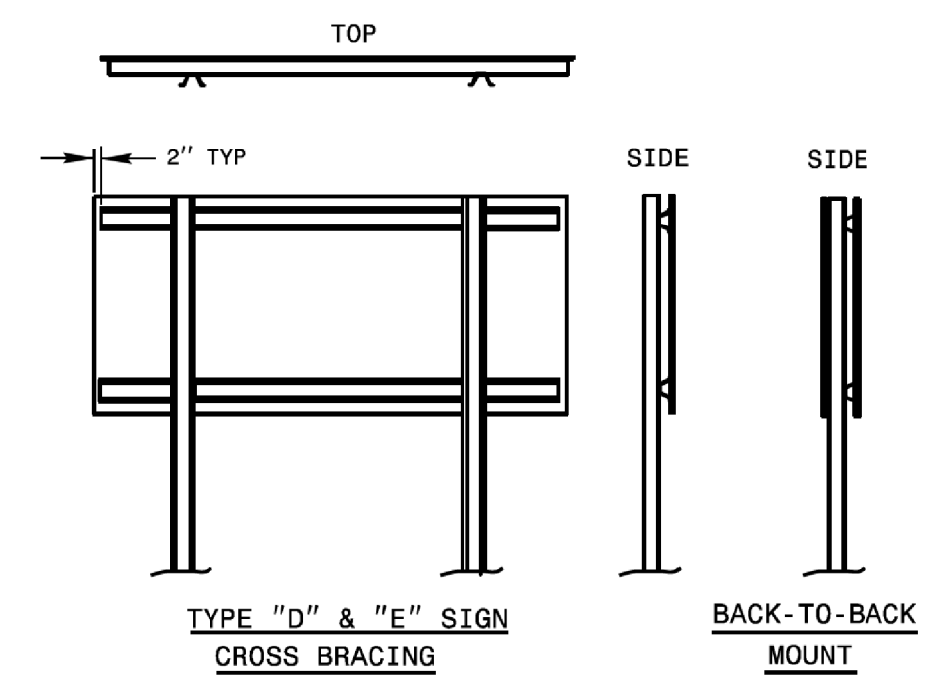

FRAMING AND CROSS BRACE DETAILS
FOR COMBINATION TYPE "D" & "E" SIGNS
WIDE SIDE OF CROSS BRACE GOES TO BACK OF SIGN

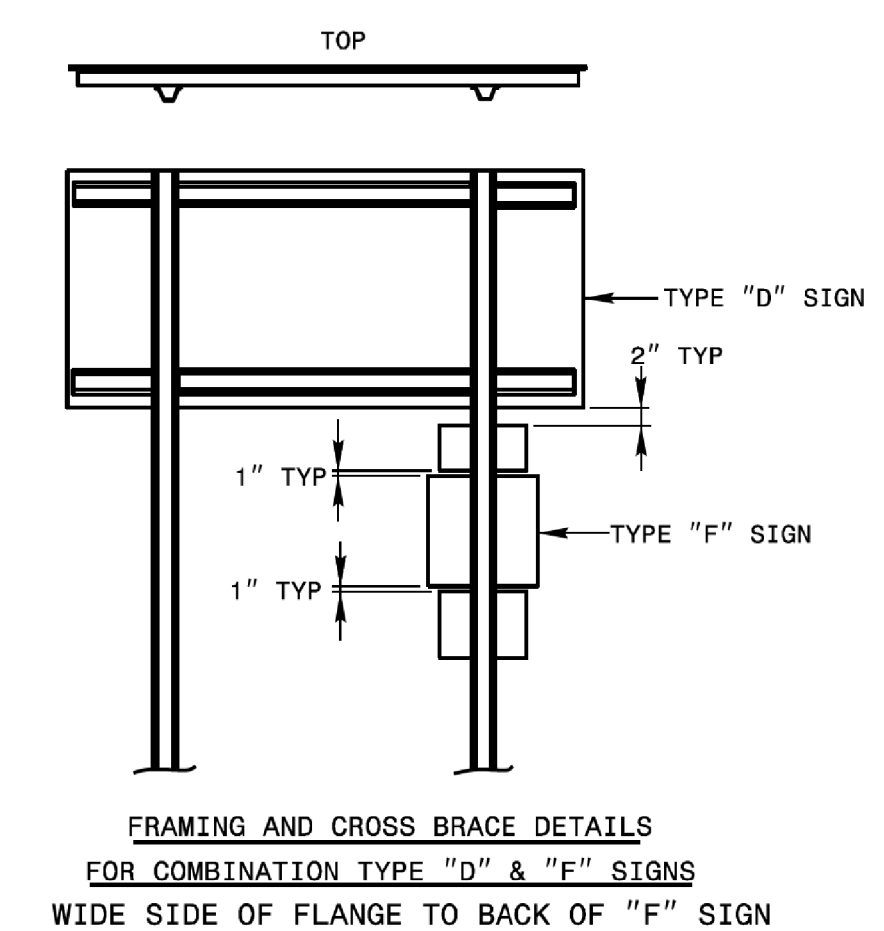

FRAMING AND CROSS BRACE DETAILS
FOR COMBINATION TYPE "D" & "F" SIGNS
WIDE SIDE OF FLANGE TO BACK OF "F" SIGN

- NOTES:
1. ERECT TYPE "D", "E", AND "F" SIGNS ON FREEWAYS WITH THE NEAR EDGE OF THE SIGN 20 FT. FROM THE TRAVEL LANE. ERECT ALL OTHER "D", "E", AND "F" SIGNS WITH THE NEAR EDGE OF THE SIGN AT THE EDGE OF THE SHOULDER BREAK (6 FT. MINIMUM CLEARANCE, 12 FT. DESIRABLE, FROM THE EDGE OF TRAVEL LANE), OR AS DIMENSIONED ON PLAN SHEETS.
 2. ERECT TYPE "D", "E", AND "F" SIGNS WITH THE BOTTOM OF SIGN ASSEMBLY AT LEAST 7 FT. ABOVE THE EDGE OF THE TRAVEL LANE ON ROADS WITH 2 OR MORE LANES IN THE SAME DIRECTION AND AT LEAST 5 FT. ON OTHER ROUTES. THE VERTICAL CLEARANCE IS 7 FT. WHERE REQUIRED FOR PEDESTRIAN TRAFFIC AND/OR PARKED VEHICLES.
 3. THE VERTICAL DIMENSION BETWEEN MOUNTING HOLE CENTERS ON ALL TYPES "D", "E", AND "F" SIGNS IS 30" MAXIMUM. THE VERTICAL AND HORIZONTAL DIMENSIONS BETWEEN MOUNTING HOLES IS TO THE WHOLE INCH. EACH SIGN PANEL HAS A MINIMUM OF 2 BOLTS PER SUPPORT.
 4. ATTACH SIGN W/ 5/16" HEX HEAD BOLT, NYLON WASHER, SHIM, FLAT WASHER, LOCK WASHER, HEX NUT. NO BUCKLING OF THE SIGN WILL BE PERMITTED. SEE ASSEMBLY DETAIL SHEET# 2 OF 904.50.
 5. FURNISH AND INSTALL CROSS-BRACING AS SHOWN IN DETAIL. PAINT ENDS OF CROSS BRACES W/ APPROVED. ZINC PAINT
 6. INSTALL POST AND CROSS-BRACING WITH THE WIDE SIDE OF THE FLANGE TOWARD THE BACK OF SIGN(S) FOR COMBINATION TYPE "D" AND "F" SIGNS.
 7. THE SHIELD HEIGHTS IN THESE ASSEMBLIES CAN NOT BE LARGER THAN 24".
 8. IF SIGN ASSEMBLIES REQUIRE MORE THAN TWO U-CHANNEL SUPPORTS, THE SUPPORTS SHALL BE PLACED A MINIMUM OF 4 FT. BETWEEN POSTS. NO MORE THAN TWO POSTS SHALL FALL WITHIN 7 FT. PATH, OR THE SIGN ASSEMBLY MUST BE PLACED BEHIND BARRIER PROTECTION.

STATE OF NORTH CAROLINA
DEPT. OF TRANSPORTATION
DIVISION OF HIGHWAYS
RALEIGH, N.C.

6-21

ENGLISH DETAIL DRAWING FOR
MOUNTING OF
TYPE 'D', 'E', AND 'F' SIGNS
ON 'U' CHANNEL POSTS

SHEET 1 OF 2
904D50

REVISED SIGNING
ROADWAY STANDARD DRAWING

6/18/2021 S:\S&DU\S\Standards and Drawings\Drawings\2018 Standard Dwg\Division 9 Final\0904.50_sgn_sht10_uchannel.post_6-21.dgn User:rdstokes

DocuSigned by:
Shaodong Teng
9/14/2023

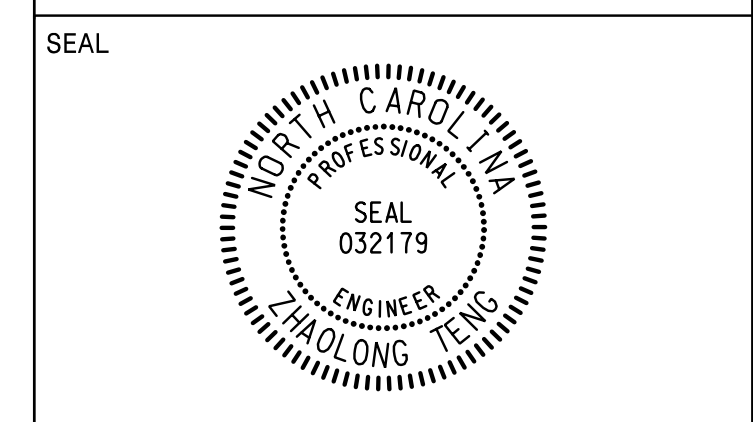

**DOCUMENT NOT CONSIDERED FINAL
UNLESS ALL SIGNATURES COMPLETED**

PREPARED IN THE OFFICE OF:
Accelerate Engineering, PLLC
875 Walnut Street, Suite 316
Cary, NC 27511
Tel: 919.263.5678 Fax: 919.263.5687
NC License No. P-1442

401 QUANTITY REQ'D 2

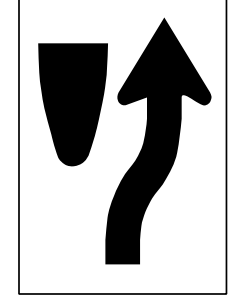

24 X 30
R4-7

ONE "U" POST PER SIGN

402 QUANTITY REQ'D 1



54 X 18
R6-1 (R)

TWO "U" POSTS PER SIGN

403 QUANTITY REQ'D 9



36 X 12
R6-1 (R)

TWO "U" POSTS PER SIGN

404 QUANTITY REQ'D 17

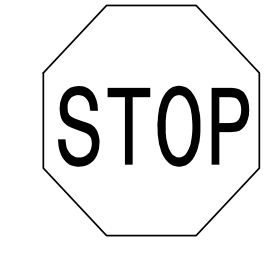

36 X 36
R1-1

ONE "U" POST PER SIGN
MOUNT BELOW SIGN NO. 403
IN 9 INSTALLATIONS

405 QUANTITY REQ'D 2

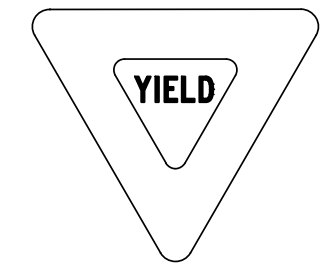

36 X 36 X 36
R1-2

ONE "U" POST PER SIGN

406 QUANTITY REQ'D 2



36 X 36
W11-2

YELLOW/GREEN REFLECTIVE SHEETING
ONE "U" POST PER SIGN

407 QUANTITY REQ'D 2

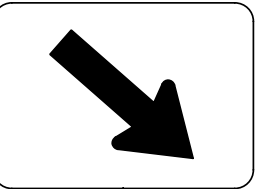

24 X 12
W16-7P(R)

YELLOW/GREEN REFLECTIVE SHEETING
MOUNT BELOW SIGN NO. 406
IN 2 INSTALLATIONS

408 QUANTITY REQ'D 7

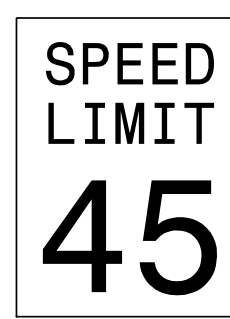

30 X 36
R2-1

ONE "U" POST PER SIGN

409 QUANTITY REQ'D 1

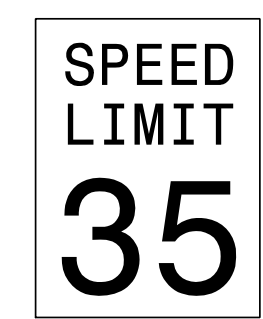

24 X 30
R2-1

ONE "U" POST PER SIGN

410 QUANTITY REQ'D 2



54 X 18
R6-1 (L)

TWO "U" POSTS PER SIGN

411 QUANTITY REQ'D 2

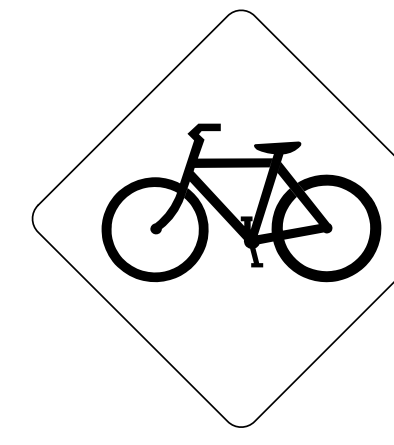

30 X 30
W11-1

ONE "U" POST PER SIGN

412 QUANTITY REQ'D 2



18 X 24
W16-1P

MOUNT BELOW SIGN 411
IN 2 INSTALLATIONS

413 QUANTITY REQ'D 2



36 X 36
R3-7

ONE "U" POST PER SIGN

414 QUANTITY REQ'D 8



24 X 18
R3-17

ONE "U" POST PER SIGN

415 QUANTITY REQ'D 2



24 X 8
R3-17aP

MOUNT BELOW SIGN 414
IN 2 INSTALLATIONS

416 QUANTITY REQ'D 2



24 X 8
R3-17bP

MOUNT BELOW SIGN 414
IN 2 INSTALLATIONS

417 QUANTITY REQ'D 1

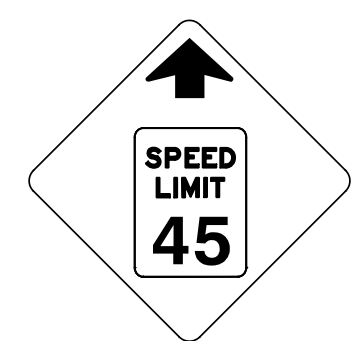

36 X 36
W3-5

ONE "U" POST PER SIGN

418 QUANTITY REQ'D 1

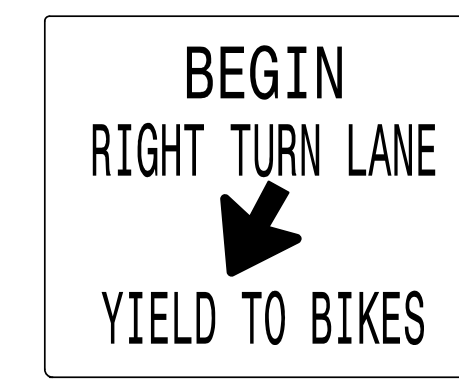

36 X 30
R4-4

ONE "U" POST PER SIGN

419 QUANTITY REQ'D 1

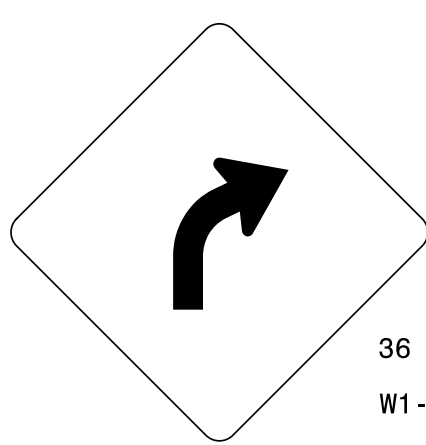

36 X 36
W1-2 (R)

ONE "U" POST PER SIGN

11/14/2023 10:58:11 AM

TYPE "E" SIGNS

<p>501 510</p> <p>ONE "U" POST</p>	<p>502</p> <p>TWO "U" POSTS</p>	<p>503</p> <p>TWO "U" POSTS</p>	<p>504</p> <p>TWO "U" POSTS</p>	<p>505</p> <p>TWO "U" POSTS</p>	<p>506</p> <p>ONE "U" POST</p>
------------------------------------	---------------------------------	---------------------------------	---------------------------------	---------------------------------	--------------------------------

<p>507</p> <p>TWO "U" POSTS</p>	<p>508</p> <p>TWO "U" POSTS</p>	<p>509</p> <p>ONE "U" POST</p>	<p>511 520 522</p> <p>ONE "U" POST</p>	<p>512 516 521</p> <p>ONE "U" POST</p>	<p>513 519</p> <p>ONE "U" POST</p>
---------------------------------	---------------------------------	--------------------------------	--	--	------------------------------------

<p>514</p> <p>ONE "U" POST</p>	<p>515</p> <p>TWO "U" POSTS</p>	<p>517</p> <p>TWO "U" POSTS</p>	<p>518</p> <p>TWO "U" POSTS</p>	<p>523</p> <p>ONE "U" POST</p>	
--------------------------------	---------------------------------	---------------------------------	---------------------------------	--------------------------------	--

PROJECT REFERENCE NO. U-5824	SHEET NO. SIGN-3A
APPROVED: <i>Shaolong Teng</i> DocuSigned by: 6B6BA0DE5257455.	
DATE: 9/14/2023	
SEAL 	
DOCUMENT NOT CONSIDERED FINAL UNLESS ALL SIGNATURES COMPLETED	
PREPARED IN THE OFFICE OF: Accelerate Engineering, PLLC 875 Walnut Street, Suite 316 Cary, NC 27511 Tel: 919.263.5678 Fax: 919.263.5687 NC License No. P-1442	

TYPE "F" SIGNS

5
6
7
8
9
10
11
12
13
14
15
16
17
18
19
20
21
22
23
24
25
26
27
28
29
30
31
32
33
34
35
36
37
38
39
40
41
42
43
44
45
46
47
48
49
50
51
52
53
54
55
56
57
58
59
60
61
62
63
64
65
66
67
68
69
70
71
72
73
74
75
76
77
78
79
80
81
82
83
84
85
86
87
88
89
90
91
92
93
94
95
96
97
98
99
100

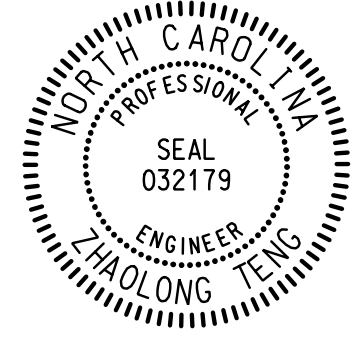
PROJECT REFERENCE NO. U-5824	SHEET NO. SIGN-4
APPROVED: <i>Shadong Teng</i> 9/14/2023	
DATE: 9/14/2023	
SEAL 	
DOCUMENT NOT CONSIDERED FINAL UNLESS ALL SIGNATURES COMPLETED	
<p>PREPARED IN THE OFFICE OF:</p> <p>Accelerate Engineering, PLLC 875 Walnut Street, Suite 316 Cary, NC 27511 Tel: 919.263.5678 Fax: 919.263.5687 NC License No. P-1442</p>	

SIGN NUMBER: 301 TYPE: D QUANTITY: 1 SIGN WIDTH: 6'-6" HEIGHT: 2'-6" TOTAL AREA: 16.3 Sq.Ft. BORDER TYPE: FLUSH RECESS: 0" WIDTH: 0.75" RADI: 2.25" NO. Z BARS: LENGTH:	BACKG COLOR: Green COPY COLOR: White SYMBOL X Y WID HT AR_Type D 6.5 19.3 6 9 AR_Type D 63.2 4.7 6 9 MAT'L: 0.125" (3.2 mm) ALUMINUM	DESIGN BY: G. Teng PROJECT ID: U-5824 CHECKED BY: B. Phillips LOCATION: -L- STA. 23+30± Jan 26, 2023 DIV: 9
--	---	--

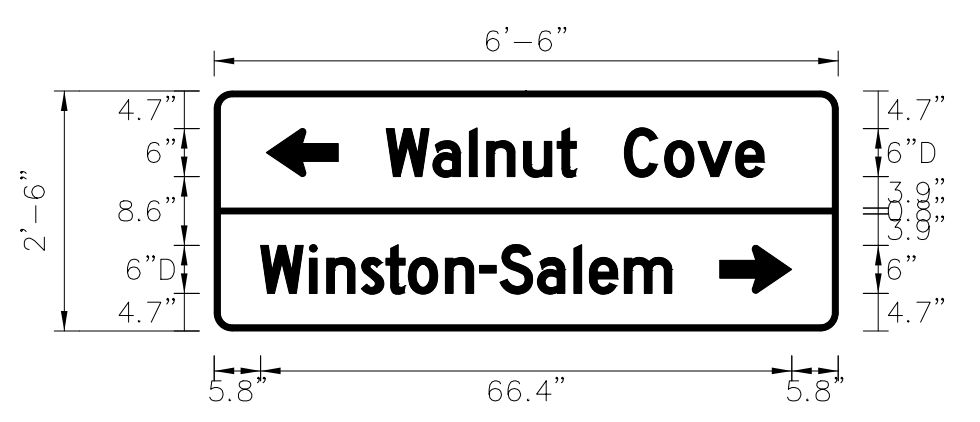

USE NOTES: 1,2
1. Legend and border(except those that are colored black) shall be direct applied Grade C sheeting.
2. Background shall be Grade C reflective sheeting.

Spacing Factor is 1 unless specified otherwise

LETTER POSITIONS

Letter spacings are to start of next letter															Series/Size
															Text Length
21.5	5.8	4.6	2.2	4.6	4.2	2.4	6	5	4.1	4.7	3.5	9.3			D 2000
															47.2
5.8	6.1	2.2	4.3	3.1	2.8	4.6	4.3	2.6	4.7	4.6	1.9	4.4	5.9	20.8	D 2000
															51.4

FILENAME: U-5824_Sgn_Guidesign NORTH CAROLINA D.O.T. SIGN DETAIL

SIGN NUMBER: 302 TYPE: D QUANTITY: 1 SIGN WIDTH: 6'-6" HEIGHT: 2'-6" TOTAL AREA: 16.3 Sq.Ft. BORDER TYPE: FLUSH RECESS: 0" WIDTH: 0.75" RADI: 2.25" NO. Z BARS: LENGTH:	BACKG COLOR: Green COPY COLOR: White SYMBOL X Y WID HT AR_Type D 5.8 19.3 6 9 AR_Type D 61.1 4.7 6 9 MAT'L: 0.125" (3.2 mm) ALUMINUM	DESIGN BY: G. Teng PROJECT ID: U-5824 CHECKED BY: B. Phillips LOCATION: -L- STA. 30+10± Jan 26, 2023 DIV: 9
--	---	--

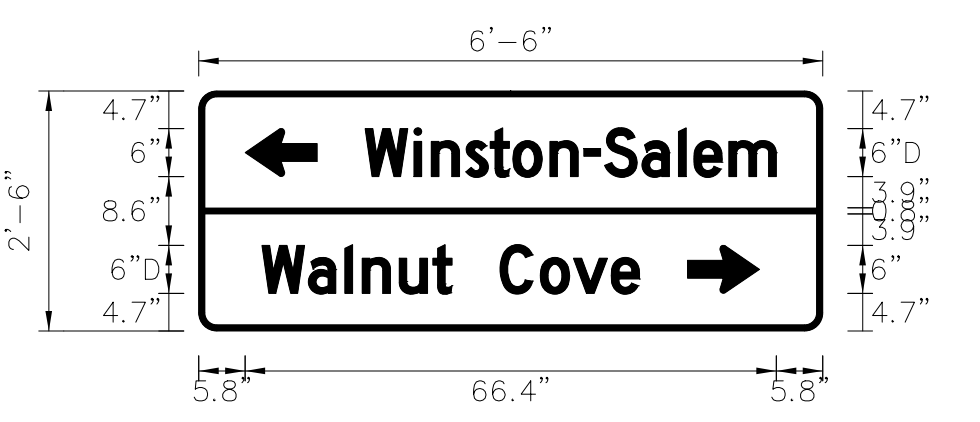

USE NOTES: 1,2
1. Legend and border(except those that are colored black) shall be direct applied Grade C sheeting.
2. Background shall be Grade C reflective sheeting.

Spacing Factor is 1 unless specified otherwise

LETTER POSITIONS

Letter spacings are to start of next letter															Series/Size
															Text Length
20.8	6.1	2.2	4.3	3.1	2.8	4.6	4.3	2.6	4.7	4.6	1.9	4.4	5.9	5.8	D 2000
															51.4
7.9	5.8	4.6	2.2	4.6	4.2	2.4	6	5	4.1	4.7	3.5	22.9			D 2000
															47.2

FILENAME: U-5824_Sgn_Guidesign NORTH CAROLINA D.O.T. SIGN DETAIL

SIGN NUMBER: 303 TYPE: D QUANTITY: 1 SIGN WIDTH: 5'-6" HEIGHT: 2'-6" TOTAL AREA: 13.8 Sq.Ft. BORDER TYPE: FLUSH RECESS: 0" WIDTH: 0.75" RADI: 2.25" NO. Z BARS: LENGTH:	BACKG COLOR: Green COPY COLOR: White SYMBOL X Y WID HT AR_Type D 6 19.3 6 9 AR_Type D 49.8 4.7 6 9 MAT'L: 0.125" (3.2 mm) ALUMINUM	DESIGN BY: G. Teng PROJECT ID: U-5824 CHECKED BY: B. Phillips LOCATION: -Y3- STA. 11+00± Jan 26, 2023 DIV: 9
--	---	---

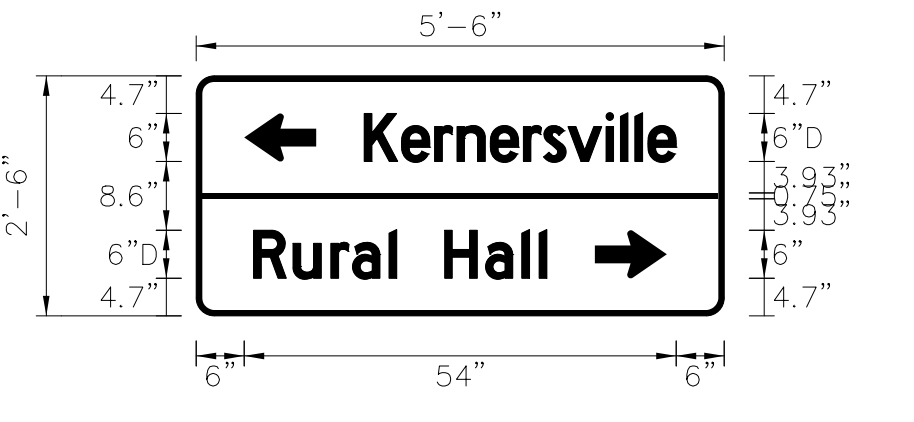

USE NOTES: 1,2
1. Legend and border(except those that are colored black) shall be direct applied Grade C sheeting.
2. Background shall be Grade C reflective sheeting.

Spacing Factor is 1 unless specified otherwise

LETTER POSITIONS

Letter spacings are to start of next letter															Series/Size
															Text Length
21	4.7	4.1	2.8	4.2	4.1	2.5	3	4.8	1.8	1.8	1.6	3.5	6		D 2000
															39
7.2	4.9	4.7	2.7	4.6	1	6	5.1	4.6	2.2	1	22.2				D 2000
															36.7

FILENAME: U-5824_Sgn_Guidesign NORTH CAROLINA D.O.T. SIGN DETAIL

SIGN NUMBER: 304 TYPE: D QUANTITY: 1 SIGN WIDTH: 6'-6" HEIGHT: 2'-6" TOTAL AREA: 16.3 Sq.Ft. BORDER TYPE: FLUSH RECESS: 0" WIDTH: 0.75" RADI: 2.25" NO. Z BARS: LENGTH:	BACKG COLOR: Green COPY COLOR: White SYMBOL X Y WID HT AR_Type D 5.8 19.3 6 9 AR_Type D 63.2 4.7 6 9 MAT'L: 0.125" (3.2 mm) ALUMINUM	DESIGN BY: G. Teng PROJECT ID: U-5824 CHECKED BY: B. Phillips LOCATION: -L- STA. 95+90± Jan 26, 2023 DIV: 9
--	---	--

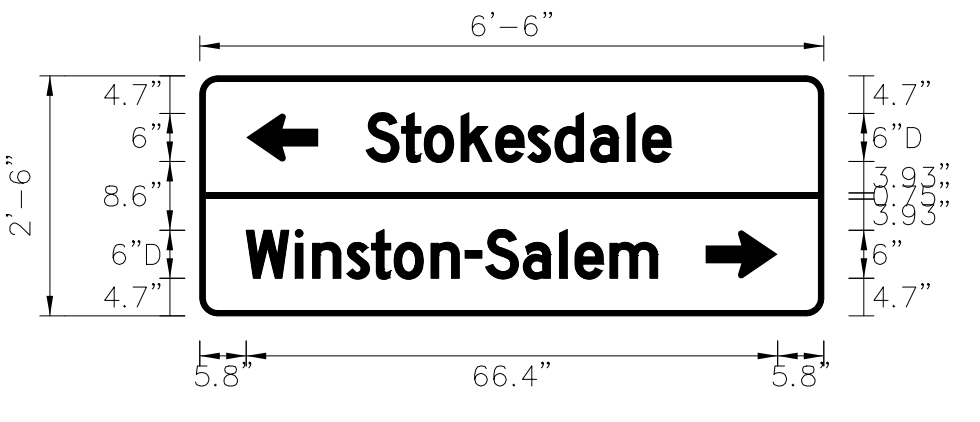

USE NOTES: 1,2
1. Legend and border(except those that are colored black) shall be direct applied Grade C sheeting.
2. Background shall be Grade C reflective sheeting.

Spacing Factor is 1 unless specified otherwise

LETTER POSITIONS

Letter spacings are to start of next letter															Series/Size
															Text Length
20.8	4.4	2.8	4.6	4.3	4	3.4	4.5	4.6	1.9	3.5	19.1				D 2000
															38.1
5.8	6.1	2.2	4.3	3.1	2.8	4.6	4.3	2.6	4.7	4.6	1.9	4.4	5.9	20.8	D 2000
															51.4

FILENAME: U-5824_Sgn_Guidesign NORTH CAROLINA D.O.T. SIGN DETAIL

SIGN NUMBER: 305 TYPE: D QUANTITY: 1 SIGN WIDTH: 6'-6" HEIGHT: 2'-6" TOTAL AREA: 16.3 Sq.Ft. BORDER TYPE: FLUSH RECESS: 0" WIDTH: 0.75" RADII: 2.25" NO. Z BARS: LENGTH:	BACKG COLOR: Green COPY COLOR: White <table border="1" style="width: 100%; border-collapse: collapse;"> <thead> <tr> <th>SYMBOL</th> <th>X</th> <th>Y</th> <th>WID</th> <th>HT</th> </tr> </thead> <tbody> <tr> <td>AR_Type D</td> <td>5.8</td> <td>19.3</td> <td>6</td> <td>9</td> </tr> <tr> <td>AR_Type D</td> <td>63.2</td> <td>4.7</td> <td>6</td> <td>9</td> </tr> </tbody> </table> MAT'L: 0.125" (3.2 mm) ALUMINUM	SYMBOL	X	Y	WID	HT	AR_Type D	5.8	19.3	6	9	AR_Type D	63.2	4.7	6	9	DESIGN BY: G. Teng PROJECT ID: U-5824 CHECKED BY: B. Phillips LOCATION: -L- STA. 102+05± Jan 26, 2023 DIV: 9
SYMBOL	X	Y	WID	HT													
AR_Type D	5.8	19.3	6	9													
AR_Type D	63.2	4.7	6	9													

Spacing Factor is 1 unless specified otherwise

LETTER POSITIONS

Letter spacings are to start of next letter														Series/Size	Text Length	
	W	i	n	s	t	o	n	-	S	a	i	e	m		D 2000	
20.8	6.1	2.2	4.3	3.1	2.8	4.6	4.3	2.6	4.7	4.6	1.9	4.4	5.9	5.8		51.4
	S	t	o	k	e	s	d	o	i	e		D 2000				
20	4.4	2.8	4.6	4.3	4	3.4	4.5	4.6	1.9	3.5	19.9		38.1			

NORTH CAROLINA D.O.T. SIGN DETAIL

SIGN NUMR: RNC3-26 TYPE: F Ground QUANTITY: 2 SIGN WIDTH: 1'-9" HEIGHT: 1'-9" TOTAL AREA: 3.1 Sq.Ft. MAT'L: 0.093" ALUMINUM BORDER TYPE: RECESSED RECESS: 0.38" WIDTH: 0.63" RADII: 1.5" NO. Z BARS: LENGTH:	BACKG. COLOR: White COPY COLOR: Black <table border="1" style="width: 100%; border-collapse: collapse;"> <thead> <tr> <th>SYMBOL</th> <th>X</th> <th>Y</th> <th>WID</th> <th>HT</th> </tr> </thead> <tbody> <tr> <td>u arrow</td> <td>3.7</td> <td>3.8</td> <td>12.7</td> <td>13.9</td> </tr> </tbody> </table>	SYMBOL	X	Y	WID	HT	u arrow	3.7	3.8	12.7	13.9	DESIGN BY: G. Teng PROJECT ID: U-5824 CHK BY: [Signature] DIV: 9 STD #: [Symbol] DATE: JAN 26, 2023 N. C. DEPARTMENT OF TRANSPORTATION DIVISION OF HIGHWAYS TRANSPORTATION MOBILITY & SAFETY SURVEY & DESIGN UNIT
SYMBOL	X	Y	WID	HT								
u arrow	3.7	3.8	12.7	13.9								

Spacing Factor is 1 unless specified otherwise

Arrow Details

ARROW DIMENSIONS (INCHES)	F	G	H	M	N	P	Q	R
	2.625	2.625	8.659	5.25	3	5.25	0.375	0.5

Spacing Factor is 1 unless specified otherwise

PROJECT REFERENCE NO. U-5824	SHEET NO. SIGN-4A
APPROVED: [Signature] DocuSigned by: Chadong Teng 688BA0E527455...	
DATE: 9/14/2023	
DOCUMENT NOT CONSIDERED FINAL UNLESS ALL SIGNATURES COMPLETED	
PREPARED IN THE OFFICE OF: Accelerate Engineering, PLLC 875 Walnut Street, Suite 316 Cary, NC 27511 Tel: 919.263.5678 Fax: 919.263.5687 NC License No. P-1442	

PROJECT REFERENCE NO. U-5824	SHEET NO. SIGN-6
APPROVED: <i>Shaolong Teng</i> <small>6868ADDE5257455</small>	
DATE: 9/14/2023	
SEAL 	
DOCUMENT NOT CONSIDERED FINAL UNLESS ALL SIGNATURES COMPLETED	
PREPARED IN THE OFFICE OF: Accelerate Engineering, PLLC 875 Walnut Street, Suite 316 Cary, NC 27511 Tel: 919.263.5678 Fax: 919.263.5687 NC License No. P-1442	

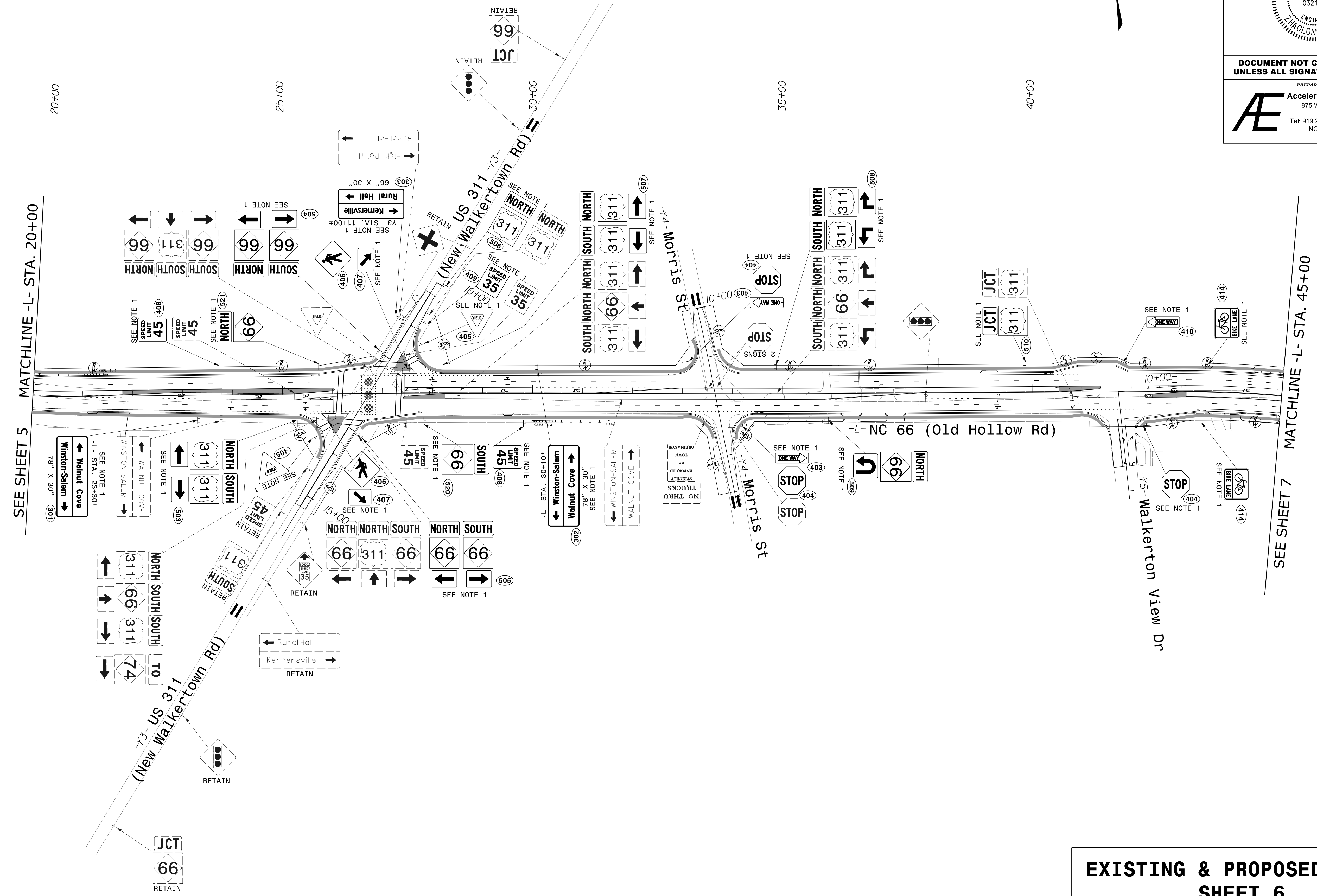

SEE SHEET 5 MATCHLINE -L- STA. 20+00

SEE SHEET 7 MATCHLINE -L- STA. 45+00

**EXISTING & PROPOSED SIGNS
SHEET 6**

\$\$\$
CITY OF WALKERTOWN
PLANNING DEPARTMENT
100 WALKERTOWN VIEW DRIVE
WALKERTOWN, NC 27587
919-263-5678
www.walkertownnc.gov

PROJECT REFERENCE NO. U-5824	SHEET NO. SIGN-9
APPROVED: <i>Chadlong Teng</i> 688BA0DE527455.	
DATE: 9/14/2023	
SEAL 	
DOCUMENT NOT CONSIDERED FINAL UNLESS ALL SIGNATURES COMPLETED	
PREPARED IN THE OFFICE OF: Accelerate Engineering, PLLC 875 Walnut Street, Suite 316 Cary, NC 27511 Tel: 919.263.5678 Fax: 919.263.5687 NC License No. P-1442	

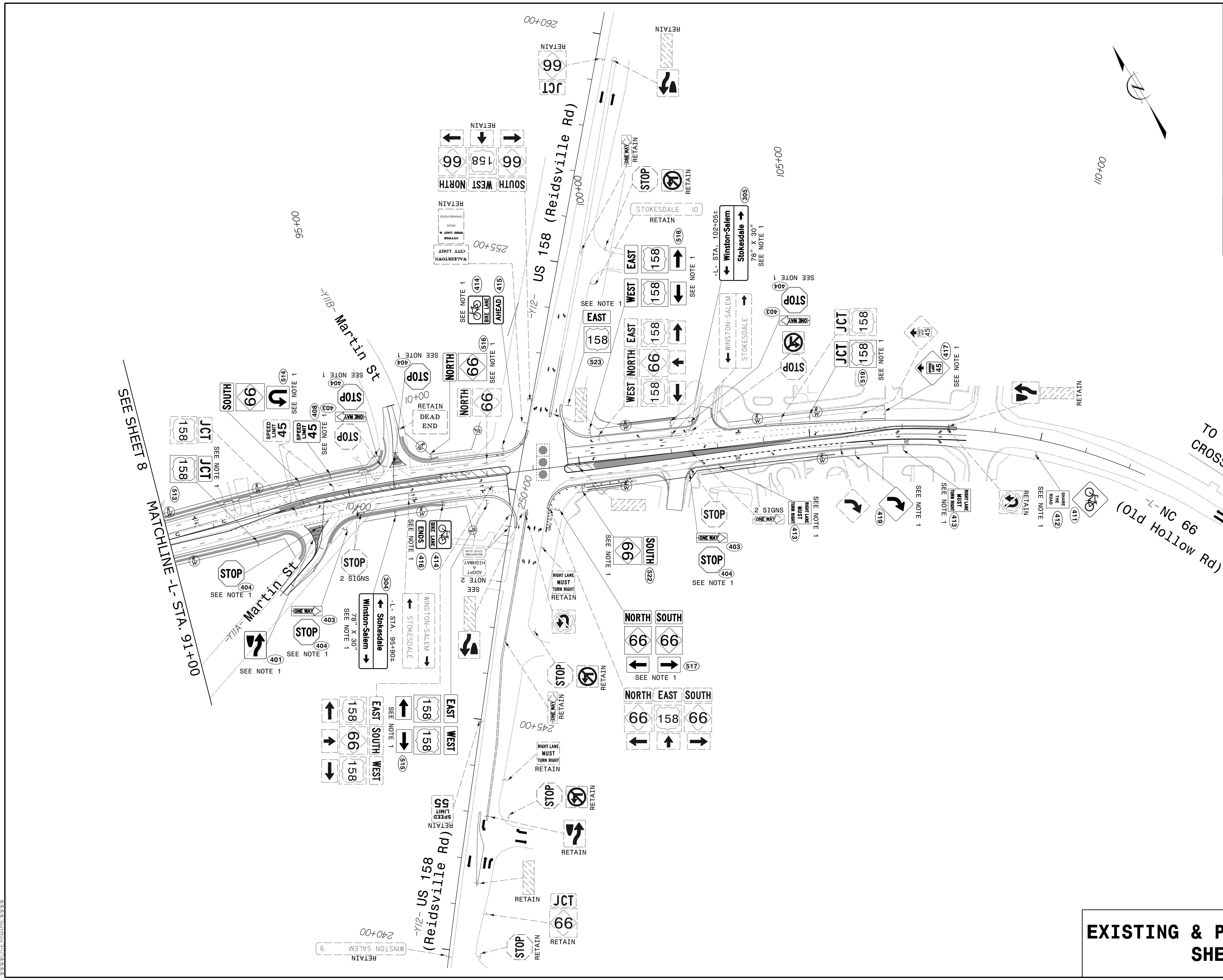

**EXISTING & PROPOSED SIGNS
SHEET 9**

\$\$\$
 1
 2
 3
 4
 5
 6
 7
 8
 9
 10
 11
 12
 13
 14
 15
 16
 17
 18
 19
 20
 21
 22
 23
 24
 25
 26
 27
 28
 29
 30
 31
 32
 33
 34
 35
 36
 37
 38
 39
 40
 41
 42
 43
 44
 45
 46
 47
 48
 49
 50
 51
 52
 53
 54
 55
 56
 57
 58
 59
 60
 61
 62
 63
 64
 65
 66
 67
 68
 69
 70
 71
 72
 73
 74
 75
 76
 77
 78
 79
 80
 81
 82
 83
 84
 85
 86
 87
 88
 89
 90
 91
 92
 93
 94
 95
 96
 97
 98
 99
 100
 \$\$\$