

09\_08/2019

See Sheet 1A For Index of Sheets  
See Sheet 1B For Conventional Symbols

STATE OF NORTH CAROLINA  
DIVISION OF HIGHWAYS

**FORSYTH COUNTY**

**LOCATION: NC 66 (OLD HOLLOW ROAD) WIDENING  
FROM HARLEY DRIVE TO US 158 IN WALKERTOWN  
TYPE OF WORK: GRADING, DRAINAGE, PAVING, SIGNALS, AND RETAINING WALLS**

STATE	STATE PROJECT REFERENCE NO.	SHEET NO.	TOTAL SHEETS
N.C.	U-5824	1	
STATE PROJ. NO.	F.A. PROJ. NO.	DESCRIPTION	
44395.1.1		PE	
44395.2.1		ROW	
44395.2.2		UTILITY	
44395.3.1		CONSTRUCTION	

**TIP PROJECT: U-5824**

**CONTRACT: C204879**

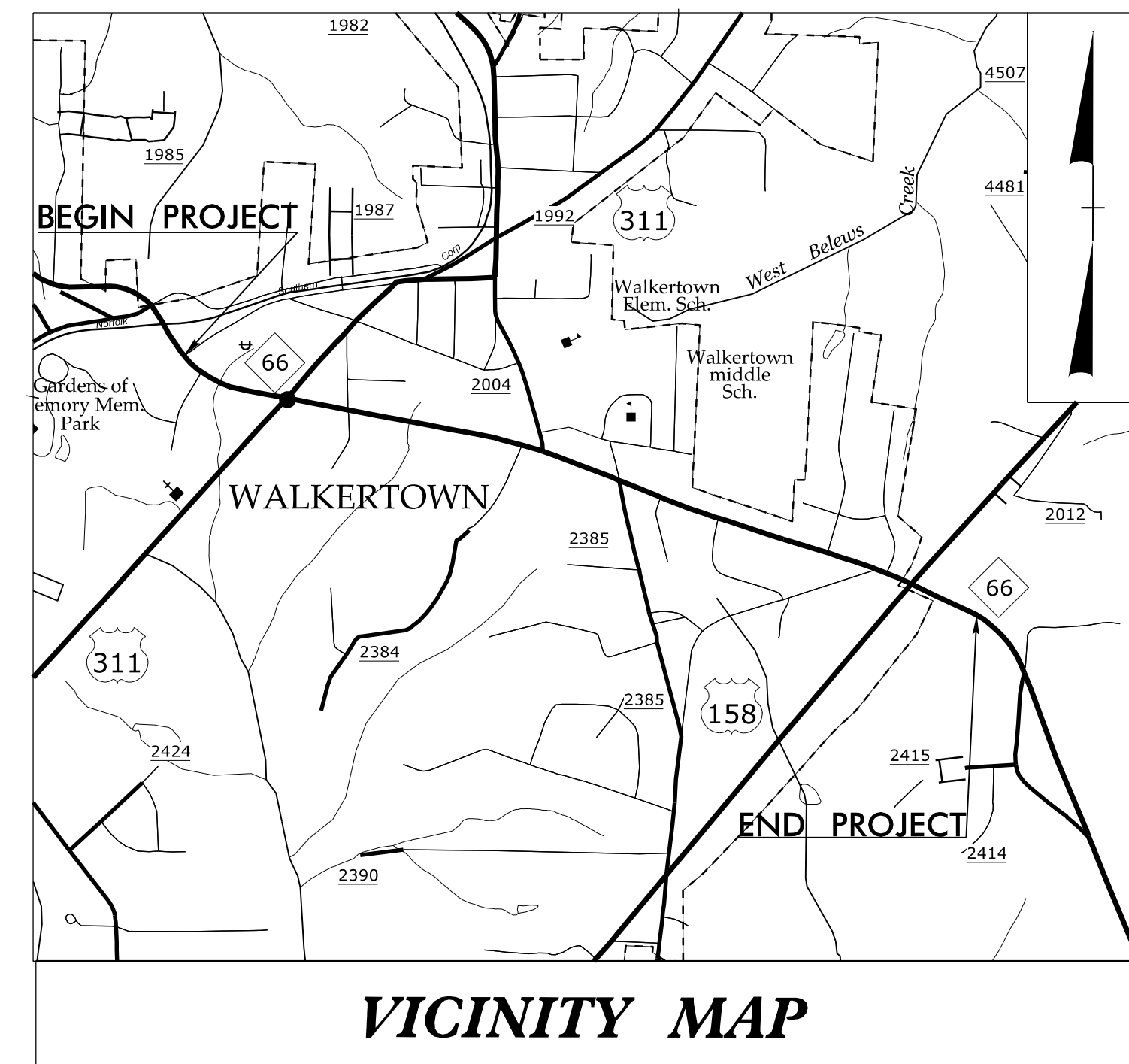

**VICINITY MAP**

SEE TMP PLANS FOR TEMPORARY OFFSITE DETOUR LOCATIONS.

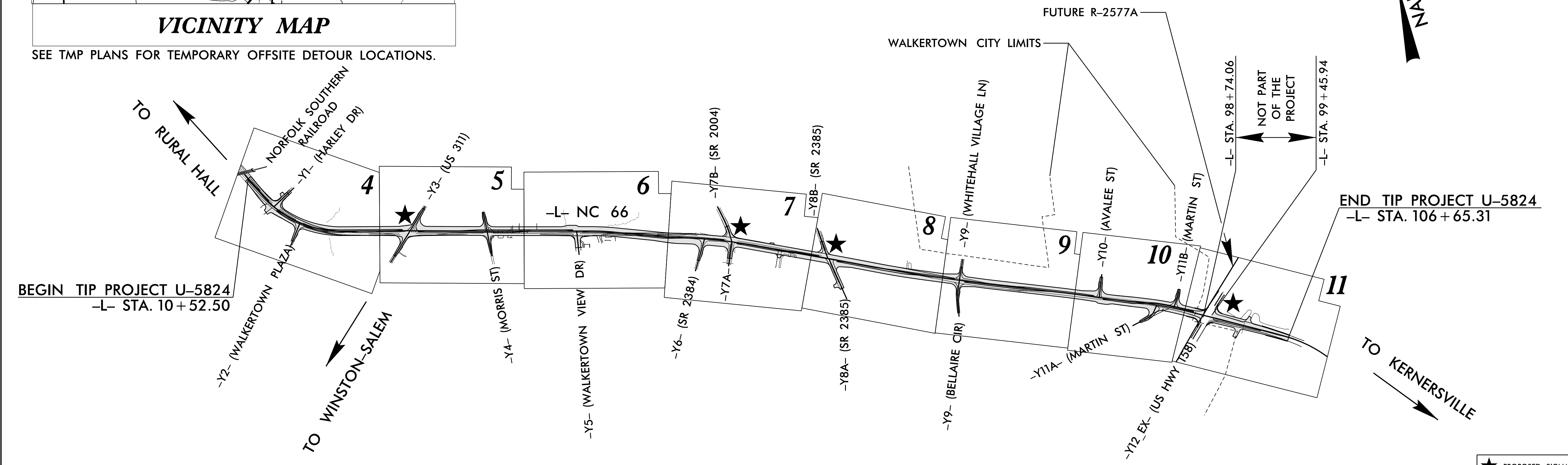

BEGIN TIP PROJECT U-5824  
-L- STA. 10 + 52.50

END TIP PROJECT U-5824  
-L- STA. 106 + 65.31

THIS PROJECT HAS PARTIAL CONTROL OF ACCESS WITH FULL CONTROL OF ACCESS AT POINTS AS SHOWN ON THE PLANS.

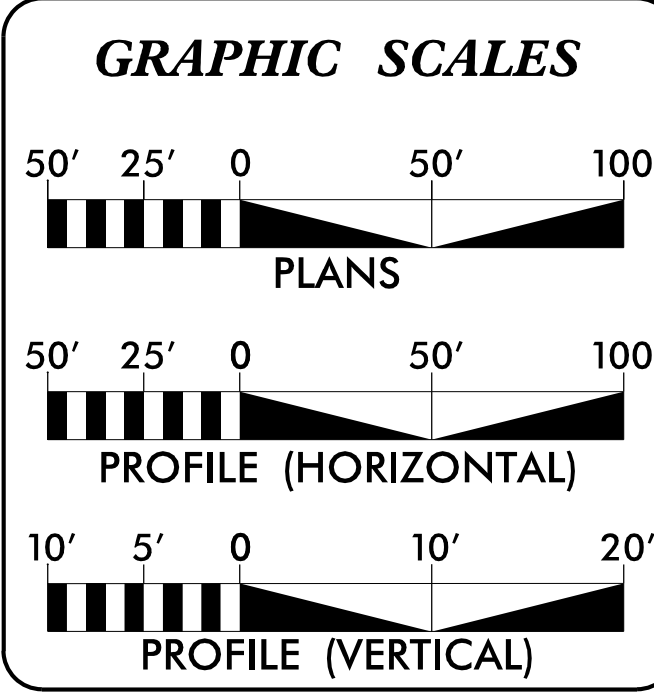

**DESIGN DATA**

ADT 2023 =	22713
ADT 2043 =	24463
K =	8 %
D =	55 %
T =	4 % *
V =	50 MPH
* TTST =	1% DUAL = 3%
FUNC CLASS =	MINOR ARTERIAL REGIONAL TIER

**PROJECT LENGTH**

LENGTH ROADWAY TIP PROJECT U-5824 =	1.807 MILES
TOTAL LENGTH TIP PROJECT U-5824 =	1.807 MILES

CONNIE JAMES, PE  
NCDOT CONTACT, DIVISION 9

Prepared in the Office of:

**SUMMIT**  
DESIGN AND ENGINEERING SERVICES  
FIRM NO. P-0339

320 Executive Court  
Hillsborough, NC 27278-8551  
Voice: (919) 732-3883  
Fax: (919) 732-6776  
www.summitde.com

2018 STANDARD SPECIFICATIONS

**RIGHT OF WAY DATE:**  
FEBRUARY 22, 2020

**LETTING DATE:**  
NOVEMBER 21, 2023

**NEIL J. DEAN, PE**  
PROJECT ENGINEER

**FAITH E. JAHNKE, PE**  
PROJECT DESIGN ENGINEER

**HYDRAULICS ENGINEER**

9/15/2023

DocuSigned by:  
*He Yang*  
SIGNATURE

**ROADWAY DESIGN ENGINEER**



9/15/2023

DocuSigned by:  
*Faith E. Jahnke*  
SIGNATURE

★ PROPOSED SIGNAL

DOCUMENT NOT CONSIDERED FINAL  
UNLESS ALL SIGNATURES COMPLETED

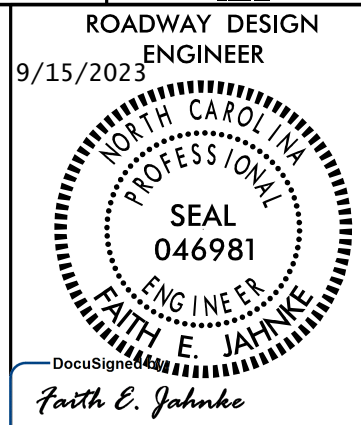
8/17/99

PROJECT REFERENCE NO. <i>U-5824</i>	SHEET NO. <i>1A</i>
ROADWAY DESIGN ENGINEER 9/15/2023	
	
<b>DOCUMENT NOT CONSIDERED FINAL UNLESS ALL SIGNATURES COMPLETED</b>	
Prepared in the Office of:	
	<small>NC FIRM LICENSE No. P-0339 420 Executive Ct. Hillsborough, NC 27278 (919) 732-3883 (919) 732-6676 (Fax)</small>

	INDEX OF SHEETS	EFF. 01-16-2018 REV.
SHEET NUMBER	SHEET	2018 ROADWAY ENGLISH STANDARD DRAWINGS
1	TITLE SHEET	The following Roadway Standards as appear in "Roadway Standard Drawings" Highway Design Branch - N. C. Department of Transportation - Raleigh, N. C., Dated January, 2018 are applicable to this project and by reference hereby are considered a part of these plans:
1A	INDEX OF SHEETS, GENERAL NOTES, AND STANDARD DRAWINGS	
1B	CONVENTIONAL SYMBOLS	STD. NO. TITLE
2A-1 THRU 2A-5	PAVEMENT SCHEDULE AND TYPICAL SECTIONS	DIVISION 2 - EARTHWORK 200.03 Method of Clearing - Method III 225.02 Guide for Grading Subgrade - Secondary and Local 225.04 Method of Obtaining Super-elevation - Two Lane Pavement 225.06 Method of Grading Sight Distance at Intersections
2B-1 THRU 2B-13	ROADWAY DETAILS	DIVISION 3 - PIPE CULVERTS 300.01 Method of Pipe Installation 310.10 Driveway Pipe Construction
2C-1 THRU 2C-14	SPECIAL DETAILS	DIVISION 5 - SUBGRADE, BASES AND SHOULDERS 560.01 Method of Shoulder Construction - High Side of Super-elevated Curve - Method I
3B-1 THRU 3B-2	ROADWAY SUMMARIES	DIVISION 6 - ASPHALT BASES AND PAVEMENTS 654.01 Pavement Repairs
3D-1 THRU 3D-11	DRAINAGE SUMMARIES	DIVISION 8 - INCIDENTALS 806.01 Concrete Right-of-Way Marker 806.02 Granite Right-of-Way Marker 815.02 Subsurface Drain 838.01 Concrete Endwall for Single and Double Pipe Culverts - 15" thru 48" Pipe 90 Skew 838.11 Brick Endwall for Single and Double Pipe Culverts - 15" thru 48" Pipe 90 Skew 838.27 Reinforced Concrete Endwall - for Single 60" Pipe 90 Skew 838.45 Notes for Reinforced Concrete Endwall - Std. Dwg 838.21 thru 838.40 838.57 Reinforced Brick Endwall - for Single 60" Pipe 90 Skew 838.75 Notes for Reinforced Brick Endwall - Std. Dwg 838.51 thru 838.70 838.80 Precast Endwalls - 12" thru 72" Pipe 90 Skew 840.00 Concrete Base Pad for Drainage Structures 840.01 Brick Catch Basin - 12" thru 54" Pipe 840.02 Concrete Catch Basin - 12" thru 54" Pipe 840.03 Frame, Grates and Hood - for Use on Standard Catch Basin 840.14 Concrete Drop Inlet - 12" thru 30" Pipe 840.15 Brick Drop Inlet - 12" thru 30" Pipe 840.16 Drop Inlet Frame and Grates - for use with Std. Dwg 840.14 and 840.15 840.17 Concrete Grated Drop Inlet Type 'A' - 12" thru 72" Pipe 840.24 Frames and Narrow Slot Sag Grates 840.25 Anchorage for Frames - Brick or Concrete or Precast 840.26 Brick Grated Drop Inlet Type 'A' - 12" thru 72" Pipe 840.29 Frames and Narrow Slot Flat Grates 840.31 Concrete Junction Box - 12" thru 66" Pipe 840.32 Brick Junction Box - 12" thru 66" Pipe 840.35 Traffic Bearing Grated Drop Inlet - for Cast Iron Double Frame and Grates 840.45 Precast Drainage Structure 840.46 Traffic Bearing Precast Drainage Structure 840.54 Manhole Frame and Cover 840.66 Drainage Structure Steps 840.71 Concrete and Brick Pipe Plug 846.01 Concrete Curb, Gutter and Curb & Gutter 848.01 Concrete Sidewalk 848.02 Driveway Turnout - Radius Type 848.04 Street Turnout 848.05 Curb Ramp - Proposed Curb & Gutter 850.01 Concrete Paved Ditches 852.01 Concrete Islands 852.04 Method for Placement of Drop Inlets in Grassed Median - Using 1'-6" Curb and Gutter 852.05 Median Curb for Catch Basin - for Use with 1'-6" Curb and Gutter 852.06 Method for Placement of Drop Inlets in Concrete Islands 862.01 Guardrail Placement 862.02 Guardrail Installation 876.01 Rip Rap in Channels 876.02 Guide for Rip Rap at Pipe Outlets 876.04 Drainage Ditches with Class 'B' Rip Rap
3G-1	GEOTECHNICAL SUMMARIES	
3P-1	PARCEL INDEX SHEET	
4 THRU 19	PLAN AND PROFILE SHEET	
RW-1 THRU RW-11	SURVEY CONTROL, EXISTING CENTERLINES, RIGHT OF WAY, EASEMENT AND PROPERTY TIES	
TMP-1 THRU TMP-10A	TRAFFIC MANAGEMENT PLANS	
PMP-1 THRU PMP-9	PAVEMENT MARKING PLANS	
EC-1 THRU EC-19	EROSION CONTROL PLANS	
SIGN-1 THRU SIGN-9	SIGNING PLANS	
SIG-1 THRU SIG-16.2	SIGNAL PLANS	
SCP-1 THRU SCP-2	SIGNAL COMMUNICATION PLANS	
UC-1 THRU UC-20	UTILITIES CONSTRUCTION PLANS	
UD-1 THRU UD-9	UTILITIES BY OTHERS PLANS	
X-0	CROSS-SECTION INDEX	
X-1A THRU X-1C	CROSS-SECTION SUMMARY SHEET	
X-1 THRU X-66	CROSS-SECTIONS	
W-1 THRU W-5	WALL PLANS	

GENERAL NOTES: 2018 SPECIFICATIONS  
EFFECTIVE: 01-16-2024  
REVISED:

GRADING AND SURFACING OR RESURFACING AND WIDENING:  
THE GRADE LINES SHOWN DENOTE THE FINISHED ELEVATION OF THE PROPOSED SURFACING AT GRADE POINTS SHOWN ON THE TYPICAL SECTIONS. WHERE NO GRADE LINES ARE SHOWN, THE PROFILES SHOWN DENOTE THE TOP ELEVATION OF THE EXISTING PAVEMENT ALONG THE CENTER LINE OF SURVEY ON WHICH THE PROPOSED RESURFACING WILL BE PLACED. GRADE LINES MAY BE ADJUSTED BY THE ENGINEER IN ORDER TO SECURE A PROPER TIE-IN.

CLEARING:  
CLEARING ON THIS PROJECT SHALL BE PERFORMED TO THE LIMITS ESTABLISHED BY METHOD III.

SUPERELEVATION:  
ALL CURVES ON THIS PROJECT SHALL BE SUPERELEVATED IN ACCORDANCE WITH STD. NO. 225.04 USING THE RATE OF SUPERELEVATION AND RUNOFF SHOWN ON THE PLANS. SUPERELEVATION IS TO BE REVOLVED ABOUT THE GRADE POINTS SHOWN ON THE TYPICAL SECTIONS.

SHOULDER CONSTRUCTION:  
ASPHALT, EARTH, AND CONCRETE SHOULDER CONSTRUCTION ON THE HIGH SIDE OF SUPERELEVATED CURVES SHALL BE IN ACCORDANCE WITH STD. NO. 560.01

SIDE ROADS:  
THE CONTRACTOR WILL BE REQUIRED TO DO ALL NECESSARY WORK TO PROVIDE SUITABLE CONNECTIONS WITH ALL ROADS, STREETS, AND DRIVES ENTERING THIS PROJECT. THIS WORK WILL BE PAID FOR AT THE CONTRACT UNIT PRICE FOR THE PARTICULAR ITEMS INVOLVED.

SUBSURFACE DRAINS:  
SUBSURFACE DRAINS SHALL BE CONSTRUCTED IN ACCORDANCE WITH STD. NO. 815.02 AT LOCATIONS DIRECTED BY THE ENGINEER.

DRIVEWAYS:  
DRIVEWAYS SHALL BE CONSTRUCTED IN ACCORDANCE WITH STD. 848.02 USING 3 FOOT RADI1 OR RADI11 AS SHOWN ON THE PLANS. LOCATIONS OF DRIVES WILL BE AS SHOWN ON THE PLANS OR AS DIRECTED BY THE ENGINEER.

STREET TURNOUT:  
STREET RETURNS SHALL BE CONSTRUCTED IN ACCORDANCE WITH STD. NO. 848.04 USING THE RADI11 NOTED ON PLANS.

GUARDRAIL:  
THE GUARDRAIL LOCATIONS SHOWN ON THE PLANS MAY BE ADJUSTED DURING CONSTRUCTION AS DIRECTED BY THE ENGINEER. THE CONTRACTOR SHOULD CONSULT WITH THE ENGINEER PRIOR TO ORDERING GUARDRAIL MATERIAL.

TEMPORARY SHORING:  
SHORING REQUIRED FOR THE MAINTENANCE OF TRAFFIC WILL BE PAID FOR AS "EXTRA WORK" IN ACCORDANCE WITH SECTION 104-7.

UTILITIES:  
UTILITY OWNERS ON THIS PROJECT ARE DUKE ENERGY,  
PIEDMONT NATURAL GAS, CENTURYLINK, SPECTURM,  
CITY OF WINSTON-SALEM  
ANY RELOCATION OF EXISTING UTILITIES WILL BE ACCOMPLISHED BY OTHERS, EXCEPT AS SHOWN ON THE PLANS.

RIGHT-OF-WAY MARKERS:  
ALL RIGHT-OF-WAY MARKERS ON THIS PROJECT SHALL BE PLACED BY CONTRACT.

CURB RAMPS  
CURB RAMPS ARE SHOWN ON THE PLANS AT APPROXIMATE LOCATIONS.  
CONSTRUCT ALL CURB RAMPS ACCORDANCE WITH STD 848.06.

14-SEP-2023 13:51  
U:\5824\_Road\1A.dgn  
Faith E. Jahnke



# STATE OF NORTH CAROLINA, DIVISION OF HIGHWAYS CONVENTIONAL PLAN SHEET SYMBOLS

Note: Not to Scale

## BOUNDARIES AND PROPERTY:

State Line	-----
County Line	-----
Township Line	-----
City Line	-----
Reservation Line	-----
Property Line	-----
Existing Iron Pin (EIP)	○
Computed Property Corner	×
Existing Concrete Monument (ECM)	□
Parcel/Sequence Number	(123)
Existing Fence Line	-x-x-x-
Proposed Woven Wire Fence	○
Proposed Chain Link Fence	□
Proposed Barbed Wire Fence	◇
Existing Wetland Boundary	WLB
Proposed Wetland Boundary	WLB
Existing Endangered Animal Boundary	EAB
Existing Endangered Plant Boundary	EPB
Existing Historic Property Boundary	HPB
Known Contamination Area: Soil	☒-s-☒-s-
Potential Contamination Area: Soil	☒-s-☒-s-
Known Contamination Area: Water	☒-w-☒-w-
Potential Contamination Area: Water	☒-w-☒-w-
Contaminated Site: Known or Potential	☠☒☒

## BUILDINGS AND OTHER CULTURE:

Gas Pump Vent or U/G Tank Cap	○
Sign	○
Well	○
Small Mine	×
Foundation	□
Area Outline	□
Cemetery	□
Building	□
School	□
Church	□
Dam	□

## HYDROLOGY:

Stream or Body of Water	-----
Hydro, Pool or Reservoir	-----
Jurisdictional Stream	JS
Buffer Zone 1	BZ 1
Buffer Zone 2	BZ 2
Flow Arrow	←
Disappearing Stream	→
Spring	○
Wetland	WLB
Proposed Lateral, Tail, Head Ditch	-----
False Sump	▽

## RAILROADS:

Standard Gauge	-----
RR Signal Milepost	○
Switch	□
RR Abandoned	-----
RR Dismantled	-----

## RIGHT OF WAY & PROJECT CONTROL:

Primary Horiz Control Point	○
Primary Horiz and Vert Control Point	●
Secondary Horiz and Vert Control Point	◆
Vertical Benchmark	⊕
Existing Right of Way Monument	△
Proposed Right of Way Monument (Rebar and Cap)	▲
Proposed Right of Way Monument (Concrete)	▲
Existing Permanent Easement Monument	◇
Proposed Permanent Easement Monument (Rebar and Cap)	◆
Existing C/A Monument	△
Proposed C/A Monument (Rebar and Cap)	▲
Proposed C/A Monument (Concrete)	▲
Existing Right of Way Line	-----
Proposed Right of Way Line	-----
Existing Control of Access Line	-----
Proposed Control of Access Line	-----
Proposed ROW and CA Line	-----
Existing Easement Line	-----
Proposed Temporary Construction Easement	E
Proposed Temporary Drainage Easement	TDE
Proposed Permanent Drainage Easement	PDE
Proposed Permanent Drainage/Utility Easement	DUE
Proposed Permanent Utility Easement	PUE
Proposed Temporary Utility Easement	TUE
Proposed Aerial Utility Easement	AUE

## ROADS AND RELATED FEATURES:

Existing Edge of Pavement	-----
Existing Curb	-----
Proposed Slope Stakes Cut	C
Proposed Slope Stakes Fill	F
Proposed Curb Ramp	CR
Existing Metal Guardrail	T
Proposed Guardrail	T
Existing Cable Guiderail	□
Proposed Cable Guiderail	□
Equality Symbol	⊕
Pavement Removal	⊗
VEGETATION:	
Single Tree	○
Single Shrub	○
Hedge	-----

Woods Line	-----
Orchard	○
Vineyard	□

## EXISTING STRUCTURES:

MAJOR:	
Bridge, Tunnel or Box Culvert	CONC
Bridge Wing Wall, Head Wall and End Wall	CONC WW
MINOR:	
Head and End Wall	CONC HW
Pipe Culvert	-----
Footbridge	-----
Drainage Box: Catch Basin, DI or JB	CB
Paved Ditch Gutter	-----
Storm Sewer Manhole	○
Storm Sewer	S

## UTILITIES:

\* SUE - Subsurface Utility Engineering  
LOS - Level of Service - A,B,C or D (Accuracy)

POWER:	
Existing Power Pole	●
Proposed Power Pole	○
Existing Joint Use Pole	●
Proposed Joint Use Pole	○
Power Manhole	○
Power Line Tower	□
Power Transformer	⊗
U/G Power Cable Hand Hole	PH
H-Frame Pole	●
U/G Power Line Test Hole (SUE - LOS A)*	⊗
U/G Power Line (SUE - LOS B)*	P
U/G Power Line (SUE - LOS C)*	P
U/G Power Line (SUE - LOS D)*	P

## TELEPHONE:

Existing Telephone Pole	●
Proposed Telephone Pole	○
Telephone Manhole	○
Telephone Pedestal	□
Telephone Cell Tower	⊕
U/G Telephone Cable Hand Hole	PH
U/G Telephone Test Hole (SUE - LOS A)*	⊗
U/G Telephone Cable (SUE - LOS B)*	T
U/G Telephone Cable (SUE - LOS C)*	T
U/G Telephone Cable (SUE - LOS D)*	T
U/G Telephone Conduit (SUE - LOS B)*	TC
U/G Telephone Conduit (SUE - LOS C)*	TC
U/G Telephone Conduit (SUE - LOS D)*	TC
U/G Fiber Optics Cable (SUE - LOS B)*	T FO
U/G Fiber Optics Cable (SUE - LOS C)*	T FO
U/G Fiber Optics Cable (SUE - LOS D)*	T FO

## WATER:

Water Manhole	○
Water Meter	○
Water Valve	⊗
Water Hydrant	⊕
U/G Water Line Test Hole (SUE - LOS A)*	⊗
U/G Water Line (SUE - LOS B)*	P
U/G Water Line (SUE - LOS C)*	P
U/G Water Line (SUE - LOS D)*	P
Above Ground Water Line	A/G Water
TV:	
TV Pedestal	□
TV Tower	⊗
U/G TV Cable Hand Hole	PH
U/G TV Test Hole (SUE - LOS A)*	⊗
U/G TV Cable (SUE - LOS B)*	TV
U/G TV Cable (SUE - LOS C)*	TV
U/G TV Cable (SUE - LOS D)*	TV
U/G Fiber Optic Cable (SUE - LOS B)*	TV FO
U/G Fiber Optic Cable (SUE - LOS C)*	TV FO
U/G Fiber Optic Cable (SUE - LOS D)*	TV FO

## GAS:

Gas Valve	◇
Gas Meter	⊕
U/G Gas Line Test Hole (SUE - LOS A)*	⊗
U/G Gas Line (SUE - LOS B)*	G
U/G Gas Line (SUE - LOS C)*	G
U/G Gas Line (SUE - LOS D)*	G
Above Ground Gas Line	A/G Gas

## SANITARY SEWER:

Sanitary Sewer Manhole	⊕
Sanitary Sewer Cleanout	⊕
U/G Sanitary Sewer Line	SS
Above Ground Sanitary Sewer	A/G Sanitary Sewer
SS Force Main Line Test Hole (SUE - LOS A)*	⊗
SS Force Main Line (SUE - LOS B)*	FSS
SS Force Main Line (SUE - LOS C)*	FSS
SS Force Main Line (SUE - LOS D)*	FSS

## MISCELLANEOUS:

Utility Pole	●
Utility Pole with Base	□
Utility Located Object	○
Utility Traffic Signal Box	⊕
Utility Unknown U/G Line (SUE - LOS B)*	UTL
U/G Tank; Water, Gas, Oil	□
Underground Storage Tank, Approx. Loc.	UST
A/G Tank; Water, Gas, Oil	□
Geoenvironmental Boring	⊕
Abandoned According to Utility Records	AATUR
End of Information	E.O.I.

6/2/2023

### PAVEMENT SCHEDULE

(FINAL PAVEMENT DESIGN)

Prepared in the Office of: **SUMMIT**  
NC FIRM LICENSE No. P-0339  
 320 Executive Ct.  
 Hillsborough, NC 27278  
 (919) 732-3883  
 (919) 732-6676 (FAX)

PROJECT REFERENCE NO. **U-5824** SHEET NO. **2A-1**

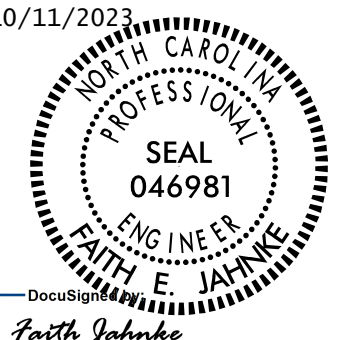
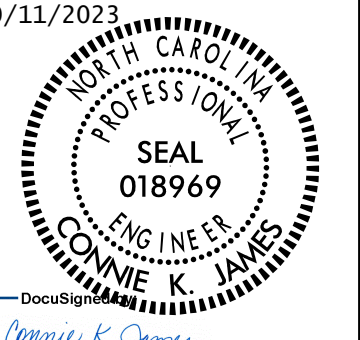
ROADWAY DESIGN ENGINEER 10/11/2023  Faith E. Jahnke	PAVEMENT DESIGN ENGINEER 10/11/2023  Connie K. James
--	---

**DOCUMENT NOT CONSIDERED FINAL UNLESS ALL SIGNATURES COMPLETED**

<b>C1</b>	PROP. APPROX. 1½" ASPHALT CONCRETE SURFACE COURSE, TYPE S9.5B, AT AN AVERAGE RATE OF 165 LBS. PER SQ. YD.	<b>E3</b>	PROP. VAR. DEPTH ASPHALT CONCRETE BASE COURSE, TYPE B25.0C, AT AN AVERAGE RATE OF 114 LBS. PER SQ. YD. PER 1" DEPTH. TO BE PLACED IN LAYERS NOT LESS THAN 3" IN DEPTH OR GREATER THAN 5½" IN DEPTH.
<b>C2</b>	PROP. APPROX. 3" ASPHALT CONCRETE SURFACE COURSE, TYPE S9.5B, AT AN AVERAGE RATE OF 165 LBS. PER SQ. YD. IN EACH OF TWO LAYERS.	<b>K</b>	PROP. 12" CLASS IV SUBGRADE STABILIZATION.
<b>C3</b>	PROP. APPROX. 2.5" ASPHALT CONCRETE SURFACE COURSE, TYPE S9.5B, AT AN AVERAGE RATE OF 137.5 LBS. PER SQ. YD. IN EACH OF TWO LAYERS.	<b>N</b>	GEOTEXTILE FOR SUBGRADE STABILIZATION.
<b>C4</b>	PROP. VAR. DEPTH ASPHALT CONCRETE SURFACE COURSE, TYPE S9.5B, AT AN AVERAGE RATE OF 110 LBS. PER SQ. YD. PER 1" DEPTH. TO BE PLACED IN LAYERS NOT TO EXCEED 1½" IN DEPTH.	<b>R1</b>	1'-6" CONCRETE CURB AND GUTTER.
<b>D1</b>	PROP. APPROX. 4" ASPHALT CONCRETE INTERMEDIATE COURSE, TYPE I19.0C, AT AN AVERAGE RATE OF 456 LBS. PER SQ. YD.	<b>R2</b>	2'-6" CONCRETE CURB AND GUTTER.
<b>D2</b>	PROP. VAR. DEPTH ASPHALT CONCRETE INTERMEDIATE COURSE, TYPE I19.0C, AT AN AVERAGE RATE OF 114 LBS. PER SQ. YD. PER 1" DEPTH, TO BE PLACED IN LAYERS NOT LESS THAN 2½" IN DEPTH OR GREATER THAN 4" IN DEPTH.	<b>R3</b>	2'-9" CONCRETE CURB AND GUTTER.
<b>E1</b>	PROP. APPROX. 4" ASPHALT CONCRETE BASE COURSE, TYPE B25.0C, AT AN AVERAGE RATE OF 456 LBS. PER SQ. YD.	<b>R4</b>	5" MONOLITHIC CONCRETE ISLAND (KEYED-IN)
<b>E2</b>	PROP. APPROX. 5" ASPHALT CONCRETE BASE COURSE, TYPE B25.0C, AT AN AVERAGE RATE OF 570 LBS. PER SQ. YD.	<b>R5</b>	8"x18" CONCRETE CURB

<b>S</b>	4" SIDEWALK
<b>T</b>	EARTH MATERIAL.
<b>U</b>	EXISTING PAVEMENT.
<b>V1</b>	INCIDENTAL MILLING
<b>V2</b>	MILLING BITUMINOUS PAVEMENT, 1½" DEPTH
<b>W</b>	VARIABLE DEPTH ASPHALT PAVEMENT (SEE STANDARD WEDGING DETAIL)

NOTE: PAVEMENT EDGE SLOPES ARE 1:1 UNLESS SHOWN OTHERWISE.

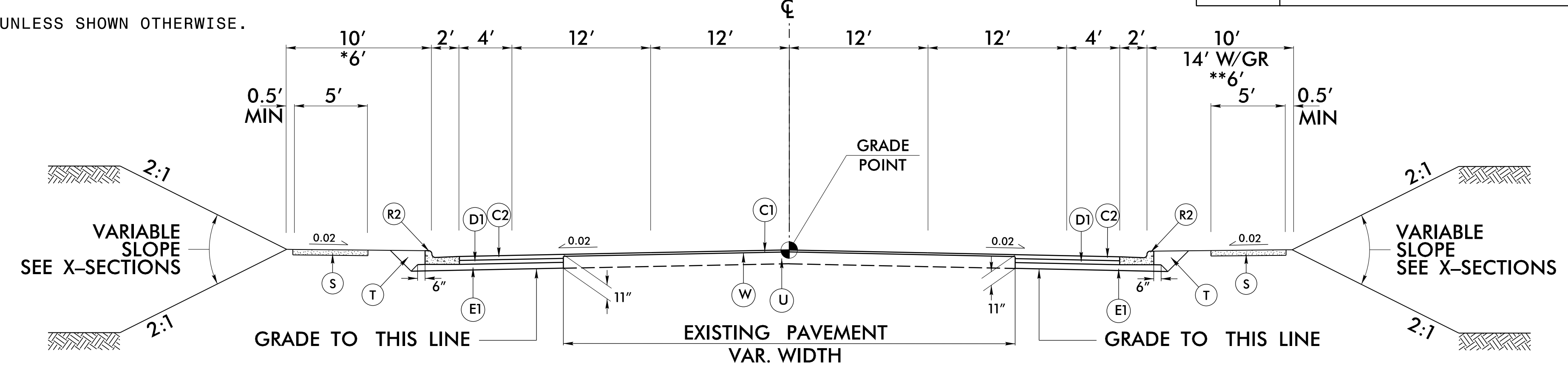

**TYPICAL SECTION NO. 1**

**USE TYPICAL SECTION NO. 1**  
 -L- STA 10+52.50 TO 14+00.00

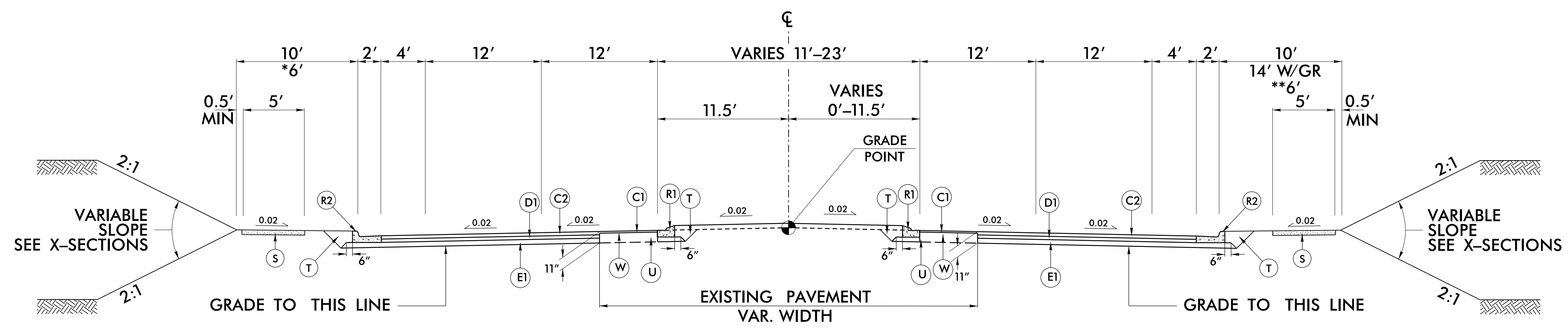

**TYPICAL SECTION NO. 2**

**USE TYPICAL SECTION NO. 2**

\*-L- STA 14+00.00 TO 17+50.00    -L- STA 73+08.00 TO 98+74.06  
 \*\*-L- STA 17+50.00 TO 20+59.00    -L- STA 99+45.94 TO 106+65.31

11/01/2023 09:13  
 U-5824-PAV  
 Faith E. Jahnke



6/2/2019

PAVEMENT SCHEDULE (FINAL PAVEMENT DESIGN)	
C1	1 1/2" S9.5B
C2	3" S9.5B
C3	2.5" S9.5B
C4	VAR. S9.5B
D1	4" I19.0C
D2	VAR. I19.0C
E1	4" B25.0C
E2	5" B25.0C
E3	VAR. B25.0C
K	12" CLASS IV
N	GEOTEXTILE
R1	1'-6" C & G
R2	2'-6" C & G
R3	2'-9" C & G
R4	5" MCI
R5	8"X18" CURB
S	4" SIDEWALK
T	EARTH MATERIAL
U	EXIST. PAVEMENT
V1	INCIDENTAL MILL.
V2	1 1/2" MILLING
W	WEDGING

NOTE: PAVEMENT EDGE SLOPES ARE 1:1 UNLESS SHOWN OTHERWISE.

PROJECT REFERENCE NO. U-5824	SHEET NO. 2A-2
ROADWAY DESIGN ENGINEER 9/15/2023 FAITH E. JAHNKE SEAL 046981 NORTH CAROLINA PROFESSIONAL ENGINEER	PAVEMENT DESIGN ENGINEER 9/15/2023 CONNIE K. JAMES SEAL 018969 NORTH CAROLINA PROFESSIONAL ENGINEER
DOCUMENT NOT CONSIDERED FINAL UNLESS ALL SIGNATURES COMPLETED	
Prepared in the Office of: SUMMIT DESIGN AND ENGINEERING SERVICES	NC FIRM LICENSE No. P-0339 320 Executive Ct. Hillsborough, NC 27278 (919) 732-3883 (919) 732-6676 (FAX)

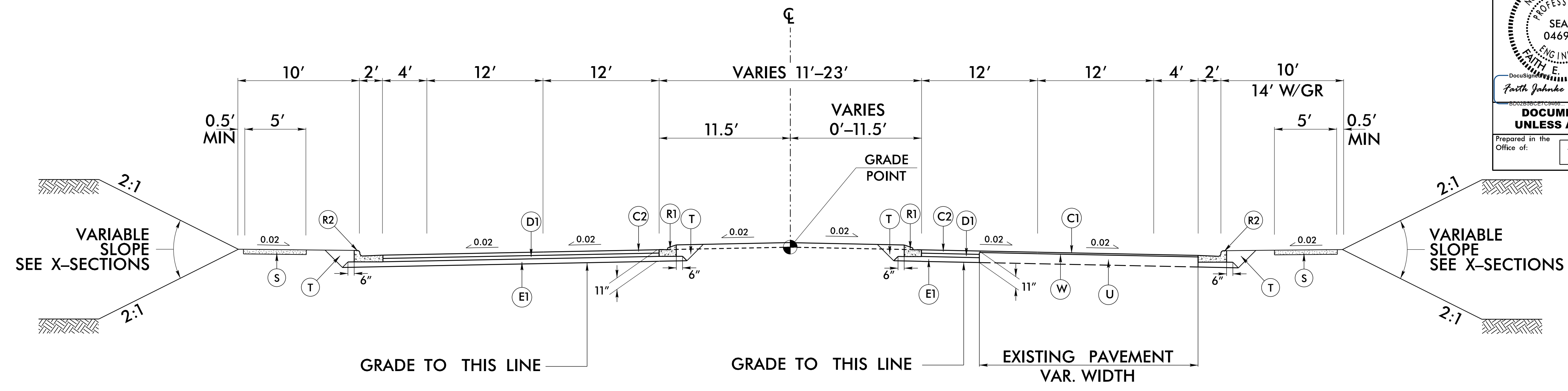

TYPICAL SECTION NO. 3

USE TYPICAL SECTION NO. 3

-L- STA 20+59.00 TO STA 49+25.00

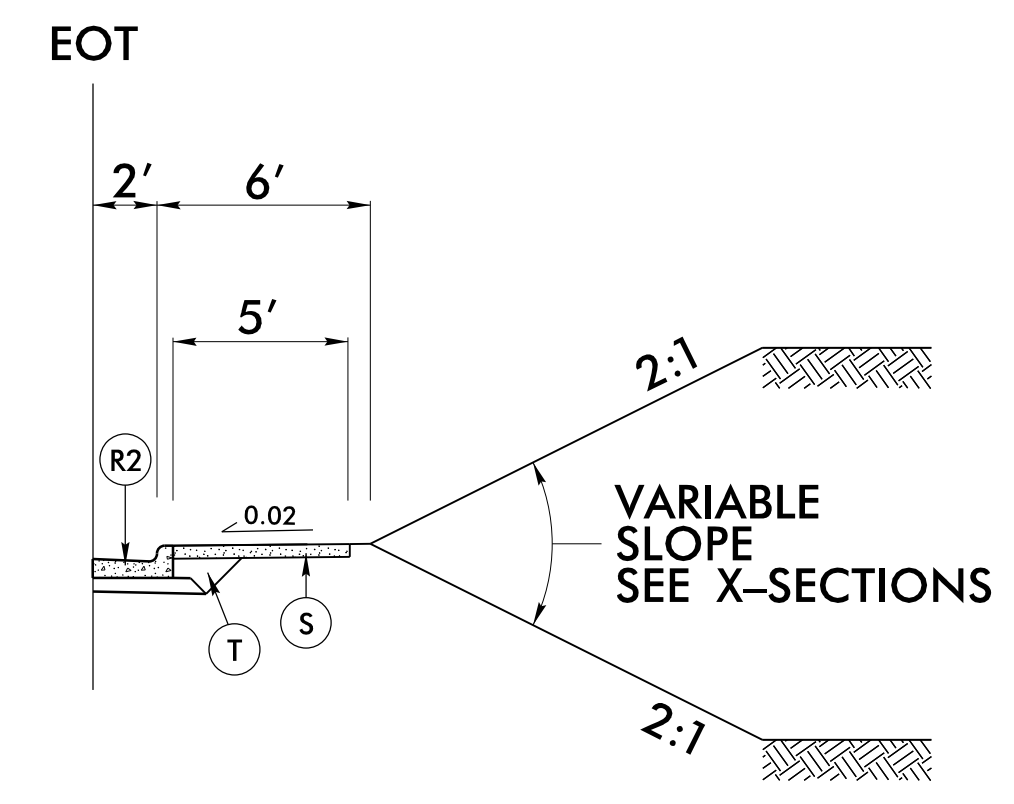

PARTIAL TYPICAL

USE IN CONJUNCTION WITH TYPICAL SECTION NO. 2  
 -L- STA 14+00.00 TO STA 17+50.00 LT  
 -L- STA 17+50.00 TO STA 20+59.00 RT

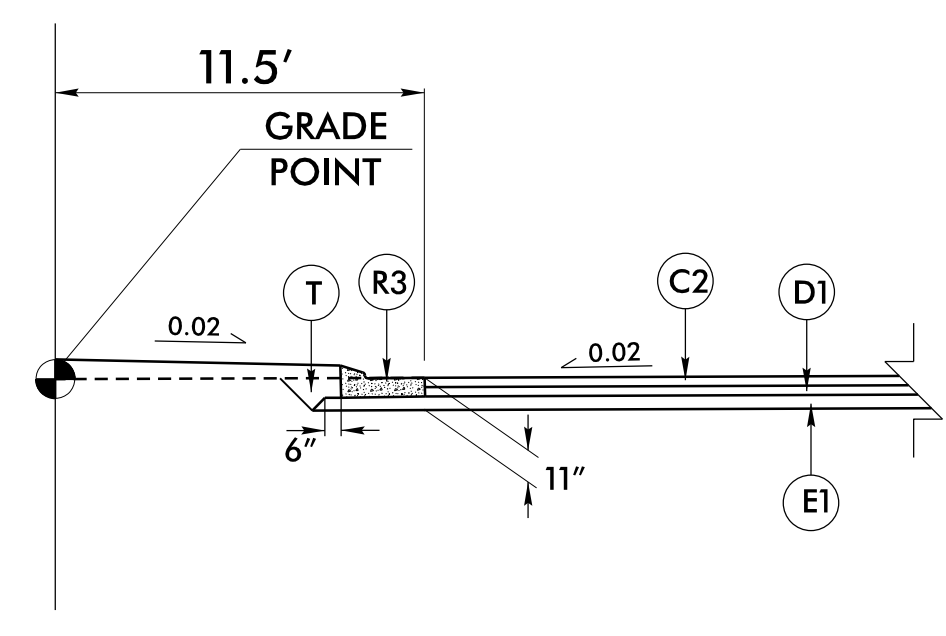

PARTIAL TYPICAL

USE IN CONJUNCTION WITH TYPICAL SECTION NO. 2, 3 & 4  
 -L- STA 17+28.72 TO 21+32.29  
 -L- STA 48+89.71 TO 50+52.75  
 -L- STA 52+24.14 TO 54+20.22  
 -L- STA 93+36.67 TO 96+98.68

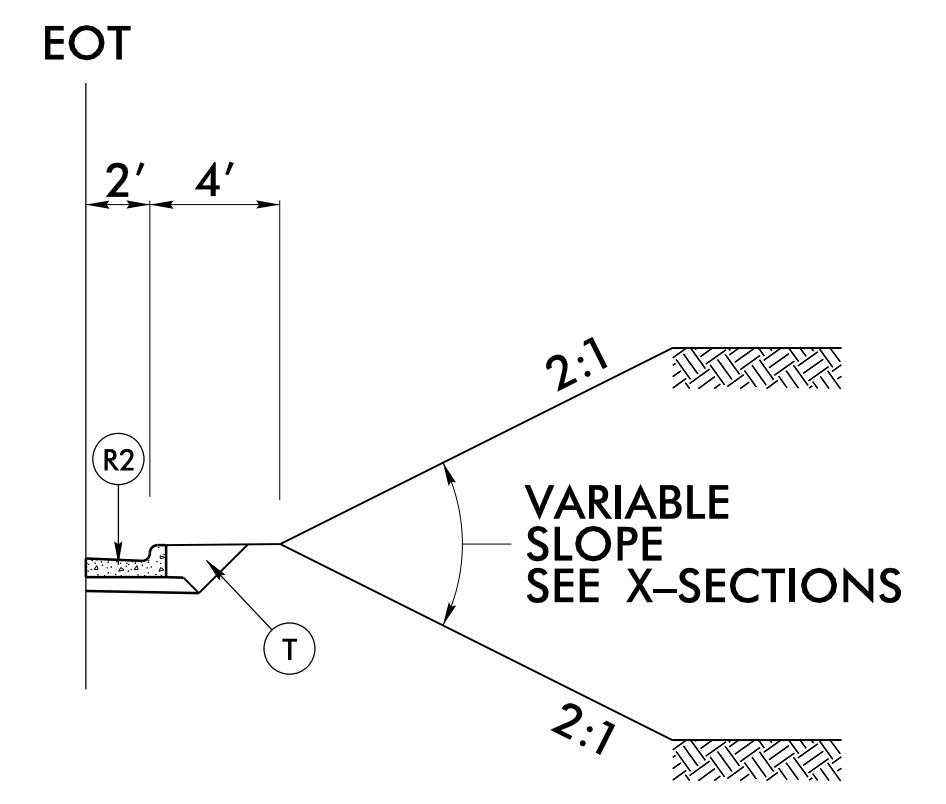

PARTIAL TYPICAL

USE IN CONJUNCTION WITH TYPICAL SECTION NO. 2  
 -L- STA 99+42.30 TO STA 101+82.70

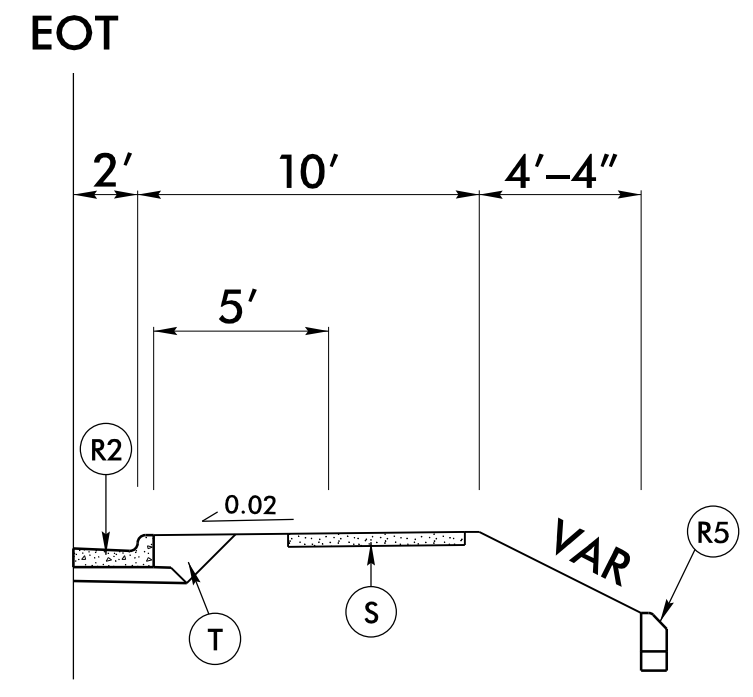

PARTIAL TYPICAL

USE IN CONJUNCTION WITH TYPICAL SECTION NO. 3  
 -L- STA 34+15.40 TO STA 37+89.05 RT  
 -L- STA 44+19.95 TO STA 44+99.00 RT

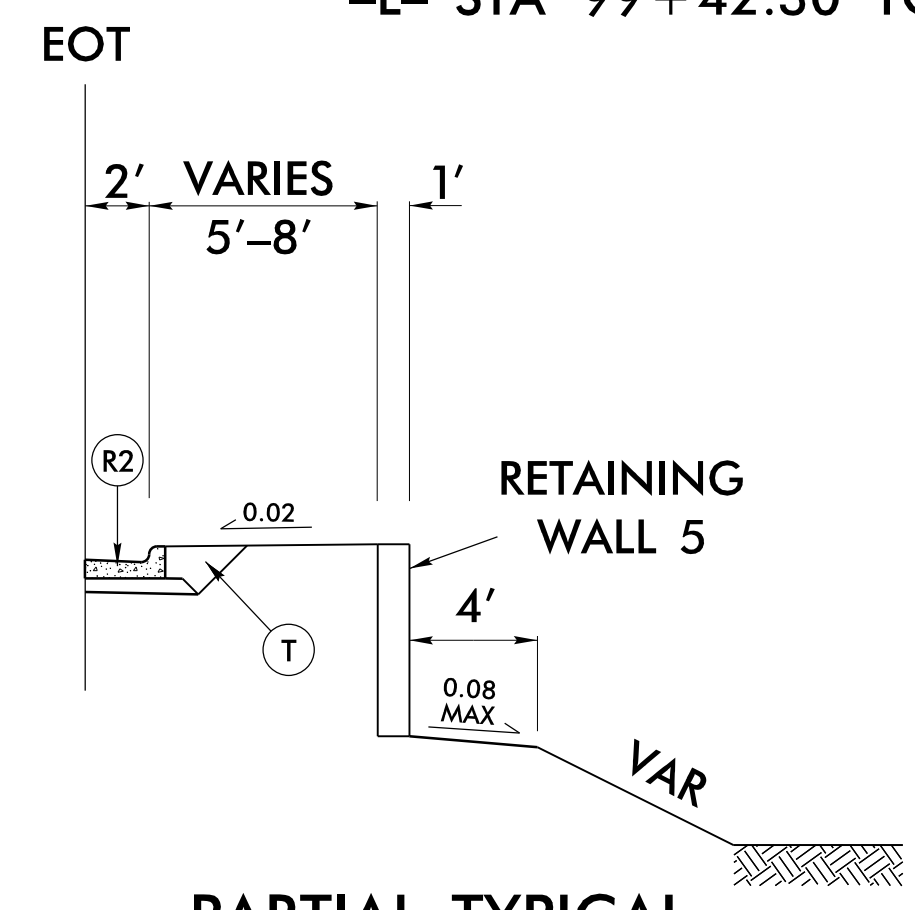

PARTIAL TYPICAL

USE IN CONJUNCTION WITH TYPICAL SECTION NO. 2  
 -L- STA 102+30.00 TO STA 105+50.00

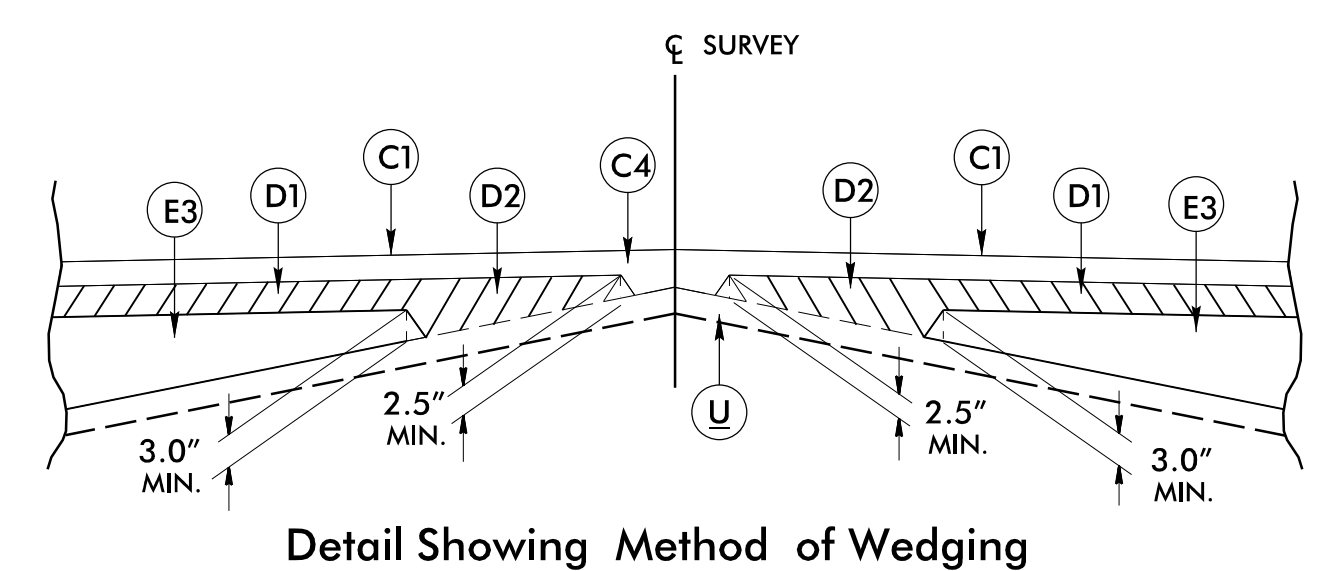

Detail Showing Method of Wedging

14-SEP-2023 15:41  
 U-5824\_R03.dgn  
 faith.jahnke

6/2/2019

PAVEMENT SCHEDULE (FINAL PAVEMENT DESIGN)	
C1	1 1/2" S9.5B
C2	3" S9.5B
C3	2.5" S9.5B
C4	VAR. S9.5B
D1	4" I19.0C
D2	VAR. I19.0C
E1	4" B25.0C
E2	5" B25.0C
E3	VAR. B25.0C
K	12" CLASS IV
N	GEOTEXTILE
R1	1'-6" C & G
R2	2'-6" C & G
R3	2'-9" C & G
R4	5" MCI
R5	8"X18" CURB
S	4" SIDEWALK
T	EARTH MATERIAL
U	EXIST. PAVEMENT
V1	INCIDENTAL MILL.
V2	1 1/2" MILLING
W	WEDGING

NOTE: PAVEMENT EDGE SLOPES ARE 1:1 UNLESS SHOWN OTHERWISE.

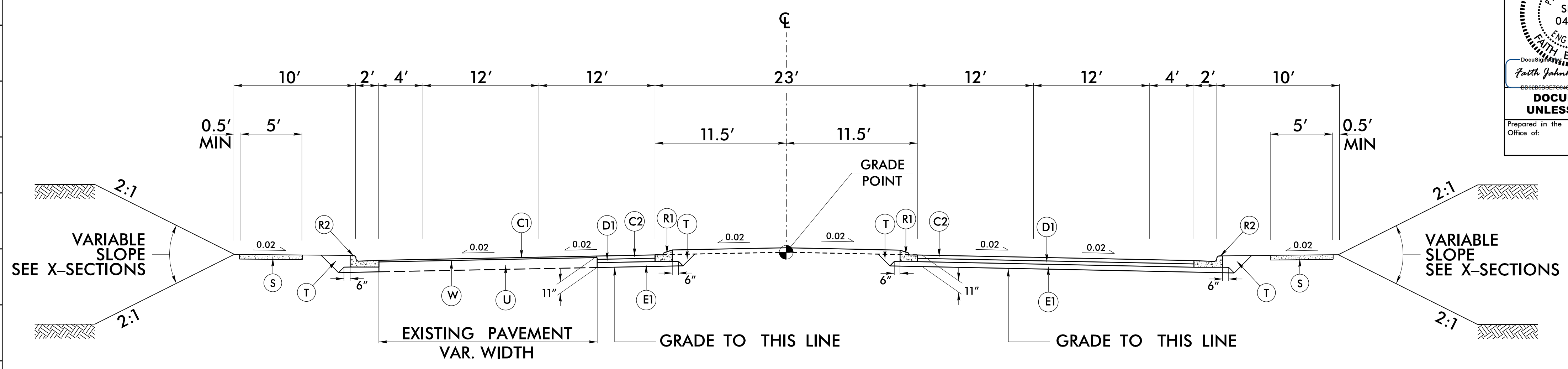

TYPICAL SECTION NO. 4

USE TYPICAL SECTION NO. 4

-L- STA 49+25.00 TO STA 73+08.00

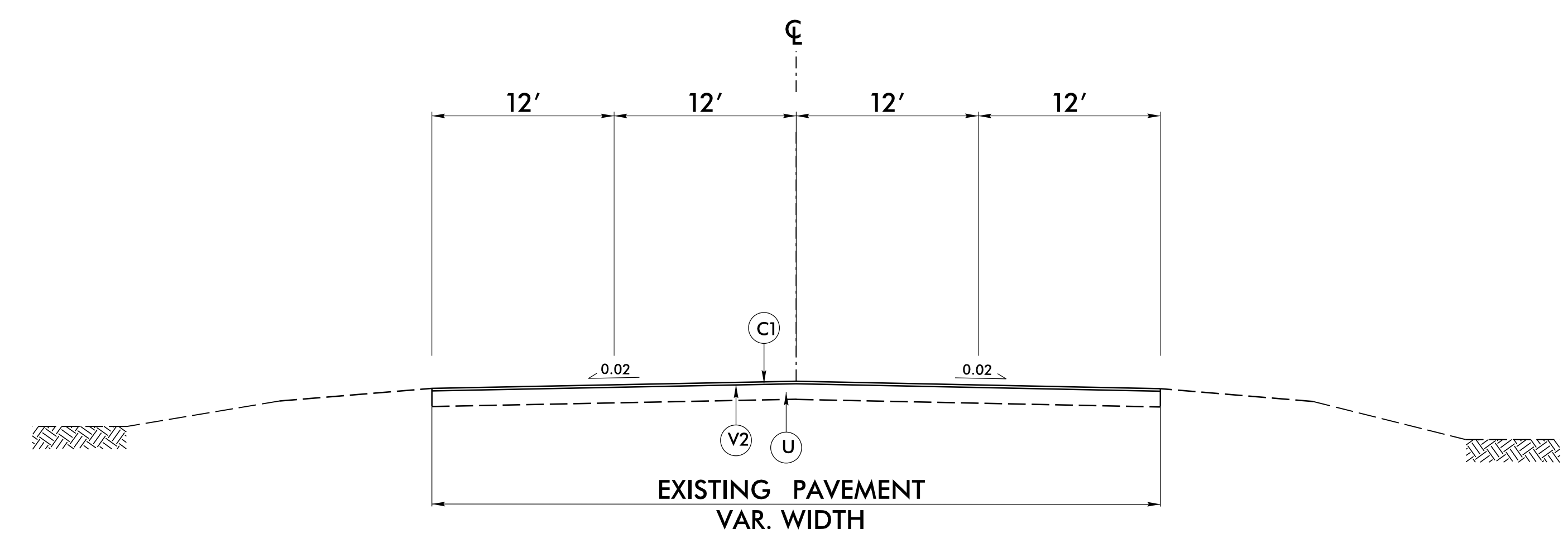

TYPICAL SECTION NO. 5

USE TYPICAL SECTION NO. 5

-L- STA 106+65.31 TO 108+40.00

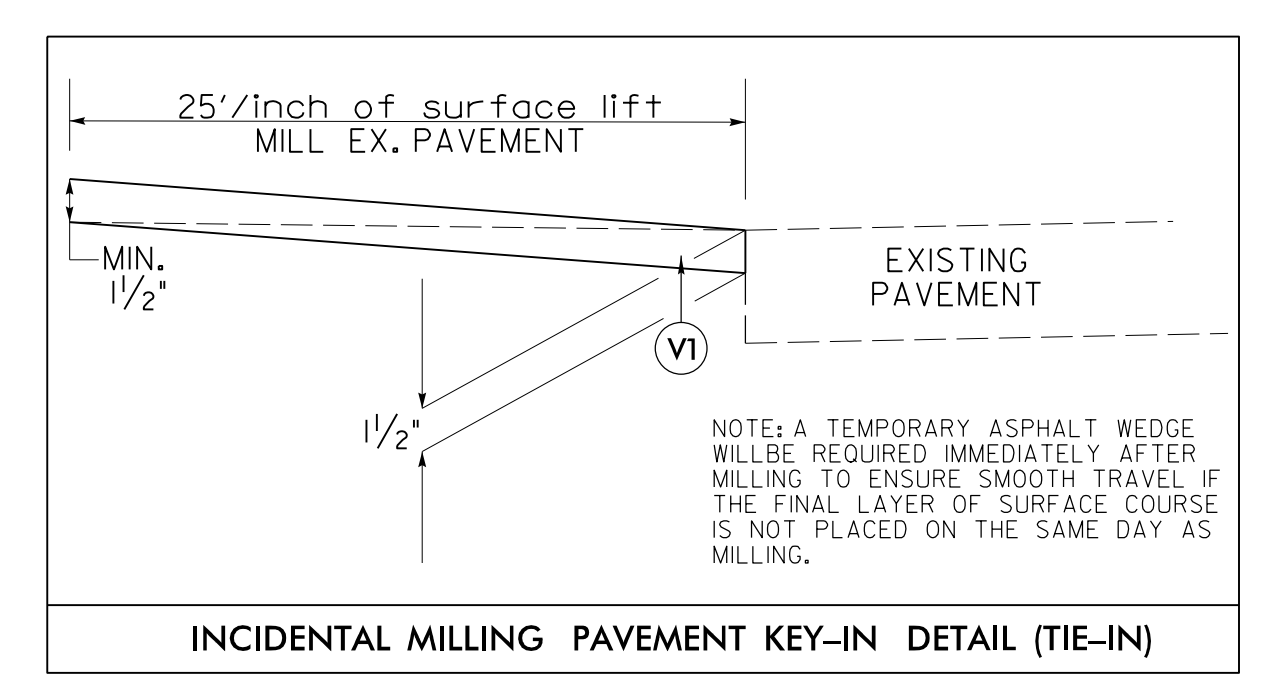

- L- STA 10+52.00 TO 11+27.45
- L- STA 98+01.00 TO 98+78.23
- L- STA 99+41.00 TO 100+19.00
- L- STA 105+90.30 TO 106+65.39
- Y1- 10+75.00 TO 11+12.50
- Y2- 11+37.50 TO 11+75.00
- Y3- 10+25.00 TO 10+62.50
- Y3- 14+87.50 TO 15+25.00
- Y4- 10+00.00 TO 10+37.50
- Y4- 13+37.50 TO 13+75.00
- Y5- 10+92.75 TO 10+55.25
- Y6- 11+62.50 TO 12+00.00
- Y7A- 11+12.50 TO 11+50.00
- Y7B- 12+00.00 TO 12+37.50
- Y8A- 12+55.15 TO 12+92.50
- Y8B- 11+25.00 TO 11+62.50
- Y9- 10+75.00 TO 11+12.50
- Y9- 13+37.50 TO 13+75.00
- Y11A- 10+00.00 TO 10+37.50
- Y11B- 11+87.50 TO 12+25.00

STATION RANGES ARE APPROXIMATE ONLY. GRADE MAY BE ADJUSTED BY ENGINEER TO ENSURE A PROPER TIE-IN.

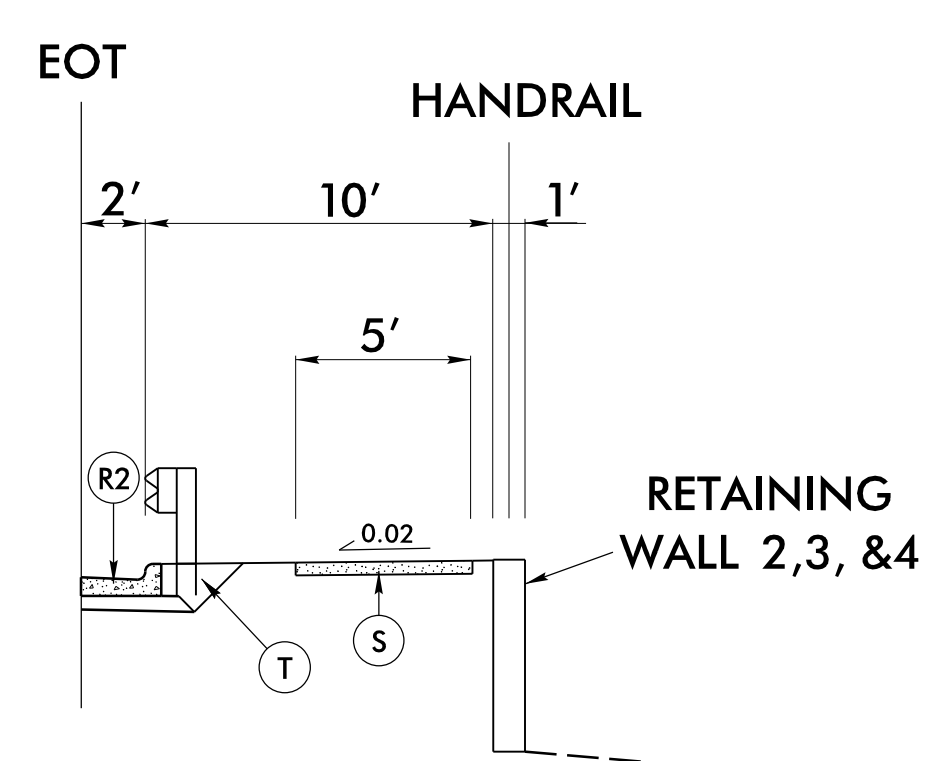

PARTIAL TYPICAL

USE IN CONJUNCTION WITH TYPICAL SECTION NO. 4  
 -L- STA 53+00.00 TO STA 54+50.00 LT  
 -L- STA 53+70.00 TO STA 55+39.79 RT  
 -L- STA 56+17.20 TO STA 59+00.00 RT

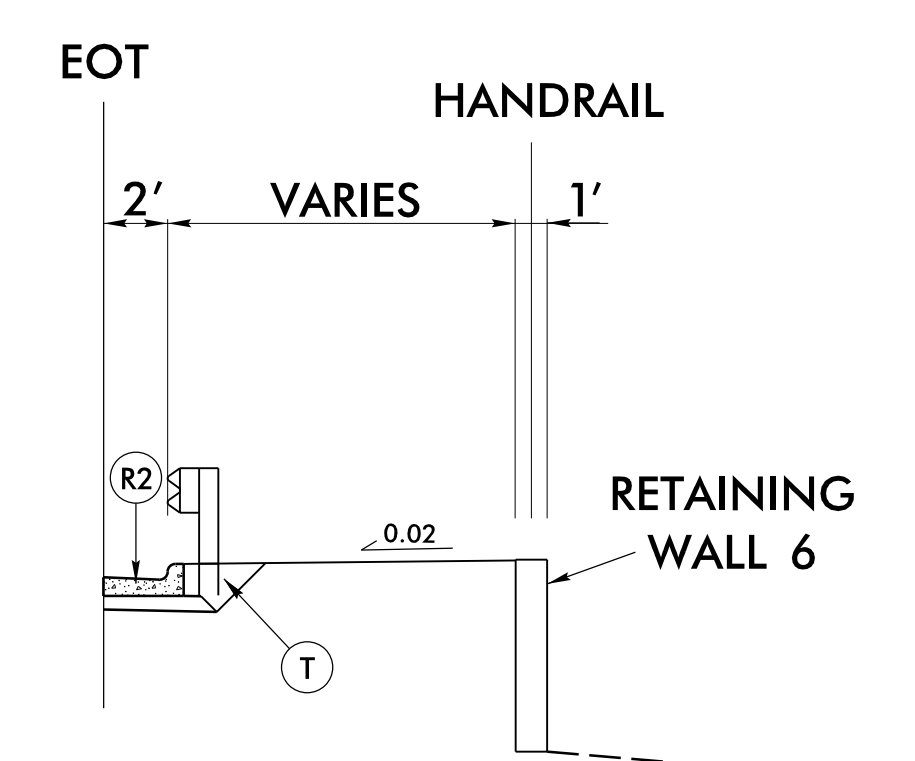

PARTIAL TYPICAL

USE IN CONJUNCTION WITH TYPICAL SECTION NO. 2  
 -L- STA 99+61.00 TO STA 101+00.00 RT

PROJECT REFERENCE NO. U-5824	SHEET NO. 2A-3
ROADWAY DESIGN ENGINEER 9/15/2023 FAITH E. JAHNKE SEAL 046981 ENGINEER	PAVEMENT DESIGN ENGINEER 9/15/2023 CONNIE K. JAMES SEAL 018969 ENGINEER
DOCUMENT NOT CONSIDERED FINAL UNLESS ALL SIGNATURES COMPLETED	
Prepared in the Office of: SUMMIT DESIGN AND ENGINEERING SERVICES	NC FIRM LICENSE No P-0339 320 Executive CT Hillsborough, NC 27278 (919) 732-3883 (919) 732-6676 (FAX)

14-SEP-2023 15:44  
 U-5824\_R03\_2A-3.dgn  
 Faith E. Jahnke



6/2/2019

PAVEMENT SCHEDULE (FINAL PAVEMENT DESIGN)	
C1	1 1/2" S9.5B
C2	3" S9.5B
C3	2.5" S9.5B
C4	VAR. S9.5B
D1	4" I19.0C
D2	VAR. I19.0C
E1	4" B25.0C
E2	5" B25.0C
E3	VAR. B25.0C
K	12" CLASS IV
N	GEOTEXTILE
R1	1'-6" C & G
R2	2'-6" C & G
R3	2'-9" C & G
R4	5" MCI
R5	8"X18" CURB
S	4" SIDEWALK
T	EARTH MATERIAL
U	EXIST. PAVEMENT
V1	INCIDENTAL MILL.
V2	1 1/2" MILLING
W	WEDGING

NOTE: PAVEMENT EDGE SLOPES ARE 1:1 UNLESS SHOWN OTHERWISE.

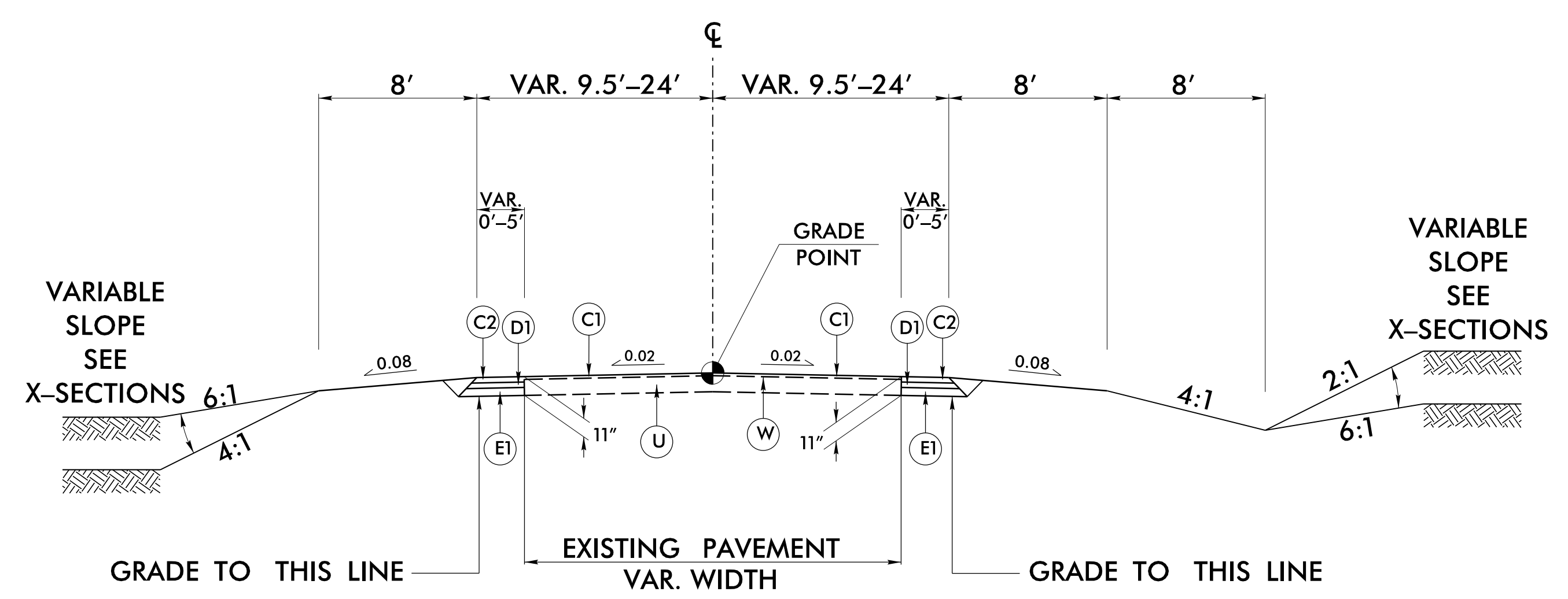

TYPICAL SECTION NO. 6

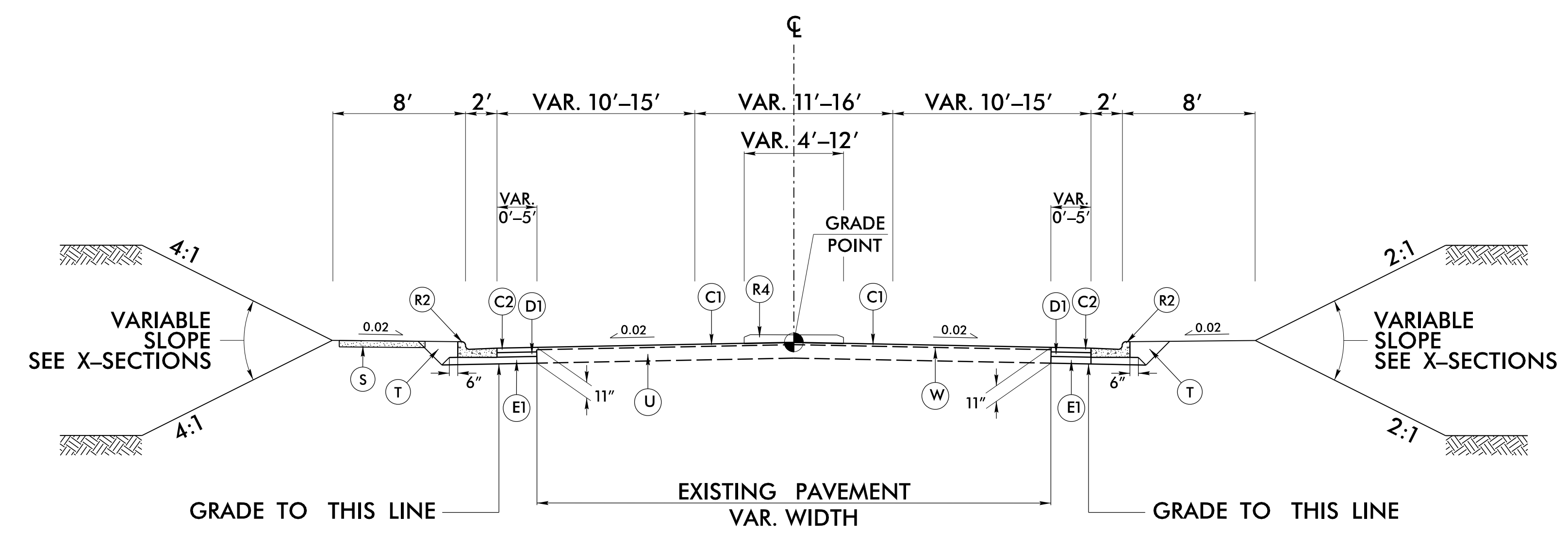

TYPICAL SECTION NO. 7

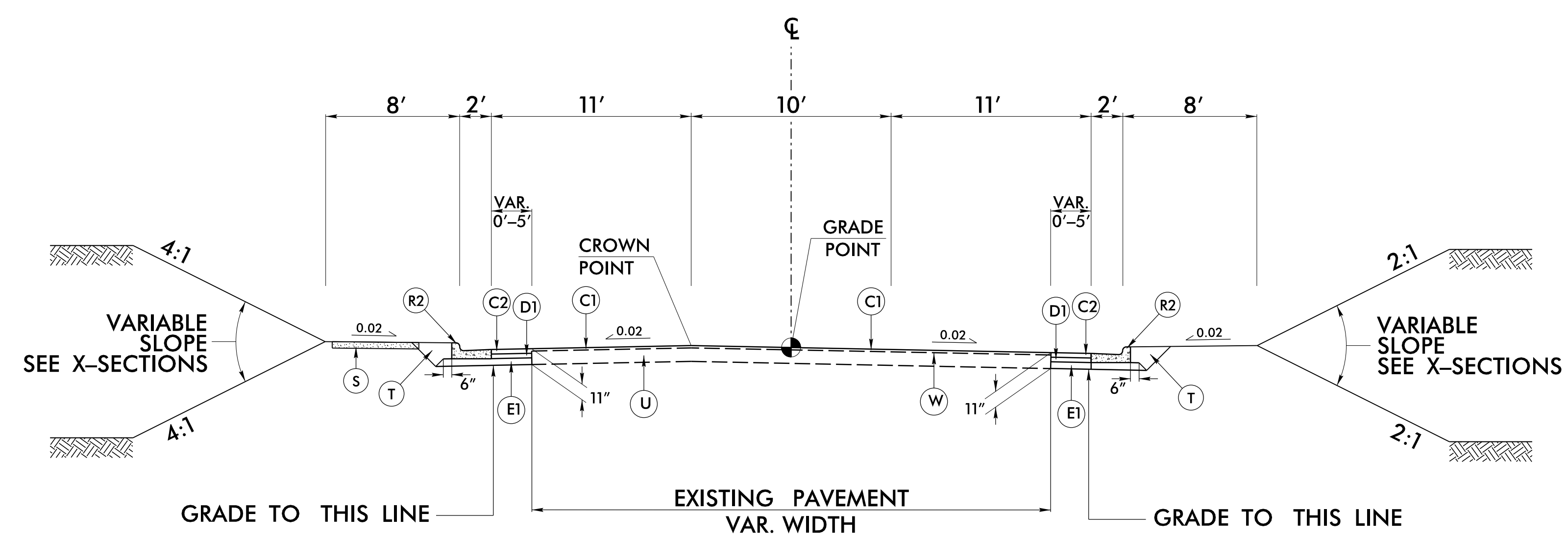

TYPICAL SECTION NO. 8

USE TYPICAL SECTION NO. 6

- Y1- STA 10+75.00 TO STA 12+11.66
- Y2- STA 10+39.50 TO STA 11+75.00
- Y3- STA 13+06.66 TO STA 15+25.00
- Y4- STA 10+25.00 TO STA 12+13.74
- Y4- STA 10+00.00 TO STA 11+34.42
- Y4- STA 12+15.01 TO STA 13+75.00
- Y5- STA 10+39.69 TO STA 11+50.00
- Y6- STA 10+51.94 TO STA 12+00.00
- Y9- STA 10+75 TO STA 11+41.83
- Y9- STA 12+44.85 TO STA 14+85.00
- Y10- STA 10+25.00 TO STA 11+61.58
- Y11A- STA 10+45.47 TO STA 12+25.00
- Y11B- STA 10+00.00 TO STA 11+32.17

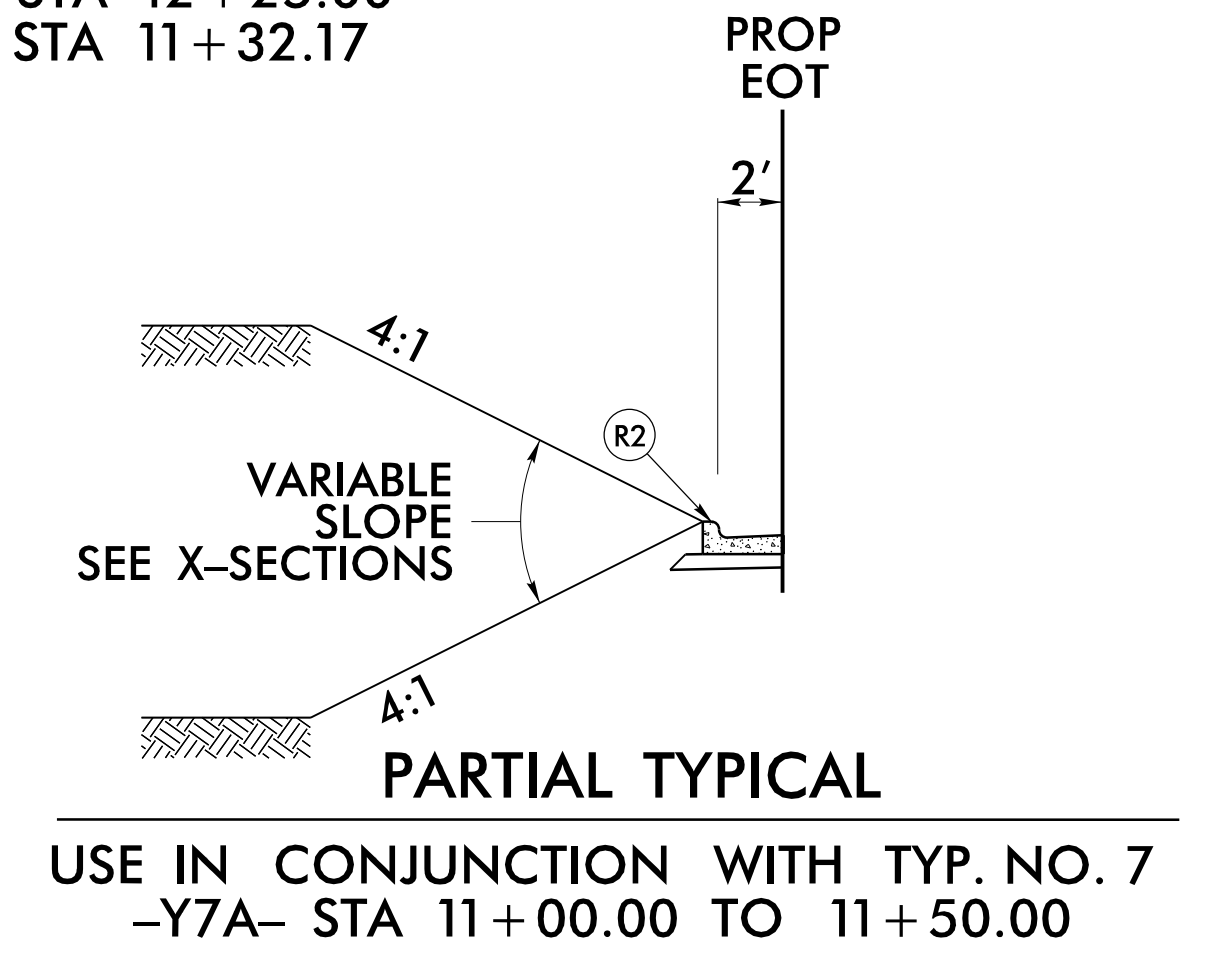

USE IN CONJUNCTION WITH TYP. NO. 7  
-Y7A- STA 11+00.00 TO 11+50.00

USE TYPICAL SECTION NO. 7

- Y7A- STA 10+51.50 TO STA 11+50.00
- Y7B- STA 12+00.00 TO STA 13+03.45
- Y8A- STA 10+46.96 TO STA 12+92.64
- \*SIDEWALK ONLY ON -Y8A-
- \*\*MCI ONLY ON -Y7A- & -Y8A-

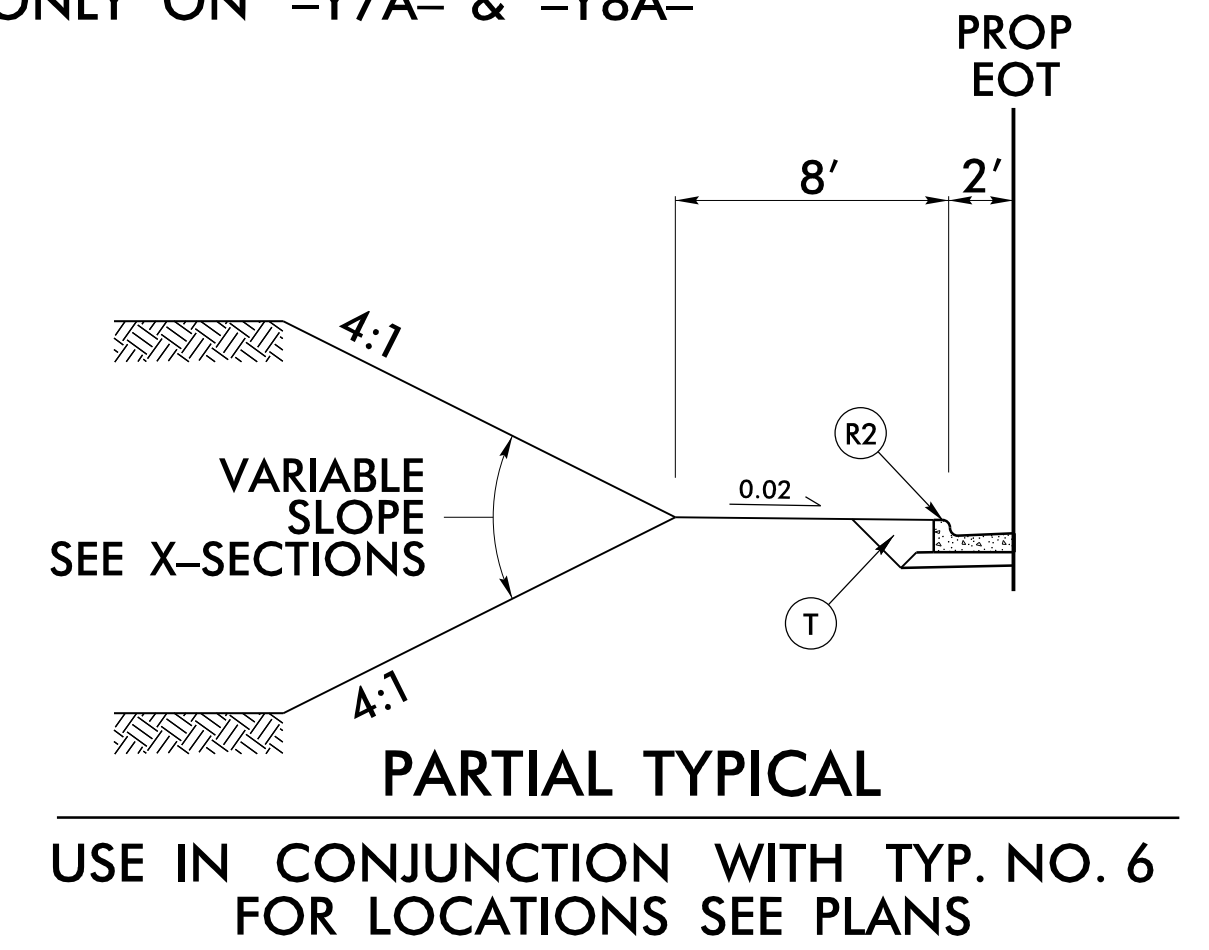

USE TYPICAL SECTION NO. 8  
-Y8B- STA 11+25.00 TO STA 12+42.99

PROJECT REFERENCE NO. U-5824	SHEET NO. 2A-4
ROADWAY DESIGN ENGINEER 9/15/2023 Faith Jahnske	PAVEMENT DESIGN ENGINEER 9/15/2023 Connie K. James
DOCUMENT NOT CONSIDERED FINAL UNLESS ALL SIGNATURES COMPLETED	
Prepared in the Office of:	

14-SEP-2023 15:45  
U-5824\_R06\_Pavement.dgn  
Faith Jahnske

6/2/2019

PAVEMENT SCHEDULE (FINAL PAVEMENT DESIGN)	
C1	1 1/2" S9.5B
C2	3" S9.5B
C3	2.5" S9.5B
C4	VAR. S9.5B
D1	4" I19.0C
D2	VAR. I19.0C
E1	4" B25.0C
E2	5" B25.0C
E3	VAR. B25.0C
K	12" CLASS IV
N	GEOTEXTILE
R1	1'-6" C & G
R2	2'-6" C & G
R3	2'-9" C & G
R4	5" MCI
R5	8"X18" CURB
S	4" SIDEWALK
T	EARTH MATERIAL
U	EXIST. PAVEMENT
V1	INCIDENTAL MILL.
V2	1 1/2" MILLING
W	WEDGING

NOTE: PAVEMENT EDGE SLOPES ARE 1:1 UNLESS SHOWN OTHERWISE.

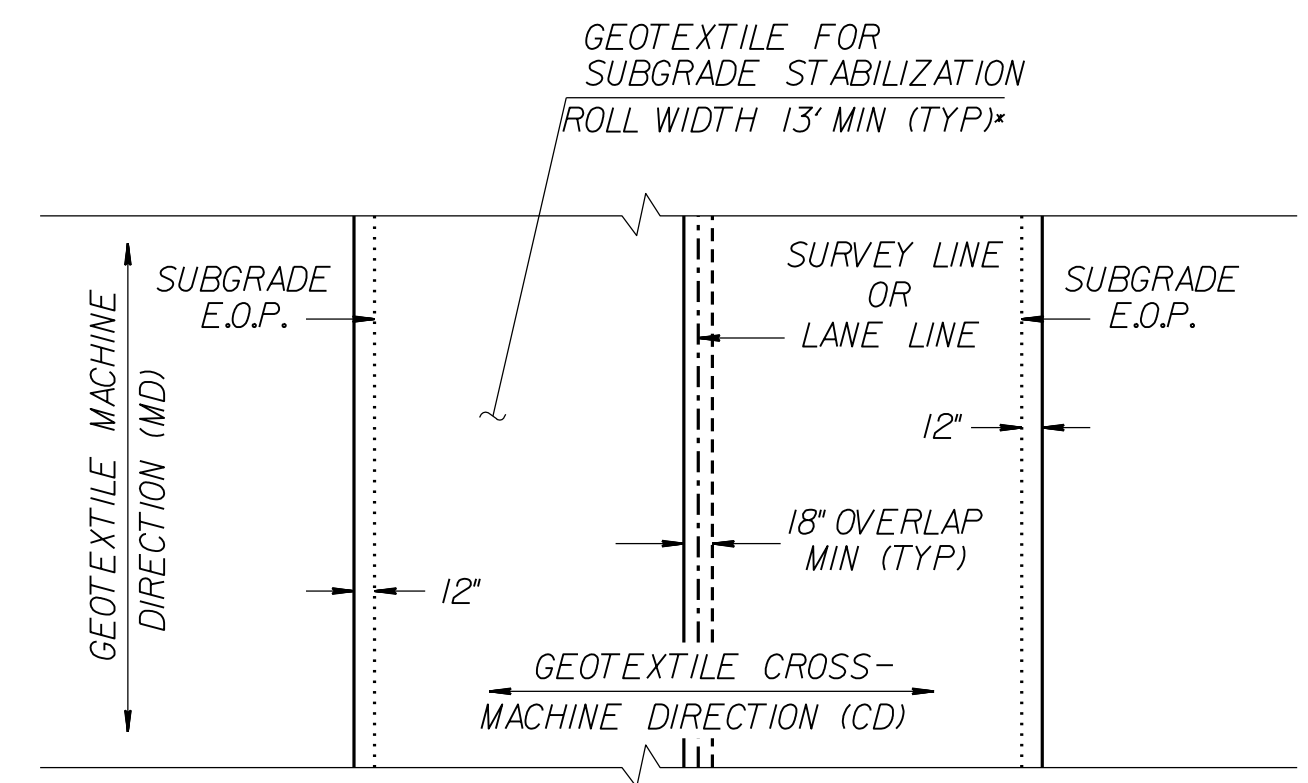

**GEOTEXTILE FOR SUBGRADE STABILIZATION PLACEMENT (PLAN VIEW)**  
(100% COVERAGE REQUIRED)

\*INSTALL GEOTEXTILE FOR SUBGRADE STABILIZATION WITH MINIMUM ROLL WIDTH UNDER ROADWAY EDGES AND SHOULDERS ADJACENT TO FILL SLOPES

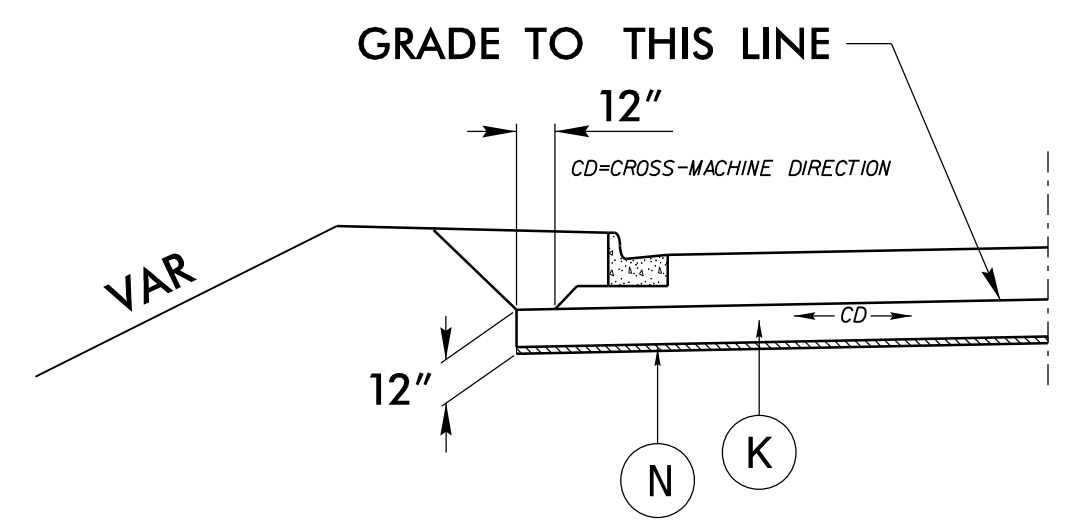

**DETAIL FOR SHALLOW UNDERCUT**

-L- STA 92+75 TO 97+25  
-L- STA 102+75 TO 105+25

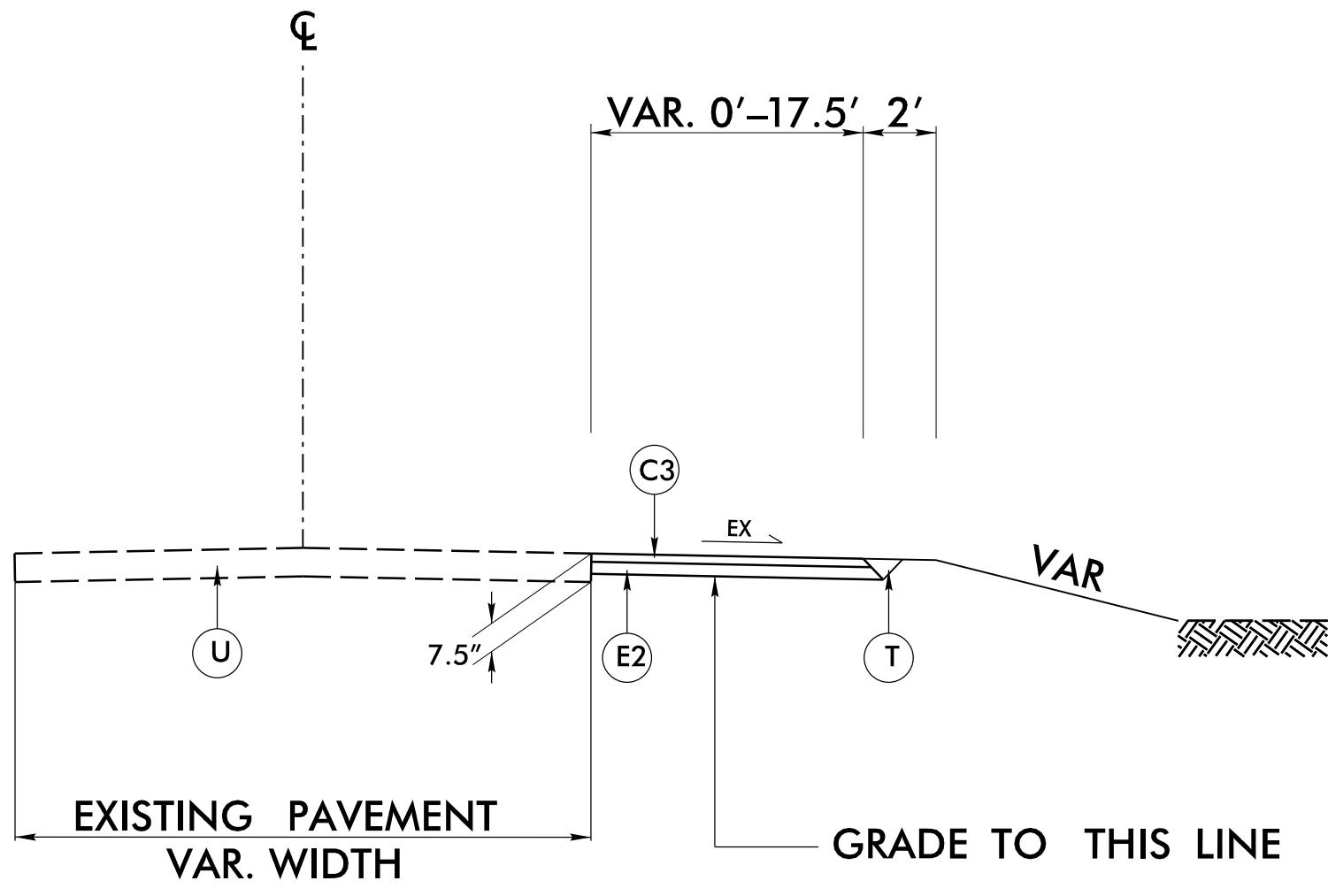

**TYPICAL SECTION NO. 9**

USE TYPICAL SECTION NO. 9

-L- STA 17+10 +/- TO 21+85 +/-  
-L- STA 56+00 +/- TO 63+00 +/-  
-L- STA 66+18 +/- TO 68+27 +/-

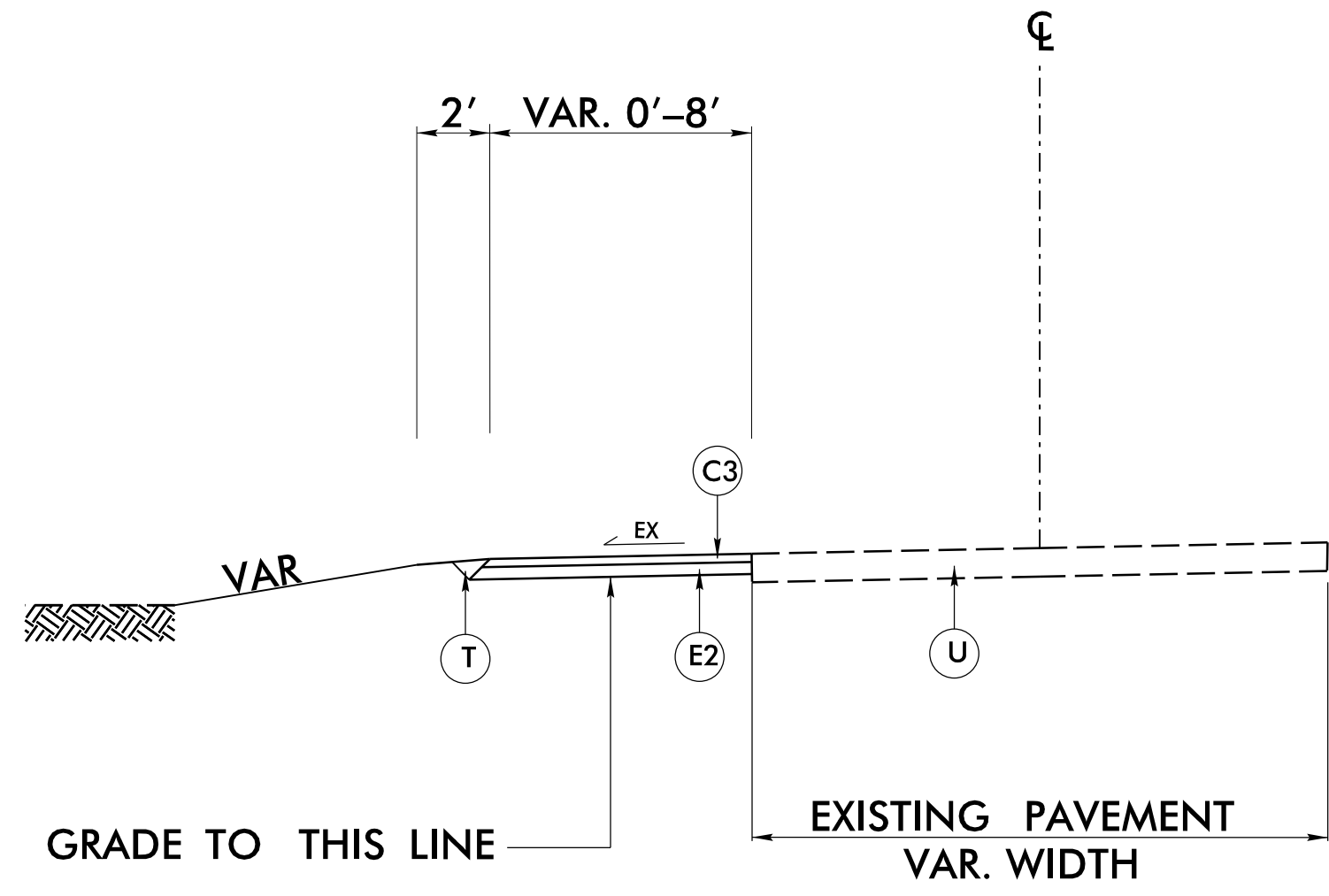

**TYPICAL SECTION NO. 10**

USE TYPICAL SECTION NO. 10

-L- STA 22+50 +/- TO 26+36 +/-

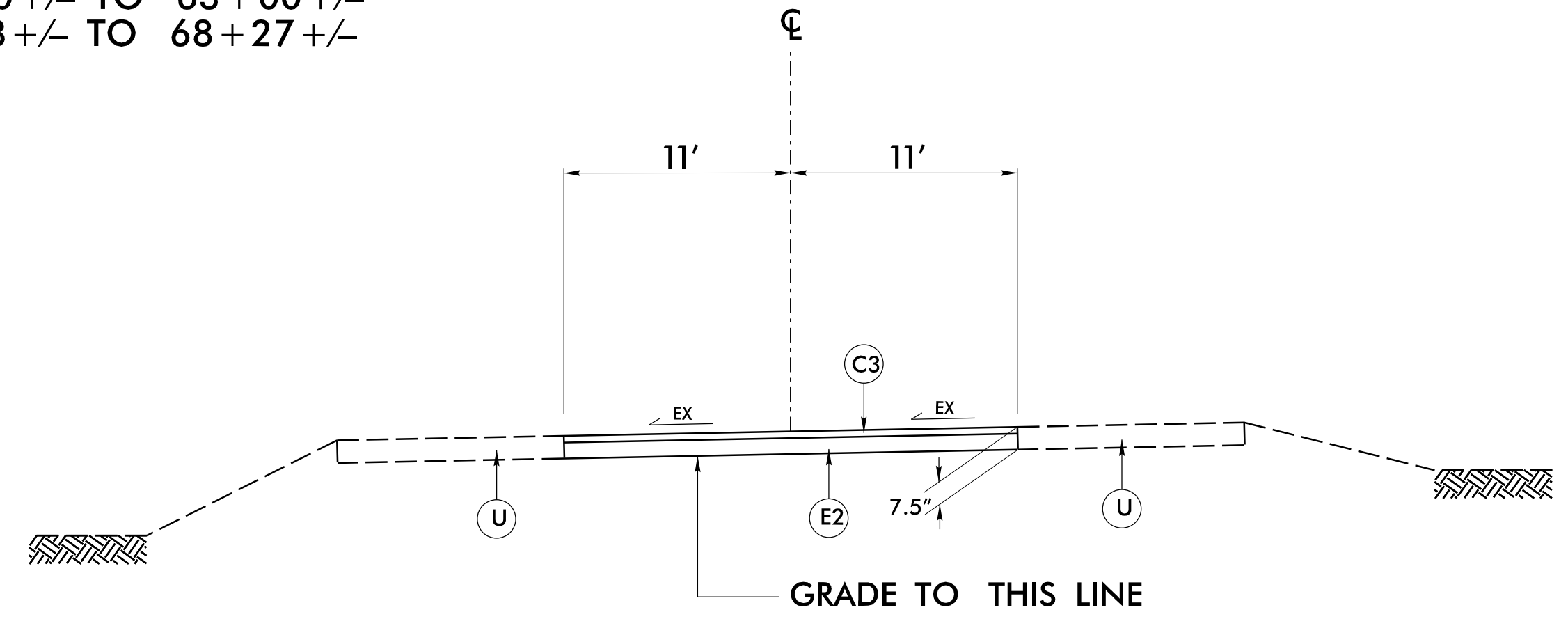

**TYPICAL SECTION NO. 11**

USE TYPICAL SECTION NO. 11

-L- STA 20+35 +/- TO 24+72 +/-

PROJECT REFERENCE NO. <b>U-5824</b>	SHEET NO. <b>2A-5</b>
ROADWAY DESIGN ENGINEER 9/15/2023 <b>Faith Jahnske</b> SEAL 046981 ENGINEER NORTH CAROLINA PROFESSIONAL SEAL	PAVEMENT DESIGN ENGINEER 9/15/2023 <b>Connie K. James</b> SEAL 018969 ENGINEER NORTH CAROLINA PROFESSIONAL SEAL
<b>DOCUMENT NOT CONSIDERED FINAL UNLESS ALL SIGNATURES COMPLETED</b>	
Prepared in the Office of: <b>SUMMIT</b> DESIGN AND ENGINEERING SERVICES	NC FIRM LICENSE No. P-0339 320 Executive Ct. Hillsborough, NC 27278 (919) 732-3883 (919) 732-6676 (FAX)

14-SEP-2023 15:46.dgn  
U-5824\_Roadway Design  
Faith Jahnske



8/17/99

# INTERSECTION DETAIL (-L/-Y1-) & (-L/-Y2-)

PROJECT REFERENCE NO. U-5824	SHEET NO. 2B-1
RW SHEET NO.	
ROADWAY DESIGN ENGINEER 9/15/2023	HYDRAULICS ENGINEER
<b>DOCUMENT NOT CONSIDERED FINAL UNLESS ALL SIGNATURES COMPLETED</b>	
Prepared in the Office of:	

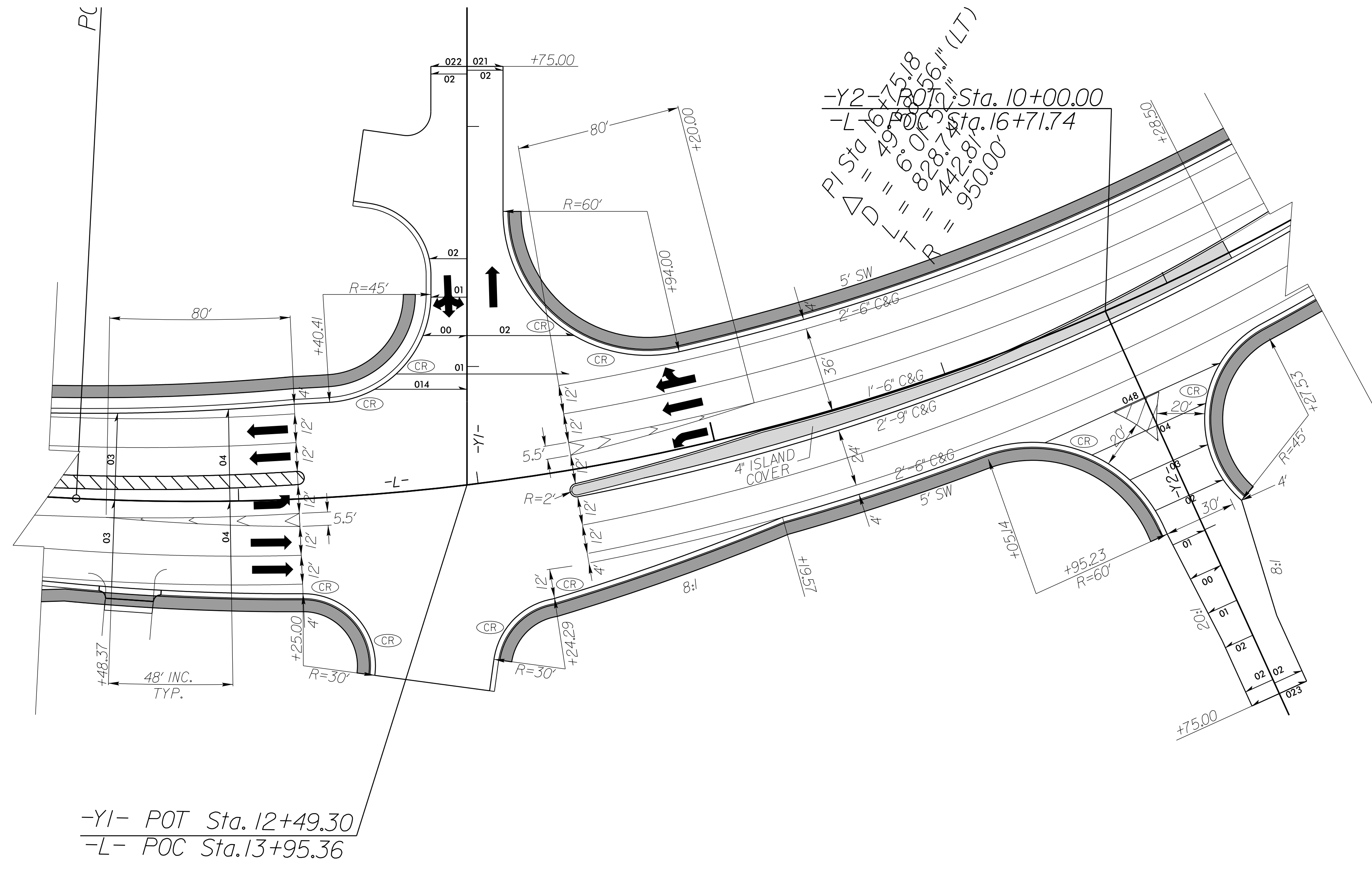
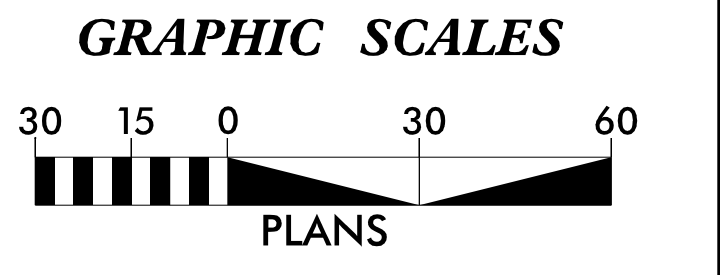
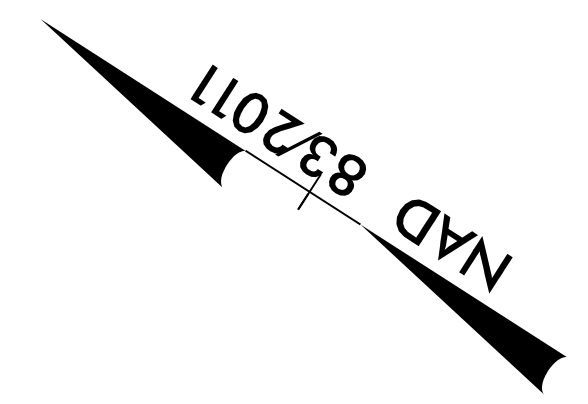

FOR CURB RAMP LOCATIONS  
SEE SHEET PMP-2

FOR PLAN VIEW  
SEE SHEET 4

06-SEP-2023 15:47  
D:\6341\_Roads\2B-1.dgn  
faulb.obbke

### INTERSECTION DETAIL (-L-/Y3-)

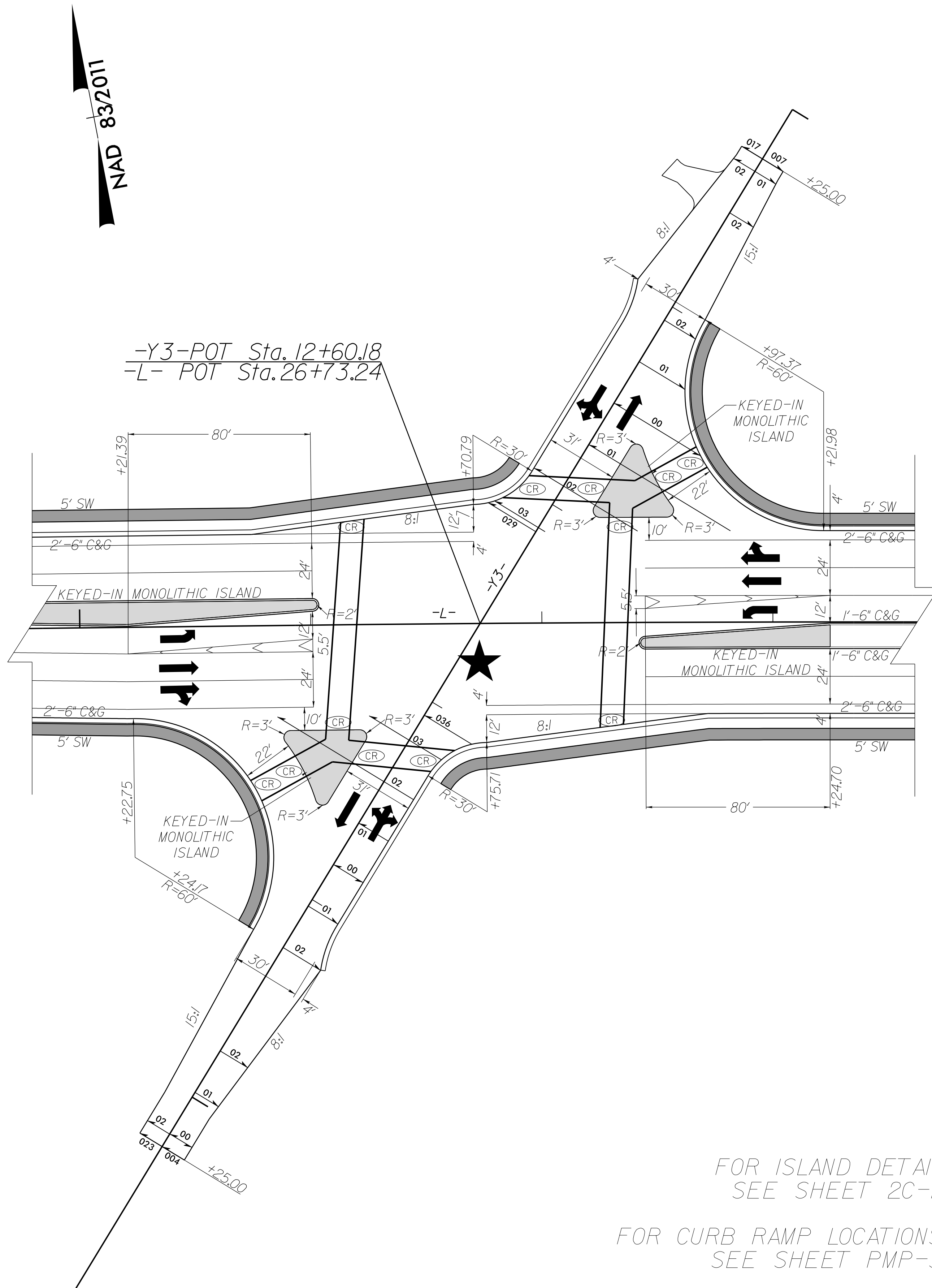

-Y3-POT Sta. 12+60.18  
-L- POT Sta. 26+73.24

FOR ISLAND DETAIL  
SEE SHEET 2C-11

FOR CURB RAMP LOCATIONS  
SEE SHEET PMP-3

FOR PLAN VIEW  
SEE SHEET 5

### INTERSECTION DETAIL (-L-/Y4-)

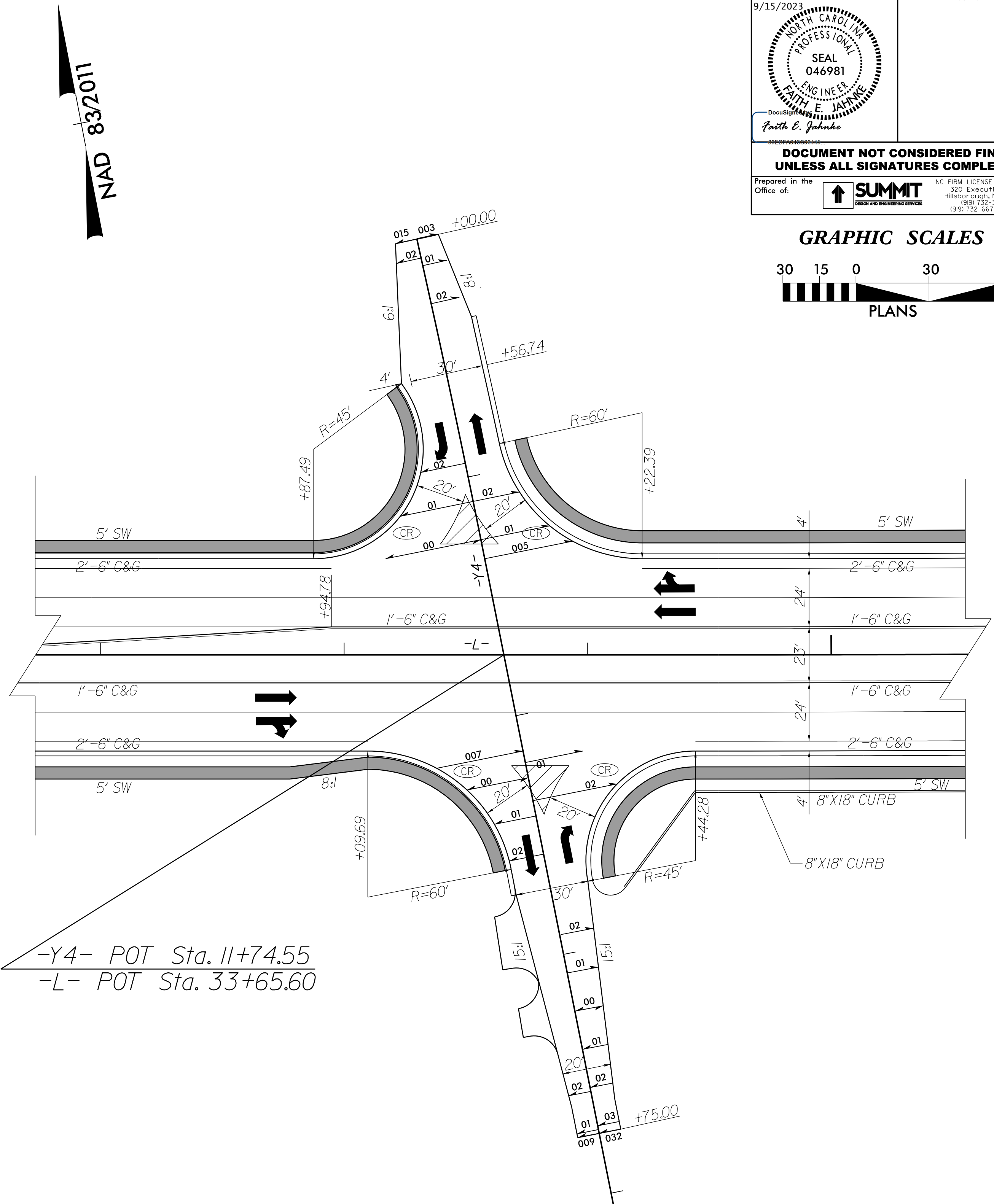

-Y4- POT Sta. 11+74.55  
-L- POT Sta. 33+65.60

FOR CURB RAMP LOCATIONS  
SEE SHEET PMP-3

FOR PLAN VIEW  
SEE SHEET 5

PROJECT REFERENCE NO. <i>U-5824</i>	SHEET NO. <i>2B-2</i>
RW SHEET NO.	
ROADWAY DESIGN ENGINEER 9/15/2023	HYDRAULICS ENGINEER
<b>DOCUMENT NOT CONSIDERED FINAL UNLESS ALL SIGNATURES COMPLETED</b>	
Prepared in the Office of: 	NC FIRM LICENSE NO: P-0339 300 Executive Ct. Hillsborough, NC 27278 (919) 732-3883 (919) 732-6676 (FAX)

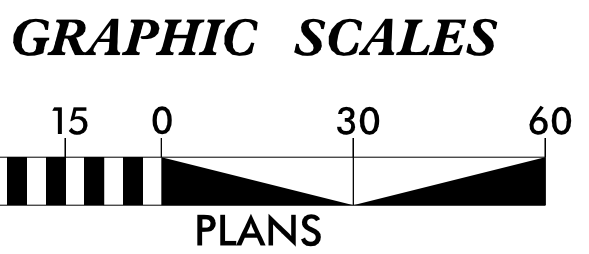

REVISIONS



8.17.19

# INTERSECTION DETAIL (-L/-Y5-)

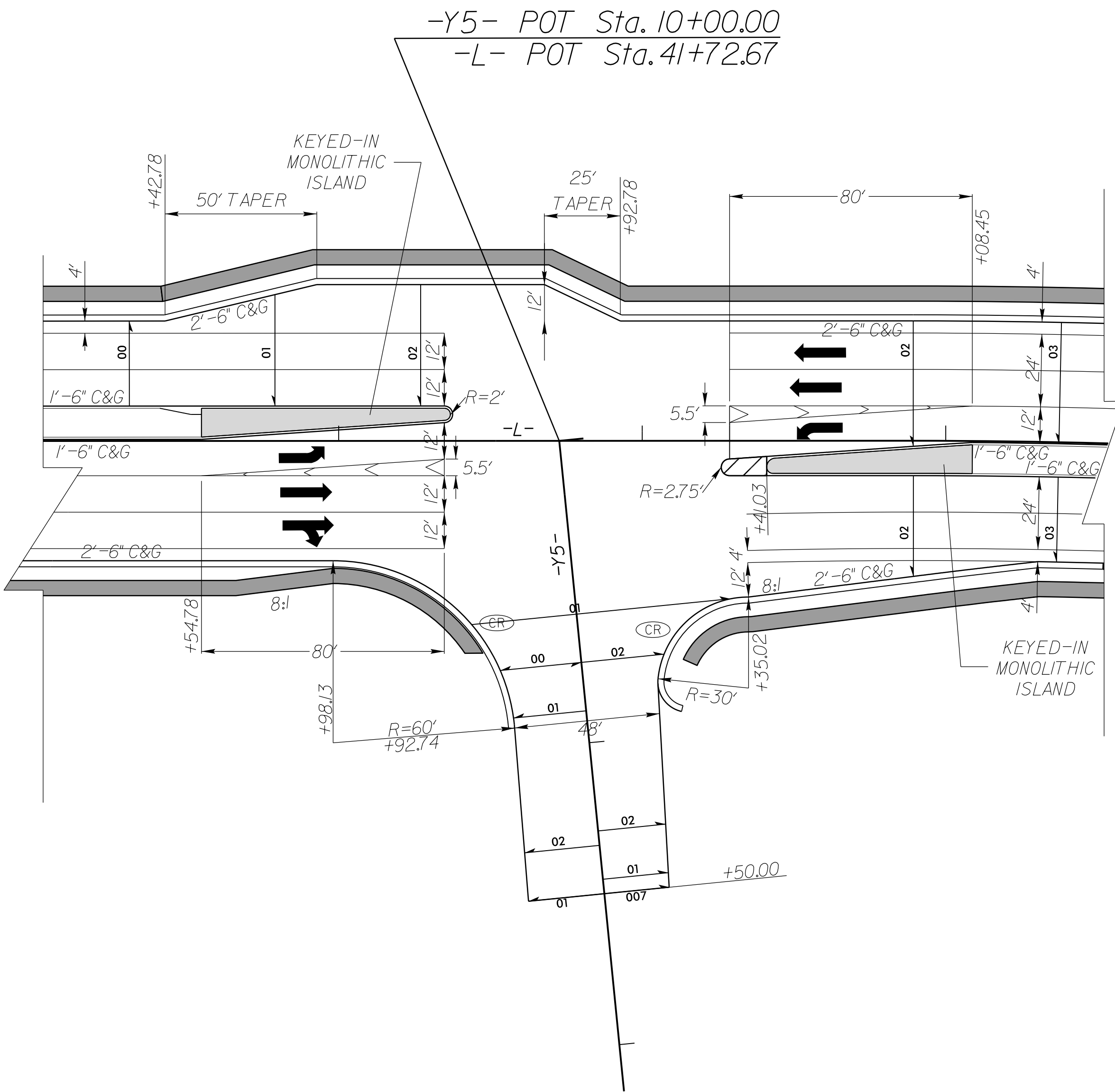
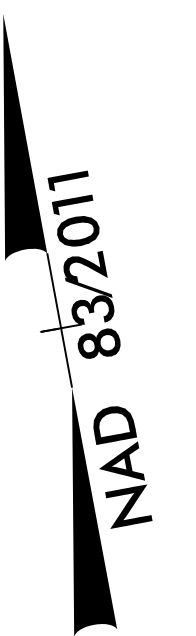

FOR CURB RAMP LOCATIONS  
SEE SHEET PMP-4  
FOR PLAN VIEW  
SEE SHEET 6

# INTERSECTION DETAIL (-L/-Y6-) & (-Y7A/-L/-Y7B-)

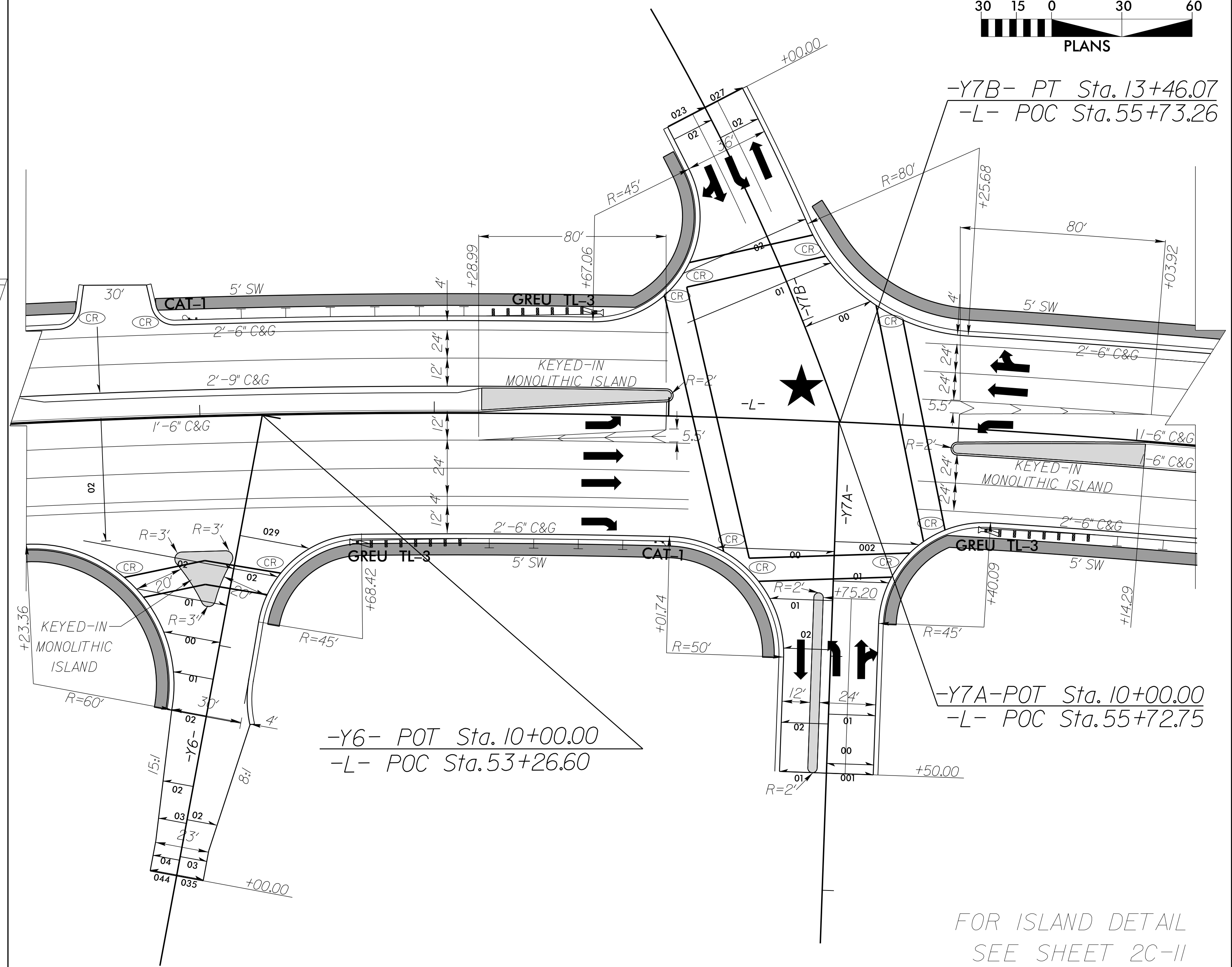
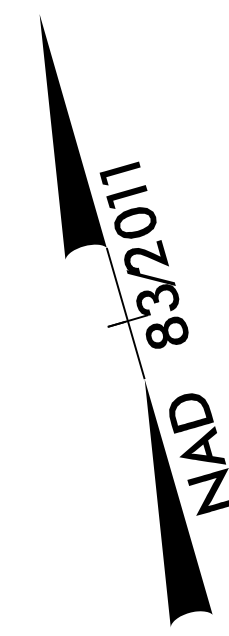

FOR ISLAND DETAIL  
SEE SHEET 2C-II  
FOR CURB RAMP LOCATIONS  
SEE SHEET PMP-5  
FOR PLAN VIEW  
SEE SHEET 7

PROJECT REFERENCE NO. U-5824	SHEET NO. 2B-3
RW SHEET NO.	
ROADWAY DESIGN ENGINEER 9/15/2023	HYDRAULICS ENGINEER
<b>DOCUMENT NOT CONSIDERED FINAL UNLESS ALL SIGNATURES COMPLETED</b>	
Prepared in the Office of:	

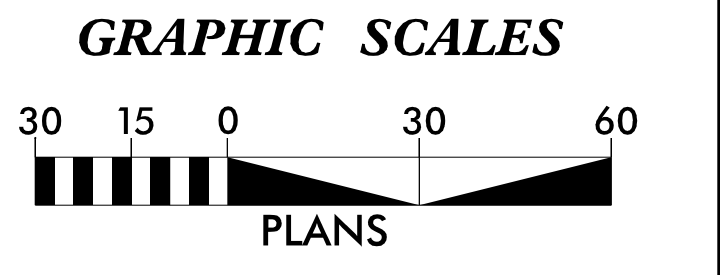

REVISIONS

06-SEP-2023 15:47  
066%1\_Roads-2B-3.dgn  
faub, jankovic

# INTERSECTION DETAIL (-Y8A--L--Y8B-)

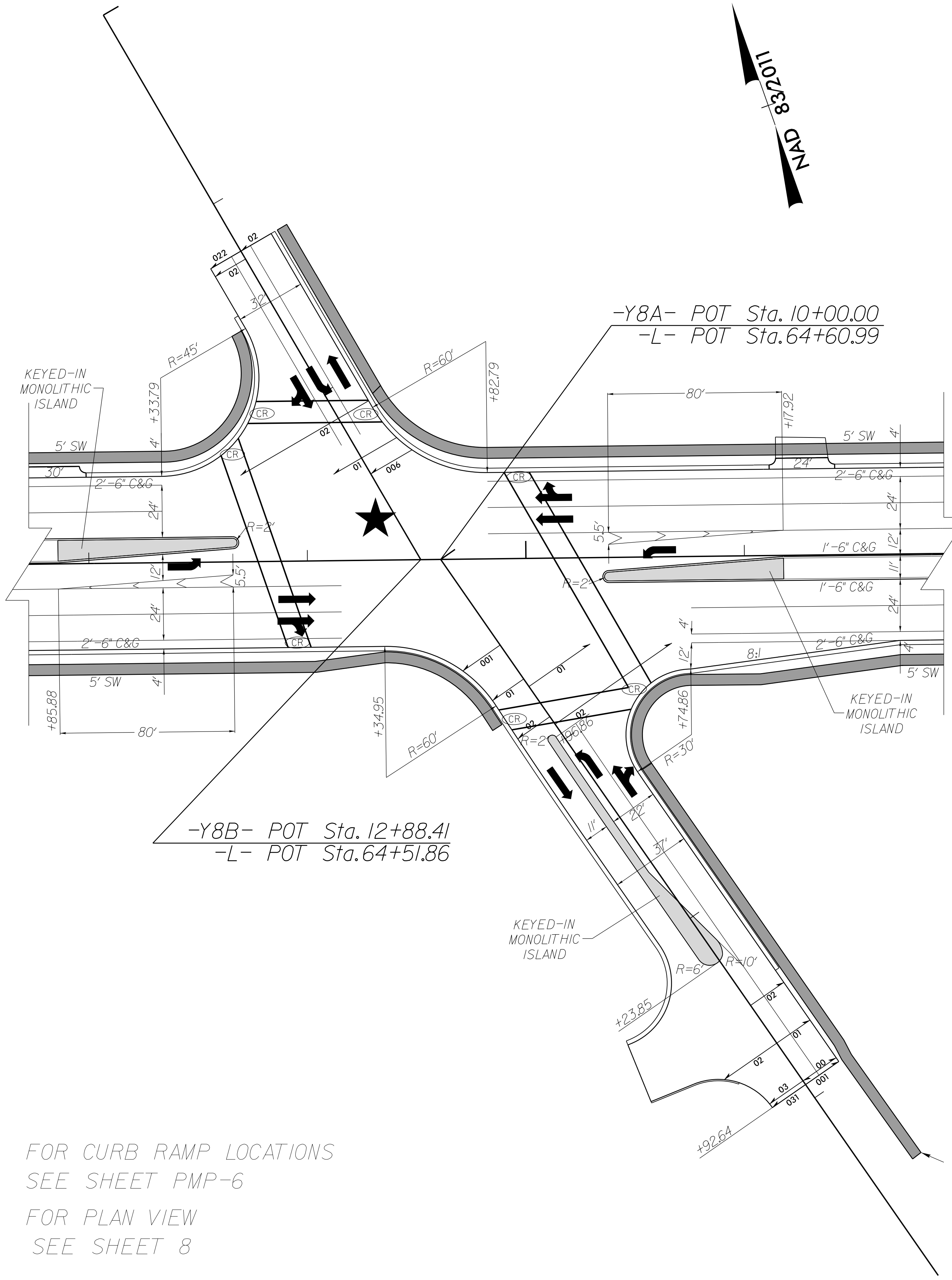

FOR CURB RAMP LOCATIONS  
SEE SHEET PMP-6  
FOR PLAN VIEW  
SEE SHEET 8

# INTERSECTION DETAIL (-L--Y9-)

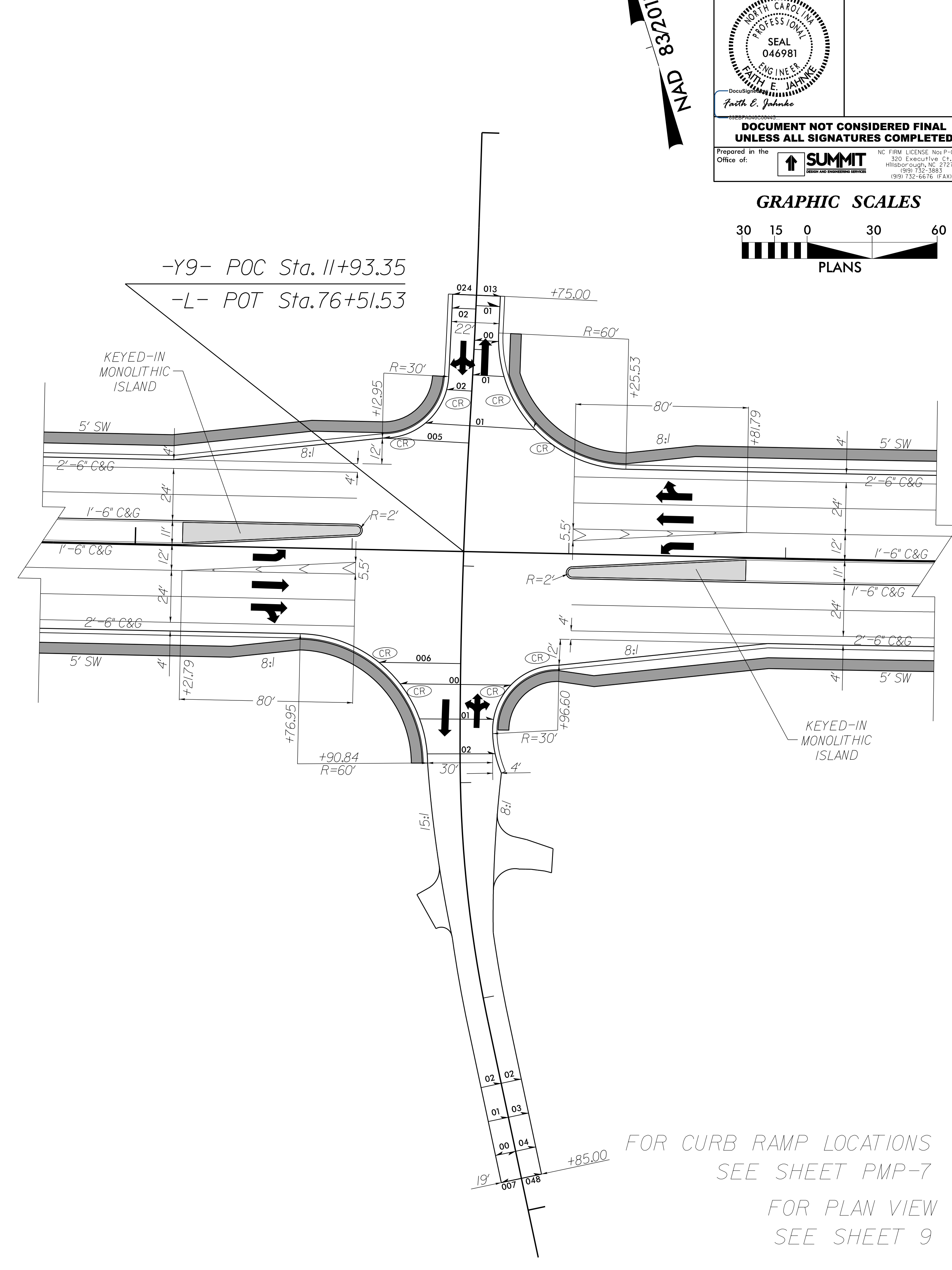

FOR CURB RAMP LOCATIONS  
SEE SHEET PMP-7  
FOR PLAN VIEW  
SEE SHEET 9

PROJECT REFERENCE NO. U-5824	SHEET NO. 2B-4
RW SHEET NO.	
ROADWAY DESIGN ENGINEER 9/15/2023	HYDRAULICS ENGINEER
<b>DOCUMENT NOT CONSIDERED FINAL UNLESS ALL SIGNATURES COMPLETED</b>	
Prepared in the Office of:	

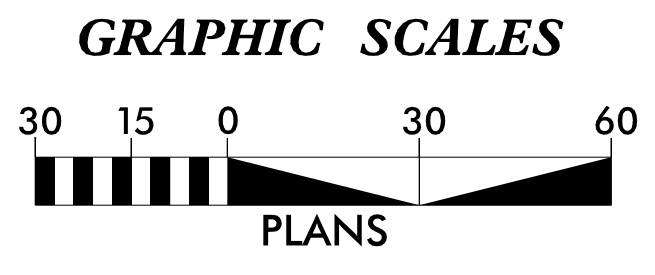

REVISIONS



# INTERSECTION DETAIL (-L/-Y10-)

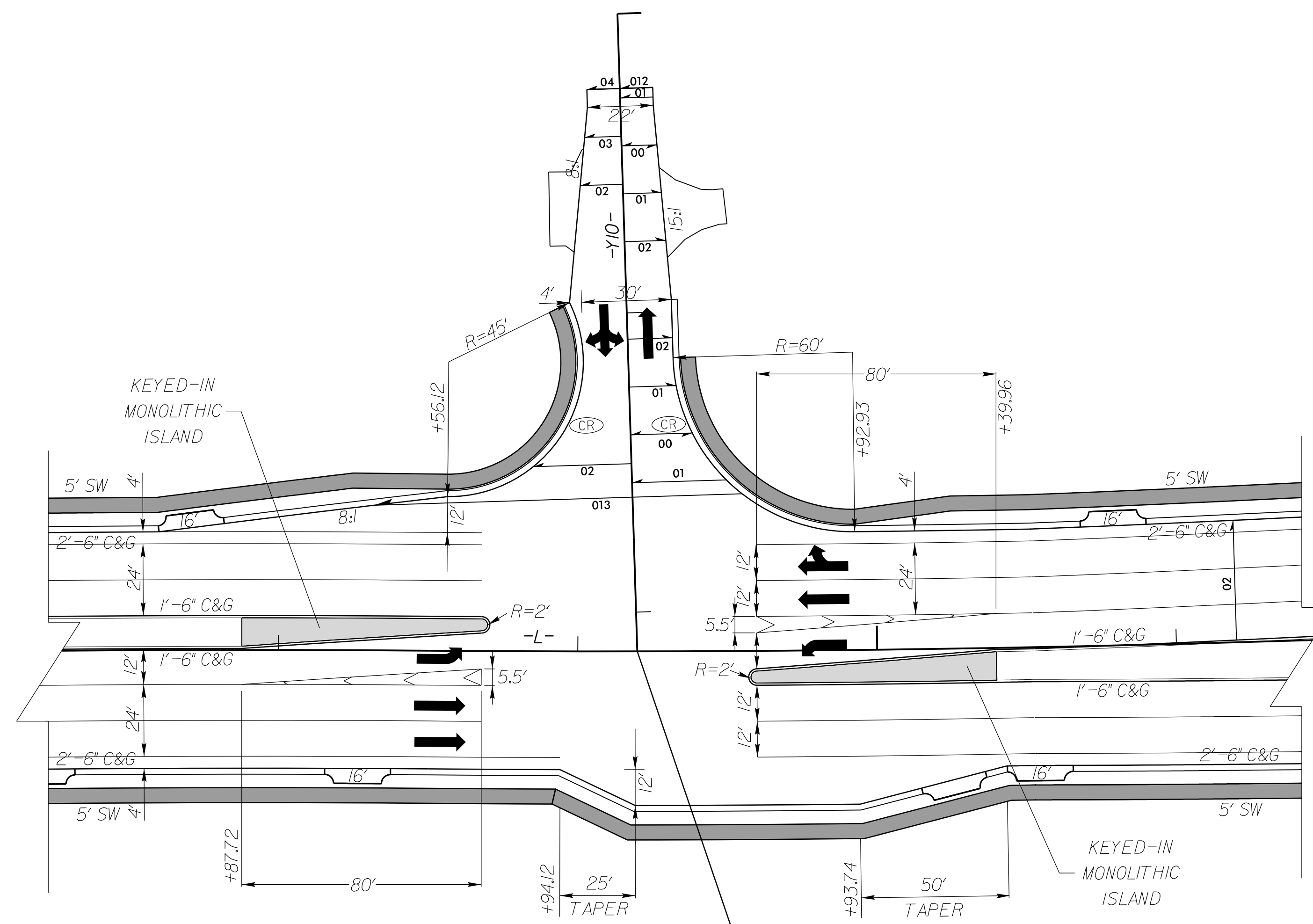
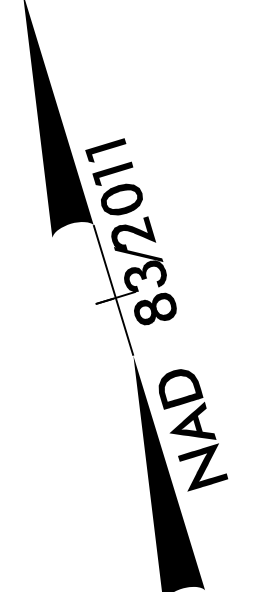

-Y10- POT Sta. 12+13.11  
-L- POT Sta. 89+19.86

FOR CURB RAMP LOCATIONS  
SEE SHEET PMP-8  
FOR PLAN VIEW  
SEE SHEET 10

# INTERSECTION DETAIL (-L/-Y11A-) & (-L/-Y11B-)

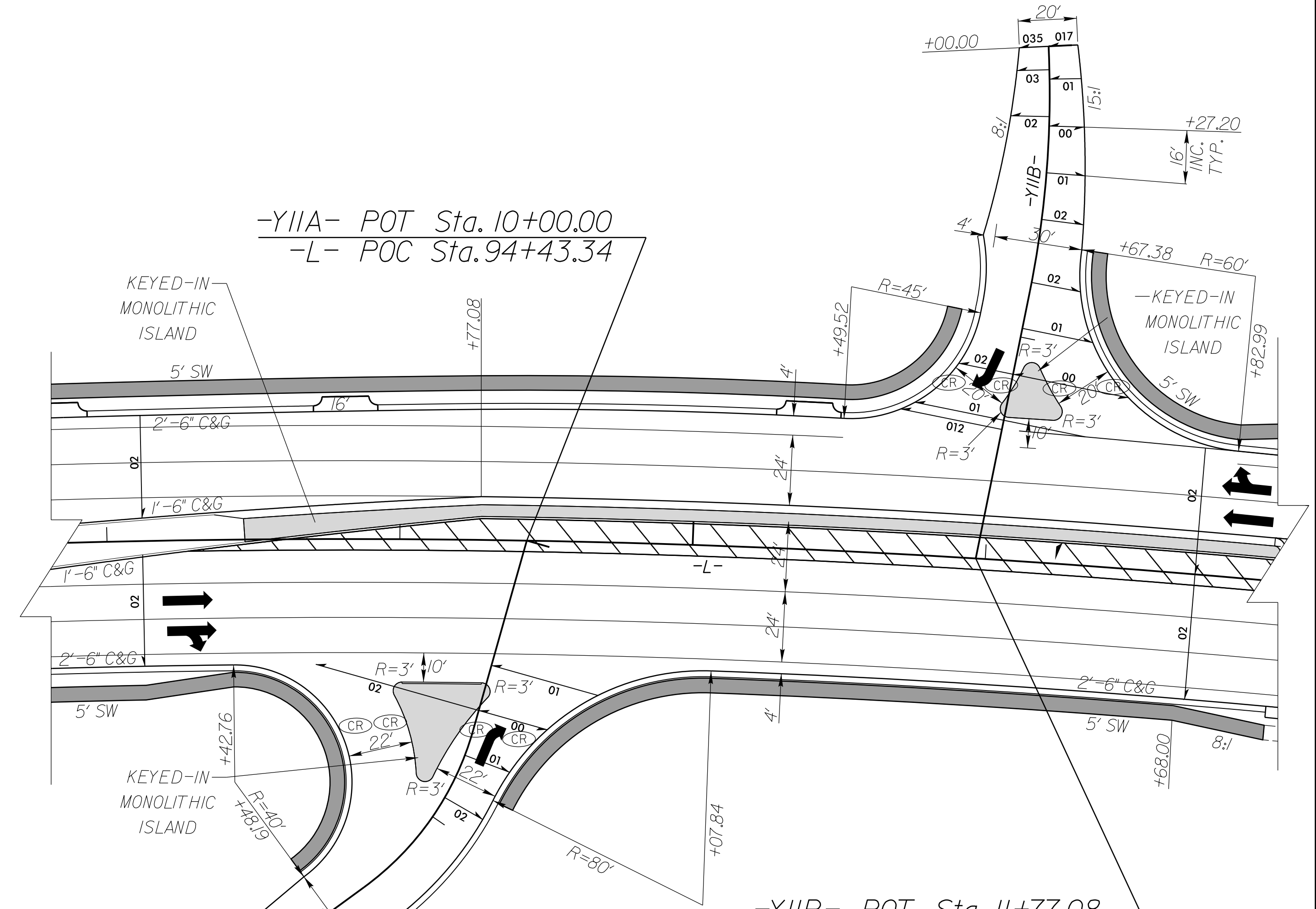
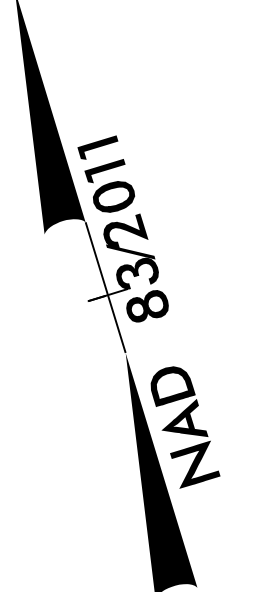

-Y11A- POT Sta. 10+00.00  
-L- POC Sta. 94+43.34

-Y11B- POT Sta. 11+77.08  
-L- POC Sta. 95+96.76

FOR ISLAND DETAIL  
SEE SHEET 2C-11  
FOR CURB RAMP LOCATIONS  
SEE SHEET PMP-8  
FOR PLAN VIEW  
SEE SHEET 10

PROJECT REFERENCE NO. U-5824	SHEET NO. 2B-5
RW SHEET NO.	
ROADWAY DESIGN ENGINEER 9/15/2023	HYDRAULICS ENGINEER
<b>DOCUMENT NOT CONSIDERED FINAL UNLESS ALL SIGNATURES COMPLETED</b>	
Prepared in the Office of:	

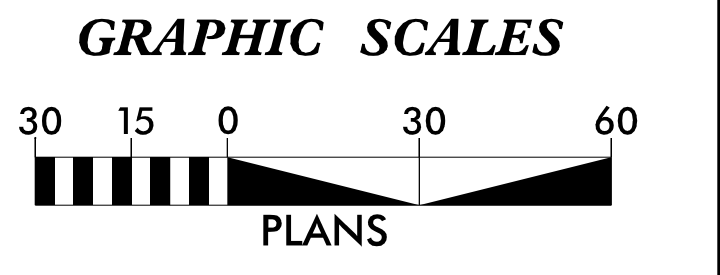

REVISIONS

# INTERSECTION DETAIL (-L-/Y12\_PR-)

PROJECT REFERENCE NO. <i>U-5824</i>	SHEET NO. <i>2B-6</i>
RW SHEET NO.	
ROADWAY DESIGN ENGINEER 9/15/2023	HYDRAULICS ENGINEER
<b>DOCUMENT NOT CONSIDERED FINAL UNLESS ALL SIGNATURES COMPLETED</b>	
Prepared in the Office of:	

NC FIRM LICENSE No: P-0339  
 300 Executive Ct.  
 Hillsborough, NC 27278  
 (919) 732-3883  
 (919) 732-6676 (FAX)

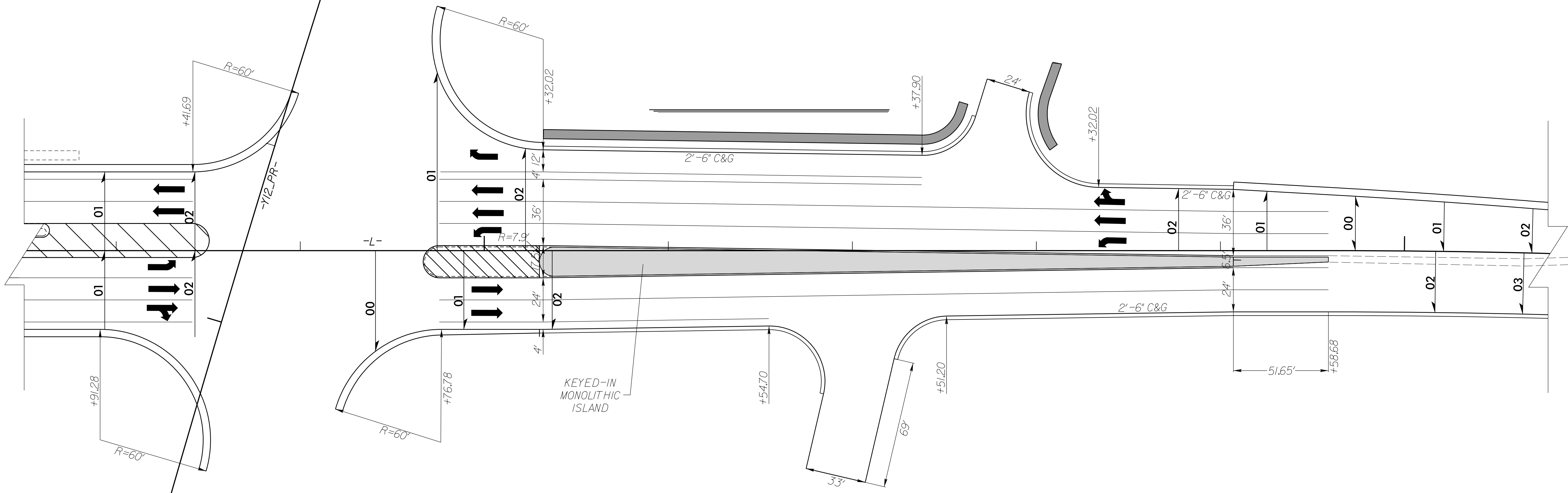
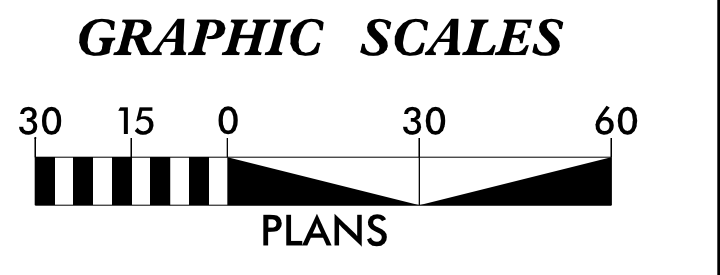
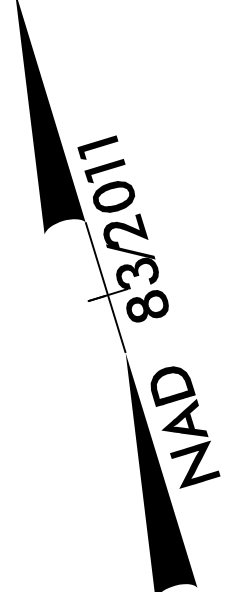

FOR PLAN VIEW  
SEE SHEET II



# TEMPORARY ALIGNMENT 1 DETAIL

FOR TRAFFIC CONTROL  
DETAILS SEE TMP PLANS.  
FOR PROPOSED DRAINAGE, ROADWAY  
FEATURES, AND RIGHT OF WAY  
SEE PSH-4.

PROJECT REFERENCE NO. <b>U-5824</b>	SHEET NO. <b>2B-7</b>
RW SHEET NO.	
ROADWAY DESIGN ENGINEER 9/15/2023	HYDRAULICS ENGINEER
<b>DOCUMENT NOT CONSIDERED FINAL UNLESS ALL SIGNATURES COMPLETED</b>	
Prepared in the Office of:	



**-TEMPI-**  
 PI Sta 17+12.40  
 $\Delta = 49^\circ 58' 56.1''$  (LT)  
 $D = 6^\circ 21' 58.3''$   
 $L = 785.12'$   
 $T = 419.51'$   
 $R = 900.00'$   
 SE = EXIST.  
 DS = 35 MPH

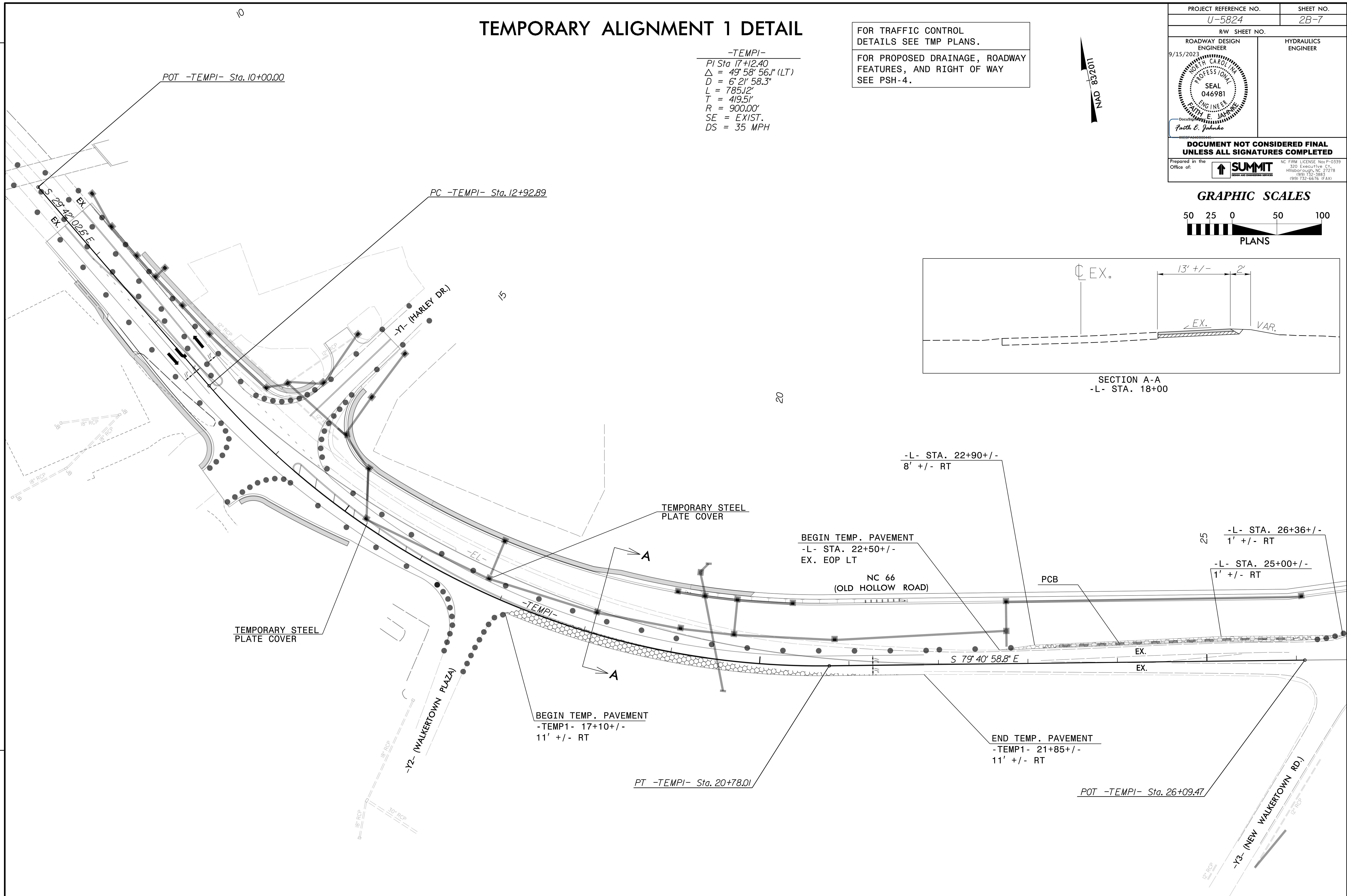
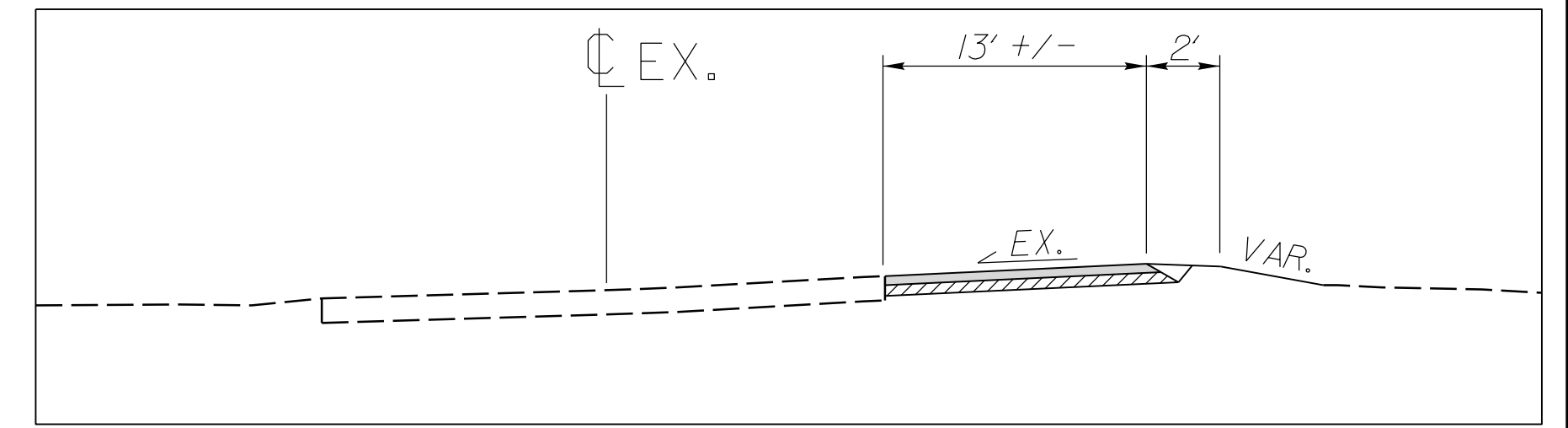
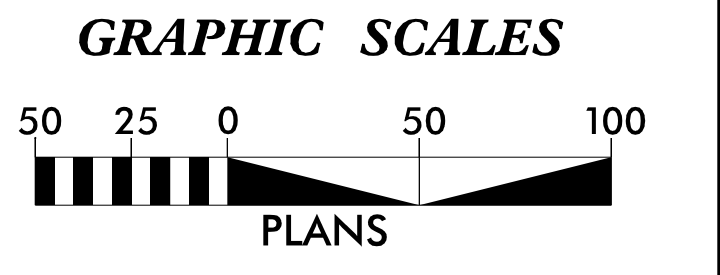

TEMPORARY PAVEMENT

# TEMPORARY ALIGNMENT 2 DETAIL

FOR TRAFFIC CONTROL DETAILS  
SEE TMP PLANS.

FOR PROPOSED DRAINAGE, ROADWAY  
FEATURES, AND RIGHT OF WAY  
SEE PSH 5 & 6.

-TEMP2-  
 PI Sta 18+75.83  
 $\Delta = 11^{\circ} 04' 49.8" (RT)$   
 $D = 1^{\circ} 32' 09.9"$   
 $L = 721.35'$   
 $T = 361.80'$   
 $R = 3,730.00'$



PROJECT REFERENCE NO. <i>U-5824</i>	SHEET NO. <i>2B-8</i>
RW SHEET NO.	
ROADWAY DESIGN ENGINEER 9/15/2023  Faith E. Jankovic	HYDRAULICS ENGINEER
<b>DOCUMENT NOT CONSIDERED FINAL UNLESS ALL SIGNATURES COMPLETED</b>	
Prepared in the Office of:  SUMMIT	NC FIRM LICENSE No: P-0339 300 Executive Ct. Hillsborough, NC 27278 (919) 732-3883 (919) 732-6676 (FAX)

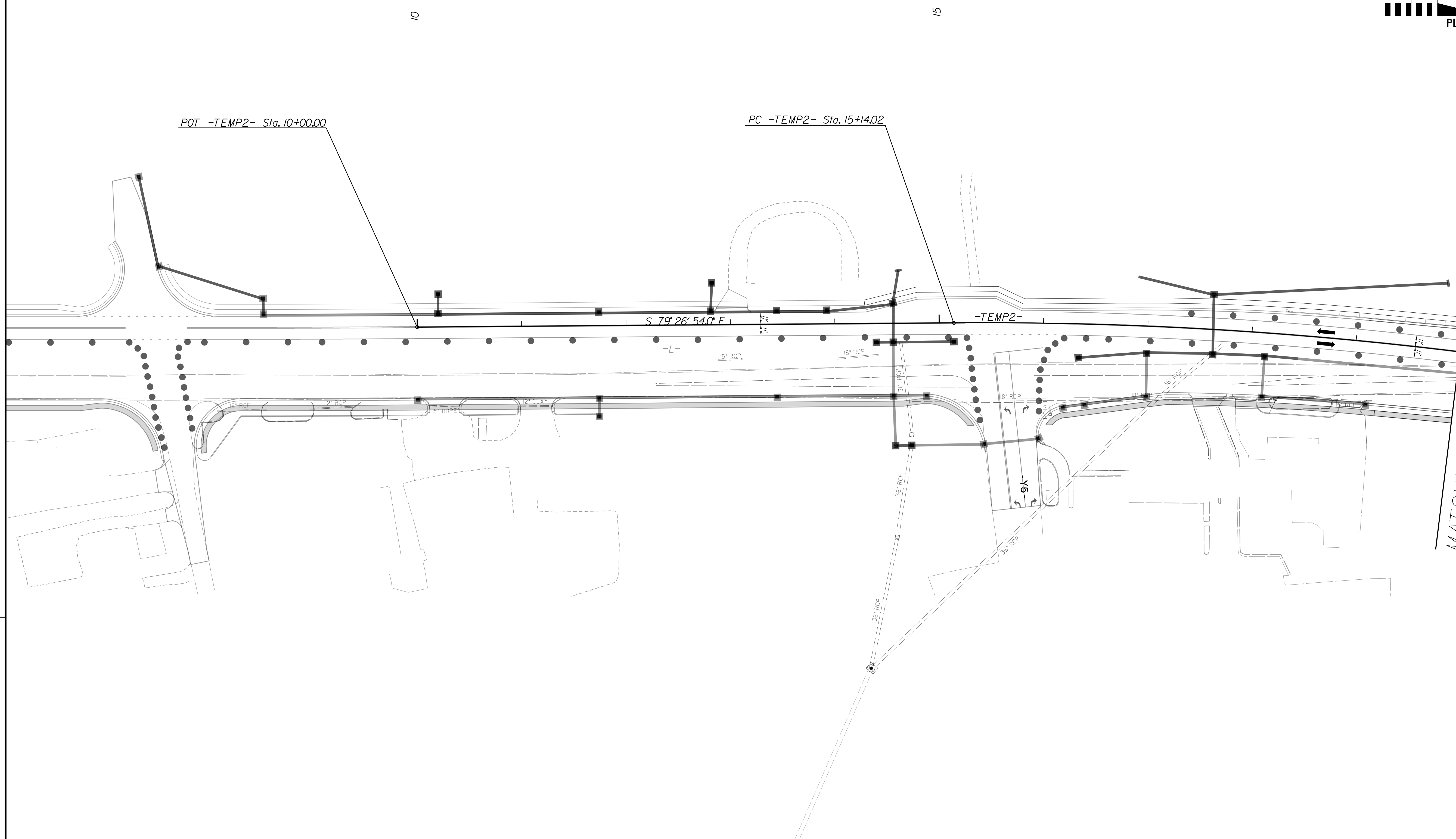
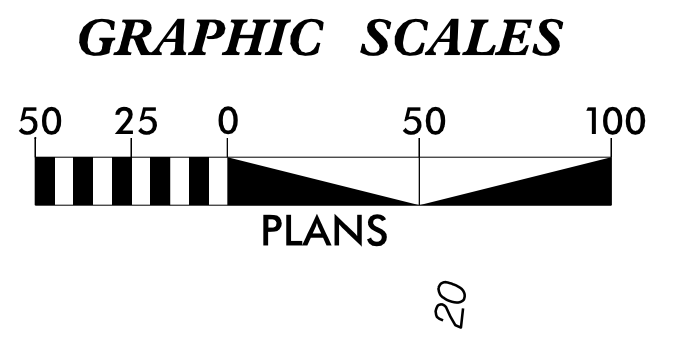

MATCHLINE - TEMP2 - STA. 20+00.00  
(SEE SHEET 2B-9)



# TEMPORARY ALIGNMENT 2 DETAIL

FOR TRAFFIC CONTROL  
DETAILS SEE TMP PLANS.  
  
FOR PROPOSED DRAINAGE, ROADWAY  
FEATURES, AND RIGHT OF WAY  
SEE PSH 6 & 7.



PROJECT REFERENCE NO. <b>U-5824</b>	SHEET NO. <b>2B-9</b>
RW SHEET NO.	
ROADWAY DESIGN ENGINEER 9/15/2023	HYDRAULICS ENGINEER
<b>DOCUMENT NOT CONSIDERED FINAL UNLESS ALL SIGNATURES COMPLETED</b>	
Prepared in the Office of:	

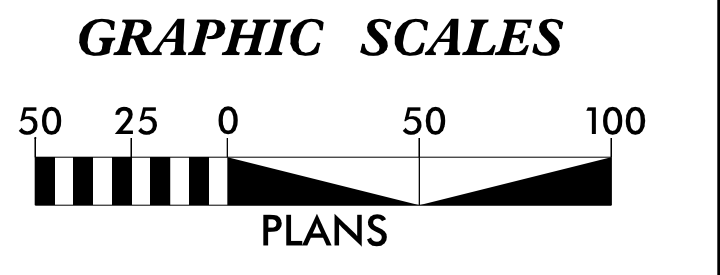

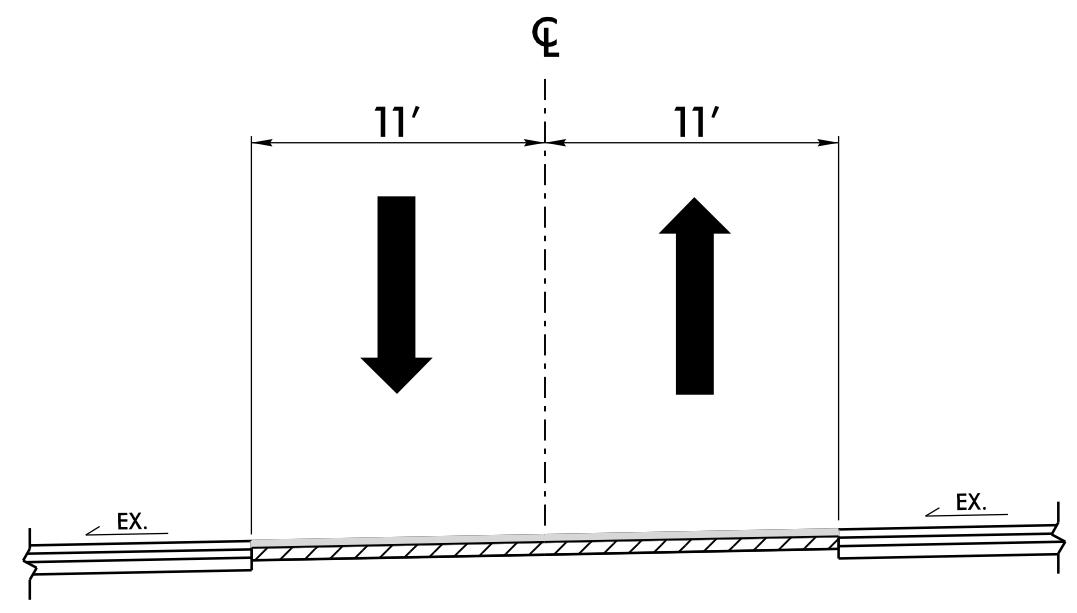
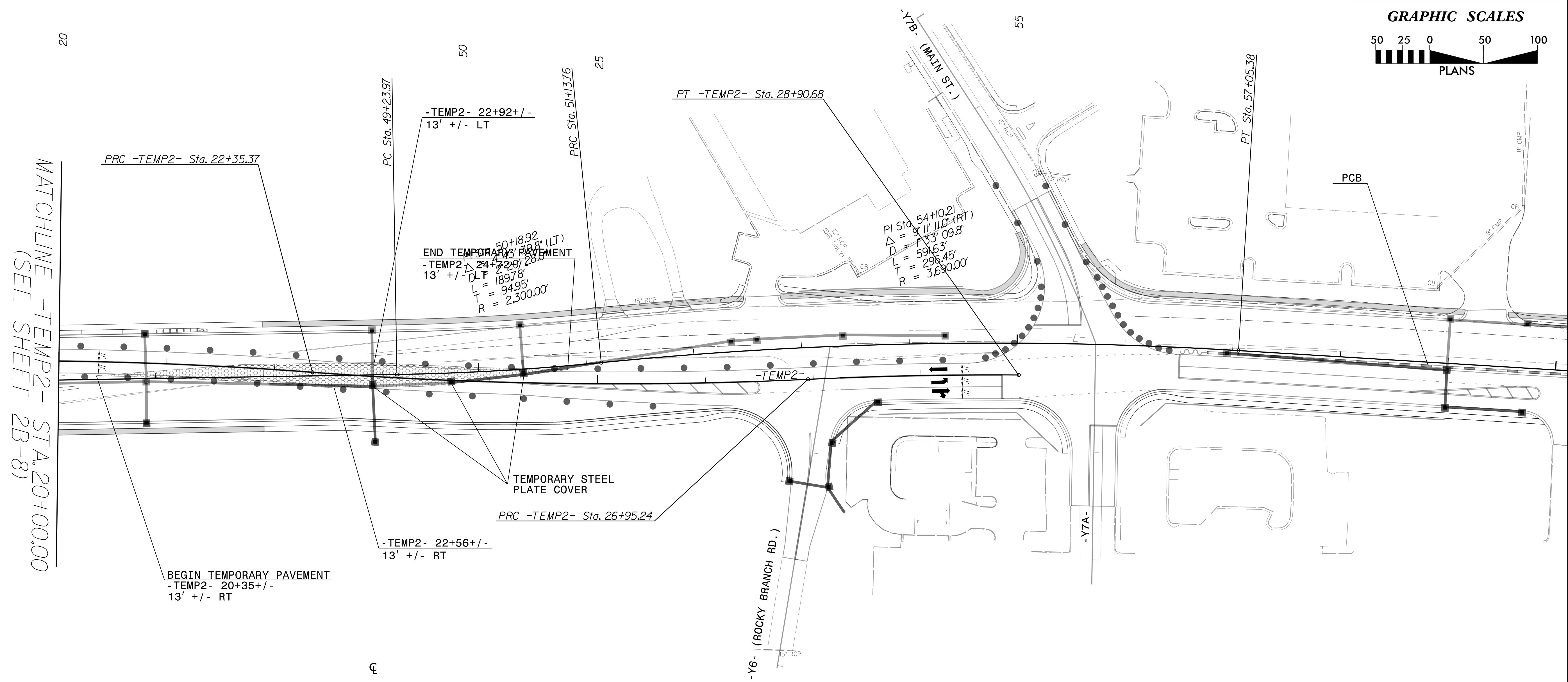

-TEMP2-		
PI Sta 18+75.83	PI Sta 24+65.60	PI Sta 27+92.98
$\Delta = 11^{\circ}04'49.8''$ (RT)	$\Delta = 7^{\circ}03'50.1''$ (LT)	$\Delta = 3^{\circ}03'32.7''$ (RT)
D = 1'32'09.9"	D = 1'32'09.9"	D = 1'33'54.9"
L = 721.35'	L = 459.87'	L = 195.44'
T = 361.80'	T = 230.22'	T = 97.74'
R = 3,730.00'	R = 3,730.00'	R = 3,660.50'



TEMPORARY PAVEMENT

# TEMPORARY ALIGNMENT 3 DETAIL

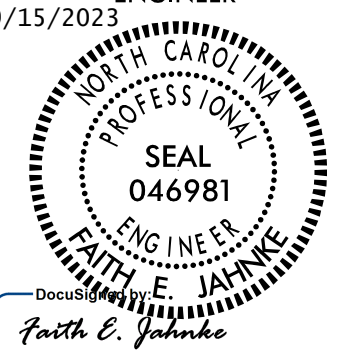
FOR TRAFFIC CONTROL  
DETAILS SEE SHEET TMP PLANS.  
FOR PROPOSED DRAINAGE, ROADWAY  
FEATURES, AND RIGHT OF WAY  
SEE PSH 8 & 9.

PROJECT REFERENCE NO. <i>U-5824</i>	SHEET NO. <i>2B-10</i>
RW SHEET NO.	
ROADWAY DESIGN ENGINEER 9/15/2023	HYDRAULICS ENGINEER
	
<b>DOCUMENT NOT CONSIDERED FINAL UNLESS ALL SIGNATURES COMPLETED</b>	
Prepared in the Office of:	

-TEMP3-		
PI Sta. 14+92.13 $\Delta = 5^{\circ} 47' 49.2"$ (LT) $D = 1^{\circ} 32' 09.9"$ $L = 377.39'$ $T = 188.86'$ $R = 3,730.00'$	PI Sta. 18+51.63 $\Delta = 5^{\circ} 14' 55.9"$ (RT) $D = 1^{\circ} 32' 09.9"$ $L = 341.70'$ $T = 170.97'$ $R = 3,730.00'$	PI Sta. 20+78.61 $\Delta = 1^{\circ} 41' 13.3"$ (LT) $D = 1^{\circ} 29' 59.6"$ $L = 112.48'$ $T = 56.24'$ $R = 3,820.00'$

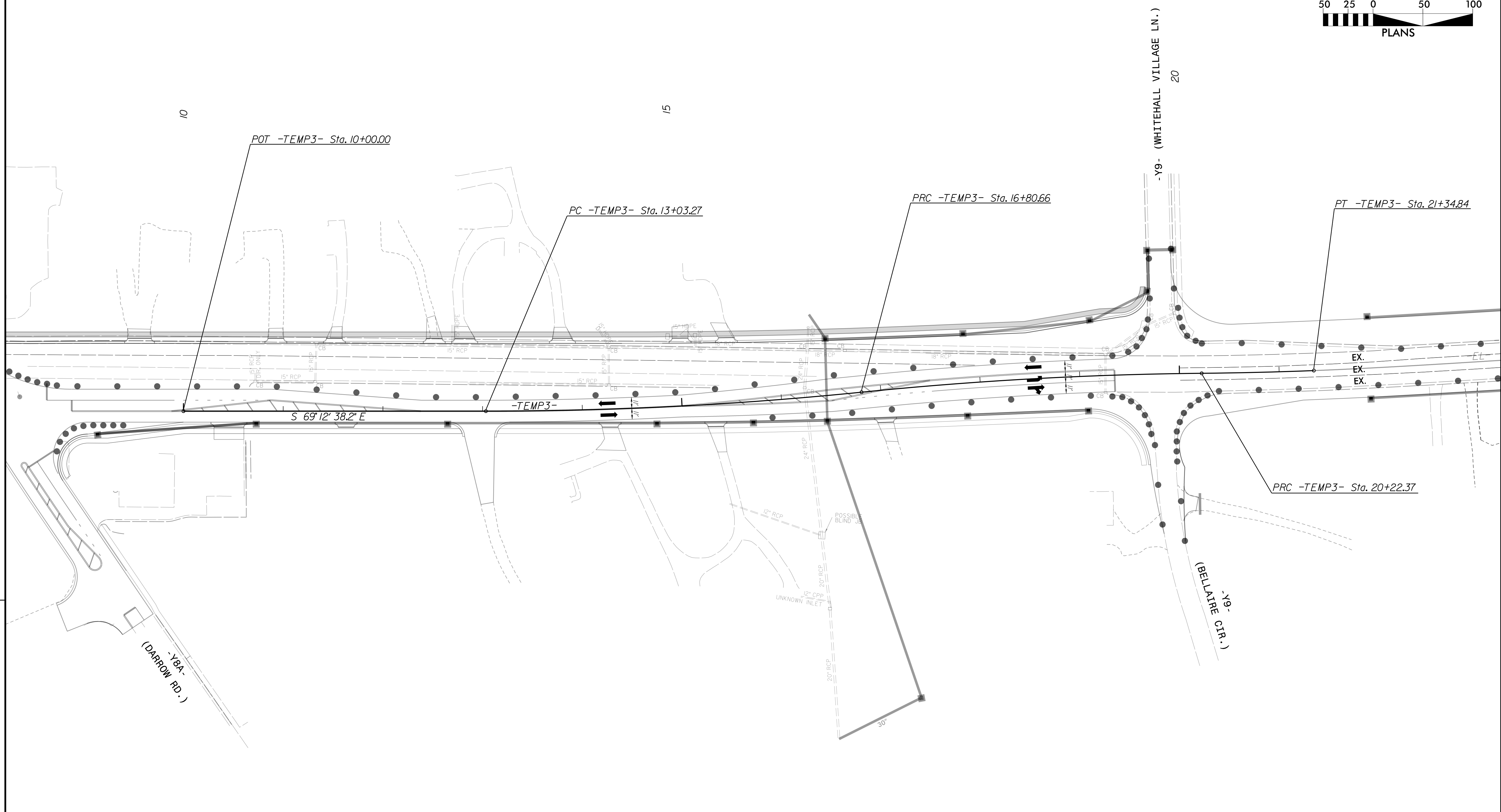
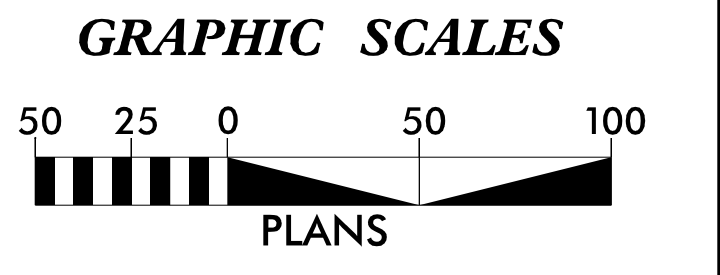
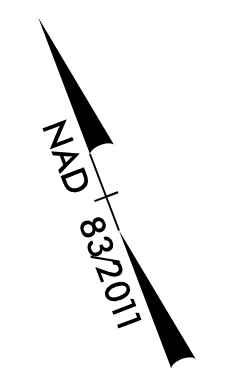

-Y8A-  
(DARROW RD.)

-Y9- (WHITEHALL VILLAGE LN.)  
20

(BELLARIE CIR.)  
-Y6-

PRC -TEMP3- Sta. 20+22.37



EX.  
EX.  
EX.



# TEMPORARY ALIGNMENT 4 DETAIL

FOR TRAFFIC CONTROL  
DETAILS SEE SHEET TMP PLANS.

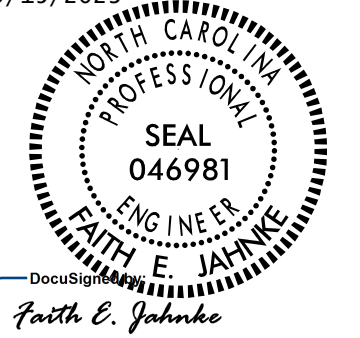
FOR PROPOSED DRAINAGE, ROADWAY  
FEATURES, AND RIGHT OF WAY  
SEE PSH 4.



PROJECT REFERENCE NO. <i>U-5824</i>	SHEET NO. <i>2B-11</i>
RW SHEET NO.	
ROADWAY DESIGN ENGINEER 9/15/2023	HYDRAULICS ENGINEER
	
<b>DOCUMENT NOT CONSIDERED FINAL UNLESS ALL SIGNATURES COMPLETED</b>	
Prepared in the Office of:	

PI Sta 16+75.18  
 $\Delta = 49^{\circ} 58' 56.1''$  (LT)  
 $D = 6^{\circ} 01' 52.1''$   
 $L = 828.74'$   
 $T = 442.81'$   
 $R = 950.00'$   
 $SE = 4\%$   
 $RO = 192'$

-TEMP4-

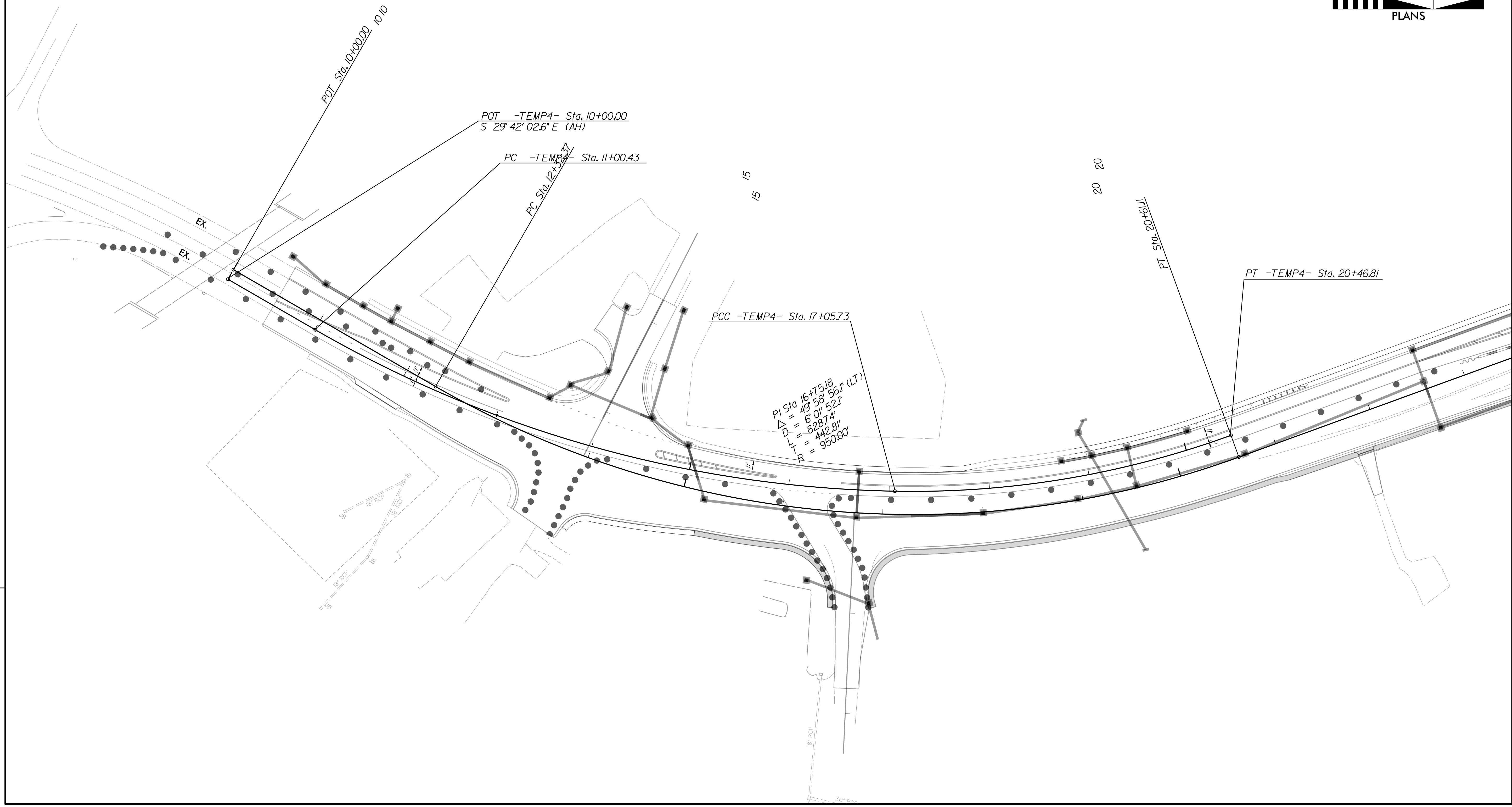
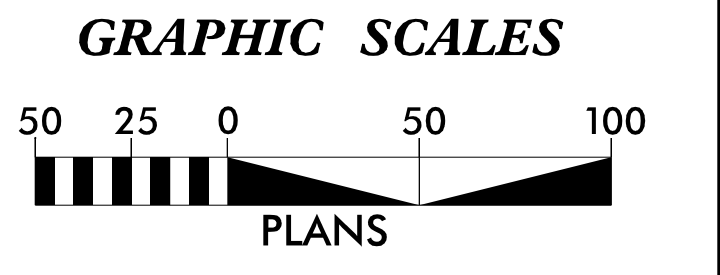
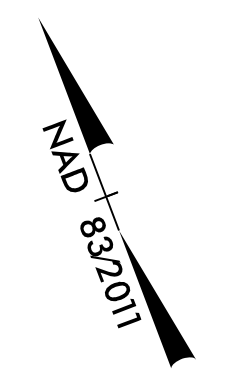
PI Sta 14+09.66 $\Delta = 28^{\circ} 54' 02.8''$ (LT) $D = 4^{\circ} 46' 28.7''$ $L = 605.30'$ $T = 309.23'$ $R = 1,200.00'$	PI Sta 18+78.22 $\Delta = 2^{\circ} 04' 53.3''$ (LT) $D = 6^{\circ} 10' 50.8''$ $L = 341.08'$ $T = 172.49'$ $R = 927.00'$
---	--

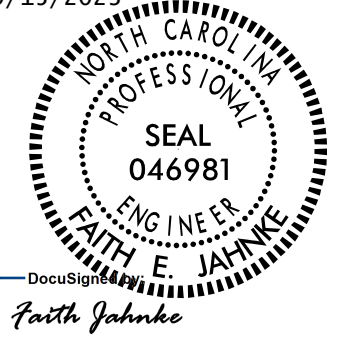

PROJECT REFERENCE NO. <i>U-5824</i>	SHEET NO. <i>2B-12</i>
RW SHEET NO.	
ROADWAY DESIGN ENGINEER 9/15/2023	HYDRAULICS ENGINEER
	
<b>DOCUMENT NOT CONSIDERED FINAL UNLESS ALL SIGNATURES COMPLETED</b>	
Prepared in the Office of:	

60  
 FOR TRAFFIC CONTROL  
 DETAILS SEE TMP PLANS.  
 FOR PROPOSED DRAINAGE, ROADWAY  
 FEATURES, AND RIGHT OF WAY  
 SEE PSH-7.

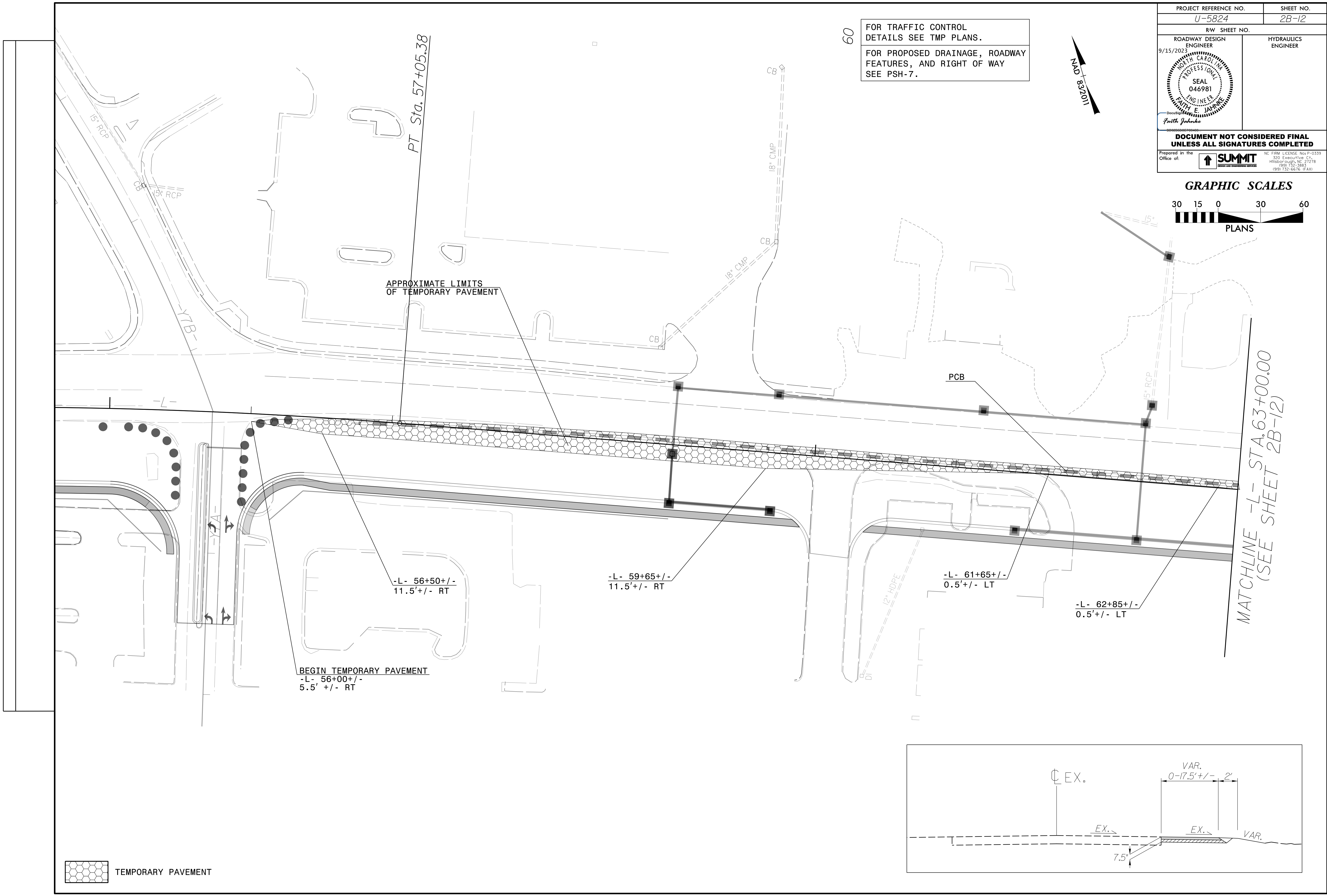
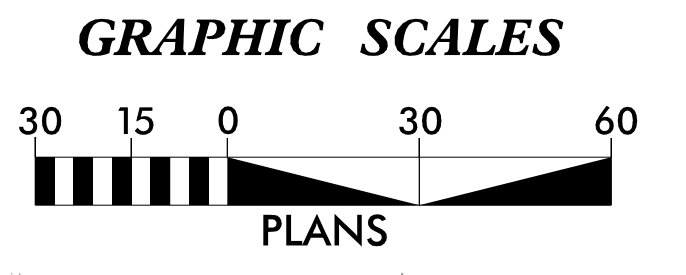
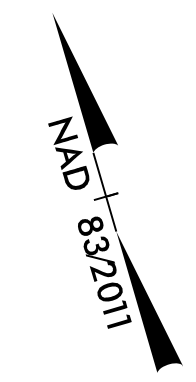

 TEMPORARY PAVEMENT

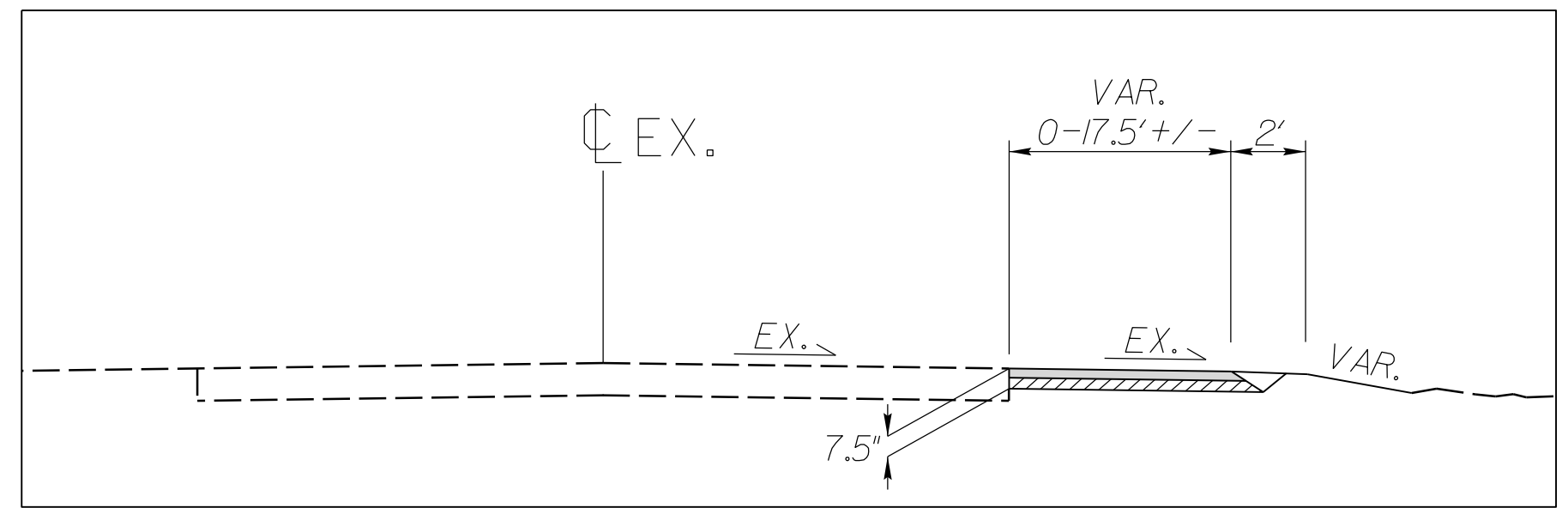



65

70

FOR TRAFFIC CONTROL  
DETAILS SEE TMP PLANS.  
FOR PROPOSED DRAINAGE, ROADWAY  
FEATURES, AND RIGHT OF WAY  
SEE PSH-8.

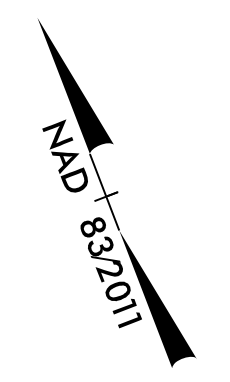

PROJECT REFERENCE NO. U-5824	SHEET NO. 2B-13
RW SHEET NO.	
ROADWAY DESIGN ENGINEER 9/15/2023	HYDRAULICS ENGINEER
<p><b>DOCUMENT NOT CONSIDERED FINAL UNLESS ALL SIGNATURES COMPLETED</b></p>	
Prepared in the Office of:	 <small>NC FIRM LICENSE No: P-0339 300 Executive Ct. Hillsborough, NC 27278 (919) 732-3883 (919) 732-6676 (FAX)</small>

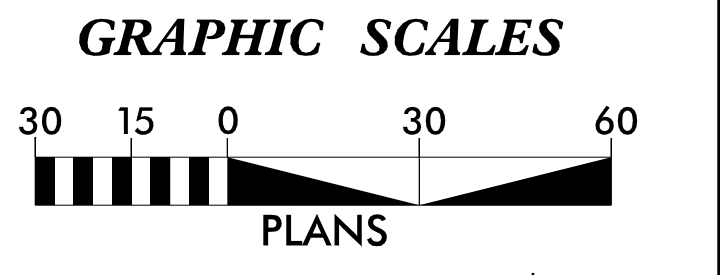

MATCHLINE -L- STA. 63+00.00  
(SEE SHEET 2B-11)

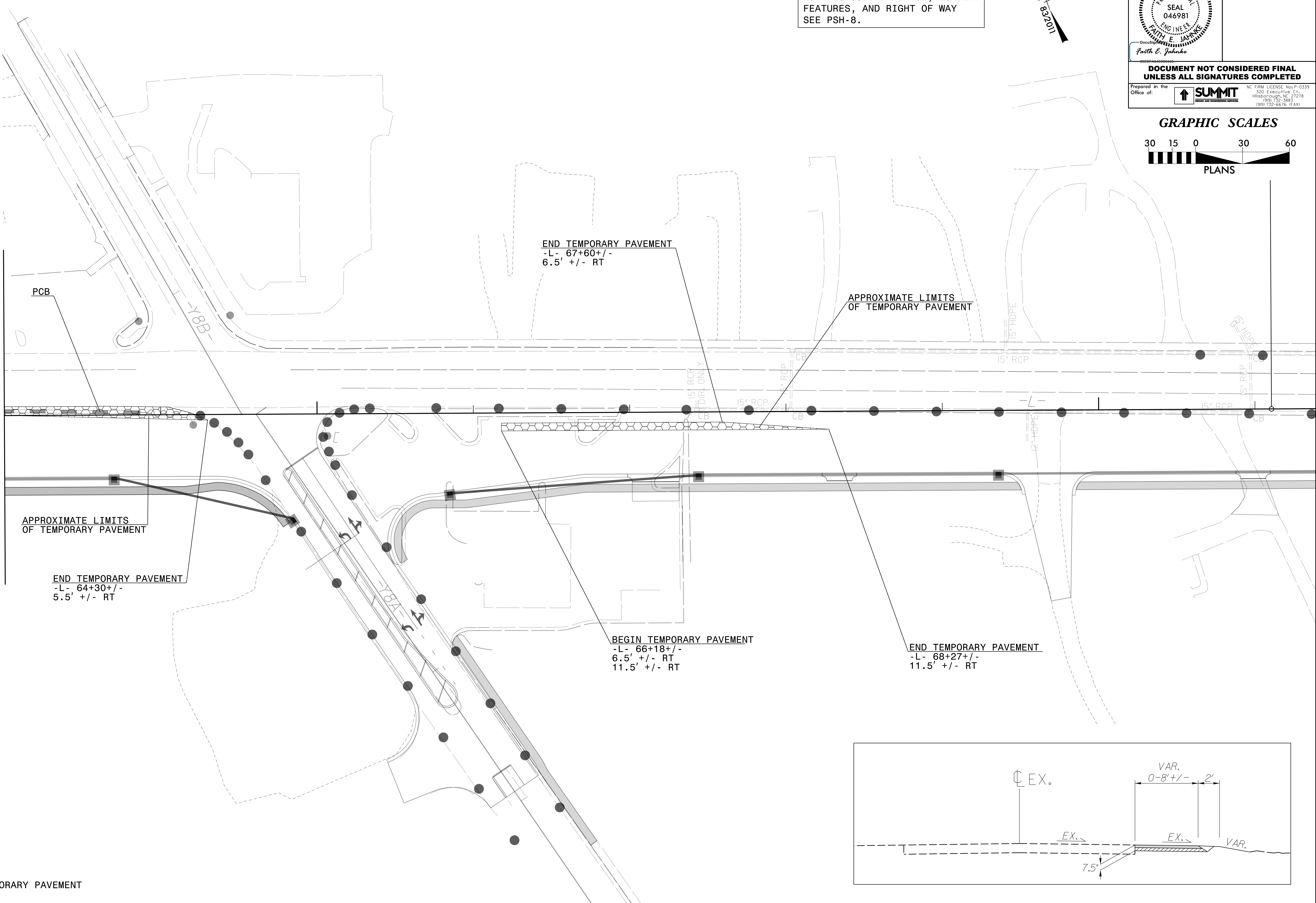

END TEMPORARY PAVEMENT  
-L- 67+60 +/-  
6.5' +/- RT

APPROXIMATE LIMITS  
OF TEMPORARY PAVEMENT

APPROXIMATE LIMITS  
OF TEMPORARY PAVEMENT

END TEMPORARY PAVEMENT  
-L- 64+30 +/-  
5.5' +/- RT

BEGIN TEMPORARY PAVEMENT  
-L- 66+18 +/-  
6.5' +/- RT  
11.5' +/- RT

END TEMPORARY PAVEMENT  
-L- 68+27 +/-  
11.5' +/- RT

TEMPORARY PAVEMENT

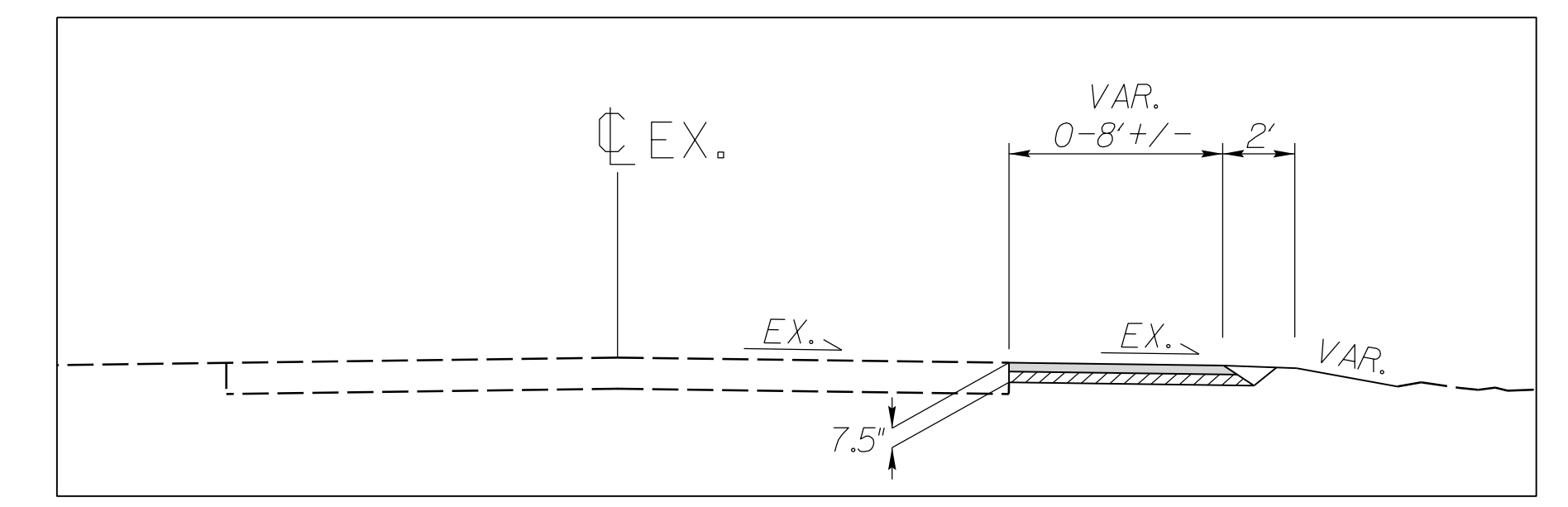

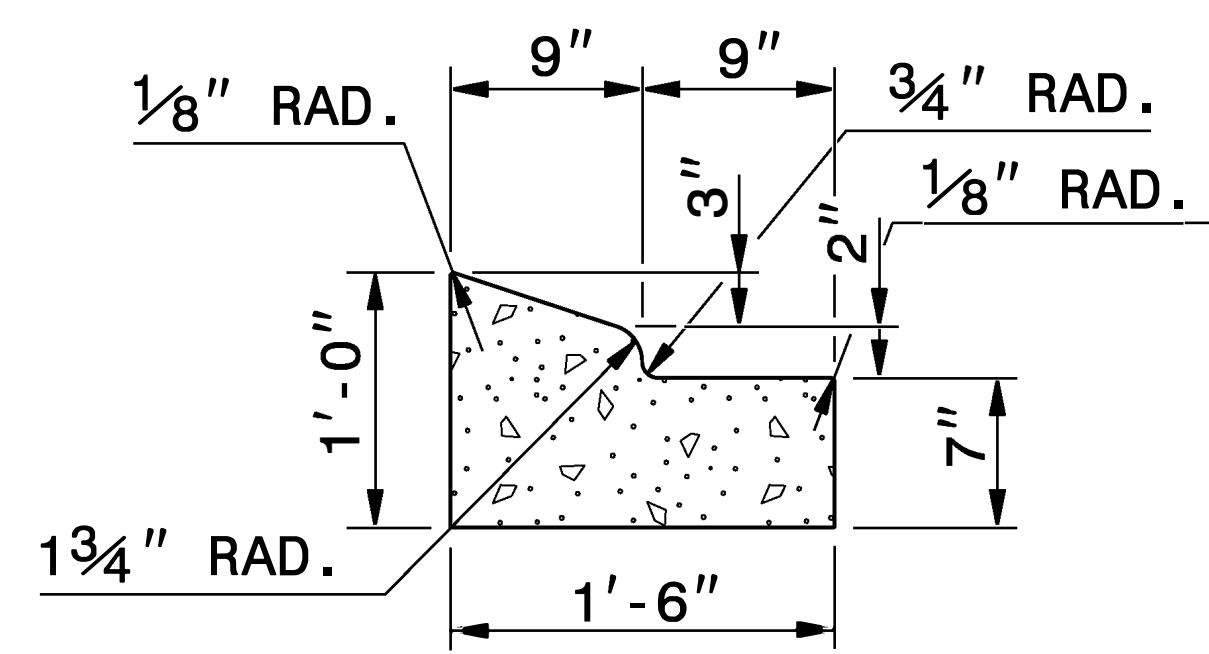

**1'-6" CURB AND GUTTER**

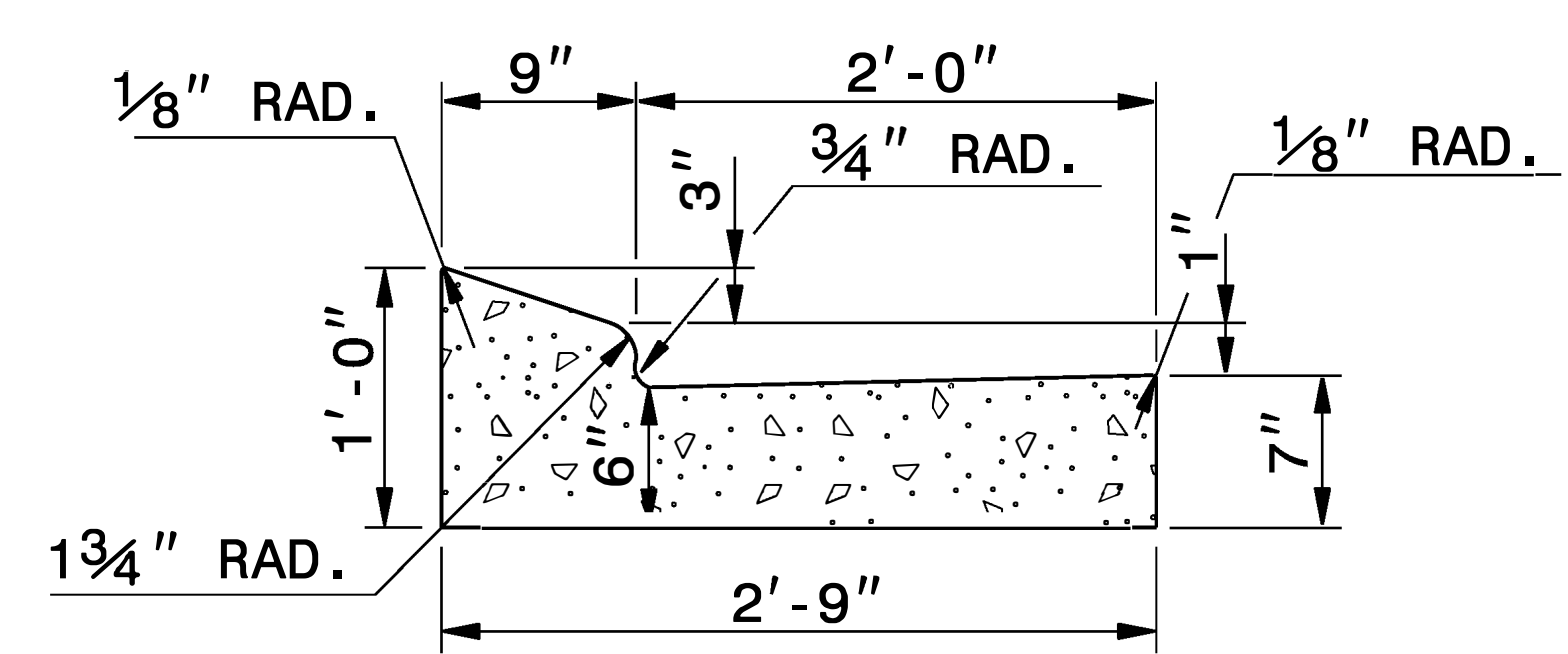

**2'-9" CURB AND GUTTER**

NOTE: SEE STD. DWG. 846.01 FOR ADDITIONAL CURB AND GUTTER INFORMATION.

SEE ROADWAY PLANS FOR LOCATION OF CURB TRANSITION.

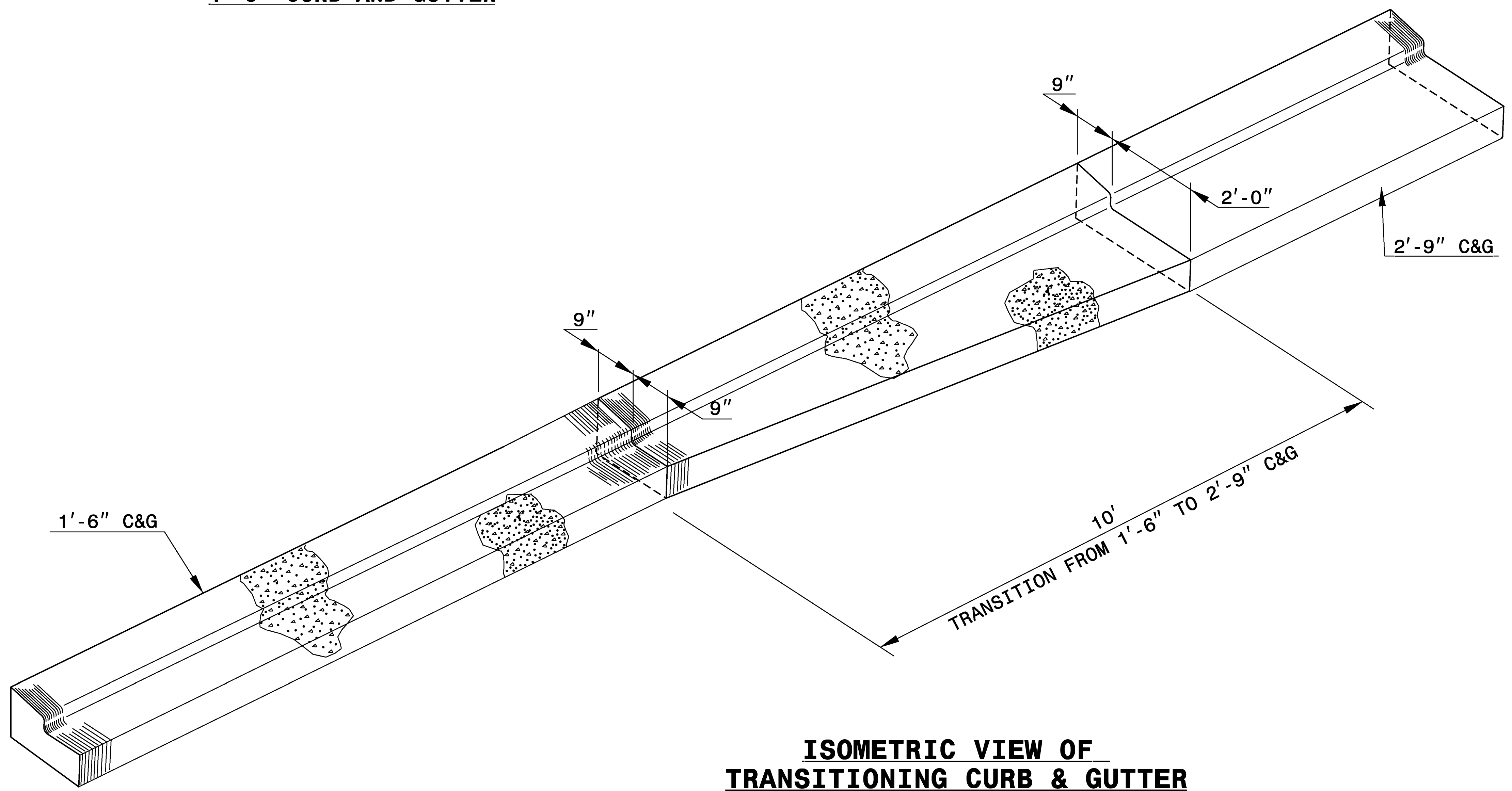

**ISOMETRIC VIEW OF  
TRANSITIONING CURB & GUTTER**

9/14/2023

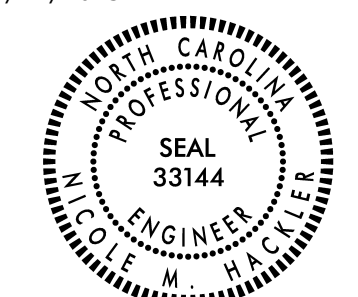

DocuSigned by:  
*Nicole M. Heckler*  
5884323034164CS

DOCUMENT NOT CONSIDERED FINAL  
UNLESS ALL SIGNATURES COMPLETED

**CONTRACT STANDARDS  
AND DEVELOPMENT UNIT**  
Office 919-707-6950 FAX 919-250-4119

**DETAIL OF 1'-6"  
TO 2'-9" CURB & GUTTER  
TRANSITION SECTION**

ORIGINAL BY: T.S. SPELL	DATE: NOV. 26, 2001
MODIFIED BY: T.S. SPELL	DATE: JAN. 23, 2007
CHECKED BY:	DATE:
FILE SPEC.: DS174:\usr\details\stand\catransit.dgn	



5/14/23

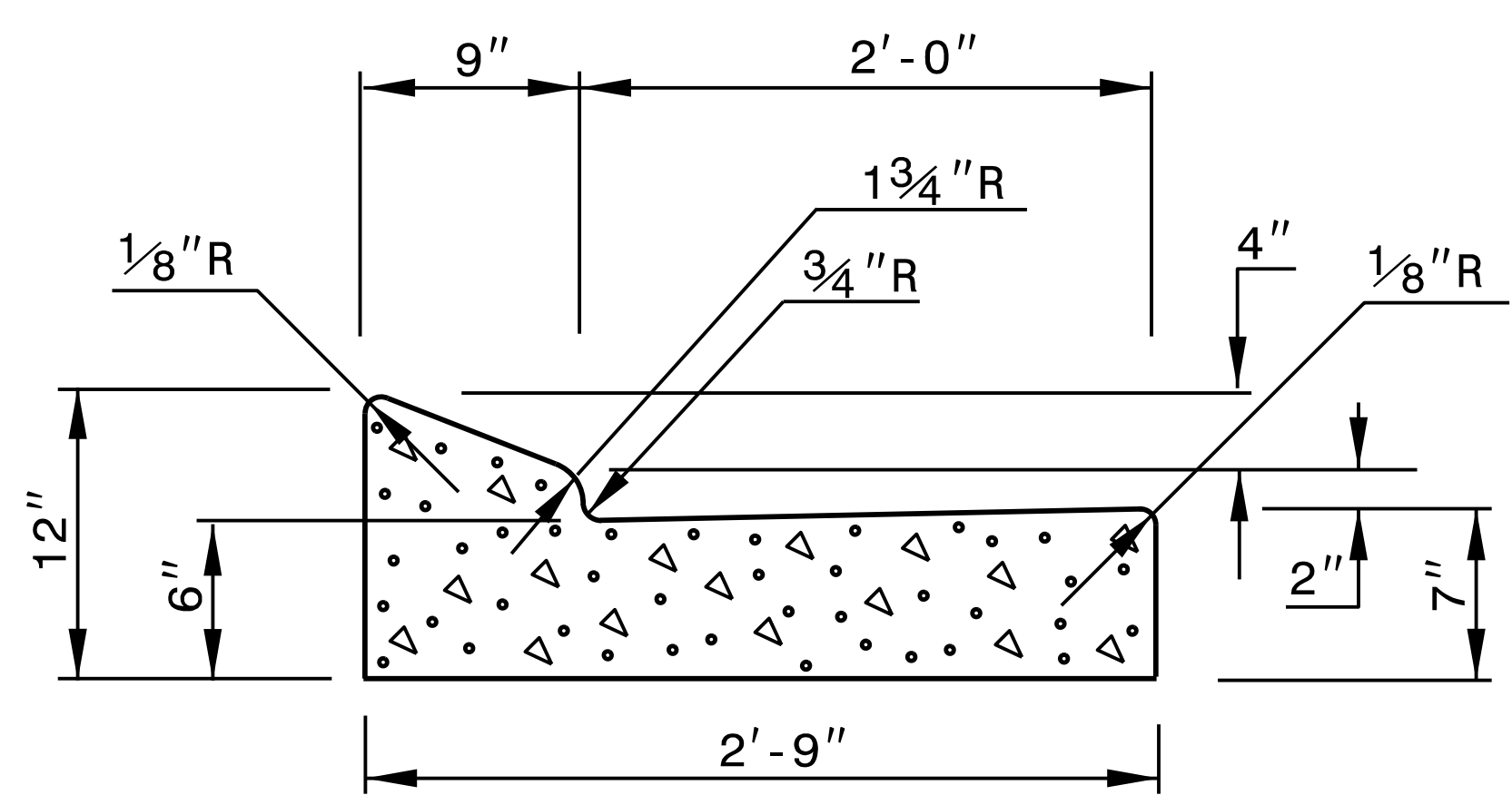

**PROPOSED 2'-9" CURB & GUTTER**

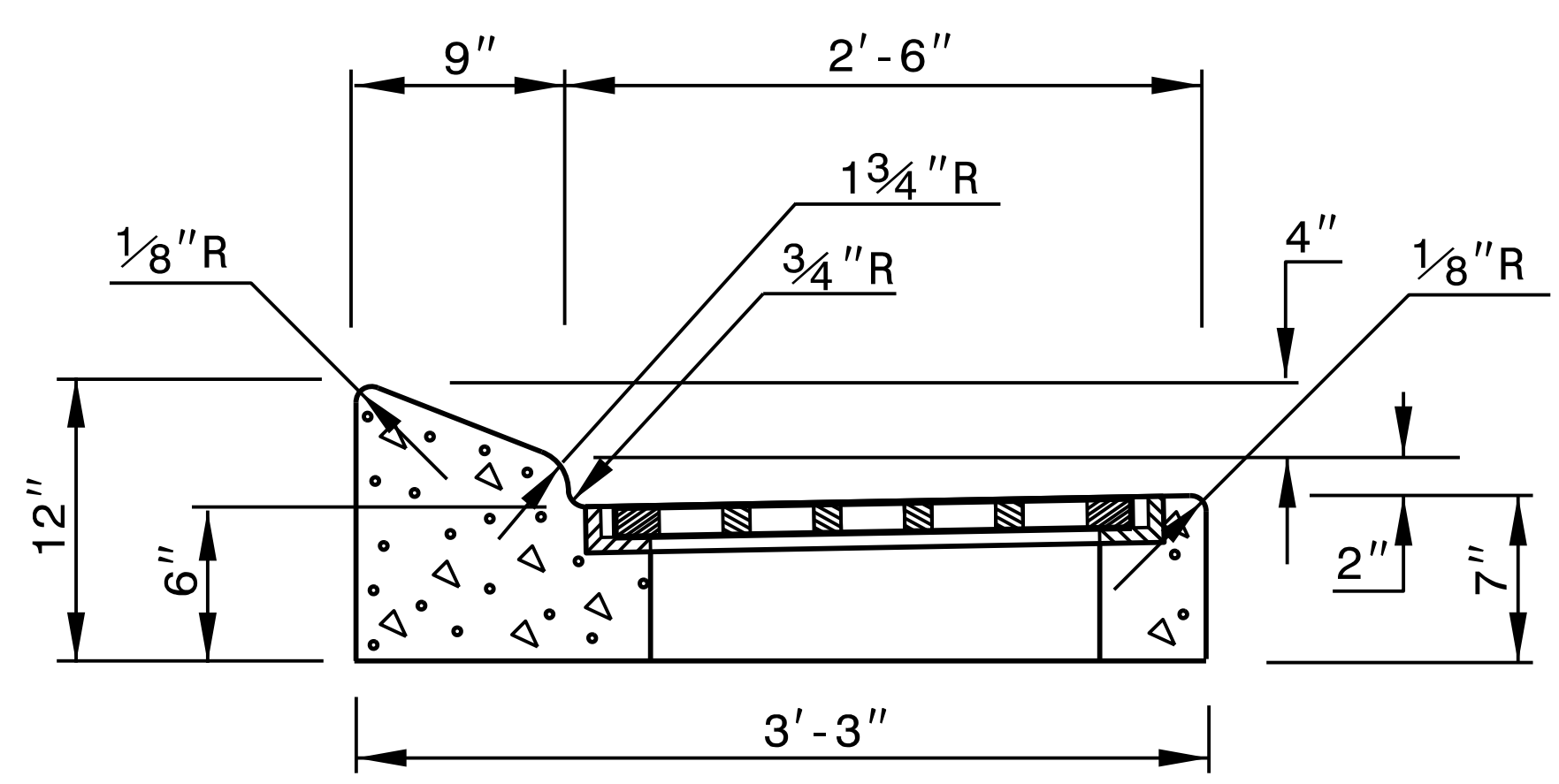

**FRAME AND GRATE IN PROPOSED 2'-9" CURB & GUTTER**

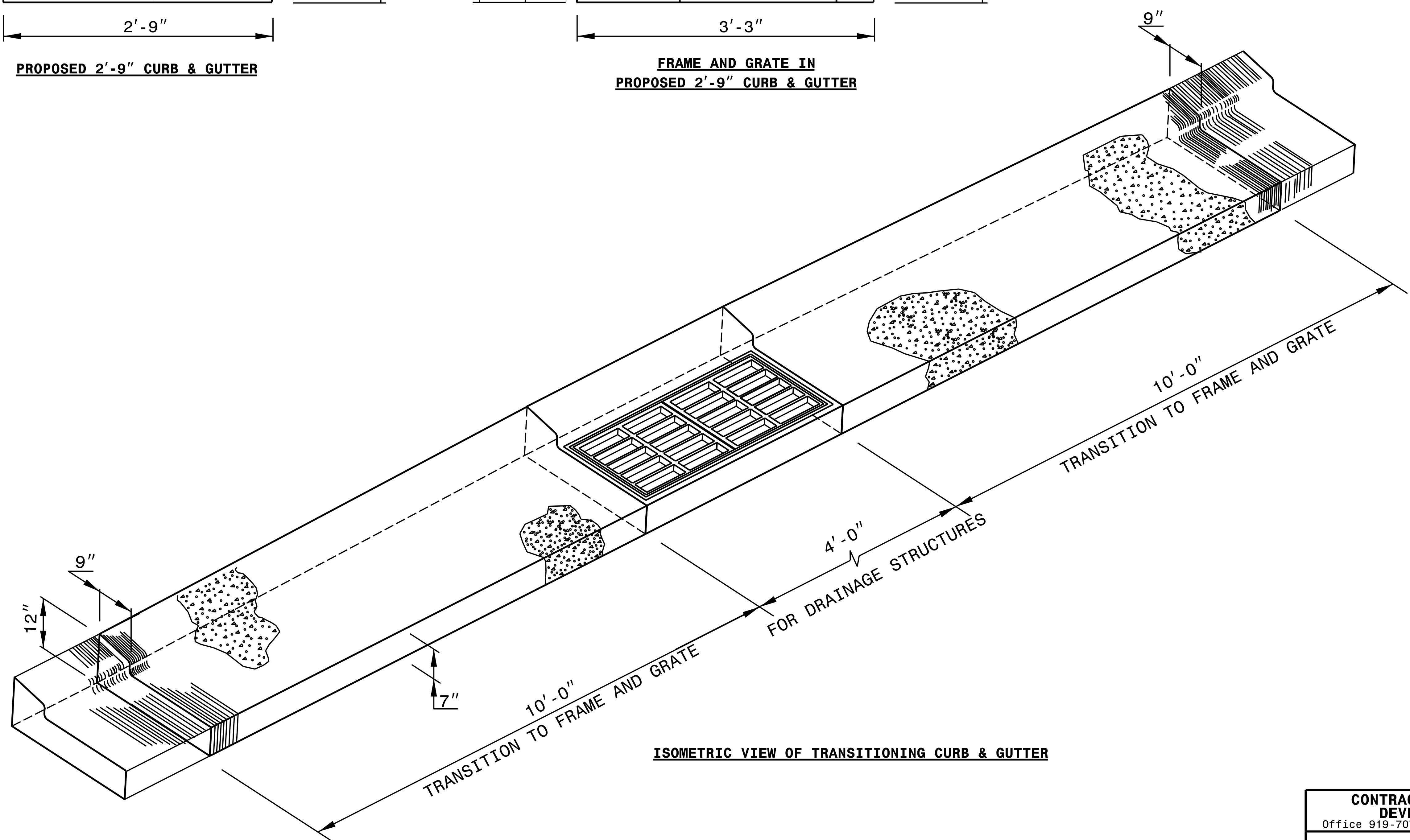

**ISOMETRIC VIEW OF TRANSITIONING CURB & GUTTER**

9/14/2023



DocuSigned by:  
Nicole M. Hecker  
588432034164C5...

DOCUMENT NOT CONSIDERED FINAL  
UNLESS ALL SIGNATURES COMPLETED

**CONTRACT STANDARDS AND DEVELOPMENT UNIT**  
 Office 919-707-6950 FAX 919-250-4119

**DETAIL OF 2'-9" TO FRAME AND GRATE**

ORIGINAL BY: _____	DATE: _____
MODIFIED BY: _____	DATE: _____
CHECKED BY: _____	DATE: _____
FILE SPEC.: <a href="#">kkempf/english/curb_gutter_transition.dgn</a>	

\*NOTE: SEE STD. DWG. 846.01  
FOR 2'-6" CURB AND GUTTER  
INFORMATION.

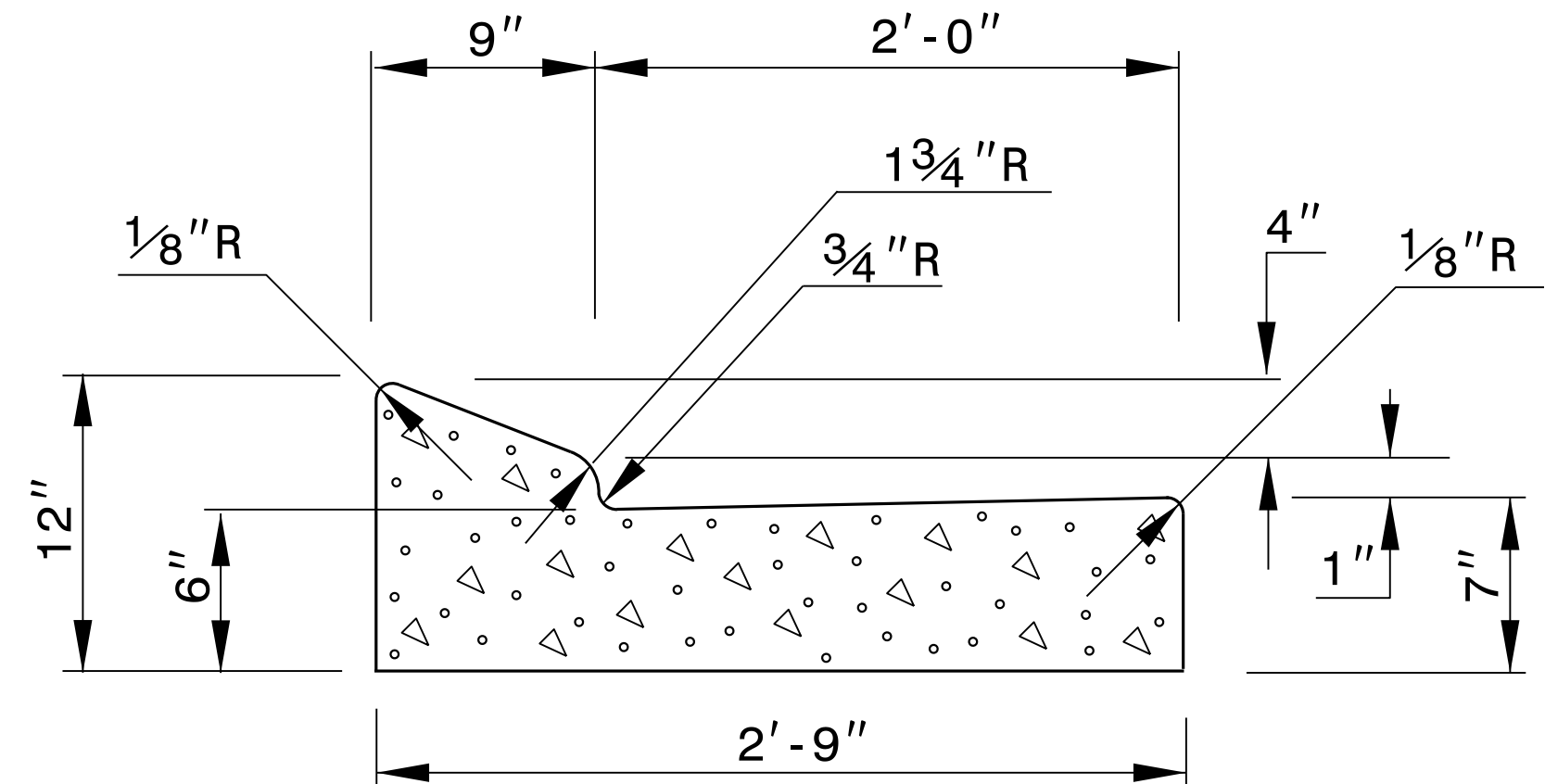

**PROPOSED 2'-9" CURB & GUTTER**

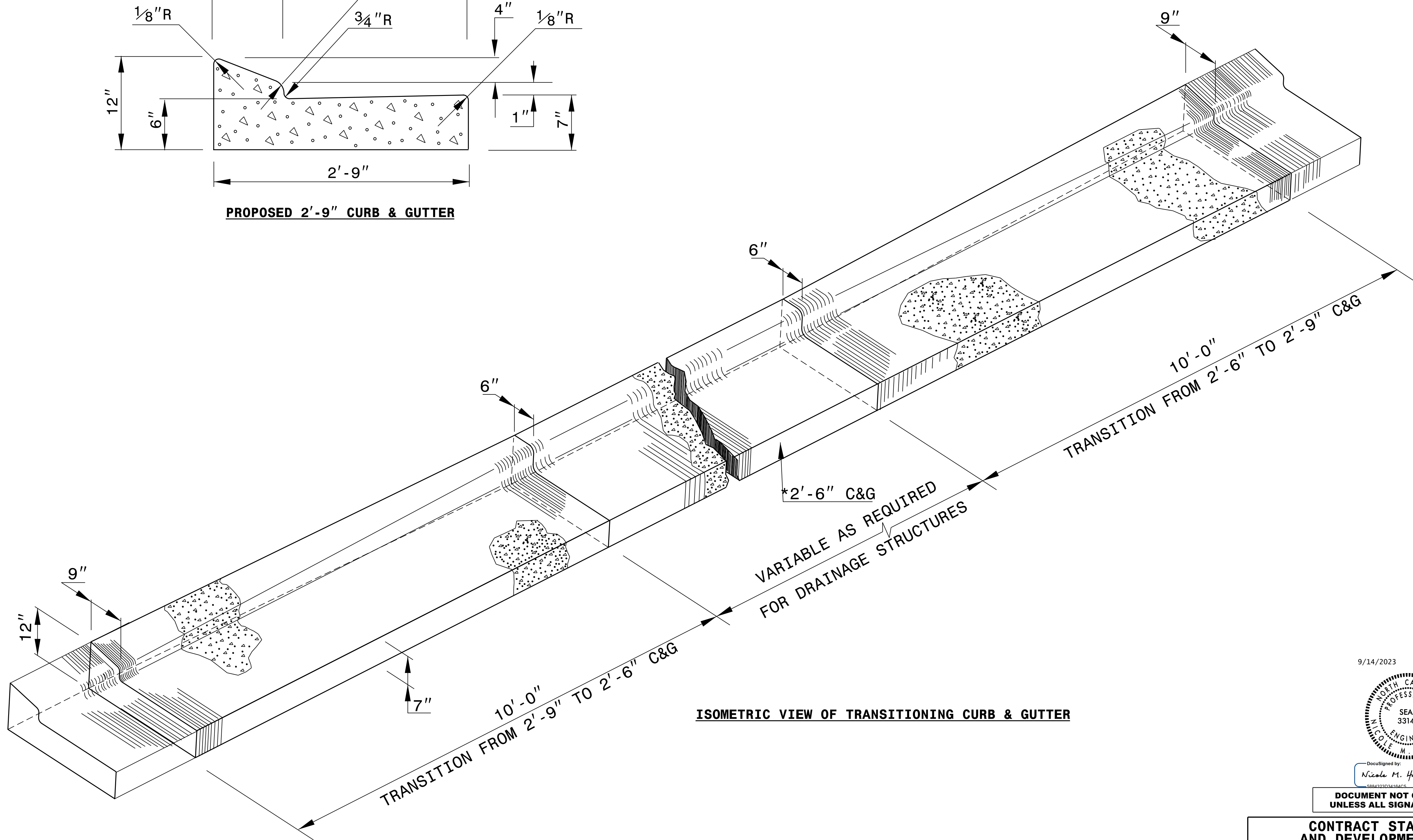

**ISOMETRIC VIEW OF TRANSITIONING CURB & GUTTER**

9/14/2023

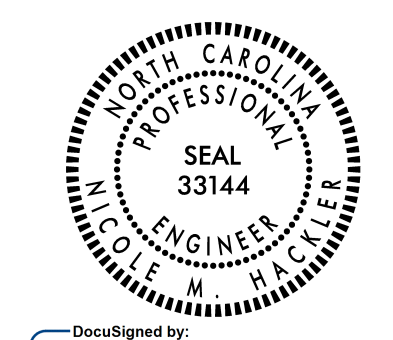

DocuSigned by:  
Nicole M. Hacker  
6894292346465

**DOCUMENT NOT CONSIDERED FINAL  
UNLESS ALL SIGNATURES COMPLETED**

**CONTRACT STANDARDS  
AND DEVELOPMENT UNIT**  
Office 919-707-6950 FAX 919-250-4119

**DETAIL OF 2'-9"  
TO 2'-6" CURB & GUTTER  
TRANSITION SECTION**

ORIGINAL BY: \_\_\_\_\_ DATE: \_\_\_\_\_  
MODIFIED BY: \_\_\_\_\_ DATE: \_\_\_\_\_  
CHECKED BY: \_\_\_\_\_ DATE: \_\_\_\_\_  
FILE SPEC.: D8174:usr/details/stand/cgtransit.dgn



STATE OF NORTH CAROLINA  
DEPT. OF TRANSPORTATION  
DIVISION OF HIGHWAYS  
RALEIGH, N.C.

ROADWAY DETAIL DRAWING FOR  
**GUARDRAIL INSTALLATION**

SHEET 6 OF 8  
**862D02**

STATE OF NORTH CAROLINA  
DEPT. OF TRANSPORTATION  
DIVISION OF HIGHWAYS  
RALEIGH, N.C.

ROADWAY DETAIL DRAWING FOR  
**GUARDRAIL INSTALLATION**

SHEET 6 OF 8  
**862D02**

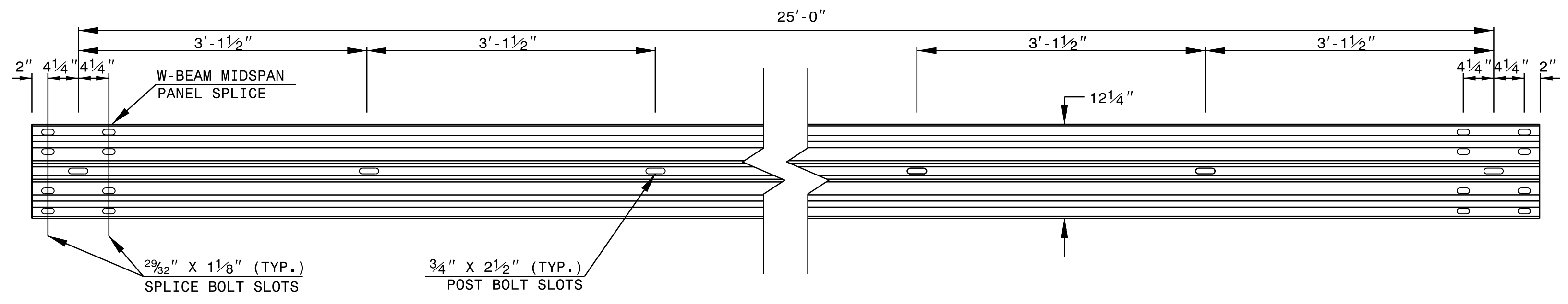

**STANDARD W-BEAM GUARDRAIL**

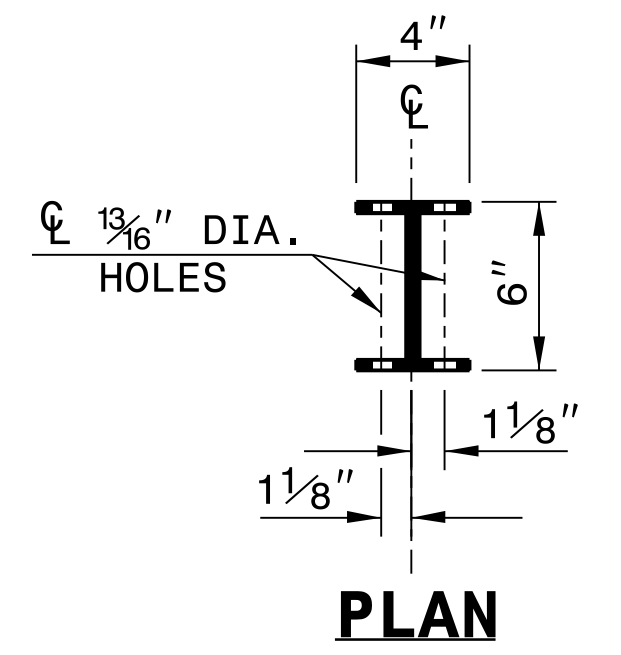

**PLAN**

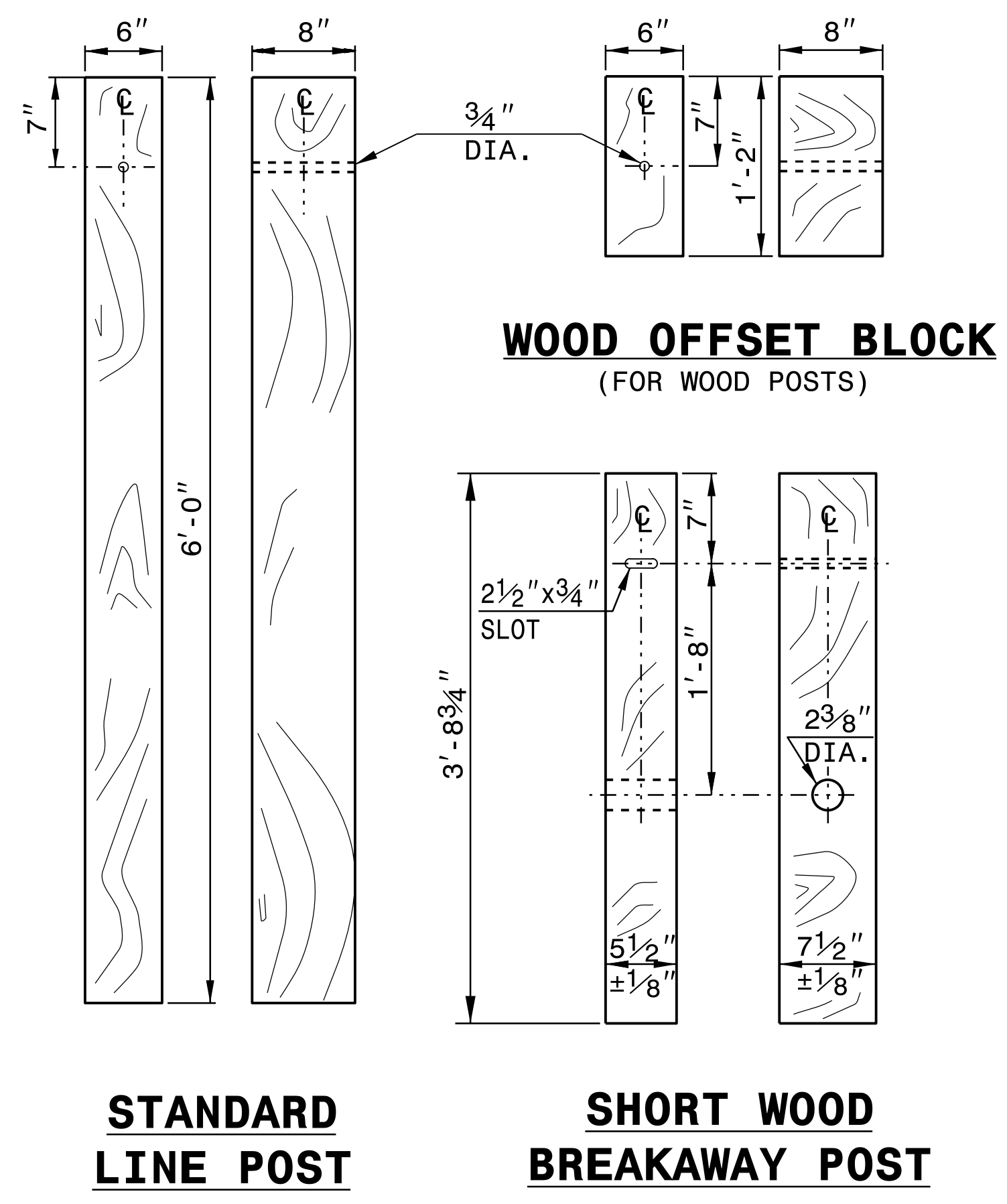

**STANDARD LINE POST**

**SHORT WOOD BREAKAWAY POST**

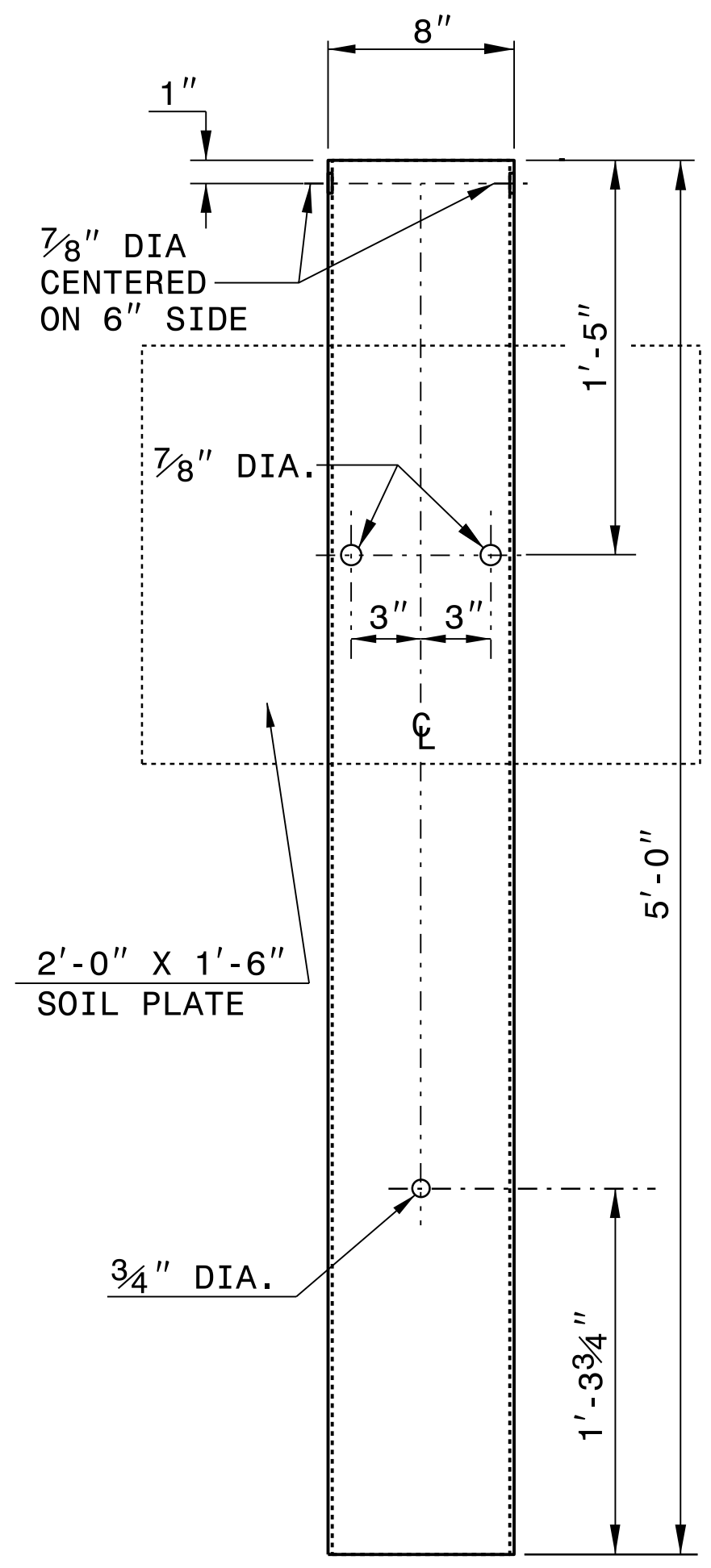

**STEEL TUBE**  
TS 6"x8"x0.1875"

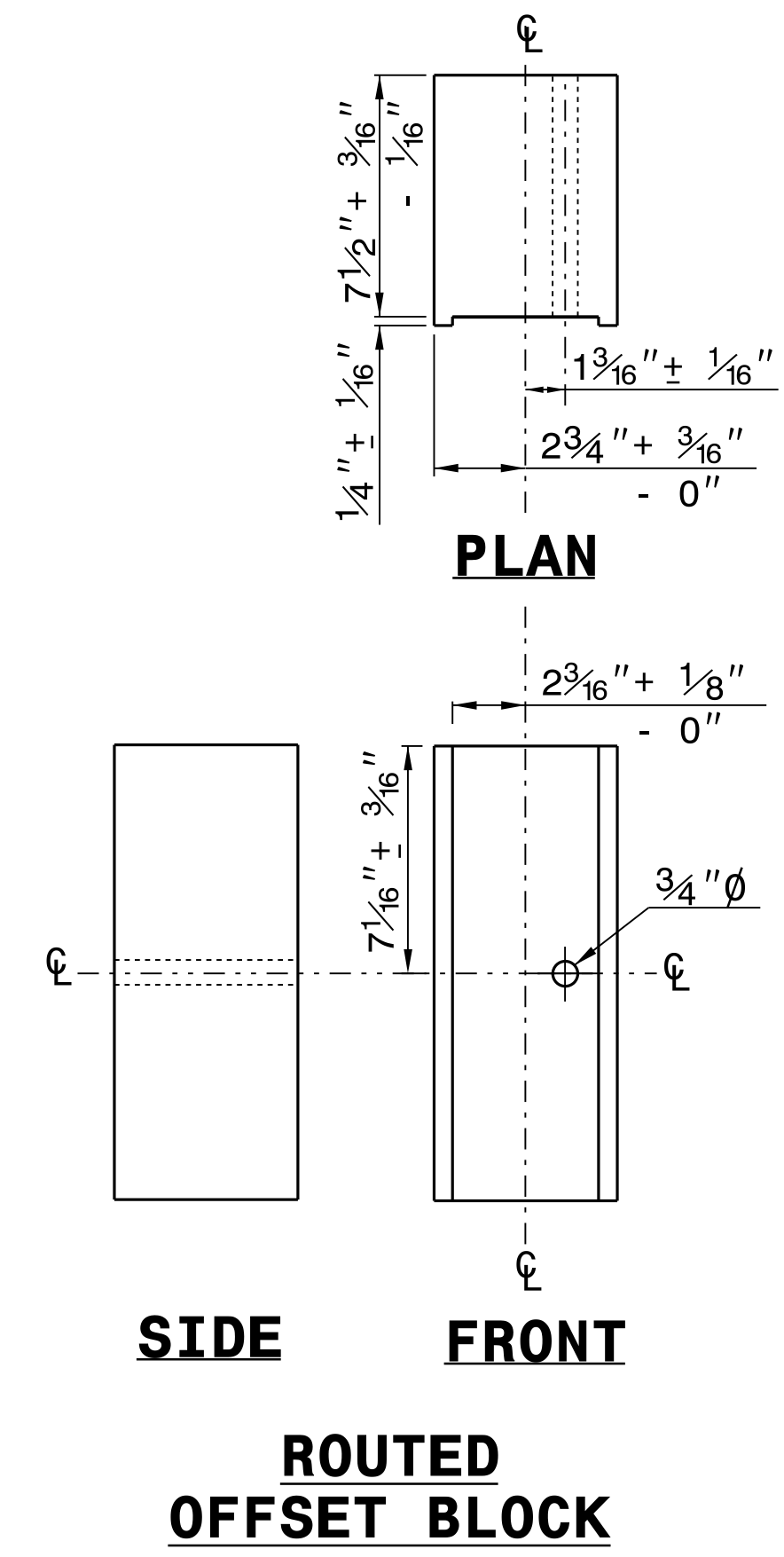

**SIDE**

**FRONT**

**PLAN**

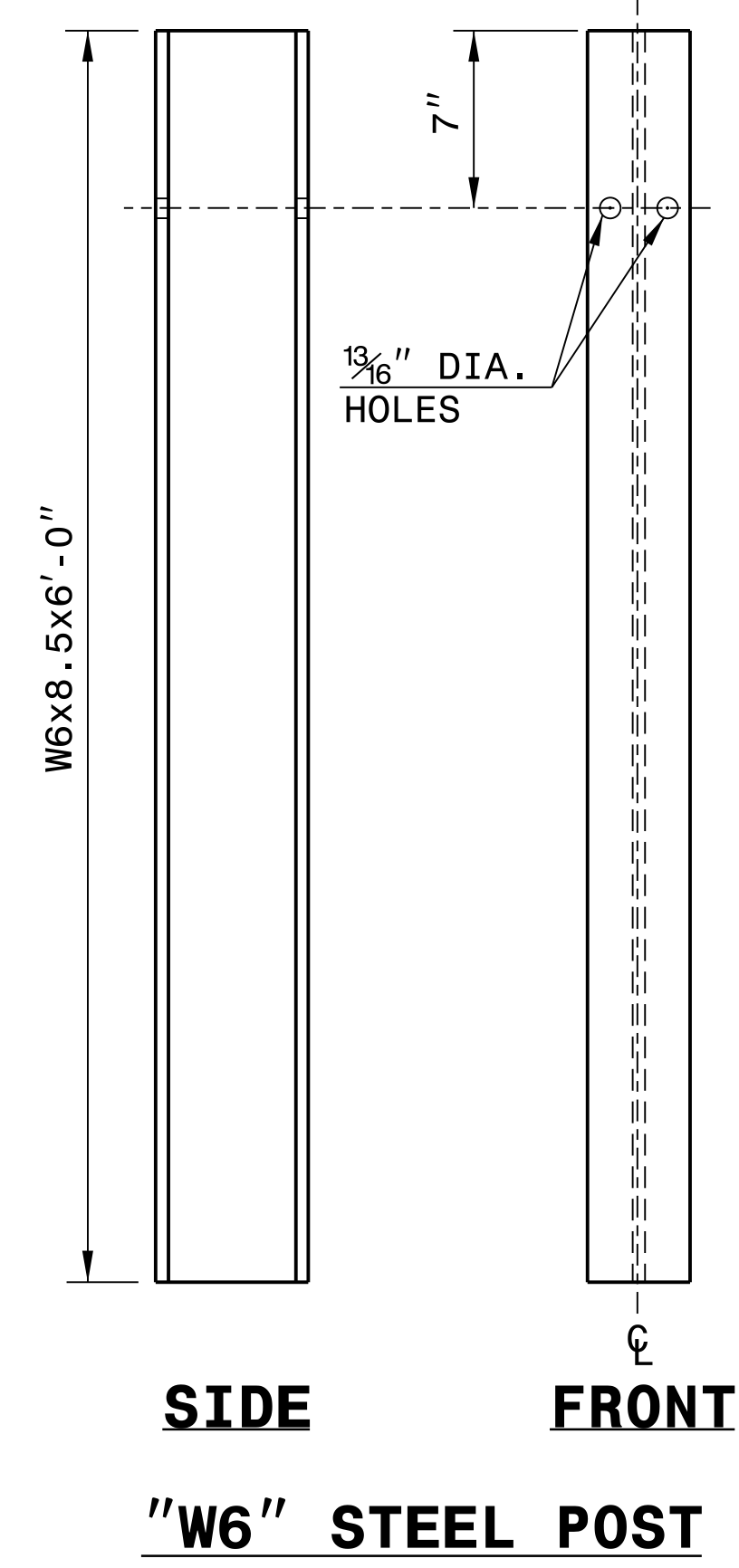

**SIDE**

**FRONT**

**"W6" STEEL POST**

**SYSTEM PARTS**

9/14/2023

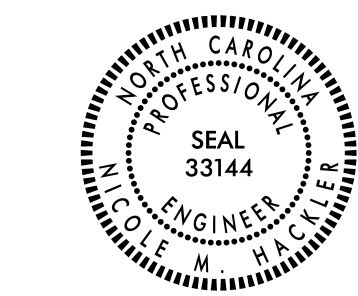

DocuSigned by:  
Nicole M. Hecker  
5884320341645

**CONTRACTS STANDARDS AND DEVELOPMENT UNIT**  
Office 919-707-6950 FAX 919-250-4119

**SEE TITLE BLOCK**

ORIGINAL BY: J. HOWERTON DATE: 3-7-2018  
MODIFIED BY: DATE: \_\_\_\_\_  
CHECKED BY: DATE: \_\_\_\_\_  
FILE SPEC.: \_\_\_\_\_

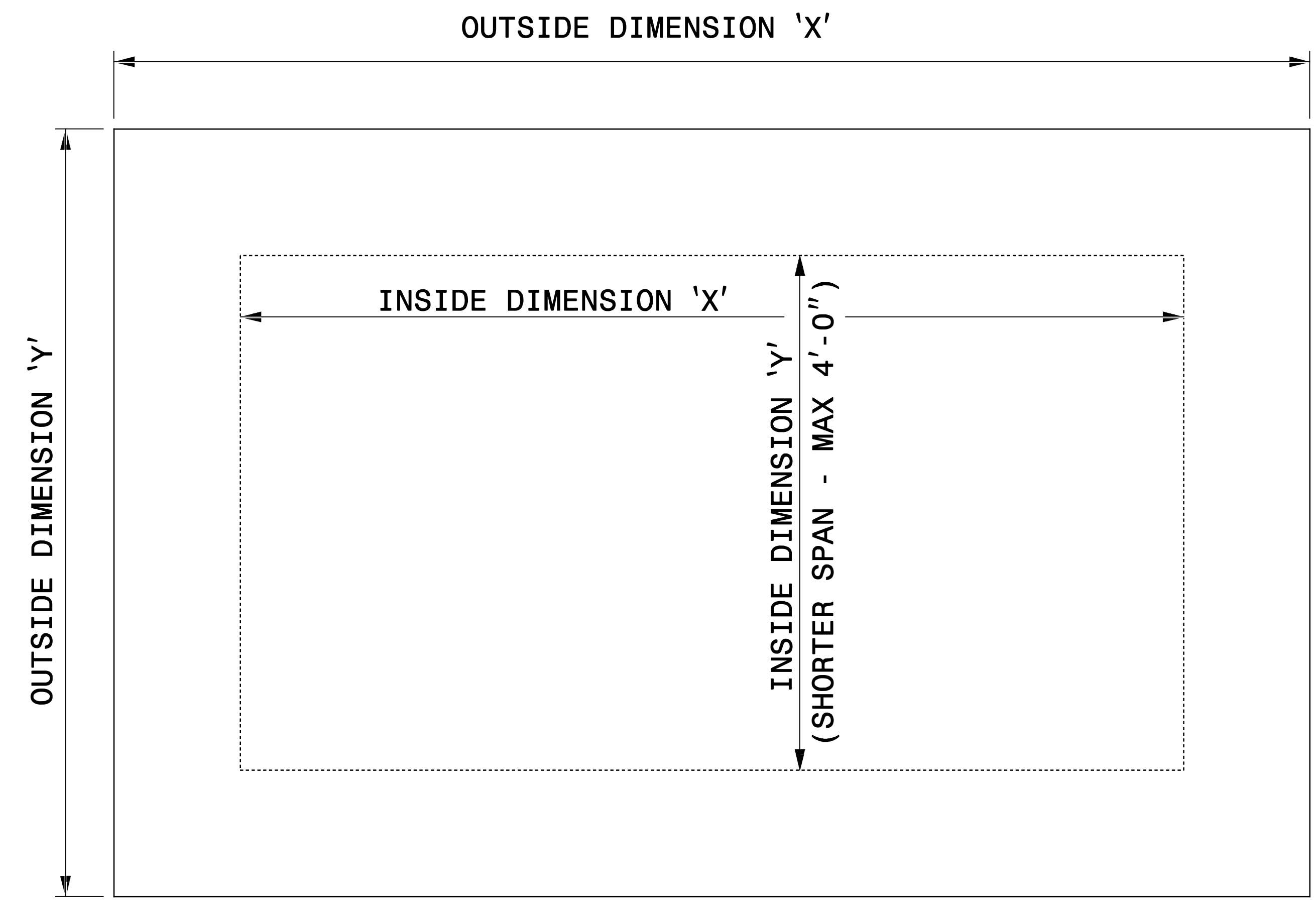

**GENERAL NOTES:**

- USE GRADE A36 STEEL
- STEEL COVERS ARE FOR TEMPORARY USE DURING PHASE CONSTRUCTION.
- FILL SHALL BE PLACED DIRECTLY OVER THE STEEL PLATES.
- SEE ROADWAY PLANS AND PROVISIONS FOR LOCATIONS
- QUANTITIES TO BE PAID FOR AT THE UNIT PRICE BID PER EACH.

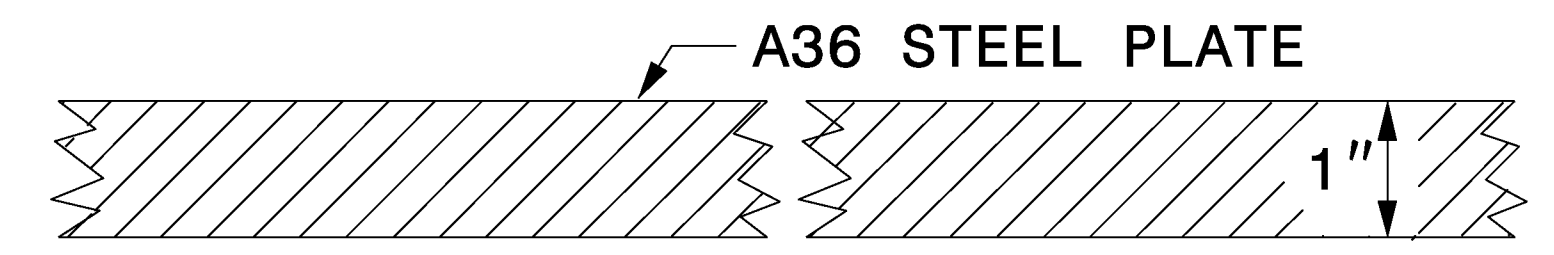

**SECTION VIEW OF STEEL TOP PLATE**

**PLAN VIEWS**

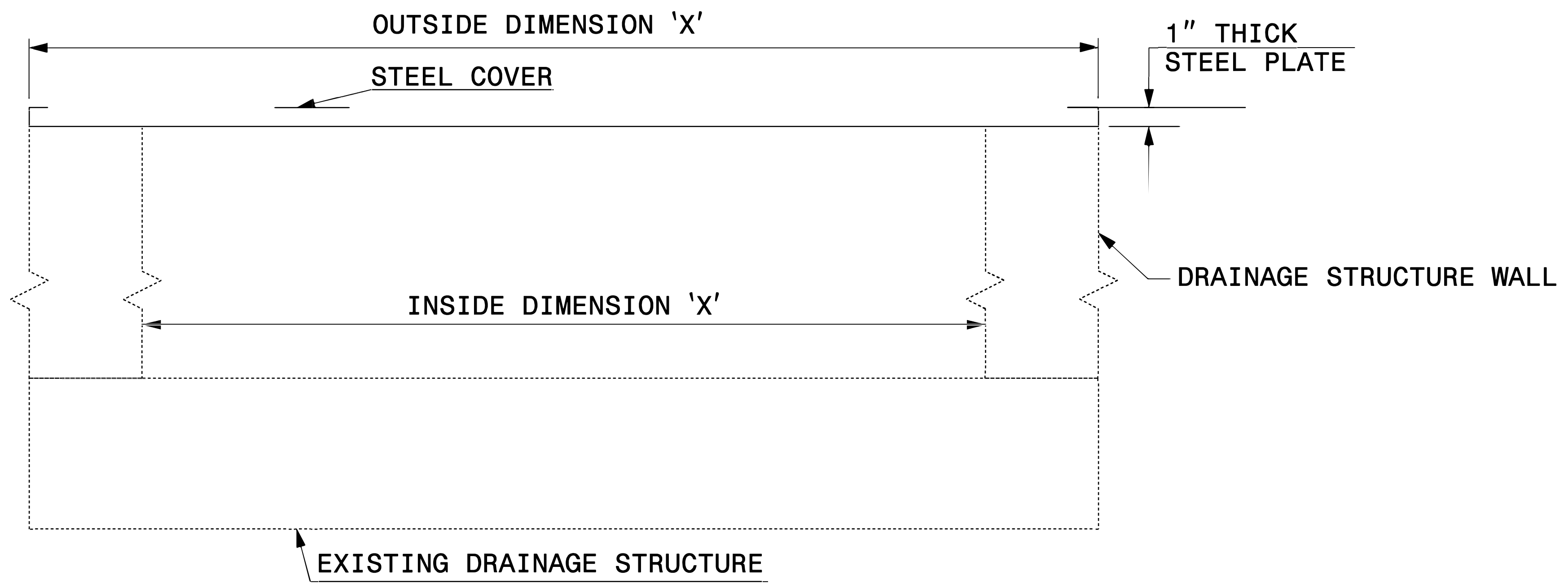

**ELEVATION VIEWS**

9/14/2023

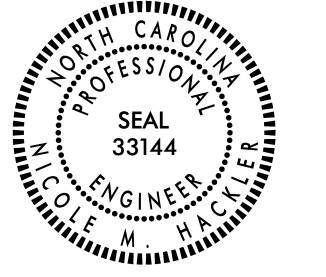

DocuSigned by:  
Nicole M. Hecker  
588432034164C5

DOCUMENT NOT CONSIDERED FINAL  
UNLESS ALL SIGNATURES COMPLETED

**CONTRACT STANDARDS  
AND DEVELOPMENT UNIT**  
Office 919-707-6950 FAX 919-250-4119

**DETAIL OF TEMPORARY  
1" STEEL COVER  
OVER DRAINAGE STRUCTURE**

ORIGINAL BY: E.E. WARD DATE: 2-2-98  
 MODIFIED BY: \_\_\_\_\_ DATE: \_\_\_\_\_  
 CHECKED BY: \_\_\_\_\_ DATE: \_\_\_\_\_  
 FILE SPEC.: eric:/usr/details/metric/stand/st1cvr2.dgn

SCHEMATIC DEVELOPMENT UNIT SURNAME



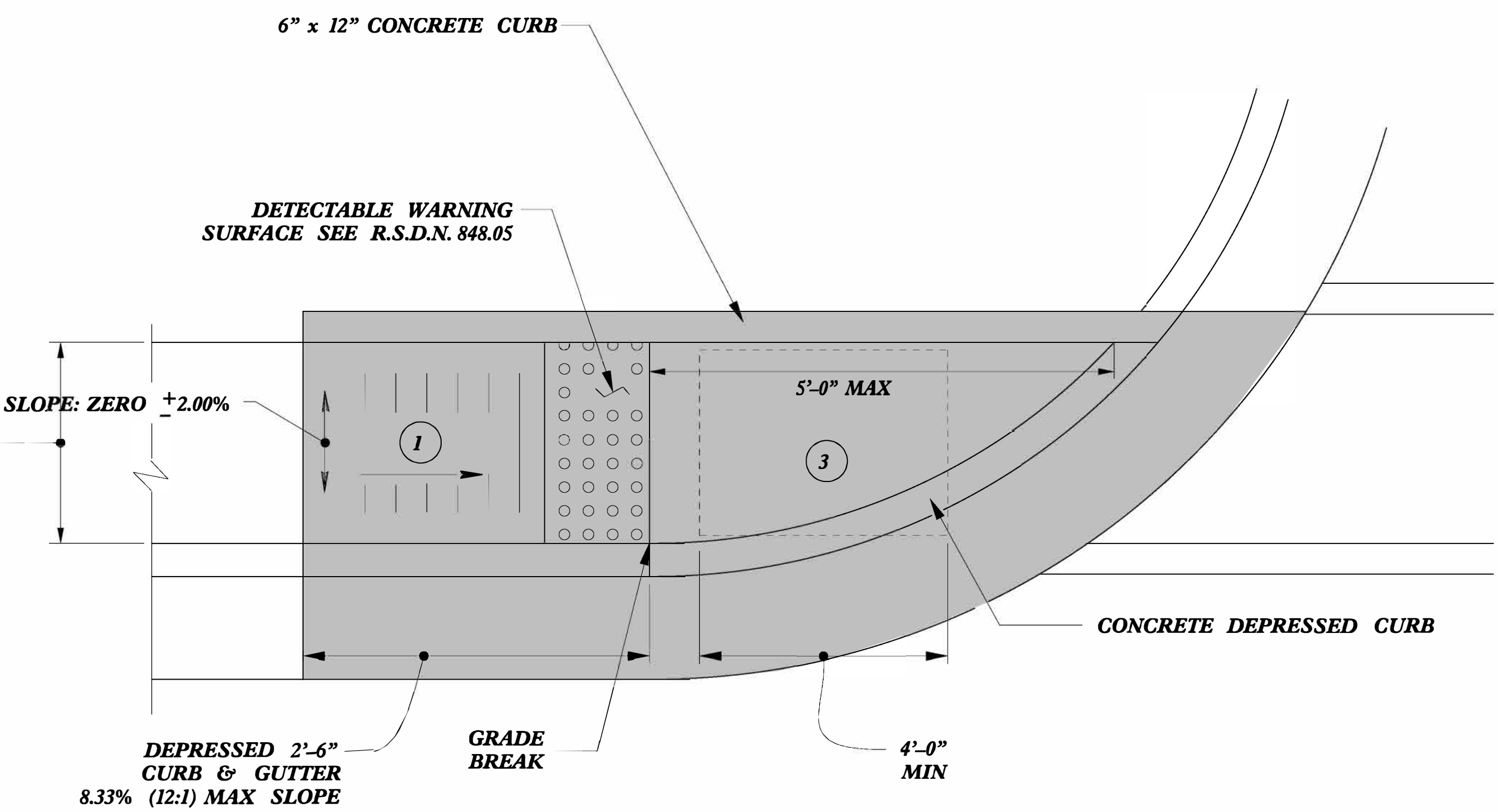
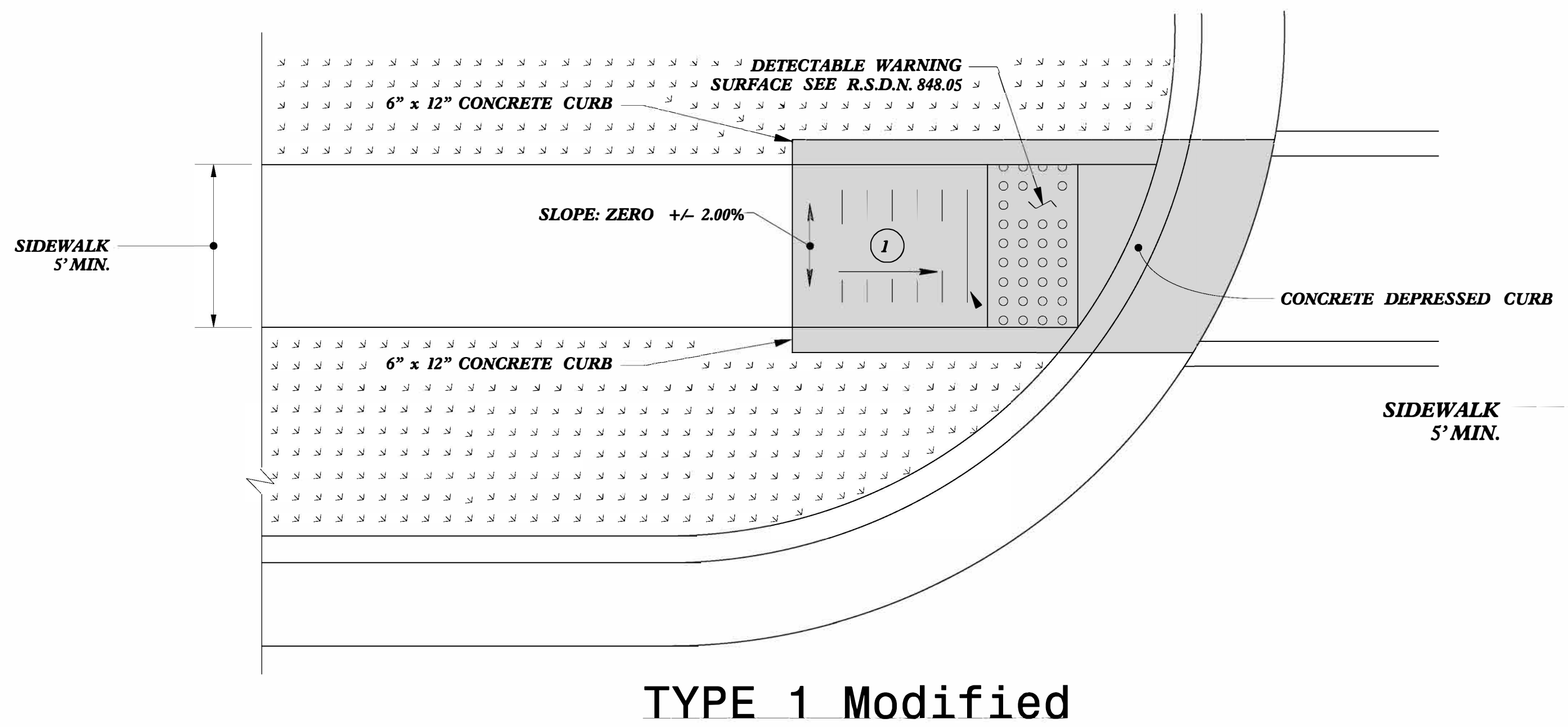
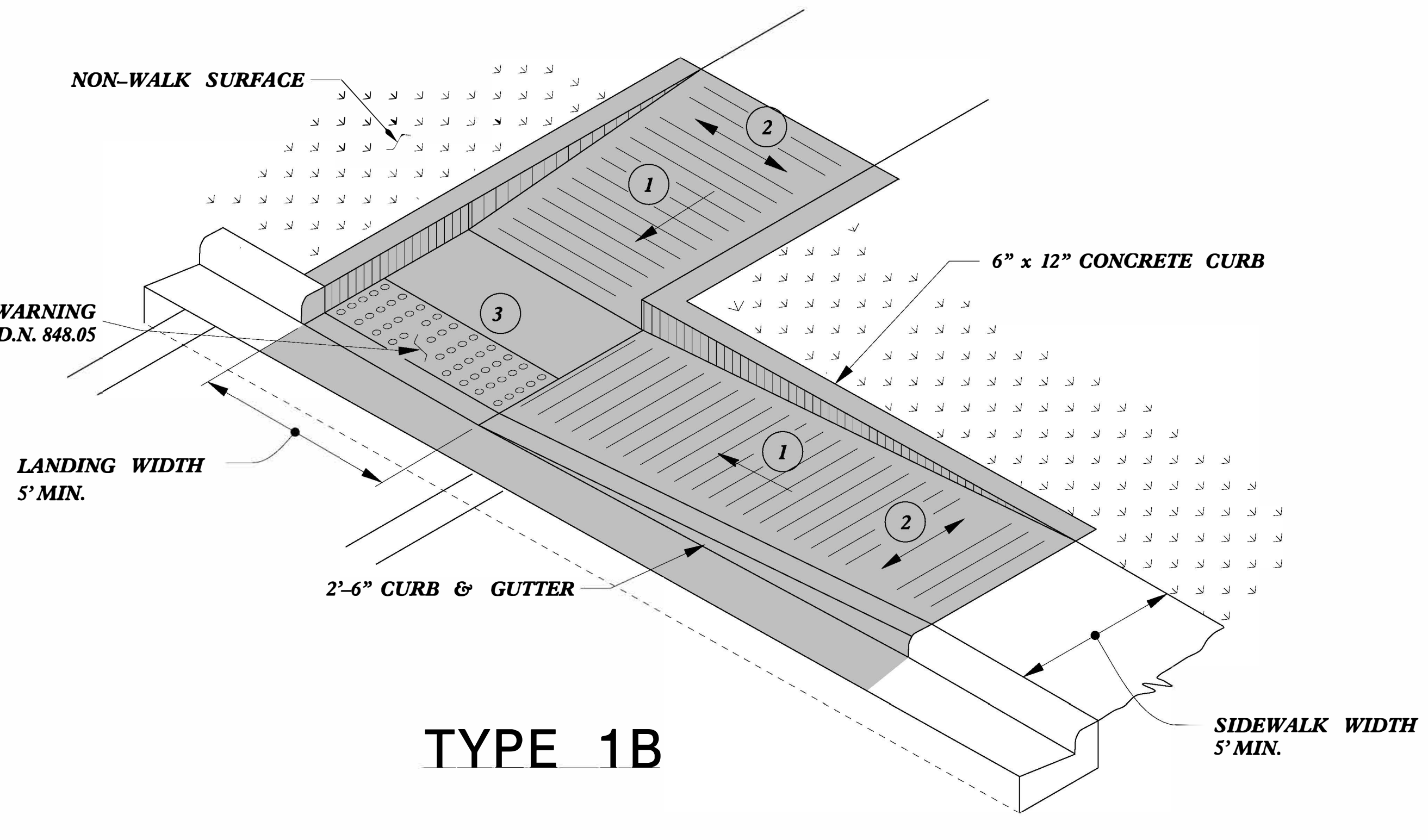
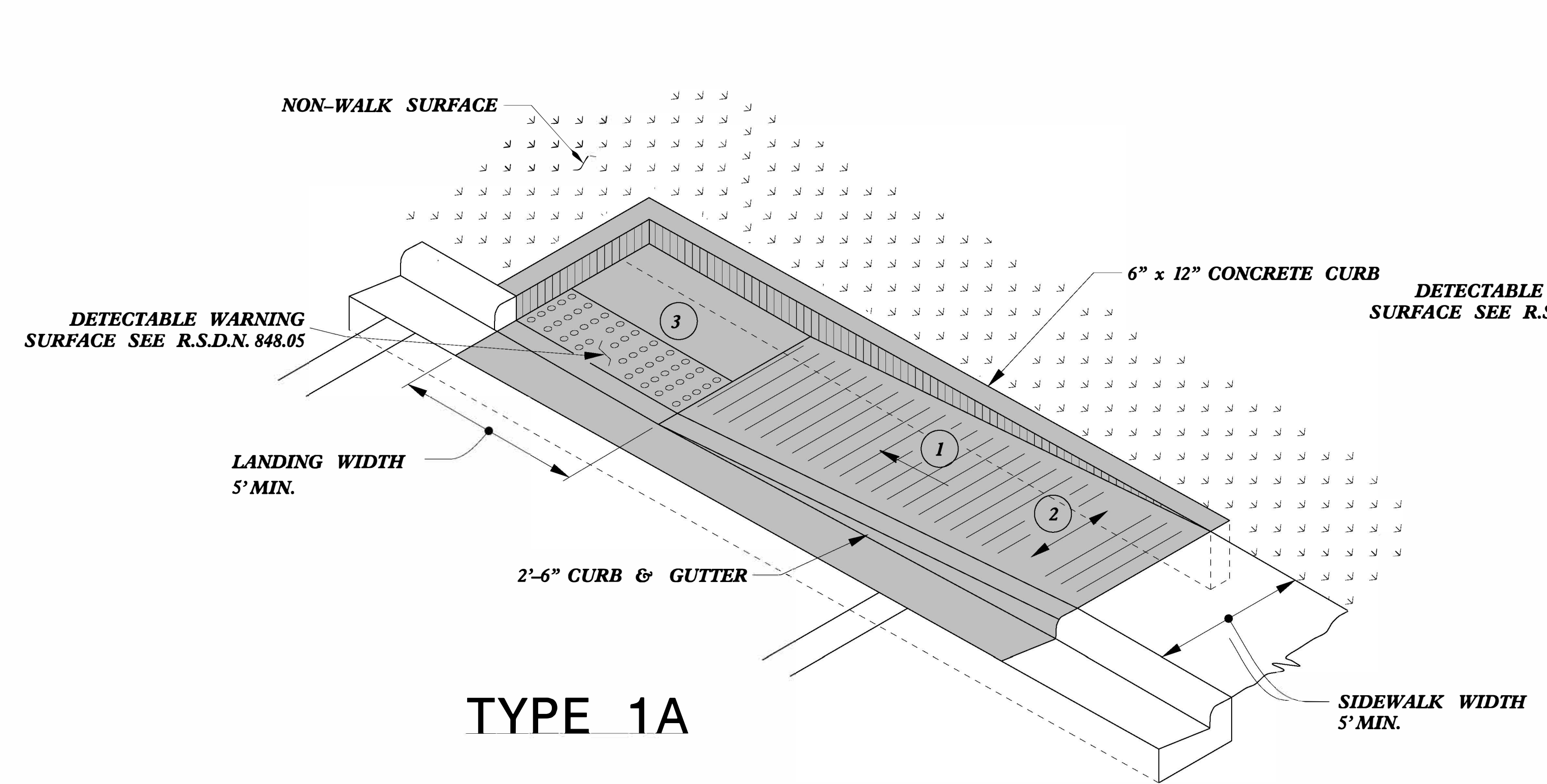

- 1 8.33% (12:1) MAX RAMP SLOPE
- 2 CROSS SLOPE: 2.00%
- 3 CURB RAMPS REQUIRE A (4'-0") MINIMUM LANDING WITH A MAXIMUM CROSS SLOPE AND LONGITUDINAL SLOPE OF 2.00% WHERE PEDESTRIANS PERFORM TURNING MANEUVERS. SLOPE TO DRAIN TO CURB.

PAY LIMITS FOR 1 CURB RAMP

REFER TO ROADWAY STANDARD DRAWING NUMBER 848.05 SHEET 3 OF 3 FOR ALL RAMP NOTES

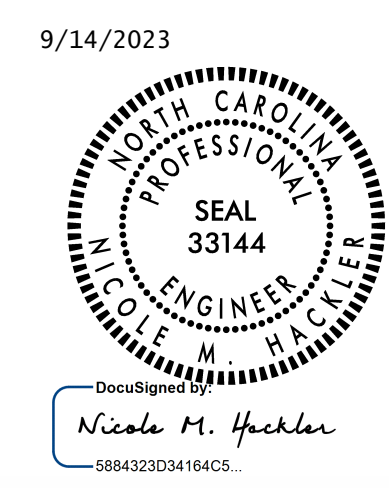

DOCUMENT NOT CONSIDERED FINAL  
UNLESS ALL SIGNATURES COMPLETED

**CONTRACT STANDARDS  
AND DEVELOPMENT UNIT**  
Office 919-707-6950 FAX 919-250-4119

**CURB RAMPS**  
Directional Ramps

ORIGINAL BY: J.S. HOWERTON DATE: 7/7/11  
 MODIFIED BY: \_\_\_\_\_ DATE: \_\_\_\_\_  
 CHECKED BY: \_\_\_\_\_ DATE: \_\_\_\_\_  
 FILE SPEC: stds/2012CurbRamp/CurbRampDetails.dgn

5/14/99



5/14/99

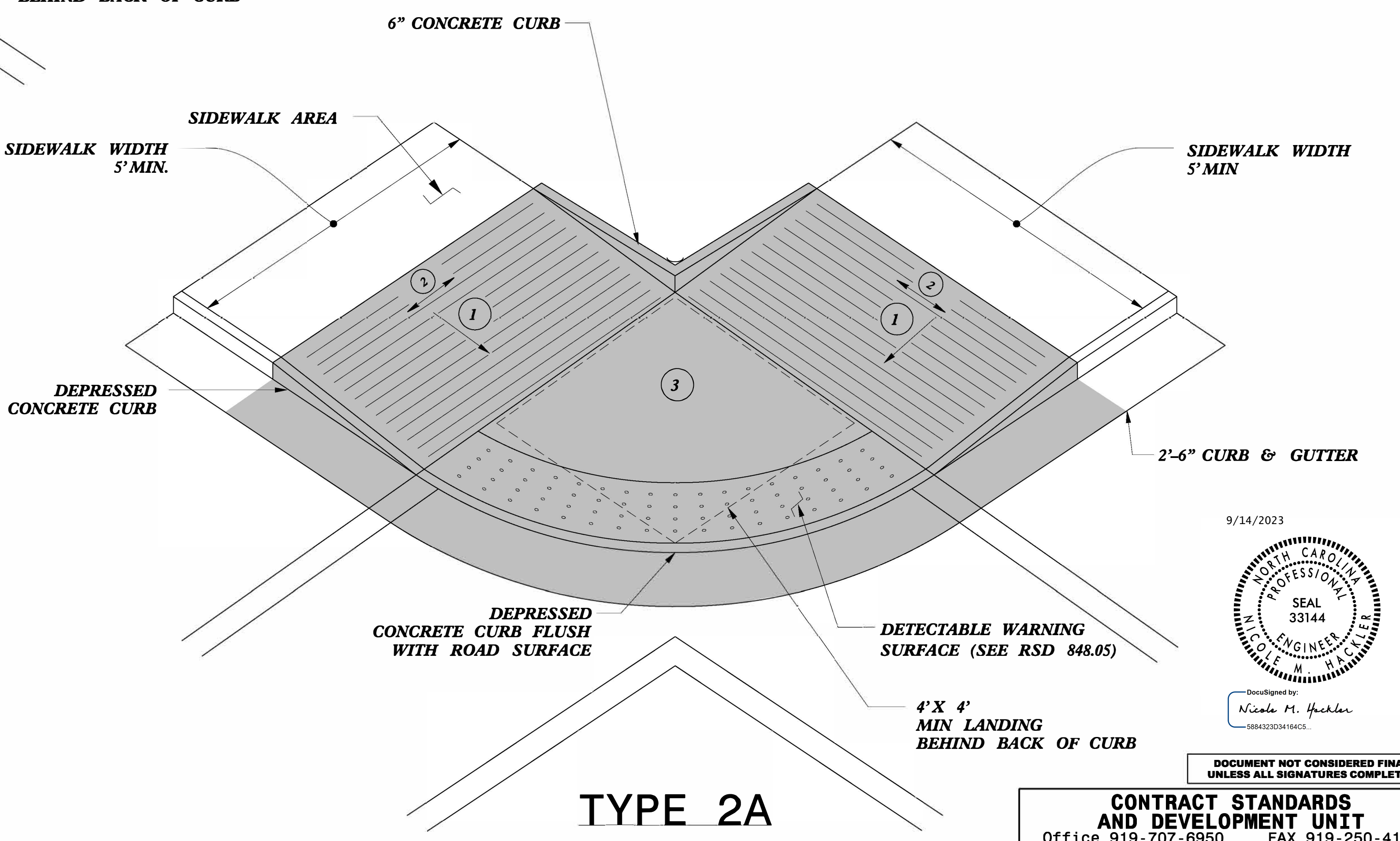
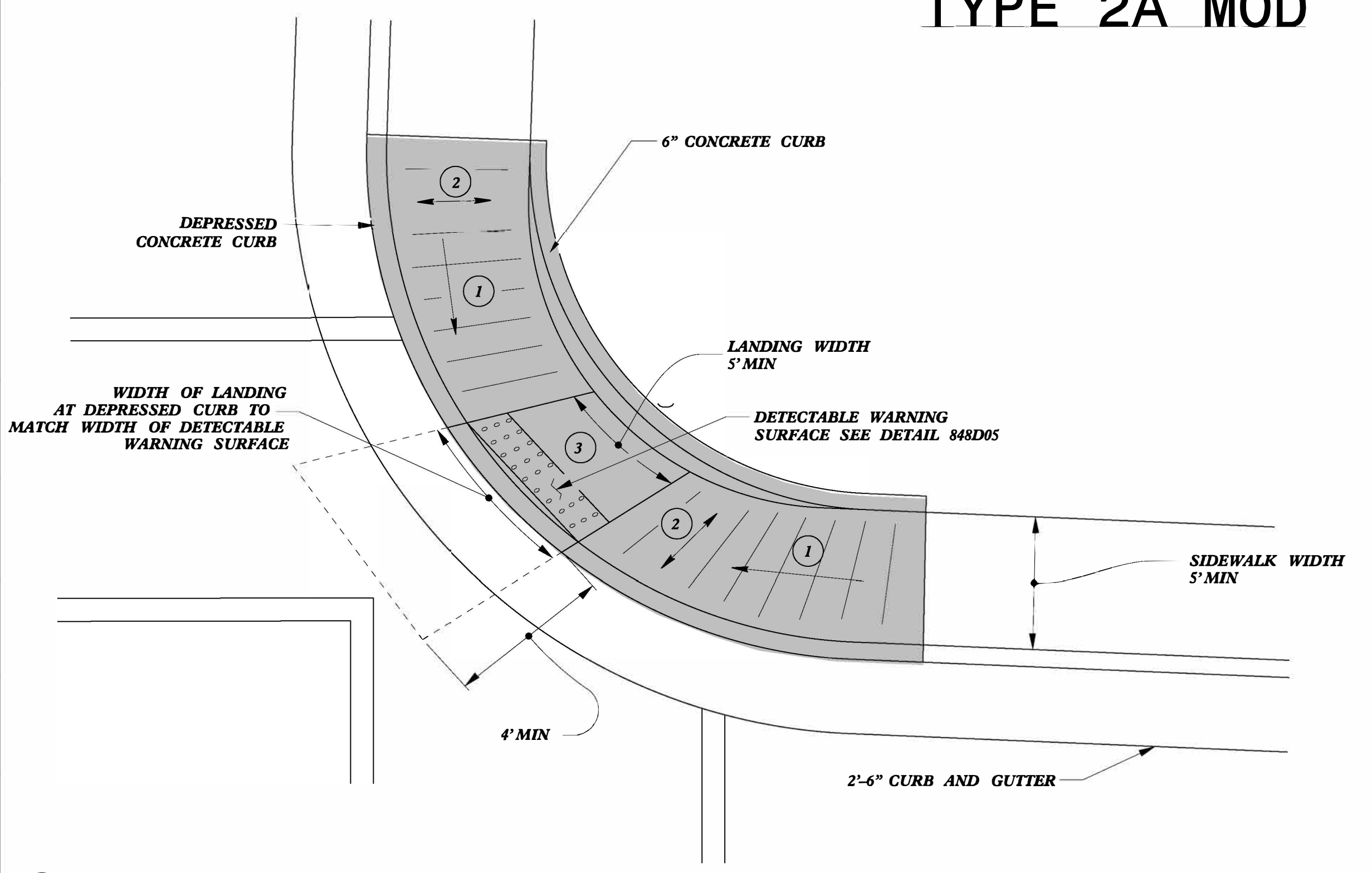
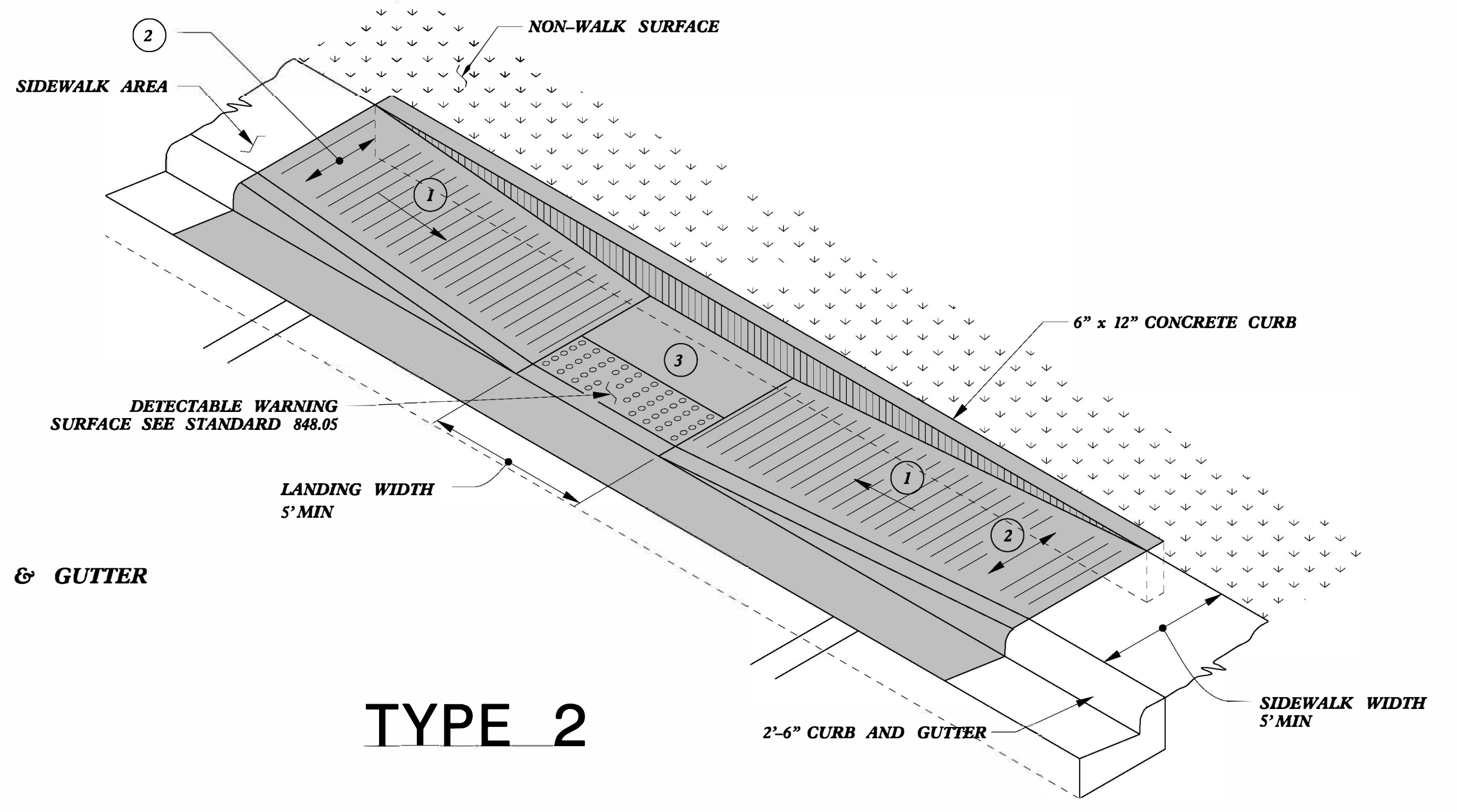
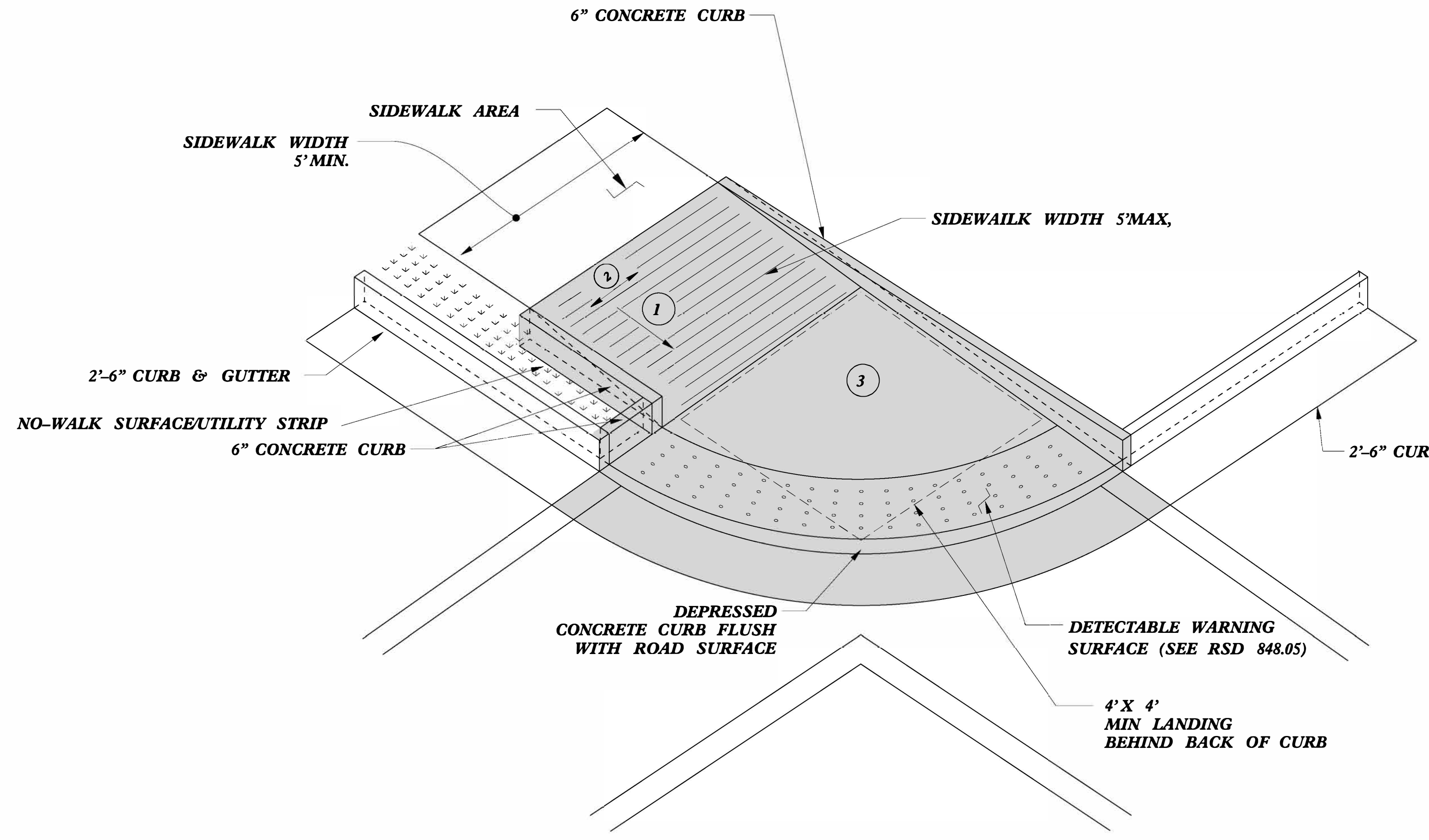

- 1 8.33% (12:1) MAX RAMP SLOPE
- 2 CROSS SLOPE: 2.00%
- 3 CURB RAMPS REQUIRE A (4'-0") MINIMUM LANDING WITH A MAXIMUM CROSS SLOPE AND LONGITUDINAL SLOPE OF 2.00% WHERE PEDESTRIANS PERFORM TURNING MANEUVERS. SLOPE TO DRAIN TO CURB.

PAY LIMITS FOR 1 CURB RAMP

9/14/2023

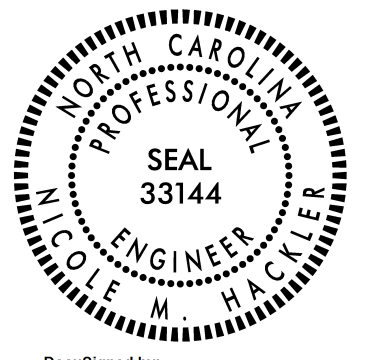

DocuSigned by:  
Nicole M. Hecker  
589432303416405

DOCUMENT NOT CONSIDERED FINAL UNLESS ALL SIGNATURES COMPLETED

**CONTRACT STANDARDS AND DEVELOPMENT UNIT**  
Office 919-707-6950 FAX 919-250-4119

### CURB RAMPS

ORIGINAL BY: J.S. HOWERTON DATE: 7/7/11  
 MODIFIED BY: DATE:  
 CHECKED BY: DATE:  
 FILE SPEC: stds/2012CurbRamp/CurbRampDetails.dgn



**PAY LIMITS FOR 1 CURB RAMP**

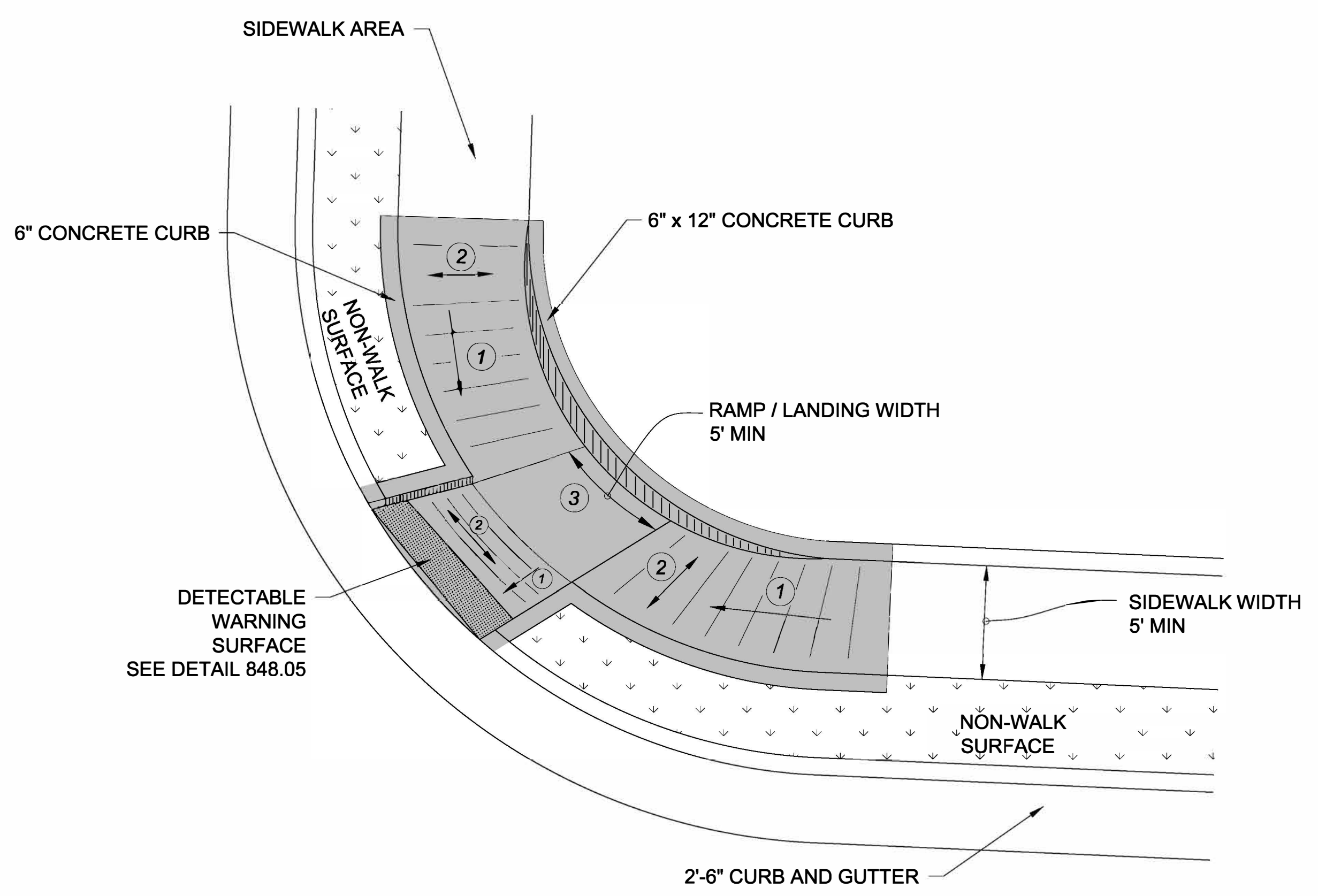

**TYPE 3 MODIFIED  
INSTALLATION IN A RADIUS**

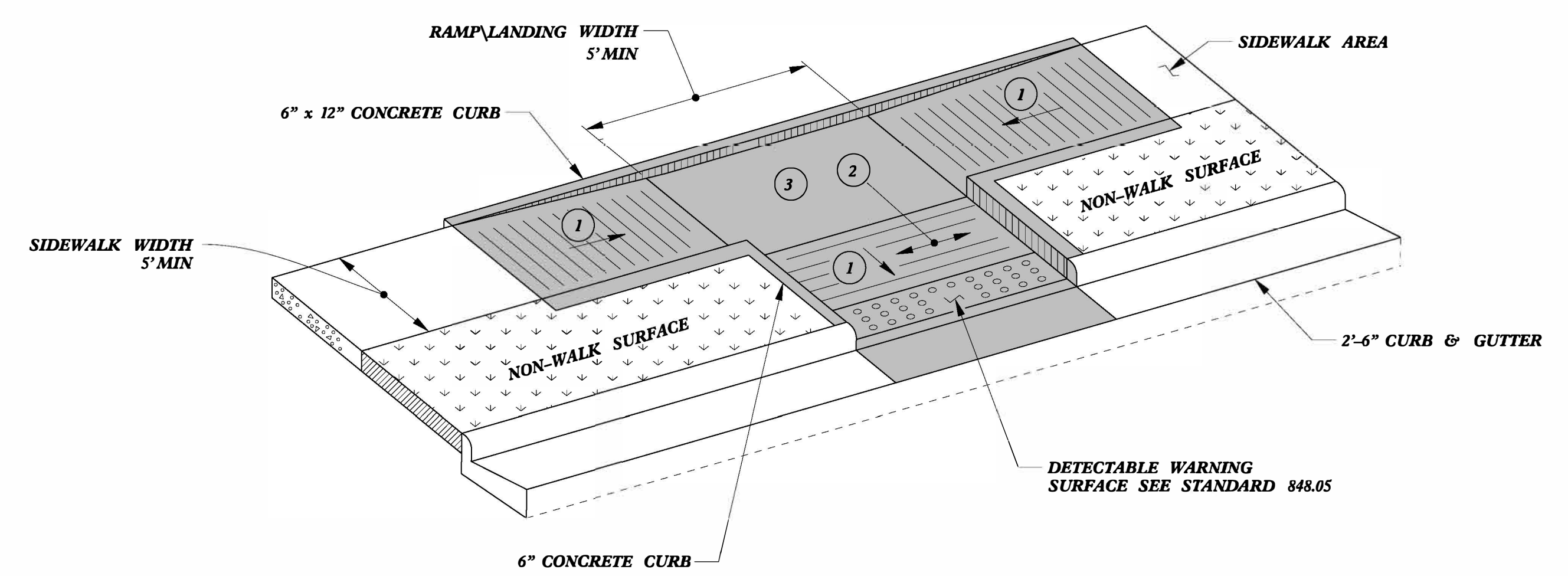

**TYPE 3**

- ① 8.33% (12:1) MAX RAMP SLOPE
- ② CROSS SLOPE: 2.00%
- ③ CURB RAMPS REQUIRE A (4'-0") MINIMUM LANDING WITH A MAXIMUM CROSS SLOPE AND LONGITUDINAL SLOPE OF 2.00% WHERE PEDESTRIANS PERFORM TURNING MANEUVERS. SLOPE TO DRAIN TO CURB.

9/14/2023

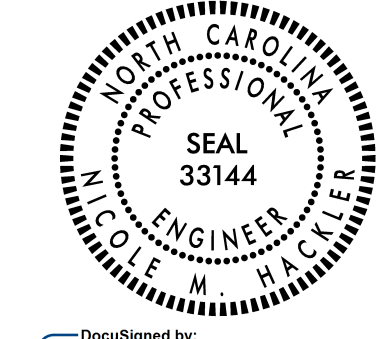

DocuSigned by:  
*Nicole M. Hecker*  
5884323034164C5...

DOCUMENT NOT CONSIDERED FINAL  
UNLESS ALL SIGNATURES COMPLETED

**CONTRACT STANDARDS  
AND DEVELOPMENT UNIT**  
Office 919-707-6950 FAX 919-250-4119

**CURB RAMPS**

ORIGINAL BY: J.S. HOWERTON DATE: 7/7/11  
 MODIFIED BY: \_\_\_\_\_ DATE: \_\_\_\_\_  
 CHECKED BY: \_\_\_\_\_ DATE: \_\_\_\_\_  
 FILE SPEC: stds/2012CurbRamp/CurbRampDetails.dgn

5/14/99



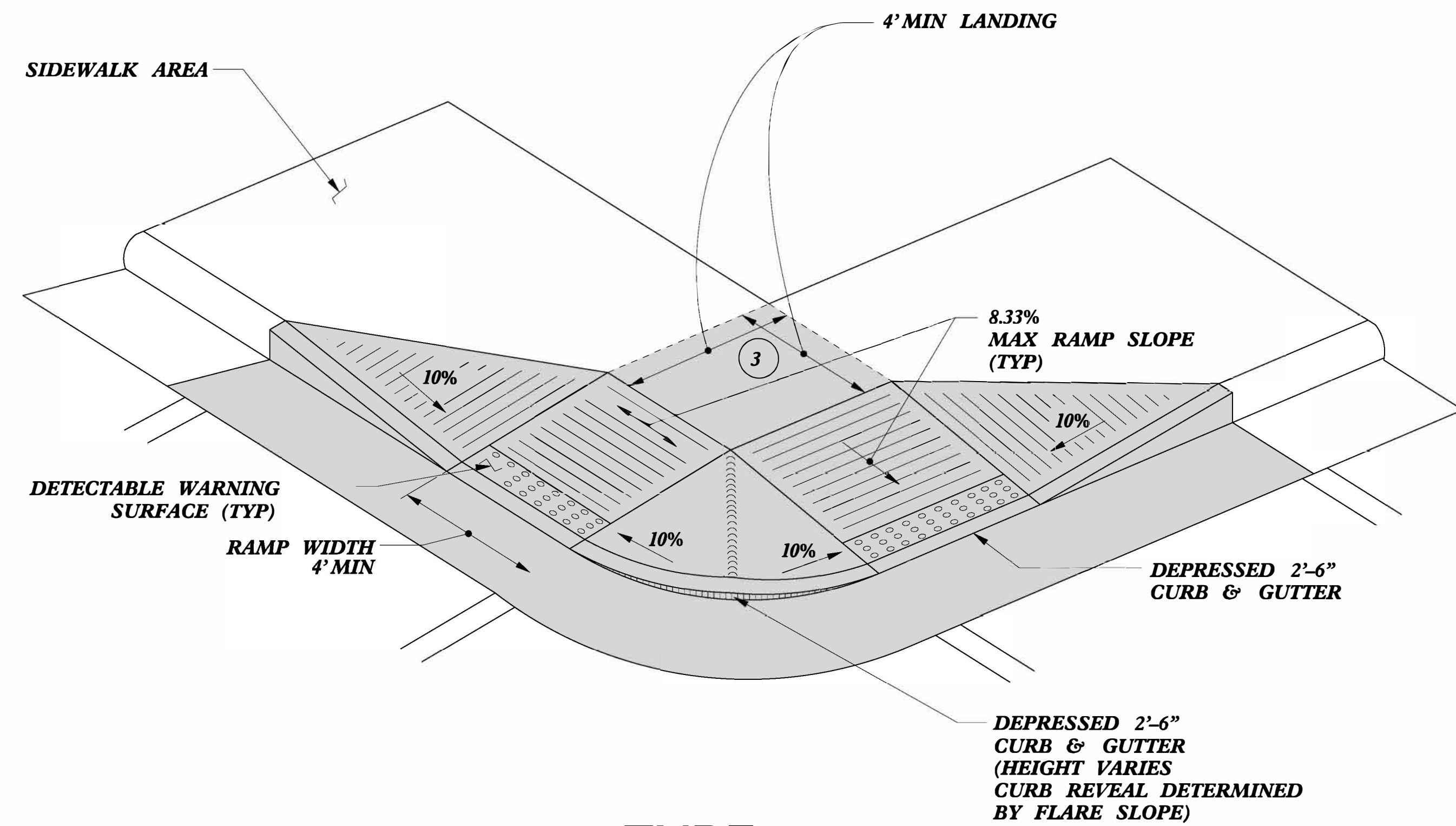

TYPE 4

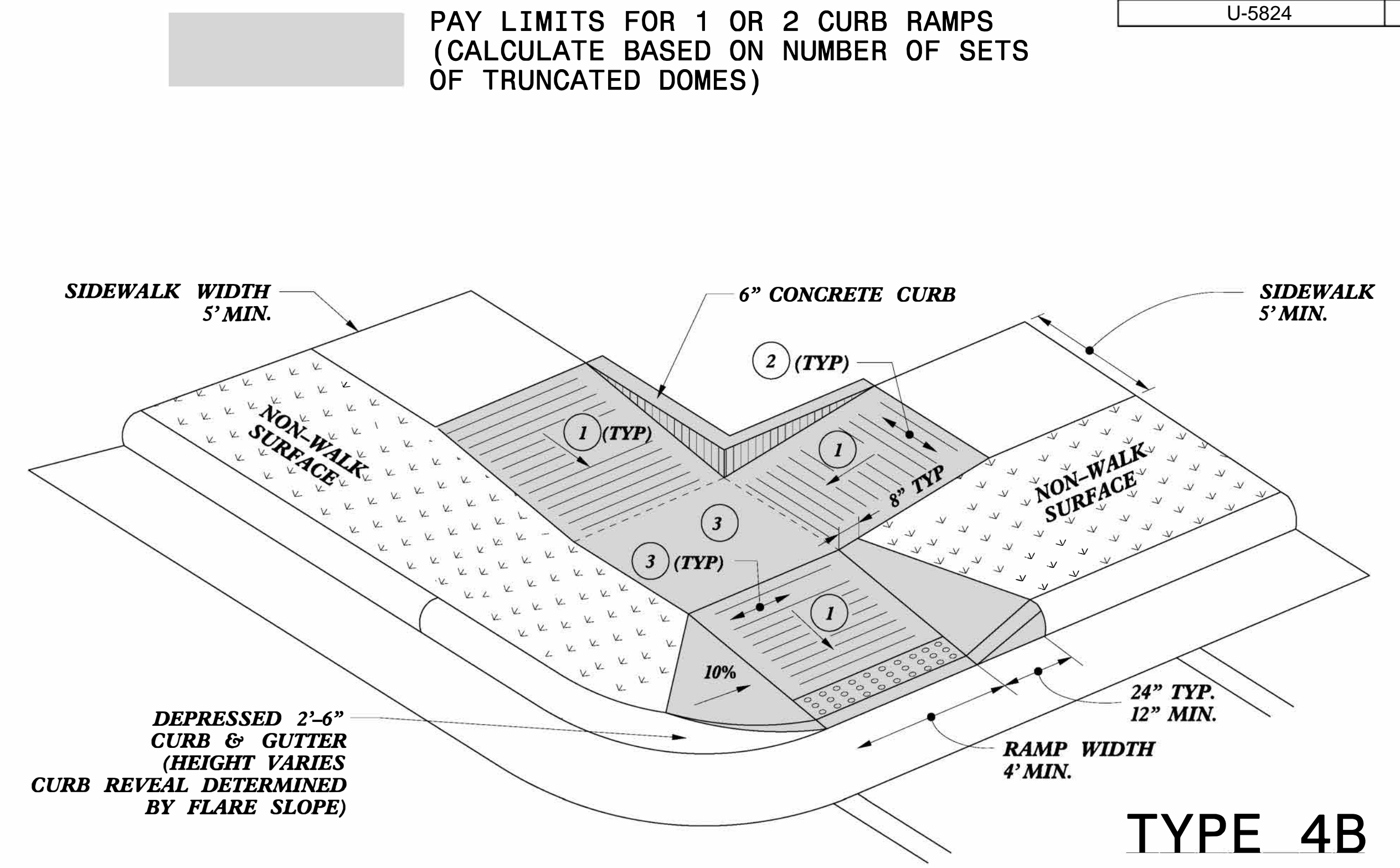

TYPE 4B

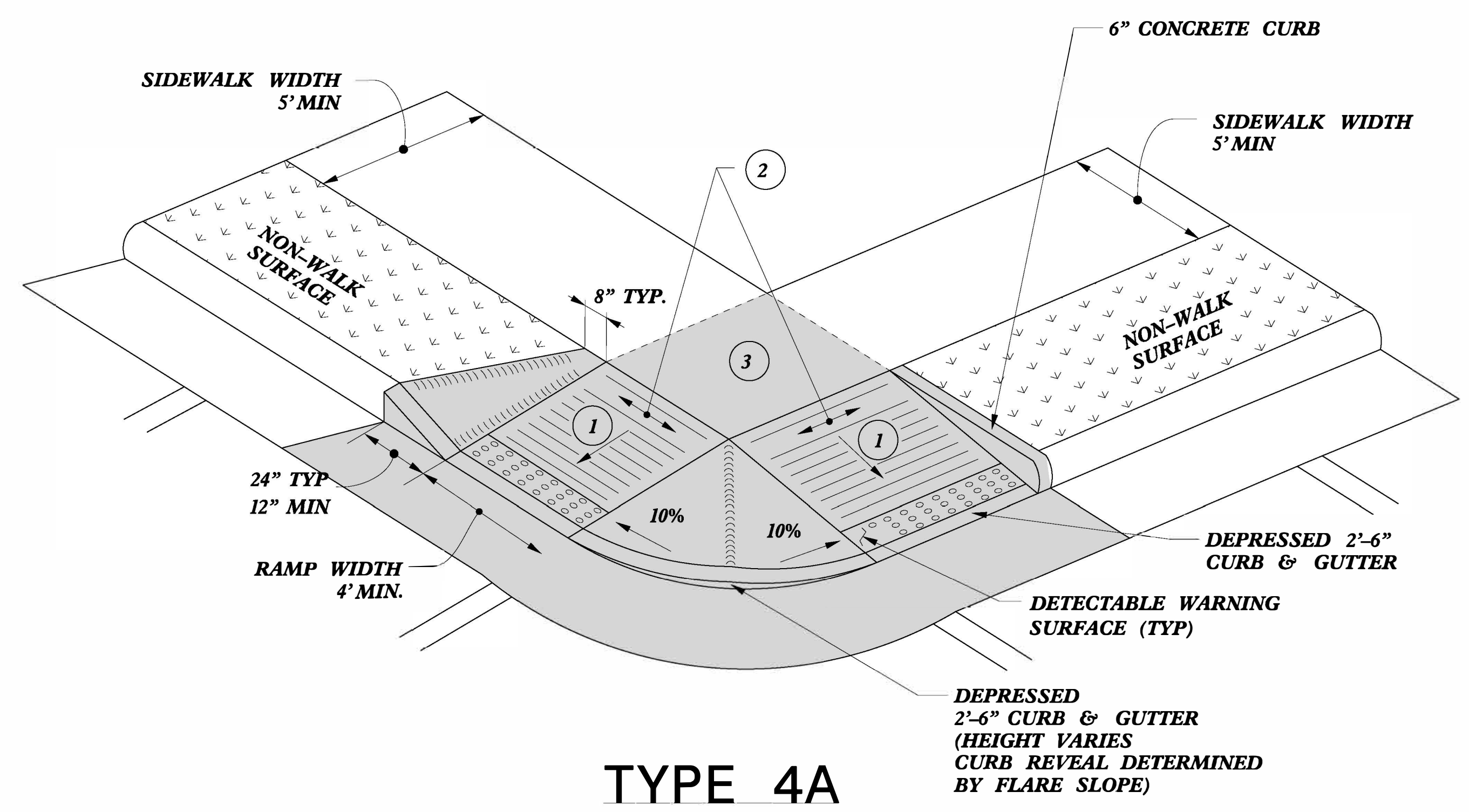

TYPE 4A

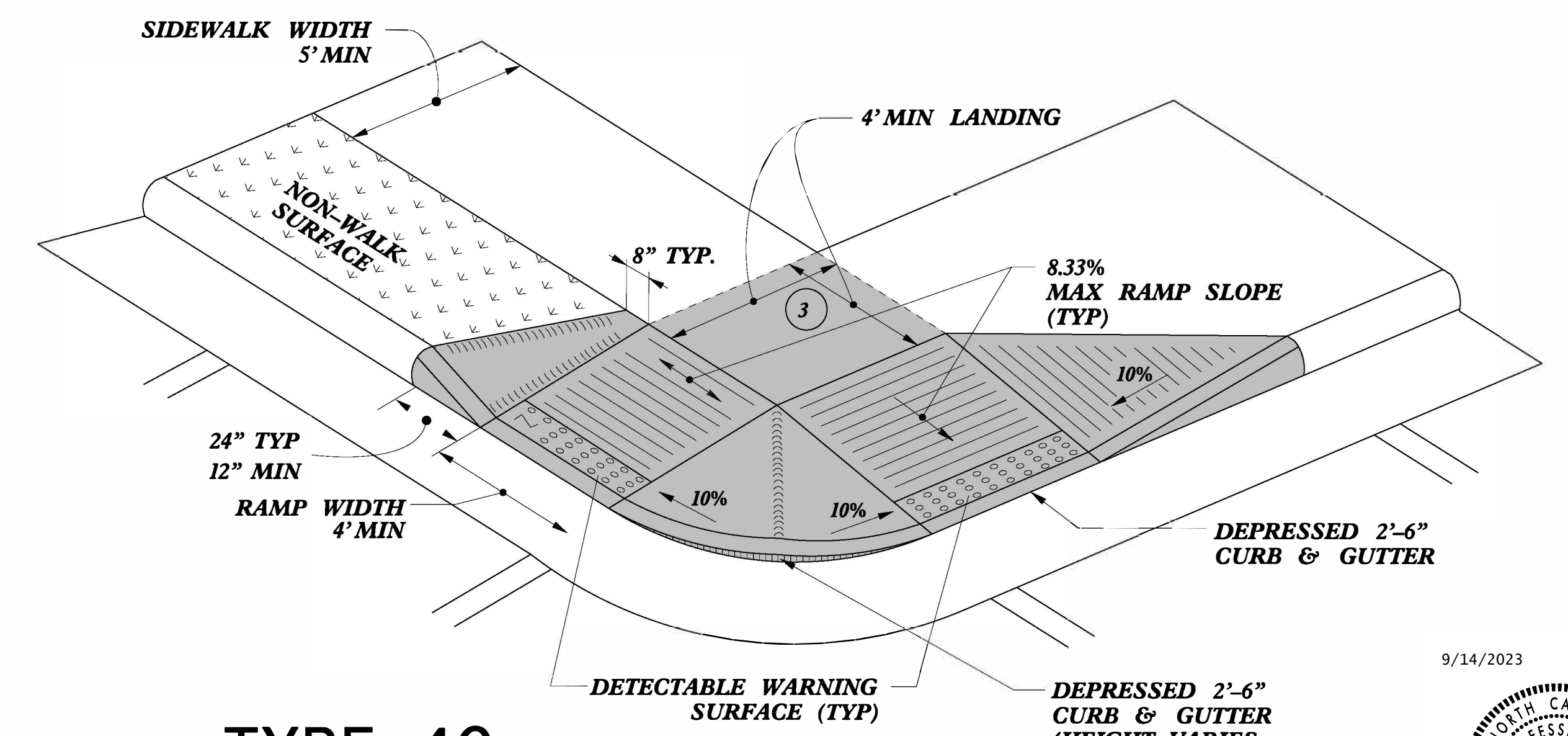

TYPE 4C

- 1 8.33% (12:1) MAX RAMP SLOPE
- 2 CROSS SLOPE: 2.00%
- 3 CURB RAMPS REQUIRE A (4'-0") MINIMUM LANDING WITH A MAXIMUM CROSS SLOPE AND LONGITUDINAL SLOPE OF 2.00% WHERE PEDESTRIANS PERFORM TURNING MANEUVERS. SLOPE TO DRAIN TO CURB.

9/14/2023

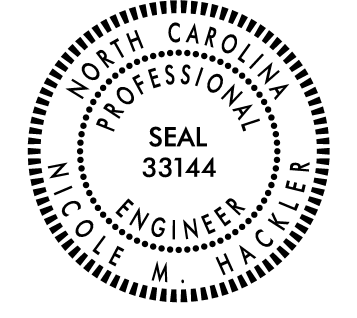

DocuSigned by: Nicole M. Hecker 5884323D34164C5

DOCUMENT NOT CONSIDERED FINAL UNLESS ALL SIGNATURES COMPLETED

**CONTRACT STANDARDS AND DEVELOPMENT UNIT**  
 Office 919-707-6950 FAX 919-250-4119

**CURB RAMPS**

ORIGINAL BY: J.S. HOWERTON DATE: 7/7/11  
 MODIFIED BY: DATE:  
 CHECKED BY: DATE:  
 FILE SPEC. stds/2012CurbRamp/CurbRampDetails.dgn

REFER TO ROADWAY STANDARD DRAWING NUMBER 848.05 SHEET 3 OF 3 FOR ALL RAMP NOTES

5/14/99  
C:\TEMP\6655\DWG\848.05\848.05-3.dwg  
PLOT DATE: 9/14/2023 10:58:14 AM  
PLOT BY: J.S. HOWERTON



5/14/99

**PAY LIMITS FOR 1 OR 2 CURB RAMPS**  
 (CALCULATE BASED ON NUMBER OF SETS  
 OF TRUNCATED DOMES)

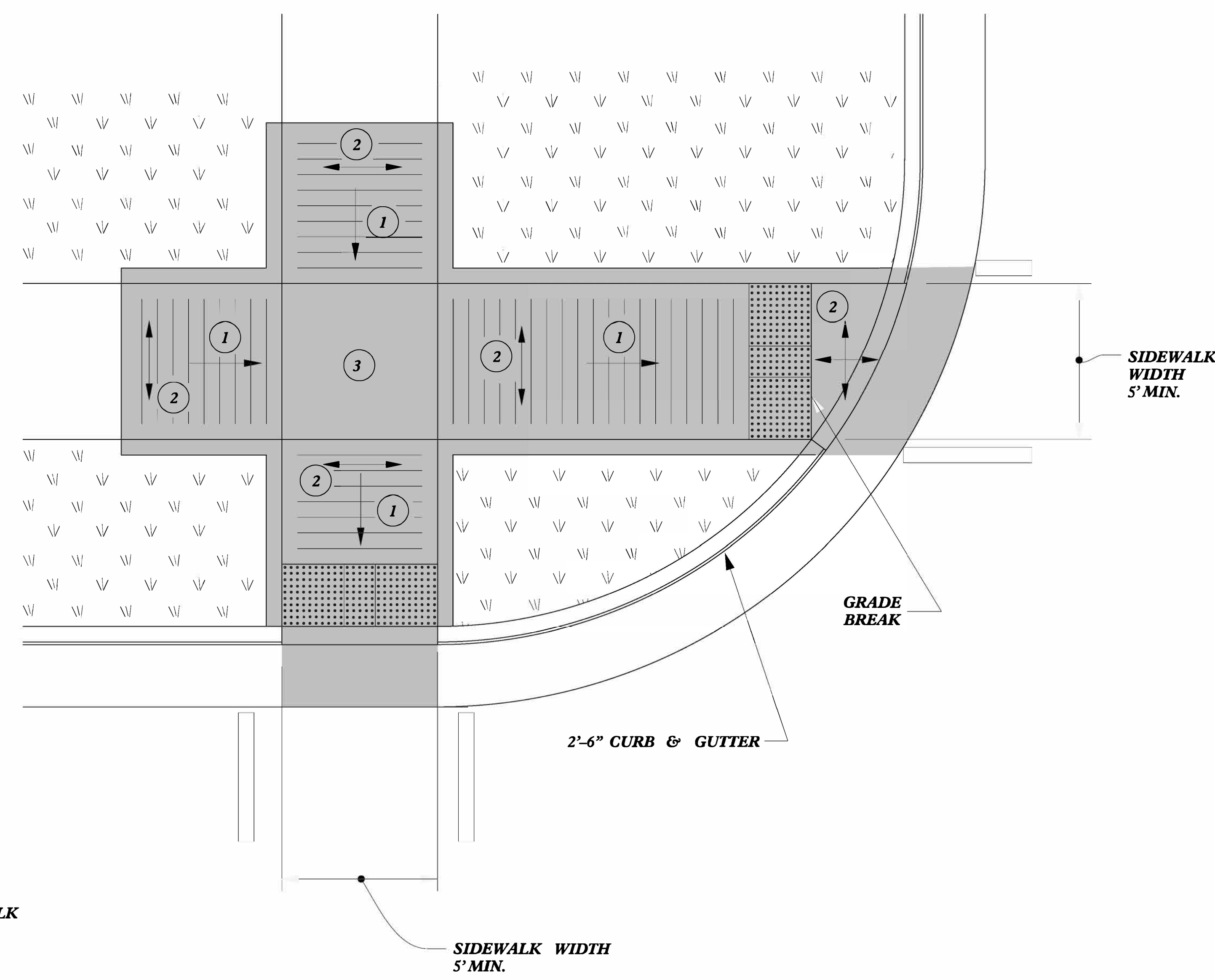

**TYPE 5A**

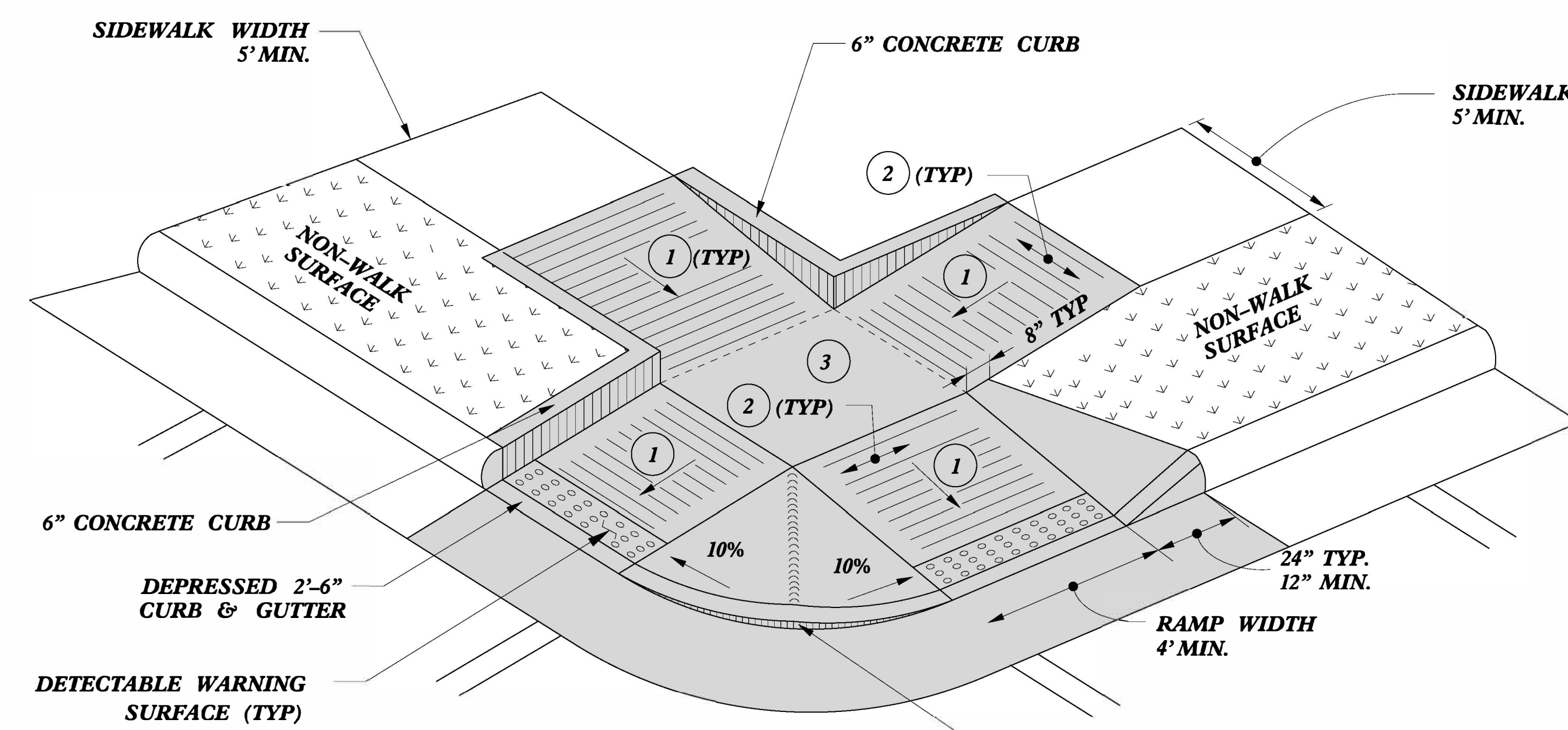

**TYPE 5**

- 1 8.33% (12:1) MAX RAMP SLOPE
- 2 CROSS SLOPE: 2.00%
- 3 CURB RAMPS REQUIRE A (4'-0") MINIMUM LANDING WITH A MAXIMUM CROSS SLOPE AND LONGITUDINAL SLOPE OF 2.00% WHERE PEDESTRIANS PERFORM TURNING MANEUVERS. SLOPE TO DRAIN TO CURB.

9/14/2023

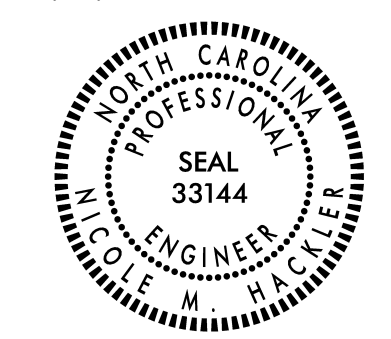

DocuSigned by:  
Nicole M. Hecker  
588432034164C5...

**CONTRACT STANDARDS  
 AND DEVELOPMENT UNIT**  
 Office 919-707-6950 FAX 919-250-4119

**CURB RAMPS**

ORIGINAL BY: J.S. HOWERTON DATE: 7/7/11  
 MODIFIED BY: \_\_\_\_\_ DATE: \_\_\_\_\_  
 CHECKED BY: \_\_\_\_\_ DATE: \_\_\_\_\_  
 FILE SPEC: stds/2012CurbRamp/CurbRampDetails.dgn

REFER TO ROADWAY STANDARD DRAWING NUMBER 848.05 SHEET 3 OF 3 FOR ALL RAMP NOTES

SYTIME\$\$\$\$  
DUCONS\$\$\$\$  
SUGERNAVE\$\$\$\$



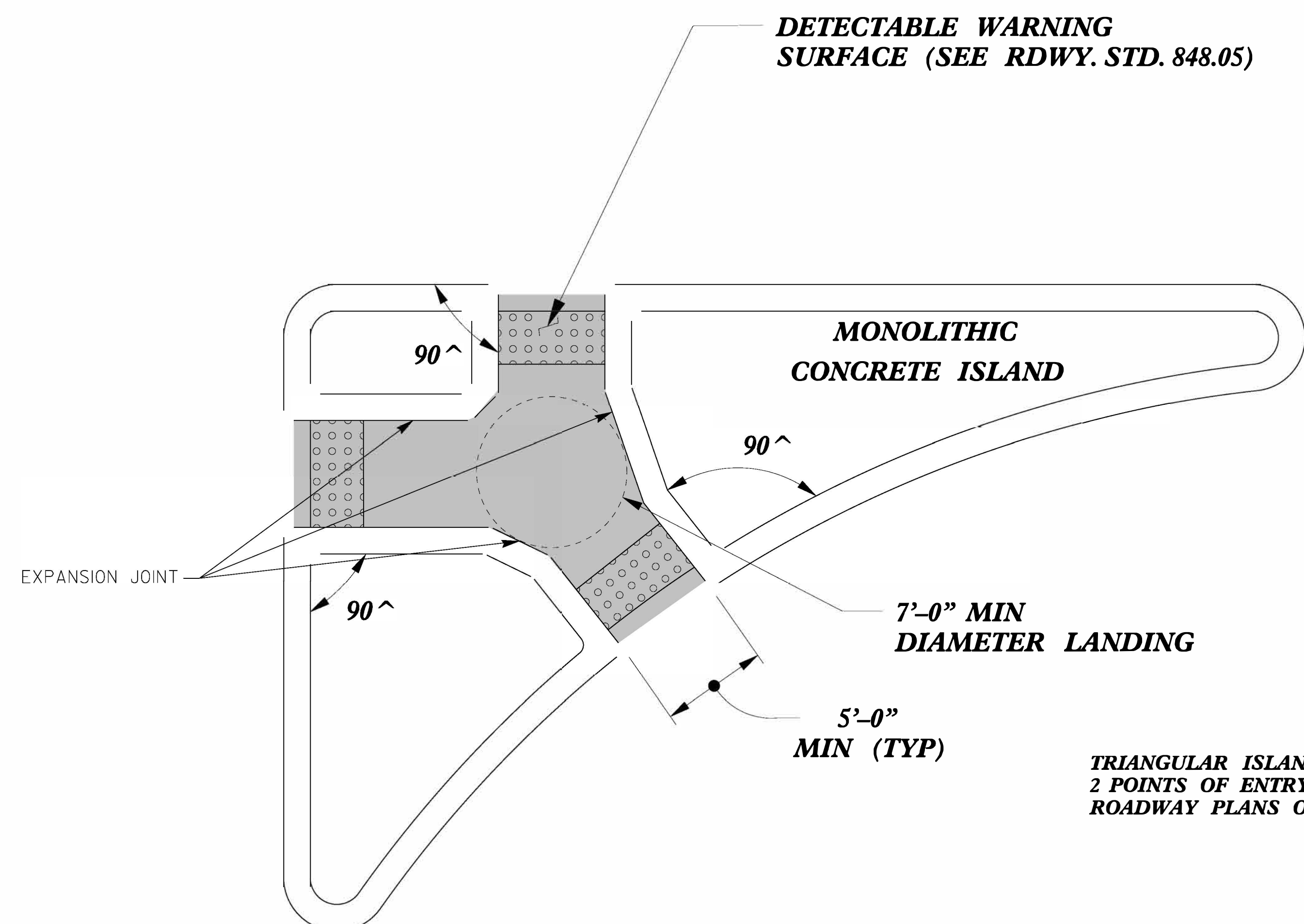

**PAY LIMITS FOR 2 OR 3 CURB RAMPS (CALCULATE BASED ON NUMBER OF SETS OF TRUNCATED DOMES)**

**TRIANGULAR ISLAND WITH CUT THROUGH**  
**TYPE 6**

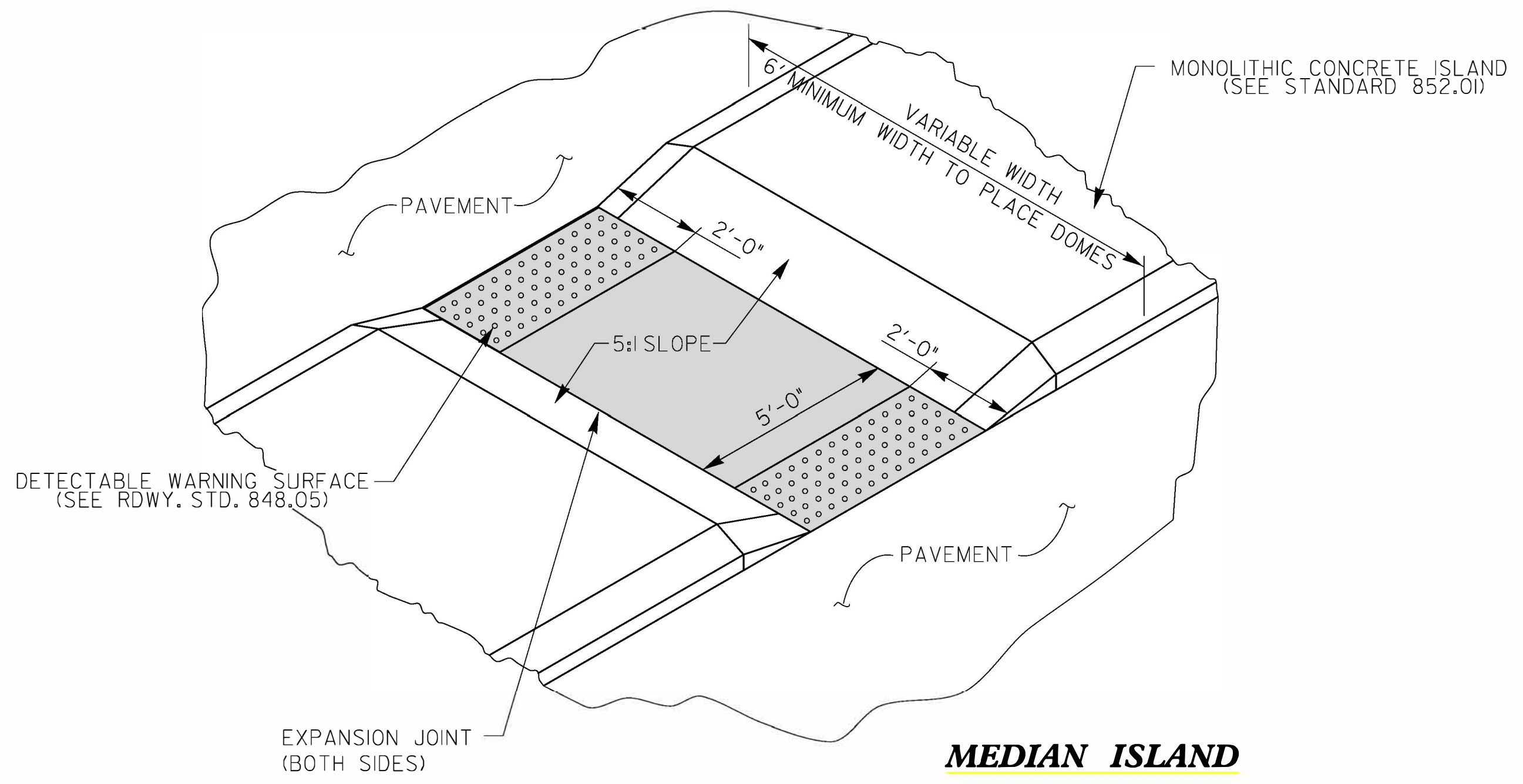

**MEDIAN ISLAND WITH CUT THROUGH**  
**TYPE 7**

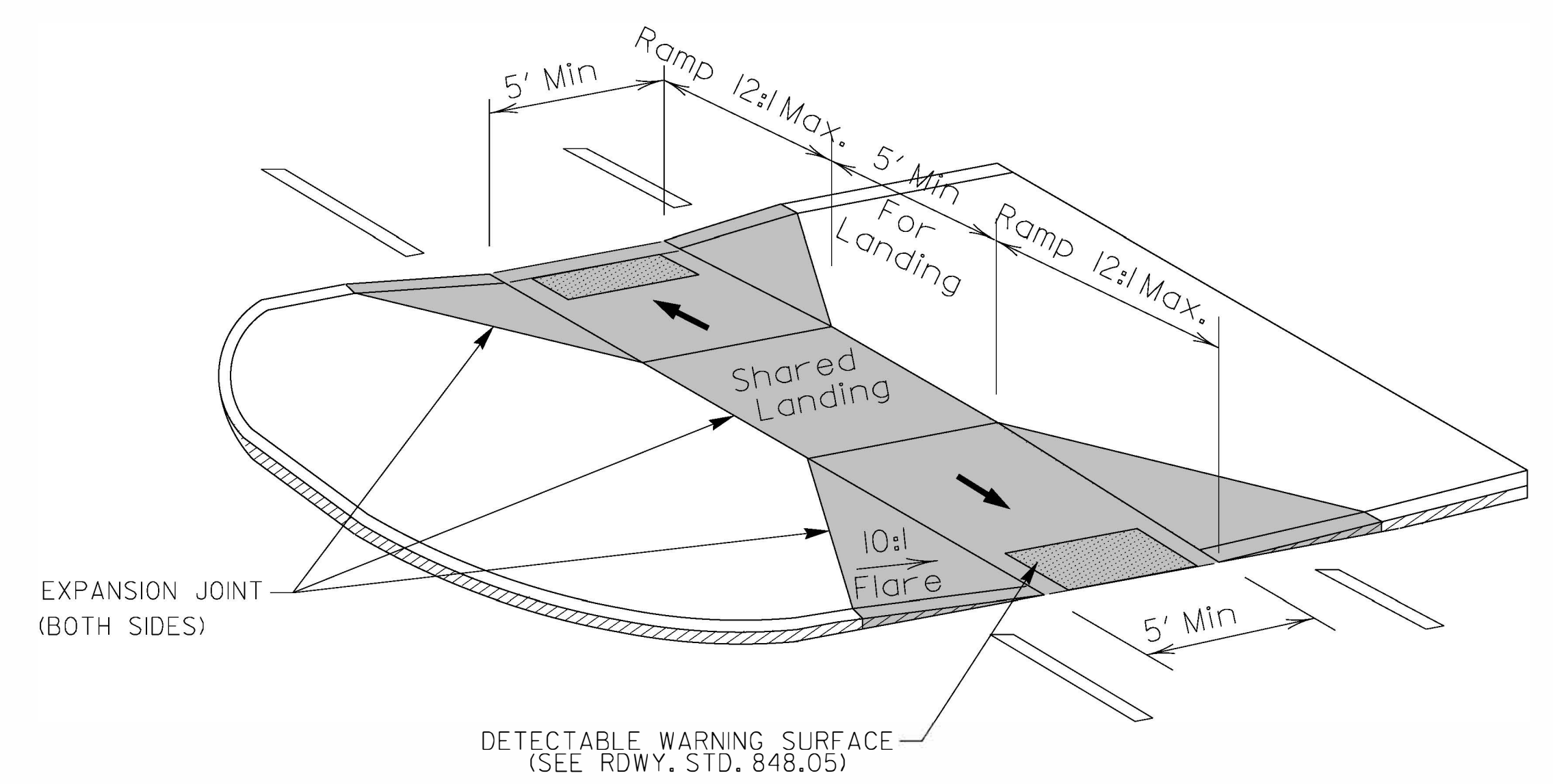

**MEDIAN ISLAND CURB RAMPS**  
**TYPE 8**

DOCUMENT NOT CONSIDERED FINAL UNLESS ALL SIGNATURES COMPLETED

**CONTRACT STANDARDS AND DEVELOPMENT UNIT**  
Office 919-707-6950 FAX 919-250-4119

**CURB RAMPS**  
Median or Turn Lane Islands

ORIGINAL BY: J.S. HOWERTON DATE: 7/7/11  
MODIFIED BY: DATE:  
CHECKED BY: DATE:  
FILE SPEC. stds/2012CurbRamp/CurbRampDetails.dgn

9/14/2023  
NORTH CAROLINA PROFESSIONAL ENGINEER SEAL 33144  
Nicole M. Hecker  
588423234164C9

5/14/99  
CYCLING  
SUGGESTIONS



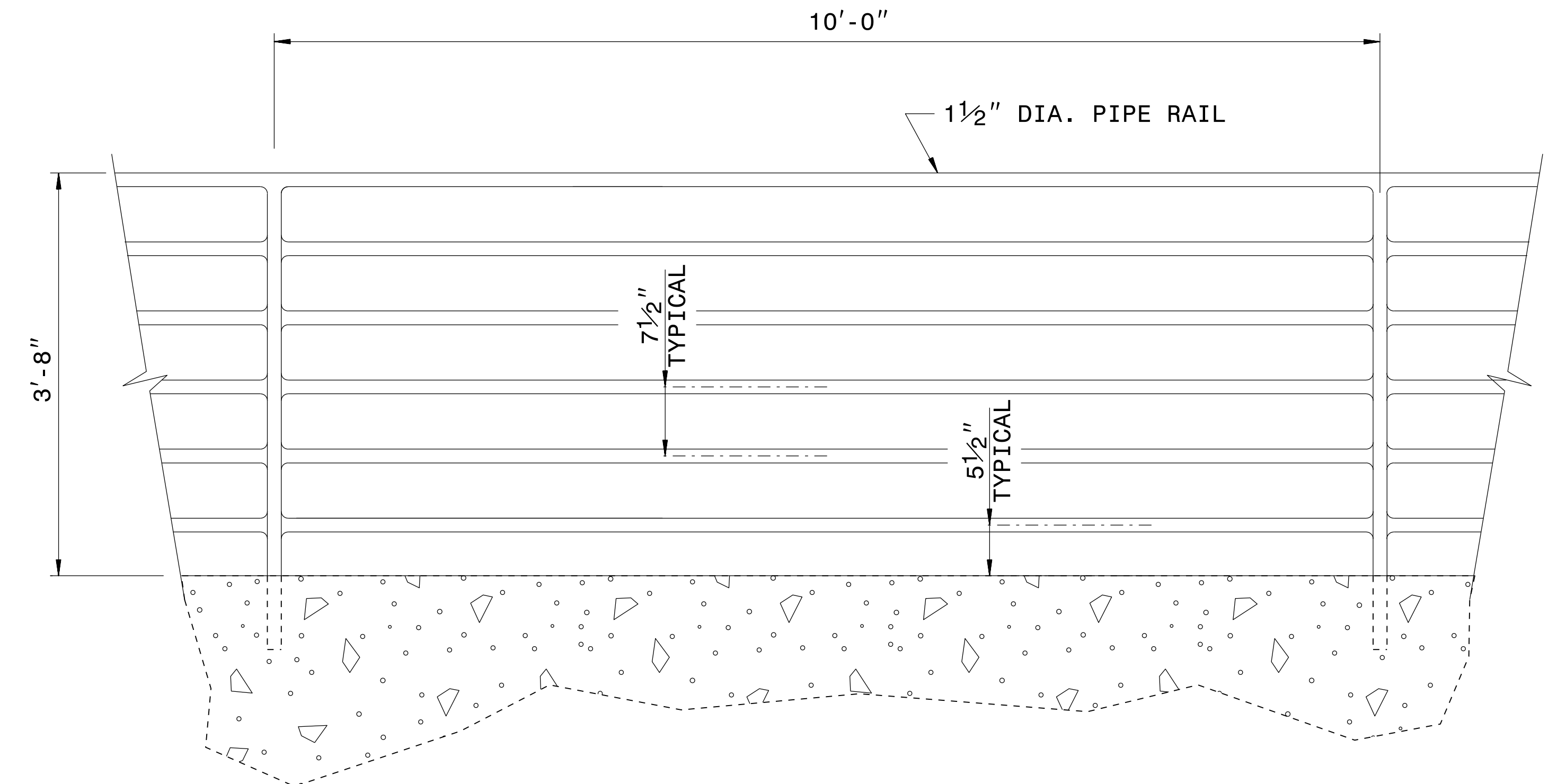

**ELEVATION OF HANDRAIL**

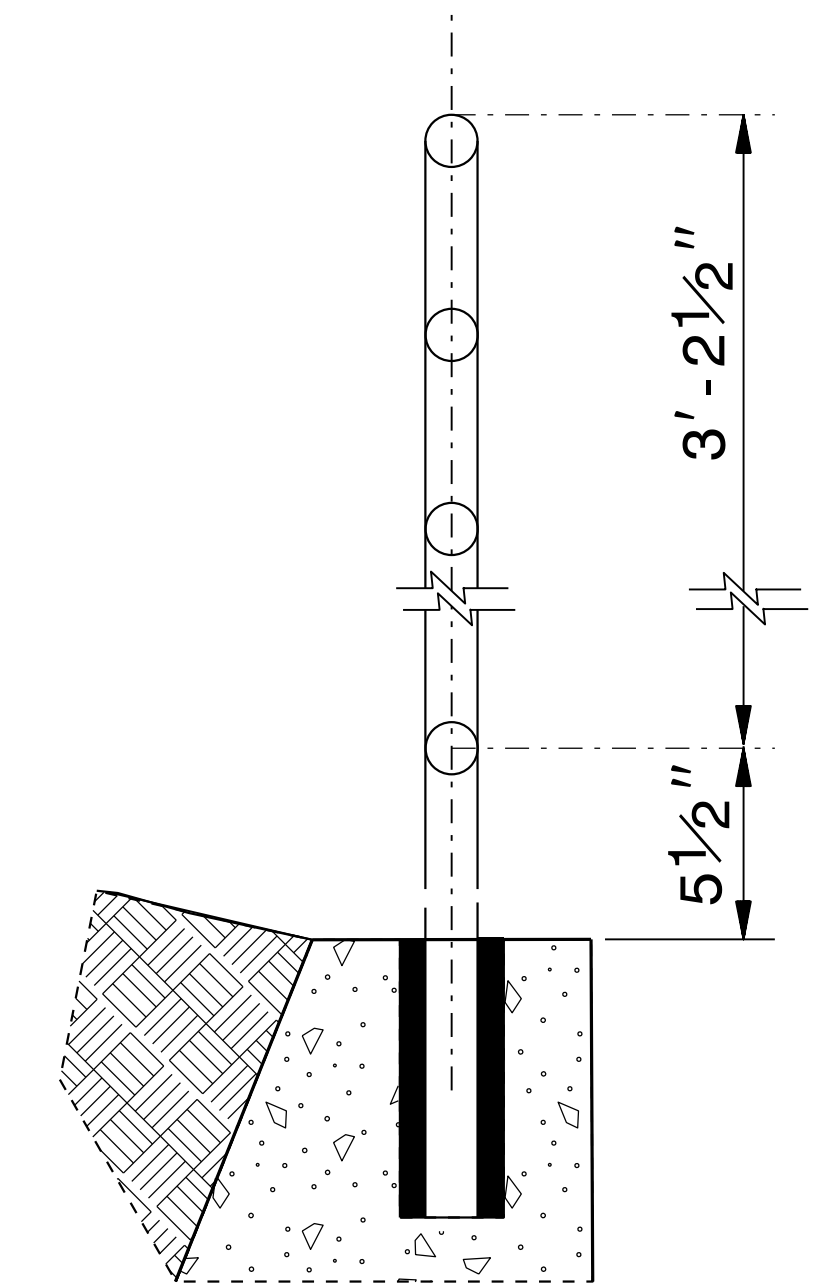

**INSET 'A'**

**NOTES:**

- CONSTRUCT PROPOSED STEEL PIPE RAIL 1 1/2" DIAMETER SCHEDULE 40 PLAIN END GALVANIZED STEEL PIPE MEETING THE REQUIREMENTS OF ASTM A53.
- EMBED PIPE RAIL INTO PROPOSED WALL WITH CHEMICAL OR CONCRETE GROUT ANCHORING SYSTEM PER THE WALL MANUFACTURER'S RECOMMENDATIONS.
- REPAIR GALVANIZING IN ACCORDANCE WITH SECTION 1076 OF THE NCDOT STANDARD SPECIFICATIONS.
- PAINT, IF REQUIRED BY THE ENGINEER, IN ACCORDANCE WITH SECTION 1080 OF THE STANDARD SPECIFICATIONS.
- CENTER THE PROPOSED RAILING ON TOP OF THE WALL WITH POST SPACING SYMMETRICAL ABOUT THE CENTER-LINE OF THE WALL.
- WELD IN ACCORDANCE WITH ARTICLE 1072-18 OF THE STANDARD SPECIFICATIONS.
- SUBMIT THE ATTACHMENT OF THE HANDRAIL TO THE RETAINING WALL TO THE CONTRACTS AND STANDARDS OFFICE FOR APPROVAL.

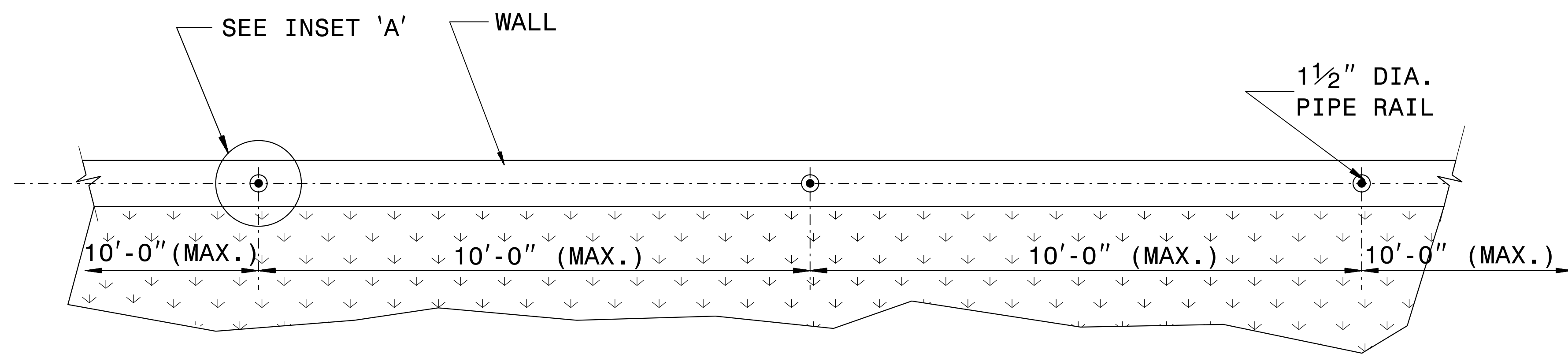

**PLAN VIEW**

24-MAY-2018 14:10 S:\Contracts\Special Details\Jhowerton\Handrail on Retaining Wall.dgn Jhowerton AT USD-292595

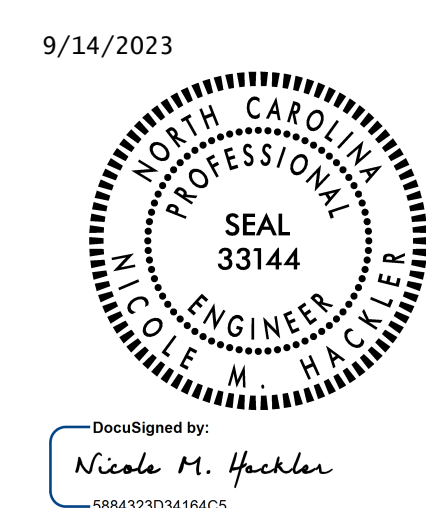

DOCUMENT NOT CONSIDERED FINAL  
UNLESS ALL SIGNATURES COMPLETED

**CONTRACT STANDARDS  
AND DEVELOPMENT UNIT**  
Office 919-707-6950 FAX 919-250-4119

**DETAIL OF PIPE HANDRAIL  
MOUNTED ON A WALL**

ORIGINAL BY: E.E. WARD	DATE: 12-99
MODIFIED BY:	DATE:
CHECKED BY:	DATE:
FILE SPEC.: jhowerton/handrail_on_retaining_wall.dgn	

16-APR-2018 11:44  
 S:\Contracts\Special Details\Jhewerton\840d02 Extra Depth CB.dgn  
 Jhewerton AT CSD-292595

5/14/99

STATE OF NORTH CAROLINA  
 DEPT. OF TRANSPORTATION  
 DIVISION OF HIGHWAYS  
 RALEIGH, N.C.

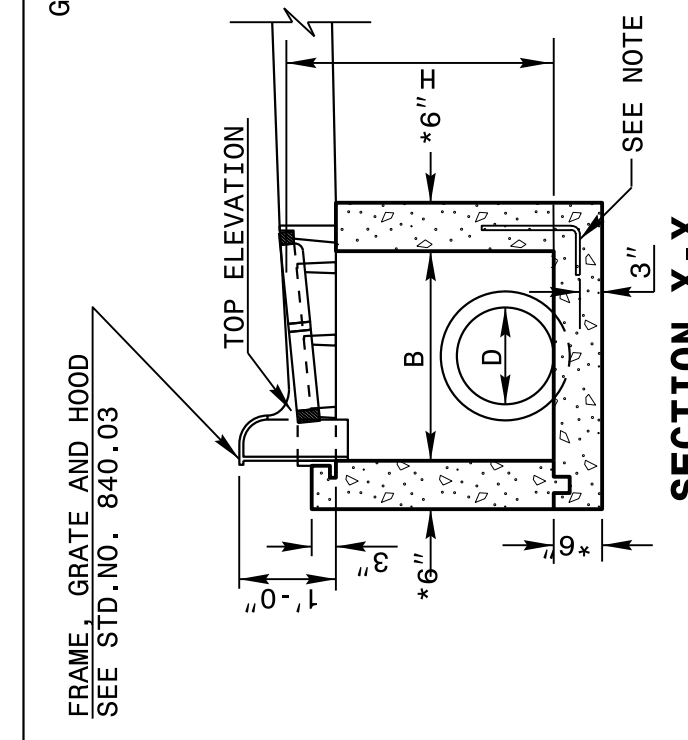
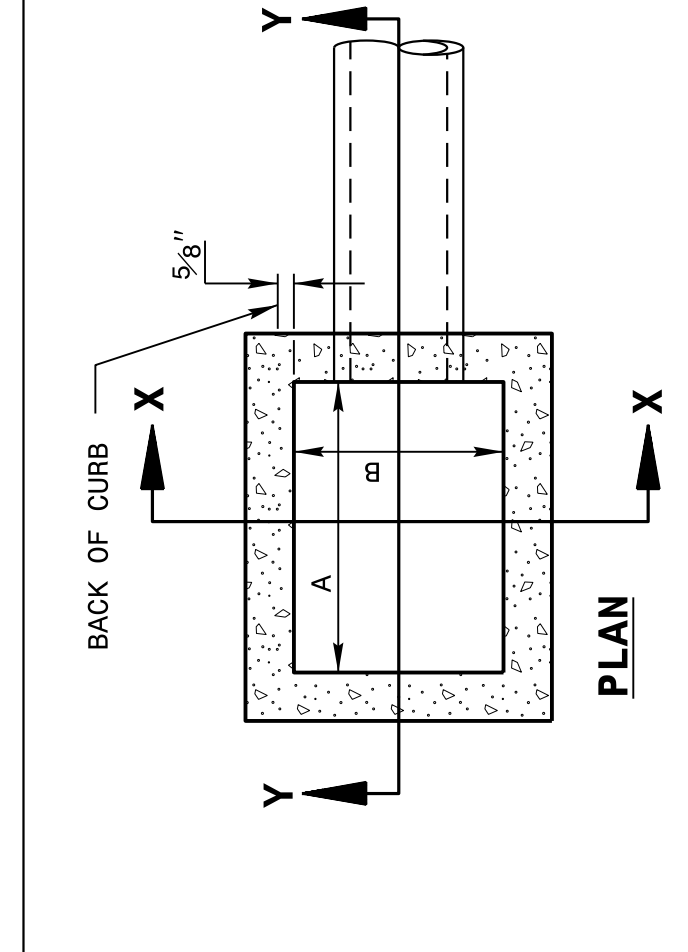

STATE OF NORTH CAROLINA  
 DEPT. OF TRANSPORTATION  
 DIVISION OF HIGHWAYS  
 RALEIGH, N.C.

ENGLISH DETAIL DRAWING FOR  
**EXTRA DEPTH  
 CONCRETE CATCH BASIN**  
 12" THRU 84" PIPE

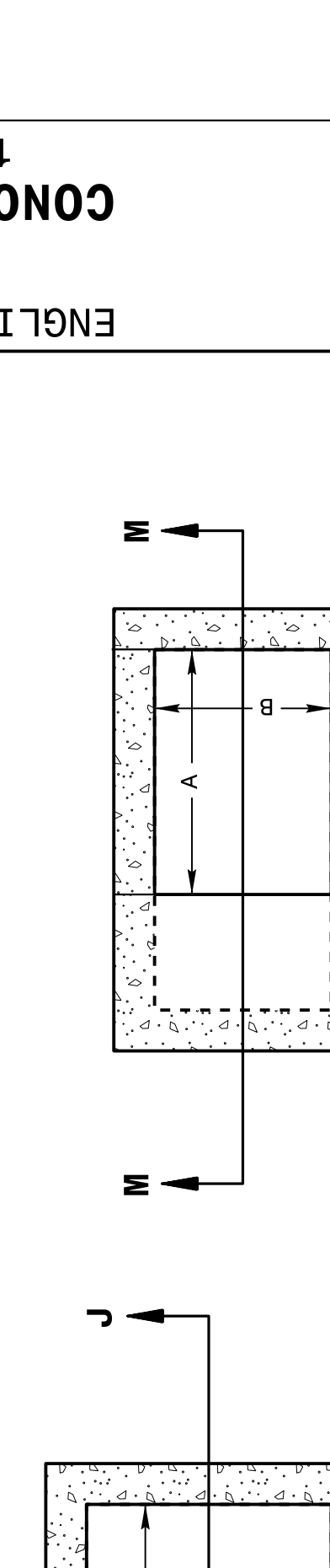
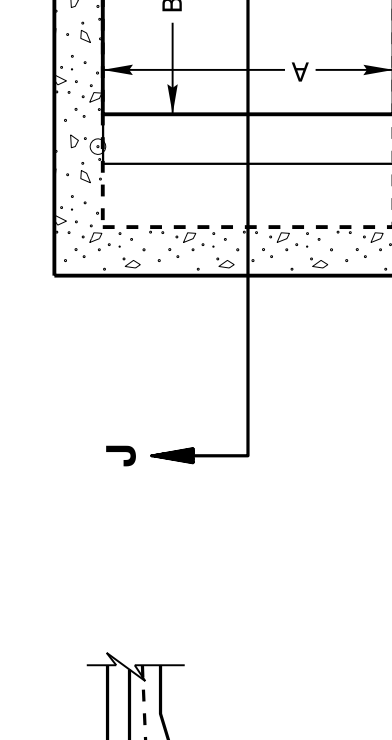
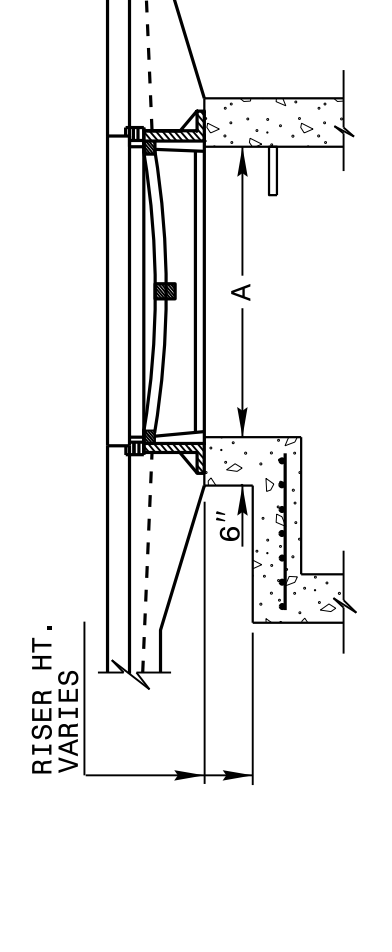
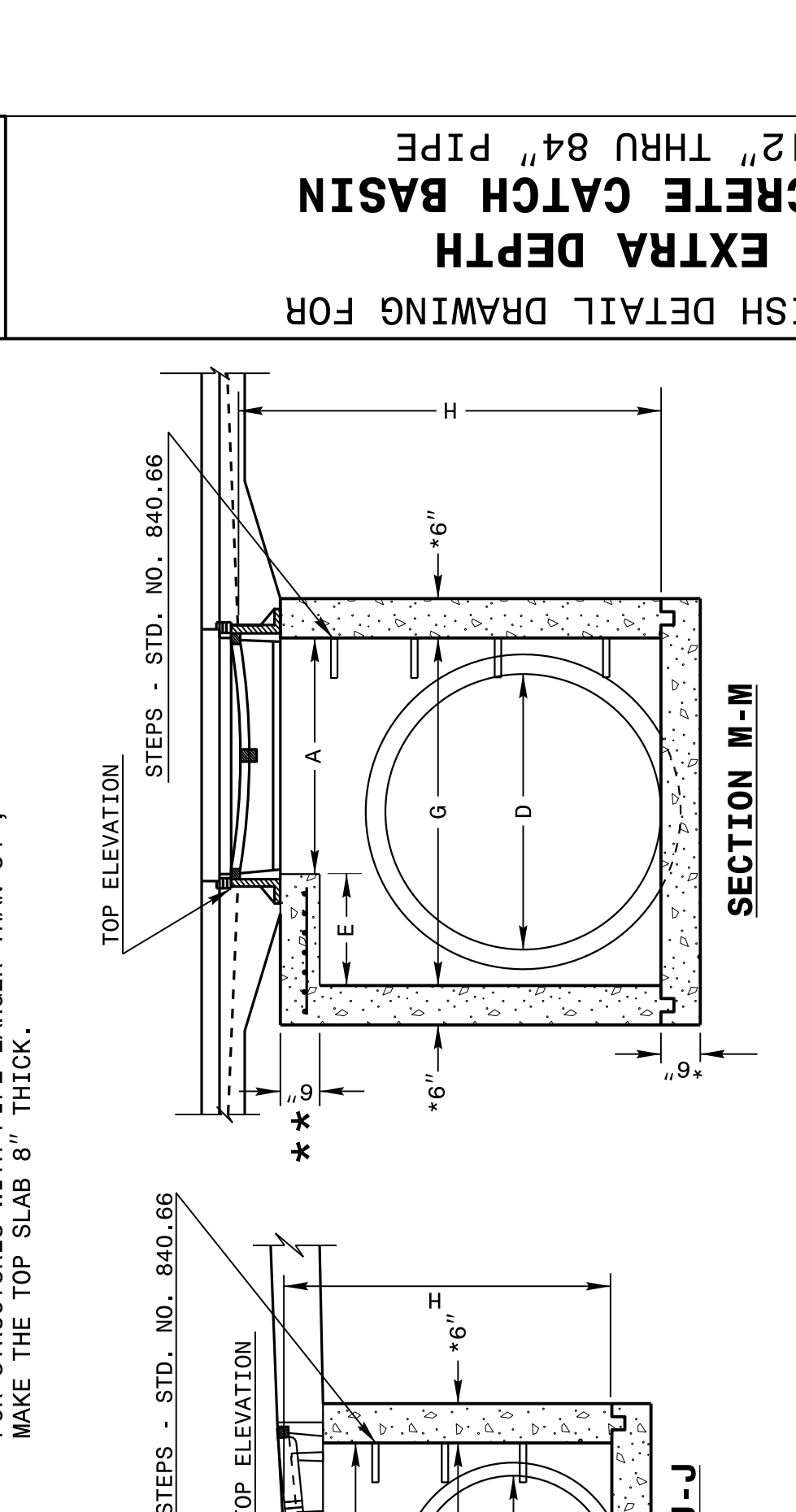
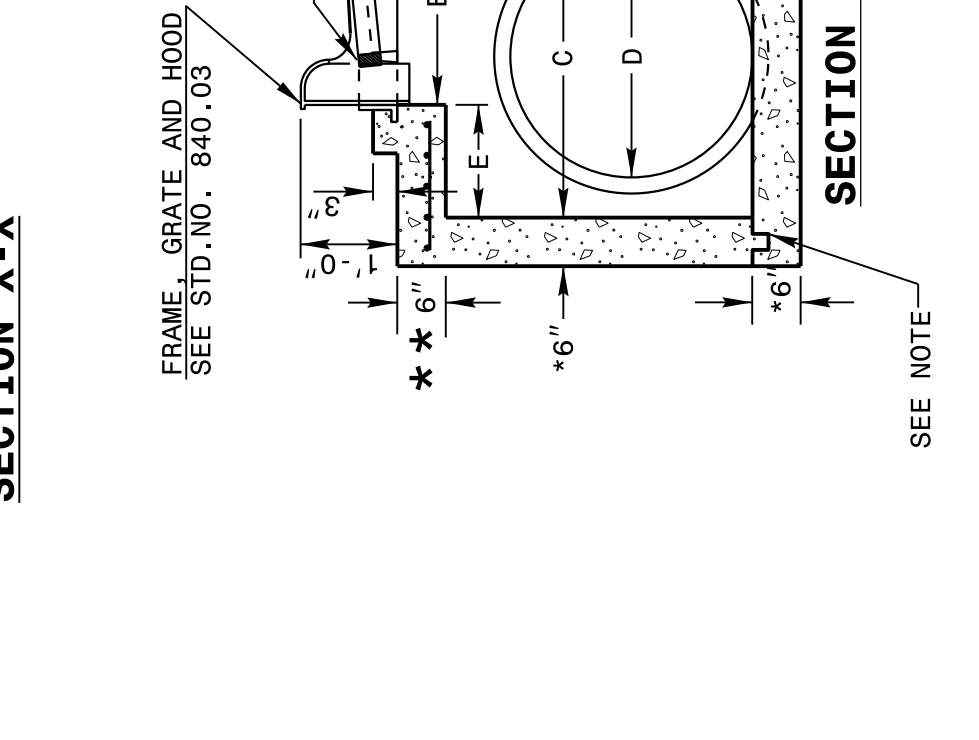
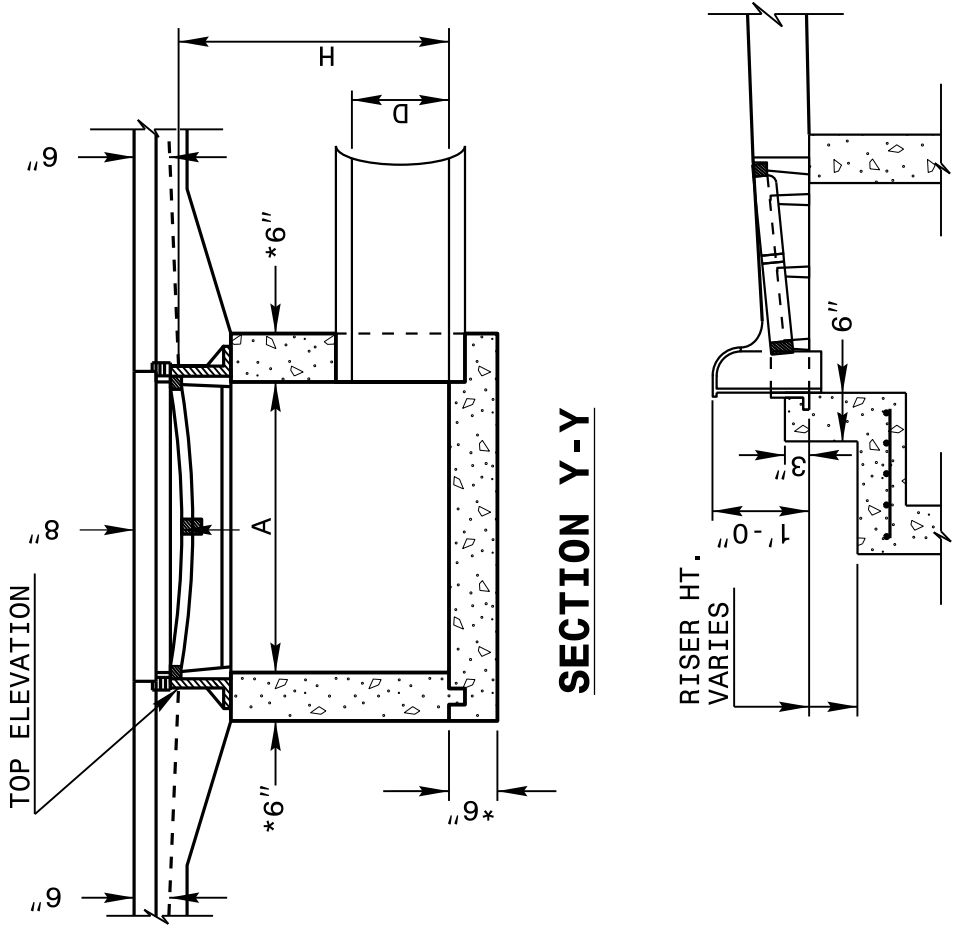

SHEET 1 OF 2  
**840D02**

SHEET 1 OF 2  
**840D02**

STATE OF NORTH CAROLINA  
 DEPT. OF TRANSPORTATION  
 DIVISION OF HIGHWAYS  
 RALEIGH, N.C.

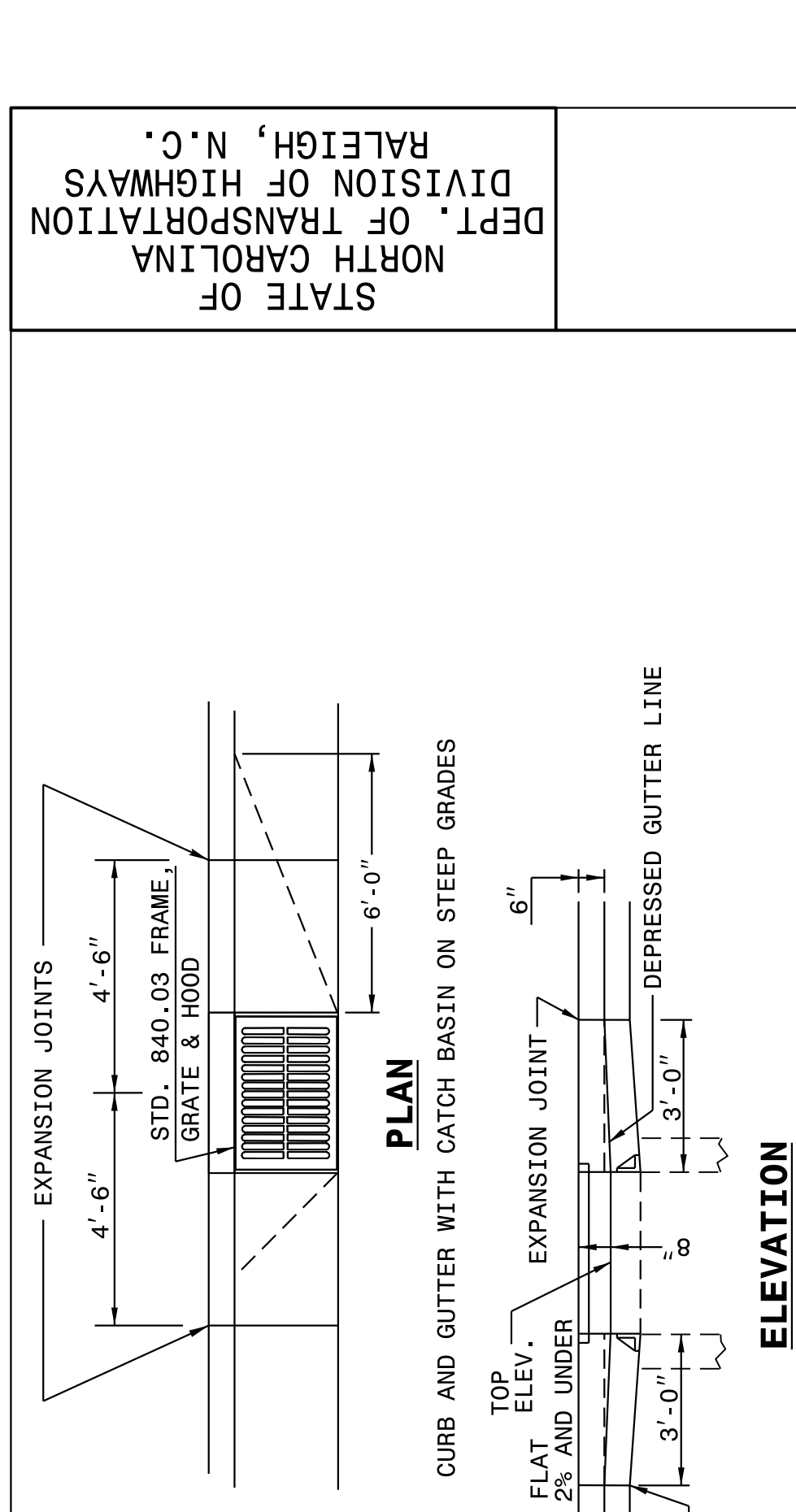
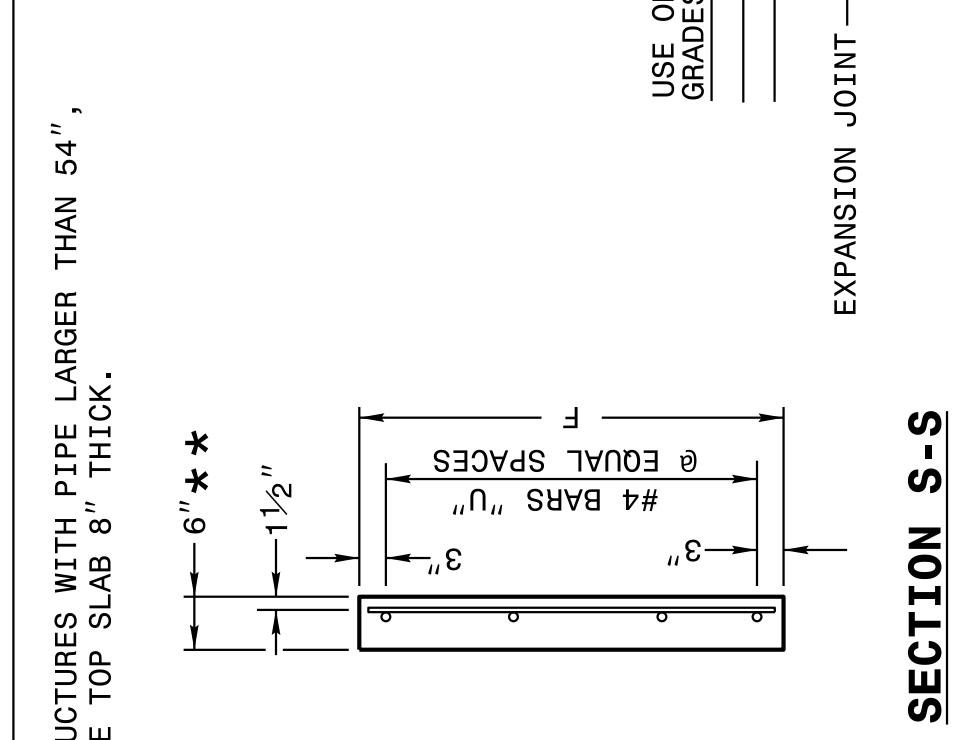
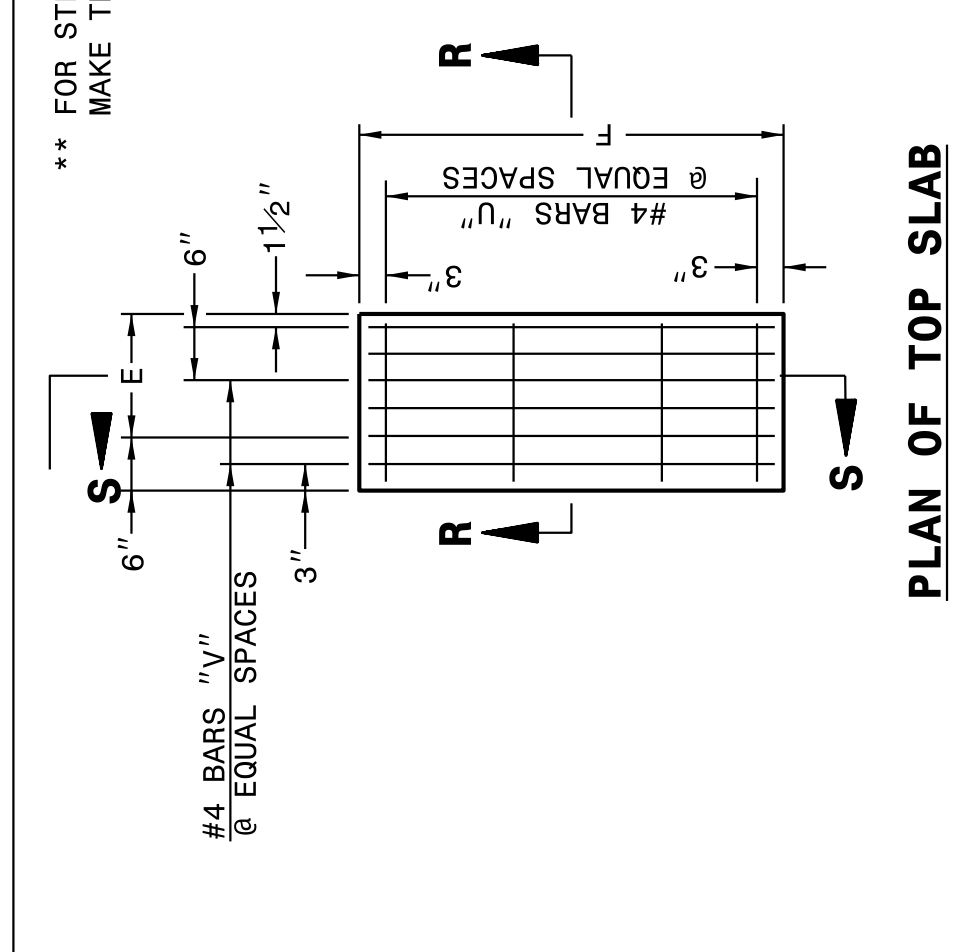

ENGLISH DETAIL DRAWING FOR  
**EXTRA DEPTH  
 CONCRETE CATCH BASIN**  
 12" THRU 84" PIPE

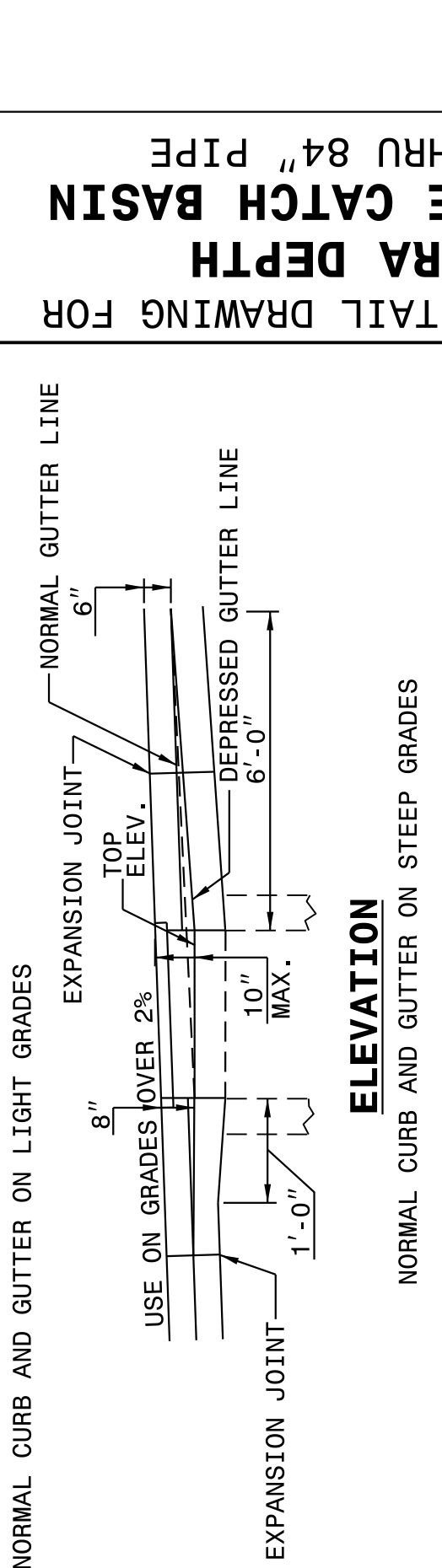
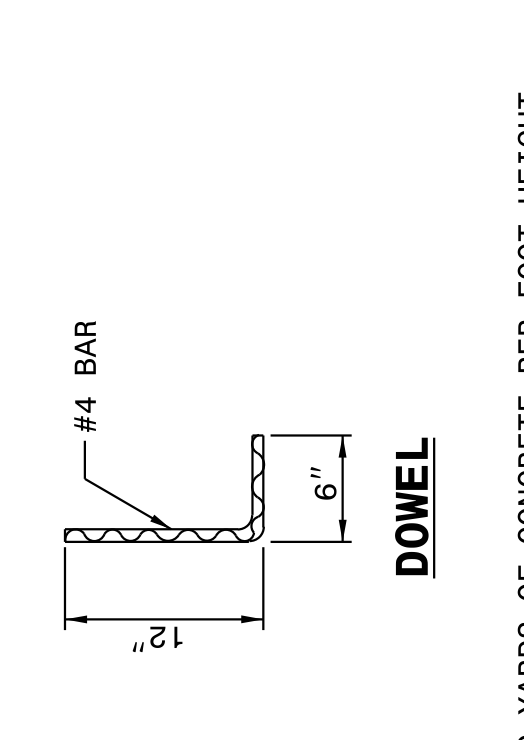
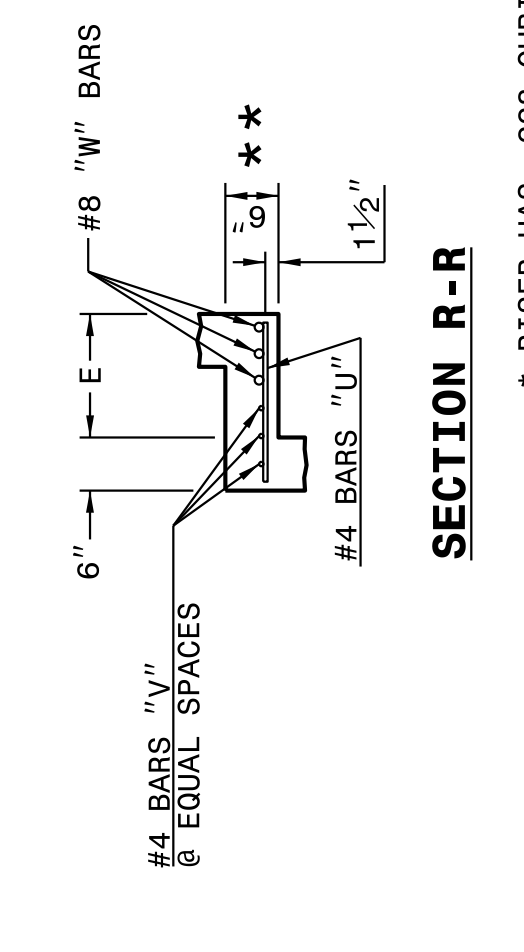

SHEET 2 OF 2  
**840D02**

SHEET 2 OF 2  
**840D02**

\* RISER HAS .228 CUBIC YARDS OF CONCRETE PER FOOT HEIGHT

PIPE D.	MINIMUM DIMENSIONS OF BOX AND PIPE			COVER DIMENSION			BARS-U			BARS-V			BARS-W			TOTAL			DEDUCTIONS			
	SPAN	WIDTH	HEIGHT	E	F	G	NO.	LENGTH	NO.	LENGTH	NO.	LENGTH	NO.	LENGTH	LBS.	CU. YDS.	CONC. IN BOX	TOP SLAB	BOTTOM SLAB	TOT. CONC. FOR MINIMUM HEIGHT, H.	ONE PIPE	R.C.
12"	3'-0"	2'-2"	2'-0"	..	2'-0"	2'-3"	..	..	..	..	..	..	..	..	..	..	0.235	0.772	0.015	0.026	0.015	0.026
15"	3'-0"	2'-2"	2'-3"	..	2'-3"	2'-6"	..	..	..	..	..	..	..	..	..	..	0.235	0.829	0.023	0.036	0.023	0.049
18"	3'-0"	2'-2"	3'-1"	..	3'-1"	3'-4"	..	..	..	..	..	..	..	..	..	..	0.235	0.887	0.033	0.049	0.033	0.049
24"	3'-0"	2'-2"	3'-4"	..	3'-4"	3'-7"	..	..	..	..	..	..	..	..	..	..	0.235	0.945	0.043	0.065	0.043	0.065
30"	3'-0"	2'-2"	3'-7"	..	3'-7"	4'-0"	..	..	..	..	..	..	..	..	..	..	0.235	1.003	0.053	0.087	0.053	0.087
36"	3'-0"	2'-2"	4'-0"	..	4'-0"	4'-3"	..	..	..	..	..	..	..	..	..	..	0.235	1.061	0.063	0.101	0.063	0.101
42"	3'-0"	2'-2"	4'-3"	..	4'-3"	4'-6"	..	..	..	..	..	..	..	..	..	..	0.235	1.119	0.073	0.119	0.073	0.119
48"	3'-0"	2'-2"	4'-6"	..	4'-6"	4'-9"	..	..	..	..	..	..	..	..	..	..	0.235	1.177	0.083	0.137	0.083	0.137
54"	3'-0"	2'-2"	4'-9"	..	4'-9"	5'-0"	..	..	..	..	..	..	..	..	..	..	0.235	1.235	0.093	0.155	0.093	0.155
60"	3'-0"	2'-2"	5'-0"	..	5'-0"	5'-3"	..	..	..	..	..	..	..	..	..	..	0.235	1.293	0.103	0.173	0.103	0.173
66"	3'-0"	2'-2"	5'-3"	..	5'-3"	5'-6"	..	..	..	..	..	..	..	..	..	..	0.235	1.351	0.113	0.191	0.113	0.191
72"	3'-0"	2'-2"	5'-6"	..	5'-6"	5'-9"	..	..	..	..	..	..	..	..	..	..	0.235	1.409	0.123	0.209	0.123	0.209
78"	3'-0"	2'-2"	5'-9"	..	5'-9"	6'-0"	..	..	..	..	..	..	..	..	..	..	0.235	1.467	0.133	0.227	0.133	0.227
84"	3'-0"	2'-2"	6'-0"	..	6'-0"	6'-3"	..	..	..	..	..	..	..	..	..	..	0.235	1.525	0.143	0.245	0.143	0.245

CONTRACT STANDARDS  
 AND DEVELOPMENT UNIT  
 Office 919-707-6950 FAX 919-250-4119

**SEE PLATE FOR TITLE**

ORIGINAL BY: 2002 Std.840.01 DATE: \_\_\_\_\_  
 MODIFIED BY: E.E. WARD DATE: 3-1-02  
 CHECKED BY: \_\_\_\_\_ DATE: \_\_\_\_\_  
 FILE SPEC.: jhewerton/840d02 Extra\_Depth CB.dgn

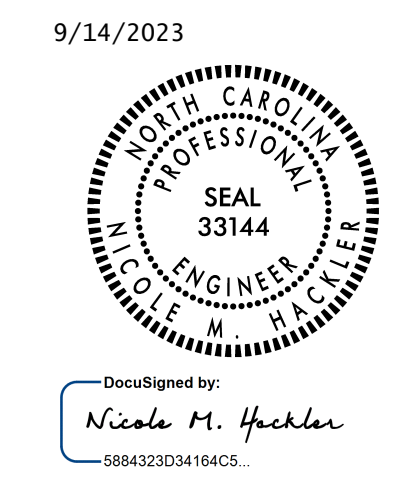

9/14/2023

DOCUMENT NOT CONSIDERED FINAL  
 UNLESS ALL SIGNATURES COMPLETED



STATE OF NORTH CAROLINA  
DEPT. OF TRANSPORTATION  
DIVISION OF HIGHWAYS  
RALEIGH, N.C.

ENGLISH DETAIL DRAWING FOR  
**METHOD FOR PLACEMENT OF  
DROP INLETS IN CONCRETE ISLANDS**

SHEET 1 OF 1  
**852D06**

STATE OF NORTH CAROLINA  
DEPT. OF TRANSPORTATION  
DIVISION OF HIGHWAYS  
RALEIGH, N.C.

ENGLISH DETAIL DRAWING FOR  
**METHOD FOR PLACEMENT OF  
DROP INLETS IN CONCRETE ISLANDS**

SHEET 1 OF 1  
**852D06**

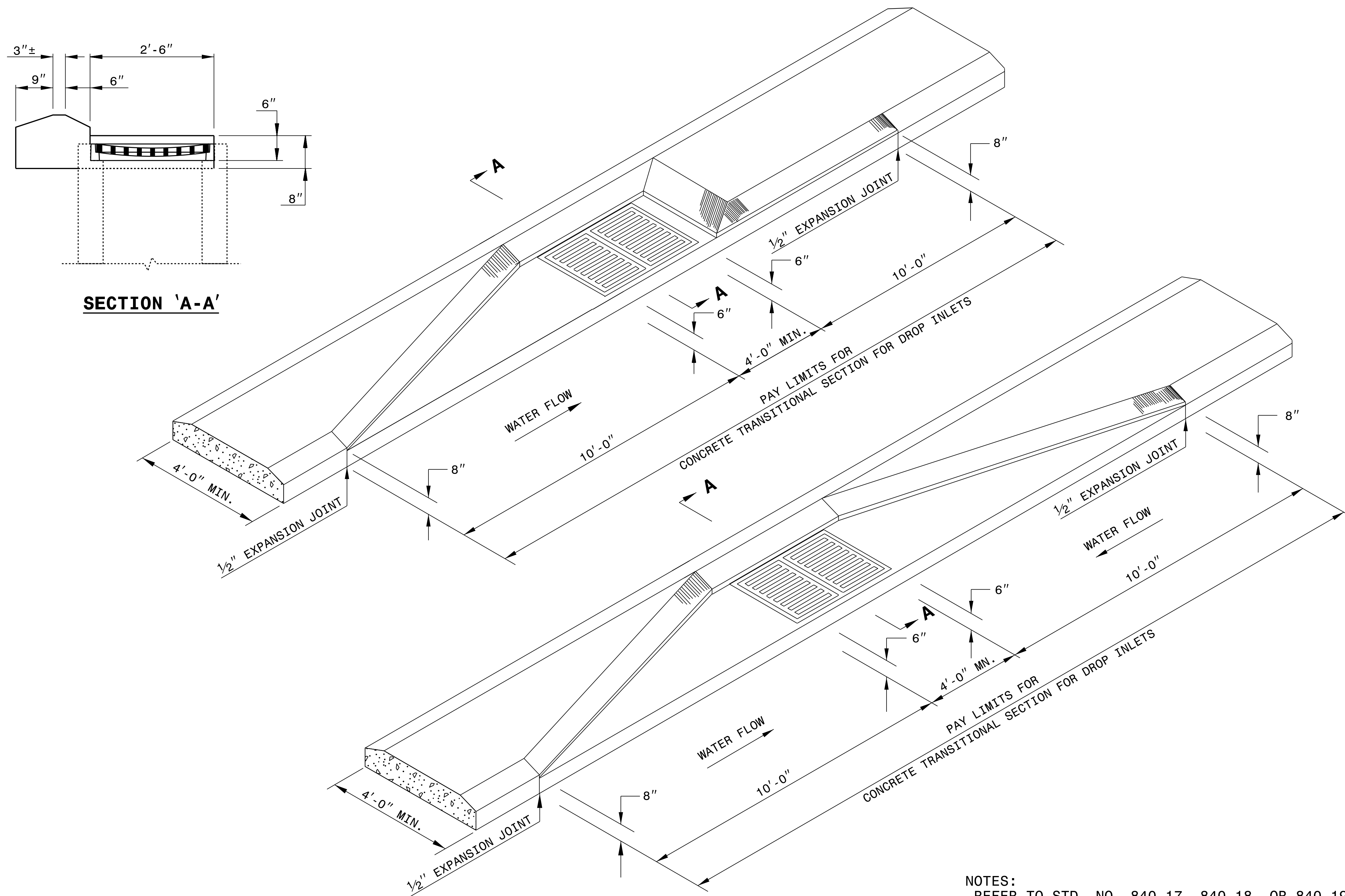

NOTES:  
 -REFER TO STD. NO. 840.17, 840.18, OR 840.19 FOR DRAINAGE STRUCTURE.  
 -REFER TO STD. NO. 840.20 OR 840.29 FOR GRATE AND FRAME.

06-MAR-2018 10:58 S:\Contracts\Projects\Spccal1\_Details\kkempf\english\852D0601.dgn J:\power\ton AT\_CSD-292595

9/26/2023

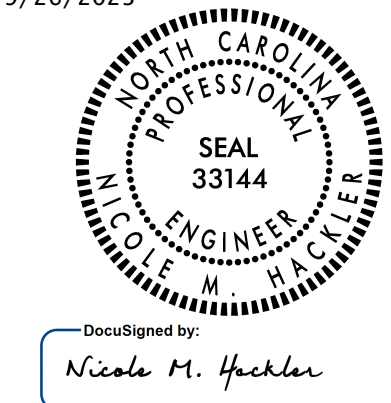

DocuSigned by:  
Nicole M. Heckler  
588432034164C5

DOCUMENT NOT CONSIDERED FINAL  
UNLESS ALL SIGNATURES COMPLETED

CONTRACT STANDARDS  
AND DEVELOPMENT UNIT  
Office 919-707-6950 FAX 919-250-4119

**SEE TITLE PLATE**

ORIGINAL BY: KKEMPF DATE: 8/2/10  
 MODIFIED BY: DATE:  
 CHECKED BY: DATE:  
 FILE SPEC.: KKEMPF\ENGLISH\852D0601.DGN

5/28/99

STATE OF NORTH CAROLINA  
DIVISION OF HIGHWAYS

PROJECT REFERENCE NO. <i>U-5824</i>	SHEET NO. <i>3B-1</i>
Prepared in the Office of: <b>SUMMIT</b> ENGINEERING & CONSTRUCTION SERVICES	
<small>NC FIRM LICENSE No. P-0339 320 Executive Ct. Hillsborough, NC 27278 (919) 732-3883 (919) 732-6676 (FAX)</small>	

"N" = DISTANCE FROM EDGE OF LANE TO FACE OF GUARDRAIL.  
TOTAL SHOULDER WIDTH = DISTANCE FROM EDGE OF TRAVEL LANE TO SHOULDER BREAK POINT.  
FLARE LENGTH = DISTANCE FROM LAST SECTION OF PARALLEL GUARDRAIL TO END OF GUARDRAIL.  
W = TOTAL WIDTH OF FLARE FROM BEGINNING OF TAPER TO END OF GUARDRAIL.  
G = GATING IMPACT ATTENUATOR TYPE 350  
NG = NON-GATING IMPACT ATTENUATOR TYPE 350

**GUARDRAIL SUMMARY**

SURVEY LINE	BEG. STA.	END STA.	LOCATION	LENGTH			WARRANT POINT		"N" DIST. FROM E.O.L.	TOTAL SHOUL. WIDTH	FLARE LENGTH		W		ANCHORS							IMPACT ATTENUATOR TYPE 350			SINGLE FACED GUARDRAIL	REMOVE EXISTING GUARDRAIL	REMOVE AND STOCKPILE EXISTING GUARDRAIL	REMARKS						
				STRAIGHT	SHOP CURVED	DOUBLE FACED	APPROACH END	TRAILING END			APPROACH END	TRAILING END	APPROACH END	TRAILING END	XI MOD	GREU TL-2	GREU TL-3	B-77	XIII	CAT-1	VI MOD	BIC	AT-1	EA					G	NG				
-L-	18+93.00	21+50.00	LT	250			18+93.00		2.5'	10'	50'		1'																					LOCATED AT FACE OF CURB
-L-	29+99.00	31+55.00	RT	156.25			29+99.00		12'	14'	50'		1'																				LOCATED 12' FROM FACE OF CURB	
-L-	44+42.00	47+49.00	LT	312.50			44+42.00		2.5'	10'	50'		1'																				LOCATED AT FACE OF CURB	
-L-	52+93.75	54+72.00	LT	181.25			54+50.00		2.5'	13'	50'		1'																				LOCATED AT FACE OF CURB	
-L-	53+64.00	55+01.75	RT	143.75			53+70.00		2.5'	13'	50'		1'																				LOCATED AT FACE OF CURB	
-L-	56+35.00	59+06.25	RT	275			56+40.00		2.5'	13'	50'		1'																				LOCATED AT FACE OF CURB	
-L-	99+09.00	101+06.00	RT	187.50	75		100+08.65		2.5'	6'	50'		1'																				LOCATED AT FACE OF CURB	
SUBTOTAL				1506.25	75																													
LESS DEDUCTIONS FOR ANCHORS																																		
7 GREU TL-3				-350																														
7 CAT-1				-43.75																														
TOTALS				1112.50	75																													

**SUMMARY OF ASPHALT PAVEMENT REMOVAL**

LOCATION	AREA (SQYD)
-L- STA. 17+28.00 TO 20+30.00	322.28
-L- STA. 19+62.00 TO 25+40.00	226.30
-L- STA. 34+50.00 TO 41+25.00	1914.08
-L- STA. 43+16.00 TO 47+06.00	816.84
-L- STA. 43+16.00 TO 49+99.00	630.90
-L- STA. 49+99.00 TO 52+00.00	654.61
-L- STA. 50+52.00 TO 54+19.00	375.88
-L- STA. 60+66.00 TO 62+85.00	103.00
-L- STA. 68+71.00 TO 75+21.00	835.76
-L- STA. 77+82.00 TO 85+17.00	933.13
-L- STA. 90+40.00 TO 93+44.00	416.03
-L- STA. 17+18.50 TO 21+38.32	261.94
-L- STA. 47+76.15 TO 50+77.61	398.13
-L- STA. 57+04.00 TO 62+85.90	608.14
-L- STA. 66+17.92 TO 68+27.40	97.44
-Y11A- STA. 10+28.00 TO 10+97.00	104.90
TOTAL	8699.36
SAY	8700

14-SEP-2003 11:53  
U-5824\_R06\_s1m-3B1.dgn  
faulstich











ROADLAP12018C

COMPUTED BY: HY DATE: 2/20/2023
CHECKED BY: PMH DATE: 7/12/2023

NORTH CAROLINA DEPARTMENT OF TRANSPORTATION
DIVISION OF HIGHWAYS

PROJECT NO. SHEET NO.
U-5824 3D-3

Note: Invert Elevations indicated are for Bid Purposes only and shall not be used for project construction stakeout.
See "Standard Specifications For Roads and Structures, Section 300-5".

LIST OF PIPES, ENDWALLS, ETC. (FOR PIPES 48 INCHES & UNDER)

Table with columns for Line & Station, Offset, Structure Number, Invert Elevation, Minimum Required Slope, Drainage Pipe, R.C. Pipe Class III/IV, Endwalls, Reinforced Endwalls, Drainage Structure, Quantities for Drainage Structures, Frame, Grates, and Hood, Concrete Transitional Section, and Remarks. Includes a SHEET TOTALS row at the bottom.

ABBREVIATIONS
C.A.A. CORRUGATED ALUMINIUM ALLOY
C.B. CATCH BASIN
C.S. CORRUGATED STEEL
D.I. DROP INLET
G.D.I. GRATED DROP INLET
H.D.P.E. HIGH DENSITY POLYETHYLENE
J.B. JUNCTION BOX
M.H. MANHOLE
N.S. NARROW SLOT
P.V.C. POLYVINYL CHLORIDE
R.C. REINFORCED CONCRETE
T.B.D.I. TRAFFIC BEARING DROP INLET
T.B.J.B. TRAFFIC BEARING JUNCTION BOX
W.S. WIDE SLOT



ROADLAP12016C

COMPUTED BY: HY DATE: 2/20/2023  
CHECKED BY: PMH DATE: 7/12/2023

PROJECT NO. SHEET NO.  
U-5824 3D-4

NORTH CAROLINA DEPARTMENT OF TRANSPORTATION  
DIVISION OF HIGHWAYS

Note: Invert Elevations indicated are for Bid Purposes only and shall not be used for project construction stakeout.  
See "Standard Specifications For Roads and Structures, Section 300-5".

LIST OF PIPES, ENDWALLS, ETC. (FOR PIPES 48 INCHES & UNDER)

Table with columns for Line & Station, Offset, Structure Number, Invert Elevation, Minimum Required Slope, Drainage Pipe, R.C. Pipe Class III, R.C. Pipe Class IV, Endwalls, Reinforced Endwalls, Drainage Structure, Quantities for Drainage Structures, Frame, Grates, and Hood, Concrete Transitional Section, Grate Type, and Remarks. Includes a SHEET TOTALS row at the bottom.





COMPUTED BY: HY DATE: 2/20/2023  
CHECKED BY: PMH DATE: 7/12/2023

PROJECT NO. SHEET NO.  
U-5824 3D-6

NORTH CAROLINA DEPARTMENT OF TRANSPORTATION  
DIVISION OF HIGHWAYS

Note: Invert Elevations indicated are for Bid Purposes only and shall not be used for project construction stakeout.  
See "Standard Specifications For Roads and Structures, Section 300-5".

LIST OF PIPES, ENDWALLS, ETC. (FOR PIPES 48 INCHES & UNDER)

Main data table with columns: LINE & STATION, OFFSET, STRUCTURE NUMBER, TOP ELEVATION, INVERT ELEVATION, MINIMUM REQUIRED SLOPE, Drainage Pipe (RCP, CSP, CAAP, HDPE, PVC, or PP PIPE), R. C. PIPE CLASS III, R. C. PIPE CLASS IV, ENDWALLS, REINFORCED ENDWALLS, MASONRY, DRAINAGE STRUCTURE, QUANTITIES FOR DRAINAGE STRUCTURES (A, B), FRAME, GRATES, AND HOOD, CONCRETE TRANSITIONAL SECTION, GRAPE TYPE, and REMARKS.

ABBREVIATIONS table listing symbols and their corresponding material names like C.A.A. CORRUGATED ALUMINIUM ALLOY, C.B. CATCH BASIN, etc.

SHEET TOTALS

Summary row for SHEET TOTALS showing counts for various pipe sizes and materials across the sheet.





ROADLAP12018C

COMPUTED BY: HY DATE: 2/20/2023  
CHECKED BY: PMH DATE: 7/12/2023

PROJECT NO. SHEET NO.  
U-5824 3D-8

NORTH CAROLINA DEPARTMENT OF TRANSPORTATION  
DIVISION OF HIGHWAYS

Note: Invert Elevations indicated are for Bid Purposes only and shall not be used for project construction stakeout.  
See "Standard Specifications For Roads and Structures, Section 300-5".

LIST OF PIPES, ENDWALLS, ETC. (FOR PIPES 48 INCHES & UNDER)

Table with columns: LINE & STATION, OFFSET, STRUCTURE NUMBER, TOP ELEVATION, INVERT ELEVATION, MINIMUM REQUIRED SLOPE, Drainage Pipe (RCP, CSP, CAAP, HDPE, PVC, or PP PIPE), R. C. PIPE CLASS III, R. C. PIPE CLASS IV, ENDWALLS, REINFORCED ENDWALLS, MASONRY, DRAINAGE STRUCTURE, QUANTITIES FOR DRAINAGE STRUCTURES, FRAME, GRATES, AND HOOD, CONCRETE TRANSITIONAL SECTION, and REMARKS. Includes a SHEET TOTALS row at the bottom.





ROADLAP12018C

COMPUTED BY: HY DATE: 2/20/2023
CHECKED BY: PMH DATE: 7/12/2023

NORTH CAROLINA DEPARTMENT OF TRANSPORTATION
DIVISION OF HIGHWAYS

PROJECT NO. SHEET NO.
U-5824 3D-10

Note: Invert Elevations indicated are for Bid Purposes only and shall not be used for project construction stakeout. See "Standard Specifications For Roads and Structures, Section 300-5".

LIST OF PIPES, ENDWALLS, ETC. (FOR PIPES 48 INCHES & UNDER)

Table with columns for Line & Station, Offset, Structure Number, Invert Elevation, Pipe Size, R.C. Pipe Class, Quantities for Drainage Structures, Frame, Grates, and Hood, and Remarks. Includes sub-totals for SHEET TOTALS and PROJECT TOTALS.

COMPUTED BY: HY DATE: 2/20/2023  
CHECKED BY: PMH DATE: 7/12/2023

PROJECT NO. U-5824 SHEET NO. 3D-11

NORTH CAROLINA DEPARTMENT OF TRANSPORTATION  
DIVISION OF HIGHWAYS

Note: Invert Elevations indicated are for Bid Purposes only and shall not be used for project construction stakeout.  
See "Standard Specifications For Roads and Structures, Section 300-5".

LIST OF PIPES, ENDWALLS, ETC. (FOR PIPES 54 INCHES & OVER)

Main data table with columns for Line & Station, Offset, Structure Number, Invert Elevation, Minimum Required Slope, R.C. Pipe Class III (12-84 inch diameters), Endwalls, Reinforced Endwalls, Drainage Structure, Quantities for Drainage Structures (A/B), Frame, Grates, and Hood (STD. 840.03), Grate Type (E/F/G), Concrete Transitional Section (D.I./C.B.), Open Throat C.B., D.I. STD., D.I. Frame and Grates, G.D.I. Type, G.D.I. (W.S. Flat) Frame, G.D.I. (W.S. Sag) Frame, G.D.I. (N.S. Sag) Frame, G.D.I. (N.S. Flat) Frame, Drive Way D.I., Frame W/ Grate For Driveway, J.B. STD., T.B.J.B. STD., T.B.D.I. STD., Steel Frame with Two Grates, Temp Steel Plate Cover Masonry Drainage, M.H. STD., M.H. Frame and Cover, Convert Existing C.B., Adjust D.I., 15" C.S. Elbow, 18" C.S. Elbow, 24" C.S. Elbow, 30" C.S. Elbow, 36" C.S. Elbow, Berm Ditch Outlet, Modified Conc. Flume, Preformed Scour Hole, Energy Dissipation Basin, Flowable Fill, Concrete Collars, Concrete and Brick Pipe Plug, and Pipe Removal.

ABBREVIATIONS table listing materials like CORRUGATED ALUMINIUM ALLOY, CATCH BASIN, CORRUGATED STEEL, DROP INLET, GRATED DROP INLET, HIGH DENSITY POLYETHYLENE, JUNCTION BOX, MANHOLE, NARROW SLOT, POLYVINYL CHLORIDE, REINFORCED CONCRETE, TRAFFIC BEARING DROP INLET, TRAFFIC BEARING JUNCTION BOX, WIDE SLOT.

REMARKS

SHEET TOTALS  
PROJECT TOTALS

Summary table with columns for various material quantities and totals, including values for 152, 5.600, 9.207, 1, and 1.



COMPUTED BY: HDP DATE: 09/22/2023  
 CHECKED BY: BS DATE: 09/22/2023

(2-3-23)

PROJECT NO. U-5824 SHEET NO. 3G-1

**STATE OF NORTH CAROLINA  
 DIVISION OF HIGHWAYS**

**SUMMARY OF SUBSURFACE DRAINAGE**

LINE	Station	Station	Location LT/RT/CL	Drain Type* UD/BD/SD	LF
CONTINGENCY				SD	500
				<b>TOTAL LF:</b>	500

\*UD = Underdrain  
 \*BD = Blind Drain  
 \*SD = Subsurface Drain

**SUMMARY OF AGGREGATE SUBGRADE/STABILIZATION**

LINE	Station	Station	Aggregate Type* ASU(1/2)/ AST	Aggregate Thickness INCHES [8" for ASU(2)]	Shallow Undercut CY	Class IV Subgrade Stabilization TONS	Geotextile for Subgrade Stabilization SY	Stabilizer Aggregate TONS	Class IV Aggregate Stabilization TONS
-L-	92+75	97+25			500	1800	2800		
-L-	102+75	105+25							
CONTINGENCY					400	800	1200		
					<b>TOTAL CY/TONS/SY:</b>	900	2600**	4000	0

\*ASU(1/2) = Aggregate Subgrade (Type 1 or 2)  
 \*AST = Aggregate Stabilization  
 \*\*Total tons of "Class IV Subgrade Stabilization" and total square yards of "Geotextile for Subgrade Stabilization" are only the estimated quantities for ASU(1/2)/AST and may only represent a portion of the subgrade stabilization and geotextile quantities shown in the Item Sheets of the Proposal.

**STATE OF NORTH CAROLINA  
DIVISION OF HIGHWAYS**

**PARCEL INDEX SHEET**

PARCEL No.	SHEET No.	PROPERTY OWNER NAME
2	4	JOHN T VLAHOS
3	4	PELAGIC PARTNERS, LLC.
4	4	A D D VENTURES, LLC. (2 PARCELS)
5	4	DUKE POWER CO (4 PARCELS)
5A	4	DUKE POWER CO
6	4	WALKERTOWN LUBE-N-WASH, INC.
7	4	PRITCHARD, RALPH L.
8	4	DAVID H BATTEN
9	4	WALKERTOWN PENT HOLINESS CHURCH
10	4	TNP HOLDINGS LLC
10A	4,5	TNP HOLDINGS LLC
10B	5	TNP HOLDINGS LLC
11	4	WILLIAM E RUSSELL
12	4,5	JOHN CHONG PEEL
13	5	ELOISE J HALL (2 PARCELS)
14	5	SANDRA ANN WAGGONER (2 PARCELS)
15	5	OLD HOLLOW ROAD PROPERTIES LLC
16	5	WILLIAM H MITCHELL
16A	5	WILLIAM H MITCHELL
17	5	JESSE J NEAL
18	5	RICHARD HESTER PEGRAM
18A	5	JACOB T LANE
19	5	LOUISE J DAVIS
20	5	FAMILY TIES PROPERTIES LLC
21	5	TIGHT KNIT PROPERTIES, LLC
22	5	SHARON TERRELL ELLIOT
23	5,6	DAVID R HEATH
23A	5	DAVID R HEATH
23B	5,6	DAVID R HEATH
23C	6	DAVID R HEATH
24	5	FOX HOLDING COMPANY
25	5,6	CLYDE P WEBSTER
26	6	WALKERTOWN SHOPPING CENTER INC (3 PARCELS)
26A	6	ACADEMY INC
26B	6	STEV I ANDREWS LLC
27	6	JOANN S CARMICHAEL REVOCABLE TRUST
28	6	NANCY S GARRETT (2 PARCELS)
29	6	BETTY CARDELL JENKINS
30	6,7	JOHN B GARRETT JR.
31	6,7	ALL IN INVESTMENTS PROPERTIES
32	7	WALTRUST PROPERTIES INC
33	7	CENTRE STAGE OF WALKERTOWN LLC (2 PARCELS)
34	7	ACV SKYLINE RADO8 LLC
35	7	KEVIN K VESCOVO & CAROL ANN VESCOVO REVOCABLE LIVING TRUST
36	7	CHARLES M SHEETS
37	7	O'REILLY AUTOMOTIVE, INC.
38	7	ROBERT E WILLIAMS
39	7	JIMMY E GARLAND
40	7,8	GEOMEL LLC (2 PARCELS)
41	7,8	SOUTHERN SISTERS
42	8	SETH D RENIGAR
43	8	WALKERTOWN INVESTMENT PROPERTIES LLC
43A	8	WALKERTOWN INVESTMENT PROPERTIES LLC
44	8	PSI WALKERTOWN LLC
45	8	TIGHT KNIT PROPERTIES, LLC
45A	8	TIGHT KNIT PROPERTIES, LLC
46	8	NANCY S THORNE
47	8	JESSE A JONES
48	8	DOROTHY NEAL WARNER

PARCEL No.	SHEET No.	PROPERTY OWNER NAME
49	8	MARY ANN C LINEBERRY
50	8	JT MABE
51	8	SHIRLEY W NOAH
52	8	PHYLLIS C WILLIAMS (2 PARCELS)
53	8,9	EDNA S CUDE HEIRS
53A	9	EDNA S CUDE HEIRS (2 PARCELS)
54	8,9	ISIDRO ESPINOSA
55	8,9	SARAH W HUTCHINGS
56	9	WHITEHALL VILLAGE MASTERS HOMEOWNERS ASSOC. INC
57	9	JOYCE GARTH
58	9	MARY W WILSON ET AL
59	9	PATSY RUTH HUGHES
60	9	ZACHARY W MARTIN
61	9	JAMES DONALD WHITAKER
62	9	KAREN BARROW DILLON
63	9	JAMES DONALD WHITAKER
64	9,10	LIM KOK KHENG
65	9	CAROL F WHICKER
66	9,10	RICHARD MICHAEL PEGRAM
67	10	JOSEPH WAYNE JOYNER
68	10	STEFAN C MILLER
69	10	RICKY L WEATHERMAN
70	10	RICKY MCCOLLEM
71	10	TYLER GAGE CANNON
71A	10	TYLER GAGE CANNON
72	10	JUDY PROPST
73	10	ELIZABETH ANN MALCOLM
74	10	LESTER HOWARD
75	10	DAVID R HEATH
76	10	MORRIS CHAPEL UNITED METHODIST CHURCH
77	10	JEFFREY A MIDKIFF
78	10	JAMES G HOLT
82	10	PAUL L & SHIRLEY W ROBERTS
83	10,11	FRANCES HAMMACK ADER READ (2 PARCELS)
84	11	REP PROPERTY LLC
85	11	TAU NC LP
87	11	GOODWILL INDUSTRIES OF NORTHWEST NC, INC.(2 PARCELS)
88	11	WEIDL PROPERTIES
89	11	BV 188, LLC
90	11	TAU NC1 LP
91	11	13990 HWY 19, LLC.
92	11	WALTER HARVEY NEAL
93	10	EDWARD W & TERESA R ZELL



PROJECT REFERENCE NO. <b>U-5824</b>	SHEET NO. <b>4</b>
RW SHEET NO.	
ROADWAY DESIGN ENGINEER 9/15/2023 FAITH E. JAHNKE NORTH CAROLINA PROFESSIONAL SEAL 046981	HYDRAULICS ENGINEER 9/15/2023 HE YANG NORTH CAROLINA PROFESSIONAL SEAL 054713
<b>DOCUMENT NOT CONSIDERED FINAL UNLESS ALL SIGNATURES COMPLETED</b>	
Prepared in the Office of: <b>SUMMIT</b> NC FIRM LICENSE NO: P-0339 300 EXECUTIVE CT. HILLSBOROUGH, NC 27278 (919) 732-3883 (919) 732-6676 (FAX)	

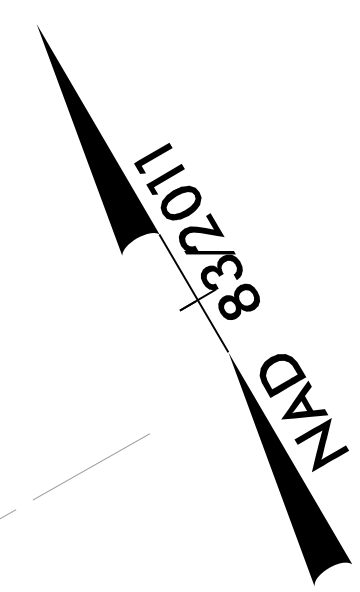

$L$   
 $PI\ Sta\ 16+75.18$   
 $\Delta = 49^\circ 58' 56.1'' (LT)$   
 $D = 6' 01.521''$   
 $L = 828.74'$   
 $T = 442.81'$   
 $R = 950.00'$   
 $SE = 4\%$   
 $RO = 192'$

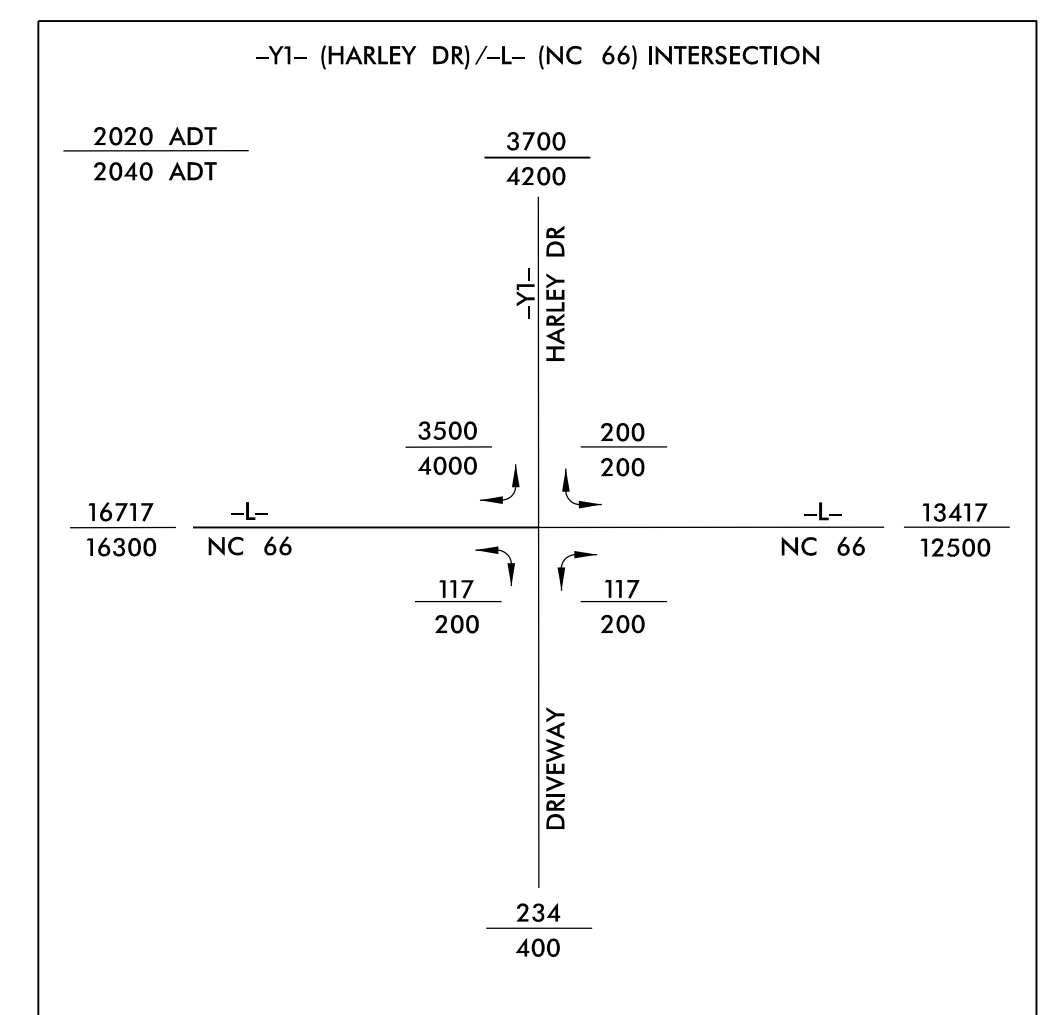

CONTRACTOR WILL NOT BE PERMITTED TO STORE ANY EQUIPMENT ON NS PROPERTY WITHOUT PERMISSION FROM THE NS RAILROAD ENGINEER IN ACCORDANCE WITH SECTION E.6.K.1 OF THE NS PUBLIC PROJECTS MANUAL.

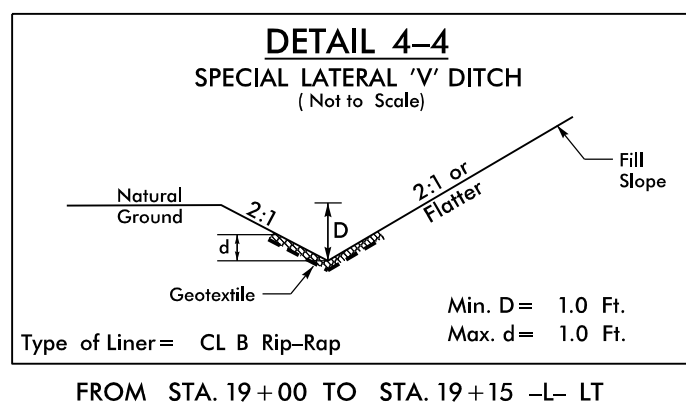
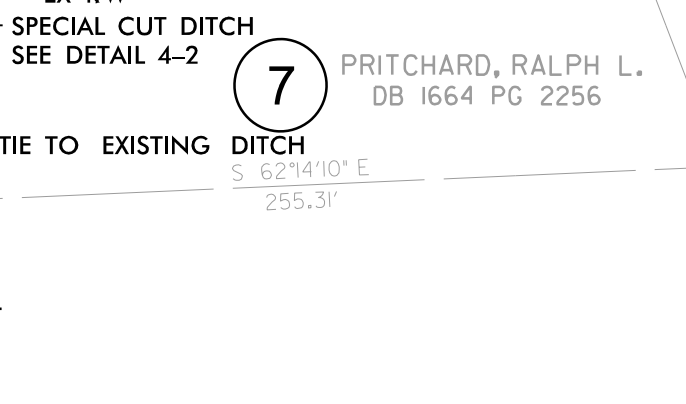
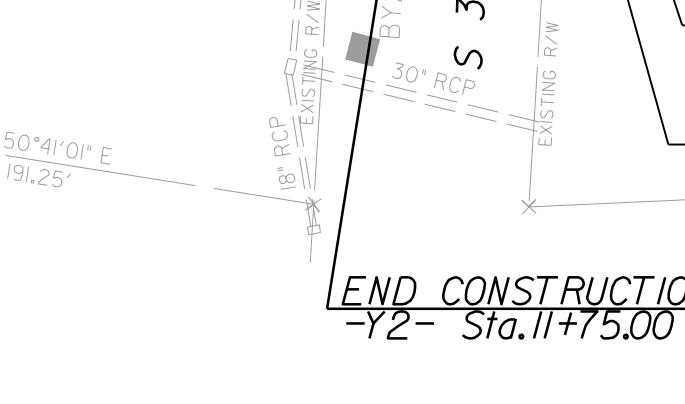
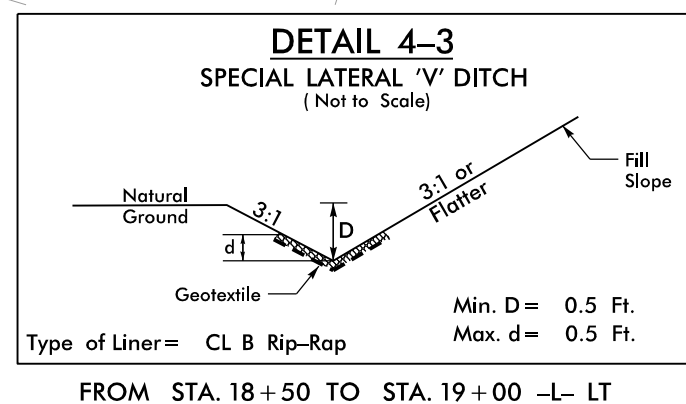
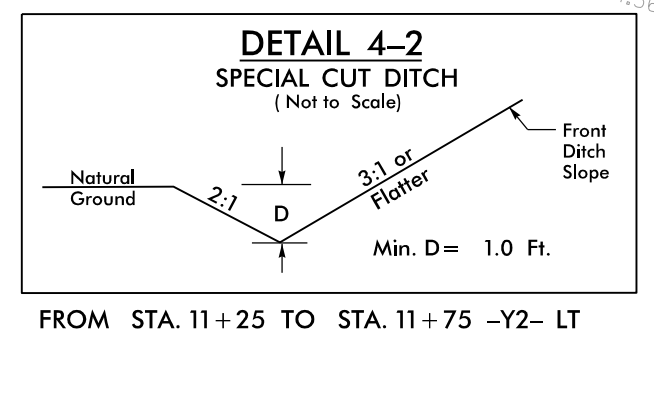
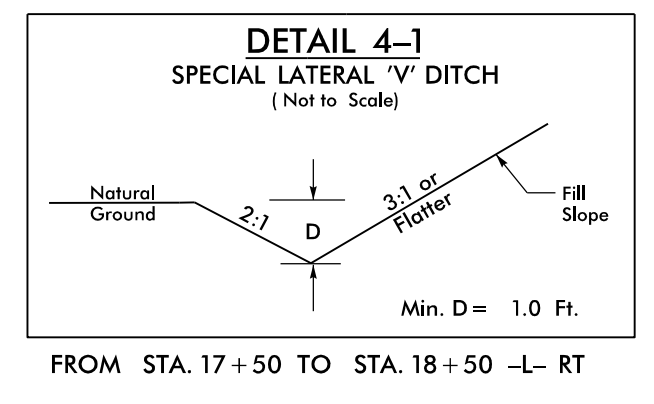
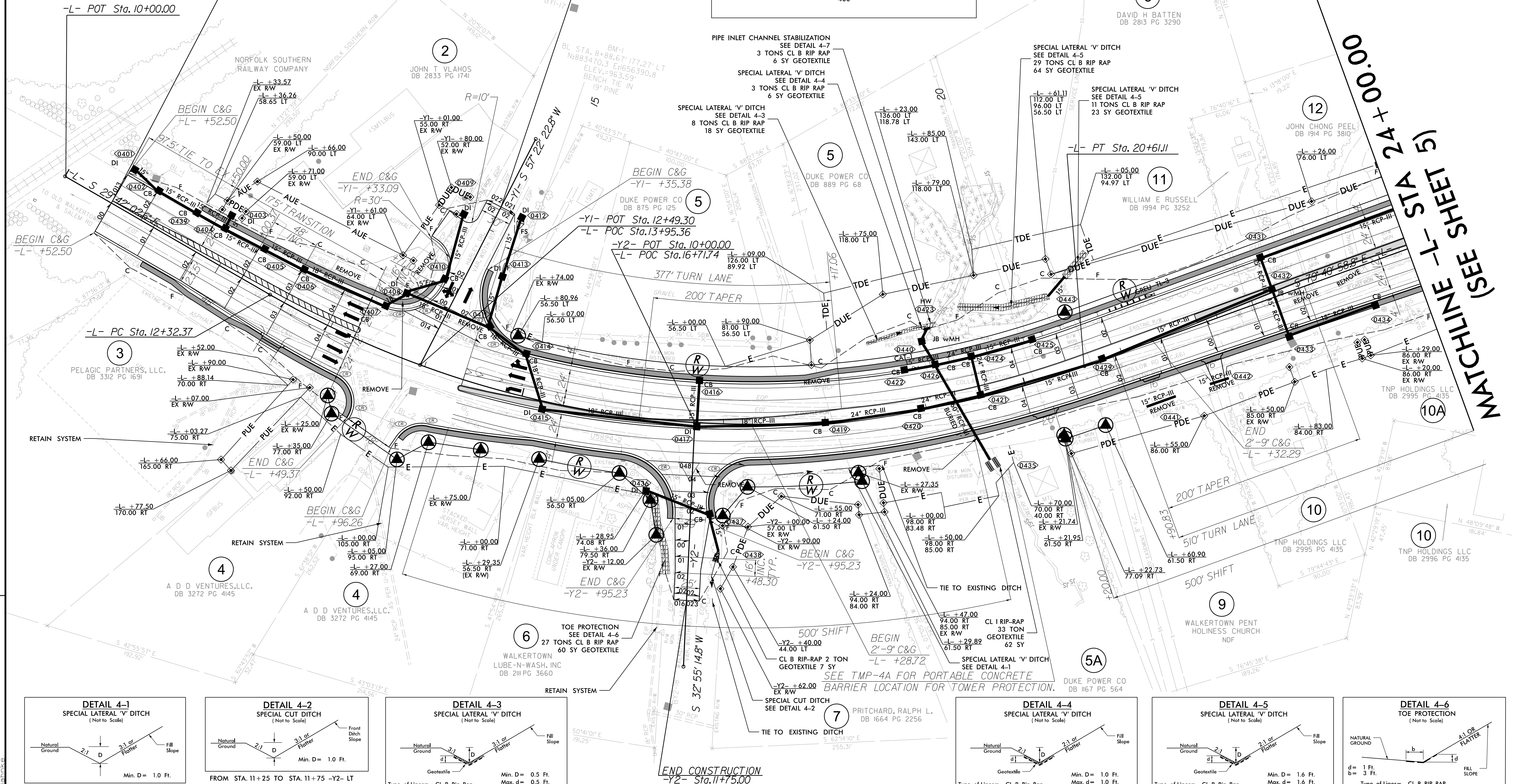

REVISIONS

15-SEP-2023 13:28  
U-5824\_Roadway.dgn  
faith.jahnke

MATCHLINE -L- STA 24+00.00 (SEE SHEET 5)



PROJECT REFERENCE NO. <b>U-5824</b>		SHEET NO. <b>5</b>	
RW SHEET NO.			
ROADWAY DESIGN ENGINEER 9/15/2023 NORTH CAROLINA PROFESSIONAL SEAL 046981 PAUL E. JANKINS		HYDRAULICS ENGINEER 9/15/2023 NORTH CAROLINA PROFESSIONAL SEAL 054713 HE YANG	
<b>DOCUMENT NOT CONSIDERED FINAL UNLESS ALL SIGNATURES COMPLETED</b>			
Prepared in the Office at:		 <small>NC FIRM LICENSE No: P-0339 300 Executive Ct. Hillsborough, NC 27278 (919) 732-3883 (919) 732-6676 (FAX)</small>	

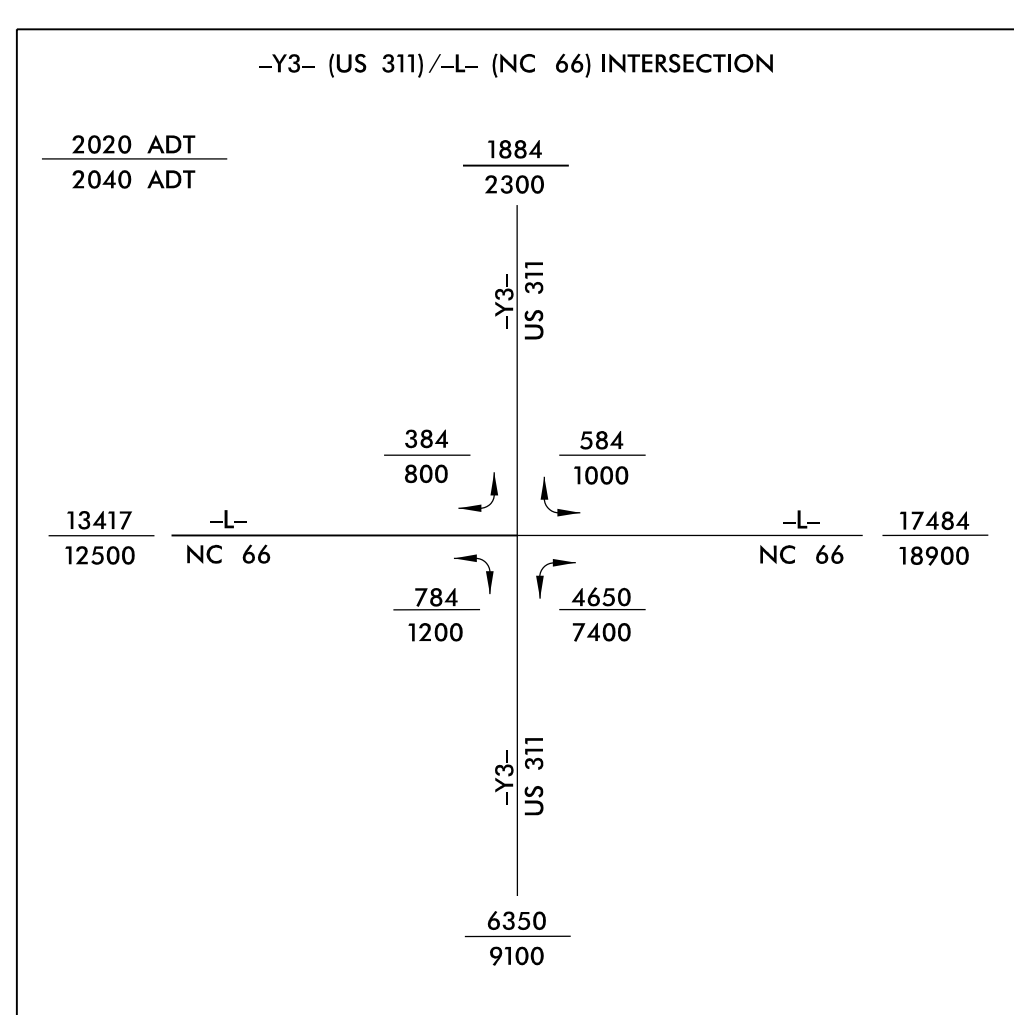

**-L-**

PI Sta 27+14.09	PI Sta 35+33.50
$\Delta = 0^\circ 41' 30.0''$ (RT)	$\Delta = 0^\circ 27' 25.2''$ (LT)
D = 0' 17' 09.8"	D = 0' 17' 12.9"
L = 241.80'	L = 159.29'
T = 120.90'	T = 79.64'
R = 20,030.00'	R = 19,970.00'
SE = NC	SE = NC

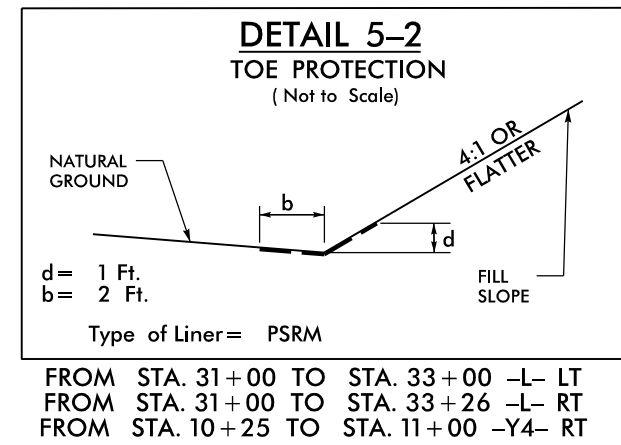
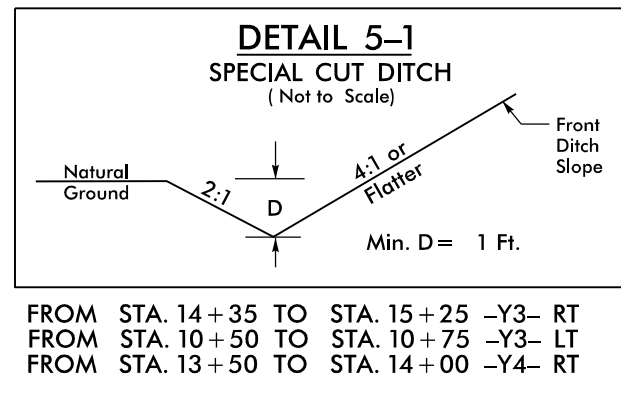

**-Y4-**

PI Sta 10+79.96
$\Delta = 1^\circ 11' 56.8''$ (RT)
D = 1' 08' 45.3"
L = 104.64'
T = 52.32'
R = 5,000.00'

NAD 83/2011

MATCHLINE -L- STA 24+00.00  
(SEE SHEET 4)

MATCHLINE -L- STA 37+00.00  
(SEE SHEET 6)

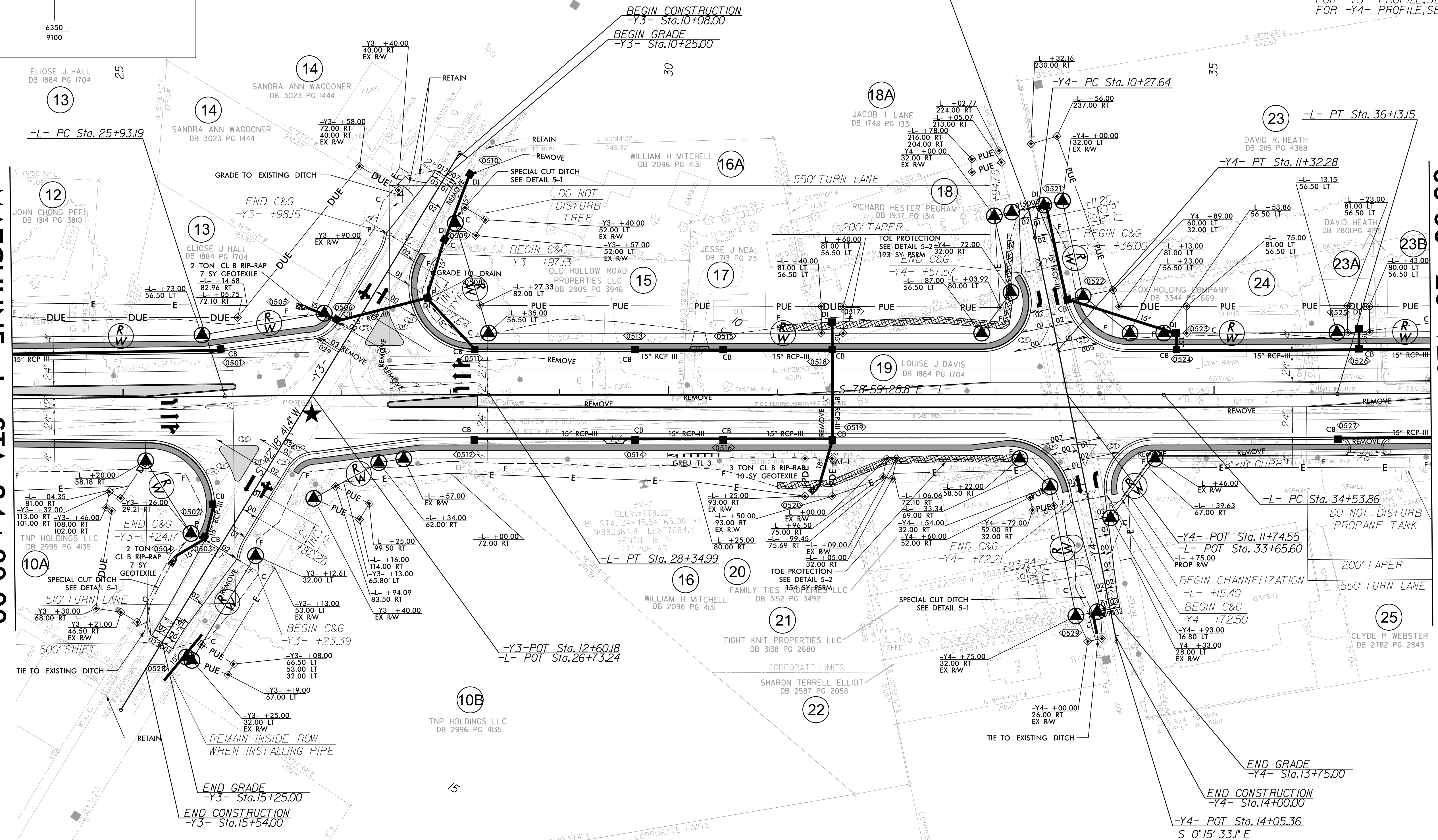

REVISIONS

DC SEP 2023 15:47  
06:52:41 R04:ash-bu.dgn  
taub,labrke

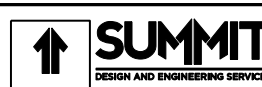

PROJECT REFERENCE NO. <b>U-5824</b>		SHEET NO. <b>6</b>	
RW SHEET NO.			
ROADWAY DESIGN ENGINEER 9/15/2023 SEAL 046981 FAITH E. JANKO		HYDRAULICS ENGINEER 9/15/2023 SEAL 054713 HE YANG	
<b>DOCUMENT NOT CONSIDERED FINAL UNLESS ALL SIGNATURES COMPLETED</b>			
Prepared in the Office of:		 <small>NC FIRM LICENSE NO: P-0339 300 Executive Ct. Hillsborough, NC 27278 (919) 732-3883 (919) 732-6676 (FAX)</small>	

FOR -L- PROFILE, SEE SHEET 13  
FOR -Y5- PROFILE, SEE SHEET 17

<b>L</b>	<b>L</b>
PI Sta 44+05.41	PI Sta 50+18.92
$\Delta = 5^{\circ} 46' 44.5" (RT)$	$\Delta = 4^{\circ} 43' 39.8" (LT)$
$D = 2^{\circ} 29' 28.0"$	$D = 2^{\circ} 29' 28.0"$
$L = 231.99'$	$L = 189.78'$
$T = 116.09'$	$T = 94.95'$
$R = 2,300.00'$	$R = 2,300.00'$
$SE = 3\%$	$SE = 3\%$
$RO = 144'$	$RO = 144'$

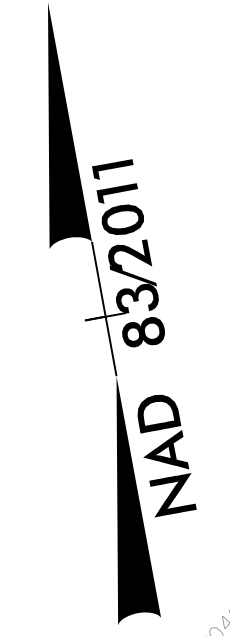

MATCHLINE -L- STA 37+00.00  
(SEE SHEET 5)

MATCHLINE -L- STA 50+00.00  
(SEE SHEET 7)

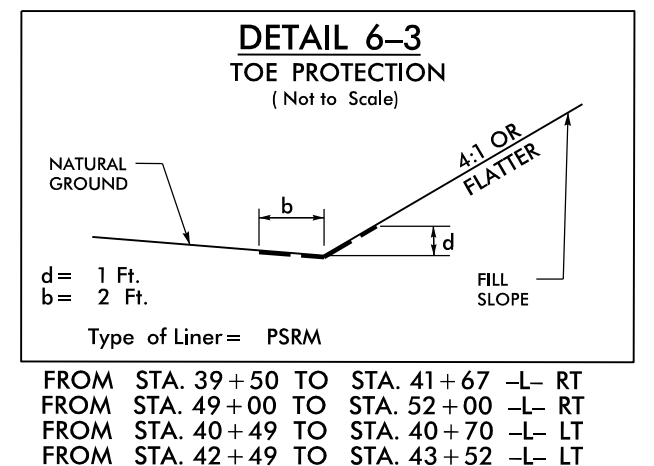
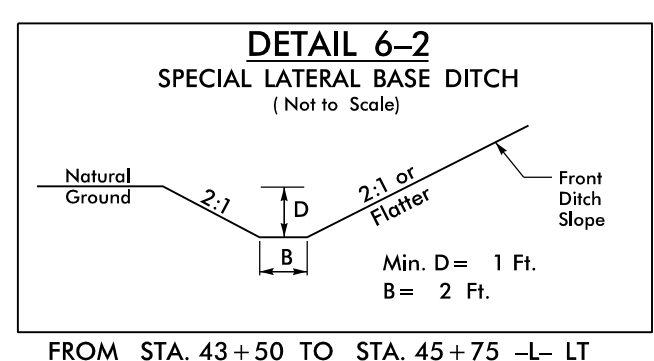
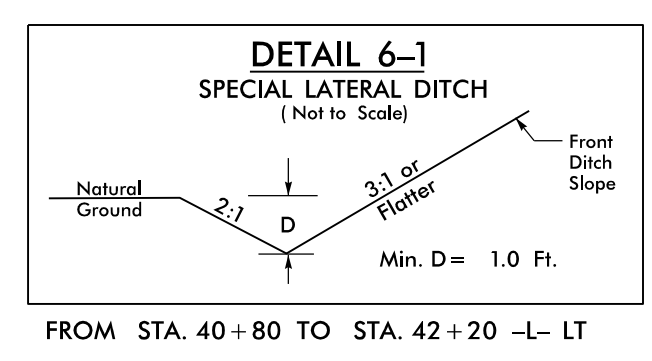
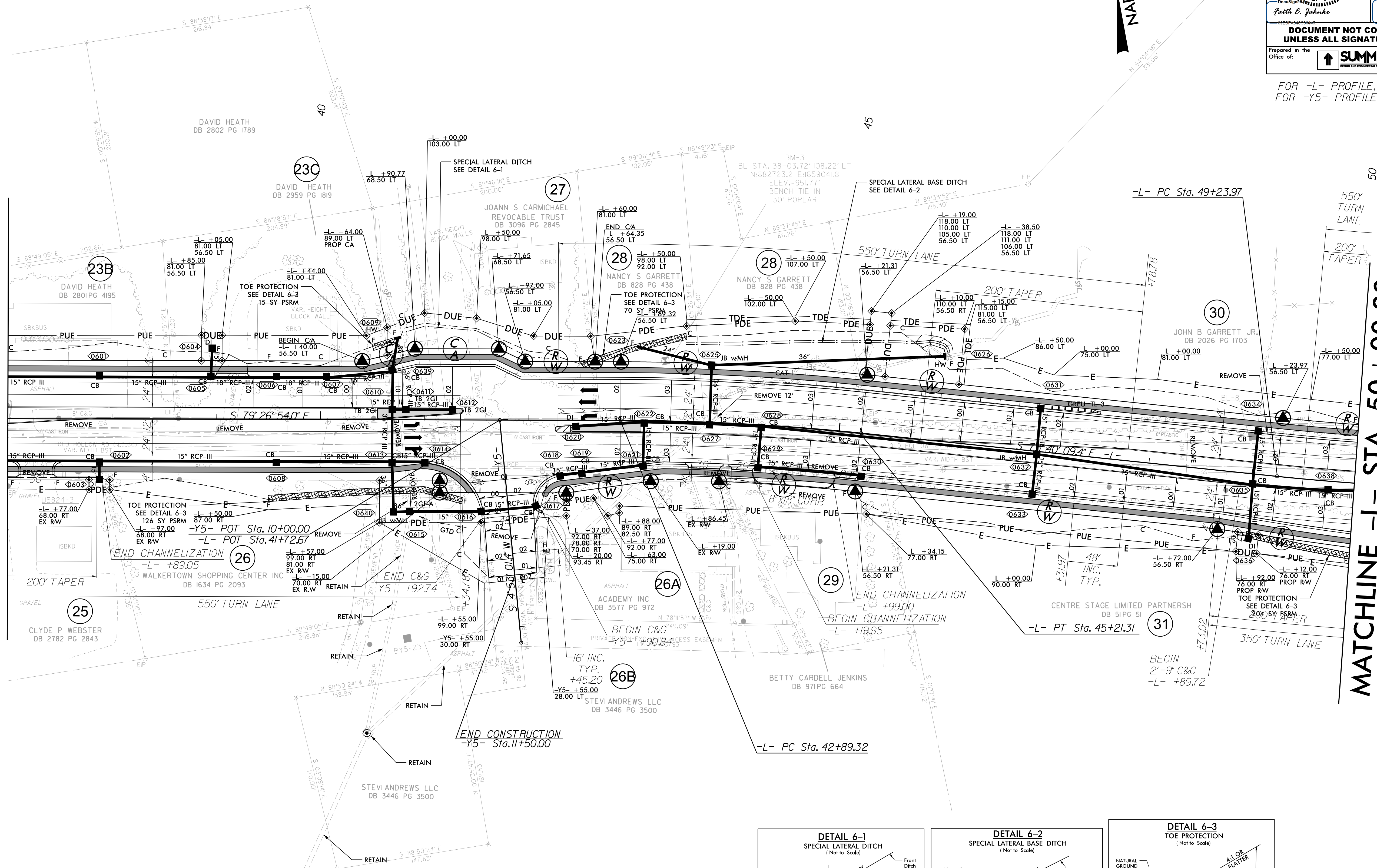

REVISIONS

8.17.17.99

06-SEP-2023 15:47  
06:32 L. Rowash Edgan  
faub, labike



PROJECT REFERENCE NO. <b>U-5824</b>	SHEET NO. <b>7</b>
RW SHEET NO.	
ROADWAY DESIGN ENGINEER 9/15/2023 SEAL 046981 PAUL E. JANKO	HYDRAULICS ENGINEER 9/15/2023 SEAL 054713 HE YANG
<b>DOCUMENT NOT CONSIDERED FINAL UNLESS ALL SIGNATURES COMPLETED</b>	
Prepared in the Office of: <b>SUMMIT</b> NC FIRM LICENSE NO: P-0339 300 EXECUTIVE CT HILLSBOROUGH, NC 27278 (919) 732-3881 (919) 732-6676 (FAX)	

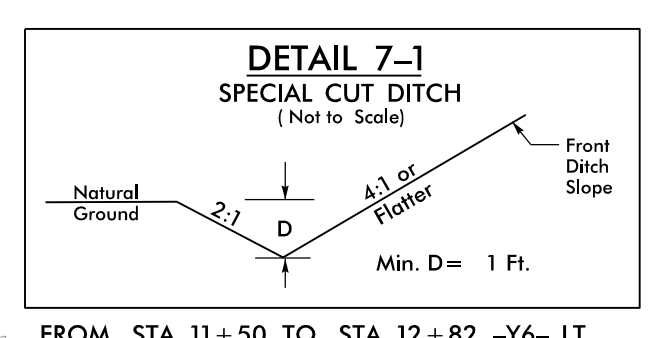

**-Y7B-**  
 PI Sta 12+35.76  
 $\Delta = 12' 41'' 34.4''$  (RT)  
 $D = 5' 43'' 46.5''$   
 $L = 221.53'$   
 $T = 111.22'$   
 $R = 1,000.00'$

**-L-**  
 PI Sta 50+18.92  
 $\Delta = 4' 43'' 39.8''$  (LT)  
 $D = 2' 29'' 28.0''$   
 $L = 189.78'$   
 $T = 94.95'$   
 $R = 2,300.00'$   
 $SE = 3\%$   
 $RO = 144'$

**-L-**  
 PI Sta 54+10.21  
 $\Delta = 9' 11'' 11.0''$  (RT)  
 $D = 1' 33'' 09.8''$   
 $L = 59.63'$   
 $T = 296.45'$   
 $R = 3,690.00'$   
 $SE = 2\%$   
 $RO = 96'$

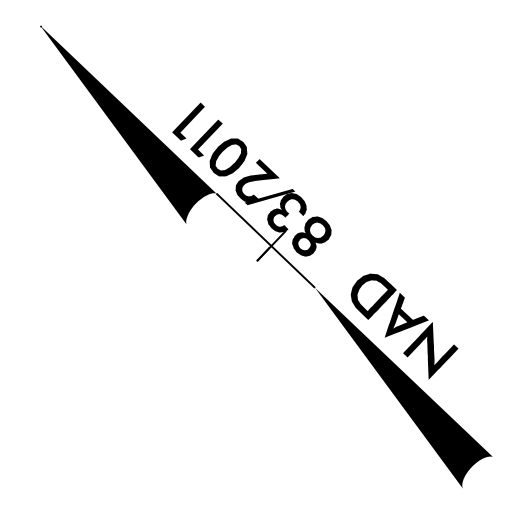
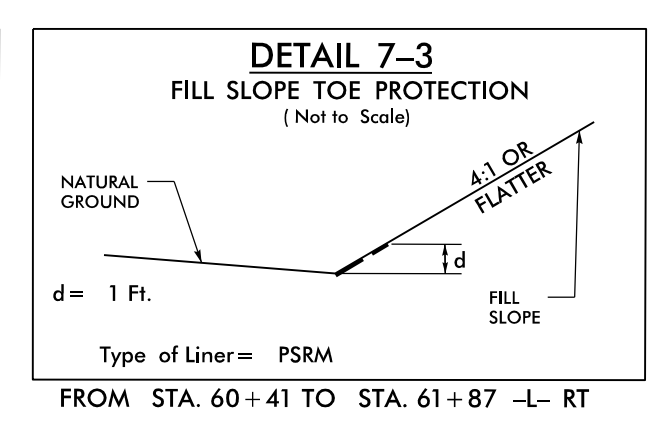
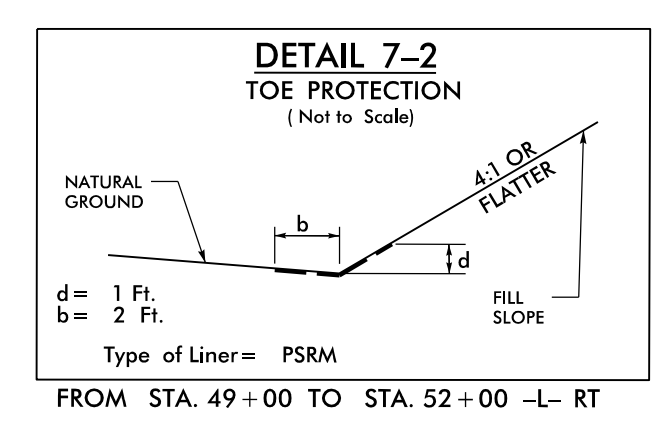

**MATCHLINE -L- STA 50+00.00  
(SEE SHEET 6)**

**MATCHLINE -L- STA 63+00.00  
(SEE SHEET 8)**

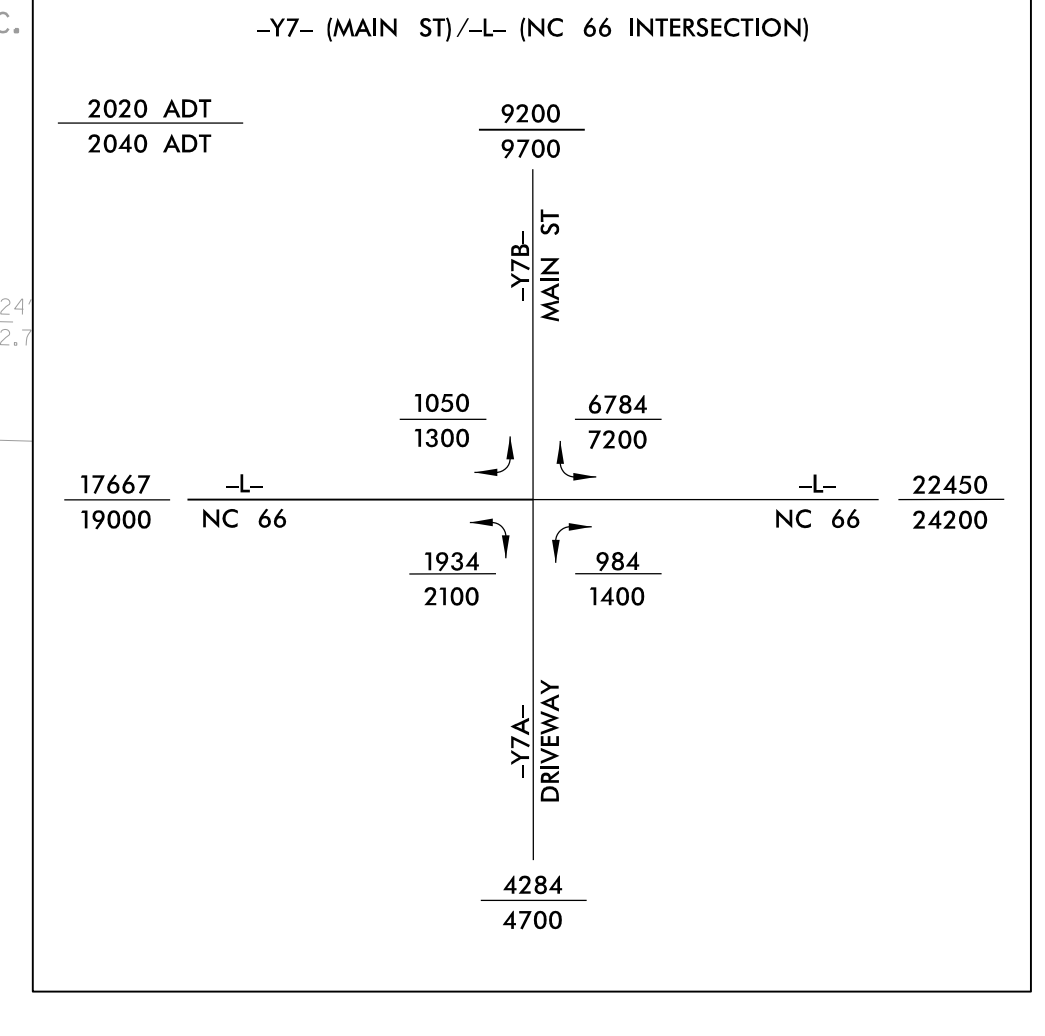
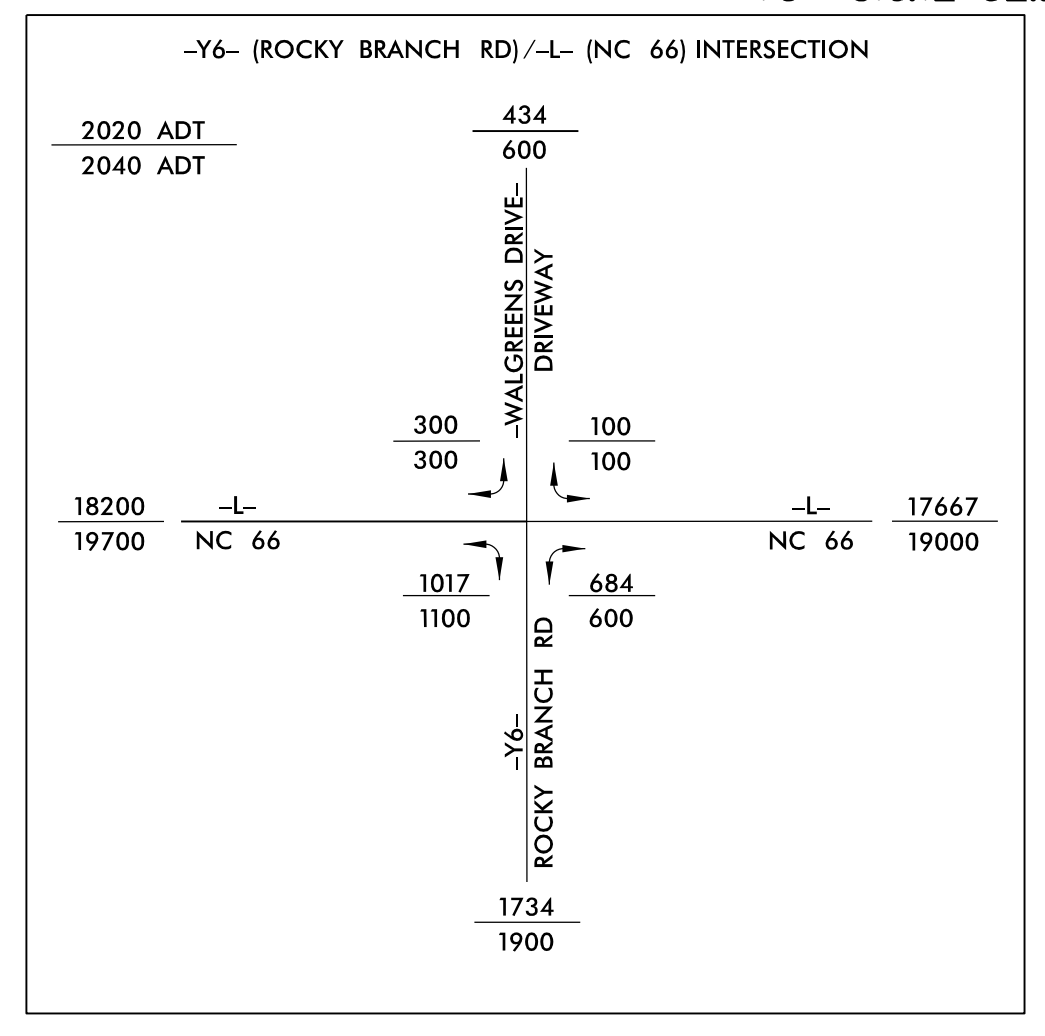
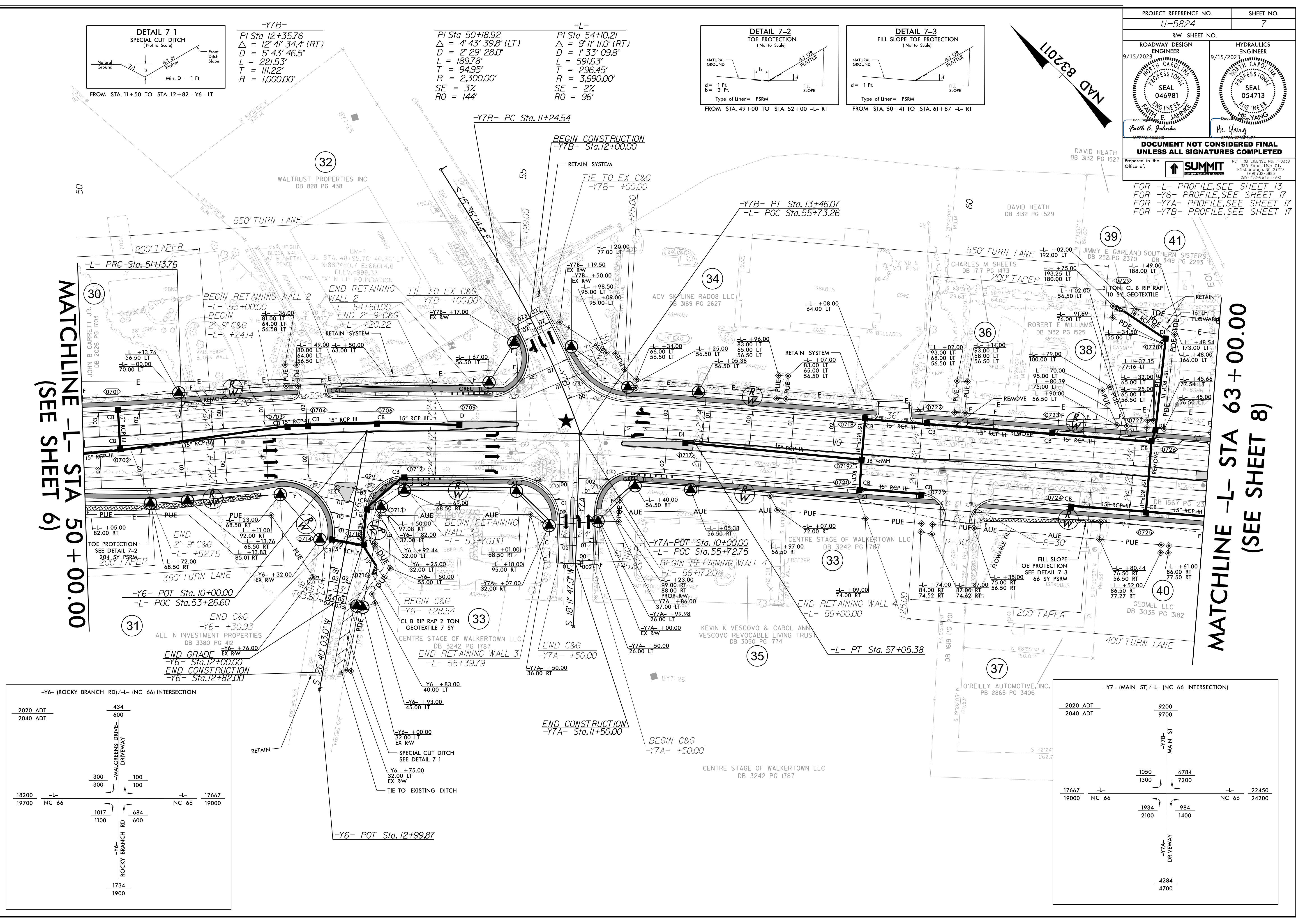

REVISIONS

06-SEP-2023 15:47  
D:\63\1\_Road\ash\c.dgn  
toubi\labbe