

REFERENCE PAVEMENT MARKING PLANS FOR  
-Y- LINE PAVEMENT MARKING LOCATIONS  
AND DIMENSIONS NOT OTHERWISE SHOWN.

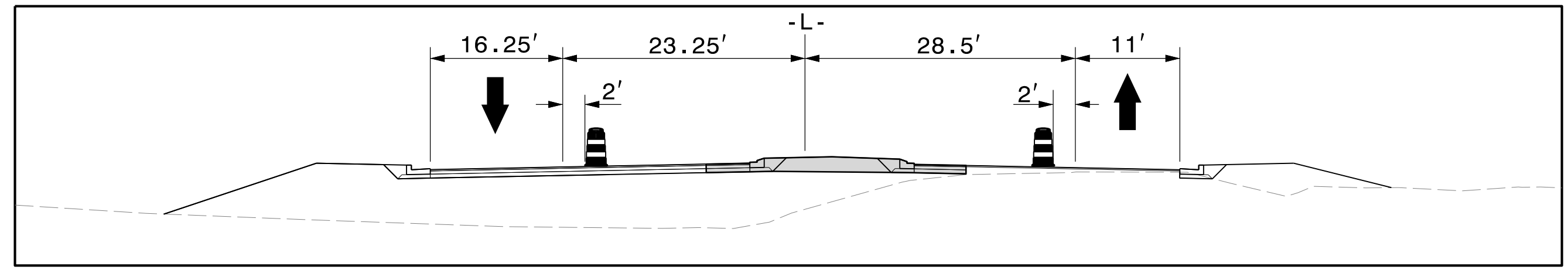

B-B  
STA. 32+00

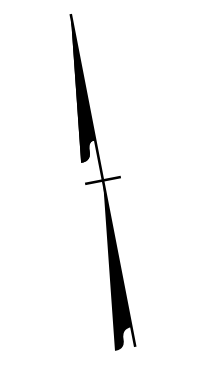

MATCHLINE -L- STA 24+00.00  
(SEE TMP-9A)

MATCHLINE -L- STA 37+00.00  
(SEE TMP-9C)

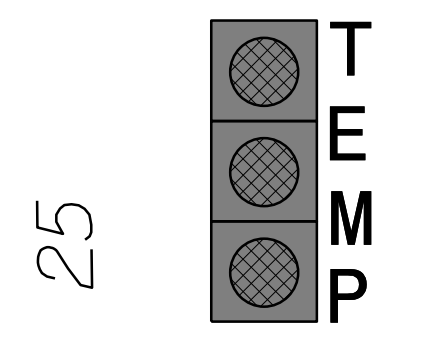
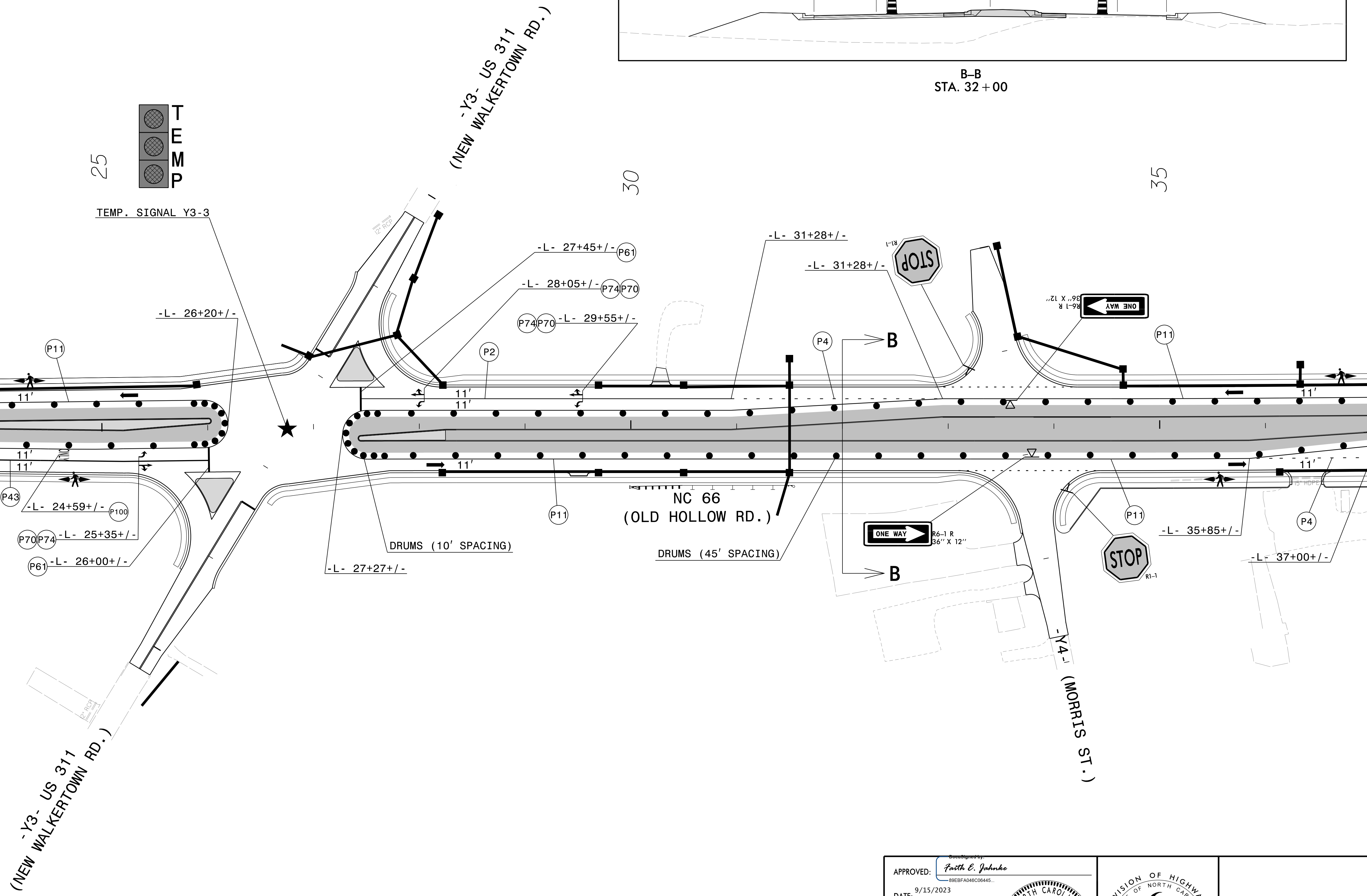

TEMP. SIGNAL Y3-3

DRUMS (10' SPACING)

DRUMS (45' SPACING)

WORK AREA

APPROVED: *Faith E. Jahnke*  
DATE: 9/15/2023

SEAL

DOCUMENT NOT CONSIDERED FINAL  
UNLESS ALL SIGNATURES COMPLETED

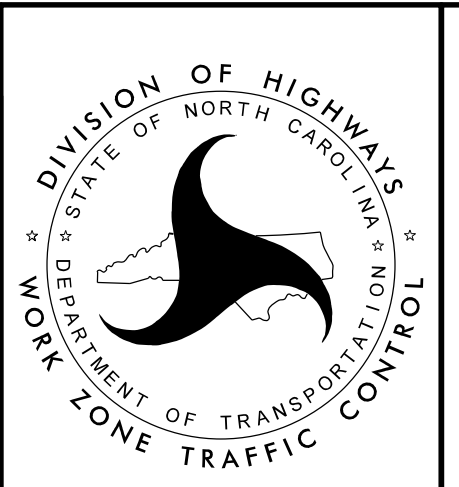

DIVISION OF HIGHWAYS  
STATE OF NORTH CAROLINA  
DEPARTMENT OF TRANSPORTATION  
WORK ZONE TRAFFIC CONTROL

PHASE III  
DETAIL

15-AUG-2023 14:56  
U5824-TC-TMP-9B.dgn  
faith.jahnke