

SEE ROADWAY DETAIL SHEETS FOR  
TEMPORARY PAVEMENT DETAILS

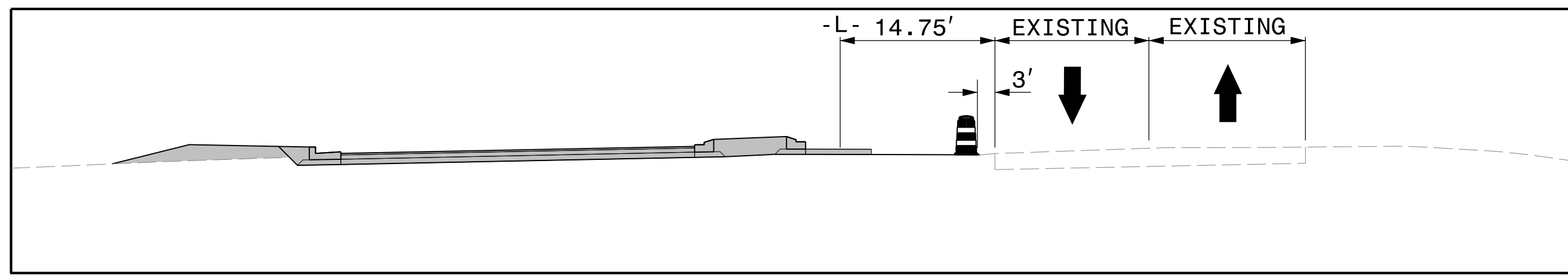

A-A  
STA. 22+00

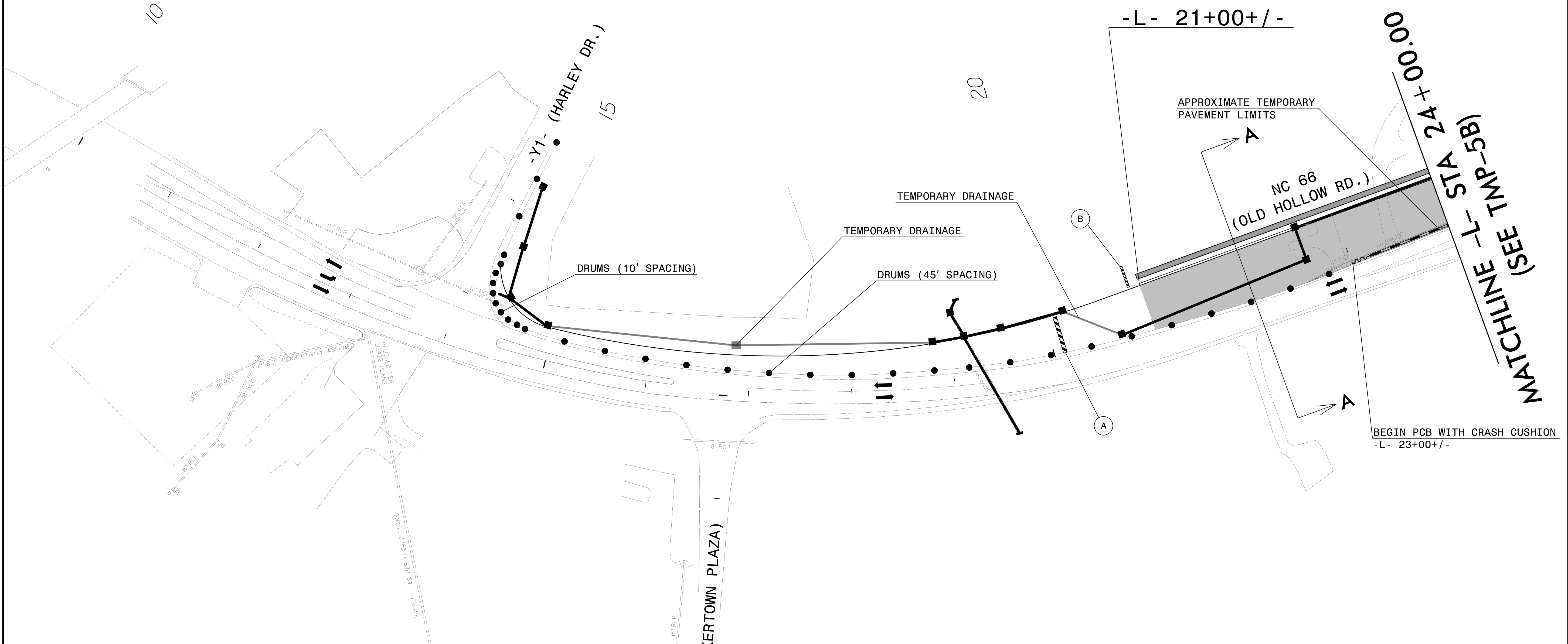
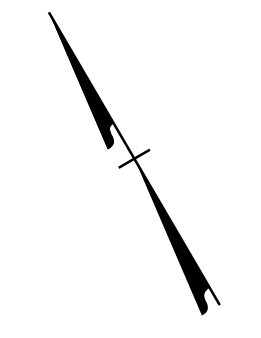

APPROXIMATE TEMPORARY  
PAVEMENT LIMITS  
A  
B  
A  
A  
-L- 21+00+/-  
-L- 24+00.00  
-L- STA 24+00.00  
MATCHLINE -L- STA 24+00.00  
(SEE TMP-5B)

BEGIN PCB WITH CRASH CUSHION  
-L- 23+00+/-

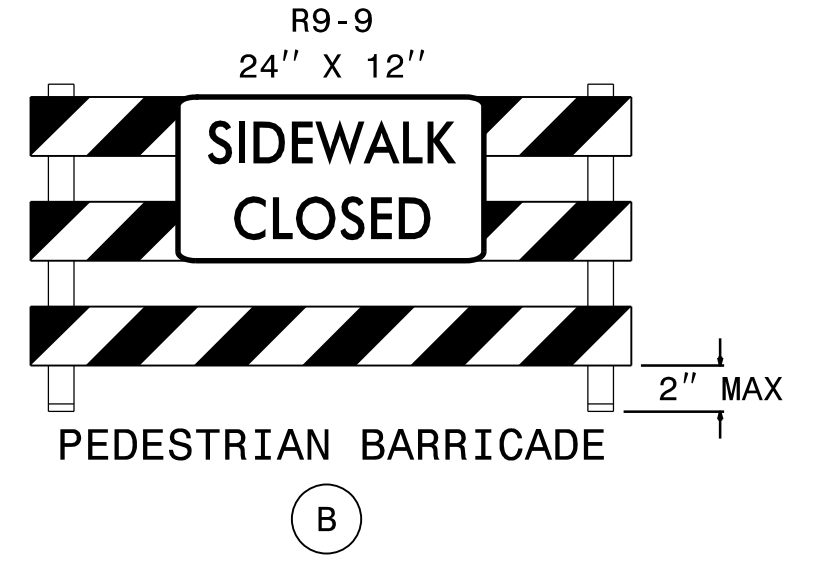
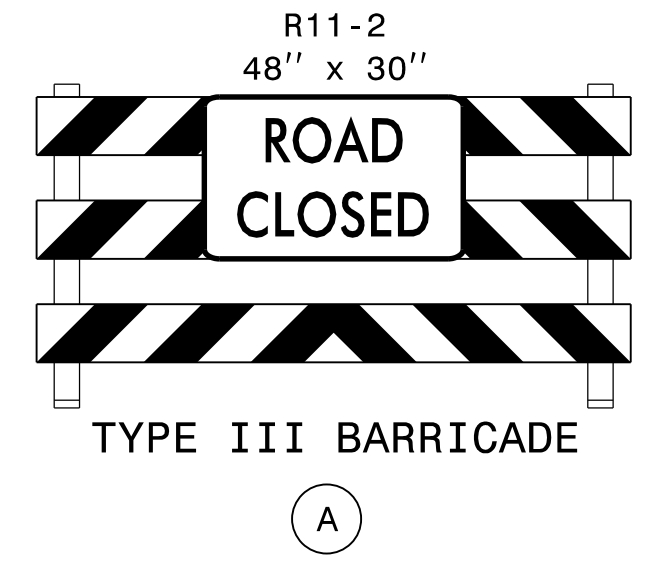
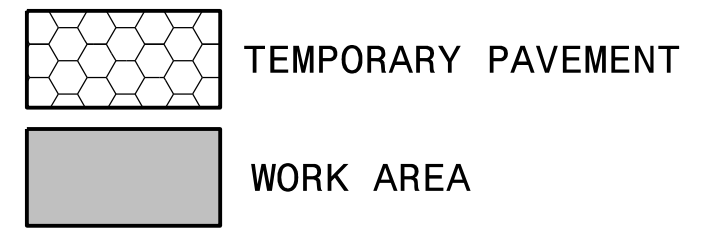

APPROVED: *Faith E. Jahnke*  
DATE: 9/15/2023

Seal of Faith E. Jahnke, Professional Engineer, No. 046981, State of North Carolina.

SEAL

**DOCUMENT NOT CONSIDERED FINAL  
UNLESS ALL SIGNATURES COMPLETED**

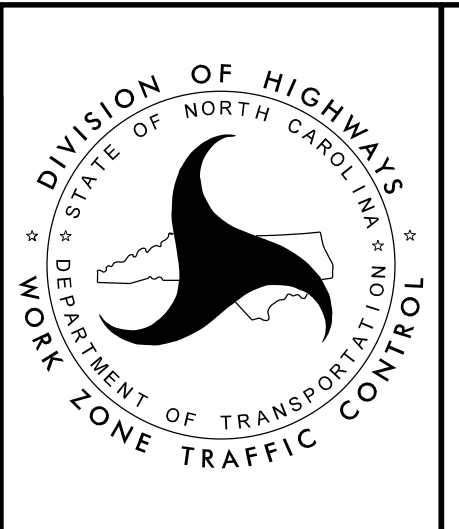

PHASE IA  
DETAIL

15-AUG-2023 14:54  
U5824-1C-TMP-5A.dgn  
Faith.Jahnke