

NOTES

FINAL JOINT SEALS SHALL NOT BE INSTALLED UNTIL THE OVERLAY OR SEALANT WORK IS COMPLETE.

THE CONTRACTOR SHALL FIELD VERIFY THE EXISTING JOINT OPENING PRIOR TO ORDERING JOINT SEAL MATERIAL. IF THE ACTUAL JOINT OPENING VARIES FROM THE OPENING INDICATED IN THE DETAILS BY MORE THAN 1/4", NOTIFY THE ENGINEER.

THE MANUFACTURER IS TO PROVIDE THE NOMINAL UNCOMPRESSED SEAL WIDTH OF THE FOAM JOINT SEAL FOR THE SIZE OF THE OPENING ON THE PLANS AND ACCOMODATE THE MINIMUM EXPANSION SHOWN ON THE PLANS.

FOAM JOINTS SHALL BE INSTALLED AS PER THE MANUFACTURER'S RECOMMENDATIONS.

THE CONTRACTOR SHALL TAKE CARE DURING JOINT REHAB OPERATIONS NOT TO DROP ANY MATERIAL BELOW THE BRIDGE, WITHOUT PROTECTIVE DEVICES BELOW TO CATCH THE MATERIAL. ANY MATERIAL THAT FALLS BELOW THE BRIDGE SHALL BE CONTAINED, REMOVED AND DISPOSED OF BY THE CONTRACTOR AT NO EXTRA COST TO THE DEPARTMENT. IF THE ENGINEER DETERMINES THAT THE PROTECTIVE DEVICES ARE NOT ADEQUATE OR NOT BEING EMPLOYED, THE WORK SHALL BE SUSPENDED UNTIL ADEQUATE PROTECTION IS PROVIDED.

THE CONTRACTOR WILL NOT BE PERMITTED TO FORM THE JOINTS IN LIEU OF SAWING THE JOINT.

THE INSTALLED FOAM JOINTS SHALL BE WATER TIGHT.

FOR FOAM JOINT SEALS FOR PRESERVATION, SEE SPECIAL PROVISIONS.

THE CONTRACTOR SHALL SAW CUT TO A NOMINAL DEPTH OF 1/2" BUT REINFORCING STEEL SHALL NOT BE DAMAGED. CONTRACTOR SHALL REMOVE SURFACE CONCRETE TO VERIFY THAT SAWCUT DEPTH WILL NOT DAMAGE EXISTING REINFORCING STEEL.

QUANTITIES SHOWN IN THE ELASTOMERIC CONCRETE FOR PRESERVATION TABLE ARE BASED ON THE MINIMUM JOINT DEMOLITION SHOWN.

FINAL SURFACE OF THE JOINT DEMOLITION AREA PRIOR TO PLACEMENT OF CONCRETE REPAIR MATERIAL OR ELASTOMERIC CONCRETE SHALL BE REASONABLY FLAT AND LEVEL. THE ENGINEER SHALL DETERMINE ACCEPTABILITY OF THE SURFACE.

FOR EXCAVATION BELOW THE BOTTOM OF PLANNED JOINT DEMOLITION, CONCRETE FOR DECK REPAIR SHALL BE PLACED IN THE EXCAVATED AREA TO THE ELEVATION AT THE BOTTOM OF THE PROPOSED ELASTOMERIC CONCRETE FOR PRESERVATION HEADERS SHOWN.

FOR BRIDGE JOINT DEMOLITION, SEE SPECIAL PROVISIONS.

FOR ELASTOMERIC CONCRETE FOR PRESERVATION, SEE SPECIAL PROVISIONS.

FOR CONCRETE DECK REPAIR FOR SILANE DECK TREATMENT, SEE SPECIAL PROVISIONS.

SECTION A-A
(TYP. AT END BENTS)

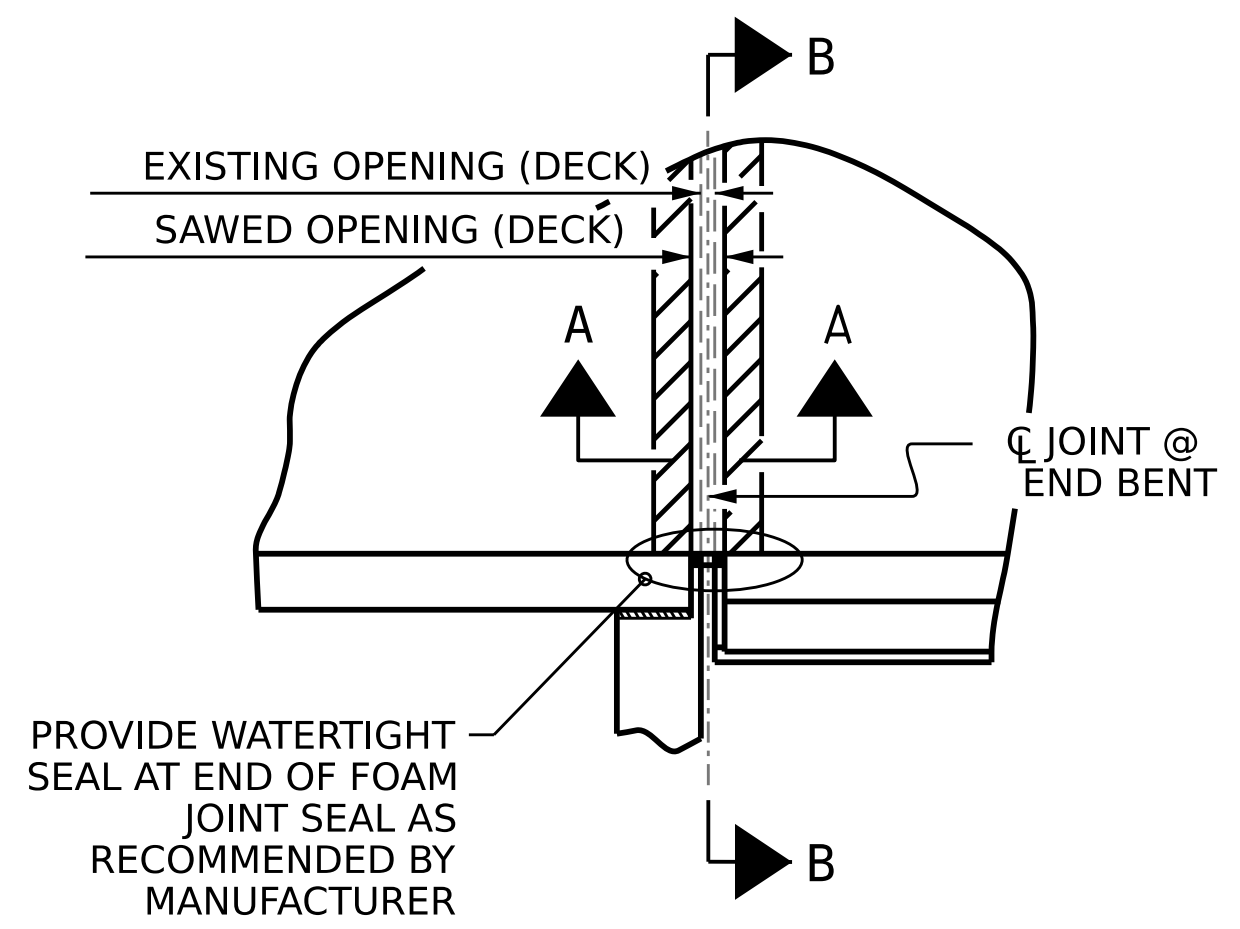

PLAN
(@ END BENTS)

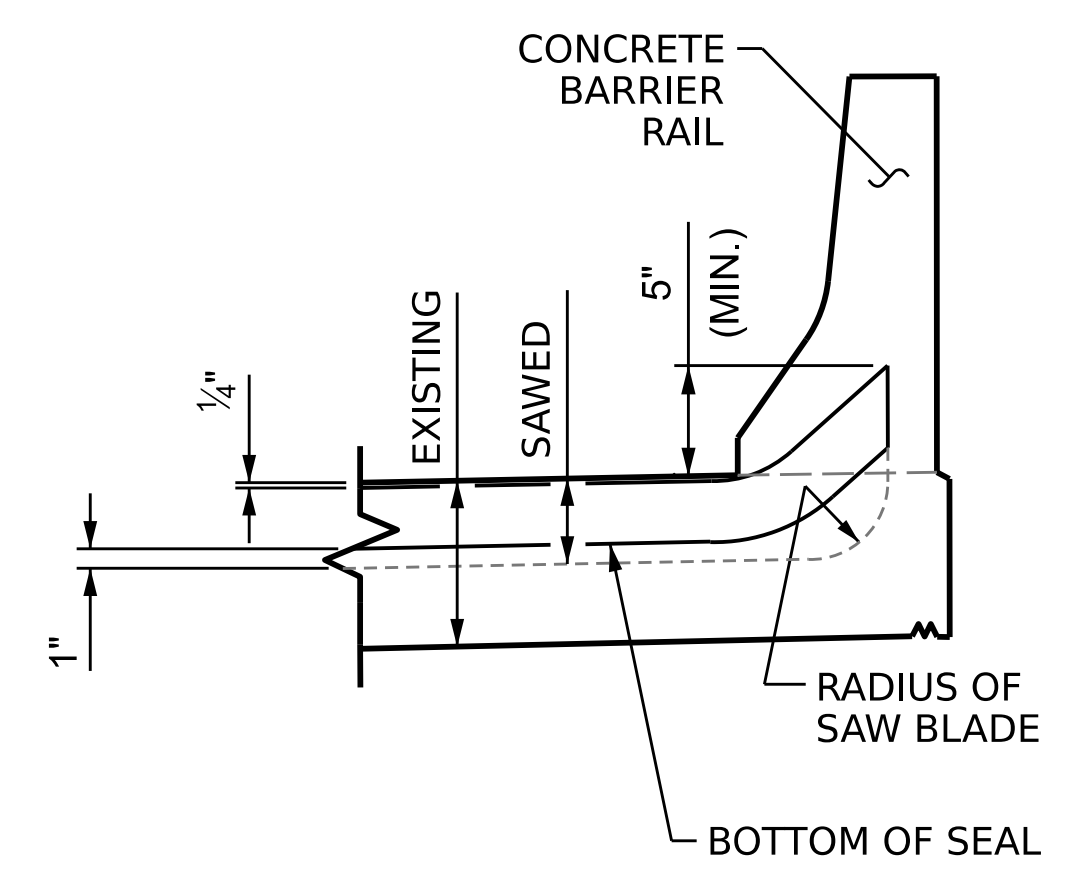

SECTION B-B

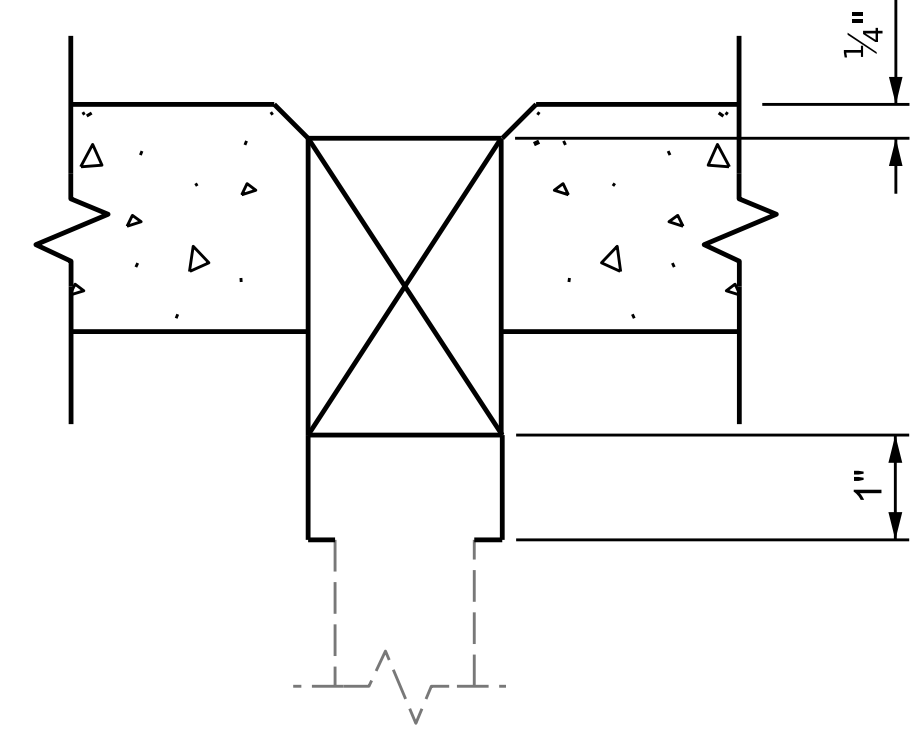

DETAIL 'A'

JOINT SEAL DETAILS

JOINT REPAIR QUANTITY TABLE

	ESTIMATED (LIN. FT.)	ACTUAL (LIN. FT.)
FOAM JOINT SEALS FOR PRESERVATION	84.0	

ELASTOMERIC CONCRETE FOR PRESERVATION

LOCATION	ESTIMATED (CU. FT.)	ACTUAL (CU. FT.)
END BENT 1	12.3	
END BENT 2	12.3	
TOTAL	24.6	

SAWED JOINT OPENING TABLE

LOCATION	SAWED JOINT OPENING (PERPENDICULAR TO JOINT)		
	AT 45°	AT 60°	AT 90°
END BENT 1	2 3/16"	2"	1 5/8"
END BENT 2	2 3/16"	2"	1 5/8"

DRAWN BY : S. T. SANDOR DATE : 1/17/23
 CHECKED BY : W. C. SMITH DATE : 5/23/23
 DESIGN ENGINEER OF RECORD : DATE :

PROJECT NO. **I-6036**
BRUNSWICK COUNTY
 BRIDGE NO. **090237**

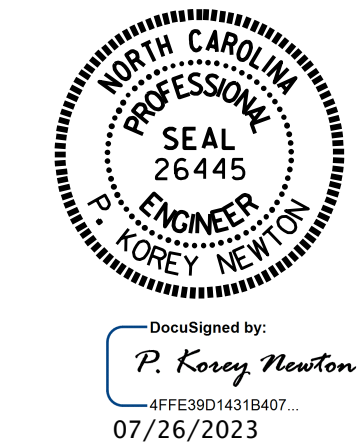

STATE OF NORTH CAROLINA
 DEPARTMENT OF TRANSPORTATION
 RALEIGH

JOINT REPAIR DETAILS

REVISIONS						SHEET NO.
NO.	BY:	DATE:	NO.	BY:	DATE:	S6-4
1			3			TOTAL SHEETS
2			4			4

DOCUMENT NOT CONSIDERED FINAL UNLESS ALL SIGNATURES COMPLETED