

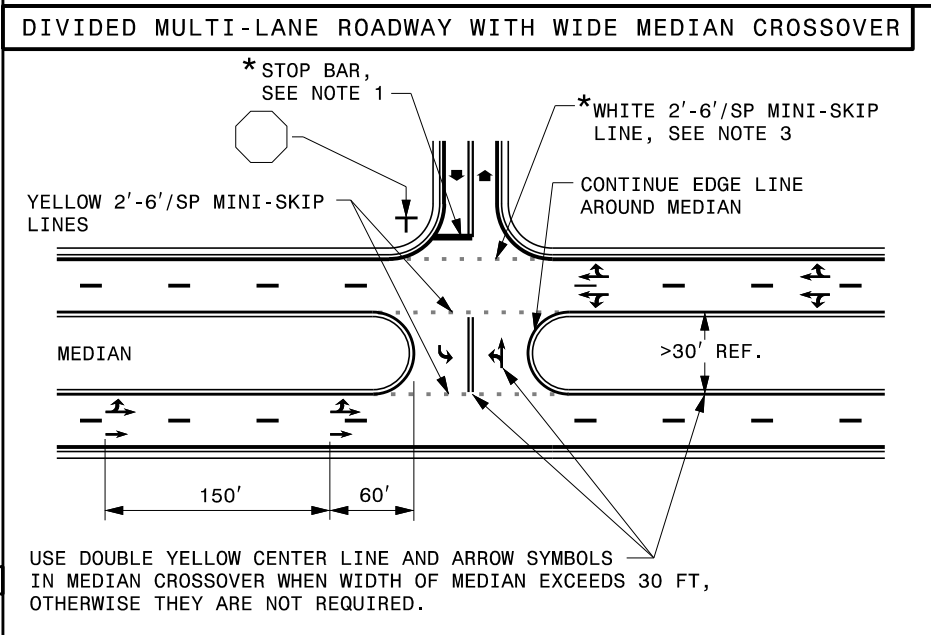

STATE OF NORTH CAROLINA DEPT. OF TRANSPORTATION DIVISION OF HIGHWAYS RALEIGH, N.C. ENGLISH DETAIL DRAWING FOR PAVEMENT MARKINGS INTERSECTIONS SHEET 2 OF 2 1205D04

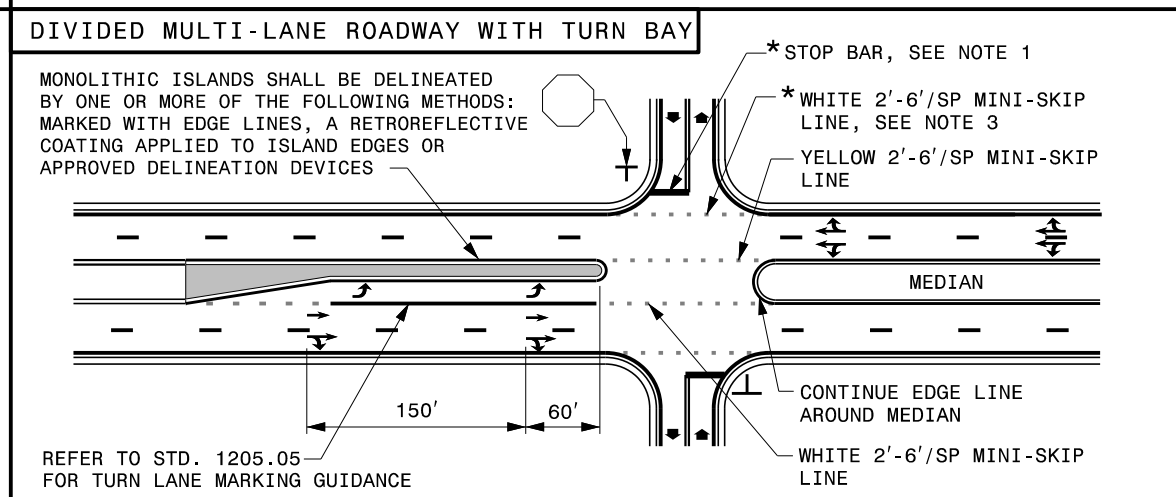
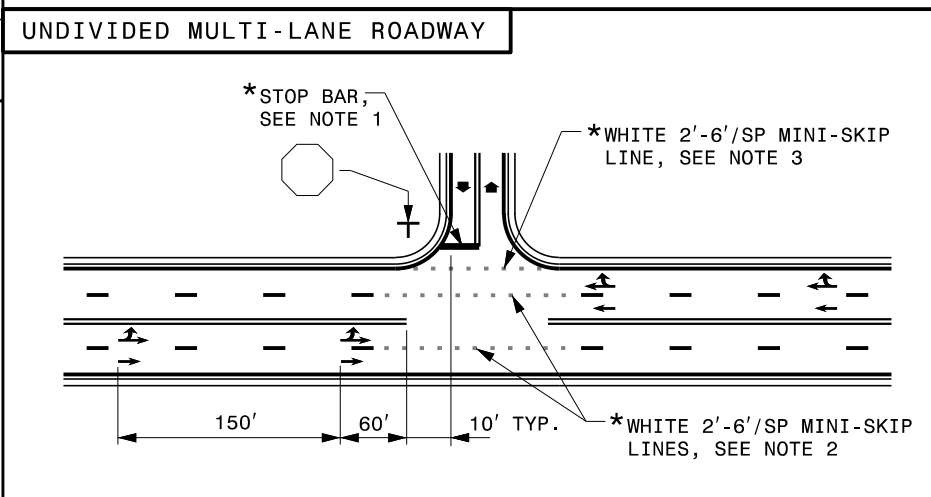
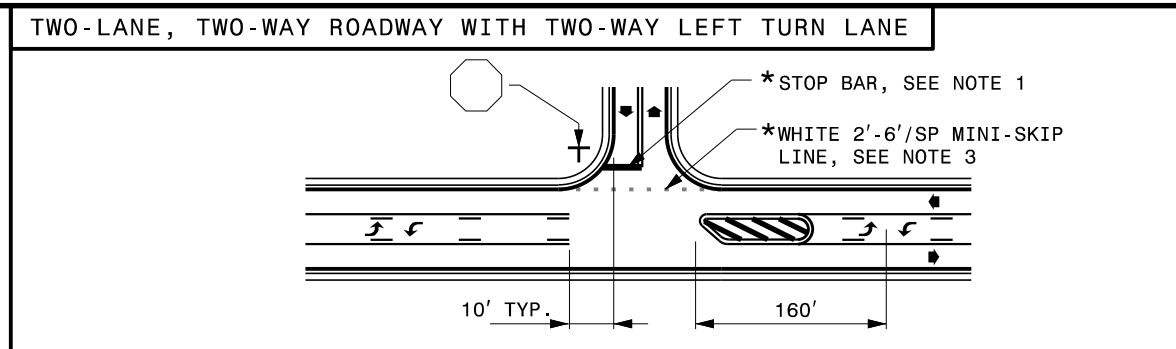
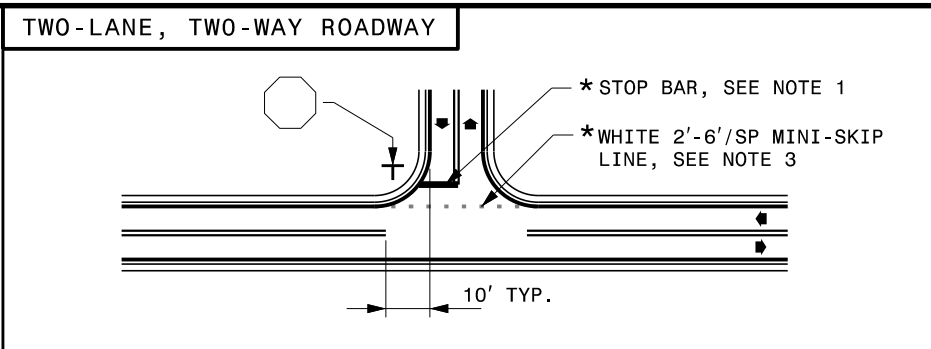

GENERAL NOTES: 1- PLACEMENT OF STOP BARS AT NON-SIGNALIZED INTERSECTIONS IS OPTIONAL... 2- MINI-SKIP LANE LINE EXTENSIONS SHOULD BE USED AT INTERSECTIONS THAT HAVE REDUCED VISIBILITY... 3- MINI-SKIP EDGE LINE EXTENSIONS MAY BE PLACED THROUGH INTERSECTIONS AND MAJOR DRIVEWAYS... 4- REFER TO ROADWAY STANDARD DRAWINGS 1205.01, 1205.02, 1205.05, 1205.08 AND 1205.09 FOR ADDITIONAL PAVEMENT MARKING GUIDANCE.

LEGEND table with symbols for STOP SIGN, STATIONARY SIGN, DIRECTION OF TRAFFIC FLOW, PAVEMENT MARKING SYMBOLS, and OPTIONAL.

STATE OF NORTH CAROLINA DEPT. OF TRANSPORTATION DIVISION OF HIGHWAYS RALEIGH, N.C. ENGLISH DETAIL DRAWING FOR PAVEMENT MARKINGS INTERSECTIONS SHEET 2 OF 2 1205D04

REVISED PAVEMENT MARKING ROADWAY STANDARD DRAWING

U:\8\1371\Standards Group\Standards and Drawings\Drawings\2018 Standard Dwg\Division 12 Final\2050402\_08-13-19.dgn User:dstokes