

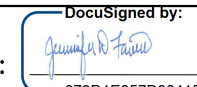

TIP NO. C-5621	SHEET NO. SIGN-1
APPROVED:  07901E857D98415	
DATE: 7/10/2023	
SEAL 	
DOCUMENT NOT CONSIDERED FINAL UNLESS ALL SIGNATURES COMPLETED	

**STATE OF NORTH CAROLINA
DEPARTMENT OF TRANSPORTATION**

**SIGNING PLAN
MECKLENBURG COUNTY**

**LOCATION: DUAL ROUNDABOUTS NORTH AND SOUTH OF
SR 5544 (CATAWBA AVE.) AND
US 21 INTERSECTION IN CORNELIUS**

T.I.P.: C-5621

CONTRACT: C204495

ROADWAY STANDARD DRAWING

THE FOLLOWING ROADWAY STANDARDS AS APPEAR IN "ROADWAY STANDARD DRAWINGS" - PROJECT SERVICES UNIT - N.C. DEPARTMENT OF TRANSPORTATION - RALEIGH, N.C., DATED JANUARY 2018 ARE APPLICABLE TO THIS PROJECT AND BY REFERENCE HEREBY ARE CONSIDERED A PART OF THESE PLANS:

STD. NO.	TITLE
901.10	TYPE 'A' SIGNS
901.50	ARROWS AND SHIELDS
901.70	SIGN STRINGERS AND SUPPORT SPACING
901.80	SIGN MOUNTING DETAILS - FOR TYPE A AND TYPE B SIGNS
903.10	GROUND MOUNTED SIGN SUPPORTS
904.10	ORIENTATION OF GROUND MOUNTED SIGNS
904.30	SUPPLEMENTAL SIGN MOUNTING
904.50	MOUNTING OF TYPE 'D', 'E' AND 'F' SIGNS ON 'U' CHANNEL POSTS
910.40	SINGLE/TWO LANE ROUNDABOUT WITH PEDESTRIAN

GENERAL NOTES

- ALL TYPE 'D' SIGNS SHALL BE MOUNTED ON TWO U-CHANNEL POSTS UNLESS OTHERWISE INDICATED ON THE PLANS.
- IF REMOVAL OR RELOCATION OF SIGNS ON PRIVATE STREET (NON-STATE MAINTAINED) IS REQUIRED DUE TO CONSTRUCTION, THE CONTRACTOR SHALL INFORM THE ENGINEER. THE WORK WILL BE COMPLETED BY OTHERS.
- WHEN NOT STATIONED OR DIMENSIONED ON PLANS, ALL 'E' AND 'F' SIGNS SHALL BE FIELD LOCATED BY THE ENGINEER
- ALL EXISTING SIGNS ON "U" CHANNEL POST WITHIN THE PROJECT LIMITS SHALL BE REMOVED AND DISPOSED OF UNLESS OTHERWISE NOTED ON PLANS.
- WHEN EXISTING SIGNS ARE REMOVED AND INSTALLED ON NEW SUPPORTS, THE RE-ERECTION SHALL IMMEDIATELY FOLLOW THE REMOVAL.
- THE BACKGROUND FOR TYPE E & F SIGNS SHALL BE TYPE C REFLECTIVE SHEETING.
- DO NOT BEGIN FABRICATION FOR TYPES A & B SIGNS MOUNTED ON OVERHEAD STRUCTURES OR STEEL SUPPORTS UNTIL "S" DIMENSIONS HAVE BEEN FIELD VERIFIED.
- SIGNS FURNISHED BY STATE.
- CONFIRM IN WRITING AT LEAST 4 MONTHS IN ADVANCE, THE ACTUAL DATE THE DEPARTMENT FURNISHED SIGNS WILL BE REQUIRED

SUMMARY OF QUANTITIES

ITEM NO.	ITEM DESCRIPTION	QUANTITY	UNIT
DESC. NO.	SECT. NO.		
4048000000	902	2	CY
4060000000	903	2142	LB.
4072000000	903	950	L.F.
4096000000	904	2	EA.
4102000000	904	95	EA.
4108000000	904	35	EA.
4110000000	904	3	EA.
4116100000	904	6	EA.
4116100000	904	6	EA.
4152000000	907	3	EA.
4155000000	907	37	EA.
4192000000	907	7	EA.

INDEX

SHEET NO.	DESCRIPTION
SIGN-1	TITLE SHEET
SIGN-1A	TYPE "A" GROUND MOUNTED SIGN SUPPORT INFORMATION
SIGN-2-2A	E AND F SHEETS
SIGN-3-3A	SIGN DESIGNS
SIGN-4-6	PROPOSED SIGNS
SIGN-7-9	EXISTING SIGNS

PLAN SUBMITTED TO: NCDOT

SEAN EPPERSON, PE - DIVISION PROJECT DEVELOPMENT ENGINEER

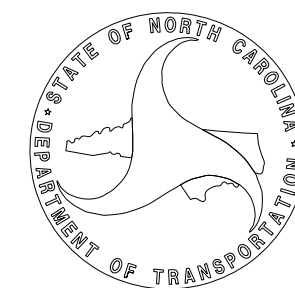

PLAN PREPARED BY: RS&H

JENNIFER D. FARINO, P.E. PROJECT ENGINEER
NIKI E. AVGERINOS, E.I. PROJECT DESIGN ENGINEER

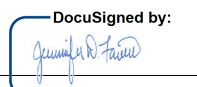
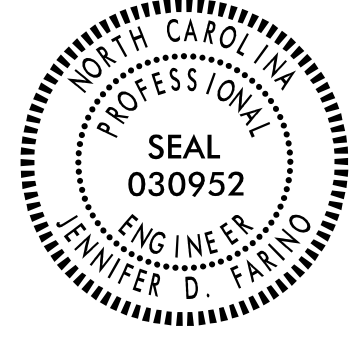

TIP NO. C-5621	SHEET NO. SIGN-1A
APPROVED:  DATE: 7/10/2023	
	
DOCUMENT NOT CONSIDERED FINAL UNLESS ALL SIGNATURES COMPLETED	

Version: 3.1 Posted: 6/2/2017

NUMBER	SIGN TYPE	SIGN SIZE (in.)			ROADWAY STATION	NUMBER OF SUPPORTS	BEAM SECTION	SUPPORT TYPE BA or S	OMNI COUPLER	ATTACHMENT METHOD	MOUNTING METHOD	HORIZONTAL CLEARANCE* (ft.)	SUPPORT SPACING	LENGTH (ft)			LEFT SUPPORT (ft)			CENTER SUPPORT (ft)			RIGHT SUPPORT (ft)			SUPPORT WEIGHTS		FOOTINGS				FIELD VERIFIED SEE NOTE 2 (mm/dd/yy)																	
		w	x	h										SNS HT	MTG HT	EMBED-MENT	S	L	LENGTH	S	L	LENGTH	S	L	LENGTH	B/A (lbs.)	SIMPLE (lbs.)	DIAMETER (ft.)	DEPTH (ft.)	REINFORCED (c.y.)	PLAIN (c.y.)																		
		101	A	114										x	102	1235	2	W6x12	BA	N/A	N/A	N/A	12.00	5.57	8.50	7.61	3.5	-0.61	15.50	19.00	0.00		0.00	0.00	2.16	18.27	21.77	567.24	0	1.5	4	0.52	0.00						
102	A	126	x	162	1352	2	W6x16	BA	N/A	N/A	N/A	13.00	6.15	13.50	7.02	4.5	-0.02	20.50	25.00	0.00	0.00	0.00	3.05	23.57	28.07	943.12	0	1.5	5	0.65	0.00	_____																	
103	A	108	x	150	1180	2	W6x12	BA	N/A	N/A	N/A	12.00	5.27	12.50	7.79	3.5	-0.79	19.50	23.00	0.00	0.00	0.00	-0.68	19.61	23.11	631.30	0	1.5	4	0.52	0.00	_____																	
																							TOTAL	TOTAL	TOTAL	TOTAL																							
																							2141.66	0.00	1.70	0.00																							
																							USE:	2142.00	0.00	2.00	0.00																						

NOTES

- DIMENSION "S" REPRESENTS AN INCREASE (+), OR A DECREASE (-) IN POLE LENGTH, RELATIVE TO THE ELEVATION OF THE EDGE OF TRAVEL LANE.
- FIELD VERIFICATIONS SHALL BE REQUIRED FOR ALL SUPPORTS, SEE (*) ARTICLE 903-3. FABRICATORS SHALL BE AISC CERTIFIED IN CATEGORY 1, SEE (*) ARTICLE 1072-1. (*) = N.C.D.O.T. STANDARD SPECIFICATIONS FOR ROADS AND STRUCTURES
- PLAN LOCATIONS FOR EXISTING UTILITIES ARE BASED ON THE BEST AVAILABLE INFORMATION AND, THEREFORE MAY NOT BE PRECISELY ACCURATE. THEREFORE, IT IS INCUMBENT UPON THE CONTRACTOR TO DETERMINE THE EXACT LOCATION OF UTILITIES BEFORE BEGINNING WORK IN A LOCATION.

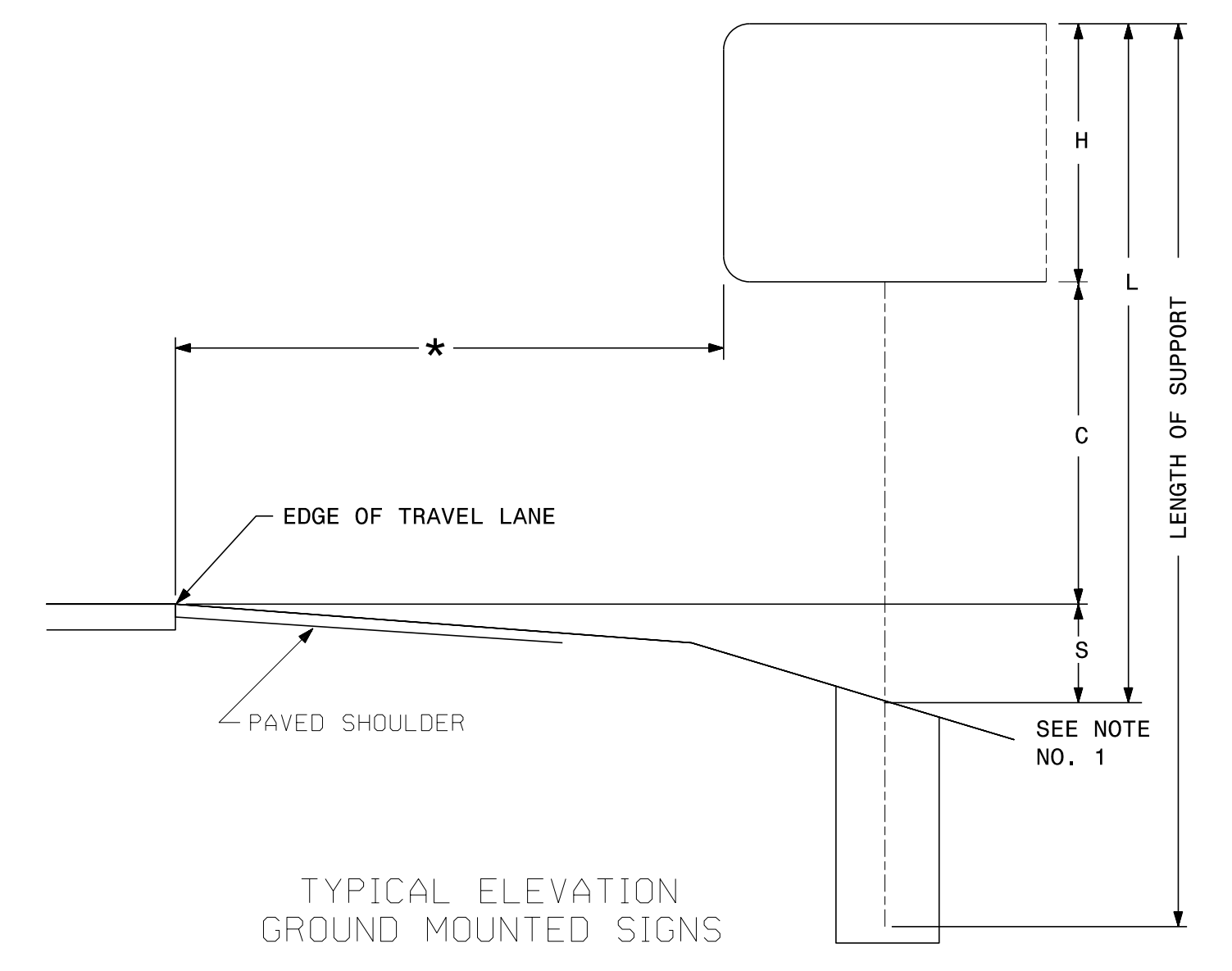

TYPICAL ELEVATION GROUND MOUNTED SIGNS

3/13/2023
 P:\Traffic\Signing\CADD\Signing Layout Plans\C5621_sign_support_chart.dgn
 User:Rkgerinn

**TYPE "A" GROUND MOUNTED
SIGN SUPPORT INFORMATION**



APPROVED: [Signature] DATE: 7/10/2023

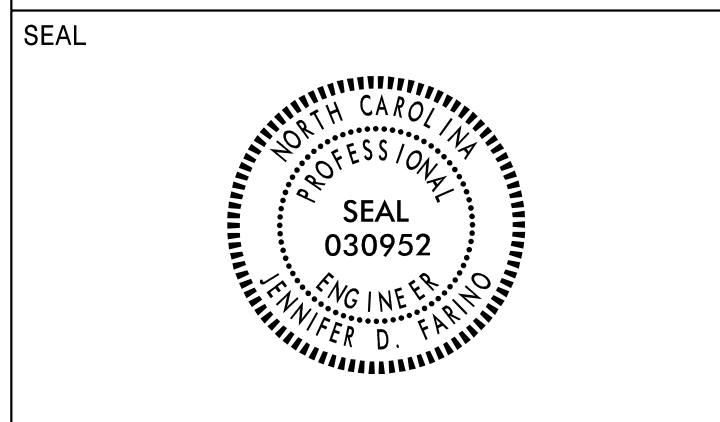

DOCUMENT NOT CONSIDERED FINAL UNLESS ALL SIGNATURES COMPLETED

401 QUANTITY REQ'D 13

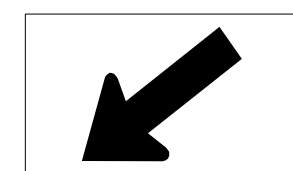

24 X 12
W16-7L

YELLOW/GREEN REFLECTIVE SHEETING

MOUNT BELOW SIGN 403
IN 13 INSTALLATIONS

402 QUANTITY REQ'D 7

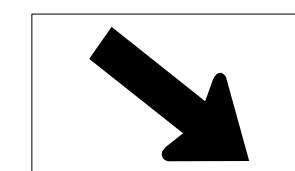

24 X 12
W16-7R

YELLOW/GREEN REFLECTIVE SHEETING

MOUNT BELOW SIGN 403
IN 7 INSTALLATIONS

403 QUANTITY REQ'D 20



36 X 36
W11-2

YELLOW/GREEN REFLECTIVE SHEETING

ONE "U" POST PER SIGN

404 QUANTITY REQ'D 8

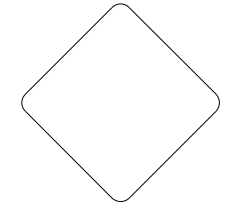

12 X 36
OM1-3

YELLOW/GREEN REFLECTIVE SHEETING

MOUNT BELOW SIGN 406
IN 8 INSTALLATIONS

405 QUANTITY REQ'D 2



36 X 36
R3-7

RIGHT LANE
MUST
TURN RIGHT

ONE "U" POST PER SIGN

406 QUANTITY REQ'D 8

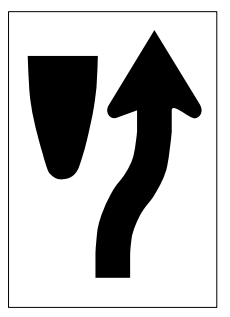

24 X 30
R4-7

ONE "U" POST PER SIGN

407 QUANTITY REQ'D 10

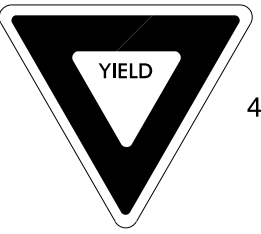

48 X 48 X 48
R1-2

YIELD

ONE "U" POST PER SIGN

408 QUANTITY REQ'D 3

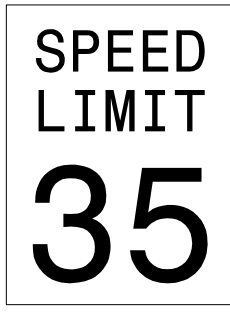

30 X 36
R2-1

SPEED
LIMIT
35

ONE "U" POST PER SIGN

409 QUANTITY REQ'D 2



30 X 36
R2-1

SPEED
LIMIT
25

ONE "U" POST PER SIGN

410 QUANTITY REQ'D 1

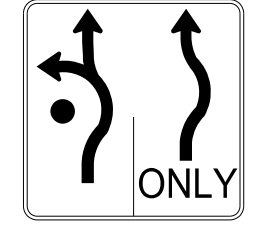

36 X 36
R3-8

ONLY

ONE "U" POST PER SIGN

411 QUANTITY REQ'D 2

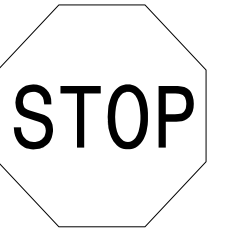

36 X 36
R1-1

STOP

ONE "U" POST PER SIGN

412 QUANTITY REQ'D 2

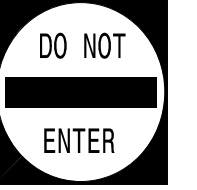

36 X 36
R5-1

DO NOT
ENTER

ONE "U" POST PER SIGN

413 QUANTITY REQ'D 6

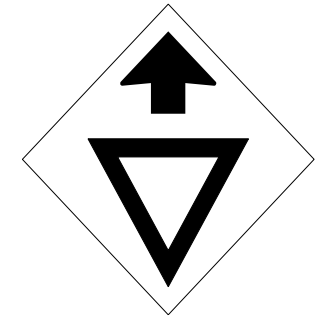

30 X 30
W3-2a

ONE "U" POST PER SIGN

414 QUANTITY REQ'D 1



36 X 36
W14-1

DEAD
END

MOUNT BELOW SIGN 409
IN 1 INSTALLATION

415 QUANTITY REQ'D 5

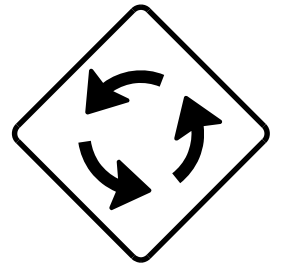

30 X 30
W2-6

ONE "U" POST PER SIGN

416 QUANTITY REQ'D 1

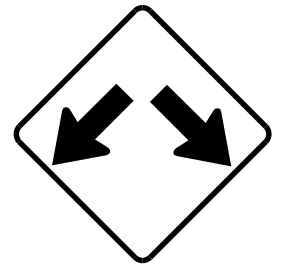

36 X 36
W12-1

ONE "U" POST PER SIGN

417 QUANTITY REQ'D 3

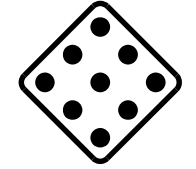

18 X 18
OM4-1

ONE "U" POST PER SIGN

418 QUANTITY REQ'D 12

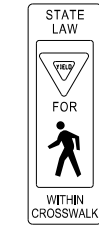

12 X 36
R1-6A

STATE
LANE

MOUNT SIGN 426 BACK TO
BACK IN 6 INSTALLATIONS

419 QUANTITY REQ'D 1



24 X 24
R3-4

ONE "U" POST PER SIGN

420 QUANTITY REQ'D 1

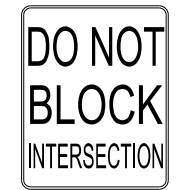

24 X 30
R10-7

DO NOT
BLOCK
INTERSECTION

ONE "U" POST PER SIGN

421 QUANTITY REQ'D 2



12 X 36
R1-6

STATE
LANE

ONE "U" POST PER SIGN

422 QUANTITY REQ'D 1



36 X 36
R3-8

ONLY

ONE "U" POST PER SIGN

423 QUANTITY REQ'D 3

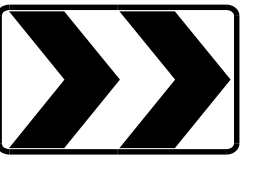

30 X 24
R6-4

ONE "U" POST PER SIGN

424 QUANTITY REQ'D 3

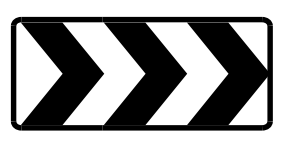

48 X 24
R6-4A

TWO "U" POST PER SIGN

425 QUANTITY REQ'D 1

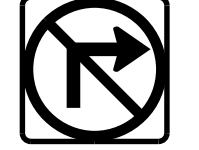

24 X 24
R3-1

ONE "U" POST PER SIGN

426 QUANTITY REQ'D 1

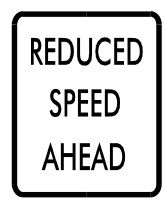

24 X 30
R2-5 A

REDUCED
SPEED
AHEAD

ONE "U" POST PER SIGN

3/13/2023 11:00 AM C:\Users\jrd\OneDrive\Documents\CADD\Signing Layout Plans\C5621_sign_e_sign.dgn

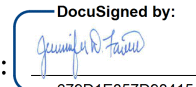

TYPE "E" SIGNS

APPROVED: 
DATE: 7/10/2023

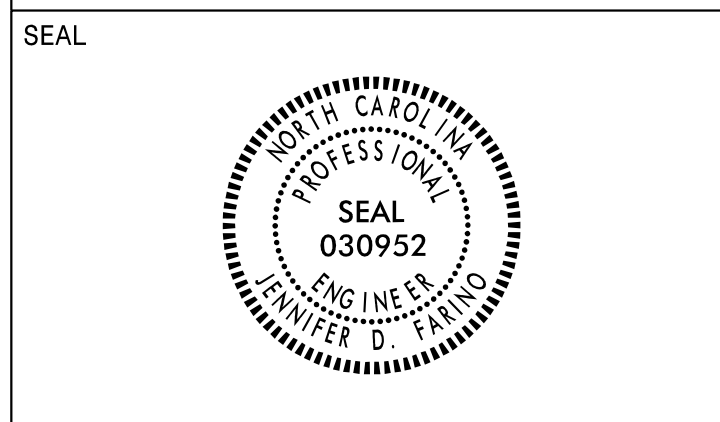

DOCUMENT NOT CONSIDERED FINAL
UNLESS ALL SIGNATURES COMPLETED

501 QUANTITY REQ'D 1

24 X 12 M3-1 NORTH SOUTH 24 X 12 M3-3
 24 X 24 M1-4 21 21 24 X 24 M1-4
 21 X 15 M6-3 ↑ → 21 X 15 M6-1R

TWO "U" POSTS PER SIGN

502 QUANTITY REQ'D 1

21 X 15 M2-1 JCT JCT 21 X 15 M2-1
 24 X 24 M1-1 INTERSTATE 77 21 24 X 24 M1-4
 24 X 24 M1-1 21 24 X 24 M1-4

TWO "U" POSTS PER SIGN

503 QUANTITY REQ'D 1

24 X 12 M4-5 TO NORTH 24 X 12 M3-1
 24 X 24 M1-1 INTERSTATE 77 21 24 X 24 M1-4
 21 X 15 M6-1L ← ← 21 X 15 M6-1L

TWO "U" POSTS PER SIGN

504 QUANTITY REQ'D 1

SOUTH 24 X 12 M3-3
 21 24 X 24 M1-4

ONE "U" POST PER SIGN

505 QUANTITY REQ'D 1

SOUTH 24 X 12 M3-3
 21 24 X 24 M1-4
 → 21 X 15 M6-1R

TWO "U" POSTS PER SIGN

506 QUANTITY REQ'D 1

24 X 12 M4-5 TO 24 X 12 M3-1
 24 X 24 M1-1 INTERSTATE 77
 21 X 15 M6-1R →
 24 X 12 M3-3 SOUTH NORTH 24 X 12 M3-1
 24 X 24 M1-4 21 21 24 X 24 M1-4
 21 X 15 M6-3 ↑ → 21 X 15 M6-1R

TWO "U" POSTS PER SIGN

507 QUANTITY REQ'D 1

SOUTH 24 X 12 M3-3
 21 24 X 24 M1-4
 ↻ 21 X 21 MX-X (302)

ONE "U" POST PER SIGN

508 QUANTITY REQ'D 1

SOUTH 24 X 12 M3-3
 21 24 X 24 M1-4
 ↗ 21 X 15 M6-2

ONE "U" POST PER SIGN

3/13/2023
P:\1\Office\Signing\CADD\Signing Layout Plans\C5621_sign.f sign.dgn
User:Rvdierm



TYPE "F" SIGNS

SIGN NUMBER: 101
 TYPE: A
 QUANTITY: 1
 SIGN WIDTH: 9'-6"
 HEIGHT: 8'-6"
 TOTAL AREA: 80.8 Sq.Ft.
 BORDER TYPE: FLUSH
 RECESS: 0"
 WIDTH: 2"
 RADII: 12"
 NO. Z BARS: 3
 LENGTH: 106.0

SYMBOL	X	Y	WID	HT
M1_1	20.6	51.2	24	24
M1_4	70.5	51.2	24	24
AR_Type A	42.6	6	18.3	28.8

MAT'L: 0.125" (3.2 mm) ALUMINUM

DESIGN BY: NEA
 PROJECT ID: C-5621
 CHECKED BY: JDF
 LOCATION: MECK. CO.
 Mar 07, 2023
 DIV: DIV 10

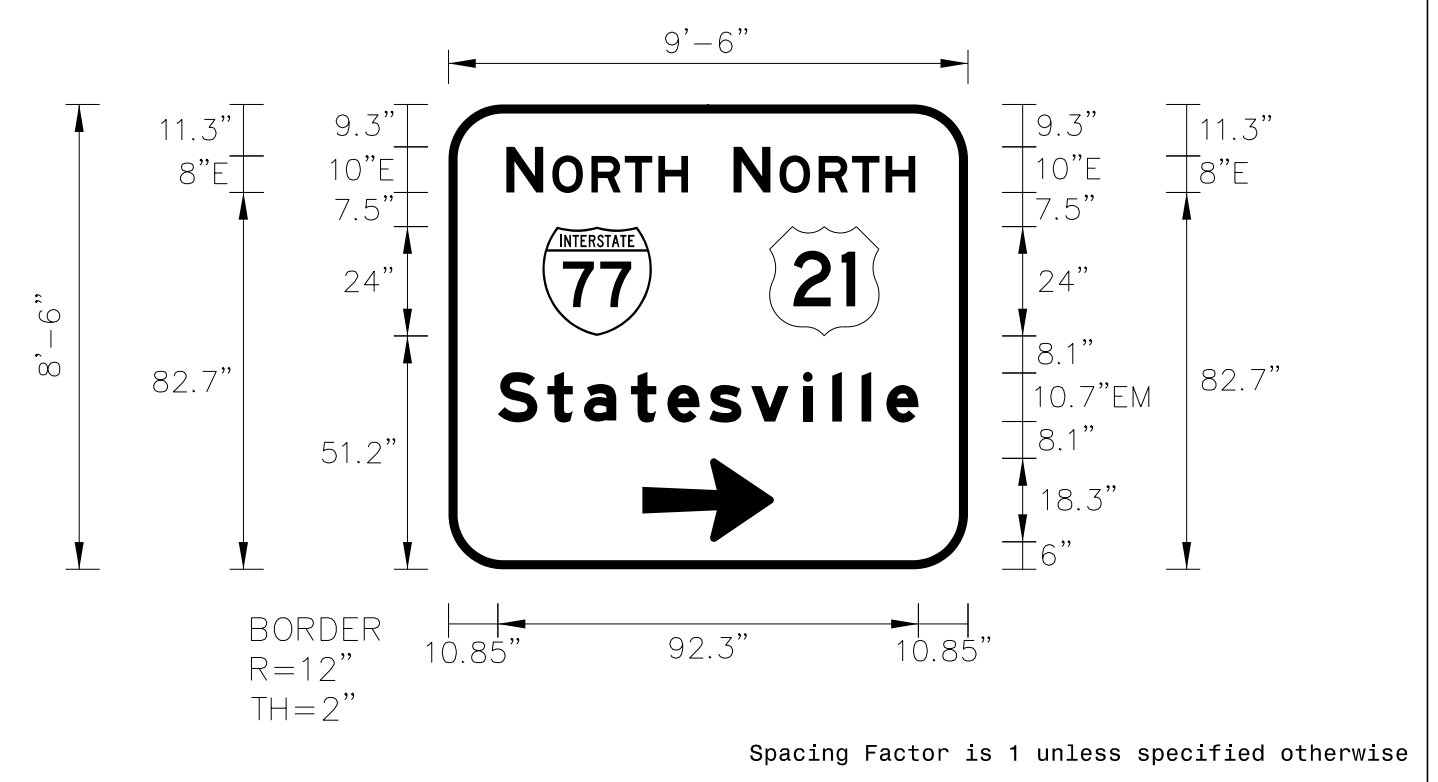

USE NOTES:
 1. Legend and border(except those that are colored black) shall be direct applied Grade C sheeting.
 2. Background shall be Grade C reflective sheeting.
 3. Shields; A, B, and C type arrows shall be on 0.032" (0.8mm) aluminum and demountable

LETTER POSITIONS

Letter spacings are to start of next letter													Series/Size	Text Length
	N	O	R	T	H								E 2000	39.9
12.7	8.1	2	8.6	7.4	7.4	6.5	61.4						E 2000	39.9
	N	O	R	T	H								EM 2000	92.3
62.6	8.1	2	8.6	7.4	7.4	6.5	11.6						E 2000	39.9
	S	t	a	t	e	s	v	i	l	i	e		EM 2000	92.3
10.9	10.9	8	10.3	8	9.2	9.2	11.3	6.4	6.4	5.5	7	10.8		

Spacing Factor is 1 unless specified otherwise

FILENAME: C5621_sign_sign design 101_dsn NORTH CAROLINA D.O.T. SIGN DETAIL

SIGN NUMBER: 102
 TYPE: A
 QUANTITY: 1
 SIGN WIDTH: 10'-6"
 HEIGHT: 13'-6"
 TOTAL AREA: 141.8 Sq.Ft.
 BORDER TYPE: FLUSH
 RECESS: 0"
 WIDTH: 2"
 RADII: 12"
 NO. Z BARS: 4
 LENGTH: 118.0

SYMBOL	X	Y	WID	HT
M1_1	26.6	129.9	24	24
M1_1	25.2	41.9	24	24
M1_4	76.9	41.9	24	24

MAT'L: 0.125" (3.2 mm) ALUMINUM

DESIGN BY: NEA
 PROJECT ID: C-5621
 CHECKED BY: JDF
 LOCATION: MECK. CO.
 Mar 08, 2023
 DIV: DIV 10

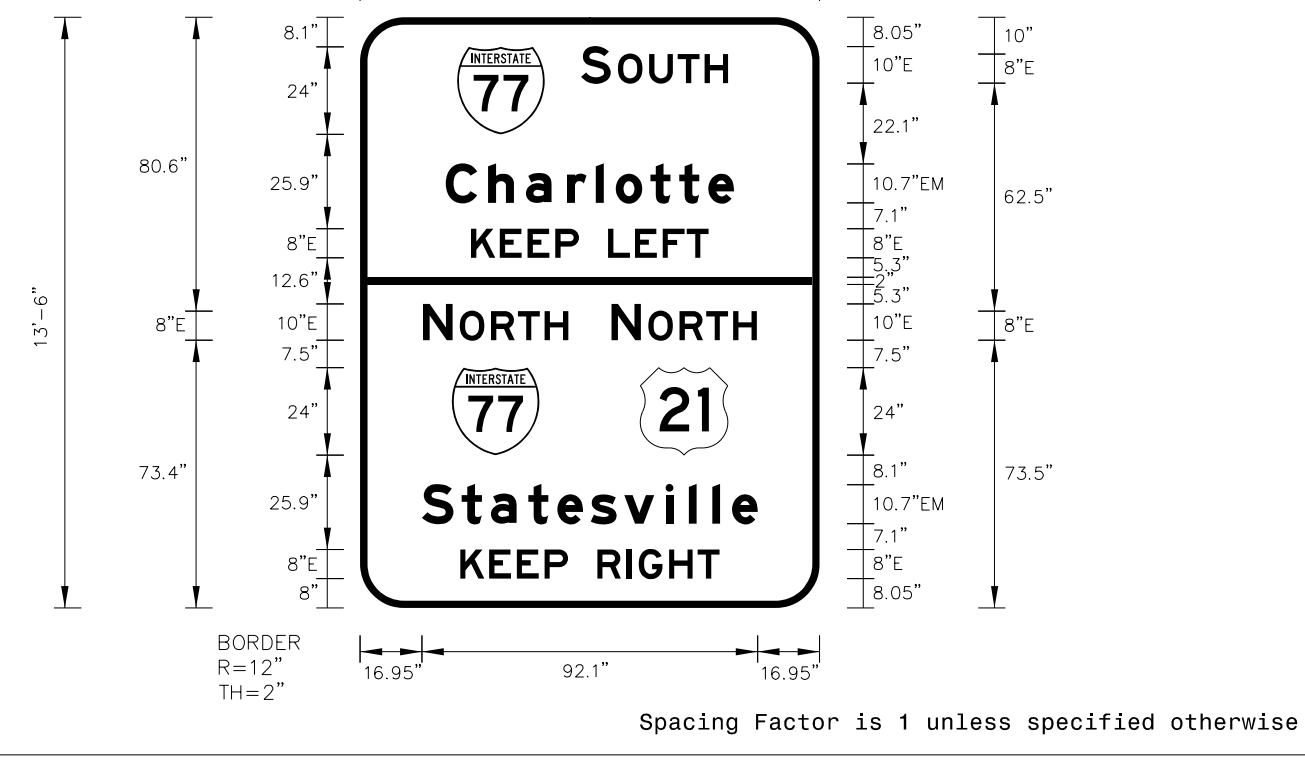

USE NOTES:
 1. Legend and border(except those that are colored black) shall be direct applied Grade C sheeting.
 2. Background shall be Grade C reflective sheeting.
 3. Shields; A, B, and C type arrows shall be on 0.032" (0.8mm) aluminum and demountable.

LETTER POSITIONS

Letter spacings are to start of next letter													Series/Size	Text Length
	S	O	U	T	H								E 2000	40.3
60.6	8.1	2	8.6	7.8	7.4	6.5	25.1						EM 2000	79.1
	C	h	a	r	l	o	t	t	e				E 2000	65.2
23.5	11.6	10.3	11.3	7.9	5.4	9.5	7.9	8	7	23.5			E 2000	65.2
	K	E	E	P	L	E	F	T					E 2000	71.1
30.4	7.9	7.6	7.6	6.5	8	7.4	7.6	6.6	6	30.4			E 2000	39.9
	N	O	R	T	H								E 2000	39.9
17.2	8.1	2	8.6	7.4	7.4	6.5	68.9						E 2000	92.1
	N	O	R	T	H								E 2000	92.1
68.9	8.1	2	8.6	7.4	7.4	6.5	17.2						EM 2000	92.1
	S	t	a	t	e	s	v	i	l	i	e		E 2000	71.1
17	10.9	8	10.2	8	9.2	9.2	11.3	6.4	6.4	5.4	7	17		
	K	E	E	P	R	I	G	H	T				E 2000	71.1
27.4	7.9	7.6	7.6	6.5	8	8.1	3.3	8.3	7.8	6	27.4			

Spacing Factor is 1 unless specified otherwise

FILENAME: C5621_sign_sign design 102_dsn NORTH CAROLINA D.O.T. SIGN DETAIL

APPROVED: [Signature]
 DATE: 7/10/2023



DOCUMENT NOT CONSIDERED FINAL UNLESS ALL SIGNATURES COMPLETED

SIGN NUMBER: 103
 TYPE: A
 QUANTITY: 1
 SIGN WIDTH: 9'-0"
 HEIGHT: 12'-6"
 TOTAL AREA: 112.5 Sq.Ft.
 BORDER TYPE: FLUSH
 RECESS: 0"
 WIDTH: 2"
 RADII: 12"
 NO. Z BARS: 4
 LENGTH: 100.0

SYMBOL	X	Y	WID	HT
M1_1	16.1	86.7	24	24
M1_4	67.9	86.7	24	24
M1_1	16.1	21	24	24

MAT'L: 0.125" (3.2 mm) ALUMINUM

DESIGN BY: NEA
 PROJECT ID: C-5621
 CHECKED BY: JDF
 LOCATION: MECK. CO.
 Mar 08, 2023
 DIV: DIV 10

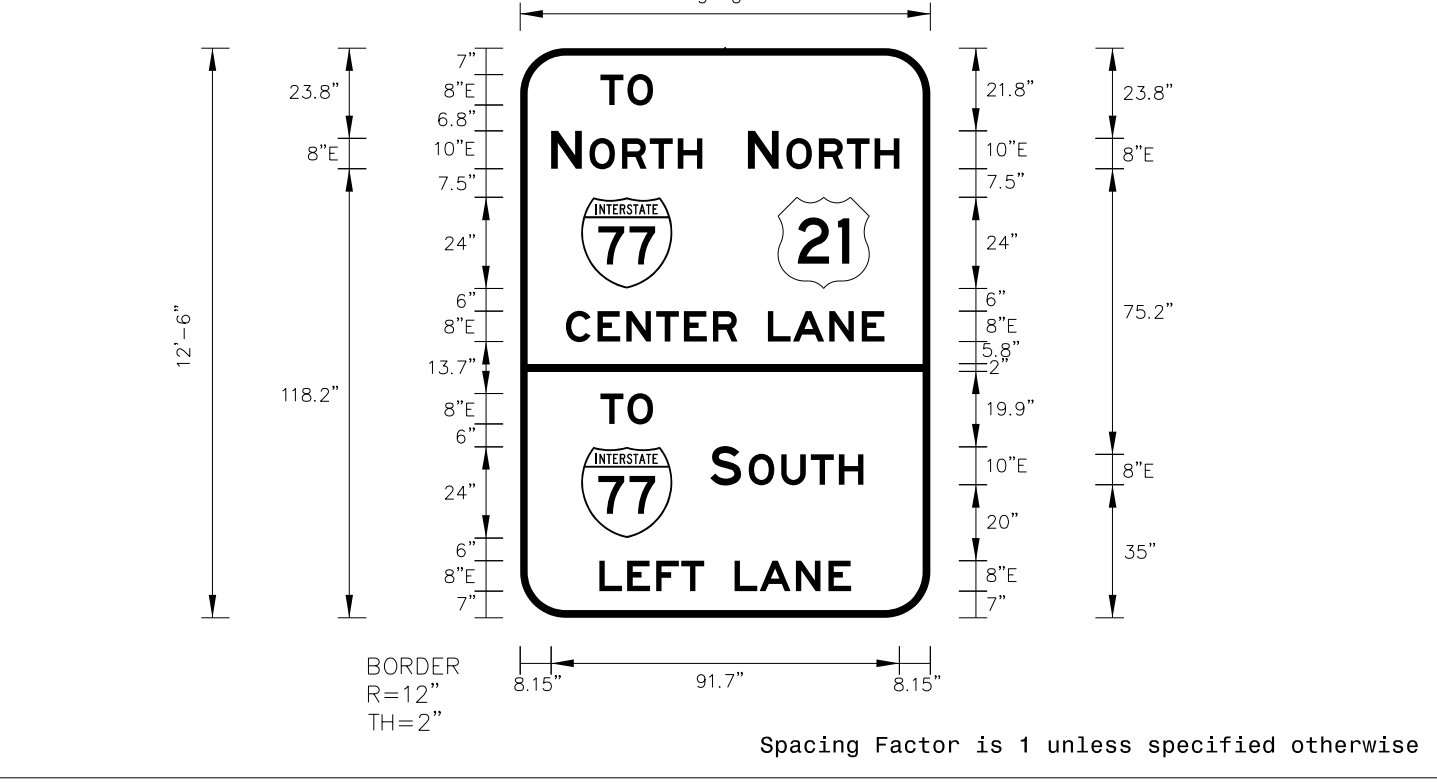

USE NOTES:
 1. Legend and border(except those that are colored black) shall be direct applied Grade C sheeting.
 2. Background shall be Grade C reflective sheeting.
 3. Shields; A, B, and C type arrows shall be on 0.032" (0.8mm) aluminum and demountable.

LETTER POSITIONS

Letter spacings are to start of next letter													Series/Size	Text Length
	T	O											E 2000	13.8
21.2	7.1	6.7	7.3										E 2000	39.9
	N	O	R	T	H								E 2000	39.9
8.2	8.1	2	8.6	7.4	7.4	6.5	60						E 2000	39.9
	N	O	R	T	H								E 2000	83.9
60	8.1	2	8.6	7.4	7.4	6.5	8.1						E 2000	83.9
	C	E	N	T	E	R	L	A	N	E			E 2000	66.3
12	8.3	7.6	7.8	7.4	7.6	6.5	8	6.6	9.5	8.6	6	12		
	T	O											E 2000	13.8
21.2	7.1	6.7	7.3										E 2000	40.3
	S	O	U	T	H								E 2000	40.3
50.1	8.1	2	8.6	7.8	7.4	6.5	17.6						E 2000	66.3
	L	E	F	T	L	A	N	E					E 2000	66.3
20.8	7.4	7.6	6.6	6	8	6.6	9.5	8.6	6	20.8				

Spacing Factor is 1 unless specified otherwise

FILENAME: C5621_sign_sign design 103_dsn NORTH CAROLINA D.O.T. SIGN DETAIL

3/13/2023 10:11:00 AM C:\Users\neadm\OneDrive\Documents\CADD\Signing Layout Ploms\C5621_sign_sign design 101.dgn



SIGN DESIGNS

APPROVED:

DATE: 7/10/2023

DocuSigned by:
670D1E857D68415

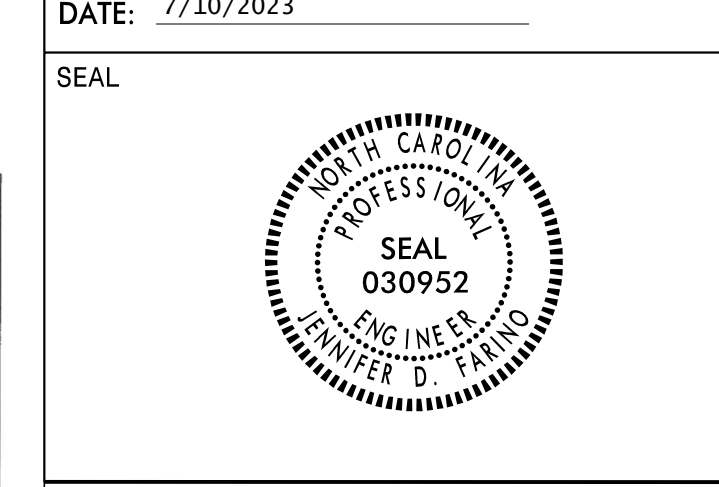

DOCUMENT NOT CONSIDERED FINAL
UNLESS ALL SIGNATURES COMPLETED

SIGN NUMBER: 301 BACKG COLOR: Color 190 DESIGN BY: NEA CHECKED BY: JDF Mar 08, 2023
TYPE: D COPY COLOR: Color 232 PROJECT ID: C-5621 LOCATION: MECK. CO. DIV: DIV 10
QUANTITY: 1

SIGN WIDTH: 6'-0"
HEIGHT: 2'-0"
TOTAL AREA: 12.0 Sq.Ft.
BORDER TYPE: FLUSH
RECESS: 0"
WIDTH: 1"
RADII: 3"
NO. Z BARS:
LENGTH:

SYMBOL	X	Y	WID	HT
AR_Type D	7	7.5	6	9

MAT'L: 0.063" (1.6 mm) ALUMINUM

USE NOTES:
1. Legend and border(except those that are colored black) shall be direct applied Grade C sheeting.
2. Background shall be Grade C reflective sheeting.
3. Shields; A, B, and C type arrows shall be on 0.032" (0.8mm) aluminum and demountable.

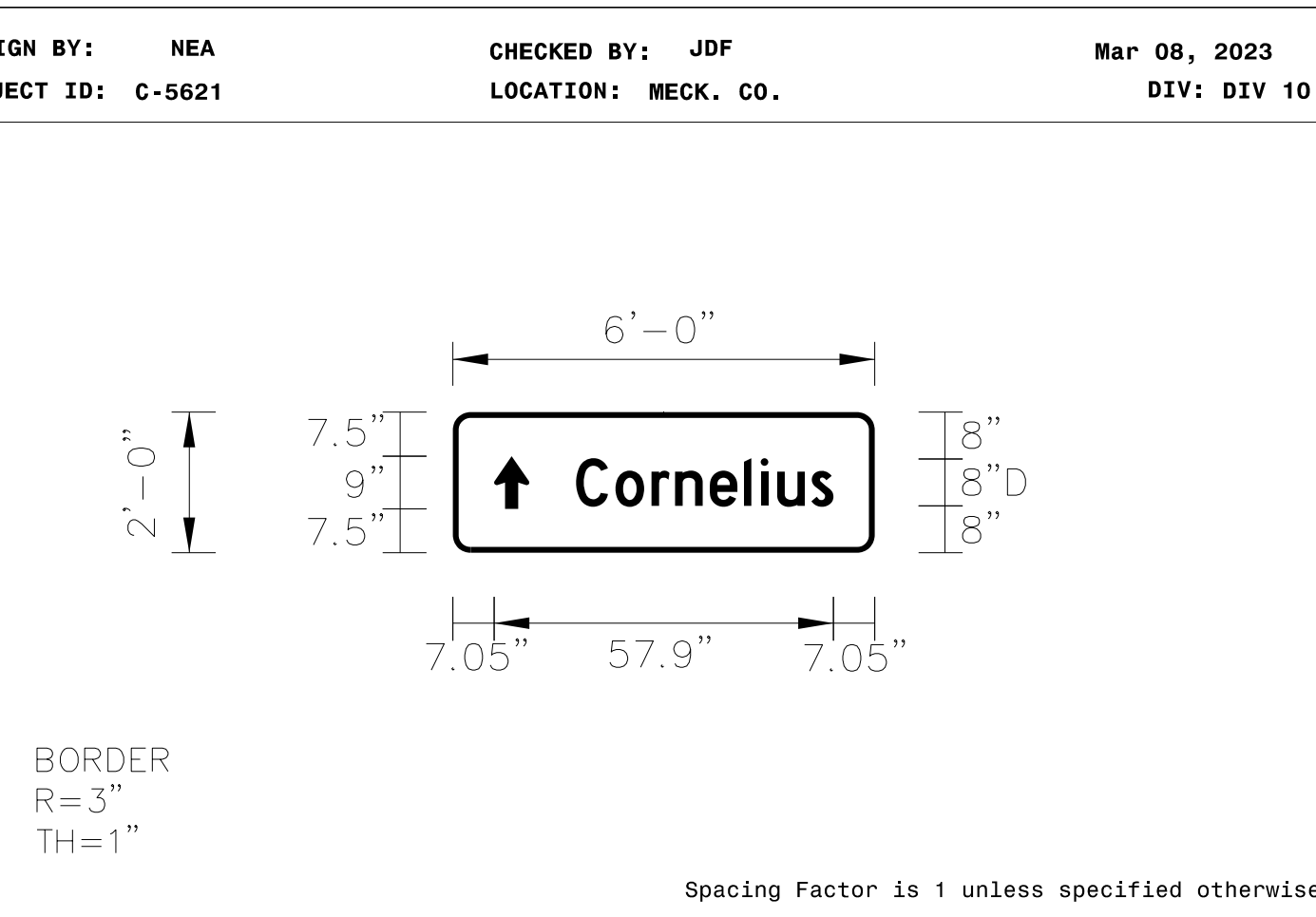

LETTER POSITIONS

Letter spacings are to start of next letter												Series/Size
	C	o	r	n	e	i	i	u	s			Text Length
	21	6.7	6.2	4	5.9	5.8	2.9	2.8	5.8	3.8	7	D 2000
												43.9

FILENAME: C5621_sign_sign design 301_dsn NORTH CAROLINA D.O.T. SIGN DETAIL

SIGN NUMR: 302 BACKG. COLOR: White DESIGN BY: CHK BY: STD #: N. C. DEPARTMENT OF TRANSPORTATION
TYPE: F Ground COPY COLOR: Black PROJECT ID: DIV: DATE: DIVISION OF HIGHWAYS
QUANTITY: 1 TRANSPORTATION MOBILITY & SAFETY
SIGN WIDTH: 1'-9" SIGNING & DELINEATION UNIT

SIGN WIDTH: 1'-9"
HEIGHT: 1'-9"
TOTAL AREA: 3.1 Sq.Ft.
MAT'L: 0.063" ALUMINUM
BORDER TYPE: RECESSED
RECESS: 0.38"
WIDTH: 0.63"
RADII: 1.5"
NO. Z BARS:
LENGTH:

SYMBOL	X	Y	WID	HT
u arrow	3.7	3.5	12.7	13.9

NOTES:
1. Legend and border shall be direct applied Non-reflective sheeting.
2. Background shall be Grade C reflective sheeting.

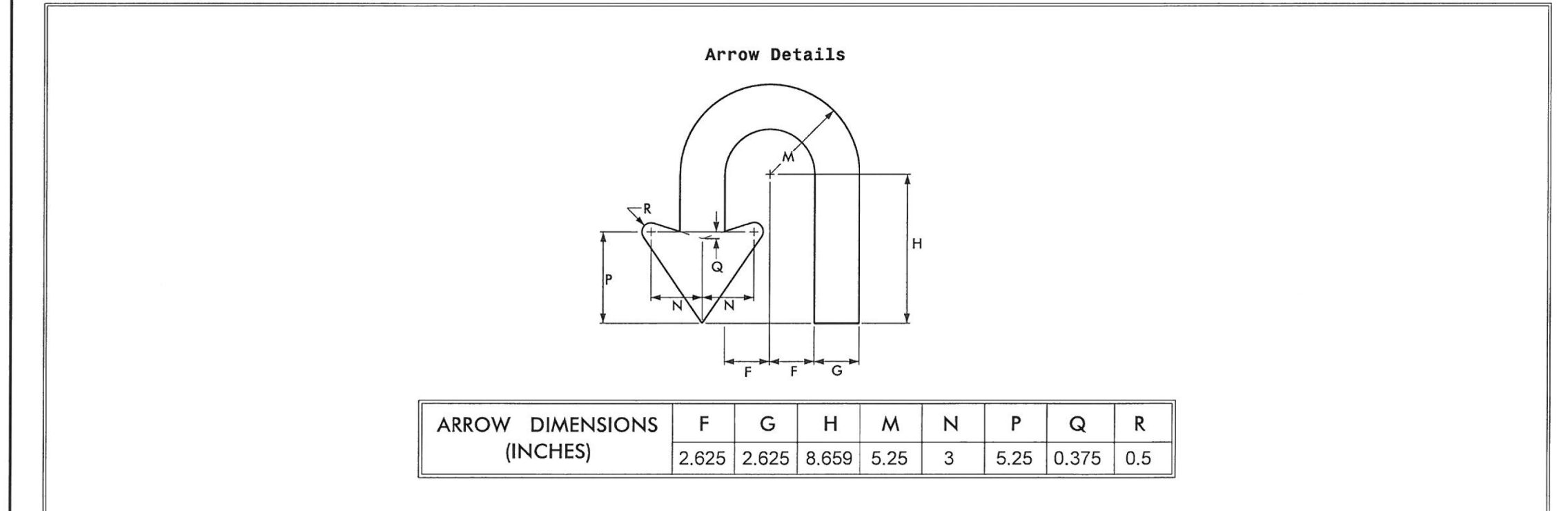
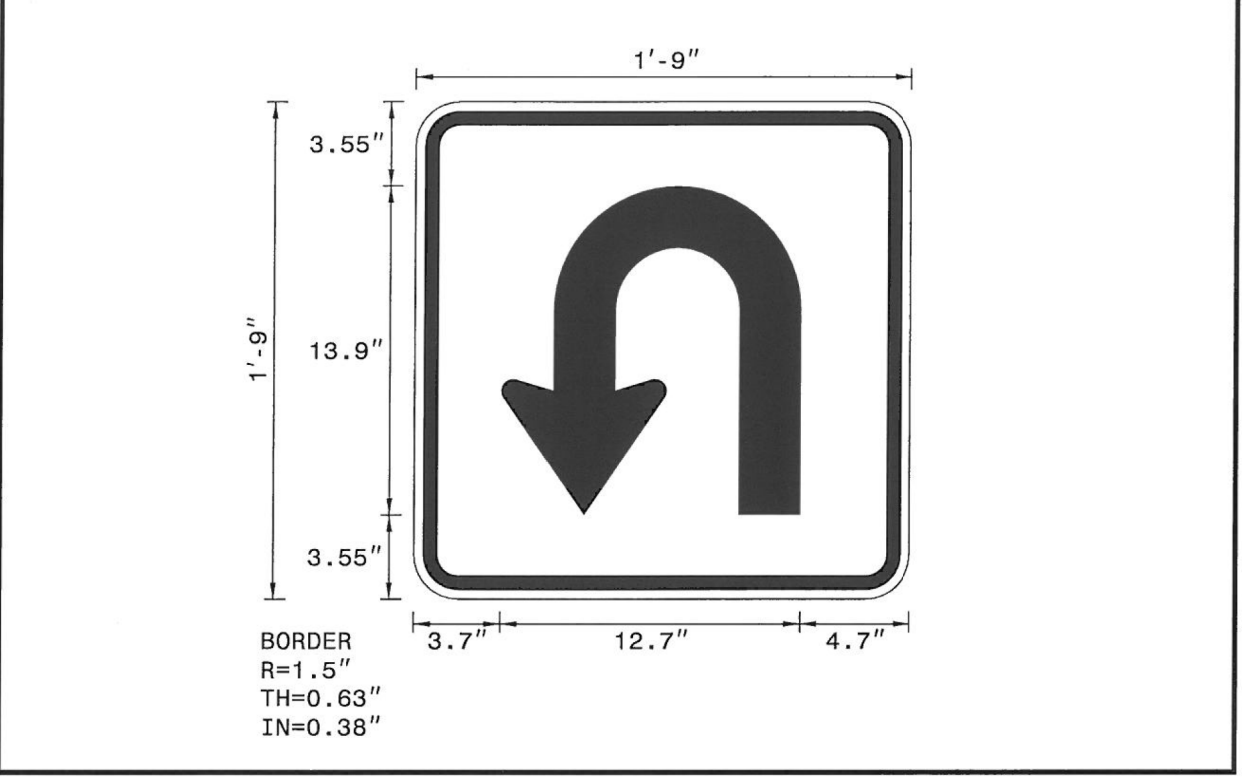

Spacing Factor is 1 unless specified otherwise
FILENAME: 05ENG

3/13/2023
R:\TrafFic\Signing\CADD\Signng Layout Plans\C5621_sign_sign design 301.dgn
User:Rvdgerm



SIGN DESIGNS

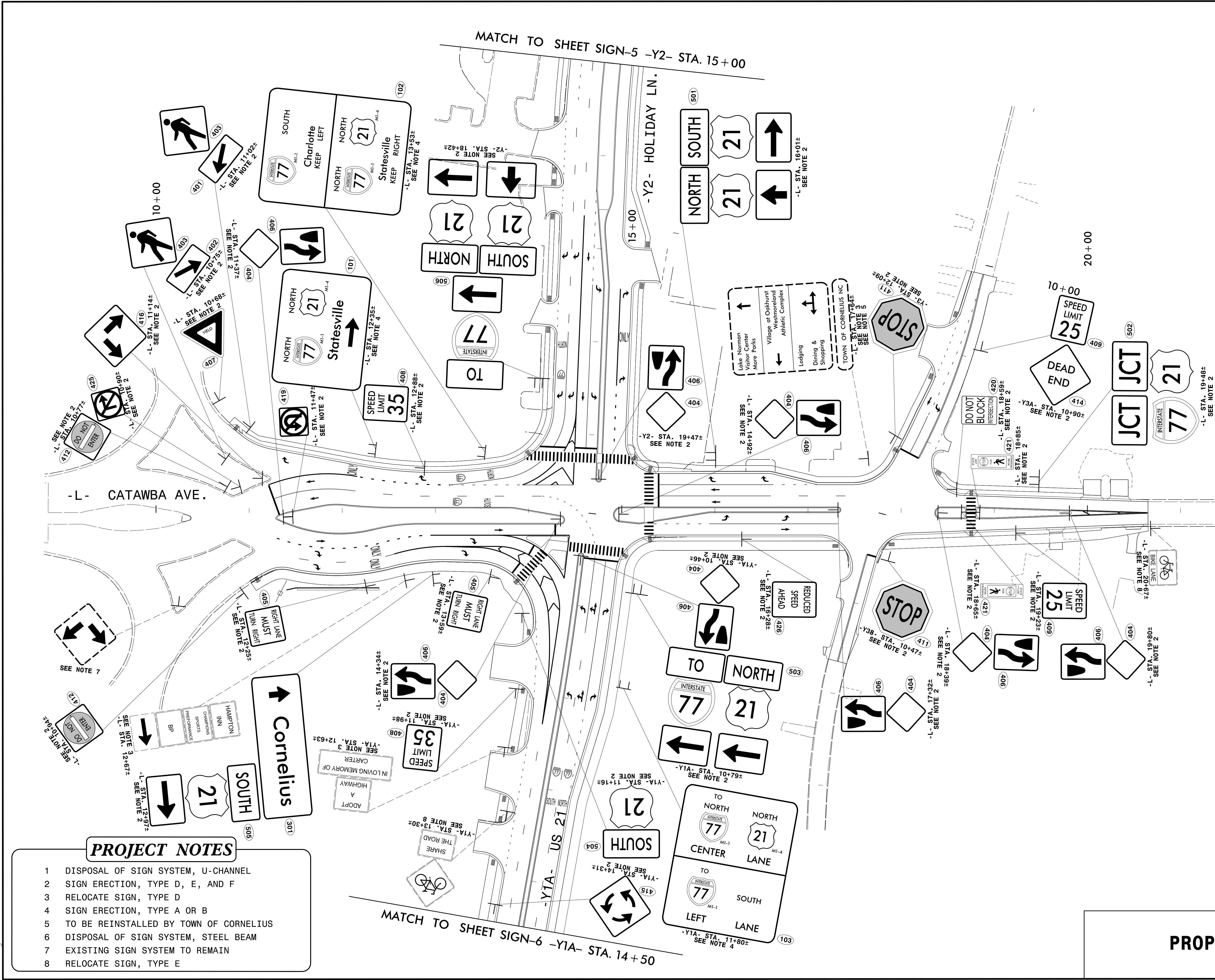
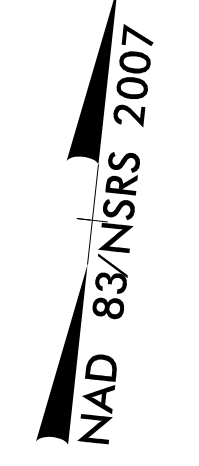

PROJECT NOTES

- DISPOSAL OF SIGN SYSTEM, U-CHANNEL
- SIGN ERECTION, TYPE D, E, AND F
- RELOCATE SIGN, TYPE D
- SIGN ERECTION, TYPE A OR B
- TO BE REINSTALLED BY TOWN OF CORNELIUS
- DISPOSAL OF SIGN SYSTEM, STEEL BEAM
- EXISTING SIGN SYSTEM TO REMAIN
- RELOCATE SIGN, TYPE E

PROPOSED SIGNS

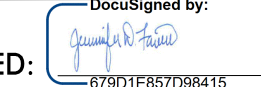
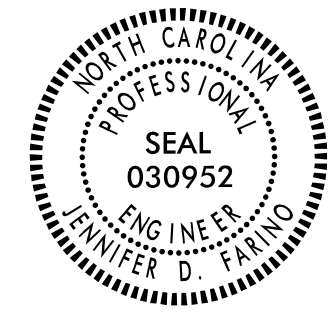

3/13/2023
 P:\Traffic\Signing\CADD\Signing Layout Plans\C5621\sign_prop.dtl_01.dgn
 User: hvdiermnn

TIP NO. C-5621	SHEET NO. SIGN-5
APPROVED: 	
DATE: 7/10/2023	
SEAL 	
DOCUMENT NOT CONSIDERED FINAL UNLESS ALL SIGNATURES COMPLETED	

NAD 83/NSRS 2007



* NOTE: SEE SIGNAL PLANS SHEET Sig-7.0

PROJECT NOTES

- 1 DISPOSAL OF SIGN SYSTEM, U-CHANNEL
- 2 SIGN ERECTION, TYPE D, E, AND F
- 3 RELOCATE SIGN, TYPE D
- 4 SIGN ERECTION, TYPE A OR B
- 5 TO BE REINSTALLED BY TOWN OF CORNELIUS
- 6 DISPOSAL OF SIGN SYSTEM, STEEL BEAM
- 7 EXISTING SIGN SYSTEM TO REMAIN
- 8 RELOCATE SIGN, TYPE E

PROPOSED SIGNS



3/14/2023
R:\Traffic\CADD\Signing Layout Plans\C5621-sign-prop-dtl.02.dgn
User:dvger.rln

TIP NO. C-5621	SHEET NO. SIGN-6
APPROVED: [Signature] 6701E85D08415	
DATE: 7/10/2023	
SEAL 	
DOCUMENT NOT CONSIDERED FINAL UNLESS ALL SIGNATURES COMPLETED	

NAD 83 NSRS 2007

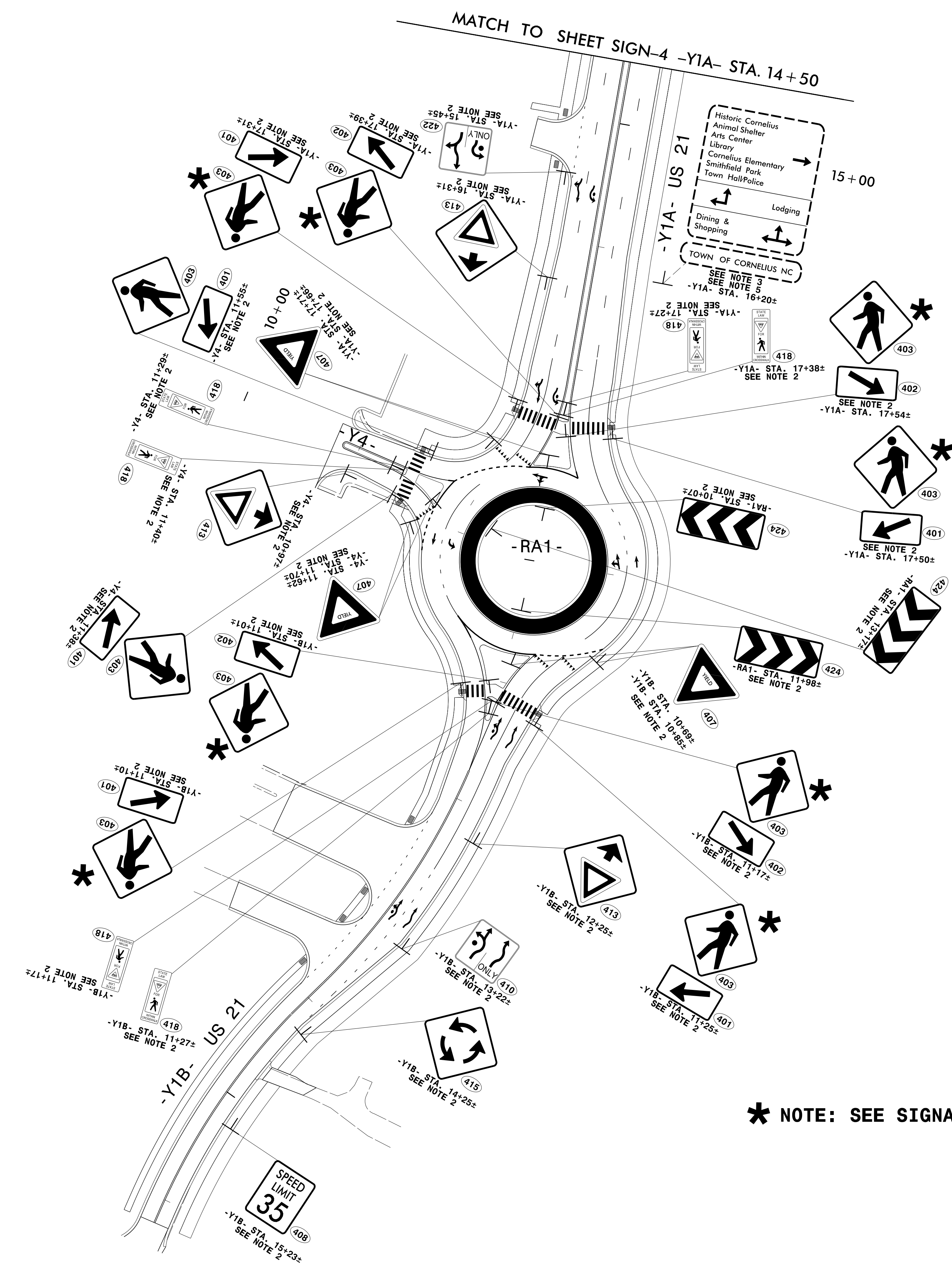



* NOTE: SEE SIGNAL PLANS SHEET Sig-8.0

- PROJECT NOTES**
- DISPOSAL OF SIGN SYSTEM, U-CHANNEL
 - SIGN ERECTION, TYPE D, E, AND F
 - RELOCATE SIGN, TYPE D
 - SIGN ERECTION, TYPE A OR B
 - TO BE REINSTALLED BY TOWN OF CORNELIUS
 - DISPOSAL OF SIGN SYSTEM, STEEL BEAM
 - EXISTING SIGN SYSTEM TO REMAIN
 - RELOCATE SIGN, TYPE E

PROPOSED SIGNS

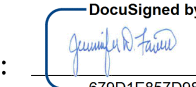

3/13/2023
 P:\Traffic\Signing\CADD\Signing Layout Plans\C5621-sign_prop.dtl.03.dgn
 User:Rvdierman

TIP NO. C-5621	SHEET NO. SIGN-7
APPROVED:  7/10/2023	
DATE: 7/10/2023	
SEAL 	
DOCUMENT NOT CONSIDERED FINAL UNLESS ALL SIGNATURES COMPLETED	

NAD 83/NSRS 2007

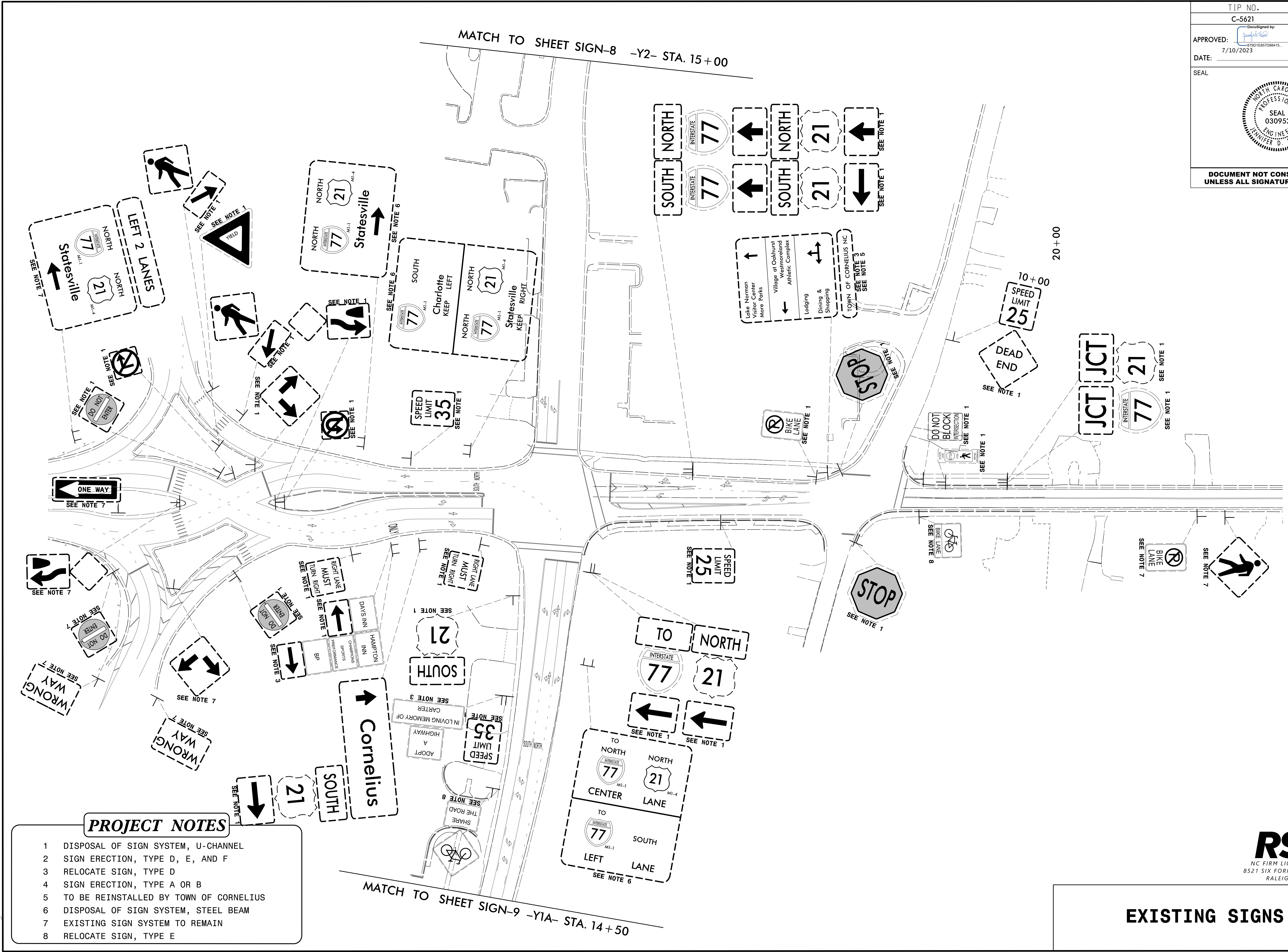

PROJECT NOTES

- DISPOSAL OF SIGN SYSTEM, U-CHANNEL
- SIGN ERECTION, TYPE D, E, AND F
- RELOCATE SIGN, TYPE D
- SIGN ERECTION, TYPE A OR B
- TO BE REINSTALLED BY TOWN OF CORNELIUS
- DISPOSAL OF SIGN SYSTEM, STEEL BEAM
- EXISTING SIGN SYSTEM TO REMAIN
- RELOCATE SIGN, TYPE E

3/13/2023
 P:\Traffic\Signing\CADD\Signing Layout Plans\C5621-sign-exist-dt_01.dgn
 User:Rogier.mn

EXISTING SIGNS

RS&H
 NC FIRM LICENSE No: F-0493
 8521 SIX FORKS ROAD, SUITE 400
 RALEIGH, NC 27615

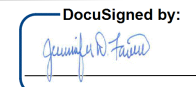
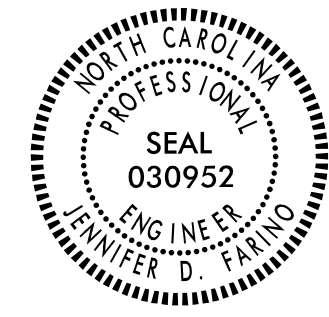
TIP NO. C-5621	SHEET NO. SIGN-8
APPROVED:  87801E857D98415...	
DATE: 7/10/2023	
SEAL 	
DOCUMENT NOT CONSIDERED FINAL UNLESS ALL SIGNATURES COMPLETED	

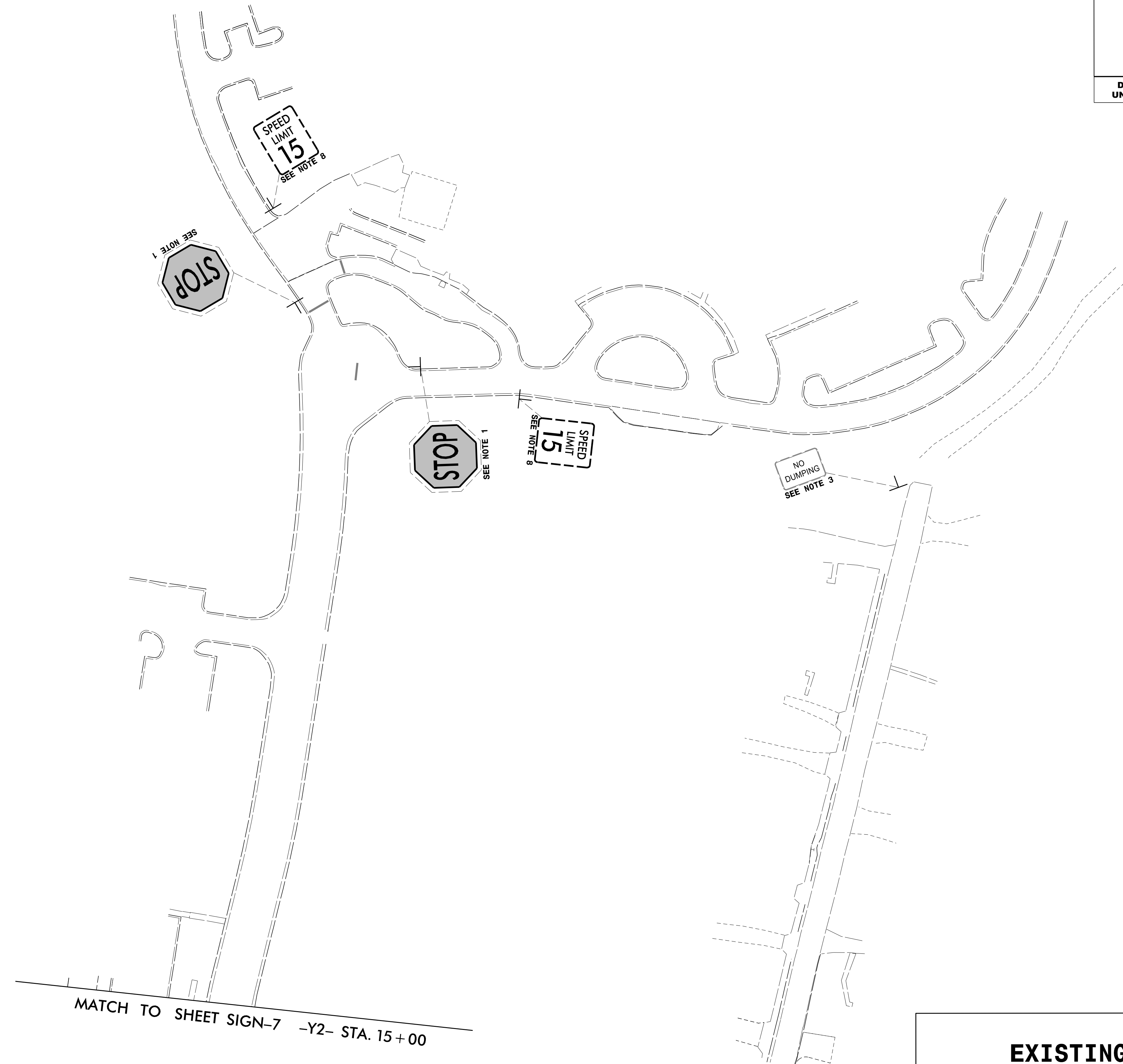

NAD 83/NSRS 2007



PROJECT NOTES

- 1 DISPOSAL OF SIGN SYSTEM, U-CHANNEL
- 2 SIGN ERECTION, TYPE D, E, AND F
- 3 RELOCATE SIGN, TYPE D
- 4 SIGN ERECTION, TYPE A OR B
- 5 TO BE REINSTALLED BY TOWN OF CORNELIUS
- 6 DISPOSAL OF SIGN SYSTEM, STEEL BEAM
- 7 EXISTING SIGN SYSTEM TO REMAIN
- 8 RELOCATE SIGN, TYPE E

3/13/2023
 R:\Tr\Office\CADD\Signing Layout Plans\C5621_sign_exist_dtl_02.dgn
 User: fvgier.rn



EXISTING SIGNS



**DOCUMENT NOT CONSIDERED FINAL
UNLESS ALL SIGNATURES COMPLETED**

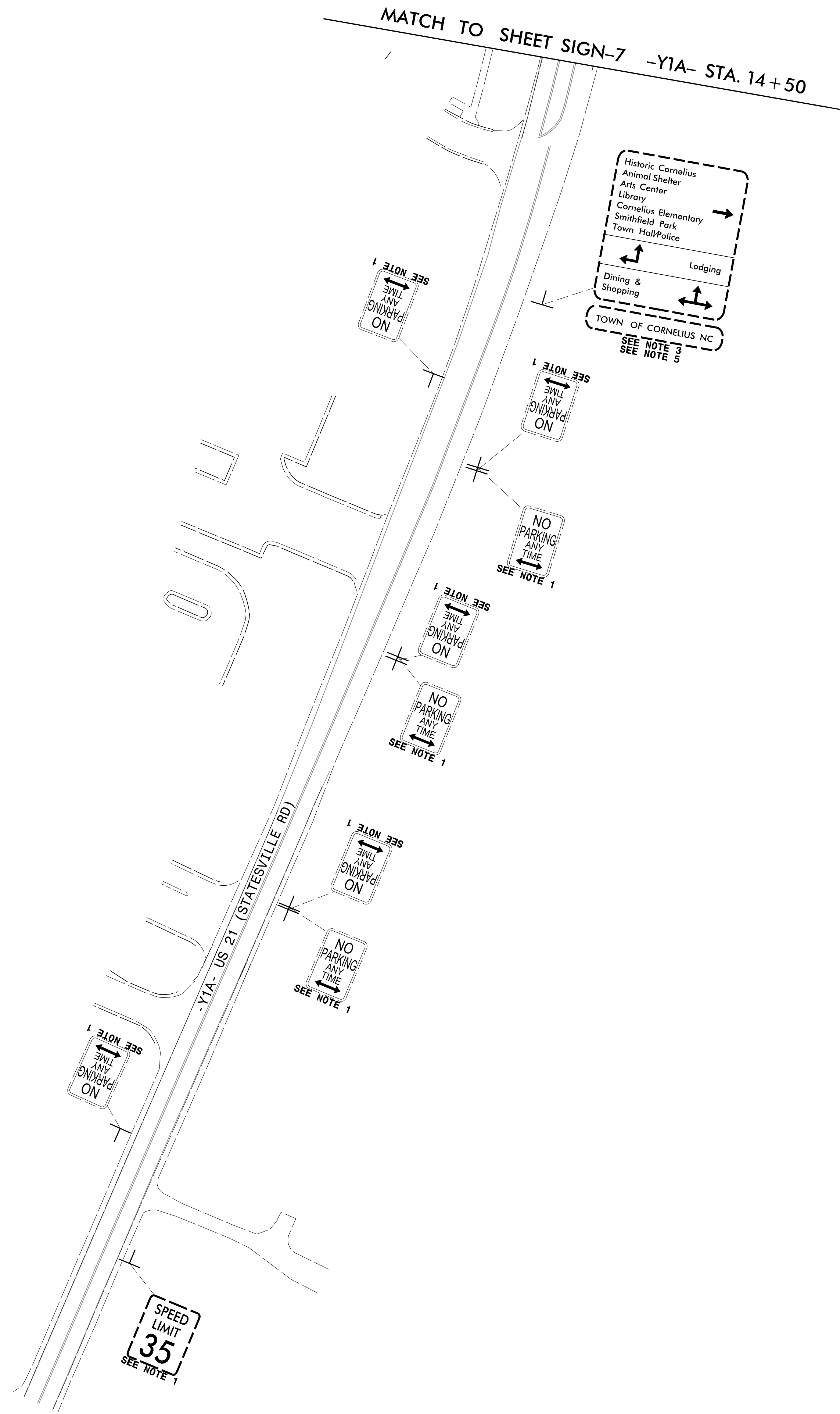

PROJECT NOTES

- 1 DISPOSAL OF SIGN SYSTEM, U-CHANNEL
- 2 SIGN ERECTION, TYPE D, E, AND F
- 3 RELOCATE SIGN, TYPE D
- 4 SIGN ERECTION, TYPE A OR B
- 5 TO BE REINSTALLED BY TOWN OF CORNELIUS
- 6 DISPOSAL OF SIGN SYSTEM, STEEL BEAM
- 7 EXISTING SIGN SYSTEM TO REMAIN
- 8 RELOCATE SIGN, TYPE E

3/13/2023
R:\Traffic\Signing\CADD\Signing Layout Plans\C5621_sign_exist_dtl_03.dgn
User:fvgerinn



EXISTING SIGNS