

Note:  
 1. Opening in pole base plate shall be equal to pole base inside diameter minus 3 1/2" but shall not be less than 8 1/2".

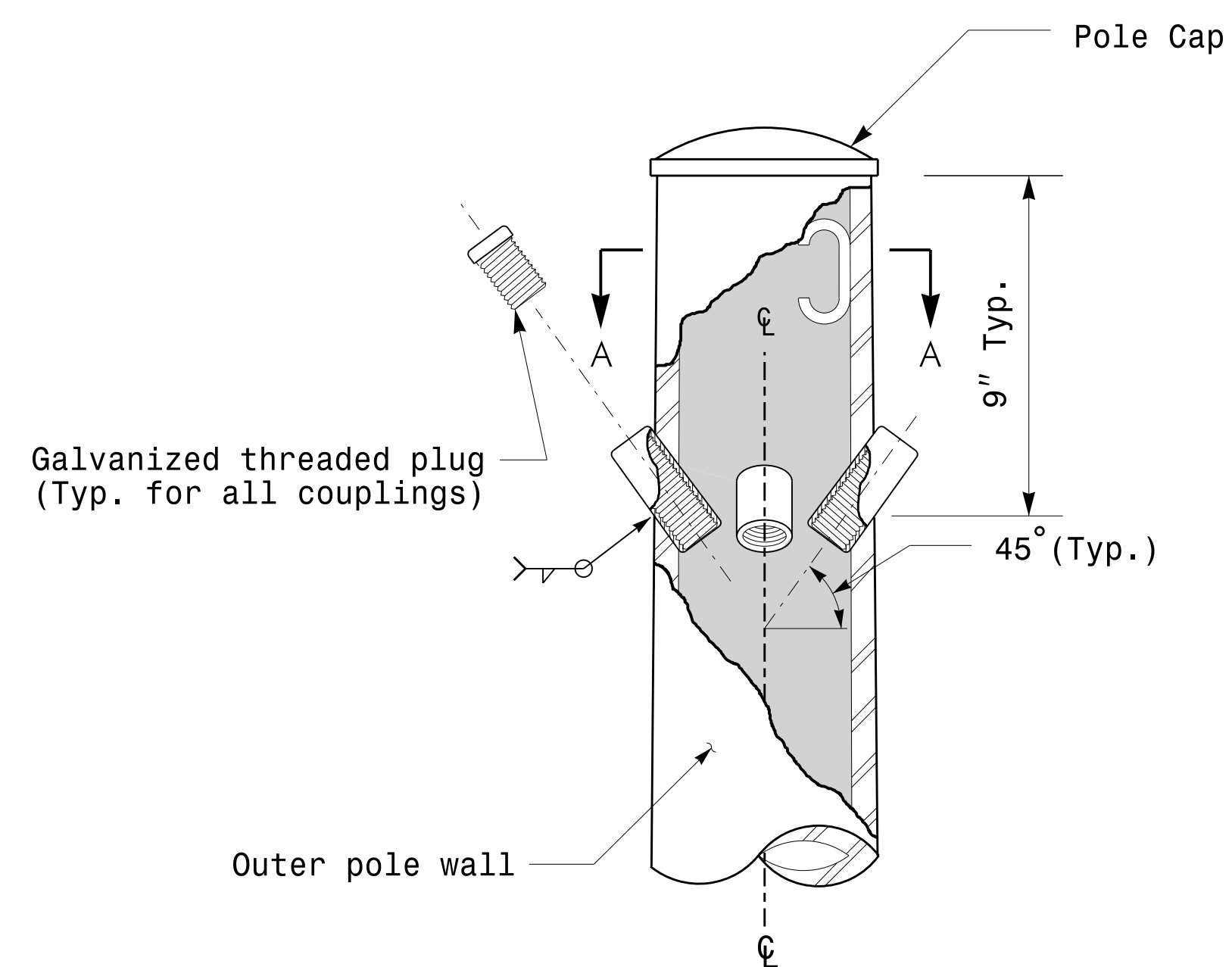

Cable Entrances at Top of Pole

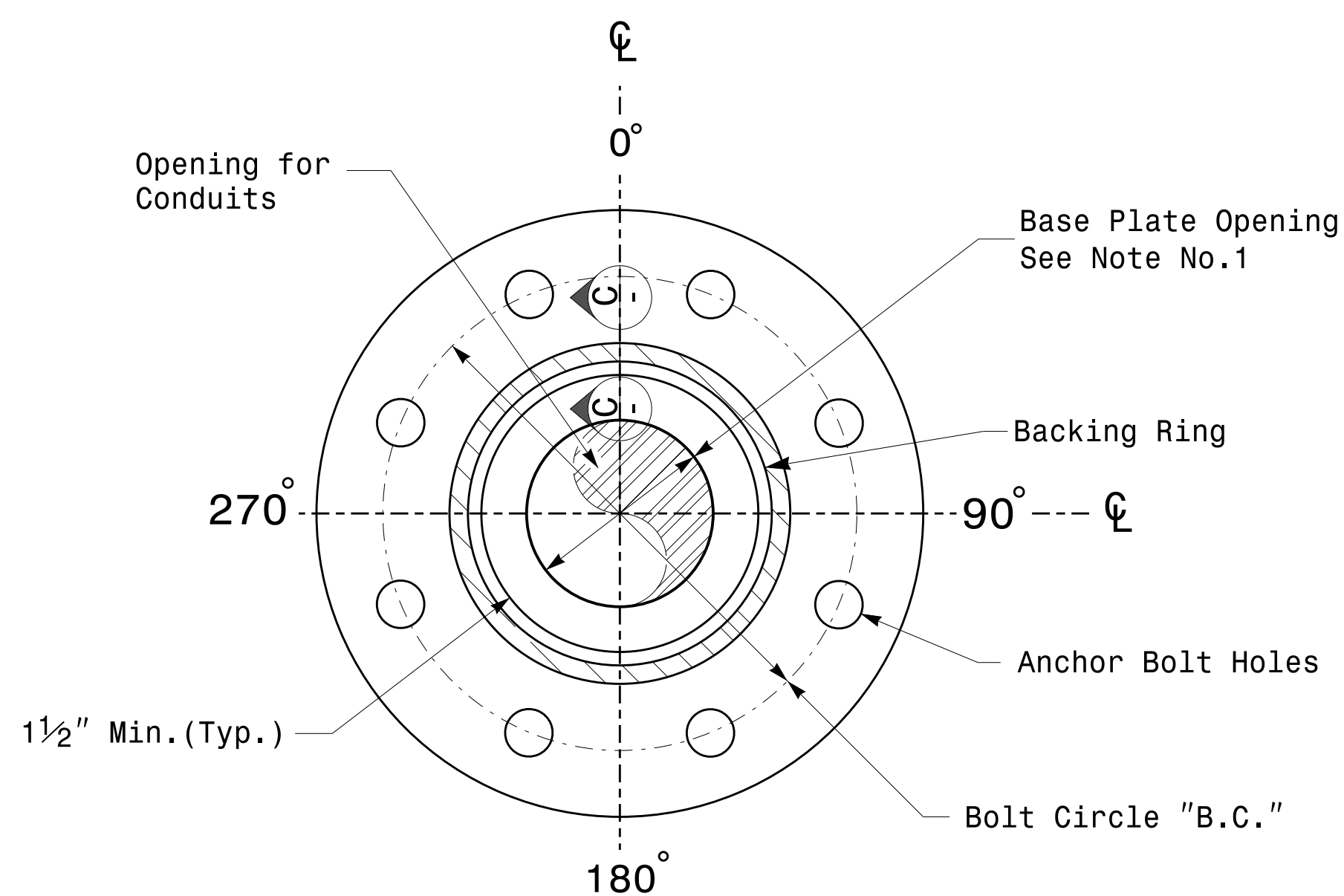

Section B-B Pole Base Plate Details (8 and 12 Bolt Pattern)

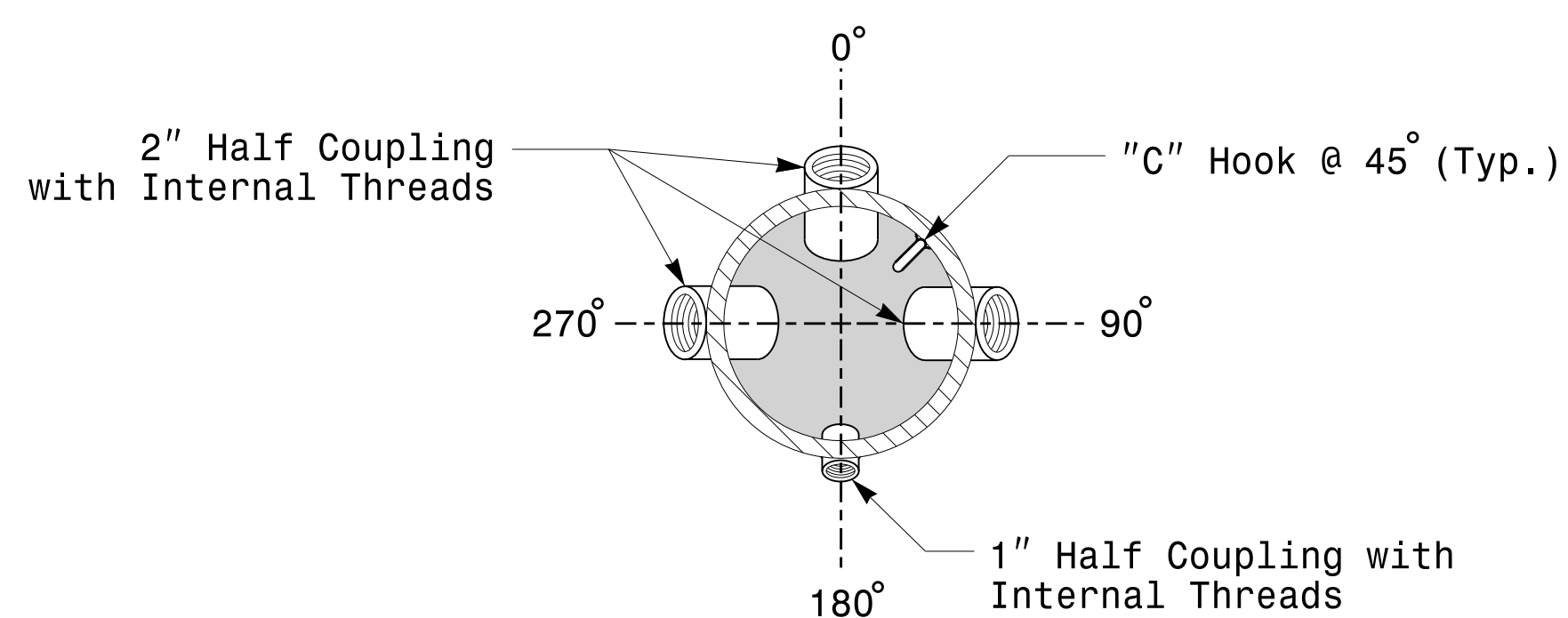

Section A-A Radial Orientation for Factory Installed Accessories at Top of Pole

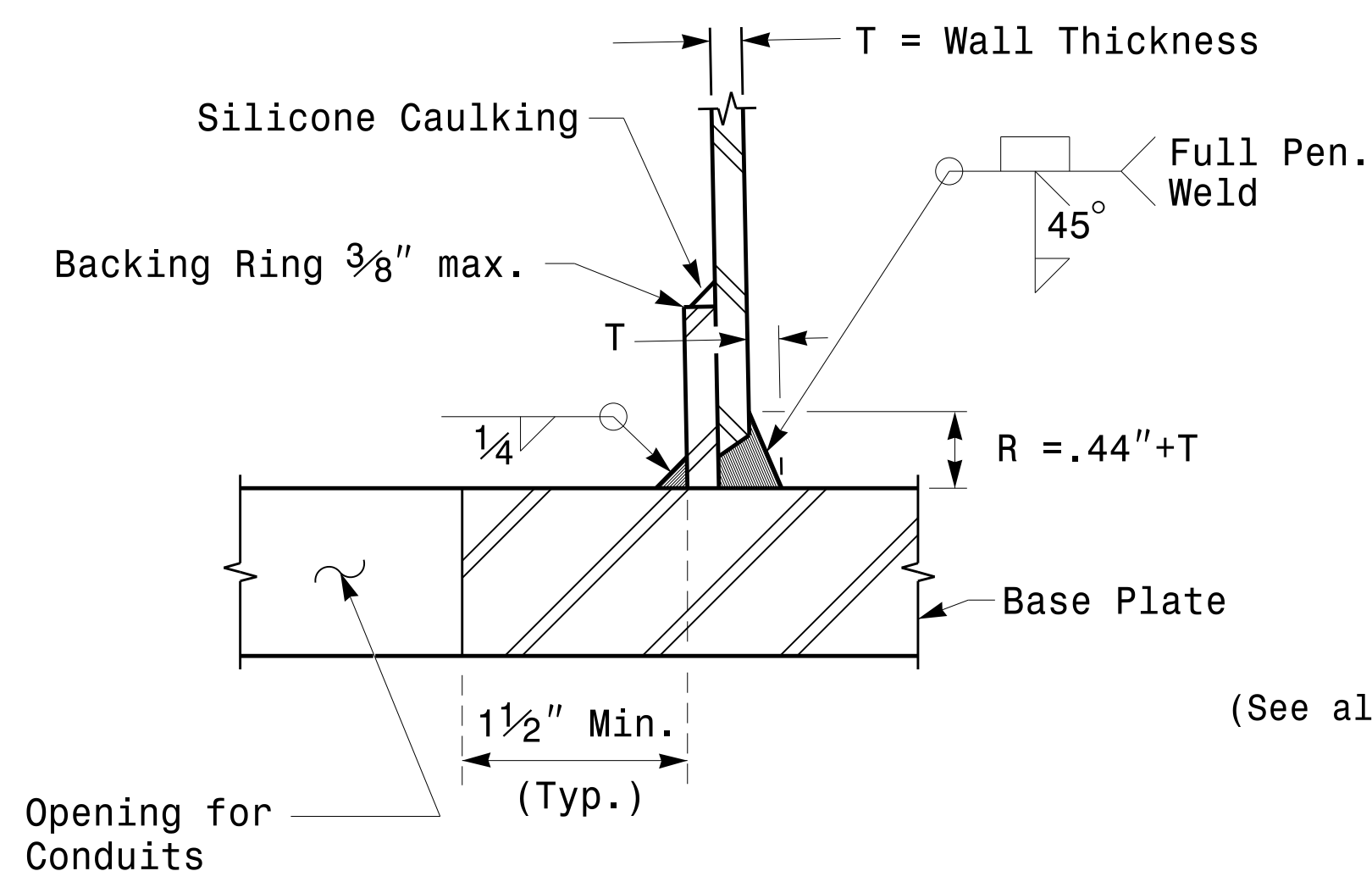

Section C-C Full-Penetration Groove Weld Detail (Pole Attachment to Base Plate)

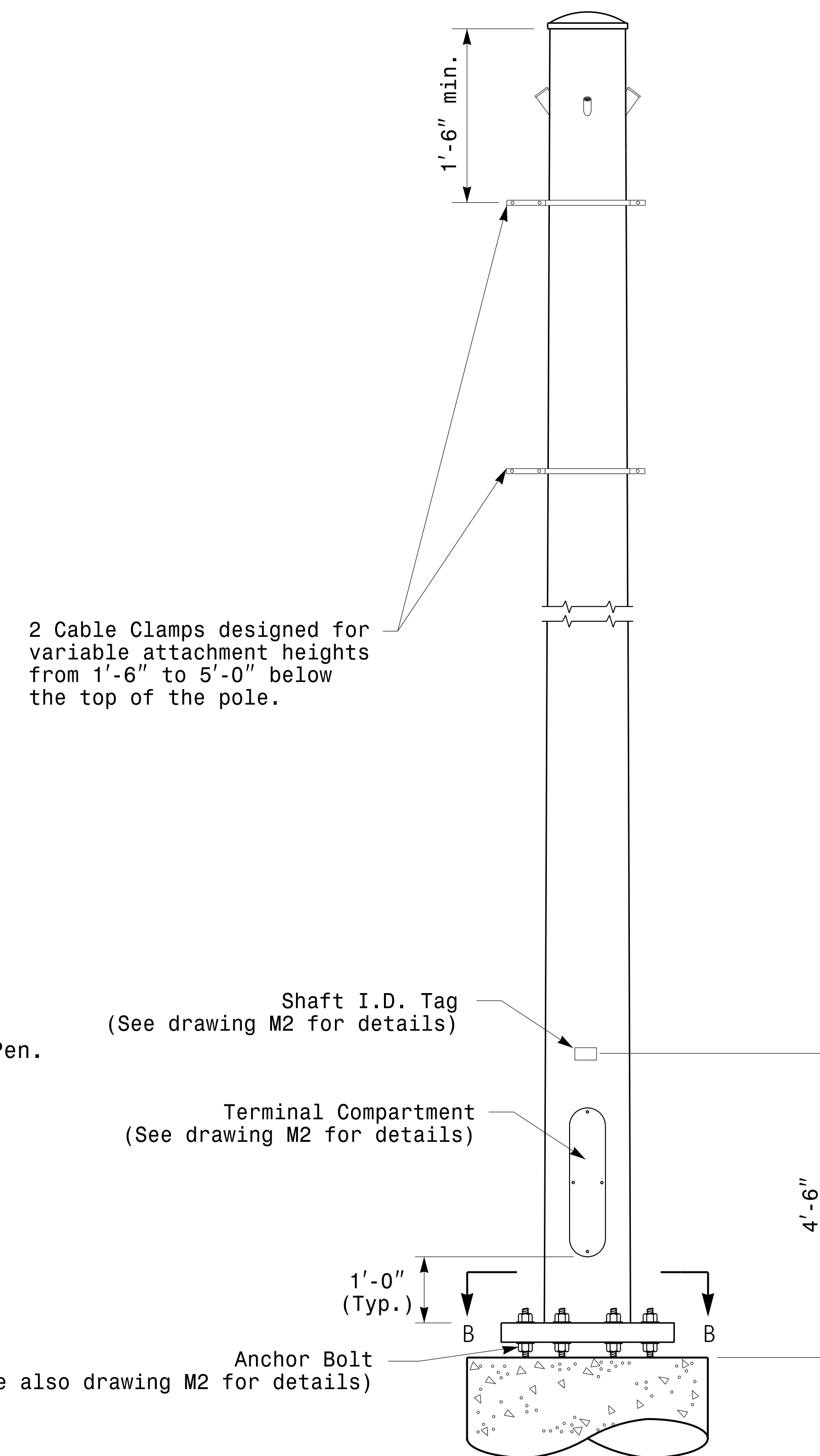

Monotube Strain Pole

Prepared in the Offices of:  
  
 750 N. Greenleaf Pkwy, Garner, NC 27529

SCALE: NONE

Typical Fabrication Details For Strain Poles

PLAN DATE: OCTOBER 2017	DESIGNED BY: K.C. DURIGON
PREPARED BY: N. BITTING	REVIEWED BY: D.C. SARKAR
REVISIONS	INIT. DATE

SEAL

DocuSigned by: D.C. Sarkar  
 44EB87816FA4F49E

10/11/2017  
 DATE

Fabrication Details - Strain Poles