

**PHASING DIAGRAM**

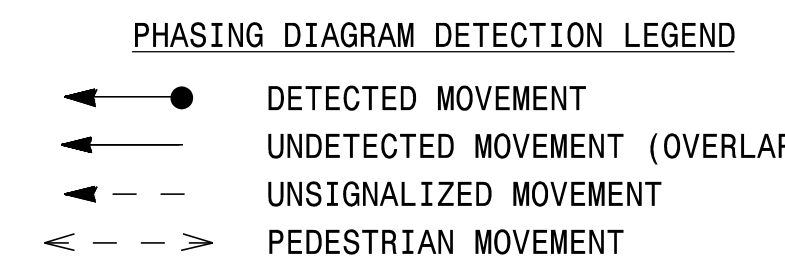
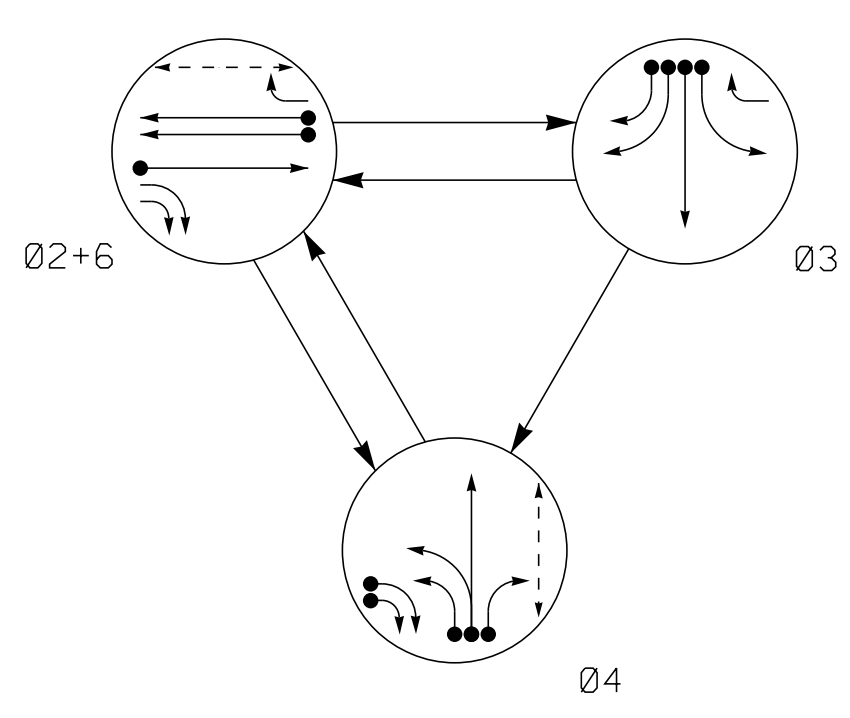

**TABLE OF OPERATION**

SIGNAL FACE	PHASE			
	Ø 2+6	Ø 3	Ø 4	Ø 4
21, 22	G	R	R	Y
23, 24, 25	→	R	→	→
31	R	G	R	R
32, 35	R	G	R	R
33, 34	R	→	R	R
41	R	R	→	→
42	R	R	G	R
43, 45	R	R	G	R
44	R	R	E	R
61, 62, 64	G	R	R	Y
63	→	R	→	→
P41, P42	DW	DW	W	DRK
P61, P62	W	DW	DW	DRK

**SIGNAL FACE I.D.**

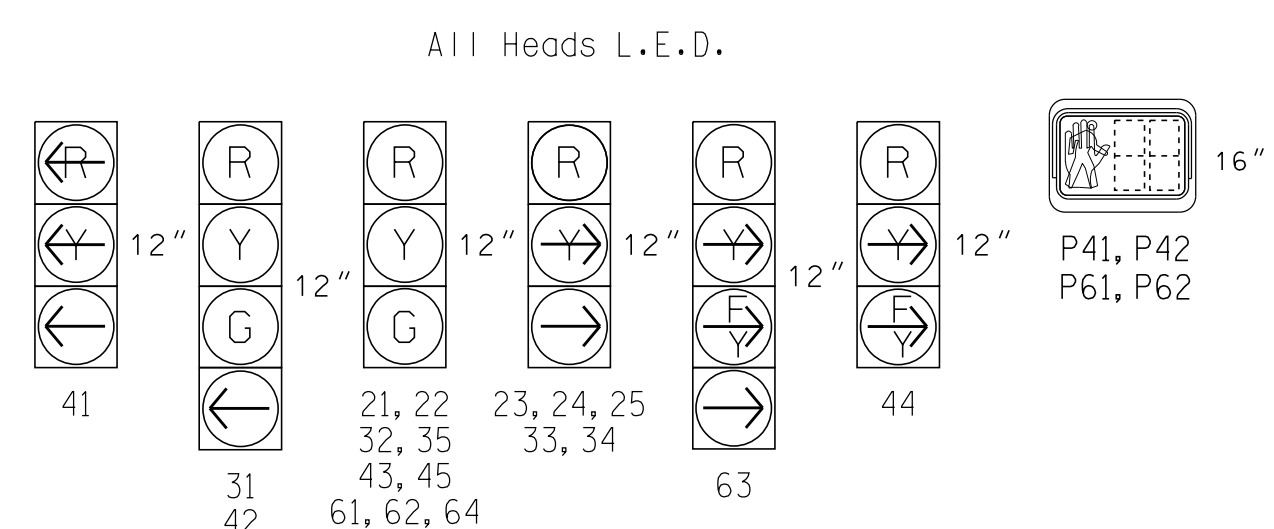

**ASC/3 DETECTOR INSTALLATION CHART**

LOOP	SIZE (FT)	DISTANCE FROM STOPBAR (FT)	TURNS	NEW LOOP	PROGRAMMING							
					PHASE	CALLING	EXTEND TIME	DELAY TIME	USE ADDED INITIAL	TYPE	SYSTEM LOOP	NEW CARD
2A	6X6	70	*	*	2	YES	-	-	-	N	-	*
3A, 3B	6X40	0	*	*	3	YES	-	-	-	N	-	*
3C, 3D	6X40	0	*	*	3	YES	-	-	-	N	-	*
4A, 4B	6X40	0	*	*	4	YES	-	-	-	N	-	*
4C	6X40	0	*	*	4	YES	-	15	-	N	-	*
4D, 4E	6X40	0	*	*	4	YES	-	-	-	N	-	*
6A, 6B	6X6	70	*	*	6	YES	-	-	-	N	-	*

\* Denotes Video Detection

**3 Phase Fully Actuated Cornelius CLS D10-18**

**NOTES**

- Refer to "Roadway Standard Drawings NCDOT" dated January 2018 and "Standard Specifications for Roads and Structures" dated January 2018, and all applicable sections of the latest version of the generic Project Special Provisions.
- Do not program signal for late night flashing operation unless otherwise directed by the Engineer.
- Reposition existing signal heads 31 and 32.
- Rename existing signal head 33 as 35 and reposition.
- Set all detector units to presence mode.
- All pedestrian signal equipment shall be placed on portable bases to allow for relocation as required by Division 10 traffic engineer.
- Pedestrian head and pushbutton signal cables shall be directly attached to overhead spanwire.
- Pedestrian pedestal locations to be determined by Division 10 traffic engineer.
- Omit "WALK" and flashing "DON'T WALK" with no pedestrian calls.
- Program pedestrian heads to countdown the flashing "Don't Walk" time only.
- Program controller to allow an Advanced Walk movement before serving the vehicle phase.
- This intersection uses video detection. Install detectors according to the manufacturer's instructions to achieve the desired detection.
- See C-5621 TMP Phase 4 for pavement markings and pedestrian detour plan.
- Portions of crosswalk and video detection zones masked for clarity.
- Maximum times shown in timing chart are for free-run operation only. Coordinated signal system timing values supersede these values.

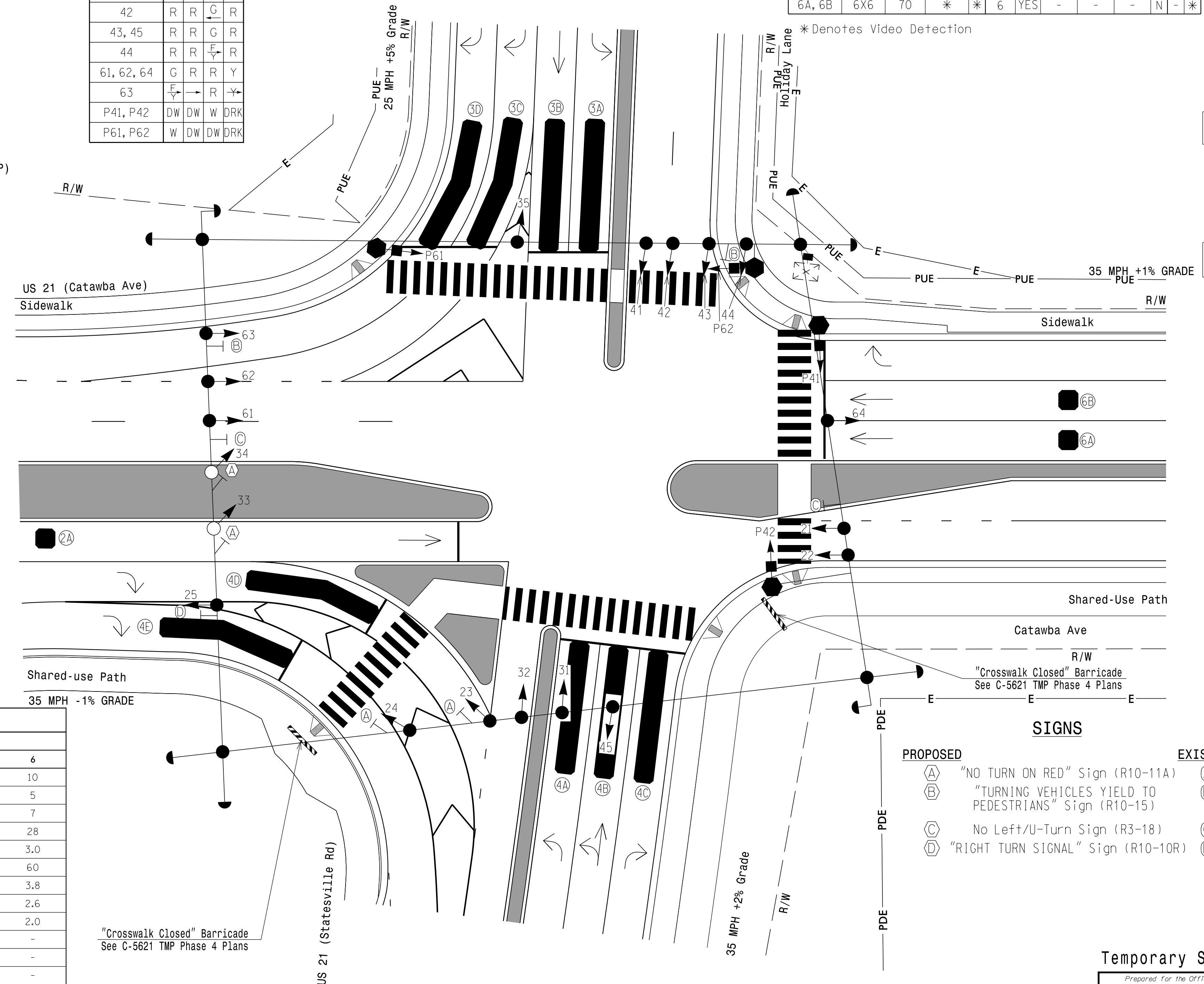

**ASC/3 TIMING CHART**

FEATURE	PHASE			
	2	3	4	6
Min Green *	10	7	7	10
Delayed Green	-	-	5	5
Walk *	-	-	7	7
Ped Clear	-	-	17	28
Veh. Extension *	3.0	2.0	2.0	3.0
Max I *	60	30	30	60
Yellow	3.9	3.0	3.7	3.8
Red Clear	2.0	3.7	2.6	2.6
Red Revert	2.0	2.0	2.0	2.0
Actuations B4 Add *	-	-	-	-
Seconds / Actuation *	-	-	-	-
Max Initial *	-	-	-	-
Time Before Reduction *	-	-	-	-
Time To Reduce *	-	-	-	-
Minimum Gap	-	-	-	-
Locking Detector	X	-	-	X
Recall Position	VEH. RECALL	-	-	VEH. RECALL
Dual Entry	-	-	-	-
Simultaneous Gap	X	X	X	X

\* These values may be field adjusted. Do not adjust Min Green and Extension times for phases 2 and 6 lower than what is shown. Min Green for all other phases should not be lower than 4 seconds.

**LEGEND**

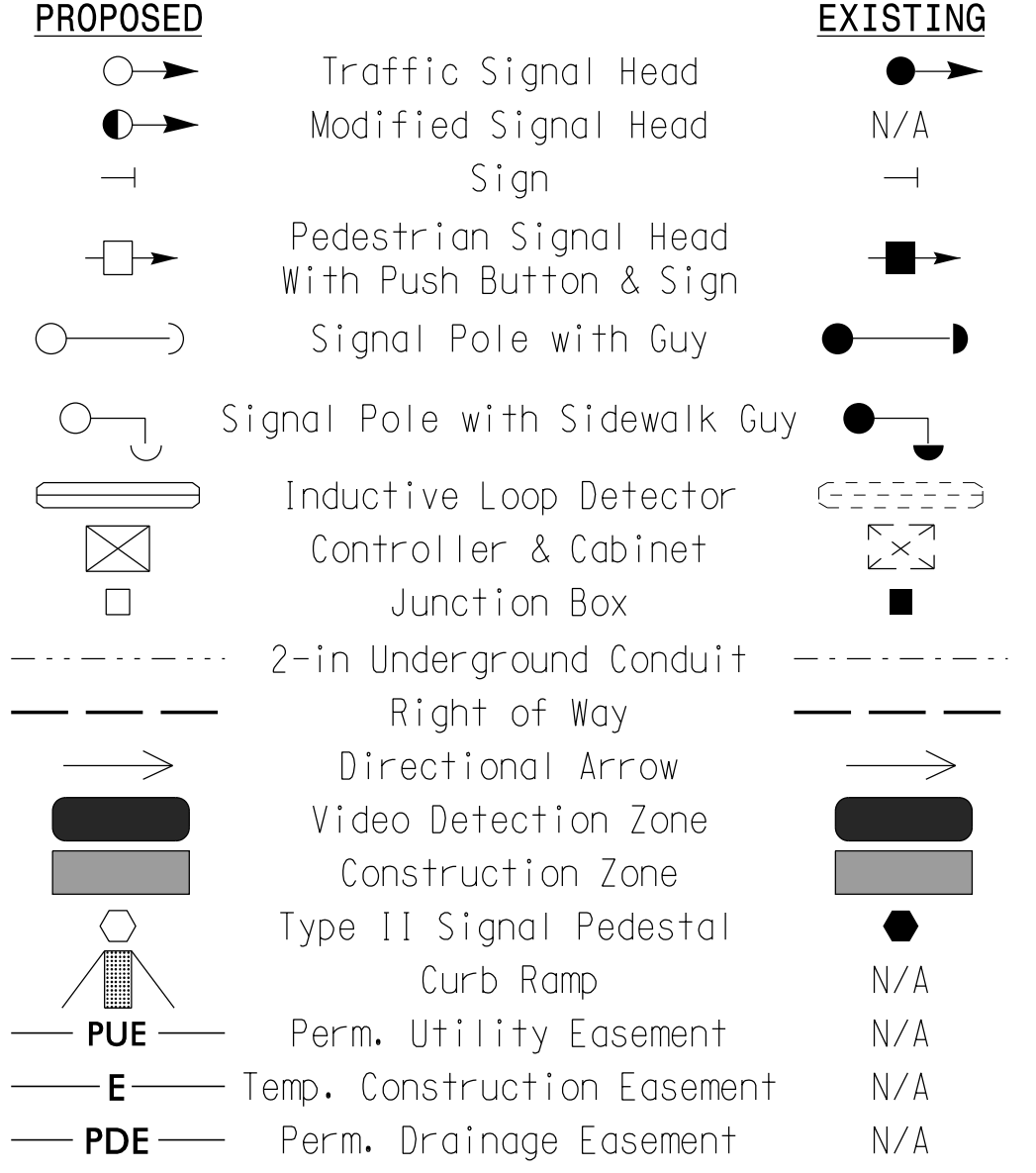

- SIGNS**
- |          |          |
|----------|----------|
| PROPOSED | EXISTING |
| (A)      | (A)      |
| (B)      | (B)      |
| (C)      | (C)      |
| (D)      | (D)      |
- (A) "NO TURN ON RED" Sign (R10-11A)
  - (B) "TURNING VEHICLES YIELD TO PEDESTRIANS" Sign (R10-15)
  - (C) No Left/U-Turn Sign (R3-18)
  - (D) "RIGHT TURN SIGNAL" Sign (R10-10R)

This plan supersedes the signal plan signed and sealed by S. Nick Matthews, PE on 05/31/2022.



**Temporary Signal 4 - TCP Phases 3B, 4**

US 21 (Catawba Avenue) / Catawba Avenue at US 21 (Statesville Road) / Holiday Lane

Division 10 Mecklenburg County Cornelius

PLAN DATE: February 2023 REVIEWED BY: S.G. Haynie

PREPARED BY: S.N. Matthews REVIEWED BY:

SEAL: S. NICK MATTHEWS, PE, 046989

DATE: 2/21/2023

Scale: 1" = 20'

P:\13-142-04\13-142-04.dwg  
 13-142-04.dwg  
 13-142-04