

8/17/99

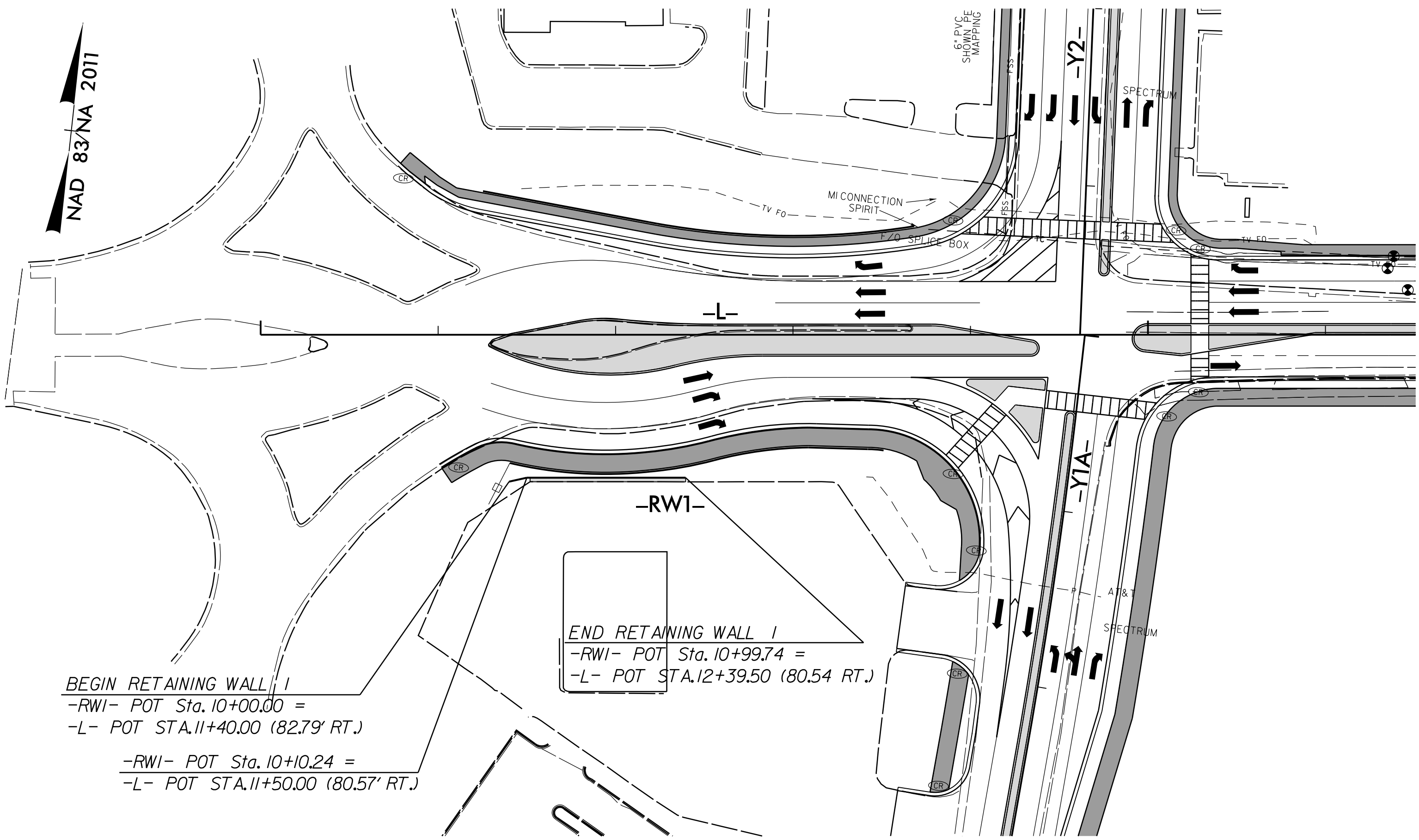

RETAINING WALL -RWI- DETAIL

PAVEMENT SCHEDULE			
C1	1.5" S9.5B	S2	4" MULTI-USE PATH
C2	3" S9.5CB	T	EARTH MATERIAL.
D1	4" I19.0C	U	EXISTING PAVEMENT.
E1	4" B25.0C	W	WEDGING
R1	2'-6" C&G		

PROJECT REFERENCE NO. C-5621	SHEET NO. 2B-9
ROADWAY DESIGN ENGINEER	

DOCUMENT NOT CONSIDERED FINAL UNLESS ALL SIGNATURES COMPLETED

RS&H 1520 SOUTH BOULEVARD, SUITE 200
CHARLOTTE, NC 28203
NC FIRM LICENSE No: F-0493

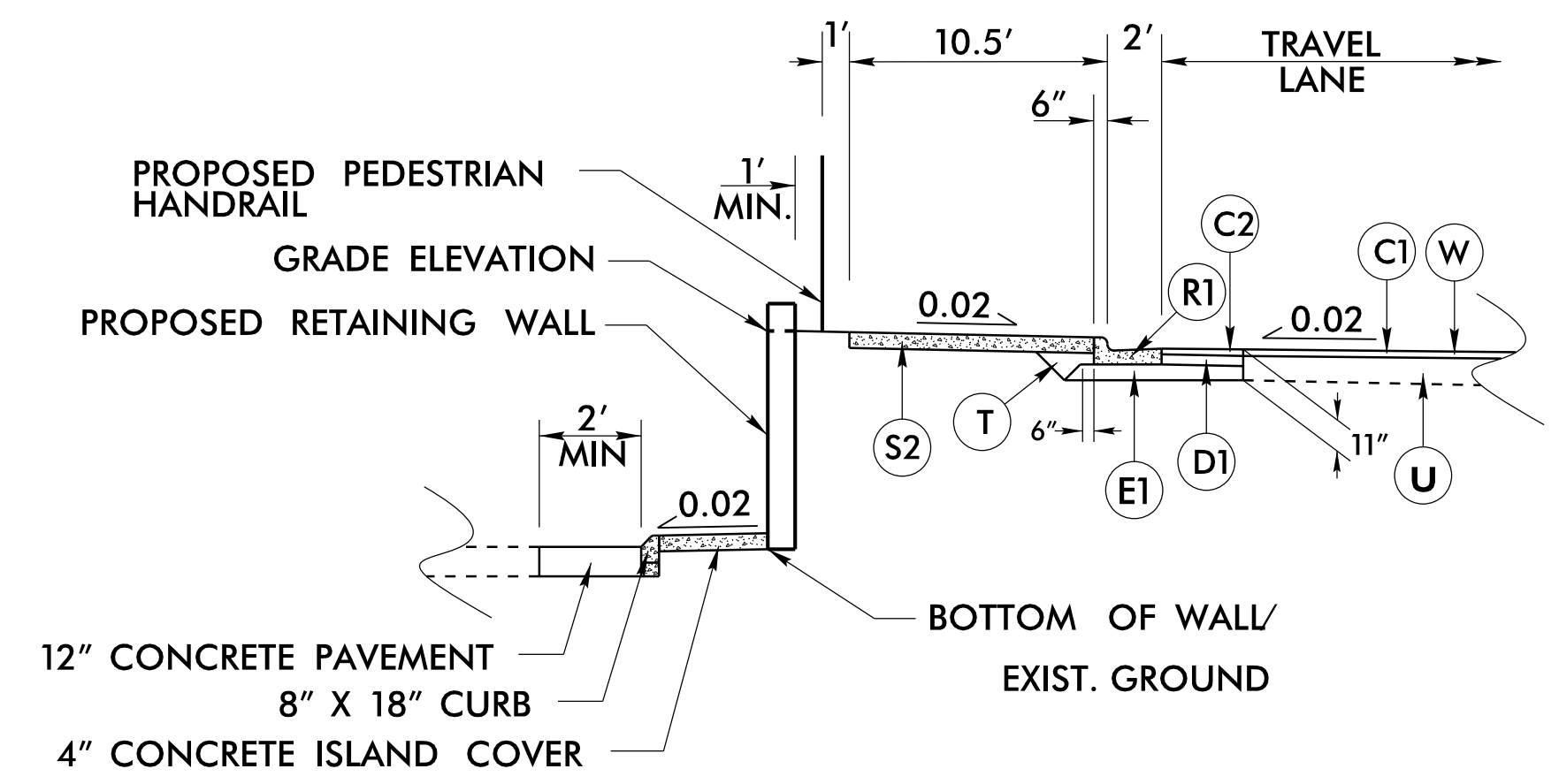

SECTION THROUGH RETAINING WALL
-RWI- STA. 10+00.00 TO -RWI- STA. 10+99.74

REPLACE 8"X18" CURB FROM -RWI- STA. 10+12.06 TO -RWI- STA. 10+99.74

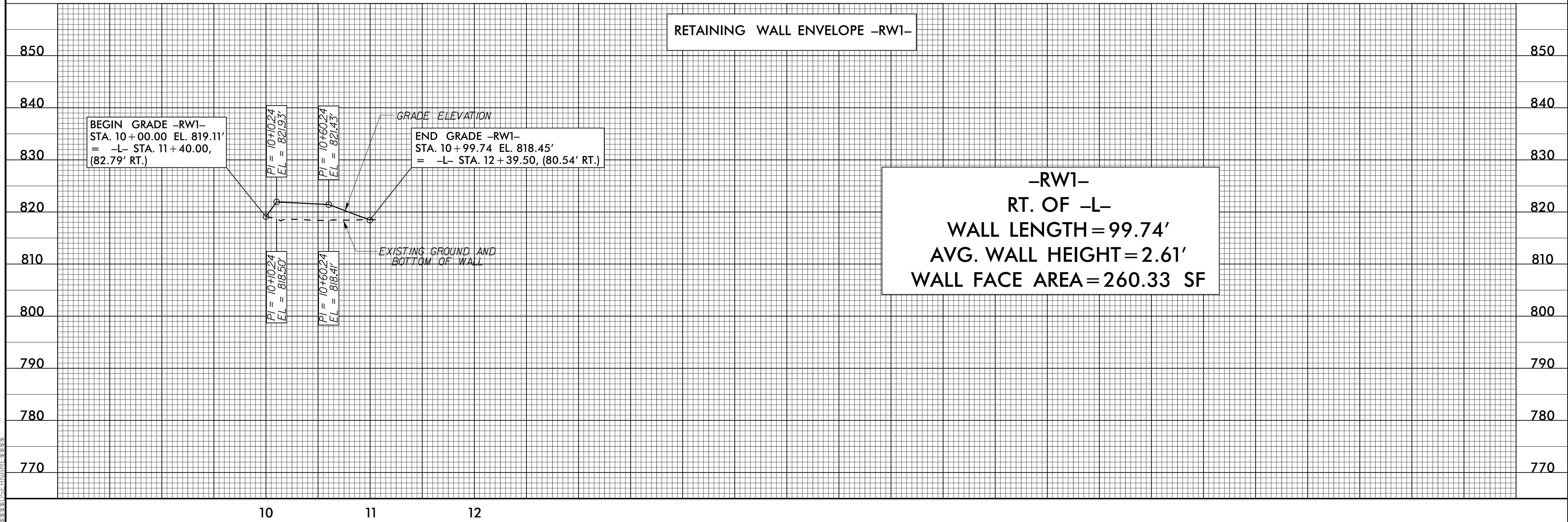

20-SEP-2023 10:10 AM
 R:\P\2023\2023-09-10\C-5621-Rdw_psh_retwal1.dgn
 \$\$\$\$DISPATCH\$\$\$\$