

EXISTING SECTION AT BENT
SECTIONS A-A & C-C

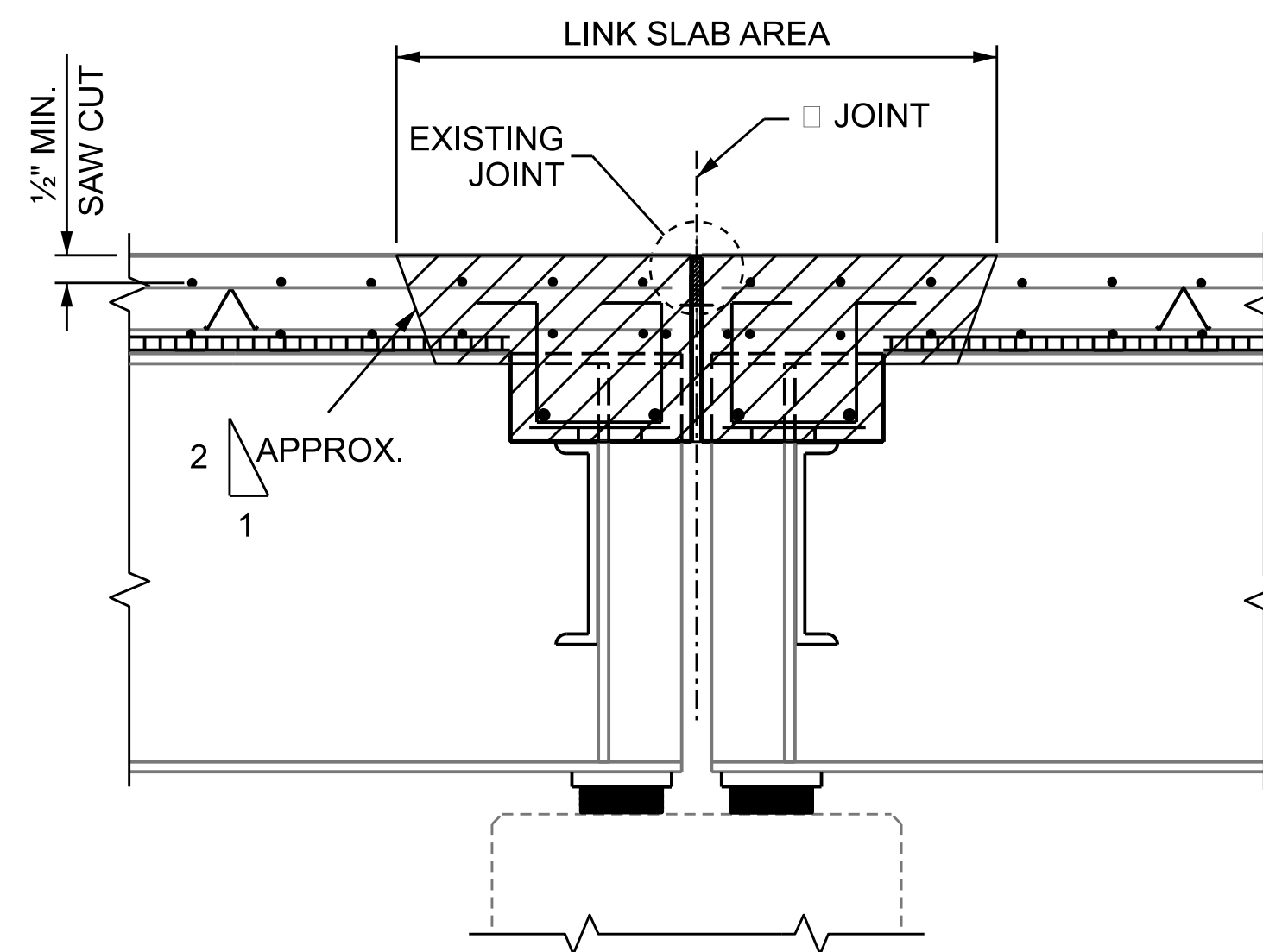

SPLICE LENGTHS		
BAR SIZE	EPOXY COATED	UNCOATED
#4	2'-0"	1'-9"
#5	2'-6"	2'-2"
#6	3'-0"	2'-7"

BILL OF MATERIAL													
LINK SLAB AT BENT 1						LINK SLAB AT BENT 3							
BAR NO.	SIZE	TYPE	LENGTH	WEIGHT		BAR NO.	SIZE	TYPE	LENGTH	WEIGHT			
* A	20	#5	STR	33'-8"	702	* A	31	#5	STR	33'-8"	1089		
A	20	#5	STR	33'-8"	702	A	31	#5	STR	33'-8"	1089		
* B	67	#6	STR	8'-8"	872	* B	67	#6	STR	13'-8"	1375		
B	67	#6	STR	8'-8"	872	B	67	#6	STR	13'-8"	1375		
REINFORCING STEEL					LBS.	1574	REINFORCING STEEL					LBS.	2464
EPOXY COATED							EPOXY COATED						
* REINFORCING STEEL					LBS.	1574	* REINFORCING STEEL					LBS.	2464
CLASS AA CONCRETE					C.Y.	7.0	CLASS AA CONCRETE					C.Y.	10.5

NOTES

- SEE TRAFFIC MANAGEMENT PLANS FOR LANE WIDTHS, SEQUENCING, AND OTHER TRAFFIC CONTROL MEASURES FOR STAGING OF JOINT REPAIR.
- FOR ESTIMATED LINK SLAB FOR PRESERVATION QUANTITIES, SEE PLAN OF SPAN SHEETS.
- FOR LINK SLAB FOR PRESERVATION, SEE SPECIAL PROVISIONS.

CONSTRUCTION SEQUENCE

- CLOSE WORK AREA ACCORDING TO TRAFFIC MANAGEMENT PLANS.
- MARK OUT PROPOSED LINK SLAB AREA AND REMOVE EXISTING JOINT MATERIAL.
- SAW CUT 1/2" DEEP PERIMETER OF PROPOSED LINK SLAB AREA.
- BEGIN FULL DEPTH DEMOLITION OF PROPOSED LINK SLAB AREA, BEING CAREFUL NOT TO DAMAGE EXISTING REINFORCING STEEL, BEAM FLANGES, OR STAY-IN-PLACE FORMS. DEMOLISH EDGES OF LINK SLAB AREA AT A 2:1 RATIO, AS SHOWN.
- REMOVE DEMOLITIONED MATERIALS AND CLEAN LINK SLAB AREA.
- REMOVE SHEAR STUDS/STIRRUPS WITHIN THE LINK SLAB AREA.
- REPAIR EXISTING REINFORCING STEEL THAT WAS DAMAGED DURING DEMOLITION.
- PLACE BOND BREAKER MATERIAL WITHIN THE LINK SLAB AREA.
- PLACE ADDITIONAL REINFORCING STEEL AS SHOWN.
- PLACE NEW CONCRETE FOLLOWING THE LINK SLAB FOR PRESERVATION SPECIAL PROVISION. AS AN ALTERNATIVE, THE CONTRACTOR CAN USE LMC MATERIAL FOR THE LINK SLAB, FOLLOWING THE LATEX MODIFIED CONCRETE - EARLY STRENGTH BRIDGE DECK OVERLAY SPECIAL PROVISION.
- AFTER PROPOSED DECK OVERLAY WORK HAS CURED, SAW CUT CONTROL LINES AND FILL WITH SEALER MATERIAL.

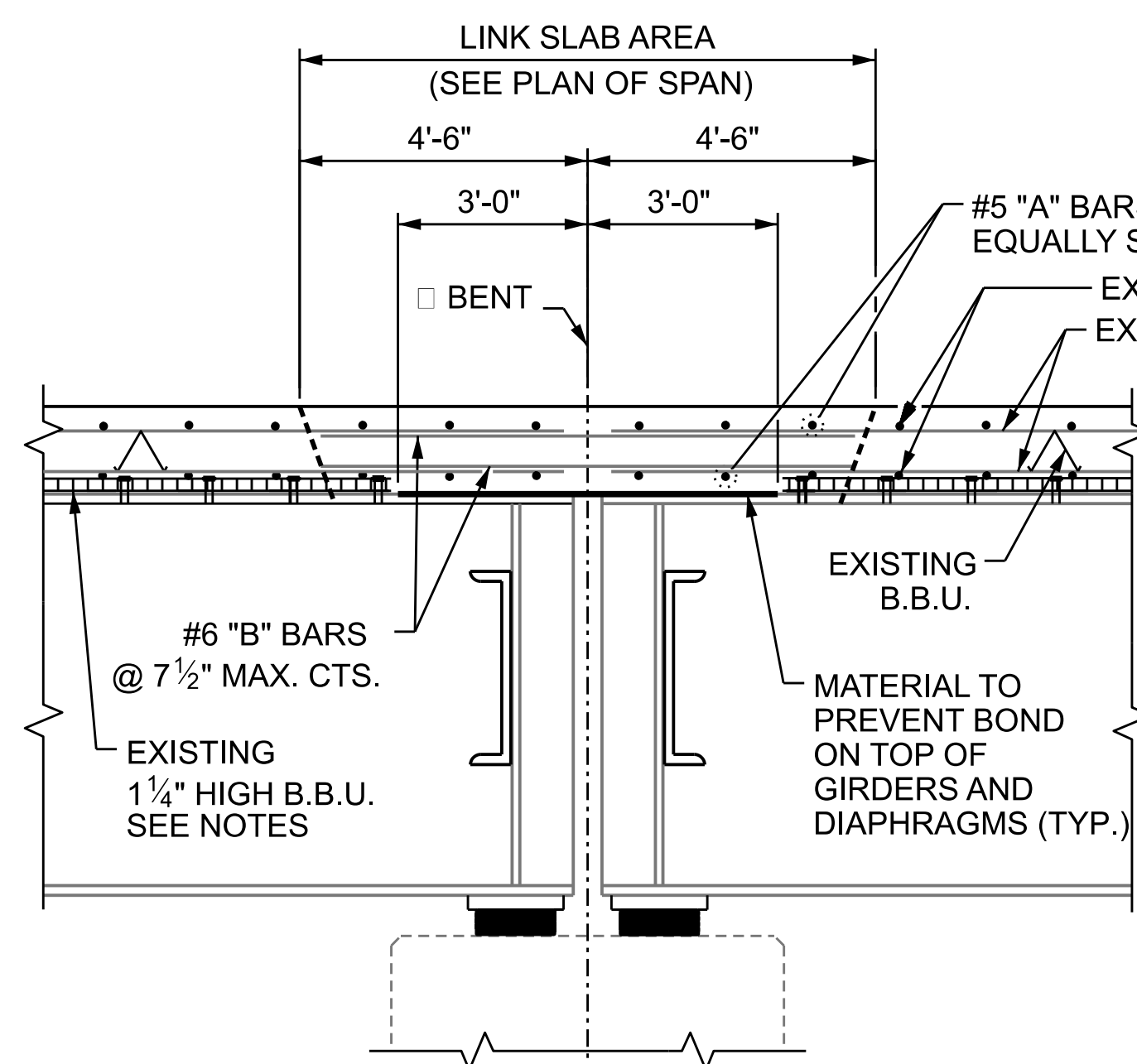

SECTION A-A
BENT 1

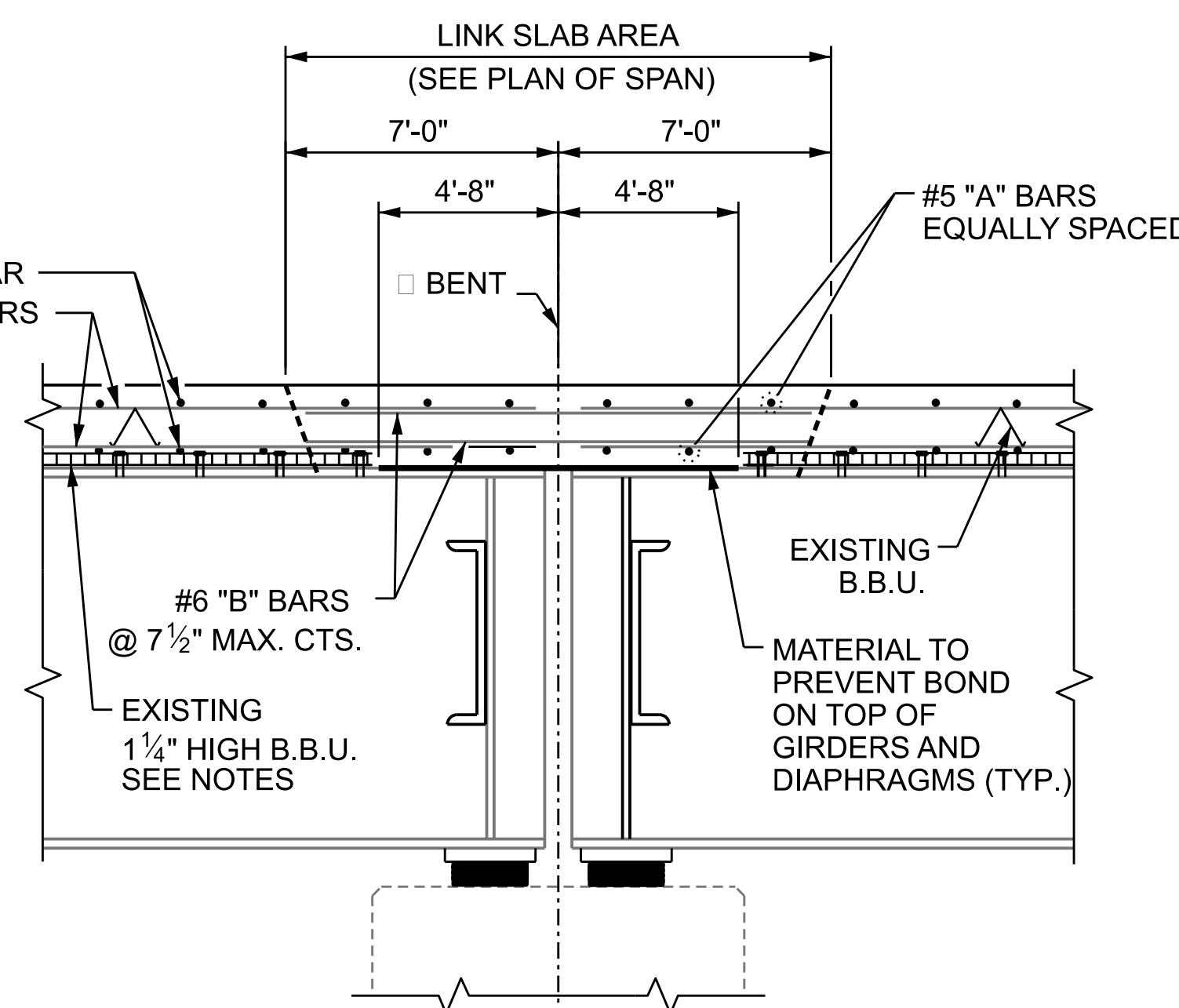

SECTION C-C
BENT 3

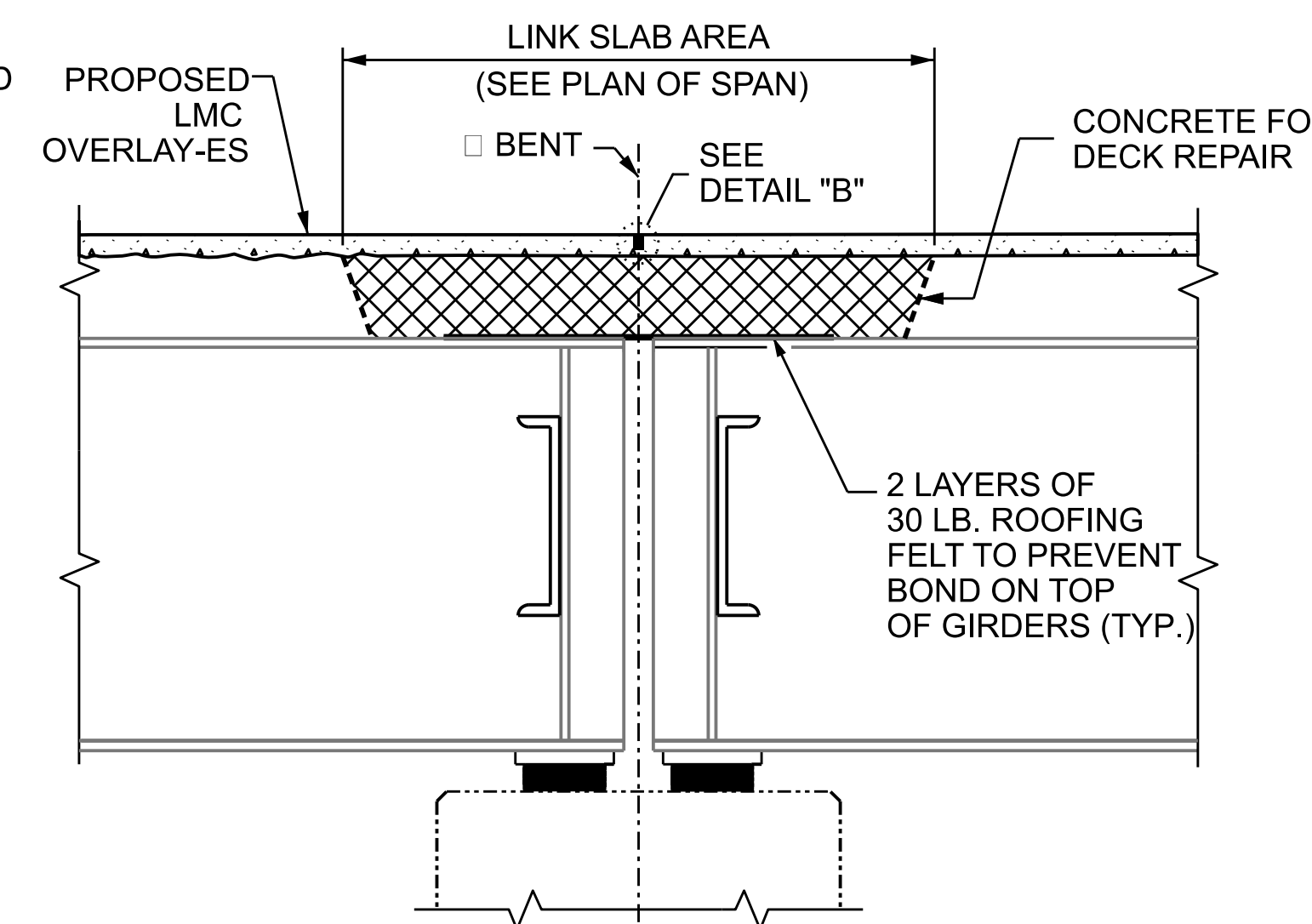

PROPOSED SECTION AT BENT

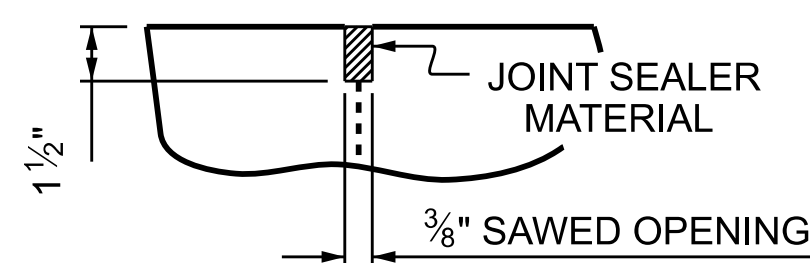

DETAIL "B"

A 1/2" DEEP CONTRACTION JOINT AT BENT CONTROL LINE SHALL BE SAWN WITHIN 24 HOURS OF POURING THE LINK SLAB AND OVERLAY. THE JOINT SHALL BE FILLED WITH JOINT SEALER MATERIAL. THE JOINT SEALER MATERIAL SHALL CONFORM TO THE REQUIREMENTS OF TYPE B LOW MODULUS SILICONE SEALANT. SEE SECTION 1028 OF THE STANDARD SPECIFICATIONS.

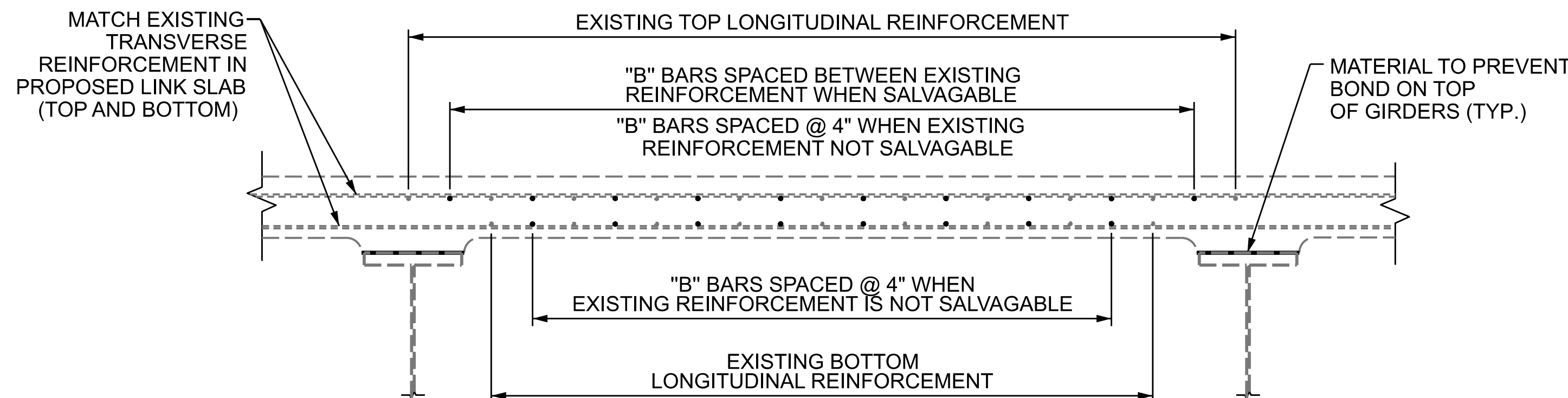

REINFORCEMENT DETAILS

PROJECT NO. 15BPR.125.3
CHEROKEE COUNTY
BRIDGE NO. 190009

SHEET 2 OF 2



STATE OF NORTH CAROLINA
DEPARTMENT OF TRANSPORTATION
RALEIGH

LINK SLAB FOR PRESERVATION JOINT DETAILS

DRAWN BY : A. SORSENGINH DATE : 9/2020
CHECKED BY : S. A. HERNANDEZ DATE : 9/2020
DESIGN ENGINEER OF RECORD : A. SORSENGINH DATE : 9/2020

DOCUMENT NOT CONSIDERED FINAL UNLESS ALL SIGNATURES COMPLETED

REVISIONS				SHEET NO.
NO.	BY:	DATE:	NO.	DATE:
1			3	
2			4	

TOTAL SHEETS: 25