

8/17/23

bwhite
8/25/2023
c:\pwworking\gfpw01\white\dl51332\HE-001_rdy_psh05_2_LANES_NARROW.dgn

PROJECT REFERENCE NO. HE-0011	SHEET NO. 5
RW SHEET NO.	
ROADWAY DESIGN ENGINEER	HYDRAULICS ENGINEER
DOCUMENT NOT CONSIDERED FINAL UNLESS ALL SIGNATURES COMPLETED	

NAD 83/2011

**MATCHLINE SHEET 4
-L- STA 21+00.00**

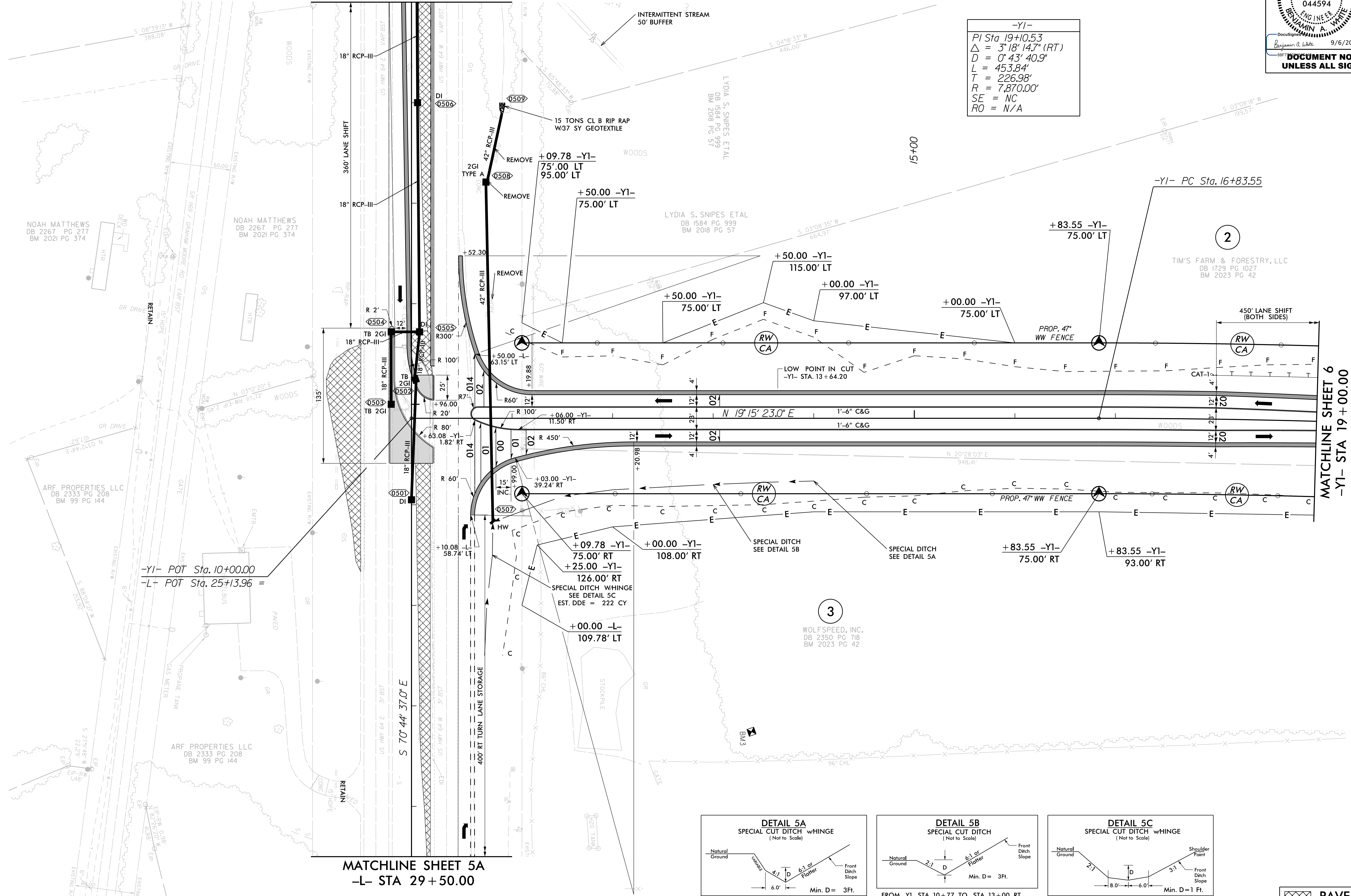

-Y1-
 PI Sta 19+10.53
 $\Delta = 3'18''14.7'' (RT)$
 $D = 0'43''40.9''$
 $L = 453.84'$
 $T = 226.98'$
 $R = 7,870.00'$
 $SE = NC$
 $RO = N/A$

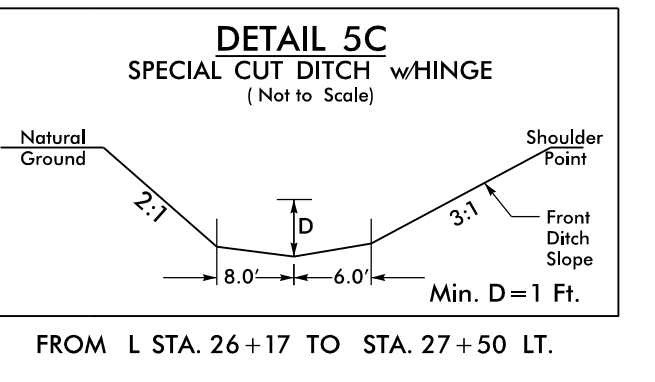
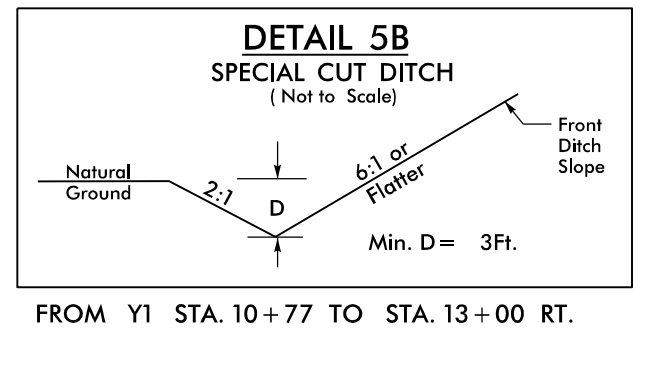
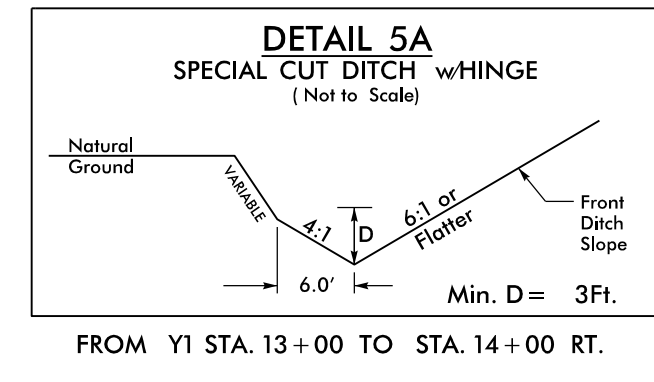

PAVEMENT REMOVAL

**FOR -L- PROFILE SEE SHEET 8
FOR -Y1- PROFILE SEE SHEET 9**