



STATE OF NORTH CAROLINA
DEPARTMENT OF TRANSPORTATION

ROY COOPER
GOVERNOR

J.R. "JOEY" HOPKINS
SECRETARY

October 5, 2023

Addendum No. 1

RE: Contract # C204488

WBS # 15BPR.125.3

STATE FUNDED

Cherokee County

BRIDGE #190009 AND #190010 OVER NOTTELY RIVER AND GRAVEL RD ON
US-64 & US-74.

October 17, 2023 Letting

To Whom It May Concern:

Reference is made to the proposal and plans furnished to you on this project.

The following revisions have been made to the Traffic Management Plans.

Sheet No.	Revision
TMP-1	Index of Sheets updated.
TMP-1B	Note "I" was added in addition to PCB notes and Time Restriction changes.
TMP-1C (New)	Phasing was re-written to include the 15-day lane closure ICT (per lane), for the bridge work.
TMP-2	Typical Sections to include the barrier for the long-term lane closure.
TMP-3	Plan View to show the new traffic setup for the long-term lane closure, to include, but is not limited to stationary signs, PCB (anchored), crash cushion, temp PM, drums, etc.

Please void the above listed Sheets in your Plans and staple the revised Sheets thereto.
Staple New Sheet TMP-1C after revised Sheet TMP-1B in your plans.

The following revisions have been made to the proposal.

Mailing Address:
NC DEPARTMENT OF TRANSPORTATION
CONTRACT STANDARDS AND DEVELOPMENT
1591 MAIL SERVICE CENTER
RALEIGH, NC 27699-1591

Telephone: (919) 707-6900
Fax: (919) 250-4127
Customer Service: 1-877-368-4968

Location:
1020 BIRCH RIDGE DR.
RALEIGH, NC 27610

Website: www.ncdot.gov

Page No.	Revision
Proposal Cover	Note added that reads “Includes Addendum No. 1 Dated 10-05-2023”.
Table of Contents	Updated to reflect changes below.
G-4 thru G-5	The Project Special Provision entitled INTERMEDIATE CONTRACT TIME NUMBER 1 AND LIQUIDATED DAMAGES has been revised.
G-5 thru G-25	The Project Special Provision entitled INTERMEDIATE CONTRACT TIME NUMBER 2 AND LIQUIDATED DAMAGES has been revised.
G-29	The Project Special Provision entitled PORTABLE CONCRETE BARRIER-(Partial Payments for Materials) has been added.

Please void the above listed existing Pages in your proposal and staple the revised Pages thereto.

On the item sheets the following pay item revisions have been made:

<u>Item</u>	<u>Description</u>	<u>Old Quantity</u>	<u>New Quantity</u>
0005-4400000000-E 1110	WORK ZONE SIGNS (STATIONARY)	240 SF	560 SF
0007-4415000000-N 1115	FLASHING ARROW BOARD	2 EA	4 EA
0008-4420000000-N 1120	PORTABLE CHANGEABLE MESSAGE SIGN	1 EA	2 EA
0009-4430000000-N 1130	DRUMS	45 EA	100 EA
0010-4434000000-N SP	SEQUENTIAL FLASHING WARNING LIGHTS	15 EA	30 EA
0013-4770000000-E 1205	COLD APPLIED PLASTIC PAVEMENT MARKING LINES, TYPE IV (4")	4,600 LF	13,000 LF
0014-4810000000-E 1205	PAINT PAVEMENT MARKING LINES (4")	9,800 LF	22,200 LF
0042-4465000000-N 1160	TEMPORARY CRASH CUSHIONS	NEW ITEM	2 EA

<u>Item</u>	<u>Description</u>	<u>Old Quantity</u>	<u>New Quantity</u>
0043-4470000000-N 1160	REMOVE & RESET TEMPORARY CRASH CUSHION	NEW ITEM	2 EA
0044-4490000000-E 1170	PORTABLE CONCRETE BARRIER (ANCHORED)	NEW ITEM	1,080 LF
0045-4505000000-E 1170	REMOVE & RESET PORTABLE CONCRETE BARRIER (ANCHORED)	NEW ITEM	1,080 LF

The Contractor's bid must include these pay item revisions.

The electronic bidding file has been updated to reflect these revisions. Please download the Addendum File and follow the instructions for applying the addendum. Bid Express will not accept your bid unless the addendum has been applied.

The contract will be prepared accordingly.

Sincerely,

DocuSigned by:

 F81B6038A47A442...

Ronald E. Davenport, Jr., PE
 State Contract Officer

RED/cms
 Attachments

cc: Mr. Boyd Tharrington, PE
 Ms. Wanda H. Payne, PE
 Mr. Ken Kennedy, PE
 Mr. Mike Gwyn
 Project File (2)

Mr. Forrest Dungan, PE
 Ms. Jaci Kincaid
 Mr. Jon Weathersbee, PE

STATE OF NORTH CAROLINA
DEPARTMENT OF TRANSPORTATION
RALEIGH, N.C.

PROPOSAL

INCLUDES ADDENDUM NO 1 DATED 10-05-2023

DATE AND TIME OF BID OPENING: **Oct 17, 2023 AT 02:00 PM**

CONTRACT ID C204488

WBS 15BPR.125.3

FEDERAL-AID NO. STATE FUNDED

COUNTY CHEROKEE

T.I.P NO.

MILES 0.142

ROUTE NO. US-64

LOCATION BRIDGE #190009 AND #190010 OVER NOTTELY RIVER AND GRAVEL RD
ON US-64 & US-74.

TYPE OF WORK BRIDGE PRESERVATION.

NOTICE:

ALL BIDDERS SHALL COMPLY WITH ALL APPLICABLE LAWS REGULATING THE PRACTICE OF GENERAL CONTRACTING AS CONTAINED IN CHAPTER 87 OF THE GENERAL STATUTES OF NORTH CAROLINA WHICH REQUIRES THE BIDDER TO BE LICENSED BY THE N.C. LICENSING BOARD FOR CONTRACTORS WHEN BIDDING ON ANY NON-FEDERAL AID PROJECT WHERE THE BID IS \$30,000 OR MORE, EXCEPT FOR CERTAIN SPECIALTY WORK AS DETERMINED BY THE LICENSING BOARD. BIDDERS SHALL ALSO COMPLY WITH ALL OTHER APPLICABLE LAWS REGULATING THE PRACTICES OF ELECTRICAL, PLUMBING, HEATING AND AIR CONDITIONING AND REFRIGERATION CONTRACTING AS CONTAINED IN CHAPTER 87 OF THE GENERAL STATUTES OF NORTH CAROLINA. NOTWITHSTANDING THESE LIMITATIONS ON BIDDING, THE BIDDER WHO IS AWARDED ANY FEDERAL - AID FUNDED PROJECT SHALL COMPLY WITH CHAPTER 87 OF THE GENERAL STATUTES OF NORTH CAROLINA FOR LICENSING REQUIREMENTS WITHIN 60 CALENDAR DAYS OF BID OPENING.

BIDS WILL BE RECEIVED AS SHOWN BELOW:

THIS IS A STRUCTURE PROPOSAL

5% BID BOND OR BID DEPOSIT REQUIRED

TABLE OF CONTENTS

**COVER SHEET
PROPOSAL SHEET**

PROJECT SPECIAL PROVISIONS

CONTRACTOR PREQUALIFICATION:..... G-1
 INTERESTED PARTIES LIST:..... G-2
 LIABILITY INSURANCE:..... G-3
 CONTRACT TIME AND LIQUIDATED DAMAGES: G-3
 INTERMEDIATE CONTRACT TIME NUMBER 1 AND LIQUIDATED DAMAGES: G-4
 INTERMEDIATE CONTRACT TIME NUMBER 2 AND LIQUIDATED DAMAGES: G-5
 MAJOR CONTRACT ITEMS: G-5
 SPECIALTY ITEMS:..... G-6
 SPECIAL REQUIREMENTS FOR WORK IN NATIONAL FOREST:..... G-6
 FUEL PRICE ADJUSTMENT:..... G-8
 SCHEDULE OF ESTIMATED COMPLETION PROGRESS:..... G-9
 MINORITY BUSINESS ENTERPRISE AND WOMEN BUSINESS ENTERPRISE: G-10
 RESTRICTIONS ON ITS EQUIPMENT AND SERVICES:..... G-25
 USE OF UNMANNED AIRCRAFT SYSTEM (UAS): G-25
 EQUIPMENT IDLING GUIDELINES:..... G-25
 REMOVABLE PAVEMENT MARKINGS - (Partial Payments for Materials):..... G-26
 MAINTENANCE OF THE PROJECT: G-26
 ELECTRONIC BIDDING:..... G-27
 AWARD LIMITS: G-28
 TWELVE MONTH GUARANTEE:..... G-28
 OUTSOURCING OUTSIDE THE USA: G-29
 NOTE TO CONTRACTOR: G-29
 PORTABLE CONCRETE BARRIER - (Partial Payments for Materials):..... G-29

 ROADWAY..... R-1

STANDARD SPECIAL PROVISIONS

AVAILABILITY FUNDS – TERMINATION OF CONTRACTS..... SSP-1
 NCDOT GENERAL SEED SPECIFICATION FOR SEED QUALITY SSP-2
 ERRATA..... SSP-5
 PLANT AND PEST QUARANTINES SSP-13
 MINIMUM WAGES SSP-14
 TITLE VI AND NONDISCRIMINATION SSP-15
 ON-THE-JOB TRAINING SSP-23

UNIT PROJECT SPECIAL PROVISIONS

TRAFFIC CONTROL TC-1
 EROSION CONTROL EC-1
 STRUCTURE / CULVERTS..... BP-1

PROPOSAL ITEM SHEET

ITEM SHEET(S)

INTERMEDIATE CONTRACT TIME NUMBER 1 AND LIQUIDATED DAMAGES:

(2-20-07)

108

SP1 G14 A

The Contractor shall complete the required work of installing, maintaining, and removing the traffic control devices for lane closures and restoring traffic to the existing traffic pattern. The Contractor shall not close or narrow a lane of traffic on **US 64 / US 74** during the following time restrictions:

DAY AND TIME RESTRICTIONS**Monday thru Friday, 7:00 A.M. to 9:00 A.M. and 4:00 P.M. to 6:00 P.M.**

The Contractor shall not narrow or close a lane of traffic on **US 64 / US 74**, detain and /or alter the traffic flow on or during holiday weekends, special events, or any other time when traffic is unusually heavy, including the following schedules:

HOLIDAY AND HOLIDAY WEEKEND LANE CLOSURE RESTRICTIONS

1. For **unexpected occurrence** that creates unusually high traffic volumes, as directed by the Engineer.
2. For **New Year's Day**, between the hours of **7:00 A.M.** December 31st and **6:00 P.M.** January 2nd. If New Year's Day is on a Friday, Saturday, Sunday or Monday, then until **6:00 P.M.** the following Tuesday.
3. For **Easter**, between the hours of **7:00 A.M.** Thursday and **6:00 P.M.** Monday.
4. For **Memorial Day**, between the hours of **7:00 A.M.** Friday and **6:00 P.M.** Tuesday.
5. For **Independence Day**, between the hours of **7:00 A.M.** the day before Independence Day and **6:00 P.M.** the day after Independence Day.

If **Independence Day** is on a Friday, Saturday, Sunday or Monday, then between the hours of **7:00 A.M.** the Thursday before Independence Day and **6:00 P.M.** the Tuesday after Independence Day.
6. For **Labor Day**, between the hours of **7:00 A.M.** Friday and **6:00 P.M.** Tuesday.
7. For **Thanksgiving**, between the hours of **7:00 A.M.** Tuesday and **6:00 P.M.** Monday.
8. For **Christmas**, between the hours of **7:00 A.M.** the Friday before the week of Christmas Day and **6:00 P.M.** the following Tuesday after the week of Christmas Day.
9. For **Leaf Season**, each weekend between October 12th and October 31st, between the hours of **7:00 A.M.** Friday and **6:00 P.M.** the following Monday.

Holidays and holiday weekends shall include New Year's, Easter, Memorial Day, Independence Day, Labor Day, Thanksgiving, and Christmas. The Contractor shall schedule his work so that lane closures are not required during these periods, unless otherwise directed by the Engineer.

The time of availability for this intermediate contract work shall be the time the Contractor begins to install all traffic control devices for lane closures according to the time restrictions listed herein.

The completion time for this intermediate contract work shall be the time the Contractor is required to complete the removal of all traffic control devices for lane closures according to the time restrictions stated herein and place traffic in the existing traffic pattern.

The liquidated damages are **Five Hundred Dollars (\$ 500.00)** per hour. **The liquidated damages associated with Day and Time Restrictions will not apply to US 64 / US 74 when lane closures are required by Steps #2A thru #2D of the Phasing, as shown on Sheet TMP-1C. The liquidated damages associated with Holiday and Holiday Weekend Lane Closure Restrictions shall apply throughout the entire duration of the project.**

INTERMEDIATE CONTRACT TIME NUMBER 2 AND LIQUIDATED DAMAGES:

(2-20-07) (Rev. 6-18-13)

108

SP1 G14 H

The Contractor shall complete the work required of **Phase I, Steps #2A thru #2D** as shown on Sheet **TMP-1C** and shall place and maintain traffic on same. **The Contractor may utilize this intermediate contract time four (4) times, once for each lane of US 64 / US 74. No work required of this Intermediate Contract Time may occur during the Leaf Season, as described in Intermediate Contract Time Number 1.**

The date of availability for **each independent** intermediate contract time is the date the Contractor elects to begin the work.

The completion date for **each independent** intermediate contract time is the date which is **fifteen (15)** consecutive calendar days after and including the date of availability.

The liquidated damages for **each independent** intermediate contract time are **Seven Hundred Fifty Dollars (\$ 750.00)** per calendar day.

MAJOR CONTRACT ITEMS:

(2-19-02)

104

SP1 G28

The following listed items are the major contract items for this contract (see Article 104-5 of the *2018 Standard Specifications*):

Line #	Description
21	Latex Modified Concrete Overlay
22	Placing & Finishing of Latex Modified Concrete Overlay
24	Shotcrete Repairs
37	Link Slab for Preservation
38	Hydro-Demolition of Bridge Deck

SPECIALTY ITEMS:

(7-1-95)(Rev. 7-20-21)

108-6

SP1 G37

Items listed below will be the specialty items for this contract (see Article 108-6 of the 2018 Standard Specifications).

Line #	Description
13	Removable Tape
16	Permanent Pavement Markers
19, 26-29, 40	Bridge Painting

SPECIAL REQUIREMENTS FOR WORK IN NATIONAL FOREST:

(7-1-95)

107-13

SP1 G40

In addition to other requirements in this proposal with respect to clearing, erosion control, protection of environment, etc., comply with the following requirements:

- (A) Comply with the portions of these Special Requirements, entitled "Fire Plan," "Clearing Plan," and "Landscape and Erosion Control Plan." Note the fact that merchantable timber within Forest Service Property will become the property of the Contractor.
- (B) Comply with the following recommendations of the State Fish and Game Department and Forest Service for wildlife and fish management:
 - (1) Take all necessary precautions to avoid damage to fish habitat and exercise every reasonable precaution to prevent muddying or silting live streams.
 - (2) Do not deposit material removed from the roadway or channel changes in live streams or into the streams or stream channel where it would be washed away by high stream flows.
 - (3) Do not haul materials, including logs, brush, and debris, by fording live streams. Instead, provide temporary bridges or other structures for this purpose.
- (C) Dispose of waste material resulting from slides during construction and surplus material at locations approved by the Forest Supervisor. Submit a plan showing the proposed method of disposal at the time approval is requested.
- (D) Treat sections of existing road to be abandoned as a result of the proposed new construction, as designated by the Forest Supervisor, to restore them to their natural state. The necessary treatment will be determined during a joint review between the Forest Service and the State and may include ripping of roadbed, removal of drainage structure, and opening drainage channels. Plans and specifications as mutually deemed appropriate to accomplish the objective will become a part of this stipulation.
- (E) Permanently monument the right of way prior to completion of construction in accordance with State requirements for such right of way, but in any event the minimum requirements will be to place permanent monuments at the intersection of right of way with all property lines, section lines, and at intervals of not more than 1,000 feet along the right-of-way limits.
- (F) Re-establish or restore public land monuments disturbed or destroyed by construction, reconstruction, or maintenance according to instructions of the Bureau of Land

Management, Department of the Interior. Do not damage, destroy, or obliterate other land monuments and property corners or witness markers without the prior permission of the Regional Forester. Relocate or re-establish these land monuments, property corners, and witness markers in accordance with standards satisfactory to the Regional Forester.

Fire Protection Plan

During the period of construction, perform both independently and in cooperation with the Forest Service everything that is reasonable and practical to prevent and suppress forest fires on the easement area and in its immediate vicinity. Include provisions in all subcontracts for the construction of the road requiring subcontractors and their respective employees to do likewise. The contractors and subcontractors, shall conform to, but not be limited to, the following Fire Plan:

- (A) Take immediate independent or cooperative action to control and extinguish any fire, regardless of cause, within the easement area and its vicinity.
- (B) Maintain at readily available sites one or more boxes of firefighting tools to be furnished by the Forest Service for forest fire fighting purposes only.
- (C) Perform debris burning only in the center of the right of way, and only after a strip 20 feet wide around each pile is cleared to mineral soil.
- (D) Keep fires compact by throwing in the larger material as it burns. If piles are too close together or burn hot, light every second or third pile; allow these to cool down before firing the others. On slopes start burning at the top and work down. Confine fires to piles at all times.
- (E) Do not leave fires unattended.
- (F) Discontinue burning upon notification by the District Forest Ranger or his representative that fire danger is such that there is abnormal risk.
- (G) Whenever a fire escapes, notify the District Ranger immediately even if the fire is suppressed without Forest Service assistance.
- (H) The contractor or subcontractor responsible will bear the costs, including Forest Service direct costs and value of resources damages, incurred by the Forest Service in controlling and extinguishing any fire on or threatening National Forest lands which they or their employees caused with or without negligence in connection with construction operations.
- (I) Contact the District Ranger 24 hours in advance of burning.

Clearing Plan

Conform to the following clearing plan:

- (A) Dispose of unmerchantable materials including tops, branches, etc., by piling and burning as directed by the Forest Service or used in brush barriers. Alternate methods of disposal, including any of the following methods or combinations of methods (lop and scatter, chip, remove, pile only), shall be approved in advance by the Forest Service.

- (B) The maximum clearing and grubbing limits are to be as shown on the plans except that cutting of hazard trees outside these limits may be done with approval. Confine construction machinery within the clearing limits.

Landscape and Erosion Control Plan

The erosion control plan will be designed and implemented to prevent visible sediment, as defined by NC DEQ regulations, from reaching any defined stream channel.

Conform to, but not be limited to, the following Landscape and Erosion Control Plan.

- (A) Prevent visible sediment from entering any stream channel. If an erosion control practice must be sited in a channel, it shall stop further down-channel transport of visible sediment.
- (B) Bear responsibility for the prevention and control of soil erosion and gully on the right of way and lands adjacent thereto resulting from the construction or maintenance of the road. Revegetate with grass (not Love Grass) or herbaceous plants all ground where the soil has been exposed. Accomplish revegetation within 20 working days following final grading.
- (C) Round the ends of cut sections and the tops of back slopes.
- (D) Vegetate all front and back slopes by liming, fertilizing, mulching and seeding; including any waste area. Mulch critical areas if they are to be exposed greater than 5 working days of probable inclement weather during seasons when seeding is impracticable. Critical areas include all bare soils within 100 feet (slope distance) of perennial and intermittent streams. Mulch these as soon as practical and after final seeding.
- (E) Maintain all erosion control practices in a timely manner to prevent visible sediment from entering any stream channel, until such time that the final revegetation stabilizes the site and prevents erosion and off-site movement of sediment.

FUEL PRICE ADJUSTMENT:

(11-15-05) (Rev. 11-15-22)

109-8

SP1 G43

Revise the *2018 Standard Specifications* as follows:

Page 1-87, Article 109-8, Fuel Price Adjustments, add the following:

The base index price for DIESEL #2 FUEL is \$ **3.2066** per gallon. Where any of the following are included as pay items in the contract, they will be eligible for fuel price adjustment.

The pay items and the fuel factor used in calculating adjustments to be made will be as follows:

Description	Units	Fuel Usage Factor Diesel
Unclassified Excavation	Gal/CY	0.29
Borrow Excavation	Gal/CY	0.29
Class IV Subgrade Stabilization	Gal/Ton	0.55
Aggregate Base Course	Gal/Ton	0.55
Sub-Ballast	Gal/Ton	0.55
Erosion Control Stone	Gal/Ton	0.55
Rip Rap, Class _____	Gal/Ton	0.55

Asphalt Concrete Base Course, Type _____	Gal/Ton	0.90 or 2.90
Asphalt Concrete Intermediate Course, Type _____	Gal/Ton	0.90 or 2.90
Asphalt Concrete Surface Course, Type _____	Gal/Ton	0.90 or 2.90
Open-Graded Asphalt Friction Course	Gal/Ton	0.90 or 2.90
Permeable Asphalt Drainage Course, Type _____	Gal/Ton	0.90 or 2.90
Sand Asphalt Surface Course, Type _____	Gal/Ton	0.90 or 2.90
Ultra-thin Bonded Wearing Course	Gal/Ton	0.90 or 2.90
Aggregate for Cement Treated Base Course	Gal/Ton	0.55
Portland Cement for Cement Treated Base Course	Gal/Ton	0.55
> 11" Portland Cement Concrete Pavement	Gal/SY	0.327
Concrete Shoulders Adjacent to > 11" Pavement	Gal/SY	0.327
9" to 11" Portland Cement Concrete Pavement	Gal/SY	0.272
Concrete Shoulders Adjacent to 9" to 11" Pavement	Gal/SY	0.272
< 9" Portland Cement Concrete Pavement	Gal/SY	0.245
Concrete Shoulders Adjacent to < 9" Pavement	Gal/SY	0.245

For the asphalt items noted in the chart as eligible for fuel adjustments, the bidder may include the *Fuel Usage Factor Adjustment Form* with their bid submission if they elect to use the fuel usage factor. The *Fuel Usage Factor Adjustment Form* is found at the following link:

<https://connect.ncdot.gov/letting/LetCentral/Fuel%20Usage%20Factor%20Adjustment%20Form%20-%20Starting%20Nov%202022%20Lettings.pdf>

Select either 2.90 Gal/Ton fuel factor or 0.90 Gal/Ton fuel factor for each asphalt line item on the *Fuel Usage Factor Adjustment Form*. The selected fuel factor for each asphalt item will remain in effect for the duration of the contract.

Failure to complete the *Fuel Usage Factor Adjustment Form* will result in using 2.90 gallons per ton as the Fuel Usage Factor for Diesel for the asphalt items noted above. The contractor will not be permitted to change the Fuel Usage Factor after the bids are submitted.

SCHEDULE OF ESTIMATED COMPLETION PROGRESS:

(7-15-08) (Rev. 6-20-23)

108-2

SP1 G58

The Contractor's attention is directed to the Standard Special Provision entitled *Availability of Funds Termination of Contracts* included elsewhere in this proposal. The Department of Transportation's schedule of estimated completion progress for this project as required by that Standard Special Provision is as follows:

	<u>Fiscal Year</u>	<u>Progress (% of Dollar Value)</u>
2024	(7/01/23 - 6/30/24)	28% of Total Amount Bid
2025	(7/01/24 - 6/30/25)	72% of Total Amount Bid

The Contractor shall also furnish his own progress schedule in accordance with Article 108-2 of the *2018 Standard Specifications*. Any acceleration of the progress as shown by the Contractor's progress schedule over the progress as shown above shall be subject to the approval of the Engineer.

MINORITY BUSINESS ENTERPRISE AND WOMEN BUSINESS ENTERPRISE:

(10-16-07)(Rev. 8-17-21)

102-15(J)

SP1 G66

Description

The purpose of this Special Provision is to carry out the North Carolina Department of Transportation's policy of ensuring nondiscrimination in the award and administration of contracts financed in whole or in part with State funds.

Definitions

Additional MBE/WBE Subcontractors - Any MBE/WBE submitted at the time of bid that will not be used to meet the Combined MBE /WBE Goal. No submittal of a Letter of Intent is required.

Combined MBE/WBE Goal: A portion of the total contract, expressed as a percentage that is to be performed by committed MBE/WBE subcontractors.

Committed MBE/WBE Subcontractor - Any MBE/WBE submitted at the time of bid that is being used to meet the Combined MBE /WBE goal by submission of a Letter of Intent. Or any MBE or WBE used as a replacement for a previously committed MBE or WBE firm.

Contract Goal Requirement - The approved participation at time of award, but not greater than the advertised Combined MBE/WBE contract goal.

Goal Confirmation Letter - Written documentation from the Department to the bidder confirming the Contractor's approved, committed participation along with a listing of the committed MBE and WBE firms.

Manufacturer - A firm that operates or maintains a factory or establishment that produces on the premises, the materials or supplies obtained by the Contractor.

MBE Participation (Anticipated) - A portion of the total contract, expressed as a percentage that is anticipated to be performed by committed MBE subcontractor(s).

Minority Business Enterprise (MBE) - A firm certified as a Disadvantaged Minority-Owned Business Enterprise through the North Carolina Unified Certification Program.

Regular Dealer - A firm that owns, operates, or maintains a store, warehouse, or other establishment in which the materials or supplies required for the performance of the contract are bought, kept in stock, and regularly sold to the public in the usual course of business. A regular dealer engages in, as its principal business and in its own name, the purchase and sale or lease of the products in question. A regular dealer in such bulk items as steel, cement, gravel, stone, and petroleum products need not keep such products in stock, if it owns and operates distribution equipment for the products. Brokers and packagers are not regarded as manufacturers or regular dealers within the meaning of this section.

Replacement / Substitution – A full or partial reduction in the amount of work subcontracted to a committed (or an approved substitute) MBE/WBE firm.

North Carolina Unified Certification Program (NCUCP) - A program that provides comprehensive services and information to applicants for MBE/WBE certification. The MBE/WBE program follows the same regulations as the federal Disadvantaged Business Enterprise (DBE) program in accordance with 49 CFR Part 26.

United States Department of Transportation (USDOT) - Federal agency responsible for issuing regulations (49 CFR Part 26) and official guidance for the DBE program.

WBE Participation (Anticipated) - A portion of the total contract, expressed as a percentage, that is anticipated to be performed by committed WBE subcontractor(s).

Women Business Enterprise (WBE) - A firm certified as a Disadvantaged Women-Owned Business Enterprise through the North Carolina Unified Certification Program.

Forms and Websites Referenced in this Provision

Payment Tracking System - On-line system in which the Contractor enters the payments made to MBE and WBE subcontractors who have performed work on the project.
<https://apps.dot.state.nc.us/Vendor/PaymentTracking/>

DBE-IS Subcontractor Payment Information - Form for reporting the payments made to all MBE/WBE firms working on the project. This form is for paper bid projects only.
<https://connect.ncdot.gov/business/Turnpike/Documents/Form%20DBE-IS%20Subcontractor%20Payment%20Information.pdf>

RF-1 MBE/WBE Replacement Request Form - Form for replacing a committed MBE or WBE.
<http://connect.ncdot.gov/projects/construction/Construction%20Forms/DBE%20MBE%20WBE%20Replacement%20Request%20Form.pdf>

SAF Subcontract Approval Form - Form required for approval to sublet the contract.
<http://connect.ncdot.gov/projects/construction/Construction%20Forms/Subcontract%20Approval%20Form%20Rev.%202012.zip>

JC-1 Joint Check Notification Form - Form and procedures for joint check notification. The form acts as a written joint check agreement among the parties providing full and prompt disclosure of the expected use of joint checks.
<http://connect.ncdot.gov/projects/construction/Construction%20Forms/Joint%20Check%20Notification%20Form.pdf>

Letter of Intent - Form signed by the Contractor and the MBE/WBE subcontractor, manufacturer or regular dealer that affirms that a portion of said contract is going to be performed by the signed MBE/WBE for the estimated amount (based on quantities and unit prices) listed at the time of bid.
<http://connect.ncdot.gov/letting/LetCentral/Letter%20of%20Intent%20to%20Perform%20as%20a%20Subcontractor.pdf>

Listing of MBE and WBE Subcontractors Form - Form for entering MBE/WBE subcontractors on a project that will meet the Combined MBE/WBE goal. This form is for paper bids only.
[http://connect.ncdot.gov/municipalities/Bid%20Proposals%20for%20LGA%20Content/09%20MBE-WBE%20Subcontractors%20\(State\).docx](http://connect.ncdot.gov/municipalities/Bid%20Proposals%20for%20LGA%20Content/09%20MBE-WBE%20Subcontractors%20(State).docx)

Subcontractor Quote Comparison Sheet - Spreadsheet for showing all subcontractor quotes in the work areas where MBEs and WBEs quoted on the project. This sheet is submitted with good faith effort packages.
<http://connect.ncdot.gov/business/SmallBusiness/Documents/DBE%20Subcontractor%20Quote%20Comparison%20Example.xls>

Combined MBE/WBE Goal

The Combined MBE/WBE Goal for this project is **1.0 %**

The Combined Goal was established utilizing the following anticipated participation for Minority Business Enterprises and Women Business Enterprises:

(A) Minority Business Enterprises **0.0 %**

- (1) *If the anticipated MBE participation is more than zero*, the Contractor shall exercise all necessary and reasonable steps to ensure that MBEs participate in at least the percent of the contract as set forth above.
- (2) *If the anticipated MBE participation is zero*, the Contractor shall make an effort to recruit and use MBEs during the performance of the contract. Any MBE participation obtained shall be reported to the Department.

(B) Women Business Enterprises **1.0 %**

- (1) *If the anticipated WBE participation is more than zero*, the Contractor shall exercise all necessary and reasonable steps to ensure that WBEs participate in at least the percent of the contract as set forth above.
- (2) *If the anticipated WBE participation is zero*, the Contractor shall make an effort to recruit and use WBEs during the performance of the contract. Any WBE participation obtained shall be reported to the Department.

The Bidder is required to submit only participation to meet the Combined MBE/WBE Goal. The Combined Goal may be met by submitting all MBE participation, all WBE participation, or a combination of MBE and WBE participation.

Directory of Transportation Firms (Directory)

Real-time information is available about firms doing business with the Department and firms that are certified through NCUCP in the Directory of Transportation Firms. Only firms identified in the Directory as MBE and WBE certified shall be used to meet the Combined MBE/WBE Goal. The Directory can be found at the following link.

<https://www.ebs.nc.gov/VendorDirectory/default.html>

The listing of an individual firm in the directory shall not be construed as an endorsement of the firm's capability to perform certain work.

Listing of MBE/WBE Subcontractors

At the time of bid, bidders shall submit all MBE and WBE participation that they anticipate to use during the life of the contract. Only those identified to meet the Combined MBE/WBE Goal will be considered committed, even though the listing shall include both committed MBE/WBE subcontractors and additional MBE/WBE subcontractors. Any additional MBE/WBE subcontractor participation above the goal will follow the banking guidelines found elsewhere in this provision. All other additional MBE/WBE subcontractor participation submitted at the time of bid will be used toward the Department's overall race-neutral goals. Only those firms with current MBE and WBE certification at the time of bid opening will be acceptable for listing in the

bidder's submittal of MBE and WBE participation. The Contractor shall indicate the following required information:

(A) Electronic Bids

Bidders shall submit a listing of MBE and WBE participation in the appropriate section of the electronic submittal file.

- (1) Submit the names and addresses of MBE and WBE firms identified to participate in the contract. If the bidder uses the updated listing of MBE and WBE firms shown in the electronic submittal file, the bidder may use the dropdown menu to access the name and address of the firms.
- (2) Submit the contract line numbers of work to be performed by each MBE and WBE firm. When no figures or firms are entered, the bidder will be considered to have no MBE or WBE participation.
- (3) The bidder shall be responsible for ensuring that the MBE and WBE are certified at the time of bid by checking the Directory of Transportation Firms. If the firm is not certified at the time of the bid-letting, that MBE's or WBE's participation will not count towards achieving the Combined MBE/WBE goal.

(B) Paper Bids

- (1) *If the Combined MBE/WBE Goal is more than zero,*
 - (a) Bidders, at the time the bid proposal is submitted, shall submit a listing of MBE/WBE participation, including the names and addresses on *Listing of MBE and WBE Subcontractors* contained elsewhere in the contract documents in order for the bid to be considered responsive. Bidders shall indicate the total dollar value of the MBE and WBE participation for the contract.
 - (b) If bidders have no MBE or WBE participation, they shall indicate this on the *Listing of MBE and WBE Subcontractors* by entering the word "None" or the number "0." This form shall be completed in its entirety. **Blank forms will not be deemed to represent zero participation.** Bids submitted that do not have MBE and WBE participation indicated on the appropriate form will not be read publicly during the opening of bids. The Department will not consider these bids for award and the proposal will be rejected.
 - (c) The bidder shall be responsible for ensuring that the MBE/WBE is certified at the time of bid by checking the Directory of Transportation Firms. If the firm is not certified at the time of the bid-letting, that MBE's or WBE's participation will not count towards achieving the Combined MBE/WBE Goal.
- (2) *If the Combined MBE/WBE Goal is zero,* entries on the *Listing of MBE and WBE Subcontractors* are not required for the zero goal, however any MBE or WBE

participation that is achieved during the project shall be reported in accordance with requirements contained elsewhere in the special provision.

MBE or WBE Prime Contractor

When a certified MBE or WBE firm bids on a contract that contains a Combined MBE/WBE goal, the firm is responsible for meeting the goal or making good faith efforts to meet the goal, just like any other bidder. In most cases, a MBE or WBE bidder on a contract will meet the Combined MBE/WBE Goal by virtue of the work it performs on the contract with its own forces. However, all the work that is performed by the MBE or WBE bidder and any other similarly certified subcontractors will count toward the goal. The MBE or WBE bidder shall list itself along with any MBE or WBE subcontractors, if any, in order to receive credit toward the goal.

MBE/WBE prime contractors shall also follow Sections A and B listed under *Listing of MBE/WBE Subcontractor* just as a non-MBE/WBE bidder would.

Written Documentation – Letter of Intent

The bidder shall submit written documentation for each MBE/WBE that will be used to meet the Combined MBE/WBE Goal of the contract, indicating the bidder's commitment to use the MBE/WBE in the contract. This documentation shall be submitted on the Department's form titled *Letter of Intent*.

The documentation shall be received in the office of the State Contractor Utilization Engineer or at DBE@ncdot.gov no later than 10:00 a.m. of the sixth calendar day following opening of bids, unless the sixth day falls on an official state holiday. In that situation, it is due in the office of the State Contractor Utilization Engineer no later than 10:00 a.m. on the next official state business day.

If the bidder fails to submit the Letter of Intent from each committed MBE and WBE to be used toward the Combined MBE/WBE Goal, or if the form is incomplete (i.e. both signatures are not present), the MBE/WBE participation will not count toward meeting the Combined MBE/WBE Goal. If the lack of this participation drops the commitment below the Combined MBE/WBE Goal, the Contractor shall submit evidence of good faith efforts for the goal, completed in its entirety, to the State Contractor Utilization Engineer or DBE@ncdot.gov no later than 10:00 a.m. on the eighth calendar day following opening of bids, unless the eighth day falls on an official state holiday. In that situation, it is due in the office of the State Contractor Utilization Engineer no later than 10:00 a.m. on the next official state business day.

Banking MBE/WBE Credit

If the bid of the lowest responsive bidder exceeds \$500,000 and if the committed MBE/WBE participation submitted exceeds the algebraic sum of the Combined MBE /WBE Goal by \$1,000 or more, the excess will be placed on deposit by the Department for future use by the bidder. Separate accounts will be maintained for MBE and WBE participation and these may accumulate for a period not to exceed 24 months.

When the apparent lowest responsive bidder fails to submit sufficient participation by MBE and WBE firms to meet the advertised goal, as part of the good faith effort, the Department will consider allowing the bidder to withdraw funds to meet the Combined MBE/WBE Goal as long as there are adequate funds available from the bidder's MBE and WBE bank accounts.

Submission of Good Faith Effort

If the bidder fails to meet or exceed the Combined MBE/WBE Goal, the apparent lowest responsive bidder shall submit to the Department documentation of adequate good faith efforts made to reach that specific goal.

A hard copy and an electronic copy of this information shall be received in the office of the State Contractor Utilization Engineer or at DBE@ncdot.gov no later than 10:00 a.m. on the sixth calendar day following opening of bids unless the sixth day falls on an official state holiday. In that situation, it would be due in the office of the State Contractor Utilization Engineer no later than 10:00 a.m. on the next official state business day. If the contractor cannot send the information electronically, then one complete set and 5 copies of this information shall be received under the same time constraints above.

Note: Where the information submitted includes repetitious solicitation letters, it will be acceptable to submit a representative letter along with a distribution list of the firms that were solicited. Documentation of MBE/WBE quotations shall be a part of the good faith effort submittal. This documentation may include written subcontractor quotations, telephone log notations of verbal quotations, or other types of quotation documentation.

Consideration of Good Faith Effort for Projects with a Combined MBE/WBE Goal More Than Zero

Adequate good faith efforts mean that the bidder took all necessary and reasonable steps to achieve the goal which, by their scope, intensity, and appropriateness, could reasonably be expected to obtain sufficient MBE/WBE participation. Adequate good faith efforts also mean that the bidder actively and aggressively sought MBE/WBE participation. Mere *pro forma* efforts are not considered good faith efforts.

The Department will consider the quality, quantity, and intensity of the different kinds of efforts a bidder has made. Listed below are examples of the types of actions a bidder will take in making a good faith effort to meet the goals and are not intended to be exclusive or exhaustive, nor is it intended to be a mandatory checklist.

- (A) Soliciting through all reasonable and available means (e.g. attendance at pre-bid meetings, advertising, written notices, use of verifiable electronic means through the use of the NCDOT Directory of Transportation Firms) the interest of all certified MBEs/WBEs that are also prequalified subcontractors. The bidder must solicit this interest within at least 10 days prior to bid opening to allow the MBEs/WBEs to respond to the solicitation. Solicitation shall provide the opportunity to MBEs/WBEs within the Division and surrounding Divisions where the project is located. The bidder must determine with certainty if the MBEs/WBEs are interested by taking appropriate steps to follow up initial solicitations.

- (B) Selecting portions of the work to be performed by MBEs/WBEs in order to increase the likelihood that the Combined MBE/WBE Goal will be achieved.
- (1) Where appropriate, break out contract work items into economically feasible units to facilitate MBE/WBE participation, even when the prime contractor might otherwise prefer to perform these work items with its own forces.
 - (2) Negotiate with subcontractors to assume part of the responsibility to meet the advertised goal when the work to be sublet includes potential for MBE/WBE participation (2nd and 3rd tier subcontractors).
- (C) Providing interested certified MBEs/WBEs that are also prequalified subcontractors with adequate information about the plans, specifications, and requirements of the contract in a timely manner to assist them in responding to a solicitation.
- (D) (1) Negotiating in good faith with interested MBEs/WBEs. It is the bidder's responsibility to make a portion of the work available to MBE/WBE subcontractors and suppliers and to select those portions of the work or material needs consistent with the available MBE/WBE subcontractors and suppliers, so as to facilitate MBE/WBE participation. Evidence of such negotiation includes the names, addresses, and telephone numbers of MBEs/WBEs that were considered; a description of the information provided regarding the plans and specifications for the work selected for subcontracting; and evidence as to why additional agreements could not be reached for MBEs/WBEs to perform the work.
- (2) A bidder using good business judgment would consider a number of factors in negotiating with subcontractors, including MBE/WBE subcontractors, and would take a firm's price and capabilities as well as the advertised goal into consideration. However, the fact that there may be some additional costs involved in finding and using MBEs/WBEs is not in itself sufficient reason for a bidder's failure to meet the contract goal, as long as such costs are reasonable. Also, the ability or desire of a prime contractor to perform the work of a contract with its own organization does not relieve the bidder of the responsibility to make good faith efforts. Bidding contractors are not, however, required to accept higher quotes from MBEs/WBEs if the price difference is excessive or unreasonable.
- (E) Not rejecting MBEs/WBEs as being unqualified without sound reasons based on a thorough investigation of their capabilities. The bidder's standing within its industry, membership in specific groups, organizations, or associates and political or social affiliations (for example, union vs. non-union employee status) are not legitimate causes for the rejection or non-solicitation of bids in the bidder's efforts to meet the project goal.
- (F) Making efforts to assist interested MBEs/WBEs in obtaining bonding, lines of credit, or insurance as required by the recipient or bidder.
- (G) Making efforts to assist interested MBEs/WBEs in obtaining necessary equipment, supplies, materials, or related assistance or services.

- (H) Effectively using the services of available minority/women community organizations; minority/women contractors' groups; Federal, State, and local minority/women business assistance offices; and other organizations as allowed on a case-by-case basis to provide assistance in the recruitment and placement of MBEs/WBEs. Contact within 7 days from the bid opening the Business Opportunity and Work Force Development Unit at BOWD@ncdot.gov to give notification of the bidder's inability to get MBE or WBE quotes.
- (I) Any other evidence that the bidder submits which shows that the bidder has made reasonable good faith efforts to meet the advertised goal.

In addition, the Department may take into account the following:

- (1) Whether the bidder's documentation reflects a clear and realistic plan for achieving the Combined MBE/WBE Goal.
- (2) The bidders' past performance in meeting the contract goal.
- (3) The performance of other bidders in meeting the advertised goal. For example, when the apparent successful bidder fails to meet the goal, but others meet it, you may reasonably raise the question of whether, with additional reasonable efforts the apparent successful bidder could have met the goal. If the apparent successful bidder fails to meet the advertised goal, but meets or exceeds the average MBE and WBE participation obtained by other bidders, the Department may view this, in conjunction with other factors, as evidence of the apparent successful bidder having made a good faith effort.

If the Department does not award the contract to the apparent lowest responsive bidder, the Department reserves the right to award the contract to the next lowest responsive bidder that can satisfy to the Department that the Combined MBE/WBE Goal can be met or that an adequate good faith effort has been made to meet the advertised goal.

Non-Good Faith Appeal

The State Prequalification Engineer will notify the contractor verbally and in writing of non-good faith. A contractor may appeal a determination of non-good faith made by the Goal Compliance Committee. If a contractor wishes to appeal the determination made by the Committee, they shall provide written notification to the State Prequalification Engineer or at DBE@ncdot.gov. The appeal shall be made within 2 business days of notification of the determination of non-good faith.

Counting MBE/WBE Participation Toward Meeting the Combined MBE/WBE Goal

- (A) Participation

The total dollar value of the participation by a committed MBE/WBE will be counted toward the contract goal requirements. The total dollar value of participation by

a committed MBE/WBE will be based upon the value of work actually performed by the MBE/WBE and the actual payments to MBE/WBE firms by the Contractor.

(B) Joint Checks

Prior notification of joint check use shall be required when counting MBE/WBE participation for services or purchases that involves the use of a joint check. Notification shall be through submission of Form JC-1 (*Joint Check Notification Form*) and the use of joint checks shall be in accordance with the Department's Joint Check Procedures.

(C) Subcontracts (Non-Trucking)

A MBE/WBE may enter into subcontracts. Work that a MBE subcontracts to another MBE firm may be counted toward the anticipated MBE participation. The same holds true for work that a WBE subcontracts to another WBE firm. Work that a MBE/WBE subcontracts to a non-MBE/WBE firm does not count toward the contract goal requirement. It should be noted that every effort shall be made by MBE and WBE contractors to subcontract to the same certification (i.e., MBEs to MBEs and WBEs to WBEs), in order to fulfill the MBE or WBE participation breakdown. This, however, may not always be possible due to the limitation of firms in the area. If the MBE or WBE firm shows a good faith effort has been made to reach out to similarly certified firms and there is no interest or availability, and they can get assistance from other certified firms, the Engineer will not hold the prime responsible for meeting the individual MBE or WBE breakdown. If a MBE or WBE contractor or subcontractor subcontracts a significantly greater portion of the work of the contract than would be expected on the basis of standard industry practices, it shall be presumed that the MBE or WBE is not performing a commercially useful function.

(D) Joint Venture

When a MBE or WBE performs as a participant in a joint venture, the Contractor may count toward its contract goal requirement a portion of the total value of participation with the MBE or WBE in the joint venture, that portion of the total dollar value being a distinct clearly defined portion of work that the MBE or WBE performs with its forces.

(E) Suppliers

A contractor may count toward its MBE/ WBE requirement 60 percent of its expenditures for materials and supplies required to complete the contract and obtained from a MBE or WBE regular dealer and 100 percent of such expenditures from a MBE or WBE manufacturer.

(F) Manufacturers and Regular Dealers

A contractor may count toward its MBE/ WBE requirement the following expenditures to MBE/WBE firms that are not manufacturers or regular dealers:

- (1) The fees or commissions charged by a MBE/WBE firm for providing a *bona fide* service, such as professional, technical, consultant, or managerial services, or for providing bonds or insurance specifically required for the performance of a DOT-assisted contract, provided the fees or commissions are determined to be reasonable and not excessive as compared with fees and commissions customarily allowed for similar services.
- (2) With respect to materials or supplies purchased from a MBE/WBE, which is neither a manufacturer nor a regular dealer, count the entire amount of fees or commissions charged for assistance in the procurement of the materials and supplies, or fees or transportation charges for the delivery of materials or supplies required on a job site (but not the cost of the materials and supplies themselves), provided the fees are determined to be reasonable and not excessive as compared with fees customarily allowed for similar services.

Commercially Useful Function

(A) MBE/WBE Utilization

The Contractor may count toward its contract goal requirement only expenditures to MBEs and WBEs that perform a commercially useful function in the work of a contract. A MBE/WBE performs a commercially useful function when it is responsible for execution of the work of the contract and is carrying out its responsibilities by actually performing, managing, and supervising the work involved. To perform a commercially useful function, the MBE/WBE shall also be responsible with respect to materials and supplies used on the contract, for negotiating price, determining quality and quantity, ordering the material and installing (where applicable) and paying for the material itself. To determine whether a MBE/WBE is performing a commercially useful function, the Department will evaluate the amount of work subcontracted, industry practices, whether the amount the firm is to be paid under the contract is commensurate with the work it is actually performing and the MBE/WBE credit claimed for its performance of the work, and any other relevant factors. If it is determined that a MBE or WBE is not performing a Commercially Useful Function, the contractor may present evidence to rebut this presumption to the Department.

(B) MBE/WBE Utilization in Trucking

The following factors will be used to determine if a MBE or WBE trucking firm is performing a commercially useful function:

- (1) The MBE/WBE shall be responsible for the management and supervision of the entire trucking operation for which it is responsible on a particular contract, and

there shall not be a contrived arrangement for the purpose of meeting the Combined MBE/WBE Goal.

- (2) The MBE/WBE shall itself own and operate at least one fully licensed, insured, and operational truck used on the contract.
- (3) The MBE/WBE receives credit for the total value of the transportation services it provides on the contract using trucks it owns, insures, and operates using drivers it employs.
- (4) The MBE may subcontract the work to another MBE firm, including an owner-operator who is certified as a MBE. The same holds true that a WBE may subcontract the work to another WBE firm, including an owner-operator who is certified as a WBE. When this occurs, the MBE or WBE who subcontracts work receives credit for the total value of the transportation services the subcontracted MBE or WBE provides on the contract. It should be noted that every effort shall be made by MBE and WBE contractors to subcontract to the same certification (i.e., MBEs to MBEs and WBEs to WBEs), in order to fulfill the participation breakdown. This, however, may not always be possible due to the limitation of firms in the area. If the MBE or WBE firm shows a good faith effort has been made to reach out to similarly certified transportation service providers and there is no interest or availability, and they can get assistance from other certified providers, the Engineer will not hold the prime responsible for meeting the individual MBE or WBE participation breakdown.
- (5) The MBE/WBE may also subcontract the work to a non-MBE/WBE firm, including from an owner-operator. The MBE/WBE who subcontracts the work to a non-MBE/WBE is entitled to credit for the total value of transportation services provided by the non-MBE/WBE subcontractor not to exceed the value of transportation services provided by MBE/WBE-owned trucks on the contract. Additional participation by non-MBE/WBE subcontractors receives credit only for the fee or commission it receives as a result of the subcontract arrangement. The value of services performed under subcontract agreements between the MBE/WBE and the Contractor will not count towards the MBE/WBE contract requirement.
- (6) A MBE/WBE may lease truck(s) from an established equipment leasing business open to the general public. The lease must indicate that the MBE/WBE has exclusive use of and control over the truck. This requirement does not preclude the leased truck from working for others during the term of the lease with the consent of the MBE/WBE, so long as the lease gives the MBE/WBE absolute priority for use of the leased truck. This type of lease may count toward the MBE/WBE's credit as long as the driver is under the MBE/WBE's payroll.
- (7) Subcontracted/leased trucks shall display clearly on the dashboard the name of the MBE/WBE that they are subcontracted/leased to and their own company name if it is not identified on the truck itself. Magnetic door signs are not permitted.

MBE/WBE Replacement

When a Contractor has relied on a commitment to a MBE or WBE subcontractor (or an approved substitute MBE or WBE subcontractor) to meet all or part of a contract goal requirement, the contractor shall not terminate the MBE/WBE subcontractor for convenience. This includes, but is not limited to, instances in which the Contractor seeks to perform the work of the terminated subcontractor with another MBE/WBE subcontractor, a non-MBE/WBE subcontractor, or with the Contractor's own forces or those of an affiliate.

The Contractor must give notice in writing both by certified mail and email to the MBE/WBE subcontractor, with a copy to the Engineer of its intent to request to terminate and/or substitute, and the reason for the request. The Contractor must give the MBE/WBE subcontractor five (5) business days to respond to the Contractor's Notice of Intent to Request Termination and/or Substitution. If the MBE/WBE subcontractor objects to the intended termination/substitution, the MBE/WBE, within five (5) business days must advise the Contractor and the Department of the reasons why the action should not be approved. The five-day notice period shall begin on the next business day after written notice is provided to the MBE/WBE subcontractor.

A committed MBE/WBE subcontractor may only be terminated after receiving the Department's written approval based upon a finding of good cause for the proposed termination and/or substitution. For purposes of this section, good cause shall include the following circumstances:

- (a) The listed MBE/WBE subcontractor fails or refuses to execute a written contract;
- (b) The listed MBE/WBE subcontractor fails or refuses to perform the work of its subcontract in a way consistent with normal industry standards. Provided, however, that good cause does not exist if the failure or refusal of the MBE/WBE subcontractor to perform its work on the subcontract results from the bad faith or discriminatory action of the prime contractor;
- (c) The listed MBE/WBE subcontractor fails or refuses to meet the prime contractor's reasonable, nondiscriminatory bond requirements;
- (d) The listed MBE/WBE subcontractor becomes bankrupt, insolvent, or exhibits credit unworthiness;
- (e) The listed MBE/WBE subcontractor is ineligible to work on public works projects because of suspension and debarment proceedings pursuant to 2 CFR Parts 180, 215 and 1,200 or applicable state law;
- (f) The listed MBE/WBE subcontractor is not a responsible contractor;
- (g) The listed MBE/WBE voluntarily withdraws from the project and provides written notice of withdrawal;
- (h) The listed MBE/WBE is ineligible to receive MBE/WBE credit for the type of work required;
- (i) A MBE/WBE owner dies or becomes disabled with the result that the listed MBE/WBE contractor is unable to complete its work on the contract;
- (j) Other documented good cause that compels the termination of the MBE/WBE subcontractor. Provided, that good cause does not exist if the prime contractor seeks to terminate a MBE/WBE it relied upon to obtain the contract so that the prime contractor can self-perform the work for which the MBE/WBE contractor was engaged or so that the prime contractor can substitute another MBE/WBE or non-MBE/WBE contractor after contract award.

The Contractor shall comply with the following for replacement of a committed MBE/WBE:

(A) Performance Related Replacement

When a committed MBE/WBE is terminated for good cause as stated above, an additional MBE/WBE that was submitted at the time of bid may be used to fulfill the MBE/WBE commitment to meet the Combined MBE/WBE Goal. A good faith effort will only be required for removing a committed MBE/WBE if there were no additional MBE/WBEs submitted at the time of bid to cover the same amount of work as the MBE/WBE that was terminated.

If a replacement MBE/WBE is not found that can perform at least the same amount of work as the terminated MBE/WBE, the Contractor shall submit a good faith effort documenting the steps taken. Such documentation shall include, but not be limited to, the following:

- (1) Copies of written notification to MBE/WBEs that their interest is solicited in contracting the work defaulted by the previous MBE/WBE or in subcontracting other items of work in the contract.
- (2) Efforts to negotiate with MBE/WBEs for specific subbids including, at a minimum:
 - (a) The names, addresses, and telephone numbers of MBE/WBEs who were contacted.
 - (b) A description of the information provided to MBE/WBEs regarding the plans and specifications for portions of the work to be performed.
- (3) A list of reasons why MBE/WBE quotes were not accepted.
- (4) Efforts made to assist the MBE/WBEs contacted, if needed, in obtaining bonding or insurance required by the Contractor.

(B) Decertification Replacement

- (1) When a committed MBE/WBE is decertified by the Department after the SAF (*Subcontract Approval Form*) has been received by the Department, the Department will not require the Contractor to solicit replacement MBE/WBE participation equal to the remaining work to be performed by the decertified firm. The participation equal to the remaining work performed by the decertified firm will count toward the contract goal requirement.
- (2) When a committed MBE/WBE is decertified prior to the Department receiving the SAF (*Subcontract Approval Form*) for the named MBE/WBE firm, the Contractor shall take all necessary and reasonable steps to replace the MBE/WBE subcontractor with another MBE/WBE subcontractor to perform at least the same amount of work to meet the Combined MBE/WBE goal requirement. If a MBE/WBE firm is not found to do the same amount of work, a good faith effort must be submitted to NCDOT (see A herein for required documentation).

- (3) Exception: If the MBE/WBE's ineligibility is caused solely by its having exceeded the size standard during the performance of the contract, the Department will not require the Contractor to solicit replacement MBE/WBE participation equal to the remaining work to be performed by the decertified firm. The participation equal to the remaining work performed by the decertified firm will count toward the contract goal requirement and overall goal.

All requests for replacement of a committed MBE/WBE firm shall be submitted to the Engineer for approval on Form RF-1 (*DBE Replacement Request*). If the Contractor fails to follow this procedure, the Contractor may be disqualified from further bidding for a period of up to 6 months.

Changes in the Work

When the Engineer makes changes that result in the reduction or elimination of work to be performed by a committed MBE/WBE, the Contractor will not be required to seek additional participation. When the Engineer makes changes that result in additional work to be performed by a MBE/WBE based upon the Contractor's commitment, the MBE/WBE shall participate in additional work to the same extent as the MBE/WBE participated in the original contract work.

When the Engineer makes changes that result in extra work, which has more than a minimal impact on the contract amount, the Contractor shall seek additional participation by MBEs/WBEs unless otherwise approved by the Engineer.

When the Engineer makes changes that result in an alteration of plans or details of construction, and a portion or all of the work had been expected to be performed by a committed MBE/WBE, the Contractor shall seek participation by MBEs/WBEs unless otherwise approved by the Engineer.

When the Contractor requests changes in the work that result in the reduction or elimination of work that the Contractor committed to be performed by a MBE/WBE, the Contractor shall seek additional participation by MBEs/WBEs equal to the reduced MBE/WBE participation caused by the changes.

Reports and Documentation

A SAF (*Subcontract Approval Form*) shall be submitted for all work which is to be performed by a MBE/WBE subcontractor. The Department reserves the right to require copies of actual subcontract agreements involving MBE/WBE subcontractors.

When using transportation services to meet the contract commitment, the Contractor shall submit a proposed trucking plan in addition to the SAF. The plan shall be submitted prior to beginning construction on the project. The plan shall include the names of all trucking firms proposed for use, their certification type(s), the number of trucks owned by the firm, as well as the individual truck identification numbers, and the line item(s) being performed.

Within 30 calendar days of entering into an agreement with a MBE/WBE for materials, supplies or services, not otherwise documented by the SAF as specified above, the Contractor shall furnish

the Engineer a copy of the agreement. The documentation shall also indicate the percentage (60% or 100%) of expenditures claimed for MBE/WBE credit.

Reporting Minority and Women Business Enterprise Participation

The Contractor shall provide the Engineer with an accounting of payments made to all MBE/WBE firms, including material suppliers and contractors at all levels (prime, subcontractor, or second tier subcontractor). This accounting shall be furnished to the Engineer for any given month by the end of the following month. Failure to submit this information accordingly may result in the following action:

- (A) Withholding of money due in the next partial pay estimate; or
- (B) Removal of an approved contractor from the prequalified bidders' list or the removal of other entities from the approved subcontractors list.

While each contractor (prime, subcontractor, 2nd tier subcontractor) is responsible for accurate accounting of payments to MBEs/WBEs, it shall be the prime contractor's responsibility to report all monthly and final payment information in the correct reporting manner.

Failure on the part of the Contractor to submit the required information in the time frame specified may result in the disqualification of that contractor and any affiliate companies from further bidding until the required information is submitted.

Failure on the part of any subcontractor to submit the required information in the time frame specified may result in the disqualification of that contractor and any affiliate companies from being approved for work on future DOT projects until the required information is submitted.

Contractors reporting transportation services provided by non-MBE/WBE lessees shall evaluate the value of services provided during the month of the reporting period only.

At any time, the Engineer can request written verification of subcontractor payments.

The Contractor shall report the accounting of payments through the Department's Payment Tracking System.

Failure to Meet Contract Requirements

Failure to meet contract requirements in accordance with Subarticle 102-15(J) of the *2018 Standard Specifications* may be cause to disqualify the Contractor.

RESTRICTIONS ON ITS EQUIPMENT AND SERVICES:

(11-17-20)

SP01 G090

All telecommunications, video or other ITS equipment or services installed or utilized on this project must be in conformance with UNIFORM ADMINISTRATIVE REQUIREMENTS, COST PRINCIPLES, AND AUDIT REQUIREMENTS FOR FEDERAL AWARDS **2 CFR, § 200.216** **Prohibition on certain telecommunications and video surveillance services or equipment.**

USE OF UNMANNED AIRCRAFT SYSTEM (UAS):

(8-20-19)

SP1 G092

The Contractor shall adhere to all Federal, State and Local regulations and guidelines for the use of Unmanned Aircraft Systems (UAS). This includes but is not limited to US 14 CFR Part 107 *Small UAS Rule*, NC GS 15A-300.2 *Regulation of launch and recovery sites*, NC GS 63-95 *Training required for the operation of unmanned aircraft systems*, NC GS 63-96 *Permit required for commercial operation of unmanned aircraft system*, and NCDOT UAS Policy. The required operator certifications include possessing a current Federal Aviation Administration (FAA) Remote Pilot Certificate, a NC UAS Operator Permit as well as operating a UAS registered with the FAA.

Prior to beginning operations, the Contractor shall complete the NCDOT UAS – Flight Operation Approval Form and submit it to the Engineer for approval. All UAS operations shall be approved by the Engineer prior to beginning the operations.

All contractors or subcontractors operating UAS shall have UAS specific general liability insurance to cover all operations under this contract.

The use of UAS is at the Contractor's discretion. No measurement or payment will be made for the use of UAS. In the event that the Department directs the Contractor to utilize UAS, payment will be in accordance with Article 104-7 Extra Work.

EQUIPMENT IDLING GUIDELINES:

(1-19-21)

107

SP1 G096

Exercise reduced fuel consumption and reduced equipment emissions during the construction of all work associated with this contract. Employees engaged in the construction of this project should turn off vehicles when stopped for more than thirty (30) minutes and off-highway equipment should idle no longer than fifteen (15) consecutive minutes.

These guidelines for turning off vehicles and equipment when idling do not apply to:

1. Idling when queuing.
2. Idling to verify the vehicle is in safe operating condition.
3. Idling for testing, servicing, repairing or diagnostic purposes.

OUTSOURCING OUTSIDE THE USA:

(9-21-04) (Rev. 5-16-06)

SP1 G150

All work on consultant contracts, services contracts, and construction contracts shall be performed in the United States of America. No work shall be outsourced outside of the United States of America.

Outsourcing for the purpose of this provision is defined as the practice of subcontracting labor, work, services, staffing, or personnel to entities located outside of the United States.

The North Carolina Secretary of Transportation shall approve exceptions to this provision in writing.

NOTE TO CONTRACTOR:

Any concrete waste water shall be disposed of in accordance with the Department of Environmental Quality General Permit NCG01.

PORTABLE CONCRETE BARRIER - (Partial Payments for Materials):

(7-1-95) (Rev. 8-16-11)

1170-4

SP1 G121

When so authorized by the Engineer, partial materials payments will be made up to 95 percent of the delivered cost of portable concrete barrier, provided that these materials have been delivered on the project and stored in an acceptable manner, and further provided the documents listed in Subarticle 109-5(C) of the *2018 Standard Specifications* have been furnished to the Engineer.

The provisions of Subarticle 109-5(B) of the *2018 Standard Specifications* will apply to the portable concrete barrier.

STATE OF NORTH CAROLINA
DIVISION OF HIGHWAYS

TRANSPORTATION MANAGEMENT PLAN
CHEROKEE COUNTY

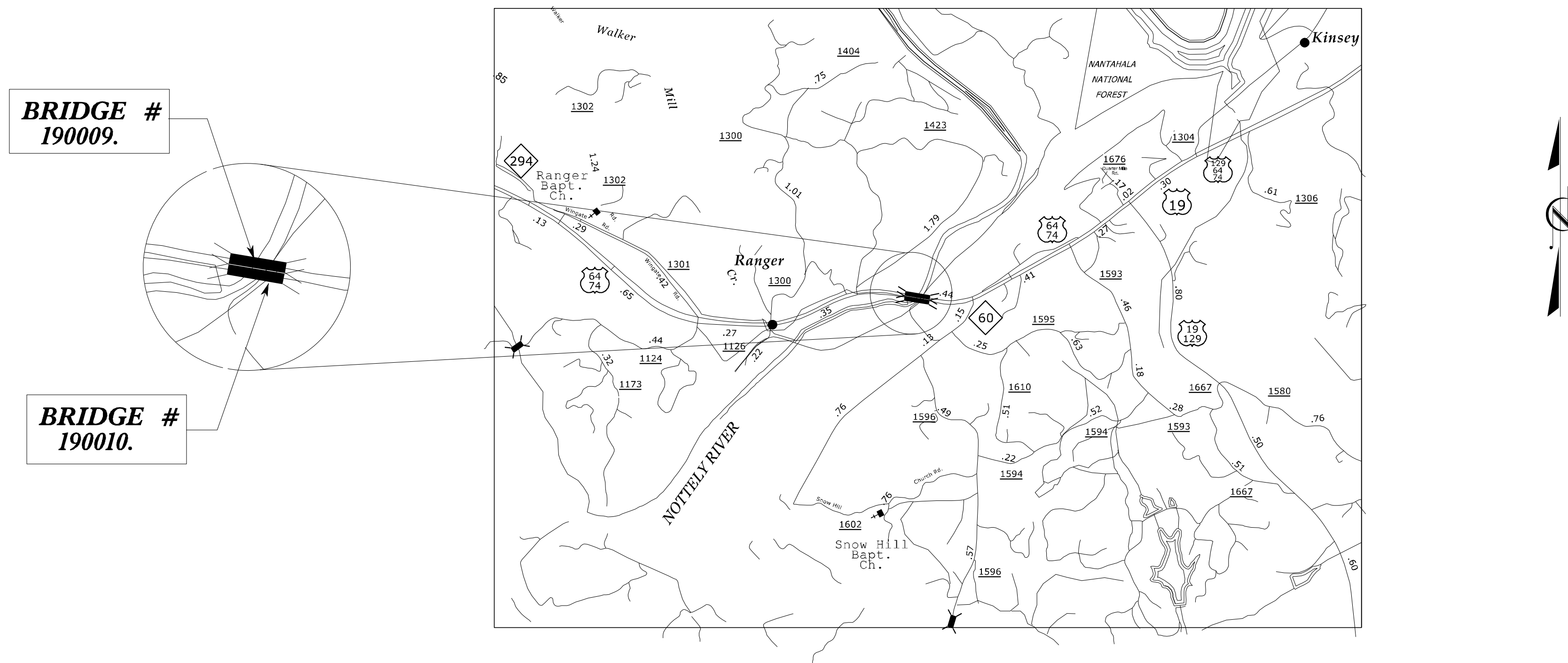
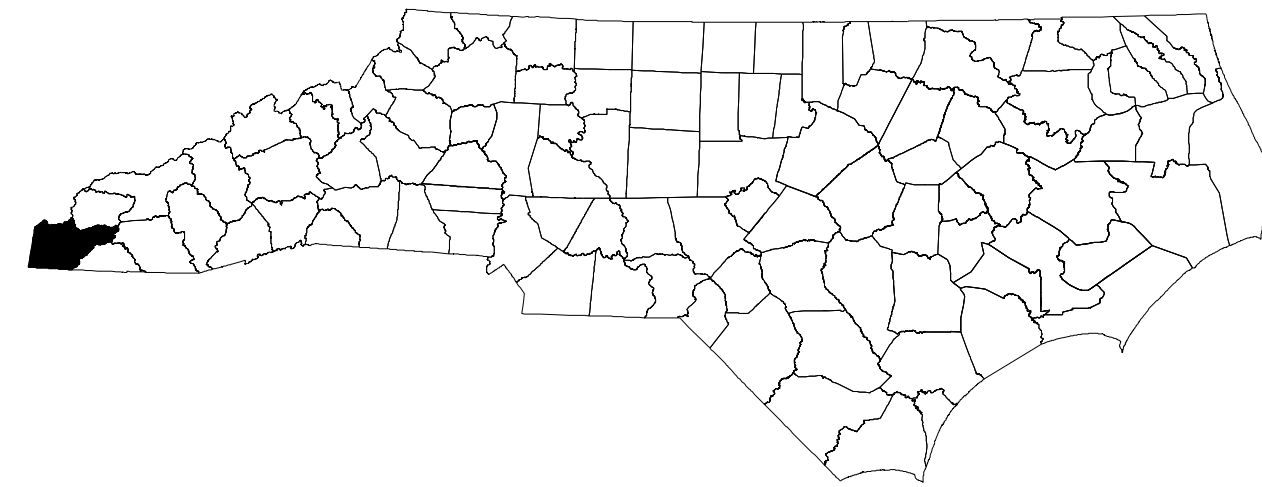

**LOCATION: BRIDGE NO. 190009 ON US 64 & US 74 EBL OVER NOTTELEY RIVER AND GRAVEL RD.
BRIDGE NO. 190010 ON US 64 & US 74 WBL OVER NOTTELEY RIVER AND GRAVEL RD.**

TYPE OF WORK: BRIDGE PRESERVATION - DECK REPAIR, LATEX MODIFIED CONCRETE (LMC) OVERLAY, FOAM JOINT SEALS FOR PRESERVATION, LINK SLAB FOR PRESERVATION, REPAIRS TO PRESTRESSED CONCRETE GIRDERS, PAINTING EXISTING WEATHERING STEEL BEAM ENDS, PAINTING EXISTING NON WEATHERING STEEL BEAMS, CLEANING AND PAINTING EXISTING BEARING WITH HRCSA, EPOXY COATING CONCRETE GIRDER ENDS, EPOXY COATING AND DEBRIS REMOVAL FROM TOP OF END BENT AND BENT CAPS, SUBSTRUCTURE REPAIR.

SHEET NO.	TITLE
TMP-1	TITLE SHEET, VICINITY MAP, AND INDEX OF SHEETS
TMP-1A	LIST OF APPLICABLE ROADWAY STANDARD DRAWINGS, AND LEGEND
TMP-1B	TRANSPORTATION OPERATIONS PLAN: GENERAL NOTES
TMP-1C	TRANSPORTATION OPERATIONS PLAN: PHASING
TMP-2	TYPICAL SECTIONS
TMP-3	PLAN VIEW - TRAFFIC SHIFT

SHEET NO.
TMP-1

15BPR.125.3

TIP PROJECT:

9/20/2023 Y:\Special\15BPR\TrafficControl\15BPR.61.TC.TMP.L.dgn User:hdawandos

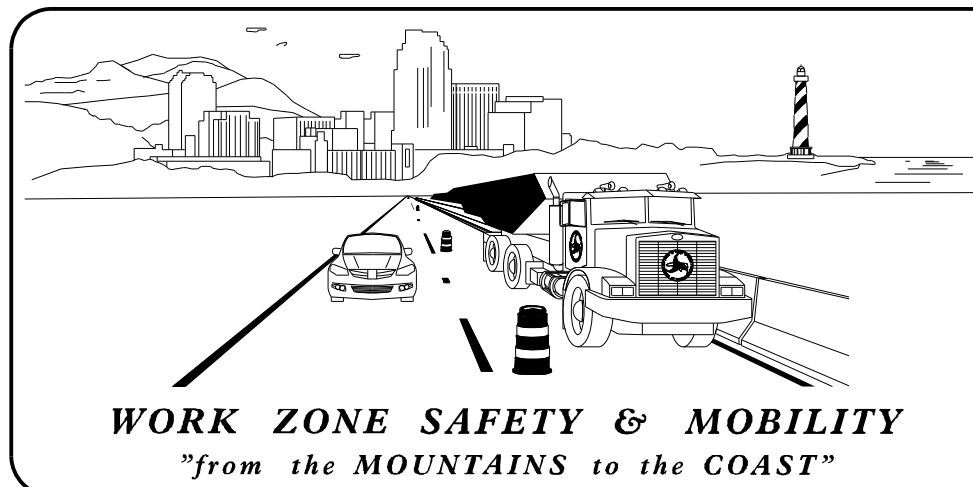

PLANS PREPARED BY:
HABIB A. LAWANDOS

NCDOT CONTACTS:
ZACHARY T. CLARK, P.E.
PROJECT ENGINEER
KARMEN E. DAIS, P.E.
PROJECT DESIGN ENGINEER

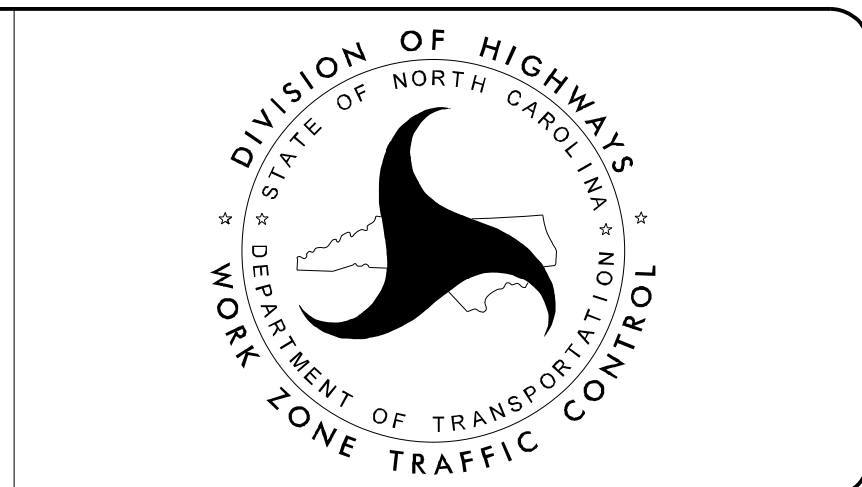

DOCUMENT NOT CONSIDERED FINAL
UNLESS ALL SIGNATURES COMPLETED

APPROVED: 
DATE: 10/03/2023

SEAL

GENERAL NOTES

CHANGES MAY BE REQUIRED WHEN PHYSICAL DIMENSIONS IN THE DETAIL DRAWINGS, STANDARD DETAILS, AND ROADWAY DETAILS ARE NOT ATTAINABLE TO MEET FIELD CONDITIONS OR RESULT IN DUPLICATE OR UNDESIRABLE OVERLAPPING OF DEVICES. MODIFICATION MAY INCLUDE: MOVING, SUPPLEMENTING, COVERING, OR REMOVAL OF DEVICES AS DIRECTED BY THE ENGINEER.

THE FOLLOWING GENERAL NOTES APPLY AT ALL TIMES FOR THE DURATION OF THE CONSTRUCTION PROJECT EXCEPT WHEN OTHERWISE NOTED IN THE PLAN OR DIRECTED BY THE ENGINEER.

TIME RESTRICTIONS

NOTE: THESE RESTRICTIONS DO NOT APPLY DURING THE 15-DAY LANE CLOSURES PER THE PHASING.

A) DO NOT CLOSE OR NARROW TRAVEL LANES AS FOLLOWS:

ROAD NAME	DAY AND TIME RESTRICTIONS
US 64 / US 74	MONDAY THRU FRIDAY 7:00 A.M. - 9:00 A.M. 4:00 P.M. - 6:00 P.M.

B) DO NOT CLOSE OR NARROW TRAVEL LANES DURING HOLIDAYS AND SPECIAL EVENTS AS FOLLOWS:

ROAD NAME
US 64 / US 74

HOLIDAY

- FOR ANY UNEXPECTED OCCURRENCE THAT CREATES UNUSUALLY HIGH TRAFFIC VOLUMES, AS DIRECTED BY THE ENGINEER.
- FOR NEW YEAR'S, BETWEEN THE HOURS OF 7:00 A.M. DECEMBER 31st TO 7:00 P.M. JANUARY 2ND. IF NEW YEAR'S DAY IS ON A FRIDAY, SATURDAY, SUNDAY, OR MONDAY THEN UNTIL 6:00 P.M. THE FOLLOWING TUESDAY.
- FOR EASTER, BETWEEN THE HOURS OF 7:00 A.M. THURSDAY AND 6:00 P.M. MONDAY.
- FOR MEMORIAL DAY, BETWEEN THE HOURS OF 7:00 A.M. FRIDAY TO 6:00 P.M. TUESDAY.
- FOR INDEPENDENCE DAY, BETWEEN THE HOURS OF 7:00 A.M. THE DAY BEFORE INDEPENDENCE DAY AND 6:00 P.M. THE DAY AFTER INDEPENDENCE DAY.

IF INDEPENDENCE DAY IS ON A FRIDAY, SATURDAY, SUNDAY OR MONDAY THEN BETWEEN THE HOURS OF 7:00 A.M. THE THURSDAY BEFORE INDEPENDENCE DAY AND 6:00 P.M. THE TUESDAY AFTER INDEPENDENCE DAY.

- FOR LABOR DAY, BETWEEN THE HOURS OF 7:00 A.M. FRIDAY AND 6:00 P.M. TUESDAY.
- FOR THANKSGIVING DAY, BETWEEN THE HOURS OF 7:00 A.M. TUESDAY TO 6:00 P.M. MONDAY.
- FOR CHRISTMAS, BETWEEN THE HOURS OF 7:00 A.M. THE FRIDAY BEFORE THE WEEK OF CHRISTMAS DAY AND 6:00 P.M. THE FOLLOWING TUESDAY AFTER THE WEEK OF CHRISTMAS.
- FOR LEAF SEASON, ALL WEEKENDS BETWEEN OCTOBER 12TH AND OCTOBER 31ST, BETWEEN THE HOURS OF 7:00 A.M. THE FRIDAY AND 6:00 P.M. THE FOLLOWING MONDAY.

C) DO NOT STOP TRAFFIC AS FOLLOWS:

ROAD NAME	DAY AND TIME RESTRICTIONS DURATION & OPERATION
US 64 / US 74	MONDAY THRU SUNDAY 6:00 A.M. - 7:00 P.M. 20 MINUTES FOR ANY TRAFFIC OPERATION REQUIRING TRAFFIC TO BE STOPPED

LANE AND SHOULDER CLOSURE REQUIREMENTS

- D) REMOVE LANE CLOSURE DEVICES FROM THE LANE WHEN WORK IS NOT BEING PERFORMED BEHIND THE LANE CLOSURE OR WHEN A LANE CLOSURE IS NO LONGER NEEDED OR AS DIRECTED BY THE ENGINEER.
- E) WHEN PERSONNEL AND/OR EQUIPMENT ARE WORKING WITHIN 15 FT OF AN OPEN TRAVEL LANE, CLOSE THE NEAREST OPEN SHOULDER USING ROADWAY STANDARD DRAWING NO. 1101.04 UNLESS THE WORK AREA IS PROTECTED BY BARRIER OR GUARDRAIL OR A LANE CLOSURE IS INSTALLED.
- F) WHEN PERSONNEL AND/OR EQUIPMENT ARE WORKING ON THE SHOULDER ADJACENT TO AN UNDIVIDED FACILITY AND WITHIN 5 FT OF AN OPEN TRAVEL LANE, CLOSE THE NEAREST OPEN TRAVEL LANE USING ROADWAY STANDARD DRAWING NO. 1101.02 UNLESS THE WORK AREA IS PROTECTED BY BARRIER OR GUARDRAIL.
- G) WHEN PERSONNEL AND/OR EQUIPMENT ARE WORKING WITHIN A LANE OF TRAVEL OF AN UNDIVIDED OR DIVIDED FACILITY, CLOSE THE LANE ACCORDING TO THE TRAFFIC CONTROL PLANS, ROADWAY STANDARD DRAWINGS, OR AS DIRECTED BY THE ENGINEER. CONDUCT THE WORK SO THAT ALL PERSONNEL AND/OR EQUIPMENT REMAIN WITHIN THE CLOSED TRAVEL LANE.
- H) DO NOT WORK SIMULTANEOUSLY WITHIN 15 FT ON BOTH SIDES OF AN OPEN TRAVELWAY, RAMP, OR LOOP WITHIN THE SAME LOCATION UNLESS PROTECTED WITH GUARDRAIL OR BARRIER.
- I) DO NOT INSTALL MORE THAN ONE LANE CLOSURE IN ANY ONE DIRECTION ON US 64 / US 74.

PAVEMENT EDGE DROP OFF REQUIREMENTS

- J) DO NOT EXCEED A DIFFERENCE OF 2 INCHES IN ELEVATION BETWEEN OPEN LANES OF TRAFFIC FOR NOMINAL LIFTS OF 1.5 INCHES. INSTALL ADVANCE WARNING "UNEVEN LANES" SIGNS (W8-11) IN ADVANCE AND A MINIMUM OF EVERY HALF MILE THROUGHOUT THE UNEVEN AREA.

TRAFFIC PATTERN ALTERATIONS

- K) NOTIFY THE ENGINEER THIRTY (30) CALENDAR DAYS PRIOR TO ANY TRAFFIC PATTERN ALTERATION.

SIGNING

- L) INSTALL ADVANCE WORK ZONE WARNING SIGNS WHEN WORK IS WITHIN 40 FT FROM THE EDGE OF TRAVEL LANE AND NO MORE THAN THREE (3) DAYS PRIOR TO THE BEGINNING OF CONSTRUCTION.
- M) ENSURE ALL NECESSARY SIGNING IS IN PLACE PRIOR TO ALTERING ANY TRAFFIC PATTERN.
- N) INSTALL BLACK ON ORANGE "DIP" SIGNS (W8-2) AND/OR "BUMP" SIGNS (W8-1) IN ADVANCE OF THE UNEVEN AREA, OR AS DIRECTED BY THE ENGINEER.

TRAFFIC BARRIER

- O) INSTALL TEMPORARY BARRIER ACCORDING TO THE TRANSPORTATION MANAGEMENT PLANS A MAXIMUM OF TWO (2) WEEKS PRIOR TO BEGINNING WORK IN ANY LOCATION. ONCE TEMPORARY BARRIER IS INSTALLED AT ANY LOCATION PROCEED IN A CONTINUOUS MANNER TO COMPLETE THE PROPOSED WORK IN THAT LOCATION UNLESS OTHERWISE STATED IN THE TRANSPORTATION MANAGEMENT PLANS OR AS DIRECTED BY THE ENGINEER.

DO NOT PLACE BARRIER DIRECTLY ON ANY SURFACE OTHER THAN ASPHALT OR CONCRETE.

ONCE TEMPORARY BARRIER IS INSTALLED AT ANY LOCATION AND NO WORK IS PERFORMED BEHIND THE TEMPORARY BARRIER FOR A PERIOD LONGER THAN TWO (2) MONTHS, REMOVE / RESET TEMPORARY BARRIER AT NO COST TO THE DEPARTMENT UNLESS OTHERWISE STATED IN THE TRANSPORTATION MANAGEMENT PLANS, TEMPORARY BARRIER IS PROTECTING A HAZARD, OR AS DIRECTED BY THE ENGINEER.

INSTALL TEMPORARY BARRIER WITH THE TRAFFIC FLOW BEGINNING WITH THE UPSTREAM SIDE OF TRAFFIC. REMOVE TEMPORARY BARRIER AGAINST THE TRAFFIC FLOW BEGINNING WITH THE DOWNSTREAM SIDE OF TRAFFIC.

INSTALL AND SPACE DRUMS NO GREATER THAN TWICE THE POSTED SPEED LIMIT (MPH) TO CLOSE OR KEEP THE SECTION OF THE ROADWAY CLOSED UNTIL THE TEMPORARY BARRIER CAN BE PLACED OR AFTER THE TEMPORARY BARRIER IS REMOVED.

- P) PROTECT THE APPROACH END OF MOVABLE/PORTABLE CONCRETE BARRIER AT ALL TIMES DURING THE INSTALLATION AND REMOVAL OF THE BARRIER BY EITHER A TRUCK MOUNTED ATTENUATOR (MAXIMUM 72 HOURS) OR A TEMPORARY CRASH CUSHION.

PROTECT THE APPROACH END OF MOVABLE/PORTABLE CONCRETE BARRIER FROM ONCOMING TRAFFIC AT ALL TIMES BY A TEMPORARY CRASH CUSHION UNLESS THE APPROACH END OF MOVABLE/PORTABLE CONCRETE BARRIER IS OFFSET FROM ONCOMING TRAFFIC AS FOLLOWS OR AS SHOWN IN THE PLANS: (SEE ALSO 1101.05)

POSTED SPEED LIMIT	MINIMUM OFFSET
40 OR LESS	15 FT
45 - 50	20 FT
55	25 FT
60 MPH or HIGHER	30 FT

TRAFFIC CONTROL DEVICES

- Q) WHEN LANE CLOSURES ARE NOT IN EFFECT SPACE CHANNELIZING DEVICES IN WORK AREAS NO GREATER IN FEET THAN TWICE THE POSTED SPEED LIMIT (MPH) EXCEPT, 10 FT ON-CENTER IN RADII, AND 3 FT OFF THE EDGE OF AN OPEN TRAVELWAY. REFER TO STANDARD SPECIFICATIONS FOR ROADS AND STRUCTURES SECTIONS 1130 (DRUMS), 1135 (CONES) AND 1180 (SKINNY DRUMS) FOR ADDITIONAL REQUIREMENTS.

PAVEMENT MARKINGS AND MARKERS

- R) INSTALL TEMPORARY PAVEMENT MARKINGS AND TEMPORARY PAVEMENT MARKERS ON INTERIM LAYERS OF PAVEMENT AS FOLLOWS:



ROAD NAME	MARKING
US 64 / US 74	COLD APPLIED PLASTIC TYPE IV (REMOVABLE TAPE)

- S) TIE PROPOSED PAVEMENT MARKING LINES TO EXISTING PAVEMENT MARKING LINES.

- T) REMOVE/REPLACE ANY CONFLICTING/DAMAGED PAVEMENT MARKINGS AND MARKERS BY THE END OF EACH DAY'S OPERATION.

MISCELLANEOUS

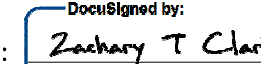
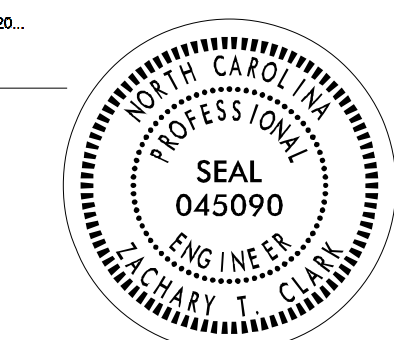
- U) COORDINATE WITH THE ENGINEER AND THE OVERSIZE/OVERWEIGHT PERMIT UNIT AT 919-814-3700 FOR WIDE-LOAD DETOUR ROUTES WHEN 16' CLEAR ROADWAY WIDTH IS NOT PROVIDED.

<p>APPROVED:  SC42A7F17FD420...</p> <p>DATE: 10/03/2023</p> <div style="text-align: center;">  </div>		<h2 style="margin: 0;">TRANSPORTATION OPERATIONS PLAN: GENERAL NOTES</h2>
DOCUMENT NOT CONSIDERED FINAL UNLESS ALL SIGNATURES COMPLETED		

PHASING

PHASE I

STEP 1:
USING RSD 1101.01, SHEET 1 OF 3, INSTALL ADVANCE WORK ZONE WARNING SIGNS ON US 64 / US 74.

COMPLETE THE WORK REQUIRED OF PHASE I STEP 2A-2D WITHIN FIFTEEN (15) CONSECUTIVE CALENDAR DAYS FOR EACH LANE. SEE INTERMEDIATE CONTRACT TIMES AND LIQUIDATED DAMAGES.

NOTES:

- THE CONTRACTOR SHALL COORDINATE WITH THE ENGINEER FOR WHICH LANE / DIRECTION TO START CONSTRUCTION.
- THE CONTRACTOR SHALL NOT CLOSE MORE THAN ONE LANE AT A TIME IN EACH DIRECTION.
- THE CONTRACTOR MAY ELECT TO WORK ON ONE LANE IN EACH DIRECTION AT THE SAME TIME.

STEP 2:
USING RSD 1101.02, SHEET 4 OF 14 (WITH STATIONARY SIGNS IN LIEU OF PORTABLE SIGNS) AND SHEETS TMP-2 & TMP-3, PERFORM BRIDGE WORK AS FOLLOWS:

- A- INSTALL ANCHORED PCB, CRASH CUSHION, AND TEMPORARY PAVEMENT MARKINGS AS SHOWN ON SHEETS TMP-2 & 3.
NOTE: REMOVE ALL CONFLICTING PAVEMENT MARKING AS NECESSARY.
- B- COMPLETE DEMOLITION OF BRIDGE DECK AND CONSTRUCTION OF LINK SLABS IN THE CLOSED LANE ACCORDING TO THE CONSTRUCTION PLANS.
- C- COMPLETE SCARIFICATION, HYDRODEMOLITION, AND LMC OVERLAY IN THE CLOSED LANE ACCORDING TO THE CONSTRUCTION PLANS.
- D- PLACE TEMPORARY PAVEMENT MARKING, REMOVE CONFLICTING PAVEMENT MARKING, REMOVE OR RESET ANCHORED PCB, AND OPEN THIS LANE TO TRAFFIC.

NOTE: REPEAT STEP 2A-2D FOR EACH LANE IN BOTH DIRECTIONS OF US 64 / US 74.

STEP 3:
UPON COMPLETION OF PROPOSED CONSTRUCTION OF BOTH BRIDGES, REMOVE PCB, PLACE TEMPORARY PAVEMENT MARKING IN EXISTING PATTERN, AND OPEN TO TRAFFIC.

STEP 4:
USING SHORT TERM LANE CLOSURE, RSD 1101.02, SHEET 4 OF 14, PLACE FINAL PAVEMENT MARKINGS AND MARKERS IN THE EXISTING TRAFFIC PATTERN AND OPEN TO TRAFFIC.

STEP 5:
REMOVE ALL REMAINING TRAFFIC CONTROL DEVICES.

10/2/2023
Y:\Special\15BPR\TrafficControl\TCP\15BPR.61.TC.TMP.1C.dgn
User:hdawandos

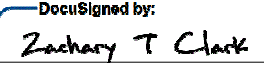
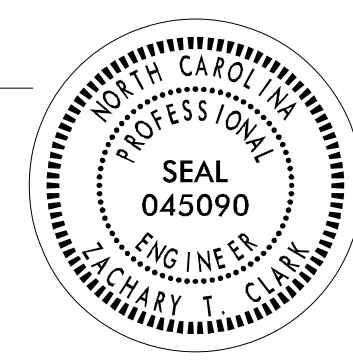
APPROVED:  <small>DocuSigned by: Zachary T. Clark 9C4DA7F17F8D420...</small>	
DATE: 10/03/2023	
DOCUMENT NOT CONSIDERED FINAL UNLESS ALL SIGNATURES COMPLETED	

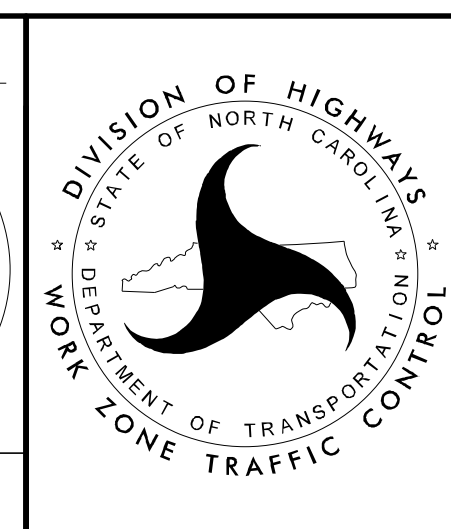

PHASING

BRIDGE #: 190009
US 64 / US 74 EB

THE DURATION OF ANY LANE CLOSURE IS
FIFTEEN (15) CONS. CALENDAR DAYS ONLY

BRIDGE #: 190010
US 64 / US 74 WB

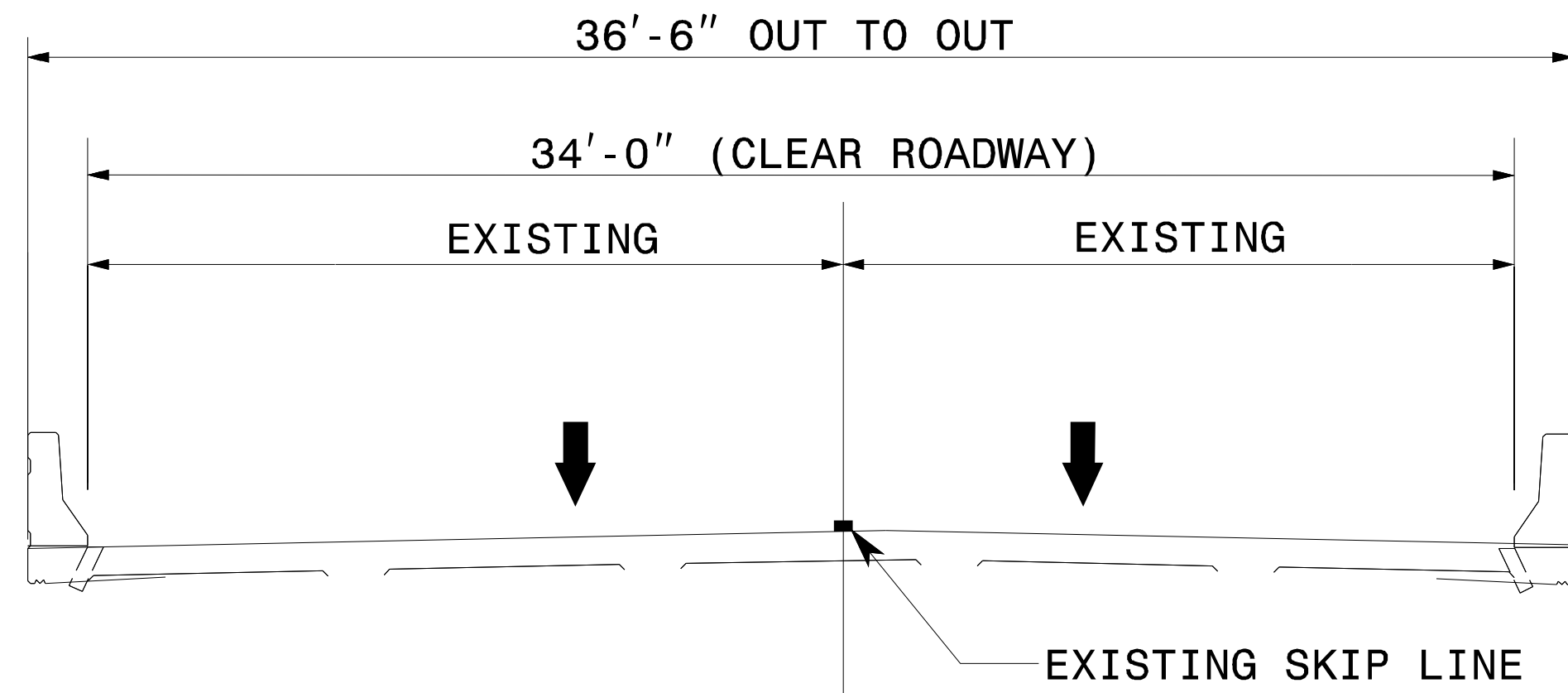

EXISTING

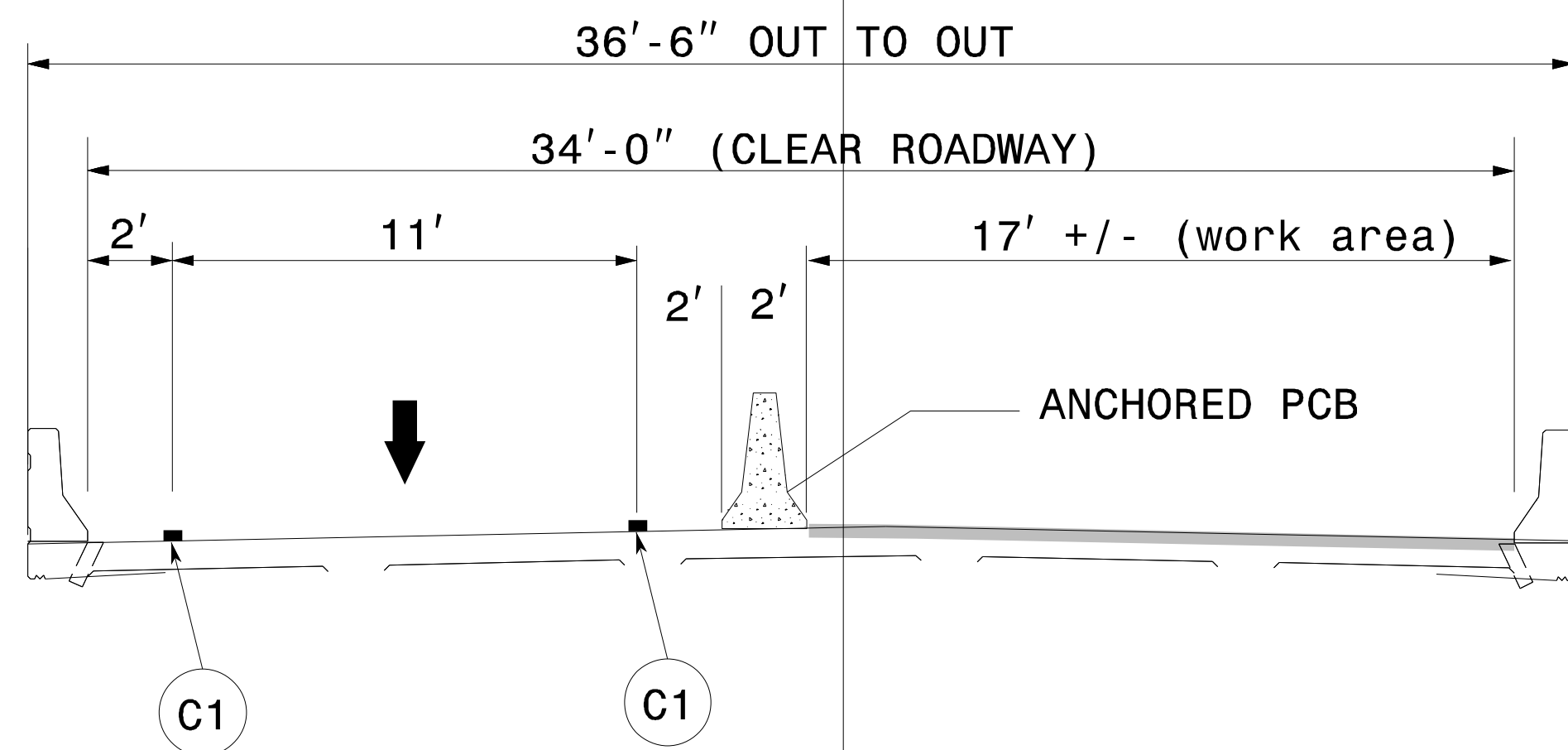

LEFT LANE LMC WORK

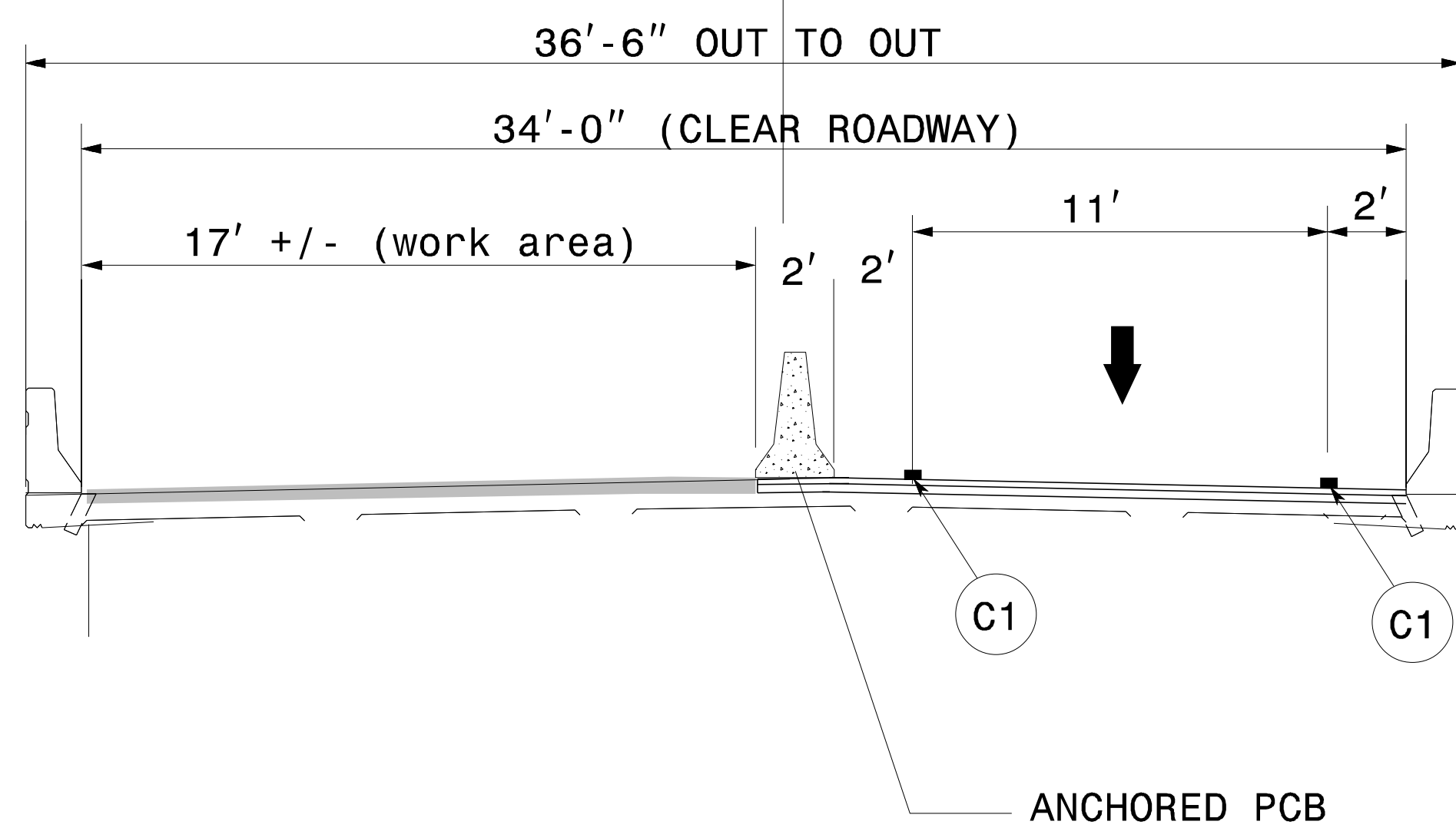

RIGHT LANE LMC WORK

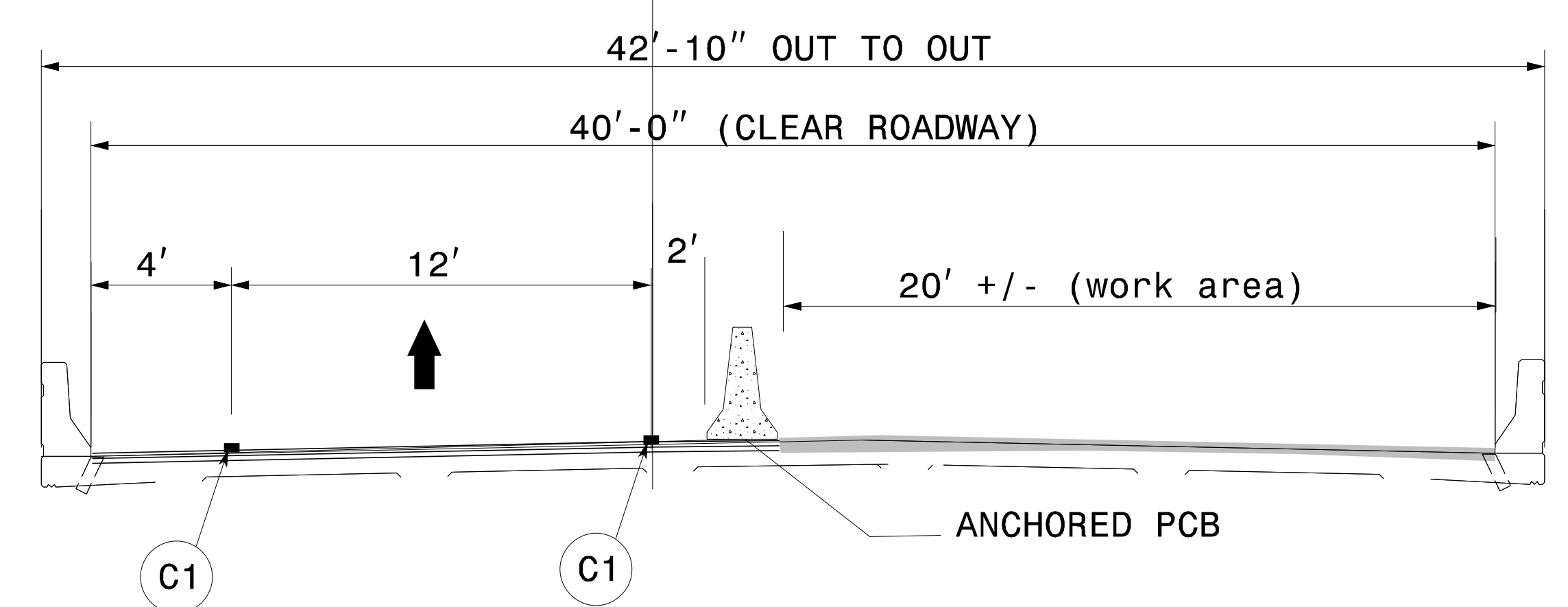
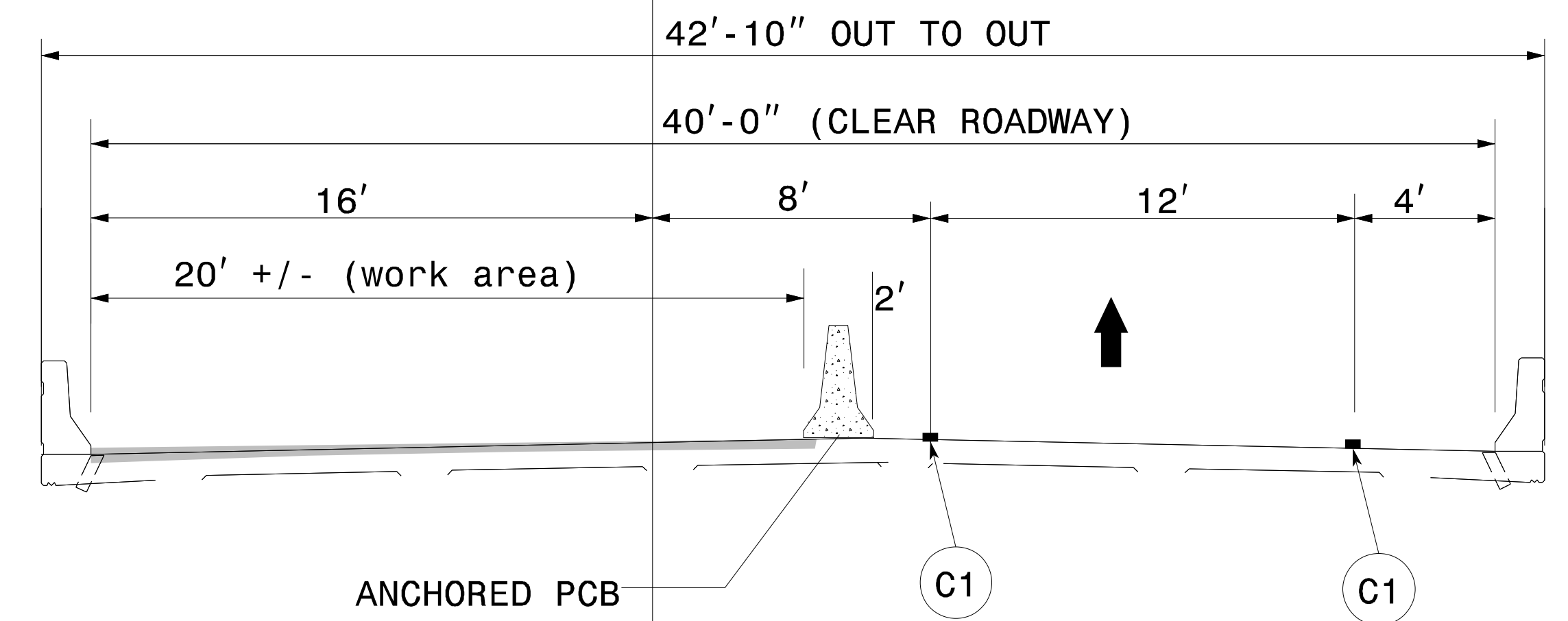
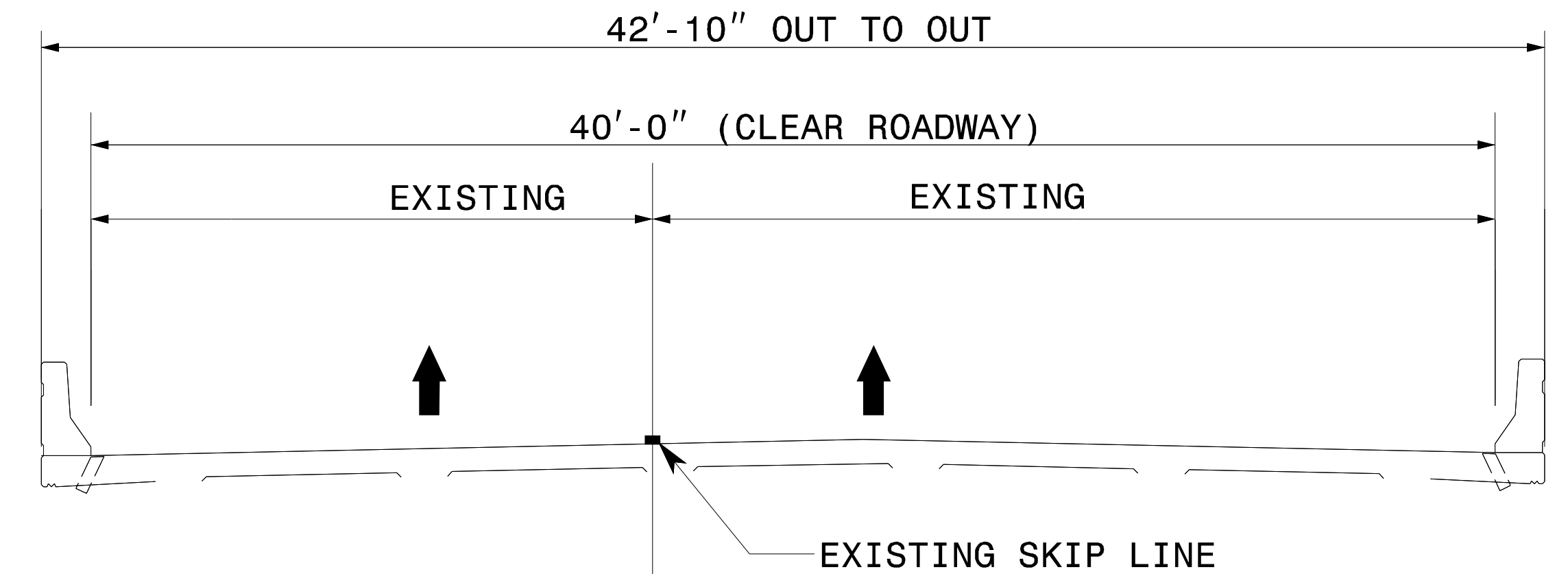

10/2/2023
Y:\Special\15BPR\15BPR\TrafficControl\15BPR.61.TC.TMP.2.dgn
User:hdawandos

APPROVED: *Zachary T. Clark*
DATE: 10/03/2023

SEAL
045090
ENGINEER
ZACHARY T. CLARK

**DOCUMENT NOT CONSIDERED FINAL
UNLESS ALL SIGNATURES COMPLETED**

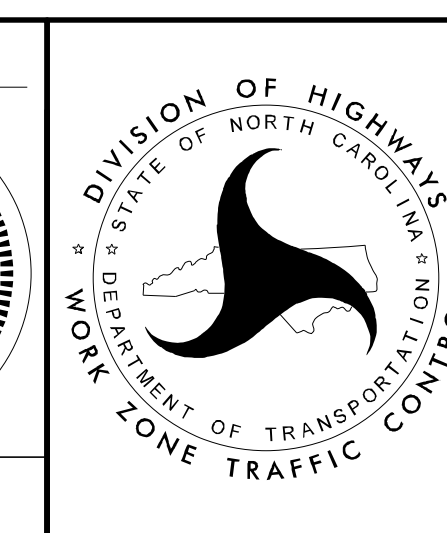

TYPICAL SECTIONS

EXISTING



LEFT LANE LMC WORK

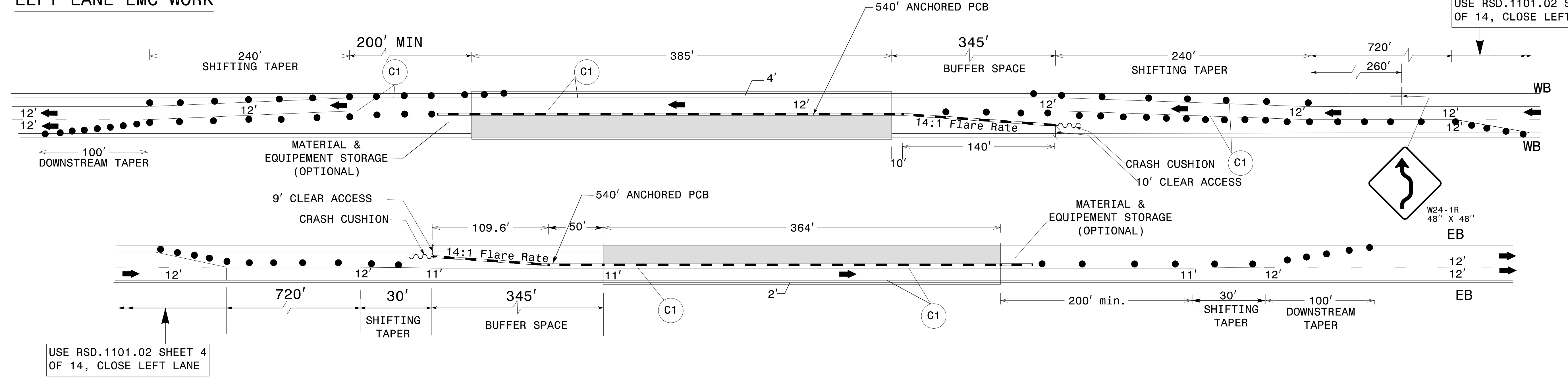

RIGHT LANE LMC WORK

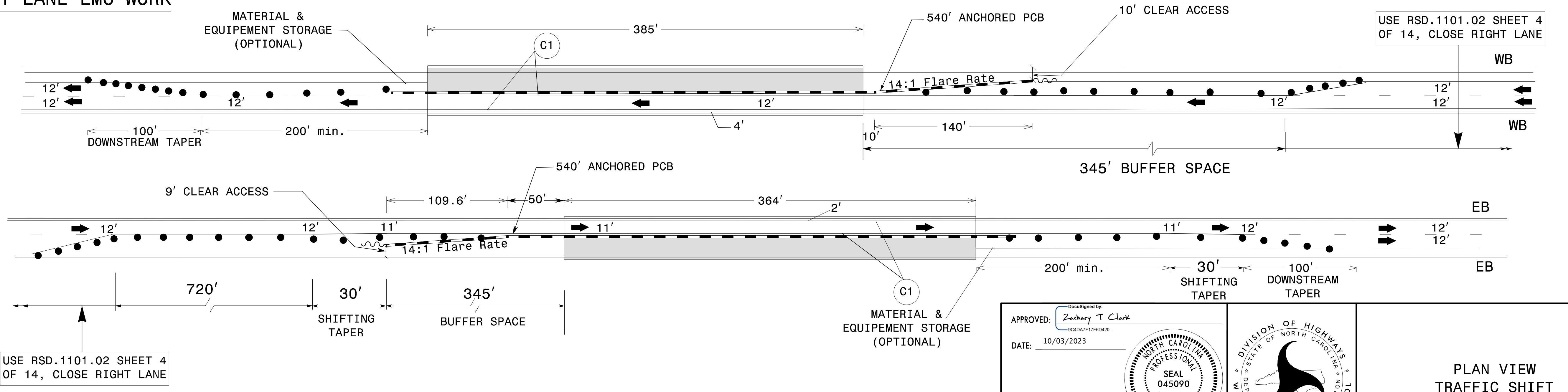

APPROVED: *Zachary T. Clark*
 DATE: 10/03/2023

Professional Engineer Seal: Zachary T. Clark, No. 045090, State of North Carolina.

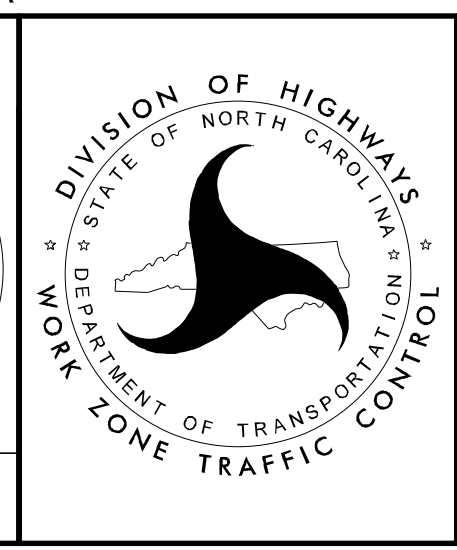

**PLAN VIEW
TRAFFIC SHIFT**

10/3/2023
 Y:\Special\15BPR\N-TrafficControl\TCP\15BPR.61.TC_TMP_3.dgn
 User:hdawandos