

8/17/99
05-MAY-2023 17:07
R:\Roadway\Projects\5799_Roadway\RA1-Details.dgn

ROUNDBABOUT -RA1- DETAIL

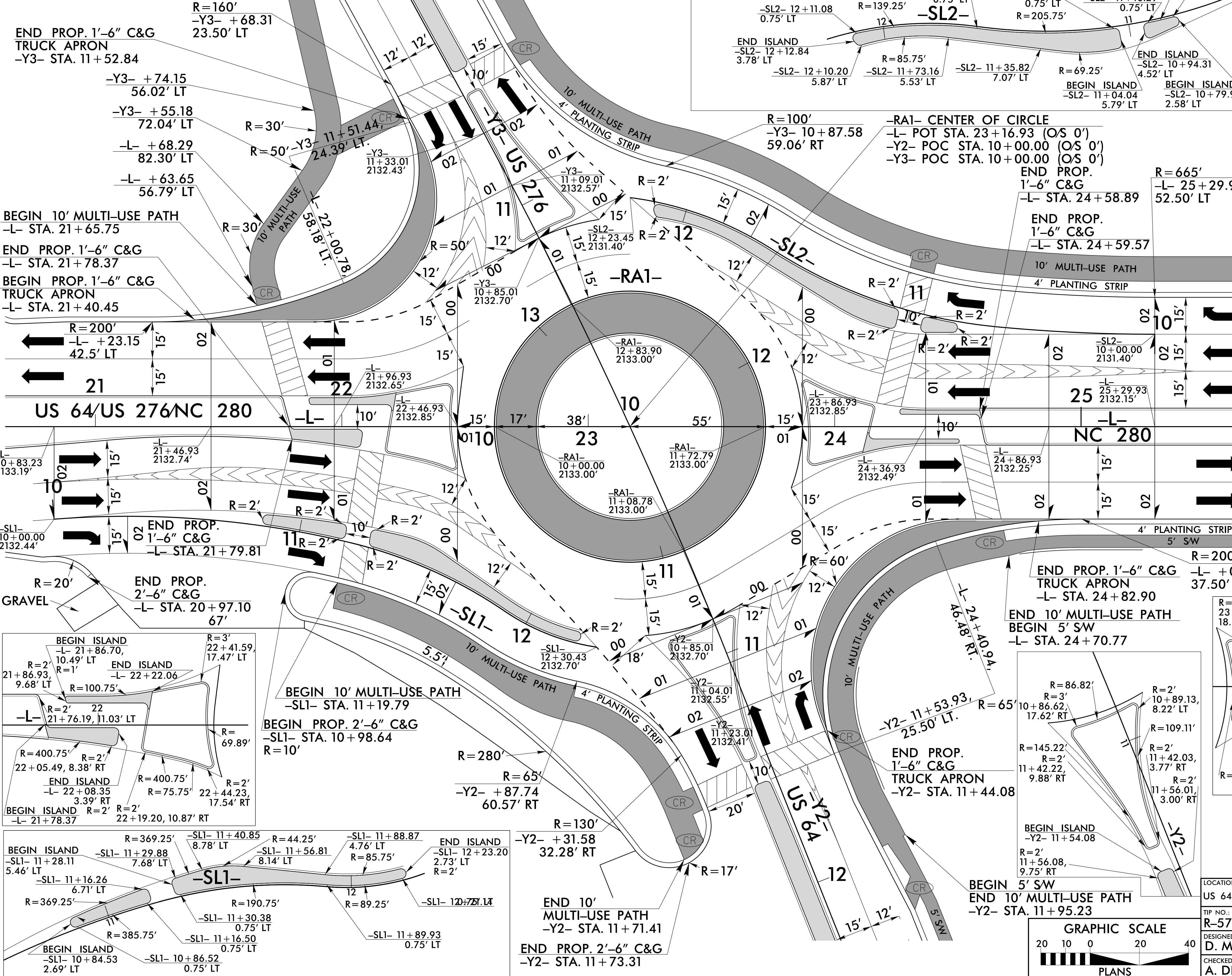

PROJECT REFERENCE NO. R-5799	SHEET NO. 2B-2
ROADWAY DESIGN ENGINEER SEAN M. MORROW, PE 6/15/2023	

DOCUMENT NOT CONSIDERED FINAL UNLESS ALL SIGNATURES COMPLETED

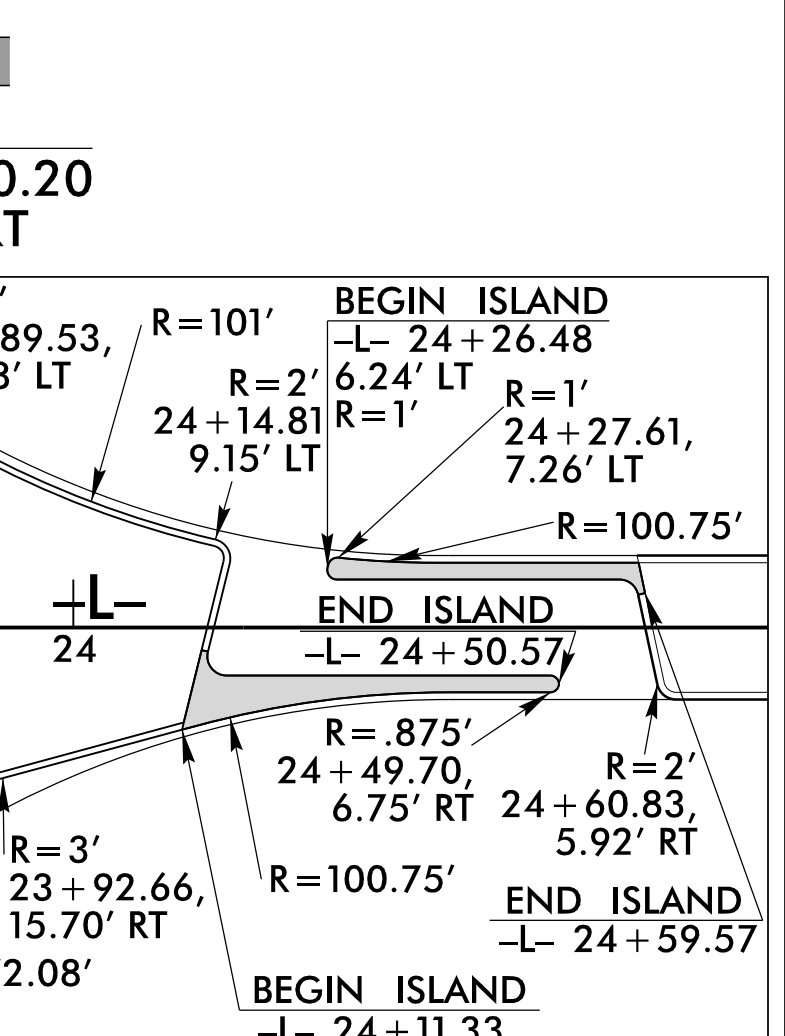
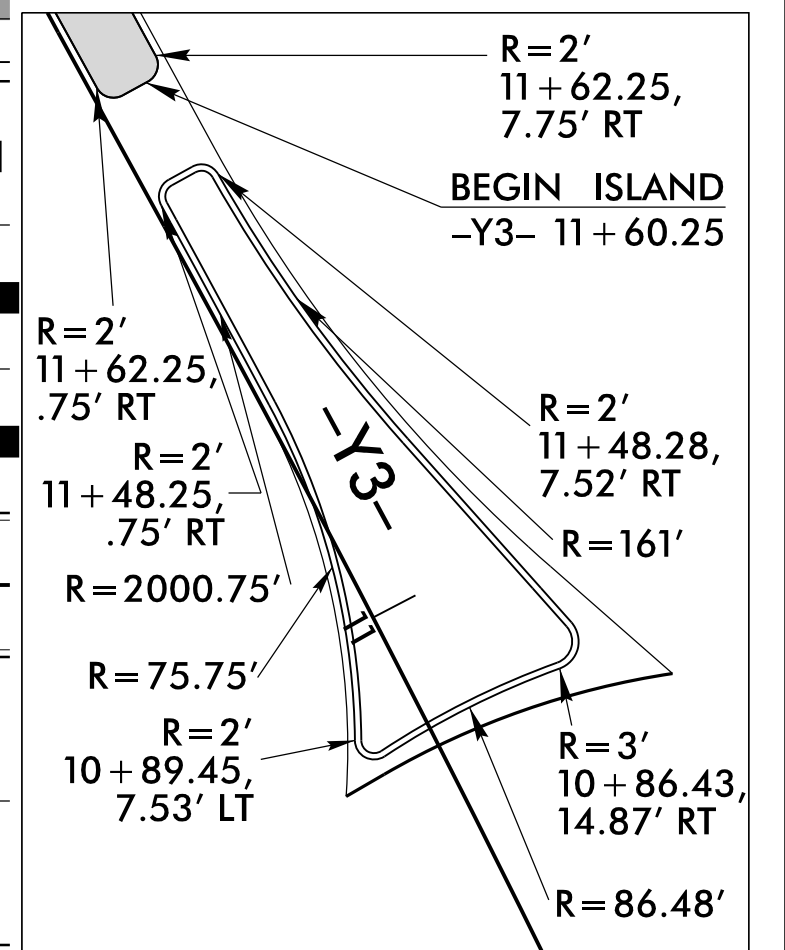
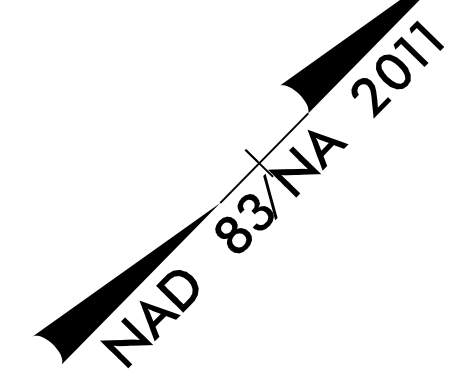

- PROP. SIDEWALK & MULTI-USE PATH
- PROP. MONO. ISLAND
- PROP. CURB RAMPS

LOCATION:
US 64 AND US 276/NC 280 INTERSECTION

TIP NO.:
R-5799

COUNTY:
TRANSYLVANIA

DESIGNED BY:
D. MORROW, PE

CHECKED BY:
A. DRAKE, PE

DATE:
7/1/2021

