

STATE OF NORTH CAROLINA  
DEPARTMENT OF TRANSPORTATION  
RALEIGH, N.C.

PROPOSAL

DATE AND TIME OF BID OPENING: **Aug 15, 2023 AT 02:00 PM**

CONTRACT ID C204462  
WBS 15BPR.124.3

FEDERAL-AID NO. STATE FUNDED  
COUNTY WAKE, DURHAM

T.I.P NO.

MILES 0.260

ROUTE NO.

LOCATION BRGS #306 OVER I-40 ON SR-1118, #39 OVER CRABTREE CRK ON SR-2517, AND #83 OVER US-1 & #84 OVER RICHLAND CRK ON NC-98.

TYPE OF WORK BRIDGE PRESERVATION.

**NOTICE:**

ALL BIDDERS SHALL COMPLY WITH ALL APPLICABLE LAWS REGULATING THE PRACTICE OF GENERAL CONTRACTING AS CONTAINED IN CHAPTER 87 OF THE GENERAL STATUTES OF NORTH CAROLINA WHICH REQUIRES THE BIDDER TO BE LICENSED BY THE N.C. LICENSING BOARD FOR CONTRACTORS WHEN BIDDING ON ANY NON-FEDERAL AID PROJECT WHERE THE BID IS \$30,000 OR MORE, EXCEPT FOR CERTAIN SPECIALTY WORK AS DETERMINED BY THE LICENSING BOARD. BIDDERS SHALL ALSO COMPLY WITH ALL OTHER APPLICABLE LAWS REGULATING THE PRACTICES OF ELECTRICAL, PLUMBING, HEATING AND AIR CONDITIONING AND REFRIGERATION CONTRACTING AS CONTAINED IN CHAPTER 87 OF THE GENERAL STATUTES OF NORTH CAROLINA. NOTWITHSTANDING THESE LIMITATIONS ON BIDDING, THE BIDDER WHO IS AWARDED ANY FEDERAL - AID FUNDED PROJECT SHALL COMPLY WITH CHAPTER 87 OF THE GENERAL STATUTES OF NORTH CAROLINA FOR LICENSING REQUIREMENTS WITHIN 60 CALENDAR DAYS OF BID OPENING.

**BIDS WILL BE RECEIVED AS SHOWN BELOW:**

**THIS IS A STRUCTURE PROPOSAL**

**5% BID BOND OR BID DEPOSIT REQUIRED**

---

**PROPOSAL FOR THE CONSTRUCTION OF  
CONTRACT No. C204462 IN DURHAM AND WAKE COUNTIES, NORTH CAROLINA  
DEPARTMENT OF TRANSPORTATION,  
RALEIGH, NORTH CAROLINA**

The Bidder has carefully examined the location of the proposed work to be known as Contract No. **C204462** has carefully examined the plans and specifications, which are acknowledged to be part of the proposal, the special provisions, the proposal, the form of contract, and the forms of contract payment bond and contract performance bond; and thoroughly understands the stipulations, requirements and provisions. The undersigned bidder agrees to be bound upon his execution of the bid and subsequent award to him by the Board of Transportation in accordance with this proposal to provide the necessary contract payment bond and contract performance bond within fourteen days after the written notice of award is received by him. The undersigned Bidder further agrees to provide all necessary machinery, tools, labor, and other means of construction; and to do all the work and to furnish all materials, except as otherwise noted, necessary to perform and complete the said contract in accordance with *the 2018 Standard Specifications for Roads and Structures* by the dates(s) specified in the Project Special Provisions and in accordance with the requirements of the Engineer, and at the unit or lump sum prices, as the case may be, for the various items given on the sheets contained herein.

The Bidder shall provide and furnish all the materials, machinery, implements, appliances and tools, and perform the work and required labor to construct and complete State Highway Contract No. **C204462** in **Durham and Wake Counties**, for the unit or lump sum prices, as the case may be, bid by the Bidder in his bid and according to the proposal, plans, and specifications prepared by said Department, which proposal, plans, and specifications show the details covering this project, and hereby become a part of this contract.

The published volume entitled *North Carolina Department of Transportation, Raleigh, Standard Specifications for Roads and Structures, January 2018* with all amendments and supplements thereto, is by reference incorporated into and made a part of this contract; that, except as herein modified, all the construction and work included in this contract is to be done in accordance with the specifications contained in said volume, and amendments and supplements thereto, under the direction of the Engineer.

If the proposal is accepted and the award is made, the contract is valid only when signed either by the Contract Officer or such other person as may be designated by the Secretary to sign for the Department of Transportation. The conditions and provisions herein cannot be changed except over the signature of the said Contract Officer.

The quantities shown in the itemized proposal for the project are considered to be approximate only and are given as the basis for comparison of bids. The Department of Transportation may increase or decrease the quantity of any item or portion of the work as may be deemed necessary or expedient.

An increase or decrease in the quantity of an item will not be regarded as sufficient ground for an increase or decrease in the unit prices, nor in the time allowed for the completion of the work, except as provided for the contract.

Accompanying this bid is a bid bond secured by a corporate surety, or certified check payable to the order of the Department of Transportation, for five percent of the total bid price, which deposit is to be forfeited as liquidated damages in case this bid is accepted and the Bidder shall fail to provide the required payment and performance bonds with the Department of Transportation, under the condition of this proposal, within 14 calendar days after the written notice of award is received by him, as provided in the *Standard Specifications*; otherwise said deposit will be returned to the Bidder.



*State Contract Officer*

DocuSigned by:

*Ronald Elton Davenport, Jr.*

F81B6038A47A442...

07/13/2023

## TABLE OF CONTENTS

### COVER SHEET PROPOSAL SHEET

### PROJECT SPECIAL PROVISIONS

CONTRACTOR PREQUALIFICATION:.....	G-1
INTERESTED PARTIES LIST:.....	G-2
LIABILITY INSURANCE:.....	G-3
CONTRACT TIME AND LIQUIDATED DAMAGES: .....	G-3
INTERMEDIATE CONTRACT TIME NUMBER 1 AND LIQUIDATED DAMAGES: .....	G-4
INTERMEDIATE CONTRACT TIME NUMBER 2 AND LIQUIDATED DAMAGES: .....	G-5
INTERMEDIATE CONTRACT TIME NUMBER 3 AND LIQUIDATED DAMAGES: .....	G-6
INTERMEDIATE CONTRACT TIME NUMBER 4 AND LIQUIDATED DAMAGES: .....	G-7
INTERMEDIATE CONTRACT TIME NUMBER 5 AND LIQUIDATED DAMAGES: .....	G-8
INTERMEDIATE CONTRACT TIME NUMBER 6 AND LIQUIDATED DAMAGES: .....	G-8
INTERMEDIATE CONTRACT TIME NUMBER 7 AND LIQUIDATED DAMAGES: .....	G-9
MAJOR CONTRACT ITEMS: .....	G-9
SPECIALTY ITEMS:.....	G-9
FUEL PRICE ADJUSTMENT:.....	G-9
SCHEDULE OF ESTIMATED COMPLETION PROGRESS:.....	G-11
MINORITY BUSINESS ENTERPRISE AND WOMEN BUSINESS ENTERPRISE:.....	G-11
CONTRACTOR'S LICENSE REQUIREMENTS:.....	G-26
RESTRICTIONS ON ITS EQUIPMENT AND SERVICES:.....	G-26
USE OF UNMANNED AIRCRAFT SYSTEM (UAS): .....	G-26
EQUIPMENT IDLING GUIDELINES:.....	G-27
ELECTRONIC BIDDING:.....	G-28
AWARD LIMITS: .....	G-28
TWELVE MONTH GUARANTEE:.....	G-28
OUTSOURCING OUTSIDE THE USA:.....	G-29
NOTE TO CONTRACTOR: .....	G-29
 ROADWAY.....	 R-1

### STANDARD SPECIAL PROVISIONS

AVAILABILITY FUNDS – TERMINATION OF CONTRACTS.....	SSP-1
NCDOT GENERAL SEED SPECIFICATION FOR SEED QUALITY .....	SSP-2
ERRATA.....	SSP-5
PLANT AND PEST QUARANTINES .....	SSP-13
MINIMUM WAGES .....	SSP-14
TITLE VI AND NONDISCRIMINATION .....	SSP-15
ON-THE-JOB TRAINING .....	SSP-23

### UNIT PROJECT SPECIAL PROVISIONS

EROSION CONTROL .....	EC-1
STRUCTURES .....	BP-1

**PROPOSAL ITEM SHEET**

ITEM SHEET(S)

**PROJECT SPECIAL PROVISIONS****GENERAL****CONTRACTOR PREQUALIFICATION:**

(10-18-22)(Rev. 7-18-23)

102

SP1 G01

Revise the *2018 Standard Specifications* as follows:

**Page 1-9, Subarticle 102-2(A)(1) Bidder Prequalification**, lines 34-36, delete and replace the first sentence with the following:

Applicant shall submit a completed Department Prequalification Application and *Bidder Experience Questionnaire*, along with any additional supporting information requested by the Department, as noted in the application and experience questionnaire package.

**Page 1-10, Subarticle 102-2(A) Bidder Prequalification**, lines 30-31, delete and replace the first sentence with the following:

Prospective bidders shall obtain prequalification approval at least two business days prior to any letting in which they intend to submit a bid. It is recommended that the prospective bidder file all required statements and documents with the State Prequalifications Engineer no less than 4 weeks before a given letting.

**Page 1-10, Subarticle 102-2(B) Purchase Order Bidder Prequalification**, lines 34-39, delete and replace the title and first paragraph with the following:

**(B) Purchase Order (PO) Prime Contractor Prequalification**

Contractors who have been approved to be placed on the Prequalified Bidders' List as noted above may perform work for the Department as a Purchase Order (PO) Prime Contractor and need not apply further. However, Purchase Order (PO) Prime Contractors will not be placed on the Prequalified Bidders' List unless they submit through the prequalification process described above.

**Page 1-9, Subarticle 102-2(B)(1) Purchase Order Bidder Prequalification**, lines 40-42, delete and replace the first sentence with the following:

Applicant shall submit a completed Department Prequalification Application along with any additional supporting information requested by the Department, as noted in the application.

**Page 1-11, Subarticle 102-2(B) Purchase Order Bidder Prequalification**, lines 16-18, delete and replace the first sentence with the following:

Prospective bidders shall obtain prequalification approval at least two business days prior to any letting in which they intend to submit a bid. It is recommended that the applicant file all required statements and documents with the State Prequalifications Engineer no less than 4 weeks before a given bid opening for their bid to be considered.

**Page 1-11, Subarticle 102-2(C) Subcontractor Prequalification**, lines 22-26, delete and replace the first paragraph with the following:

Contractors who have been approved to be placed on the Prequalified Bidders' List or the Purchase Order (PO) Prime Contractor's List as noted above may perform work for the Department as a subcontractor and need not apply further. However, subcontractors will not be placed on the Prequalified List or the Purchase Order (PO) Prime Contractor's List unless they submit through the prequalification process described above.

**Page 1-11, Subarticle 102-2(C)(1) Subcontractor Prequalification**, lines 27-28, delete and replace the first sentence with the following:

Applicant shall submit a completed Department Prequalification Application along with any additional supporting information requested by the Department, as noted in the application.

**Page 1-11, Subarticle 102-2(C) Subcontractor Prequalification**, lines 44-45, delete and replace the first sentence with the following:

The subcontractor shall file all required statements and documents with the State Prequalifications Engineer no less than 4 weeks before beginning work.

**Page 1-12, Subarticle 102-2(E) Renewal and Requalification**, lines 38-40, delete and replace the first sentence with the following:

It is recommended that the renewing or requalifying firm file all required statements and documents with the State Prequalifications Engineer no less than 4 weeks before a given letting for their bid to be considered.

**INTERESTED PARTIES LIST:**

(6-21-22)(Rev. 7-19-22)

102

SP1 G02

Revise the *2018 Standard Specifications* as follows:

**Page 1-12, Article 102-3 PROPOSALS AND PLAN HOLDER LISTS**, lines 45-49, delete and replace with the following:

**102-3 PROPOSALS AND INTERESTED PARTIES LIST**

On Department projects advertised, the prospective bidder shall sign up on the *Interested Parties List* no later than one business day prior to the Letting day of that project, for which he intends to submit a bid. There is no cost for signing up on the *Interested Parties List* that can be found on the Department's website at [connect.ncdot.gov/letting](http://connect.ncdot.gov/letting).

**Page 1-12, Article 102-3 PROPOSALS AND PLAN HOLDER LISTS**, lines 1-3, delete and replace the first sentence of the second paragraph with the following:

The proposal will state the location of the contemplated construction and show a schedule of

contract items with the approximate quantity of each of these items for which bid prices are invited.

**Page 1-14, Article 102-8 PREPARATION AND SUBMISSION OF BIDS**, lines 30-31, delete and replace the first paragraph with the following:

Prior to submitting a bid on a project, the bidder shall sign up on the *Interested Parties List* in conformance with Article 102-3. The bidder shall submit a unit or lump sum price for every item in the proposal other than items that are authorized alternates to those items for which a bid price has been submitted.

**LIABILITY INSURANCE:**

(5-16-23)

107

SP1 G05

Revise the *2018 Standard Specifications* as follows:

**Page 1-64, Article 107-15 LIABILITY INSURANCE**, replace the first sentence with the following:

The Contractor shall at its sole cost and expense obtain and furnish to the Department an original standard Association for Cooperative Operations Research and Development (ACORD) certificate of liability insurance evidencing commercial general liability with a limit for bodily injury and property damage in the amount of \$5,000,000 per occurrence and \$5,000,000 general aggregate, covering the Contractor from claims or damages for bodily injury, personal injury, or for property damages that may arise from operating under the contract by the employees and agents of the Contractor.

**CONTRACT TIME AND LIQUIDATED DAMAGES:**

(7-1-95) (Rev. 12-18-07)

108

SP1 G10 A

The date of availability for this contract is **September 25, 2023**.

The completion date for this contract is **September 1, 2025**.

Except where otherwise provided by the contract, observation periods required by the contract will not be a part of the work to be completed by the completion date and/or intermediate contract times stated in the contract. The acceptable completion of the observation periods that extend beyond the final completion date shall be a part of the work covered by the performance and payment bonds.

The liquidated damages for this contract are **One Thousand Five Hundred Dollars (\$ 1,500.00)** per calendar day.

**INTERMEDIATE CONTRACT TIME NUMBER 1 AND LIQUIDATED DAMAGES:**

(2-20-07)

108

SP1 G14 A

The Contractor shall complete the required work of installing, maintaining, and removing the traffic control devices for lane closures and restoring traffic to the existing traffic pattern. The Contractor shall not close or narrow a lane of traffic on **I-40** during the following time restrictions:

**DAY AND TIME RESTRICTIONS**

**Monday thru Sunday (Daily)  
5:00 A.M. to 11:00 P.M.**

In addition, the Contractor shall not close or narrow a lane of traffic on **I-40**, detain and/or alter the traffic flow on or during holidays, holiday weekends, special events, or any other time when traffic is unusually heavy, including the following schedules:

**HOLIDAY AND HOLIDAY WEEKEND LANE CLOSURE RESTRICTIONS**

1. For **unexpected occurrence** that creates unusually high traffic volumes, as directed by the Engineer.
2. For **New Year's Day**, between the hours of **5:00 A.M.** December 31<sup>st</sup> and **11:00 P.M.** January 2<sup>nd</sup>. If New Year's Day is on a Friday, Saturday, Sunday or Monday, then until **11:00 P.M.** the following Tuesday.
3. For **Easter**, between the hours of **5:00 A.M.** Thursday and **11:00 P.M.** Monday.
4. For **Memorial Day**, between the hours of **5:00 A.M.** Friday and **11:00 P.M.** Tuesday.
5. For **Independence Day**, between the hours of **5:00 A.M.** the day before Independence Day and **11:00 P.M.** the day after Independence Day.  
  
If **Independence Day** is on a Friday, Saturday, Sunday or Monday, then between the hours of **5:00 A.M.** the Thursday before Independence Day and **11:00 P.M.** the Tuesday after Independence Day.
6. For **Labor Day**, between the hours of **5:00 A.M.** Friday and **11:00 P.M.** Tuesday.
7. For **Thanksgiving**, between the hours of **5:00 A.M.** Tuesday and **11:00 P.M.** Monday.
8. For **Christmas**, between the hours of **5:00 A.M.** the Friday before the week of Christmas Day and **11:00 P.M.** the following Tuesday after the week of Christmas Day.

Holidays and holiday weekends shall include New Year's, Easter, Memorial Day, Independence Day, Labor Day, Thanksgiving, and Christmas. The Contractor shall schedule his work so that lane closures will not be required during these periods, unless otherwise directed by the Engineer.

The time of availability for this intermediate contract work shall be the time the Contractor begins to install all traffic control devices for lane closures according to the time restrictions listed herein.



The completion time for this intermediate contract work shall be the time the Contractor is required to complete the removal of all traffic control devices for lane closures according to the time restrictions stated above and place traffic in the existing traffic pattern.

The liquidated damages are **Two Thousand Five Hundred Dollars (\$ 2,500.00)** per fifteen (15) minute time period.

**INTERMEDIATE CONTRACT TIME NUMBER 2 AND LIQUIDATED DAMAGES:**

(2-20-07)

108

SP1 G14 A

The Contractor shall complete the required work of installing, maintaining, and removing the traffic control devices for lane closures and restoring traffic to the existing traffic pattern. The Contractor shall not close or narrow a lane of traffic on **US-1** during the following time restrictions:

DAY AND TIME RESTRICTIONS

**Monday thru Sunday (Daily)  
5:00 A.M. to 11:00 P.M.**

In addition, the Contractor shall not close or narrow a lane of traffic on **US-1**, detain and/or alter the traffic flow on or during holidays, holiday weekends, special events, or any other time when traffic is unusually heavy, including the following schedules:

HOLIDAY AND HOLIDAY WEEKEND LANE CLOSURE RESTRICTIONS

1. For **unexpected occurrence** that creates unusually high traffic volumes, as directed by the Engineer.
2. For **New Year's Day**, between the hours of **5:00 A.M.** December 31<sup>st</sup> and **11:00 P.M.** January 2<sup>nd</sup>. If New Year's Day is on a Friday, Saturday, Sunday or Monday, then until **11:00 P.M.** the following Tuesday.
3. For **Easter**, between the hours of **5:00 A.M.** Thursday and **11:00 P.M.** Monday.
4. For **Memorial Day**, between the hours of **5:00 A.M.** Friday and **11:00 P.M.** Tuesday.
5. For **Independence Day**, between the hours of **5:00 A.M.** the day before Independence Day and **11:00 P.M.** the day after Independence Day.  
  
If **Independence Day** is on a Friday, Saturday, Sunday or Monday, then between the hours of **5:00 A.M.** the Thursday before Independence Day and **11:00 P.M.** the Tuesday after Independence Day.
6. For **Labor Day**, between the hours of **5:00 A.M.** Friday and **11:00 P.M.** Tuesday.
7. For **Thanksgiving**, between the hours of **5:00 A.M.** Tuesday and **11:00 P.M.** Monday.

8. For **Christmas**, between the hours of **5:00 A.M.** the Friday before the week of Christmas Day and **11:00 P.M.** the following Tuesday after the week of Christmas Day.

Holidays and holiday weekends shall include New Year's, Easter, Memorial Day, Independence Day, Labor Day, Thanksgiving, and Christmas. The Contractor shall schedule his work so that lane closures will not be required during these periods, unless otherwise directed by the Engineer.

The time of availability for this intermediate contract work shall be the time the Contractor begins to install all traffic control devices for lane closures according to the time restrictions listed herein.

The completion time for this intermediate contract work shall be the time the Contractor is required to complete the removal of all traffic control devices for lane closures according to the time restrictions stated above and place traffic in the existing traffic pattern.

The liquidated damages are **One Thousand Two Hundred Fifty Dollars (\$ 1,250.00)** per fifteen **(15)** minute time period.

**INTERMEDIATE CONTRACT TIME NUMBER 3 AND LIQUIDATED DAMAGES:**

(2-20-07)

108

SP1 G14 A

The Contractor shall complete the required work of installing, maintaining, and removing the traffic control devices for lane closures and restoring traffic to the existing traffic pattern. The Contractor shall not close or narrow a lane of traffic on **Any Other Road** during the following time restrictions:

DAY AND TIME RESTRICTIONS

**Monday thru Sunday (Daily)**  
**5:00 A.M. to 9:00 P.M.**

In addition, the Contractor shall not close or narrow a lane of traffic on **Any Other Road**, detain and/or alter the traffic flow on or during holidays, holiday weekends, special events, or any other time when traffic is unusually heavy, including the following schedules:

HOLIDAY AND HOLIDAY WEEKEND LANE CLOSURE RESTRICTIONS

1. For **unexpected occurrence** that creates unusually high traffic volumes, as directed by the Engineer.
2. For **New Year's Day**, between the hours of **5:00 A.M.** December 31<sup>st</sup> and **9:00 P.M.** January 2<sup>nd</sup>. If New Year's Day is on a Friday, Saturday, Sunday or Monday, then until **9:00 P.M.** the following Tuesday.
3. For **Easter**, between the hours of **5:00 A.M.** Thursday and **9:00 P.M.** Monday.
4. For **Memorial Day**, between the hours of **5:00 A.M.** Friday and **9:00 P.M.** Tuesday.
5. For **Independence Day**, between the hours of **5:00 A.M.** the day before Independence Day and **9:00 P.M.** the day after Independence Day.

If **Independence Day** is on a Friday, Saturday, Sunday or Monday, then between the hours of **5:00 A.M.** the Thursday before Independence Day and **9:00 P.M.** the Tuesday after Independence Day.

6. For **Labor Day**, between the hours of **5:00 A.M.** Friday and **9:00 P.M.** Tuesday.
7. For **Thanksgiving**, between the hours of **5:00 A.M.** Tuesday and **9:00 P.M.** Monday.
8. For **Christmas**, between the hours of **5:00 A.M.** the Friday before the week of Christmas Day and **9:00 P.M.** the following Tuesday after the week of Christmas Day.

Holidays and holiday weekends shall include New Year's, Easter, Memorial Day, Independence Day, Labor Day, Thanksgiving, and Christmas. The Contractor shall schedule his work so that lane closures will not be required during these periods, unless otherwise directed by the Engineer.

The time of availability for this intermediate contract work shall be the time the Contractor begins to install all traffic control devices for lane closures according to the time restrictions listed herein.

The completion time for this intermediate contract work shall be the time the Contractor is required to complete the removal of all traffic control devices for lane closures according to the time restrictions stated above and place traffic in the existing traffic pattern.

The liquidated damages are **Five Hundred Dollars (\$ 500.00)** per fifteen (15) minute time period.

**INTERMEDIATE CONTRACT TIME NUMBER 4 AND LIQUIDATED DAMAGES:**

(2-20-07)

108

SP1 G14 D

The Contractor shall complete the required work of installing, maintaining and removing the traffic control devices for road closures and restoring traffic to the existing traffic pattern. The Contractor shall not close **I-40** during the following time restrictions:

**DAY AND TIME RESTRICTIONS**

**Monday thru Sunday (Daily)  
5:00 A.M. to 11:00 P.M.**

The time of availability for this intermediate contract time will be the time the Contractor begins to install traffic control devices required for road closures according to the time restrictions stated herein.

The completion time for this intermediate contract time will be the time the Contractor is required to complete the removal of traffic control devices required for the road closures according to the time restrictions stated herein and restore traffic to the existing traffic pattern

The liquidated damages are **Five Thousand Dollars (\$ 5,000.00)** per fifteen (15) minute time period.

**INTERMEDIATE CONTRACT TIME NUMBER 5 AND LIQUIDATED DAMAGES:**

(2-20-07)

108

SP1 G14 D

The Contractor shall complete the required work of installing, maintaining and removing the traffic control devices for road closures and restoring traffic to the existing traffic pattern. The Contractor shall not close **US-1** during the following time restrictions:

**DAY AND TIME RESTRICTIONS**

**Monday thru Sunday (Daily)  
5:00 A.M. to 11:00 P.M.**

The time of availability for this intermediate contract time will be the time the Contractor begins to install traffic control devices required for road closures according to the time restrictions stated herein.

The completion time for this intermediate contract time will be the time the Contractor is required to complete the removal of traffic control devices required for the road closures according to the time restrictions stated herein and restore traffic to the existing traffic pattern

The liquidated damages are **Two Thousand Five Hundred Dollars (\$ 2,500.00)** per fifteen (15) minute time period.

**INTERMEDIATE CONTRACT TIME NUMBER 6 AND LIQUIDATED DAMAGES:**

(2-20-07)

108

SP1 G14 D

The Contractor shall complete the required work of installing, maintaining and removing the traffic control devices for road closures and restoring traffic to the existing traffic pattern. The Contractor shall not close **Any Other Road** during the following time restrictions:

**DAY AND TIME RESTRICTIONS**

**Monday thru Sunday (Daily)  
5:00 A.M. to 9:00 P.M.**

The time of availability for this intermediate contract time will be the time the Contractor begins to install traffic control devices required for road closures according to the time restrictions stated herein.

The completion time for this intermediate contract time will be the time the Contractor is required to complete the removal of traffic control devices required for the road closures according to the time restrictions stated herein and restore traffic to the existing traffic pattern

The liquidated damages are **One Thousand Dollars (\$ 1,000.00)** per fifteen (15) minute time period.

**INTERMEDIATE CONTRACT TIME NUMBER 7 AND LIQUIDATED DAMAGES:**

(5-21-13)

108

SP1 G14 I

The Contractor shall complete the work required of installing each new inductive loop after the removal of each existing loop by the milling, patching or resurfacing operations and shall place and maintain traffic on same.

The date of availability for this intermediate contract time for each inductive loop installation will be the date when the Contractor elects to disturb the existing inductive loop.

The completion date for this intermediate contract time for each inductive loop installation will be the date which is seven (7) consecutive calendar days after the date of availability.

The liquidated damages are **Five Hundred Dollars (\$ 500.00)** per calendar day.

**MAJOR CONTRACT ITEMS:**

(2-19-02)

104

SP1 G28

The following listed items are the major contract items for this contract (see Article 104-5 of the *2018 Standard Specifications*):

<b>Line #</b>	<b>Description</b>
36	Foam Joint Seals for Preservation
38	Pourable Silicone Joint Sealant
39	Elastomeric Concrete for Preservation
41	Bridge Joint Demolition
48	Silane Deck Treatment

**SPECIALTY ITEMS:**

(7-1-95)(Rev. 7-20-21)

108-6

SP1 G37

Items listed below will be the specialty items for this contract (see Article 108-6 of the *2018 Standard Specifications*).

<b>Line #</b>	<b>Description</b>
16-20	Long-Life Pavement Markings
21	Permanent Pavement Markers
23-24	Signals/ITS System
25, 28-33	Bridge Painting

**FUEL PRICE ADJUSTMENT:**

(11-15-05) (Rev. 11-15-22)

109-8

SP1 G43

Revise the *2018 Standard Specifications* as follows:

**Page 1-87, Article 109-8, Fuel Price Adjustments**, add the following:

The base index price for DIESEL #2 FUEL is **\$ 2.6378** per gallon. Where any of the following are included as pay items in the contract, they will be eligible for fuel price adjustment.

The pay items and the fuel factor used in calculating adjustments to be made will be as follows:

Description	Units	Fuel Usage Factor Diesel
Unclassified Excavation	Gal/CY	0.29
Borrow Excavation	Gal/CY	0.29
Class IV Subgrade Stabilization	Gal/Ton	0.55
Aggregate Base Course	Gal/Ton	0.55
Sub-Ballast	Gal/Ton	0.55
Erosion Control Stone	Gal/Ton	0.55
Rip Rap, Class _____	Gal/Ton	0.55
Asphalt Concrete Base Course, Type _____	Gal/Ton	0.90 or 2.90
Asphalt Concrete Intermediate Course, Type _____	Gal/Ton	0.90 or 2.90
Asphalt Concrete Surface Course, Type _____	Gal/Ton	0.90 or 2.90
Open-Graded Asphalt Friction Course	Gal/Ton	0.90 or 2.90
Permeable Asphalt Drainage Course, Type _____	Gal/Ton	0.90 or 2.90
Sand Asphalt Surface Course, Type _____	Gal/Ton	0.90 or 2.90
Ultra-thin Bonded Wearing Course	Gal/Ton	0.90 or 2.90
Aggregate for Cement Treated Base Course	Gal/Ton	0.55
Portland Cement for Cement Treated Base Course	Gal/Ton	0.55
> 11" Portland Cement Concrete Pavement	Gal/SY	0.327
Concrete Shoulders Adjacent to > 11" Pavement	Gal/SY	0.327
9" to 11" Portland Cement Concrete Pavement	Gal/SY	0.272
Concrete Shoulders Adjacent to 9" to 11" Pavement	Gal/SY	0.272
< 9" Portland Cement Concrete Pavement	Gal/SY	0.245
Concrete Shoulders Adjacent to < 9" Pavement	Gal/SY	0.245

For the asphalt items noted in the chart as eligible for fuel adjustments, the bidder may include the *Fuel Usage Factor Adjustment Form* with their bid submission if they elect to use the fuel usage factor. The *Fuel Usage Factor Adjustment Form* is found at the following link:

<https://connect.ncdot.gov/letting/LetCentral/Fuel%20Usage%20Factor%20Adjustment%20Form%20-%20Starting%20Nov%202022%20Lettings.pdf>

Select either 2.90 Gal/Ton fuel factor or 0.90 Gal/Ton fuel factor for each asphalt line item on the *Fuel Usage Factor Adjustment Form*. The selected fuel factor for each asphalt item will remain in effect for the duration of the contract.

Failure to complete the *Fuel Usage Factor Adjustment Form* will result in using 2.90 gallons per ton as the Fuel Usage Factor for Diesel for the asphalt items noted above. The contractor will not be permitted to change the Fuel Usage Factor after the bids are submitted.

**SCHEDULE OF ESTIMATED COMPLETION PROGRESS:**

(7-15-08) (Rev. 6-20-23)

108-2

SP1 G58

The Contractor's attention is directed to the Standard Special Provision entitled *Availability of Funds Termination of Contracts* included elsewhere in this proposal. The Department of Transportation's schedule of estimated completion progress for this project as required by that Standard Special Provision is as follows:

<b><u>Fiscal Year</u></b>	<b><u>Progress (% of Dollar Value)</u></b>
2024	(7/01/23 - 6/30/24) <b>48%</b> of Total Amount Bid
2025	(7/01/24 - 6/30/25) <b>48%</b> of Total Amount Bid
2026	(7/01/25 - 6/30/26) <b>4%</b> of Total Amount Bid

The Contractor shall also furnish his own progress schedule in accordance with Article 108-2 of the *2018 Standard Specifications*. Any acceleration of the progress as shown by the Contractor's progress schedule over the progress as shown above shall be subject to the approval of the Engineer.

**MINORITY BUSINESS ENTERPRISE AND WOMEN BUSINESS ENTERPRISE:**

(10-16-07)(Rev. 8-17-21)

102-15(J)

SP1 G66

**Description**

The purpose of this Special Provision is to carry out the North Carolina Department of Transportation's policy of ensuring nondiscrimination in the award and administration of contracts financed in whole or in part with State funds.

**Definitions**

*Additional MBE/WBE Subcontractors* - Any MBE/WBE submitted at the time of bid that will not be used to meet the Combined MBE /WBE Goal. No submittal of a Letter of Intent is required.

*Combined MBE/WBE Goal*: A portion of the total contract, expressed as a percentage that is to be performed by committed MBE/WBE subcontractors.

*Committed MBE/WBE Subcontractor* - Any MBE/WBE submitted at the time of bid that is being used to meet the Combined MBE /WBE goal by submission of a Letter of Intent. Or any MBE or WBE used as a replacement for a previously committed MBE or WBE firm.

*Contract Goal Requirement* - The approved participation at time of award, but not greater than the advertised Combined MBE/WBE contract goal.

*Goal Confirmation Letter* - Written documentation from the Department to the bidder confirming the Contractor's approved, committed participation along with a listing of the committed MBE and WBE firms.

*Manufacturer* - A firm that operates or maintains a factory or establishment that produces on the premises, the materials or supplies obtained by the Contractor.

*MBE Participation (Anticipated)* - A portion of the total contract, expressed as a percentage that is anticipated to be performed by committed MBE subcontractor(s).

*Minority Business Enterprise (MBE)* - A firm certified as a Disadvantaged Minority-Owned Business Enterprise through the North Carolina Unified Certification Program.

*Regular Dealer* - A firm that owns, operates, or maintains a store, warehouse, or other establishment in which the materials or supplies required for the performance of the contract are bought, kept in stock, and regularly sold to the public in the usual course of business. A regular dealer engages in, as its principal business and in its own name, the purchase and sale or lease of the products in question. A regular dealer in such bulk items as steel, cement, gravel, stone, and petroleum products need not keep such products in stock, if it owns and operates distribution equipment for the products. Brokers and packagers are not regarded as manufacturers or regular dealers within the meaning of this section.

*Replacement / Substitution* – A full or partial reduction in the amount of work subcontracted to a committed (or an approved substitute) MBE/WBE firm.

*North Carolina Unified Certification Program (NCUCP)* - A program that provides comprehensive services and information to applicants for MBE/WBE certification. The MBE/WBE program follows the same regulations as the federal Disadvantaged Business Enterprise (DBE) program in accordance with 49 CFR Part 26.

*United States Department of Transportation (USDOT)* - Federal agency responsible for issuing regulations (49 CFR Part 26) and official guidance for the DBE program.

*WBE Participation (Anticipated)* - A portion of the total contract, expressed as a percentage, that is anticipated to be performed by committed WBE subcontractor(s).

*Women Business Enterprise (WBE)* - A firm certified as a Disadvantaged Women-Owned Business Enterprise through the North Carolina Unified Certification Program.

### **Forms and Websites Referenced in this Provision**

*Payment Tracking System* - On-line system in which the Contractor enters the payments made to MBE and WBE subcontractors who have performed work on the project.  
<https://apps.dot.state.nc.us/Vendor/PaymentTracking/>

*DBE-IS Subcontractor Payment Information* - Form for reporting the payments made to all MBE/WBE firms working on the project. This form is for paper bid projects only.  
<https://connect.ncdot.gov/business/Turnpike/Documents/Form%20DBE-IS%20Subcontractor%20Payment%20Information.pdf>

*RF-1 MBE/WBE Replacement Request Form* - Form for replacing a committed MBE or WBE.  
<http://connect.ncdot.gov/projects/construction/Construction%20Forms/DBE%20MBE%20WBE%20Replacement%20Request%20Form.pdf>

*SAF Subcontract Approval Form* - Form required for approval to sublet the contract.



<http://connect.ncdot.gov/projects/construction/Construction%20Forms/Subcontract%20Approval%20Form%20Rev.%202012.zip>

*JC-1 Joint Check Notification Form* - Form and procedures for joint check notification. The form acts as a written joint check agreement among the parties providing full and prompt disclosure of the expected use of joint checks.

<http://connect.ncdot.gov/projects/construction/Construction%20Forms/Joint%20Check%20Notification%20Form.pdf>

*Letter of Intent* - Form signed by the Contractor and the MBE/WBE subcontractor, manufacturer or regular dealer that affirms that a portion of said contract is going to be performed by the signed MBE/WBE for the estimated amount (based on quantities and unit prices) listed at the time of bid.

<http://connect.ncdot.gov/letting/LetCentral/Letter%20of%20Intent%20to%20Perform%20as%20a%20Subcontractor.pdf>

*Listing of MBE and WBE Subcontractors Form* - Form for entering MBE/WBE subcontractors on a project that will meet the Combined MBE/WBE goal. This form is for paper bids only.

[http://connect.ncdot.gov/municipalities/Bid%20Proposals%20for%20LGA%20Content/09%20MBE-WBE%20Subcontractors%20\(State\).docx](http://connect.ncdot.gov/municipalities/Bid%20Proposals%20for%20LGA%20Content/09%20MBE-WBE%20Subcontractors%20(State).docx)

*Subcontractor Quote Comparison Sheet* - Spreadsheet for showing all subcontractor quotes in the work areas where MBEs and WBEs quoted on the project. This sheet is submitted with good faith effort packages.

<http://connect.ncdot.gov/business/SmallBusiness/Documents/DBE%20Subcontractor%20Quote%20Comparison%20Example.xls>

### **Combined MBE/WBE Goal**

The Combined MBE/WBE Goal for this project is **1.0 %**

The Combined Goal was established utilizing the following anticipated participation for Minority Business Enterprises and Women Business Enterprises:

(A) Minority Business Enterprises **0.0 %**

- (1) *If the anticipated MBE participation is more than zero*, the Contractor shall exercise all necessary and reasonable steps to ensure that MBEs participate in at least the percent of the contract as set forth above.
- (2) *If the anticipated MBE participation is zero*, the Contractor shall make an effort to recruit and use MBEs during the performance of the contract. Any MBE participation obtained shall be reported to the Department.

(B) Women Business Enterprises **1.0 %**

- (1) *If the anticipated WBE participation is more than zero*, the Contractor shall exercise all necessary and reasonable steps to ensure that WBEs participate in at least the percent of the contract as set forth above.

- (2) *If the anticipated WBE participation is zero*, the Contractor shall make an effort to recruit and use WBEs during the performance of the contract. Any WBE participation obtained shall be reported to the Department.

The Bidder is required to submit only participation to meet the Combined MBE/WBE Goal. The Combined Goal may be met by submitting all MBE participation, all WBE participation, or a combination of MBE and WBE participation.

### **Directory of Transportation Firms (Directory)**

Real-time information is available about firms doing business with the Department and firms that are certified through NCUCP in the Directory of Transportation Firms. Only firms identified in the Directory as MBE and WBE certified shall be used to meet the Combined MBE/WBE Goal. The Directory can be found at the following link.

<https://www.ebs.nc.gov/VendorDirectory/default.html>

The listing of an individual firm in the directory shall not be construed as an endorsement of the firm's capability to perform certain work.

### **Listing of MBE/WBE Subcontractors**

At the time of bid, bidders shall submit all MBE and WBE participation that they anticipate to use during the life of the contract. Only those identified to meet the Combined MBE/WBE Goal will be considered committed, even though the listing shall include both committed MBE/WBE subcontractors and additional MBE/WBE subcontractors. Any additional MBE/WBE subcontractor participation above the goal will follow the banking guidelines found elsewhere in this provision. All other additional MBE/WBE subcontractor participation submitted at the time of bid will be used toward the Department's overall race-neutral goals. Only those firms with current MBE and WBE certification at the time of bid opening will be acceptable for listing in the bidder's submittal of MBE and WBE participation. The Contractor shall indicate the following required information:

#### **(A) Electronic Bids**

Bidders shall submit a listing of MBE and WBE participation in the appropriate section of the electronic submittal file.

- (1) Submit the names and addresses of MBE and WBE firms identified to participate in the contract. If the bidder uses the updated listing of MBE and WBE firms shown in the electronic submittal file, the bidder may use the dropdown menu to access the name and address of the firms.
- (2) Submit the contract line numbers of work to be performed by each MBE and WBE firm. When no figures or firms are entered, the bidder will be considered to have no MBE or WBE participation.

- (3) The bidder shall be responsible for ensuring that the MBE and WBE are certified at the time of bid by checking the Directory of Transportation Firms. If the firm is not certified at the time of the bid-letting, that MBE's or WBE's participation will not count towards achieving the Combined MBE/WBE goal.
- (B) Paper Bids
- (1) *If the Combined MBE/WBE Goal is more than zero,*
    - (a) Bidders, at the time the bid proposal is submitted, shall submit a listing of MBE/WBE participation, including the names and addresses on *Listing of MBE and WBE Subcontractors* contained elsewhere in the contract documents in order for the bid to be considered responsive. Bidders shall indicate the total dollar value of the MBE and WBE participation for the contract.
    - (b) If bidders have no MBE or WBE participation, they shall indicate this on the *Listing of MBE and WBE Subcontractors* by entering the word "None" or the number "0." This form shall be completed in its entirety. **Blank forms will not be deemed to represent zero participation.** Bids submitted that do not have MBE and WBE participation indicated on the appropriate form will not be read publicly during the opening of bids. The Department will not consider these bids for award and the proposal will be rejected.
    - (c) The bidder shall be responsible for ensuring that the MBE/WBE is certified at the time of bid by checking the Directory of Transportation Firms. If the firm is not certified at the time of the bid-letting, that MBE's or WBE's participation will not count towards achieving the Combined MBE/WBE Goal.
  - (2) *If the Combined MBE/WBE Goal is zero,* entries on the *Listing of MBE and WBE Subcontractors* are not required for the zero goal, however any MBE or WBE participation that is achieved during the project shall be reported in accordance with requirements contained elsewhere in the special provision.

### **MBE or WBE Prime Contractor**

When a certified MBE or WBE firm bids on a contract that contains a Combined MBE/WBE goal, the firm is responsible for meeting the goal or making good faith efforts to meet the goal, just like any other bidder. In most cases, a MBE or WBE bidder on a contract will meet the Combined MBE/WBE Goal by virtue of the work it performs on the contract with its own forces. However, all the work that is performed by the MBE or WBE bidder and any other similarly certified subcontractors will count toward the goal. The MBE or WBE bidder shall list itself along with any MBE or WBE subcontractors, if any, in order to receive credit toward the goal.

MBE/WBE prime contractors shall also follow Sections A and B listed under *Listing of MBE/WBE Subcontractor* just as a non-MBE/WBE bidder would.

**Written Documentation – Letter of Intent**

The bidder shall submit written documentation for each MBE/WBE that will be used to meet the Combined MBE/WBE Goal of the contract, indicating the bidder's commitment to use the MBE/WBE in the contract. This documentation shall be submitted on the Department's form titled *Letter of Intent*.

The documentation shall be received in the office of the State Contractor Utilization Engineer or at DBE@ncdot.gov no later than 10:00 a.m. of the sixth calendar day following opening of bids, unless the sixth day falls on an official state holiday. In that situation, it is due in the office of the State Contractor Utilization Engineer no later than 10:00 a.m. on the next official state business day.

If the bidder fails to submit the Letter of Intent from each committed MBE and WBE to be used toward the Combined MBE/WBE Goal, or if the form is incomplete (i.e. both signatures are not present), the MBE/WBE participation will not count toward meeting the Combined MBE/WBE Goal. If the lack of this participation drops the commitment below the Combined MBE/WBE Goal, the Contractor shall submit evidence of good faith efforts for the goal, completed in its entirety, to the State Contractor Utilization Engineer or DBE@ncdot.gov no later than 10:00 a.m. on the eighth calendar day following opening of bids, unless the eighth day falls on an official state holiday. In that situation, it is due in the office of the State Contractor Utilization Engineer no later than 10:00 a.m. on the next official state business day.

**Banking MBE/WBE Credit**

If the bid of the lowest responsive bidder exceeds \$500,000 and if the committed MBE/WBE participation submitted exceeds the algebraic sum of the Combined MBE /WBE Goal by \$1,000 or more, the excess will be placed on deposit by the Department for future use by the bidder. Separate accounts will be maintained for MBE and WBE participation and these may accumulate for a period not to exceed 24 months.

When the apparent lowest responsive bidder fails to submit sufficient participation by MBE and WBE firms to meet the advertised goal, as part of the good faith effort, the Department will consider allowing the bidder to withdraw funds to meet the Combined MBE/WBE Goal as long as there are adequate funds available from the bidder's MBE and WBE bank accounts.

**Submission of Good Faith Effort**

If the bidder fails to meet or exceed the Combined MBE/WBE Goal, the apparent lowest responsive bidder shall submit to the Department documentation of adequate good faith efforts made to reach that specific goal.

A hard copy and an electronic copy of this information shall be received in the office of the State Contractor Utilization Engineer or at DBE@ncdot.gov no later than 10:00 a.m. on the sixth calendar day following opening of bids unless the sixth day falls on an official state holiday. In that situation, it would be due in the office of the State Contractor Utilization Engineer no later than 10:00 a.m. on the next official state business day. If the contractor cannot send the information

electronically, then one complete set and 5 copies of this information shall be received under the same time constraints above.

Note: Where the information submitted includes repetitious solicitation letters, it will be acceptable to submit a representative letter along with a distribution list of the firms that were solicited. Documentation of MBE/WBE quotations shall be a part of the good faith effort submittal. This documentation may include written subcontractor quotations, telephone log notations of verbal quotations, or other types of quotation documentation.

### **Consideration of Good Faith Effort for Projects with a Combined MBE/WBE Goal More Than Zero**

Adequate good faith efforts mean that the bidder took all necessary and reasonable steps to achieve the goal which, by their scope, intensity, and appropriateness, could reasonably be expected to obtain sufficient MBE/WBE participation. Adequate good faith efforts also mean that the bidder actively and aggressively sought MBE/WBE participation. Mere *pro forma* efforts are not considered good faith efforts.

The Department will consider the quality, quantity, and intensity of the different kinds of efforts a bidder has made. Listed below are examples of the types of actions a bidder will take in making a good faith effort to meet the goals and are not intended to be exclusive or exhaustive, nor is it intended to be a mandatory checklist.

- (A) Soliciting through all reasonable and available means (e.g. attendance at pre-bid meetings, advertising, written notices, use of verifiable electronic means through the use of the NCDOT Directory of Transportation Firms) the interest of all certified MBEs/WBEs that are also prequalified subcontractors. The bidder must solicit this interest within at least 10 days prior to bid opening to allow the MBEs/WBEs to respond to the solicitation. Solicitation shall provide the opportunity to MBEs/WBEs within the Division and surrounding Divisions where the project is located. The bidder must determine with certainty if the MBEs/WBEs are interested by taking appropriate steps to follow up initial solicitations.
- (B) Selecting portions of the work to be performed by MBEs/WBEs in order to increase the likelihood that the Combined MBE/WBE Goal will be achieved.
  - (1) Where appropriate, break out contract work items into economically feasible units to facilitate MBE/WBE participation, even when the prime contractor might otherwise prefer to perform these work items with its own forces.
  - (2) Negotiate with subcontractors to assume part of the responsibility to meet the advertised goal when the work to be sublet includes potential for MBE/WBE participation (2<sup>nd</sup> and 3<sup>rd</sup> tier subcontractors).
- (C) Providing interested certified MBEs/WBEs that are also prequalified subcontractors with adequate information about the plans, specifications, and requirements of the contract in a timely manner to assist them in responding to a solicitation.

- (D) (1) Negotiating in good faith with interested MBEs/WBEs. It is the bidder's responsibility to make a portion of the work available to MBE/WBE subcontractors and suppliers and to select those portions of the work or material needs consistent with the available MBE/WBE subcontractors and suppliers, so as to facilitate MBE/WBE participation. Evidence of such negotiation includes the names, addresses, and telephone numbers of MBEs/WBEs that were considered; a description of the information provided regarding the plans and specifications for the work selected for subcontracting; and evidence as to why additional agreements could not be reached for MBEs/WBEs to perform the work.
- (2) A bidder using good business judgment would consider a number of factors in negotiating with subcontractors, including MBE/WBE subcontractors, and would take a firm's price and capabilities as well as the advertised goal into consideration. However, the fact that there may be some additional costs involved in finding and using MBEs/WBEs is not in itself sufficient reason for a bidder's failure to meet the contract goal, as long as such costs are reasonable. Also, the ability or desire of a prime contractor to perform the work of a contract with its own organization does not relieve the bidder of the responsibility to make good faith efforts. Bidding contractors are not, however, required to accept higher quotes from MBEs/WBEs if the price difference is excessive or unreasonable.
- (E) Not rejecting MBEs/WBEs as being unqualified without sound reasons based on a thorough investigation of their capabilities. The bidder's standing within its industry, membership in specific groups, organizations, or associates and political or social affiliations (for example, union vs. non-union employee status) are not legitimate causes for the rejection or non-solicitation of bids in the bidder's efforts to meet the project goal.
- (F) Making efforts to assist interested MBEs/WBEs in obtaining bonding, lines of credit, or insurance as required by the recipient or bidder.
- (G) Making efforts to assist interested MBEs/WBEs in obtaining necessary equipment, supplies, materials, or related assistance or services.
- (H) Effectively using the services of available minority/women community organizations; minority/women contractors' groups; Federal, State, and local minority/women business assistance offices; and other organizations as allowed on a case-by-case basis to provide assistance in the recruitment and placement of MBEs/WBEs. Contact within 7 days from the bid opening the Business Opportunity and Work Force Development Unit at [BOWD@ncdot.gov](mailto:BOWD@ncdot.gov) to give notification of the bidder's inability to get MBE or WBE quotes.
- (I) Any other evidence that the bidder submits which shows that the bidder has made reasonable good faith efforts to meet the advertised goal.

In addition, the Department may take into account the following:

- (1) Whether the bidder's documentation reflects a clear and realistic plan for achieving the Combined MBE/WBE Goal.

- (2) The bidders' past performance in meeting the contract goal.
- (3) The performance of other bidders in meeting the advertised goal. For example, when the apparent successful bidder fails to meet the goal, but others meet it, you may reasonably raise the question of whether, with additional reasonable efforts the apparent successful bidder could have met the goal. If the apparent successful bidder fails to meet the advertised goal, but meets or exceeds the average MBE and WBE participation obtained by other bidders, the Department may view this, in conjunction with other factors, as evidence of the apparent successful bidder having made a good faith effort.

If the Department does not award the contract to the apparent lowest responsive bidder, the Department reserves the right to award the contract to the next lowest responsive bidder that can satisfy to the Department that the Combined MBE/WBE Goal can be met or that an adequate good faith effort has been made to meet the advertised goal.

### **Non-Good Faith Appeal**

The State Prequalification Engineer will notify the contractor verbally and in writing of non-good faith. A contractor may appeal a determination of non-good faith made by the Goal Compliance Committee. If a contractor wishes to appeal the determination made by the Committee, they shall provide written notification to the State Prequalification Engineer or at [DBE@ncdot.gov](mailto:DBE@ncdot.gov). The appeal shall be made within 2 business days of notification of the determination of non-good faith.

### **Counting MBE/WBE Participation Toward Meeting the Combined MBE/WBE Goal**

#### **(A) Participation**

The total dollar value of the participation by a committed MBE/WBE will be counted toward the contract goal requirements. The total dollar value of participation by a committed MBE/WBE will be based upon the value of work actually performed by the MBE/WBE and the actual payments to MBE/WBE firms by the Contractor.

#### **(B) Joint Checks**

Prior notification of joint check use shall be required when counting MBE/WBE participation for services or purchases that involves the use of a joint check. Notification shall be through submission of Form JC-1 (*Joint Check Notification Form*) and the use of joint checks shall be in accordance with the Department's Joint Check Procedures.

#### **(C) Subcontracts (Non-Trucking)**

A MBE/WBE may enter into subcontracts. Work that a MBE subcontracts to another MBE firm may be counted toward the anticipated MBE participation. The same holds true for work that a WBE subcontracts to another WBE firm. Work that a MBE/WBE subcontracts to a non-MBE/WBE firm does not count toward the contract goal requirement. It should

be noted that every effort shall be made by MBE and WBE contractors to subcontract to the same certification (i.e., MBEs to MBEs and WBEs to WBEs), in order to fulfill the MBE or WBE participation breakdown. This, however, may not always be possible due to the limitation of firms in the area. If the MBE or WBE firm shows a good faith effort has been made to reach out to similarly certified firms and there is no interest or availability, and they can get assistance from other certified firms, the Engineer will not hold the prime responsible for meeting the individual MBE or WBE breakdown. If a MBE or WBE contractor or subcontractor subcontracts a significantly greater portion of the work of the contract than would be expected on the basis of standard industry practices, it shall be presumed that the MBE or WBE is not performing a commercially useful function.

(D) Joint Venture

When a MBE or WBE performs as a participant in a joint venture, the Contractor may count toward its contract goal requirement a portion of the total value of participation with the MBE or WBE in the joint venture, that portion of the total dollar value being a distinct clearly defined portion of work that the MBE or WBE performs with its forces.

(E) Suppliers

A contractor may count toward its MBE/ WBE requirement 60 percent of its expenditures for materials and supplies required to complete the contract and obtained from a MBE or WBE regular dealer and 100 percent of such expenditures from a MBE or WBE manufacturer.

(F) Manufacturers and Regular Dealers

A contractor may count toward its MBE/ WBE requirement the following expenditures to MBE/WBE firms that are not manufacturers or regular dealers:

- (1) The fees or commissions charged by a MBE/WBE firm for providing a *bona fide* service, such as professional, technical, consultant, or managerial services, or for providing bonds or insurance specifically required for the performance of a DOT-assisted contract, provided the fees or commissions are determined to be reasonable and not excessive as compared with fees and commissions customarily allowed for similar services.
- (2) With respect to materials or supplies purchased from a MBE/WBE, which is neither a manufacturer nor a regular dealer, count the entire amount of fees or commissions charged for assistance in the procurement of the materials and supplies, or fees or transportation charges for the delivery of materials or supplies required on a job site (but not the cost of the materials and supplies themselves), provided the fees are determined to be reasonable and not excessive as compared with fees customarily allowed for similar services.



**Commercially Useful Function****(A) MBE/WBE Utilization**

The Contractor may count toward its contract goal requirement only expenditures to MBEs and WBEs that perform a commercially useful function in the work of a contract. A MBE/WBE performs a commercially useful function when it is responsible for execution of the work of the contract and is carrying out its responsibilities by actually performing, managing, and supervising the work involved. To perform a commercially useful function, the MBE/WBE shall also be responsible with respect to materials and supplies used on the contract, for negotiating price, determining quality and quantity, ordering the material and installing (where applicable) and paying for the material itself. To determine whether a MBE/WBE is performing a commercially useful function, the Department will evaluate the amount of work subcontracted, industry practices, whether the amount the firm is to be paid under the contract is commensurate with the work it is actually performing and the MBE/WBE credit claimed for its performance of the work, and any other relevant factors. If it is determined that a MBE or WBE is not performing a Commercially Useful Function, the contractor may present evidence to rebut this presumption to the Department.

**(B) MBE/WBE Utilization in Trucking**

The following factors will be used to determine if a MBE or WBE trucking firm is performing a commercially useful function:

- (1) The MBE/WBE shall be responsible for the management and supervision of the entire trucking operation for which it is responsible on a particular contract, and there shall not be a contrived arrangement for the purpose of meeting the Combined MBE/WBE Goal.
- (2) The MBE/WBE shall itself own and operate at least one fully licensed, insured, and operational truck used on the contract.
- (3) The MBE/WBE receives credit for the total value of the transportation services it provides on the contract using trucks it owns, insures, and operates using drivers it employs.
- (4) The MBE may subcontract the work to another MBE firm, including an owner-operator who is certified as a MBE. The same holds true that a WBE may subcontract the work to another WBE firm, including an owner-operator who is certified as a WBE. When this occurs, the MBE or WBE who subcontracts work receives credit for the total value of the transportation services the subcontracted MBE or WBE provides on the contract. It should be noted that every effort shall be made by MBE and WBE contractors to subcontract to the same certification (i.e., MBEs to MBEs and WBEs to WBEs), in order to fulfill the participation breakdown. This, however, may not always be possible due to the limitation of firms in the area. If the MBE or WBE firm shows a good faith effort has been made

to reach out to similarly certified transportation service providers and there is no interest or availability, and they can get assistance from other certified providers, the Engineer will not hold the prime responsible for meeting the individual MBE or WBE participation breakdown.

- (5) The MBE/WBE may also subcontract the work to a non-MBE/WBE firm, including from an owner-operator. The MBE/WBE who subcontracts the work to a non-MBE/WBE is entitled to credit for the total value of transportation services provided by the non-MBE/WBE subcontractor not to exceed the value of transportation services provided by MBE/WBE-owned trucks on the contract. Additional participation by non-MBE/WBE subcontractors receives credit only for the fee or commission it receives as a result of the subcontract arrangement. The value of services performed under subcontract agreements between the MBE/WBE and the Contractor will not count towards the MBE/WBE contract requirement.
- (6) A MBE/WBE may lease truck(s) from an established equipment leasing business open to the general public. The lease must indicate that the MBE/WBE has exclusive use of and control over the truck. This requirement does not preclude the leased truck from working for others during the term of the lease with the consent of the MBE/WBE, so long as the lease gives the MBE/WBE absolute priority for use of the leased truck. This type of lease may count toward the MBE/WBE's credit as long as the driver is under the MBE/WBE's payroll.
- (7) Subcontracted/leased trucks shall display clearly on the dashboard the name of the MBE/WBE that they are subcontracted/leased to and their own company name if it is not identified on the truck itself. Magnetic door signs are not permitted.

### **MBE/WBE Replacement**

When a Contractor has relied on a commitment to a MBE or WBE subcontractor (or an approved substitute MBE or WBE subcontractor) to meet all or part of a contract goal requirement, the contractor shall not terminate the MBE/WBE subcontractor for convenience. This includes, but is not limited to, instances in which the Contractor seeks to perform the work of the terminated subcontractor with another MBE/WBE subcontractor, a non-MBE/WBE subcontractor, or with the Contractor's own forces or those of an affiliate.

The Contractor must give notice in writing both by certified mail and email to the MBE/WBE subcontractor, with a copy to the Engineer of its intent to request to terminate and/or substitute, and the reason for the request. The Contractor must give the MBE/WBE subcontractor five (5) business days to respond to the Contractor's Notice of Intent to Request Termination and/or Substitution. If the MBE/WBE subcontractor objects to the intended termination/substitution, the MBE/WBE, within five (5) business days must advise the Contractor and the Department of the reasons why the action should not be approved. The five-day notice period shall begin on the next business day after written notice is provided to the MBE/WBE subcontractor.

A committed MBE/WBE subcontractor may only be terminated after receiving the Department's written approval based upon a finding of good cause for the proposed termination and/or substitution. For purposes of this section, good cause shall include the following circumstances:

- (a) The listed MBE/WBE subcontractor fails or refuses to execute a written contract;
- (b) The listed MBE/WBE subcontractor fails or refuses to perform the work of its subcontract in a way consistent with normal industry standards. Provided, however, that good cause does not exist if the failure or refusal of the MBE/WBE subcontractor to perform its work on the subcontract results from the bad faith or discriminatory action of the prime contractor;
- (c) The listed MBE/WBE subcontractor fails or refuses to meet the prime contractor's reasonable, nondiscriminatory bond requirements;
- (d) The listed MBE/WBE subcontractor becomes bankrupt, insolvent, or exhibits credit unworthiness;
- (e) The listed MBE/WBE subcontractor is ineligible to work on public works projects because of suspension and debarment proceedings pursuant to 2 CFR Parts 180, 215 and 1,200 or applicable state law;
- (f) The listed MBE/WBE subcontractor is not a responsible contractor;
- (g) The listed MBE/WBE voluntarily withdraws from the project and provides written notice of withdrawal;
- (h) The listed MBE/WBE is ineligible to receive MBE/WBE credit for the type of work required;
- (i) A MBE/WBE owner dies or becomes disabled with the result that the listed MBE/WBE contractor is unable to complete its work on the contract;
- (j) Other documented good cause that compels the termination of the MBE/WBE subcontractor. Provided, that good cause does not exist if the prime contractor seeks to terminate a MBE/WBE it relied upon to obtain the contract so that the prime contractor can self-perform the work for which the MBE/WBE contractor was engaged or so that the prime contractor can substitute another MBE/WBE or non-MBE/WBE contractor after contract award.

The Contractor shall comply with the following for replacement of a committed MBE/WBE:

(A) Performance Related Replacement

When a committed MBE/WBE is terminated for good cause as stated above, an additional MBE/WBE that was submitted at the time of bid may be used to fulfill the MBE/WBE commitment to meet the Combined MBE/WBE Goal. A good faith effort will only be required for removing a committed MBE/WBE if there were no additional MBE/WBEs submitted at the time of bid to cover the same amount of work as the MBE/WBE that was terminated.

If a replacement MBE/WBE is not found that can perform at least the same amount of work as the terminated MBE/WBE, the Contractor shall submit a good faith effort documenting the steps taken. Such documentation shall include, but not be limited to, the following:

- (1) Copies of written notification to MBE/WBEs that their interest is solicited in contracting the work defaulted by the previous MBE/WBE or in subcontracting other items of work in the contract.
- (2) Efforts to negotiate with MBE/WBEs for specific subbids including, at a minimum:

- (a) The names, addresses, and telephone numbers of MBE/WBEs who were contacted.
    - (b) A description of the information provided to MBE/WBEs regarding the plans and specifications for portions of the work to be performed.
  - (3) A list of reasons why MBE/WBE quotes were not accepted.
  - (4) Efforts made to assist the MBE/WBEs contacted, if needed, in obtaining bonding or insurance required by the Contractor.
- (B) Decertification Replacement
- (1) When a committed MBE/WBE is decertified by the Department after the SAF (*Subcontract Approval Form*) has been received by the Department, the Department will not require the Contractor to solicit replacement MBE/WBE participation equal to the remaining work to be performed by the decertified firm. The participation equal to the remaining work performed by the decertified firm will count toward the contract goal requirement.
  - (2) When a committed MBE/WBE is decertified prior to the Department receiving the SAF (*Subcontract Approval Form*) for the named MBE/WBE firm, the Contractor shall take all necessary and reasonable steps to replace the MBE/WBE subcontractor with another MBE/WBE subcontractor to perform at least the same amount of work to meet the Combined MBE/WBE goal requirement. If a MBE/WBE firm is not found to do the same amount of work, a good faith effort must be submitted to NCDOT (see A herein for required documentation).
  - (3) Exception: If the MBE/WBE's ineligibility is caused solely by its having exceeded the size standard during the performance of the contract, the Department will not require the Contractor to solicit replacement MBE/WBE participation equal to the remaining work to be performed by the decertified firm. The participation equal to the remaining work performed by the decertified firm will count toward the contract goal requirement and overall goal.

All requests for replacement of a committed MBE/WBE firm shall be submitted to the Engineer for approval on Form RF-1 (*DBE Replacement Request*). If the Contractor fails to follow this procedure, the Contractor may be disqualified from further bidding for a period of up to 6 months.

### **Changes in the Work**

When the Engineer makes changes that result in the reduction or elimination of work to be performed by a committed MBE/WBE, the Contractor will not be required to seek additional participation. When the Engineer makes changes that result in additional work to be performed by a MBE/WBE based upon the Contractor's commitment, the MBE/WBE shall participate in additional work to the same extent as the MBE/WBE participated in the original contract work.

When the Engineer makes changes that result in extra work, which has more than a minimal impact on the contract amount, the Contractor shall seek additional participation by MBEs/WBEs unless otherwise approved by the Engineer.

When the Engineer makes changes that result in an alteration of plans or details of construction, and a portion or all of the work had been expected to be performed by a committed MBE/WBE, the Contractor shall seek participation by MBEs/WBEs unless otherwise approved by the Engineer.

When the Contractor requests changes in the work that result in the reduction or elimination of work that the Contractor committed to be performed by a MBE/WBE, the Contractor shall seek additional participation by MBEs/WBEs equal to the reduced MBE/WBE participation caused by the changes.

### **Reports and Documentation**

A SAF (*Subcontract Approval Form*) shall be submitted for all work which is to be performed by a MBE/WBE subcontractor. The Department reserves the right to require copies of actual subcontract agreements involving MBE/WBE subcontractors.

When using transportation services to meet the contract commitment, the Contractor shall submit a proposed trucking plan in addition to the SAF. The plan shall be submitted prior to beginning construction on the project. The plan shall include the names of all trucking firms proposed for use, their certification type(s), the number of trucks owned by the firm, as well as the individual truck identification numbers, and the line item(s) being performed.

Within 30 calendar days of entering into an agreement with a MBE/WBE for materials, supplies or services, not otherwise documented by the SAF as specified above, the Contractor shall furnish the Engineer a copy of the agreement. The documentation shall also indicate the percentage (60% or 100%) of expenditures claimed for MBE/WBE credit.

### **Reporting Minority and Women Business Enterprise Participation**

The Contractor shall provide the Engineer with an accounting of payments made to all MBE/WBE firms, including material suppliers and contractors at all levels (prime, subcontractor, or second tier subcontractor). This accounting shall be furnished to the Engineer for any given month by the end of the following month. Failure to submit this information accordingly may result in the following action:

- (A) Withholding of money due in the next partial pay estimate; or
- (B) Removal of an approved contractor from the prequalified bidders' list or the removal of other entities from the approved subcontractors list.

While each contractor (prime, subcontractor, 2nd tier subcontractor) is responsible for accurate accounting of payments to MBEs/WBEs, it shall be the prime contractor's responsibility to report all monthly and final payment information in the correct reporting manner.

Failure on the part of the Contractor to submit the required information in the time frame specified may result in the disqualification of that contractor and any affiliate companies from further bidding until the required information is submitted.

Failure on the part of any subcontractor to submit the required information in the time frame specified may result in the disqualification of that contractor and any affiliate companies from being approved for work on future DOT projects until the required information is submitted.

Contractors reporting transportation services provided by non-MBE/WBE lessees shall evaluate the value of services provided during the month of the reporting period only.

At any time, the Engineer can request written verification of subcontractor payments.

The Contractor shall report the accounting of payments through the Department's Payment Tracking System.

### **Failure to Meet Contract Requirements**

Failure to meet contract requirements in accordance with Subarticle 102-15(J) of the *2018 Standard Specifications* may be cause to disqualify the Contractor.

### **CONTRACTOR'S LICENSE REQUIREMENTS:**

(7-1-95)

102-14

SP1 G88

If the successful bidder does not hold the proper license to perform any plumbing, heating, air conditioning, or electrical work in this contract, he will be required to sublet such work to a contractor properly licensed in accordance with *Article 2 of Chapter 87 of the General Statutes* (licensing of heating, plumbing, and air conditioning contractors) and *Article 4 of Chapter 87 of the General Statutes* (licensing of electrical contractors).

### **RESTRICTIONS ON ITS EQUIPMENT AND SERVICES:**

(11-17-20)

SP01 G090

All telecommunications, video or other ITS equipment or services installed or utilized on this project must be in conformance with UNIFORM ADMINISTRATIVE REQUIREMENTS, COST PRINCIPLES, AND AUDIT REQUIREMENTS FOR FEDERAL AWARDS **2 CFR, § 200.216** **Prohibition on certain telecommunications and video surveillance services or equipment.**

### **USE OF UNMANNED AIRCRAFT SYSTEM (UAS):**

(8-20-19)

SP1 G092

The Contractor shall adhere to all Federal, State and Local regulations and guidelines for the use of Unmanned Aircraft Systems (UAS). This includes but is not limited to US 14 CFR Part 107 *Small UAS Rule*, NC GS 15A-300.2 *Regulation of launch and recovery sites*, NC GS 63-95 *Training required for the operation of unmanned aircraft systems*, NC GS 63-96 *Permit required for commercial operation of unmanned aircraft system*, and NCDOT UAS Policy. The required operator certifications include possessing a current Federal Aviation Administration (FAA) Remote Pilot Certificate, a NC UAS Operator Permit as well as operating a UAS registered with the FAA.

Prior to beginning operations, the Contractor shall complete the NCDOT UAS – Flight Operation Approval Form and submit it to the Engineer for approval. All UAS operations shall be approved by the Engineer prior to beginning the operations.

All contractors or subcontractors operating UAS shall have UAS specific general liability insurance to cover all operations under this contract.

The use of UAS is at the Contractor's discretion. No measurement or payment will be made for the use of UAS. In the event that the Department directs the Contractor to utilize UAS, payment will be in accordance with Article 104-7 Extra Work.

**EQUIPMENT IDLING GUIDELINES:**

(1-19-21)

107

SP1 G096

Exercise reduced fuel consumption and reduced equipment emissions during the construction of all work associated with this contract. Employees engaged in the construction of this project should turn off vehicles when stopped for more than thirty (30) minutes and off-highway equipment should idle no longer than fifteen (15) consecutive minutes.

These guidelines for turning off vehicles and equipment when idling do not apply to:

1. Idling when queuing.
  2. Idling to verify the vehicle is in safe operating condition.
  3. Idling for testing, servicing, repairing or diagnostic purposes.
  4. Idling necessary to accomplish work for which the vehicle was designed (such as operating a crane, mixing concrete, etc.).
  5. Idling required to bring the machine system to operating temperature.
  6. Emergency vehicles, utility company, construction, and maintenance vehicles where the engines must run to perform needed work.
  7. Idling to ensure safe operation of the vehicle.
  8. Idling when the propulsion engine is providing auxiliary power for other than heating or air conditioning. (such as hydraulic systems for pavers)
  9. When specific traffic, safety, or emergency situations arise.
  10. If the ambient temperature is less than 32 degrees Fahrenheit. Limited idling to provide for the safety of vehicle occupants (e.g. to run the heater).
  11. If the ambient temperature is greater than 90 degrees Fahrenheit. Limited idling to provide for the safety of vehicle occupants of off-highway equipment (e.g. to run the air conditioning) no more than 30 minutes.
  12. Diesel powered vehicles may idle for up to 30 minutes to minimize restart problems.
- Any vehicle, truck, or equipment in which the primary source of fuel is natural gas or electricity is exempt from the idling limitations set forth in this special provision.

**ELECTRONIC BIDDING:**

(2-19-19)

101, 102, 103

SP1 G140

Revise the *2018 Standard Specifications* as follows:

**Page 1-4, Article 101-3, DEFINITIONS, BID (OR PROPOSAL) *Electronic Bid*, line 1,** replace “Bid Express®” with “the approved electronic bidding provider”.

**Page 1-15, Subarticle 102-8(B), Electronic Bids, lines 39-40,** replace “to Bid Express®” with “via the approved electronic bidding provider”.

**Page 1-15, Subarticle 102-8(B)(1), Electronic Bids, line 41,** delete “from Bid Express®”

**Page 1-17, Subarticle 102-9(C)(2), Electronic Bids, line 21,** replace “Bid Express® miscellaneous folder within the .ebs” with “electronic submittal”.

**Page 1-29, Subarticle 103-4(C)(2), Electronic Bids, line 32,** replace “.ebs miscellaneous data file of Expedite” with “electronic submittal file”

**AWARD LIMITS:**

(4-19-22)

103

SP1 G141

Revise the *2018 Standard Specifications* as follows:

**Page 1-29, Subarticle 103-4(C), Award Limits, line 4-8,** delete and replace the first sentence in the first paragraph with the following:

A bidder who desires to bid on more than one project on which bids are to be opened in the same letting and who desires to avoid receiving an award of more projects than he is equipped to handle, may bid on any number of projects but may limit the total amount of work awarded to him on selected projects by completing the form Award Limits on Multiple Projects for each project subject to the award limit.

**TWELVE MONTH GUARANTEE:**

(7-15-03)

108

SP1 G145

- (A) The Contractor shall guarantee materials and workmanship against latent and patent defects arising from faulty materials, faulty workmanship or negligence for a period of twelve months following the date of final acceptance of the work for maintenance and shall replace such defective materials and workmanship without cost to the Department. The Contractor will not be responsible for damage due to faulty design, normal wear and tear, for negligence on the part of the Department, and/or for use in excess of the design.
- (B) Where items of equipment or material carry a manufacturer’s guarantee for any period in excess of twelve months, then the manufacturer’s guarantee shall apply for that particular piece of equipment or material. The Department’s first remedy shall be through the manufacturer although the Contractor is responsible for invoking the warranted repair work with the manufacturer. The Contractor’s responsibility shall be limited to the term of the manufacturer’s guarantee. NCDOT would be afforded the same warranty as provided by the Manufacturer.



This guarantee provision shall be invoked only for major components of work in which the Contractor would be wholly responsible for under the terms of the contract. Examples would include pavement structures, bridge components, and sign structures. This provision will not be used as a mechanism to force the Contractor to return to the project to make repairs or perform additional work that the Department would normally compensate the Contractor for. In addition, routine maintenance activities (i.e. mowing grass, debris removal, ruts in earth shoulders,) are not parts of this guarantee.

Appropriate provisions of the payment and/or performance bonds shall cover this guarantee for the project.

To ensure uniform application statewide the Division Engineer will forward details regarding the circumstances surrounding any proposed guarantee repairs to the Chief Engineer for review and approval prior to the work being performed.

**OUTSOURCING OUTSIDE THE USA:**

(9-21-04) (Rev. 5-16-06)

SP1 G150

All work on consultant contracts, services contracts, and construction contracts shall be performed in the United States of America. No work shall be outsourced outside of the United States of America.

*Outsourcing* for the purpose of this provision is defined as the practice of subcontracting labor, work, services, staffing, or personnel to entities located outside of the United States.

The North Carolina Secretary of Transportation shall approve exceptions to this provision in writing.

**NOTE TO CONTRACTOR:**

Any concrete waste water shall be disposed of in accordance with the Department of Environmental Quality General Permit NCG01.

**PROJECT SPECIAL PROVISIONS****ROADWAY****BURNING RESTRICTIONS:**

(7-1-95)

200, 210, 215

SP2 R05

Open burning is not permitted on any portion of the right-of-way limits established for this project. Do not burn the clearing, grubbing or demolition debris designated for disposal and generated from the project at locations within the project limits, off the project limits or at any waste or borrow sites in this county. Dispose of the clearing, grubbing and demolition debris by means other than burning, according to state or local rules and regulations.

**INCIDENTAL MILLING:**

(11-15-22)(Rev. 1-17-23)

607

SP6 R02R

Revise the *2018 Standard Specifications* as follows:

**Page 6-5, Article 607-3 CONSTRUCTION METHODS**, add the following paragraph after line 45:

Variable depth milling is intended to improve the cross-sectional slope of the pavement.

**Page 6-6, Article 607-3 CONSTRUCTION METHODS, line 9**, delete and replace the first sentence in the sixth paragraph with the following:

The Engineer may require re-milling of any area exhibiting pavement laminations, scabbing or other defects.

**Page 6-6, Article 607-4 TOLERANCE, lines 17-18**, delete and replace the second sentence with the following:

The Engineer may vary the depth of milling by not more than one inch. In the event the directed depth of milling cut is altered by the Engineer more than one inch, either the Department or the Contractor may request an adjustment in unit price in accordance with Article 104-3. In administering Article 104-3, the Department will give no consideration to value given to RAP due to the deletion or reduction in quantity of milling. Article 104-3 will not apply to the item of *Incidental Milling*.

**Page 6-6, Subarticle 607-5(A) Milled Asphalt Pavement, lines 21-23**, delete and replace the first sentence with the following:

Milled Asphalt Pavement, \_\_\_" Depth will be measured and paid as the actual number of square yards of pavement surface milled in accordance with this specification.

**Page 6-6, Subarticle 607-5(A) Milled Asphalt Pavement, lines 24-28**, delete and replace the third and fourth sentence with the following:

The width will be the width required by the plans or directed by the Engineer, measured along the pavement surface. Areas to be paid under this item include mainline travel lanes, full width turn lanes greater than 500 feet in length, collector lanes, shoulders, and any additional equipment necessary to remove pavement in the area of manholes, water valves, curb, gutter and other obstructions.

**Page 6-6, Subarticle 607-5(B) Milled Asphalt Pavement Depth Varies from Required Depth, lines 29-37,** delete and replace the title and first paragraph with the following:

**(B) Variable Depth Milled Asphalt Pavement**

*Milling Asphalt Pavement, \_\_\_" to \_\_\_"* will be measured and paid as the actual number of square yards of pavement surface milled in accordance with this specification. In measuring this quantity, the length will be the actual length milled, measured along the pavement surface. The width will be the width required by the plans or directed by the Engineer, measured along the pavement surface. Areas to be paid under this item include mainline travel lanes, full width turn lanes greater than 500 feet in length, collector lanes, shoulders, and any additional equipment necessary to remove pavement in the area of manholes, water valves, curb, gutter and other obstructions.

**Page 6-6, Subarticle 607-5(C) Incidental Milling, lines 45-49,** delete and replace the first and second sentence with the following:

*Incidental Milling* will be measured and paid as the actual number of square yards of surface milled where the Contractor is required to mill butt joints, irregular areas, full width turn lanes 500 feet or less, intersections and re-mill areas that are not due to the Contractor's negligence. In measuring this quantity, the length will be the actual length milled, measured along the pavement surface. The width will be the width required by the plans or directed by the Engineer, measured along the pavement surface.

**Page 6-7, Subarticle 607-5(D) Milling of Defects, lines 6-10,** delete and replace the second sentence with the following:

If the Engineer directs re-milling of an area and is not due to the Contractor's negligence, the re-milled area will be measured as provided in Subarticle 607-5(C) and paid at the contract unit price per square yard for *Incidental Milling*.

**PRICE ADJUSTMENT - ASPHALT BINDER FOR PLANT MIX:**

(11-21-00)

620

SP6 R25

Price adjustments for asphalt binder for plant mix will be made in accordance with Section 620 of the *2018 Standard Specifications*.

The base price index for asphalt binder for plant mix is \$ **623.13** per ton.

This base price index represents an average of F.O.B. selling prices of asphalt binder at supplier's terminals on **July 1, 2023**.

**FINAL SURFACE TESTING NOT REQUIRED:**

(5-18-04) (Rev. 2-16-16)

610

SP6 R45

Final surface testing is not required on this project in accordance with Section 610-13, *Final Surface Testing and Acceptance*.

**ASPHALT CONCRETE PLANT MIX PAVEMENTS:**

(2-20-18) (Rev. 7-18-23)

610, 1012

SP6 R65

Revise the 2018 *Standard Specifications* as follows:

**Page 6-14, Table 609-3, LIMITS OF PRECISION FOR TEST RESULTS**, replace with the following:

<b>TABLE 609-3</b>	
<b>LIMITS OF PRECISION FOR TEST RESULTS</b>	
<b>Mix Property</b>	<b>Limits of Precision</b>
25.0 mm sieve (Base Mix)	± 10.0%
19.0 mm sieve (Base Mix)	± 10.0%
12.5 mm sieve (Intermediate & Type P-57)	± 6.0%
9.5 mm sieve (Surface Mix)	± 5.0%
4.75 mm sieve (Surface Mix)	± 5.0%
2.36 mm sieve (All Mixes, except S4.75A)	± 5.0%
1.18 mm sieve (S4.75A)	± 5.0%
0.075 mm sieve (All Mixes)	± 2.0%
Asphalt Binder Content	± 0.5%
Maximum Specific Gravity ( $G_{mm}$ )	± 0.020
Bulk Specific Gravity ( $G_{mb}$ )	± 0.030
TSR	± 15.0%
QA retest of prepared QC Gyratory Compacted Volumetric Specimens	± 0.015
Retest of QC Core Sample	± 1.2% (% Compaction)
Comparison QA Core Sample	± 2.0% (% Compaction)
QA Verification Core Sample	± 2.0% (% Compaction)
Density Gauge Comparison of QC Test	± 2.0% (% Compaction)
QA Density Gauge Verification Test	± 2.0% (% Compaction)

**Page 6-17, Table 610-1, MIXING TEMPERATURE AT THE ASPHALT PLANT**, replace with the following:

<b>TABLE 610-1</b>	
<b>MIXING TEMPERATURE AT THE ASPHALT PLANT</b>	
<b>Binder Grade</b>	<b>JMF Temperature</b>
PG 58-28; PG 64-22	250 - 290°F
PG 76-22	300 - 325°F

Page 6-17, Subarticle 610-3(C), Job Mix Formula (JMF), lines 38-39, delete the fourth paragraph.

Page 6-18, Subarticle 610-3(C), Job Mix Formula (JMF), line 12, replace “SF9.5A” with “S9.5B”.

Page 6-18, Table 610-3, MIX DESIGN CRITERIA, replace with the following:

Mix Type	Design ESALs millions <sup>A</sup>	Binder PG Grade	Compaction Levels		Max. Rut Depth (mm)	Volumetric Properties <sup>B</sup>			
			G <sub>mm</sub> @			VMA	VTM	VFA	%G <sub>mm</sub>
			N <sub>ini</sub>	N <sub>des</sub>		% Min.	%	Min.-Max.	@ N <sub>ini</sub>
S4.75A	< 1	64 - 22	6	50	11.5	16.0	4.0 - 6.0	65 - 80	≤ 91.5
S9.5B	0 - 3	64 - 22	6	50	9.5	16.0	3.0 - 5.0	70 - 80	≤ 91.5
S9.5C	3 - 30	64 - 22	7	65	6.5	15.5	3.0 - 5.0	65 - 78	≤ 90.5
S9.5D	> 30	76 - 22	8	100	4.5	15.5	3.0 - 5.0	65 - 78	≤ 90.0
I19.0C	ALL	64 - 22	7	65	-	13.5	3.0 - 5.0	65 - 78	≤ 90.5
B25.0C	ALL	64 - 22	7	65	-	12.5	3.0 - 5.0	65 - 78	≤ 90.5
<b>Design Parameter</b>					<b>Design Criteria</b>				
All Mix Types	Dust to Binder Ratio (P <sub>0.075</sub> / P <sub>be</sub> )				0.6 - 1.4 <sup>C</sup>				
	Tensile Strength Ratio (TSR) <sup>D</sup>				85% Min. <sup>E</sup>				

- A. Based on 20 year design traffic.
- B. Volumetric Properties based on specimens compacted to N<sub>des</sub> as modified by the Department.
- C. Dust to Binder Ratio (P<sub>0.075</sub> / P<sub>be</sub>) for Type S4.75A is 1.0 - 2.0.
- D. NCDOT-T-283 (No Freeze-Thaw cycle required).
- E. TSR for Type S4.75A & B25.0C mixes is 80% minimum.

Page 6-19, Table 610-5, BINDER GRADE REQUIREMENTS (BASED ON RBR%), replace with the following:

Mix Type	%RBR ≤ 20%	21% ≤ %RBR ≤ 30%	%RBR > 30%
S4.75A, S9.5B, S9.5C, I19.0C, B25.0C	PG 64-22	PG 64-22 <sup>A</sup>	PG-58-28
S9.5D, OGFC	PG 76-22 <sup>B</sup>	n/a	n/a

- A. If the mix contains any amount of RAS, the virgin binder shall be PG 58-28.
- B. Maximum Recycled Binder Replacement (%RBR) is 18% for mixes using PG 76-22 binder.

Page 6-20, Table 610-6, PLACEMENT TEMPERATURES FOR ASPHALT, replace with the following:

Asphalt Concrete Mix Type	Minimum Surface and Air Temperature
B25.0C	35°F
I19.0C	35°F
S4.75A, S9.5B, S9.5C	40°F <sup>A</sup>
S9.5D	50°F

- A. For the final layer of surface mixes containing recycled asphalt shingles (RAS), the minimum surface and air temperature shall be 50°F.

**Page 6-21, Article 610-8, SPREADING AND FINISHING, lines 34-35,** delete the second sentence and replace with the following:

Use an MTV for all surface mix regardless of binder grade on Interstates, US Routes, and NC Routes (primary routes) that have 4 or more lanes and are median divided.

**Page 6-21, Article 610-8, SPREADING AND FINISHING, lines 36-38,** delete the fourth sentence and replace with the following:

Use MTV for all ramps, loops, and Y-lines that have 4 or more lanes and are median divided, and all full width acceleration lanes, full width deceleration lanes, and full width turn lanes that are greater than 1000 feet in length.

**Page 6-23, Table 610-7, DENSITY REQUIREMENTS,** replace with the following:

<b>TABLE 610-7 DENSITY REQUIREMENTS</b>	
<b>Mix Type</b>	<b>Minimum % G<sub>mm</sub> (Maximum Specific Gravity)</b>
S4.75A	85.0 <sup>A</sup>
S9.5B	90.0
S9.5C, S9.5D, I19.0C, B25.0C	92.0

- A. Compaction to the above specified density shall be required when the S4.75A mix is applied at a rate of 100 lbs/sy or higher.

**Page 6-24, Article 610-13, FINAL SURFACE TESTING, lines 35-36,** delete the second sentence and replace with the following:

Final surface testing is not required on ramps, loops and turn lanes.

**Page 6-26, Subarticle 610-13(A)(1), Acceptance for New Construction, lines 29-30,** delete the second sentence and replace with the following:

Areas excluded from testing by the profiler may be tested using a 10-foot straightedge in accordance with Article 610-12.

**Page 6-27, Subarticle 610-13(B), Option 2- North Carolina Hearne Straightedge, lines 41-46,** delete the eighth and ninth sentence of this paragraph and replace with the following:

Take profiles over the entire length of the final surface travel lane pavement exclusive of structures, approach slabs, paved shoulders, tapers, or other irregular shaped areas of pavement, unless otherwise approved by the Engineer. Test in accordance with this provision all mainline travel lanes, full width acceleration or deceleration lanes and collector lanes.

**Page 6-28, Subarticle 610-13(B), Option 2- North Carolina Hearne Straightedge, lines 1-2,** delete these two lines.

**Page 6-32, Article 610-16 MEASUREMENT AND PAYMENT,** replace with the following:

<b>Pay Item</b>	<b>Pay Unit</b>
Asphalt Concrete Base Course, Type B25.0C	Ton
Asphalt Concrete Intermediate Course, Type I19.0C	Ton
Asphalt Concrete Surface Course, Type S4.75A	Ton
Asphalt Concrete Surface Course, Type S9.5B	Ton
Asphalt Concrete Surface Course, Type S9.5C	Ton
Asphalt Concrete Surface Course, Type S9.5D	Ton

**Page 10-30, Table 1012-1, AGGREGATE CONSENSUS PROPERTIES**, replace with the following:

**TABLE 1012-1  
AGGREGATE CONSENSUS PROPERTIES<sup>A</sup>**

<b>Mix Type</b>	<b>Coarse Aggregate Angularity<sup>B</sup></b>	<b>Fine Aggregate Angularity % Minimum</b>	<b>Sand Equivalent % Minimum</b>	<b>Flat and Elongated 5 : 1 Ratio % Maximum</b>
<i>Test Method</i>	<i>ASTM D5821</i>	<i>AASHTO T 304</i>	<i>AASHTO T 176</i>	<i>ASTM D4791</i>
S4.75A; S9.5B	75 / -	40	40	-
S9.5C; I19.0C; B25.0C	95 / 90	45	45	10
S9.5D	100 / 100	45	50	10
OGFC	100 / 100	45	45	10
UBWC	100 / 85	45	45	10

A. Requirements apply to the design aggregate blend.

B. 95 / 90 denotes that 95% of the coarse aggregate has one fractured face and 90% has 2 or more fractured faces.

**Page 10-30, Subarticle 1012-1(B)(6), Toughness (Resistance to Abrasion), line 12**, replace “OGAFC” with “OGFC”.

**SUPPLEMENTAL SURVEYING:**

(4-20-21)

801

SP8 R03

Revise the *2018 Standard Specifications* as follows:

**Page 8-7, Article 801-3 MEASUREMENT AND PAYMENT**, lines 10-11, replace with the following:

*Supplemental Surveying Office Calculations* will be paid at the stated price of \$85.00 per

hour. *Supplemental Field Surveying* will be paid at the stated price of \$145.00 per hour. The

**PORTLAND CEMENT CONCRETE PRODUCTION AND DELIVERY:**

(9-15-20)

1000, 1014, 1024

SP10 R01

Revise the 2018 *Standard Specifications* as follows:

Page 10-6, Table 1000-1, REQUIREMENTS FOR CONCRETE, replace with the following:

TABLE 1000-1 REQUIREMENTS FOR CONCRETE											
Class of Concrete	Min. Compressive Strength at 28 days	Maximum Water-Cement Ratio				Consistency Maximum Slump		Cement Content			
		Air-Entrained Concrete		Non-Air- Entrained Concrete		Vibrated	Non- Vibrated	Vibrated		Non-Vibrated	
		Rounded Aggregate	Angular Aggregate	Rounded Aggregate	Angular Aggregate			Min.	Max.	Min.	Max.
<i>Units</i>	<i>psi</i>					<i>inch</i>	<i>inch</i>	<i>lb/cy</i>	<i>lb/cy</i>	<i>lb/cy</i>	<i>lb/cy</i>
AA	4500	0.381	0.426	---	---	3.5 <sup>A</sup>	---	639	715	---	---
AA Slip Form	4500	0.381	0.426	---	---	1.5	---	639	715	---	---
Drilled Pier	4500	---	---	0.450	0.450	---	5 - 7 dry  7 - 9 wet	---	---	640	800
A	3000	0.488	0.532	0.550	0.594	3.5 <sup>A</sup>	4.0	564	---	602	---
B	2500	0.488	0.567	0.559	0.630	1.5 machine placed  2.5 <sup>A</sup> hand placed	4.0	508	---	545	---
Sand Light- weight	4500	---	0.420	---	---	4.0 <sup>A</sup>	---	715	---	---	---
Latex Modified	3000 (at 7 days)	0.400	0.400	---	---	6.0	---	658	---	---	---
Flowable Fill excavatable	150 max. (at 56 days)	as needed	as needed	as needed	as needed	---	Flowable	---	---	40	100
Flowable Fill non- excavatable	125	as needed	as needed	as needed	as needed	---	Flowable	---	---	100	as needed
Pavement	4500 Design, field  650	0.559	0.559	---	---	1.5 slip form  3.0 hand placed	---	526	---	---	---



	flexural, design only										
Precast	See Table 1077-1	as needed	as needed	---	---	6.0	as needed	as needed	as needed	as needed	as needed
Prestressed	per contract	See Table 1078-1	See Table 1078-1	---	---	8.0	---	564	as needed	---	---

- A. The slump may be increased to 6 inches, provided the increase in slump is achieved by adding a chemical admixture conforming to Section 1024-3. In no case shall the water-cement ratio on the approved design be exceeded. Concrete exhibiting segregation and/or excessive bleeding will be rejected. Utilizing an Admixture to modify slump does not relinquish the contractor’s responsibility to ensure the final product quality and overall configuration meets design specifications. Caution should be taken when placing these modified mixes on steep grades to prevent unintended changes to the set slope.

**MATERIALS FOR PORTLAND CEMENT CONCRETE:**

(9-15-20)

1000, 1024

SP10 R24

Revise the *2018 Standard Specifications* as follows:

**Page 10-52, Article 1024-4, WATER, lines 3-6,** delete and replace with the following:

Test water from wells at all locations. Test public water supplies from all out of state locations and in the following counties: Beaufort, Bertie, Brunswick, Camden, Carteret, Chowan, Craven, Currituck, Dare, Gates, Hyde, New Hanover, Onslow, Pamlico, Pasquotank, Pender, Perquimans, Tyrell and Washington unless the Engineer waives the testing requirements.

**Page 10-52, Table 1024-2, PHYSICAL PROPERTIES OF WATER,** replace with the following:

<b>Property</b>	<b>Requirement</b>	<b>Test Method</b>
Compression Strength, minimum percent of control at 3 and 7 days	90%	ASTM C1602
Time of set, deviation from control	From 1:00 hr. earlier to 1:30 hr. later	ASTM C1602
pH	4.5 to 8.5	ASTM D1293 *
Chloride Ion Content, Max.	250 ppm	ASTM D512 *
Total Solids Content (Residue), Max.	1,000 ppm	SM 2540B *
Resistivity, Min.	0.500 kohm-cm	ASTM D1125 *

\*Denotes an alternate method is acceptable. Test method used shall be referenced in the test report.

**GEOSYNTHETICS:**

(03-21-23)(Rev. 4-18-23)

1056

SP10 R56

Revise the *Standard Specifications* as follows:

**Page 10-77, Article 1056-1 DESCRIPTION, lines 13-16,** delete and replace the second sentence in the second paragraph with the following:

Steel anchor pins shall have a diameter of at least 3/16 inch, a length of at least 18 inches, a point at one end and a head at the other end that will retain a steel washer with an outside diameter of at least 1.5 inches.

**Page 10-77, Article 1056-2 HANDLING AND STORING, lines 20-21,** delete and replace the third sentence in the first paragraph with the following:

Geosynthetics with defects, flaws, deterioration or damage will be rejected by the Engineer.

**Page 10-77, Article 1056-3 CERTIFICATIONS AND IDENTIFICATION, lines 25-27,** delete and replace the first sentence in the first paragraph with the following:

Provide Type 1, Type 2 or Type 4 material certifications in accordance with Article 106-3 for geosynthetics except certifications are not required for Type 1 through Type 5 geotextiles.

**Page 10-77, Article 1056-3 CERTIFICATIONS AND IDENTIFICATION, lines 32-35,** delete the second paragraph.

**Page 10-77, Article 1056-3 CERTIFICATIONS AND IDENTIFICATION, lines 36-41,** delete and replace the third paragraph with the following:

Allow the Engineer to visually identify geosynthetic products before installation. Open packaged geosynthetics just before use in the presence of the Engineer to verify the correct product. Geosynthetics that are missing original packaging or product labels or that have been unwrapped or previously opened will be rejected unless otherwise approved by the Engineer.

**Page 10-77, Article 1056-4 GEOTEXTILES, lines 43-45,** delete the first paragraph.

**Page 10-78, Article 1056-4 GEOTEXTILES, before line 1 and lines 1-5,** delete Table 1056-1 and lines 1-5 and replace with the following:

TABLE 1056-1 GEOTEXTILE REQUIREMENTS						
Property <sup>A</sup>	Requirement (MARV <sup>A</sup> )					Test Method
	Type 1	Type 2	Type 3 <sup>B</sup>	Type 4	Type 5 <sup>C</sup>	
<i>Typical Application</i>	<i>Shoulder Drains</i>	<i>Under Rip Rap</i>	<i>Silt Fence Fabric</i>	<i>Soil Stabilization</i>	<i>Subgrade Stabilization</i>	
Elongation (MD & CD)	≥ 50%	≥ 50%	≤ 25%	< 50%	< 50%	ASTM D4632
Grab Strength (MD & CD) <sup>A</sup>	Table 1 <sup>D</sup> , Class 3	Table 1 <sup>D</sup> , Class 1	100 lb	Table 1 <sup>D</sup> , Class 3	-	ASTM D4632
Tear Strength (MD & CD) <sup>A</sup>			-			ASTM D4533
Puncture Strength			-			ASTM D6241
Ultimate Tensile Strength (MD & CD) <sup>A</sup>	-	-	-	-	Table 12 <sup>D</sup> , Class 4A	ASTM D4595
Permittivity	Table 2 <sup>D</sup> , 15% to 50% <i>in Situ</i> Soil Passing 0.075 mm	Table 6 <sup>D</sup> , 15% to 50% <i>in Situ</i> Soil Passing 0.075 mm	Table 7 <sup>D</sup>	Table 5 <sup>D</sup>	Table 12 <sup>D</sup> , Class 4A	ASTM D4491
Apparent Opening Size						ASTM D4751
UV Stability (Retained Strength)						ASTM D4355

A. MD, CD and MARV per Article 1056-3.

B. Minimum roll width of 36 inches required.

C. Minimum roll width of 13 feet required unless otherwise approved by the Engineer for the application.

D. Per AASHTO M 288.

Page 10-78, Article 1056-5 GEOCOMPOSITE DRAINS, before line 9 and lines 9-10, delete Table 1056-2 and lines 9-10 and replace with the following:

TABLE 1056-2 GEOCOMPOSITE DRAIN REQUIREMENTS				
Property	Requirement			Test Method
	Sheet Drain	Strip Drain	Wick Drain	
Width	≥ 12"	12" ±1/4"	4" ±1/4"	N/A
In-Plane Flow Rate <sup>A</sup> (with gradient of 1.0 and 24-hour seating period)	6 gpm/ft @ applied normal compressive stress of 10 psi	15 gpm/ft @ applied normal compressive stress of 7.26 psi	1.5 gpm <sup>B</sup> @ applied normal compressive stress of 1.45 psi	ASTM D4716

A. MARV per Article 1056-3.

B. Per foot of width tested.

**Page 10-79, Article 1056-5 GEOCOMPOSITE DRAINS, before line 3, delete Table 1056-3 and replace with the following:**

<b>TABLE 1056-3 DRAINAGE CORE REQUIREMENTS</b>			
<b>Property</b>	<b>Requirement</b>		<b>Test Method</b>
	<b>Sheet Drain</b>	<b>Strip Drain</b>	
Thickness	1/4"	1"	ASTM D1777 or D5199
Compressive Strength <sup>A</sup>	40 psi	30 psi	ASTM D6364

**A.** MARV per Article 1056-3.

**Page 10-79, Article 1056-5 GEOCOMPOSITE DRAINS, before line 6 and lines 6-11, delete Table 1056-4, lines 6-7 and the last paragraph and replace with the following:**

<b>TABLE 1056-4 WICK DRAIN GEOTEXTILE REQUIREMENTS</b>		
<b>Property</b>	<b>Requirement</b>	<b>Test Method</b>
Elongation	≥ 50%	ASTM D4632
Grab Strength	Table 1 <sup>A</sup> , Class 3	ASTM D4632
Tear Strength		ASTM D4533
Puncture Strength		ASTM D6241
Permittivity <sup>B</sup>	0.7 sec <sup>-1</sup>	ASTM D4491
Apparent Opening Size (AOS)	Table 2 <sup>A</sup> , > 50% <i>in Situ</i> Soil Passing 0.075 mm	ASTM D4751
UV Stability (Retained Strength)		ASTM D4355

**A.** Per AASHTO M 288.

**B.** MARV per Article 1056-3.

For wick drains with a geotextile fused to both faces of a corrugated drainage core along the peaks of the corrugations, use wick drains with an ultimate tensile strength of at least 1,650 lbs. per 4 inch width in accordance with ASTM D4595 and geotextiles with a permittivity, AOS and UV stability that meet Table 1056-4.

**Page 10-80, Article 1056-6 GEOCELLS, before line 1 and lines 1-4, delete Table 1056-5 and lines 1-4 and replace with the following:**

<b>TABLE 1056-5 GEOCELL REQUIREMENTS</b>		
<b>Property</b>	<b>Requirement</b>	<b>Test Method</b>
Cell Depth	4"	N/A
Fully Expanded Cell Area	100 sq.in. max	N/A
Sheet Thickness	50 mil -5%, +10%	ASTM D5199
Density	58.4 pcf min	ASTM D1505
Carbon Black Content	1.5% min	ASTM D1603 or D4218
ESCR <sup>A</sup>	5000 hr min	ASTM D1693
Coefficient of Direct Sliding (with material that meets AASHTO M 145 for soil classification A-2)	0.85 min	ASTM D5321
Short-Term Seam (Peel) Strength (for 4" seam)	320 lb min	USACE <sup>C</sup> Technical Report GL-86-19, Appendix A
Long-Term Seam (Hang) Strength <sup>B</sup> (for 4" seam)	160 lb min	

A. Environmental Stress Crack Resistance.

B. Minimum test period of 168 hours with a temperature change from 74°F to 130°F in 1-hour cycles.

C. US Army Corps of Engineers (USACE).

**MATERIAL AND EQUIPMENT STORAGE & PARKING OF PERSONAL VEHICLES:**

11-17-21(Rev. 8-16-22)

1101

SP11 R03

Revise the *2018 Standard Specifications* as follows:

**Page 11-2, Article 1101-8 MATERIAL AND EQUIPMENT STORAGE, line 35-38, delete and replace with the following:**

When work is not in progress, keep all personnel, equipment, machinery, tools, construction debris, materials and supplies away from active travel lanes that meets Table 1101-1.

<b>TABLE 1101-1 MATERIAL AND EQUIPMENT STORAGE FROM ACTIVE TRAVEL LANES</b>	
<b>Posted Speed Limit (mph)</b>	<b>Distance (ft)</b>
40 or less	≥ 18
45-50	≥ 28
55	≥ 32
60 or higher	≥ 40

When vehicles, equipment and materials are protected by concrete barrier or guardrail, they shall be offset at least 5 feet from the barrier or guardrail.

**Page 11-2, Article 1101-9 PARKING OF PERSONAL VEHICLES, line 40-41, delete and replace with the following:**

Provide staging areas for personal vehicle parking in accordance with Article 1101-8 or as directed by the Engineer before use.

**WORK ZONE INSTALLER:**

(7-20-21)(Rev. 8-16-22)

1101, 1150

SP11 R04

Provide the service of at least one qualified work zone installer during the setup, installation, and removal of temporary traffic control within the highway right of way. The qualified work zone installer shall serve as crew leader and shall be on site and directing the installation and removal of temporary traffic control. If multiple temporary traffic control installations or removals are occurring simultaneously, then each shall have a qualified work zone installer.

The work zone installer shall be qualified by an NCDOT approved training agency or other NCDOT approved training provider in the safe and competent set up of temporary traffic control. For a complete listing of approved training agencies, see the Work Zone Safety Training webpage.

A work zone supervisor, in accordance with Article 1101-13 of the *Standard Specifications*, may fulfill the role of the work zone installer during the setup, installation, and removal of temporary traffic control within the highway right of way provided they are on site and directing the installation and removal of temporary traffic control.

All other individuals participating in the setup, installation, and removal of temporary traffic control within the highway right of way shall be certified as a qualified flagger in accordance with Article 1150-3 of the *Standard Specifications*, even if flagging is not being performed as part of the traffic control.

Provide the name and contact information of all qualified work zone installers to the Engineer prior to or at the preconstruction conference. Additionally, provide a qualification statement that all other individuals participating in the setup, installation, and removal of temporary traffic control are qualified flaggers that have been properly trained through an NCDOT approved training agency or other NCDOT approved training provider.

All certification records for qualified work zone installers and flaggers shall be uploaded by the approved training agency or other NCDOT approved training provider to the Department's Work Zone Education Verification App (WZ-EVA) prior to the qualified work zone installer or flagger performing any traffic control duties on the project. For more information about WZ-EVA, see the Work Zone Safety Training webpage.

**PORTABLE CHANGEABLE MESSAGE SIGNS:**

(9-20-22)(Rev. 11-15-22)

1089, 1120

SP11 R10

Revise the *2018 Standard Specifications* as follows:

**Page 10-197, Subarticle 1089-7(D) Controller, line 16**, add the following after the third sentence of the first paragraph:

Change the controller password from the factory default and periodically change the controller password to deter unauthorized programming of the controller.

**Page 10-197, Subarticle 1089-7(D) Controller, lines 16-19**, replace the fourth sentence of the first paragraph with the following:

The password system is recommended to include at least two levels of security such that operators at one level may only change message sequences displayed using preprogrammed sequences and operators at a higher level may create and store messages or message sequences.

**Page 10-197, Subarticle 1089-7(D) Controller, line 24** replace the sentence with the following:

The controller shall be stored in a locked, weather and vandal resistant box when not in use and after changes to the messages are made.

**Page 11-8, Article 1120-3 CONSTRUCTION METHODS, lines 26-32**, replace the second paragraph with the following:

Provide an experienced operator for the portable changeable message sign during periods of operation to ensure that the messages displayed on the sign panel are in accordance with the plans and Subarticle 1089-7(D). Change the controller password from the factory default and periodically change the controller password to deter unauthorized programming of the controller. Using two levels of password security is recommended such that operators at one level may only change message sequences displayed using preprogrammed sequences and operators at a higher level may create and store messages or message sequences. Lock the controller in a weather and vandal resistant box when not in use and after changes to the messages are made.

**PORTABLE CONSTRUCTION LIGHTING:**

4-19-22

1413

SP14 R13

Revise the *2018 Standard Specifications* as follows:

**Page 14-24, Article 1413-3 TOWER LIGHT, lines 2-7**, delete and replace the first and second sentence in the first paragraph with the following:

Use tower lights which consist of mercury vapor, metal halide, high pressure sodium, low pressure sodium or light emitting diode (with correlated color temperature of 4000 Kelvin or less) fixtures mounted on a tower approximately 30 feet in height. Use tower light fixtures which are heavy duty flood, area, or roadway style with wide beam spread, have sufficient output to provide the minimum illumination requirements for the Category of work, are weatherproof and supplied with attached waterproof power cord and plug.

**Page 14-24, Article 1413-3 TOWER LIGHT, lines 11-12,** delete and replace the second paragraph with the following:

Provide tower lights of sufficient wattage or quantity to provide the minimum average maintained horizontal illuminance over the work area based on the Category of work as shown in Table 1413-1. For any work not covered in Table 1413-1, provide a minimum average maintained horizontal illuminance of 20.0 footcandles over the work area.

Category	Description of Construction and Maintenance Task	Minimum Average Maintained Horizontal Illuminance
I	Excavation; Embankment, Fill and Compaction; Maintenance of Embankment; Asphalt Pavement Rolling; Subgrade, Stabilization and Construction; Base Course Rolling; Sweeping and Cleaning; Landscaping, Sod and Seeding; Reworking Shoulders.	5.0 footcandle
II	Barrier Wall and Traffic Separators; Milling, Removal of Pavement; Asphalt Paving and Resurfacing; Concrete Pavement; Base Course Grading and Shaping; Surface Treatment; Waterproofing and Sealing; Sidewalk Construction; Guardrails and Fencing; Striping and Pavement Marking; Highway Signs; Bridge Decks; Drainage Structures and Drainage Piping; Other Concrete Structures; Repair of Concrete Pavement; Pothole Filling; Repair of Guardrail and Fencing.	10.0 footcandle
III	Traffic Signals; Highway Lighting Systems; Crack Filling.	20.0 footcandle

**Page 14-24, Article 1413-4 MACHINE LIGHTS, lines 18-21,** delete and replace the first and second sentence in the first paragraph with the following:

Use machine lights which have mercury vapor, metal halide, high pressure sodium, low pressure sodium or light emitting diode (with correlated color temperature of 4000 Kelvin or less) fixtures mounted on supports attached to the construction machine at a height of approximately 13 feet.

**Page 14-24, Article 1413-5 CONSTRUCTION METHODS, lines 33-34,** delete and replace the third and fourth sentence in the first paragraph with the following:

Submit photometric calculations showing the minimum average maintained horizontal illuminance over the work area and the tower spacing to the Engineer for review and approval prior to installation.



**STANDARD SPECIAL PROVISION**  
**AVAILABILITY OF FUNDS – TERMINATION OF CONTRACTS**

(5-20-08)

Z-2

*General Statute 143C-6-11. (h) Highway Appropriation* is hereby incorporated verbatim in this contract as follows:

(h) Amounts Encumbered. – Transportation project appropriations may be encumbered in the amount of allotments made to the Department of Transportation by the Director for the estimated payments for transportation project contract work to be performed in the appropriation fiscal year. The allotments shall be multiyear allotments and shall be based on estimated revenues and shall be subject to the maximum contract authority contained in *General Statute 143C-6-11(c)*. Payment for transportation project work performed pursuant to contract in any fiscal year other than the current fiscal year is subject to appropriations by the General Assembly. Transportation project contracts shall contain a schedule of estimated completion progress, and any acceleration of this progress shall be subject to the approval of the Department of Transportation provided funds are available. The State reserves the right to terminate or suspend any transportation project contract, and any transportation project contract shall be so terminated or suspended if funds will not be available for payment of the work to be performed during that fiscal year pursuant to the contract. In the event of termination of any contract, the contractor shall be given a written notice of termination at least 60 days before completion of scheduled work for which funds are available. In the event of termination, the contractor shall be paid for the work already performed in accordance with the contract specifications.

Payment will be made on any contract terminated pursuant to the special provision in accordance with Subarticle 108-13(D) of the *2018 Standard Specifications*.

**STANDARD SPECIAL PROVISION**  
**NCDOT GENERAL SEED SPECIFICATION FOR SEED QUALITY**

(5-17-11)

Z-3

Seed shall be sampled and tested by the North Carolina Department of Agriculture and Consumer Services, Seed Testing Laboratory. When said samples are collected, the vendor shall supply an independent laboratory report for each lot to be tested. Results from seed so sampled shall be final. Seed not meeting the specifications shall be rejected by the Department of Transportation and shall not be delivered to North Carolina Department of Transportation warehouses. If seed has been delivered it shall be available for pickup and replacement at the supplier's expense.

Any re-labeling required by the North Carolina Department of Agriculture and Consumer Services, Seed Testing Laboratory, that would cause the label to reflect as otherwise specified herein shall be rejected by the North Carolina Department of Transportation.

Seed shall be free from seeds of the noxious weeds Johnsongrass, Balloonvine, Jimsonweed, Witchweed, Itchgrass, Serrated Tussock, Showy Crotalaria, Smooth Crotalaria, Sicklepod, Sandbur, Wild Onion, and Wild Garlic. Seed shall not be labeled with the above weed species on the seed analysis label. Tolerances as applied by the Association of Official Seed Analysts will NOT be allowed for the above noxious weeds except for Wild Onion and Wild Garlic.

Tolerances established by the Association of Official Seed Analysts will generally be recognized. However, for the purpose of figuring pure live seed, the found pure seed and found germination percentages as reported by the North Carolina Department of Agriculture and Consumer Services, Seed Testing Laboratory will be used. Allowances, as established by the NCDOT, will be recognized for minimum pure live seed as listed on the following pages.

The specifications for restricted noxious weed seed refers to the number per pound as follows:

<b><u>Restricted Noxious Weed</u></b>	<b><u>Limitations per Lb. Of Seed</u></b>	<b><u>Restricted Noxious Weed</u></b>	<b><u>Limitations per Lb. of Seed</u></b>
Blessed Thistle	4 seeds	Cornflower (Ragged Robin)	27 seeds
Cocklebur	4 seeds	Texas Panicum	27 seeds
Spurred Anoda	4 seeds	Bracted Plantain	54 seeds
Velvetleaf	4 seeds	Buckhorn Plantain	54 seeds
Morning-glory	8 seeds	Broadleaf Dock	54 seeds
Corn Cockle	10 seeds	Curly Dock	54 seeds
Wild Radish	12 seeds	Dodder	54 seeds
Purple Nutsedge	27 seeds	Giant Foxtail	54 seeds
Yellow Nutsedge	27 seeds	Horsenettle	54 seeds
Canada Thistle	27 seeds	Quackgrass	54 seeds
Field Bindweed	27 seeds	Wild Mustard	54 seeds
Hedge Bindweed	27 seeds		

Seed of Pensacola Bahiagrass shall not contain more than 7% inert matter, Kentucky Bluegrass, Centipede and Fine or Hard Fescue shall not contain more than 5% inert matter whereas a maximum of 2% inert matter will be allowed on all other kinds of seed. In addition, all seed shall

not contain more than 2% other crop seed nor more than 1% total weed seed. The germination rate as tested by the North Carolina Department of Agriculture shall not fall below 70%, which includes both dormant and hard seed. Seed shall be labeled with not more than 7%, 5% or 2% inert matter (according to above specifications), 2% other crop seed and 1% total weed seed.

Exceptions may be made for minimum pure live seed allowances when cases of seed variety shortages are verified. Pure live seed percentages will be applied in a verified shortage situation. Those purchase orders of deficient seed lots will be credited with the percentage that the seed is deficient.

FURTHER SPECIFICATIONS FOR EACH SEED GROUP ARE GIVEN BELOW:

Minimum 85% pure live seed; maximum 1% total weed seed; maximum 2% total other crop seed; maximum 144 restricted noxious weed seed per pound. Seed less than 83% pure live seed will not be approved.

Sericea Lespedeza  
Oats (seeds)

Minimum 80% pure live seed; maximum 1% total weed seed; maximum 2% total other crop; maximum 144 restricted noxious weed seed per pound. Seed less than 78% pure live seed will not be approved.

Tall Fescue (all approved varieties)	Bermudagrass
Kobe Lespedeza	Browntop Millet
Korean Lespedeza	German Millet – Strain R
Weeping Lovegrass	Clover – Red/White/Crimson
Carpetgrass	

Minimum 78% pure live seed; maximum 1% total weed seed; maximum 2% total other crop seed; maximum 144 restricted noxious weed seed per pound. Seed less than 76% pure live seed will not be approved.

Common or Sweet Sundangrass

Minimum 76% pure live seed; maximum 1% total weed seed; maximum 2% total other crop seed; maximum 144 restricted noxious weed seed per pound. Seed less than 74% pure live seed will not be approved.

Rye (grain; all varieties)  
Kentucky Bluegrass (all approved varieties)  
Hard Fescue (all approved varieties)  
Shrub (bicolor) Lespedeza

Minimum 70% pure live seed; maximum 1% total weed seed; maximum 2% total other crop seed; maximum 144 noxious weed seed per pound. Seed less than 70% pure live seed will not be approved.

Centipedegrass	Japanese Millet
Crownvetch	Reed Canary Grass
Pensacola Bahiagrass	Zoysia
Creeping Red Fescue	

Minimum 70% pure live seed; maximum 1% total weed seed; maximum 2% total other crop seed; maximum 5% inert matter; maximum 144 restricted noxious weed seed per pound.

- Barnyard Grass
- Big Bluestem
- Little Bluestem
- Bristly Locust
- Birdsfoot Trefoil
- Indiangrass
- Orchardgrass
- Switchgrass
- Yellow Blossom Sweet Clover

**STANDARD SPECIAL PROVISION****ERRATA**

(10-16-18) (Rev. 6-20-23)

Z-4

Revise the *2018 Standard Specifications* as follows:

**Division 1**

**Page 1-1, Article 101-2 Abbreviations, line 13**, replace " American National Standards Institute, Inc." with "American National Standards Institute".

**Page 1-1, Article 101-2 Abbreviations, line 32**, replace "Equivalent Single Axis Load" with "Equivalent Single Axle Load".

**Page 1-16, Subarticle 102-9(A) General, line 26**, replace "10 U.S.C. 2304(g)" with "10 U.S.C. 3205".

**Page 1-43, Article 104-13 RECYCLED PRODUCTS OR SOLID WASTE MATERIALS, line 4**, replace "104-13(B)(2)" with "104-13(B)".

**Page 1-52, Article 106-1 RECYCLED PRODUCTS OR SOLID WASTE MATERIALS, line 25**, replace "13 NCAC 7CF.0101(a)(99)" with "29 CFR 1910.1200".

**Page 1-79, Article 109-1 MEASUREMENT AND PAYMENT, Test Method prior to line 34**, replace "AASHTO M 32" with "AASHTO M 336".

**Division 2**

**Page 2-5, Article 210-2 CONSTRUCTION METHODS, line 21**, replace " NCGS §§ 130A-444 to -452" with "NCGS §§ 130A-444 to -453".

**Page 2-13, Article 225-2 EROSION CONTROL REQUIREMENTS, line 17**, replace "the Sedimentation and Pollution Control Act" with "Article 107-12".

**Page 2-20, Subarticle 230-4(B)(3) Reclamation Plan, line 12**, replace " Department's borrow and waste site reclamation procedures for contracted projects" with "Department's *Borrow Waste and Staging Site Reclamation Procedures for Contract Projects*".

**Page 2-25, Subarticle 235-3(E) Surcharges and Waiting Periods, line 21 and 27**, delete "Department's Materials and Tests Unit."

**Page 2-27, Article 240-4 MEASUREMENT AND PAYMENT, line 23**, replace "Section 225" with "Article 225-7".

**Page 2-30, Article 275-4 MEASUREMENT AND PAYMENT, line 33**, replace "Section 815" with "Article 815-4".

**Division 4**

**Page 4-18, Subarticle 411-5(C)(3) Coring, line 11**, replace "in accordance with ASTM D5079" with "with methods acceptable to the Engineer".

**Page 4-50, Article 430-2 MATERIALS, prior to line 15,** replace Section “1080-9” with “1080-7”.

**Page 4-53, Article 440-2 MATERIALS, prior to line 6,** replace Section “1080-9” with “1080-7”.

**Page 4-58, Article 442-2 MATERIALS, prior to line 15,** replace Section “1080-6” with “1080-12”.

**Page 4-59, Subarticle 442-7(A) Blast Cleaning, line 36,** replace Article “1080-6” with “1080-12”.

**Page 4-76, Article 454-2 MATERIALS, prior to line 24,** replace Section “815-2” with “1044”.

**Page 4-79, Article 455-2 MATERIALS, prior to line 21,** replace Section “815” with “1044”.

**Page 4-80, Subarticle 455-3(B) Precast Gravity Wall Designs, line 23 and lines 25-26,** replace “AASHTO LRFD specifications” with “*AASHTO LRFD Bridge Design Specifications*”.

**Page 4-84, Article 458-5 MEASUREMENT AND PAYMENT, line 31,** replace article number “454-1” with “458-1”.

#### **Division 6**

**Page 6-7, Article 609-1 DESCRIPTION, line 29,** replace article number “609-10” with “609-9”.

**Page 6-10, Subarticle 609-6(C) Control Charts, line 17,** replace Section number “7021” with “7.20.1”.

**Page 6-13, Article 609-9 QUALITY ASSURANCE, line 31,** replace Section number “7.60” with “7.6”.

**Page 6-26, Subarticle 610-13(A)(1) Acceptance for New Construction, line 31,** replace Table number “610-7” with “610-8”.

**Page 6-29, Subarticle 610-13(B) North Carolina Hearne Straightedge, line 32,** replace Table number “610-8” with “610-9”.

**Page 6-31, Article 610-14 DENSITY ACCEPTANCE, Specified Density prior to line 30 and line 32,** replace Table number “610-6” with “610-7”.

**Page 6-37, Article 650-5 CONSTRUCTION METHODS, line 10,** replace Section number “9.5(E)” with “9.5.1(E)”.

**Page 6-44, Subarticle 660-8(B) Asphalt Mat and Seal, line 40,** replace Subarticle number “660-8(A)” with “660-8(C)”.

**Page 6-44, Subarticle 660-8(B) Asphalt Mat and Seal, line 42,** replace Subarticle number “660-8(C)” with “660-8(A)”.

#### **Division 7**

**Page 7-11, Subarticle 700-15(E) Compressive Strength, line 5,** replace “AASHTO T 23” with “AASHTO R 100”.

**Page 7-24, Article 723-4 Very High Early Strength Concrete for Concrete Pavement Repair, line 4,** replace “AASHTO T126” with “AASHTO R 39”.

**Page 7-24, Article 723-5 MEASUREMENT AND PAYMENT, line 34,** replace "Section 225" with “Article 225-7”.

**Page 7-24, Article 723-5 MEASUREMENT AND PAYMENT, line 36,** replace "Section 270" with “Article 270-4”.

**Page 7-27, Article 725-1 MEASUREMENT AND PAYMENT, line 4,** replace article number “725-1” with “724-4”.

**Page 7-28, Article 725-1 MEASUREMENT AND PAYMENT, line 10,** replace article number “725-1” with “725-3”.

#### **Division 8**

**Page 8-11, Article 815-1 MATERIALS, after line 35,** replace “1080-12” with “1080-10”.

**Page 8-13, Article 816-1 MATERIALS, after line 28,** replace “1080-12” with “1080-10”.

**Page 8-17, Article 825-1 Description, line 5,** delete “853” and “855”.

#### **Division 10**

**Page 10-2, Subarticle 1000-3(B) Air Entrainment, line 33,** replace “Chase” with “Chace”.

**Page 10-4, Subarticle 1000-4(A) Composition and Design, after line 17,** replace “T23” with “R100”.

**Page 10-4, Subarticle 1000-4(B) Air Entrainment, line 31 and 33,** replace “Chase” with “Chace”.

**Page 10-4, Subarticle 1000-4(C) Strength of Concrete, line 39 and 41,** replace “T 23” with “R 100”.

**Page 10-15, Subarticle 1000-11(B) Mixing Time for Central Mixed Concrete, after line 35,** replace “T 23” with “R 100”.

**Page 10-22, Article 1003-3 COMPOSITION AND DESIGN, line 9,** replace “Engineer” with “engineer”.

**Page 10-23, Article 1003-4 GROUT REQUIREMENTS, line 16 and 18,** replace “T 23” with “R 100”.

**Page 10-26, Article 1005-4 TESTING, after line 26,** replace “1014-2€(6)” with “1014-2€(6)” in C. of Table 1005-1 footnote and replace “Lightweight<sup>B</sup>” with “Lightweight<sup>C</sup>”.

**Page 10-29, Subarticle 1012-1(B)(4) Flat and Elongated Pieces, line 44,** delete “SF9.5A”

**Page 10-36, Subarticle 1012-2(E) Toughness (Resistance to Abrasion), line 31,** replace “course” with “coarse”.

**Page 10-37, Article 1012-4, LIGHTWEIGHT AGGREGATE, line 4,** replace Table number “1012-8” with “1012-5”.

**Page 10-48, Subarticle 1020-10(A) Mineral Fibers, line 27,** replace “Table 1012-5” with “Table 1020-2”.

**Page 10-52, Article 1024-5 FLY ASH, line 12,** replace “Table 2” with “Table 3”.

**Page 10-60, Subarticle 1032-6(F) Joint Materials, line 15,** replace “AASHTO M 198” with “ASTM C990” and delete “Type B”.

**Page 10-61, Article 1034-3 CONCRETE SEWER PIPE, line 33,** replace “AASHTO M 198” with “ASTM C990” and delete “Type A or B”.

**Page 10-64, Article 1040-1 BRICK, line 12,** replace “ASTM C62” with “ASTM C62 or ASTM C216”.

**Page 10-67, Article 1044-7 CORRUGATED PLASTIC PIPE AND FITTINGS, line 24,** replace “AASHTO M 294 for heavy duty tubing” with “Article 1032-7 and AASHTO M 252”.

**Page 10-68, Subarticle 1046-3(D) Offset Blocks, lines 30-32,** delete “Before beginning the installation of recycled offset block, submit the FHWA acceptance letter for each type of block to the Engineer for approval.”

**Page 10-69, Subarticle 1046-3(D) Offset Blocks, before line 1,** replace “WIRE DIAMETER” with “COMPOSITE OFFSET BLOCKS” as the title of Table 1046-1, delete “Testing” property and associated requirement from Table 1046-1, and replace “Approval” requirement of “Approved for use by the FHWA” with “Approved for use on the NCDOT APL” in Table 1046-1.

**Page 10-80, Article 1060-2 FERTILIZER, line 18,** replace “North Carolina Fertilizer Law” with “North Carolina Commercial Fertilizer Law”.

**Page 10-83, Article 1060-9 WATER, line 9,** replace “15 NCAC 2B.0200” with “15A NCAC 02B.0200”.

**Page 10-86, Article 1070-3 COLD DRAWN STEEL WIRE AND WIRE REINFORCEMENT, line 23 and 25,** replace “M 32” and “M 55” with “M 336”.



**Page 10-87, Article 1070-6 DOWELS AND TIE BARS FOR PORTLAND CEMENT CONCRETE PAVEMENT, line 17,** replace “AASHTO M 32” with “AASHTO M 336”.

**Page 10-88, Subarticle 1070-7(D) Handling, Storage and Transportation, line 40,** replace “Section” with “Subarticle”.

**Page 10-89, Article 1070-8 SPIRAL COLUMN REINFORCING STEEL, line 21,** replace “AASHTO M 32” with “AASHTO M 336”.

**Page 10-91, Article 1072-3 BEARING PLATE ASSEMBLIES, line 44,** replace “Article 1080-9” with “Article 1080-7”.

**Page 10-92, Subarticle 1072-5(A) General, after line 30,** replace “SAMPLING REQUIREMENTS FOR HIGH STRENGTH BOLTS, NUTS AND WASHERS” with “SAMPLING REQUIREMENTS FOR HIGH STRENGTH BOLTS, NUTS AND WASHERS TO INCLUDE DIRECT TENSION INDICATORS” as the title of Table 1072-1.

**Page 10-95, Subarticle 1072-5(D)(7)(a) Mill Test Report(s), line 18,** replace title with “Mill Test Report(s) (MTR)”.

**Page 10-95, Subarticle 1072-5(D)(7)(b) Manufacturer Certified Test Report(s), line 24,** replace title with “Manufacturer Certified Test Report(s) (MCTR)”.

**Page 10-96, Subarticle 1072-5(D)(7)(c) Distributor Certified Test Report(s), line 1,** replace title with “Distributor Certified Test Report(s) (DCTR)”.

**Page 10-98, Subarticle 1072-5(F) Galvanized High Strength Bolts, Nuts and Washers, line 11,** replace “Article 1080-9” with “Article 1080-7”.

**Page 10-111, Subarticle 1072-18(B) General, line 24,** replace “Structural Welding Code-Reinforcing Steel” with “Structural Welding Code-Steel Reinforcing Bars”.

**Page 10-117, Article 1074-1 WELDING, lines 21-22,** replace “Structural Welding Code-Reinforcing Steel” with “Structural Welding Code-Steel Reinforcing Bars”.

**Page 10-119, Article 1074-7(B) Gray Iron Castings, line 16,** replace “M306” with “AASHTO M 306”.

**Page 10-121, Article 1076-7, REPAIR OF GALVANIZING, line 8,** replace article number “1080-9” with “1080-7”.

**Page 10-125, Subarticle 1077-5(B) Testing, line 31,** replace “T 23” with “R 100”.

**Page 10-131, Subarticle 1078-4(A) Composition and Design, after line 23, in Table 1078-2** replace “T 23” with “R 100”.

**Page 10-135, Subarticle 1078-4(J)(2) Mixing Time for Central Mixed Concrete, line 46,** replace “Table 1078-2” with “Table 1078-3”

**Page 10-136, Subarticle 1078-4(J)(2) Mixing Time for Central Mixed Concrete, after line 17, replace “T23” with “R100”.**

**Page 10-153, Subarticle 1079-1 PREFORMED BEARING PADS, line 8, replace “MIL-C882-D” with “MIL-C-882-E”.**

**Page 10-154, Subarticle 1079-2(A) General, line 6, delete “and 1079-2(E)”.**

**Page 10-156, Article 1080-5 SELF-CURING INORGANIC ZINC PAINT, line 8, replace “AASHTO M 252” with “AASHTO M 300”.**

**Page 10-156, Article 1080-5 SELF-CURING INORGANIC ZINC PAINT, line 20, replace “AASHTO M 253” with “AASHTO M 300”.**

**Page 10-156, Subarticle 1080-9(A) Composition, line 40, replace “Tables 1080-7 through 1080-14” with “Tables 1080-1 through 1080-3”.**

**Page 10-157, Subarticle 1080-9(B) Properties, line 5, replace “Tables 1080-7 through 1080-14” with “Tables 1080-1 through 1080-3”.**

**Page 10-157, Subarticle 1080-9(B) Properties, line 35, replace “Materials and Tests Standards CLS-P-1.0” with “*Structural Steel Shop Coatings Program*”.**

**Page 10-159, Subarticle 1080-9(E) Color Variation, Table 1080-1, replace “ASTM D1159” with “ASTM D1199”.**

**Page 10-159, Subarticle 1080-9(E) Color Variation, Table 1080-1, replace “NCDOT M&T P-10” with “ASTM D6280”.**

**Page 10-161, Subarticle 1080-9(E) Color Variation, Table 1080-3, replace “ASTM D13278” and “ASTM D3278”.**

**Page 10-161, Subarticle 1080-9(E) Color Variation, Table 1080-3, replace “NCDOT M&T P-10” and “Structural Steel Shop Coatings Program”.**

**Page 10-161, Subarticle 1080-9(E) Color Variation, Table 1080-3, add Test Method “ASTM D4400” for the Leneta Sag Test property in Table 1080-3.**

**Page 10-161, Subarticle 1080-9(E) Color Variation, Table 1080-3, add Test Method “ASTM D523” for the Gloss, Specular property in Table 1080-3.**

**Page 10-161, Subarticle 1080-9(E) Color Variation, Table 1080-3, replace Test Method “ASTM” with “ASTM E70” for the pH property in Table 1080-3.**

**Page 10-162, Article 1080-50 PAINT FOR VERTICAL MARKERS, line 1, replace article number “1080-50” with “1080-10”.**

**Page 10-162, Article 1080-61 EPOXY RESIN FOR REINFORCING STEEL, line 5,** replace article number “1080-61” with “1080-11”.

**Page 10-162, Article 1080-72 ABRASIVE MATERIALS FOR BLAST CLEANING STEEL, line 22,** replace article number “1080-72” with “1080-12”.

**Page 10-163, Article 1080-83 FIELD PERFORMANCE AND SERVICES, line 25,** replace article number “1080-83” with “1080-13”.

**Page 10-166, Subarticle 1081-1(E) Prequalification, line 24,** replace “Value Management Unit” with “Product Evaluation Program”.

**Page 10-168, Subarticle 1081-3(A) Physical Requirements, after line 25,** replace “Subarticle 1081-4(B)” with “Subarticle 1081-3(B)” in Table 1081-2.

**Page 10-168, Subarticle 1087-2(A) Paint Composition, lines 19-20,** replace “Federal Specification TTP 1952F” with “Federal Specification TT-P-1952”.

**Page 10-200, Subarticle 1090-1(C) Anchor Bolts, line 38,** replace ASTM number “A325” with “F3125”.

**Page 10-202, Subarticle 1091-3(F) Solid Wall HDPE Conduit, line 5,** replace “, Table 1091-1, 1091-2 and 1091-3” with “and Table 1091-1”.

**Page 10-208, Subarticle 1094-1(A) Breakaway or Simple Steel Beam Sign Supports, line 19,** replace ASTM number “A325” with “F3125”.

**Page 10-209, Subarticle 1094-1(D) Steel Square Tube Posts, line 10,** replace ASTM number “A123” with “A653”.

**Page 10-209, Subarticle 1094-1(E) Wood Supports, line 17,** replace “Article 1082-2 and 1082-3” with “Section 1082”.

**Page 10-212, Subarticle 1098-1(H) Electrical Service, line 21,** replace “NEMA Type 3R” with “NEMA 3R”.

**Page 10-212, Subarticle 1098-1(H) Electrical Service, line 36,** replace “UL Standard 231” with “UL Standard UL-231”.

**Page 10-212, Subarticle 1098-1(H) Electrical Service, line 37,** replace “UL Standard 67” with “UL Standard UL-67”.

**Page 10-224, Subarticle 1098-14(H)(1) Type I – Pedestrian Pushbutton Post, line 3,** replace ASTM number “325” with “F3125”.

**Page 10-224, Article 1098-16 CABINET BASE ADAPTER/EXTENDER, line 33,** replace Section number “6.7” with “6.8”.

**Division 14**

**Page 14-11, Subarticle 1401-2(B) Lowering Device, line 36,** replace Military Specification “MIL-W-83420E” with “MIL-DTL-83420”.

**Page 14-22, Article 1412-2 MATERIALS, line 29,** replace UL Standard “1572” with “1598”.

**Division 15**

**Page 15-6, Subarticle 1510-3(B) Testing and Sterilization, line 40,** replace Section number “4.4.3” with “4.4”.

**Page 15-14, Article 1525-2 MATERIALS, line 9,** replace “AASHTO M 198” with “ASTM C990”.

**Page 15-14, Article 1525-2 MATERIALS, lines 17-18,** delete “in the Grout Production and Delivery provision”.

**Page 15-19, Article 1550-2 MATERIALS, line 16,** replace “*AASHTO LRFD Bridge Design Specifications*” with “*AASHTO LRFD Bridge Construction Specifications*”.

**Division 16**

**Page 16-9, Article 1630-3 MEASUREMENT AND PAYMENT, line 7,** replace "Section 225" with “Article 225-7”.

**Page 16-9, Article 1630-3 MEASUREMENT AND PAYMENT, line 8,** replace "Section 230" with “Article 230-5”.

**Page 16-16, Article 1637-5 MEASUREMENT AND PAYMENT, line 17,** replace "Section 310" with “Article 310-6”.

**Division 17**

**Page 17-15, Article 1715-4 MEASUREMENT AND PAYMENT, lines 42-44,** replace the second sentence with the following:

An example is an installation of a single 1.25 inch HDPE conduit would be paid as:

Directional Drill (1)(1.25") Linear Foot

**Page 17-15, Subarticle 1715-3(E) Bore and Jack, line 5,** replace article number “1540-4” with “1550-4”.

**Page 17-15, Subarticle 1715-3(E) Bore and Jack, lines 10 & 11,** replace "*NCDOT Policies and Procedures for Accommodating Utilities on Highway Rights of Way*" with “*NCDOT Utilities Accommodations Manual*”.

**STANDARD SPECIAL PROVISION****PLANT AND PEST QUARANTINES****(Imported Fire Ant, Gypsy Moth, Witchweed, Emerald Ash Borer, Guava Root Knot Nematode, And Other Noxious Weeds)**

(3-18-03) (Rev. 5-21-19)

Z-04a

**Within Quarantined Area**

This project may be within a county regulated for plant and/or pests. If the project or any part of the Contractor's operations is located within a quarantined area, thoroughly clean all equipment prior to moving out of the quarantined area. Comply with federal/state regulations by obtaining a certificate or limited permit for any regulated article moving from the quarantined area.

**Originating in a Quarantined County**

Obtain a certificate or limited permit issued by the N.C. Department of Agriculture/United States Department of Agriculture. Have the certificate or limited permit accompany the article when it arrives at the project site.

**Contact**

Contact the N.C. Department of Agriculture/United States Department of Agriculture at 1-800-206-9333, 919-707-3730, or <https://www.ncagr.gov/plantindustry/Plant/quaran/table2.htm> to determine those specific project sites located in the quarantined area or for any regulated article used on this project originating in a quarantined county.

**Regulated Articles Include**

1. Soil, sand, gravel, compost, peat, humus, muck, and decomposed manure, separately or with other articles. This includes movement of articles listed above that may be associated with cut/waste, ditch pulling, and shoulder cutting.
2. Plants with roots including grass sod.
3. Plant crowns and roots.
4. Bulbs, corms, rhizomes, and tubers of ornamental plants.
5. Hay, straw, fodder, and plant litter of any kind.
6. Clearing and grubbing debris.
7. Used agricultural cultivating and harvesting equipment.
8. Used earth-moving equipment.
9. Any other products, articles, or means of conveyance, of any character, if determined by an inspector to present a hazard of spreading imported fire ant, gypsy moth, witchweed, emerald ash borer, guava root knot nematode, or other noxious weeds.

**STANDARD SPECIAL PROVISION**

**MINIMUM WAGES**

(7-21-09)

Z-5

**FEDERAL:** The Fair Labor Standards Act provides that with certain exceptions every employer shall pay wages at the rate of not less than SEVEN DOLLARS AND TWENTY FIVE CENTS (\$7.25) per hour.

**STATE:** The North Carolina Minimum Wage Act provides that every employer shall pay to each of his employees, wages at a rate of not less than SEVEN DOLLARS AND TWENTY FIVE CENTS (\$7.25) per hour.

The minimum wage paid to all skilled labor employed on this contract shall be SEVEN DOLLARS AND TWENTY FIVE CENTS (\$7.25) per hour.

The minimum wage paid to all intermediate labor employed on this contract shall be SEVEN DOLLARS AND TWENTY FIVE CENTS (\$7.25) per hour.

The minimum wage paid to all unskilled labor on this contract shall be SEVEN DOLLARS AND TWENTY FIVE CENTS (\$7.25) per hour.

This determination of the intent of the application of this act to the contract on this project is the responsibility of the Contractor.

The Contractor shall have no claim against the Department of Transportation for any changes in the minimum wage laws, Federal or State. It is the responsibility of the Contractor to keep fully informed of all Federal and State Laws affecting his contract.

**STANDARD SPECIAL PROVISION****TITLE VI AND NONDISCRIMINATION:**

(6-28-77)(Rev 6/19/2018)

Z-6

Revise the *2018 Standard Specifications* as follows:

Replace Article 103-4(B) with the following:

The North Carolina Department of Transportation is committed to carrying out the U.S. Department of Transportation's policy of ensuring nondiscrimination in the award and administration of contracts.

The provisions of this section related to United States Department of Transportation (US DOT) Order 1050.2A, Title 49 Code of Federal Regulations (CFR) part 21, 23 United States Code (U.S.C.) 140 and 23 CFR part 200 (or 49 CFR 303, 49 U.S.C. 5332 or 49 U.S.C. 47123) are applicable to all North Carolina Department of Transportation (NCDOT) contracts and to all related subcontracts, material supply, engineering, architectural and other service contracts, regardless of dollar amount. Any Federal provision that is specifically required not specifically set forth is hereby incorporated by reference.

(1) **Title VI Assurances (USDOT Order 1050.2A, Appendix A)**

During the performance of this contract, the contractor, for itself, its assignees, and successors in interest (hereinafter referred to as the "contractor") agrees as follows:

(a) Compliance with Regulations

The contractor (hereinafter includes consultants) shall comply with the Acts and the Regulations relative to Nondiscrimination in Federally-assisted programs of the U.S. Department of Transportation, Federal Highway Administration (FHWA), as they may be amended from time to time, which are herein incorporated by reference and made a part of this contract.

(b) Nondiscrimination

The contractor, with regard to the work performed by it during the contract, shall not discriminate on the grounds of race, color, or national origin in the selection and retention of subcontractors, including procurements of materials and leases of equipment. The contractor shall not participate directly or indirectly in the discrimination prohibited by the Acts and the Regulations, including employment practices when the contract covers any activity, project, or program set forth in Appendix B of 49 CFR Part 21.

(c) Solicitations for Subcontractors, Including Procurements of Materials and Equipment

In all solicitations, either by competitive bidding, or negotiation made by the contractor for work to be performed under a subcontract, including procurements of materials, or leases of equipment, each potential subcontractor or supplier shall be notified by the contractor of the contractor's obligations under this contract and the Acts and the Regulations relative to Nondiscrimination on the grounds of race, color, or national origin.

(d) Information and Reports

The contractor shall provide all information and reports required by the Acts, the Regulations, and directives issued pursuant thereto and shall permit access to its books, records, accounts, other sources of information, and its facilities as may be determined by the Recipient or the FHWA to be pertinent to ascertain compliance with such Acts,

Regulations, and instructions. Where any information required of a contractor is in the exclusive possession of another who fails or refuses to furnish the information, the contractor shall so certify to the Recipient or the FHWA, as appropriate, and shall set forth what efforts it has made to obtain the information.

(e) Sanctions for Noncompliance:

In the event of a contractor's noncompliance with the Non-discrimination provisions of this contract, the Recipient will impose such contract sanctions as it and/or the FHWA may determine to be appropriate, including, but not limited to:

- (i) Withholding payments to the contractor under the contract until the contractor complies; and/or
- (ii) Cancelling, terminating, or suspending a contract, in whole or in part.

(f) Incorporation of Provisions

The contractor shall include the provisions of paragraphs (a) through (f) in every subcontract, including procurements of materials and leases of equipment, unless exempt by the Acts, the Regulations and directives issued pursuant thereto. The contractor shall take action with respect to any subcontract or procurement as the Recipient or the FHWA may direct as a means of enforcing such provisions including sanctions for noncompliance. Provided, that if the contractor becomes involved in, or is threatened with litigation by a subcontractor, or supplier because of such direction, the contractor may request the Recipient to enter into any litigation to protect the interests of the Recipient. In addition, the contractor may request the United States to enter into the litigation to protect the interests of the United States.

(2) **Title VI Nondiscrimination Program (23 CFR 200.5(p))**

The North Carolina Department of Transportation (NCDOT) has assured the USDOT that, as a condition to receiving federal financial assistance, NCDOT will comply with Title VI of the Civil Rights Act of 1964 and all requirements imposed by Title 49 CFR part 21 and related nondiscrimination authorities to ensure that no person shall, on the ground of race, color, national origin, limited English proficiency, sex, age, or disability (including religion/creed or income-level, where applicable), be excluded from participation in, be denied the benefits of, or be subjected to discrimination under any programs, activities, or services conducted or funded by NCDOT. Contractors and other organizations under contract or agreement with NCDOT must also comply with Title VI and related authorities, therefore:

(a) During the performance of this contract or agreement, contractors (e.g., subcontractors, consultants, vendors, prime contractors) are responsible for complying with NCDOT's Title VI Program. Contractors are not required to prepare or submit Title VI Programs. To comply with this section, the prime contractor shall:

1. Post NCDOT's Notice of Nondiscrimination and the Contractor's own Equal Employment Opportunity (EEO) Policy in conspicuous locations accessible to all employees, applicants and subcontractors on the jobsite.
2. Physically incorporate the required Title VI clauses into all subcontracts on federally-assisted and state-funded NCDOT projects, and ensure inclusion by subcontractors into all lower-tier subcontracts.
3. Required Solicitation Language. The Contractor shall include the following notification in all solicitations for bids and requests for work or material, regardless of funding source:

“The North Carolina Department of Transportation, in accordance with the provisions of Title VI of the Civil Rights Act of 1964 (78 Stat. 252, 42 U.S.C. §§



2000d to 2000d-4) and the Regulations, hereby notifies all bidders that it will affirmatively ensure that any contract entered into pursuant to this advertisement, disadvantaged business enterprises will be afforded full and fair opportunity to submit bids in response to this invitation and will not be discriminated against on the grounds of race, color, or national origin in consideration for an award. In accordance with other related nondiscrimination authorities, bidders and contractors will also not be discriminated against on the grounds of sex, age, disability, low-income level, creed/religion, or limited English proficiency in consideration for an award.”

4. Physically incorporate the FHWA-1273, in its entirety, into all subcontracts and subsequent lower tier subcontracts on Federal-aid highway construction contracts only.
  5. Provide language assistance services (i.e., written translation and oral interpretation), free of charge, to LEP employees and applicants. Contact NCDOT OCR for further assistance, if needed.
  6. For assistance with these Title VI requirements, contact the NCDOT Title VI Nondiscrimination Program at 1-800-522-0453.
- (b) Subrecipients (e.g. cities, counties, LGAs, planning organizations) may be required to prepare and submit a Title VI Plan to NCDOT, including Title VI Assurances and/or agreements. Subrecipients must also ensure compliance by their contractors and subrecipients with Title VI. (23 CFR 200.9(b)(7))
- (c) If reviewed or investigated by NCDOT, the contractor or subrecipient agrees to take affirmative action to correct any deficiencies found within a reasonable time period, not to exceed 90 calendar days, unless additional time is granted by NCDOT. (23 CFR 200.9(b)(15))
- (d) The Contractor is responsible for notifying subcontractors of NCDOT’s External Discrimination Complaints Process.
1. Applicability  
Title VI and related laws protect participants and beneficiaries (e.g., members of the public and contractors) from discrimination by NCDOT employees, subrecipients and contractors, regardless of funding source.
  2. Eligibility  
Any person—or class of persons—who believes he/she has been subjected to discrimination based on race, color, national origin, Limited English Proficiency (LEP), sex, age, or disability (and religion in the context of employment, aviation, or transit) may file a written complaint. The law also prohibits intimidation or retaliation of any sort.
  3. Time Limits and Filing Options  
Complaints may be filed by the affected individual(s) or a representative and must be filed no later than 180 calendar days after the following:
    - (i) The date of the alleged act of discrimination; or
    - (ii) The date when the person(s) became aware of the alleged discrimination; or
    - (iii) Where there has been a continuing course of conduct, the date on which that conduct was discontinued or the latest instance of the conduct.Title VI and related discrimination complaints may be submitted to the following entities:

- North Carolina Department of Transportation, Office of Civil Rights, Title VI Program, 1511 Mail Service Center, Raleigh, NC 27699-1511; toll free 1-800-522-0453
  - Federal Highway Administration, North Carolina Division Office, 310 New Bern Avenue, Suite 410, Raleigh, NC 27601, 919-747-7010
  - US Department of Transportation, Departmental Office of Civil Rights, External Civil Rights Programs Division, 1200 New Jersey Avenue, SE, Washington, DC 20590; 202-366-4070
4. Format for Complaints  
Complaints must be in writing and signed by the complainant(s) or a representative, and include the complainant's name, address, and telephone number. Complaints received by fax or e-mail will be acknowledged and processed. Allegations received by telephone will be reduced to writing and provided to the complainant for confirmation or revision before processing. Complaints will be accepted in other languages, including Braille.
5. Discrimination Complaint Form  
Contact NCDOT Civil Rights to receive a full copy of the Discrimination Complaint Form and procedures.
6. Complaint Basis  
Allegations must be based on issues involving race, color, national origin (LEP), sex, age, disability, or religion (in the context of employment, aviation or transit). "Basis" refers to the complainant's membership in a protected group category.

**TABLE 103-1  
COMPLAINT BASIS**

Protected Categories	Definition	Examples	Applicable Nondiscrimination Authorities
Race and Ethnicity	An individual belonging to one of the accepted racial groups; or the perception, based usually on physical characteristics that a person is a member of a racial group	Black/African American, Hispanic/Latino, Asian, American Indian/Alaska Native, Native Hawaiian/Pacific Islander, White	Title VI of the Civil Rights Act of 1964; 49 CFR Part 21; 23 CFR 200; 49 U.S.C. 5332(b); 49 U.S.C. 47123. ( <i>Executive Order 13166</i> )
Color	Color of skin, including shade of skin within a racial group	Black, White, brown, yellow, etc.	
National Origin ( <i>Limited English Proficiency</i> )	Place of birth. Citizenship is not a factor. ( <i>Discrimination based on language or a person's accent is also covered</i> )	Mexican, Cuban, Japanese, Vietnamese, Chinese	
Sex	Gender. The sex of an individual. <i>Note: Sex under this program does not include sexual orientation.</i>	Women and Men	1973 Federal-Aid Highway Act; 49 U.S.C. 5332(b); 49 U.S.C. 47123.
Age	Persons of any age	21-year-old person	Age Discrimination Act of 1975 49 U.S.C. 5332(b); 49 U.S.C. 47123.
Disability	Physical or mental impairment, permanent or temporary, or perceived.	Blind, alcoholic, para-amputee, epileptic, diabetic, arthritic	Section 504 of the Rehabilitation Act of 1973; Americans with Disabilities Act of 1990

<p>Religion (in the context of employment) <i>(Religion/ Creed in all aspects of any aviation or transit-related construction)</i></p>	<p>An individual belonging to a religious group; or the perception, based on distinguishable characteristics that a person is a member of a religious group. In practice, actions taken as a result of the moral and ethical beliefs as to what is right and wrong, which are sincerely held with the strength of traditional religious views. <b>Note:</b> Does not have to be associated with a recognized religious group or church; if an individual sincerely holds to the belief, it is a protected religious practice.</p>	<p>Muslim, Christian, Sikh, Hindu, etc.</p>	<p>Title VII of the Civil Rights Act of 1964; 23 CFR 230; FHWA-1273 Required Contract Provisions. <i>(49 U.S.C. 5332(b); 49 U.S.C. 47123)</i></p>
--	---	---	---

### (3) Pertinent Nondiscrimination Authorities

During the performance of this contract, the contractor, for itself, its assignees, and successors in interest agrees to comply with the following non-discrimination statutes and authorities, including, but not limited to:

- (a) Title VI of the Civil Rights Act of 1964 (42 U.S.C. § 2000d et seq., 78 stat. 252), (prohibits discrimination on the basis of race, color, national origin); and 49 CFR Part 21.
- (b) The Uniform Relocation Assistance and Real Property Acquisition Policies Act of 1970, (42 U.S.C. § 4601), (prohibits unfair treatment of persons displaced or whose property has been acquired because of Federal or Federal-aid programs and projects);
- (c) Federal-Aid Highway Act of 1973, (23 U.S.C. § 324 et seq.), (prohibits discrimination on the basis of sex);
- (d) Section 504 of the Rehabilitation Act of 1973, (29 U.S.C. § 794 et seq.), as amended, (prohibits discrimination on the basis of disability) and 49 CFR Part 27;
- (e) The Age Discrimination Act of 1975, as amended, (42 U.S.C. § 6101 et seq.), (prohibits discrimination on the basis of age);
- (f) Airport and Airway Improvement Act of 1982, (49 USC § 471, Section 47123), as amended, (prohibits discrimination based on race, creed, color, national origin, or sex);
- (g) The Civil Rights Restoration Act of 1987, (PL 100-209), (Broadened the scope, coverage and applicability of Title VI of the Civil Rights Act of 1964, The Age Discrimination Act of 1975 and Section 504 of the Rehabilitation Act of 1973, by expanding the definition of the terms "programs or activities" to include all of the programs or activities of the Federal-aid recipients, sub-recipients and contractors, whether such programs or activities are Federally funded or not);
- (h) Titles II and III of the Americans with Disabilities Act, which prohibit discrimination on the basis of disability in the operation of public entities, public and private transportation systems, places of public accommodation, and certain testing entities (42 U.S.C. §§ 12131-12189) as implemented by Department of Transportation regulations at 49 C.F.R. parts 37 and 38;
- (i) The Federal Aviation Administration's Nondiscrimination statute (49 U.S.C. § 47123) (prohibits discrimination on the basis of race, color, national origin, and sex);
- (j) Executive Order 12898, Federal Actions to Address Environmental Justice in Minority Populations and Low-Income Populations, which ensures Nondiscrimination against minority populations by discouraging programs, policies, and activities with

- disproportionately high and adverse human health or environmental effects on minority and low-income populations;
- (k) Executive Order 13166, Improving Access to Services for Persons with Limited English Proficiency, and resulting agency guidance, national origin discrimination includes discrimination because of Limited English proficiency (LEP). To ensure compliance with Title VI, you must take reasonable steps to ensure that LEP persons have meaningful access to your programs (70 Fed. Reg. at 74087 to 74100);
  - (l) Title IX of the Education Amendments of 1972, as amended, which prohibits you from discriminating because of sex in education programs or activities (20 U.S.C. 1681 et seq).
  - (m) Title VII of the Civil Rights Act of 1964 (42 U.S.C. § 2000e et seq., Pub. L. 88-352), (prohibits employment discrimination on the basis of race, color, religion, sex, or national origin).
- (4) **Additional Title VI Assurances**

*\*\*The following Title VI Assurances (Appendices B, C and D) shall apply, as applicable*

- (a) Clauses for Deeds Transferring United States Property (1050.2A, Appendix B)  
The following clauses will be included in deeds effecting or recording the transfer of real property, structures, or improvements thereon, or granting interest therein from the United States pursuant to the provisions of Assurance 4.

NOW, THEREFORE, the U.S. Department of Transportation as authorized by law and upon the condition that the North Carolina Department of Transportation (NCDOT) will accept title to the lands and maintain the project constructed thereon in accordance with the North Carolina General Assembly, the Regulations for the Administration of the Federal-Aid Highway Program, and the policies and procedures prescribed by the Federal Highway Administration of the U.S. Department of Transportation in accordance and in compliance with all requirements imposed by Title 49, Code of Federal Regulations, U.S. Department of Transportation, Subtitle A, Office of the Secretary, Part 21, Nondiscrimination in Federally-assisted programs of the U.S. Department of Transportation pertaining to and effectuating the provisions of Title VI of the Civil Rights Act of 1964 (78 Stat. 252; 42 U.S.C. § 2000d to 2000d-4), does hereby remise, release, quitclaim and convey unto the NCDOT all the right, title and interest of the U.S. Department of Transportation in and to said lands described in Exhibit A attached hereto and made a part hereof.

(HABENDUM CLAUSE)

TO HAVE AND TO HOLD said lands and interests therein unto the North Carolina Department of Transportation (NCDOT) and its successors forever, subject, however, to the covenants, conditions, restrictions and reservations herein contained as follows, which will remain in effect for the period during which the real property or structures are used for a purpose for which Federal financial assistance is extended or for another purpose involving the provision of similar services or benefits and will be binding on the NCDOT, its successors and assigns.

The NCDOT, in consideration of the conveyance of said lands and interests in lands, does hereby covenant and agree as a covenant running with the land for itself, its successors and assigns, that (1) no person will on the grounds of race, color, or national origin, be excluded from participation in, be denied the benefits of, or be otherwise subjected to discrimination with regard to any facility located wholly or in part on, over, or under such lands hereby conveyed [,] [and]\* (2) that the NCDOT will use the lands and interests in lands and interests in lands so conveyed, in compliance with all requirements imposed by or pursuant to Title 49, Code of Federal Regulations, U.S. Department of Transportation, Subtitle A, Office of the Secretary, Part 21, Non-discrimination in Federally-assisted programs of the U.S. Department of Transportation, Effectuation of Title VI of the Civil Rights Act of 1964, and as said Regulations and Acts may be amended [,] and (3) that in the event of breach of any of the above-mentioned nondiscrimination conditions, the Department will have a right to enter or re-enter said lands and facilities on said land, and that above described land and facilities will thereon revert to and vest in and become the absolute property of the U.S. Department of Transportation and its assigns as such interest existed prior to this instruction].\*

(\*Reverter clause and related language to be used only when it is determined that such a clause is necessary in order to make clear the purpose of Title VI.)

(b) Clauses for Transfer of Real Property Acquired or Improved Under the Activity, Facility, or Program (1050.2A, Appendix C)

The following clauses will be included in deeds, licenses, leases, permits, or similar instruments entered into by the North Carolina Department of Transportation (NCDOT) pursuant to the provisions of Assurance 7(a):

1. The (grantee, lessee, permittee, etc. as appropriate) for himself/herself, his/her heirs, personal representatives, successors in interest, and assigns, as a part of the consideration hereof, does hereby covenant and agree [in the case of deeds and leases add "as a covenant running with the land"] that:
  - (i.) In the event facilities are constructed, maintained, or otherwise operated on the property described in this (deed, license, lease, permit, etc.) for a purpose for which a U.S. Department of Transportation activity, facility, or program is extended or for another purpose involving the provision of similar services or benefits, the (grantee, licensee, lessee, permittee, etc.) will maintain and operate such facilities and services in compliance with all requirements imposed by the Acts and Regulations (as may be amended) such that no person on the grounds of race, color, or national origin, will be excluded from participation in, denied the benefits of, or be otherwise subjected to discrimination in the use of said facilities.
2. With respect to licenses, leases, permits, etc., in the event of breach of any of the above Nondiscrimination covenants, the NCDOT will have the right to terminate the (lease, license, permit, etc.) and to enter, re-enter, and repossess said lands and facilities thereon, and hold the same as if the (lease, license, permit, etc.) had never been made or issued. \*
3. With respect to a deed, in the event of breach of any of the above Nondiscrimination covenants, the NCDOT will have the right to enter or re-enter the lands and facilities thereon, and the above described lands and facilities will there upon revert to and vest in and become the absolute property of the NCDOT and its assigns. \*

- (\*Reverter clause and related language to be used only when it is determined that such a clause is necessary to make clear the purpose of Title VI.)
- (c) Clauses for Construction/Use/Access to Real Property Acquired Under the Activity, Facility or Program (1050.2A, Appendix D)

The following clauses will be included in deeds, licenses, permits, or similar instruments/ agreements entered into by the North Carolina Department of Transportation (NCDOT) pursuant to the provisions of Assurance 7(b):

1. The (grantee, licensee, permittee, etc., as appropriate) for himself/herself, his/her heirs, personal representatives, successors in interest, and assigns, as a part of the consideration hereof, does hereby covenant and agree (in the case of deeds and leases add, "as a covenant running with the land") that (1) no person on the ground of race, color, or national origin, will be excluded from participation in, denied the benefits of, or be otherwise subjected to discrimination in the use of said facilities, (2) that in the construction of any improvements on, over, or under such land, and the furnishing of services thereon, no person on the ground of race, color, or national origin, will be excluded from participation in, denied the benefits of, or otherwise be subjected to discrimination, (3) that the (grantee, licensee, lessee, permittee, etc.) will use the premises in compliance with all other requirements imposed by or pursuant to the Acts and Regulations, as amended, set forth in this Assurance.
2. With respect to (licenses, leases, permits, etc.), in the event of breach of any of the above Non- discrimination covenants, the NCDOT will have the right to terminate the (license, permit, etc., as appropriate) and to enter or re-enter and repossess said land and the facilities thereon, and hold the same as if said (license, permit, etc., as appropriate) had never been made or issued. \*
3. With respect to deeds, in the event of breach of any of the above Nondiscrimination covenants, the NCDOT will there upon revert to and vest in and become the absolute property of the NCDOT and its assigns. \*

(\*Reverter clause and related language to be used only when it is determined that such a clause is necessary to make clear the purpose of Title VI.)

**STANDARD SPECIAL PROVISION****ON-THE-JOB TRAINING**

(10-16-07) (Rev. 4-21-15)

Z-10

**Description**

The North Carolina Department of Transportation will administer a custom version of the Federal On-the-Job Training (OJT) Program, commonly referred to as the Alternate OJT Program. All contractors (existing and newcomers) will be automatically placed in the Alternate Program. Standard OJT requirements typically associated with individual projects will no longer be applied at the project level. Instead, these requirements will be applicable on an annual basis for each contractor administered by the OJT Program Manager.

On the Job Training shall meet the requirements of 23 CFR 230.107 (b), 23 USC – Section 140, this provision and the On-the-Job Training Program Manual.

The Alternate OJT Program will allow a contractor to train employees on Federal, State and privately funded projects located in North Carolina. However, priority shall be given to training employees on NCDOT Federal-Aid funded projects.

**Minorities and Women**

Developing, training and upgrading of minorities and women toward journeyman level status is a primary objective of this special training provision. Accordingly, the Contractor shall make every effort to enroll minority and women as trainees to the extent that such persons are available within a reasonable area of recruitment. This training commitment is not intended, and shall not be used, to discriminate against any applicant for training, whether a member of a minority group or not.

**Assigning Training Goals**

The Department, through the OJT Program Manager, will assign training goals for a calendar year based on the contractors' past three years' activity and the contractors' anticipated upcoming year's activity with the Department. At the beginning of each year, all contractors eligible will be contacted by the Department to determine the number of trainees that will be assigned for the upcoming calendar year. At that time the Contractor shall enter into an agreement with the Department to provide a self-imposed on-the-job training program for the calendar year. This agreement will include a specific number of annual training goals agreed to by both parties. The number of training assignments may range from 1 to 15 per contractor per calendar year. The Contractor shall sign an agreement to fulfill their annual goal for the year.\

### **Training Classifications**

The Contractor shall provide on-the-job training aimed at developing full journeyman level workers in the construction craft/operator positions. Preference shall be given to providing training in the following skilled work classifications:

Equipment Operators	Office Engineers
Truck Drivers	Estimators
Carpenters	Iron / Reinforcing Steel Workers
Concrete Finishers	Mechanics
Pipe Layers	Welders

The Department has established common training classifications and their respective training requirements that may be used by the contractors. However, the classifications established are not all-inclusive. Where the training is oriented toward construction applications, training will be allowed in lower-level management positions such as office engineers and estimators. Contractors shall submit new classifications for specific job functions that their employees are performing. The Department will review and recommend for acceptance to FHWA the new classifications proposed by contractors, if applicable. New classifications shall meet the following requirements:

Proposed training classifications are reasonable and realistic based on the job skill classification needs, and

The number of training hours specified in the training classification is consistent with common practices and provides enough time for the trainee to obtain journeyman level status.

The Contractor may allow trainees to be trained by a subcontractor provided that the Contractor retains primary responsibility for meeting the training and this provision is made applicable to the subcontract. However, only the Contractor will receive credit towards the annual goal for the trainee.

Where feasible, 25 percent of apprentices or trainees in each occupation shall be in their first year of apprenticeship or training. The number of trainees shall be distributed among the work classifications on the basis of the contractor's needs and the availability of journeymen in the various classifications within a reasonable area of recruitment.

No employee shall be employed as a trainee in any classification in which they have successfully completed a training course leading to journeyman level status or in which they have been employed as a journeyman.

### **Records and Reports**

The Contractor shall maintain enrollment, monthly and completion reports documenting company compliance under these contract documents. These documents and any other information as requested shall be submitted to the OJT Program Manager.



Upon completion and graduation of the program, the Contractor shall provide each trainee with a certification Certificate showing the type and length of training satisfactorily completed.

**Trainee Interviews**

All trainees enrolled in the program will receive an initial and Trainee/Post graduate interview conducted by the OJT program staff.

**Trainee Wages**

Contractors shall compensate trainees on a graduating pay scale based upon a percentage of the prevailing minimum journeyman wages (Davis-Bacon Act). Minimum pay shall be as follows:

60 percent	of the journeyman wage for the first half of the training period
75 percent	of the journeyman wage for the third quarter of the training period
90 percent	of the journeyman wage for the last quarter of the training period

In no instance shall a trainee be paid less than the local minimum wage. The Contractor shall adhere to the minimum hourly wage rate that will satisfy both the NC Department of Labor (NCDOL) and the Department.

**Achieving or Failing to Meet Training Goals**

The Contractor will be credited for each trainee employed by him on the contract work who is currently enrolled or becomes enrolled in an approved program and who receives training for at least 50 percent of the specific program requirement. Trainees will be allowed to be transferred between projects if required by the Contractor's scheduled workload to meet training goals.

If a contractor fails to attain their training assignments for the calendar year, they may be taken off the NCDOT's Bidders List.

**Measurement and Payment**

No compensation will be made for providing required training in accordance with these contract documents.

**Project Special Provisions  
Erosion Control**

**STABILIZATION REQUIREMENTS:**

(4-30-2019)

Stabilization for this project shall comply with the time frame guidelines as specified by the NCG-010000 general construction permit effective April 1, 2019 issued by the North Carolina Department of Environmental Quality Division of Water Resources. Temporary or permanent ground cover stabilization shall occur within 7 calendar days from the last land-disturbing activity, with the following exceptions in which temporary or permanent ground cover shall be provided in 14 calendar days from the last land-disturbing activity:

- Slopes between 2:1 and 3:1, with a slope length of 10 ft. or less
- Slopes 3:1 or flatter, with a slope of length of 50 ft. or less
- Slopes 4:1 or flatter

The stabilization timeframe for High Quality Water (HQW) Zones shall be 7 calendar days with no exceptions for slope grades or lengths. High Quality Water Zones (HQW) Zones are defined by North Carolina Administrative Code 15A NCAC 04A.0105 (25). Temporary and permanent ground cover stabilization shall be achieved in accordance with the provisions in this contract and as directed.

**SEEDING AND MULCHING:**

**(East)**

The kinds of seed and fertilizer, and the rates of application of seed, fertilizer, and limestone, shall be as stated below. During periods of overlapping dates, the kind of seed to be used shall be determined. All rates are in pounds per acre.

All Roadway Areas

<b>March 1 - August 31</b>		<b>September 1 - February 28</b>	
50#	Tall Fescue	50#	Tall Fescue
10#	Centipede	10#	Centipede
25#	Bermudagrass (hulled)	35#	Bermudagrass (unhulled)
500#	Fertilizer	500#	Fertilizer
4000#	Limestone	4000#	Limestone

Waste and Borrow Locations

<b>March 1 – August 31</b>		<b>September 1 - February 28</b>	
75#	Tall Fescue	75#	Tall Fescue
25#	Bermudagrass (hulled)	35#	Bermudagrass (unhulled)
500#	Fertilizer	500#	Fertilizer
4000#	Limestone	4000#	Limestone

Note: 50# of Bahiagrass may be substituted for either Centipede or Bermudagrass only upon Engineer's request.

### Approved Tall Fescue Cultivars

06 Dust	Escalade	Justice	Serengeti
2 <sup>nd</sup> Millennium	Essential	Kalahari	Shelby
3 <sup>rd</sup> Millennium	Evergreen 2	Kitty Hawk 2000	Sheridan
Apache III	Falcon IV	Legitimate	Signia
Avenger	Falcon NG	Lexington	Silver Hawk
Barlexas	Falcon V	LSD	Sliverstar
Barlexas II	Faith	Magellan	Shenandoah Elite
Bar Fa	Fat Cat	Matador	Sidewinder
Barrera	Festnova	Millennium SRP	Skyline
Barrington	Fidelity	Monet	Solara
Barrobusto	Finelawn Elite	Mustang 4	Southern Choice II
Barvado	Finelawn Xpress	Ninja 2	Speedway
Biltmore	Finesse II	Ol' Glory	Spyder LS
Bingo	Firebird	Olympic Gold	Sunset Gold
Bizem	Firecracker LS	Padre	Taccoa
Blackwatch	Fireza	Patagonia	Tanzania
Blade Runner II	Five Point	Pedigree	Trio
Bonsai	Focus	Picasso	Tahoe II
Braveheart	Forte	Piedmont	Talladega
Bravo	Garrison	Plantation	Tarheel
Bullseye	Gazelle II	Proseeds 5301	Terrano
Cannavaro	Gold Medallion	Prospect	Titan ltd
Catalyst	Grande 3	Pure Gold	Titanium LS
Cayenne	Greenbrooks	Quest	Tracer
Cessane Rz	Greenkeeper	Raptor II	Traverse SRP
Chipper	Gremlin	Rebel Exeda	Tulsa Time
Cochise IV	Greystone	Rebel Sentry	Turbo
Constitution	Guardian 21	Rebel IV	Turbo RZ
Corgi	Guardian 41	Regiment II	Tuxedo RZ
Corona	Hemi	Regenerate	Ultimate
Coyote	Honky Tonk	Rendition	Venture
Darlington	Hot Rod	Rhambler 2 SRP	Umbrella
Davinci	Hunter	Rembrandt	Van Gogh
Desire	Inferno	Reunion	Watchdog
Dominion	Innovator	Riverside	Wolfpack II
Dynamic	Integrity	RNP	Xtremegreen
Dynasty	Jaguar 3	Rocket	
Endeavor	Jamboree	Scorpion	

On cut and fill slopes 2:1 or steeper Centipede shall be applied at the rate of 5 pounds per acre and add 20# of Sericea Lespedeza from January 1 - December 31.

Fertilizer shall be 10-20-20 analysis. A different analysis of fertilizer may be used provided the 1-2-2 ratio is maintained and the rate of application adjusted to provide the same amount of plant food as a 10-20-20 analysis and as directed.

**TEMPORARY SEEDING:**

Fertilizer shall be the same analysis as specified for *Seeding and Mulching* and applied at the rate of 400 pounds and seeded at the rate of 50 pounds per acre. Sweet Sudan Grass, German Millet or Browntop Millet shall be used in summer months and Rye Grain during the remainder of the year. The Engineer will determine the exact dates for using each kind of seed.

**FERTILIZER TOPDRESSING:**

Fertilizer used for topdressing on all roadway areas except slopes 2:1 and steeper shall be 10-20-20 grade and shall be applied at the rate of 500 pounds per acre. A different analysis of fertilizer may be used provided the 1-2-2 ratio is maintained and the rate of application adjusted to provide the same amount of plant food as 10-20-20 analysis and as directed.

Fertilizer used for topdressing on slopes 2:1 and steeper and waste and borrow areas shall be 16-8-8 grade and shall be applied at the rate of 500 pounds per acre. A different analysis of fertilizer may be used provided the 2-1-1 ratio is maintained and the rate of application adjusted to provide the same amount of plant food as 16-8-8 analysis and as directed.

**SUPPLEMENTAL SEEDING:**

The kinds of seed and proportions shall be the same as specified for *Seeding and Mulching*, with the exception that no centipede seed will be used in the seed mix for supplemental seeding. The rate of application for supplemental seeding may vary from 25# to 75# per acre. The actual rate per acre will be determined prior to the time of topdressing and the Contractor will be notified in writing of the rate per acre, total quantity needed, and areas on which to apply the supplemental seed. Minimum tillage equipment, consisting of a sod seeder shall be used for incorporating seed into the soil as to prevent disturbance of existing vegetation. A clodbuster (ball and chain) may be used where degree of slope prevents the use of a sod seeder.

**MOWING:**

The minimum mowing height on this project shall be 4 inches.

**TACK FOR MULCH FOR EROSION CONTROL:**  
(07-19-22)

**Description**

This work consists of supplying and installing of an approved material for binding mulch for erosion control in accordance with Section 1060-5, Section 1615 and Section 1660 of the *Standard Specifications*. This provision defines acceptable materials and rates for tacking material for holding mulch in place.

**Materials**

(a) Emulsified Asphalt

Asphalt emulsion tack shall conform to the requirements of AASHTO M 140, Specification for Emulsified Asphalt. The emulsified asphalt may be rapid setting, medium setting, or slow setting. Apply emulsified asphalt tackifier at a rate of 0.10 gallons per square yard (approximately 484 gallons per acre).

(b) Cellulose Hydromulch

Cellulose hydromulch products shall be non-toxic, weed-free, prepackaged cellulose fiber (pulp) material containing no more than 3% ash or other inert materials. Cellulose hydromulches may contain dyes or binders specifically formulated to enhance the adhesive qualities of the hydromulch. Apply cellulose hydromulches at a rate of 1000 pounds (dry weight) per acre.

Wood fiber or wood fiber blend hydromulches may be substituted for cellulose hydromulch at the same application rate.

(c) Other tackifiers

Other approved materials, specifically designed and manufactured for application as a straw mulch tacking agent, may be used at the manufacturer's recommended rate.

**Construction Methods**

Apply the Tack for Mulch for Erosion Control uniformly across straw mulch per Section 1615 and Section 1660 of the *Standard Specifications*.

**Payment**

*Tack for Mulch for Erosion Control* is incidental to the application of *Temporary Mulching*, Section 1615-4, and *Seeding and Mulching*, Section 1660-8, and no additional payment will be made.

**Project Special Provisions  
Structures  
Table of Contents**

<b>Special Provision</b>		<b>Page</b>
Scope of Work		BP-3
Falsework and Formwork	(02-14-22)	BP-4
Submittal of Working Drawings	(02-14-22)	BP-11
Crane Safety	(06-20-19)	BP-17
Grout for Structures	(12-01-17)	BP-17
Shotcrete Repairs	(08-08-22)	BP-18
Concrete Repairs	(02-11-19)	BP-23
Painting Existing Weathering Steel Structures	(02-11-19)	BP-26
Painting Existing Structure	(02-11-19)	BP-40
Foam Joint Seals for Preservation	(SPECIAL)	BP-52
Pourable Silicone Joint Sealant	(SPECIAL)	BP-56
Expansion Joint Seal for Preservation	(SPECIAL)	BP-58
Epoxy Coating and Debris Removal	(SPECIAL)	BP-63
Concrete for Deck Repair	(05-19-23)	BP-64
Volumetric Mixer	(12-18-12)	BP-65
Epoxy Resin Injection	(08-08-22)	BP-67
Silane Deck Treatment	(SPECIAL)	BP-72
Concrete Deck Repair for Silane Deck Treatment	(SPECIAL)	BP-77
Silane Barrier Rail Treatment	(SPECIAL)	BP-78
Epoxy Coating Concrete Girder Ends	(SPECIAL)	BP-83
Bridge Joint Demolition	(SPECIAL)	BP-85
Slope Protection Void Filling	(SPECIAL)	BP-86
Diamond Grinding Concrete Approach Slabs	(SPECIAL)	BP-88

15BPR.124.3

## BP-2

Durham/Wake County

Saw Cutting Concrete Barrier Rail	(SPECIAL)	BP-90
Modular Expansion Joint Seals for Preservation	(SPECIAL)	BP-91
Elastomeric Concrete for Preservation	(02-11-19)	BP-95
3 Bar Metal Rail Repair	(SPECIAL)	BP-97
Repairs to Prestressed Concrete Girders	(SPECIAL)	BP-98
Thermal Sprayed Coatings (Metallization)	(12-01-17)	BP-102
Protection of Railway Interest	(SPECIAL)	BP-103



07/05/2023

**STRUCTURE PROJECT SPECIAL PROVISIONS****SCOPE OF WORK**

This work shall consist of furnishing all labor, equipment, and materials to seal the existing bridge deck, sidewalks and concrete median island with silane, repair substructure elements, epoxy coat prestressed girders ends, and clean and paint structural steel as directed in the plans. Work includes: portable lighting; existing bridge deck surface preparation by shotblasting the existing bridge deck; surface preparation for silane treatment on concrete barriers; application of silane deck treatment to the prepared bridge deck and barrier rails; bridge joint demolition; installation of elastomeric concrete joint headers; installation of expansion joint gland material and foam joint seals; substructure repair using concrete, shotcrete, and epoxy coating; removal, containment, and disposal of the existing structural steel paint systems; preparation of the surface to be painted and application of the new structural steel paint systems; disposal of demolition and waste material; approach pavement milling and paving; diamond grinding approach slabs to top of deck elevation; foam filling of voids beneath end bent caps; seeding and mulching all grassed areas disturbed; and all incidental items necessary to complete the project as specified and shown on the plans. No separate measurement or payment will be made for seeding, mulching, or any measures required to control erosion or prevent off-site sedimentation. The cost of this work shall be included in the lump sum price bid for Mobilization.

Work will be performed on the existing bridge at the following locations:

- 1.) Durham County Bridge #306 – SR 1118 (Fayetteville Rd.) over I-40
- 2.) Wake County Bridge #1039 – SR 2517 (Rogers Ln.) over I-87/US64/US264, Crabtree Creek and NS Railroad
- 3.) Wake County Bridge #1083 – NC-98 over US-1 (Capital Blvd.)
- 4.) Wake County Bridge #1084 – NC-98 over Richland Creek

The contractor shall provide all necessary access; underdeck platforms, scaffolding, ladders, etc.; provide all traffic control; provide all staging areas, material storage, waste disposal; provide environmental controls to limit loss of materials from sawing equipment, and chipping equipment; and all else necessary to complete the work.

The contractor shall be responsible for fulfilling all requirements of the NCDOT Standard Specifications for Roads and Structures dated January 2018, except as otherwise specified herein.



**FALSEWORK AND FORMWORK****(2-14-22)****1.0 DESCRIPTION**

Use this Special Provision as a guide to develop temporary works submittals required by the Standard Specifications or other provisions; no additional submittals are required herein. Such temporary works include, but are not limited to, falsework and formwork.

Falsework is any temporary construction used to support the permanent structure until it becomes self-supporting. Formwork is the temporary structure or mold used to retain plastic or fluid concrete in its designated shape until it hardens. Access scaffolding is a temporary structure that functions as a work platform that supports construction personnel, materials, and tools, but is not intended to support the structure. Scaffolding systems that are used to temporarily support permanent structures (as opposed to functioning as work platforms) are considered to be falsework under the definitions given. Shoring is a component of falsework such as horizontal, vertical, or inclined support members. Where the term “temporary works” is used, it includes all of the temporary facilities used in bridge construction that do not become part of the permanent structure.

Design and construct safe and adequate temporary works that will support all loads imposed and provide the necessary rigidity to achieve the lines and grades shown on the plans in the final structure.

**2.0 MATERIALS**

Select materials suitable for temporary works; however, select materials that also ensure the safety and quality required by the design assumptions. The Engineer has authority to reject material on the basis of its condition, inappropriate use, safety, or nonconformance with the plans. Clearly identify allowable loads or stresses for all materials or manufactured devices on the plans. Revise the plan and notify the Engineer if any change to materials or material strengths is required.

**3.0 DESIGN REQUIREMENTS****A. Working Drawings**

Provide working drawings for items as specified in the contract, or as required by the Engineer, with design calculations and supporting data in sufficient detail to permit a structural and safety review of the proposed design of the temporary work.

On the drawings, show all information necessary to allow the design of any component to be checked independently as determined by the Engineer.

When concrete placement is involved, include data such as the drawings of proposed sequence, rate of placement, direction of placement, and location of all construction joints.

When required, have the drawings and calculations prepared under the guidance of, and sealed by, a North Carolina Registered Professional Engineer who is knowledgeable in temporary works design.

If requested by the Engineer, submit with the working drawings manufacturer's catalog data listing the weight of all construction equipment that will be supported on the temporary work. Show anticipated total settlements and/or deflections of falsework and forms on the working drawings. Include falsework footing settlements, joint take-up, and deflection of beams or girders.

As an option for the Contractor, overhang falsework hangers may be uniformly spaced, at a maximum of 36 inches, provided the following conditions are met:

Member Type (PCG)	Member Depth, (inches)	Max. Overhang Width, (inches)	Max. Slab Edge Thickness, (inches)	Max. Screenshot Wheel Weight, (lbs.)	Bracket Min. Vertical Leg Extension, (inches)
II	36	39	14	2000	26
III	45	42	14	2000	35
IV	54	45	14	2000	44
MBT	63	51	12	2000	50
MBT	72	55	12	1700	48

Overhang width is measured from the centerline of the girder to the edge of the deck slab. For Type II, III & IV prestressed concrete girders (PCG), 45-degree cast-in-place half hangers and rods must have a minimum safe working load of 6,000 lbs.

For MBT prestressed concrete girders, 45-degree angle holes for falsework hanger rods shall be cast through the girder top flange and located, measuring along the top of the member, 1'-2 1/2" from the edge of the top flange. Hanger hardware and rods must have a minimum safe working load of 6,000 lbs.

For links slabs, the tops of girders directly beneath the link slab shall be free of overhang falsework attachments or other hardware. Submit calculations and working drawings for overhang falsework in the link slab region.

The overhang bracket provided for the diagonal leg shall have a minimum safe working load of 3,750 lbs. The vertical leg of the bracket shall extend to the point that the heel bears on the girder

bottom flange, no closer than 4 inches from the bottom of the member. However, for 72-inch members, the heel of the bracket shall bear on the web, near the bottom flange transition.

Provide adequate overhang falsework and determine the appropriate adjustments for deck geometry, equipment, casting procedures and casting conditions.

If the optional overhang falsework spacing is used, indicate this on the falsework submittal and advise the girder producer of the proposed details. Failure to notify the Engineer of hanger type and hanger spacing on prestressed concrete girder casting drawings may delay the approval of those drawings.

Falsework hangers that support concentrated loads and are installed at the edge of thin top flange concrete girders (such as bulb tee girders) shall be spaced so as not to exceed 75% of the manufacturer's stated safe working load. Use of dual leg hangers (such as Meadow Burke HF-42 and HF-43) are not allowed on concrete girders with thin top flanges. Design the falsework and forms supporting deck slabs and overhangs on girder bridges so that there will be no differential settlement between the girders and the deck forms during placement of deck concrete.

When staged construction of the bridge deck is required, detail falsework and forms for screed and fluid concrete loads to be independent of any previous deck pour components when the mid-span girder deflection due to deck weight is greater than  $\frac{3}{4}$ ".

Note on the working drawings any anchorages, connectors, inserts, steel sleeves or other such devices used as part of the falsework or formwork that remains in the permanent structure. If the plan notes indicate that the structure contains the necessary corrosion protection required for a Corrosive Site, epoxy coat, galvanize or metalize these devices. Electroplating will not be allowed. Any coating required by the Engineer will be considered incidental to the various pay items requiring temporary works.

Design falsework and formwork requiring submittals in accordance with the 1995 AASHTO *Guide Design Specifications for Bridge Temporary Works* except as noted herein.

1. Wind Loads

Table 2.2 of Article 2.2.5.1 is modified to include wind velocities up to 110 mph. In addition, Table 2.2A is included to provide the maximum wind speeds by county in North Carolina.

**Table 2.2 - Wind Pressure Values**

Height Zone feet above ground	Pressure, lb/ft <sup>2</sup> for Indicated Wind Velocity, mph				
	70	80	90	100	110
0 to 30	15	20	25	30	35
30 to 50	20	25	30	35	40
50 to 100	25	30	35	40	45
over 100	30	35	40	45	50

2. Time of Removal

The following requirements replace those of Article 3.4.8.2.

Do not remove forms until the concrete has attained strengths required in Article 420-16 of the Standard Specifications and these Special Provisions.

Do not remove forms until the concrete has sufficient strength to prevent damage to the surface.

**Table 2.2A - Steady State Maximum Wind Speeds by Counties in North Carolina**

COUNTY	25 YR (mph)	COUNTY	25 YR (mph)	COUNTY	25 YR (mph)
Alamance	70	Franklin	70	Pamlico	100
Alexander	70	Gaston	70	Pasquotank	100
Alleghany	70	Gates	90	Pender	100
Anson	70	Graham	80	Perquimans	100
Ashe	70	Granville	70	Person	70
Avery	70	Greene	80	Pitt	90
Beaufort	100	Guilford	70	Polk	80
Bertie	90	Halifax	80	Randolph	70
Bladen	90	Harnett	70	Richmond	70
Brunswick	100	Haywood	80	Robeson	80
Buncombe	80	Henderson	80	Rockingham	70
Burke	70	Hertford	90	Rowan	70
Cabarrus	70	Hoke	70	Rutherford	70
Caldwell	70	Hyde	110	Sampson	90
Camden	100	Iredell	70	Scotland	70
Carteret	110	Jackson	80	Stanley	70
Caswell	70	Johnston	80	Stokes	70
Catawba	70	Jones	100	Surry	70
Cherokee	80	Lee	70	Swain	80
Chatham	70	Lenoir	90	Transylvania	80
Chowan	90	Lincoln	70	Tyrell	100
Clay	80	Macon	80	Union	70
Cleveland	70	Madison	80	Vance	70
Columbus	90	Martin	90	Wake	70
Craven	100	McDowell	70	Warren	70
Cumberland	80	Mecklenburg	70	Washington	100
Currituck	100	Mitchell	70	Watauga	70
Dare	110	Montgomery	70	Wayne	80
Davidson	70	Moore	70	Wilkes	70
Davie	70	Nash	80	Wilson	80
Duplin	90	New Hanover	100	Yadkin	70
Durham	70	Northampton	80	Yancey	70
Edgecombe	80	Onslow	100		
Forsyth	70	Orange	70		

## B. Review and Approval

The Engineer is responsible for the review and approval of temporary works' drawings.

Submit the working drawings sufficiently in advance of proposed use to allow for their review, revision (if needed), and approval without delay to the work.

The time period for review of the working drawings does not begin until complete drawings and design calculations, when required, are received by the Engineer.

Do not start construction of any temporary work for which working drawings are required until the drawings have been approved. Such approval does not relieve the Contractor of the responsibility for the accuracy and adequacy of the working drawings.

## 4.0 CONSTRUCTION REQUIREMENTS

All requirements of Section 420 of the Standard Specifications apply.

Construct temporary works in conformance with the approved working drawings. Ensure that the quality of materials and workmanship employed is consistent with that assumed in the design of the temporary works. Do not weld falsework members to any portion of the permanent structure unless approved. Show any welding to the permanent structure on the approved construction drawings.

Provide tell-tales attached to the forms and extending to the ground, or other means, for accurate measurement of falsework settlement. Make sure that the anticipated compressive settlement and/or deflection of falsework does not exceed 1 inch. For cast-in-place concrete structures, make sure that the calculated deflection of falsework flexural members does not exceed 1/240 of their span regardless of whether or not the deflection is compensated by camber strips.

### A. Maintenance and Inspection

Inspect and maintain the temporary work in an acceptable condition throughout the period of its use. Certify that the manufactured devices have been maintained in a condition to allow them to safely carry their rated loads. Clearly mark each piece so that its capacity can be readily determined at the job site.

Perform an in-depth inspection of an applicable portion(s) of the temporary works, in the presence of the Engineer, not more than 24 hours prior to the beginning of each concrete placement. Inspect other temporary works at least once a month to ensure that they are

functioning properly. Have a North Carolina Registered Professional Engineer inspect the cofferdams, shoring, sheathing, support of excavation structures, and support systems for load tests prior to loading.

#### B. Foundations

Determine the safe bearing capacity of the foundation material on which the supports for temporary works rest. If required by the Engineer, conduct load tests to verify proposed bearing capacity values that are marginal or in other high-risk situations.

The use of the foundation support values shown on the contract plans of the permanent structure is permitted if the foundations are on the same level and on the same soil as those of the permanent structure.

Allow for adequate site drainage or soil protection to prevent soil saturation and washout of the soil supporting the temporary works supports.

If piles are used, the estimation of capacities and later confirmation during construction using standard procedures based on the driving characteristics of the pile is permitted. If preferred, use load tests to confirm the estimated capacities; or, if required by the Engineer conduct load tests to verify bearing capacity values that are marginal or in other high risk situations.

The Engineer reviews and approves the proposed pile and soil bearing capacities.

### **5.0 REMOVAL**

Unless otherwise permitted, remove and keep all temporary works upon completion of the work. Do not disturb or otherwise damage the finished work.

Remove temporary works in conformance with the contract documents. Remove them in such a manner as to permit the structure to uniformly and gradually take the stresses due to its own weight.

### **6.0 METHOD OF MEASUREMENT**

Unless otherwise specified, temporary works will not be directly measured.

### **7.0 BASIS OF PAYMENT**

Payment at the contract unit prices for the various pay items requiring temporary works will be full compensation for the above falsework and formwork.

**SUBMITTAL OF WORKING DRAWINGS****(2-14-22)****1.0 GENERAL**

Submit working drawings in accordance with Article 105-2 of the *Standard Specifications* and this provision. For this provision, “submittals” refers to only those listed in this provision. The list of submittals contained herein does not represent a list of required submittals for the project. Submittals are only necessary for those items as required by the contract. Make submittals that are not specifically noted in this provision directly to the Engineer. Either the Structures Management Unit or the Geotechnical Engineering Unit or both units will jointly review submittals.

If a submittal contains variations from plan details or specifications or significantly affects project cost, field construction or operations, discuss the submittal with and submit all copies to the Engineer. State the reason for the proposed variation in the submittal. To minimize review time, make sure all submittals are complete when initially submitted. Provide a contact name and information with each submittal. Direct any questions regarding submittal requirements to the Engineer, Structures Management Unit contacts or the Geotechnical Engineering Unit contacts noted below.

To facilitate in-plant inspection by NCDOT and approval of working drawings, provide the name, address and telephone number of the facility where fabrication will actually be done if different than shown on the title block of the submitted working drawings. This includes, but is not limited to, precast concrete items, prestressed concrete items and fabricated steel or aluminum items.

**2.0 ADDRESSES AND CONTACTS**

For submittals to the Structures Management Unit, use the following addresses:

Via Email: [SMU-wdr@ncdot.gov](mailto:SMU-wdr@ncdot.gov) (do not cc SMU Working Drawings staff)

Via US mail:  
Mr. B. C. Hanks, P. E.  
State Structures Engineer  
North Carolina Department  
of Transportation  
Structures Management Unit  
1581 Mail Service Center  
Raleigh, NC 27699-1581

Attention: Mr. J. L. Bolden, P. E.

Via other delivery service:  
Mr. B. C. Hanks, P. E.  
State Structures Engineer  
North Carolina Department  
of Transportation  
Structures Management Unit  
1000 Birch Ridge Drive  
Raleigh, NC 27610

Attention: Mr. J. L. Bolden, P. E.

For submittals to the Geotechnical Engineering Unit, use the following addresses:

For projects in Divisions 1-7, use the following Eastern Regional Office addresses:



Via Email: [EastGeotechnicalSubmittal@ncdot.gov](mailto:EastGeotechnicalSubmittal@ncdot.gov)

Via US mail:

Mr. David Hering, L.G., P. E.  
Assistant State Geotechnical  
Engineer – Eastern Region  
North Carolina Department  
of Transportation  
Geotechnical Engineering Unit  
Eastern Regional Office  
1570 Mail Service Center  
Raleigh, NC 27699-1570

Via other delivery service:

Mr. David Hering, L.G., P. E.  
Assistant State Geotechnical  
Engineer – Eastern Region  
North Carolina Department  
of Transportation  
Geotechnical Engineering Unit  
Eastern Regional Office  
3301 Jones Sausage Road, Suite 100  
Garner, NC 27529

For projects in Divisions 8-14, use the following Western Regional Office addresses:

Via Email: [WestGeotechnicalSubmittal@ncdot.gov](mailto:WestGeotechnicalSubmittal@ncdot.gov)

Via US mail or other delivery service:

Mr. Eric Williams, P. E.  
Assistant State Geotechnical  
Engineer – Western Region  
North Carolina Department  
of Transportation  
Geotechnical Engineering Unit  
Western Regional Office  
5253 Z Max Boulevard  
Harrisburg, NC 28075

The status of the review of structure-related submittals sent to the Structures Management Unit can be viewed from the Unit's website, via the "[Drawing Submittal Status](#)" link.

The status of the review of geotechnical-related submittals sent to the Geotechnical Engineering Unit can be viewed from the Unit's website, via the "[Geotechnical Construction Submittals](#)" link.

Direct any questions concerning submittal review status, review comments or drawing markups to the following contacts:

Primary Structures Contact:	James Bolden (919) 707 – 6408 <a href="mailto:jlbolden@ncdot.gov">jlbolden@ncdot.gov</a>
Secondary Structures Contacts:	Emmanuel Omile (919) 707 – 6451 <a href="mailto:eomile@ncdot.gov">eomile@ncdot.gov</a> Madonna Rorie (919) 707 – 6508 <a href="mailto:mrorie@ncdot.gov">mrorie@ncdot.gov</a>
Eastern Regional Geotechnical Contact (Divisions 1-7):	David Hering (919) 662 – 4710

[dthering@ncdot.gov](mailto:dthering@ncdot.gov)

Western Regional Geotechnical Contact (Divisions 8-14):

Eric Williams (704) 455 – 8902

[ewilliams3@ncdot.gov](mailto:ewilliams3@ncdot.gov)

### 3.0 SUBMITTAL COPIES

Furnish one complete copy of each submittal, including all attachments, to the Engineer. At the same time, submit a copy of the same complete submittal directly to the Structures Management Unit and/or the Geotechnical Engineering Unit as specified in the tables below.

The first table below covers “Structure Submittals.” The Engineer will receive review comments and drawing markups for these submittals from the Structures Management Unit. The second table in this section covers “Geotechnical Submittals.” The Engineer will receive review comments and drawing markups for these submittals from the Geotechnical Engineering Unit.

Unless otherwise required, submit one set of supporting calculations to either the Structures Management Unit or the Geotechnical Engineering Unit unless both units require submittal copies in which case submit a set of supporting calculations to each unit. Provide additional copies of any submittal as directed.

#### STRUCTURE SUBMITTALS

<b>Submittal</b>	<b>Submittal Required by Structures Management Unit?</b>	<b>Submittal Required by Geotechnical Engineering Unit?</b>	<b>Contract Reference Requiring Submittal <sup>1</sup></b>
Arch Culvert Falsework	Y	N	Plan Note, SN Sheet & “Falsework and Formwork”
Box Culvert Falsework <sup>7</sup>	Y	N	Plan Note, SN Sheet & “Falsework and Formwork”
Cofferdams	Y	Y	Article 410-4
Foam Joint Seals <sup>6</sup>	Y	N	“Foam Joint Seals”
Expansion Joint Seals (hold down plate type with base angle)	Y	N	“Expansion Joint Seals”
Expansion Joint Seals (modular)	Y	N	“Modular Expansion Joint Seals”

Expansion Joint Seals (strip seals)	Y	N	“Strip Seal Expansion Joints”
Falsework & Forms <sup>2</sup> (substructure)	Y	N	Article 420-3 & “Falsework and Formwork”
Falsework & Forms (superstructure)	Y	N	Article 420-3 & “Falsework and Formwork”
Girder Erection over Railroad	Y	N	Railroad Provisions
Maintenance and Protection of Traffic Beneath Proposed Structure	Y	N	“Maintenance and Protection of Traffic Beneath Proposed Structure at Station ____”
Metal Bridge Railing	Y	N	Plan Note
Metal Stay-in-Place Forms	Y	N	Article 420-3
Metalwork for Elastomeric Bearings <sup>4,5</sup>	Y	N	Article 1072-8
Miscellaneous Metalwork <sup>4,5</sup>	Y	N	Article 1072-8
Disc Bearings <sup>4</sup>	Y	N	“Disc Bearings”
Overhead and Digital Message Signs (DMS) (metalwork and foundations)	Y	N	Applicable Provisions
Placement of Equipment on Structures (cranes, etc.)	Y	N	Article 420-20
Prestressed Concrete Box Beam (detensioning sequences) <sup>3</sup>	Y	N	Article 1078-11
Precast Concrete Box Culverts	Y	N	“Optional Precast Reinforced Concrete Box Culvert at Station ____”
Prestressed Concrete Cored Slab (detensioning sequences) <sup>3</sup>	Y	N	Article 1078-11
Prestressed Concrete Deck Panels	Y	N	Article 420-3
Prestressed Concrete Girder (strand elongation and detensioning sequences)	Y	N	Articles 1078-8 and 1078- 11
Removal of Existing Structure over Railroad	Y	N	Railroad Provisions
<hr/>			
Revised Bridge Deck Plans (adaptation to prestressed deck panels)	Y	N	Article 420-3

Revised Bridge Deck Plans (adaptation to modular expansion joint seals)	Y	N	“Modular Expansion Joint Seals”
Sound Barrier Wall (precast items)	Y	N	Article 1077-2 & “Sound Barrier Wall”
Sound Barrier Wall Steel Fabrication Plans <sup>5</sup>	Y	N	Article 1072-8 & “Sound Barrier Wall”
Structural Steel <sup>4</sup>	Y	N	Article 1072-8
Temporary Detour Structures	Y	Y	Article 400-3 & “Construction, Maintenance and Removal of Temporary Structure at Station _____”
TFE Expansion Bearings <sup>4</sup>	Y	N	Article 1072-8

**FOOTNOTES**

- References are provided to help locate the part of the contract where the submittals are required. References in quotes refer to the provision by that name. Articles refer to the *Standard Specifications*.
- Submittals for these items are necessary only when required by a note on plans.
- Submittals for these items may not be required. A list of pre-approved sequences is available from the producer or the Materials & Tests Unit.
- The fabricator may submit these items directly to the Structures Management Unit.
- The two sets of preliminary submittals required by Article 1072-8 of the *Standard Specifications* are not required for these items.
- Submittals for Fabrication Drawings are not required. Submittals for Catalogue Cuts of Proposed Material are required. See Section 5.A of the referenced provision.
- Submittals are necessary only when the top slab thickness is 18” or greater.

**GEOTECHNICAL SUBMITTALS**

<b>Submittal</b>	<b>Submittals Required by Geotechnical Engineering Unit</b>	<b>Submittals Required by Structures Management Unit</b>	<b>Contract Reference Requiring Submittal <sup>1</sup></b>
Drilled Pier Construction Plans <sup>2</sup>	Y	N	Subarticle 411-3(A)
Crosshole Sonic Logging (CSL) Reports <sup>2</sup>	Y	N	Subarticle 411-5(A)(2)
Pile Driving Equipment Data Forms <sup>2,3</sup>	Y	N	Subarticle 450-3(D)(2)
Pile Driving Analyzer (PDA) Reports <sup>2</sup>	Y	N	Subarticle 450-3(F)(3)
Retaining Walls <sup>4</sup>	Y; drawings and calculations	Y; drawings	Applicable Provisions
Temporary Shoring <sup>4</sup>	Y; drawings and calculations	Y; drawings	“Temporary Shoring” & “Temporary Soil Nail Walls”

**FOOTNOTES**

- References are provided to help locate the part of the contract where the submittals are required. References in quotes refer to the provision by that name. Subarticles refer to the *Standard Specifications*.
- Submit one hard copy of submittal to the Engineer. Submit a second copy of submittal electronically (PDF via email), US mail or other delivery service to the appropriate Geotechnical Engineering Unit regional office. Electronic submission is preferred.
- The Pile Driving Equipment Data Form is available from:  
[https://connect.ncdot.gov/resources/Geological/Pages/Geotech\\_Forms\\_Details.aspx](https://connect.ncdot.gov/resources/Geological/Pages/Geotech_Forms_Details.aspx)  
See second page of form for submittal instructions.
- Electronic copy of submittal is required. See referenced provision.

**CRANE SAFETY****(6-20-19)**

Comply with the manufacturer specifications and limitations applicable to the operation of any and all cranes and derricks. Prime contractors, sub-contractors, and fully operated rental companies shall comply with the current Occupational Safety and Health Administration (OSHA) regulations.

Submit all items listed below to the Engineer prior to beginning crane operations. Changes in personnel or equipment must be reported to the Engineer and all applicable items listed below must be updated and submitted prior to continuing with crane operations.

**CRANE SAFETY SUBMITTAL LIST**

- A. **Competent Person:** Provide the name and qualifications of the “Competent Person” responsible for crane safety and lifting operations. The named competent person will have the responsibility and authority to stop any work activity due to safety concerns.
- B. **Riggers:** Provide the qualifications and experience of the persons responsible for rigging operations. Qualifications and experience should include, but not be limited to, weight calculations, center of gravity determinations, selection and inspection of sling and rigging equipment, and safe rigging practices.
- C. **Crane Inspections:** Inspection records for all cranes shall be current and readily accessible for review upon request.
- D. **Certifications:** Crane operators shall be certified by the National Commission for the Certification of Crane Operators (NCCCO) or the National Center for Construction Education and Research (NCCER). Other approved nationally accredited programs will be considered upon request. In addition, crane operators shall have a current CDL medical card. Submit a list of crane operator(s) and include current certification for each type of crane operated (small hydraulic, large hydraulic, small lattice, large lattice) and medical evaluations for each operator.

**GROUT FOR STRUCTURES****(12-1-17)****1.0 DESCRIPTION**

This special provision addresses grout for use in pile blockouts, grout pockets, shear keys, dowel holes and recesses for structures. This provision does not apply to grout placed in post-tensioning ducts for bridge beams, girders, decks, end bent caps, or bent caps. Mix and place grout in accordance with the manufacturer’s recommendations, the applicable sections of the Standard Specifications and this provision.

**2.0 MATERIAL REQUIREMENTS**

Unless otherwise noted on the plans, use a Type 3 Grout in accordance with Section 1003 of the Standard Specifications.

Initial setting time shall not be less than 10 minutes when tested in accordance with ASTM C266.

Construction loading and traffic loading shall not be allowed until the 3 day compressive strength is achieved.

### 3.0 SAMPLING AND PLACEMENT

Place and maintain components in final position until grout placement is complete and accepted. Concrete surfaces to receive grout shall be free of defective concrete, laitance, oil, grease and other foreign matter. Saturate concrete surfaces with clean water and remove excess water prior to placing grout.

### 4.0 BASIS OF PAYMENT

No separate payment will be made for "Grout for Structures". The cost of the material, equipment, labor, placement, and any incidentals necessary to complete the work shall be considered incidental to the structure item requiring grout.

## SHOTCRETE REPAIRS

(08-08-22)

### GENERAL

The work covered by this special provision consists of removing deteriorated concrete from the structure in accordance with the limits, depth and details shown on the plans, described herein and as established by the Engineer. This work also includes removing and disposing all loose debris, cleaning and repairing reinforcing steel and applying structural shotcrete.

The location and extent of repairs shown on the plans are general in nature. The Engineer shall determine the extent of removal in the field based on an evaluation of the condition of the exposed surfaces.

Any portion of the structure that is damaged from construction operations shall be repaired to the Engineer's satisfaction, at no extra cost to the Department.

### MATERIAL REQUIREMENTS

Use prepackaged dry mix shotcrete conforming to the requirements of ASTM C1480, the applicable sections of the *Standard Specifications* and the following:

Test Description	Test Method	Age (Days)	Specified Requirements
Silica Fume (%)	ASTM C1240	-	10 (Max.)
Air Content - As Shot (%)	ASTM C231 or ASTM C457	-	5 ± 2

Minimum Compressive Strength (psi)	ASTM C109	7	3,000
		28	5,000
Minimum Bond Pull-off Strength (psi)	ASTM C1583 or ASTM C882	28	250
Rapid Chloride Permeability Tests (range in coulombs)	ASTM C1202	-	100 - 1000

Admixtures are not allowed unless approved by the Engineer. Store shotcrete in an environment where temperatures remain above 40°F and less than 95°F

All equipment must operate in accordance with the manufacturer's specifications and material must be placed within the recommended time.

### QUALITY CONTROL

#### (A) Qualification of Shotcrete Contractor

The shotcrete Contractor shall provide proof of experience by submitting a description of jobs similar in size and character that have been completed within the last five (5) years. The name, address and telephone number of references for the submitted projects shall also be furnished. Failure to provide appropriate documentation will result in the rejection of the proposed shotcrete contractor.

#### (B) Qualification of Nozzleman

The shotcrete Contractor's nozzleman shall be certified by the American Concrete Institute (ACI). Submit proof of certification to the Engineer prior to beginning repair work. The nozzleman shall maintain certification at all times while work is being performed for the Department. Failure to provide and maintain certification will result in the rejection of the proposed nozzleman.

### TEMPORARY WORK PLATFORM

Prior to beginning any repair work, provide details for a sufficiently sized temporary work platform at each repair location. Design steel members to meet the requirements of the American Institute of Steel Construction Manual. Design timber members in accordance with the *National Design Specification for Stress-Grade Lumber and Its Fastenings* of the National Forest Products Association. Submit the platform design and plans for review and approval. The design and plans shall be sealed and signed by a North Carolina registered Professional Engineer. Do not install the platform until the design and plans are approved. Drilling holes in the superstructure for the purpose of attaching the platform is prohibited. Upon completion of work, remove all anchorages in the substructure and repair the substructure at no additional cost to the Department.

### SURFACE PREPARATION



Prior to starting the repair operation, delineate all surfaces and areas assumed to be deteriorated by visually examining and sounding the concrete surface with a hammer or other approved method. The Engineer is the sole judge in determining the limits of deterioration.

Prior to removal, introduce a shallow saw cut approximately ½" in depth around the repair area at right angles to the concrete surface. Remove all deteriorated concrete 1 inch below the reinforcing steel with a 17 lb (maximum) pneumatic hammer with points that do not exceed the width of the shank or with hand picks or chisels as directed by the Engineer. Do not cut or remove the existing reinforcing steel. Unless specifically directed by the Engineer, do not remove concrete deeper than 1 inch below the reinforcing steel.

Abrasive blast all exposed concrete surfaces and existing reinforcing steel in repair areas to remove all debris, loose concrete, loose mortar, rust, scale, etc. After sandblasting examine the reinforcing steel to ensure at least 90% of the original diameter remains. If there is more than 10% reduction in the rebar diameter, splice in and securely tie supplemental reinforcing bars as directed by the Engineer.

Provide stainless welded wire fabric at each repair area larger than one square foot if the depth of the repair exceeds 2 inches from the existing, intact exterior face of the concrete member. Provide a minimum 4" x 4" - 12 gage stainless welded wire fabric unless otherwise shown on the plans. Rigidly secure the welded wire fabric to existing steel or to 3/16" diameter stainless hook fasteners adequately spaced to prevent sagging. Encase the welded wire fabric in shotcrete a minimum depth of 1½ inches.

With the exception of overhead applications, the contractor has the option to use synthetic fiber reinforcement as an alternate to welded wire fabric if attaching welded wire fabric is impractical or if approved by the Engineer. Welded wire fabric and synthetic fiber reinforcement shall not be used in the same repair area.

Thoroughly clean the repair area of all dirt, grease, oil or foreign matter, and remove all loose or weakened material before applying shotcrete. Saturate the repair area with clean water the day before applying shotcrete. Bring the wetted surface to a saturated surface dry (SSD) condition prior to applying shotcrete and maintain this condition until the application begins. Use a blowpipe to facilitate removal of free surface water. Only oil-free compressed air is to be used in the blowpipe.

The time between removal of deteriorated concrete and applying shotcrete shall not exceed five (5) calendar days. If the time allowance exceeds (5) calendar days, prepare the surface at the direction of the Engineer before applying shotcrete.

#### **APPLICATION AND SURFACE FINISH**

Apply shotcrete only when the surface temperature of the repair area is greater than 40°F and less than 95°F. Do not apply shotcrete to frosted surfaces. Maintain shotcrete at a minimum temperature of 40°F for three (3) calendar days after placement.

Apply shotcrete in layers. The properties of the applied shotcrete determine the proper thickness of each layer or lift.

The nozzleman should hold the nozzle three (3) to four (4) feet from the surface being covered in a position that ensures the shotcrete strikes at right angles to the surface being covered without excessive impact. The nozzleman shall maintain the water amount at a practicable minimum, so the mix properly adheres to the repair area. Water content should not become high enough to cause the mix to sag or fall from vertical or inclined surfaces, or to separate in horizontal layers.

Use shooting wires or guide strips that do not entrap rebound sand. Use guide wires to provide a positive means of checking the total thickness of the shotcrete applied. Remove the guide wires prior to the final finish coat.

To avoid leaving sand pockets in the shotcrete, blow or rake off sand that rebounds and does not fall clear of the work, or which collects in pockets in the work. Do not reuse rebound material in the work.

If a work stoppage longer than two (2) hours takes place on any shotcrete layer prior to the time it has been built up to required thickness, saturate the area with clean water and use a blowpipe as outlined previously, prior to continuing with the remaining shotcrete course. Do not apply shotcrete to a dry surface.

Finish all repaired areas, including chamfered edges, as close as practicable to their original dimensions and configuration, unless otherwise required to provide a minimum 2" of cover for reinforcing steel exposed during repair. If necessary to extend shotcrete repair material beyond the original member dimensions and geometry, coordinate with the Engineer to determine methods, geometry, and dimensions of the final finished surface to provide a minimum 2" of cover on reinforcing steel. Slightly build up and trim shotcrete to the final surface by cutting with the leading edge of a sharp trowel. Use a rubber float to correct any imperfections. Limit work on the finished surface to correcting imperfections caused by trowel cutting.

Immediately after bringing shotcrete surfaces to final thickness, thoroughly check for sags, bridging, and other deficiencies. Repair any imperfections at the direction of the Engineer.

Cure the completed shotcrete surface in accordance with Article 420-15(B) Water Method, of the *Standard Specifications* for seven (7) calendar days. If the water method is impracticable and if approved by the Engineer, a membrane curing compound may be used in accordance with Subarticle 420-15(C) at double the manufacturer's recommended coverage rate.

#### **MATERIAL TESTING & ACCEPTANCE**

Each day shotcreting takes place, the nozzleman shall shoot one 18" x 18" x 3.5" test panel in the same position as the repair work that is being done to demonstrate the shotcrete is being applied

properly. Store, handle and cure the test panel in the same manner as the repaired substructure and do not disturb for the first 24 hours after shotcreting.

Approximately 72 hours after completing the final shotcrete placement, thoroughly test the surface with a hammer. At this time, the repair area should have sufficient strength for all sound sections to ring sharply. Remove and replace any unsound portions prior to the final inspection of the work. No additional compensation will be provided for removal and replacement of unsound shotcrete.

In accordance with Subarticle 1002-3(H) of the Standard Specifications, core three (3) 3" diameter samples from each test panel. Compressive strength values on test panels shall equal or exceed the required 28-day strength requirements. Should failures occur on the test panel cores, acceptance of the material will be determined by tests on cores from the installed work on the structure. A minimum of (3) three cores shall be taken from the area in question of the structure. The average compressive strength of the cores taken from the structure shall equal or exceed the specified strength of the shotcrete applied, and no single core shall have strength less than 85% of the specified value. Any cores taken from the structure shall penetrate into the existing concrete at least two (2) inches. Cores shall also be inspected for delamination, sand pockets, segregation, and voids.

The adequacy of the bond between the existing concrete and the shotcrete shall be determined by direct tension bond testing, in accordance with ASTM C1583 or ASTM C882, as directed by the Engineer. A minimum bond strength of 250 psi will be accepted as satisfactory. Bond failure less than 250 psi attributable to the failure of existing concrete will not be cause for rejection. The cost of up to three passing direct tension bond tests shall be the responsibility of the Contractor; additional passing pull-off tests will be the responsibility of the Department.

Any repair work failing to meet the requirements of this provision will be rejected and the Contractor shall implement a remediation plan to correct the deficiency at no additional cost to the Department. No extra payment will be provided for drilling extra cores. Patch all core holes in the repaired structure to the satisfaction of the Engineer.

#### **MEASUREMENT AND PAYMENT**

*Shotcrete Repairs* will be measured and paid for at the contract unit price bid per cubic foot and will be full compensation for removal, containment and disposal off-site of unsound concrete including the cost of materials, labor, tools, equipment and incidentals necessary to complete the repair work. Depth will be measured from the original outside concrete face. If modifications to the dimensions and geometry are approved by the Engineer to achieve proper clearance over reinforcing steel, depth measurements will be made from the modified final outside face. The Contractor and Engineer will measure quantities after removal of unsound concrete and before application of repair material. Payment will also include the cost of sandblasting, surface cleaning and preparation, cleaning of reinforcing steel, placement of new steel, cost of temporary work platform, testing for soundness and bond strength, curing of shotcrete and taking core samples from the test panels and the structure.

Payment will be made under:

<b>Pay Item</b>	<b>Pay Unit</b>
Shotcrete Repairs	Cubic Feet

**CONCRETE REPAIRS****(2-11-19)****DESCRIPTION**

Work includes removal of concrete in spalled, delaminated and/or cracked areas of the existing bent caps, bent columns, underside of bridge decks, deck slabs, girders, and bridge rails in reasonably close conformity with the lines, depth, and details shown on the plans, described herein and as established by the Engineer. This work also includes straightening, cleaning, and replacement of reinforcing steel, doweling new reinforcing steel, removing all loose materials, removing and disposing of debris, formwork, applying repair material, and protecting adjacent areas of the bridge and environment from material leakage. The repair material shall be one of the materials described in this Special Provision, unless otherwise noted in the plans or special provisions.

The location and extent of repairs shown on the plans described herein are general in nature. The Engineer shall determine the extent of removal in the field based on an evaluation of the condition of the exposed surfaces. The Contractor shall coordinate removal operations with the Engineer. No more than 30% of a round or square column or 30% of the bearing area under a beam shall be removed without a temporary support system and approval from the Engineer.

Repair, to the Engineer's satisfaction, any portion of the structure that is damaged from construction operations. No extra payment is provided for these repairs.

**SURFACE PREPARATION**

Adhere to the following surface preparation requirements or the repair material manufacturer's requirements, whichever is more stringent.

Prior to starting the repair operation, delineate all surfaces and areas assumed to be deteriorated by visually examining and sounding the concrete surface with a hammer or other approved method. The Engineer is the sole judge in determining the limits of deterioration.

Prior to concrete removal, introduce a shallow saw cut, 1/2" in depth, around the repair area at right angles to the concrete surface. Sawcut should be located a minimum 2" beyond the perimeter of the deteriorated concrete area to be repaired. Remove all concrete within the sawcut to a minimum depth of 1/2". If concrete removal exposes reinforcing steel, remove all deteriorated concrete 1" below the reinforcing steel with a 17 lb (maximum) pneumatic hammer, with points that do not exceed the width of the shank, or with hand picks or chisels, as directed by the Engineer. Do not cut or remove the existing reinforcing steel. Unless specifically directed by the Engineer, do not remove concrete deeper than 1" below the reinforcing steel.

Abrasive blast all exposed concrete surfaces and existing reinforcing steel in repair areas to remove all debris, loose concrete, loose mortar, rust, scale, etc. After blasting, examine the reinforcing steel to ensure at least 90% of the original diameter remains. If there is more than 10% reduction in the rebar diameter, splice in and securely tie supplemental reinforcing bars as directed by the Engineer. This might require additional removal of concrete, in order to achieve an appropriate splice length of the reinforcing steel.

Thoroughly clean the repair area of all dirt, grease, oil, or foreign matter, and remove all loose or weakened material by abrasive blasting before applying concrete repair material. Acid etch with 15% hydrochloric acid, only if approved by the Engineer. Follow acid etching by scrubbing and flushing with copious amounts of clean water. Check the cleaning using moist pH paper. Water cleaning is complete when the paper reads ten (10) or higher.

Follow all abrasive blasting with vacuum cleaning.

The time between removal of deteriorated concrete and applying concrete repair material shall not exceed 72 hours. If the time allowance exceeds 72 hours, prepare the surface at the direction of the Engineer before applying concrete repair material.

#### **APPLICATION AND SURFACE FINISH**

Apply repair material to damp surfaces only when allowed by repair material recommendations and approved by the Engineer. Prepare damp surfaces in accordance with the *Standard Specifications* and/or repair material manufacturer's recommendations. Use a blowpipe to facilitate removal of free surface water. Only oil-free compressed air is to be used in the blowpipe.

When surface preparation is completed, mix and apply repair material in accordance with the *Standard Specifications* and/or repair material manufacturer's recommendations.

Use aggregate that is washed, kiln-dried, and bagged. Maximum size of aggregate shall not exceed 2/3 of the minimum depth of the repair area, or 3/4 of the depth of excavation behind the reinforcing steel, whichever is smaller.

Unless otherwise required by the repair material manufacturer, apply bonding agent to all repair areas immediately prior to placing repair material.

Repair areas shall be formed unless otherwise approved by the Engineer. Form and finish all repaired areas, including chamfered edges, as close as practicable to their original "As Built" dimensions and configuration. After applying the repair material, remove excessive material and provide a smooth, flush surface, unless directed otherwise.

Cure finished Class A concrete repair material by maintaining 95% relative humidity at the repair and surrounding areas by fogging, moist curing, or other approved means for seven (7) days. Cure polymer modified concrete repair material in accordance with manufacturer's recommendations.

#### **REPAIR MATERIAL OPTIONS**

##### **(A) Polymer Modified Concrete Repair Material**

Repair material shall be polymer modified cement mortar for vertical or overhead applications and shall be suitable for applications in marine environments. Material shall be approved for use by NCDOT. Submit repair material to the Engineer for review and approval prior to beginning the work. Color of repair material shall be concrete gray.

##### **(B) Class A Concrete Repair Material**

Repair material shall be Class A Portland Cement Concrete as described in Article 1000-4 of the *Standard Specifications*.

#### **TEMPORARY WORK PLATFORM**

Prior to beginning any repair work, provide details for a sufficiently sized temporary work platform at each repair location. Design steel members to meet the requirements of the *American Institute of*

*Steel Construction Manual*. Design timber members in accordance with the *National Design Specification for Stress-Grade Lumber and Its Fastenings* of the National Forest Products Association. Submit the platform design and plans for review and approval. The design and plans shall be sealed and signed by a North Carolina registered Professional Engineer. Do not install the platform until the design and plans are approved. Drilling holes in the superstructure for the purpose of attaching the platform is prohibited. Upon completion of work, remove all anchorages in the substructure and repair the substructure at no additional cost to the Department.

#### **MEASUREMENT AND PAYMENT**

*Concrete Repairs* will be measured and paid for at the contract unit price bid per cubic foot and will be full compensation for removal, containment and disposal off-site of unsound concrete including the cost of materials, reinforcing steel, labor, tools, equipment and incidentals necessary to complete the repair work. Depth will be measured from the original outside concrete face. The Contractor and Engineer will measure quantities after removal of unsound concrete and before application of repair material. Payment will also include the cost of abrasive blasting, surface cleaning and preparation, blast cleaning of reinforcing steel, placement of new reinforcing steel, cost of temporary work platform, testing of the soundness of the exposed concrete surface, furnishing and installation of repair mortar material, curing and sampling of concrete, and protection/cleaning of adjacent areas from splatter or leakage.

Reinforcing Steel that is required for the repairs will be in accordance with Section 425 of the *Standard Specifications*.

Payment will be made under:

<b>Pay Item</b>	<b>Pay Unit</b>
Concrete Repairs	Cubic Feet

**PAINTING EXISTING WEATHERING STEEL STRUCTURE****(2-11-19)****DESCRIPTION**

This work shall consist of furnishing all labor, equipment, and materials necessary to clean and paint the ends of the weathering steel girders, zones of excessive corrosion, bent diaphragms, all bearing plates, anchor bolts, nuts, and washers of the existing structure. Work includes: removal, containment and disposal of the existing paint system; preparation of the surface to be painted and applying the new paint system; a containment enclosure; and any incidentals necessary to complete the project as specified and shown on the plans.

**DESCRIPTION OF BRIDGES**

**Bridge #1039:** This bridge was built in 2003 and carries SR 2517 (Rogers Lane) over I-87/US-64/US-264, Crabtree Creek and NS Railroad. The superstructure consists of 3 continuous spans with 7 lines of steel plate girders @ 9'-8" spacing with steel cross frames. The continuous span consists of steel plate girders with a 90" web depth and 22" top flange width and 15" to 23" bottom flange width. The bridge has an overall length of 590'-6 5/8" with a concrete deck and a 64'-7 1/2" total deck width. The existing paint system is weathering steel, and the estimated area to be cleaned and painted is **4,850** sq. ft.

**Bridge #1083:** This bridge was built in 2007 and carries NC-98 over US-1 (Capital Blvd). The superstructure consists of 2 spans with up to 22 lines of steel plate girders varying spacing with steel cross frames. The spans consists of steel plate girders with a 63 1/4" web depth and 14" top flange width and 14" bottom flange width. The bridge has an overall length of 157'-5 3/16" with a concrete deck that varies to a maximum deck width of 228'-10 11/16". The existing paint system is weathering steel, and the estimated area to be cleaned and painted is **27,263** sq. ft.

**TWELVE-MONTH OBSERVATION PERIOD**

The Contractor maintains responsibility for the coating system for a 12-month observation period beginning upon the satisfactory completion of all the work required in the plans or as directed by the Engineer. The Contractor shall guarantee the coating system under the payment and performance bond (refer to Article 109-10 of the *Standard Specifications*). To complete successfully the observation period, the coating system shall meet the following requirements after 12 months service:

- (A) No visible rust, contamination or application defect is observed in any coated area.
- (B) Painted surfaces have a uniform color and gloss.
- (C) Painted surfaces have an adhesion that meets an ASTM D3359, 3A rating.

Final acceptance is made only after the paint system meets the above requirements.

**SUBMITTALS**

Submit all of the following to the Engineer for review and approval before scheduling the pre-construction meeting. Allow at least two (2) weeks for the review process.

- (A) The existing paint systems include toxic substances such as red lead oxide, which are considered hazardous if improperly removed. The contractor shall be currently Society for Protective Coatings (SSPC) Quality Program (QP) 2, Category A certified, and have successfully completed lead paint removal and field painting on similar structures within 18 months prior to this bid. Lead abatement work completed within the 18 month period shall have been completed in accordance with contract specifications, free of citation from safety or environmental agencies. Lead abatement work shall include, but not be limited to: abrasive blasting; waste handling, storage and disposal; worker safety during lead abatement activities (fall protection, personal protective equipment (PPE), etc.); and containment. This requirement is in addition to the contractor pre-qualification requirements covered by Article 102-2 of the *Standard Specifications*.

The apparent low bidder shall submit a list of projects for which QP 2 work was performed within the last 18 months including owner contact information and submit to the Engineer a "Lead Abatement Affidavit". This form may be downloaded from: <https://www.ncdot.gov/initiatives-policies/Transportation/bridges/Documents/leadabatementaffidavit.pdf>

- (B) Work schedule which shall be kept up to date, with a copy of the revised schedule being provided to the Engineer in a timely manner.
- (C) Containment system plans and design calculations in accordance with SSPC Guide 6, Class 3A and other project requirements, signed and sealed by a Professional Engineer licensed by the State of North Carolina.
- (D) Bridge wash water sampling and disposal plan.
- (E) Subcontractor identification.
- (F) Lighting plan for night work in accordance with Section 1413 of the *Standard Specifications*.
- (G) Traffic control plan with NCDOT certified supervisors, flaggers and traffic control devices.
- (H) Health and safety plan addressing at least the required topics as specified by the SSPC QP 1 and QP 2 program and including hazard communication, respiratory health, emergency procedures, and local hospital and treatment facilities with directions and phone numbers, disciplinary criteria for workers who violate the plan and accident investigation. The plan shall address the following: hazardous materials, personal protective equipment, general health and safety, occupational health and environmental controls, fire protection and prevention, signs signals, and barricades, materials handling, storage, use, and disposal, hand and power tools, welding and cutting, electrical, scaffolds, fall protection, cranes, derricks, hoists, elevators, and conveyors, ladders, toxic and hazardous substances, airless injection and high pressure water jet (HPWJ).
- (I) Provide the Engineer a letter of certification that all employees performing work on the project have blood lead levels that are below the Occupational Safety and Health Administration (OSHA) action level.
- (J) Provide the Engineer with Competent Person qualifications and summary of work experience.
- (K) Environmental Compliance Plan.
- (L) Quality Control Plan (Project Specific) with quality control qualifications and summary of work experience.
- (M) Bridge and Public Protection Plan (Overspray, Utilities, etc. - Project/Task Specific).



(N) Abrasive Blast Media:

- (1) Product Data Sheet.
- (2) Blast Media Test Reports in accordance with Article 1080-12 of the *Standard Specification*.

(O) Coating Material:

- (1) NCDOT HICAMS Test Reports (testing performed by NCDOT Materials and Tests Unit).
- (2) Product Data Sheets.
- (3) Material Safety Data Sheets.
- (4) Product Specific Repair Procedures.
- (5) Acceptance letters from paint manufacturer's for work practices that conflict with special provisions and/or paint manufactures product data sheets.

### **PRE-CONSTRUCTION MEETING**

Submittals shall be reviewed and approved by the Engineer prior to scheduling the pre-construction meeting. Allow no less than two (2) weeks for a review process. When requesting a pre-construction meeting, contact the Engineer at least seven (7) working days in advance of the desired pre-construction date. The contractor's project supervisor, Competent Person, quality control personnel and certified traffic control supervisor shall be in attendance at the pre-construction meeting in order for the Contractor and NCDOT team to establish responsibilities for various personnel during project duration and to establish realistic timeframes for problem escalation.

### **CONTAINMENT SYSTEM**

Prior to performing any construction or painting operations on the structure, the Contractor shall furnish the Engineer with plans and design calculations for a sufficiently designed containment system, which will provide access for any repairs on structural steel members, cleaning and surface preparations for structural steel members, and coating operations for structural steel members of the bridge. The containment system shall not be installed, and no work shall begin, until the Engineer has reviewed and approved, in writing, the submitted containment system plans and design calculations. Containment system plans and design calculations shall be prepared, sealed, and signed by a Professional Engineer licensed by the State of North Carolina. Allow a minimum of two (2) weeks for review of the containment plans and calculations.

The containment system shall meet or exceed the requirements of Class 3A containment in accordance with SSPC Guide 6. The Contractor shall determine the required capacity of the containment system, which, at a minimum, shall include loads due to wind, repair materials and repair operations, equipment, and tools; however, the capacity shall not be less than that required by Federal or State regulations. Design steel members to meet the requirements of the *American Institute of Steel Construction Manual*. Design timber members in accordance with the *National Design Specification for Stress-Grade Lumber and Its Fastenings* of the National Forest Products Association. The containment system shall be constructed of materials capable of withstanding damage from any of the work required on this project and shall provide a two (2) hour resistance to fire.

In the containment system plans, describe how debris is contained and collected. Describe the type of tarpaulin, bracing materials, and the maximum designed wind load. Design wind loads shall be in accordance with the Falsework and Formwork special provision. Describe the dust collection system and how a negative pressure of 0.03 inches of water column is maintained inside the enclosure, while blasting operations are being conducted. Describe how the airflow inside the containment structure is designed to meet all applicable OSHA Standards. Describe how water run-off from rain will be routed by or through the enclosure. Describe how wash water will be contained and paint chips separated. Describe what physical containment will be provided during painting application to protect the public and areas not to be painted.

Drilling holes in the superstructure for the purpose of attaching the containment system is prohibited.

The Contractor will be responsible for certifying the containment system has been constructed in accordance with the approved plans.

The containment system shall be cleaned after each workday.

Upon completion of work, remove all anchorages in the substructure and repair the substructure at no additional cost to the Department.

Protect non-metallic parts of bearings from blasting and painting (i.e.: Pot Bearings, Elastomeric Pads, and Disc Bearings).

#### **WASH WATER SAMPLING AND DISPOSAL PLAN**

All wash water shall be collected and sampled prior to disposal. Representative sampling and testing methodology shall conform to North Carolina Administrative Code 15A NCAC 02B.0103, "Analytical Procedures". Wash water shall be tested for pollutants listed in 15A NCAC 02B.0211(3), 15A NCAC 02T.0505(b)(1) and 15A NCAC 2T.0905(h). Depending on the test results, wash water disposal methods shall be described in the disposal plan. Wash water shall be disposed of in accordance with all current Federal and State regulations. See link for NCDOT Guidelines for Managing Bridge Wash Water: <https://www.ncdot.gov/initiatives-policies/Transportation/bridges/Documents/WashWater.pdf>

#### **WASTE HANDLING OF PAINT AND ABRASIVES**

Comply with all Federal, State, and local regulations. Failure to comply with the regulations could result in fines and loss of qualified status with NCDOT.

Comply with the Resource Conservation and Recovery Act (RCRA - 40 CFR 261 - 265) and the Occupational Safety and Health Act (OSHA - 29 CFR 1910 - 1926) regulations for employee training, and for the handling, storage, labeling, recordkeeping, reporting, inspections and disposal of all hazardous waste generated during paint removal.

A summary of Generator Requirements is available at the above NCDOT web link, which cites the specific regulations for each Generator category. Quantities of waste by weight and dates of waste generation shall be recorded. Waste stored at the project site shall be properly labeled. All waste, hazardous or non-hazardous, requires numbered shipping manifests.

The North Carolina Department of Environmental Quality (NCDEQ) have adopted RCRA as the North Carolina Hazardous Waste Management Rules and are responsible for enforcement. The *Hazardous Waste Generator Compliance Manual* is published by the Compliance Branch of the Division of Waste Management of NCDEQ, and can be found at: <https://files.nc.gov/ncdeq/Waste%20Management/DWM/HW/Compliance/Generator%20Compliance%20Manual.pdf>

Immediately after award of the contract, arrange for waste containers, sampling, testing, transportation, and disposal of all waste. No work shall begin until the Contractor furnishes the Engineer with a written waste disposal plan. Any alternative method for handling waste shall be pre-approved by the Engineer. Use an approved waste management company from the following link:

<https://www.ebs.nc.gov/VendorDirectory/results.html?sap-params=cD0xJTIwJmN1cnJlbnRfc2VhcmNoX3BhZ2U9d2Mmc2VsZWN0aW9uX2Zpcm1fbmFtZT0mc2VsZWN0aW9uX2NlcnQ9JnNlbnRfc2VhcmNoX3BhZ2U9d2Mmc2VsZWN0aW9uX2Zpcm10eXBIPSzZzWxly3Rpb25fd29ya2xvY2F0aW9uPSZ5c2Nfd29ya2xvY2F0aW9uPSZzZzWxly3Rpb25fYWRkenN0YXRIPSz5c2NfYWRkenN0YXRIPSzZzWxly3Rpb25fYWRkcmNvdW50eT0meXNjX2FkZHZHjb3VudHk9JnNlbnRfc2VhcmNoX3BhZ2U9d2Mmc2VsZWN0aW9uX2Zpcm10eXBIPSzZzWxly3Rpb25fZGlzYz0meXNjX2Rpc2M9JnNlbnRfc2VhcmNoX3BhZ2U9d2Mmc2VsZWN0aW9uX2Zpcm10eXBIPSzZzWxly3Rpb25fY3R5cGU9MA%3d%3d>

All removed paint and spent abrasive media shall be tested for lead following the SW-846 Toxicity Characteristic Leaching Procedure (TCLP) Method 1311 Extraction, as required in 40 CFR 261, Appendix 11, to determine whether it shall be disposed of as hazardous waste. Furnish the Engineer certified test reports showing TCLP results of the paint chips stored on site, with disposal in accordance with “Flowchart on Lead Waste Identification and Disposal” at:

<https://ncdenr.s3.amazonaws.com/s3fs-public/document-library/Lead%20Disposal.pdf>

All sampling shall be done in presence of the Engineer’s representative.

The Competent Person shall obtain composite samples from each barrel of the wash water and waste generated by collecting two or more portions taken at regularly spaced intervals during accumulation. Composite the portions into one sample for testing purposes. Acquire samples after 10% or before 90% of the barrel has accumulated. The intent is to provide samples that are representative of widely separated portions, but not the beginning and end of wash water or waste accumulation.

Perform sampling by passing a receptacle completely through the discharge stream or by completely diverting the discharge into a sample container. If discharge of the wash water or waste is too rapid to divert the complete discharge stream, discharge into a container or transportation unit sufficiently large to accommodate the flow and then accomplish the sampling in the same manner as described above.

Comply with the NCDEQ *Hazardous Waste Compliance Generator Manual*. Record quantities of waste by weight and dates of waste generation. Until test results are received, store all waste, and label as “NCDOT Bridge Paint Removal Waste - Pending Analysis” and include the date generated and contact information for the Engineer. Store waste containers in an enclosed, sealed, and secured storage container protected from traffic from all directions. Obtain approval for the protection plan for these containers from the Engineer. If adequate protection cannot be obtained by use of existing guardrail, provide the necessary supplies and equipment to maintain adequate protection. Once test results are

received and characterized, label waste as either “Hazardous Waste - Pending Disposal” or “Paint Waste - Pending Disposal”.

Once the waste has been collected, and the quantities determined, prepare the appropriate shipping documents and manifests and present them to the Engineer. The Engineer will verify the type and quantity of waste and obtain a Provisional Environmental Protection Agency (EPA) ID number from:

Melodi Deaver  
Division of Waste Management/Hazardous Waste Section  
North Carolina Department of Environmental Quality  
1646 Mail Service Center  
Raleigh, NC 27699  
Phone: (919) 707-8204, Email: [melodi.deaver@ncdenr.gov](mailto:melodi.deaver@ncdenr.gov)

At the time of shipping, the Engineer will sign, date, and add the ID number in the appropriate section on the manifest. The maximum on-site storage time for collected waste shall be 90 calendar days. All waste whether hazardous or non-hazardous will require numbered shipping manifests. The cost for waste disposal (including lab and Provisional EPA ID number) is included in the bid price for this contract. Note NC Hazardous Waste Management Rules (15A NCAC 13A) for more information. Provisional EPA ID numbers may be obtained at:

<https://deq.nc.gov/about/divisions/waste-management/hw/provisional-notification>

Testing labs shall be certified in accordance with North Carolina State Laboratory Public Health Environmental Sciences. List of certified laboratories may be obtained at:

<https://slphreporting.ncpublichealth.com/Certification/CertifiedLaboratory.asp>

All test results shall be documented on the lab analysis as follows:

(A) For leachable lead:

(1) Soils/Solid/Liquid- EPA 1311/200.7/6010

Area sampling will be performed for the first two (2) days at each bridge location. The area sample will be located within five (5) feet of the containment and where the highest probability of leakage will occur (access door, etc.). Results from the area sampling will be given to the Engineer within 72 hours of sampling (excluding weekends). If the results of the samples exceed  $20 \mu\text{g}/\text{m}^3$  corrective measures shall be taken and monitoring shall be continued until two (2) consecutive sample results are less than  $20 \mu\text{g}/\text{m}^3$ .

Time Weighted Average (TWA) may suspend the work if there are visible emissions outside the containment enclosure or pump monitoring results exceeding the level of  $30 \mu\text{g}/\text{m}^3$ .

Where schools, housing and/or buildings are within 500 feet of the containment, the Contractor shall perform initial Total Suspended Monitoring (TSP) Lead monitoring for the first ten (10) days of the project during abrasive blasting, vacuuming and containment removal. Additional monitoring will be required during abrasive blasting two (2) days per month thereafter. Results of the TSP monitoring at any location shall not exceed  $1.5 \mu\text{g}/\text{m}^3$ .

**EQUIPMENT MOBILIZATION**

The equipment used in any travel lanes and paved shoulder shall be mobile equipment on wheels that has the ability to move on/off the roadway in less than 30 minutes. All work conducted in travel lanes shall be from truck or trailer supported platforms and all equipment shall be self-propelled or attached to a tow vehicle at all times.

**QUALITY CONTROL INSPECTOR**

Provide a quality control (QC) inspector in accordance with the SSPC QP guidelines to ensure that all processes, preparation, blasting and coating application are in accordance with the requirements of the contract. The inspector shall have written authority to perform QC duties to include continuous improvement of all QC internal procedures. The presence of the engineer or inspector at the work site shall in no way lessen the contractor's responsibility for conformity with the contract.

**QUALITY ASSURANCE INSPECTOR**

The quality assurance inspector which may be a Department employee or a designated representative of the Department shall observe, document, assess, and report that the Contractor is complying with all of the requirements of the contract. Inspectors employed by the Department are authorized to inspect all work performed and materials furnished. Such inspection may extend to all or any part of the work and to the preparation, fabrication, or manufacture of the materials to be used. The inspector is not authorized to alter or waive the requirements of the contract. Each stage in preparing the structure to be coated which includes but not limited to washing, blasting, coating testing and inspection shall be inspected and approved by the Engineer or an authorized representative.

**SUBLETTING OF CONTRACT**

Only contractors certified to meet SSPC QP 2, Category A, and have successfully completed lead paint removal and field painting on all similar structures within 18 months prior to this bid are qualified for this work. Work is only sublet by approval of the Engineer.

**LIMITS OF ZONE PAINTING**

If any girder has excessive corrosion along its bottom flange, beyond the distance of 1.5 times the depth of the beam or girder, at the bearing, the area of the affected girder indicated on the plans, and other girders as directed by the Engineer, shall be cleaned in accordance with the requirements of System 5 painting system. The horizontal limits of zone painting shall extend 12" beyond the maximum horizontal extent of web/flange corrosion. The vertical limits of zone painting shall extend 3" beyond the maximum vertical extent of web corrosion.

Areas designated for zone coating shall be primed and coated in accordance with System 5 as outlined in Article 442-8 of the *Standard Specifications*.

System 5 is one coat of primer, one intermediate acrylic coat, one stripe coat of paint, and one topcoat of paint and over non-weathering steel surfaces cleaned to an SSPC SP-6 finish.

Painting shall be performed in accordance with Section 442 and Section 1080 of the *Standard Specifications*, and/ or these special provisions; the more restrictive requirement shall apply. Perform

all mixing operations over an impervious surface with provisions to prevent runoff to grade of any spilled material.

### **PREPARATION OF SURFACES**

Before any other surface preparation is conducted, all surfaces shall be power washed to remove dust, salts, dirt, and other contaminants. All wash water shall be contained, collected, and tested in accordance with the requirements of NCDOT Guidelines for Managing Bridge Wash Water. Obtain approval of the Engineer and allow all cleaned surfaces to dry to the touch and without standing water before beginning surface preparation or painting activities.

Surface preparation is done with materials meeting Article 1080-12 of the *Standard Specifications*. No silica sand or other silica materials are permitted for use. The profile shall be between 1.0 and 3.0 mils when measured on a smooth steel surface. Conduct and document at least two (2) tests per beam/girder and two (2) tests per span of diaphragms/cross bracing.

Spread tarpaulins over all pavements and surfaces underneath equipment used for abrasive blasting as well as equipment and containers used to collect abrasive media. This requirement will be enforced during activity and inactivity of equipment.

Before the Contractor departs from the work site at the end of the workday, collect all debris generated during surface preparation and all dust collector hoses, tarps or other appurtenances containing blasting residue in approved containers.

Clean a 3" x 3" area at each structure to demonstrate the specified finish, and the inspector will preserve this area by covering it with tape, plastic or some other suitable means so that it can be retained as the Dry Film Thickness (DFT) gauge adjustment standard. An acceptable alternative is for the Contractor to provide a steel plate with similar properties and geometry as the substrate to be measured.

The contractor and or quality assurance representative shall notify the Engineer of any area of corroded steel that has lost more than 50% of its original thickness.

All parts of the bridges not to be painted and the travelling public shall be protected from overspray. Submit a plan to protect all parts of bridge that are not required to be painted and a plan to protect the traveling public and surrounding environment while applying all coats of paint to a structure.

Ensure that chloride levels on the surfaces are  $7 \mu\text{g}/\text{cm}^2$  or lower using an acceptable sample method in accordance with SSPC Guide 15. The frequency of testing shall be two (2) tests per span after all surface preparation has been completed and immediately prior to painting. Select test areas representing the greatest amount of corrosion in the span as determined by the Engineers' representative. Additional testing may be required if significant amounts of chloride are detected.

All weld splatter, slag or other surface defects resulting in a raised surface above the final paint layer shall be removed prior to application of primer coat.

### **PAINTING OF STEEL**

Paint System 5, as specified in these special provisions and Article 442-8 of the *Standard Specifications*, is to be used for this work. System 5 is one coat of primer, one intermediate acrylic coat, one stripe coat

of paint, and one topcoat of paint over non-weathering steel surfaces blast-cleaned surfaces in accordance with SSPC-SP-6 (Commercial Blasting). Perform all mixing operations over an impervious surface with provisions to prevent runoff to grade of any spilled material. The contractor is responsible for reporting quantities of thinner purchased as well the amounts used. No container with thinner shall be left uncovered, when not in use.

Apply 2" stripe coat, by brush or roller only, to all exposed edges of steel including fasteners before applying the finish coat. Locate the edge or corner in the approximate center of the paint stripe.

Any area where newly applied paint fails to meet the specifications shall be repaired or replaced by the Contractor, at no additional cost to the Department. The Engineer approves all repair processes before the repair is made. Repaired areas shall meet the *Standard Specifications*. The Contractor applies an additional finish coat of paint to areas where the tape adhesion test is conducted.

### **MATERIALS**

Only paint suppliers that have a NCDOT qualified inorganic zinc primer may furnish paints for this project. All paints applied to a structure shall be from the same supplier. Before any paints are applied the Contractor shall provide the Engineer a manufacturer's certification that each batch of paint meets the requirements of the applicable Section 1080 of the *Standard Specifications*.

Color of the paint shall match that of the existing paint on the structure steel.

The inspector randomly collects a one pint sample of each paint product used on the project. Additional samples may be collected as needed to verify compliance to the specifications.

Do not expose paint materials to rain, excessive condensation, long periods of direct sunlight, or temperatures above 110°F or below 40°F. In addition, the Contractor shall place a device that records the high, low, and current temperatures inside the storage location. Follow the manufacturer's storage requirements if more restrictive than the above requirements.

### **INSPECTION**

Surface Preparation for System 5 shall be in accordance with SSPC SP-6. Any area(s) not meeting the requirements of SSPC SP-6 shall be remediated prior to application of coating. Surface inspection is considered ready for inspection when all blast abrasive, residue and dust is removed from surfaces to be coated.

#### **(A) Quality Assurance Inspection**

The Contractor furnishes all necessary OSHA approved apparatus such as ladders, scaffolds and platforms as required for the inspector to have reasonable and safe access to all parts of the work. The contractor illuminates the surfaces to be inspected to a minimum of 50-foot candles of light. All access points shall be illuminated to a minimum of 20-foot candles of light.

NCDOT reserves the right for ongoing Quality Assurance (QA) inspection to include but not limited to surface contamination testing, adhesion pull testing, and DFT readings as necessary to assure quality.

Inform the Engineer and the Division Safety Engineer of all scheduled and unannounced inspections from SSPC, OSHA, EPA and/or others that come on site. Furnish the Engineer a copy of all inspection reports except for reports performed by a third party and or consultant on behalf of the Contractor.

(B) Inspection Instruments

At a minimum, furnish the following calibrated instruments and conduct the following quality control tests:

- (1) Sling Psychrometer - ASTM E337 - bulb type
- (2) Surface Temperature Thermometer
- (3) Wind Speed Indicator
- (4) Tape Profile Tester - ASTM D4417 Method C
- (5) Surface Condition Standards - SSPC VIS-1 and VIS-3
- (6) Wet Film Thickness Gage - ASTM D4414
- (7) Dry Film Thickness Gage - SSPC-PA2 Modified
- (8) Solvent Rub Test Kit - ASTM D4752
- (9) Adhesion Test Kit - ASTM D3359 Method A (Tape Test)
- (10) Adhesion Pull test - ASTM D4541
- (11) Surface Contamination Analysis Kit or (Chloride Level Test Kit) SSPC Technology Guide 15

(C) Quality Control

Maintain a daily quality control record in accordance with Subarticle 442-12(D) of the *Standard Specifications* and make such records available at the job site for review by the inspector and submit to the Engineer as directed. In addition to the information required on Form M&T-610, submit all Dry Film Thickness (DFT) readings on a form equivalent to Form M&T-611. These forms can be found at:

<https://connect.ncdot.gov/resources/Materials/Pages/Materials-Manual-by-Material.aspx?Order=MM-03-02>

- (1) Measure DFT at each spot on the attached diagram and at the required number of locations as specified below:



- (a) For span members less than 45 feet; three (3) random locations along each girder in each span.
- (b) For span members greater than 45 feet; add one additional location for each additional ten (10) feet in span length.

DFT measurements for the prime coat shall not be taken for record until the zinc primer has cured in accordance with ASTM D4752 (MEK Rub Test) with no less than a four (4) resistance rating.

Stiffeners and other attachments to beams and or plate girders shall be measured at no less than five (5) random spots per span. Also, dry film thickness is measured at no less than six (6) random spots per span on diaphragms/cross frames.

Each spot is an average of three (3) to five (5) individual gage readings as defined in SSPC PA-2. No spot average shall be less than 80% of minimum DFT for each layer applied; this does not apply to stripe coat application. Spot readings that are non-conforming shall be re-assessed by performing additional spot measurements not to exceed one-foot intervals on both sides of the low areas until acceptable spot averages are obtained. These non-conforming areas shall be corrected by the Contractor prior to applying successive coats.

**Less than 36" in height and/or bottom flanges less than 16" in width.**  
**7 Spot Areas**  
**21 Individual DFT Readings**

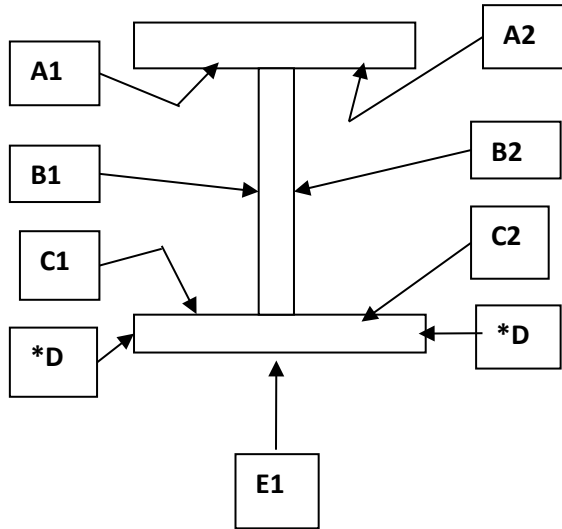

**\*D areas are only included when flange thickness is one inch (1") or greater.**

**36" in height or greater and/or bottom flanges greater than 16" in width.**  
**10 Spot Areas**  
**30 Individual DFT Readings**

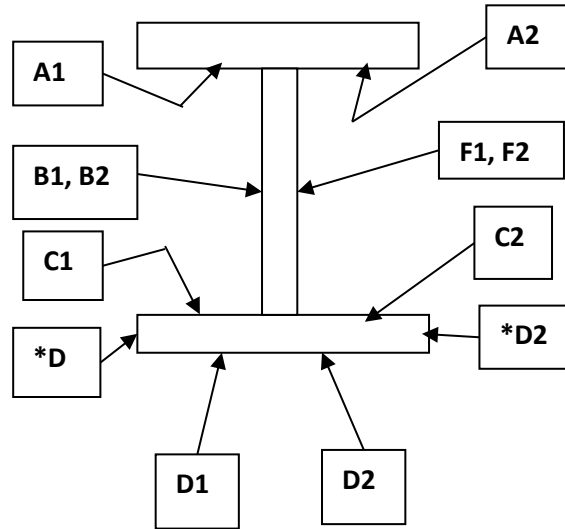

**\*D areas are only included when flange thickness is one inch (1") or greater.**

- (2) Two (2) random adhesion tests (1 test = 3 dollies) per span are conducted on interior surfaces in accordance with ASTM D4541 (Adhesion Pull Test) after the prime coat has been properly cured in accordance with ASTM D3363 (Pencil Hardness) with no less than 2H, and will be touched up by the Contractor. The required minimum average adhesion is 400 psi.
- (3) Cure of the intermediate and stripe coats shall be accessed by using the thumb test in accordance with ASTM D1640 (Curing Formation Test) prior to the application of any successive layers of paint.
- (4) One random Cut Tape adhesion test per span is conducted in accordance with ASTM D3359 (X-Cut Tape Test) on interior surface after the finish coat is cured. Repair areas shall be properly tapered and touched up by the Contractor.

**ZONE PAINTING**

If any girder has excessive corrosion along its bottom flange, beyond the distance of 1.5 times the depth of the beam or girder, at the bearing, the area of the affected girder indicated on the plans, and other girders as directed by the Engineer, shall be cleaned in accordance with the requirements of System 5 painting system. The horizontal limits of zone painting shall extend 12" beyond the maximum horizontal extent of web/flange corrosion. The vertical limits of zone painting shall extend 3" beyond the maximum vertical extent of web corrosion.

Areas designated for zone coating shall be primed and coated in accordance with System 5 as outlined in the *Structural Steel Shop Coatings Program*.

System 5 is one coat of primer, one intermediate acrylic coat, one stripe coat of paint, and one topcoat of paint and over non-weathering steel surfaces cleaned to an SSPC SP-6 finish.

Painting shall be performed in accordance with Section 442 and Section 1080 of the *Standard Specifications*, and/ or these special provisions; the more restrictive requirement shall apply. Perform all mixing operations over an impervious surface with provisions to prevent runoff to grade of any spilled material.

#### **SAFETY AND ENVIRONMENTAL COMPLIANCE PLANS**

Personnel access boundaries are delineated for each work site using signs, tape, cones, or other approved means. Submit copies of safety and environmental compliance plans that comply with SSPC QP 2 Certification requirements.

#### **HEALTH AND SAFETY RESPONSIBILITIES**

This project may involve toxic metals such as arsenic, lead, cadmium and hexavalent chromium. It is the contractor's responsibility to test for toxic metals and if found, comply with the OSHA regulations, which may include medical testing.

Ensure a "Competent Person" as defined in OSHA 29 CFR 1926.62; one who is capable of identifying existing and predictable hazards in the surroundings or working conditions which are unsanitary, hazardous, or dangerous to employees, and who has authorization to take prompt corrective measures to eliminate them; is on site during all surface preparation activities and monitors the effectiveness of containment, dust collection systems and waste sampling. Before any work begins, provide a written summary of the Competent Person's safety training.

Comply with Subarticle 442-14(B) of the *Standard Specifications*.

Comply with Subarticle 442-14(D) of the *Standard Specifications*. Ensure employee blood sampling test results are less than 50 micrograms per deciliter. Remove employees with a blood sampling test of 50 or more micrograms per deciliter from work activities involving any lead exposure.

An employee who has been removed with a blood level of 50 micrograms per deciliter or more shall have two (2) consecutive blood sampling tests spaced one week apart indicating that the employee's blood lead level is at or below 40 micrograms per deciliter before returning to work activities involving any lead exposure.

All OSHA recordable accidents that occur during the project duration are to be reported to the Engineer within twenty-four (24) hours of occurrence. In addition, for accidents that involve civilians or property damage that occurs within the work zone the Division Safety Engineer shall be notified immediately.

Prior to blasting operations, the Contractor shall have an operational OSHA approved hand wash station at each bridge location and a decontamination trailer at each bridge or between bridges unless the work is on the roadway, or the Contractor shall show reason why it is not feasible to do so and provide an

alternative site as approved by the Engineer. The Contractor shall assure that all employees whose airborne exposure to lead is above the Permissible Exposure Limit (PEL) shall shower at the end of their work shift.

**STORAGE OF PAINT AND EQUIPMENT**

Provide a location for materials, equipment, and waste storage. Spread tarpaulins over all pavements and surfaces underneath equipment used for abrasive recycling and other waste handling equipment or containers. All land and or lease agreements that involve private property shall disclose to the property owner that heavy metals may be present on the Contractor’s equipment. Prior to storing the Contractor’s equipment on private property, provide a notarized written consent signed by the land owner received by the Engineer at least forty-eight (48) hours before using property. All storage of paint, solvents, and other materials applied to structures shall be stored in accordance with Subarticle 442-9(C) of the *Standard Specifications* or the manufacturers’ requirements. The more restrictive requirements will apply.

**UTILITIES**

Protect all utility lines or mains that may be supported on, under, or adjacent to bridge work sites from damage and paint overspray.

**MEASUREMENT AND PAYMENT**

The cost of inspection, surface preparation and repainting the existing structure is included in the lump sum price bid for *Cleaning and Painting Existing Weathering Steel for Bridge #\_\_\_*. This price is full compensation for furnishing all inspection equipment, all paint, cleaning abrasives, cleaning solvents and all other materials; preparing and cleaning surfaces to be painted; applying paint in the field; protecting work area, traffic and property; furnishing blast cleaning equipment, paint spraying equipment, brushes, rollers, any other hand or power tools and any other equipment.

*Pollution Control* will be paid at the contract lump sum price which will be full compensation for all collection, handling, storage, air monitoring, and disposal of debris and wash water, all personal protective equipment, and all personal hygiene requirements, and all equipment, material and labor necessary for the daily collection of the blast debris into specified containers; and any measures necessary to ensure conformance to all safety and environmental regulations as directed by the Engineer.

*Painting Containment for Bridge #\_\_\_* will be paid at the lump sum contract price and will be full compensation for the design, materials, installation, maintenance, and removal of the containment system.

Payment will be made under:

<b>Pay Item</b>	<b>Pay Unit</b>
Cleaning and Painting Existing Weathering Steel for Bridge #___	Lump Sum
Pollution Control	Lump Sum
Painting Containment for Bridge #___	Lump Sum

**PAINTING EXISTING STRUCTURE****(2-11-19)****DESCRIPTION**

This work shall consist of furnishing all labor, equipment, and materials necessary to clean and paint the structural steel of the existing bridge. Work includes: removal, containment and disposal of the existing paint system; preparation of the surface to be painted and applying the new paint system; a containment enclosure; and any incidentals necessary to complete the project as specified and shown on the plans.

**DESCRIPTION OF BRIDGE**

**Bridge #306:** This bridge was built in 2001 and carries SR1118 (Fayetteville Rd.) over I-40. The superstructure consists of 2 spans with 21 lines of steel plate girders at varying spacing with steel diaphragms. The bridge has an overall length of 207'-10½" with a concrete deck and a varying deck width with 265'-11 5/16" total deck width. The minimum vertical clearance is 17'-5". The existing paint system is acrylic over inorganic zinc, and the estimated area to be cleaned and painted is **100,681** sq. ft.

**TWELVE-MONTH OBSERVATION PERIOD**

The Contractor maintains responsibility for the coating system for a 12-month observation period beginning upon the satisfactory completion of all the work required in the plans or as directed by the Engineer. The Contractor shall guarantee the coating system under the payment and performance bond (refer to Article 109-10 of the *Standard Specifications*). To complete successfully the observation period, the coating system shall meet the following requirements after 12 months service:

- (A) No visible rust, contamination or application defect is observed in any coated area.
- (B) Painted surfaces have a uniform color and gloss.
- (C) Painted surfaces have an adhesion that meets an ASTM D3359, 3A rating.

Final acceptance is made only after the paint system meets the above requirements.

**SUBMITTALS**

Submit all of the following to the Engineer for review and approval before scheduling the pre-construction meeting. Allow at least two (2) weeks for the review process.

- (B) The existing paint systems include toxic substances such as red lead oxide, which are considered hazardous if improperly removed. The contractor shall be currently Society for Protective Coatings (SSPC) Quality Program (QP) 2, Category A certified, and have successfully completed lead paint removal and field painting on similar structures within 18 months prior to this bid. Lead abatement work completed within the 18 month period shall have been completed in accordance with contract specifications, free of citation from safety or environmental agencies. Lead abatement work shall include, but not be limited to: abrasive blasting; waste handling, storage and disposal; worker safety during lead abatement activities (fall protection, personal protective equipment (PPE), etc.); and containment. This requirement is in addition to the

contractor pre-qualification requirements covered by Article 102-2 of the *Standard Specifications*.

The apparent low bidder shall submit a list of projects for which QP 2 work was performed within the last 18 months including owner contact information and submit to the Engineer a "Lead Abatement Affidavit". See link for form: <https://www.ncdot.gov/initiatives-policies/Transportation/bridges/Documents/leadabatementaffidavit.pdf>.

- (M) Work schedule which shall be kept up to date, with a copy of the revised schedule being provided to the Engineer in a timely manner.
- (N) Containment system plans and design calculations in accordance with SSPC Guide 6, Class 2A and other project requirements, signed and sealed by a Professional Engineer licensed by the State of North Carolina.
- (O) Bridge wash water sampling and disposal plan.
- (P) Subcontractor identification.
- (Q) Lighting plan for night work in accordance with Section 1413 of the *Standard Specifications*.
- (R) Traffic control plan with NCDOT certified supervisors, flaggers and traffic control devices.
- (S) Health and safety plan addressing at least the required topics as specified by the SSPC QP 1 and QP 2 program and including hazard communication, respiratory health, emergency procedures, and local hospital and treatment facilities with directions and phone numbers, disciplinary criteria for workers who violate the plan and accident investigation. The plan shall address the following: hazardous materials, personal protective equipment, general health and safety, occupational health and environmental controls, fire protection and prevention, signs signals, and barricades, materials handling, storage, use, and disposal, hand and power tools, welding and cutting, electrical, scaffolds, fall protection, cranes, derricks, hoists, elevators, and conveyors, ladders, toxic and hazardous substances, airless injection and high pressure water jet (HPWJ).
- (T) Provide the Engineer a letter of certification that all employees performing work on the project have blood lead levels that are below the Occupational Safety and Health Administration (OSHA) action level.
- (U) Provide the Engineer with Competent Person qualifications and summary of work experience.
- (V) Environmental Compliance Plan.
- (W) Quality Control Plan (Project Specific) with quality control qualifications and summary of work experience.
- (P) Bridge and Public Protection Plan (Overspray, Utilities, etc. - Project/Task Specific).
- (Q) Abrasive Blast Media:
  - (3) Product Data Sheet.
  - (4) Blast Media Test Reports in accordance with Article 1080-12 of the *Standard Specification*.
- (R) Coating Material:
  - (6) NCDOT HICAMS Test Reports (testing performed by NCDOT Materials and Tests Unit).
  - (7) Product Data Sheets.
  - (8) Material Safety Data Sheets.

(9) Product Specific Repair Procedures.

(10) Acceptance letters from paint manufacturer's for work practices that conflict with special provisions and/or paint manufactures product data sheets.

#### **PRE-CONSTRUCTION MEETING**

Submittals shall be reviewed and approved by the Engineer prior to scheduling the pre-construction meeting. Allow no less than two (2) weeks for a review process. When requesting a pre-construction meeting, contact the Engineer at least seven (7) working days in advance of the desired pre-construction date. The contractor's project supervisor, Competent Person, quality control personnel and certified traffic control supervisor shall be in attendance at the pre-construction meeting in order for the Contractor and NCDOT team to establish responsibilities for various personnel during project duration and to establish realistic timeframes for problem escalation.

#### **CONTAINMENT SYSTEM**

Prior to performing any construction or painting operations on the structure, the Contractor shall furnish the Engineer with plans and design calculations for a sufficiently designed containment system, which will provide access for any repairs on structural steel members, cleaning and surface preparations for structural steel members, and coating operations for structural steel members of the bridge. The containment system shall not be installed, and no work shall begin, until the Engineer has reviewed and approved, in writing, the submitted containment system plans and design calculations. Containment system plans and design calculations shall be prepared, sealed, and signed by a Professional Engineer licensed by the State of North Carolina. Allow a minimum of two (2) weeks for review of the containment plans and calculations.

The containment system shall meet or exceed the requirements of Class 2A containment in accordance with SSPC Guide 6. The Contractor shall determine the required capacity of the containment system, which, at a minimum, shall include loads due to wind, repair materials and repair operations, equipment, and tools; however, the capacity shall not be less than that required by Federal or State regulations. Design steel members to meet the requirements of the *American Institute of Steel Construction Manual*. Design timber members in accordance with the *National Design Specification for Stress-Grade Lumber and Its Fastenings* of the National Forest Products Association. The containment system shall be constructed of materials capable of withstanding damage from any of the work required on this project and shall provide a two (2) hour resistance to fire.

In the containment system plans, describe how debris is contained and collected. Describe the type of tarpaulin, bracing materials, and the maximum designed wind load. Design wind loads shall be in accordance with the Falsework and Formwork special provision. Describe the dust collection system and how a negative pressure of 0.03 inches of water column is maintained inside the enclosure, while blasting operations are being conducted. Describe how the airflow inside the containment structure is designed to meet all applicable OSHA Standards. Describe how water run-off from rain will be routed by or through the enclosure. Describe how wash water will be contained and paint chips separated. Describe what physical containment will be provided during painting application to protect the public and areas not to be painted.

Drilling holes in the superstructure for the purpose of attaching the containment system is prohibited.

The Contractor will be responsible for certifying the containment system has been constructed in accordance with the approved plans.

The containment system shall be cleaned after each workday.

Upon completion of work, remove all anchorages in the substructure and repair the substructure at no additional cost to the Department.

Protect non-metallic parts of bearings from blasting and painting (i.e.: Pot Bearings, Elastomeric Pads, and Disc Bearings).

#### **WASH WATER SAMPLING AND DISPOSAL PLAN**

All wash water shall be collected and sampled prior to disposal. Representative sampling and testing methodology shall conform to North Carolina Administrative Code 15A NCAC 02B.0103, "Analytical Procedures". Wash water shall be tested for pollutants listed in 15A NCAC 02B.0211(3), 15A NCAC 02T.0505(b)(1) and 15A NCAC 2T.0905(h). Depending on the test results, wash water disposal methods shall be described in the disposal plan. Wash water shall be disposed of in accordance with all current Federal and State regulations. See link for NCDOT Guidelines for Managing Bridge Wash Water: <https://www.ncdot.gov/initiatives-policies/Transportation/bridges/Documents/WashWater.pdf>

#### **WASTE HANDLING OF PAINT AND ABRASIVES**

Comply with all Federal, State, and local regulations. Failure to comply with the regulations could result in fines and loss of qualified status with NCDOT.

Comply with the Resource Conservation and Recovery Act (RCRA - 40 CFR 261 - 265) and the Occupational Safety and Health Act (OSHA - 29 CFR 1910 - 1926) regulations for employee training, and for the handling, storage, labeling, recordkeeping, reporting, inspections and disposal of all hazardous waste generated during paint removal.

A summary of Generator Requirements is available at the above NCDOT web link, which cites the specific regulations for each Generator category. Quantities of waste by weight and dates of waste generation shall be recorded. Waste stored at the project site shall be properly labeled. All waste, hazardous or non-hazardous, requires numbered shipping manifests.

The North Carolina Department of Environmental Quality (NCDEQ) have adopted RCRA as the North Carolina Hazardous Waste Management Rules and are responsible for enforcement. The *Hazardous Waste Generator Compliance Manual* is published by the Compliance Branch of the Division of Waste Management of NCDEQ, and can be found at: <https://files.nc.gov/ncdeq/Waste%20Management/DWM/HW/Compliance/Generator%20Compliance%20Manual.pdf>

Immediately after award of the contract, arrange for waste containers, sampling, testing, transportation, and disposal of all waste. No work shall begin until the Contractor furnishes the Engineer with a written waste disposal plan. Any alternative method for handling waste shall be pre-approved by the Engineer. Use an approved waste management company from the following link:

<https://www.ebs.nc.gov/VendorDirectory/results.html?sap-params=cD0xJTIwJmN1cnJlbnRfc2VhcmNoX3BhZ2U9d2Mmc2VsZWNoaW9uX2Zpcm1fbmFtZT>



[0mc2VsZWN0aW9uX2NlcnQ9JnNlbGVjdGlvb19maXJtdHlwZT0meXNjX2Zpcm10eXBIPSZzZWxIY3Rpb25fd29ya2xvY2F0aW9uPSZ5c2Nfd29ya2xvY2F0aW9uPSZzZWxIY3Rpb25fYWRkcnN0YXRIPSZ5c2NfYWRkcnN0YXRIPSZzZWxIY3Rpb25fYWRkcmNvdW50eT0meXNjX2FkZHIjb3Vu dHk9JnNlbGVjdGlvb193a2NvZGU9MDAzMDQwJnlzY193a2NvZGU9MDAzMDQwJTIwQ09OV EFNSU5BVEVEJTIwTUFURVJJQUxTJTlwUkVNT1ZBTCZzZWxIY3Rpb25fZGlzYz0meXNjX2 Rpc2M9JnNlbGVjdGlvb19uYWljcz0meXNjX25haWNzPSZzZWxIY3Rpb25fY3R5cGU9MA%3d% 3d](https://ncdenr.s3.amazonaws.com/s3fs-public/document-library/Lead%20Disposal.pdf)

All removed paint and spent abrasive media shall be tested for lead following the SW-846 Toxicity Characteristic Leaching Procedure (TCLP) Method 1311 Extraction, as required in 40 CFR 261, Appendix 11, to determine whether it shall be disposed of as hazardous waste. Furnish the Engineer certified test reports showing TCLP results of the paint chips stored on site, with disposal in accordance with “Flowchart on Lead Waste Identification and Disposal” at:

<https://ncdenr.s3.amazonaws.com/s3fs-public/document-library/Lead%20Disposal.pdf>

All sampling shall be done in presence of the Engineer’s representative.

The Competent Person shall obtain composite samples from each barrel of the wash water and waste generated by collecting two or more portions taken at regularly spaced intervals during accumulation. Composite the portions into one sample for testing purposes. Acquire samples after 10% or before 90% of the barrel has accumulated. The intent is to provide samples that are representative of widely separated portions, but not the beginning and end of wash water or waste accumulation.

Perform sampling by passing a receptacle completely through the discharge stream or by completely diverting the discharge into a sample container. If discharge of the wash water or waste is too rapid to divert the complete discharge stream, discharge into a container or transportation unit sufficiently large to accommodate the flow and then accomplish the sampling in the same manner as described above.

Comply with the NCDEQ *Hazardous Waste Compliance Generator Manual*. Record quantities of waste by weight and dates of waste generation. Until test results are received, store all waste, and label as “NCDOT Bridge Paint Removal Waste - Pending Analysis” and include the date generated and contact information for the Engineer. Store waste containers in an enclosed, sealed, and secured storage container protected from traffic from all directions. Obtain approval for the protection plan for these containers from the Engineer. If adequate protection cannot be obtained by use of existing guardrail, provide the necessary supplies and equipment to maintain adequate protection. Once test results are received and characterized, label waste as either “Hazardous Waste - Pending Disposal” or “Paint Waste - Pending Disposal”.

Once the waste has been collected, and the quantities determined, prepare the appropriate shipping documents and manifests and present them to the Engineer. The Engineer will verify the type and quantity of waste and obtain a Provisional Environmental Protection Agency (EPA) ID number from:

Melodi Deaver  
Division of Waste Management/Hazardous Waste Section  
North Carolina Department of Environmental Quality  
1646 Mail Service Center  
Raleigh, NC 27699  
Phone: (919) 707-8204, Email: [melodi.deaver@ncdenr.gov](mailto:melodi.deaver@ncdenr.gov)

At the time of shipping, the Engineer will sign, date, and add the ID number in the appropriate section on the manifest. The maximum on-site storage time for collected waste shall be 90 calendar days. All waste whether hazardous or non-hazardous will require numbered shipping manifests. The cost for waste disposal (including lab and Provisional EPA ID number) is included in the bid price for this contract. Note NC Hazardous Waste Management Rules (15A NCAC 13A) for more information. Provisional EPA ID numbers may be obtained at:

<https://deq.nc.gov/about/divisions/waste-management/hw/provisional-notification>

Testing labs shall be certified in accordance with North Carolina State Laboratory Public Health Environmental Sciences. List of certified laboratories may be obtained at:

<https://slphreporting.ncpublichealth.com/Certification/CertifiedLaboratory.asp>

All test results shall be documented on the lab analysis as follows:

(B) For leachable lead:

(1) Soils/Solid/Liquid- EPA 1311/200.7/6010

Area sampling will be performed for the first two (2) days at each bridge location. The area sample will be located within five (5) feet of the containment and where the highest probability of leakage will occur (access door, etc.). Results from the area sampling will be given to the Engineer within 72 hours of sampling (excluding weekends). If the results of the samples exceed  $20 \mu\text{g}/\text{m}^3$  corrective measures shall be taken and monitoring shall be continued until two (2) consecutive sample results are less than  $20 \mu\text{g}/\text{m}^3$ .

Time Weighted Average (TWA) may suspend the work if there are visible emissions outside the containment enclosure or pump monitoring results exceeding the level of  $30 \mu\text{g}/\text{m}^3$ .

Where schools, housing and/or buildings are within 500 feet of the containment, the Contractor shall perform initial Total Suspended Monitoring (TSP) Lead monitoring for the first ten (10) days of the project during abrasive blasting, vacuuming and containment removal. Additional monitoring will be required during abrasive blasting two (2) days per month thereafter. Results of the TSP monitoring at any location shall not exceed  $1.5 \mu\text{g}/\text{m}^3$ .

## **EQUIPMENT MOBILIZATION**

The equipment used in any travel lanes and paved shoulder shall be mobile equipment on wheels that has the ability to move on/off the roadway in less than 30 minutes. All work conducted in travel lanes shall be from truck or trailer supported platforms and all equipment shall be self-propelled or attached to a tow vehicle at all times.

## **QUALITY CONTROL INSPECTOR**

Provide a quality control (QC) inspector in accordance with the SSPC QP guidelines to ensure that all processes, preparation, blasting and coating application are in accordance with the requirements of the contract. The inspector shall have written authority to perform QC duties to include continuous improvement of all QC internal procedures. The presence of the engineer or inspector at the work site shall in no way lessen the contractor's responsibility for conformity with the contract.

**QUALITY ASSURANCE INSPECTOR**

The quality assurance inspector which may be a Department employee or a designated representative of the Department shall observe, document, assess, and report that the Contractor is complying with all of the requirements of the contract. Inspectors employed by the Department are authorized to inspect all work performed and materials furnished. Such inspection may extend to all or any part of the work and to the preparation, fabrication, or manufacture of the materials to be used. The inspector is not authorized to alter or waive the requirements of the contract. Each stage in preparing the structure to be coated which includes but not limited to washing, blasting, coating testing and inspection shall be inspected and approved by the Engineer or an authorized representative.

**SUBLETTING OF CONTRACT**

Only contractors certified to meet SSPC QP 2, Category A, and have successfully completed lead paint removal and field painting on all similar structures within 18 months prior to this bid are qualified for this work. Work is only sublet by approval of the Engineer.

**PREPARATION OF SURFACES**

Before any other surface preparation is conducted, all surfaces shall be power washed to remove dust, salts, dirt, and other contaminants. All wash water shall be contained, collected, and tested in accordance with the requirements of NCDOT Guidelines for Managing Bridge Wash Water. Obtain approval of the Engineer and allow all cleaned surfaces to dry to the touch and without standing water before beginning surface preparation or painting activities.

Surface preparation is done with materials meeting Article 1080-12 of the *2 Standard Specifications*. No silica sand or other silica materials are permitted for use. The profile shall be between 1.0 and 3.0 mils when measured on a smooth steel surface. Conduct and document at least two (2) tests per beam/girder and two (2) tests per span of diaphragms/cross bracing.

Spread tarpaulins over all pavements and surfaces underneath equipment used for abrasive blasting as well as equipment and containers used to collect abrasive media. This requirement will be enforced during activity and inactivity of equipment.

Before the Contractor departs from the work site at the end of the workday, collect all debris generated during surface preparation and all dust collector hoses, tarps or other appurtenances containing blasting residue in approved containers.

Clean a 3" x 3" area at each structure to demonstrate the specified finish, and the inspector will preserve this area by covering it with tape, plastic or some other suitable means so that it can be retained as the Dry Film Thickness (DFT) gauge adjustment standard. An acceptable alternative is for the Contractor to provide a steel plate with similar properties and geometry as the substrate to be measured.

The contractor and or quality assurance representative shall notify the Engineer of any area of corroded steel that has lost more than 50% of its original thickness.

All parts of the bridges not to be painted and the travelling public shall be protected from overspray. Submit a plan to protect all parts of bridge that are not required to be painted and a plan to protect the traveling public and surrounding environment while applying all coats of paint to a structure.

Ensure that chloride levels on the surfaces are  $7 \mu\text{g}/\text{cm}^2$  or lower using an acceptable sample method in accordance with SSPC Guide 15. The frequency of testing shall be two (2) tests per span after all surface preparation has been completed and immediately prior to painting. Select test areas representing the greatest amount of corrosion in the span as determined by the Engineers' representative. Additional testing may be required if significant amounts of chloride are detected.

All weld splatter, slag or other surface defects resulting in a raised surface above the final paint layer shall be removed prior to application of primer coat.

### **PAINTING OF STEEL**

Paint System 1, as specified in these special provisions and Article 442-8 of the *Standard Specifications*, is to be used for this work. System 1 is an inorganic zinc primer, two coats acrylic paint, and one stripe coat of acrylic paint over blast-cleaned surfaces in accordance with SSPC-SP-10 (Near White Blast). Perform all mixing operations over an impervious surface with provisions to prevent runoff to grade of any spilled material. The contractor is responsible for reporting quantities of thinner purchased as well the amounts used. No container with thinner shall be left uncovered, when not in use.

Apply 2" stripe coat, by brush or roller only, to all exposed edges of steel including fasteners before applying the finish coat. Locate the edge or corner in the approximate center of the paint stripe.

Any area where newly applied paint fails to meet the specifications shall be repaired or replaced by the Contractor, at no additional cost to the Department. The Engineer approves all repair processes before the repair is made. Repaired areas shall meet the *Standard Specifications*. The Contractor applies an additional finish coat of paint to areas where the tape adhesion test is conducted.

### **MATERIALS**

Only paint suppliers that have a NCDOT qualified inorganic zinc primer may furnish paints for this project. All paints applied to a structure shall be from the same supplier. Before any paints are applied the Contractor shall provide the Engineer a manufacturer's certification that each batch of paint meets the requirements of the applicable Section 1080 of the *Standard Specifications*.

The inspector randomly collects a one pint sample of each paint product used on the project. Additional samples may be collected as needed to verify compliance to the specifications.

Do not expose paint materials to rain, excessive condensation, long periods of direct sunlight, or temperatures above 110°F or below 40°F. In addition, the Contractor shall place a device that records the high, low, and current temperatures inside the storage location. Follow the manufacturer's storage requirements if more restrictive than the above requirements.

### **INSPECTION**

Surface Preparation for System 1 shall be in accordance with SSPC SP-10. Any area(s) not meeting the requirements of SSPC SP-10 shall be remediated prior to application of coating. Surface inspection is considered ready for inspection when all blast abrasive, residue and dust is removed from surfaces to be coated.

(A) Quality Assurance Inspection

The Contractor furnishes all necessary OSHA approved apparatus such as ladders, scaffolds and platforms as required for the inspector to have reasonable and safe access to all parts of the work. The contractor illuminates the surfaces to be inspected to a minimum of 50-foot candles of light. All access points shall be illuminated to a minimum of 20-foot candles of light.

NCDOT reserves the right for ongoing Quality Assurance (QA) inspection to include but not limited to surface contamination testing, adhesion pull testing, and DFT readings as necessary to assure quality.

Inform the Engineer and the Division Safety Engineer of all scheduled and unannounced inspections from SSPC, OSHA, EPA and/or others that come on site. Furnish the Engineer a copy of all inspection reports except for reports performed by a third party and or consultant on behalf of the Contractor.

(B) Inspection Instruments

At a minimum, furnish the following calibrated instruments and conduct the following quality control tests:

- (1) Sling Psychrometer - ASTM E337 - bulb type
- (2) Surface Temperature Thermometer
- (3) Wind Speed Indicator
- (4) Tape Profile Tester - ASTM D4417 Method C
- (5) Surface Condition Standards - SSPC VIS-1 and VIS-3
- (6) Wet Film Thickness Gage - ASTM D4414
- (7) Dry Film Thickness Gage - SSPC-PA2 Modified
- (8) Solvent Rub Test Kit - ASTM D4752
- (9) Adhesion Test Kit - ASTM D3359 Method A (Tape Test)
- (10) Adhesion Pull test - ASTM D4541
- (11) Surface Contamination Analysis Kit or (Chloride Level Test Kit) SSPC Technology Guide

15

(C) Quality Control

Maintain a daily quality control record in accordance with Subarticle 442-12(D) of the *Standard Specifications* and make such records available at the job site for review by the inspector and submit to the Engineer as directed. In addition to the information required on Form M&T-610, submit all Dry Film Thickness (DFT) readings on a form equivalent to Form M&T-611. These forms can be found at:

<https://connect.ncdot.gov/resources/Materials/Pages/Materials-Manual-by-Material.aspx?Order=MM-03-02>

- (1) Measure DFT at each spot on the attached diagram and at the required number of locations as specified below:
  - (a) For span members less than 45 feet; three (3) random locations along each girder in each span.
  - (b) For span members greater than 45 feet; add one additional location for each additional ten (10) feet in span length.

DFT measurements for the prime coat shall not be taken for record until the zinc primer has cured in accordance with ASTM D4752 (MEK Rub Test) with no less than a four (4) resistance rating.

Stiffeners and other attachments to beams and or plate girders shall be measured at no less than five (5) random spots per span. Also, dry film thickness is measured at no less than six (6) random spots per span on diaphragms/cross frames.

Each spot is an average of three (3) to five (5) individual gage readings as defined in SSPC PA-2. No spot average shall be less than 80% of minimum DFT for each layer applied; this does not apply to stripe coat application. Spot readings that are non-conforming shall be re-assessed by performing additional spot measurements not to exceed one-foot intervals on both sides of the low areas until acceptable spot averages are obtained. These non-conforming areas shall be corrected by the Contractor prior to applying successive coats.

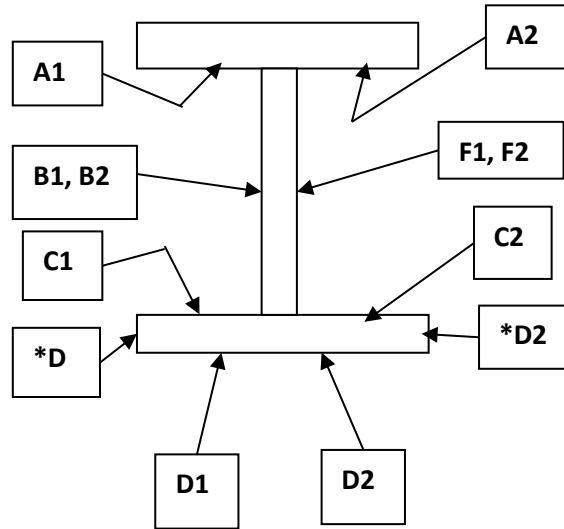
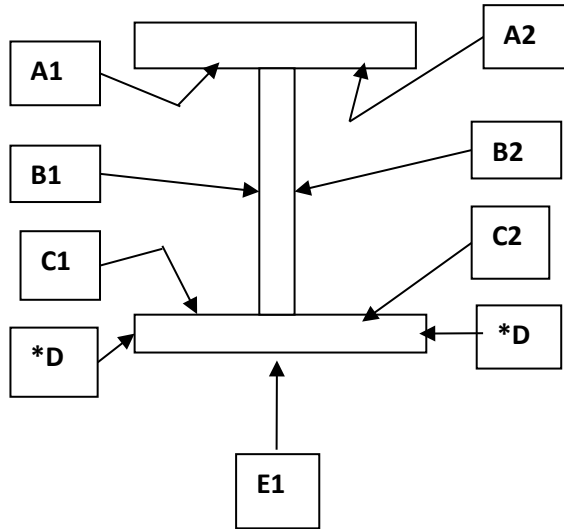
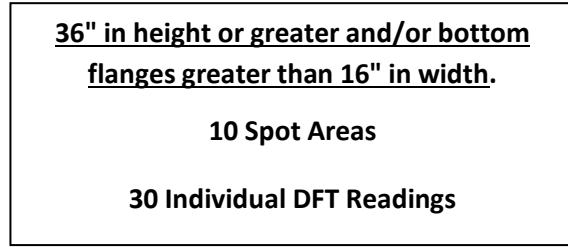
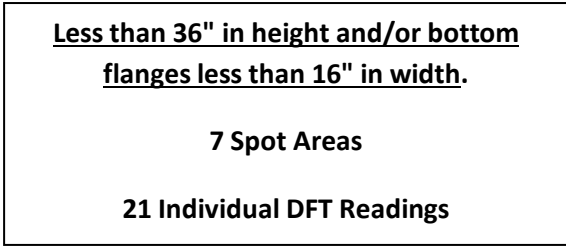

**\*D areas are only included when flange thickness is one inch (1") or greater.**

**\*D areas are only included when flange thickness is one inch (1") or greater.**

- (2) Two (2) random adhesion tests (1 test = 3 dollies) per span are conducted on interior surfaces in accordance with ASTM D4541 (Adhesion Pull Test) after the prime coat has been properly cured in accordance with ASTM D4752 (MEK Rub Test) with no less than a four (4) resistance rating, and will be touched up by the Contractor. The required minimum average adhesion is 400 psi.
- (3) Cure of the intermediate and stripe coats shall be accessed by using the thumb test in accordance with ASTM D1640 (Curing Formation Test) prior to the application of any successive layers of paint.
- (4) One random Cut Tape adhesion test per span is conducted in accordance with ASTM D3359 (X-Cut Tape Test) on interior surface after the finish coat is cured. Repair areas shall be properly tapered and touched up by the Contractor.

**SAFETY AND ENVIRONMENTAL COMPLIANCE PLANS**

Personnel access boundaries are delineated for each work site using signs, tape, cones, or other approved means. Submit copies of safety and environmental compliance plans that comply with SSPC QP 2 Certification requirements.

**HEALTH AND SAFETY RESPONSIBILITIES**

This project may involve toxic metals such as arsenic, lead, cadmium and hexavalent chromium. It is the contractor's responsibility to test for toxic metals and if found, comply with the OSHA regulations, which may include medical testing.

Ensure a "Competent Person" as defined in OSHA 29 CFR 1926.62; one who is capable of identifying existing and predictable hazards in the surroundings or working conditions which are unsanitary, hazardous, or dangerous to employees, and who has authorization to take prompt corrective measures to eliminate them; is on site during all surface preparation activities and monitors the effectiveness of containment, dust collection systems and waste sampling. Before any work begins, provide a written summary of the Competent Person's safety training.

Comply with Subarticle 442-14(B) of the *Standard Specifications*.

Comply with Subarticle 442-14(D) of the *Standard Specifications*. Ensure employee blood sampling test results are less than 50 micrograms per deciliter. Remove employees with a blood sampling test of 50 or more micrograms per deciliter from work activities involving any lead exposure.

An employee who has been removed with a blood level of 50 micrograms per deciliter or more shall have two (2) consecutive blood sampling tests spaced one week apart indicating that the employee's blood lead level is at or below 40 micrograms per deciliter before returning to work activities involving any lead exposure.

All OSHA recordable accidents that occur during the project duration are to be reported to the Engineer within twenty-four (24) hours of occurrence. In addition, for accidents that involve civilians or property damage that occurs within the work zone the Division Safety Engineer shall be notified immediately.

Prior to blasting operations, the Contractor shall have an operational OSHA approved hand wash station at each bridge location and a decontamination trailer at each bridge or between bridges unless the work is on the roadway, or the Contractor shall show reason why it is not feasible to do so and provide an alternative site as approved by the Engineer. The Contractor shall assure that all employees whose airborne exposure to lead is above the Permissible Exposure Limit (PEL) shall shower at the end of their work shift.

**STORAGE OF PAINT AND EQUIPMENT**

Provide a location for materials, equipment, and waste storage. Spread tarpaulins over all pavements and surfaces underneath equipment used for abrasive recycling and other waste handling equipment or containers. All land and or lease agreements that involve private property shall disclose to the property owner that heavy metals may be present on the Contractor's equipment. Prior to storing the Contractor's equipment on private property, provide a notarized written consent signed by the land owner received by the Engineer at least forty-eight (48) hours before using property. All storage of paint, solvents, and other materials applied to structures shall be stored in accordance with Subarticle 442-9(C) of the *Standard Specifications* or the manufacturers' requirements. The more restrictive requirements will apply.



**UTILITIES**

Protect all utility lines or mains that may be supported on, under, or adjacent to bridge work sites from damage and paint overspray.

**MEASUREMENT AND PAYMENT**

The cost of inspection, surface preparation, and repainting the existing structure is included in the lump sum price bid for *Cleaning and Repainting of Bridge #\_\_\_*. This price is full compensation for furnishing all inspection equipment, all paint, cleaning abrasives, cleaning solvents and all other materials; preparing and cleaning surfaces to be painted; applying paint in the field; protecting work area, traffic and property; and furnishing blast cleaning equipment, paint spraying equipment, brushes, rollers, any other hand or power tools and any other equipment.

*Pollution Control* will be paid at the contract lump sum price which will be full compensation for all collection, handling, storage, air monitoring, and disposal of debris and wash water, all personal protective equipment, and all personal hygiene requirements, and all equipment, material and labor necessary for the daily collection of the blast debris into specified containers; and any measures necessary to ensure conformance to all safety and environmental regulations as directed by the Engineer.

*Painting Containment for Bridge #\_\_\_* will be paid at the lump sum contract price and will be full compensation for the design, materials, installation, maintenance, and removal of the containment system.

Payment will be made under:

<b>Pay Item</b>	<b>Pay Unit</b>
Cleaning and Repainting of Bridge #___	Lump Sum
Pollution Control	Lump Sum
Painting Containment for Bridge #___	Lump Sum

**FOAM JOINT SEALS FOR PRESERVATION**

**(SPECIAL)**

**SEALS**

Use preformed seals compatible with concrete and resistant to abrasion, oxidation, oils, gasoline, salt, and other materials that are spilled on or applied to the surface. Use a resilient, UV stable, preformed, impermeable, flexible, expansion joint seal. The joint seal shall consist of low-density, closed cell, cross-linked polyethylene non-extrudable foam. The joint seal shall contain no EVA (Ethylene Vinyl Acetate). Cell generation shall be achieved by being physically blown using nitrogen. No chemical blowing agents shall be used in the cell generation process.

Use seals manufactured with grooves  $\frac{1}{8}$ "  $\pm$  wide by  $\frac{1}{8}$ "  $\pm$  deep and spaced between  $\frac{1}{4}$ " and  $\frac{1}{2}$ " apart along the bond surface running the length of the joint. Use seals with a depth that meets the manufacturer's recommendation, but is not less than 70% of the uncompressed width. Provide a seal designed so that, when compressed, the center portion of the top does not extend upward above the original height of the seal by more than  $\frac{1}{4}$ ". Provide a seal that has a working range of 30% tension and 60% compression and meets the requirements given below.

TEST	TEST METHOD	REQUIREMENT
Tensile Strength	ASTM D3575, Suffix T	110 – 130 psi
Compression Set	ASTM D1056 Suffix B, 2 hr recovery	10% - 16%
Water Absorption	ASTM D3575	< 0.03 lb/ft <sup>2</sup>
Elongation at Break	ASTM D3575	180% - 210%
Tear Resistance	ASTM D624 (D3575, Suffix G)	14 – 20 pli
Density	ASTM D3575, Suffix W, Method A	1.8 – 2.2 lb/ft <sup>3</sup>
Toxicity	ISO-10993.5	Pass (not cytotoxic)

Have the top of the joint seal clearly shop marked. Inspect the joint seals upon receipt to ensure that the marks are clearly visible before installation.

#### **BONDING ADHESIVE**

Use a two-component, 100% solid, modified epoxy adhesive supplied by the joint seal manufacturer that meets the requirements given below.

TEST	TEST METHOD	REQUIREMENT
Tensile strength	ASTM D638	3,000 psi (min.)
Compressive strength	ASTM D695	7,000 psi (min.)
Hardness	Shore D Scale	75-85 psi
Water Absorption	ASTM D570	0.25% by weight max.
Elongation to Break	ASTM D638	5% (max.)
Bond Strength	ASTM C882	2,000 psi (min.)

Use an adhesive that is workable to 40°F. When installing in ambient air or surface temperatures below 40°F or for application on moist, difficult to dry concrete surfaces, use an adhesive specified by the manufacturer of the joint seal.

#### **SAWING THE JOINT**

The concrete at the face of the joint (elastomeric concrete, polyester polymer concrete, Portland cement concrete, etc.) shall have sufficient time to cure such that no damage can occur to the concrete prior to sawing to the final width and depth as specified in the plans.

When sawing the joint to receive the foam seal, always use a rigid guide to control the saw in the desired direction. To control the saw and to produce a straight line as indicated on the plans, anchor and positively connect a template or a track to the bridge deck. Do not saw the joint by visual means such as a chalk line. Fill the holes used for holding the template or track to the deck with an approved flowable, non-shrink, non-metallic grout.

Saw cut to the desired width and depth in one (1) or two (2) passes of the saw by placing and spacing two (2) metal blades on the saw shaft to the desired width for the joint opening.

The desired depth is the depth of the seal plus ¼” above the top of the seal plus approximately 1” below the bottom of the seal. An irregular bottom of sawed joint is permitted as indicated on the plans. Grind exposed corners on saw cut edges to a ¼” chamfer.

Saw cut a straight joint, centered over the formed opening and to the desired width specified in the plans. Prevent any chipping or damage to the sawed edges of the joint.

Remove any staining or deposited material resulting from sawing with a wet blade to the satisfaction of the Engineer.

#### **PREPARATION OF SAWED JOINT FOR SEAL INSTALLATION**

The elastomeric concrete or polyester polymer concrete at the joint shall cure a minimum of 24 hours prior to seal installation. Portland cement concrete at the joint shall cure following the special provisions.

After sawing the joint, the Engineer will thoroughly inspect the sawed joint opening for spalls, popouts, cracks, etc. All necessary repairs will be made by the Contractor prior to blast cleaning and installing the seal, at no cost to the Department.

Clean the joints by sandblasting with clean dry sand immediately before placing the bonding agent. Sandblast the joint opening to provide a firm, clean joint surface free of curing compound, loose material and any foreign matter. Sandblast the joint opening without causing pitting or uneven surfaces. The aggregate in the joint concrete may be exposed after sandblasting.

After blasting, either brush the surface with clean brushes made of hair, bristle, or fiber, blow the surface with compressed air, or vacuum the surface until all traces of blast products and abrasives are removed from the surface, pockets, and corners.

If nozzle blasting is used to clean the joint opening, use compressed air that does not contain detrimental amounts of water or oil.

Examine the blast-cleaned surface and remove any traces of oil, grease, or smudge deposited in the cleaning operations.

Bond the seal to the blast-cleaned surface on the same day the surface is blast cleaned.

#### **SEAL INSTALLATION**

Install the joint seal according to the manufacturer’s procedures and recommendations and as recommended below. Do not install the joint seal if the ambient air or surface temperature is below

45°F. Have a manufacturer's certified trained factory representative present during the installation of the first seal of the project.

Before installing the joint seal, check the uninstalled seal length to ensure the seal is the same length as the deck opening. When the joint seal requires splicing, use the heat welding method by placing the joint material ends against a Teflon heating iron of 425-475°F for 7 - 10 seconds, then pressing the ends together tightly. Do not test the welding until the material has completely cooled.

Begin installation by protecting the top edges of the concrete deck adjacent to the vertical walls of the joint as a means to minimize clean up. Stir each epoxy bonding agent component independently, using separate stirring rods for each component to prevent premature curing of the bonding agent. Pour the two (2) components, at the specified mixing ratio, into a clean mixing bucket. Mix the components with a low speed drill (400 rpm max.) until a uniform gray color is achieved without visible marbling. Apply bonding agent to both sides of the joint concrete, as well as both sides of the joint seal, making certain to fill completely the grooves with epoxy. With gloved hands, compress the joint seal and with the help of a blunt probe, push the seal into the joint opening until the seal is recessed approximately ¼" below the surface. When pushing down on the joint seal, apply pressure only in a downward direction. Do not push the joint seal into the joint opening at an angle that would stretch the material. Seals that are stretched during installation shall be removed and rejected. Once work on placing a seal begins, do not stop until it is completed. Clean the excess epoxy from the top of the joint seal immediately with a trowel. Do not use solvents or any cleaners to remove the excess epoxy from the top of the seal. Remove the protective cover at the joint edges and check for any excess epoxy on the surface. Remove excess epoxy with a trowel, the use of solvents or any cleaners will not be allowed.

The installed system shall be watertight and will be monitored until final inspection and approval.

(A) Watertight Integrity Test

- (1) Upon completion of each foam seal expansion joint, perform a water test on the top surface to detect any leakage. Cover the roadway section of the joint from curb to curb, or barrier rail to barrier rail, with water, either ponded or flowing, not less than 1 inch above the roadway surface at all points. Block sidewalk sections and secure an unnozzled water hose delivering approximately 1 gallon of water per minute to the inside face of the bridge railing, trained in a downward position about six (6) inches above the sidewalk, such that there is continuous flow of water across the sidewalk and down the curb face of the joint.
- (2) Maintain the ponding or flowing of water on the roadway and continuous flow across sidewalks and curbs for a period of five (5) hours. At the conclusion of the test, the underside of the joint is closely examined for leakage. The foam seal expansion joint is considered watertight if no obvious wetness is visible on the Engineer's finger after touching a number of underdeck areas. Damp concrete that does not impart wetness to the finger is not considered a sign of leakage.
- (3) If the joint system leaks, locate the place(s) of leakage and take any repair measures necessary to stop the leakage at no additional cost to the Department. Use repair measures recommended by the manufacturer and approved by the Engineer prior to beginning corrective work.

- (4) If measures to eliminate leakage are taken, perform a subsequent water integrity test subject to the same conditions as the original test. Subsequent tests carry the same responsibility as the original test and are performed at no additional cost to the Department.

Do not place pavement markings on top of foam joint seals.

#### **BASIS OF PAYMENT**

*Foam Joint Seals for Preservation* will be measured and paid for at the contract unit price bid per linear foot and will be full compensation for furnishing all material, labor, tools, and equipment necessary for installing these seals in place and accepted.

#### **Pay Item**

Foam Joint Seals for Preservation

#### **Pay Unit**

Linear Feet

#### **POURABLE SILICONE JOINT SEALANT**

**(SPECIAL)**

#### **SEALS**

Provide and install a low modulus silicone sealant (non-sag or self-leveling) and backer rod which conforms to the *Standard Specifications* (Subsections 1028-3 and 1028-4, respectively) and this special provision. Use silicone approved for use on joint openings as indicated on project plans and provide a seal with a working range of minimum 50% compression and extension. Silicone joint seal product shall be designated as approved for use on the NCDOT Approved Products List. If non-sag and self-leveling sealants are to be in contact with each other, they shall be from the same manufacturer and shall be compatible for such use.

#### **SAWING THE JOINT**

Joint concrete material or joint concrete header material shall have sufficient time to cure such that no damage can occur to the concrete prior to sawing to the final width and depth as specified in the plans.

When sawing the joint to receive the seal, always use a rigid guide to control the saw in the desired direction. To control the saw and to produce a straight line as indicated on the plans, anchor and positively connect a template or a track to the bridge deck. Do not saw the joint by visual means such as a chalk line. Fill the holes used for holding the template or track to the deck with an approved flowable, non-shrink, non-metallic grout.

Saw cut to the desired width and depth in one or two (2) passes of the saw by placing and spacing two (2) metal blades on the saw shaft to the desired width for the joint opening.

The desired depth is the depth of the seal plus ¼ ” above the top of the seal plus approximately 1” below the bottom of the seal. An irregular bottom of sawed joint is permitted as indicated on the plans. Grind exposed corners on saw cut edges to a ¼ ” chamfer.

Saw cut a straight joint, centered over the formed opening and to the desired width specified in the plans. Prevent any chipping or damage to the sawed edges of the joint.

Remove any staining or deposited material resulting from sawing with a wet blade to the satisfaction of the Engineer.

#### **PREPARATION OF FORMED OR SAWED JOINT FOR SEAL INSTALLATION**

Joint concrete material or joint concrete header material shall cure a minimum of 24 hours prior to seal installation.

After forming or sawing the joint, the Engineer will thoroughly inspect the joint opening for spalls, popouts, cracks, etc. All necessary repairs will be made by the Contractor prior to blast cleaning and installing the seal, at no cost to the Department.

Clean the joints by sandblasting the joint opening to provide a firm, clean joint surface free of curing compound, loose material, and any foreign matter. Sandblast the joint opening without causing pitting or uneven surfaces. The aggregate in the polyester polymer concrete may be exposed after sandblasting.

After blasting, either brush the surface with clean brushes made of hair, bristle, or fiber, blow the surface with compressed air, or vacuum the surface until all traces of blast products and abrasives are removed from the surface, pockets, and corners. If nozzle blasting is used to clean the joint opening, use compressed air that does not contain detrimental amounts of water or oil.

Examine the blast-cleaned surface and remove any traces of oil, grease, or smudge deposited in the cleaning operations.

Apply recommended primer in accordance with the manufacturer's recommendations. Uniformly coat the entire surface. Over application may affect adhesion. Allow to thoroughly dry before installing backer rod and sealant.

Install a circular backer rod that is a minimum 25 percent oversized into the joint approximately 1 in. below the surface. The backer rod shall be sized according to the manufacturer's recommendation for the size of the joint to be sealed as measured by the Contractor. If two (2) pieces must be joined, abut the two (2) ends and tape them together to prevent sealant run down. The backer rod may be installed by hand, but roller device shall be used to insure a consistent, uniform placement at the proper depth below the top surface.

Install the backer rod and silicone sealant in the blast-cleaned opening on the same day the surface is blast cleaned.

#### **SEAL INSTALLATION**

Install the silicone joint sealant(s) as indicated on the plans, in accordance with the manufacturer's procedures and recommendations, and as recommended below. Do not install the joint seal if the ambient air or surface temperature is below 45°F. Have a manufacturer's certified trained factory representative present during the installation of the first seal of the project, to provide guidance for the proper installation of the silicone joint sealant(s).

The sealant must be recessed a minimum ½ in. below the pavement surface to prevent traffic abrasion or snow plow damage.

After a joint has been sealed, remove excess joint sealer on the pavement or bridge deck concrete as soon as possible.

The installed system shall be watertight and will be monitored until final inspection and approval.

Do not place pavement markings on top of pourable joint seals.

**(B) Watertight Integrity Test**

- (1) Upon completion of each strip seal expansion joint, perform a water test on the top surface to detect any leakage. Cover the roadway section of the joint from curb to curb, or barrier rail to barrier rail, with water, either ponded or flowing, not less than 1 inch above the roadway surface at all points. Block sidewalk sections and secure an unnozzled water hose delivering approximately 1 gallon of water per minute to the inside face of the bridge railing, trained in a downward position about six (6) inches above the sidewalk, such that there is continuous flow of water across the sidewalk and down the curb face of the joint.
- (2) Maintain the ponding or flowing of water on the roadway and continuous flow across sidewalks and curbs for a period of five (5) hours. At the conclusion of the test, the underside of the joint is closely examined for leakage. The strip seal expansion joint is considered watertight if no obvious wetness is visible on the Engineer’s finger after touching a number of underdeck areas. Damp concrete that does not impart wetness to the finger is not considered a sign of leakage.
- (3) If the joint system leaks, locate the place(s) of leakage and take any repair measures necessary to stop the leakage at no additional cost to the Department. Use repair measures recommended by the manufacturer and approved by the Engineer prior to beginning corrective work.
- (4) If measures to eliminate leakage are taken, perform a subsequent water integrity test subject to the same conditions as the original test. Subsequent tests carry the same responsibility as the original test and are performed at no additional cost to the Department.

**BASIS OF PAYMENT**

*Pourable Silicone Joint Sealant* will be measured and paid for at the contract unit price bid per linear foot and will be full compensation for furnishing all material, including backer rod, labor, tools, and equipment necessary for installing these seals in place and accepted.

<b>Pay Item</b>	<b>Pay Unit</b>
Pourable Silicone Joint Sealant	Linear Feet

**EXPANSION JOINT SEALS FOR PRESERVATION**

**(SPECIAL)**

**GENERAL**

The work covered by this Special Provision consists of furnishing and installing the expansion joint seals as shown on the contract drawings. All materials, labor, equipment, and incidentals necessary for the proper installation of the expansion joint seals are included.

**MATERIAL**

Provide expansion joint seals capable of accommodating a total movement measured parallel to the centerline of the roadway as shown on plans.

Provide an elastomeric component for each expansion joint seal that is a continuous unit for the entire length of the joint. Do not field splice the elastomeric component. Only vulcanized shop splicing of the elastomeric component is permitted. The minimum length of an elastomeric component before shop splicing is 20 feet. However, one piece shorter than 20 feet is permitted. Provide an elastomeric component that is clearly shop marked to indicate the top side and joint location of the elastomeric component. On skewed bridges, or under unsymmetrical conditions, clearly mark the left side of the elastomeric component. Left is defined as being on the left when facing in the direction of increasing station. Inspect the seals upon receipt to ensure that the marks are clearly visible upon installation.

Make sure the convolution of the gland does not project above the top of the hold-down plates when the joint opening is in the most compressed condition. Use either elastic polychloroprene (neoprene) or ethyl propylene diene monomer (EPDM) for the elastomer that meets the following minimum properties:

	ASTM TEST METHOD	REQUIREMENTS
Hardness, Durometer - Shore A	D2240	60 ± 5, Neoprene (upward corrugated shape - fabric reinforced) 75 ± 5, EPDM and Neoprene (upward non-corrugated shape) 80 ± 5, EPDM (upward corrugated shape-fabric reinforced)
Tensile Strength	D412	1500 psi (min.)
Elongation at Break	D412	250% (min.)
Width of Gland in Relaxed Condition	N/A	10" ± 0.25"
Thickness of Upturned portion of gland	N/A	0.25" non-corrugated shape, -0.032" to +0.032"
Thickness of Upturned portion of gland	N/A	0.1875" corrugated shape, -0.032" to +0.032"
Thickness of Flat portion of gland	N/A	0.1563", -0.032" to +0.032"

For fabric reinforced glands, submit one unreinforced sample per lot number, up to 500 feet of Expansion Joint Seal, to the Engineer for testing.



Field splice hold-down plates only at crown points, at abrupt changes in the deck slab cross slope, and on lane lines. Splicing within travel lanes is not permitted and splicing on edge lines is not required. Field splice hold-down plates between the edge line and gutter upturn and where necessary for proper installation and alignment is permitted. Show all splice locations on the working drawings for approval. For the location of lane markings at the expansion joint seal, see the Structure plans. At the splice locations, locate the hold-down bolts three (3) inches from the end of the hold-down plate. At splice locations where changes in deck slab cross slope occur, cut the ends of hold-down plates parallel to the bridge centerline for skews less than 80° and greater than 100°.

Do not use welded shop splices in hold-down plates.

Replace hold-down bolts with new bolts that conform to ASTM F593 alloy 304 stainless steel. Replace washers with new washers that conform to ASTM F844 except they shall be made from alloy 304 stainless steel.

#### **REPLACING EXISTING JOINT SEAL**

If plans call for the replacement of existing joint seal, only, without the rebuilding of the joint with new headers, etc., completely remove existing hold-down plates, joint seal material, adhesive, or other debris and deleterious material in the joint.

Inspect the condition of the existing hold-down plates for cracks, deformations or other damage that the Engineer might determine necessitates replacement of a hold-down plate. Replacement plates shall be metalized and conform to AASHTO M270 Grade 36 steel or approved equal.

Place new expansion joint seal as indicated in this special provision.

#### **SHOP DRAWINGS**

Submit working drawings to the Engineer for review, comments, and acceptance. Show complete details drawn to scale and include:

##### **(A) For Replacing Existing Joint Seal**

- (1) The proposed template details including the makeup of the template.
- (2) The proposed chronology of installation including the sequence and direction of the removal and replacement of the existing gland.
- (3) The proposed method for removing the hold-down plate.

##### **(B) For Rebuilt Joint**

- (1) The proposed template details including the makeup of the template
- (2) The proposed method of holding the base angle assembly in place while concrete is cast around it.
- (3) The proposed procedure to correct for the effects of beam movement and rotation when setting width of joint opening.

- (4) The proposed chronology of installation including the sequence and direction of the concrete casting.
- (5) The details of cross connectors between base angles, such as steel bars with slots bolted to angles, to maintain evenness between the adjacent base angles while accommodating movement that occurs when concrete is cast. Indicate when bolts are loosened to allow movement.
- (6) The proposed method for removing the hold-down plate.
- (7) A section detail through the joint showing horizontal offset dimensions of the base angles from the centerline joint. This detail is required when the vertical face of the joint opening is not perpendicular to the roadway surface (e.g. when the roadway grade is significant).

Have someone other than the person who prepares the drawing check all detailed drawings and include the initials of both the drafter and checker on each sheet of the drawings. The Engineer returns unchecked drawings to the Contractor. Provide all completed drawings two (2) weeks in advance of the scheduled installation time for the expansion joint seal repair.

## **INSTALLATION**

### Expansion Joint Seal Repairs Under Staged Closures

For expansion joint seal repairs that are staged, perform Steps 1 through 4 for the initial stage for gland replacement:

- (1) Loosen the existing bolts and hold down plates and remove the existing gland. Remove the existing neoprene sealant and clean the existing base angle and hold-down plates of oil, grease, and other latents.
- (2) Lay the new gland on the base angle and field mark the new gland for the bolt holes. Holes in the new gland shall be punched  $\frac{7}{8}$ " in diameter with a circular hand punch.
- (3) In order to check for proper alignment, place the new gland and hold-down plates on the base angle. Do not apply new neoprene sealant. Bolt the hold-down plates to the base angle with new bolts and washers, but do not tighten. The engineer shall inspect the joint seal gland, plates, and bolts for proper alignment.
- (4) After inspection, remove the hold-down plates and new gland. Apply new neoprene sealant to the base angle in accordance with the "installation sketch" on the Standard Drawing for Expansion Joint Seal Details. Place new gland and hold-down plates on the base angle. Bolt the hold-down plates to the base angle assembly and torque the bolts to 88 ft-lbs with a torque wrench. Check the torque after three (3) hours and, if necessary, retighten to 88 ft-lbs. A final check shall be made at seven (7) days. Torque shall not be less than 80 ft-lbs after seven (7) days.

After completion of Steps 1 through 4, open to traffic the stage that has had the new gland installed and close to traffic the next adjacent stage requiring a new gland. Continue with Steps 1 through 4 for removal of existing gland and placement of a new expansion joint gland. Proceed similarly for

each successive stage. After completion of installation of the joint gland for all stages, traffic may be returned, temporarily, to all stages.

After completion of installation of the new gland for all stages, perform Step 5 for each closure stage:

- (5) After proper torqueing, clean the bolt hole recesses and the recess between the joint seal device and concrete, completely fill these recesses with new neoprene sealant.

Allow sealant applied during Step 5 to cure for a minimum of four (4) hours before allowing traffic on the bridge. Alternatively, and if the sealant has not cured sufficiently to prevent sealant from adhering to passing traffic, the Contractor may propose a method (broadcast sand or other) to prevent sealant from adhering to passing traffic.

Unless otherwise approved by the Engineer, Step 5 shall be completed within seven (7) days of installation of new gland.

The Engineer shall be notified of any existing damaged areas, depressions, spalls, cracks, or irregularities of curbs or decks adjacent to the expansion joint. If directed by the Engineer, submit a proposed method of repair and repair material specifications for approval. If not already included in the scope of work for the project, this work to repair existing damaged deck or irregularities will be considered extra work and will be paid under the applicable pay items.

If the Engineer deems any aspects of the expansion joint seals unacceptable, make necessary corrections at no additional cost to the Department.

## **INSPECTION**

### **(A) Watertight Integrity Test**

- (1) Upon completion of an expansion joint seal, perform a water test on the top surface to detect any leakage. Cover the roadway section of the joint from curb to curb, or barrier rail to barrier rail, with water, either ponded or flowing, not less than 1 inch above the roadway surface at all points. Block sidewalk sections and secure an unnozzled water hose delivering approximately 1 gallon of water per minute to the inside face of the bridge railing, trained in a downward position about six (6) inches above the sidewalks, such that there is continuous flow of water across the sidewalk and down the curb face of the joint.
- (2) Maintain the ponding or flowing of water on the roadway and continuous flow across sidewalks and curbs for a period of two (2) hours. At the conclusion of the test, the underside of the joint is closely examined for leakage. The expansion joint seal is considered watertight if no obvious wetness is visible on the Engineer's finger after touching a number of underdeck areas. Damp concrete that does not impart wetness to the finger is not a sign of leakage.
- (3) If the joint system leaks, locate the place(s) of leakage and take any repair measures necessary to stop the leakage at no additional cost to the Department. Use repair measures recommended by the manufacturer and approved by the Engineer prior to beginning corrective work.

- (4) If measures to eliminate leakage are taken, perform a subsequent water integrity test subject to the same conditions as the original test. Subsequent tests carry the same responsibility as the original test and are performed at no extra cost to the Department.

#### **BASIS OF PAYMENT**

*Expansion Joint Seals For Preservation* will be paid at the contract unit price per linear foot and payment will be full compensation for furnishing and installing all material, including any steel accessory plates for sidewalks, medians and rails, any replacement steel hold-down plates, labor, tools, and incidentals necessary for installing the expansion joint seal repair in place and including all materials, labor, tools and incidentals for performing the original watertight integrity test.

#### **Pay Item**

Expansion Joint Seals for Preservation

#### **Pay Unit**

Linear Feet

#### **EPOXY COATING AND DEBRIS REMOVAL**

**(SPECIAL)**

#### **GENERAL**

This work applies to all bents and end bents of all bridges throughout the project as noted in the plans. Pressure wash, clean and epoxy coat top of the all bent and end bent caps under open joints and at the expansion joints of steel girder spans after painting of all girders is concluded.

Debris removal from the top of bent caps shall be incidental to epoxy coating the top of bent caps.

Use a Type 4A flexible and moisture insensitive epoxy coating in accordance with Section 1081 of the *Standard Specifications*. Provide a Type 3 material certification in accordance with Article 106-3 showing the proposed epoxy meets Type 4A requirements.

#### **SURFACES**

Apply the epoxy protective coating to the top surface area, including chamfer area of bent caps under open joints and expansion joints of the steel girder spans, excluding areas under elastomeric bearings.

Thoroughly clean all dust, dirt, grease, oil, laitance and other objectionable material from the concrete surfaces to be coated. Air blast all surfaces immediately before applying the protective coating.

Use only cleaning agents preapproved by the Engineer.

#### **APPLICATION**

Apply epoxy protective coating only when the air temperature is at least 40°F and rising, but less than 95°F and the surface temperature of the area to be coated is at least 40°F. Remove any excess or free-standing water from the surfaces before applying the coating. Apply one coat of epoxy protective coating at a rate such that it covers between 100 and 200 sf/gal.

Under certain combinations of circumstances, the cured epoxy protective coating may develop an oily condition on the surface due to amine blush. This condition is not detrimental to the applied system.

Apply the coating so the entire designated surface of the concrete is covered and all pores are filled. To provide a uniform appearance, use the exact same material on all visible surfaces.

#### **BASIS OF PAYMENT**

*Epoxy Coating* will be measured and paid for by the contract unit price per square foot and shall be full compensation for furnishing all material, labor, tools and equipment necessary for cleaning and coating the tops of bent caps. Debris removal from the top of bent caps shall be incidental to epoxy coating the top of bent caps.

#### **Pay Item**

#### **Pay Unit**

Epoxy Coating

Square Feet

#### **CONCRETE FOR DECK REPAIR**

**(5-19-23)**

#### **DESCRIPTION**

This special provision addresses the material property requirements of high early strength structural concrete to be used for reconstruction of deck slab and, if necessary, bent diaphragms as noted in the plans.

#### **MATERIALS**

Furnish Department approved pre-packaged concrete or bulk concrete materials in a mix proportioned to satisfy provisions for Class AA Concrete detailed in Article 1000-5 of the *Standard Specifications* or as otherwise noted in this special provision. Concrete mix shall meet the following requirements:

<b>Physical Property</b>	<b>Threshold Limitation</b>	<b>Test Method</b>
Compressive Strength (at 3 hrs.)	4,500 psi (min.)	ASTM C39/C109
Slump	4 in. (min.) 7 in. (max.)	AASHTO T119
Water to Cement Ratio	0.450 (max.)	N/A
Modulus of Elasticity (at 28 days)	5,200 ksi (max.)	ASTM C469

Coefficient of Thermal Expansion (at 28 days)	4.5 x 10 <sup>-6</sup> in./in./°F (min.) 5.5 x 10 <sup>-6</sup> in./in./°F (max.)	AASHTO T336
Concrete Setting Times		ASTM C191
Initial	30 min. (max.)	
Final	40 min. (max)	

Concrete shall be suitable for placement on existing concrete substrate surfaces between 40°F (min.) and 100°F (max.).

Measurement for determination of concrete material compositions shall be in accordance with Article 1000-8 of the *Standard Specifications*.

Submit pre-packaged concrete mix contents or concrete mix design, including laboratory compressive strength data, for a minimum of six (6) 4-inch diameter by 8-inch cylinders at an age of three (3) hours and six (6) 4-in diameter by 8-inch cylinders at an age of 1 day to the Engineer for review. Include test results for the slump and air content of the laboratory mix. Perform tests in accordance with AASHTO T119 and T152.

Provide aggregates that are free from ice, frost and frozen particles when introduced into the mixer.

For equipment, proportioning and mixing of concrete compositions, see Article 1000-12 of the *Standard Specifications* and the Volumetric Mixer special provision. Prior to beginning any work, obtain approval for all equipment to be used for joint area preparation, mixing, placing, finishing, and curing the deck repair concrete.

### **Measurement and Payment**

No separate payment will be made for Concrete for Deck Repair. Furnishing and placing concrete for deck repair shall be incidental to applicable pay items.

## **VOLUMETRIC MIXER**

**(12-18-12)**

### **DESCRIPTION**

This provision addresses the requirements for batching deck repair concrete at the point of delivery using a Mobile High Performance Volume Mixer (MHPVM). Work shall be in accordance with the general requirements of Section 1000-12 of the *Standard Specifications* and as amended by these provisions.

### **MATERIALS**

Produce high early strength concrete with MHPVM equipment. Furnish project site storage facilities that will provide protection of materials in accordance with the *Standard Specifications* and all material suppliers' recommendations.

#### **EQUIPMENT**

MHPVM devices shall have prominently displayed stamped metal plate(s) from the Volumetric Mixers Manufacturers Bureau stating that the equipment conforms to the requirements of ASTM C685.

Hydraulic cement concrete shall be mixed at the point of delivery by a combination of materials and mixer unit conforming to the following:

- 1.) The unit shall be equipped with calibrated proportioning devices for each ingredient added to the concrete mix. The unit shall be equipped with a working recording meter that is visible at all times and furnishes a ticket printout with the calibrated measurement of the mix being produced. If at any time the mixer fails to discharge a uniform mix, production of concrete shall be suspended until such time that problems are corrected.
- 2.) Each unit shall have prominently displayed stamped metal plate(s) attached by the manufacturer on which the following are plainly marked: the gross volume of the transportation unit in terms of mixed concrete, the discharge speed and the mass calibrated constant of the machine in terms of volume.
- 3.) MHPVMs shall be calibrated by a Department approved testing agency in accordance with the manufacturer's recommendations at an interval of every 6 months or a maximum production of 2500 cubic yards, whichever comes first prior to use on the project. The yield shall be maintained within a tolerance of +/- 1% and verified using a minimum 2 cubic feet container every 500 cubic yards or a minimum of once per week.
- 4.) The three cubic feet initially discharged from the truck shall be discarded and not used for concrete placement. Acceptance of the concrete shall comply with the Standard Specifications except that the sample secured for acceptance testing will be taken after four cubic feet is discharged from the delivery vehicle. During discharge, the consistency as determined by ASTM C143 on representative samples taken from the mixer discharge at random intervals shall not vary by more than 1 inch. Acceptance tests shall be performed on each load. If test data demonstrates that acceptable consistency of concrete properties is being achieved, the Engineer may reduce testing requirements.
- 5.) MHPVM equipment shall be operated by a person who is a certified operator by the equipment manufacturer. Any equipment adjustments made during the on-site production of concrete shall be done under the direct on-site supervision of the producer's NCDOT Certified Concrete Batch Technician.

#### **UNIFORMITY AND ACCEPTANCE**

The contractor is responsible for providing a Certified Concrete Plant Technician during batching operations, and a Certified Concrete Field Technician during placing operations

#### **MEASUREMENT AND PAYMENT**

*Volumetric Mixer* will be paid for as lump sum and will be full compensation for furnishing the certified MHPVM devices and calibration of the equipment.

**Pay Item****Pay Unit**

Volumetric Mixer

Lump Sum

**EPOXY RESIN INJECTION****(08-08-22)****GENERAL**

For repairing cracks, an applicator certified by the manufacturer of epoxy injection system to be used is required to perform the epoxy resin injection. The Contractor shall submit documentation that indicates the firm, supervisor and the workmen have completed an instruction program in the methods of restoring concrete structures utilizing the epoxy injection process and have five (5) years of relative experience with a record of satisfactory performance on similar projects.

The Contractor furnishes all materials, tools, equipment, appliances, labor and supervision required when repairing cracks with the injection of an epoxy resin adhesive.

**SCOPE OF WORK**

Using Epoxy Resin Injection, repair all cracks 5 mils (125  $\mu\text{m}$ ) wide or greater in the interior bent columns and caps, in the ends of the girders, in the cantilevered portion of the ends of the girders, and in the cantilevered portion of the superstructure deck on the downstream side.

Repair the column cracks to the top of the footings. Make the underwater repairs when water surface elevation is low and the water is still. For underwater repairs, use manufacturer recommended materials.

Repair any crack, void, honeycomb or spall area unsuitable for repair by injection with epoxy mortar, or as otherwise approved by the Engineer.

**SUBMITTALS**

Prior to construction, the Contractor shall submit the following to the Engineer for review and approval:

- (A) Materials – Information detailing the materials and their properties, storage and handling requirements, and Material Safety Data Sheets. Material certifications and sampling shall be as required as per the NCDOT *Standard Specifications* Section 106.
- (B) Injection Procedures – Preparation and epoxy injection installation procedures, including written instructions from the manufacturer of the proportioning dispenser and the procedures recommended to monitor and assure its proportioning accuracy of the unit.
- (C) Contingencies – Proposed injection repair procedures in the event that during testing it is found that the injection installation procedure did not completely fill the cracks with epoxy.



(D) Qualifications – The resumes of the Contractor’s staff and/or the epoxy resin manufacturer’s Technical Representative that will be on site performing the epoxy injection. The resumes shall detail the installer's applicable certifications and epoxy injection installation experience.

(E) References – The names and telephone numbers of contact persons for recent (< 2years?) epoxy injection projects.

**COOPERATION**

Cooperate and coordinate with the Technical Representative of the epoxy resin manufacturer for satisfactory performance of the work.

Have the material manufacturer's Technical Representative present when the epoxy resin injection process begins and until the Engineer is assured that their service is no longer needed.

The expense of having this representative on the job is the Contractor’s responsibility at no additional cost to the Department .

**MATERIAL PROPERTIES**

Provide a two-component structural epoxy adhesive for injection into cracks or other voids. Provide modified epoxy resin (Component “A”) that conforms to the following requirements:

	Test Method	Specification Requirements
Viscosity @ 40 ± 3°F, cps	Brookfield RVT Spindle No. 4 @ 20 rpm	6,000 – 8,000
Viscosity @ 77 ± 3°F, cps	Brookfield RVT Spindle No. 2 @ 20 rpm	400 - 700
Epoxide Equivalent Weight	ASTM D1652	152 - 168
Ash Content, %	ASTM D482	1 max.

Provide the amine curing agent (Component “B”) used with the epoxy resin that meets the following requirements:

	Test Method	Specification Requirements
Viscosity @ 40 ± 3°F, cps	Brookfield RVT Spindle No. 2 @ 20 rpm	700 - 1400
Viscosity @ 77 ± 3°F, cps	Brookfield RVT Spindle No. 2 @ 20 rpm	105 - 240
Amine Value, mg KOH/g	ASTM D664*	490 - 560
Ash Content, %	ASTM D482	1 max.

	* Method modified to use perchloric acid in acetic acid.
--	--

Certify that the Uncured Adhesive, when mixed in the mix ratio that the material supplier specifies, has the following properties:

Pot Life (60 gram mass)

@ 77 ± 3°F - 15 minutes minimum

@ 100 ± 3°F - 5 minutes minimum

Certify that the Adhesive, when cured for seven (7) days at 77 ± 3°F unless otherwise specified, has the following properties:

	Test Method	Specification Requirements
Ultimate Tensile Strength	ASTM D638	7,000 psi (min.)
Tensile Elongation at Break	ASTM D638	4% max.
Flexural Strength	ASTM D790	10,000 psi (min.)
Flexural Modulus	ASTM D790	3.5 x 10 <sup>5</sup> psi
Compressive Yield Strength	ASTM D695	11,000 psi (min.)
Compressive Modulus	ASTM D695	2.0 - 3.5 x 10 <sup>5</sup> psi
Heat Deflection Temperature Cured 28 days @ 77 ± 3°F	ASTM D648*	125°F min. 135°F min.
Slant Shear Strength, 5,000 psi (34.5 MPa) compressive strength concrete  Cured 3 days @ 40°F wet concrete  Cured 7 days @ 40°F wet concrete  Cured 1 day @ 77°F dry concrete	AASHTO T237	   3,500 psi (min.)  4,000 psi (min.)  5,000 psi (min.)
* Cure test specimens so the peak exothermic temperature does not exceed 77°F.		

Use an epoxy bonding agent, as specified for epoxy mortar, as the surface seal (used to confine the epoxy resin during injection).

#### **EQUIPMENT FOR INJECTION**

Use portable positive displacement type pumps with interlock to provide positive ratio control of exact proportions of the two (2) components at the nozzle to meter and mix the two (2) injection adhesive components and inject the mixed adhesive into the crack. Use electric or air powered pumps that provide in-line metering and mixing.

Use injection equipment with automatic pressure control capable of discharging the mixed adhesive at any pre-set pressure up to  $200 \pm 5$  psi and equipped with a manual pressure control override.

Use equipment capable of maintaining the volume ratio for the injection adhesive as prescribed by the manufacturer. A tolerance of  $\pm 5\%$  by volume at any discharge pressure up to 200 psi is permitted.

Provide injection equipment with sensors on both the Component A and B reservoirs that automatically stop the machine when only one component is being pumped to the mixing head.

#### **PREPARATION**

Follow these steps prior to injecting the epoxy resin:

- (A) Remove all dirt, dust, grease, oil, efflorescence and other foreign matter detrimental to the bond of the epoxy injection surface seal system from the surfaces adjacent to the cracks or other areas of application. Acids and corrosives are not permitted.
- (B) Provide entry ports along the crack at intervals determined by the Contractor to ensure full penetration of the crack.
- (C) Apply surface seal material to the face of the crack between the entry ports. For through cracks, apply surface seal to both faces.
- (D) Allow enough time for the surface seal material to gain adequate strength before proceeding with the injection.
- (E) Perform an air pressure check of the surface seal to ensure the system is airtight prior to proceeding with the injection.

#### **EPOXY INJECTION**

Before epoxy adhesive injection occurs, the Contractor shall test discharge one pint of epoxy to calibrate the equipment and to demonstrate that the workmen and equipment are working properly.

Follow approved preparation and installation procedures submitted by the Contractor. It is the Contractor's responsibility to achieve full penetration of cracks being injected.

Perform epoxy adhesive injection continuously until cracks are completely filled. Pressure shall be maintained until complete refusal of material is achieved. Any stoppage of injection for more than 15 minutes shall result in the injection equipment being cleaned, at no additional cost to the Department, before resuming injection.

If port to port travel of epoxy adhesive is not indicated, or the surface seal and/or ports become dislodged, immediately stop the work and notify the Engineer.

### **TESTING**

The Contractor shall core 3" diameter by 6" deep samples of the cured epoxy to verify the cracks have been completely filled with epoxy. When coring, care shall be taken to avoid existing steel reinforcement, where possible. Injection will not proceed beyond the initial 50 feet until three (3) cores have been submitted to, and approved by, the Engineer. If the epoxy does not penetrate a minimum of 6" or the full depth of the crack, whichever is less, the repair will be rejected, and the contractor shall follow their proposed repair procedure that has been approved by the Engineer. The presence of the technical representative will be required when repairs begin.

The Engineer will take possession of the cores from the repaired concrete for compressive strength testing. If the failure plane is located at the repaired crack, a minimum compressive strength of 3,000 psi is required of these cores. The cost of coring is incidental to the pay item for epoxy injection. If the core fails, the contractor will be required to take corrective action before proceeding and another 50' test section will be required.

After the contractor demonstrates acceptable repairs, cores will be taken at a rate of one per 100 linear feet of repair until completion of the work or unacceptable cores are encountered.

### **FINISHING**

When cracks are completely filled, allow the epoxy adhesive to cure for sufficient time to allow the removal of the surface seal without any draining or runback of epoxy material from the cracks.

Fill all cored holes with Type 3 grout in accordance with Section 1003 of the *Standard Specifications*.

Remove the surface seal material and injection adhesive runs or spills from concrete surfaces.

Finish the face of the crack and all core holes flush to the adjacent concrete, removing any indentations or protrusions caused by the placement of entry ports or grout placement.

### **BASIS OF PAYMENT**

*Epoxy Resin Injection* will be paid at the contract unit price per linear foot. For full depth cracks, payment will be made for one side only. Such payment will be full compensation for all materials, tools, equipment, labor, coring and for all incidentals necessary to complete the work.

**Pay Item****Pay Unit**

Epoxy Resin Injection

Linear Foot

**SILANE DECK TREATMENT****(SPECIAL)****DESCRIPTION**

This work consists of preparation of concrete bridge deck, sidewalk and median island surfaces and the furnishing and application of alkylalkoxysilane (silane) penetrant sealers, with 100% solids, to seal bridge deck surfaces and cracks. Prepare the surface of the concrete deck and apply the silane bridge deck sealer in accordance with this special provision and as indicated on the plans, or as approved by the Engineer.

Work includes: bridge deck surface preparation, placement of silane deck sealer, and any incidentals necessary to complete the project, as specified or as indicated on the plans.

**SUBMITTALS**

Submit for approval the following requested items and any other relevant documents:

- (A) A safety data sheet (SDS) for each shipment of the silane materials.
- (B) Silane material information and manufacturer's written preparation and application instructions.
- (C) Certification from an independent testing laboratory that the materials meet the requirements of these provisions. Do not incorporate these materials into the project until the Engineer has accepted and approved the certification for the material.
- (D) The dates of manufacture of the silane materials, their lot numbers and date of shelf-life expiration for each lot number.
- (E) A table indicating the likely cure time, in minutes, to allow vehicular traffic on the silane-treated deck surface. Provide time for the allowable ambient temperature range, in increments of 10° F (6° C).
- (F) A work plan for each structure that includes estimated times for surface preparation and silane application.

**MATERIAL DELIVERY AND STORAGE**

Store at the site sufficient quantities of silane materials to perform the entire application.

Deliver materials in manufacturer's original, unopened, undamaged containers with identification labels intact. Ensure that each container is clearly marked by the manufacturer with the following information:

- (A) Manufacturer's name and address.
- (B) Product name.
- (C) Date of manufacture.
- (D) Expiration date.
- (E) Lot identification number.
- (F) Container serial number.

Provide the Engineer a certification from the manufacturer, confirming that the silane materials meet the requirements of this special provision. Do not incorporate these materials into the project until the Engineer has accepted and approved the certification for the material. Submit such certification for each lot of material delivered to the project. In each certification, identify the serial or lot numbers of the containers certified.

The Engineer may require samples from each lot or container of materials delivered to the project or from containers at the point of use. When samples are required, furnish samples in accordance with the Engineer's instructions.

Store silane materials in unopened containers in a clean, dry area between 40° F and 90° F. Store containers in a manner that prevents leakage or spillage.

#### **MANUFACTURER'S REPRESENTATIVE**

Provide a manufacturer's representative on site for the duration of the surface preparation and silane application work, to provide expert assistance on surface preparation, storage, mixing, application, clean-up, and disposal of materials.

#### **MATERIALS**

Provide silane from a single manufacturer, and provide silane that conforms to requirements indicated in Table 1, below.

**Table 1  
SILANE PROPERTIES**

<b>Property</b>	<b>Test Method</b>	<b>Requirement</b>
Silane Content		100%
VOC content	EPA method 24	Less than 350 g/l
Surface Appearance after Application		Unchanged
Flash Point	ASTM D3278	140° F, minimum
Resistance to Chloride Ion Penetration	AASHTO T259 and T260	Less than: 0.52 pounds/yd <sup>3</sup> (criteria of 1.5) at 1/2 inch level; 0.00 pounds/yd <sup>3</sup> (criteria of 0.75) at 1 inch level
Water absorption test	ASTM C 642	0.50% maximum/48 hours; 1.5% maximum/50 days
Scaling resistance	ASTM C 672	(non-air-entrained concrete) 0 rating "No Scaling" (100 cycles)
NCHRP 244		
Water weight gain	Series II - cube test	85% reduction, minimum
Absorbed chloride		87% reduction, minimum

Absorbed chloride	Series IV - Southern climate	95% reduction, minimum
-------------------	------------------------------	------------------------

### **SURFACE PREPARATION**

Prepare the surface of the concrete deck for application of the silane by shotblasting in order to remove all existing grease, slurry, oils, paint, dirt, striping, curing compound, rust, membrane, weak surface mortar, or any other contaminants that could interfere with the proper adhesion, penetration, and the curing of the silane material.

Prepare a final surface that adheres to the following requirements:

- (A) For areas to receive deck seal treatment, clean by shotblasting. Where approved by the Engineer, abrasive sandblasting may be used in areas that cannot be accessed by the shotblaster. Select the size of shot or sand, and travel speed of the equipment to provide a uniformly clean surface with a uniform profile. Remove striping to the maximum extent determined to be practical by the Engineer using up to three passes with shotblasting, sandblasting, or other approved equipment. Do not expose cleaned surfaces to vehicular traffic unless approved by the Engineer. If the deck becomes contaminated before placing the silane deck sealer, shotblast or abrasive sandblast the contaminated areas to the satisfaction of the Engineer, at no additional cost.
- (B) Prior to silane application, protect cracks on the concrete bridge deck from materials that can interfere with the penetration and the curing of the silane material. Just prior to placement of the silane, remove, by magnets and oil-free compressed air and vacuuming, any loose particles, such that no excess particles remain. The concrete deck shall be completely dry. Power washing will not be allowed.
- (C) The silane manufacturer may suggest cleaning and preparation methods other than those detailed by this special provision. The Engineer must approve such alternative methods prior to implementation.

### **SILANE APPLICATION**

#### **(A) Test Area**

- (1) Test a small area of the surface (minimum 5 ft. by 5 ft.) before general application to ensure desired performance results, aesthetics, and application rates and to verify application technique. Allow 5–7 days for the product to react fully before evaluating.
- (2) Application rates may vary depending on field conditions and the substrate to be treated.
- (3) Conduct at least one absorption test in the test area, using a Rilem Tube Test. Acceptable results are no loss of water in the Rilem tube over a period of 20 minutes. Adjust application to achieve required repellent performance.
- (4) The manufacturer's representative shall assist the Contractor in determining the application rates. Use test applications on actual surfaces to determine accurate application rates. Extremely porous surfaces may require two (2) coats of silane.
- (5) Do not begin production application of silane until Engineer has approved the test area, including approval of aesthetics, color, texture, and appearance.

#### **(B) Application**

Immediately before placing silane, all exposed surfaces shall be completely dry and blown clean with oil-free compressed air to remove any loose dust and debris. Apply silane as soon as practical after the exposed surfaces have been properly prepared and conditions are satisfactory:

- (1) Stir material thoroughly before and during application.
- (2) Apply silane with low-pressure spray or by flooding, followed by brooming or squeegeeing for even distribution, in accordance with manufacturer's instructions.
- (3) Maintain operating pressures in sprayers used for application of the silane sealer material sufficiently low so that atomization or misting of the material does not occur.
- (4) Begin the application of the silane at the lowest elevation and proceed upward, toward higher elevations, unless otherwise approved by the Engineer.
- (5) Apply even distribution of silane. Take care when applying the silane, so that running or ponding does not occur.
- (6) Apply silane in a single application to the concrete deck surface with enough material to saturate the surface. Remove excess material with a broom or squeegee and dispose of excess material appropriately. If a second coat is required, it should be applied "wet on wet" before first coat dries.
- (7) Application of sealant by spray methods will not be permitted when wind speeds are 20 mph or more, or if in the opinion of the Engineer, unsatisfactory results will be obtained. Other application methods or rescheduling will be required.
- (8) Avoid application with hand pump sprayers. For small areas of silane application, the use of hand pump sprayers must be approved by the Engineer.
- (9) Contractor shall protect from overspray all pedestrians, vehicles, plants and vegetation, and other areas not receiving silane application.
- (10) Allow product to penetrate the bridge deck and dry, as required by the manufacturer, prior to opening to traffic.

#### **LIMITATIONS OF OPERATIONS**

- (1) Prior to application of any silane sealer, cure concrete or concrete repairs for a minimum of 28 days or as required by the silane manufacturer.
- (2) Do not use silane material after the shelf life date.
- (3) Do not return unused material in opened containers to storage for later use. Either apply such material to appropriate areas on concrete deck surfaces or remove and appropriately dispose of it at offsite locations provided by the Contractor.
- (4) If expansion joints are not being replaced or have been replaced prior to shotblasting, they shall be protected from damage from the shotblasting operation. Deck drains and areas of curb or railing above the proposed surface shall be protected from the shotblasting operation.
- (5) Pick up and store all blast media and contaminants in a vacuum unit. Do not create dust during the blasting operation that will obstruct the view of motorists in adjacent roadways. Store, handle, and dispose of blast media and contaminants in accordance with all applicable local, state, and federal requirements.



- (6) Cover deck joint seal and elastomeric material, plug deck drain scuppers, seal cracks on underside of deck, and use other necessary protective measures to prevent leakage of silane below the concrete deck, to protect waterways, bridge components, pedestrians, vehicles, roadway, vegetation, and any other items or areas below or near the bridge.
- (7) Application of sealant by spray methods will not be permitted during windy conditions, if in the opinion of the Engineer, unsatisfactory results will be obtained. Other application methods or rescheduling will be required.
- (8) Avoid application with hand pump sprayers. For small areas of silane application, the use of hand pump sprayers might be allowed, but must be approved by the Engineer.
- (9) Protect traffic from rebound, dust, overspray, and construction activities. Provide appropriate shielding, as required and/or directed by the Engineer.
- (10) The Contractor shall provide suitable coverings (e.g. heavy-duty drop cloths) as needed to protect all exposed areas not to receive silane treatment, such as asphalt pavement, curbs, sidewalks, parapets, etc.
- (11) Clean and/or repair all damage or defacement resulting from Contractor's operations to the Engineer's satisfaction at no additional cost to the Department.
- (12) The equipment used for silane application must be clean of foreign materials and approved by the Engineer before use.
- (13) The surface to receive the treatment shall be dry for at least 48 hours before treatment and shall be free from sand, surface dust and dirt, oil, grease, chemical films, and other contaminants prior to application of the silane.
- (14) The surface, air, and material temperatures shall be between 40°F and 90°F during application.
- (15) Do not apply silane materials during cold, hot, or wet weather conditions or when adverse weather conditions are forecast within 12 hours of the completion of the silane application. Correct any coating damaged by rain or moisture by an additional application or as required by the silane manufacturer.
- (16) Protect prepared surfaces from precipitation and heavy dew during and after the application of the silane.
- (17) Conduct the work in a continuous operation, with the silane application as soon as practical following surface preparation.
- (18) Apply silane during the lowest temperature period of the day, typically between 1:00 a.m. and 9:00 a.m., when the cracks are open to the greatest extent.
- (19) Clean up, dispose of any surplus material, and restore any disturbed areas unless otherwise directed.
- (20) 100% Silane is a combustible liquid; take appropriate precautions during handling, storage, and operations. **KEEP AWAY FROM OPEN FLAME.**
- (21) Work crews should wear appropriate personal protection equipment and follow manufacturer's recommendations when applying silane. Refer to the SDS and all applicable local, state, and federal laws, and rules and regulations of authorities having jurisdiction over the project, for specific guidance for personal and environmental protection and safety requirements.

**MEASUREMENT AND PAYMENT**

*Shotblasting Bridge Deck* will be measured and paid for at the contract unit price per square yard and will be full compensation for the shotblasting and necessary sandblasting and handwork to prepare the entire concrete bridge deck, and removal and disposal of all waste material generated.

*Silane Deck Treatment* will be measured and paid for at the contract unit price per square yard and will be full compensation for bridge deck surface and crack preparation; for furnishing and applying the silane deck treatment; for protection of waterways, bridge, and other nearby surfaces, vehicles, and pedestrians; and for all labor, tools, and incidentals necessary to complete the work.

Payment will be made under:

<b>Pay Item</b>	<b>Pay Unit</b>
Shotblasting Bridge Deck	Square Yard
Silane Deck Treatment	Square Yard

**CONCRETE DECK REPAIR FOR SILANE DECK TREATMENT (SPECIAL)**

**GENERAL**

This special provision addresses concrete deck repairs prior to placing silane deck treatment. Work shall begin within 60 days of notification. After surface preparation, the Engineer sounds the deck using a chain drag or other acceptable means and marks areas to be repaired.

**MATERIALS**

Concrete deck repair material shall be epoxy-based material listed as a Type 2 epoxy resin system on the NCDOT Approved Product List (APL) and approved by the silane deck treatment manufacturer for use with the proposed silane deck treatment system. Concrete deck repair material shall attain a minimum compressive strength of 4,500 psi within 3 hours. Proportioning, aggregates, mixing, and curing of the epoxy-based repair material shall follow all manufacturer’s requirements.

Materials containing cement mortar may be acceptable; however, a 28 day curing period will be required before placing the silane deck treatment. The curing period may be adjusted if approved by the silane manufacturer and the Engineer. If repair materials containing cement mortar are proposed, they shall meet the following requirements:

Furnish Department approved pre-packaged concrete or bulk concrete materials in a mix proportioned to satisfy provisions for Class AA Concrete detailed in Article 1000-4 of the *Standard Specifications* or as otherwise noted in the Concrete for Deck Repair special provision.

**CLASS II SURFACE PREPARATION (PARTIAL DEPTH)**

Saw cut a perimeter surrounding the repair to a depth not less than 1 inch and remove all loose, unsound and contaminated material by chipping with hand tools to an average depth of approximately one-half the deck thickness, but no less 3/4” below the top mat of steel. Clean, repair, or replace rusted or loose reinforcing steel. Care shall be taken not to cut, stretch, or damage any exposed reinforcing steel. Thoroughly clean the newly exposed surface. Use a bonding agent in accordance with the manufacturer’s recommendations.

**PLACEMENT AND FINISHING**

Place concrete for deck repair at locations indicated on the plans that have been properly prepared as required in the subsection "Class II Surface Preparation (Partial Depth)" unless otherwise required by the repair material manufacturer or allowed by the Engineer, place, consolidate, finish, and cure concrete deck repair material in accordance with Section 420 of the *Standard Specifications*. For small deck areas (less than 16 sq. ft.) finish surface by tining to a depth of ¼" in a pattern similar to the existing grooving pattern.

**MEASUREMENT & PAYMENT**

*Concrete Deck Repair for Silane Deck Treatment* will be measured and paid for at the contract unit price per square feet for the appropriate areas repaired. The price shall include materials, labor, equipment, tools and any incidentals necessary to complete the work.

Payment will be made under:

<b>Pay Item</b>	<b>Pay Unit</b>
Concrete Deck Repair for Silane Deck Treatment	Square Feet

**SILANE BARRIER RAIL TREATMENT****(SPECIAL)****DESCRIPTION**

This work consists of preparation of bridge concrete barrier rail surfaces and the furnishing and application of alkylalkoxysilane (silane) penetrant sealers, with 100% solids, to seal bridge concrete barrier rail surfaces and cracks. Prepare the bridge concrete barrier rail surfaces and apply the silane bridge concrete barrier rail sealer in accordance with this special provision and as indicated on the plans, or as approved by the Engineer.

Work includes: bridge concrete barrier rail surface preparation, placement of silane penetrant sealer, appropriate removal and disposal of excess and waste material, and any incidentals necessary to complete the project, as specified or as indicated on the plans.

**SUBMITTALS**

Submit for approval the following requested items and any other relevant documents:

- (A) A safety data sheet (SDS) for each shipment of the silane materials.
- (B) Silane material information and manufacturer's written preparation and application instructions.
- (C) Certification from an independent testing laboratory that the materials meet the requirements of these provisions. Do not incorporate these materials into the project until the Engineer has accepted and approved the certification for the material.
- (D) The dates of manufacture of the silane materials, their lot numbers and date of shelf-life expiration for each lot number.

- (E) A table indicating the likely cure time, in minutes, to allow vehicular traffic on the bridge where the concrete barrier rail surface has been treated. Provide time for the allowable ambient temperature range, in increments of 10° F.
- (F) A work plan for each structure that includes estimated times for surface preparation and silane application.

#### **MATERIAL DELIVERY AND STORAGE**

Store at the site sufficient quantities of silane materials to perform the entire application.

Deliver materials in manufacturer's original, unopened, undamaged containers with identification labels intact. Ensure that each container is clearly marked by the manufacturer with the following information:

- (A) Manufacturer's name and address.  
 (B) Product name.  
 (C) Date of manufacture.  
 (D) Expiration date.  
 (E) Lot identification number.  
 (F) Container serial number.

Provide the Engineer a certification from the manufacturer, confirming that the silane materials meet the requirements of this special provision. Do not incorporate these materials into the project until the Engineer has accepted and approved the certification for the material. Submit such certification for each lot of material delivered to the project. In each certification, identify the serial or lot numbers of the containers certified.

The Engineer may require samples from each lot or container of materials delivered to the project or from containers at the point of use. When samples are required, furnish samples in accordance with the Engineer's instructions.

Store silane materials in unopened containers in a clean, dry area between 40° F and 90° F. Store containers in a manner that prevents leakage or spillage.

#### **MANUFACTURER'S REPRESENTATIVE**

Provide a manufacturer's representative on site for the duration of the surface preparation and silane application work, to provide expert assistance on surface preparation, storage, mixing, application, clean-up, and disposal of materials.

#### **MATERIALS**

Provide silane from a single manufacturer, and provide silane that conforms to requirements indicated in Table 1, below.

**Table 1  
SILANE PROPERTIES**

<b>Property</b>	<b>Test Method</b>	<b>Requirement</b>
Silane Content		100%
VOC content	EPA method 24	Less than 350 g/l
Surface Appearance after Application		Unchanged

Flash Point	ASTM D3278	140° F, minimum
Resistance to Chloride Ion Penetration	AASHTO T259 and T260	Less than: 0.52 pounds/yd <sup>3</sup> (criteria of 1.5) at 1/2 inch level; 0.00 pounds/yd <sup>3</sup> (criteria of 0.75) at 1 inch level
Water absorption test	ASTM C 642	0.50% maximum/48 hours; 1.5% maximum/50 days
Scaling resistance	ASTM C 672	(non-air-entrained concrete) 0 rating “No Scaling” (100 cycles)
NCHRP 244		
Water weight gain	Series II - cube test	85% reduction, minimum
Absorbed chloride		87% reduction, minimum
Absorbed chloride	Series IV - Southern climate	95% reduction, minimum

#### **SURFACE PREPARATION**

Prepare the bridge concrete barrier rail surfaces for application of the silane in order to remove all existing grease, slurry, oils, paint, dirt, striping, curing compound, rust, membrane, weak surface mortar, or any other contaminants that could interfere with the proper adhesion, penetration, and the curing of the silane material.

Prepare a final surface that adheres to the following requirements:

- (A) For areas to receive silane treatment, clean by sandblasting or shotblasting. Select the size of shot or sand, and travel speed of the equipment to provide a uniformly clean surface with a uniform profile. Do not expose cleaned surfaces to vehicular traffic unless approved by the Engineer. If the bridge concrete barrier rail surfaces become contaminated before placing the silane treatment, shotblast or abrasive sandblast the contaminated areas to the satisfaction of the Engineer, at no additional cost.
- (B) Power washing of the bridge concrete barrier rail may be allowed as approved by the Engineer, but the concrete barrier shall be allowed to dry a minimum of 48 hours prior to application of the silane treatment.
- (C) Prior to silane application, protect cracks on the bridge concrete barrier rail from materials that can interfere with the penetration and the curing of the silane material. Just prior to placement of the silane, remove, by magnets and oil-free compressed air and vacuuming, any loose particles, such that no excess particles remain.
- (D) Prior to silane application, the bridge concrete barrier rail shall be completely dry.
- (E) The silane manufacturer may suggest cleaning and preparation methods other than those detailed by this special provision. The Engineer must approve such alternative methods prior to implementation.

#### **SILANE APPLICATION**

(A) Test Area

- (1) Test a small area of the surface (minimum 2 ft. by 2 ft.) before general application to ensure desired performance results, aesthetics, and application rates and to verify application technique. Allow 5–7 days for the product to react fully before evaluating.
- (2) Application rates may vary depending on field conditions and the substrate to be treated.
- (3) Conduct at least one absorption test in the test area, using a Rilem Tube Test. Acceptable results are no loss of water in the Rilem tube over a period of 20 minutes. Adjust application to achieve required repellent performance.
- (4) The manufacturer's representative shall assist the Contractor in determining the application rates. Use test applications on actual surfaces to determine accurate application rates. Extremely porous surfaces may require two (2) coats of silane.
- (5) Do not begin production application of silane until Engineer has approved the test area, including approval of aesthetics, color, texture, and appearance.

(B) Application

Immediately before placing silane, all exposed surfaces shall be completely dry and blown clean with oil-free compressed air to remove any loose dust and debris. Apply silane as soon as practical after the exposed surfaces have been properly prepared and conditions are satisfactory:

- (1) Stir material thoroughly before and during application.
- (2) Apply silane using low-pressure pumping equipment with a wet fan type spray nozzle. Rollers with a 1" nap or brushes are permitted. On vertical surfaces, apply the silane in a flooding application from the bottom upward, in accordance with manufacturer's instructions.
- (3) Maintain operating pressures in sprayers used for application of the silane sealer material sufficiently low, so that atomization or misting of the material does not occur.
- (4) Apply even distribution of silane. Take care when applying the silane, so that running or ponding does not occur.
- (5) Apply silane in a single application to the barrier rail surface with enough material to saturate the surface. Remove excess material with a roller or brush and dispose of excess material appropriately. If a second coat is required, it should be applied "wet on wet" before first coat dries.
- (6) Application of sealant by spray methods will not be permitted when wind speeds are 20 mph or more, or if in the opinion of the Engineer, unsatisfactory results will be obtained. Other application methods or rescheduling will be required.
- (7) Avoid application with hand pump sprayers. For small areas of silane application, the use of hand pump sprayers must be approved by the Engineer.
- (8) Contractor shall protect from overspray all pedestrians, vehicles, plants and vegetation, and other areas not receiving silane application. Damages that occur due to overspray shall be the responsibility of the Contractor.

- (9) Allow product to penetrate the bridge concrete barrier rail and dry, as required by the manufacturer, prior to opening to traffic.

#### **LIMITATIONS OF OPERATIONS**

- (1) Prior to application of any silane sealer, cure concrete or concrete repairs for a minimum of 28 days or as required by the silane manufacturer.
- (2) Do not use silane material after the shelf life date.
- (3) Do not return unused material in opened containers to storage for later use. Either apply such material to appropriate areas on barrier rail surfaces or remove and appropriately dispose of it at offsite locations provided by the Contractor.
- (4) Pick up and store all blast media and contaminants in a vacuum unit. Do not create dust during the blasting operation that will obstruct the view of motorists in roadways adjacent, above, below, or surrounding the silane treatment area. Store, handle, and dispose of blast media and contaminants in accordance with all applicable local, state, and federal requirements.
- (5) Cover deck joint seal and elastomeric material, plug deck drain scuppers, seal cracks on underside of deck, and use other necessary protective measures to prevent leakage of silane below the concrete deck and beyond the concrete barrier rail, to protect waterways, bridge components, pedestrians, vehicles, roadway, vegetation, and any other items or areas below or near the bridge.
- (6) Application of sealant by spray methods will not be permitted during windy conditions, if in the opinion of the Engineer, unsatisfactory results will be obtained. Other application methods or rescheduling will be required.
- (7) Avoid application with hand pump sprayers. For small areas of silane application, the use of hand pump sprayers might be allowed, but must be approved by the Engineer.
- (8) Protect traffic from rebound, dust, overspray, and construction activities. Provide appropriate shielding, as required and/or directed by the Engineer. Damages that occur due to the Contractor's operations shall be the responsibility of the Contractor.
- (9) The Contractor shall provide suitable coverings (e.g. heavy-duty drop cloths) as needed to protect all exposed areas not to receive surface preparation and silane treatment.
- (10) Clean and/or repair all damage or defacement resulting from Contractor's operations to the Engineer's satisfaction at no additional cost to the Department.
- (11) The equipment used for silane application must be clean of foreign materials and approved by the Engineer before use.
- (12) The surface to receive the treatment shall be dry for at least 48 hours before treatment and shall be free from sand, surface dust and dirt, oil, grease, chemical films, and other contaminants prior to application of the silane.
- (13) The surface, air, and material temperatures shall be between 40°F and 90°F during application.
- (14) Do not apply silane materials during cold, hot, or wet weather conditions or when adverse weather conditions are forecasted within 12 hours of the completion of the silane application. Correct any coating damaged by rain or moisture by an additional application or as required by the silane manufacturer.

- (15) Protect prepared surfaces from precipitation and heavy dew during and after the application of the silane.
- (16) Conduct the work in a continuous operation, with the silane application as soon as practical following surface preparation.
- (17) Apply silane during the lowest temperature period of the day, typically between 1:00 a.m. and 9:00 a.m., when the cracks are open to the greatest extent.
- (18) Clean up, dispose of any surplus material, and restore any disturbed areas unless otherwise directed.
- (19) 100% Silane is a combustible liquid; take appropriate precautions during handling, storage, and operations. KEEP AWAY FROM OPEN FLAME.
- (20) Work crews should wear appropriate personal protection equipment and follow manufacturer's recommendations when applying silane. Refer to the SDS and all applicable local, state, and federal laws, and rules and regulations of authorities having jurisdiction over the project, for specific guidance for personal and environmental protection and safety requirements.

**MEASUREMENT AND PAYMENT**

*Surface Preparation for Concrete Barrier Rail* will be measured and paid for at the contract unit price per square foot and will be full compensation for the shotblasting, sandblasting, or other necessary surface preparation and handwork to prepare the entire bridge concrete barrier rail and removal and disposal of all blast media and waste material generated.

*Silane Barrier Rail Treatment* will be measured and paid for at the contract unit price per square foot and will be full compensation for bridge concrete barrier rail and crack preparation; for furnishing and applying the silane barrier rail treatment; removal and disposal of excess and waste material generated; for protection of waterways, bridge, and other nearby surfaces, vehicles, and pedestrians; and for all labor, tools, and incidentals necessary to complete the work.

Payment will be made under:

<b>Pay Item</b>	<b>Pay Unit</b>
Surface Preparation for Concrete Barrier	Square Foot
Silane Barrier Rail Treatment	Square Foot

**EPOXY COATING CONCRETE GIRDER ENDS**

**(SPECIAL)**

**GENERAL**

This work applies to the end of concrete girders, as noted in the plans. Pressure wash, clean, and epoxy coat the end face, both side faces, and bottom face of concrete girders. Area for surface preparation and epoxy coating shall be considered the full height and width of the end face, the full height of the



side faces, the full width of the bottom face of the girders and shall extend to 2'-0" from the end of the girders.

Use a Type 4A flexible and moisture insensitive epoxy coating in accordance with Section 1081 of the *Standard Specifications*. Provide a Type 3 material certification in accordance with Article 106-3 showing the proposed epoxy meets Type 4A requirements.

#### **SURFACE PREPARATION**

If there is deterioration of the concrete girder end to be epoxy coated, the girder end shall be repaired following the applicable special provision for repair. Provide surface preparation, placement, and finishing of the repair area, following the applicable special provision for repair, before applying the protective epoxy coating. Follow epoxy coating manufacturer recommendations for curing time of repair materials, prior to application of epoxy coating.

If steel strands or reinforcement are present and will remain exposed at the concrete girder end faces, they shall be cleaned of loose paint rust, scale, dirt, oil, grease, and other detrimental substances by hand cleaning or power tool cleaning following Subarticle 442-7 (B) of the *Standard Specifications*.

Thoroughly clean all dust, dirt, grease, oil, laitance, and other objectionable material from the concrete surfaces to be coated.

Use only cleaning agents preapproved by the Engineer.

Air blast all surfaces immediately before applying the protective coating.

#### **APPLICATION**

Apply the epoxy protective coating to end face, both side faces, and the bottom face of concrete girders, excluding areas under elastomeric bearings. The epoxy protective coating shall be applied to the full height and width of the end face, the full height of the side faces, the full width of the bottom face of the girders and shall extend to 2'-0" from the end of the girders. Epoxy coating shall be applied to the prepared surfaces of any steel strands or reinforcement that will remain exposed.

Apply epoxy protective coating only when the air temperature is at least 40°F and rising, but less than 95°F and the surface temperature of the area to be coated is at least 40°F. Remove any excess water from the surfaces before applying the coating. Apply one coat of epoxy protective coating at a rate such that it covers between 100 and 200 sf/gal.

Under certain combinations of circumstances, the cured epoxy protective coating may develop an oily condition on the surface due to amine blush. This condition is not detrimental to the applied system.

Apply the coating so the entire designated surface of the concrete is covered and all pores are filled. To provide a uniform appearance, use the exact same material on all visible surfaces.

**BASIS OF PAYMENT**

*Epoxy Coating Concrete Girder Ends* will be measured and paid for by the contract unit price per square foot and shall be full compensation for furnishing all material, labor, tools and equipment necessary for cleaning and coating the concrete girder ends.

<b>Pay Item</b>	<b>Pay Unit</b>
Epoxy Coating Concrete Girder Ends	Square Feet

**BRIDGE JOINT DEMOLITION****(SPECIAL)****DESCRIPTION**

This special provision addresses the removal of existing joint material and adjacent concrete headers to facilitate the installation of new elastomeric concrete headers and bridge joint seals at the locations noted in the contract plans.

**EQUIPMENT**

Use the following surface preparation equipment:

- (A) Sawing equipment capable of sawing concrete to a specified depth.
- (B) Power driven hand tools for removal of concrete are required that meet the following requirements:
- (C) Pneumatic hammers weighing a nominal 15 lbs. (7 kg) or less
- (D) Pneumatic hammer chisel-type bits that do not exceed the diameter of the shaft in width.
- (E) Hand tools such as hammers and chisels for removal of final particles of concrete.

**REMOVAL AND PREPARATION**

Prior to any construction, take the necessary precautions to ensure debris from joint construction is not allowed to fall below the bridge deck.

Remove existing joint material by methods approved by the Engineer. Provide a 1" deep saw cut around the perimeter of areas noted for bridge deck removal.

Remove by chipping with hand tools elastomeric concrete headers adjacent to the joint to the limits shown on the contract plans. Use a small chipping hammer (15 lb. class) to prepare the edges of the repair area to limit micro fractures. In addition, all loose and unsound concrete shall be removed.

In overhangs, removing concrete areas greater than 0.60 ft<sup>2</sup>/ft length of bridge will require overhang support. Submit the overhang support method to the Engineer for approval.

Care shall be taken not to cut, stretch, or damage any exposed reinforcing steel. Dispose of the removed concrete.

If the condition of the concrete is such that deep spalls or sheer faces result, notify the Engineer for the proper course of action.

Clean, repair or replace rusted or loose reinforcing steel. Thoroughly clean the newly exposed surface to be free of all grease, oil, curing compounds, acids, dirt, or loose debris.

**MEASUREMENT AND PAYMENT**

*Bridge Joint Demolition* will be measured and paid for at the contract unit price bid per square foot and will be full compensation for removal, containment and disposal of existing joint material and concrete and shall include the cost of labor, tools, equipment and incidentals necessary to complete the work.

<b>Pay Item</b>	<b>Pay Unit</b>
Bridge Joint Demolition	Square Feet

**SLOPE PROTECTION VOID FILLING**

**(SPECIAL)**

**DESCRIPTION**

The Contractor shall use a High-Density Polyurethane Foam for slope protection void filling as shown in the plans, or as directed by the Engineer.

All existing slope protection shown on the plans, or as directed by the Engineer, shall be moved as needed and replaced after void filling is completed.

Construct new concrete slope protection in accordance with Section 462 of the Standard Specifications. The concrete thickness of the new slope protection shall match the thickness of the existing slope protection, no additional measurement will be made for thicknesses over 4". Construct the new slope protection to provide a smooth transition between existing slope protection sections with no vertical offsets.

**MATERIALS**

The medium used shall be blown, high density, hydrophobic polyurethane. The high density, closed cell, polyurethane system shall exhibit the following characteristics and physical properties:

Density, Lbs/Ft ASTM 1622	Compressive Strength ASTM 1621
3.0	40 psi.
3.5	50 psi.
4.0	60 psi.
6.0	110 psi.

The polyurethane foam system will have a free rise density of 3.0 – 4.2 lb/ft, with a minimum compressive strength of 40 psi. The expansion of the polyurethane foam under pressure increases the

foam density above the original free rise density value. The compressive strength is a function of density of the tested material; therefore the foam produced during the lifting process will normally have a higher compressive strength than foam produced without restriction (free rise).

#### **EQUIPMENT**

A list of lifting and undersealing equipment shall be submitted to the Engineer prior to commencement of the work for review. The minimum list of equipment required shall be as listed below. The listing is a minimum and shall not preclude the use of additional equipment.

- A pneumatic drill and an electric drill capable of drilling 5/8" to 3/4" dia. holes.
- A truck-mounted pumping unit capable of injecting the high density polyurethane formulation below the concrete slab or asphalt pavement. This pumping unit will be capable of controlling the rate of rise of the pavement.
- Stringlines or dial indicators may be periodically used to measure the rate of lift.

#### **CONSTRUCTION**

Void filling shall be in areas as indicated on the plans and as directed by the Engineer.

The Contractor shall move any existing rip rap (exact location and spacing to be determined in the field) to determine the extent of the voids under the cap to be filled. The expanding High Density Polyurethane Foam material shall be injected into the voids under the existing end bent caps.

It will be the Contractor's responsibility to control these operations to make sure rising of the end bent caps does not occur. The Contractor shall be responsible for any blowouts or lifting which may result from the process and shall repair the damaged area to the satisfaction of the Engineer without additional cost.

The High Density Polyurethane Foam shall reach 90% of the full compressive strength in 15 minutes after injection.

Injection holes shall be sealed with a non-expansive cementitious grout once leveling is complete.

#### **BASIS OF PAYMENT**

*Slope Protection Void Filling* will be measured and paid for at the pound contract bid price and will be measurement verified by the following Double Verification methods.

- A conversion from pump counters to pounds will be provided with a manufacturer's certification of the accurate conversion factor.
- A visual measurement conversion on the actual totes/barrels of pounds per inches pumped.

The quantity of material to be paid for shall be the actual quantity of High-Density Polyurethane Foam used to satisfactorily complete the work. Such price and payment shall be full compensation for furnishing and injecting the material, labor, tools, equipment, removal and disposal of all debris, and incidentals necessary to complete the work. Moving and replacing any existing material and

compaction of that material to correct grade transitions between existing slope protection, shall be considered incidental to the pay item

Payment will be made under:

<b>Pay Item</b>	<b>Pay Unit</b>
Slope Protection Void Filling	Pounds

### **DIAMOND GRINDING CONCRETE APPROACH SLABS**

**(SPECIAL)**

#### **DESCRIPTION**

This work consists of diamond grinding concrete approach slabs to provide a smooth transition from the roadway pavement to the elevation of the existing bridge deck. Perform the work covered by this provision including but not limited to diamond grinding and regrinding concrete approach slabs to meet final surface acceptable smoothness requirements detailed in Article 710-7, selecting diamond tipped saw blades and configuration of cutting head; containment and continual removal of residual slurry from approach slabs and disposal; furnishing all labor, materials, supplies, tools, equipment and incidentals as necessary. Perform this work at locations indicated in the plans or as directed by the Engineer.

Prior to beginning any diamond grinding operations, schedule a pre-grind meeting with grinding subcontractor, Division Construction Engineer, Project Engineer, Area Bridge Maintenance Engineer, representatives from the Roadside Environmental Unit and the Materials and Tests Unit.

#### **EQUIPMENT**

Use equipment with diamond tipped saw blades gang mounted on a power-driven self-propelled machine with a minimum wheelbase length of 15 feet that is specifically designed to smooth and texture Portland Cement Concrete pavement. Utilize equipment that does not cause ravels; aggregate fracture; spalls or disturbance to the longitudinal or transverse joints; or damage and/or strain to the underlying surface of the pavement. Should any of the above problems occur immediately suspend operations.

Provide a minimum 3 feet wide grinding head with 50 to 60 evenly spaced grooves per foot. Prior to designing the grinding head, evaluate the aggregate hardness of the concrete pavement and select the appropriate diamond size, diamond concentration and bond hardness for the individual saw blades.

Provide vacuuming equipment to continuously remove slurry residue and excess water from the pavement as part of the grinding operation. Do not allow the slurry material to flow into a travel lane occupied by traffic or into any drainage facility.

#### **METHOD OF CONSTRUCTION**

Grind the pavement surface to a uniform appearance with a high skid resistant longitudinal corduroy type texture.

Begin and end diamond grinding at lines normal to the pavement centerline. Grind only in the longitudinal direction. All grooves and adjacent passes shall be parallel to each other with no variation. Completely lap adjacent passes with no unground surface remaining between passes and no overlap of more than 1½ inches. Adjacent passes shall be within 1/8 inch of the same height as measured with a 3 foot straightedge. Maintain positive cross-slope drainage for the duration of the grinding operation.

Grind all travel lanes to include auxiliary lanes, ramps and loops with not less than 98 percent of the specified surface being textured by grinding. Grinding of the bridge decks and concrete shoulders will not be required. Remove a minimum 0.0625 inches at all locations except dips. Extra grinding to eliminate minor depressions is not required. It is anticipated that extra grinding will be required on the high side of existing faults in the pavement. There shall be no ridge between lanes. In a separate operation, transition the grinding of any remaining ridges greater than 1/8 inch in height on the outside edge next to the shoulder or at a tie to an existing facility to the satisfaction of the Engineer.

Final surface testing is not required on this project in accordance with Article 710-7 of the *2018 Standard Specifications*.

#### **DISPOSAL OF RESIDUAL SLURRY**

Diamond grinding slurry disposal shall be in accordance with the Statewide Permit for Land Application of Diamond Grinding Slurry (DGS), Permit No. WQ0035749 dated June 3, 2014. Submit a slurry disposal plan to the Engineer detailing method of handling and disposing of slurry from the diamond grinding operation a minimum of 60 days prior to beginning the diamond grinding operation. Engineer shall review the slurry disposal plan. Plan must be accepted prior to beginning the diamond grinding operation.

Disposal options are:

- (A) Land apply slurry directly from diamond grinding machine within the DOT right-of-way in the median, shoulders and slopes.
- (B) Collect, contain, haul, and land apply slurry within DOT right-of-way as directed by the Engineer and a representative from the Roadside Environmental Unit. Contractor shall disperse slurry through an operation that spreads slurry within allowable agronomic rates in an interchange or designated area.

If the above options for disposal of slurry do not qualify as acceptable methods as determined by the Department, then the Contractor will be compensated under Article 104-7 for any other disposal methods required by the Department.

To prevent the migration of any direct discharge from the diamond grinding machine or land applied DGS from entering a drainage inlet or structure, the contractor shall install wattles and silt fence at the direction of the Engineer. Silt Fence shall be installed in accordance with Section 1605 of the NCDOT *2018 Standard Specifications*.

For more detailed information, see the Environmental Permits and Guidelines section under Environmental resources on the NC Connect website for the DG permit and guidelines at the following link. (NCID access required.)

<https://connect.ncdot.gov/resources/Environmental/Environmental%20Permits%20and%20Guidelines/Forms/AllItems.aspx>

## **MEASUREMENT AND PAYMENT**

The quantity of *Diamond Grinding Concrete Approach Slab* to be paid for will be the actual number of square yards of concrete approach slab which has been satisfactorily diamond ground, measured along the final top surface of the pavement. No separate payment will be made for any overlapping, regrinding, or for extra grinding on the high side of existing faults.

Payment will be full compensation for the work, including but is not limited to grinding, containment and disposal of slurry, final surface testing, furnishing all materials, equipment, labor and all incidentals necessary to satisfactorily complete the work.

<b>Pay Item</b>	<b>Pay Unit</b>
Diamond Grinding Concrete Approach Slab	Square Yard

## **SAW CUTTING CONCRETE BARRIER RAIL**

**(SPECIAL)**

### **DESCRIPTION**

This work consists of saw cutting and removing sections the concrete barrier rail from the structure in accordance with the limits, depth and details shown on the plans, described herein and as established by the Engineer. This work also includes removing and disposing of all loose debris.

Any portion of the structure that is damaged from construction operations shall be repaired to the Engineer's satisfaction, at no extra cost to the Department.

### **EQUIPMENT**

Use the following surface preparation equipment:

- (A) Sawing equipment capable of sawing concrete to the depth of the barrier rail width.
- (B) Power driven hand tools for removal of concrete are required that meet the following requirements:
- (C) Pneumatic hammers weighing a nominal 15 lbs. (7 kg) or less

(D) Pneumatic hammer chisel-type bits that do not exceed the diameter of the shaft in width.

(E) Hand tools such as hammers and chisels for removal of final particles of concrete.

**REMOVAL AND PREPARATION**

Prior to any construction, take the necessary precautions to ensure debris from construction is not allowed to fall below the bridge deck.

Remove existing barrier rail material by methods approved by the Engineer. Provide a full deep saw cut at areas noted for removal.

Remove by full depth saw cutting adjacent to the joint to the limits shown on the contract plans. In addition, all loose and unsound concrete shall be removed.

Dispose of the removed concrete.

Saw cut 3/4" chamfers on all exposed faces of barrier rails newly cut edges.

If the condition of the concrete is such that deep spalls or sheer faces result, notify the Engineer for the proper course of action.

Thoroughly clean any exposed reinforcing steel surfaces to be free of all grease, oil, curing compounds, acids, dirt, or loose debris and coat with an approved epoxy coating.

**MEASUREMENT AND PAYMENT**

*Saw Cutting Concrete Barrier Rail* will be measured and paid for at the contract unit price bid per each and will be full compensation for removal, containment and disposal of existing material and concrete and shall include the cost of labor, tools, equipment and incidentals necessary to complete the work.

<b>Pay Item</b>	<b>Pay Unit</b>
Saw Cutting Concrete Barrier Rail	Each

**MODULAR EXPANSION JOINT SEALS FOR PRESERVATION (SPECIAL)**

**DESCRIPTION**

This special provision consists of furnishing, repairing, and installing modular expansion joint seals and glands within the limits indicated on the plans and in accordance with this special provision, the *Standard Specifications*, and the manufacturer's recommendations. All materials, labor, equipment, and incidentals necessary for the proper installation of the modular expansion joint seals are included.

**MATERIALS**

Obtain modular expansion joint seals from Fabricators that are AISC certified in Category I.



Complete Modular Expansion Joint Seal Assemblies:

Use a modular expansion joint seal that is a waterproof system such as WABOMODULAR as manufactured by Watson Bowman and Acme Corporation of Amherst New York, BROWN/MAURER as manufactured by the D. S. Brown Company of North Baltimore, Ohio or an approved equal. Do not use aluminum components in the modular expansion joint. Use a modular expansion joint seal consisting of three or more transverse rails holding two or more elastomeric seals in place and a support mechanism that ensures the rails maintain parallel and equidistant spacing. Do not use bolts to connect the rails to the support mechanism.

Provide an elastomeric component for each modular expansion joint seal that is one continuous unit for the entire length of the joint. Do not field splice the elastomeric component. Only vulcanized shop splicing of the elastomeric component is permitted. Provide an elastomeric component that is clearly shop marked to indicate the top side and joint location of the elastomeric component. On skewed bridges, or under unsymmetrical conditions, clearly mark the left side of the elastomeric component also. Left is defined as being on the left when facing in the direction of increasing station. Inspect the seals upon receipt to ensure that the marks are clearly visible upon installation.

Provide modular expansion joint seals capable of handling a total movement measured parallel to the centerline of the roadway as shown on plans. Limit clear distance between centerbeams, and edgebeams and centerbeams, to 3½". Limit centerbeam spans to approximately 48".

Modular Expansion Joint Seal Gland Replacement:

The Contractor is responsible for examining the existing modular expansion joint seal assemblies called out on the plans and locating the manufacturer's identification markings, which are usually on the turned-up portions of the joint assembly rails under the barrier rail covers or sidewalk covers. The Contractor will use these identification numbers to work with the manufacturer's on selecting the correct seal glands for the joint assemblies called out on the plans or as required by the Engineer.

**DRAWING AND SPECIFICATION SUBMITTAL**

Submit Shop Drawings for Fabrication and Installation Procedure and Revised Contract Plan Sheets, showing revised details of the Structure contract plans.

**A. Shop Fabrication and Installation Procedure Drawings**

The deck slab is detailed in the contract plans with a required full depth transverse construction joint separating the main slab pour from the blockout area for the modular joint assembly.

Position the modular joint assembly in the blockout area only after the main slab pours adjacent to the blockout area have been made and the girder rotation, deflection, and longitudinal movement due to slab pours have occurred.

Detail the method of positioning and securing the modular assembly in the blockout prior to the closure pour on the working drawings.

Submit two complete sets of working drawings for review. Submit these drawings well in advance of the scheduled installation time for the modular expansion joint seals. Include material requirements and installation procedures and specifications in the drawings.

After the drawings have been reviewed and, if necessary, corrections have been made, submit nine additional sets of the working drawings.

#### B. Revised Contract Plan Sheets

Concurrent with the submission of the working drawings, submit two sets of revised Structure plans for review. In the revised plans, include necessary changes in dimensions, reinforcing steel, and concrete blockouts to accommodate modular expansion joint seals. Have a North Carolina Registered Professional Engineer prepare and seal the revised plans. No adjustment will be made in the contract price for any bid item due to revisions necessary to accommodate the modular expansion joint seals. This cost is included in the lump sum price bid for furnishing and installing the modular expansion joint seal.

After the revised plans have been reviewed and, if necessary, corrections have been made, submit one 22" x 34" reproducible set of revised structure contract plans.

#### **REPLACING EXISTING JOINT SEAL GLAND**

If plans call for replacement of existing joint seal gland, only, without the rebuilding of the joint with new headers, etc., completely remove the existing joint seal material, adhesive, or other debris and deleterious materials in the joint as per the manufacturer's recommendations.

Inspect the condition of the existing components for cracks, deformations or other damage that the Engineer might determine necessitates replacement.

Place new joint seals as indicated in this special provision following the manufacturer's recommendations.

#### **FABRICATION AND INSTALLATION**

Protect the components of the modular expansion joint seal in the following manner. Upon completion of any shop fabrication, commercially blast clean (SP-6) all steel components, excluding stainless steel parts. Metallize to a minimum thickness of 8 mils on these surfaces. Metallize in accordance with the Special Provision for "Thermal Sprayed Coatings (Metallization)". Repair abraded or damaged coated surfaces anytime after applying the coating as specified for repair of galvanizing in the Standard Specifications. As an alternative to Metallizing, galvanizing in accordance with the Standard Specifications is permitted.

Install the modular expansion joint seals according to the procedures and recommendations of the manufacturer, except as amended in the next paragraph.

Limit modular expansion joint seal splices to crown points, abrupt changes in deck slab cross slope, lane lines, or as necessary for proper installation and alignment. All splice locations and details must

be shown on the submitted working drawings and are subject to the Engineer's approval. For shop splices, full penetration welds are required for centerbeam splices. For shop splices, partial penetration welds are not allowed for centerbeam splices, except at barrier rail upturns or sidewalk upturns. For field splices, partial penetration welds are not allowed for centerbeam splices. Show and submit for approval all splice locations on the working drawings. For location of lane markings at the modular expansion joint seals, see the Structure plans.

When indicated on the plans, provide special snowplow protection, such as a snowplow blade guide or steel ribs, to prevent the blade from entering the joint recess.

If the Engineer deems any aspects of the modular expansion joint seals unacceptable, make necessary corrections.

#### Watertight Integrity Test

- Upon completion of each modular expansion joint seal, perform a water test on the top surface to detect any leakage. Cover the roadway section of the joint from curb to curb, or barrier rail to barrier rail, with water, either ponded or flowing, not less than 1 inch above the roadway surface at all points. Block sidewalk sections and secure an unnozzled water hose delivering approximately 1 gallon of water per minute to the inside face of the bridge railing, trained in a downward position about 6 inches above the sidewalk, such that there is continuous flow of water across the sidewalk and down the curb face of the joint.
- Maintain the ponding or flowing of water on the roadway and continuous flow across sidewalks and curbs for a period of 5 hours. At the conclusion of the test, the underside of the joint is closely examined for leakage. The modular expansion joint seal is considered watertight if no obvious wetness is visible on the Engineer's finger after touching a number of underdeck areas. Damp concrete that does not impart wetness to the finger is not considered a sign of leakage.
- If the joint system leaks, locate the place(s) of leakage and take any repair measures necessary to stop the leakage at no additional cost to the Department. Use repair measures recommended by the manufacturer and approved by the Engineer prior to beginning corrective work.
- If measures to eliminate leakage are taken, perform a subsequent water integrity test subject to the same conditions as the original test. Subsequent tests carry the same responsibility as the original test and are performed at no additional cost to the Department.

#### **BASIS OF PAYMENT**

*Modular Expansion Joint Seals for Preservation* will be measured and paid for at the contract bid price per linear foot and payment will be full compensation for removal of existing joint seals and cover plates, furnishing and installing all material, including any steel accessory plates for sidewalks, medians and rails, any replacement steel cover plates or hardware, labor, tools, and incidentals necessary for installing the joint seal in place and including all materials, labor, tools and incidentals for performing the original watertight integrity test.

Payment will be made under:

**Pay Item****Pay Unit**

Modular Expansion Joint Seals for Preservation

Linear Foot

**ELASTOMERIC CONCRETE FOR PRESERVATION****(2-11-19)****DESCRIPTION**

Elastomeric concrete is a mixture of a two-part polymer consisting of polyurethane and/or epoxy and kiln-dried aggregate. Provide an elastomeric concrete and binder system that is preapproved. Use the concrete in the blocked-out areas on both sides of the bridge deck joints as indicated on the plans.

**MATERIALS**

Provide materials that comply with the following minimum requirements at 14 days (or at the end of the specified curing time).

<b>ELASTOMERIC CONCRETE PROPERTIES</b>	<b>TEST METHOD</b>	<b>MINIMUM REQUIREMENT</b>
Compressive Strength, psi	ASTM D695	2000
5% Deflection Resilience	ASTM D695	95
Splitting Tensile Strength, psi	ASTM D3967	625
Bond Strength to Concrete, psi	ASTM C882 (C882M)	450
Durometer Hardness	ASTM D2240	50

<b>BINDER PROPERTIES (without aggregate)</b>	<b>TEST METHOD</b>	<b>MINIMUM REQUIREMENT</b>
Tensile Strength, psi	ASTM D638	1000
Ultimate Elongation	ASTM D638	150%
Tear Resistance, lb/in	ASTM D624	200

In addition to the requirements above, the elastomeric concrete must be resistant to water, chemical, UV and ozone exposure and withstand temperature extremes. Elastomeric concrete systems requiring preheated aggregates are not allowed.

**PREQUALIFICATION**

Manufacturers of elastomeric concrete materials shall submit samples (including aggregate, primer and binder materials) and a Type 3 certification in accordance with Article 106-3 of the *Standard Specifications* for prequalification to:

North Carolina Department of Transportation  
Materials and Tests Unit  
1801 Blue Ridge Road  
Raleigh, NC 27607

Prequalification will be determined for the system. Individual components will not be evaluated, nor will individual components of previously evaluated systems be deemed prequalified for use.

The submitted binder (a minimum volume of 1 gallon) and corresponding aggregate samples will be evaluated for compliance with the Materials requirements specified above. Systems satisfying all of the Materials requirements will be prequalified for a one (1) year period. Before the end of this period new product samples shall be resubmitted for prequalification evaluation.

If, at any time, any formulation or component modifications are made to a prequalified system that system will no longer be approved for use.

### **INSTALLATION**

The elastomeric concrete shall not be placed until the reinforced concrete deck slab or overlay has cured for seven (7) full days and reached a minimum strength of 3,000 psi.

Provide a manufacturer's representative at the bridge site during the installation of the elastomeric concrete to ensure that all steps being performed comply with all manufacturer installation requirements including, but not limited to: weather conditions (ambient temperature, relative humidity, precipitation, wind, etc.), concrete deck surface preparation, binder and aggregate mixing, primer application, elastomeric concrete placement, curing conditions and minimum curing time before joint exposure to traffic. Do not place elastomeric concrete if the ambient air or surface temperature is below 45°F.

Prepare the concrete surface within 48 hours prior to placing the elastomeric concrete. Before placing the elastomeric concrete, all concrete surfaces shall be thoroughly cleaned and dry. Sandblast the concrete surface in the block-out and clear the surface of all loose debris. Do not place the elastomeric concrete until the surface preparation is completed and approved.

Prepare and apply a primer, as per manufacturer's recommendations, to all concrete faces to be in contact with elastomeric concrete, and to areas specified by the manufacturer.

Prepare, batch, and place the elastomeric concrete in accordance with the manufacturer's instructions. Place the elastomeric concrete in the areas specified on the plans while the primer is still tacky and within two (2) hours after applying the primer. Trowel the elastomeric concrete to a smooth finish.

The joint opening in the elastomeric concrete shall match the formed opening in the concrete deck prior to sawing the joint.

### **FIELD SAMPLING**

Provide additional production material to allow freshly mixed elastomeric concrete to be sampled for acceptance. A minimum of six (6) 2-inch cube molds and three (3) 3-inch diameter x 6-inch cylinders will be taken by the Department for each day's production. Compression, splitting tensile, and durometer hardness testing will be performed by the Department to determine acceptance. Materials

failing to meet the requirements listed above are subject to removal and replacement at no cost to the Department.

#### **BASIS OF PAYMENT**

*Elastomeric Concrete for Preservation* will be measured and paid for at the contract unit price bid per cubic foot and will be full compensation for material, labor, tools, and equipment necessary for satisfactorily installing the elastomeric concrete in place.

<b>Pay Item</b>	<b>Pay Unit</b>
Elastomeric Concrete for Preservation	Cubic Feet

#### **3 BAR METAL RAIL REPAIR**

**(SPECIAL)**

##### **DESCRIPTION**

This work consists of removing existing damaged sections of 3 bar metal rail barrier rail from the structure in accordance with the limits and details shown on the plans, described herein and as established by the Engineer. This work also includes furnishing and installing sections of 3 bar metal rail in accordance with this special provision and Section 460 of the *Standard Specifications*. All materials, miscellaneous hardware, labor, equipment, traffic control, and incidentals necessary for the proper installation of the 3 bar metal rail are included.

Any portion of the structure that is damaged from construction operations shall be repaired to the Engineer's satisfaction, at no extra cost to the Department.

##### **REMOVAL AND PREPARATION**

Prior to any construction, take the necessary precautions to ensure debris from construction is not allowed to fall below the bridge deck.

Remove existing damaged 3 bar metal rail section components by methods approved by the Engineer.

Damaged post anchor assemblies may require shifting the post to either side of the existing post location to anchor into solid concrete. This will require drilling the existing concrete parapet and anchoring with an approved adhesive anchor rod system. In addition, all loose and unsound concrete shall be removed from the damaged post anchor locations and repaired.

Properly dispose of the removed damaged metal rails and concrete.

If the condition of the concrete is such that deep spalls or sheer faces result, notify the Engineer for the proper course of action.

Install new 3 bar metal rail components in accordance with Section 460 of the *Standard Specifications*.

**MEASUREMENT AND PAYMENT**

*3 Bar Metal Rail Repair* will be measured and paid for at the contract unit price bid per linear foot. Prices and payment will be full compensation for removal of existing damaged components, containment, disposal, repair of any concrete parapets, furnishing and installing all materials, and shall include the cost of labor, tools, equipment and incidentals necessary to complete the work.

<b>Pay Item</b>	<b>Pay Unit</b>
3 Bar Metal Rail Repair	Linear Foot

**REPAIRS TO PRESTRESSED CONCRETE GIRDERS****(SPECIAL)****DESCRIPTION**

Work includes removal of concrete in spalled and/ or delaminated areas of the existing prestressed concrete girders, in reasonably close conformity with the lines, depth, and details shown on the plans, described herein, and as established by the Engineer. This work also includes straightening, cleaning, and replacement of reinforcing steel; repair and retensioning of damaged prestressing strand(s); application of High Ratio Co-Polymerized Calcium Sulfonate (HRCSA) corrosion penetrant; doweling/ adhesively anchoring new reinforcing steel or studs; removing all loose materials; removing and disposing of debris; formwork; applying repair material; and protecting adjacent areas of the bridge and environment from work operations. The repair material shall be one of the materials described below, unless otherwise noted in the plans or special provisions.

The location and extent of repairs shown on the plans are general in nature. The Engineer shall determine the extent of removal in the field based on an evaluation of the condition of the exposed surfaces.

The Contractor shall coordinate removal operations with the Engineer. No more than 30% of the bearing area under a beam shall be removed without a temporary support system and approval from the Engineer.

Any portion of the structure that is damaged from construction operations shall be repaired to the Engineer's satisfaction, at no extra cost to the Department.

**SUBMITTALS**

Submit all of the following to the Engineer for review and approval before scheduling the pre-construction meeting. Allow 40 calendar days for review and approval, or acceptance, of working drawings, from the date they are received, until they are returned by the Engineer.

- (A) HRCSA (High Ratio Co-Polymerized Calcium Sulfonate) Penetrant
- (B) Polymer Modified Concrete Repair Material
- (C) Epoxy Mortar Repair Material
- (D) Temporary Work Platform
- (E) Strand Splice Device

**GENERAL SURFACE PREPARATION**

Prior to starting the repair operation, confirm and delineate all surfaces and areas assumed to be deteriorated by visually examining and sounding the concrete surface with a hammer (14 ounce or larger) or other approved method. The Engineer is the sole judge in determining the limits of deterioration.

Remove surface concrete to verify that a ½” sawcut depth will not damage existing reinforcing steel or prestressing strand. If confirmed, introduce a shallow saw cut a minimum ½” in depth around the repair area, at right angles to the concrete surface. Within the limits of the sawcut, remove all concrete to a minimum depth of ½”. Remove all unsound concrete in the repair area, and where the bond between existing concrete and reinforcing steel has been compromised, or where more than half of the diameter of the reinforcing steel is exposed, remove concrete 1 inch behind the reinforcing steel. For concrete removal, use a 17-pound (maximum) pneumatic hammer with points that do not exceed the width of the shank or use hand picks or chisels as directed by the Engineer. Do not cut or remove the existing reinforcing steel. Unless specifically directed by the Engineer, do not remove concrete deeper than 1 inch below the reinforcing steel. Prevent cutting, stretching, or damaging of reinforcing steel.

Remove concrete and prepare concrete substrate such that placement of repair material in forms will adequately fill the repair area and will not result in air pockets or honeycombed area. Inside faces should generally be normal to the exterior face, except that the top should slope up toward the front of the form at an approximate 1:3 slope. Provide air vents as necessary. Interior corners should be rounded to a radius of approximately one inch (1”).

As necessary, remove grease, wax, salt, oil, and other contaminants by scrubbing with an industrial grade detergent or degreasing compound followed by a mechanical cleaning. Remove dirt, dust, laitance, and curing compounds by gritblasting, sanding, or etching with 15% hydrochloric acid. Acid etch only if approved by the Engineer. Follow acid etching by scrubbing and flushing with copious amounts of clean water. Check the cleaning using moist pH paper. Water cleaning is complete when the paper reads ten (10) or higher.

Abrasive blast all exposed concrete surfaces and existing reinforcing steel and strand in the repair area to clean the area and remove all loose materials. Use a wire brush or other hand tools to clean all exposed reinforcing steel and strand not sufficiently cleaned by blasting operations.

After blast cleaning, examine the reinforcing steel and prestressing strand. If there is more than 10% reduction in the diameter of reinforcing steel, splice in and securely tie supplemental reinforcing bars within the original concrete cover. Lap the bars sufficiently to develop the full strength of the bar and, if necessary, provide additional removal of concrete to achieve the required splice length. Reinforcing steel that is required for the repairs shall be in accordance with Section 425 of the *Standard Specifications*.

At beam ends where the end of prestressing strand might be free and not anchored in concrete, cut and remove prestressing strand back to even with the prepared concrete substrate. If the length of free, unanchored prestressing strand exceeds 12”, or if more than one column of prestressing strand is exposed, notify the Engineer immediately.

If four (4) or more prestressing strands have 50% or greater section loss from their original diameter, one half of the compromised strands shall be repaired by splicing of new strand section at the location



of the section loss. Device for splicing shall be a turnbuckle type device and shall be submitted to the Engineer for approval before beginning work. New splice section shall match size of existing strand, and splice device shall be sized for that size strand. Do not splice two (2) adjacent strands unless approved by the Engineer. For strands that are to be spliced, remove concrete such that the full section of the prestressing strand is exposed for a minimum of six (6) inches on each side of the section loss area. Following device manufacturer's recommendations, prepare the strand, removing concrete as necessary, and install splice device and new splice strand. Tensioning of the splice shall be turn-of-the-nut method.

At locations where strand splicing is required, replacement of concrete with repair material shall provide a minimum cover of one inch (1").

Follow all cleaning, remove all dust and loose material with air blast or vacuum cleaning.

Apply HRCSA Penetrant to the prepared reinforcing steel and prestressing strand. Do not apply excessive amount of HRCSA Penetrant; HRCSA shall not extend onto surrounding concrete by more than 1/4". HRCSA Penetrant shall be Zero Volatile Organic Compound (VOC), 100% Solids Penetrant/Sealer (Minimum 15% active sulfonate, a total base number of 135 to 165, must maintain a 9-11 to 1 ratio Active Sulfonate to Total Base Number as determined by Total Base Number Determination testing, Procedure No. 817/4.9/T1401). Allow HRCSA penetrant to dry before placing concrete repair material. Drying time is temperature, humidity, and film thickness dependent. Use manufacturer's recommended drying schedule to estimate the drying time of the penetrating sealer for application of the concrete repair material. If the manufacturer's recommendations allow, the use of forced air pressure to dry the surface will be permitted.

In repair areas that exceed one square foot (1.0 ft<sup>2</sup>) install adhesively anchored 1/4" diameter stainless steel studs in concrete on a 6" x 6" grid. Depth of embedment of adhesively anchored studs shall be 2". Install studs such that concrete cover on the studs is a minimum of one inch (1").

## **REPAIR MATERIAL OPTIONS**

### **(A) Polymer Modified Concrete Repair Material**

Repair material shall be polymer modified cement mortar/grout for vertical or overhead applications and shall be suitable for applications in marine environments. Material shall be approved for use by NCDOT. Submit repair material to the Engineer for review and approval prior to beginning the work. Color of repair material shall be concrete gray.

Prior to the application of polymer modified cement mortar/grout, prepare concrete substrate as indicated in "General Surface Preparation," above. Final preparation of the substrate concrete surface prior to repair material application shall be in accordance with the repair material manufacturer's recommendations.

When surface preparation is completed, mix and apply repair mortar in accordance with manufacturer's recommendations. Use aggregate that is washed, kiln-dried, and bagged. Aggregate size for repair material shall not exceed 2/3 of the minimum depth of the repair area, or 3/4 of the depth of excavation behind the reinforcing steel, whichever is smaller. As recommended by the repair material manufacturer, apply bonding agent to all repair areas immediately prior to placing repair mortar. Repair areas shall be formed, unless otherwise

approved by the Engineer. Form areas to establish the original neat lines of the member being repaired, unless otherwise approved by the Engineer.

Unless otherwise allowed by the repair material recommendations, forms shall remain in place until repair material achieves 75% of its design compressive strength.

After placing the repair mortar and form removal, remove excessive material and provide a smooth, flush surface.

#### (B) Epoxy Mortar Repair Material

Use a two-component paste epoxy bonding agent for the epoxy mortar conforming to the requirements for Type 2 epoxies as outlined in Section 1081 of the *Standard Specifications* and Type III epoxies as outlined in ASTM C881.

Prior to the application of epoxy mortar/grout, prepare concrete substrate as indicated in "General Surface Preparation," above. Final preparation of the substrate concrete surface prior to repair material application shall be in accordance with the repair material manufacturer's recommendations.

When surface preparation is completed, mix and apply repair epoxy mortar in accordance with manufacturer's recommendations. Use aggregate that is washed, kiln-dried, and bagged. Aggregate size for repair material shall not exceed 2/3 of the minimum depth of the repair area, or 3/4 of the depth of excavation behind the reinforcing steel, whichever is smaller. Repair areas shall be formed, unless otherwise approved by the Engineer. Form areas to establish the original neat lines of the member being repaired, unless otherwise approved by the Engineer.

Unless otherwise allowed by the repair material recommendations, forms shall remain in place until repair material achieves 75% of its design compressive strength.

After placing the repair mortar and form removal, remove excessive material and provide a smooth, flush surface.

#### TEMPORARY WORK PLATFORM

Prior to beginning any repair work, provide details for a sufficiently sized temporary work platform at each repair location. Design steel members to meet the requirements of the *American Institute of Steel Construction Manual*. Design timber members in accordance with the *National Design Specification for Stress-Grade Lumber and Its Fastenings* of the National Forest Products Association. Submit the platform design and plans for review and approval. The design and plans shall be sealed and signed by a North Carolina registered Professional Engineer. Do not install the platform until the design and plans are approved. Drilling holes in the superstructure for the purpose of attaching the platform is prohibited. Upon completion of work, remove all anchorages in the substructure and repair the substructure at no additional cost to the Department.

#### MEASUREMENT AND PAYMENT

*Repairs to Prestressed Concrete Girders* will be measured and paid for at the contract unit price bid per cubic foot and will be full compensation for removal, containment and disposal off-site of unsound concrete, including the cost of materials, reinforcing steel, labor, tools, equipment and incidentals necessary to complete the repair work. Depth will be measured from the original outside concrete face.

The Contractor and Engineer will measure quantities after removal of unsound concrete and before application of repair material. Payment will also include the cost of sandblasting, surface cleaning and preparation, cleaning of reinforcing steel, placement of new reinforcing steel, furnishing and application of HRCSA penetrant, furnishing and installation of temporary work platform, testing of the soundness of the exposed concrete surface, furnishing and installation of repair mortar/grout material, curing and sampling of mortar/grout, and protection/cleaning of adjacent areas from splatter or leakage.

Payment will be made under:

<b>Pay Item</b>	<b>Pay Unit</b>
Repairs to Prestressed Concrete Girders	Cubic Feet

### **THERMAL SPRAYED COATINGS (METALLIZATION)**

**(12-1-2017)**

#### **DESCRIPTION**

Apply a thermal sprayed coating (TSC) and sealer to metal surfaces in accordance with the Thermal Sprayed Coatings (Metallization) Program and as specified herein when called for on the plans or by other Special Provisions. Use only Arc Sprayed application methods to apply TSC. The Engineer must approve other methods of application.

The Thermal Sprayed Coatings (Metallization) Program is available on the Materials and Tests Unit website.

#### **QUALIFICATIONS**

Only use NCDOT approved TSC Contractors meeting the requirements outlined in the Thermal Sprayed Coatings (Metallization) Program.

#### **MATERIALS**

Use only materials meeting the requirements of Section 7 of the Thermal Sprayed Coatings (Metallization) Program.

#### **SURFACE PREPARATION AND TSC APPLICATION**

Surface preparation of TSC surfaces shall meet the requirements of Section 8 of the Thermal Sprayed Coatings (Metallization) Program. Apply TSC with the alloy to the thickness specified on the plans or as required by Thermal Sprayed Coatings (Metallization) Program.

#### **INSPECTION AND TESTING**

The TSC Contractor must conduct inspections and tests listed in the Thermal Sprayed Coatings (Metallization) Program.

#### **REPAIRS**

Perform all shop repairs in accordance with the procedures outlined in the Thermal Sprayed Coatings (Metallization) Program.

Repairs associated with field welding shall be made by removing the existing metallizing by blast or power tool cleaning. Affected areas shall be addressed as follows:

- For Marine Environments, incorporate a minimum surface preparation in accordance with SSPC SP-11 (Power Tool Cleaning to Bare Metal) and require an approved epoxy mastic coating applied in accordance with the manufacturer's recommendation. Apply a minimum of two (2) coats at a rate of 5-7 (WFT) per coat to the affected area.
- For Non-Marine Environments, incorporate a minimum surface preparation in accordance with SSPC SP-11 (Power Tool Cleaning to Bare Metal) and require an approved organic zinc-rich coating applied in accordance with the manufacturer's recommendation. Apply a minimum of two (2) coats at a rate of 5-7 (WFT) per coat to the affected area.
  1. Minor localized areas less than or equal to 0.1 ft<sup>2</sup> with exposed substrate shall be repaired as outlined above for marine and non-marine environments.
  2. Large localized areas greater than 0.1 ft<sup>2</sup> with exposed substrate shall require the Contractor to submit a detailed repair procedure to the Engineer for review and approval.
- Repair methods for areas where the substrate has not been exposed shall be mutually agreed upon between the Contractor and TSC Contractor as approved by the Engineer.

#### **TWELVE MONTH OBSERVATION PERIOD**

All TSC materials applied under the Thermal Sprayed Coatings (Metallization) Program shall be evaluated twelve (12) months after project acceptance for defective materials and workmanship.

#### **BASIS OF PAYMENT**

The contract price bid for the metal component to which the TSC is applied will be full compensation for the thermal sprayed coating.

#### **RAILROAD CONTRACTOR PROTECTIVE SERVICES**

**(SPECIAL)**

#### **DESCRIPTION**

Procure railroad protective services as specified by Norfolk Southern Railway Company (NS) Special Provisions for Protection of Railway Interests – Direct Hire Provision, for all work on NS property.

**METHODS**

Coordinate with NS Risk Management, upon submission of Right of Entry to work on railroad property, to hire qualified protective service contractors vetted by the railroad. Provide the service of properly equipped and qualified flaggers (per NS requirements) at locations and times for such period as necessary for the control and protection of activities on or adjacent to rail property and/or having the potential to foul the railroad’s track or operations. Contractor shall recognize that while the Contractor has procured and contracted with said protective service contractor, the protective service contractor has a responsibility to report directly to NS regarding any issues related to the safety of railroad operations. Qualification consists of each flagger receiving proper training in the set-up and techniques of safely and competently performing railroad protective services for the specific project limits.

**MEASUREMENT AND PAYMENT**

*Railroad Contractor Protective Services* will be measured and paid as the actual number of days that each flagger is satisfactorily provided and accepted by the Engineer during the life of the project. On any calendar day that more than one protective service personnel are used, the quantity to be paid on that calendar day will be the maximum number of protective service personnel used at one time in that calendar day. Total compensation under this pay item shall include labor (based on 12 hours per day), labor additive (protective service company directed), travel expenses, meals, lodging, and any rental vehicle costs. No measurement or payment will be made for railroad contractor protective services conducted for the convenience of the Contractor.

Payment will be made under:

**PAY ITEM**

Railroad Contractor Protective Services

**PAY UNIT**

Day

Norfolk Southern Railway Company



## E. Norfolk Southern – Special Provisions for Protection of Railway Interests

### 1. AUTHORITY OF RAILROAD ENGINEER AND SPONSOR ENGINEER:

Norfolk Southern Railway Company, hereinafter referred to as "Railroad", and their authorized representative shall have final authority in all matters affecting the safe maintenance of railroad traffic including the adequacy of the foundations and structures supporting the railroad tracks. For Public Projects impacting the Railroad, the Railroad's Public Improvements Engineer or Engineer Planning, hereinafter referred to as "Railroad Engineer", will serve as the authorized representative of the Railroad.

A general engineering consultant may be utilized to assist the Railroad Engineer in handling the Project, hereinafter referred to as "Construction Engineering Representative".

Other designated personnel by the Railroad Engineer shall hereinafter be referred to as "Railroad Representative".

The authorized representative of the Project Sponsor ("Sponsor"), hereinafter referred to as the "Sponsor's Engineer", shall have authority over all other matters as prescribed herein and in the Project Specifications.

The Sponsor's Prime Contractor, hereinafter referred to as "Contractor" shall be responsible for completing any and all work in accordance with the terms prescribed herein and in the Project Specifications. This shall include the qualified protective services of a contractor directly hired by the Contractor to protect their workers and construction activities while working on or adjacent to Railroad property, hereinafter referred to as "Contractor Protective Services".

This document titled E. Norfolk Southern – Special Provisions for Protection of Railway Interests shall hereinafter be referred to as "Special Provisions".

These terms and conditions are subject to change without notice at the sole discretion of the Railroad. The Contractor must request the latest version of these Special Provisions from the Railroad prior to commencing work and must follow the requirements outlined therein.

### 2. AUTHORIZATION TO PROCEED:

- A. The Contractor shall not commence mobilizing to the Premises, as defined in the Norfolk Southern Contractor Right of Entry Agreement, until the Contractor has complied with the following conditions:
1. Signed and received a fully executed copy of the required Norfolk Southern Contractor Right of Entry Agreement. Contractor Right of Entry Agreements to be submitted via email to the Railroad Engineer.
  2. Obtained written approval from the Railroad of Railroad Protective Liability Insurance coverage as required by paragraph 14 herein. It should be noted that the Railroad does not accept notation of Railroad Protective insurance on a certificate of liability insurance form or Binders as Railroad must have the full original countersigned policy. Further, please note that mere receipt of the policy is not the only issue but review for compliance. Due to the number of projects system-wide, it typically takes a minimum of 30-45 days for the Railroad to review.

Norfolk Southern Railway Company



3. Held a preconstruction meeting between the Contractor, the Sponsor, Railroad Engineer and/or their Construction Engineering Representative and the Railroad Representative(s). NOTE: Railroad Representative(s) may choose to not attend the preconstruction meeting at their discretion.
  4. Obtained Contractor Protective Services as required by Section 8 herein.
  5. Furnished a schedule for all construction activities which may impact the Railroad's property or operations. NOTE: Contractor Protective Services shall be provided any time construction activities are taking place on or adjacent to the Railroad Property and/or has the potential to foul the Railroad's track or operations as required by Section 8 herein.
  6. Schedule an onsite start-of-work meeting between the Contractor, Contractor Protective Services personnel, Railroad Engineer and/or their Construction Engineering Representative and the Railroad Representative(s). NOTE: Railroad Representative(s) may choose to not attend the start-of-work meeting at their discretion.
  7. Obtained written authorization to proceed from the Railroad to begin mobilization to the Premises, as defined in the Norfolk Southern Contractor Right of Entry Agreement, such authorization to include an outline of specific conditions with which the Contractor must comply. Written Authorization will be issued by the Railroad once all items on the Norfolk Southern Checklist for Construction - Direct Hire have been completed.
- B. The Railroad's written authorization to proceed with the work shall include the names, addresses, and telephone numbers of the Railroad Representative(s) and any specific Construction Engineering Representative who shall be notified as hereinafter required. Where more than one representative is designated, the area of responsibility of each representative shall be specified.
- C. All project-related utility work that is to occur on, over, or under Railroad right-of-way must be coordinated with the Norfolk Southern Pipe and Wire Program. The Contractor must receive approval from the Norfolk Southern Pipe and Wire Program prior to commencing any utility work.
3. NOTICE OF STARTING WORK:
- A. Before undertaking any construction activities on the Premises, as defined in the Norfolk Southern Contractor Right of Entry Agreement, the Contractor shall:
    1. Notify the Railroad Representative(s) at least 72 hours in advance of any construction activities that Contractor Protective Services have been obtained for use.
    2. Hold an onsite start-of-work meeting between the Contractor, Contractor Protective Services personnel, Railroad Engineer and/or their Construction Engineering Representative and the Railroad Representative(s). NOTE: Railroad Representative(s) may choose to not attend the start of work meeting at their discretion.

Norfolk Southern Railway Company



3. Receive assurance from the qualified protective services contractor that the Contractor Protective Services are properly equipped and have been site specific trained by the Railroad Representative prior to performing the full duties of protecting the Contractor. Until assurance from the qualified protective services contractor is obtained, Contractor Protective Services may act as an observer until such Contractor Protective Services are site specific trained by the Railroad Representative. The reference to an "observer" is defined as a person who has the authority to deny access to Contractor's workers and machinery to a specified Railroad operation zone as directed to the qualified protective services contractor by Railroad and prevent those potential to foul work events which may put the Contractor's workers and machinery at risk for injury or damage.
4. INTERFERENCE WITH RAILROAD OPERATIONS:
- A. The Contractor shall so arrange and conduct the Contractor's work that there will be no interference with Railroad's operations, including train, signal, telephone and telegraphic services, or damage to the property of the Railroad or to poles, wires, and other facilities of tenants on the rights-of-way of the Railroad. Whenever work is liable to affect the operations or safety of trains, the method of doing such work shall first be submitted to the Railroad Engineer for approval, but such approval shall not relieve the Contractor from liability. Any work to be performed by the Contractor which requires Construction Engineering Representative inspection services shall be deferred by the Contractor until the Construction Engineering Representative inspection services are available at the job site. Contractor Protective Services shall be provided onsite any time construction activities are taking place on or adjacent to the Railroad Property and/or has the potential to foul the Railroad's track or operations
  - B. Whenever work within Railroad's rights-of-way is of such a nature that impediment to Railroad's operations such as use of runaround tracks or necessity for reduced speed is unavoidable, the Contractor shall schedule and conduct the Contractor's operations so that such impediment is reduced to the absolute minimum.
  - C. Should conditions arising from, or in connection with the work, require that immediate and unusual provisions be made to protect operations and property of the Railroad, the Contractor shall make such provisions. If in the judgment of the Railroad Engineer, or in the Railroad Engineer's absence, the Railroad's Division Engineer, such provisions are insufficient, either may require or provide such provisions as the Railroad deems necessary. In any event, such unusual provisions shall be at the Contractor's expense and without cost to the Railroad or the Sponsor.
  - D. "One Call" Services do not locate buried Norfolk Southern Signals and Communications Lines. The contractor shall contact the Railroad's representative 7 days in advance of work at those places where excavation, pile driving, or heavy loads may damage the Railroad's underground facilities. Upon request from the Contractor or Sponsor, Railroad forces will locate and paint mark or flag the Railroad's underground facilities. The Contractor shall avoid excavation or other disturbances of these facilities. If disturbance or excavation is required near a buried Railroad facility, the contractor shall coordinate with the Railroad to have the facility potholed manually with careful hand excavation. The facility shall be protected by the Contractor during the course of the disturbance under the supervision and direction of the Railroad's Representative.



Norfolk Southern Railway Company



5. TRACK CLEARANCES:

- A. The minimum track clearances to be maintained by the Contractor during construction are shown on the Project Plans. If temporary clearances are not shown on the project plans, the following criteria shall govern the use of falsework and formwork above or adjacent to operated tracks.
1. A minimum vertical clearance of 22'-0" above top of highest rail shall be maintained at all times.
  2. A minimum horizontal clearance of 13'-0" from centerline of tangent track or 14'-0" from centerline of curved track shall be maintained at all times. Additional horizontal clearance may be required in special cases to be safe for operating conditions. This additional clearance will be as determined by the Railroad Engineer.
  3. All proposed temporary clearances which are less than those listed above must be submitted to Railroad Engineer for approval prior to construction and must also be authorized by the regulatory body of the State if less than the legally prescribed clearances.
  4. The temporary clearance requirements noted above shall also apply to all other physical obstructions including, but not limited to: stockpiled materials, parked equipment, placement or driving of piles, and bracing or other construction supports.

6. CONSTRUCTION PROCEDURES:

A. General:

1. Construction work and operations by the Contractor on Railroad property shall be:
  - a. Subject to the inspection and approval of the Railroad Engineer or their designated Construction Engineering Representative.
  - b. In accordance with the Railroad's written outline of specific conditions.
  - c. In accordance with the Railroad's general rules, regulations and requirements including those relating to safety, fall protection and personal protective equipment.
  - d. In accordance with these Special Provisions.
2. Submittal Requirements
  - a. The Contractor shall submit all construction related correspondence and submittals electronically to the Railroad Engineer and/or their designated Construction Engineering Representative.
  - b. The contractor should anticipate a minimum of 45 days for NS and their Construction Engineering Representative to complete the review of all construction submittals. Time frames for reviews can vary significantly depending on the complexity of the project and the quality of submittals. Submittals requiring input from other departments may require additional time.

Norfolk Southern Railway Company



- c. All work in the vicinity of the Railroad's property that has the potential to affect the Railroad's train operations or disturb the Railroad's property must be submitted and approved by the Railroad prior to work being performed.
- d. All submittals and calculations must be signed and sealed by a registered engineer licensed in the state of the project work.
- e. All submittals shall first be approved by the Sponsor's Engineer prior to submission to the Railroad Engineer for review. Submittals are reviewed by the Railroad for impacts to Railroad operations only; therefore, approval from the Railroad Engineer shall not relieve the Contractor from liability.
- f. For all construction projects, the following submittals, but not limited to those listed below, shall be provided for review and approval when applicable:
  - (1) General Means and Methods
  - (2) Ballast Protection
  - (3) Construction Excavation & Shoring
  - (4) Pipe, Culvert, & Tunnel Installations
  - (5) Demolition Procedure
  - (6) Erection & Hoisting Procedure
  - (7) Debris Shielding or Containment
  - (8) Blasting
  - (9) Formwork for the bridge deck, diaphragms, overhang brackets, and protective platforms
  - (10) Bent Cap Falsework. A lift plan will be required if the contractor want to move the falsework over the tracks.
- g. For Undergrade Bridges (Bridges carrying the Railroad) the following submittals in addition to those listed above shall be provided for review and approval:
  - (1) Girder Shop Drawings including welding/fabrication procedures
  - (2) Bearing Shop Drawings and Material Certifications
  - (3) Shop Drawings for drainage, handrails/fencing, and expansion dams
  - (4) Concrete Mix Design
  - (5) Structural Steel, Rebar, and/or Strand Certifications
  - (6) 28-day Cylinder Test for Concrete Strength
  - (7) Waterproofing Material Certification
  - (8) Dampproofing materials
  - (9) Test Reports for all steel
  - (10) Foundation Construction Reports

Other submittals may be required upon request from the Railroad. Fabrication may not begin until the Railroad has approved the required shop drawings.

Norfolk Southern Railway Company



- h. The Contractor shall include in all submissions a detailed narrative indicating the progression of work with the anticipated timeframe to complete each task. Work will not be permitted to commence until the Contractor has provided the Railroad with a satisfactory plan that the project will be undertaken without scheduling, performance, or safety related issues. Submissions shall also provide: a listing of the anticipated equipment to be used, plan and profile views showing the location of all equipment to be used relative to the track centerline(s) shown, and a contingency plan of action covering the event that a primary piece of equipment malfunctions.

**B. Ballast Protection**

1. The Contractor shall submit the proposed ballast protection system detailing the specific filter fabric and anchorage system to be used during all construction activities.
2. The ballast protection is to extend 25' beyond the proposed limit of work, be installed at the start of the project and be continuously maintained to prevent all contaminants from entering the ballast section of all tracks for the entire duration of the project.

**C. Excavation:**

1. The subgrade of an operated track shall be maintained with edge of berm at least 10'-0" from centerline of track and not more than 24-inches below top of rail. Contractor will not be required to make existing section meet this specification if substandard, in which case the existing section will be maintained.
2. Additionally, the Railroad will require the installation of an OSHA approved handrail and orange construction safety fencing for all excavations of the Railroad right-of-way.

**D. Excavation for Structures and Shoring Protection:**

1. The Contractor will be required to take special precaution and care in connection with excavating and shoring pits, and in driving piles or sheeting for footings adjacent to tracks to provide adequate lateral support for the tracks and the loads which they carry, without disturbance of track alignment and surface, and to avoid obstructing track clearances with working equipment, tools or other material.
2. The use of shoring systems utilizing tiebacks shall not be permitted without written approval from the Railroad Engineer.
3. Shoring systems utilizing trench boxes shall not be permitted within the Theoretical Railroad Embankment (Zones 1, 2, or 3) as shown on NS Typical Drawing No. 4 – Shoring Requirements without written approval from the Railroad Engineer.
4. All plans and calculations for shoring shall be prepared, signed, and sealed by a Registered Professional Engineer licensed in the state of the proposed project, in accordance with Norfolk Southern's Overhead Grade Separation Design Criteria, subsection H.1.6 - Construction Excavation (Refer to Norfolk Southern Public Improvement Projects Manual Appendix H). The Registered Professional Engineer will be responsible for the accuracy for all controlling dimensions as well as the selection of soil design values which will accurately reflect the actual field conditions.

Norfolk Southern Railway Company



5. The Contractor shall provide a detailed installation and removal plan of the shoring components. Any component that will be installed via the use of a crane or any other lifting device shall be subject to the guidelines outlined in Section 6.G of these Special Provisions.
  6. The Contractor shall be required to survey the track(s) and Railroad embankment and provide a cross section of the proposed excavation in relation to the tracks.
  7. Calculations for the proposed shoring should include deflection calculations. The maximum deflection for excavations within 18'-0" of the centerline of the nearest track shall be 3/8". For all other cases, the max deflection shall not exceed 1/2".
  8. Additionally, the Railroad will require the installation of an OSHA approved handrail and orange construction safety fencing for all excavations of the Railroad right-of-way.
  9. The front face of shoring located closest to the NS track for all shoring setups located in Zone 2 (shown on NS Typical Drawing No. 4 – Shoring Requirements in Appendix I) shall remain in place and be cut off 2'-0" below the final ground elevation. The remaining shoring in Zone 2 and all shoring in Zone 1 may be removed and all voids must be backfilled with flowable fill.
- E. Pipe, Culvert, & Tunnel Installations
1. Pipe, Culvert, & Tunnel Installations shall be in accordance with the appropriate Norfolk Southern Design Specification as noted below:
    - a. For Open Cut Method refer to Norfolk Southern Public Improvement Projects Manual Appendix H.4.6.
    - b. For Jack and Bore Method refer to Norfolk Southern Public Improvement Projects Manual Appendix H.4.7.
    - c. For Tunneling Method refer to Norfolk Southern Public Improvement Projects Manual Appendix H.4.8.
  2. The installation methods provided are for pipes carrying storm water or open flow runoff. All other closed pipeline systems shall be installed in accordance Norfolk Southern's Pipe and Wire Program and the NSCE-8.
- F. Demolition Procedures
1. General
    - a. Demolition plans are required for all spans over the track(s), for all spans adjacent to the track(s), if located on (or partially on) Railroad right-of-way; and in all situations where cranes will be situated on, over, or adjacent to Railroad right-of-way and within a distance of the boom length plus 15'-0" from the centerline of track.
    - b. Railroad tracks and other Railroad property must be protected from damage during the procedure.

Norfolk Southern Railway Company

- c. A pre-demolition meeting shall be conducted with the Sponsor, the Railroad Engineer and/or the Construction Engineering Representative, and the key Contractor's personnel prior to the start of the demolition procedure.
- d. The Railroad Engineer and/or the Construction Engineering Representative must be present at the site during the entire demolition procedure period.
- e. Demolition of existing bridge decks in spans over the Railroad shall be performed in a controlled manner (i.e. saw-cutting). No impact equipment (track-mounted hoe-ram, jackhammers, etc.) may be used over the Railroad without approval by the Railroad Engineer.
- f. Existing, obsolete, bridge piers shall be removed to a sufficient depth below grade to enable restoration of the existing/proposed track ditch, but in no case less than 2'-0" below final grade.

**2. Submittal Requirements**

- a. In addition to the submittal requirements outlined in Section 6.A.2 of these Special Provisions, the Contractor shall submit the following for approval by the Railroad Engineer:
  - (1) A plan showing the location of cranes, horizontally and vertically, with proposed boom lengths, operating radii, counterweights, and delivery or disposal locations shown. The location of all tracks and other Railroad facilities as well as all obstructions such as wire lines, poles, adjacent structures, etc. must also be shown.
  - (2) Rating sheets showing that cranes or lifting devices are adequate for 150% of the actual weight of the pick, including all rigging components. A complete set of crane charts, including crane, counterweight, and boom nomenclature is to be submitted. Safety factors that may have been "built-in" to the crane charts are not to be considered when determining the 150% factor of safety.
  - (3) Plans and computations showing the weight of the pick must be submitted. Calculations shall be made from plans of the existing structure showing complete and sufficient details with supporting data for the demolition of the structure. If plans do not exist, lifting weights must be calculated from field measurements. The field measurements are to be made under the supervision of the Registered Professional Engineer submitting the procedure and calculations.

Norfolk Southern Railway Company



- (4) The Contractor shall provide a sketch of all rigging components from the crane's hook block to the object being hoisted. Catalog cuts or information sheets of all rigging components with their lifting capacities shall be provided. All rigging must be adequate for 150% of the actual weight of the pick. Safety factors that may have been "built-in" to the rating charts are not to be considered when determining the 150% factor of safety. All rigging components shall be clearly identified and tagged with their rated lifting capacities. The position of the rigging in the field shall not differ from what is shown on the final plan without prior review from the Sponsor and the Railroad.
- (5) A complete demolition procedure, including the order of lifts, time required for each lift, and any repositioning or re-hitching of the crane or cranes.
- (6) Design and supporting calculations for the temporary support of components, including but not limited to the stability of the superstructure during the temporary condition, temporary girder tie-downs and falsework.

3. Overhead Demolition Debris Shield

- a. The demolition debris shield shall be installed prior to the demolition of the bridge deck or other relevant portions of the superstructure over the track area to catch all falling debris.
- b. The demolition debris shield shall provide a minimum vertical clearance as specified in Section 5.A.1 of these Special Provisions or maintain the existing vertical clearance if the existing clearance is less than that specified in Section 5.A.1.
- c. The Contractor shall include the demolition debris shield installation/removal means and methods as part of the proposed demolition procedure submission.
- d. The Contractor shall submit the demolition debris shield design and supporting calculations for approval by the Railroad Engineer.
- e. The demolition debris shield shall have a minimum design load of 50 pounds per square foot plus the weight of the equipment, debris, personnel, and other loads to be carried.
- f. The Contractor shall include the proposed bridge deck removal procedure in its demolition means and methods and shall verify that the size and quantity of the demolition debris generated by the procedure does not exceed the shield design loads.
- g. The Contractor shall clean the demolition debris shield daily or more frequently as dictated either by the approved design parameters or as directed by the Railroad Engineer.

Norfolk Southern Railway Company



4. Vertical Demolition Debris Shield

- a. A vertical demolition debris shield may be required for substructure removals in close proximity to the Railroad's track and other facilities, as determined by the Railroad Engineer.

G. Erection & Hoisting Procedures

1. General

- a. Erection plans are required for all spans over the track(s), for all spans adjacent to the track(s), if located on (or partially on) Railroad right-of-way; and in all situations where cranes will be situated on, over, or adjacent to Railroad right-of-way and within a distance of the boom length plus 15'-0" from the centerline of track.
- b. Neither crane handoffs nor "walking" of cranes with suspended load will be permitted for erection on or over Railroad right-of-way.
- c. Railroad tracks and other Railroad property must be protected from damage during the erection procedure.
- d. A pre-erection meeting shall be conducted with the Sponsor, the Railroad Engineer and/or the Construction Engineering Representative, and the key Contractor's personnel prior to the start of the erection procedure.
- e. The Railroad Engineer and/or the Construction Engineering Representative must be present at the site during the entire erection procedure period.
- f. For field splices located over Railroad property, a minimum of 50% of the holes for each connection shall be filled with bolts or pins prior to releasing the crane. A minimum of 50% of the holes filled shall be filled with bolts. All bolts must be appropriately tightened. Any changes to previously approved field splice locations must be submitted to the Railroad for review and approval. Refer to Norfolk Southern's Overhead Grade Separation Design Criteria for additional splice details (Norfolk Southern Public Improvement Projects Manual Appendix H.1, Section 4.A.3.).

2. Submittal Requirements

- a. In addition to the submittal requirements outlined in Section 6.A.2 of these provisions, the Contractor shall submit the following for approval by the Railroad Engineer:
- (1) As-built beam seat elevations - All as-built bridge seats and top of rail elevations shall be furnished to the Railroad Engineer for review and verification at least 30 days in advance of the erection, to ensure that minimum vertical clearances as approved in the plans will be achieved.
  - (2) A plan showing the location of cranes, horizontally and vertically, with proposed boom lengths, operating radii, counterweights, and delivery or staging locations shown. The location of all tracks and other Railroad facilities as well as all obstructions such as wire lines, poles, adjacent structures, etc. must also be shown.

Norfolk Southern Railway Company



- (3) Rating sheets showing that cranes or lifting devices are adequate for 150% of the actual weight of the pick, including all rigging components. A complete set of crane charts, including crane, counterweight, and boom nomenclature is to be submitted. Safety factors that may have been "built-in" to the crane charts are not to be considered when determining the 150% factor of safety.
- (4) Plans and computations showing the weight of the pick must be submitted. Calculations shall be made from plans of the proposed structure showing complete and sufficient details with supporting data for the erection of the structure. If plans do not exist, lifting weights must be calculated from field measurements. The field measurements are to be made under the supervision of the Registered Professional Engineer submitting the procedure and calculations.
- (5) The Contractor shall provide a sketch of all rigging components from the crane's hook block to the object being hoisted. Catalog cuts or information sheets of all rigging components with their lifting capacities shall be provided. All rigging must be adequate for 150% of the actual weight of the pick. Safety factors that may have been "built-in" to the rating charts are not to be considered when determining the 150% factor of safety. All rigging components shall be clearly identified and tagged with their rated lifting capacities. The position of the rigging in the field shall not differ from what is shown on the final plan without prior review from the Sponsor and the Railroad.
- (6) A complete erection procedure, including the order of lifts, time required for each lift, and any repositioning or re-hitching of the crane or cranes.
- (7) Design and supporting calculations for the temporary support of components, including but not limited to temporary girder tie-downs and falsework.

H. Blasting:

1. The Contractor shall obtain advance approval of the Railroad Engineer and the Sponsor Engineer for use of explosives on or adjacent to Railroad property. The request for permission to use explosives shall include a detailed blasting plan. If permission for use of explosives is granted, the Contractor will be required to comply with additional provisions as designated by the Railroad Engineer.

I. Track Monitoring

1. At the direction of the Railroad Engineer, any activity that has the potential to disturb the Railroad track structure may require the Contractor to submit a detailed track monitoring program for approval by the Railroad Engineer.



Norfolk Southern Railway Company

2. The program shall specify the survey locations, the distance between the location points, and frequency of monitoring before, during, and after construction. Railroad reserves the right to modify the survey locations and monitoring frequency as necessary during the project.
  3. The survey data shall be collected in accordance with the approved frequency and immediately furnished to the Railroad Engineer for analysis.
  4. If any movement has occurred as determined by the Railroad Engineer, the Railroad will be immediately notified. Railroad, at its sole discretion, shall have the right to immediately require all Contractor operations to be ceased and determine what corrective action is required. Any corrective action required by the Railroad or performed by the Railroad including the monitoring of corrective action of the Contractor will be at project expense.
- J. Maintenance of Railroad Facilities:
1. The Contractor will be required to maintain all ditches and drainage structures free of silt or other obstructions which may result from the Contractor's operations and provide and maintain any erosion control measures as required. The Contractor will promptly repair eroded areas within Railroad rights-of-way and repair any other damage to the property of the Railroad or its tenants.
  2. If, in the course of construction, it may be necessary to block a ditch, pipe or other drainage facility, temporary pipes, ditches, or other drainage facilities shall be installed to maintain adequate drainage, as approved by the Railroad Engineer. Upon completion of the work, the temporary facilities shall be removed, and the permanent facilities restored.
  3. All such maintenance and repair of damages due to the Contractor's operations shall be done at the Contractor's expense.
- K. Storage of Materials and Equipment:
1. Materials and equipment shall not be stored where they will interfere with Railroad operations, nor on the rights-of-way of the Railroad without first having obtained permission from the Railroad Engineer, and such permission will be with the understanding that the Railroad will not be liable for damage to such material and equipment from any cause and that the Railroad Engineer may move or require the Contractor to move, at the Contractor's expense, such material and equipment.
  2. All grading or construction machinery that is left parked near the track unattended by Contractor Protective Services shall be effectively immobilized so that it cannot be moved by unauthorized persons. The Contractor shall protect, defend, indemnify and save the Railroad, and any associated, controlled or affiliated corporation, harmless from and against all losses, costs, expenses, claim, or liability for loss or damage to property or the loss of life or personal injury, arising out of or incident to the Contractor's failure to immobilize grading or construction machinery.

Norfolk Southern Railway Company

## L. Cleanup:

1. Upon completion of the work, the Contractor shall remove from within the limits of the Railroad rights-of-way, all machinery, equipment, surplus materials, falsework, rubbish or temporary buildings of the Contractor, and leave said rights-of-way in a neat condition satisfactory to the Railroad Engineer or the Railroad Representative.

## 7. DAMAGES:

- A. The Contractor shall assume all liability for any and all damages to the Contractor's work, employees, servants, equipment, and materials caused by Railroad traffic.
- B. Any cost incurred by the Railroad for repairing damages to its property or to property of its tenants, caused by or resulting from the operations of the Contractor, shall be paid directly to the Railroad by the Contractor.

## B. CONTRACTOR PROTECTIVE SERVICES:

## A. Requirements:

1. Qualified protective services are those services of a contractor, directly hired by the Prime Contractor, that have been vetted through the Railroad and are allowed to be performed on Railroad property.
2. Contractor Protective Services shall be onsite anytime construction activities are taking place on or adjacent to the Railroad Property and/or have the potential to foul the Railroad's track or operations.
3. Contractor Protective Services shall be those services of a subcontractor to the Contractor who have the ability to fully protect the Contractor's workers and machinery once the qualified protective services contractor confirms the Contractor Protective Services are properly equipped and site specific trained by the Railroad Representative. Contractor Protective Services may act as an observer until such Contractor Protective Services are site specific trained by the Railroad Representative. The reference to an "observer" is defined as a person who has the authority to deny access to Contractor's workers and machinery to a specified Railroad operation zone as directed to the qualified protective services contractor by Railroad and prevent those potential to foul work events which may put the Contractor's workers and machinery at risk for injury or damage.
4. Contractor Protective Services will not be allowed on the property until all items on the Norfolk Southern Checklist for Construction-Direct Hire have been completed and the authorization to proceed is given by the Railroad Engineer.
5. Under the terms of the agreement between the Sponsor and the Railroad, the Railroad has sole authority to determine the need for any Railroad Protective Services required to protect its operations or work designated to be done by the Railroad through the force account estimate.

Norfolk Southern Railway Company**9. HAUL ACROSS RAILROAD TRACK:**

- A. Where the plans show or imply that materials of any nature must be hauled across the Railroad's track, unless the plans clearly show that the Sponsor has included arrangements for such haul in its agreement with the Railroad, the Contractor will be required to make all necessary arrangements with the Railroad regarding means of transporting such materials across the Railroad's track. The Contractor or Sponsor will be required to bear all costs incidental to such crossings whether services are performed by the Contractor's own forces or by Railroad personnel.
- B. No crossing may be established for use by the Contractor for transporting materials or equipment across the tracks of the Railroad unless specific authority for its installation, maintenance, use, until the Contractor has a fully executed a temporary private crossing agreement between the Contractor and Railroad. The approval process for an agreement normally takes 90 days.

**10. WORK FOR THE BENEFIT OF THE CONTRACTOR:**

- A. All temporary or permanent changes in wire lines or other facilities which are considered necessary to the project are shown on the plans; included in the force account agreement between the Sponsor and the Railroad or will be covered by appropriate revisions to same which will be initiated and approved by the Sponsor and/or the Railroad.
- B. Should the Contractor desire any changes in addition to the above, then the Contractor shall make separate arrangements with the Railroad for same to be accomplished at the Contractor's expense.

**11. COOPERATION AND DELAYS:**

- A. It shall be the Contractor's responsibility to arrange a schedule with the Railroad for accomplishing stage construction involving work by the Railroad or tenants of the Railroad. In arranging the Contractor's schedule, the Contractor shall ascertain, from the Railroad, the lead time required for assembling crews and materials and shall make due allowance therefore.
- B. No charge or claim of the Contractor against either the Sponsor or the Railroad will be allowed for hindrance or delay on account of railroad traffic; any work done by the Railroad or other delay incident to or necessary for safe maintenance of railroad traffic or for any delays due to compliance with these Special Provisions.

**12. TRAINMAN'S WALKWAYS:**

- A. Along the outer side of each exterior track of multiple operated track, and on each side of single operated track, an unobstructed continuous space suitable for trainman's use in walking along trains, extending to a line not less than 10 feet from centerline of track, shall be maintained. Any temporary impediments to walkways and track drainage encroachments or obstructions allowed during work hours while Railroad's Protective Service is provided shall be removed before the close of each workday. If there is any excavation near the walkway, a handrail, with 10'-0" minimum clearance from centerline of track, shall be placed and must conform to AREMA and/or FRA standards.

Norfolk Southern Railway Company**13. GUIDELINES FOR PERSONNEL ON RAILROAD RIGHT-OF-WAY:**

- A. The Contractor and/or the Sponsor's personnel authorized to perform work on the Railroad's property as specified in Section 2 above are not required to complete Norfolk Southern Roadway Worker Protection Training; However, the Contractor and the Sponsor's personnel must be familiar with Norfolk Southern's standard operating rules and guidelines, should conduct themselves accordingly, and may be removed from the property for failure to follow these guidelines.
- B. All persons shall wear hard hats. Appropriate eye and hearing protection must be used. Working in shorts is prohibited. Shirts must cover shoulders, back and abdomen. Working in tennis or jogging shoes, sandals, boots with high heels, cowboy and other slip-on type boots is prohibited. Hard-sole, lace-up footwear, zippered boots or boots cinched up with straps which fit snugly about the ankle are adequate. Wearing of safety boots and reflective vests are required.
- C. No person is allowed to perform construction activities which may impact the Railroad's property or operations without specific authorization from the Contractor Protective Services.
- D. All persons working near track while train is passing are to lookout for dragging bands, chains and protruding or shifted cargo.
- E. No person is allowed to cross tracks without specific authorization from the Contractor Protective Services.
- F. All welders and cutting torches working within 25' of track must stop when train is passing.
- G. No steel tape or chain will be allowed to cross or touch rails without permission from the Contractor Protective Services.

**14. GUIDELINES FOR EQUIPMENT ON RAILROAD RIGHT-OF-WAY:**

- A. No crane or boom equipment will be allowed to set up to work or park within boom distance plus 15' of centerline of track without specific permission from Railroad Representative and Contractor Protective Services personnel.
- B. No crane or boom equipment will be allowed to foul track or lift a load over the track without the authorization from the Contractor Protective Services personnel who are site specific trained and properly equipped.
- C. All employees will stay with their machines when crane or boom equipment is pointed toward track.
- D. All cranes and boom equipment under load will stop work while train is passing (including pile driving).
- E. Swinging loads must be secured to prevent movement while train is passing.
- F. No loads will be suspended above a moving train.
- G. No equipment will be allowed within 25' of centerline of track without specific authorization of the Railroad Representative and Contractor Protective Services personnel.

Norfolk Southern Railway Company

- H. Trucks, tractors, or any equipment will not touch ballast line without specific permission from Railroad Representative and Contractor Protective Services personnel. At the beginning of each project that involves the Contractor working within 25' of the centerline of any track, orange construction fencing must be established. Orange construction fencing shall be established in accordance with the minimum temporary horizontal clearances contained in Section 5.A.2 and shall be maintained for the duration of construction.
- I. No equipment or load movement is permitted within 25' or above a standing train or Railroad equipment without specific authorization of the Contractor Protective Services personnel.
- J. All operating equipment within 25' of track must halt operations when a train is passing. All other operating equipment may be halted by the Contractor Protective Services personnel if said personnel views the operation to be dangerous to the passing train.
- K. All equipment, loads and cables are prohibited from touching rails.
- L. While clearing and grubbing, no vegetation will be removed from Railroad embankment with heavy equipment without specific permission from the Railroad Engineer, Railroad Representative and Contractor Protective Services personnel.
- M. No equipment or materials will be parked or stored on Railroad's property unless specific authorization is granted from the Railroad Engineer.
- N. All unattended equipment that is left parked on Railroad property shall be effectively immobilized so that it cannot be moved by unauthorized persons.
- O. All cranes and boom equipment will be turned away from track after each workday or whenever unattended by an operator.
- P. Prior to performing any crane operations, the Contractor shall establish a single point of contact for the Contractor Protective Services personnel to remain in communication with at all times. Contractor Protective Services personnel must also be in direct contact with the individual(s) directing the crane operation(s).

**15. INSURANCE:**

- A. In addition to any other forms of insurance or bonds required under the terms of the contract and specifications, the Prime Contractor will be required to carry insurance of the following kinds and amounts:
  - 1. A Commercial General Liability ("CGL") policy containing products and completed operations, bodily injury, property damage, and contractual liability coverage, with a combined single limit of not less than \$5,000,000 for each occurrence with a general aggregate limit of not less than \$5,000,000. Any portion of this requirement may be satisfied by a combination of General Liability and/or Excess/Umbrella Liability Coverage. The CGL policy shall provide additional insured coverage equivalent to at least as broad as ISO CG 20 10 11/85.

Norfolk Southern Railway Company

2. Automobile Liability Insurance with a current ISO occurrence form policy (or equivalent) and apply on an "any auto" (Symbol 1) basis, including coverage for all vehicles used in connection with the Work or Services on the leased property, providing annual limits of at least \$1,000,000 per occurrence for bodily injury and property damage combined including uninsured and underinsured motorist coverage, medical payment protection, and loading and unloading. This policy shall be endorsed to include Transportation Pollution Liability Broadened Coverage ISO CA 99 48 03 06 or MCS-90 if vehicles are subject to Federal jurisdiction. If this coverage is on a claims-made form, the Retro Active Date must be prior to the date of this Agreement and the policy endorsement must be maintained for not less than seven (7) years.
3. Workers' Compensation Insurance to meet fully the requirement of any compensation act, plan, or legislative enactment applicable in connection with the death, disability or injury of Licensee's officers, agents, servants, or employees arising directly or indirectly out of the performance of the work.
4. Employers' Liability Insurance with limits of not less than \$1,000,000 each accident, \$1,000,000 policy limit for disease, and \$1,000,000 each employee for disease.
5. All insurance required in Section 15.A (excluding any Workers' Compensation policy) shall name Norfolk Southern Railway and its parent, subsidiary, and affiliated companies as additional insureds with an appropriate endorsement to each policy.
6. All policies secured by Contractor, whether primary, excess, umbrella or otherwise, and providing coverage to the Railroad as an additional insured (i) are intended to take priority in responding and to pay before any insurance policies Railroad may have secured for itself must respond or pay and (ii) may not seek contribution from any policies the Railroad may have secured for itself.
7. No cross-liability exclusions are permitted that would apply to the additional insureds, and there may not be any restrictions in any policy that limits coverage for a claim brought by an additional insured against a named insured.
8. To the fullest extent permitted by law, all insurance furnished by Contractor in compliance with Section 15.A shall include a waiver of subrogation in favor of Railroad with an appropriate endorsement to each policy.
9. All policies required in Section 15.A shall not be subject to cancellation, termination, modification, changed, or non-renewed except upon thirty (30) days' prior written notice to the additional insureds.
10. The insurance coverages maintained by Contractor shall not limit any indemnity obligations or other liabilities. The insurance available to Railroad and its parent, subsidiary and affiliated companies as additional insureds shall not be limited by these requirements should Licensee maintain higher coverage limits.
11. Any deductibles or retentions in excess of \$50,000 maintained on any insurance required in 15.A shall be disclosed and approved by Railroad with a request made for approval to NSRISK3@nscorp.com.

Norfolk Southern Railway Company

12. Anyone subcontractor providing work on this project must extend CG 20 38 (or broader coverage) additional Insured endorsement to provide coverage for up stream parties.
  13. Contractor shall require all subcontractors who are not covered by the insurance carried by Contractor to obtain commercially reasonable insurance coverage, but not less than the requirements of 15.A.
- B. In addition to the insurances required in Section 15.A, the Contractor shall also procure on behalf of the Railroad for the entirety of the project:
1. Railroad Protective Liability (RPL) Insurance having a combined single limit of not less than \$5,000,000 each occurrence and \$10,000,000 in the aggregate applying separately to each annual period. Said policy shall provide coverage for all loss, damage or expense arising from bodily injury and property damage liability, and physical damage to property attributed to acts or omissions at the job site.

The standards for the Railroad Protective Liability Insurance are as follows:

- a. The insurer must be rated A- or better by A.M. Best Company, Inc.
- b. The policy must be written using one of the following combinations of Insurance Services Office ("ISO") RPL Insurance Form Numbers:
  - (1) CG 00 35 01 96 and CG 28 31 10 93; or
  - (2) CG 00 35 07 98 and CG 28 31 07 98; or
  - (3) CG 00 35 10 01; or
  - (4) CG 00 35 12 04; or
  - (5) CG 00 35 12 07; or
  - (6) CG 00 35 04 13.
- c. The named insured shall read:
 

Norfolk Southern Corporation and its subsidiaries and affiliates  
650 West Peachtree Street NW – Box 46  
Atlanta, GA 30308  
Attn: Risk Manager

**(NOTE: Railroad does not share coverage on RPL with any other entity on this policy)**
- d. The description of operations must appear on the Declarations, must match the project description in this agreement, and must include the appropriate Sponsor project and contract identification numbers.
- e. The job location must appear on the Declarations and must include the city, state, and appropriate highway name/number. **NOTE: Do not include any references to milepost, valuation station, or mile marker on the insurance policy.**
- f. The name and address of the prime Contractor must appear on the Declarations.

Norfolk Southern Railway Company



- g. The name and address of the Sponsor must be identified on the Declarations as the "Involved Governmental Authority or Other Contracting Party."
- h. Endorsements/forms that are required are:
- (1) Physical Damage to Property Amendment
  - (2) Terrorism Risk Insurance Act (TRIA) coverage must be included
- i. Other endorsements/forms that will be accepted are:
- (1) Broad Form Nuclear Exclusion – Form IL 00 21
  - (2) 30-day Advance Notice of Non-renewal or cancellation
  - (3) Required State Cancellation Endorsement
  - (4) Quick Reference or Index Form CL/IL 240
- j. Endorsements/forms that are NOT acceptable are:
- (1) Any Pollution Exclusion Endorsement except CG 28 31
  - (2) Any Punitive or Exemplary Damages Exclusion
  - (3) Known injury or Damage Exclusion form CG 00 59
  - (4) Any Common Policy Conditions form
  - (5) An Endorsement that limits or excludes Professional Liability coverage
  - (6) A Non-Cumulation of Liability or Pyramiding of Limits Endorsement
  - (7) An Endorsement that excludes TRIA coverage
  - (8) A Sole Agent Endorsement
  - (9) Any type of deductible endorsement or amendment
  - (10) Any other endorsement/form not specifically authorized in item no. 2.h above.

SPONSOR:

RAILROAD:

Risk Management  
 Norfolk Southern Corporation and its subsidiaries  
 650 West Peachtree Street NW – Box 46  
 Atlanta, GA 30308  
[NSRISK3@NSCORP.COM](mailto:NSRISK3@NSCORP.COM)

- C. All insurance required under Section 15.A and 15.B shall be underwritten by insurers and be of such form and content, as may be acceptable to the Railroad. Prior to entry on Railroad right-of-way, the original electronic RPL Insurance Policy shall be submitted by the Prime Contractor to the Railroad at [NSRISK3@NSCORP.COM](mailto:NSRISK3@NSCORP.COM) for review and approval. In addition, certificates of insurance evidencing the Prime Contractor's insurance compliant with the requirements in 15.A shall be issued to the Railroad at [NSRISK3@NSCORP.COM](mailto:NSRISK3@NSCORP.COM) at the same time the RPL Policy is submitted.
- D. The insurance required herein shall in no way serve to limit the liability of Sponsor or its Contractors under the terms of this agreement.



Norfolk Southern Railway Company



**E. Insurance Submission Procedures**

1. The Railroad will only accept initial insurance submissions via email to NSRISK3@NSCORP.COM. The Railroad will NOT accept initial insurance submissions via hard copies that would be sent either US Mail or Overnight carrier or faxes as only electronic versions only are to be submitted to Railroad. Please provide point of contact information with the submission including a phone number and email address.

For email insurance submissions, the subject line should follow the format provided unless otherwise directed by the Railroad Engineer:

Insurance Submittal: City, State – NS File Number – NS Milepost – Project Name – Sponsor Project #

2. Railroad requires the following two (2) forms of insurance in the initial electronic insurance submission to NSRISK3@NSCORP.COM to be submitted under a cover letter providing details of the project and containing the contact information:
  - a. The full original or certified true electronic countersigned copy of the RPL Insurance Policy in its entirety inclusive of all declarations, schedule of forms and endorsements along with the policy forms and endorsements as required in Section 15.B.
  - b. A certificate of insurance from the Contractor evidencing the Contractor's insurance in Section 15.A (i.e. the Contractor's commercial general, automobile, and workers' compensation liability insurance, etc.). The certificate must show Norfolk Southern Railroad and its subsidiaries and affiliated companies as an additional insured on the General Liability and Auto policies. The certificate should also indicate that the Workers' Compensation policy waives subrogation against Norfolk Southern Corporation and its subsidiaries. See Appendix J for a Sample Certificate of Insurance.

**16. FAILURE TO COMPLY:**

- A. In the event the Contractor violates or fails to comply with any of the requirements of these Special Provisions:
  1. The Railroad Engineer may require that the Contractor vacate Railroad property.
  2. The Sponsor's Engineer may withhold all monies due the Contractor on monthly statements.
- B. Any such orders shall remain in effect until the Contractor has remedied the situation to the satisfaction of the Railroad Engineer and the Sponsor's Engineer.

**17. PAYMENT FOR COST OF COMPLIANCE:**

- A. No separate payment will be made for any extra cost incurred on account of compliance with these Special Provisions. All such costs shall be included in prices bid for other items of the work as specified in the payment items.

Norfolk Southern Railway Company



18. PROJECT INFORMATION

- A. Date: \_\_\_\_\_
- B. NS File No.: \_\_\_\_\_
- C. NS Milepost: \_\_\_\_\_
- D. Sponsor's Project No. \_\_\_\_\_

County: WAKE, DURHAM

Line #	Item Number	Sec #	Description	Quantity	Unit Cost	Amount
<b>ROADWAY ITEMS</b>						
0001	0000100000-N	800	MOBILIZATION	Lump Sum	L.S.	
0002	0000820000-N	SP	GENERIC MISCELLANEOUS ITEM RAILROAD CONTRACTOR PROTECTIVE SERVICES	15 DAY		
0003	1330000000-E	607	INCIDENTAL MILLING	6,516.6 SY		
0004	1519000000-E	610	ASPHALT CONC SURFACE COURSE, TYPE S9.5B	550 TON		
0005	1575000000-E	620	ASPHALT BINDER FOR PLANT MIX	45 TON		
0006	3649000000-E	876	RIP RAP, CLASS B	180 TON		
0007	3656000000-E	876	GEOTEXTILE FOR DRAINAGE	200 SY		
0008	4400000000-E	1110	WORK ZONE SIGNS (STATIONARY)	808 SF		
0009	4405000000-E	1110	WORK ZONE SIGNS (PORTABLE)	556 SF		
0010	4410000000-E	1110	WORK ZONE SIGNS (BARRICADE MOUNTED)	324 SF		
0011	4415000000-N	1115	FLASHING ARROW BOARD	8 EA		
0012	4420000000-N	1120	PORTABLE CHANGEABLE MESSAGE SIGN	4 EA		
0013	4430000000-N	1130	DRUMS	390 EA		
0014	4445000000-E	1145	BARRICADES (TYPE III)	360 LF		
0015	4480000000-N	1165	TMA	6 EA		
0016	4770000000-E	1205	COLD APPLIED PLASTIC PAVEMENT MARKING LINES, TYPE ** (4") (I)	10,753 LF		

County: WAKE, DURHAM

Line #	Item Number	Sec #	Description	Quantity	Unit Cost	Amount
0017	4775000000-E	1205	COLD APPLIED PLASTIC PAVEMENT MARKING LINES, TYPE ** (6") (I)	963 LF		
0018	4780000000-E	1205	COLD APPLIED PLASTIC PAVEMENT MARKING LINES, TYPE ** (8") (I)	540 LF		
0019	4795000000-E	1205	COLD APPLIED PLASTIC PAVEMENT MARKING LINES, TYPE ** (24") (I)	95 LF		
0020	4805000000-N	1205	COLD APPLIED PLASTIC PAVEMENT MARKING SYMBOL, TYPE ** (I)	2 EA		
0021	4900000000-N	1251	PERMANENT RAISED PAVEMENT MARKERS	43 EA		
0022	5255000000-N	1413	PORTABLE LIGHTING	Lump Sum	L.S.	
0023	7444000000-E	1725	INDUCTIVE LOOP SAWCUT	4,400 LF		
0024	7456000000-E	1726	LEAD-IN CABLE (***** (14-2)	1,000 LF		
<b>STRUCTURE ITEMS</b>						
0025	8296000000-N	442	POLLUTION CONTROL	Lump Sum	L.S.	
0026	8660000000-E	SP	CONCRETE REPAIRS	9.5 CF		
0027	8664000000-E	SP	SHOTCRETE REPAIRS	18.3 CF		
0028	8860000000-N	SP	GENERIC STRUCTURE ITEM CLEANING AND PAINTING EXISTING WEATHERING STEEL FOR BRIDGE #911039	Lump Sum	L.S.	
0029	8860000000-N	SP	GENERIC STRUCTURE ITEM CLEANING AND PAINTING EXISTING WEATHERING STEEL FOR BRIDGE #911083	Lump Sum	L.S.	
0030	8860000000-N	SP	GENERIC STRUCTURE ITEM CLEANING AND REPAINTING OF BRIDGE #310306	Lump Sum	L.S.	

County: WAKE, DURHAM

Line #	Item Number	Sec #	Description	Quantity	Unit Cost	Amount
0031	8860000000-N	SP	GENERIC STRUCTURE ITEM PAINTING CONTAINMENT FOR BRIDGE #310306	Lump Sum	L.S.	
0032	8860000000-N	SP	GENERIC STRUCTURE ITEM PAINTING CONTAINMENT FOR BRIDGE #911039	Lump Sum	L.S.	
0033	8860000000-N	SP	GENERIC STRUCTURE ITEM PAINTING CONTAINMENT FOR BRIDGE #911083	Lump Sum	L.S.	
0034	8867000000-E	SP	GENERIC STRUCTURE ITEM 3 BAR METAL RAIL REPAIR	60 LF		
0035	8867000000-E	SP	GENERIC STRUCTURE ITEM EXPANSION JOINT SEALS FOR PRESERVATION	212.2 LF		
0036	8867000000-E	SP	GENERIC STRUCTURE ITEM FOAM JOINT SEALS FOR PRESERVATION	1,369.9 LF		
0037	8867000000-E	SP	GENERIC STRUCTURE ITEM MODULAR EXPANSION JOINT SEALS FOR PRESERVATION	73.4 LF		
0038	8867000000-E	SP	GENERIC STRUCTURE ITEM POURABLE SILICONE JOINT SEALANT	2,158 LF		
0039	8882000000-E	SP	GENERIC STRUCTURE ITEM ELASTOMERIC CONCRETE FOR PRESERVATION	503.7 CF		
0040	8889000000-E	SP	GENERIC STRUCTURE ITEM SLOPE PROTECTION VOID FILLING	1,260 LB		
0041	8892000000-E	SP	GENERIC STRUCTURE ITEM BRIDGE JOINT DEMOLITION	1,878.5 SF		
0042	8892000000-E	SP	GENERIC STRUCTURE ITEM EPOXY COATING	9,795.7 SF		
0043	8892000000-E	SP	GENERIC STRUCTURE ITEM EPOXY COATING CONCRETE GIRDER ENDS	1,664 SF		
0044	8892000000-E	SP	GENERIC STRUCTURE ITEM SILANE BARRIER RAIL TREATMENT	7,249.7 SF		
0045	8892000000-E	SP	GENERIC STRUCTURE ITEM SURFACE PREPARATION FOR CONCRETE BARRIER	7,249.7 SF		

County: WAKE, DURHAM

Line #	Item Number	Sec #	Description	Quantity	Unit Cost	Amount
0046	8893000000-E	SP	GENERIC STRUCTURE ITEM DIAMOND GRINDING CONCRETE APPROACH SLAB	210 SY		
0047	8893000000-E	SP	GENERIC STRUCTURE ITEM SHOTBLASTING BRIDGE DECK	16,315.6 SY		
0048	8893000000-E	SP	GENERIC STRUCTURE ITEM SILANE DECK TREATMENT	16,315.6 SY		
0049	8897000000-N	SP	GENERIC STRUCTURE ITEM SAW CUTTING CONCRETE BARRIER RAIL	4 EA		

1058/Jul05/Q94115.4/D317036920000/E49

**Total Amount Of Bid For Entire Project :**