

NOTES

REPAIR LOCATIONS AND ESTIMATE OF QUANTITIES ARE BASED ON THE BEST INFORMATION AVAILABLE. IF ADDITIONAL REPAIRS NOT SHOWN ON THE DRAWINGS ARE DEEMED NECESSARY BY THE ENGINEER, THE ENGINEER SHALL NOTE ON THE DRAWINGS THE APPROXIMATE LOCATION AND DESCRIPTION OF THE REPAIRS AND ENTER THE ACTUAL QUANTITIES INTO THE SUBSTRUCTURE REPAIR QUANTITY TABLE.



CLEAN AND REMOVE DEBRIS FROM THE TOP OF THE CAP AND APPLY EPOXY PROTECTIVE COATING. EPOXY COATING SHALL BE APPLIED TO THE TOP SURFACE OF THE CAP. THE CONTRACTOR SHALL NOT COAT THE AREA OF THE CAP BENEATH THE MASONRY PLATES.

CONCRETE REPAIRS MAYBE SUBSTITUTED IN LIEU OF SHOTCRETE REPAIRS WITH THE APPROVAL OF THE ENGINEER.

REMOVAL OF DEBRIS AND DISPOSAL OF EXISTING JOINT SEALANT MATERIAL FROM SLOPE PROTECTION PRIOR TO PLACEMENT OF BACKER ROD AND POURABLE SILICONE JOINT SEALANT SHALL BE CONSIDERED INCIDENTAL TO CONSTRUCTION.

POURABLE SILICONE JOINT SEALANT SHALL BE INSTALLED AS PER THE MANUFACTURER'S RECOMMENDATIONS.

THE INSTALLED POURABLE SILICONE JOINT SEALANT SHALL BE WATER TIGHT.

-  SHOTCRETE REPAIR AREA
-  CONCRETE REPAIR AREA
-  EPOXY RESIN INJECTION

SUBSTRUCTURE REPAIR QUANTITY TABLE

| END BENT 1 | QUANTITIES | | | |
|--------------------------------------|------------|------------|---------|-----------|
| | ESTIMATE | | ACTUAL | |
| SHOTCRETE REPAIRS | AREA SF | VOLUME CF | AREA SF | VOLUME CF |
| CAP | 0 | 0 | | |
| CURTAIN WALL | 0 | 0 | | |
| WINGWALL | | | | |
| CONCRETE REPAIRS | AREA SF | VOLUME CF | AREA SF | VOLUME CF |
| CAP | 0 | 0 | | |
| CURTAIN WALL | 0 | 0 | | |
| WINGWALL | | | | |
| EPOXY RESIN INJECTION | | LINEAR FT | | LINEAR FT |
| CAP | | 0 | | |
| CURTAIN WALL | | 0 | | |
| WINGWALL | | | | |
| POURABLE SILICONE JT. SEALANT | | LINEAR FT. | | AREA SF |
| JOINT | | 411.0 | | |
| | | | | |
| EPOXY COATING | | AREA SF | | AREA SF |
| CAP | | 855.1 | | |

VALUES IN CHART REPRESENT ESTIMATED REPAIR TOTALS AFTER REMOVAL OF UNSOUND CONCRETE, MIN. OF 1" BEHIND REBAR AND MIN. 2" CLEAR TO SAWCUT. SEE REPAIR DETAILS.

PLAN

TOP OF CAP

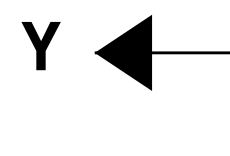

ELEVATION

LOOKING EAST

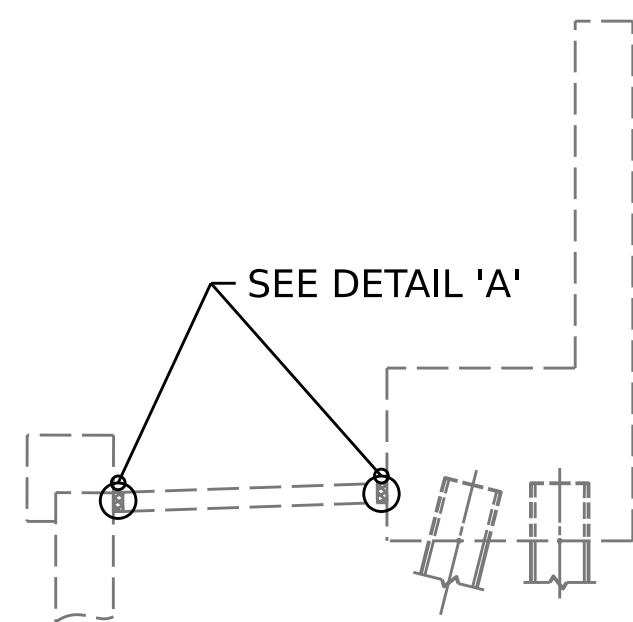
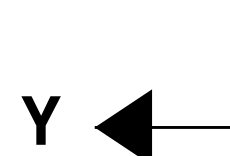

SECTION Y-Y

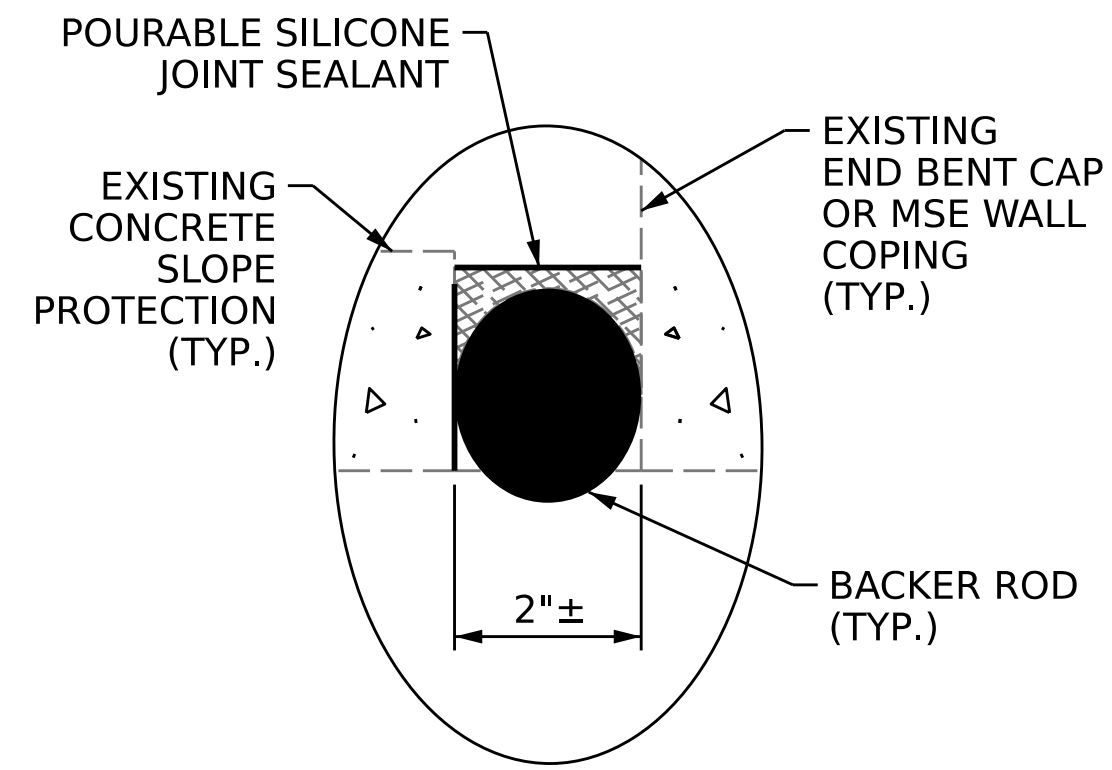

DETAIL 'A'

PROJECT NO. **15BPR.124.3**
WAKE COUNTY
 BRIDGE NO. **911083**

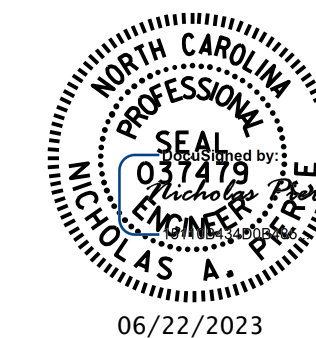

STATE OF NORTH CAROLINA
 DEPARTMENT OF TRANSPORTATION
 RALEIGH
 SUBSTRUCTURE REPAIR
END BENT 1

DRAWN BY : A.Y. GODFREY DATE : 09/2022
 CHECKED BY : R.L. PUTEK DATE : 10/2022
 DESIGN ENGINEER OF RECORD : N.A. PIERCE DATE : 12/2022

DOCUMENT NOT CONSIDERED FINAL UNLESS ALL SIGNATURES COMPLETED

| REVISIONS | | | | | | SHEET NO. S3-08 TOTAL SHEETS 12 |
|-----------|-----|-------|-----|-----|-------|--|
| NO. | BY: | DATE: | NO. | BY: | DATE: | |
| 1 | | | 3 | | | |
| 2 | | | 4 | | | |