

3/21/2023 8:16:26 AM P:\Raleigh\Projects\2019\Division 9 (Davenport)\B-5783\Structures\Drawings\NEW\280168_SB\B-5783_SMU_B1_280168.dgn

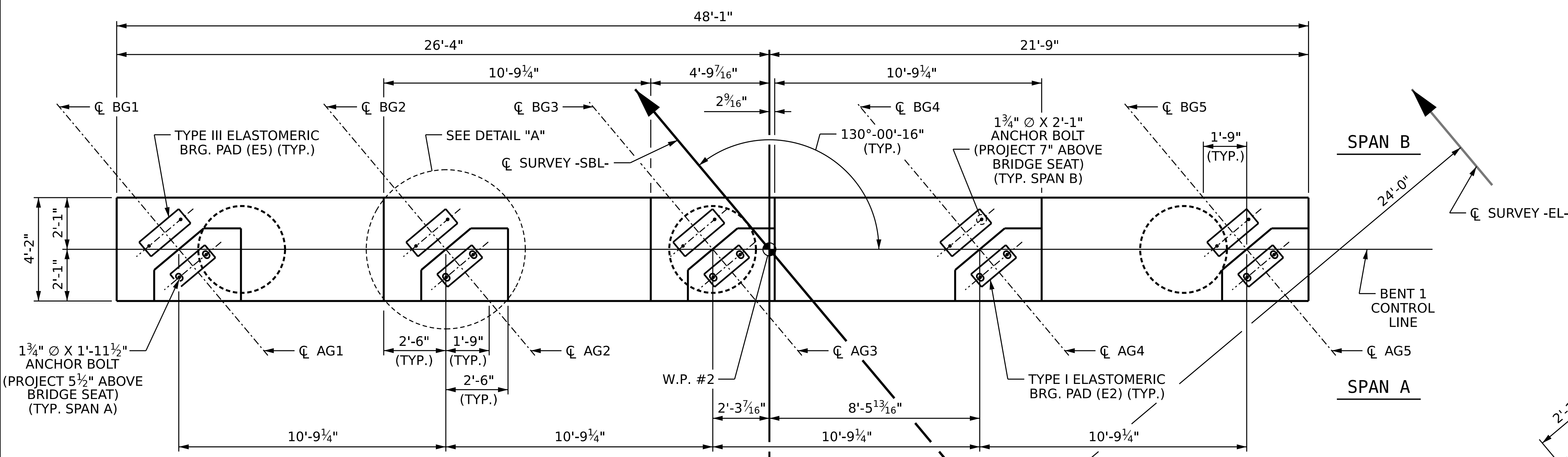

NOTES:

STIRRUPS AND "U" BARS IN CAP MAY BE SHIFTED AS NECESSARY TO CLEAR ANCHOR BOLTS.

HOOKS ON "V" BARS MAY BE TURNED AS NECESSARY FOR PLACING REINFORCING STEEL.

THE TOP SURFACE AREAS OF THE BENT CAP SHALL BE CURED IN ACCORDANCE WITH THE STANDARD SPECIFICATIONS EXCEPT THE MEMBRANE CURING COMPOUND METHOD SHALL NOT BE USED.

THE CONTRACTOR'S ATTENTION IS CALLED TO THE FACT THAT THE LONGITUDINAL REINFORCEMENT FOR THE DRILLED PIERS IS DETAILED WITH 3 FEET OF EXTRA LENGTH.

THE LOCATION OF THE CONSTRUCTION JOINT IN THE DRILLED PIERS IS BASED ON THE APPROXIMATE GROUND LINE ELEVATION. THE TOP OF DRILLED PIER SHALL BE ADJUSTED AS REQUIRED TO MAINTAIN THE DRILLED PIER 1 FOOT BELOW THE GROUND LINE ELEVATION.

* INVERT ALTERNATE STIRRUPS.

ALL STEEL IN THE DRILLED PIERS IS INCLUDED IN THE PAY ITEMS FOR "REINFORCING STEEL" AND "SPIRAL COLUMN REINFORCING STEEL".

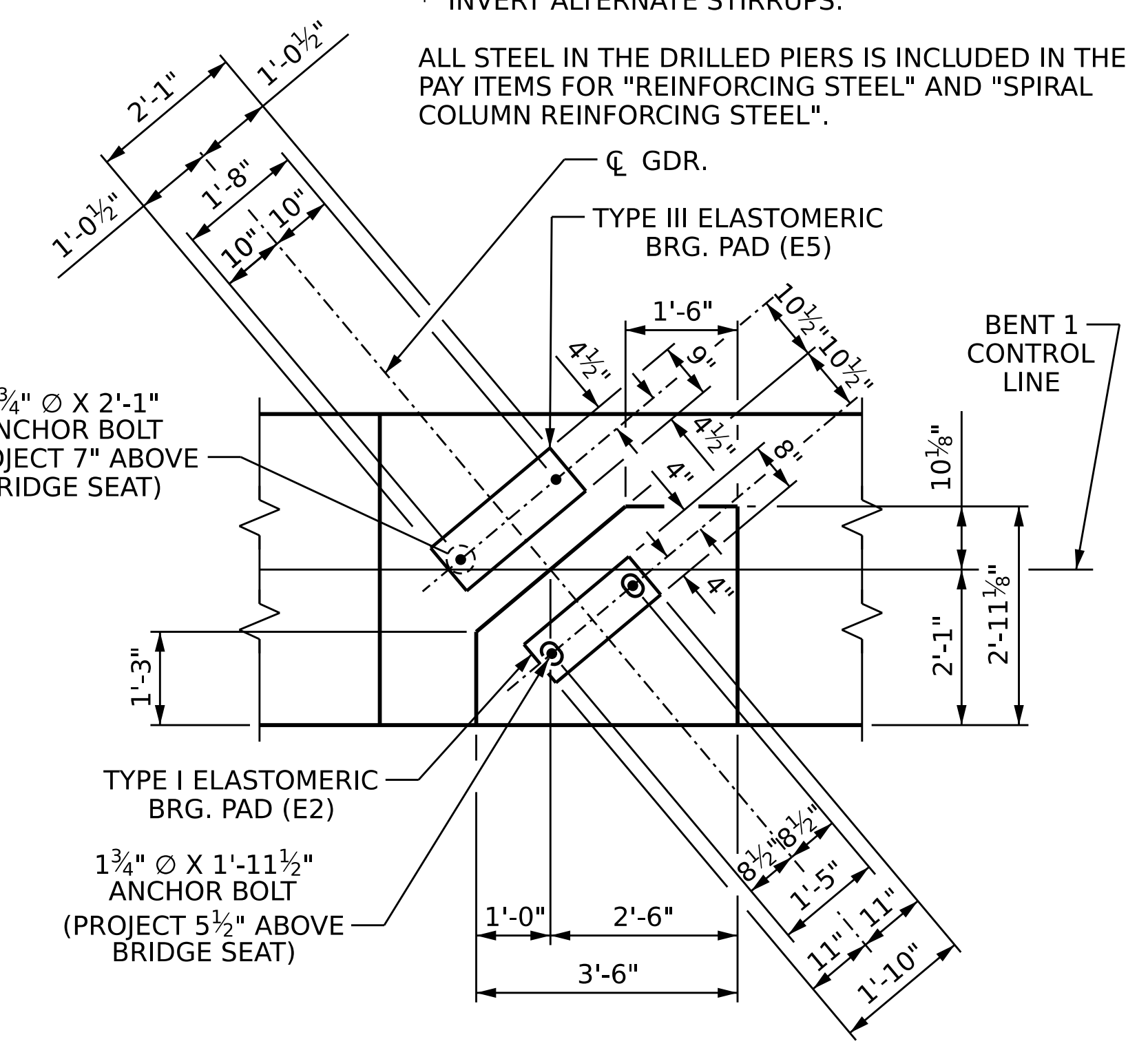
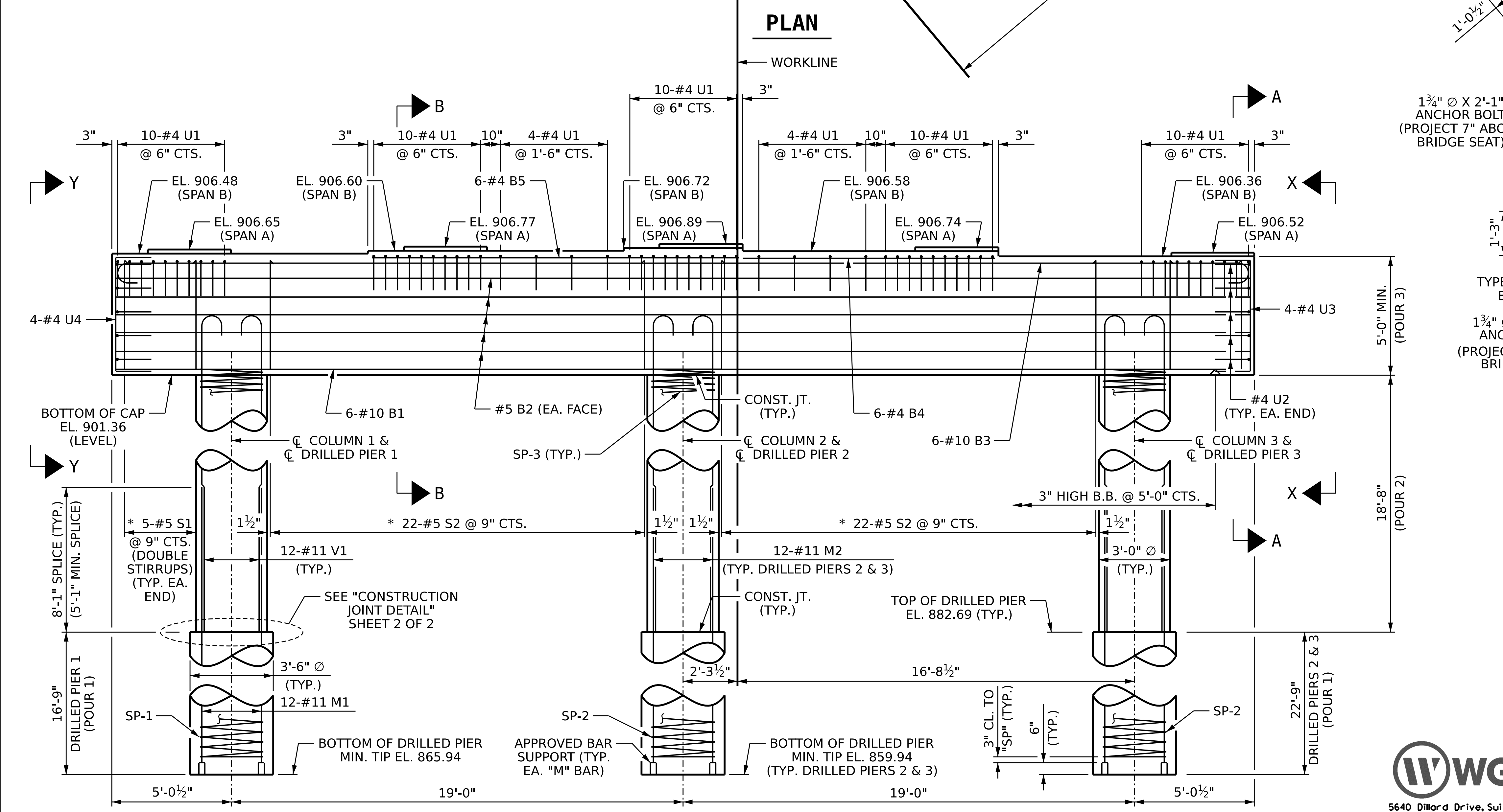

PROJECT NO. B-5783
DAVIDSON COUNTY
 STATION: 21+53.61 -SBL-

SHEET 1 OF 2

STATE OF NORTH CAROLINA
 DEPARTMENT OF TRANSPORTATION
 RALEIGH
 SUBSTRUCTURE

BENT 1

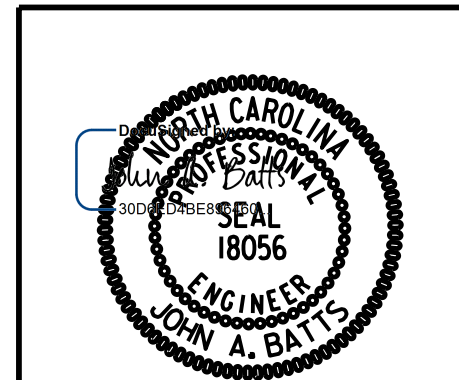

DRAWN BY: T. BANKOVICH DATE: 12-22
 CHECKED BY: J.A. BATTS DATE: 12-22
 DESIGN ENGINEER OF RECORD: J.A. BATTS DATE: 12-22

(DIMENSIONS & REINFORCING STEEL ARE TYPICAL FOR EACH COLUMN & DRILLED PIER UNLESS OTHERWISE NOTED)

REVISIONS				SHEET NO.	
NO.	BY:	DATE:	NO.	BY:	DATE:
1			3		
2			4		

DOCUMENT NOT CONSIDERED FINAL UNLESS ALL SIGNATURES COMPLETED

SHEET NO. S2-30
 TOTAL SHEETS 40