

3/21/2023 8:16:20 AM P:\Raleigh\Projects\2019\Division 9 (Davenport)\B-5783\Structures\Drawings\NEW\280168_SB\B-5783_SMU_BM_280168.dgn

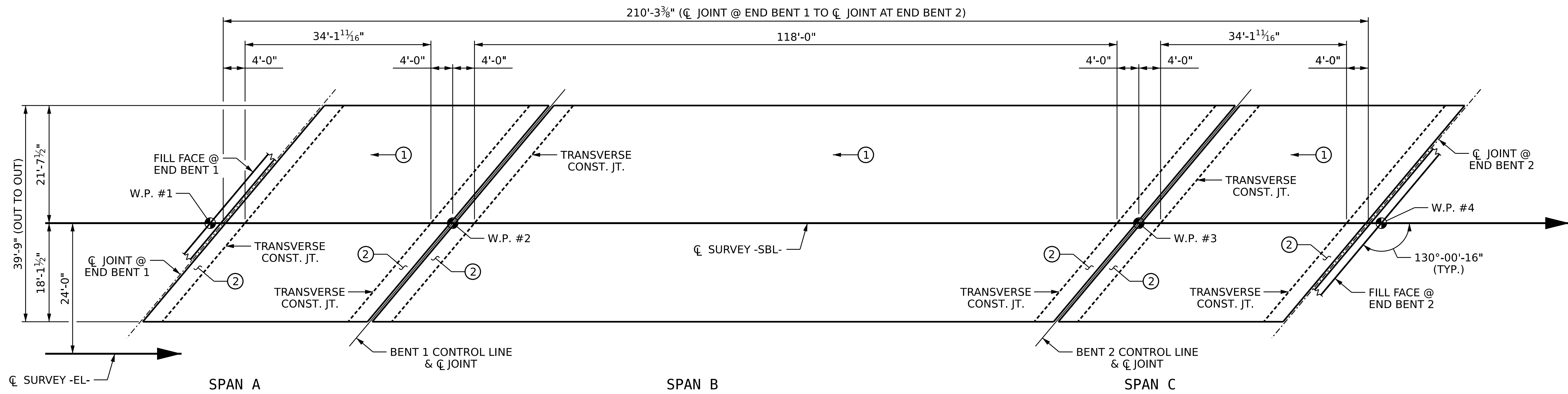

**POUR SEQUENCE AND LAYOUT FOR COMPUTING
REINFORCED CONCRETE DECK SLAB AREA**

(SQ. FT. 8,359)

← (#) INDICATES POUR NUMBER AND DIRECTION

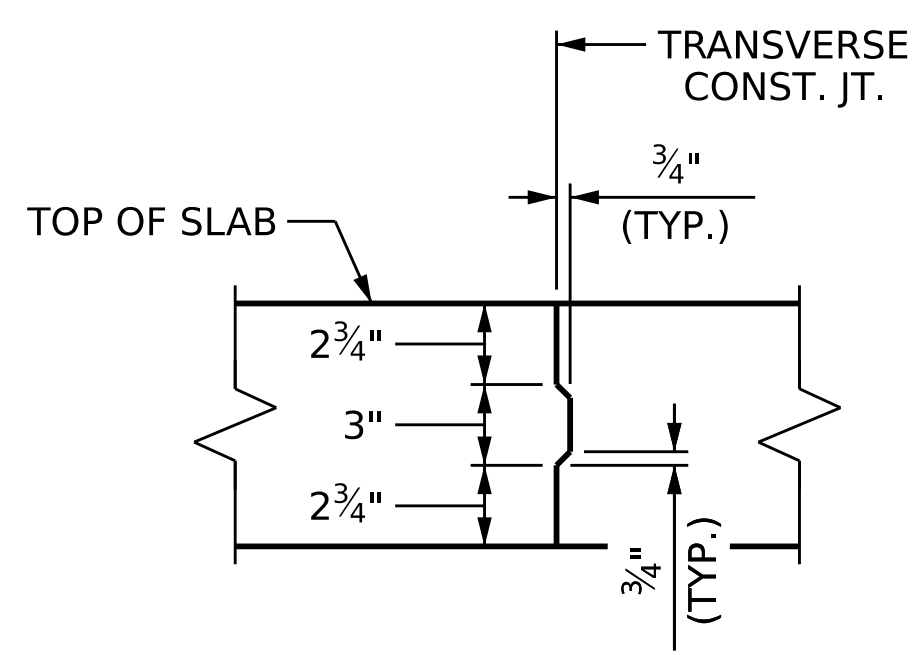

**TRANSVERSE CONSTRUCTION
JOINT DETAIL**

NOTE: REINFORCING STEEL IN SLAB NOT SHOWN.
LONGITUDINAL REINFORCING STEEL SHALL BE
CONTINUOUS THRU JOINT.

PROJECT NO. B-5783
DAVIDSON COUNTY
 STATION: 21+53.61 -SBL-

SHEET 1 OF 2

STATE OF NORTH CAROLINA
 DEPARTMENT OF TRANSPORTATION
 RALEIGH
 SUPERSTRUCTURE

BILL OF MATERIAL

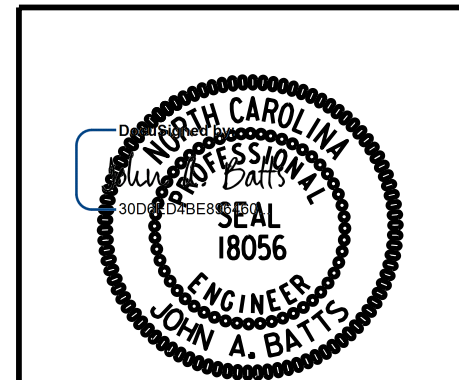

REVISIONS						SHEET NO.
NO.	BY:	DATE:	NO.	BY:	DATE:	S2-25
1			3			TOTAL SHEETS
2			4			40

DRAWN BY : T. BANKOVICH DATE : 12-22
 CHECKED BY : J.A. BATTS DATE : 12-22
 DESIGN ENGINEER OF RECORD: J.A. BATTS DATE : 12-22

**DOCUMENT NOT CONSIDERED FINAL
UNLESS ALL SIGNATURES COMPLETED**