

PROJECT REFERENCE NO. R-5930A	SHEET NO. 2D-1
R/W SHEET NO.	
ROADWAY DESIGN ENGINEER	HYDRAULICS ENGINEER
DOCUMENT NOT CONSIDERED FINAL UNLESS ALL SIGNATURES COMPLETED	

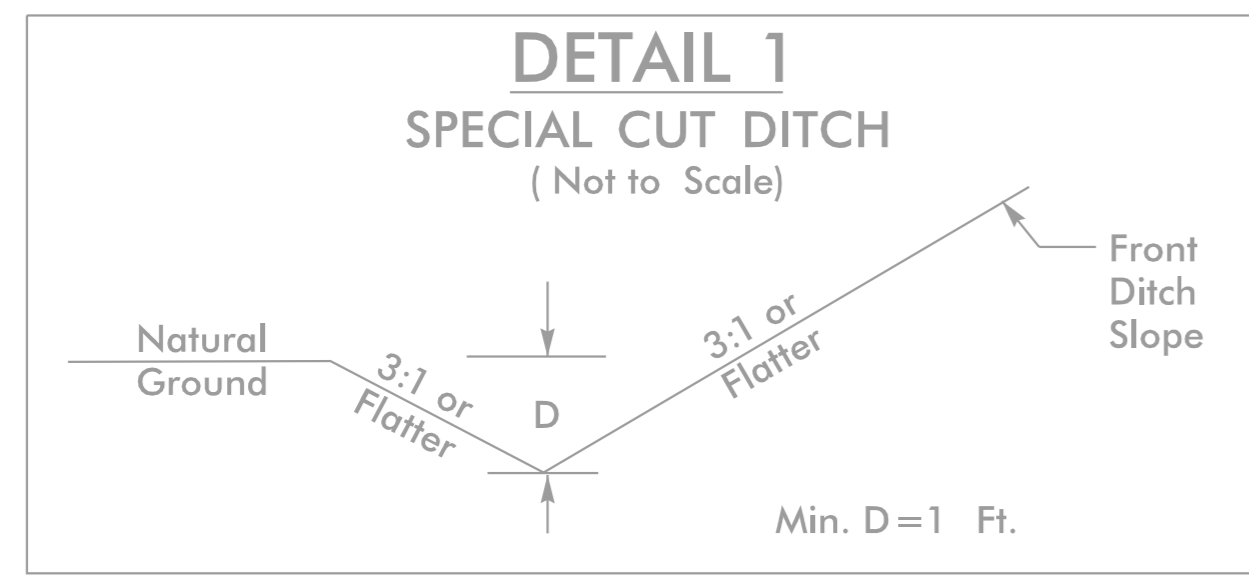

DETAIL APPLIES TO R-5930B (FUTURE)

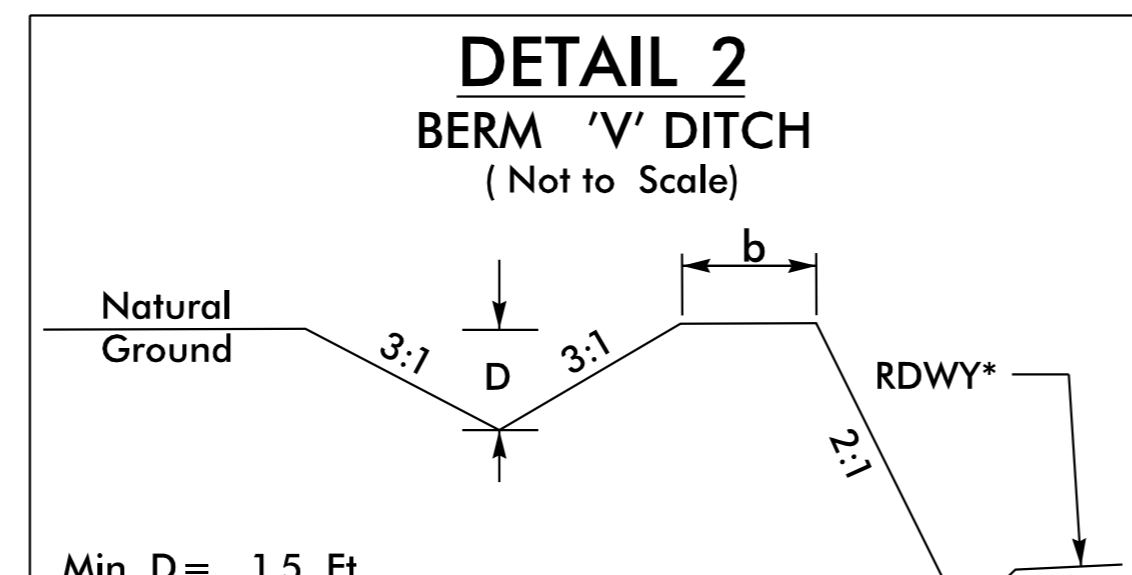

*RDWY or Cut Ditch. See Detail 7 where applicable

FROM STA. 42+70 TO STA. 49+40 -L- (LT)
FROM STA. 49+40 TO STA. 53+00 -L- (LT)
FROM STA. 85+00 TO STA. 87+00 -L- (RT)

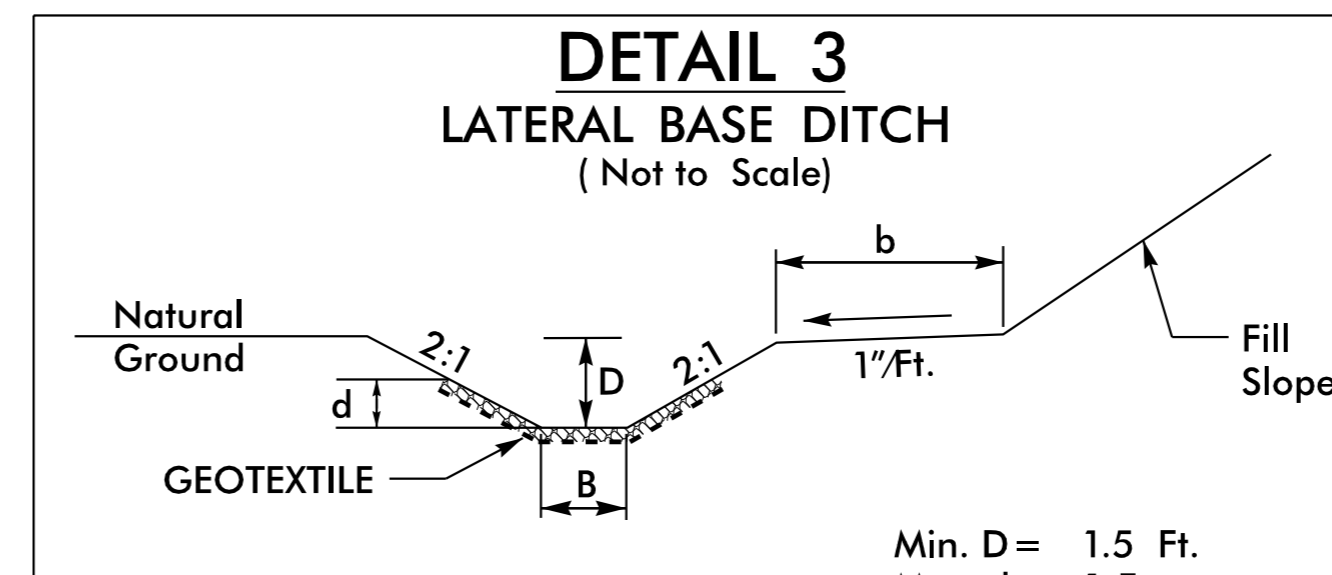

*When B is < 6.0'
Type of Liner=CL-I Rip-Rap

FROM STA. 68+50 TO STA. 70+00 -L- (RT)
FROM STA. 82+50 TO STA. 83+50 -L- (RT)

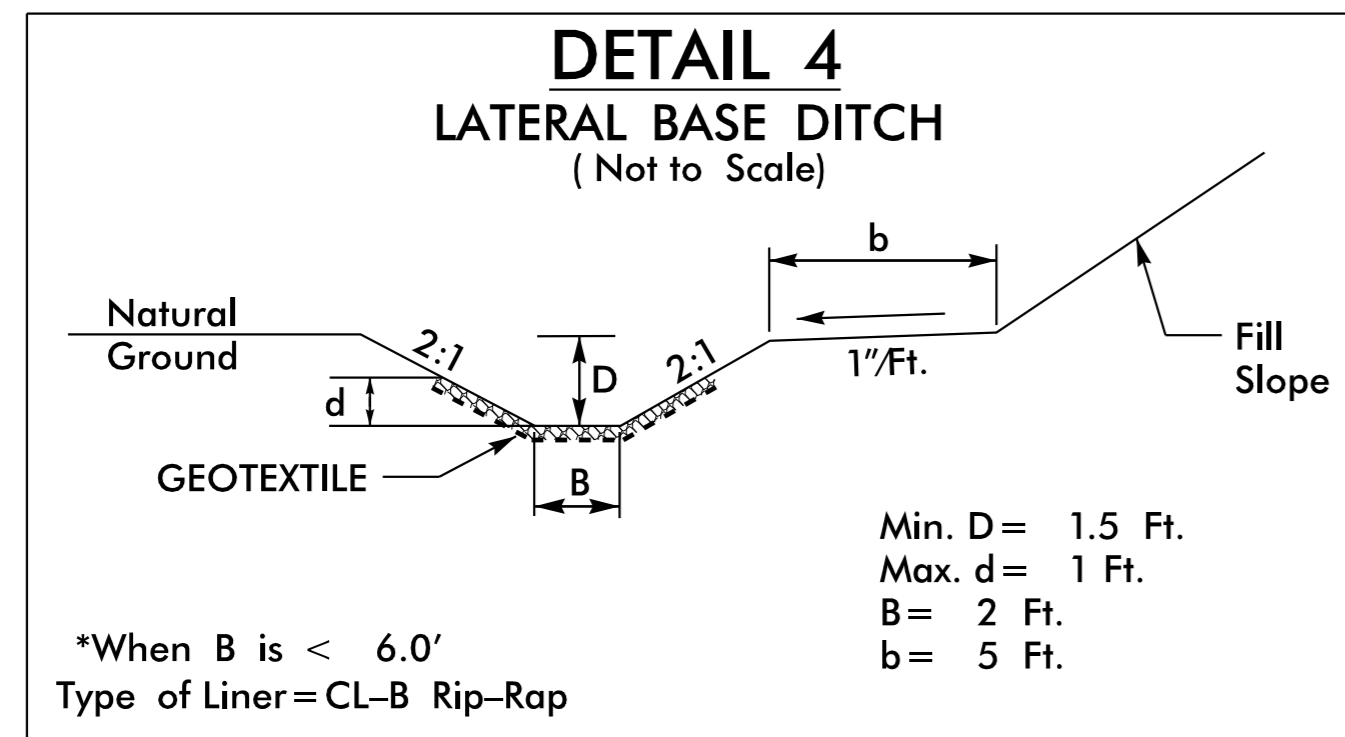

*When B is < 6.0'
Type of Liner=CL-B Rip-Rap

FROM STA. 70+00 TO STA. 71+50 -L- (RT)

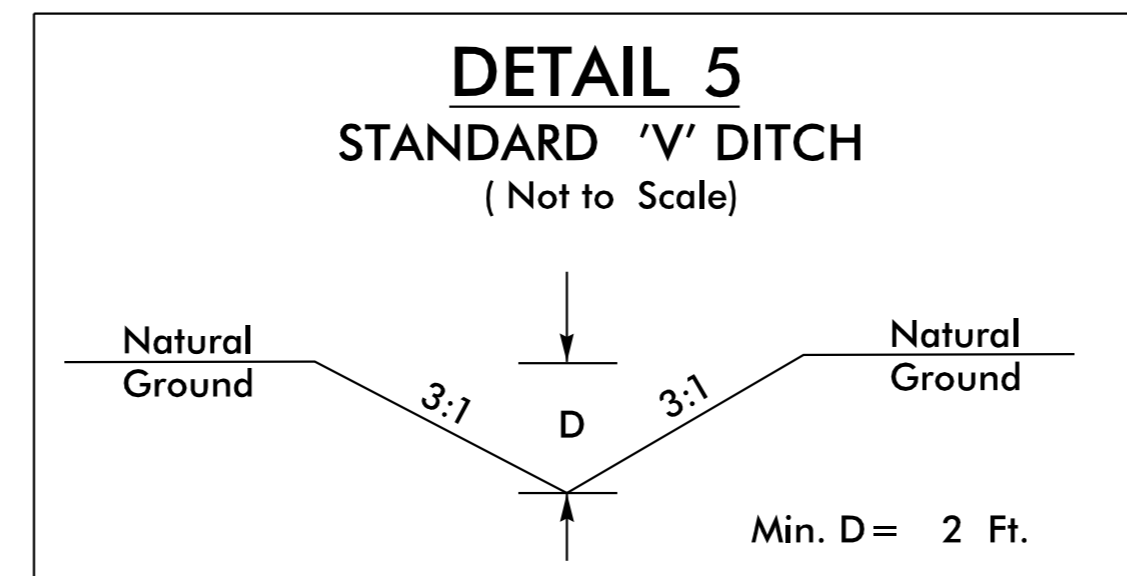

STA. 47+70 -L- (RT)

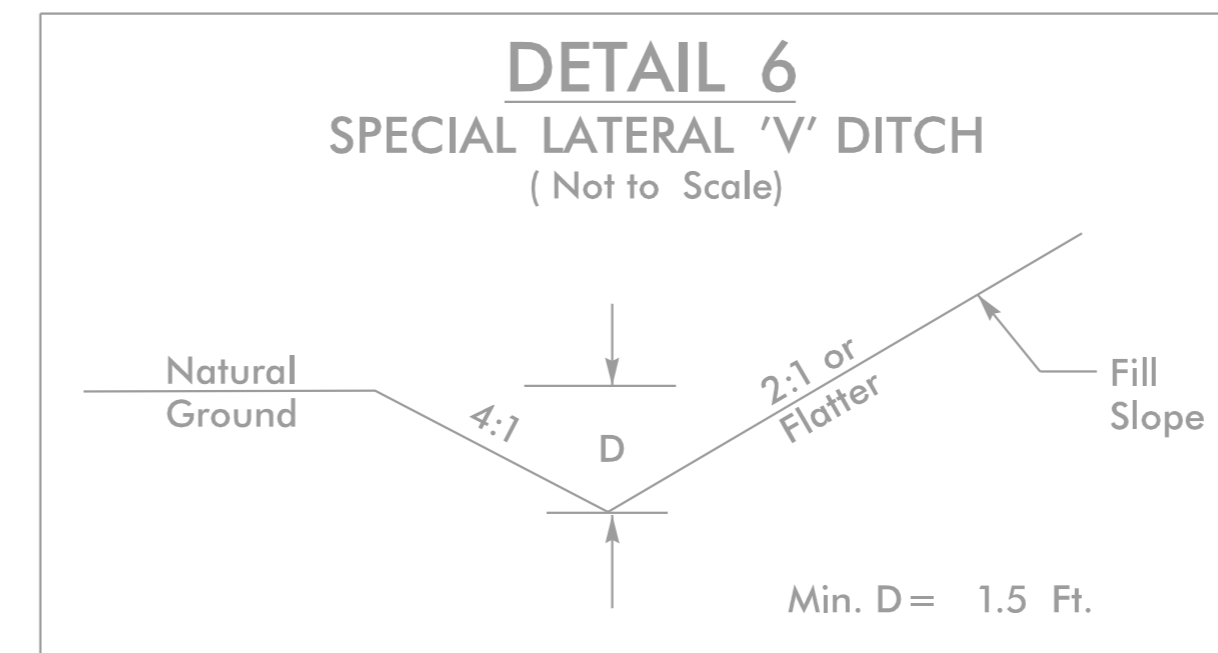

DETAIL APPLIES TO R-5930B (FUTURE)

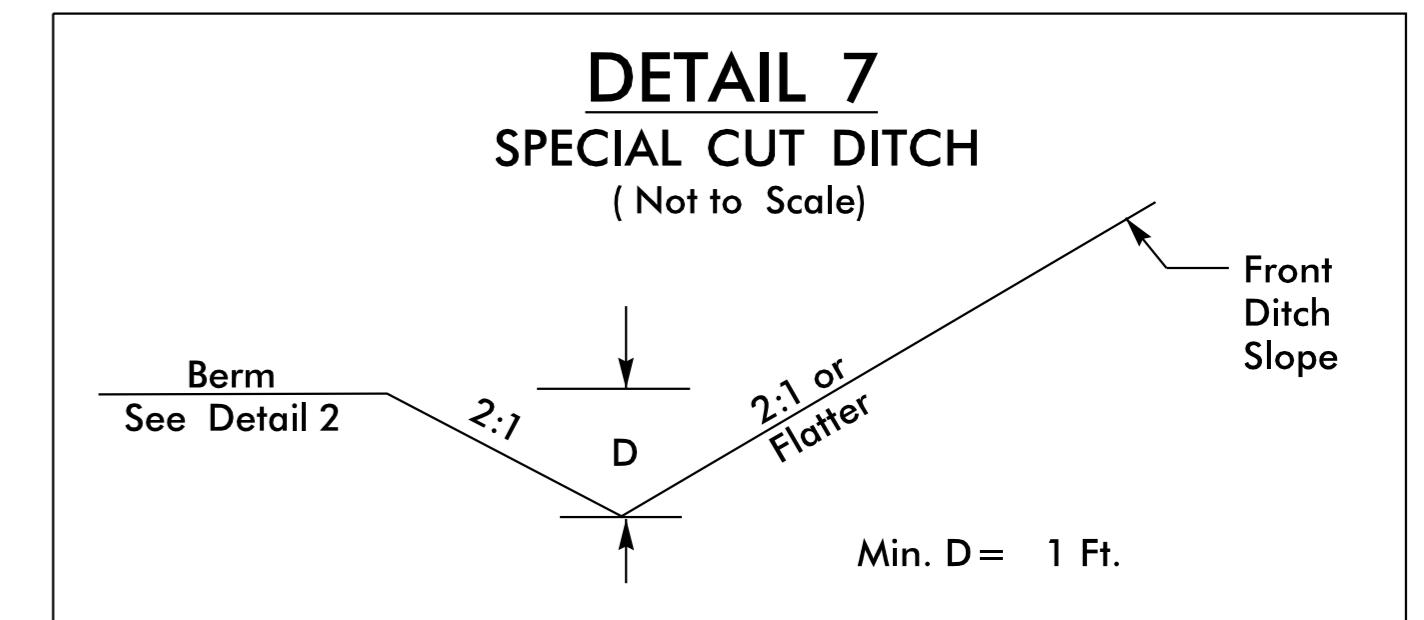

FROM STA. 42+70 TO STA. 48+90 -L- (LT)
FROM STA. 49+50 TO STA. 49+75 -L- (LT)
FROM STA. 49+75 TO STA. 51+75 -L- (LT)
FROM STA. 51+75 TO STA. 53+15 -L- (LT)

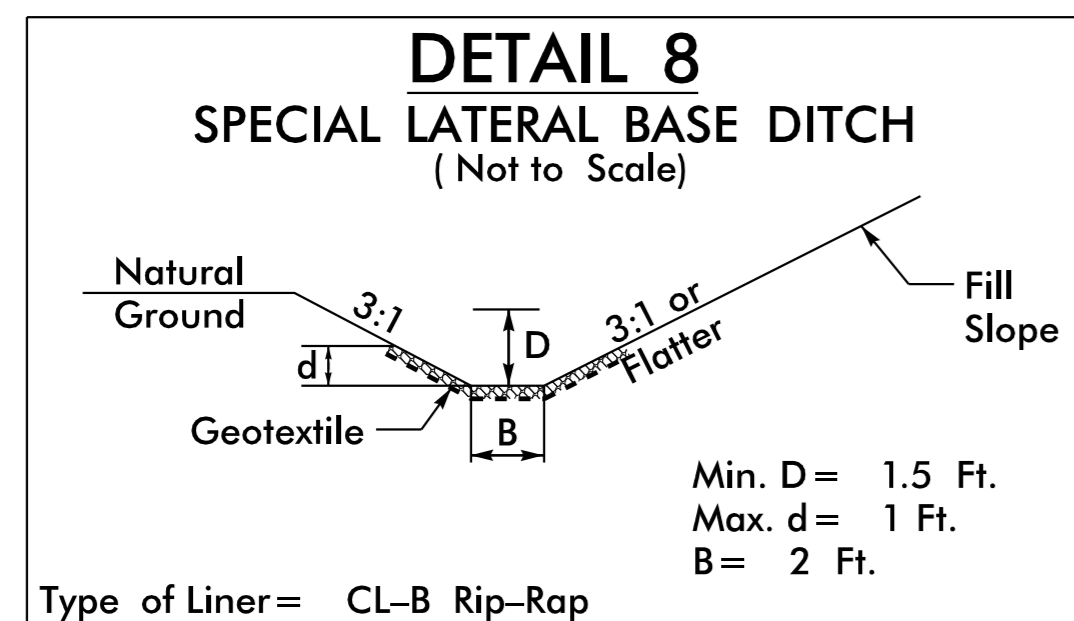

Type of Liner= CL-B Rip-Rap

FROM STA. 54+75 TO STA. 57+30 -L- (LT)

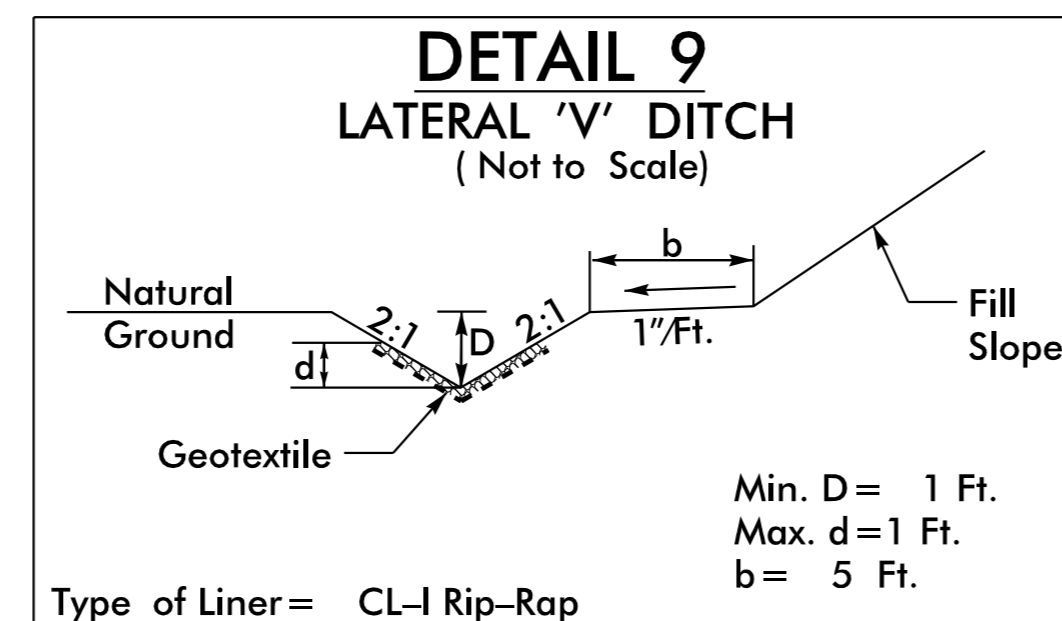

Type of Liner= CL-I Rip-Rap

FROM STA. 69+05 TO STA. 70+00 -L- (LT)
FROM STA. 70+00 TO STA. 71+50 -L- (LT)

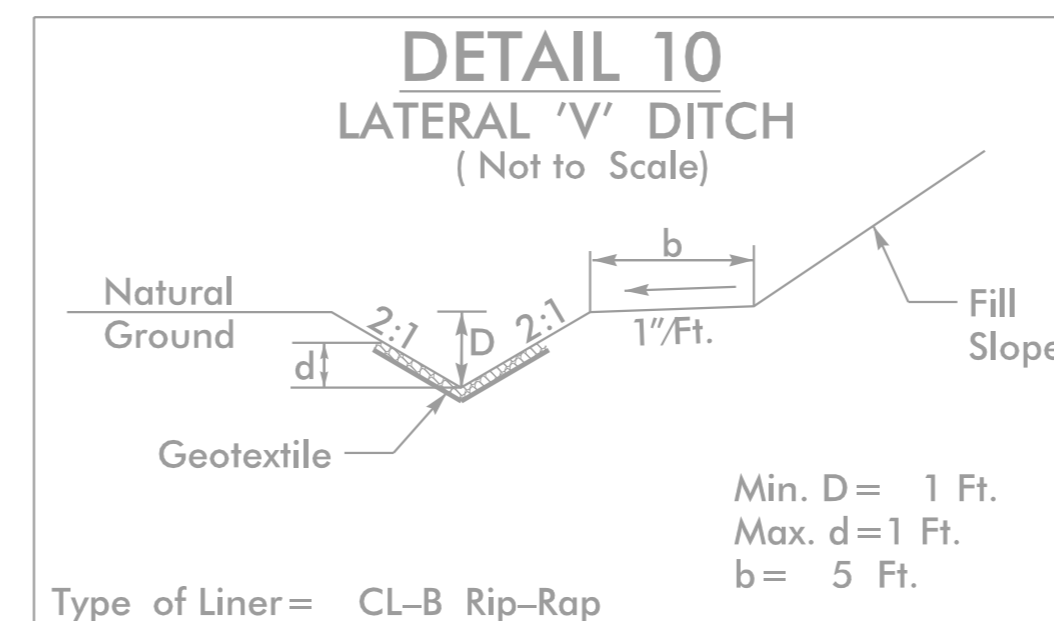

Type of Liner= CL-B Rip-Rap

DETAIL APPLIES TO R-5930B (FUTURE)

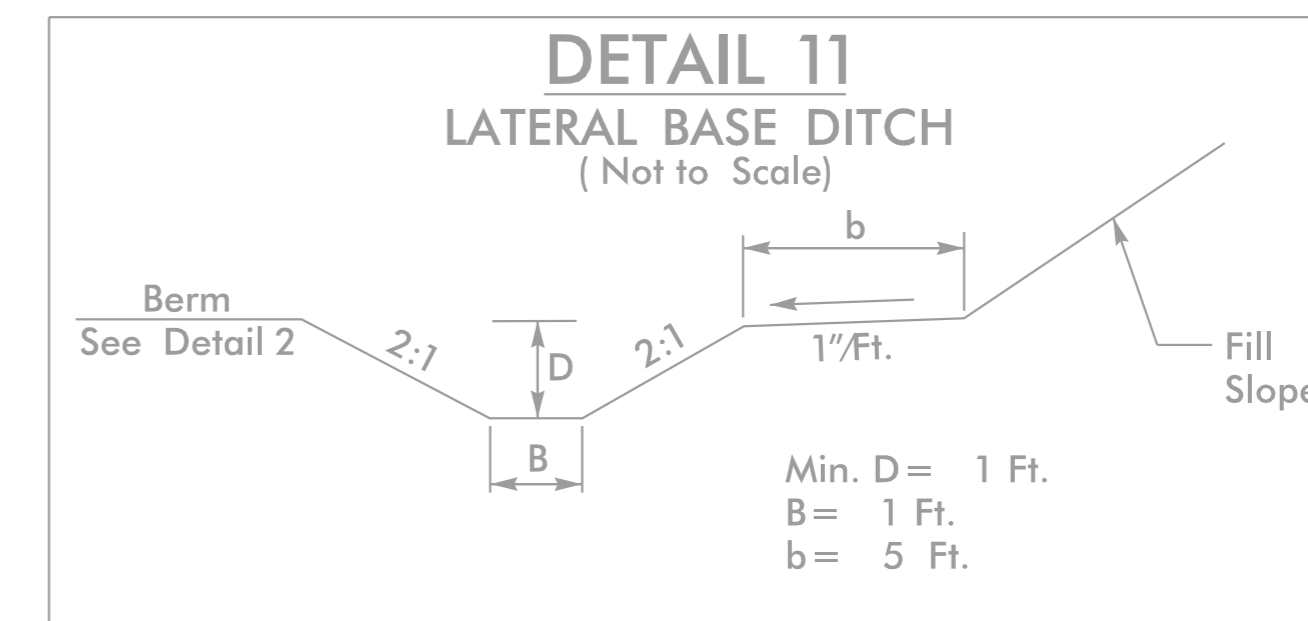

DETAIL APPLIES TO R-5930B (FUTURE)

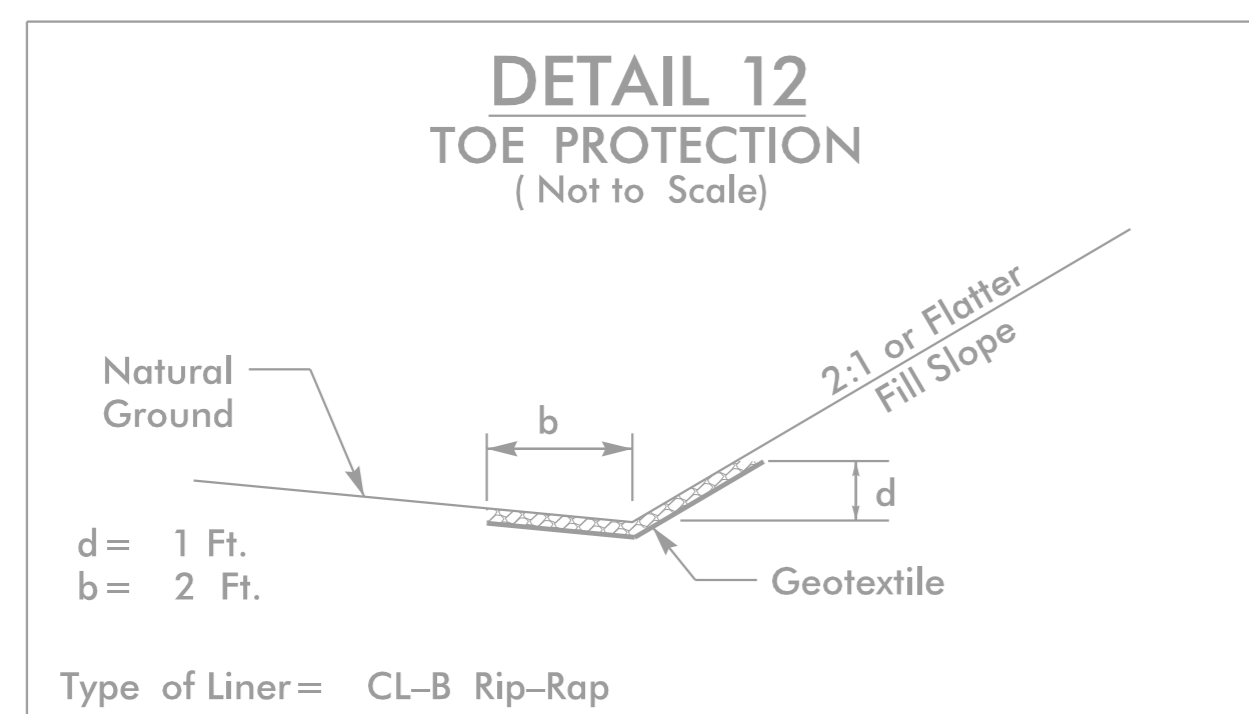

Type of Liner= CL-B Rip-Rap

DETAIL APPLIES TO R-5930B (FUTURE)

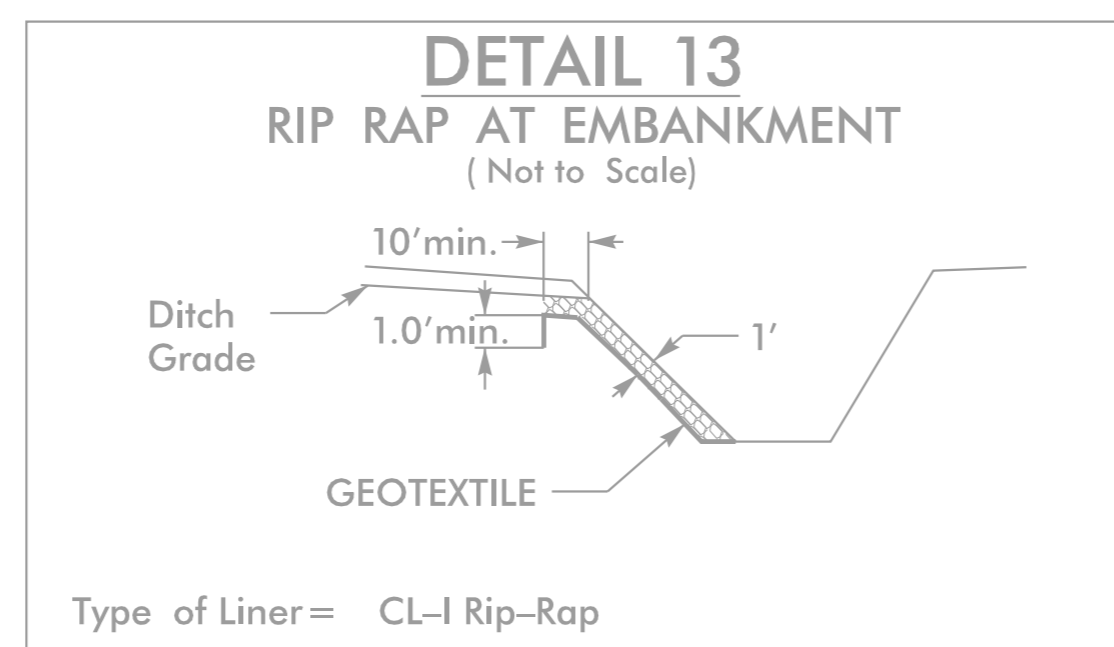

Type of Liner= CL-I Rip-Rap

DETAIL APPLIES TO R-5930B (FUTURE)

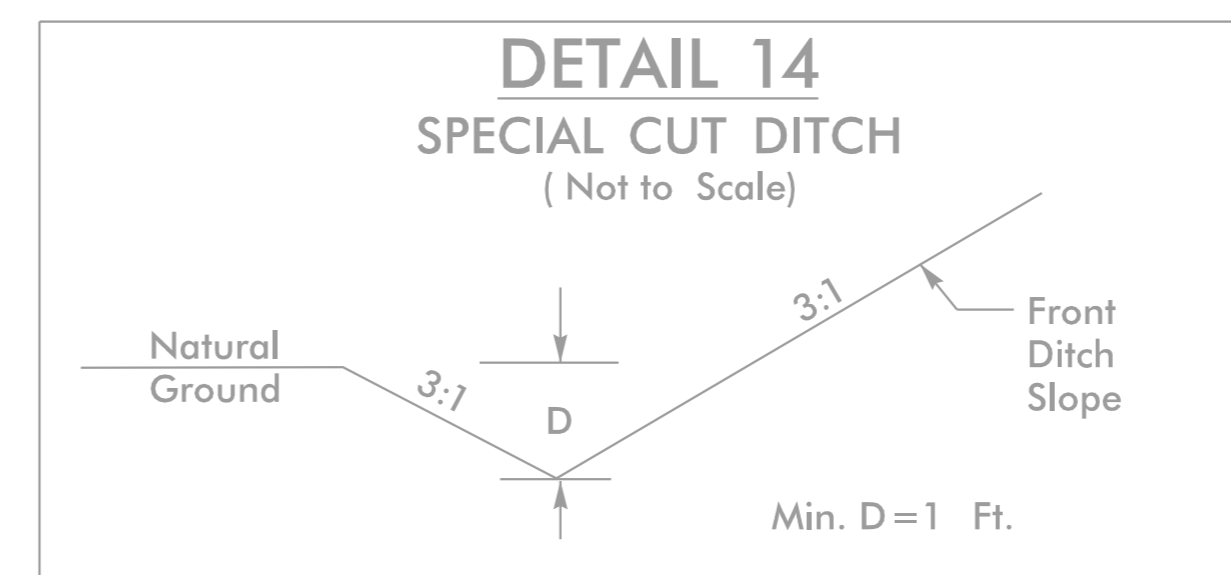

DETAIL APPLIES TO R-5930B (FUTURE)

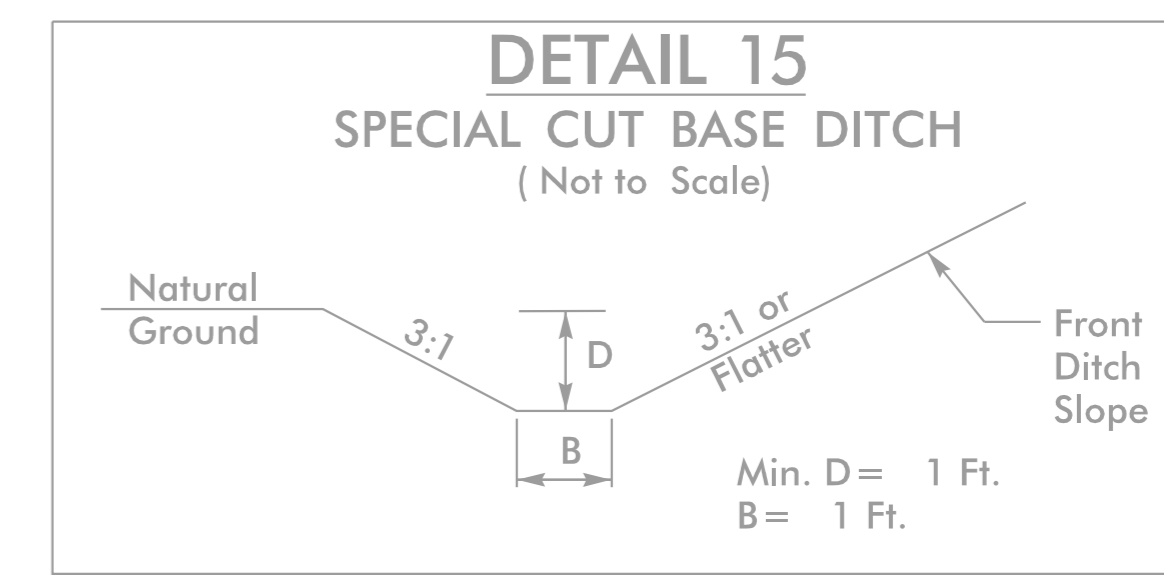

DETAIL APPLIES TO R-5930B (FUTURE)

K:\RAL_Roadway\01036532 - R-5930 North CPWA Roadway\Proj\R-5930A_rdy_psh_2D-1.dgn

REVISIONS