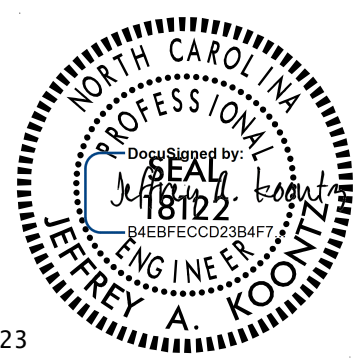

TIP NO.	SHEET NO.
U-5748	PMP-1
APPROVED: _____	
DATE: _____	
SEAL	
	
3/7/2023	
DOCUMENT NOT CONSIDERED FINAL UNLESS ALL SIGNATURES COMPLETED	

**STATE OF NORTH CAROLINA
DEPARTMENT OF TRANSPORTATION**

**PAVEMENT MARKING PLAN
WAKE COUNTY**

T.I.P.: U-5748

CONTRACT: C204786

INDEX

SHEET NO.	DESCRIPTION
PMP-1	PAVEMENT MARKING PLAN TITLE AND SCHEDULE SHEET
PMP-2-15	PAVEMENT MARKING DETAIL

PAVEMENT MARKING SCHEDULE

SYMBOL	DESCRIPTION
T1	WHITE EDGELINE (4" 90 MIL)
T2	WHITE SOLID LANE LINE (4" 90 MIL)
T3	10 FT. WHITE SKIP (4" 90 MIL)
T4	3 FT. - 9 FT./SP WHITE MINISKIP (4" 90 MIL)
T5	2 FT. - 6 FT./SP WHITE MINISKIP (4" 90 MIL)
T10	YELLOW EDGELINE (4" 90 MIL)
T11	YELLOW SINGLE CENTER (4" 90 MIL)
T13	YELLOW DOUBLE CENTER (4" 90 MIL)
T14	2 FT. - 6 FT./SP YELLOW MINISKIP (4" 90 MIL)
T40	WHITE GORELINE (8" 90 MIL)
T41	WHITE DIAGONAL (8" 90 MIL)
T43	WHITE SOLID LANE LINE (8" 90 MIL)
T44	3 FT. - 9 FT./SP WHITE MINISKIP (8" 90 MIL)
T46	WHITE CROSSWALK LINE (8" 90 MIL)
T51	WHITE DIAGONAL (12" 90 MIL)
T52	YELLOW DIAGONAL (12" 90 MIL)
T61	WHITE STOPBAR (24" 90 MIL)
T62	WHITE CROSSWALK LINE (24" 90 MIL)
T70	LEFT TURN ARROW (90 MIL)
T71	RIGHT TURN ARROW (90 MIL)
T72	STRAIGHT ARROW (90 MIL)
T74	COMBO. RIGHT/STRAIGHT ARROW (90 MIL)
T77	U-TURN ARROW (90 MIL)
T78	COMBO. LEFT/U-TURN ARROW (90 MIL)
T79	MERGE ARROW (90 MIL)
T90	BICYCLE SYMBOL, HEATED-IN-PLACE (90 MIL)
T91	BICYCLE STRAIGHT ARROW, HEATED-IN-PLACE (90 MIL)
T100	ALPHANUMERIC CHAR. (90 MIL)
T103	24" YIELD LINE TRIANGLE (90 MIL)
C1	WHITE EDGELINE (4")
C3	10FT. WHITE SKIP (4")
C4	3 FT. - 9 FT./SP WHITE MINISKIP (4")
C10	YELLOW EDGELINE (4")
C79	MERGE ARROW

GENERAL NOTES

- THE FOLLOWING GENERAL NOTES APPLY AT ALL TIMES FOR THE DURATION OF THE CONSTRUCTION PROJECT, EXCEPT WHEN OTHERWISE NOTED IN THE PLAN, OR DIRECTED BY THE ENGINEER.
- A) INSTALL PAVEMENT MARKINGS AND PAVEMENT MARKERS ON THE FINAL SURFACE AS FOLLOWS:

ROAD NAME	MARKING	MARKER
US 401 (LOUISBURG RD)	THERMOPLASTIC	SNOWPLOWABLE
US 401 (BRIDGE)	COLD APPLIED PLASTIC	RAISED
SR 2224 (MITCHELL MILL RD)	THERMOPLASTIC	RAISED
SR 2044 (LIGON MILL RD)	THERMOPLASTIC	RAISED
 - B) TIE PROPOSED PAVEMENT MARKING LINES TO EXISTING PAVEMENT MARKING LINES.
 - C) REMOVE/REPLACE ANY CONFLICTING/DAMAGED PAVEMENT MARKINGS AND MARKERS.
 - D) STOP BAR LOCATION AT NON-SIGNALIZED INTERSECTIONS MAY BE ADJUSTED AS DIRECTED BY THE ENGINEER.
 - E) REMOVE ALL RESIDUE AND SURFACE LAITANCE BY ACCEPTABLE METHODS ON CONCRETE BRIDGE DECKS PRIOR TO PLACING COLD APPLIED PLASTIC PAVEMENT MARKING MATERIAL.
 - F) UNLESS OTHERWISE SPECIFIED, HEATED-IN-PLACE THERMOPLASTIC MAY BE USED IN LIEU OF EXTRUDED THERMOPLASTIC FOR STOP BARS, SYMBOLS, CHARACTERS AND DIAGONALS. IF HEATED-IN-PLACE IS USED, IT SHALL BE PAID FOR USING THE EXTRUDED THERMOPLASTIC PAY ITEM.
 - G) ALL BICYCLE LANE SYMBOLS SHALL BE HEATED-IN-PLACE THERMOPLASTIC. SYMBOLS SHALL BE PAID FOR USING THE HEATED-IN-PLACE PAY ITEM.

ROADWAY STANDARD DRAWING

THE FOLLOWING ROADWAY STANDARDS AS APPEAR IN "ROADWAY STANDARD DRAWINGS" - PROJECT SERVICES UNIT - N.C. DEPARTMENT OF TRANSPORTATION - RALEIGH, N.C., DATED JANUARY 2018 ARE APPLICABLE TO THIS PROJECT AND BY REFERENCE HEREBY ARE CONSIDERED A PART OF THESE PLANS:

STD. NO.	TITLE
1205.01	PAVEMENT MARKINGS - LINE TYPES AND OFFSETS
1205.02	PAVEMENT MARKINGS - TWO-LANE AND MULTILANE ROADWAYS
1205.04	PAVEMENT MARKINGS - INTERSECTIONS
1205.05	PAVEMENT MARKINGS - TURN LANES
1205.06	PAVEMENT MARKINGS - LANE DROPS
1205.07	PAVEMENT MARKINGS - PEDESTRIAN CROSSWALKS
1205.08	PAVEMENT MARKINGS - SYMBOLS AND WORD MESSAGES
1205.09	PAVEMENT MARKINGS - PAINTED ISLANDS
1205.15	PAVEMENT MARKINGS - SUPERSTREETS
1250.01	RAISED PAVEMENT MARKERS - INSTALLATION SPACING
1251.01	RAISED PAVEMENT MARKERS - PERMANENT AND TEMPORARY
1253.01	RAISED PAVEMENT MARKERS - SNOWPLOWABLE

PLAN SUBMITTED TO:

JOHN CONFORTI, P.E.
NCDOT PROJECT ENGINEER

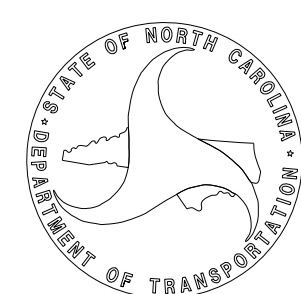

PLAN PREPARED BY: AECOM

JEFFREY KOONTZ, P.E. PROJECT ENGINEER
PATRICK MCPHERSON, E.I. PROJECT DESIGN ENGINEER

AECOM

NC FIRM LICENSE No: F-0342
5438 Wade Park Blvd,
Suite 200 Raleigh, NC 27607
(919) 854-6200 - (919) 854-6259(FAX)

TIP NO.	SHEET NO.
U-5748	PMP-2
APPROVED: _____	
DATE: _____	
SEAL	
3/7/2023	
DOCUMENT NOT CONSIDERED FINAL UNLESS ALL SIGNATURES COMPLETED	

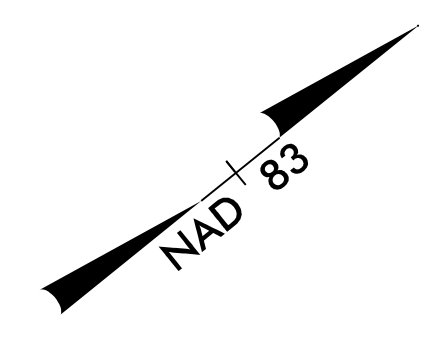

15

20

25

BEGIN TIP PROJECT U-5748
 END PAVEMENT MARKING
 PERRY CREEK RD SECTION
 TIE TO EXISTING
 -L- STA 15+50.00 SBL

T2 -L- STA 17+69 +/-

T70

T3

-L- STA 20+90 +/- T4

T79

T4

T1

C4

C10

C1

C79

C3

T1

T3

US 401 SB/LOUISBURG RD

US 401 NB/LOUISBURG RD

CAT-1 GREU 350, TL-3

-L- STA 14+11 +/- T2

END PAVEMENT MARKING
 PERRY CREEK RD SECTION
 TIE TO EXISTING
 -L- STA 17+90.00 NBL

-L- STA 18+10 +/- T4

-L- STA 19+60 +/- T3

BEGIN BRIDGE
 -L- STA 23+38 +/-

END BRIDGE
 -L- STA 26+38 +/-

T4 -L- STA 26+99 +/-

SEE SHEET PMP-3
 MATCHLINE -L- STA. 27 + 50.00

PAVEMENT MARKING DETAIL

I://2023
 p:\1\loc\com-nc-pw\ben\tiesy.com\AECOM_DS21.NA_2020\Documents\60609754-U-5748 Ligon MII\900-CAD GIS\910-CAD\70-NC\DOT_TIP\Traffic\PMU\U5748_pmp_psh02.dgn
 PST\ick\m\p\er\son

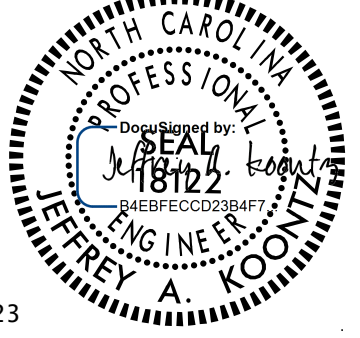
TIP NO.	SHEET NO.
U-5748	PMP-3
APPROVED:	
DATE:	
SEAL	
	3/7/2023
DOCUMENT NOT CONSIDERED FINAL UNLESS ALL SIGNATURES COMPLETED	

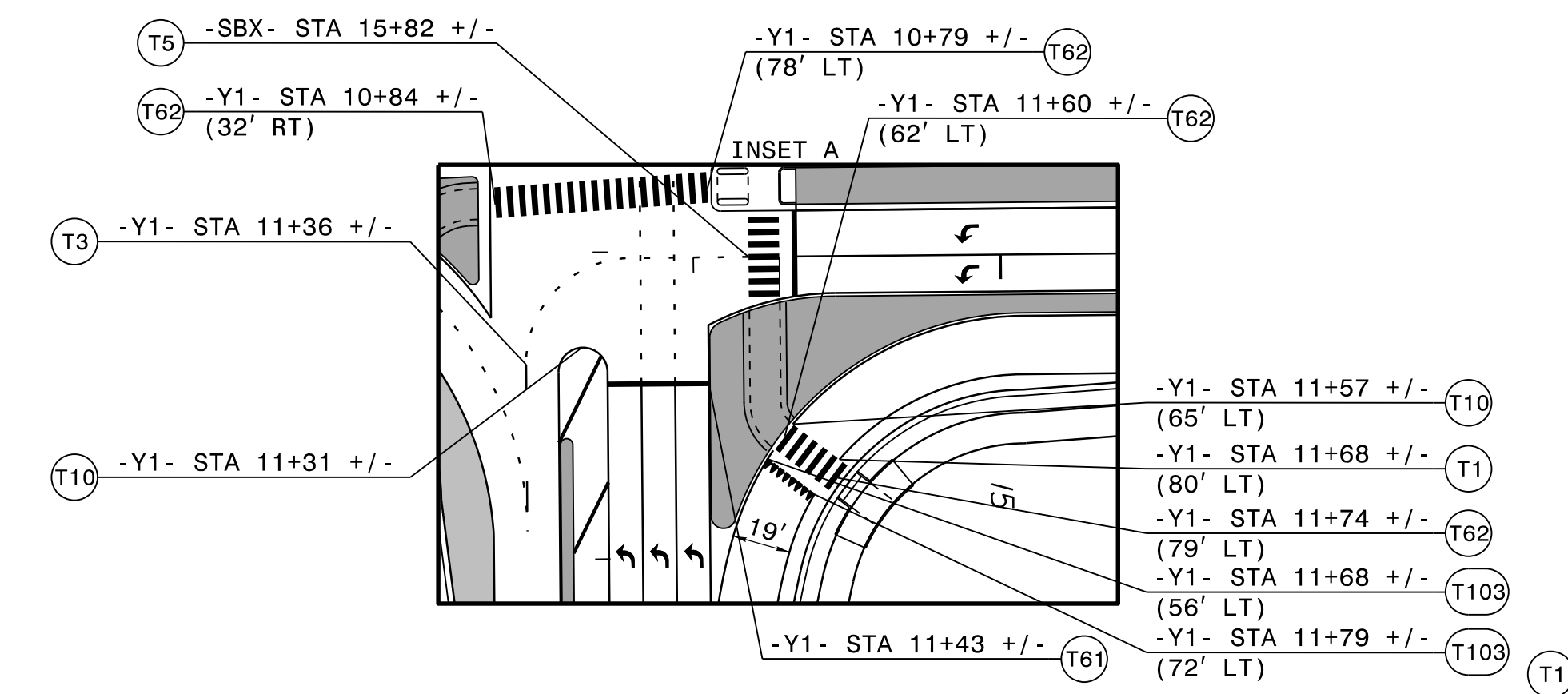
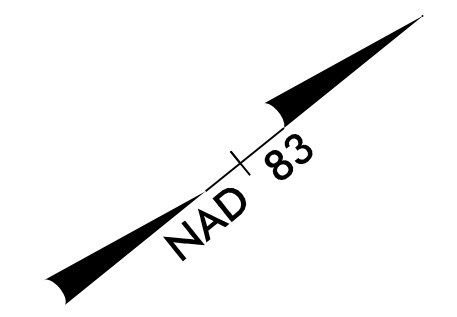

- CURB RAMP LOCATIONS**
- 1 -L- 32+88 +/- 122' RT (T3)
 - 2 -L- 33+32 +/- 84' RT (T.I. CUT THROUGH)
 - 3 -L- 34+16 +/- 73' LT (T3)
 - 4 -L- 34+16 +/- 23' LT (M.I. CR)
 - 5 -L- 34+25 +/- 23' RT (M.I. CR)
 - 6 -L- 34+25 +/- 71' RT (M.I. CUT THROUGH)
 - 7 -L- 34+25 +/- 118' RT (M.I. CUT THROUGH)
 - 8 -L- 34+51 +/- 176' RT (T3)

SEE SHEET PMP-2
MATCHLINE -L- STA. 27 + 50.00

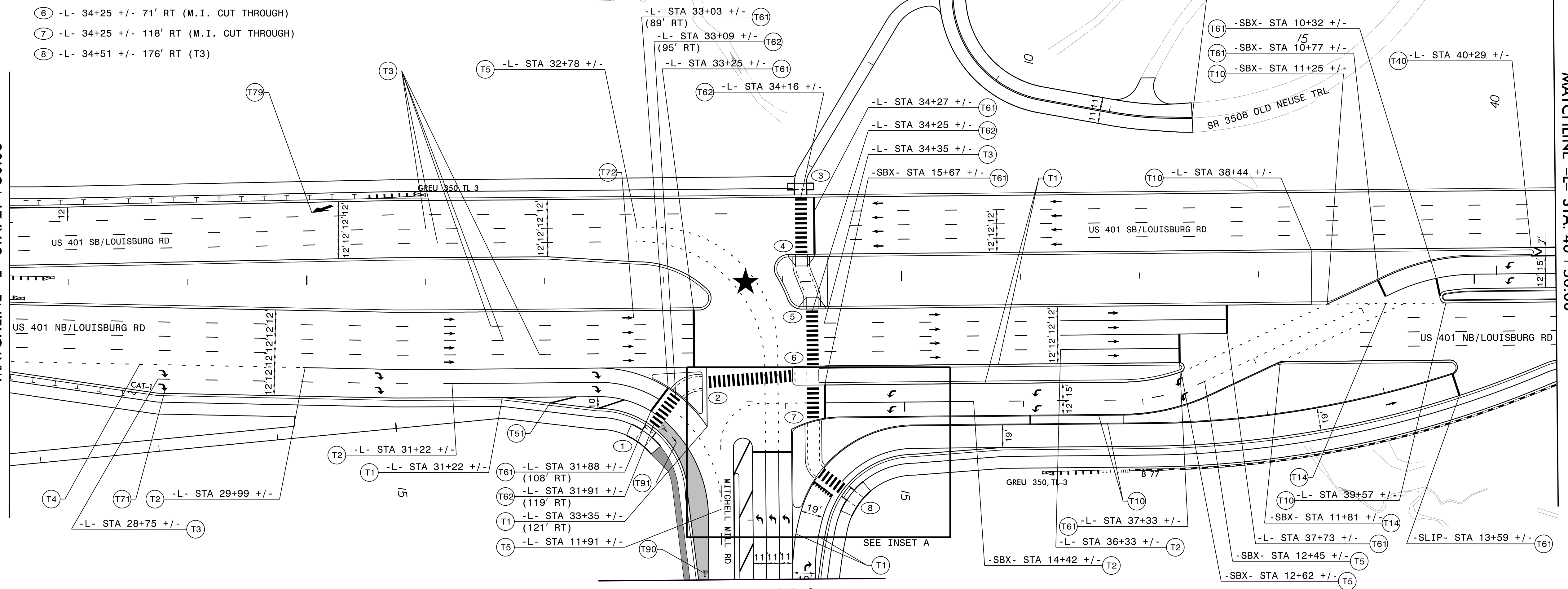

SEE SHEET PMP-8
MATCHLINE -Y1- STA 12 + 50.00

SEE SHEET PMP-4
MATCHLINE -L- STA. 40 + 50.00



PAVEMENT MARKING DETAIL

I://2023
 p:\w\1\cecom-nc-pw\benhety.com\ecom_DS21.NA_2020\Documents\60609754-U-5748 Ligon MII\900-CAD GIS\910-CAD\70-NC DOT_TIP\Traffic\PM\U5748_pmp-psn03.dgn
 DST\Fickler\peter.son

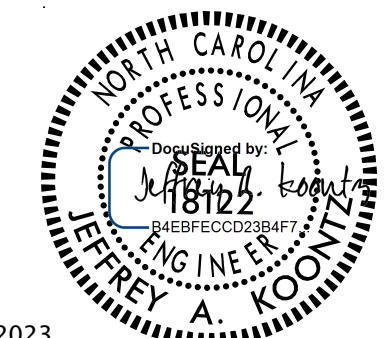
TIP NO.	SHEET NO.
U-5748	PMP-4
APPROVED: _____	
DATE: _____	
SEAL	
	
3/7/2023	
DOCUMENT NOT CONSIDERED FINAL UNLESS ALL SIGNATURES COMPLETED	

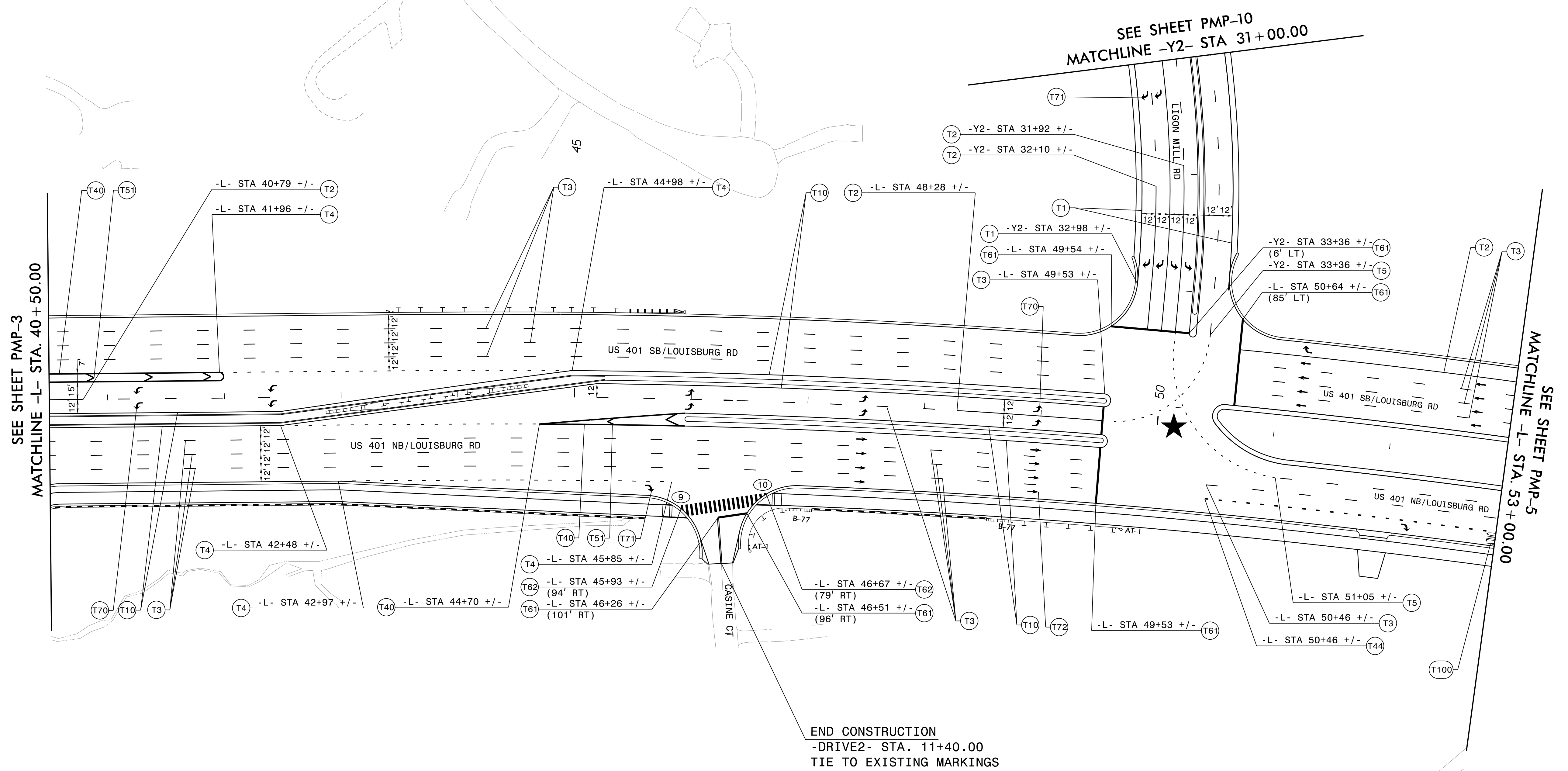
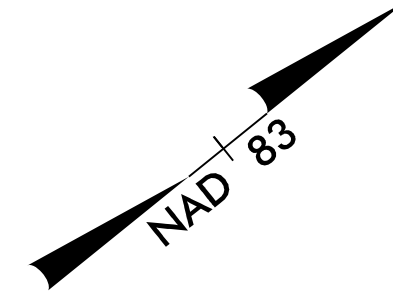

SEE SHEET PMP-3
MATCHLINE -L- STA. 40 + 50.00

SEE SHEET PMP-10
MATCHLINE -Y2- STA 31+00.00

SEE SHEET PMP-5
MATCHLINE -L- STA. 53 + 00.00

- CURB RAMP LOCATIONS**
- ⑨ -L- 45+92 +/- 96' RT (T1)
 - ⑩ -L- 46+66 +/- 83' RT (T1)

★ PROPOSED SIGNAL

PAVEMENT MARKING DETAIL

I://2023
 p:\1\loc.com-nc-pw-bentley.com\AECOM_DS21.NA_2020\Documents\60609754-U-5748 Ligon Mill\900-CAD GIS\900-CAD\70-NC DOT_TIP\Traffic\PM\U5748_pmp-dsh04.dgn
 DST\Fickler\peter.son

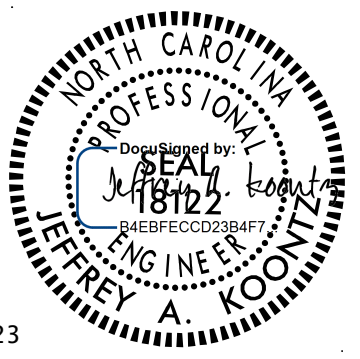
TIP NO.	SHEET NO.
U-5748	PMP-5
APPROVED: _____	
DATE: _____	
SEAL	
	
3/7/2023	
DOCUMENT NOT CONSIDERED FINAL UNLESS ALL SIGNATURES COMPLETED	

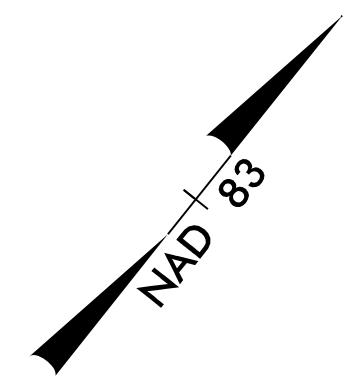

- CURB RAMP LOCATIONS**
- (11) -L- 58+07 +/- 82' RT (T1)
 - (12) -L- 58+87 +/- 71' RT (T1)

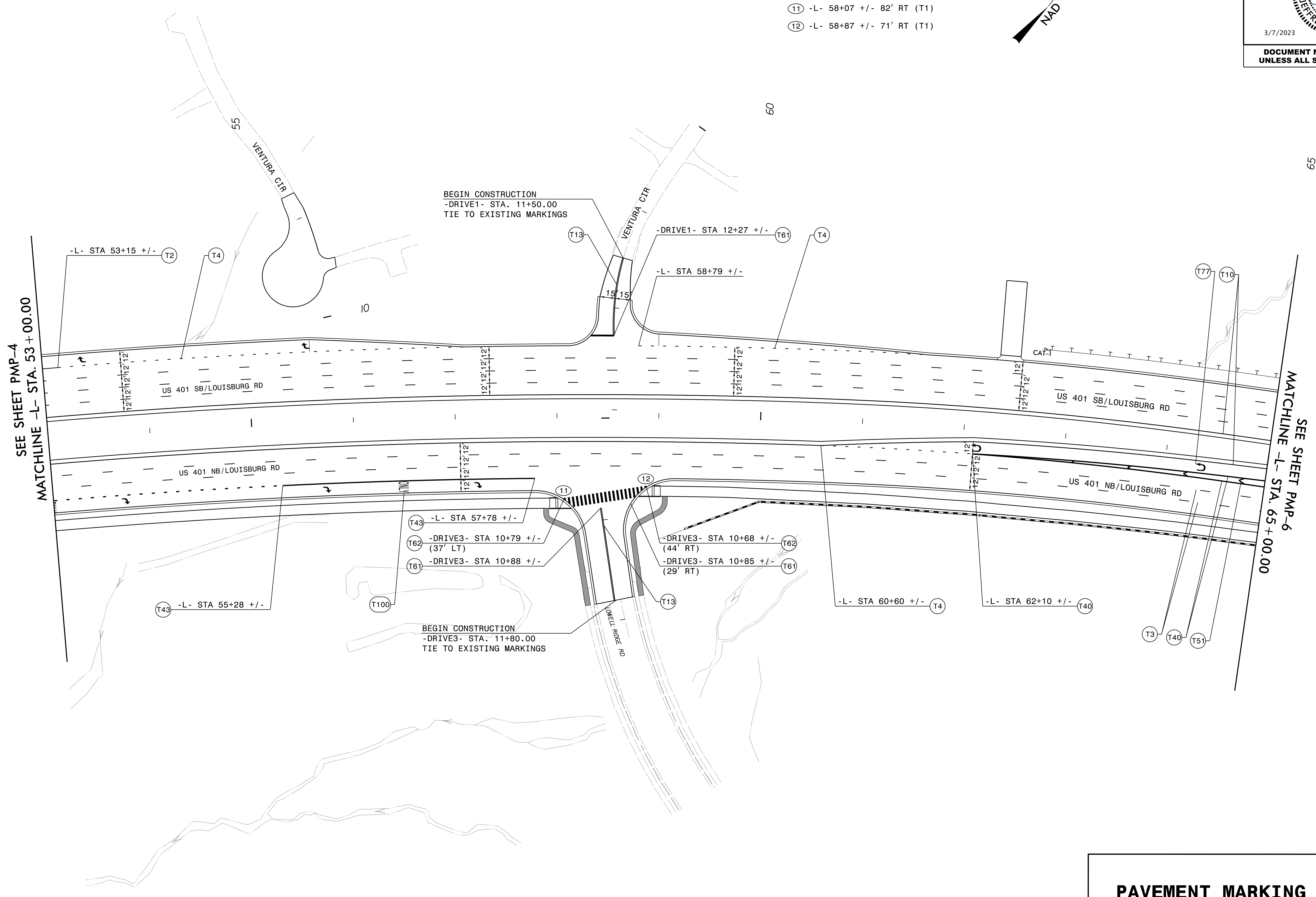

PAVEMENT MARKING DETAIL

I://2023
 p:\1\loc.com-nc-pw.bentley.com\ecom\ds21\na_2020\Documents\60609754-U-5748 Ligon MI\900-CAD GIS\910-CAD\70-NC DOT_TIP\Traffic\PM\U5748_pmp-dsh05.dgn
 DSTTICK.mcd\pnt.son

TIP NO.	SHEET NO.
U-5748	PMP-6
APPROVED: _____	
DATE: _____	
SEAL	
3/7/2023	
DOCUMENT NOT CONSIDERED FINAL UNLESS ALL SIGNATURES COMPLETED	

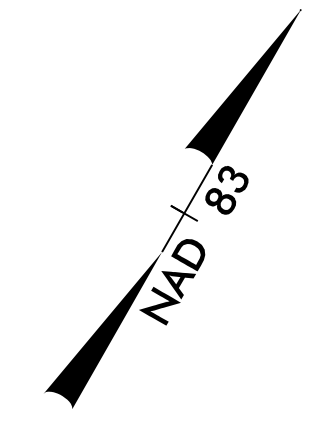

- CURB RAMP LOCATIONS**
- ⑬ -L- 75+02 +/- 71' RT (T1)
 - ⑭ -L- 75+49 +/- 71' RT (T1)

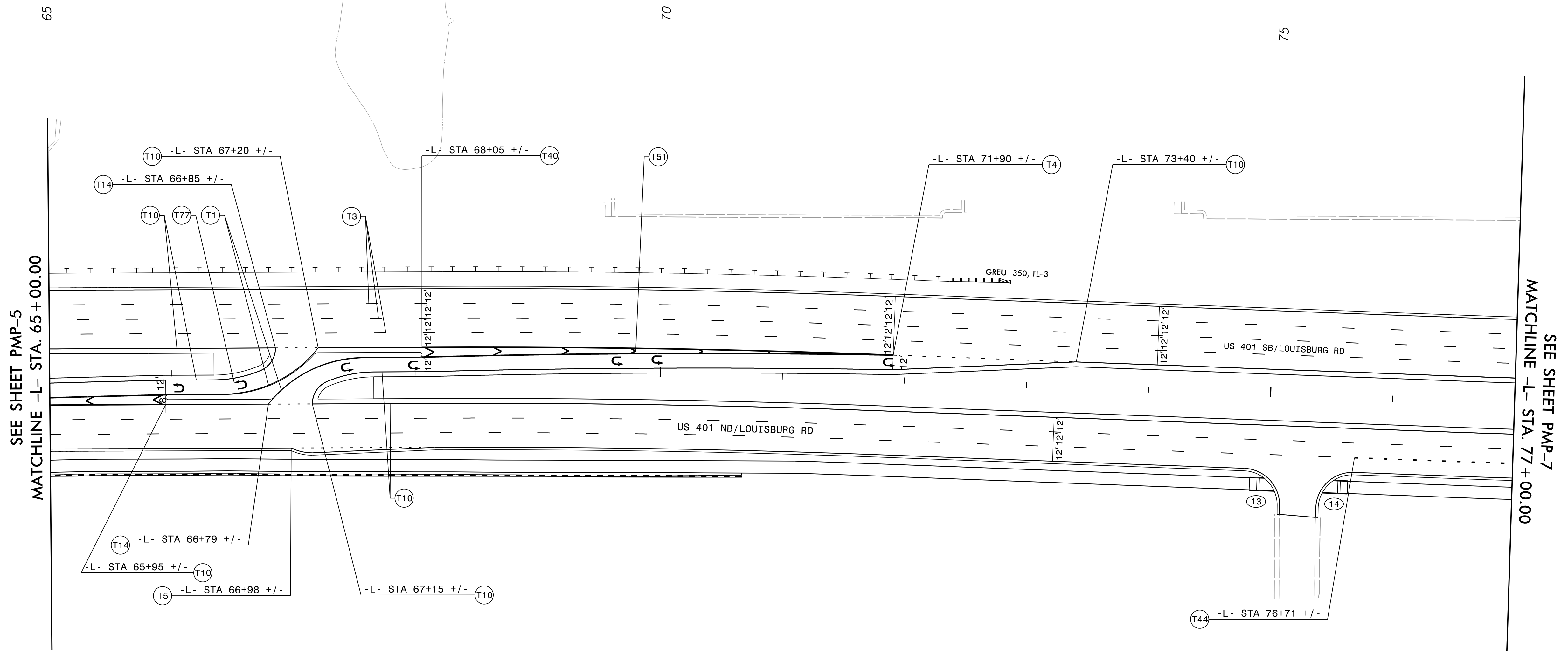

PAVEMENT MARKING DETAIL

I/1/2023
 p:\1\geocom-mc-pw-bentley.com\AECOM\DS2\NA_2020\Documents\60609754-U-5748 Ligon MI\1900-CAD GIS\910-CAD\70-NCDDOT_TIP\Traffic\PM\U5748_pmp.psh06.dgn
 POST: lck.mcdpeter@son

TIP NO.	SHEET NO.
U-5748	PMP-7
APPROVED: _____	
DATE: _____	
SEAL	
3/7/2023	
DOCUMENT NOT CONSIDERED FINAL UNLESS ALL SIGNATURES COMPLETED	

- CURB RAMP LOCATIONS**
- ⑭ -L- 85+00 +/- 67' RT (STD)
 - ⑮ -L- 85+11 +/- 80' RT (STD)

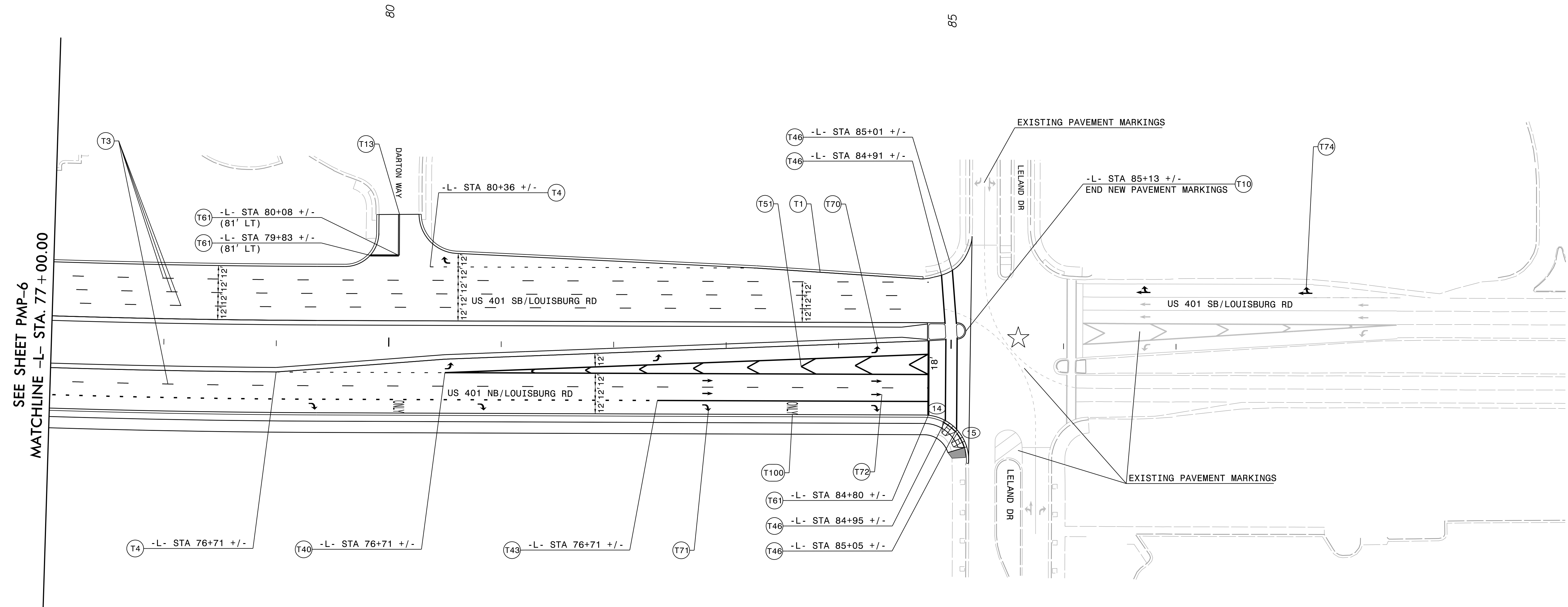
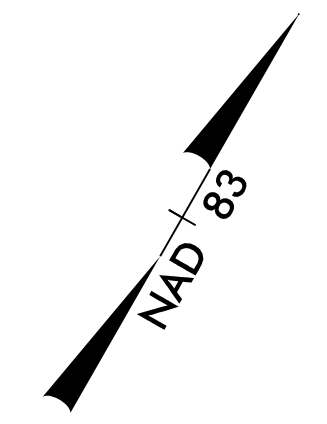

SEE SHEET PMP-6
MATCHLINE -L- STA. 77+00.00



PAVEMENT MARKING DETAIL

1/11/2023
 p:\1\geocom-mc-pw-bentley.com\AECOM\Documents\60609754-U-5748-Ligon-MH\900-CAD-GS\910-CAD\70-NC\DOT-TIP\Traffic\PM\U5748_pmp.psh07.dgn
 PBT\ick.mcd\peter.son

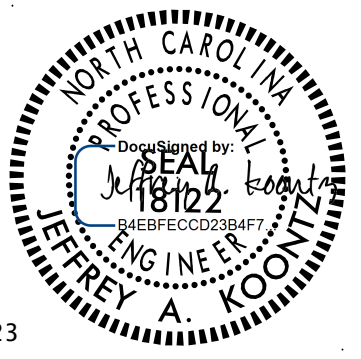
TIP NO.	SHEET NO.
U-5748	PMP-8
APPROVED:	_____
DATE:	_____
SEAL	
	3/7/2023
DOCUMENT NOT CONSIDERED FINAL UNLESS ALL SIGNATURES COMPLETED	

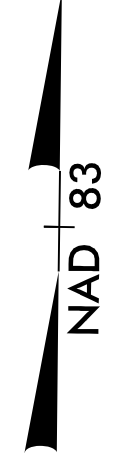

25

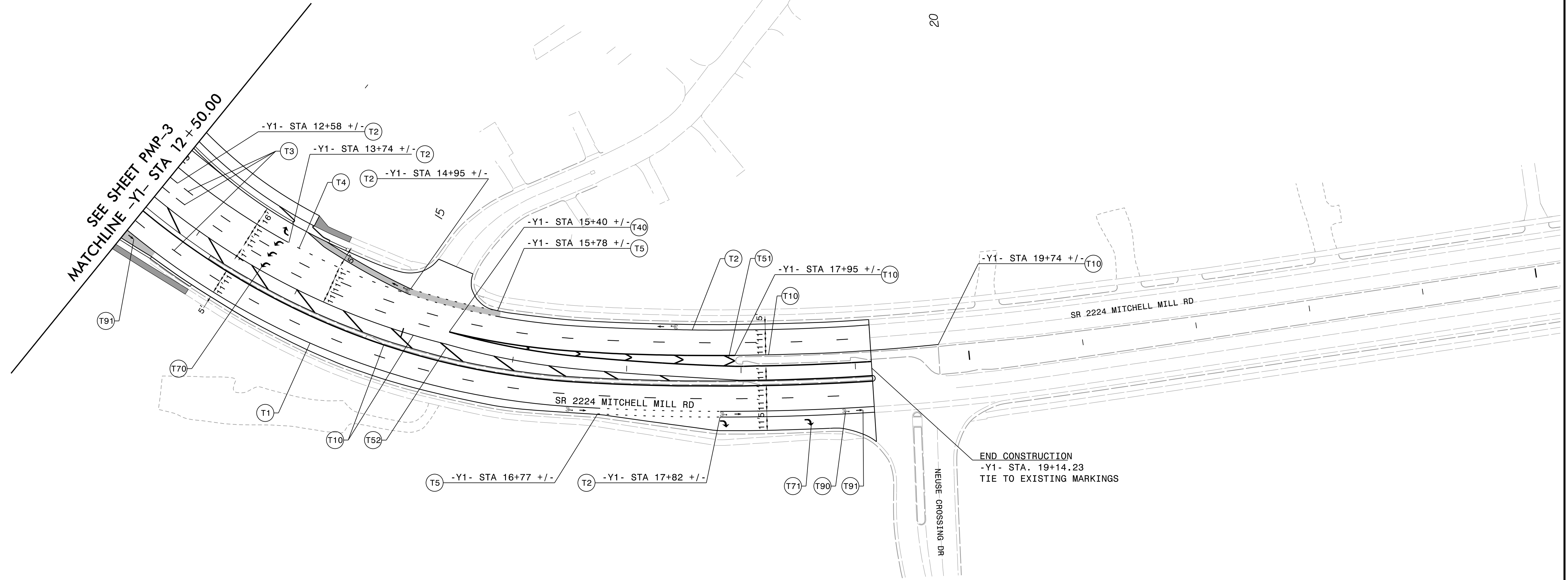

I/11/2023
 p:\w\l\gecom-mc-pw-bentley.com\AECOM\Documents\60609754-U-5748 Ligon MI\900-CAD_GIS\910-CAD\70-NC\DOT_TIP\Traffic\PM\U5748_pmp.pst\pmp.pst\pmp.pst\pmp.pst
 POST: lck.mcdpeter@son

PAVEMENT MARKING DETAIL

TIP NO.	SHEET NO.
U-5748	PMP-9
APPROVED: _____	
DATE: _____	
SEAL	
	
3/7/2023	
DOCUMENT NOT CONSIDERED FINAL UNLESS ALL SIGNATURES COMPLETED	

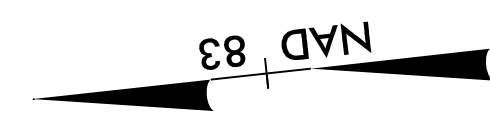

BEGIN CONSTRUCTION
-Y2- STA. 12+00.00
TIE TO EXISTING MARKINGS

BEGIN CONSTRUCTION
-Y3- STA. 11+00.00
TIE TO EXISTING MARKINGS

MATCHLINE SEE SHEET PMP-10
-Y2- STA 22+00.00

PAVEMENT MARKING DETAIL

1/11/2023
 p:\w\l\cecom-mc-pw-bentley.com\AECOM\DS2\INA_2020\Documents\60609754-U-5748 Ligon Mill\900-CAD_05\910-CAD\70-NCDOT_TIP\Traffic\PM\U5748_pmp.psh09.dgn
 POST: lck.mcpherson

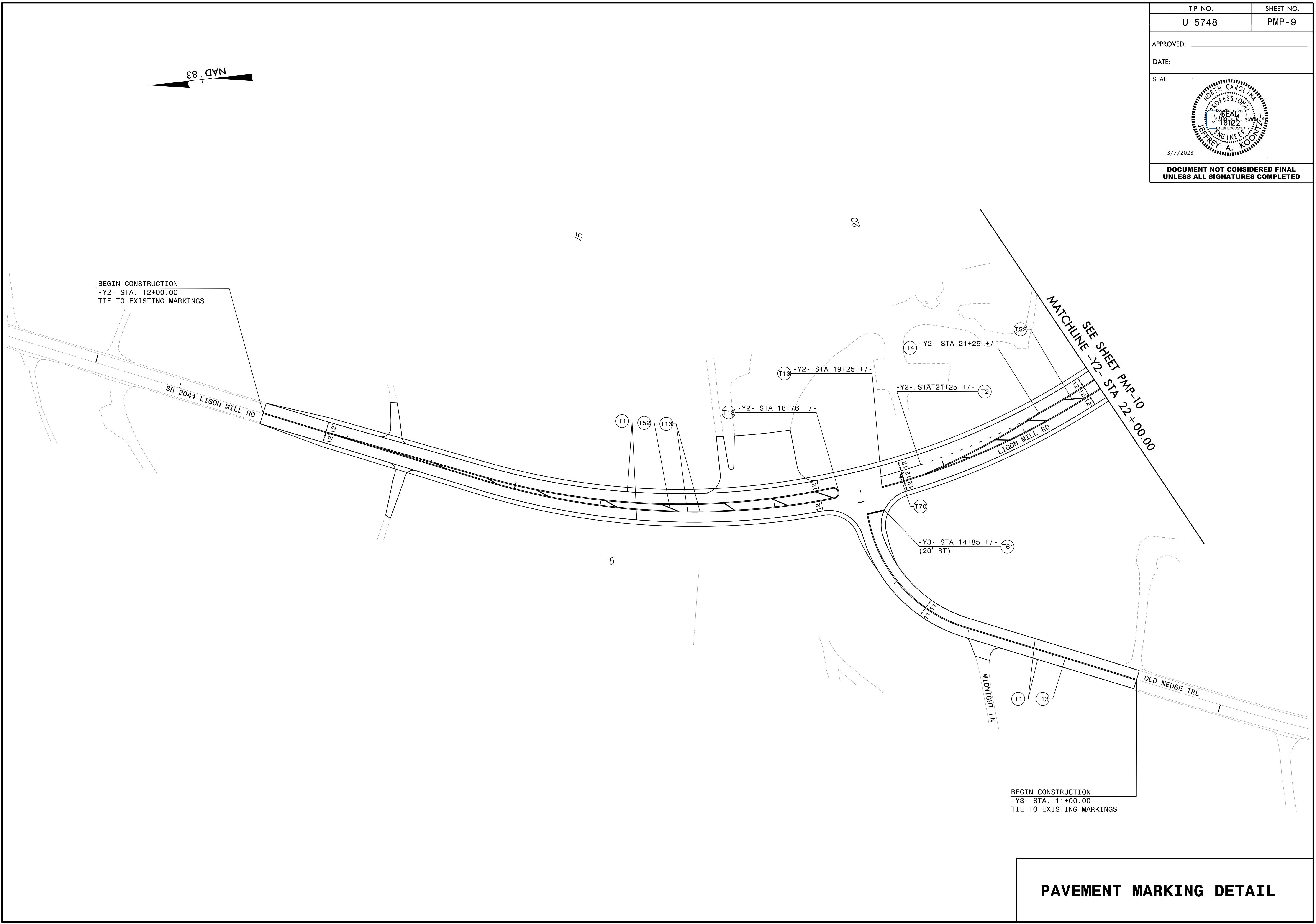

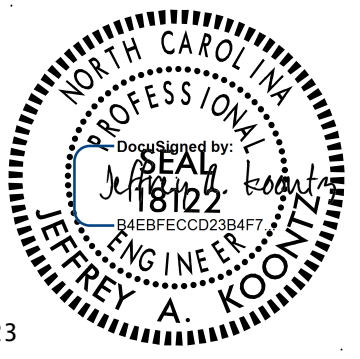
TIP NO.	SHEET NO.
U-5748	PMP-10
APPROVED: _____	
DATE: _____	
SEAL	
	
3/7/2023	
DOCUMENT NOT CONSIDERED FINAL UNLESS ALL SIGNATURES COMPLETED	

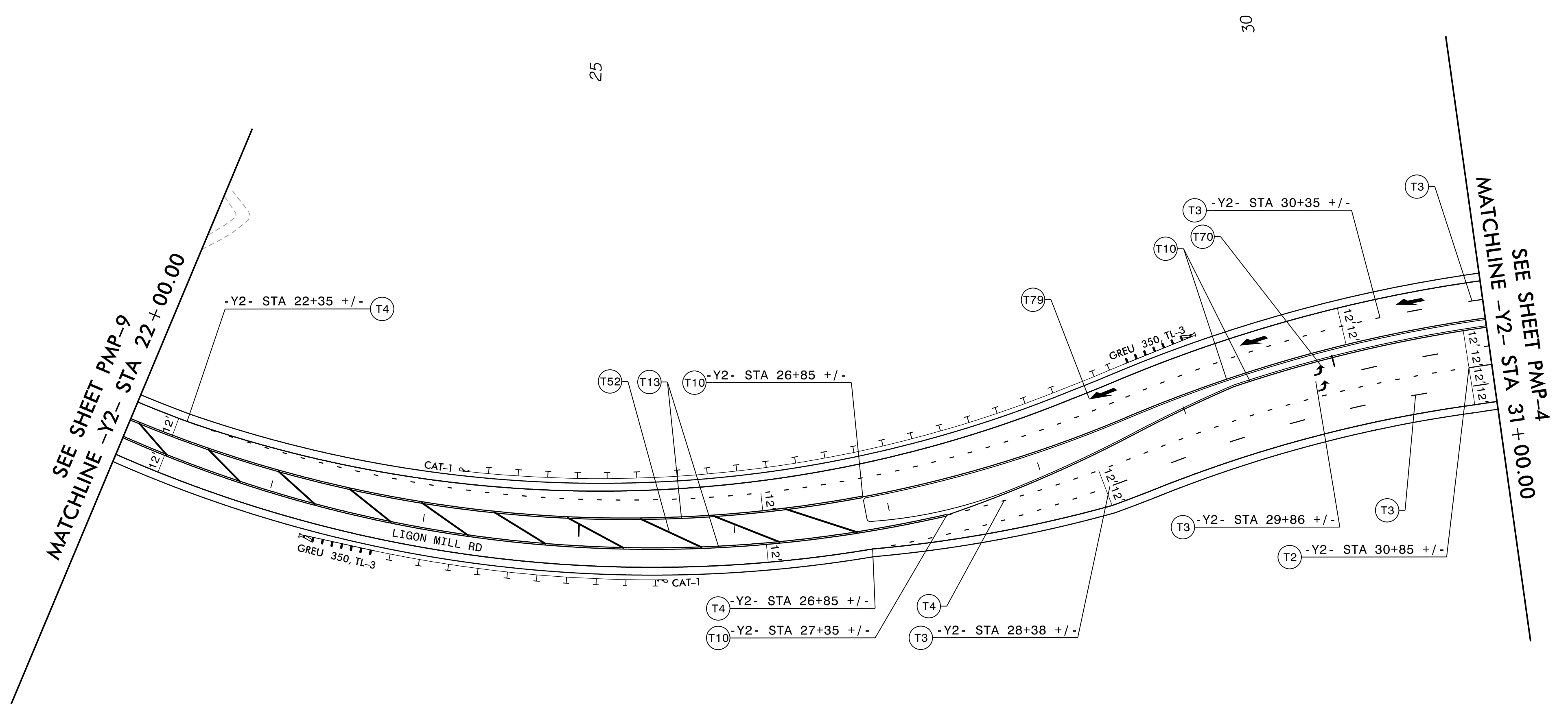
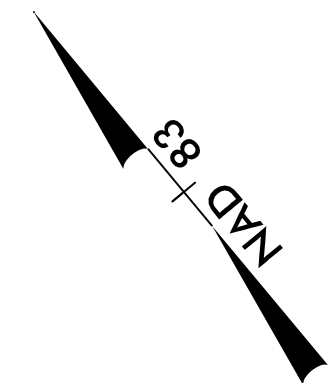

PAVEMENT MARKING DETAIL

1/11/2023
 p:\w\l\cecom-mc-pw-bentley.com\AECOM\DS2\NA_2020\Documents\60609754-U-5748 Ligon Mill\900-CAD GIS\910-CAD\70-NCDDOT_TIP\Traffic\PM\U5748_pmp.psh10.dgn
 POST: lck.mcdpeter@son

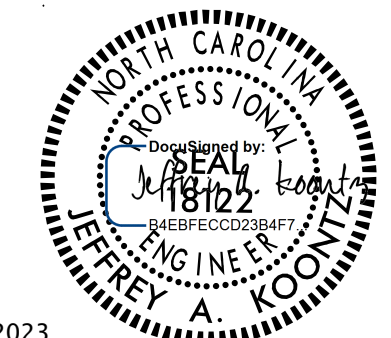
TIP NO.	SHEET NO.
U-5748	PMP-11
APPROVED: _____	
DATE: _____	
SEAL	
	
3/7/2023	
DOCUMENT NOT CONSIDERED FINAL UNLESS ALL SIGNATURES COMPLETED	

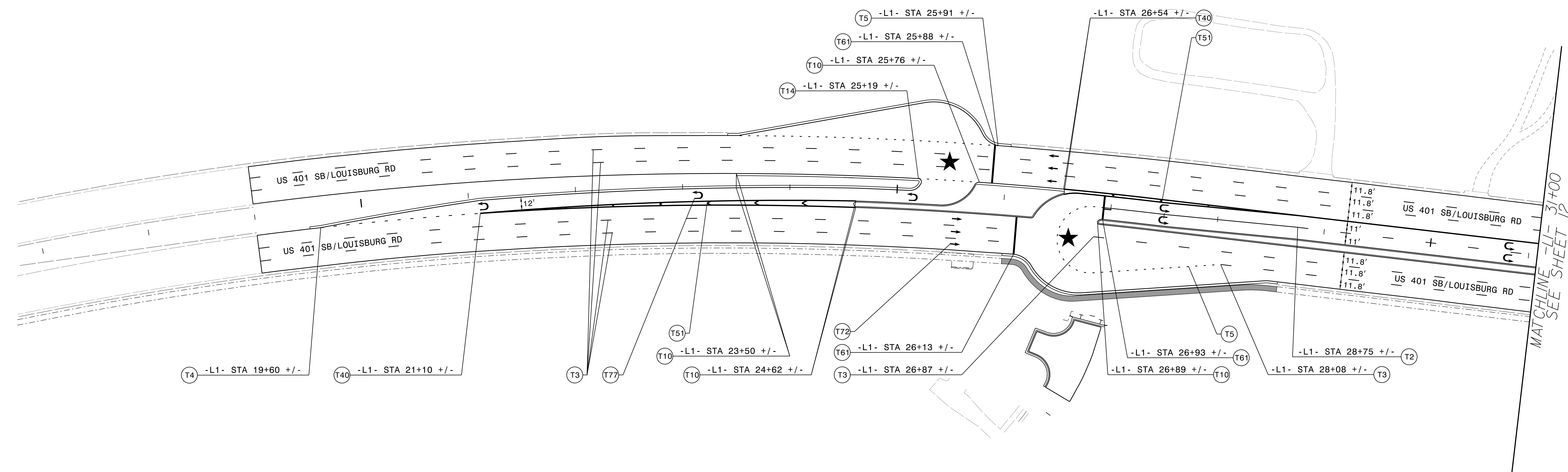
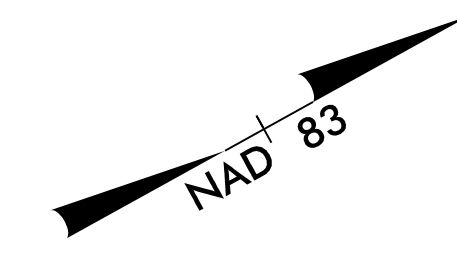

★ PROPOSED SIGNAL

PAVEMENT MARKING DETAIL

I/1/2023
 p:\1\cecom-mc-pw-bentley.com\AECOM_DS2\NA_2020\Documents\60609754-U-5748 Ligon Mill\900-CAD GIS\900-CAD GIS\900-CAD\70-NC DOT_TIP\Traffic\PMMP\U5748_pmp.dsh\l.dgn
 POST: lck.mcdpeter.son

TIP NO.	SHEET NO.
U-5748	PMP-12
APPROVED: _____	
DATE: _____	
SEAL	
3/7/2023	
DOCUMENT NOT CONSIDERED FINAL UNLESS ALL SIGNATURES COMPLETED	

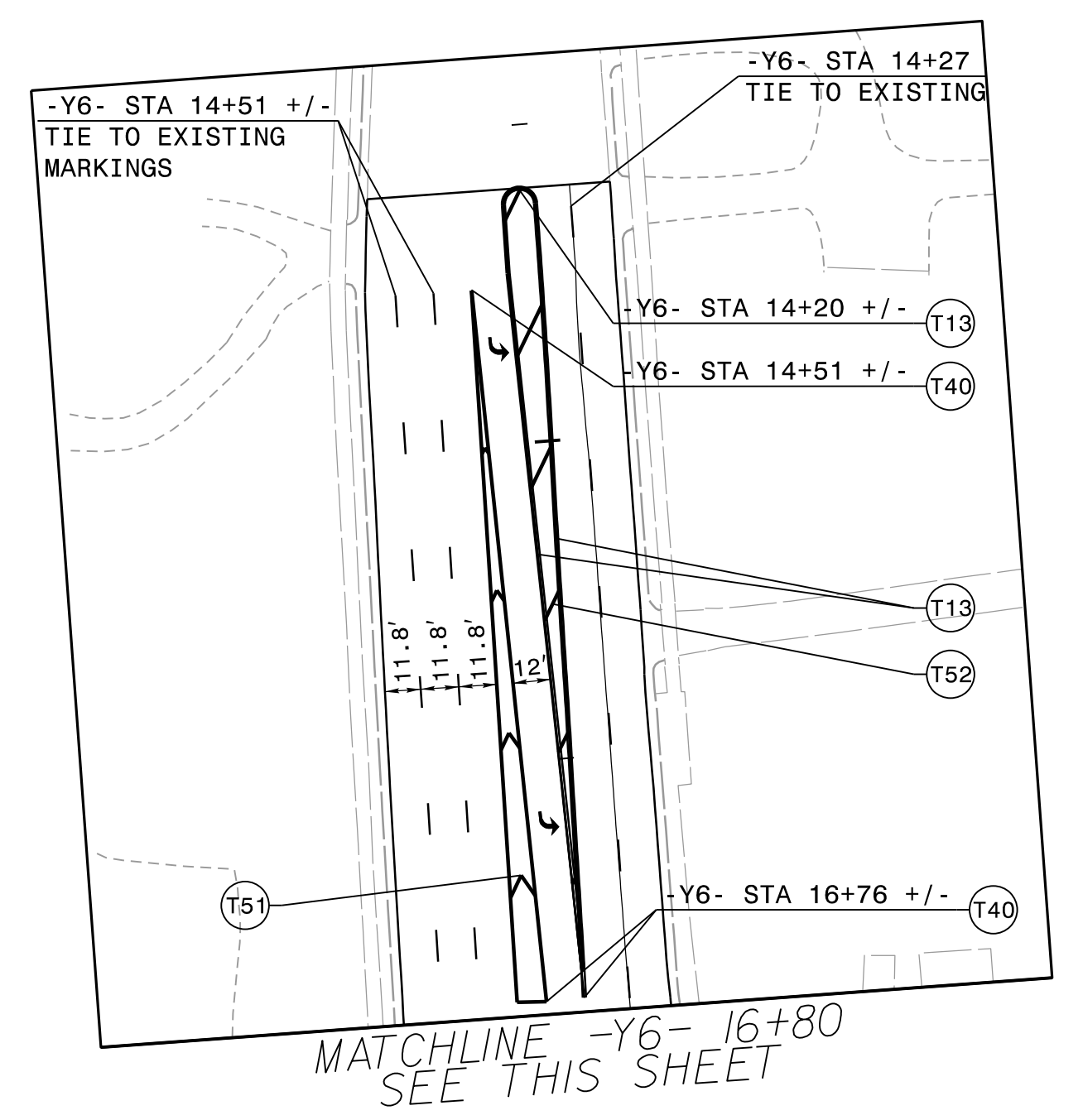

- CURB RAMP LOCATIONS**
- ⑩⑥ -Y6- 20+47 +/- 89' RT (T2)
 - ⑩⑦ Y6- 20+59 +/- 0' RT (M.I. CUT THROUGH)
 - ⑩⑧ Y6- 20+67 +/- 68' LT (T3)
 - ⑩⑨ -L1- 41+17 +/- 0' LT (M.I. CUT THROUGH)
 - ⑩⑩ -Y7- 10+71 +/- 75' RT (T1A)
 - ⑩⑪ -Y7- 10+87 +/- 58' RT (T3)
 - ⑩⑫ -Y7- 10+89 +/- 0' RT (M.I. CUT THROUGH)
 - ⑩⑬ -Y7- 10+91 +/- 49' LT (T3)

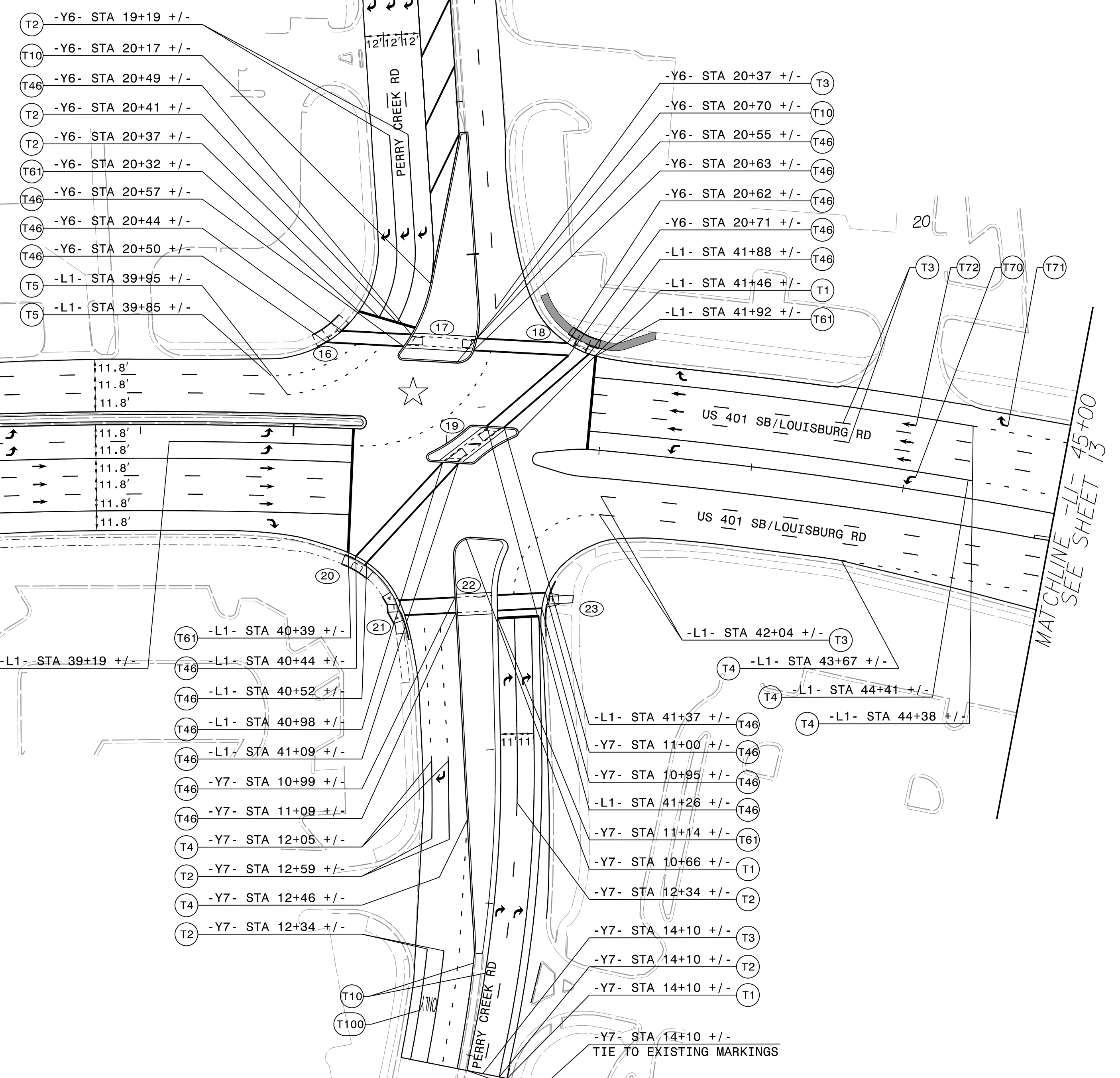

PAVEMENT MARKING DETAIL



1/11/2023
 p:\w\l\gecom-mc-pw-bentley.com\MECOM_DS21\NA_2020\Documents\60609754-U-5748 Ligon MII\900-CAD 05\90-CAD\70-NCDDT_TIP\Traffic\PMMP\U5748_pmp_psh12.dgn
 POST: lck.mcdpeter.son

TIP NO.	SHEET NO.
U-5748	PMP-13
APPROVED: _____	
DATE: _____	
SEAL	
3/7/2023	
DOCUMENT NOT CONSIDERED FINAL UNLESS ALL SIGNATURES COMPLETED	

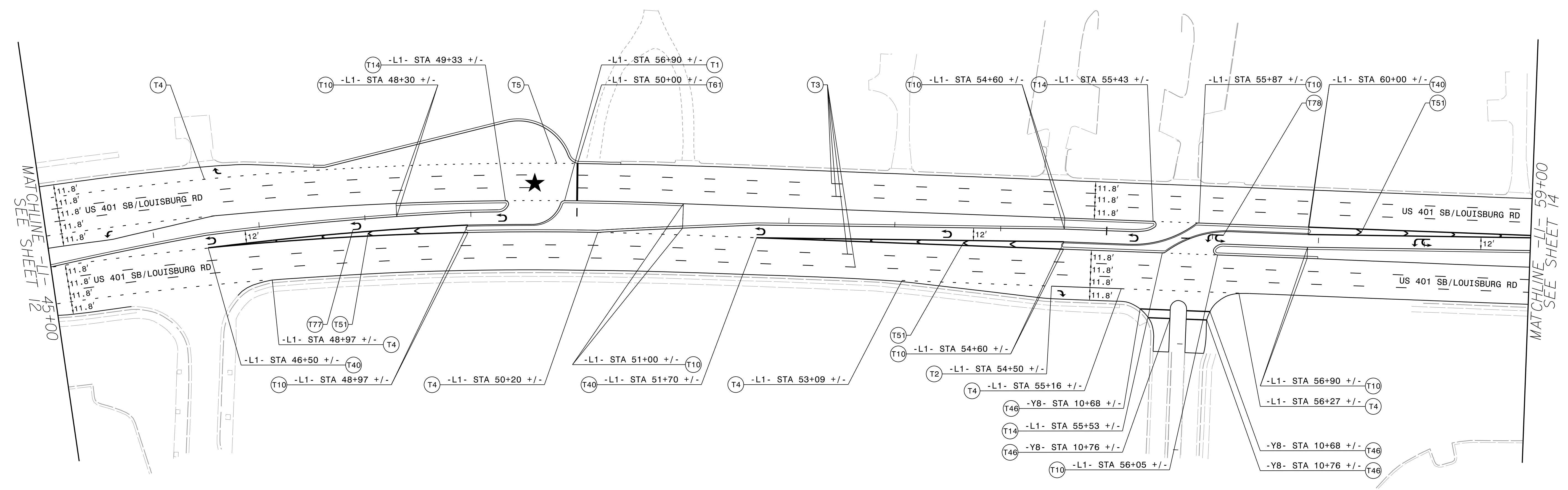
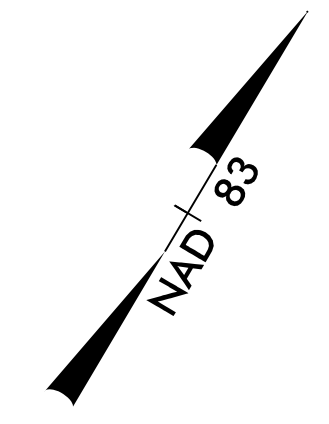

★ PROPOSED SIGNAL

PAVEMENT MARKING DETAIL

1/11/2023
 p:\w\l\cecom-mc-pw-bentley.com\AECOM\DS2\NA_2020\Documents\60609754-U-5748 Ligon MI\900-CAD_GS\900-CAD\70_NCDOT_TIP\Traffic\PM\U5748_pmp.dsh3.dgn
 POST: lck.mcdpeter@son

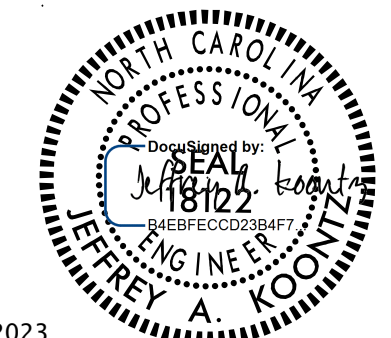
TIP NO.	SHEET NO.
U-5748	PMP-14
APPROVED: _____	
DATE: _____	
SEAL	
	
3/7/2023	
DOCUMENT NOT CONSIDERED FINAL UNLESS ALL SIGNATURES COMPLETED	

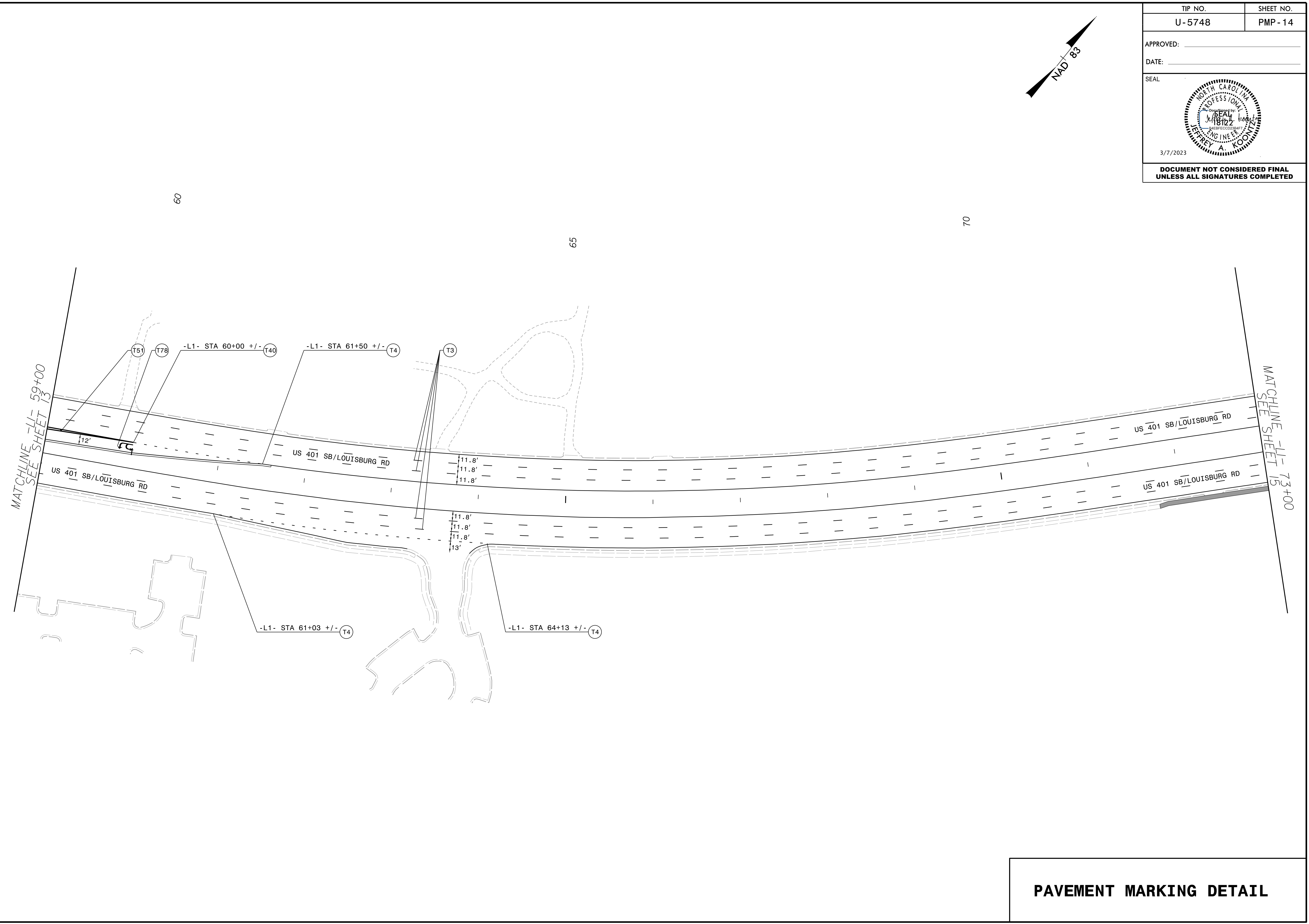
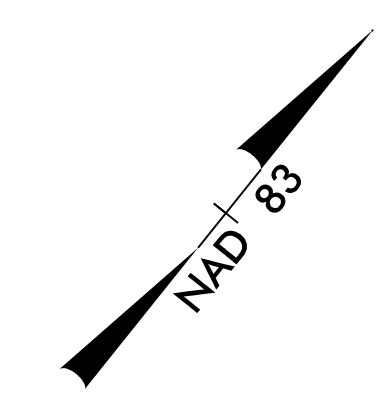

PAVEMENT MARKING DETAIL

1/11/2023
 p:\w\l\cecom-mc-pw-bentley.com\AECOM_DS2\NA_2020\Documents\60609754-U-5748 Ligon MI\900-CAD 05\90-CAD\70-NCDDOT_TIP\Traffic\PM\U5748_pmp.pshl4.dgn
 POST: lck.mcdpeter@son

5/14/99

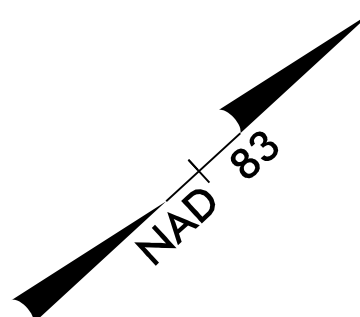

TIP NO.	SHEET NO.
U-5748	PMP-15
APPROVED: _____	
DATE: _____	
SEAL	
3/7/2023	
DOCUMENT NOT CONSIDERED FINAL UNLESS ALL SIGNATURES COMPLETED	

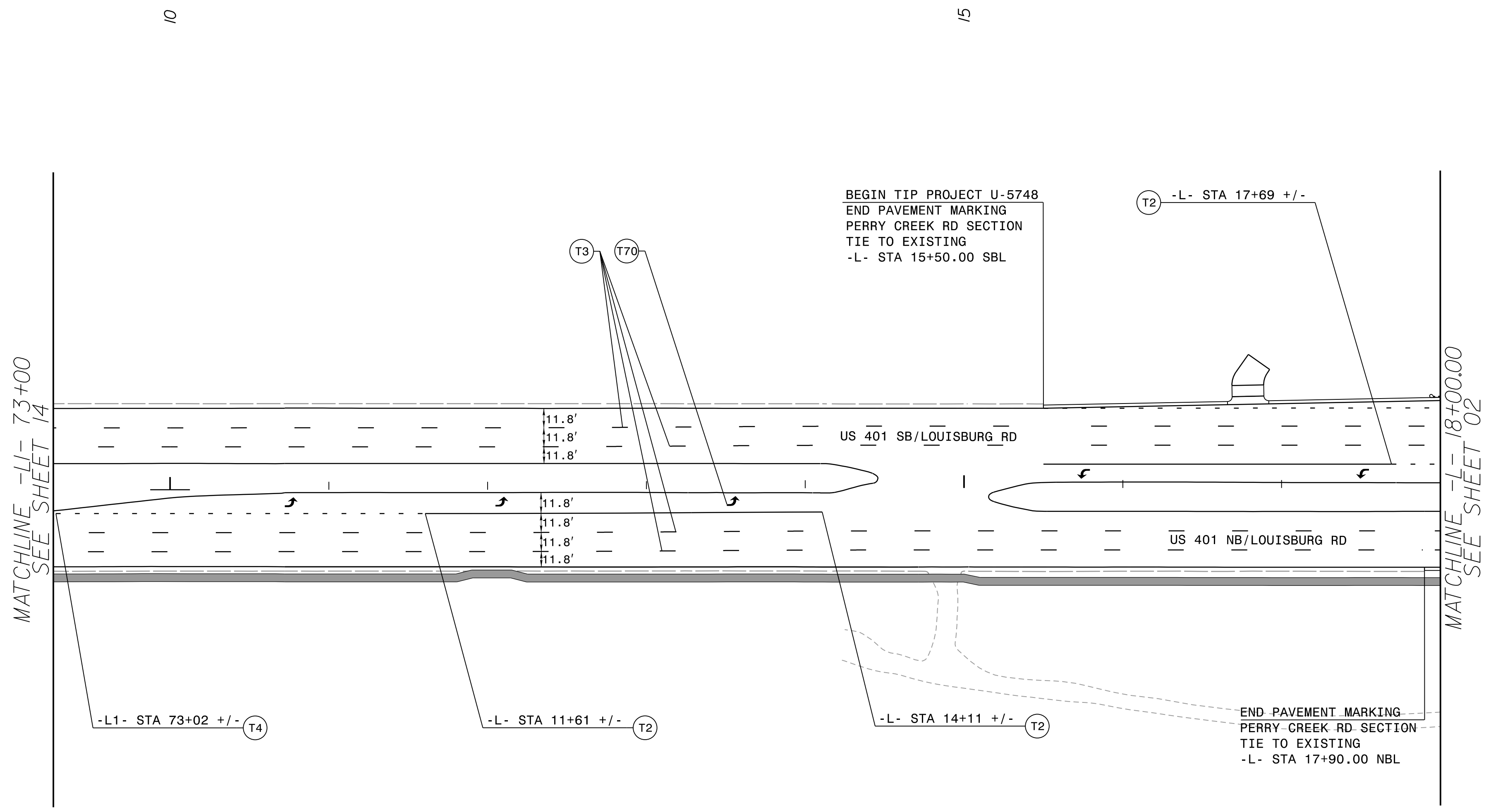

I/1/2023 p:\1\cecom-mc-pw-bentley.com\AECOM\DS2\NA_2020\Documents\60609754-U-5748 Ligon MII\900-CAD GIS\910-CAD\70-NC DOT_TIP\Traffic\PM\U5748_pmp.dsh15.dgn POST tick.mcd\peter.son

PAVEMENT MARKING DETAIL