



T.I.P.: R-2707D

CONTRACT NO.: C204851

**STATE OF NORTH CAROLINA  
DEPARTMENT OF TRANSPORTATION**

**PAVEMENT MARKING PLAN  
CLEVELAND COUNTY**

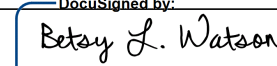
**LOCATION: US 74 FROM EAST OF SR 1162 (PEACHTREE RD) TO WEST OF  
WESTERN END OF US 74 SHELBY BYPASS AND US 74 SHELBY BYPASS FROM EAST  
OF SR 1926 (AIRPORT RD) TO EXISTING US 74 WEST OF SR 2238 (LONG BRANCH RD)**

TIP NO. <b>R-2707D</b>	SHEET NO. <b>PMP - 1</b>
DocuSigned by:  APPROVED: _____ DATE: 4/24/2023	
	
<b>DOCUMENT NOT CONSIDERED FINAL UNLESS ALL SIGNATURES COMPLETED</b>	

**FINAL PAVEMENT MARKING SCHEDULE**

SYMBOL	DESCRIPTION	PAY ITEM	
C1	WHITE EDGELINE	(4")	COLD APPLIED PLASTIC
C13	YELLOW DOUBLE CENTER	(4")	COLD APPLIED PLASTIC
C51	WHITE DIAGONAL	(12")	COLD APPLIED PLASTIC
C52	YELLOW DIAGONAL	(12")	COLD APPLIED PLASTIC
C71	RIGHT TURN ARROW		COLD APPLIED PLASTIC
C74	COMBO RIGHT/STRAIGHT ARROW		COLD APPLIED PLASTIC
C79	MERGE ARROW		COLD APPLIED PLASTIC
C100	ALPHANUMERIC CHAR		COLD APPLIED PLASTIC
T1	WHITE EDGELINE	(4", 90 MILS)	THERMOPLASTIC
T5	2 FT-6FT/SP WHITE MINISKIP	(4", 90 MILS)	THERMOPLASTIC
T13	YELLOW DOUBLE CENTER	(4", 90 MILS)	THERMOPLASTIC
T41	WHITE DIAGONAL	(8", 90 MILS)	THERMOPLASTIC
T61	WHITE STOPBAR	(24", 90 MILS)	THERMOPLASTIC
T71	RIGHT TURN ARROW	(90 MILS)	THERMOPLASTIC
T73	COMBO LEFT/STRAIGHT ARROW	(90 MILS)	THERMOPLASTIC
T80	WRONG-WAY RAMP ARROW	(90 MILS)	THERMOPLASTIC
T103	24" YIELD LINE TRIANGLE	(90 MILS)	THERMOPLASTIC
T112	FISH-HOOK RIGHT/STRAIGHT ARROW	(90 MILS)	THERMOPLASTIC
T117	FISH-HOOK W/ CIRCLE LEFT/STRAIGHT ARROW	(90 MILS)	THERMOPLASTIC
T118	FISH-HOOK W/ CIRCLE LEFT/RIGHT/STRAIGHT ARROW	(90 MILS)	THERMOPLASTIC
V20	WHITE EDGELINE	(6", 20 MILS)	POLYUREA WITH STANDARD GLASS BEADS
V21	WHITE SOLID LANE LINE	(6", 20 MILS)	POLYUREA WITH STANDARD GLASS BEADS
V22	10 FT WHITE SKIP	(6", 20 MILS)	POLYUREA WITH STANDARD GLASS BEADS
V23	3 FT-9FT/SP WHITE MINISKIP	(6", 20 MILS)	POLYUREA WITH STANDARD GLASS BEADS
V24	2 FT-6FT/SP WHITE MINISKIP	(6", 20 MILS)	POLYUREA WITH STANDARD GLASS BEADS
V30	YELLOW EDGELINE	(6", 20 MILS)	POLYUREA WITH STANDARD GLASS BEADS
V34	2 FT-6FT/SP YELLOW MINISKIP	(6", 20 MILS)	POLYUREA WITH STANDARD GLASS BEADS
V40	WHITE GORELINE	(8", 20 MILS)	POLYUREA WITH STANDARD GLASS BEADS
V45	3 FT-3FT/SP WHITE MINISKIP	(8", 20 MILS)	POLYUREA WITH STANDARD GLASS BEADS
V50	WHITE GORELINE	(12", 20 MILS)	POLYUREA WITH STANDARD GLASS BEADS
V53	WHITE SOLID LANE LINE	(12", 20 MILS)	POLYUREA WITH STANDARD GLASS BEADS
V54	3 FT-9FT/SP WHITE MINISKIP	(12", 20 MILS)	POLYUREA WITH STANDARD GLASS BEADS

**GENERAL NOTES**

THE FOLLOWING GENERAL NOTES APPLY AT ALL TIMES FOR THE DURATION OF THE CONSTRUCTION PROJECT, EXCEPT WHEN OTHERWISE NOTED IN THE PLAN, OR DIRECTED BY THE ENGINEER.

A) INSTALL PAVEMENT MARKINGS AND PAVEMENT MARKERS ON THE FINAL SURFACE AS FOLLOWS:

ROAD NAME	MARKING	MARKER
-L-, RAMPS, LOOPS, -Y5-	POLYUREA WITH STANDARD GLASS BEADS	SNOWPLOWABLE
-L- BRIDGES	POLYUREA WITH STANDARD GLASS BEADS	RAISED
-Y- LINES	THERMOPLASTIC	SNOWPLOWABLE
-Y- LINE BRIDGES	COLD APPLIED PLASTIC	RAISED

B) TIE PROPOSED PAVEMENT MARKING LINES TO EXISTING PAVEMENT MARKING LINES.  
 C) REMOVE/REPLACE ANY CONFLICTING/DAMAGED PAVEMENT MARKINGS AND MARKERS.  
 D) PASSING ZONES WILL BE DETERMINED IN THE FIELD AND MUST BE APPROVED BY THE ENGINEER.  
 E) STOP BAR LOCATION AT NON-SIGNALIZED INTERSECTIONS MAY BE ADJUSTED AS DIRECTED BY THE ENGINEER.  
 F) REMOVE ALL RESIDUE AND SURFACE LAITANCE BY ACCEPTABLE METHODS ON CONCRETE BRIDGE DECKS PRIOR TO PLACING POLYUREA OR COLD APPLIED PLASTIC PAVEMENT MARKING MATERIAL.  
 G) UNLESS OTHERWISE SPECIFIED, HEATED-IN-PLACE THERMOPLASTIC MAY BE USED IN LIEU OF EXTRUDED THERMOPLASTIC FOR STOP BARS, SYMBOLS, CHARACTERS AND DIAGONALS. IF HEATED-IN-PLACE IS USED, IT SHALL BE PAID FOR USING THE EXTRUDED THERMOPLASTIC PAY ITEM.  
 H) UNLESS OTHERWISE SPECIFIED, HEATED-IN-PLACE THERMOPLASTIC MAY BE USED IN LIEU OF COLD APPLIED PLASTIC FOR STOP BARS, SYMBOLS, CHARACTERS AND DIAGONALS ON ASPHALT OR CONCRETE ROADWAYS. IF HEATED-IN-PLACE IS USED, IT SHALL BE PAID FOR USING THE COLD APPLIED PAY ITEM.  
 I) TYPE III COLD APPLIED PLASTIC MAY BE USED IN LIEU OF TYPE II COLD APPLIED PLASTIC. IF TYPE III COLD APPLIED PLASTIC IS USED, IT SHALL BE PAID FOR USING THE TYPE II COLD APPLIED PLASTIC PAY ITEM.

**ROADWAY STANDARD DRAWINGS**

THE FOLLOWING ROADWAY STANDARDS AS APPEAR IN "ROADWAY STANDARD DRAWINGS" - PROJECT SERVICES UNIT - N.C. DEPARTMENT OF TRANSPORTATION - RALEIGH, N.C., DATED JANUARY 2018 ARE APPLICABLE TO THIS PROJECT AND BY REFERENCE HEREBY ARE CONSIDERED A PART OF THESE PLANS:

STD. NO.	TITLE
1205.01	PAVEMENT MARKINGS - LINE TYPES & OFFSETS
1205.02	PAVEMENT MARKINGS - 2 LANE & MULTILANE ROADWAYS
1205.03	PAVEMENT MARKINGS - EXIT & ENTRANCE RAMPS
1205.04	PAVEMENT MARKINGS - INTERSECTIONS (SEE SHEET 1A FOR SHEET 2 OF 2)
1205.05	PAVEMENT MARKINGS - TURN LANES
1205.06	PAVEMENT MARKINGS - LANE DROPS
1205.08	PAVEMENT MARKINGS - SYMBOLS & WORD MESSAGES
1205.09	PAVEMENT MARKINGS - PAINTED ISLANDS
1205.12	PAVEMENT MARKINGS - BRIDGES (SEE SHEET 1B)
1205.13	PAVEMENT MARKINGS - LANE REDUCTIONS
1205.14	PAVEMENT MARKINGS - ROUNDABOUTS
1250.01	RAISED PAVEMENT MARKERS - INSTALLATION SPACING
1251.01	RAISED PAVEMENT MARKERS - PERMANENT & TEMPORARY
1253.01	RAISED PAVEMENT MARKERS - SNOWPLOWABLE
1261.01	GUARDRAIL & BARRIER DELINEATORS - INSTALLATION SPACING
1261.02	GUARDRAIL & BARRIER DELINEATORS - TYPES & MOUNTING
1262.01	GUARDRAIL END DELINEATION

<b>PLAN PREPARED BY:</b>	
<b>BETSY L. WATSON, P.E.</b> SENIOR TRANSPORTATION ENGINEER	Stantec Consulting Services Inc. 801 Jones Franklin Road Suite 300 Raleigh, NC 27606 Tel. (919) 851-6866 Fax. (919) 851-7024 www.stantec.com License No. F-0672
<b>ROSI R. HENNEIN</b> TRANSPORTATION DESIGNER	

**INDEX**

SHEET NO.	DESCRIPTION
PMP - 1	PAVEMENT MARKING PLAN TITLE AND SCHEDULE SHEET
PMP - 2-37	PAVEMENT MARKING DETAIL





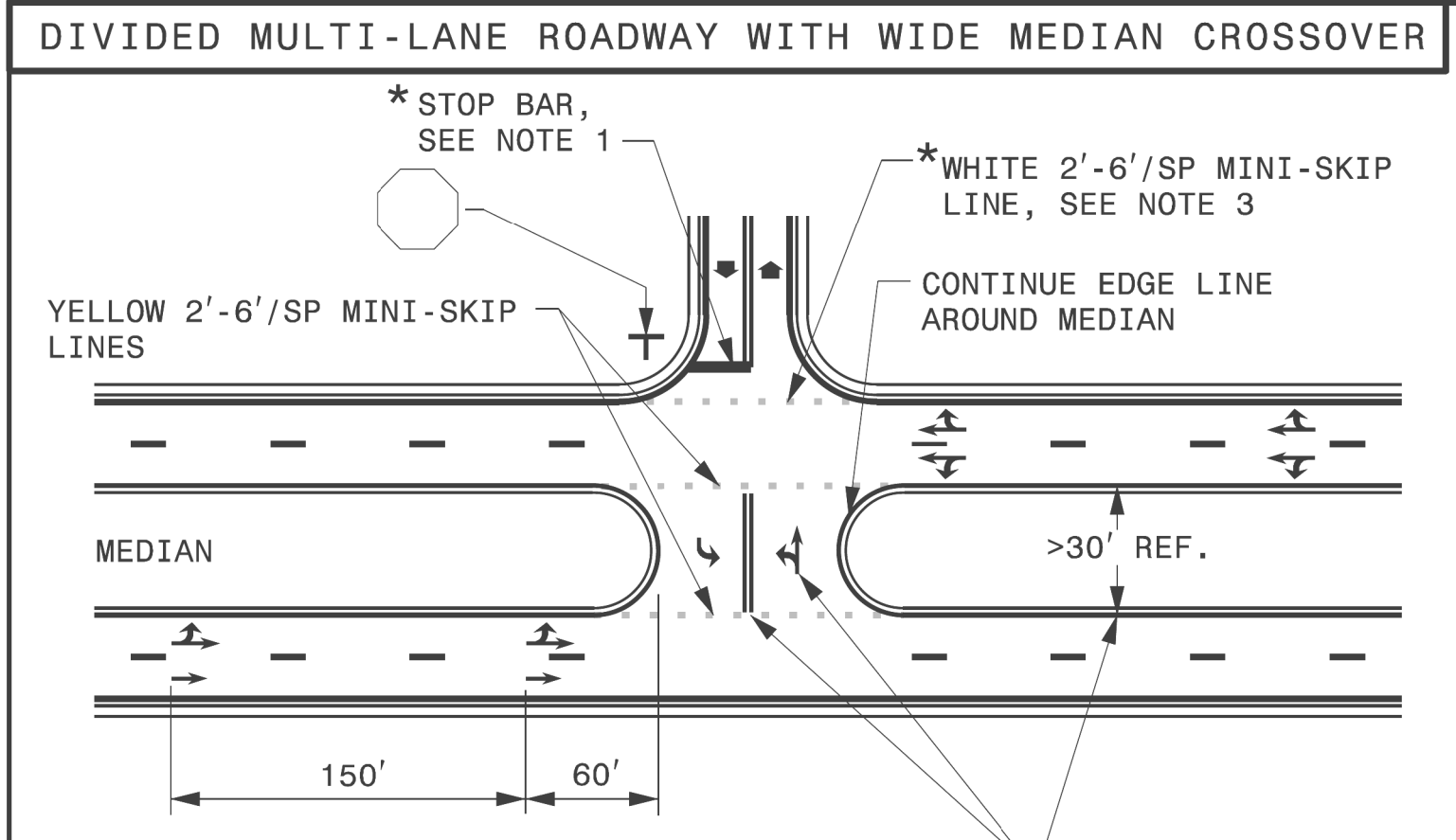
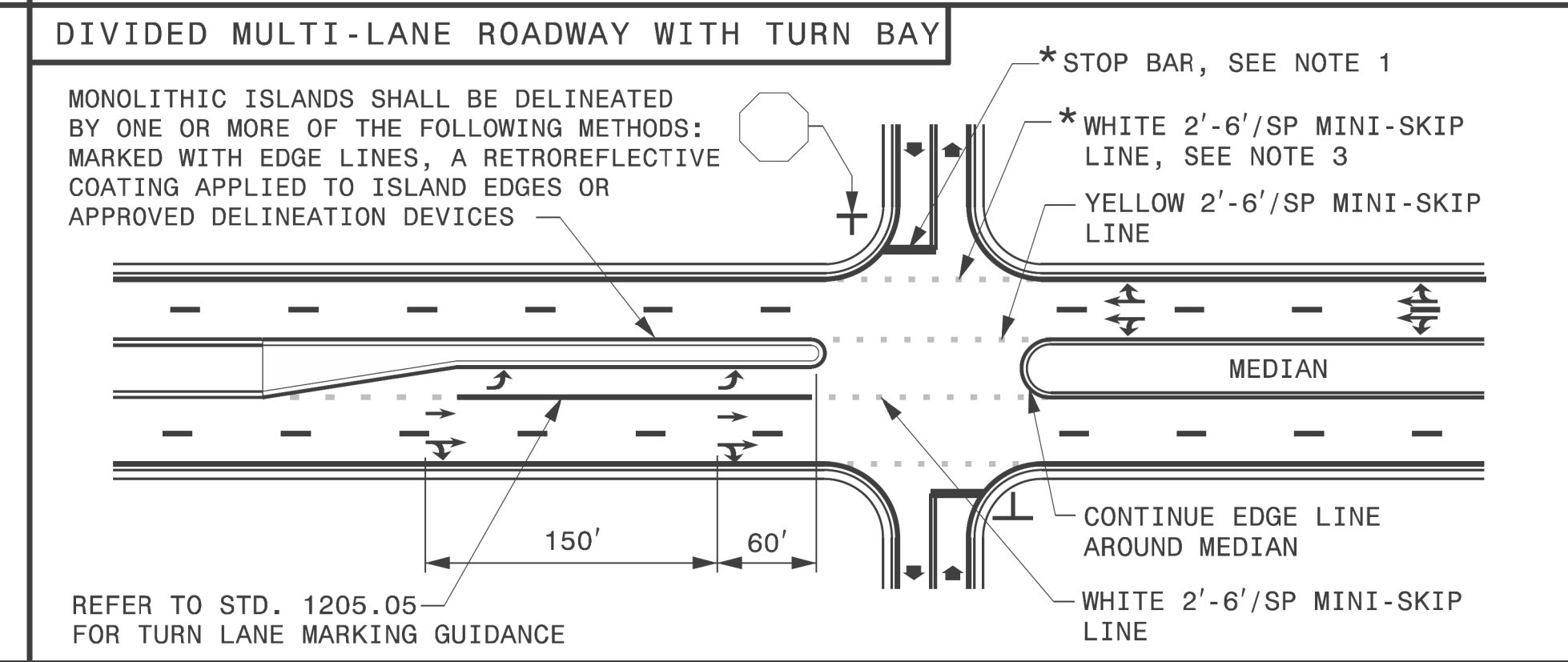
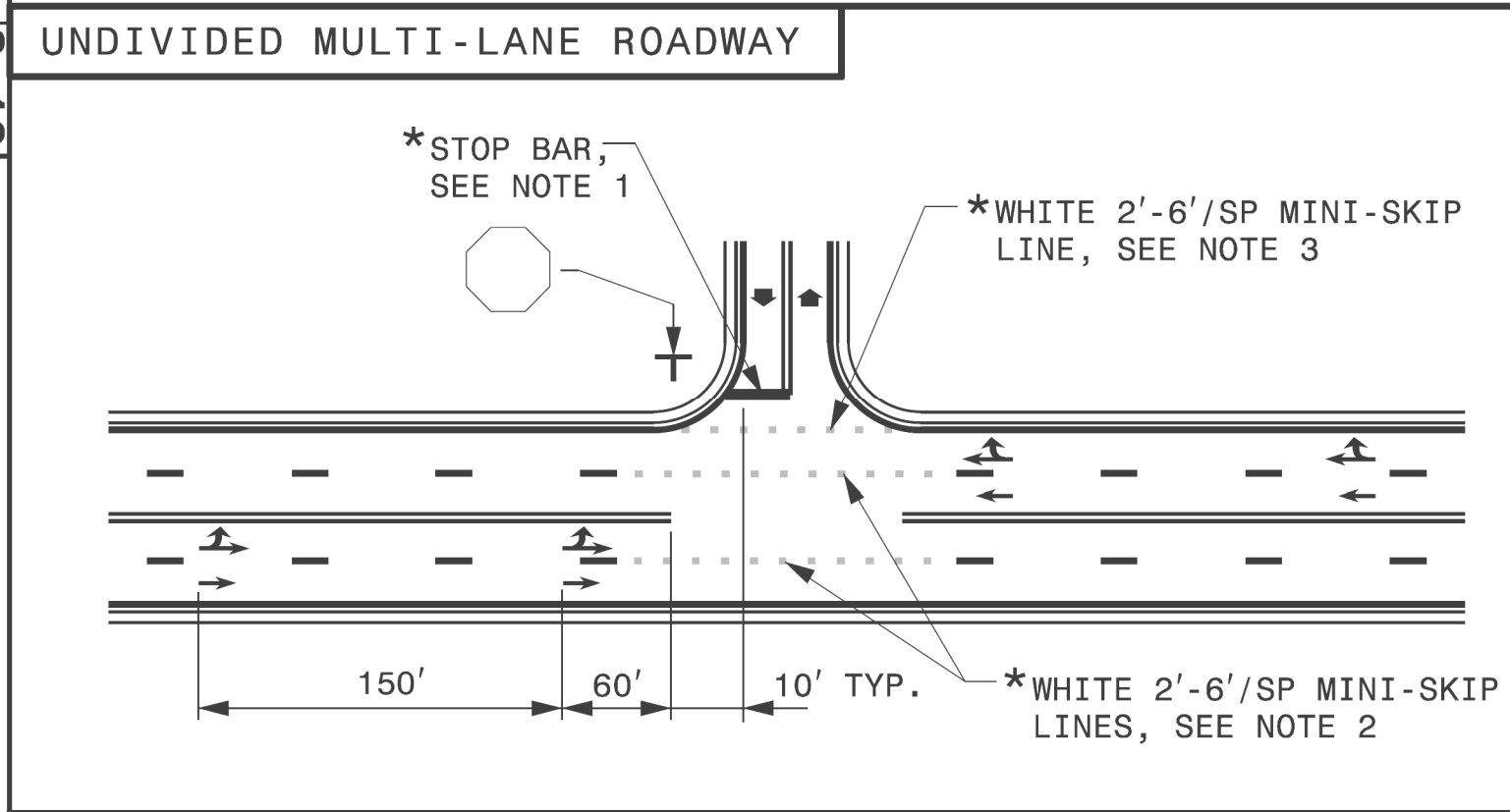
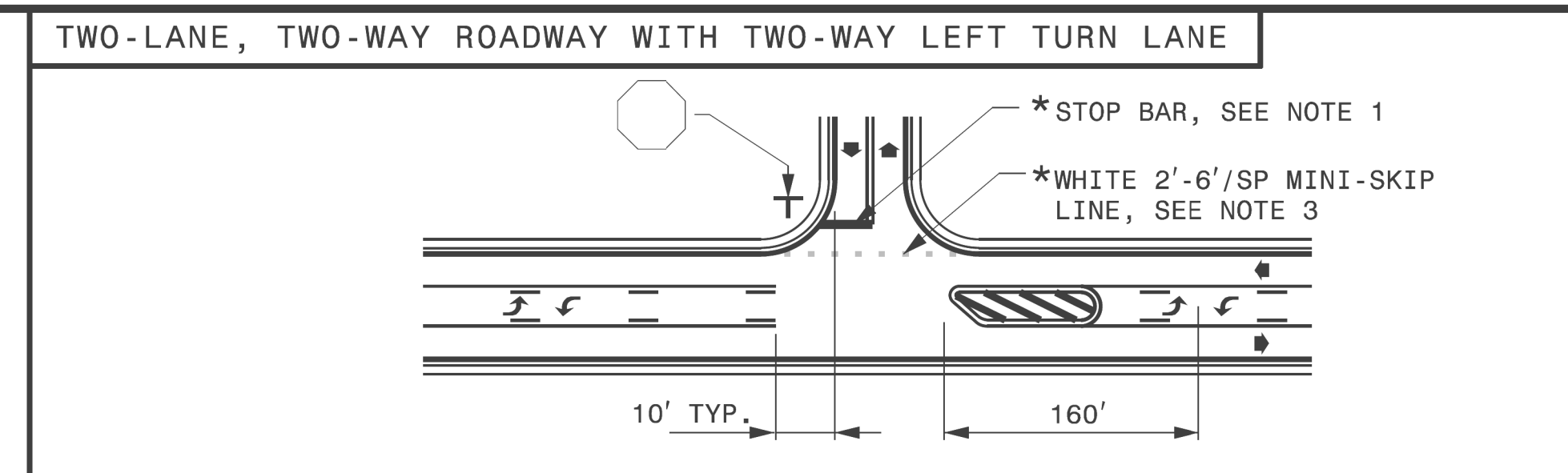
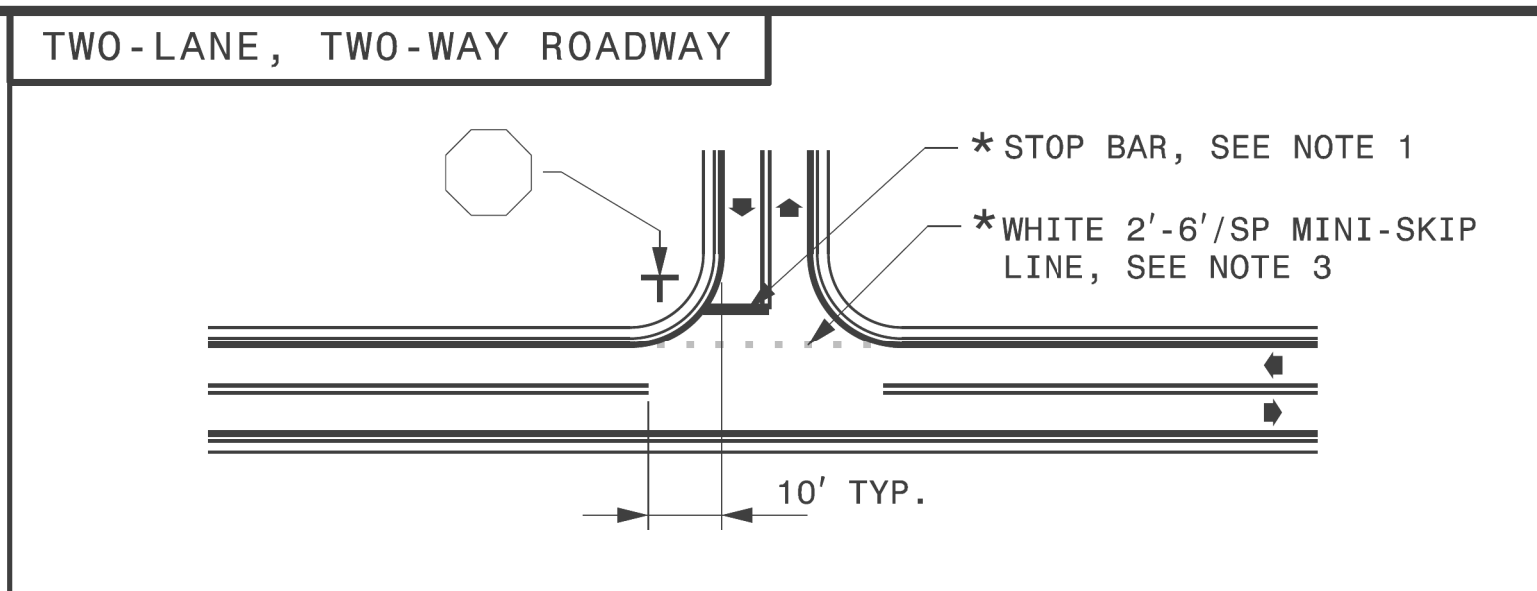

TIP NO.	SHEET NO.
DocuSigned by: <i>Matthew V. Springer</i>	
APPROVED:	8/13/2019
DATE:	8/13/2019 8:58:44 AM
SEAL	
	

STATE OF NORTH CAROLINA  
DEPT. OF TRANSPORTATION  
DIVISION OF HIGHWAYS  
RALEIGH, N.C.

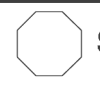

- GENERAL NOTES:**
- 1- PLACEMENT OF STOP BARS AT NON-SIGNALIZED INTERSECTIONS IS OPTIONAL AND USED WHERE IT IS IMPORTANT TO INDICATE THE POINT WHICH VEHICLES ARE REQUIRED TO STOP. PLACE STOP BARS NO LESS THAN 4 FEET AND NO MORE THAN 30 FEET FROM THE NEAREST EDGE OF THE INTERSECTING ROADWAY. USE 10 FEET AS THE TYPICAL SETBACK DISTANCE OR AS DIRECTED BY THE ENGINEER.
  - 2- MINI-SKIP LANE LINE EXTENSIONS SHOULD BE USED AT INTERSECTIONS THAT HAVE REDUCED VISIBILITY CONDITIONS SUCH AS OFFSET, SKEWED, OR CURVED ROADWAYS.
  - 3- MINI-SKIP EDGE LINE EXTENSIONS MAY BE PLACED THROUGH INTERSECTIONS AND MAJOR DRIVEWAYS.
  - 4- REFER TO ROADWAY STANDARD DRAWINGS 1205.01, 1205.02, 1205.05, 1205.08 AND 1205.09 FOR ADDITIONAL PAVEMENT MARKING GUIDANCE.

**LEGEND**

 STOP SIGN	 STATIONARY SIGN
 DIRECTION OF TRAFFIC FLOW	 PAVEMENT MARKING SYMBOLS
* OPTIONAL	

STATE OF NORTH CAROLINA  
DEPT. OF TRANSPORTATION  
DIVISION OF HIGHWAYS  
RALEIGH, N.C.

ENGLISH DETAIL DRAWING FOR  
**PAVEMENT MARKINGS**  
INTERSECTIONS

SHEET 2 OF 2  
**1205D04**

SHEET 2 OF 2  
**1205D04**

**REVISED PAVEMENT MARKING  
ROADWAY STANDARD DRAWING**

REVISED ROADWAY STANDARD DRAWING  
1205.04 SHEET 2 OF 2

\$\$\$\$\$SYTIME\$\$\$\$\$  
\$\$\$\$\$DGN\$\$\$\$\$  
\$\$\$\$\$USERNAME\$\$\$\$\$

C:\Users\stdm\Documents and Settings\stdm\Drawings\2018 Standard Dwg\Division 12 Final\12050402\_08-13-19.dgn  
User:stdm

TIP NO.	SHEET NO.
DocuSigned by:	
<i>Matthew V. Springs</i>	
APPROVED:	8/30/2019
DATE:	8/30/2019
SEAL	

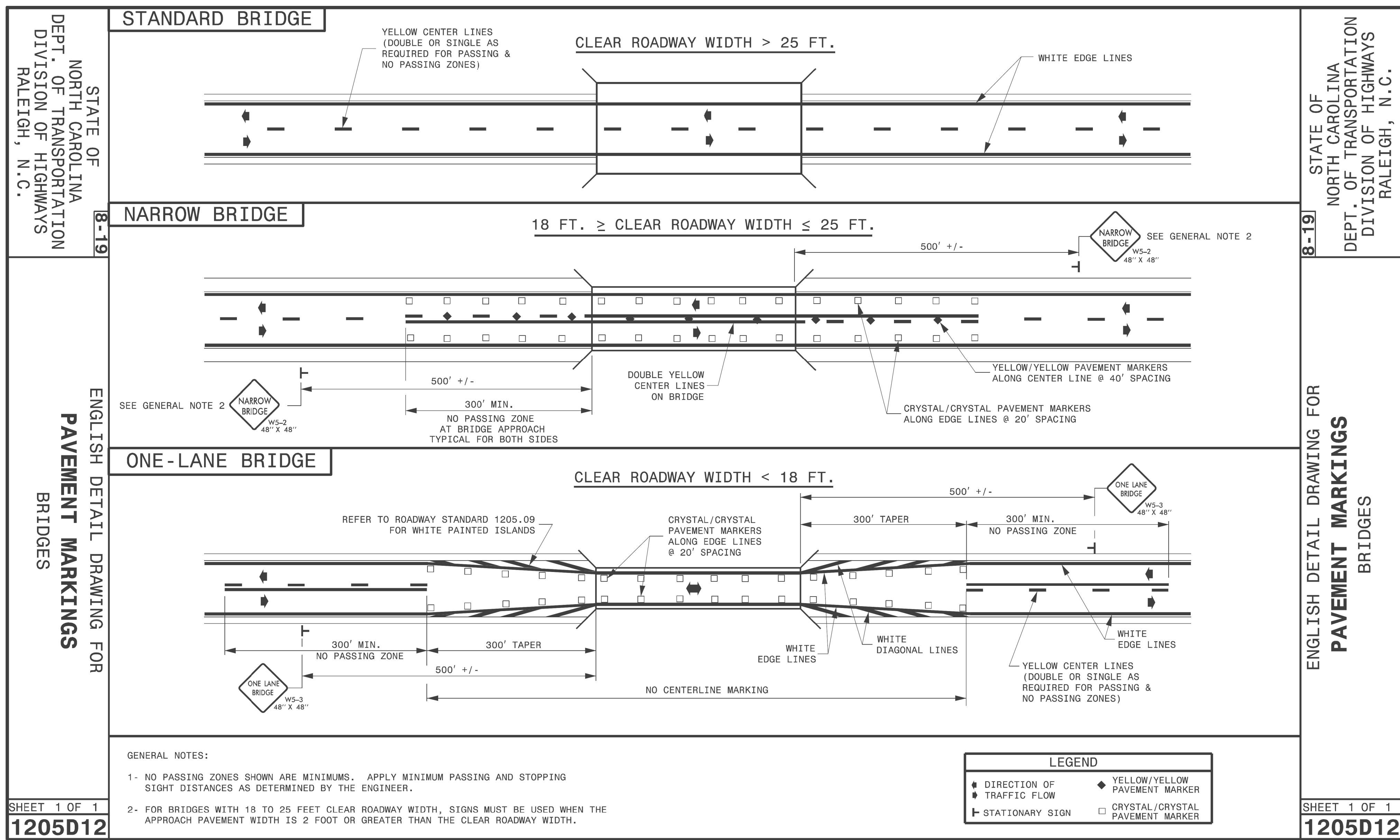

TIP NO. R-2707D	SHEET NO. PMP-2
APPROVED: <i>Betsy L. Watson</i>	
DATE: 4/24/2023	
SEAL	
<p><b>DOCUMENT NOT CONSIDERED FINAL UNLESS ALL SIGNATURES COMPLETED</b></p>	



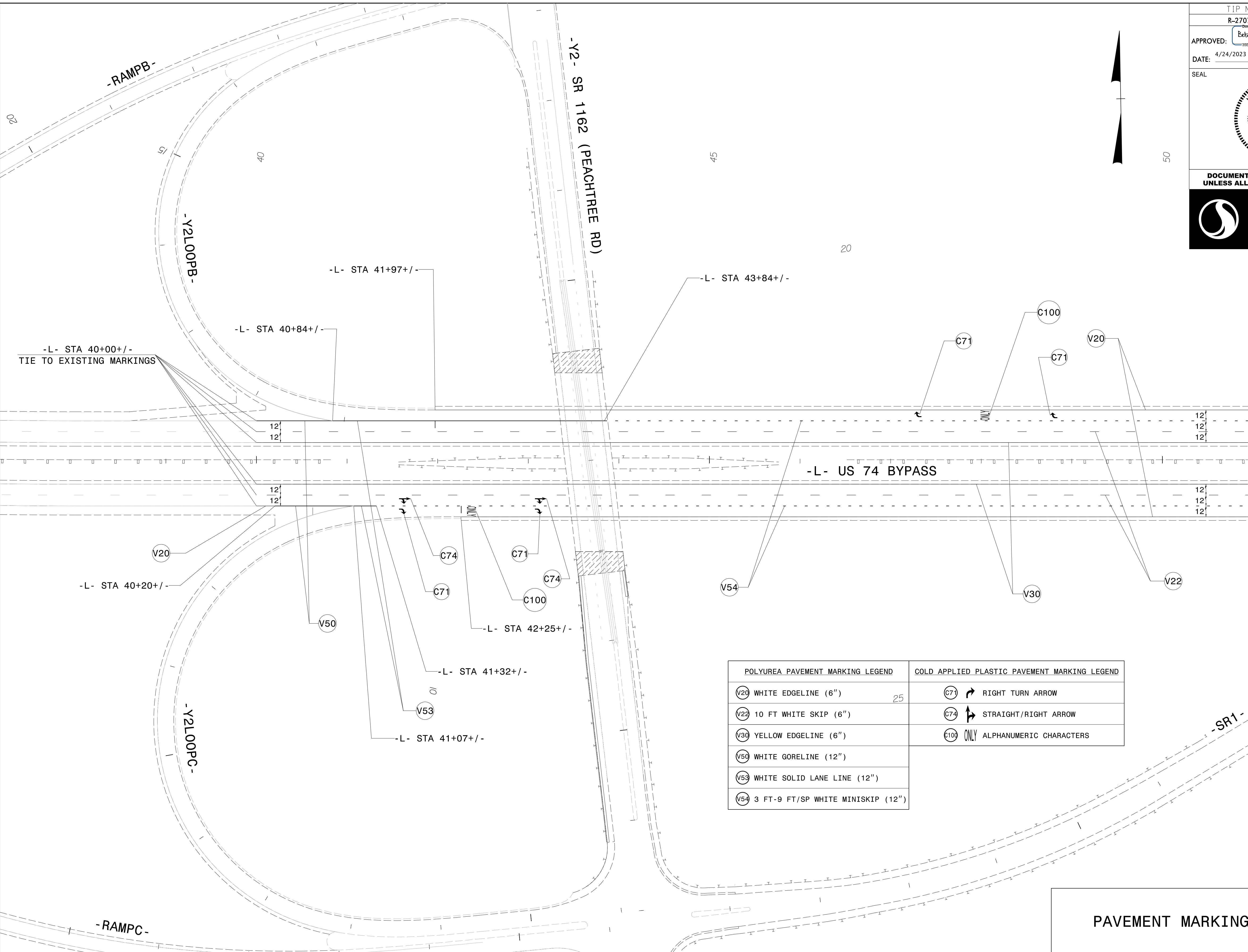
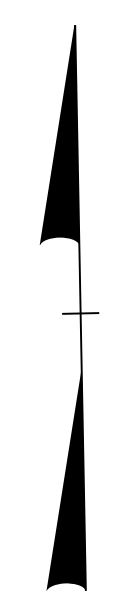

POLYUREA PAVEMENT MARKING LEGEND	COLD APPLIED PLASTIC PAVEMENT MARKING LEGEND
<b>V20</b> WHITE EDGELINE (6")	<b>C71</b> RIGHT TURN ARROW
<b>V22</b> 10 FT WHITE SKIP (6")	<b>C74</b> STRAIGHT/RIGHT ARROW
<b>V30</b> YELLOW EDGELINE (6")	<b>C100</b> ONLY ALPHANUMERIC CHARACTERS
<b>V50</b> WHITE GORELINE (12")	
<b>V53</b> WHITE SOLID LANE LINE (12")	
<b>V54</b> 3 FT-9 FT/SP WHITE MINISKIP (12")	

\$\$\$\$\$SYTIME\$\$\$\$\$  
 \$\$\$\$DDGN\$\$\$\$\$  
 \$\$\$USERNAME\$\$\$\$\$

**PAVEMENT MARKING DETAIL**

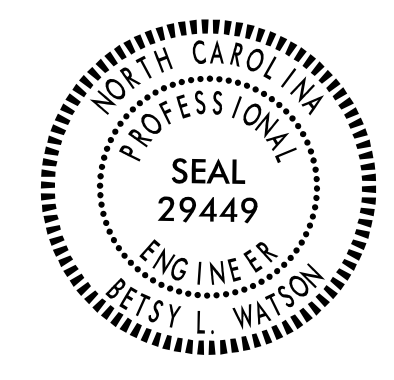
MATCHLINE -L- STA 51+00 SEE SHEET PMP-3

TIP NO. R-2707D	SHEET NO. PMP-3
APPROVED: <i>Betsy L. Watson</i>	
DATE: 4/24/2023	
SEAL	
	
<p><b>DOCUMENT NOT CONSIDERED FINAL UNLESS ALL SIGNATURES COMPLETED</b></p> 	

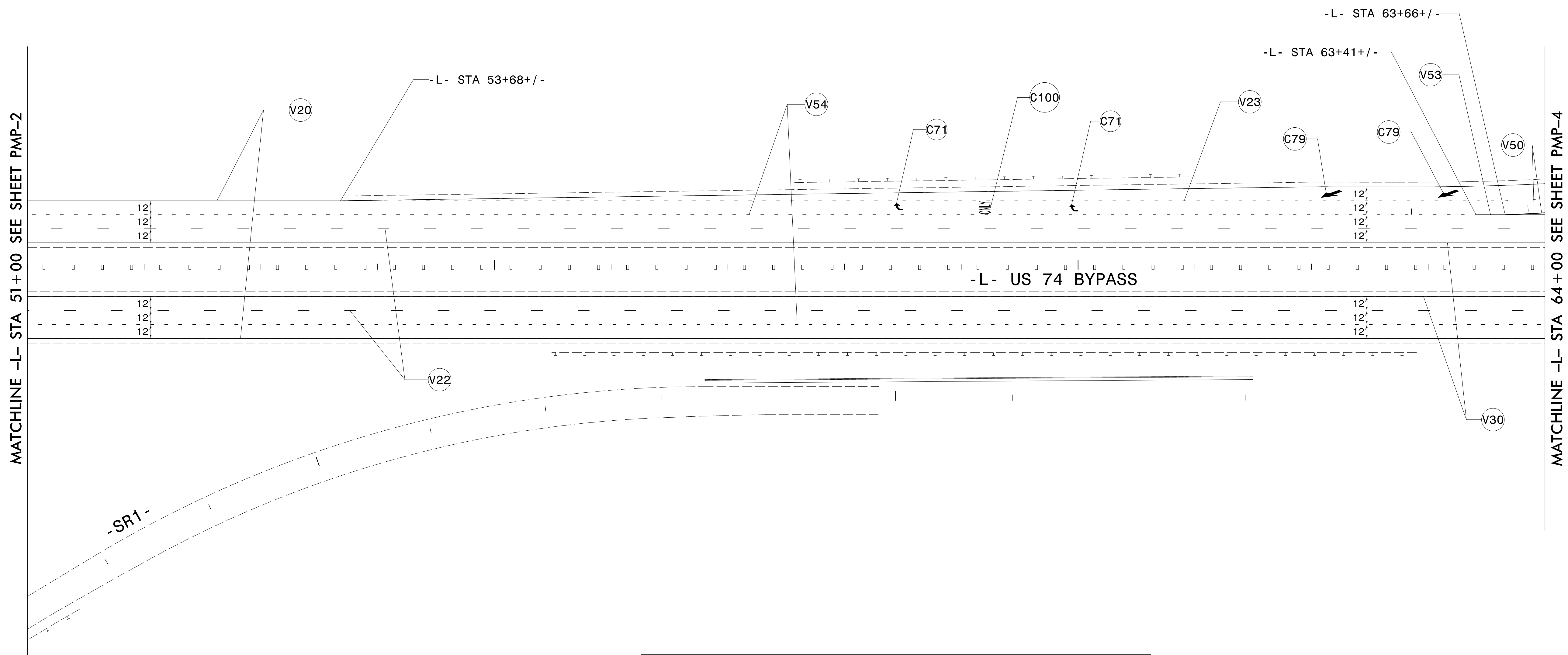
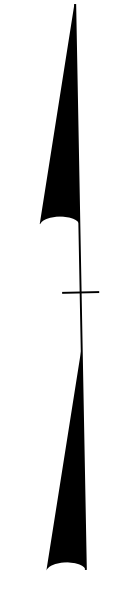



MATCHLINE -L- STA 51+00 SEE SHEET PMP-2

MATCHLINE -L- STA 64+00 SEE SHEET PMP-4



55

60

POLYUREA PAVEMENT MARKING LEGEND	COLD APPLIED PLASTIC PAVEMENT MARKING LEGEND
(V20) WHITE EDGELINE (6")	(C71)  RIGHT TURN ARROW
(V22) 10 FT WHITE SKIP (6")	(C79)  MERGE ARROW
(V23) 3 FT-9 FT/SP WHITE MINISKIP (6")	(C100) ONLY ALPHANUMERIC CHARACTERS
(V30) YELLOW EDGELINE (6")	
(V50) WHITE GORELINE (12")	
(V53) WHITE SOLID LANE LINE (12")	
(V54) 3 FT-9 FT/SP WHITE MINISKIP (12")	

PAVEMENT MARKING DETAIL

\$\$\$\$\$SYTIME\$\$\$\$\$  
\$\$\$\$\$DGN\$\$\$\$\$  
\$\$\$\$\$USERNAME\$\$\$\$\$

TIP NO. R-2707D	SHEET NO. PMP-4
APPROVED: <i>Betsy L. Watson</i> <small>35E67B3AF8743F</small>	
DATE: 4/26/2023	
SEAL	
	
<b>DOCUMENT NOT CONSIDERED FINAL UNLESS ALL SIGNATURES COMPLETED</b>	
	

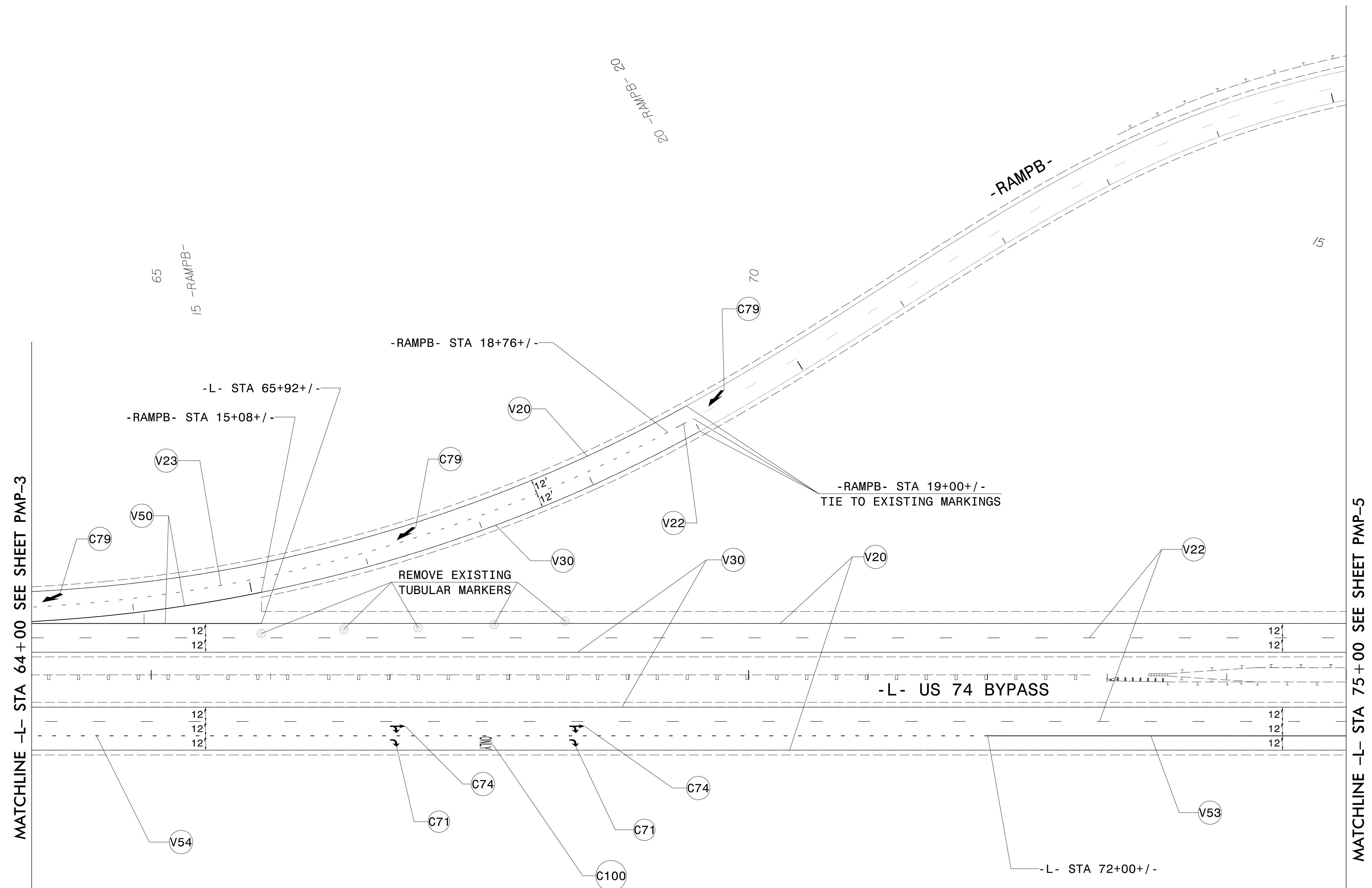

MATCHLINE -L- STA 64+00 SEE SHEET PMP-3

MATCHLINE -L- STA 75+00 SEE SHEET PMP-5

**PROJECT NOTE**



REMOVAL OF TUBULAR MARKERS WILL BE INCIDENTAL TO THE LINE ITEM MILLING ASPHALT PAVEMENT, 1.5 INCH DEPTH

POLYUREA PAVEMENT MARKING LEGEND	COLD APPLIED PLASTIC PAVEMENT MARKING LEGEND
V20 WHITE EDGELINE (6")	C71 RIGHT TURN ARROW
V22 10 FT WHITE SKIP (6")	C74 STRAIGHT/RIGHT ARROW
V23 3 FT-9 FT/SP WHITE MINISKIP (6")	C79 MERGE ARROW
V30 YELLOW EDGELINE (6")	C100 ONLY ALPHANUMERIC CHARACTERS
V50 WHITE GORELINE (12")	
V53 WHITE SOLID LANE LINE (12")	
V54 3 FT-9 FT/SP WHITE MINISKIP (12")	





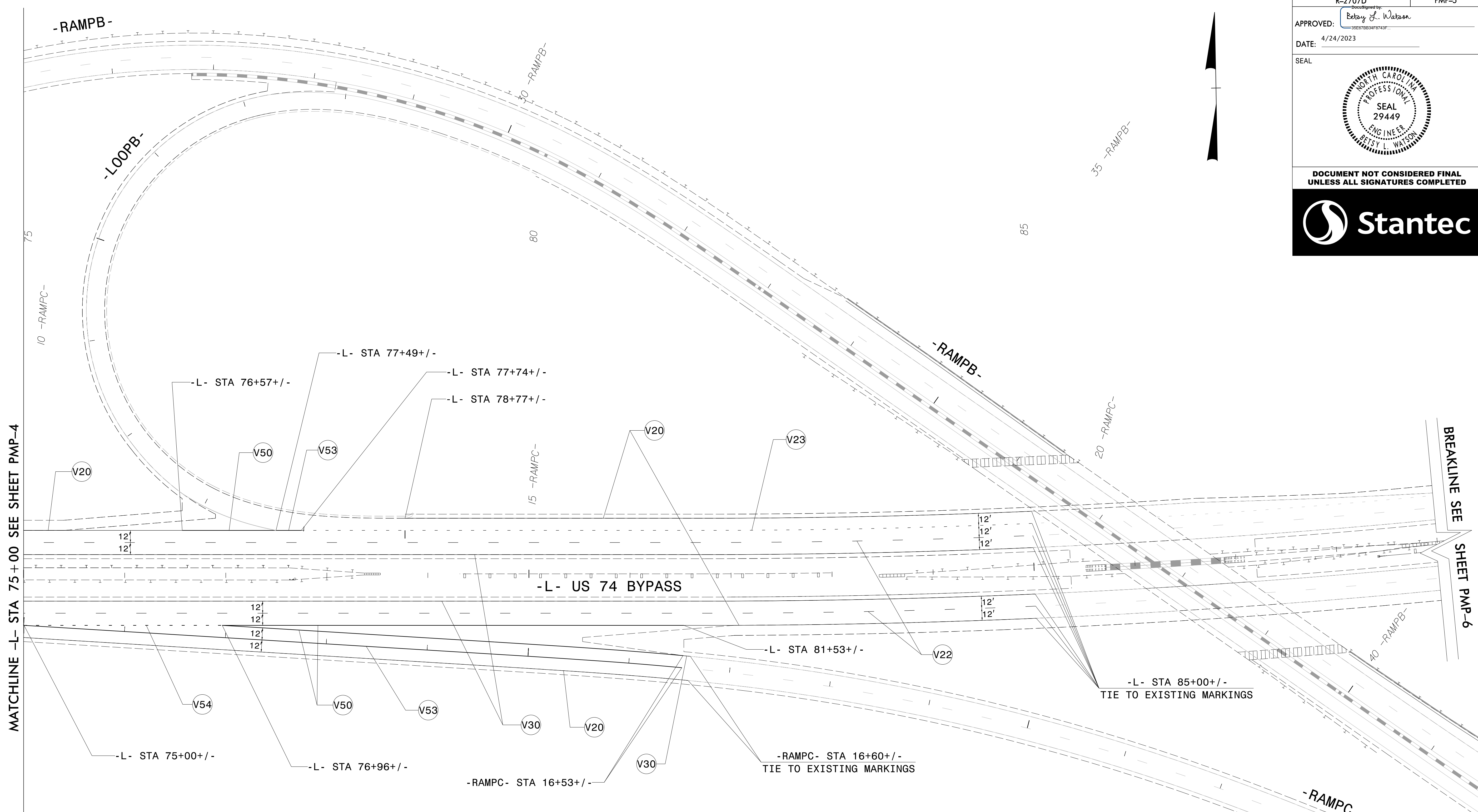

PAVEMENT MARKING DETAIL

\$\$\$\$\$SYTIME\$\$\$\$\$  
\$\$\$\$\$DGN\$\$\$\$\$  
\$\$\$\$\$USERNAME\$\$\$\$\$





TIP NO. R-2707D	SHEET NO. PMP-5
APPROVED: <i>Betsy L. Watson</i>	
DATE: 4/24/2023	
SEAL	
	
<p><b>DOCUMENT NOT CONSIDERED FINAL UNLESS ALL SIGNATURES COMPLETED</b></p> 	





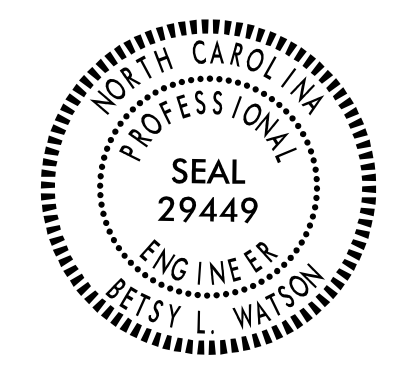

POLYUREA PAVEMENT MARKING LEGEND	
	WHITE EDGELINE (6")
	10 FT WHITE SKIP (6")
	3 FT-9 FT/SP WHITE MINISKIP (6")
	YELLOW EDGELINE (6")
	WHITE GORELINE (12")
	WHITE SOLID LANE LINE (12")
	3 FT-9 FT/SP WHITE MINISKIP (12")

**PAVEMENT MARKING DETAIL**

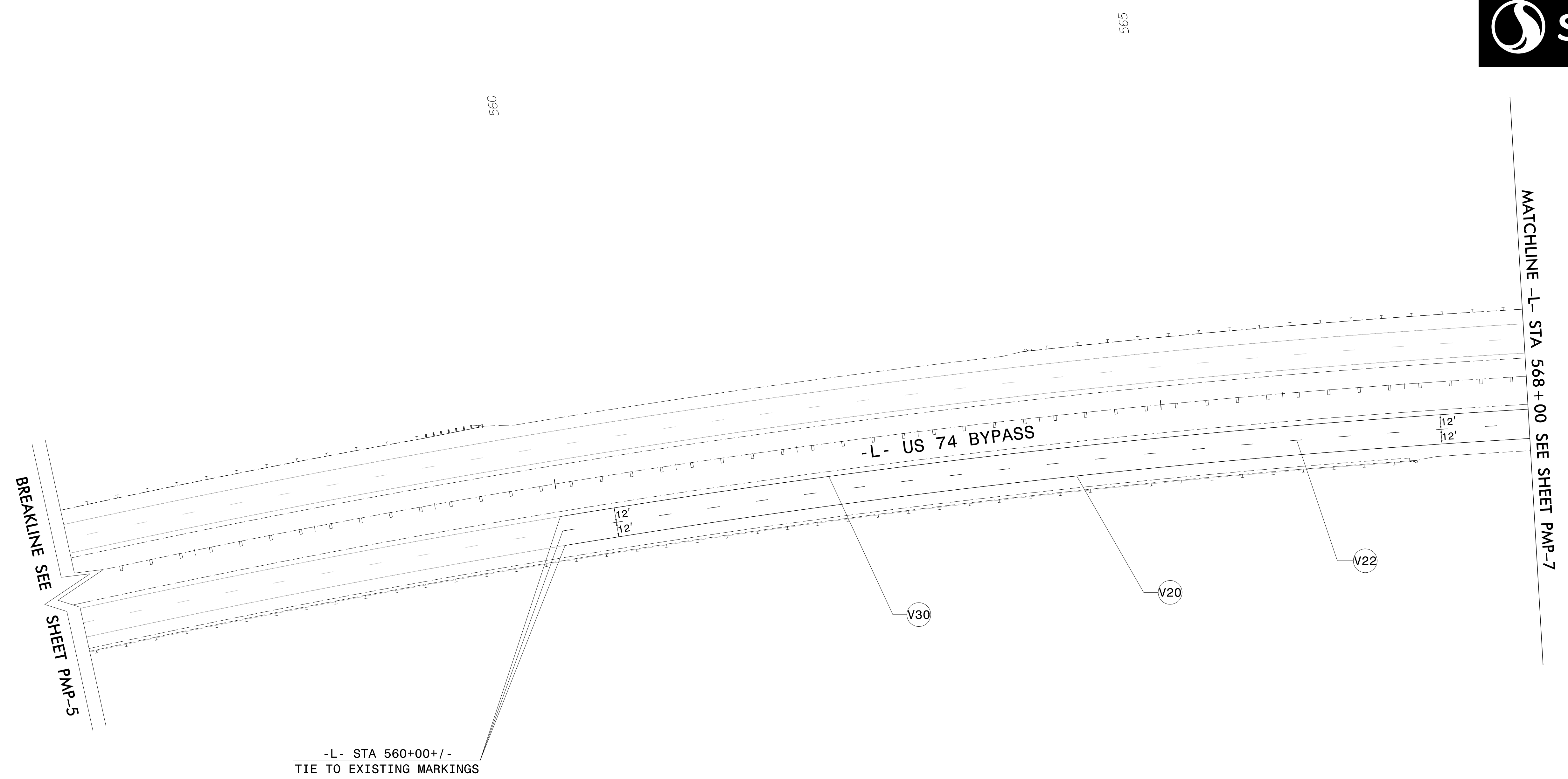
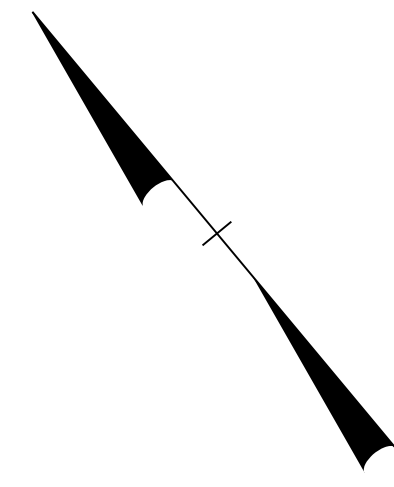
\$\$\$\$\$SYTIME\$\$\$\$\$  
 \$\$\$DDGN\$\$\$\$\$  
 \$\$\$USERNAME\$\$\$\$\$

TIP NO. R-2707D	SHEET NO. PMP-6
APPROVED: <i>Betsy L. Watson</i>	
DATE: 4/24/2023	
SEAL	
	
DOCUMENT NOT CONSIDERED FINAL UNLESS ALL SIGNATURES COMPLETED	
	





POLYUREA PAVEMENT MARKING LEGEND	
	WHITE EDGELINE (6")
	10 FT WHITE SKIP (6")
	YELLOW EDGELINE (6")

PAVEMENT MARKING DETAIL



\$\$\$\$\$SYTIME\$\$\$\$\$  
 \$\$\$\$\$\$DGN\$\$\$\$\$  
 \$\$\$\$\$\$USERNAME\$\$\$\$\$

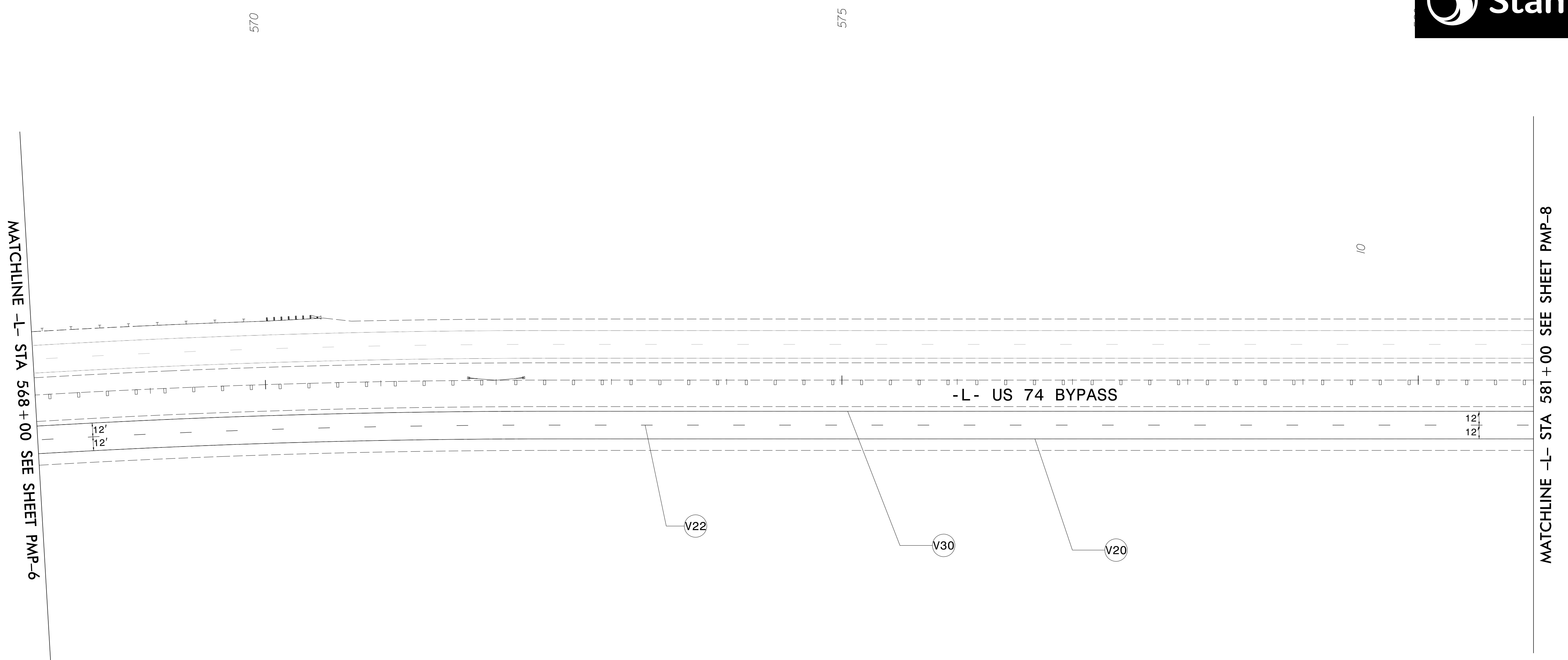
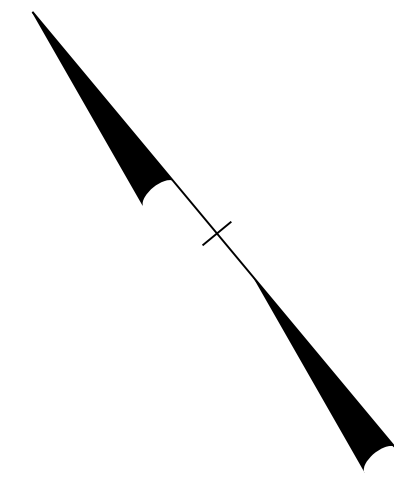

TIP NO. R-2707D	SHEET NO. PMP-7
APPROVED: <i>Betsy L. Watson</i>	
DATE: 4/24/2023	
SEAL	
	
DOCUMENT NOT CONSIDERED FINAL UNLESS ALL SIGNATURES COMPLETED	
	



\$\$\$\$\$SYTIME\$\$\$\$\$  
 \$\$\$DGN\$\$\$\$\$  
 \$\$\$USERNAME\$\$\$\$\$

POLYUREA PAVEMENT MARKING LEGEND	
	WHITE EDGELINE (6")
	10 FT WHITE SKIP (6")
	YELLOW EDGELINE (6")

PAVEMENT MARKING DETAIL

TIP NO. R-2707D	SHEET NO. PMP-8
APPROVED: <i>Betsy L. Watson</i>	
DATE: 4/24/2023	
SEAL	
DOCUMENT NOT CONSIDERED FINAL UNLESS ALL SIGNATURES COMPLETED	

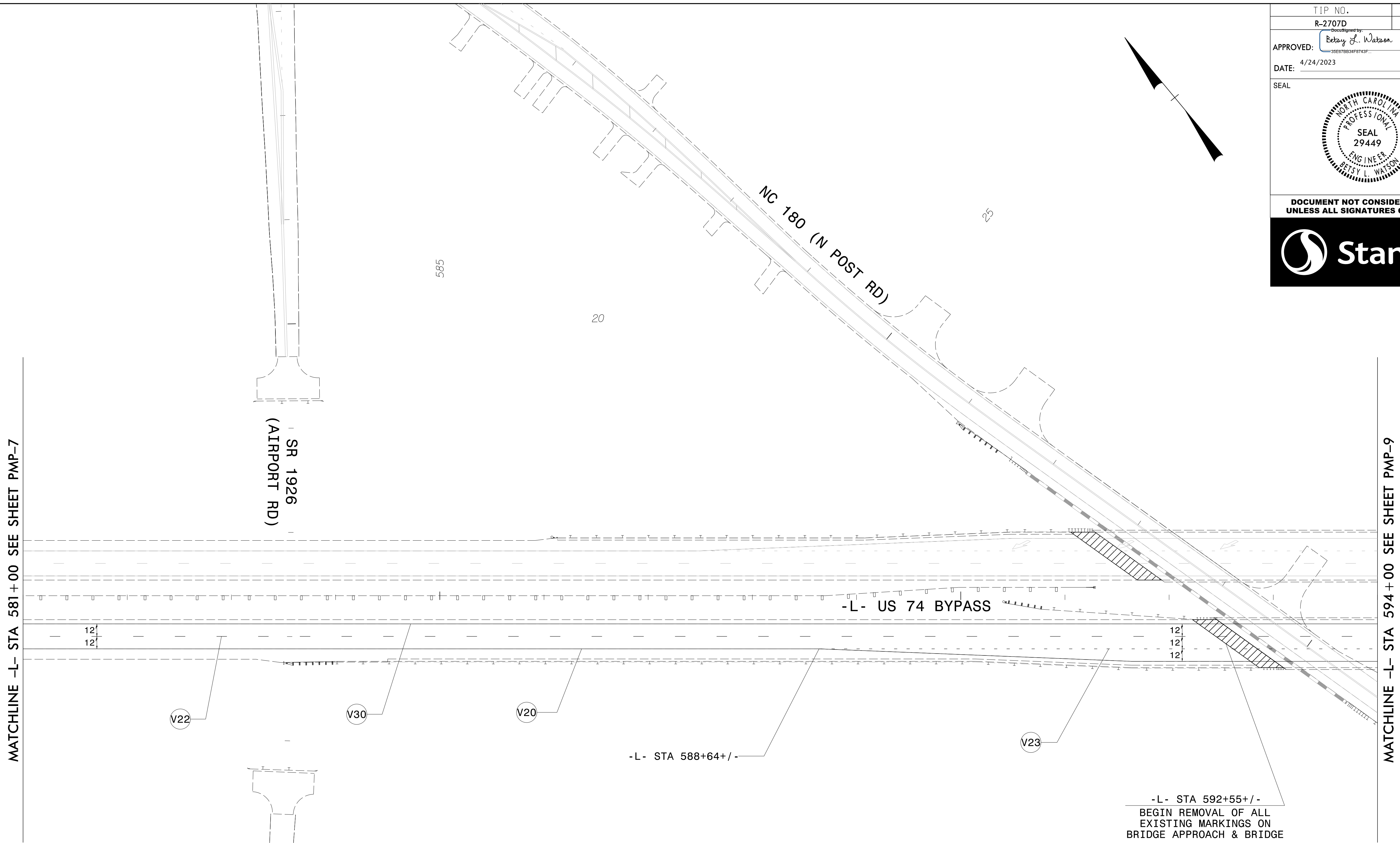
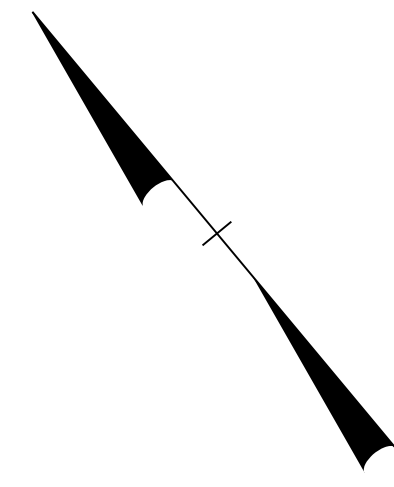

MATCHLINE -L- STA 581+00 SEE SHEET PMP-7

MATCHLINE -L- STA 594+00 SEE SHEET PMP-9

SR 1926  
(AIRPORT RD)

NC 180 (N POST RD)

-L- US 74 BYPASS

-L- STA 588+64+/-

-L- STA 592+55+/-  
BEGIN REMOVAL OF ALL  
EXISTING MARKINGS ON  
BRIDGE APPROACH & BRIDGE

POLYUREA PAVEMENT MARKING LEGEND	
	WHITE EDGELINE (6")
	10 FT WHITE SKIP (6")
	3 FT-9 FT/SP WHITE MINISKIP (6")
	YELLOW EDGELINE (6")

PAVEMENT MARKING DETAIL

\$\$\$\$\$SYTIME\$\$\$\$\$  
\$\$\$\$\$DDGN\$\$\$\$\$  
\$\$\$\$\$USERNAME\$\$\$\$\$



TIP NO. R-2707D	SHEET NO. PMP-9
APPROVED: <i>Betsy L. Watson</i> <small>35E67B3AF8743F</small>	
DATE: 4/26/2023	
SEAL	
DOCUMENT NOT CONSIDERED FINAL UNLESS ALL SIGNATURES COMPLETED	

**PROJECT NOTE**

REMOVAL OF SKINNY DRUMS WILL BE INCIDENTAL TO THE LINE ITEM  
MILLING ASPHALT PAVEMENT, 1.5 INCH DEPTH  
AND WILL BECOME THE PROPERTY OF THE CONTRACTOR

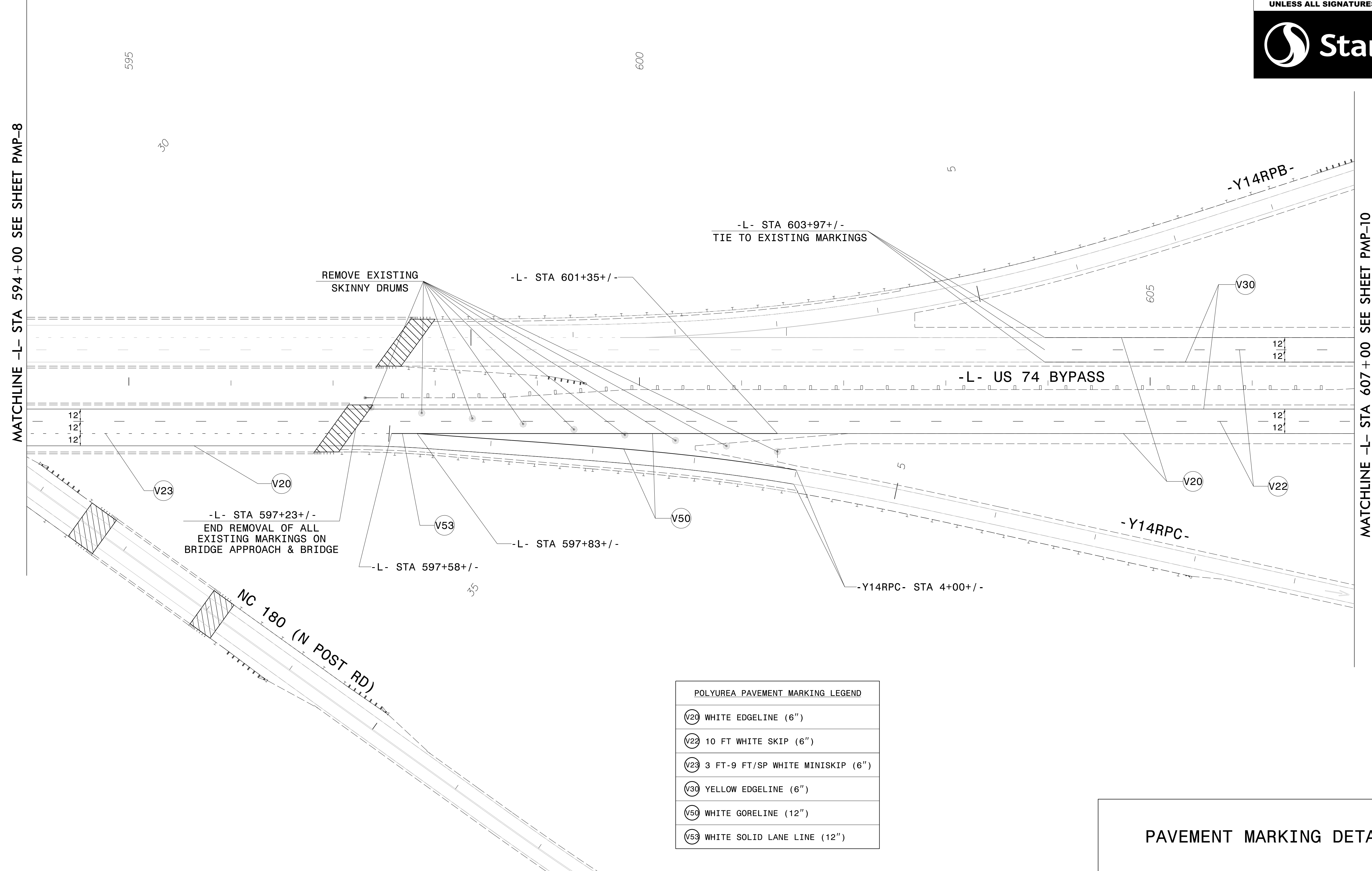
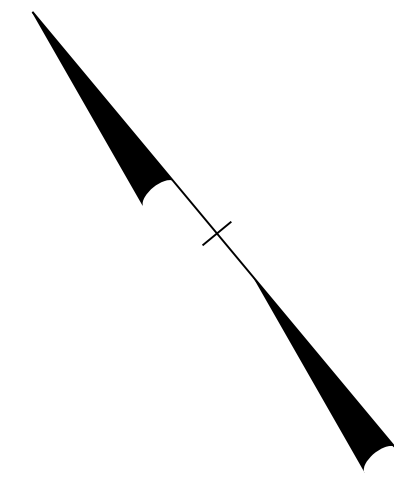

POLYUREA PAVEMENT MARKING LEGEND	
	WHITE EDGELINE (6")
	10 FT WHITE SKIP (6")
	3 FT-9 FT/SP WHITE MINISKIP (6")
	YELLOW EDGELINE (6")
	WHITE GORELINE (12")
	WHITE SOLID LANE LINE (12")

**PAVEMENT MARKING DETAIL**

\$\$\$\$\$SYTIME\$\$\$\$\$  
\$\$\$\$\$DDGN\$\$\$\$\$  
\$\$\$\$\$USERNAME\$\$\$\$\$

TIP NO. R-2707D	SHEET NO. PMP-10
APPROVED: <i>Betsy L. Watson</i>	
DATE: 4/24/2023	
SEAL	
<p><b>DOCUMENT NOT CONSIDERED FINAL UNLESS ALL SIGNATURES COMPLETED</b></p>	

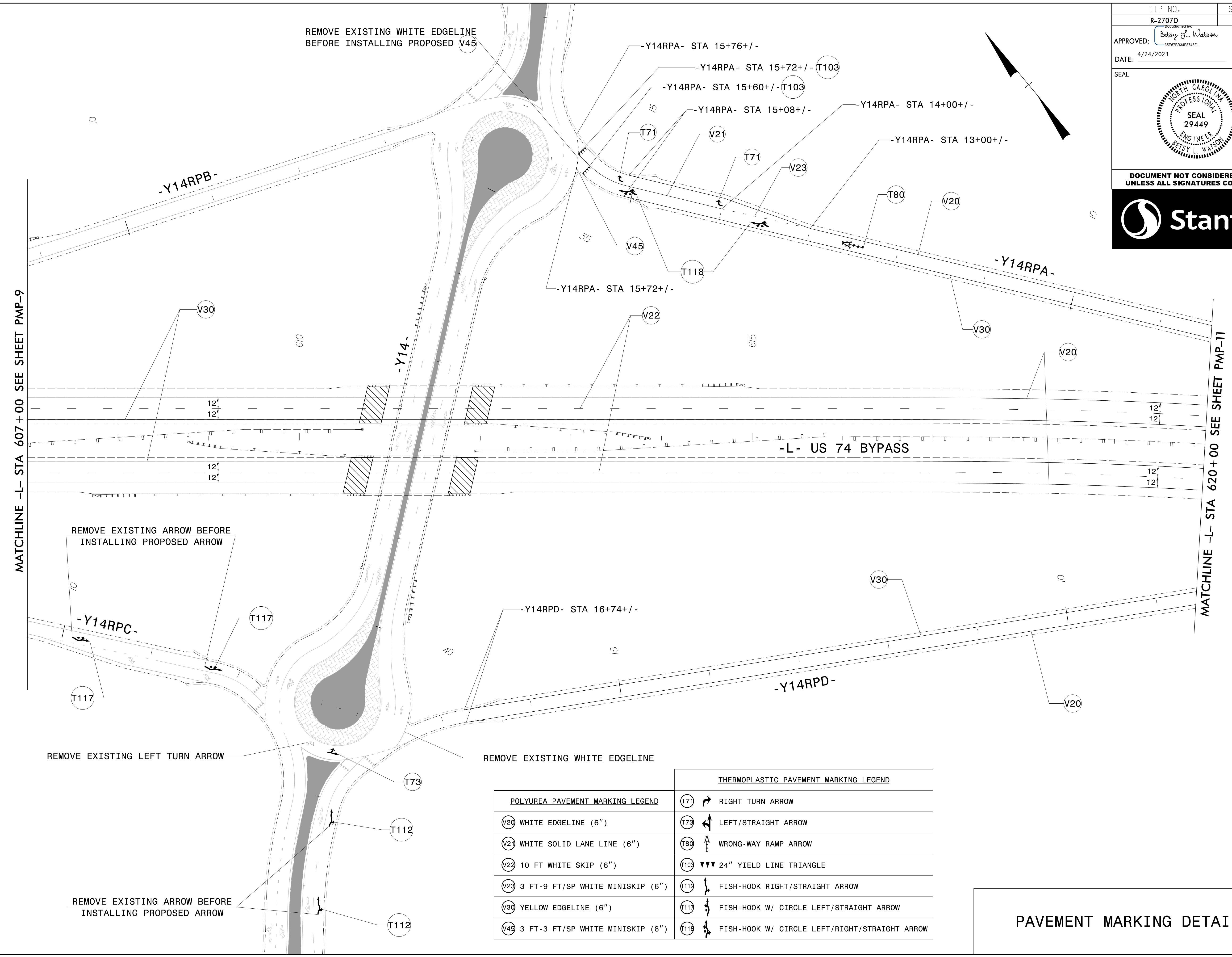



THERMOPLASTIC PAVEMENT MARKING LEGEND	
<b>POLYUREA PAVEMENT MARKING LEGEND</b>	(T71) RIGHT TURN ARROW
(V20) WHITE EDGELINE (6")	(T73) LEFT/STRAIGHT ARROW
(V21) WHITE SOLID LANE LINE (6")	(T80) WRONG-WAY RAMP ARROW
(V22) 10 FT WHITE SKIP (6")	(T103) 24" YIELD LINE TRIANGLE
(V23) 3 FT-9 FT/SP WHITE MINISKIP (6")	(T112) FISH-HOOK RIGHT/STRAIGHT ARROW
(V30) YELLOW EDGELINE (6")	(T117) FISH-HOOK W/ CIRCLE LEFT/STRAIGHT ARROW
(V45) 3 FT-3 FT/SP WHITE MINISKIP (8")	(T118) FISH-HOOK W/ CIRCLE LEFT/RIGHT/STRAIGHT ARROW

**PAVEMENT MARKING DETAIL**

\$\$\$\$\$SYTIME\$\$\$\$\$  
 \$\$\$\$\$\$DGN\$\$\$\$\$  
 \$\$\$\$\$\$USERNAME\$\$\$\$\$



TIP NO. R-2707D	SHEET NO. PMP-11
APPROVED: <i>Betsy L. Watson</i>	
DATE: 4/24/2023	
SEAL	
	
<p><b>DOCUMENT NOT CONSIDERED FINAL UNLESS ALL SIGNATURES COMPLETED</b></p> 	

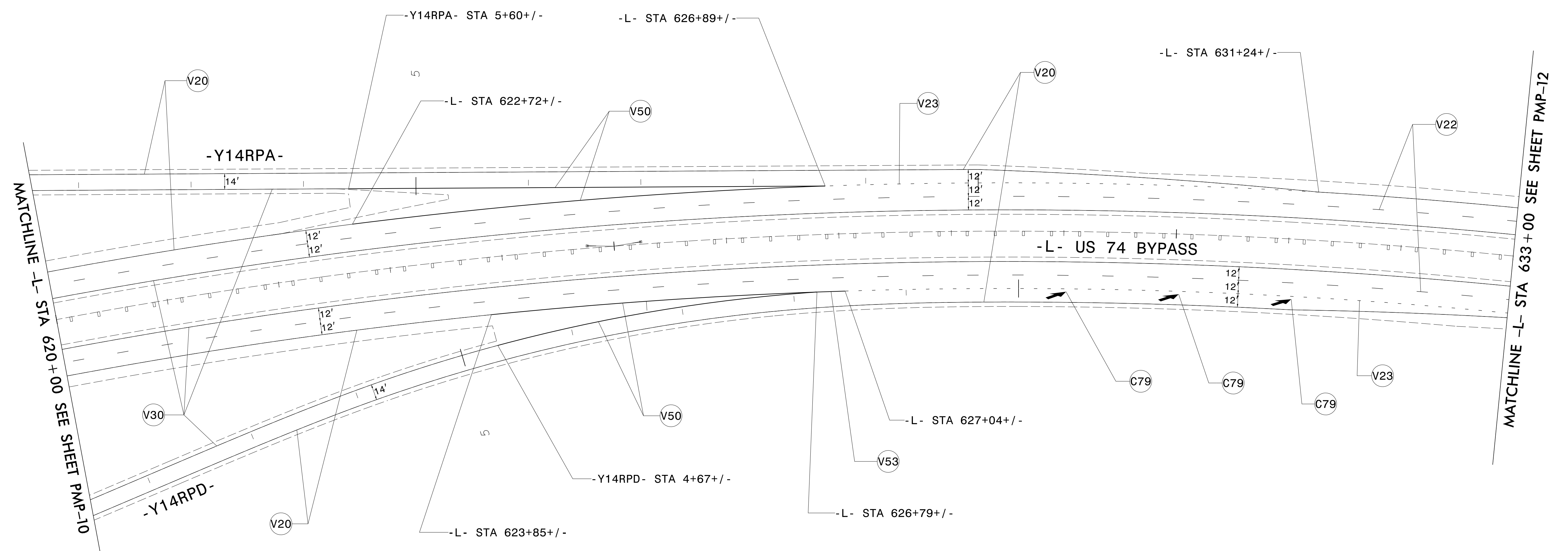
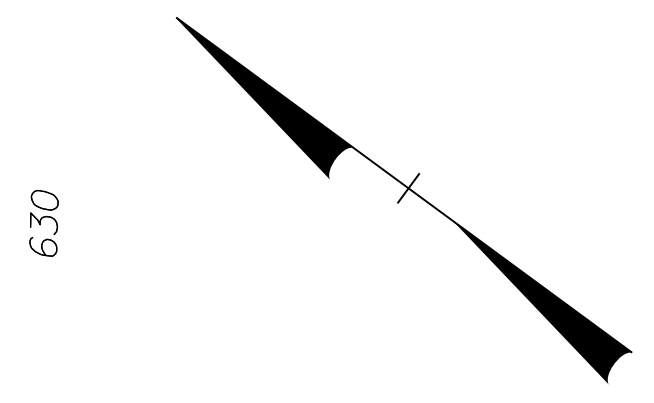



MATCHLINE -L- STA 620+00 SEE SHEET PMP-10

MATCHLINE -L- STA 633+00 SEE SHEET PMP-12





POLYUREA PAVEMENT MARKING LEGEND	COLD APPLIED PLASTIC PAVEMENT MARKING LEGEND
⊙V20 WHITE EDGELINE (6")	⊙C79 MERGE ARROW
⊙V22 10 FT WHITE SKIP (6")	
⊙V23 3 FT-9 FT/SP WHITE MINISKIP (6")	
⊙V30 YELLOW EDGELINE (6")	
⊙V50 WHITE GORELINE (12")	
⊙V53 WHITE SOLID LANE LINE (12")	

PAVEMENT MARKING DETAIL

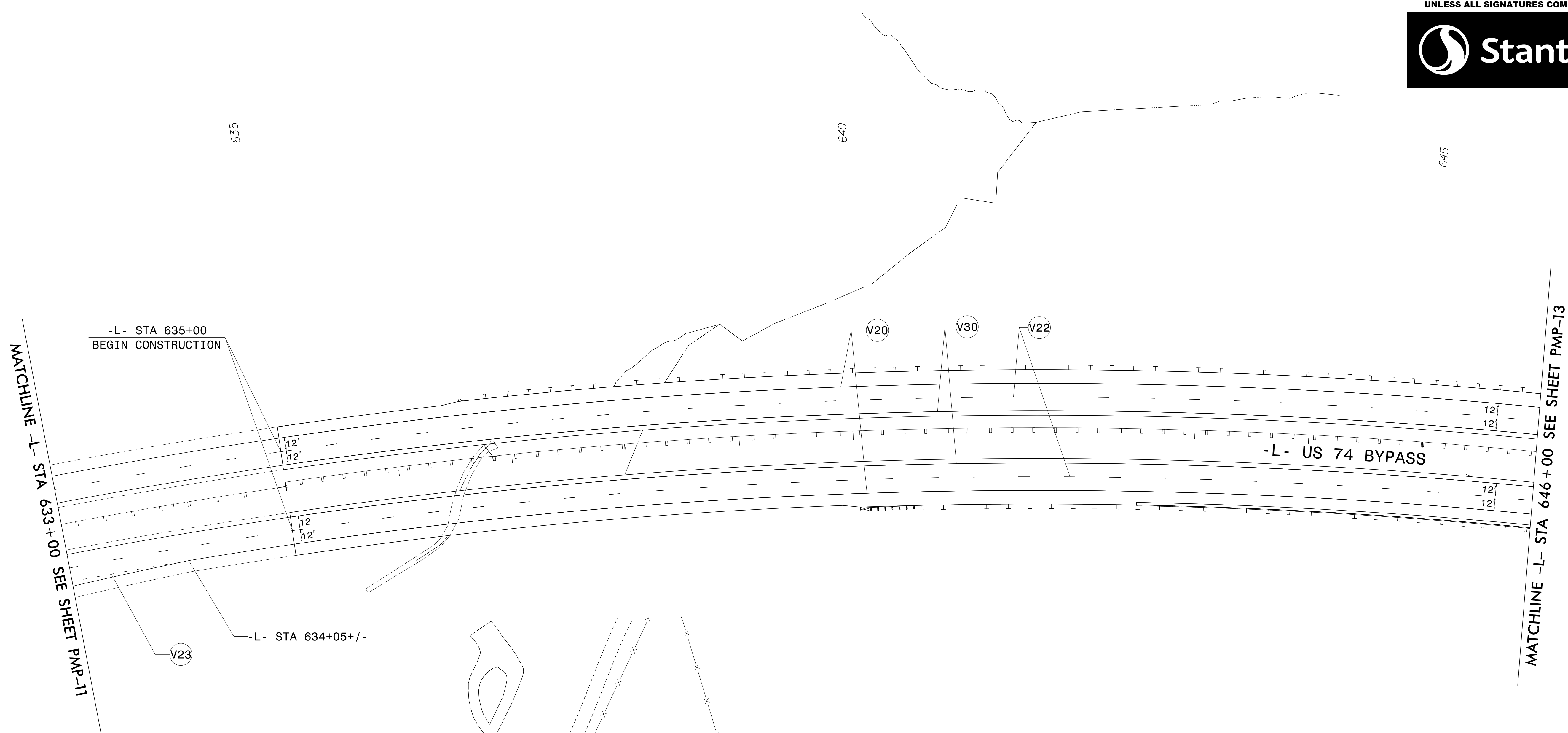
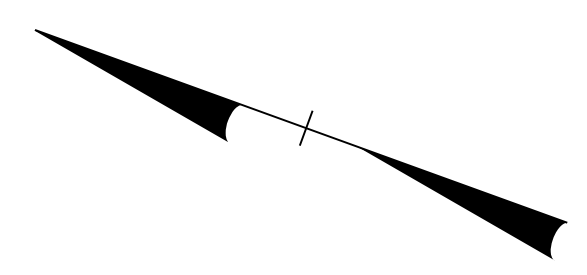
\$\$\$SYTIME\$\$\$\$  
 \$\$\$DGN\$\$\$\$  
 \$\$\$USERNAME\$\$\$\$

TIP NO. R-2707D	SHEET NO. PMP-12
APPROVED: <i>Betsy L. Watson</i>	
DATE: 4/24/2023	
SEAL	
	
DOCUMENT NOT CONSIDERED FINAL UNLESS ALL SIGNATURES COMPLETED	
	





POLYUREA PAVEMENT MARKING LEGEND	
	WHITE EDGELINE (6")
	10 FT WHITE SKIP (6")
	3 FT-9 FT/SP WHITE MINISKIP (6")
	YELLOW EDGELINE (6")

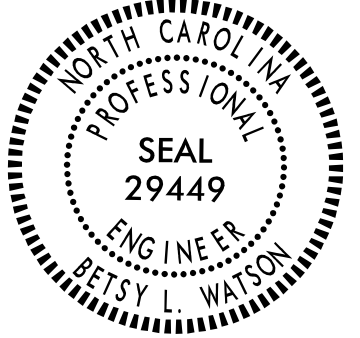

PAVEMENT MARKING DETAIL

\$\$\$\$\$SYTIME\$\$\$\$\$  
\$\$\$\$\$DGN\$\$\$\$\$  
\$\$\$\$\$USERNAME\$\$\$\$\$



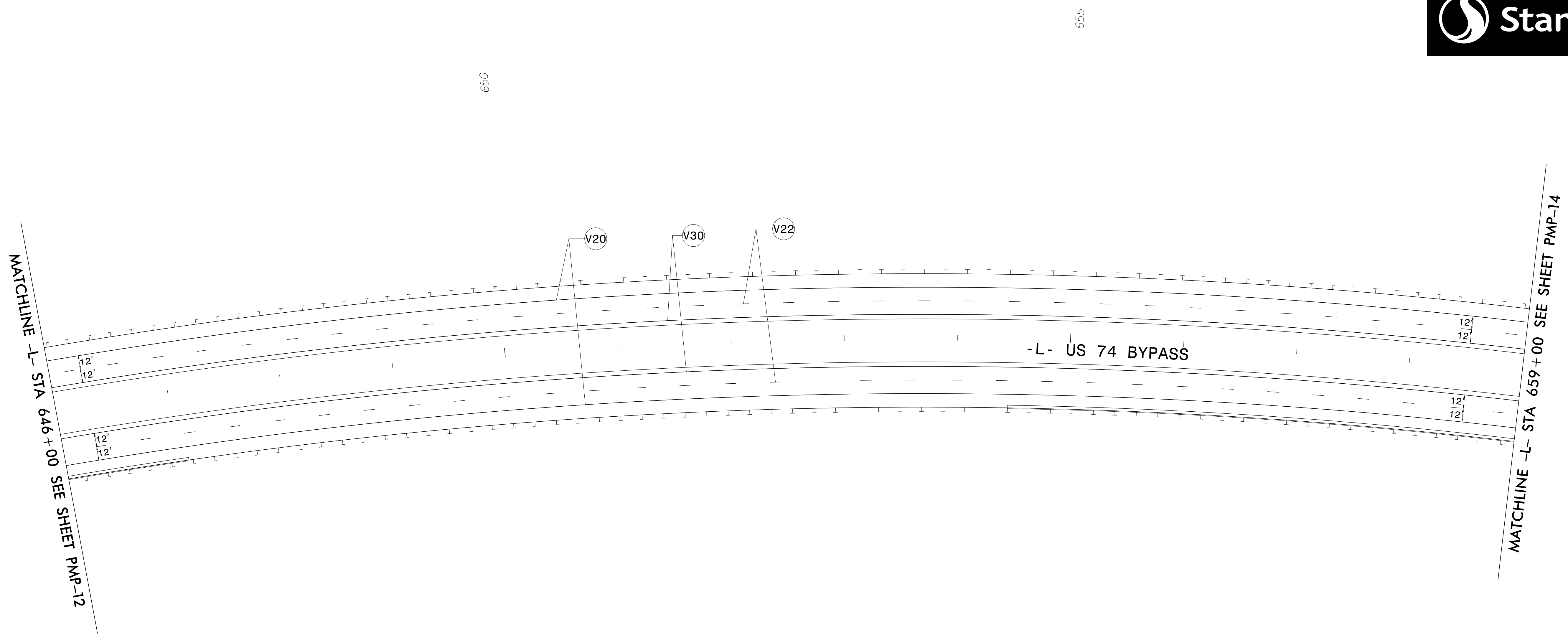
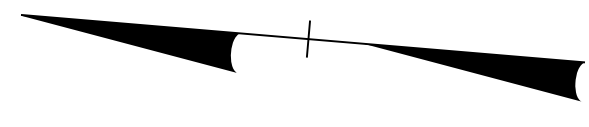

TIP NO. R-2707D	SHEET NO. PMP-13
APPROVED: <i>Betsy L. Watson</i>	
DATE: 4/24/2023	
SEAL	
	
DOCUMENT NOT CONSIDERED FINAL UNLESS ALL SIGNATURES COMPLETED	
	



POLYUREA PAVEMENT MARKING LEGEND	
	WHITE EDGELINE (6")
	10 FT WHITE SKIP (6")
	YELLOW EDGELINE (6")

PAVEMENT MARKING DETAIL

\$\$\$SYTIME\$\$\$\$  
 \$\$\$DGN\$\$\$\$  
 \$\$\$USERNAME\$\$\$\$

TIP NO. R-2707D	SHEET NO. PMP-14
APPROVED: <i>Betsy L. Watson</i>	
DATE: 4/24/2023	
SEAL	
	
<p><b>DOCUMENT NOT CONSIDERED FINAL UNLESS ALL SIGNATURES COMPLETED</b></p> 	

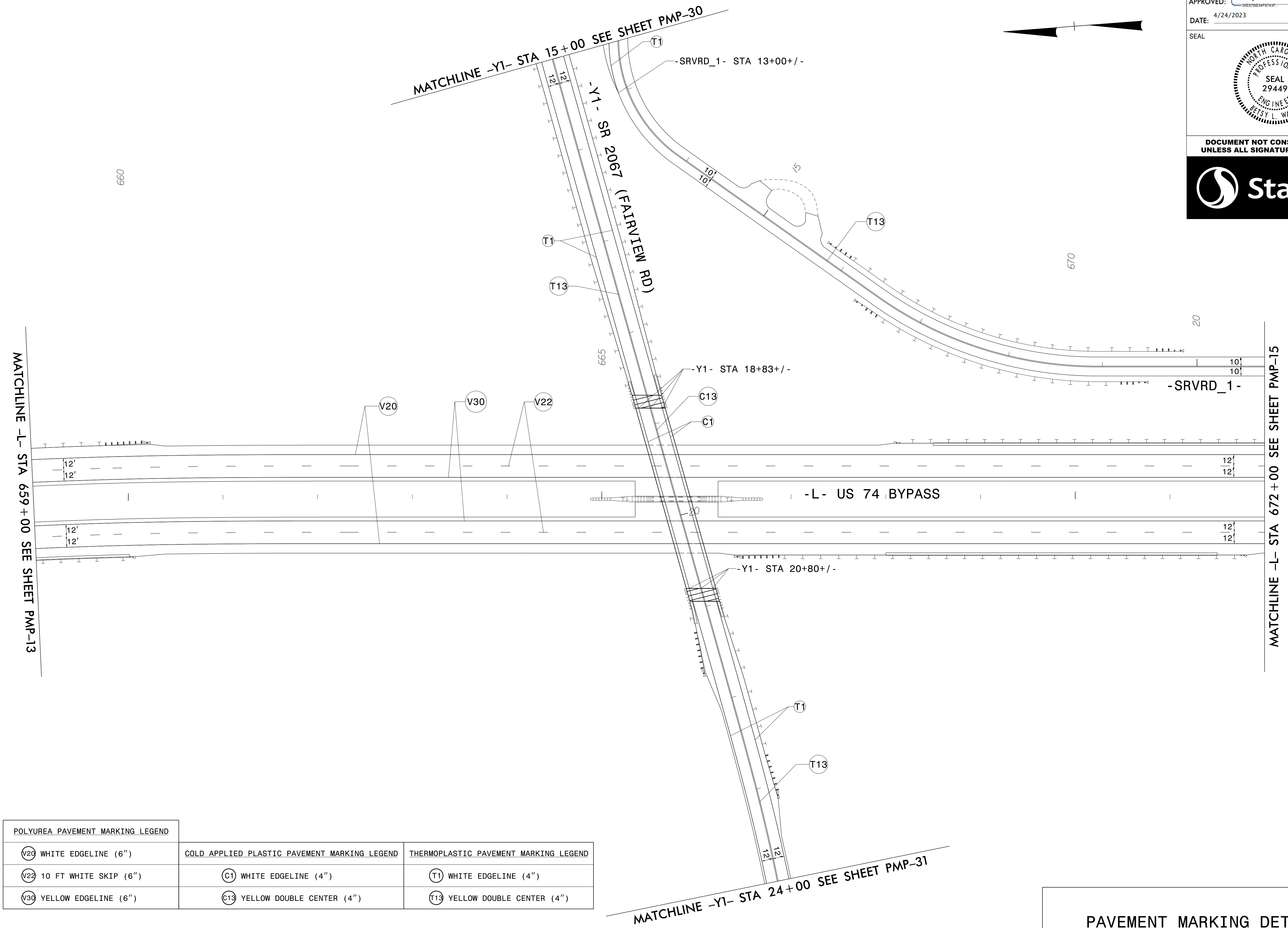



POLYUREA PAVEMENT MARKING LEGEND		
WHITE EDGELINE (6")	WHITE EDGELINE (4")	WHITE EDGELINE (4")
10 FT WHITE SKIP (6")	YELLOW DOUBLE CENTER (4")	YELLOW DOUBLE CENTER (4")
YELLOW EDGELINE (6")		





PAVEMENT MARKING DETAIL

\$\$\$SYTIME\$\$\$  
 \$\$\$DGN\$\$\$  
 \$\$\$USERNAME\$\$\$

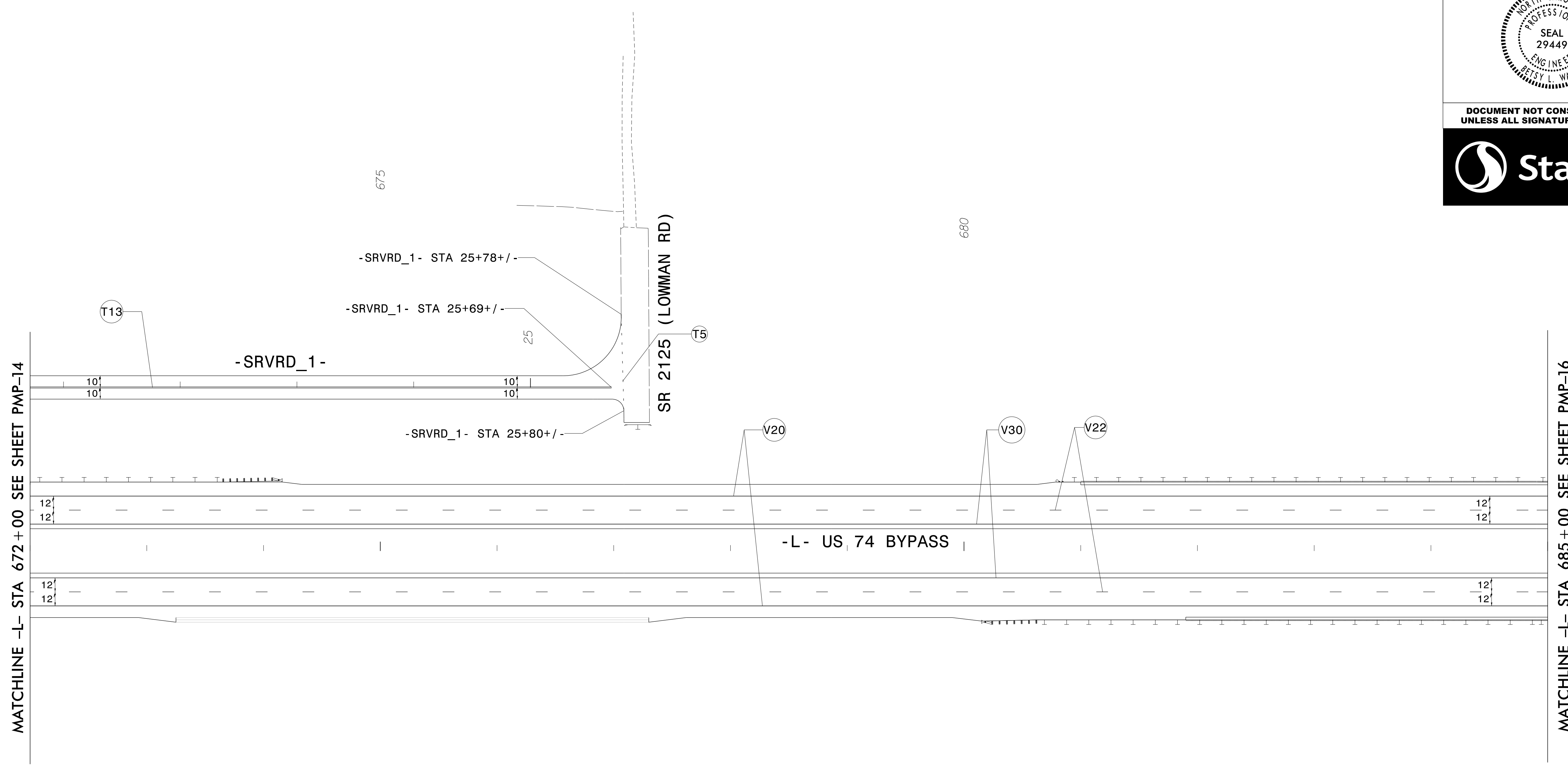
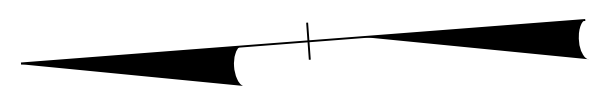

TIP NO. R-2707D	SHEET NO. PMP-15
APPROVED: <i>Betsy L. Watson</i>	
DATE: 4/24/2023	
SEAL	
	
<b>DOCUMENT NOT CONSIDERED FINAL UNLESS ALL SIGNATURES COMPLETED</b>	
	



POLYUREA PAVEMENT MARKING LEGEND		THERMOPLASTIC PAVEMENT MARKING LEGEND	
	WHITE EDGELINE (6")		2 FT-6 FT/SP WHITE MINISKIP (4")
	10 FT WHITE SKIP (6")		YELLOW DOUBLE CENTER (4")
	YELLOW EDGELINE (6")		

PAVEMENT MARKING DETAIL

\$\$\$SYTIME\$\$\$\$  
 \$\$\$DGN\$\$\$\$  
 \$\$\$USERNAME\$\$\$\$

TIP NO. R-2707D	SHEET NO. PMP-16
APPROVED: <i>Betsy L. Watson</i>	
DATE: 4/24/2023	
SEAL	
<p><b>DOCUMENT NOT CONSIDERED FINAL UNLESS ALL SIGNATURES COMPLETED</b></p>	

MATCHLINE -L- STA 685+00 SEE SHEET PMP-15

685

MATCHLINE -Y2- STA 24+00 SEE SHEET PMP-33

690

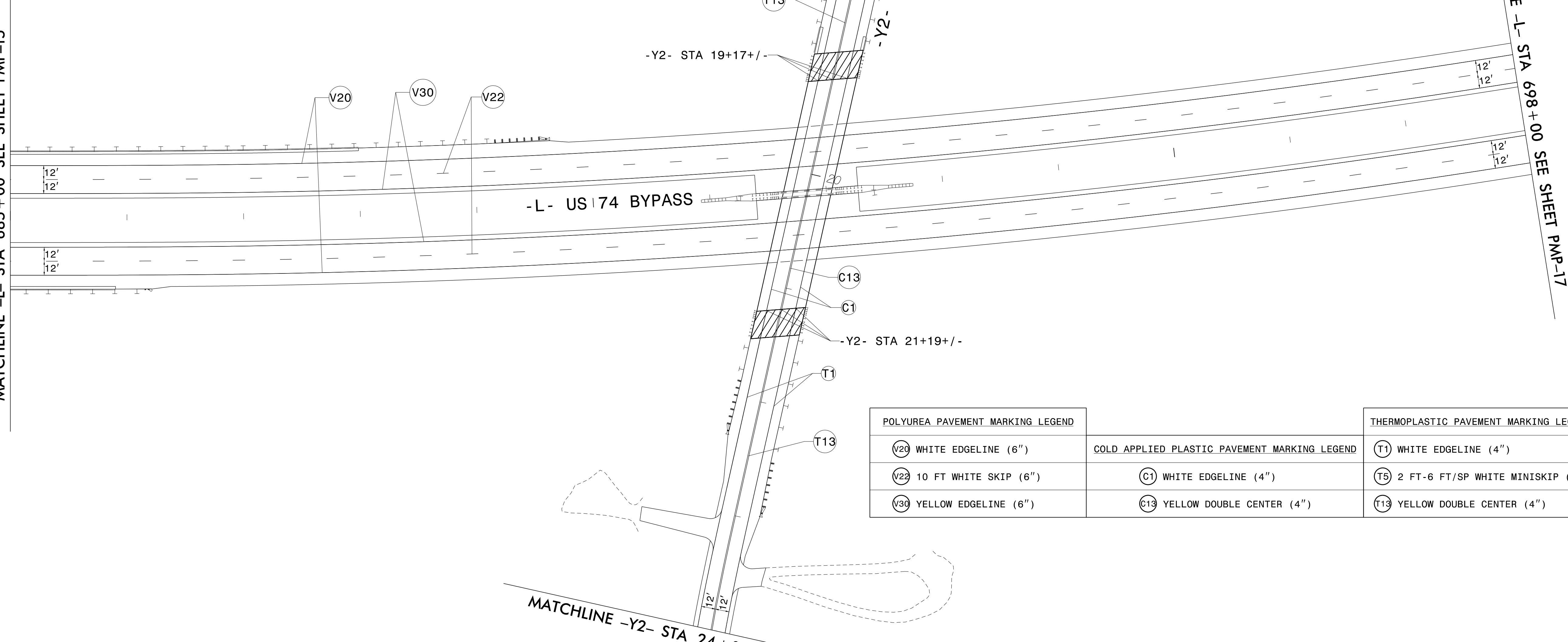
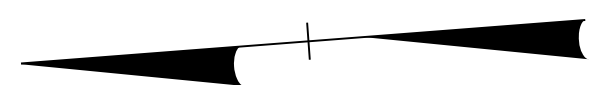



POLYUREA PAVEMENT MARKING LEGEND	
V20	WHITE EDGELINE (6")
V22	10 FT WHITE SKIP (6")
V30	YELLOW EDGELINE (6")

COLD APPLIED PLASTIC PAVEMENT MARKING LEGEND	
C1	WHITE EDGELINE (4")
C13	YELLOW DOUBLE CENTER (4")

THERMOPLASTIC PAVEMENT MARKING LEGEND	
T1	WHITE EDGELINE (4")
T5	2 FT-6 FT/SP WHITE MINISKIP (4")
T13	YELLOW DOUBLE CENTER (4")

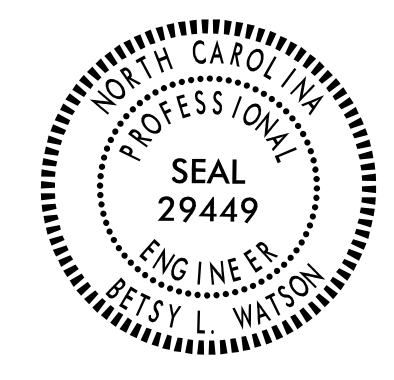

\$\$\$\$\$SYTIME\$\$\$\$\$  
\$\$\$\$\$DGN\$\$\$\$\$  
\$\$\$\$\$USERNAME\$\$\$\$\$

PAVEMENT MARKING DETAIL

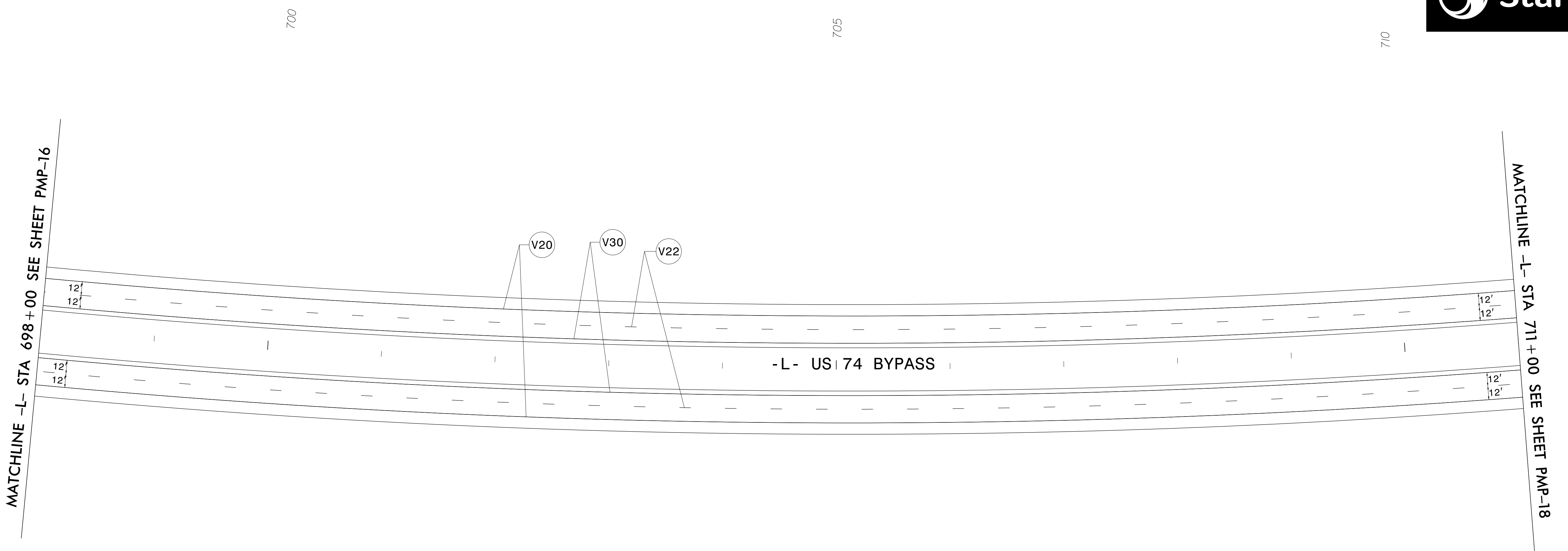
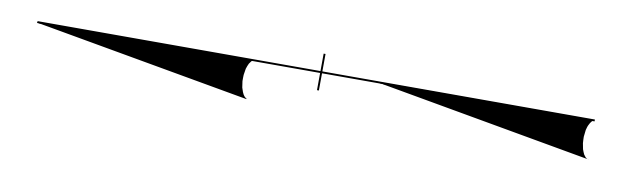
TIP NO. R-2707D	SHEET NO. PMP-17
APPROVED: <i>Betsy L. Watson</i>	
DATE: 4/24/2023	
SEAL	
	
DOCUMENT NOT CONSIDERED FINAL UNLESS ALL SIGNATURES COMPLETED	
	





\$\$\$\$\$SYTIME\$\$\$\$\$  
 \$\$\$\$\$\$DGN\$\$\$\$\$  
 \$\$\$\$\$\$USERNAME\$\$\$\$\$



POLYUREA PAVEMENT MARKING LEGEND	
	WHITE EDGELINE (6")
	10 FT WHITE SKIP (6")
	YELLOW EDGELINE (6")

PAVEMENT MARKING DETAIL



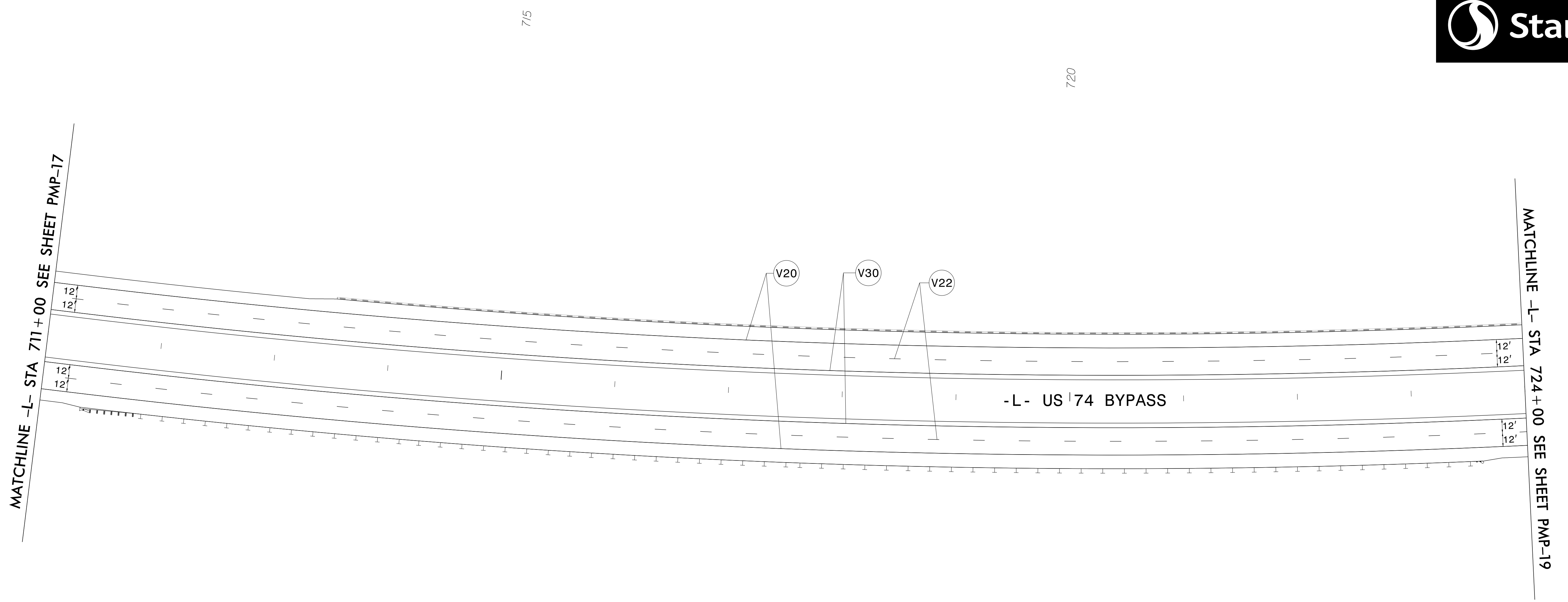
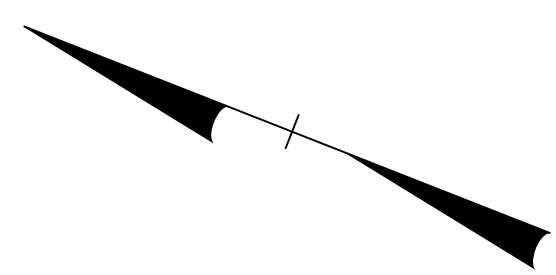

TIP NO. R-2707D	SHEET NO. PMP-18
APPROVED: <i>Betsy L. Watson</i>	
DATE: 4/24/2023	
SEAL	
	
DOCUMENT NOT CONSIDERED FINAL UNLESS ALL SIGNATURES COMPLETED	
	





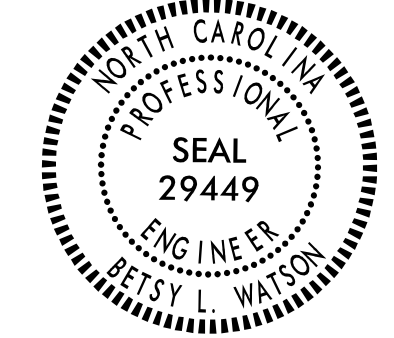

POLYUREA PAVEMENT MARKING LEGEND	
	WHITE EDGELINE (6")
	10 FT WHITE SKIP (6")
	YELLOW EDGELINE (6")

PAVEMENT MARKING DETAIL

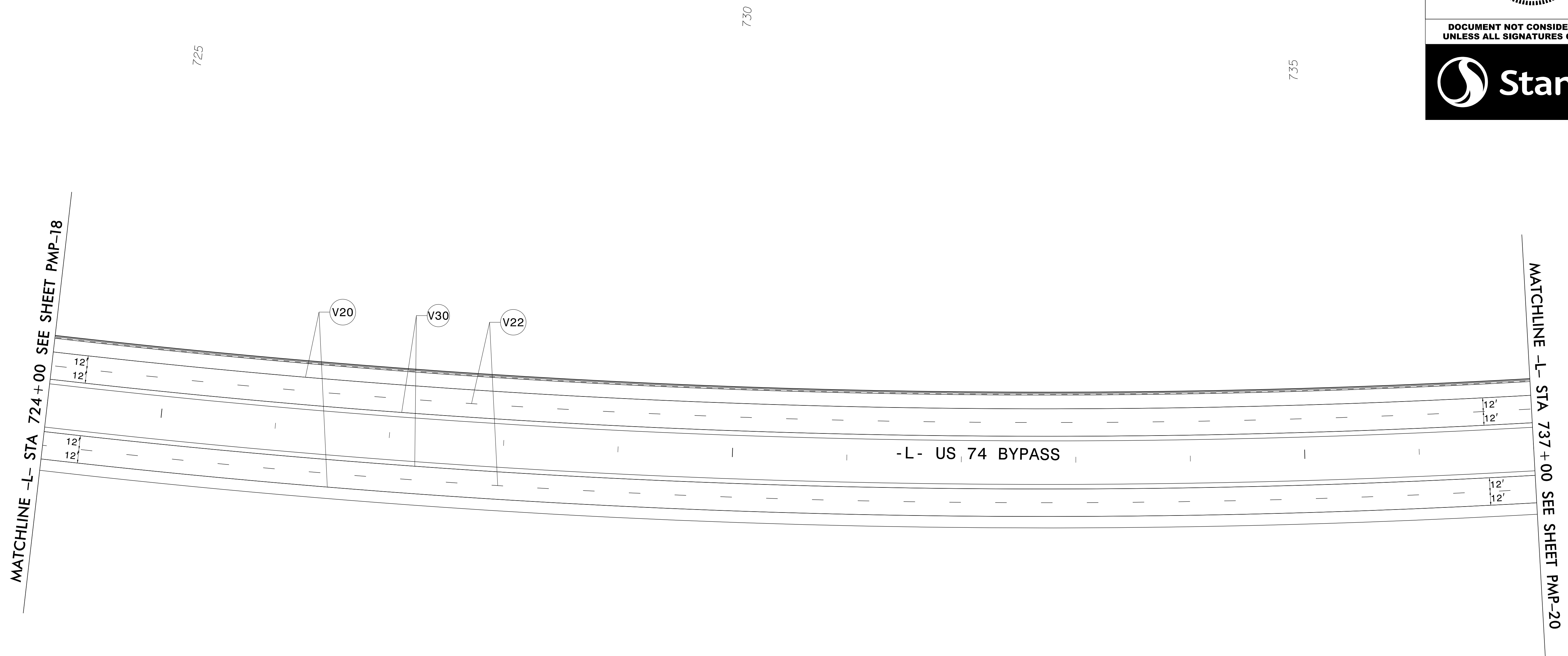
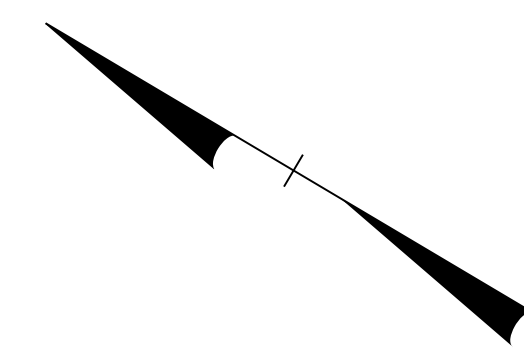
\$\$\$\$\$SYTIME\$\$\$\$\$  
 \$\$\$\$\$\$DGN\$\$\$\$\$  
 \$\$\$\$\$\$USERNAME\$\$\$\$\$



TIP NO. R-2707D	SHEET NO. PMP-19
APPROVED: <i>Betsy L. Watson</i>	
DATE: 4/24/2023	
SEAL	
	
DOCUMENT NOT CONSIDERED FINAL UNLESS ALL SIGNATURES COMPLETED	
	







POLYUREA PAVEMENT MARKING LEGEND	
	WHITE EDGELINE (6")
	10 FT WHITE SKIP (6")
	YELLOW EDGELINE (6")

PAVEMENT MARKING DETAIL

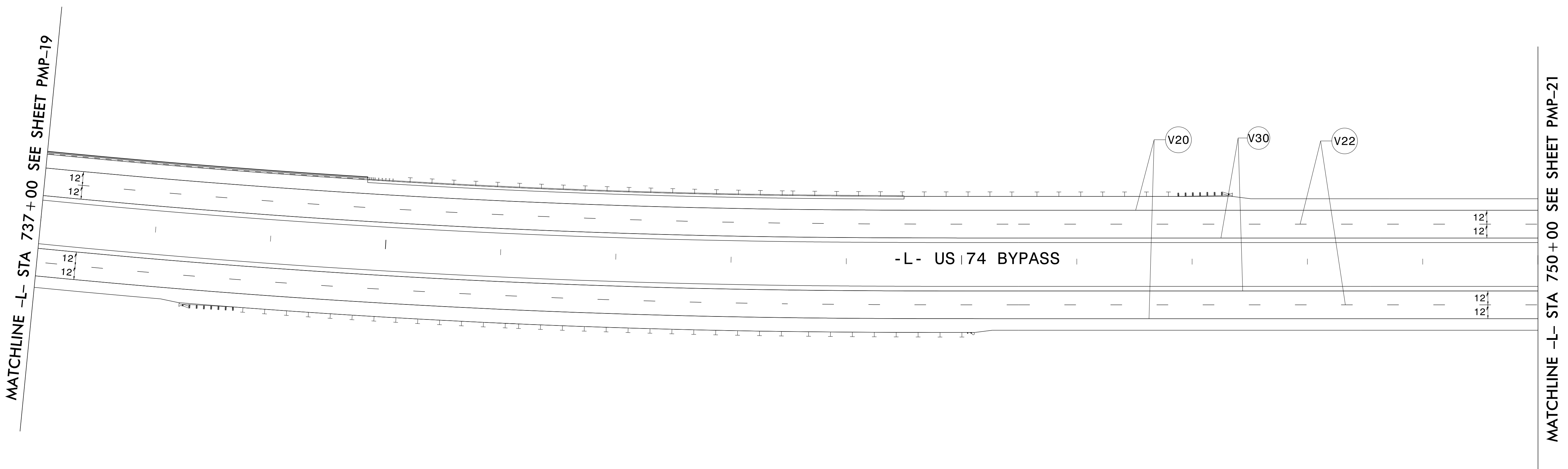
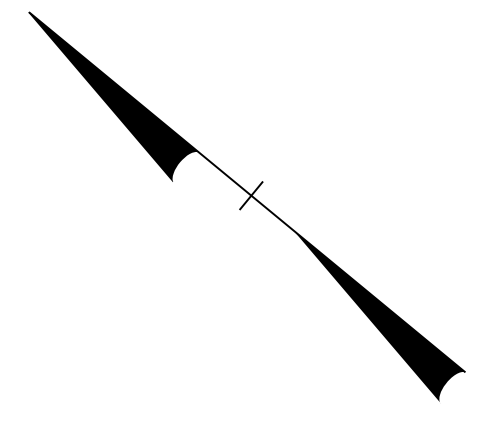
\$\$\$\$\$SYTIME\$\$\$\$\$  
\$\$\$\$\$DGN\$\$\$\$\$  
\$\$\$\$\$USERNAME\$\$\$\$\$

TIP NO. R-2707D	SHEET NO. PMP-20
APPROVED: <i>Betsy L. Watson</i>	
DATE: 4/24/2023	
SEAL	
	
DOCUMENT NOT CONSIDERED FINAL UNLESS ALL SIGNATURES COMPLETED	
	





POLYUREA PAVEMENT MARKING LEGEND	
	WHITE EDGELINE (6")
	10 FT WHITE SKIP (6")
	YELLOW EDGELINE (6")





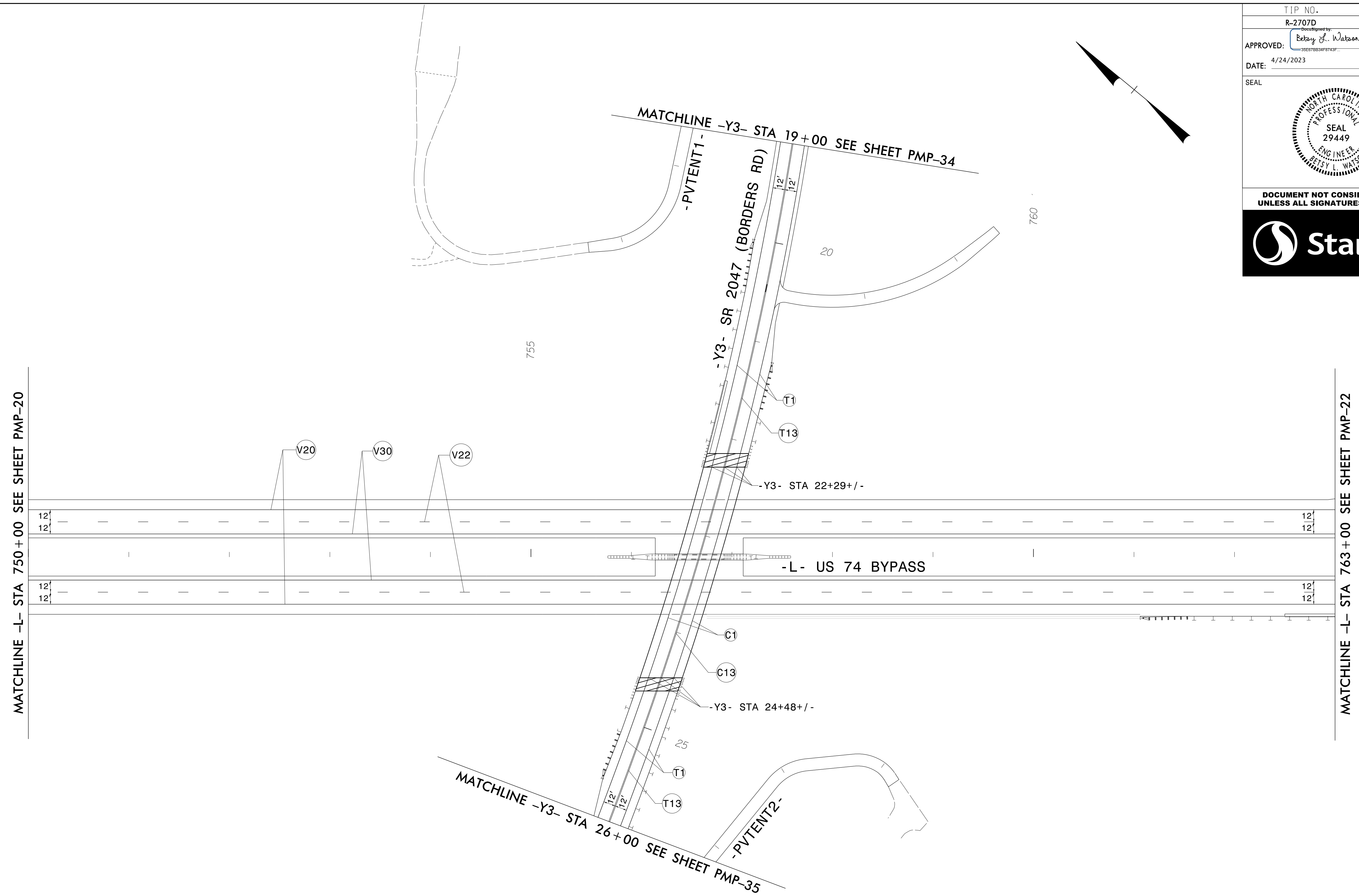

PAVEMENT MARKING DETAIL

\$\$\$\$\$SYTIME\$\$\$\$\$  
 \$\$\$\$\$\$DGN\$\$\$\$\$  
 \$\$\$\$\$\$USERNAME\$\$\$\$\$





TIP NO. R-2707D	SHEET NO. PMP-21
APPROVED: <i>Betsy L. Watson</i>	
DATE: 4/24/2023	
SEAL	
	
<p><b>DOCUMENT NOT CONSIDERED FINAL UNLESS ALL SIGNATURES COMPLETED</b></p> 	





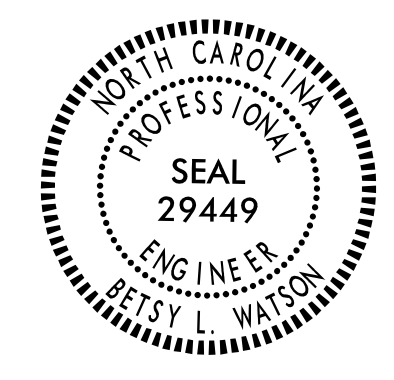

POLYUREA PAVEMENT MARKING LEGEND		
 V20	WHITE EDGELINE (6")	
 V22	10 FT WHITE SKIP (6")	
 V30	YELLOW EDGELINE (6")	
COLD APPLIED PLASTIC PAVEMENT MARKING LEGEND		
 C1	WHITE EDGELINE (4")	
 C13	YELLOW DOUBLE CENTER (4")	
THERMOPLASTIC PAVEMENT MARKING LEGEND		
 T1	WHITE EDGELINE (4")	
 T13	YELLOW DOUBLE CENTER (4")	

PAVEMENT MARKING DETAIL

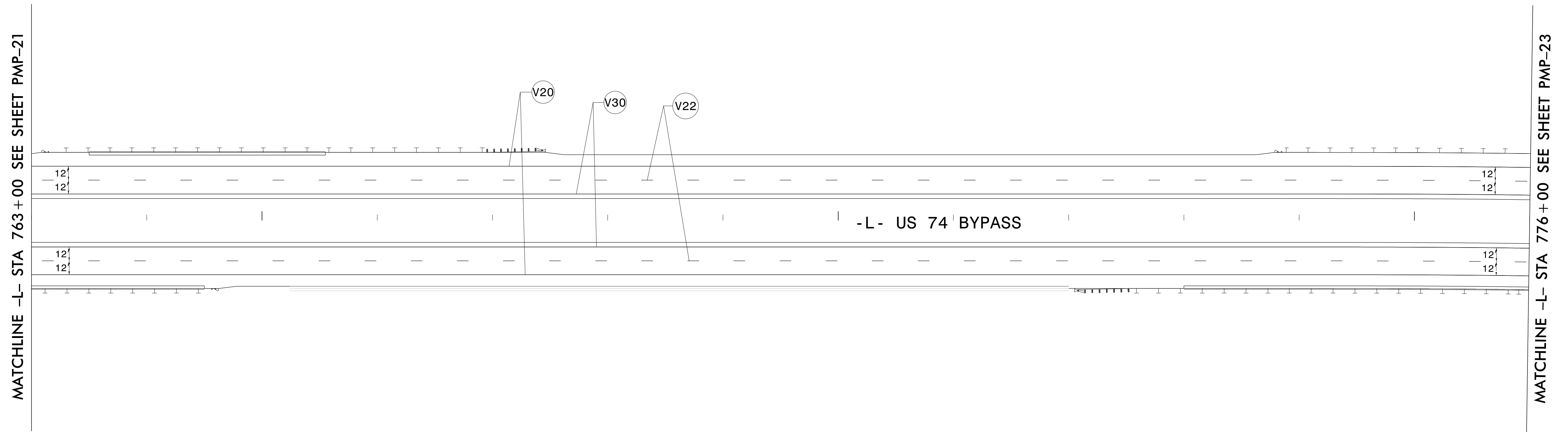
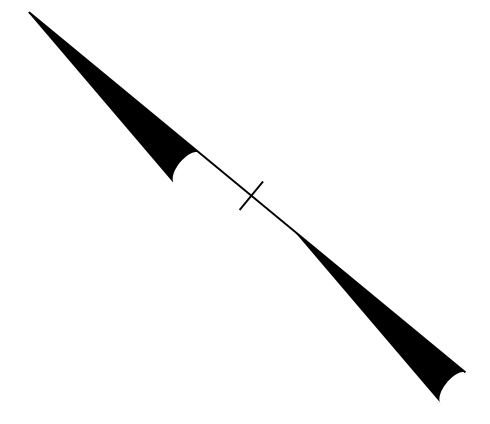
\$\$\$\$\$SYTIME\$\$\$\$\$  
 \$\$\$DGN\$\$\$\$\$  
 \$\$\$USERNAME\$\$\$\$\$



TIP NO. R-2707D	SHEET NO. PMP-22
APPROVED: <i>Betsy L. Watson</i>	
DATE: 4/24/2023	
SEAL	
	
DOCUMENT NOT CONSIDERED FINAL UNLESS ALL SIGNATURES COMPLETED	
	



POLYUREA PAVEMENT MARKING LEGEND	
	WHITE EDGELINE (6")
	10 FT WHITE SKIP (6")
	YELLOW EDGELINE (6")

PAVEMENT MARKING DETAIL

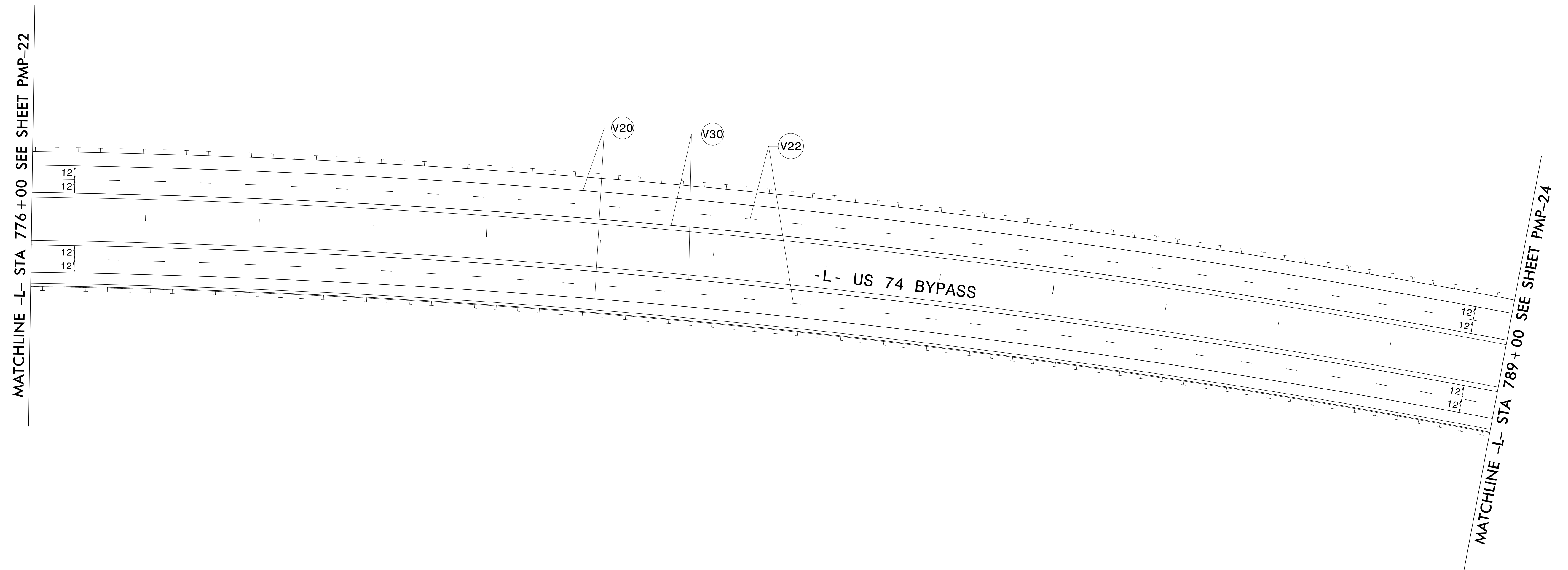
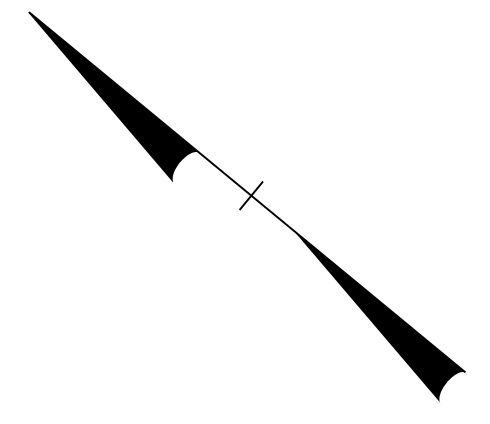

\$\$\$\$\$SYTIME\$\$\$\$\$  
 \$\$\$\$\$\$DGN\$\$\$\$\$  
 \$\$\$\$\$\$USERNAME\$\$\$\$\$

TIP NO. R-2707D	SHEET NO. PMP-23
APPROVED: <i>Betsy L. Watson</i>	
DATE: 4/24/2023	
SEAL	
	
DOCUMENT NOT CONSIDERED FINAL UNLESS ALL SIGNATURES COMPLETED	
	



780



785

POLYUREA PAVEMENT MARKING LEGEND	
	WHITE EDGELINE (6")
	10 FT WHITE SKIP (6")
	YELLOW EDGELINE (6")

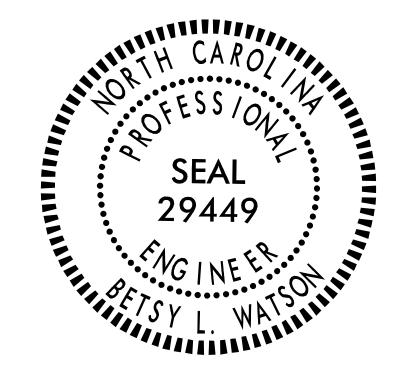

PAVEMENT MARKING DETAIL

\$\$\$\$\$SYTIME\$\$\$\$\$  
 \$\$\$\$\$\$DGN\$\$\$\$\$  
 \$\$\$\$\$\$USERNAME\$\$\$\$\$

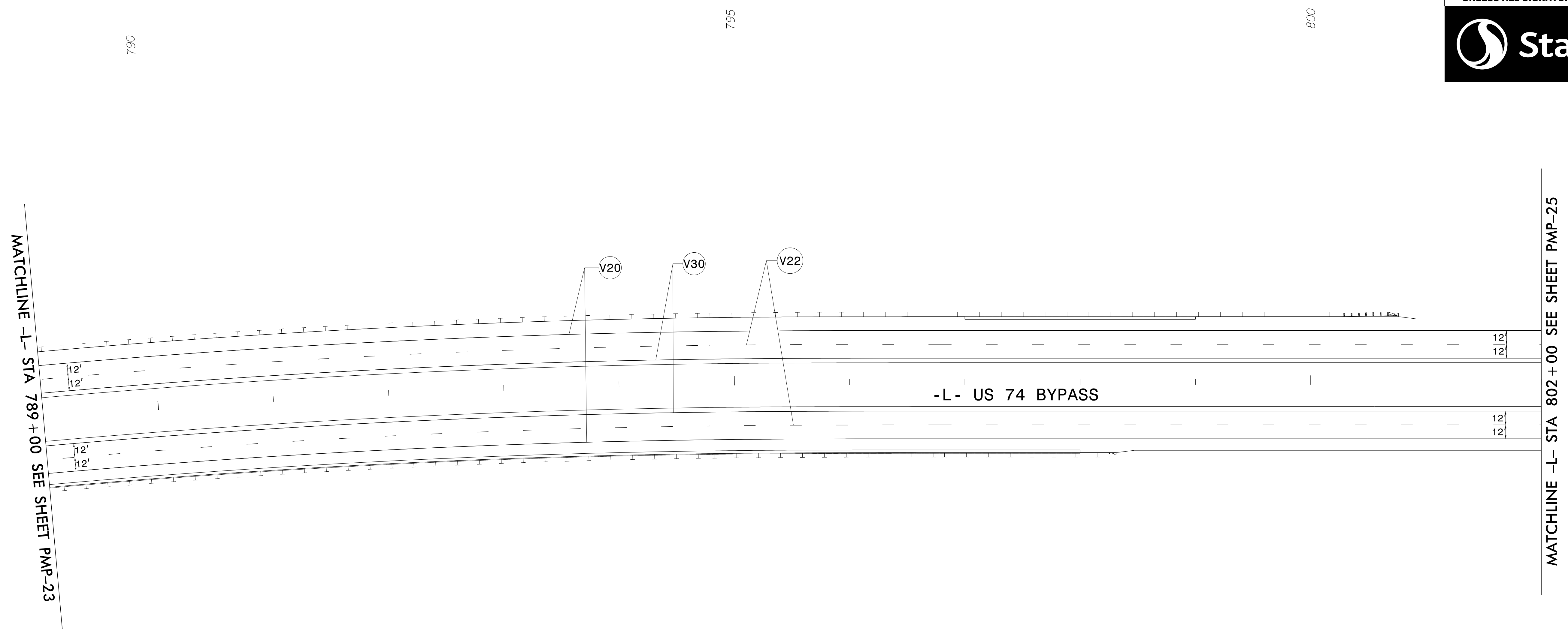
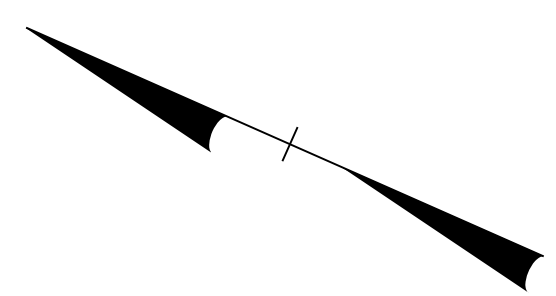

TIP NO. R-2707D	SHEET NO. PMP-24
APPROVED: <i>Betsy L. Watson</i>	
DATE: 4/24/2023	
SEAL	
	
DOCUMENT NOT CONSIDERED FINAL UNLESS ALL SIGNATURES COMPLETED	
	



POLYUREA PAVEMENT MARKING LEGEND	
	WHITE EDGELINE (6")
	10 FT WHITE SKIP (6")
	YELLOW EDGELINE (6")

PAVEMENT MARKING DETAIL

\$\$\$\$\$SYTIME\$\$\$\$\$  
 \$\$\$\$\$\$DGN\$\$\$\$\$  
 \$\$\$\$\$\$USERNAME\$\$\$\$\$

TIP NO. R-2707D	SHEET NO. PMP-25
APPROVED: <i>Betsy L. Watson</i>	
DATE: 4/24/2023	
SEAL	
<p><b>DOCUMENT NOT CONSIDERED FINAL UNLESS ALL SIGNATURES COMPLETED</b></p>	

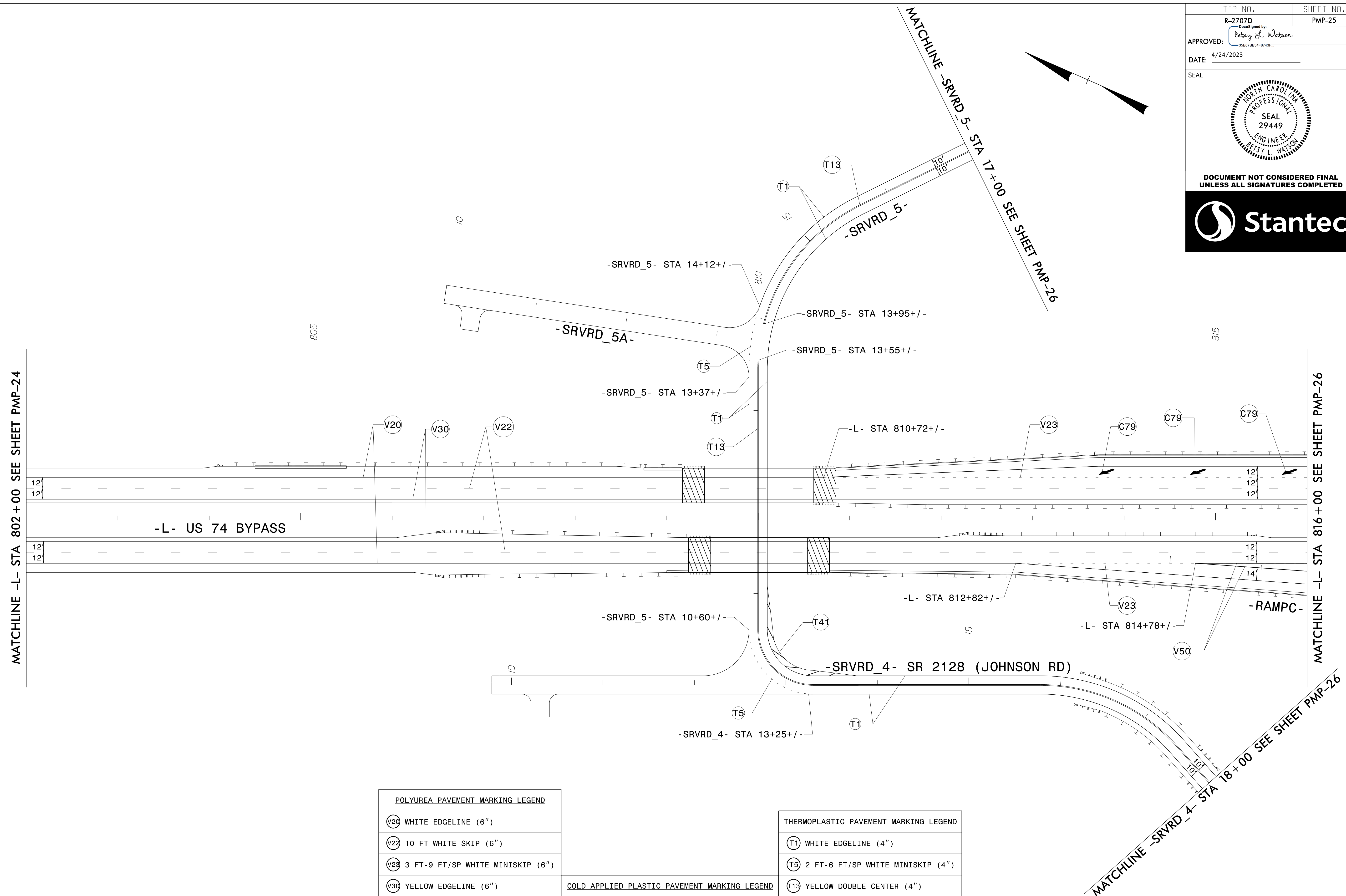

POLYUREA PAVEMENT MARKING LEGEND	
V20	WHITE EDGELINE (6")
V22	10 FT WHITE SKIP (6")
V23	3 FT-9 FT/SP WHITE MINISKIP (6")
V30	YELLOW EDGELINE (6")
V50	WHITE GORELINE (12")

COLD APPLIED PLASTIC PAVEMENT MARKING LEGEND	
C79	MERGE ARROW

THERMOPLASTIC PAVEMENT MARKING LEGEND	
T1	WHITE EDGELINE (4")
T5	2 FT-6 FT/SP WHITE MINISKIP (4")
T13	YELLOW DOUBLE CENTER (4")
T41	WHITE DIAGONAL (8")

\$\$\$\$\$SYTIME\$\$\$\$\$  
 \$\$\$DDGN\$\$\$\$\$  
 \$\$\$USERNAME\$\$\$\$\$

**PAVEMENT MARKING DETAIL**

POLYUREA PAVEMENT MARKING LEGEND	COLD APPLIED PLASTIC PAVEMENT MARKING LEGEND	THERMOPLASTIC PAVEMENT MARKING LEGEND
(V20) WHITE EDGELINE (6")	(C79) MERGE ARROW	(T1) WHITE EDGELINE (4")
(V22) 10 FT WHITE SKIP (6")		(T5) 2 FT-6 FT/SP WHITE MINISKIP (4")
(V23) 3 FT-9 FT/SP WHITE MINISKIP (6")		(T13) YELLOW DOUBLE CENTER (4")
(V30) YELLOW EDGELINE (6")		
(V50) WHITE GORELINE (12")		

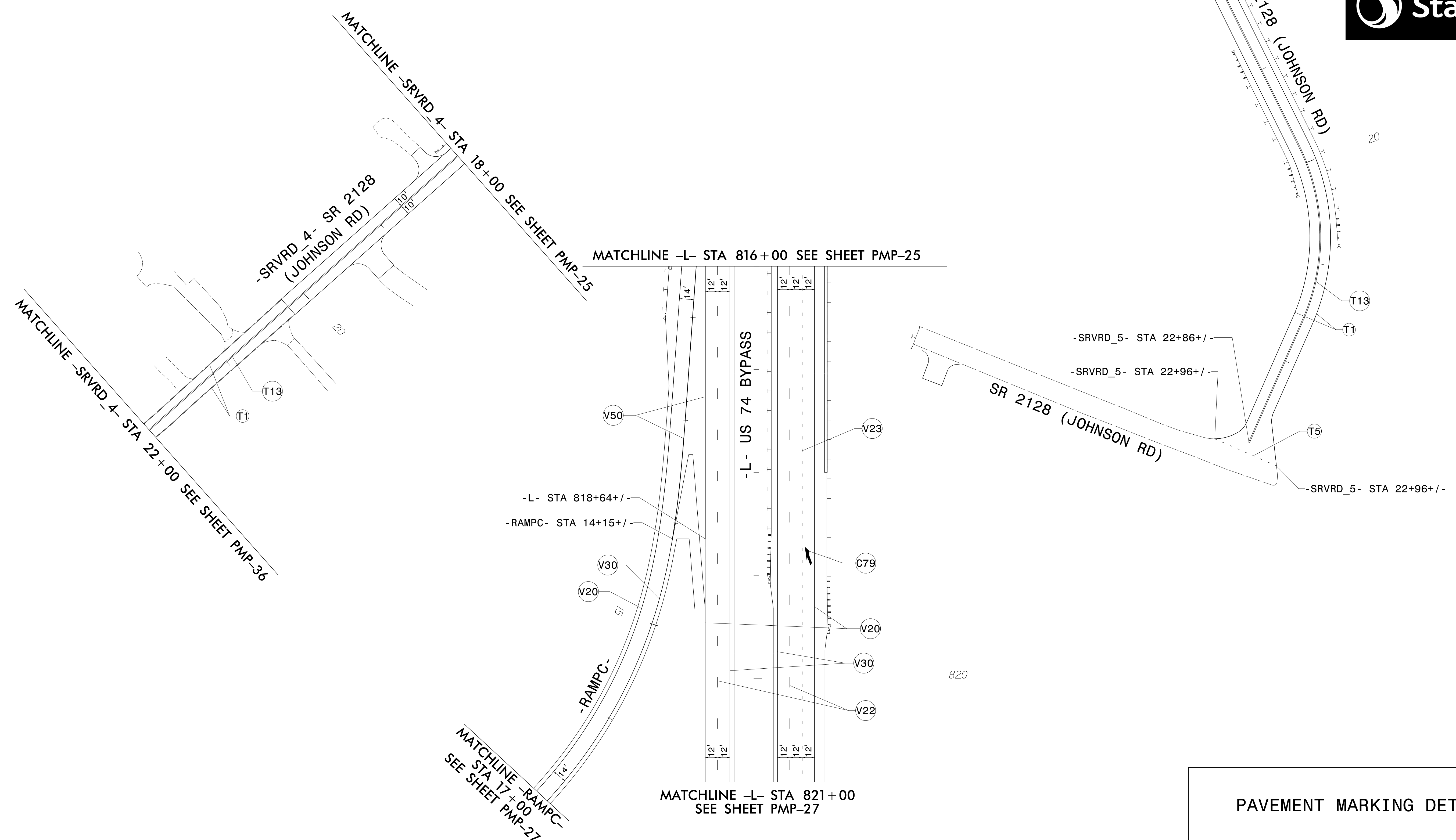

TIP NO. R-2707D	SHEET NO. PMP-26
APPROVED: <i>Petsy L. Watson</i>	
DATE: 4/24/2023	
SEAL	
	
<b>DOCUMENT NOT CONSIDERED FINAL UNLESS ALL SIGNATURES COMPLETED</b>	



\$\$\$\$\$SYTIME\$\$\$\$\$  
 \$\$\$\$\$\$DGN\$\$\$\$\$  
 \$\$\$\$\$\$USERNAME\$\$\$\$\$

**PAVEMENT MARKING DETAIL**



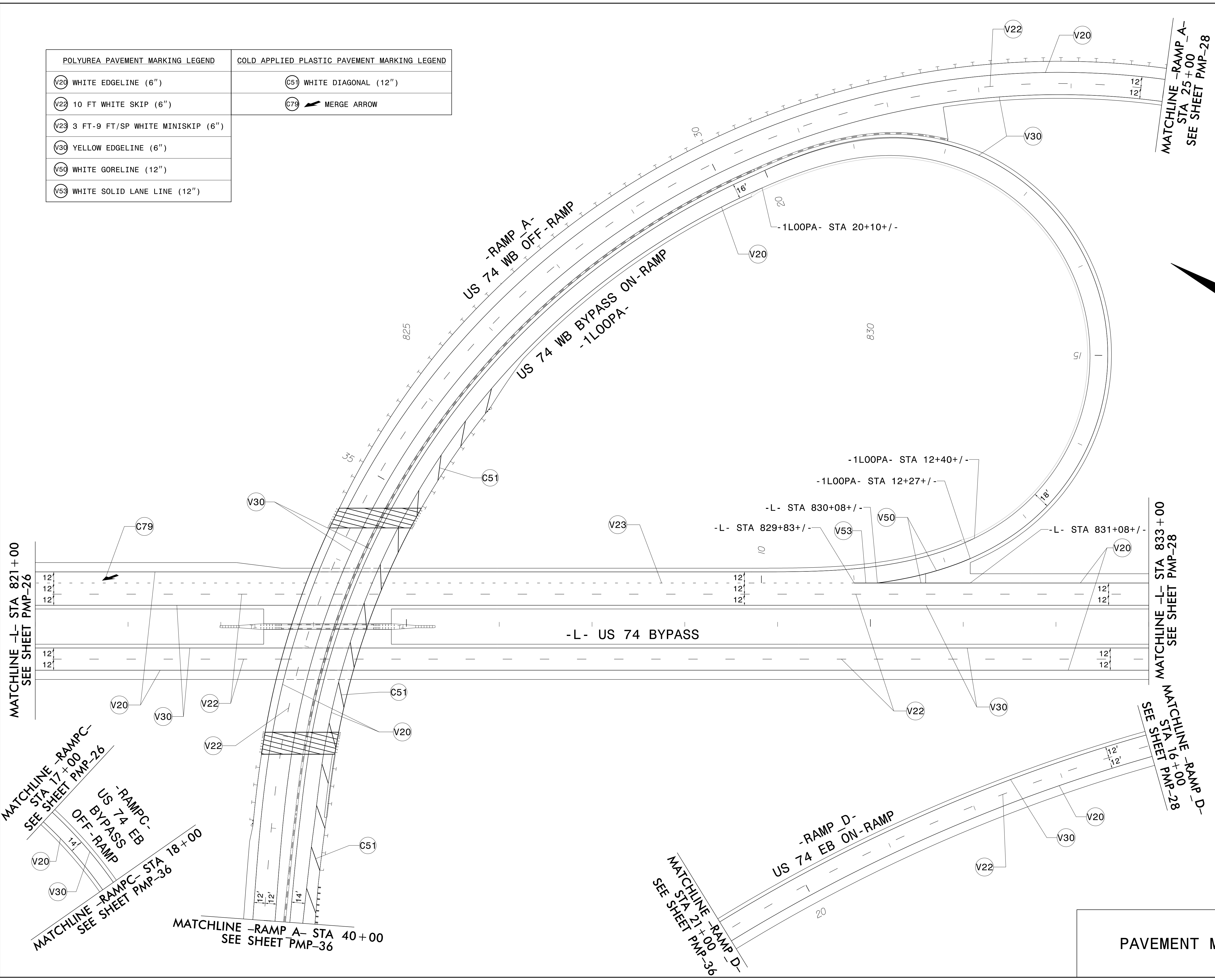

TIP NO. R-2707D	SHEET NO. PMP-27
APPROVED: <i>Betsy L. Watson</i>	
DATE: 4/24/2023	
SEAL	
	
<p><b>DOCUMENT NOT CONSIDERED FINAL UNLESS ALL SIGNATURES COMPLETED</b></p> 	

POLYUREA PAVEMENT MARKING LEGEND	COLD APPLIED PLASTIC PAVEMENT MARKING LEGEND
(V20) WHITE EDGELINE (6")	(C51) WHITE DIAGONAL (12")
(V22) 10 FT WHITE SKIP (6")	(C79) MERGE ARROW
(V23) 3 FT-9 FT/SP WHITE MINISKIP (6")	
(V30) YELLOW EDGELINE (6")	
(V50) WHITE GORELINE (12")	
(V53) WHITE SOLID LANE LINE (12")	



\$\$\$\$\$SYTIME\$\$\$\$\$  
 \$\$\$\$DDGN\$\$\$\$\$  
 \$\$\$\$USERNAME\$\$\$\$\$

PAVEMENT MARKING DETAIL

TIP NO. R-2707D	SHEET NO. PMP-28
APPROVED: <i>Betsy L. Watson</i>	
DATE: 4/24/2023	
SEAL	
	
<p><b>DOCUMENT NOT CONSIDERED FINAL UNLESS ALL SIGNATURES COMPLETED</b></p>	
	

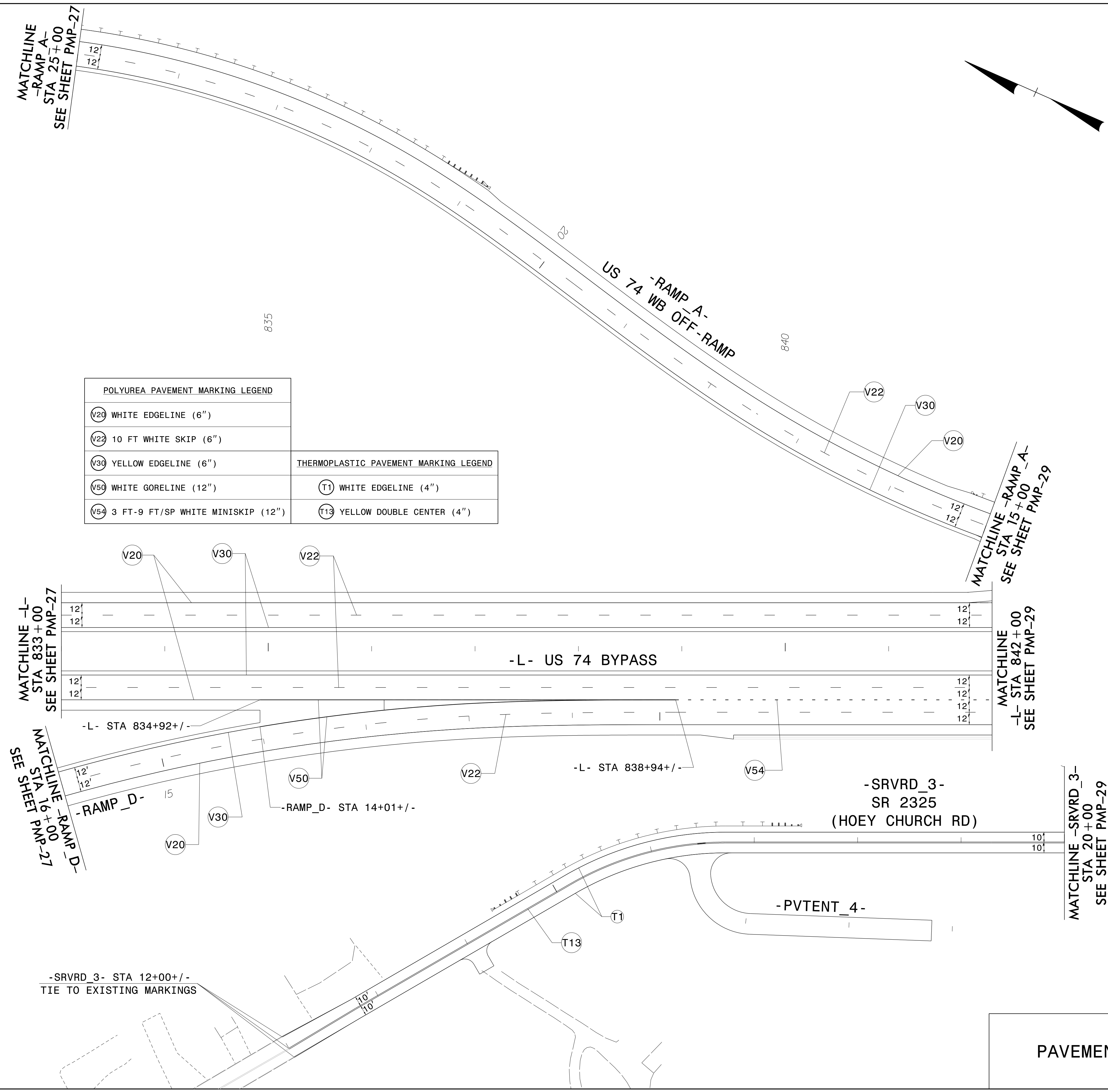



POLYUREA PAVEMENT MARKING LEGEND	
V20	WHITE EDGELINE (6")
V22	10 FT WHITE SKIP (6")
V30	YELLOW EDGELINE (6")
V50	WHITE GORELINE (12")
V54	3 FT-9 FT/SP WHITE MINISKIP (12")

THERMOPLASTIC PAVEMENT MARKING LEGEND	
T1	WHITE EDGELINE (4")
T13	YELLOW DOUBLE CENTER (4")

\$\$\$\$\$SYTIME\$\$\$\$\$  
 \$\$\$\$\$\$DGN\$\$\$\$\$  
 \$\$\$\$\$\$USERNAME\$\$\$\$\$

PAVEMENT MARKING DETAIL

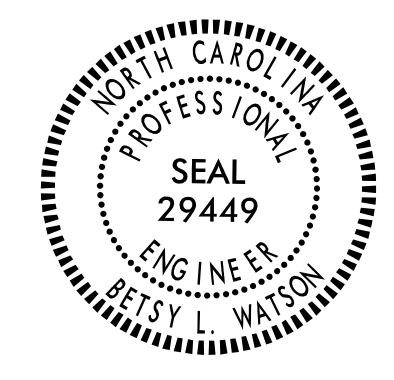

TIP NO. R-2707D	SHEET NO. PMP-29
APPROVED: <i>Betsy L. Watson</i>	
DATE: 4/24/2023	
SEAL	
	
DOCUMENT NOT CONSIDERED FINAL UNLESS ALL SIGNATURES COMPLETED	
	

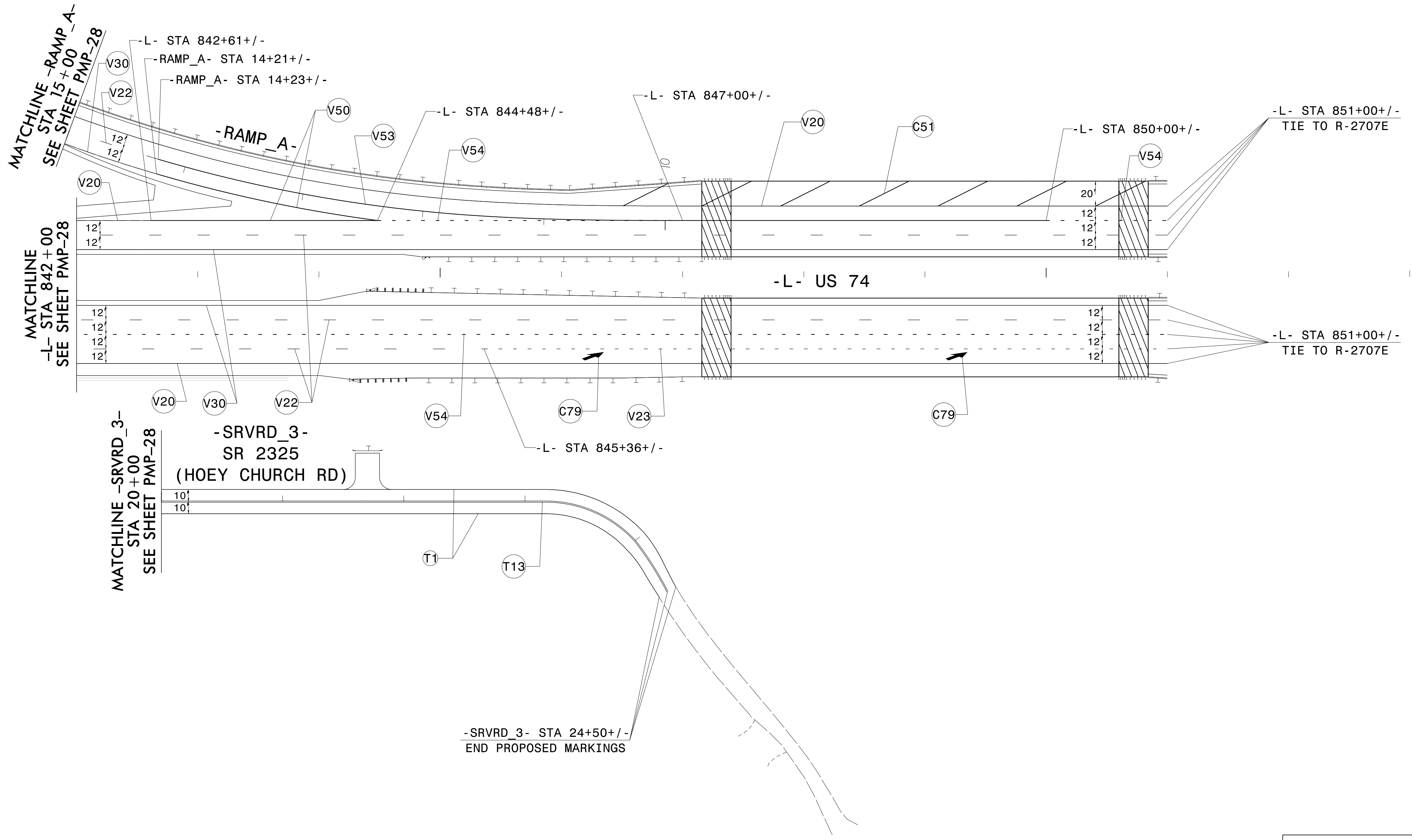
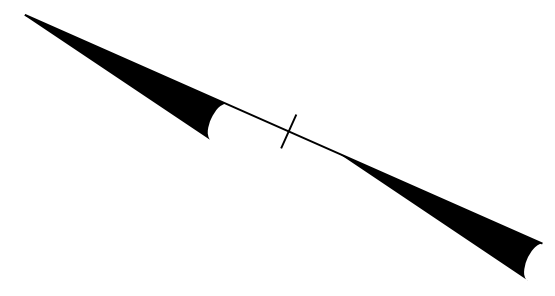

POLYUREA PAVEMENT MARKING LEGEND	COLD APPLIED PLASTIC PAVEMENT MARKING LEGEND	THERMOPLASTIC PAVEMENT MARKING LEGEND
(V20) WHITE EDGELINE (6")	(C51) WHITE DIAGONAL (12")	(T1) WHITE EDGELINE (4")
(V22) 10 FT WHITE SKIP (6")	(C79) MERGE ARROW	(T13) YELLOW DOUBLE CENTER (4")
(V23) 3 FT-9 FT/SP WHITE MINISKIP (6")		
(V30) YELLOW EDGELINE (6")		
(V50) WHITE GORELINE (12")		
(V53) WHITE SOLID LANE LINE (12")		
(V54) 3 FT-9 FT/SP WHITE MINISKIP (12")		







\$\$\$\$\$SYTIME\$\$\$\$\$  
 \$\$\$DDGN\$\$\$\$\$  
 \$\$\$USERNAME\$\$\$\$\$

PAVEMENT MARKING DETAIL

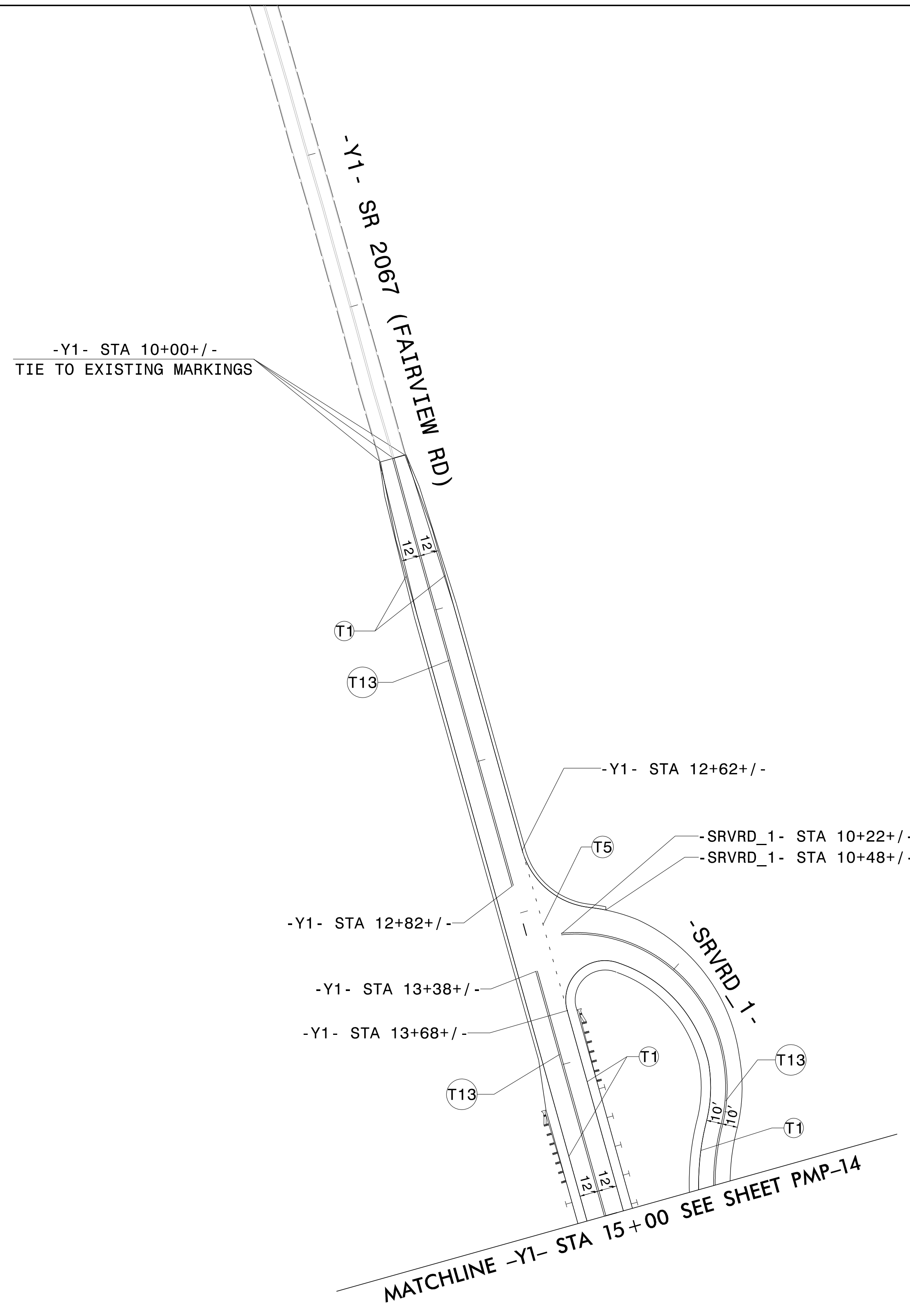
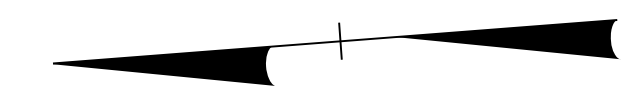

TIP NO. R-2707D	SHEET NO. PMP-30
APPROVED: <i>Betsy L. Watson</i>	
DATE: 4/24/2023	
SEAL	
	
DOCUMENT NOT CONSIDERED FINAL UNLESS ALL SIGNATURES COMPLETED	
	



THERMOPLASTIC PAVEMENT MARKING LEGEND	
	WHITE EDGELINE (4")
	2 FT-6 FT/SP WHITE MINISKIP (4")
	YELLOW DOUBLE CENTER (4")

PAVEMENT MARKING DETAIL

\$\$\$\$\$SYTIME\$\$\$\$\$  
\$\$\$\$\$DGN\$\$\$\$\$  
\$\$\$\$\$USERNAM\$\$\$\$\$

THERMOPLASTIC PAVEMENT MARKING LEGEND	
(T1)	WHITE EDGELINE (4")
(T5)	2 FT-6 FT/SP WHITE MINISKIP (4")
(T13)	YELLOW DOUBLE CENTER (4")
(T61)	WHITE STOPBAR (24")

TIP NO. R-2707D	SHEET NO. PMP-31
APPROVED: <i>Betsy L. Watson</i>	
DATE: 4/24/2023	
SEAL	
	
<b>DOCUMENT NOT CONSIDERED FINAL UNLESS ALL SIGNATURES COMPLETED</b>	

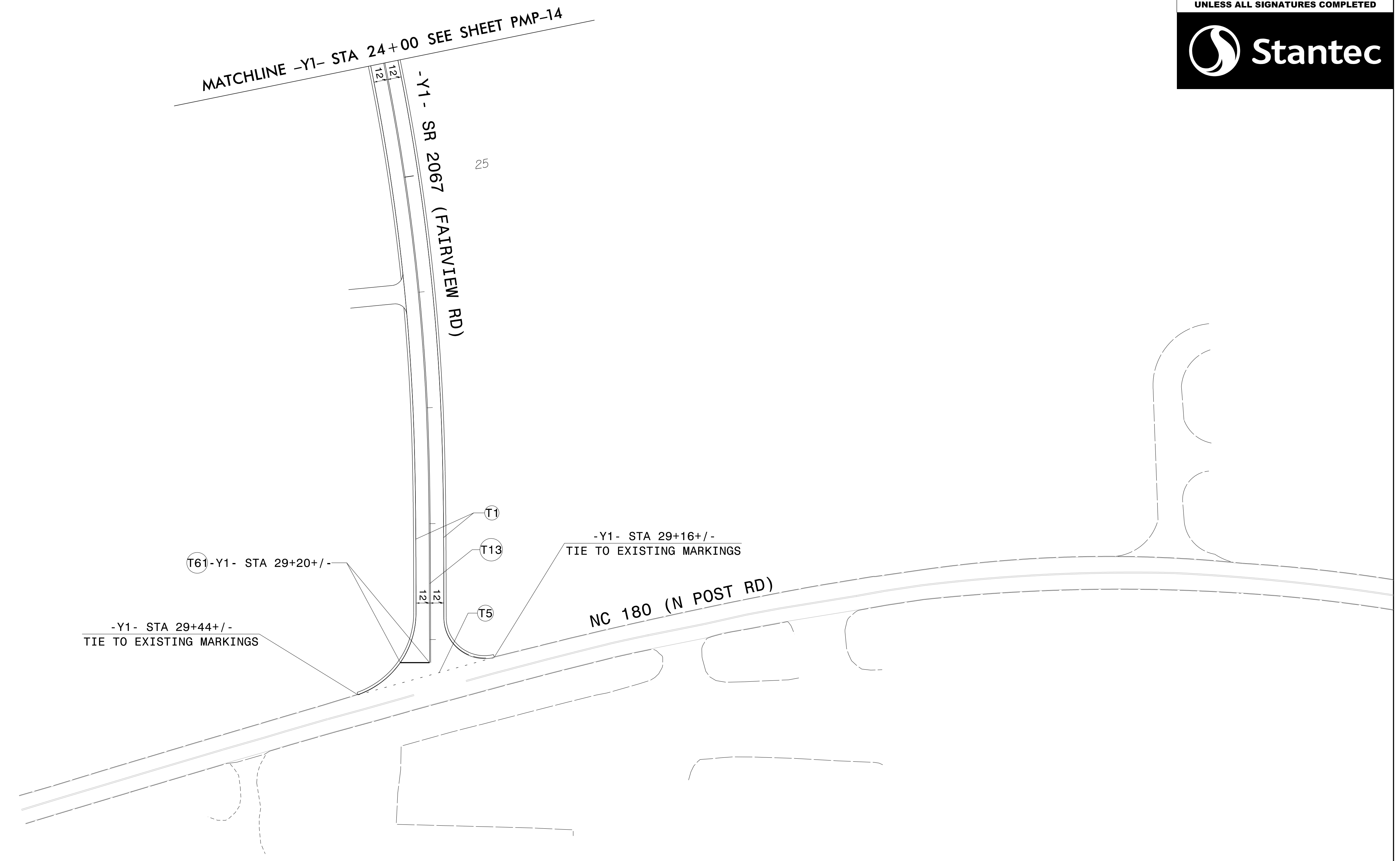
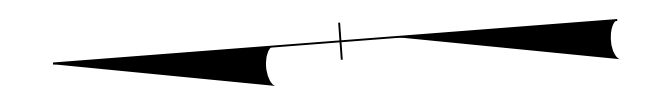

\$\$\$\$\$SYTIME\$\$\$\$\$  
 \$\$\$\$\$\$DGN\$\$\$\$\$  
 \$\$\$\$\$\$USERNAME\$\$\$\$\$

PAVEMENT MARKING DETAIL

THERMOPLASTIC PAVEMENT MARKING LEGEND	
(T1)	WHITE EDGELINE (4")
(T5)	2 FT-6 FT/SP WHITE MINISKIP (4")
(T13)	YELLOW DOUBLE CENTER (4")

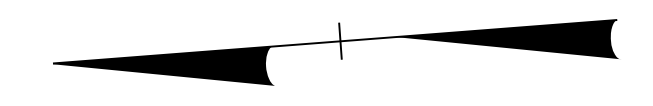

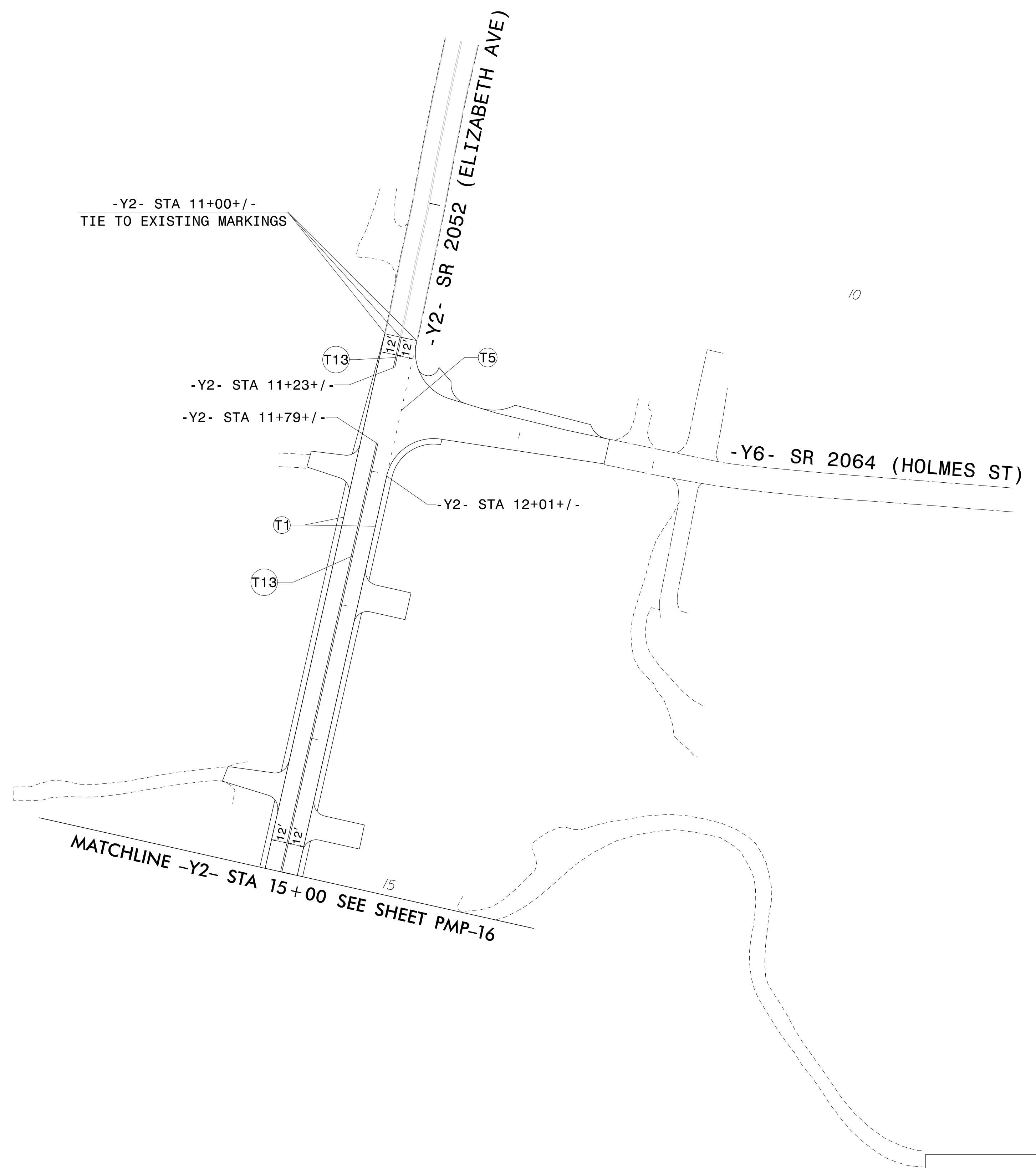

TIP NO. R-2707D	SHEET NO. PMP-32
APPROVED: <i>Petsy L. Watson</i>	
DATE: 4/24/2023	
SEAL	
<b>DOCUMENT NOT CONSIDERED FINAL UNLESS ALL SIGNATURES COMPLETED</b>	





\$\$\$\$\$SYTIME\$\$\$\$\$  
 \$\$\$\$\$\$DGN\$\$\$\$\$  
 \$\$\$\$\$\$USERNAME\$\$\$\$\$

PAVEMENT MARKING DETAIL



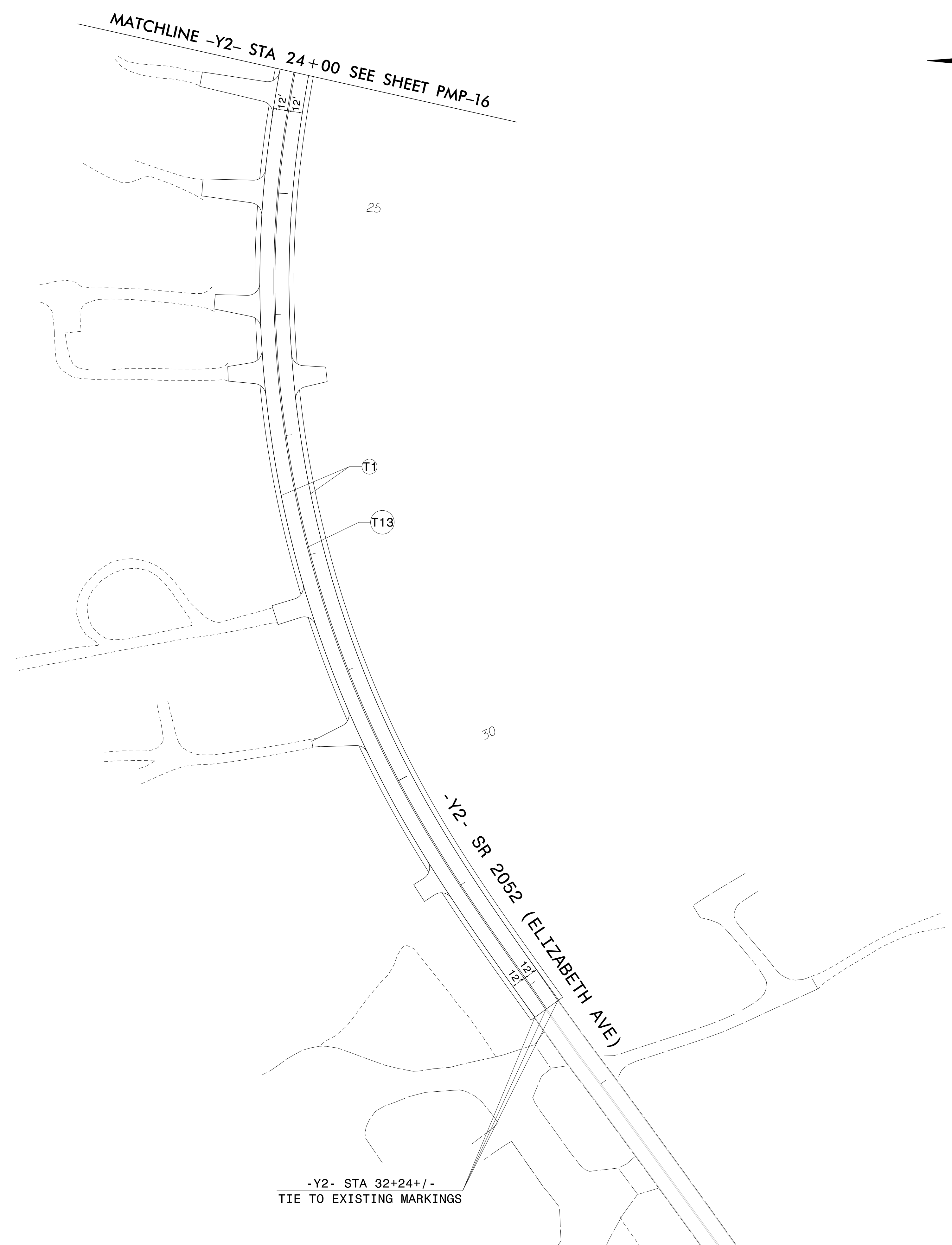
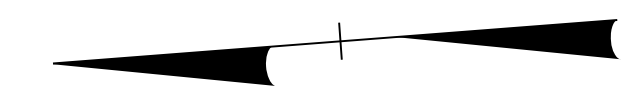

TIP NO. R-2707D	SHEET NO. PMP-33
APPROVED: <i>Betsy L. Watson</i>	
DATE: 4/24/2023	
SEAL	
	
DOCUMENT NOT CONSIDERED FINAL UNLESS ALL SIGNATURES COMPLETED	
	



THERMOPLASTIC PAVEMENT MARKING LEGEND	
	WHITE EDGELINE (4")
	YELLOW DOUBLE CENTER (4")

\$\$\$\$\$SYTIME\$\$\$\$\$  
 \$\$\$\$\$\$DGN\$\$\$\$\$  
 \$\$\$\$\$\$USERNAM\$\$\$\$\$

PAVEMENT MARKING DETAIL

TIP NO. R-2707D	SHEET NO. PMP-34
APPROVED: <i>Betsy L. Watson</i>	
DATE: 4/24/2023	
SEAL	
	
DOCUMENT NOT CONSIDERED FINAL UNLESS ALL SIGNATURES COMPLETED	
	

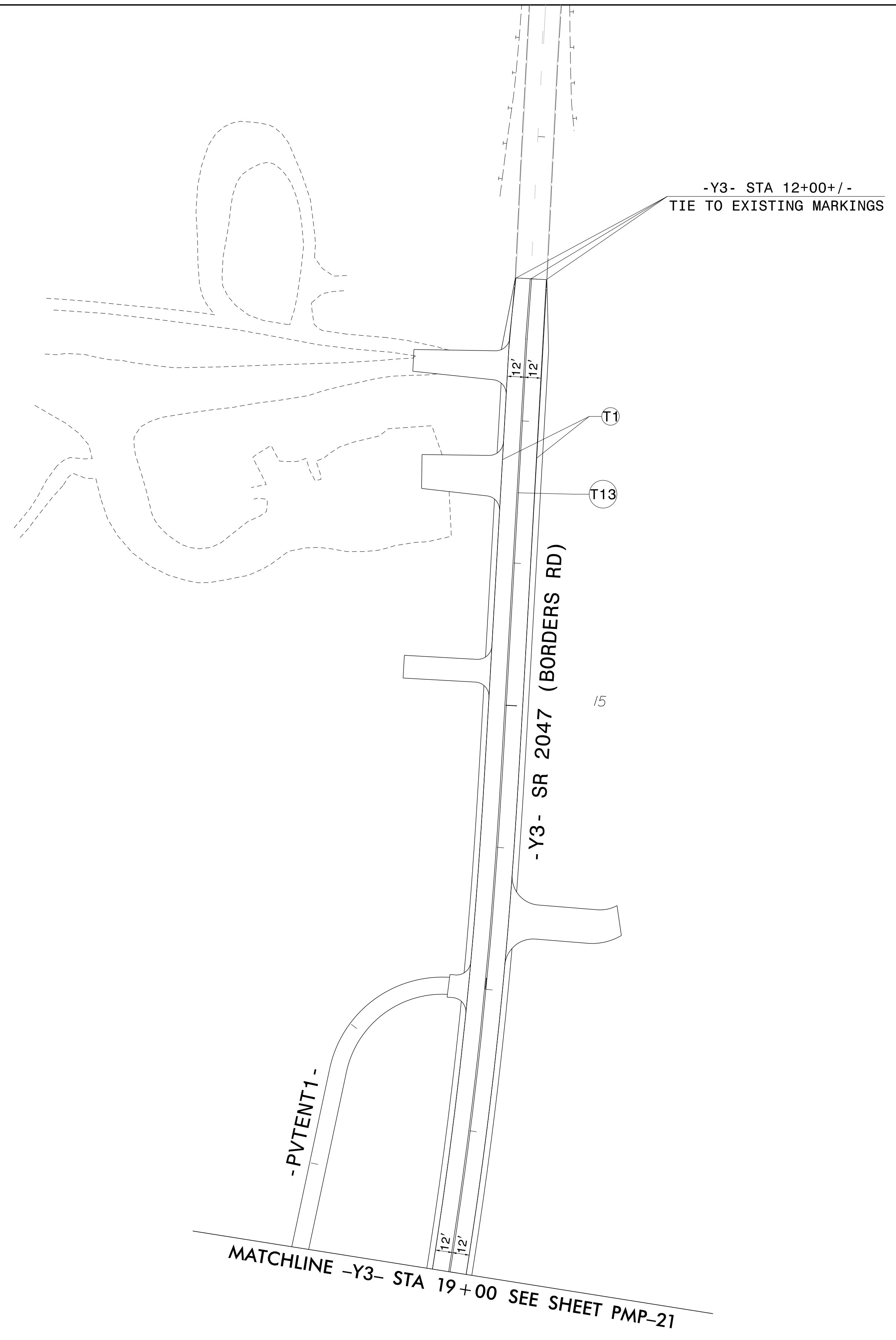
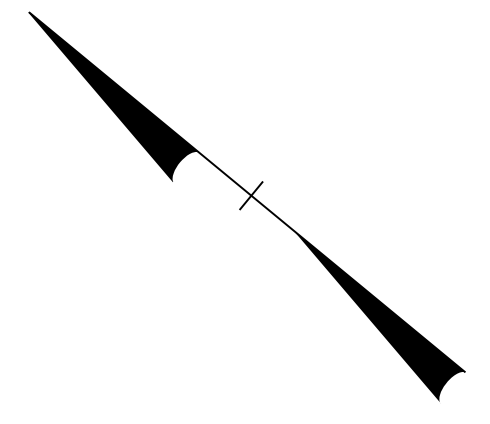

\$\$\$\$\$SYTIME\$\$\$\$\$  
 \$\$\$\$2\$\$\$\$\$  
 \$\$\$\$USERNAME\$\$\$\$\$

THERMOPLASTIC PAVEMENT MARKING LEGEND	
(T1)	WHITE EDGELINE (4")
(T13)	YELLOW DOUBLE CENTER (4")

PAVEMENT MARKING DETAIL

THERMOPLASTIC PAVEMENT MARKING LEGEND	
(T1)	WHITE EDGELINE (4")
(T5)	2 FT-6 FT/SP WHITE MINISKIP (4")
(T13)	YELLOW DOUBLE CENTER (4")

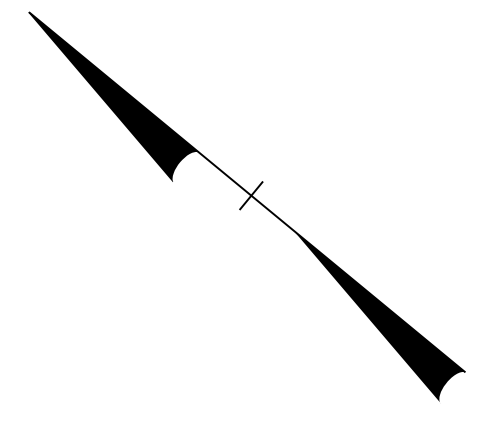

TIP NO. R-2707D	SHEET NO. PMP-35
APPROVED: <i>Betsy L. Watson</i>	
DATE: 4/24/2023	
SEAL	
DOCUMENT NOT CONSIDERED FINAL UNLESS ALL SIGNATURES COMPLETED	

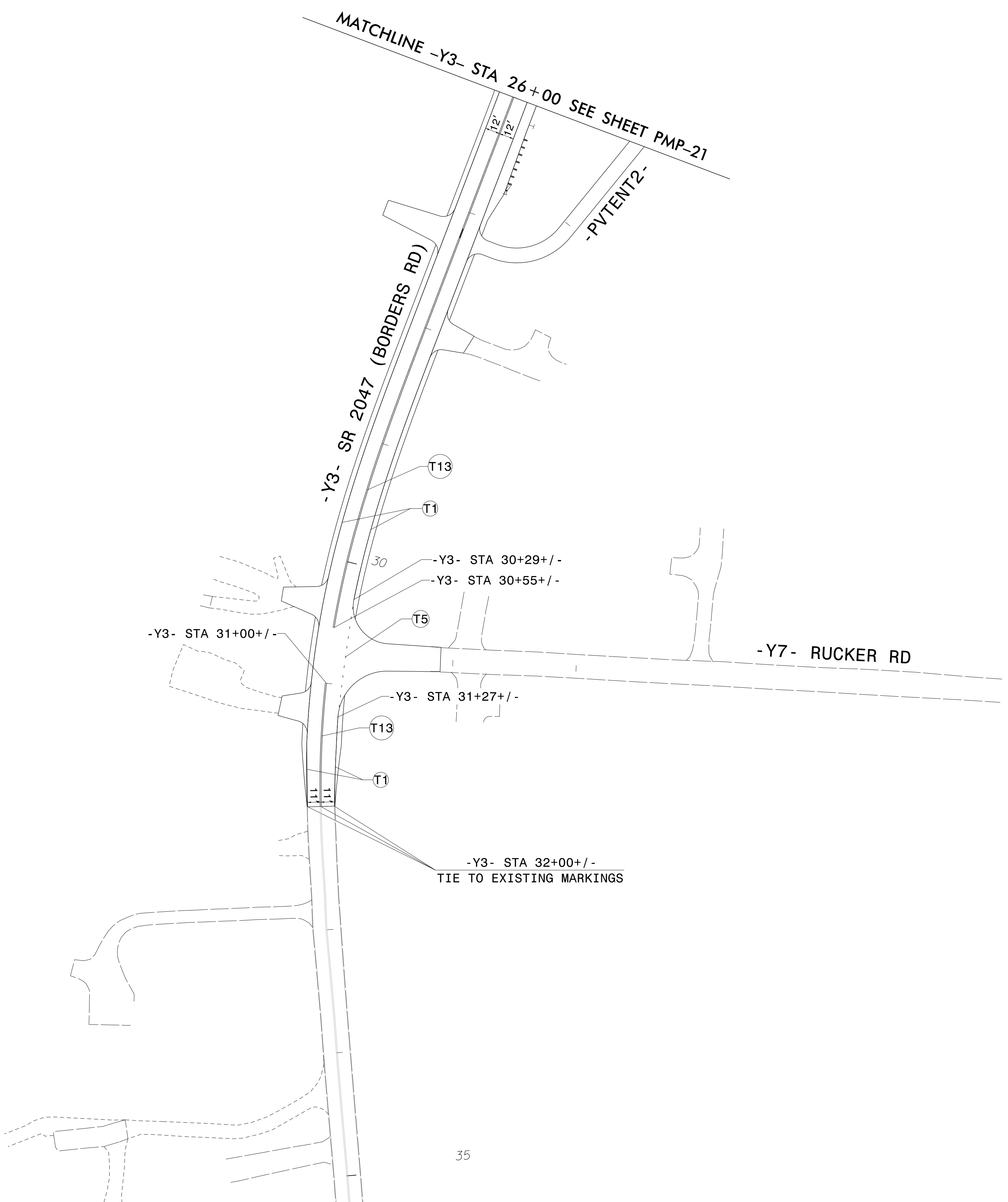

\$\$\$\$\$SYTIME\$\$\$\$\$  
 \$\$\$\$\$\$DGN\$\$\$\$\$  
 \$\$\$\$\$\$USERNAME\$\$\$\$\$

PAVEMENT MARKING DETAIL



TIP NO. R-2707D	SHEET NO. PMP-36
APPROVED: <i>Betsy L. Watson</i>	
DATE: 4/24/2023	
SEAL	
	
DOCUMENT NOT CONSIDERED FINAL UNLESS ALL SIGNATURES COMPLETED	



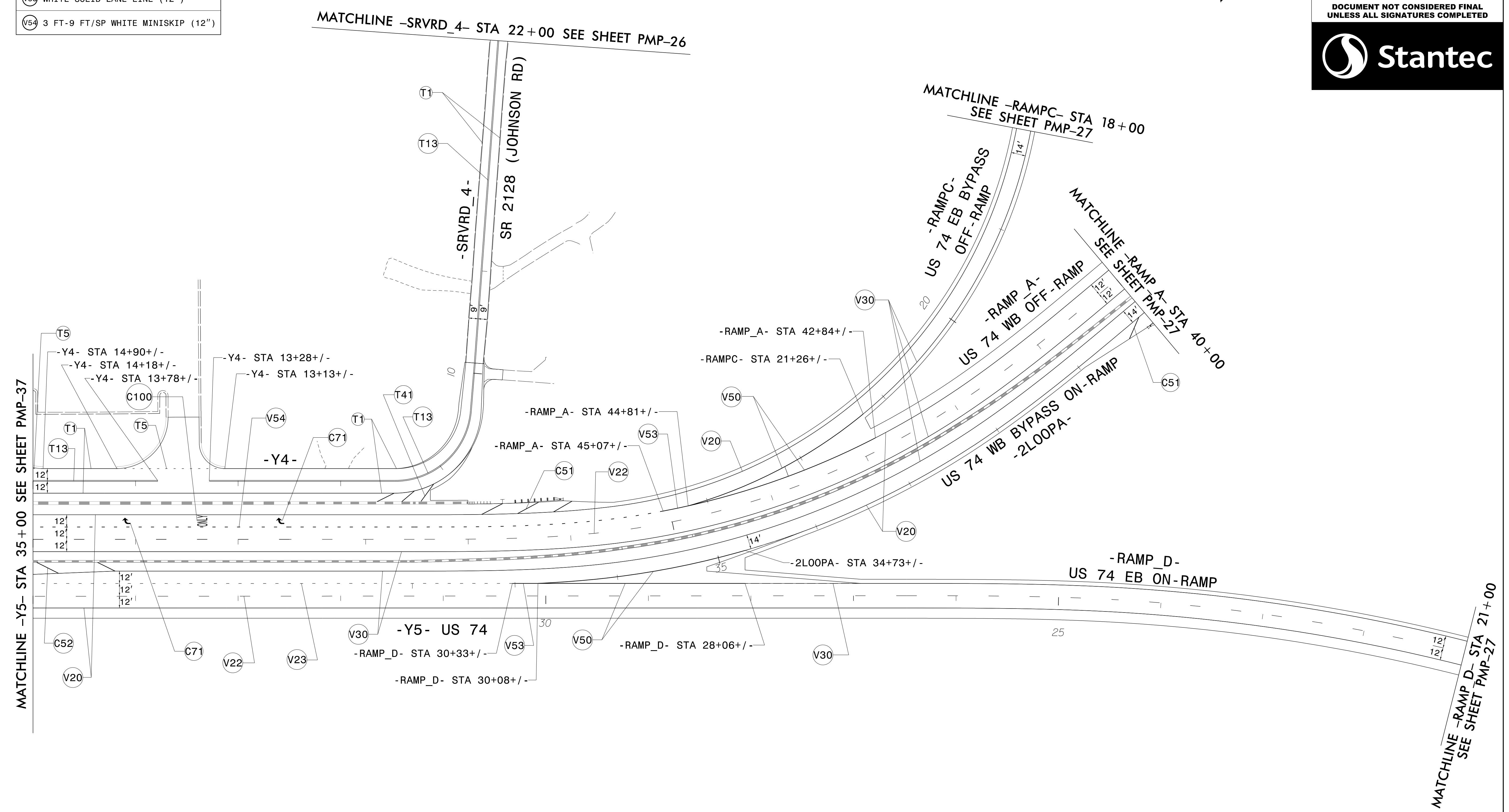
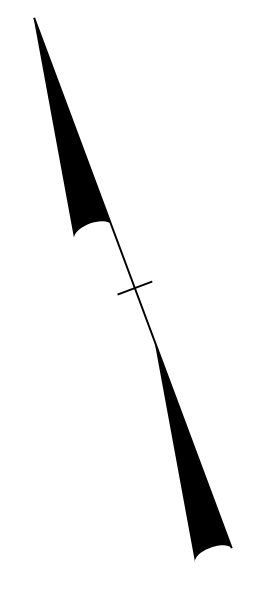

POLYUREA PAVEMENT MARKING LEGEND	COLD APPLIED PLASTIC PAVEMENT MARKING LEGEND	THERMOPLASTIC PAVEMENT MARKING LEGEND
V20 WHITE EDGELINE (6")	C51 WHITE DIAGONAL (12")	T1 WHITE EDGELINE (4")
V22 10 FT WHITE SKIP (6")	C52 YELLOW DIAGONAL (12")	T5 2 FT-6 FT/SP WHITE MINISKIP (4")
V23 3 FT-9 FT/SP WHITE MINISKIP (6")	C71 RIGHT TURN ARROW	T13 YELLOW DOUBLE CENTER (4")
V30 YELLOW EDGELINE (6")	C100 ONLY ALPHANUMERIC CHARACTERS	T41 WHITE DIAGONAL (8")
V50 WHITE GORELINE (12")		
V53 WHITE SOLID LANE LINE (12")		
V54 3 FT-9 FT/SP WHITE MINISKIP (12")		

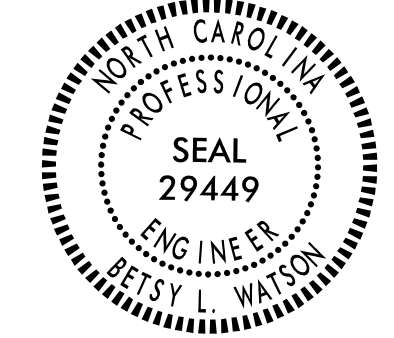

\$\$\$\$\$SYSTEMTIME\$\$\$\$\$  
 \$\$\$\$\$\$DGN\$\$\$\$\$  
 \$\$\$\$\$\$USERNAME\$\$\$\$\$

PAVEMENT MARKING DETAIL

TIP NO. R-2707D	SHEET NO. PMP-37
APPROVED: <i>Petsy L. Watson</i>	
DATE: 4/24/2023	
SEAL	
	
<p><b>DOCUMENT NOT CONSIDERED FINAL UNLESS ALL SIGNATURES COMPLETED</b></p>	
	

POLYUREA PAVEMENT MARKING LEGEND	COLD APPLIED PLASTIC PAVEMENT MARKING LEGEND	THERMOPLASTIC PAVEMENT MARKING LEGEND
(V20) WHITE EDGELINE (6")	(C51) WHITE DIAGONAL (12")	(T1) WHITE EDGELINE (4")
(V22) 10 FT WHITE SKIP (6")	(C52) YELLOW DIAGONAL (12")	(T5) 2 FT-6 FT/SP WHITE MINISKIP (4")
(V23) 3 FT-9 FT/SP WHITE MINISKIP (6")	(C71) RIGHT TURN ARROW	(T13) YELLOW DOUBLE CENTER (4")
(V24) 2 FT-6 FT/SP WHITE MINISKIP (6")	(C100) ONLY ALPHANUMERIC CHARACTERS	(T4) WHITE DIAGONAL (8")
(V30) YELLOW EDGELINE (6")		(T6) WHITE STOPBAR (24")
(V34) 2 FT-6 FT/SP YELLOW MINISKIP (6")		(T71) RIGHT TURN ARROW
(V40) WHITE GORELINE (8")		
(V53) WHITE SOLID LANE LINE (12")		
(V54) 3 FT-9 FT/SP WHITE MINISKIP (12")		

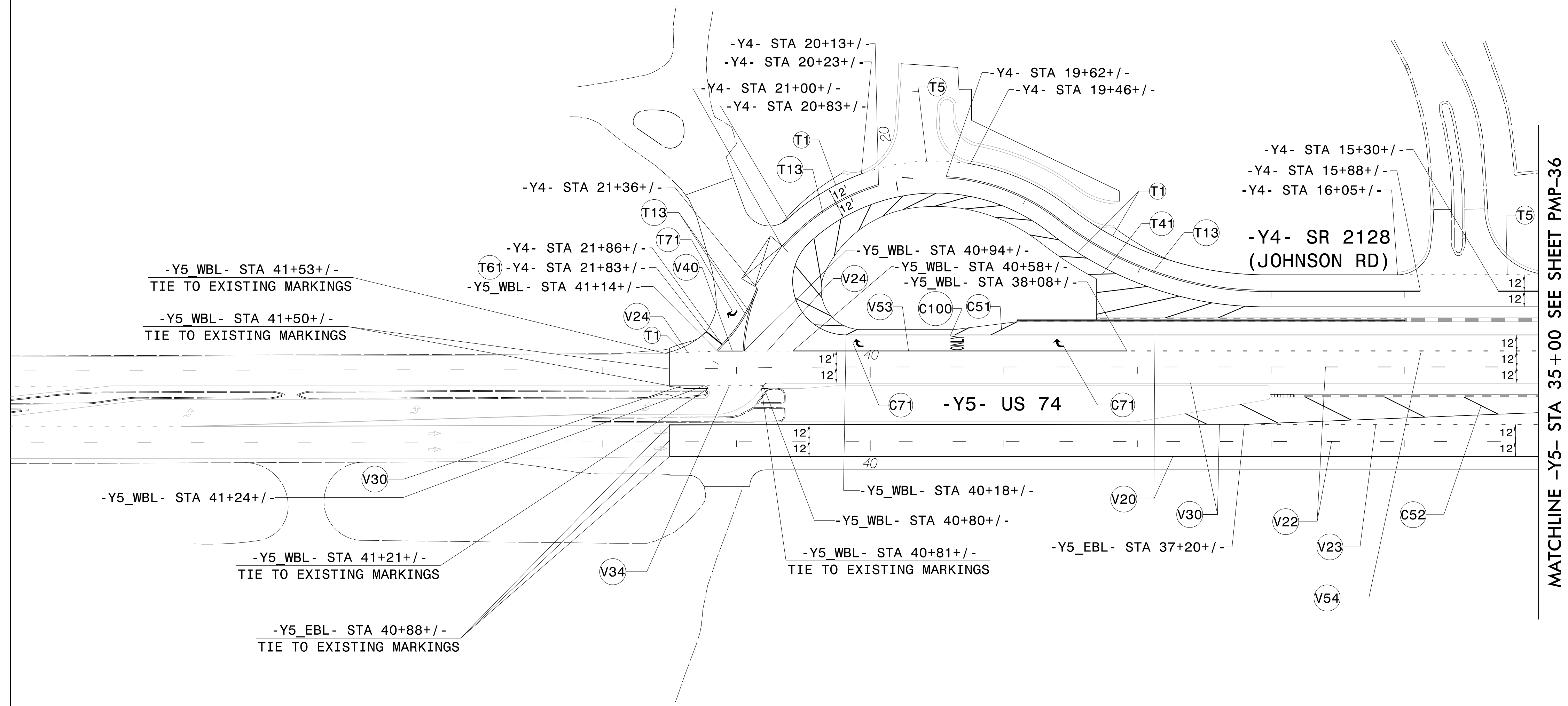
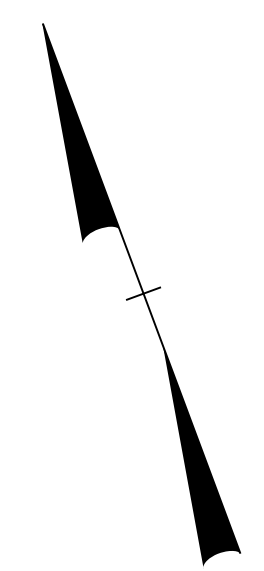

MATCHLINE -Y5- STA 35+00 SEE SHEET PMP-36

PAVEMENT MARKING DETAIL

\$\$\$\$\$SYTIME\$\$\$\$\$  
 \$\$\$\$\$\$DGN\$\$\$\$\$  
 \$\$\$\$\$\$USERNAME\$\$\$\$\$