

09_08/2019

See Sheet 1A For Index of Sheets, See Sheet 1B For Conventional Symbols

STATE OF NORTH CAROLINA
DIVISION OF HIGHWAYS

CUMBERLAND COUNTY

LOCATION: NC-24, BRAGG BOULEVARD FROM US-401 (SKIBO ROAD) TO STAMPER RD.

TYPE OF WORK: MEDIAN AND GUARDRAIL REPLACEMENT, ADD PEDESTRIAN SIGNALS, DRAINAGE, GRADING, PAVING

STATE	STATE PROJECT REFERENCE NO.	SHEET NO.	TOTAL SHEETS
N.C.	U-6229	1	
STATE PROJ. NO.	F.A. PROJ. NO.	DESCRIPTION	
48808.1.1		PE	
48808.2.1		RW, UTIL	
48808.3.1	0024098	CONST.	

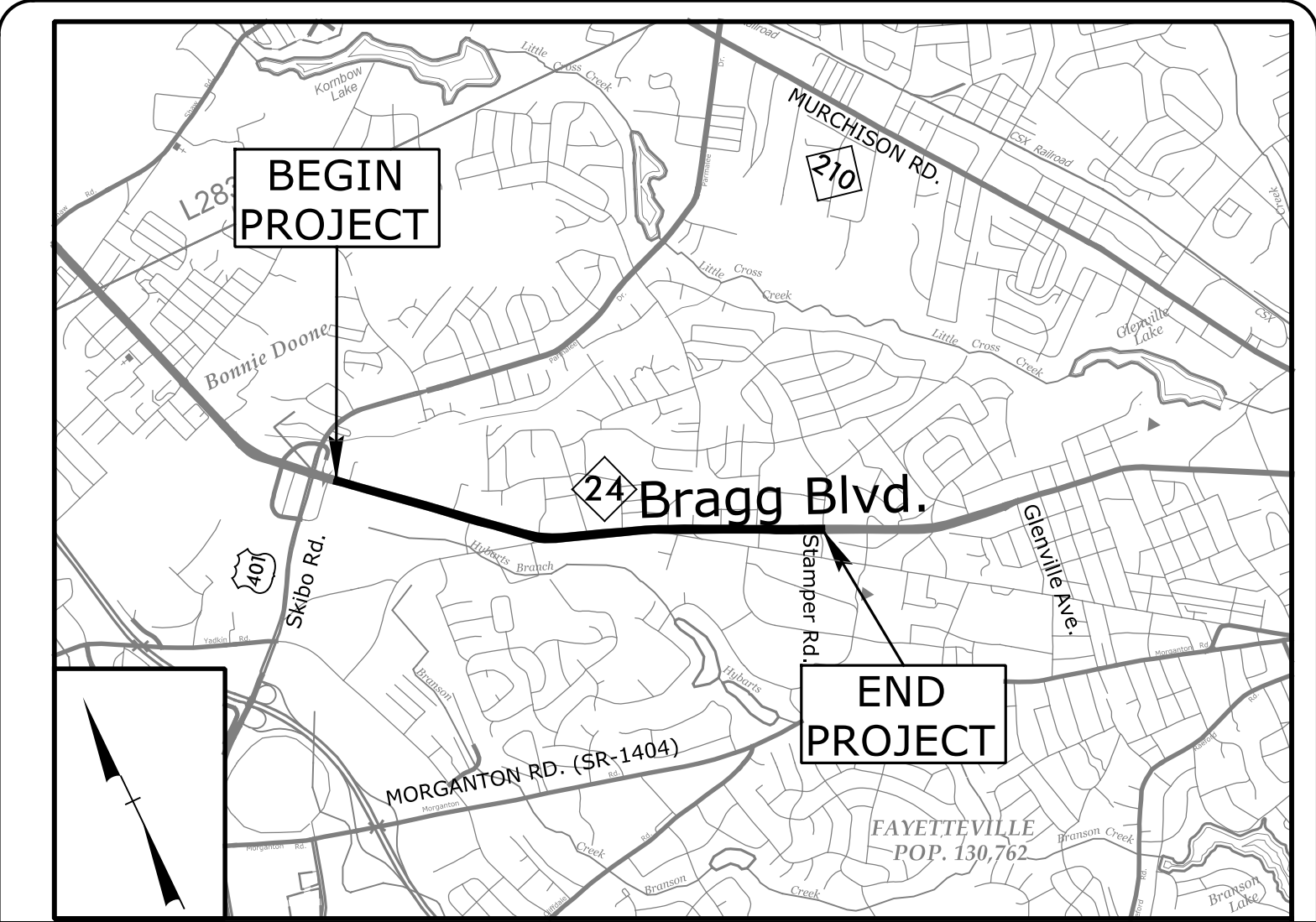
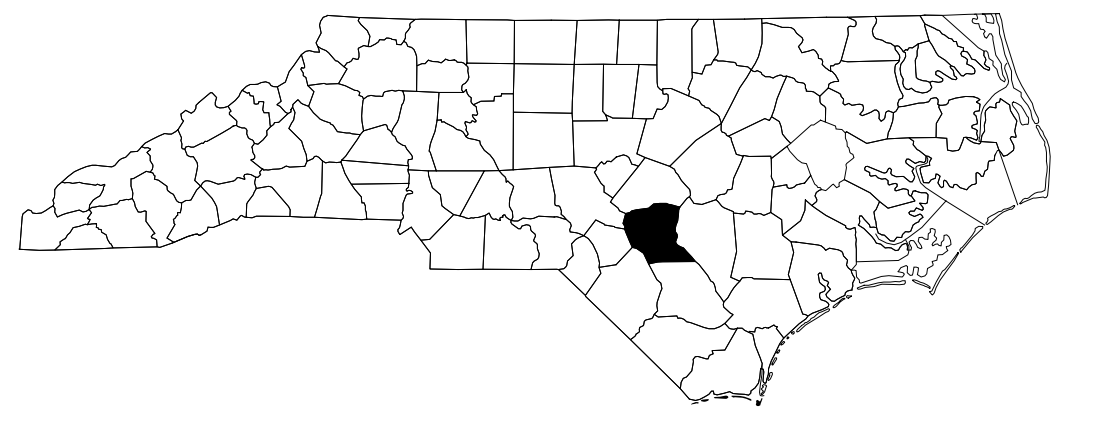

VICINITY MAP
NOT TO SCALE

TIP PROJECT: U-6229

CONTRACT: C204891

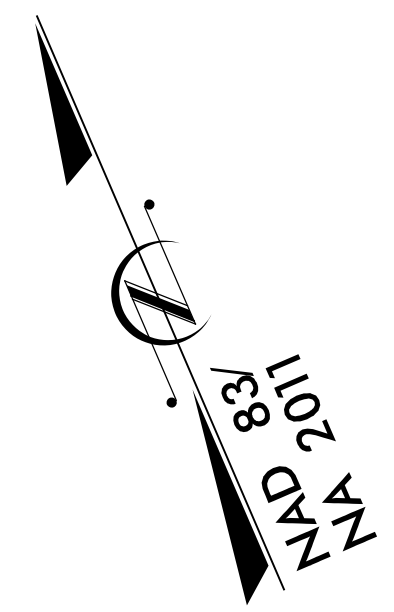
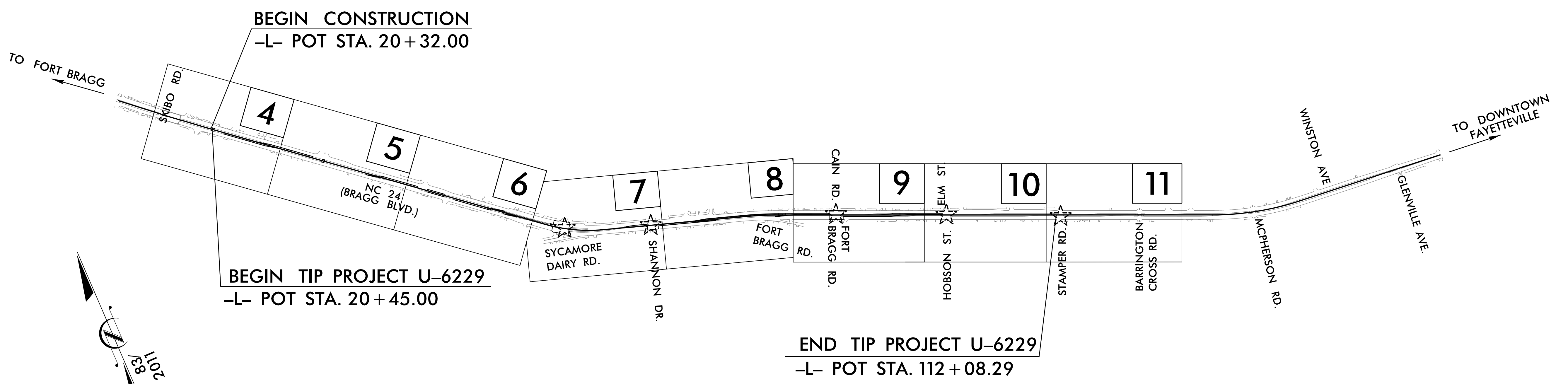

☆ EXISTING SIGNALS TO BE MODIFIED

DOCUMENT NOT CONSIDERED FINAL
UNLESS ALL SIGNATURES COMPLETED

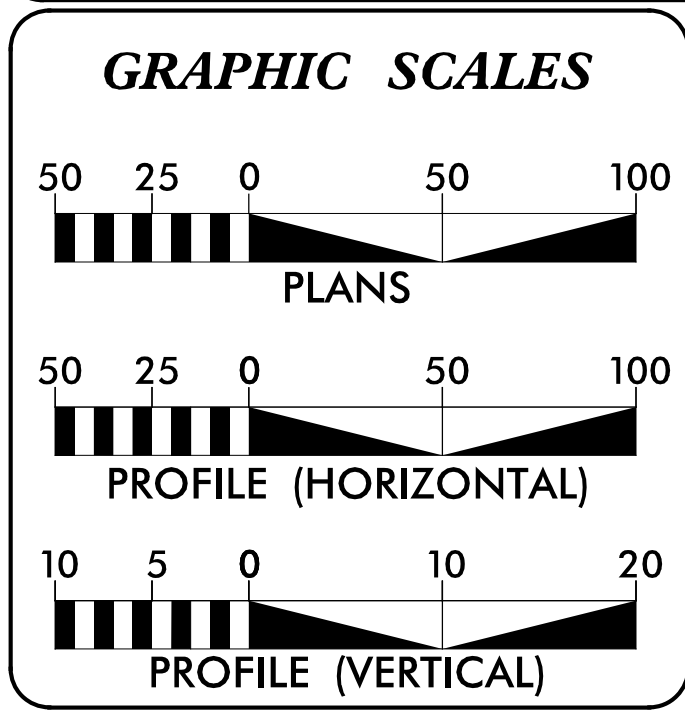

DESIGN DATA

ADT 2022 =	34,460
ADT 2045 =	43,200
K =	9 %
D =	53 %
T =	5 % *
V =	50 MPH
* TTST = 2% DUAL 3%	
FUNC CLASS =	
PRINCIPAL ARTERIAL	
STATEWIDE TIER	

PROJECT LENGTH

LENGTH ROADWAY TIP PROJECT U-6229	=	1.735 MILES
TOTAL LENGTH OF TIP PROJECT U-6229	=	1.735 MILES

Prepared for the North Carolina Department of Transportation in the office of:

Venture I
940 Main Campus Drive, Suite 500
Raleigh, NC 27606
NC License No. C-3705

2018 STANDARD SPECIFICATIONS	JERRY JAVELLANA, PE PROJECT ENGINEER
RIGHT OF WAY DATE: N/A	RYAN SARGENT, PE PROJECT DESIGN ENGINEER
LETTING DATE: JUNE 20, 2023	JOHN B. GAUTHIER DIVISION PROJECT ENGINEER
NCDOT CONTACT:	

HYDRAULICS ENGINEER

DocuSigned by: 3/28/2023
Brandon Barlow
421317099DCA48F
SIGNATURE: P.E.

ROADWAY DESIGN ENGINEER

DocuSigned by: Jerry Javellana/28/2023
4152564889F439
SIGNATURE: P.E.

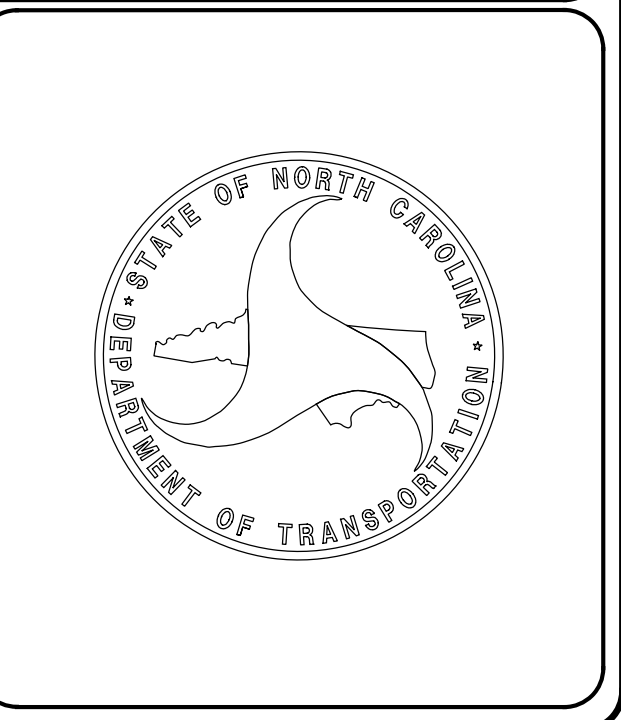

STATE OF NORTH CAROLINA, DIVISION OF HIGHWAYS
CONVENTIONAL PLAN SHEET SYMBOLS

Note: Not to Scale

BOUNDARIES AND PROPERTY:

Table listing boundary types such as State Line, County Line, Township Line, City Line, Reservation Line, Property Line, Existing Iron Pin (EIP), Computed Property Corner, Existing Concrete Monument (ECM), Parcel/Sequence Number, Existing Fence Line, Proposed Woven Wire Fence, Proposed Chain Link Fence, Proposed Barbed Wire Fence, Existing Wetland Boundary, Proposed Wetland Boundary, Existing Endangered Animal Boundary, Existing Endangered Plant Boundary, Existing Historic Property Boundary, Known Contamination Area: Soil, Potential Contamination Area: Soil, Known Contamination Area: Water, Potential Contamination Area: Water, Contaminated Site: Known or Potential.

BUILDINGS AND OTHER CULTURE:

Table listing building and cultural symbols such as Gas Pump Vent or U/G Tank Cap, Sign, Well, Small Mine, Foundation, Area Outline, Cemetery, Building, School, Church, Dam.

HYDROLOGY:

Table listing hydrology symbols such as Stream or Body of Water, Hydro, Pool or Reservoir, Jurisdictional Stream, Buffer Zone 1, Buffer Zone 2, Flow Arrow, Disappearing Stream, Spring, Wetland, Proposed Lateral, Tail, Head Ditch, False Sump.

RAILROADS:

Table listing railroad symbols such as Standard Gauge, RR Signal Milepost, Switch, RR Abandoned, RR Dismantled.

RIGHT OF WAY & PROJECT CONTROL:

Table listing right of way and project control symbols such as Primary Horiz Control Point, Primary Horiz and Vert Control Point, Secondary Horiz and Vert Control Point, Vertical Benchmark, Existing Right of Way Monument, Proposed Right of Way Monument (Rebar and Cap), Proposed Right of Way Monument (Concrete), Existing Permanent Easement Monument, Proposed Permanent Easement Monument (Rebar and Cap), Existing C/A Monument, Proposed C/A Monument (Rebar and Cap), Proposed C/A Monument (Concrete), Existing Right of Way Line, Proposed Right of Way Line, Existing Control of Access Line, Proposed Control of Access Line, Proposed ROW and CA Line, Existing Easement Line, Proposed Temporary Construction Easement, Proposed Temporary Drainage Easement, Proposed Permanent Drainage Easement, Proposed Permanent Drainage/Utility Easement, Proposed Permanent Utility Easement, Proposed Temporary Utility Easement, Proposed Aerial Utility Easement.

ROADS AND RELATED FEATURES:

Table listing road and related features symbols such as Existing Edge of Pavement, Existing Curb, Proposed Slope Stakes Cut, Proposed Slope Stakes Fill, Proposed Curb Ramp, Existing Metal Guardrail, Proposed Guardrail, Existing Cable Guiderail, Proposed Cable Guiderail, Equality Symbol, Pavement Removal, VEGETATION: Single Tree, Single Shrub, Hedge.

Table listing symbols for Woods Line, Orchard, Vineyard.

EXISTING STRUCTURES:

Table listing existing structures symbols such as Bridge, Tunnel or Box Culvert, Bridge Wing Wall, Head Wall and End Wall, Head and End Wall, Pipe Culvert, Footbridge, Drainage Box: Catch Basin, DI or JB, Paved Ditch Gutter, Storm Sewer Manhole, Storm Sewer.

UTILITIES:

* SUE - Subsurface Utility Engineering
LOS - Level of Service - A, B, C or D (Accuracy)

POWER:

Table listing power symbols such as Existing Power Pole, Proposed Power Pole, Existing Joint Use Pole, Proposed Joint Use Pole, Power Manhole, Power Line Tower, Power Transformer, U/G Power Cable Hand Hole, H-Frame Pole, U/G Power Line Test Hole (SUE - LOS A)*, U/G Power Line (SUE - LOS B)*, U/G Power Line (SUE - LOS C)*, U/G Power Line (SUE - LOS D)*.

TELEPHONE:

Table listing telephone symbols such as Existing Telephone Pole, Proposed Telephone Pole, Telephone Manhole, Telephone Pedestal, Telephone Cell Tower, U/G Telephone Cable Hand Hole, U/G Telephone Test Hole (SUE - LOS A)*, U/G Telephone Cable (SUE - LOS B)*, U/G Telephone Cable (SUE - LOS C)*, U/G Telephone Cable (SUE - LOS D)*, U/G Telephone Conduit (SUE - LOS B)*, U/G Telephone Conduit (SUE - LOS C)*, U/G Telephone Conduit (SUE - LOS D)*, U/G Fiber Optics Cable (SUE - LOS B)*, U/G Fiber Optics Cable (SUE - LOS C)*, U/G Fiber Optics Cable (SUE - LOS D)*.

WATER:

Table listing water symbols such as Water Manhole, Water Meter, Water Valve, Water Hydrant, U/G Water Line Test Hole (SUE - LOS A)*, U/G Water Line (SUE - LOS B)*, U/G Water Line (SUE - LOS C)*, U/G Water Line (SUE - LOS D)*, Above Ground Water Line.

TV:

Table listing TV symbols such as TV Pedestal, TV Tower, U/G TV Cable Hand Hole, U/G TV Test Hole (SUE - LOS A)*, U/G TV Cable (SUE - LOS B)*, U/G TV Cable (SUE - LOS C)*, U/G TV Cable (SUE - LOS D)*, U/G Fiber Optic Cable (SUE - LOS B)*, U/G Fiber Optic Cable (SUE - LOS C)*, U/G Fiber Optic Cable (SUE - LOS D)*.

GAS:

Table listing gas symbols such as Gas Valve, Gas Meter, U/G Gas Line Test Hole (SUE - LOS A)*, U/G Gas Line (SUE - LOS B)*, U/G Gas Line (SUE - LOS C)*, U/G Gas Line (SUE - LOS D)*, Above Ground Gas Line.

SANITARY SEWER:

Table listing sanitary sewer symbols such as Sanitary Sewer Manhole, Sanitary Sewer Cleanout, U/G Sanitary Sewer Line, Above Ground Sanitary Sewer, SS Force Main Line Test Hole (SUE - LOS A)*, SS Force Main Line (SUE - LOS B)*, SS Force Main Line (SUE - LOS C)*, SS Force Main Line (SUE - LOS D)*.

MISCELLANEOUS:

Table listing miscellaneous symbols such as Utility Pole, Utility Pole with Base, Utility Located Object, Utility Traffic Signal Box, Utility Unknown U/G Line (SUE - LOS B)*, U/G Tank; Water, Gas, Oil, Underground Storage Tank, Approx. Loc., A/G Tank; Water, Gas, Oil, Geoenvironmental Boring, Abandoned According to Utility Records, End of Information.

6/2/2023

FINAL PAVEMENT SCHEDULE

C1	PROP. APPROX. 1 1/2" ASPHALT CONCRETE SURFACE COURSE, TYPE S9.5C, AT AN AVERAGE RATE OF 168 LBS. PER SQ. YD.
C2	PROP. APPROX. 3" ASPHALT CONCRETE SURFACE COURSE, TYPE S9.5C, AT AN AVERAGE RATE OF 168 LBS. PER SQ. YD. IN EACH OF TWO LAYERS
D1	PROP. APPROX. 4" ASPHALT CONCRETE INTERMEDIATE COURSE, TYPE I19.0C, AT AN AVERAGE RATE OF 456 LBS. PER SQ. YD.
E1	PROP. APPROX. 4" ASPHALT CONCRETE BASE COURSE, TYPE B25.0C, AT AN AVERAGE RATE OF 456 LBS. PER SQ. YD.
R1	1'-6" CURB AND GUTTER
R2	2'-9" CURB AND GUTTER
R3	5" MONOLITHIC CONCRETE ISLAND (KEYED IN)
R4	4" CONCRETE COVER
T	EARTH MATERIAL
U	EXISTING PAVEMENT
V	MILLING ASPHALT PAVEMENT 1.5"

NOTE: PAVEMENT EDGE SLOPES ARE 1:1 UNLESS SHOWN OTHERWISE.
 NOTE: SEE PLANS FOR TURN LANE LOCATIONS

Prepared by



Venture I
940 Main Campus Drive, Suite 500
Raleigh, NC 27606
NC License No. C-9705

PROJECT REFERENCE NO. U-6229	SHEET NO. 2A-1
ROADWAY DESIGN ENGINEER JENNIFER J. JAVELLANA 039831	PAVEMENT DESIGN ENGINEER D. KENDALL 033796
5/12/2023	5/12/2023

DOCUMENT NOT CONSIDERED FINAL UNLESS ALL SIGNATURES COMPLETED

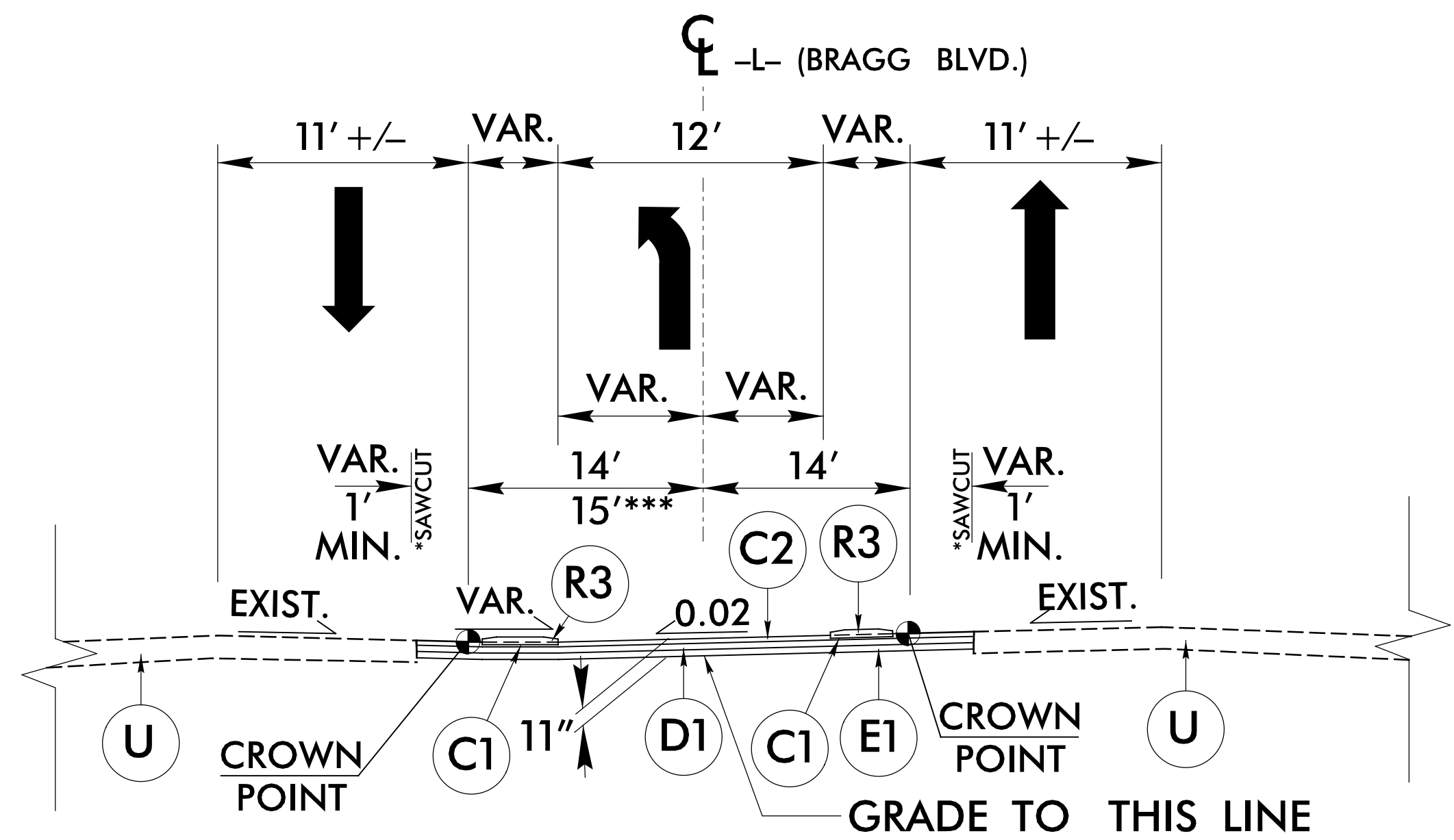

TYPICAL SECTION NO.1

- L- STA. 20+45.00 TO STA. 21+75.00 (MIRROR)
- *** -L- STA. 31+58.00 TO STA. 32+65.00 (MIRROR)
- *** -L- STA. 43+23.00 TO STA. 44+30.00
- L- STA. 46+25.00 TO STA. 47+32.00 (MIRROR)

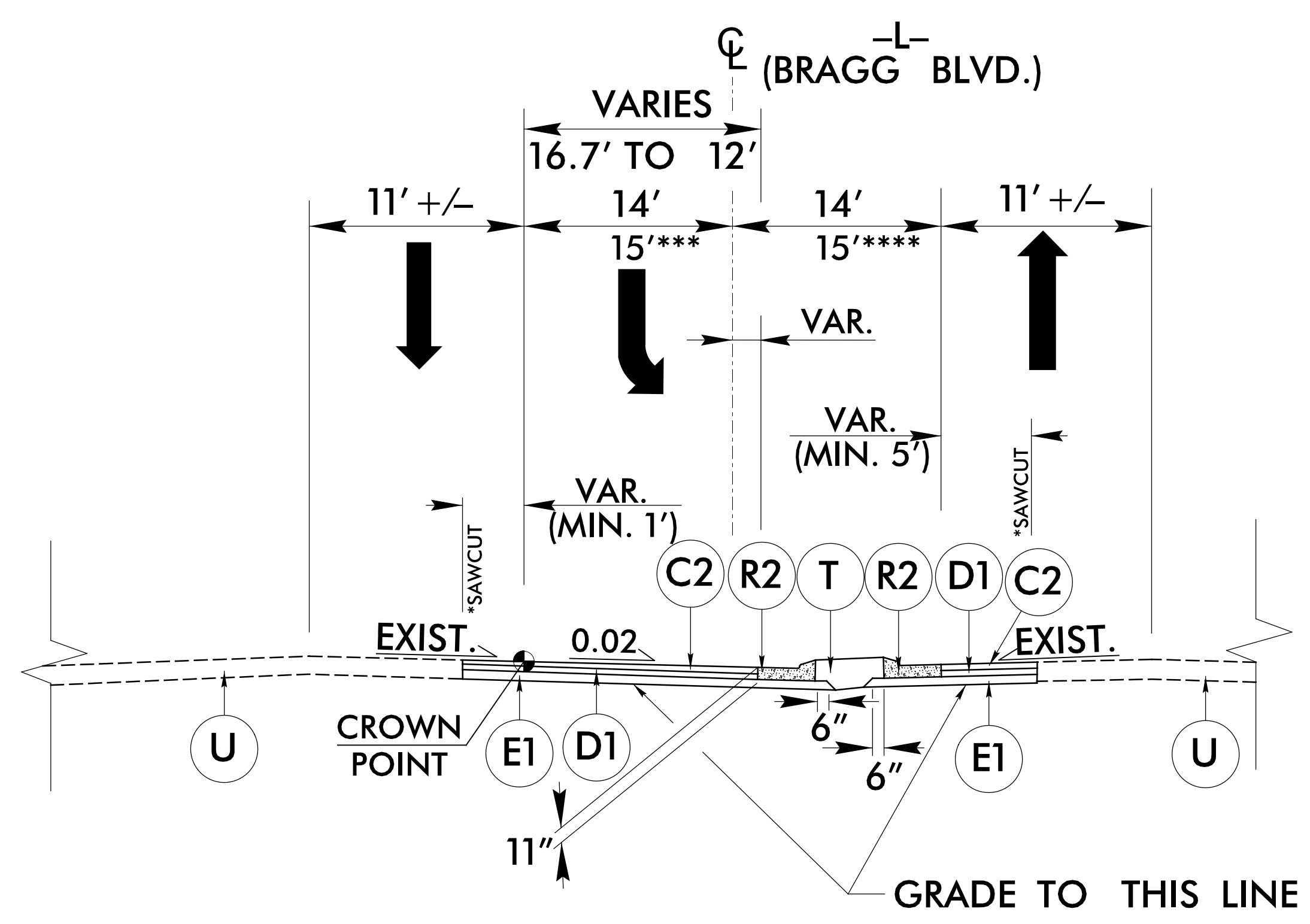

TYPICAL SECTION NO. 2

- L- STA. 21+75.00 TO STA. 26+35.00
- **** -L- STA. 28+00.00 TO STA. 31+58.00 (MIRROR)
- *** -L- STA. 39+50.00 TO STA. 43+23.00 (MIRROR)
- **** -L- STA. 47+32.00 TO STA. 51+05.00

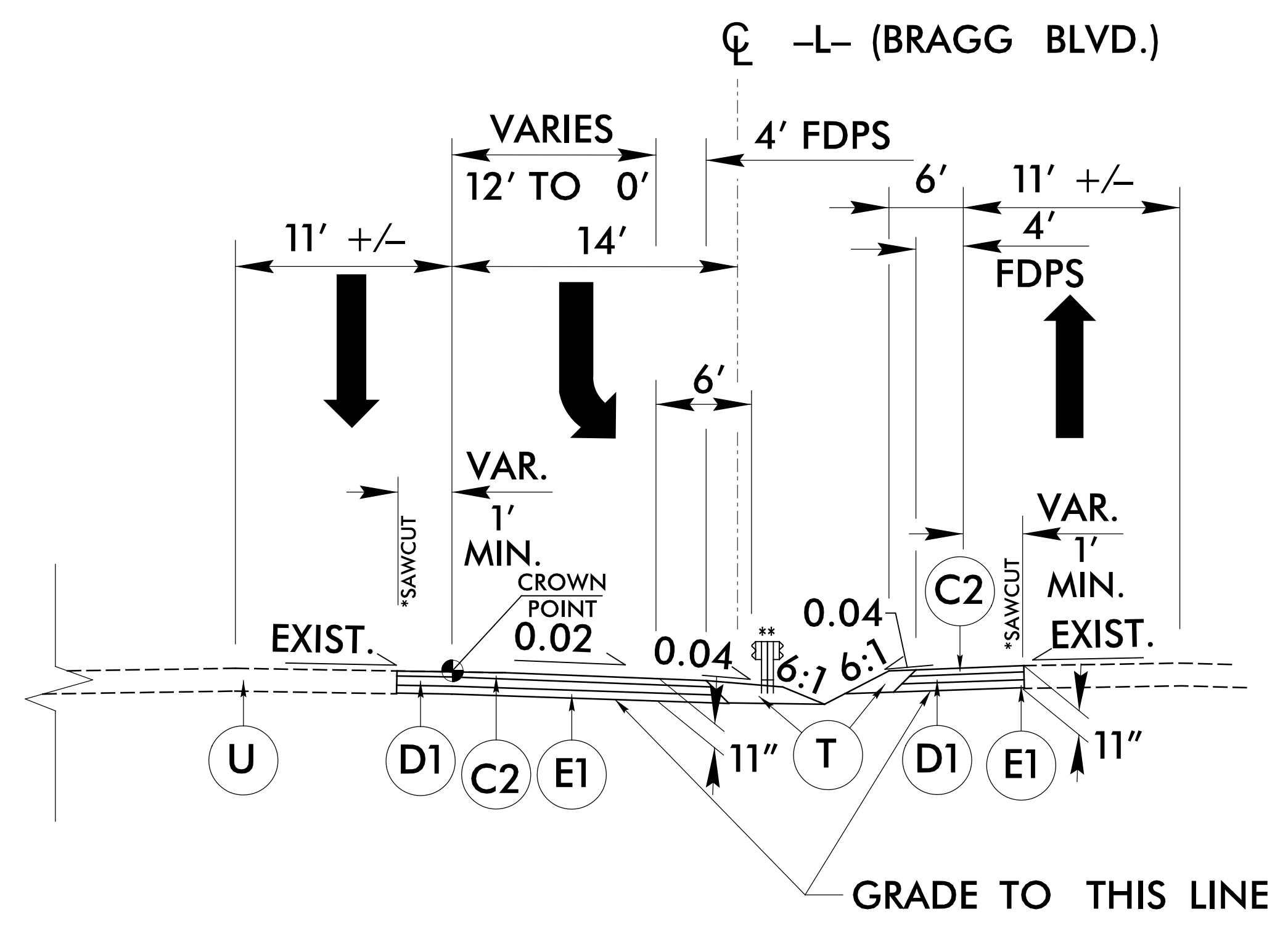

TYPICAL SECTION NO. 3

- L- STA. 73+30.00 TO STA. 75+68.19
- L- STA. 82+35.00 TO STA. 83+15.00 (MIRROR)

*SAWCUT MIN. 1' FROM EXIST. EOP
 **DOUBLE FACED GUARDRAIL. SEE PLANS FOR LOCATIONS.

5/12/2023
 JJJ-typ.dgn
 jrb

6/22/23

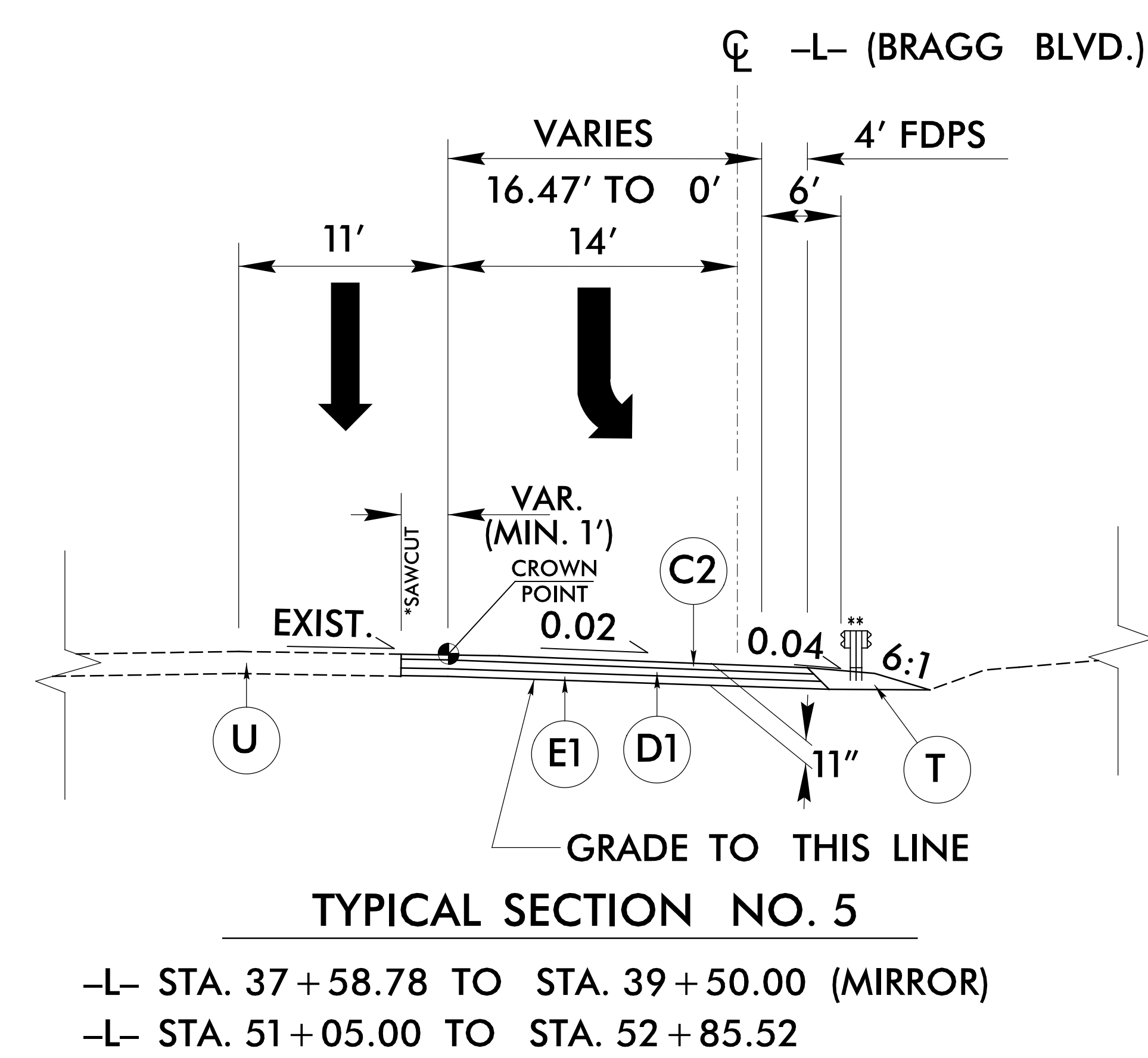
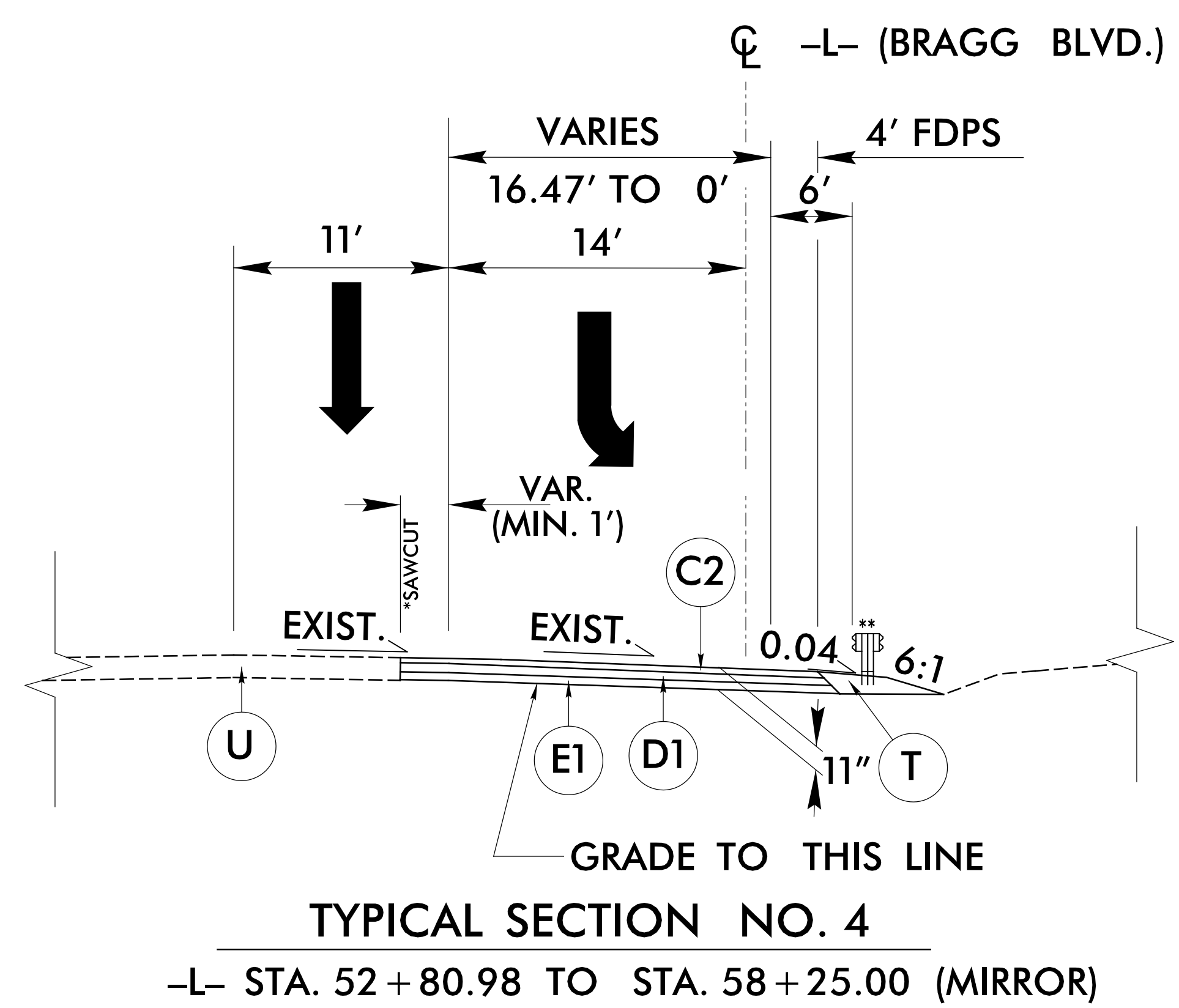

PROJECT REFERENCE NO. U-6229	SHEET NO. 2A-2
ROADWAY DESIGN ENGINEER J. B. JAYBLANK	PAVEMENT DESIGN ENGINEER D. KENDALL
5/11/2023	5/11/2023

DOCUMENT NOT CONSIDERED FINAL UNLESS ALL SIGNATURES COMPLETED

FINAL PAVEMENT SCHEDULE	
C1	1.5" TYPE S9.5C
C2	3" TYPE S9.5C
D1	4" TYPE I19.0C
E1	4" TYPE B25.0C
R2	2'-9" CURB AND GUTTER
R3	CONCRETE ISLAND (KEYED IN)
T	EARTH MATERIAL
U	EXISTING PAVEMENT
V	MILLING 1.5"

NOTE: SEE PLANS FOR TURN LANE LOCATIONS

*SAWCUT 1' FROM EXIST. EOP
**DOUBLE FACED GUARDRAIL. SEE PLANS FOR LOCATIONS.

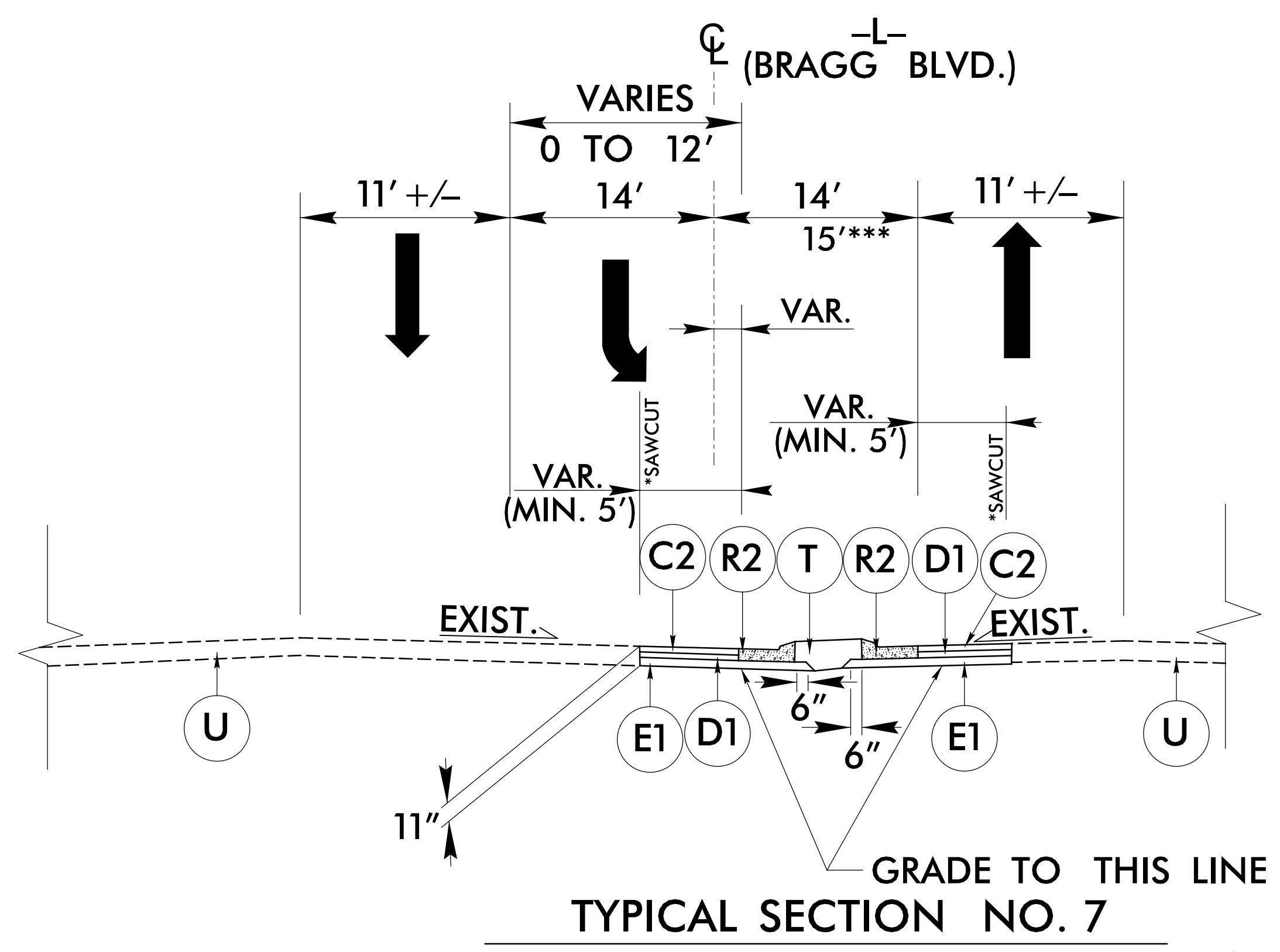
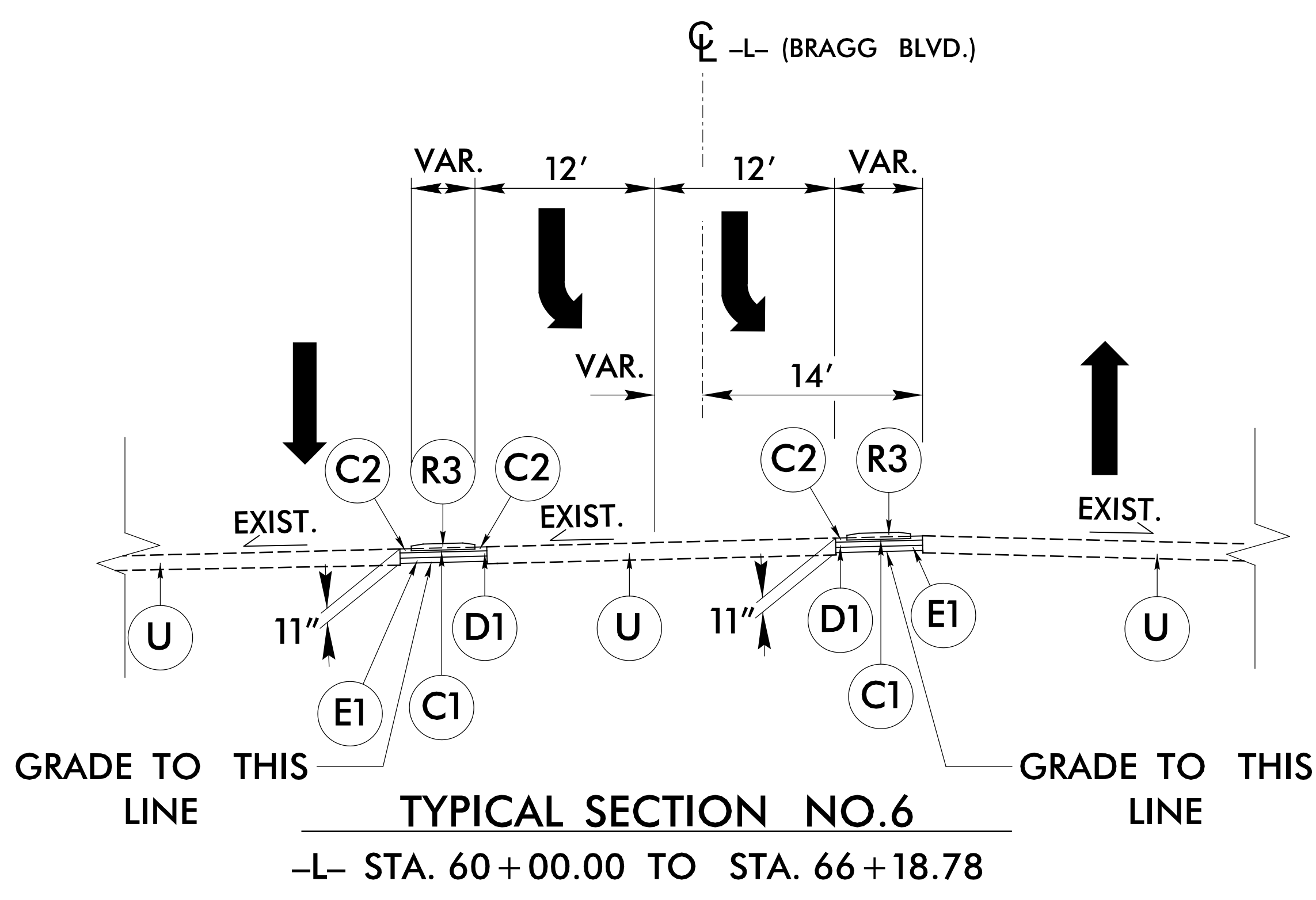

6/11/2023 djl-typ.dgn



PROJECT REFERENCE NO. U-6229	SHEET NO. 2A-3
ROADWAY DESIGN ENGINEER J. JAVELLA	PAVEMENT DESIGN ENGINEER D. KENDALL
5/11/2023	5/11/2023

DOCUMENT NOT CONSIDERED FINAL
UNLESS ALL SIGNATURES COMPLETED

FINAL PAVEMENT SCHEDULE	
C1	1.5" TYPE S9.5C
C2	3" TYPE S9.5C
D1	4" TYPE I19.0C
E1	4" TYPE B25.0C
R1	1'-6" CURB AND GUTTER
R2	2'-9" CURB AND GUTTER
R3	CONCRETE ISLAND (KEYED IN)
R4	4" CONCRETE COVER
T	EARTH MATERIAL
U	EXISTING PAVEMENT
V	MILLING 1.5"

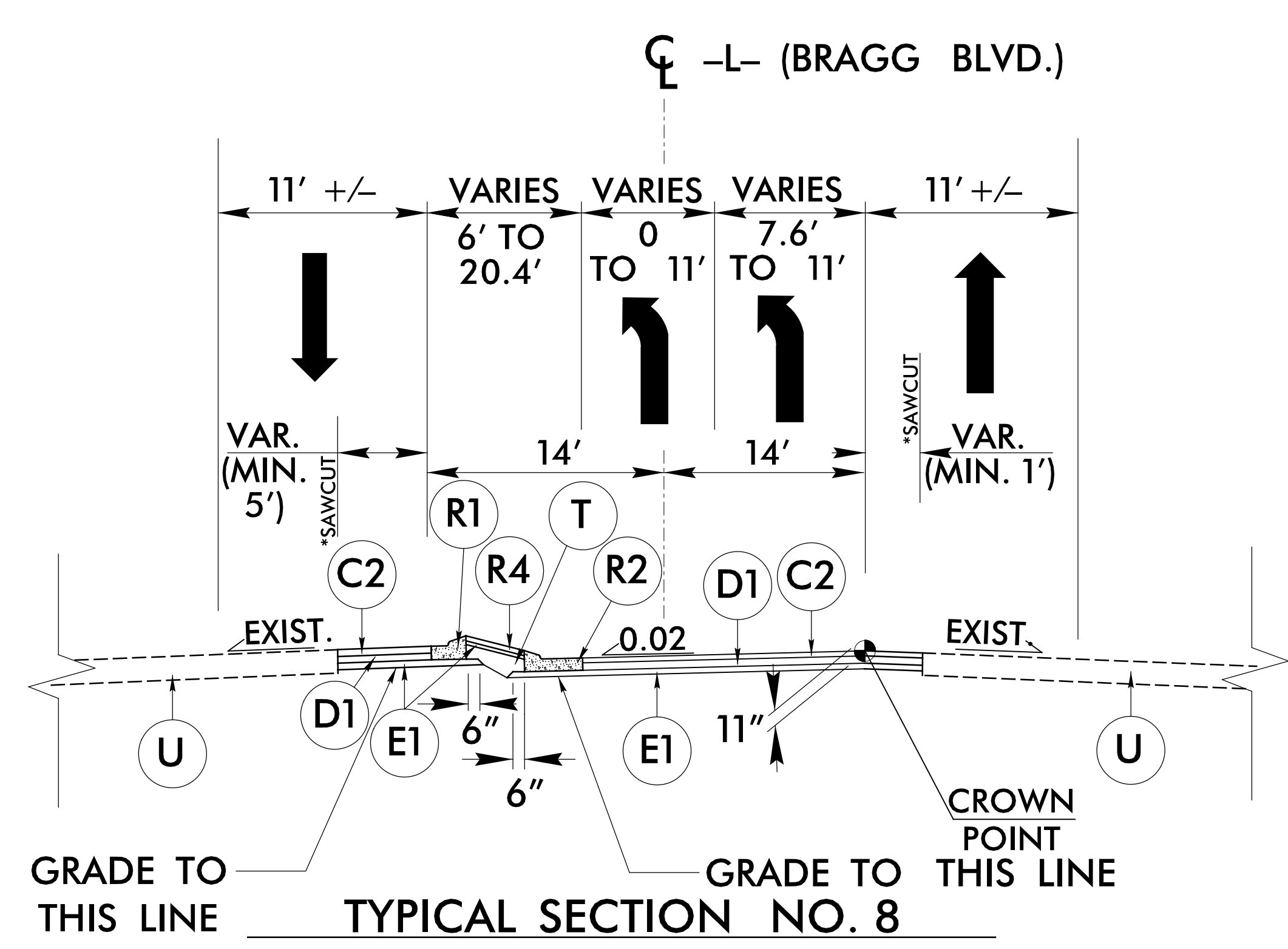

-L- STA. 83+15.00 TO STA. 87+85.00
-L- STA. 95+40.00 TO STA. 99+90.00

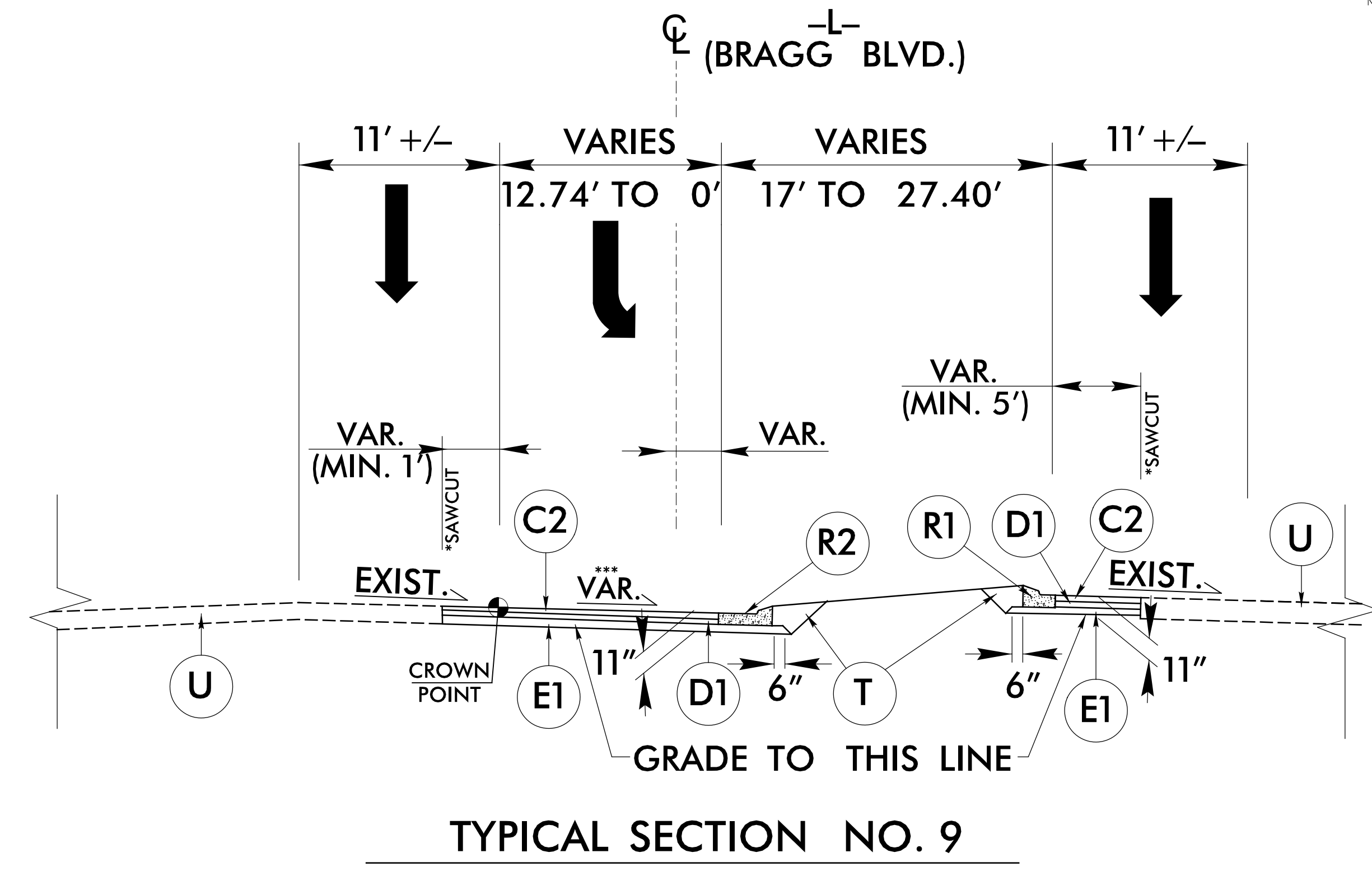

-L- STA. 91+00.00 TO STA. 94+40.00
-L- STA. 94+40.00 TO STA. 95+40.00 (MIRROR)

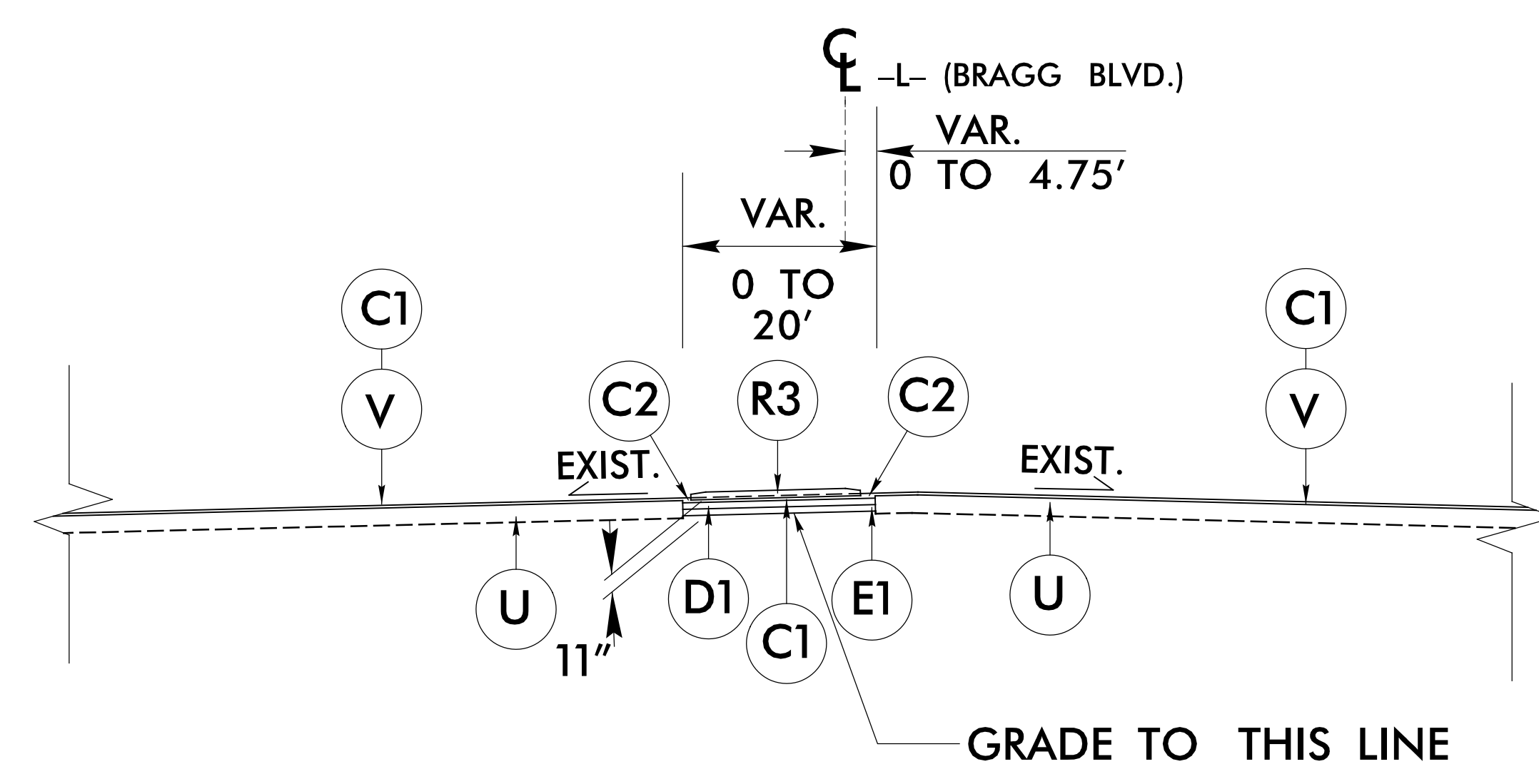

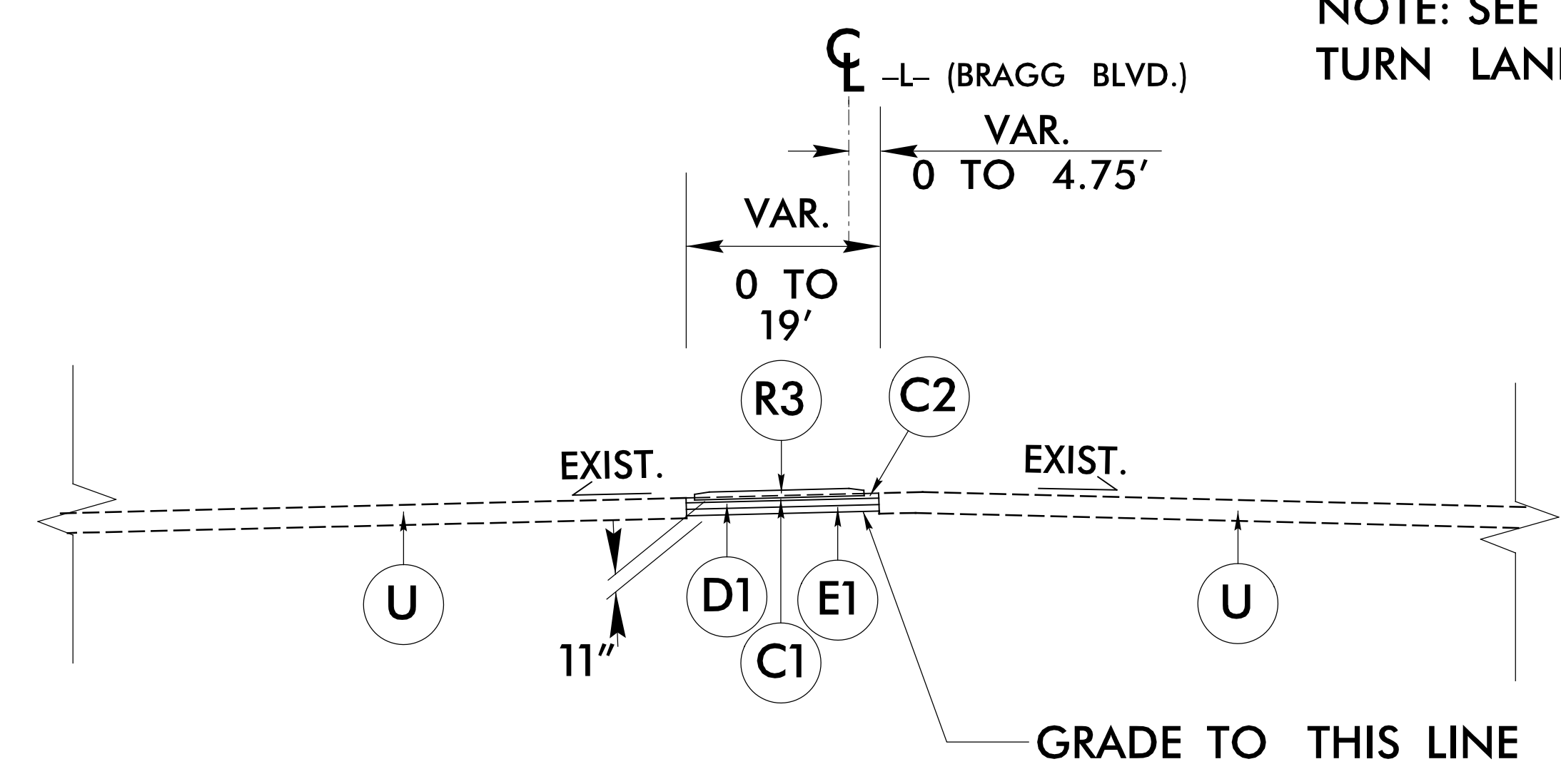

-L- STA. 58+25.00 TO STA. 60+00.00
-L- STA. 68+40.00 TO STA. 69+00.00
-L- STA. 69+00.00 TO STA. 69+55.00 (MIRROR)
-L- STA. 87+85.00 TO STA. 88+50.00
-L- STA. 88+50.00 TO STA. 89+35.00 (MIRROR)



-L- STA. 99+90.00 TO STA. 100+10.00
-L- STA. 100+70.50 TO STA. 100+80.00 (MIRROR)
-L- STA. 111+85.00 TO STA. 112+08.29

*SAWCUT MIN. 1' FROM EXIST. EOP
***SEE PLANS FOR TURN LANE SUPERS
NOTE: SEE PLANS FOR TURN LANE LOCATIONS

CONCRETE ISLAND DETAILS

PROJECT REFERENCE NO. U-6229	SHEET NO. 2B-1
ROADWAY DESIGN ENGINEER	
	
DOCUMENT NOT CONSIDERED FINAL UNLESS ALL SIGNATURES COMPLETED	
	

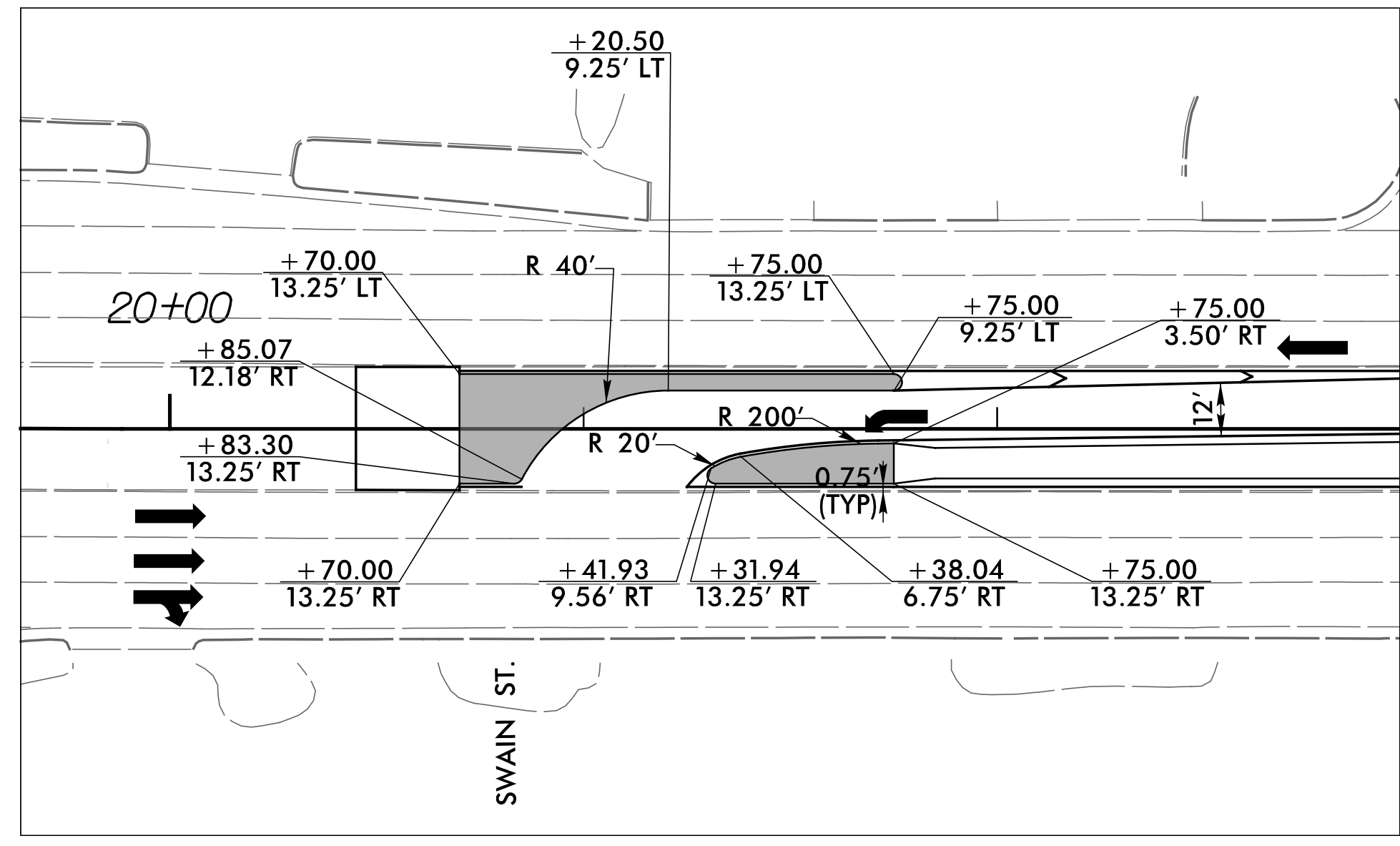

-L- STA. 20+70.00 TO STA. 21+77.00
SEE SHEET 4 FOR PLAN VIEW

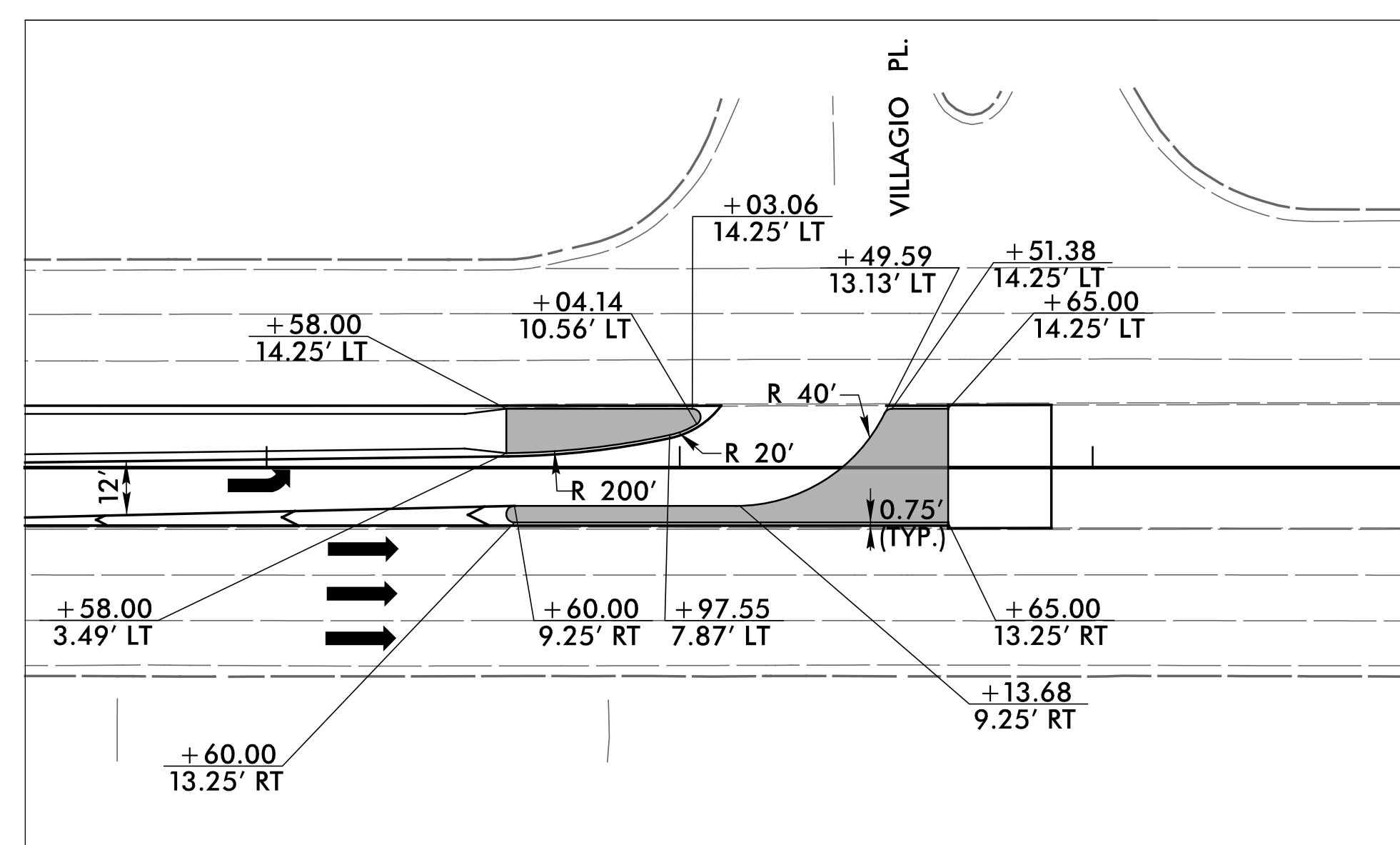

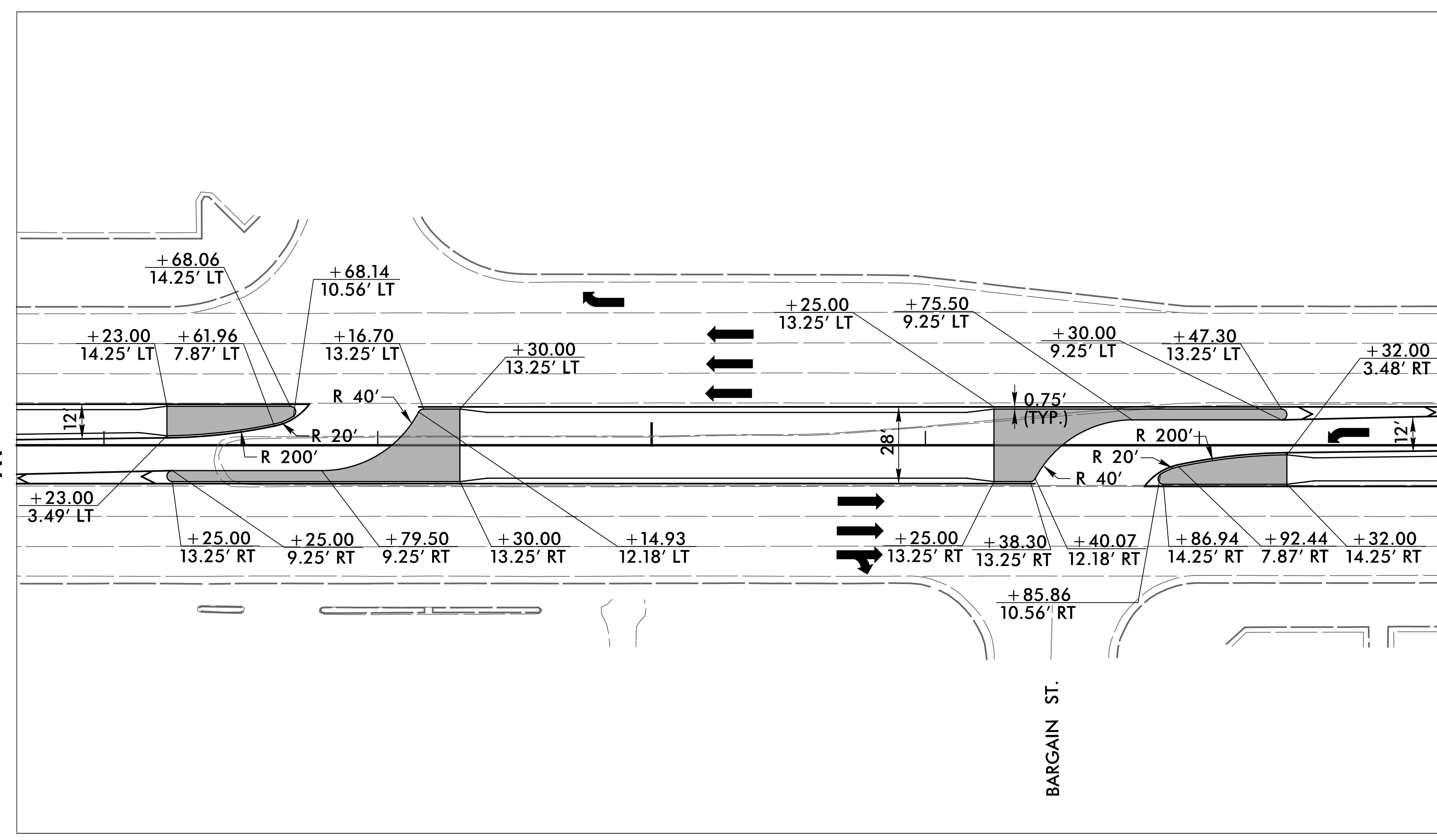

-L- STA. 31+58.00 TO STA. 32+65.00
SEE SHEET 5 FOR PLAN VIEW

NOTE:
 -NOT DRAWN TO SCALE
 -ALL ISLAND RADII 2'
 UNLESS OTHERWISE MARKED

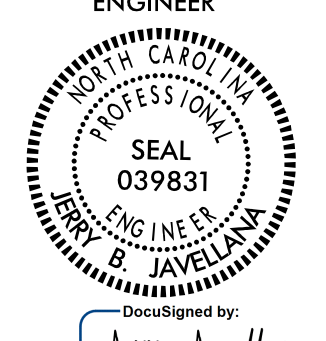
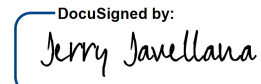

-L- STA. 43+23.00 TO STA. 47+32.00
SEE SHEET 6 FOR PLAN VIEW

PROJECT REFERENCE NO. U-6229	SHEET NO. 2B-2
ROADWAY DESIGN ENGINEER	
	
DOCUMENT NOT CONSIDERED FINAL UNLESS ALL SIGNATURES COMPLETED	
	

INTERSECTION DETAIL

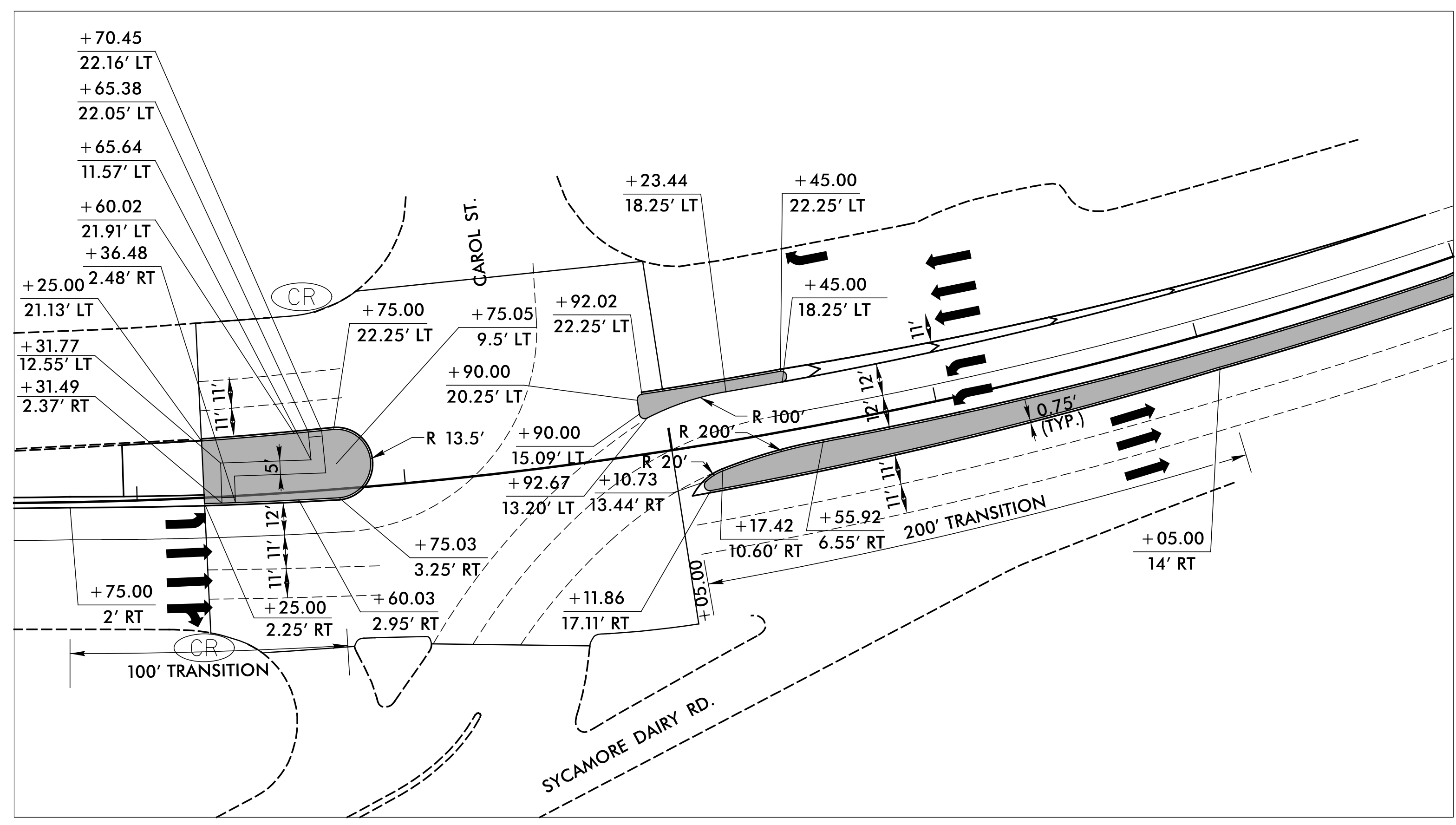

-L- STA. 56+50.00 TO STA. 63+00.00
SEE SHEET 7 FOR PLAN VIEW

NOTE:
 -NOT DRAWN TO SCALE
 -ALL ISLAND RADII 2'
 UNLESS OTHERWISE MARKED

STATE OF NORTH CAROLINA
DEPT. OF TRANSPORTATION
DIVISION OF HIGHWAYS
RALEIGH, N.C.

ENGLISH DETAIL DRAWING FOR
2'-9" CONCRETE CURB & GUTTER

SHEET 1 OF 1
846D01

- GENERAL NOTES:
- PLACE CONTRACTION JOINTS AT 10' INTERVALS, EXCEPT THAT A 15' SPACING MAY BE USED WHEN A MACHINE IS USED OR WHEN SATISFACTORY SUPPORT FOR THE FACE FORM CAN BE OBTAINED WITHOUT THE USE OF TEMPLATES AT 10' INTERVALS.
 - JOINT SPACING MAY BE ALTERED IF REQUIRED BY THE ENGINEER.
 - CONTRACTION JOINTS MAY BE INSTALLED WITH THE USE OF TEMPLATES OR FORMED BY OTHER APPROVED METHODS. MAKE NON-TEMPLATE FORMED JOINTS A MIN. OF 1½" DEEP.
 - FILL ALL CONSTRUCTION JOINTS WITH JOINT FILLER AND SEALER.
 - SPACE EXPANSION JOINTS AT 90' INTERVALS AND ADJACENT TO ALL RIGID OBJECTS.
 - SEE RDWY. STD. DWG. NO. 846.01, SHEET 2 OF 3 FOR PLACEMENT IN SUPERELEVATIONS. (USE 2'-6" CURB AND GUTTER RATES)

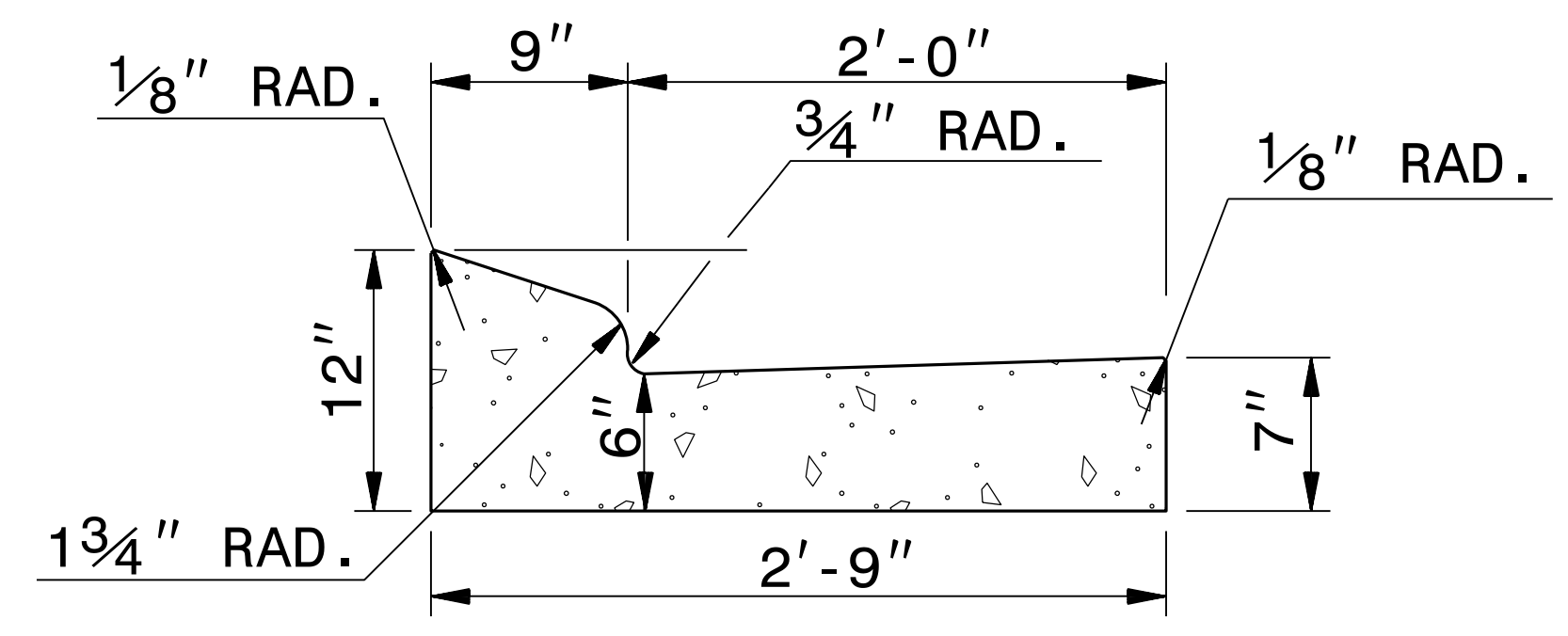

2'-9" CURB AND GUTTER

SECTION VIEW OF CURB AND GUTTER

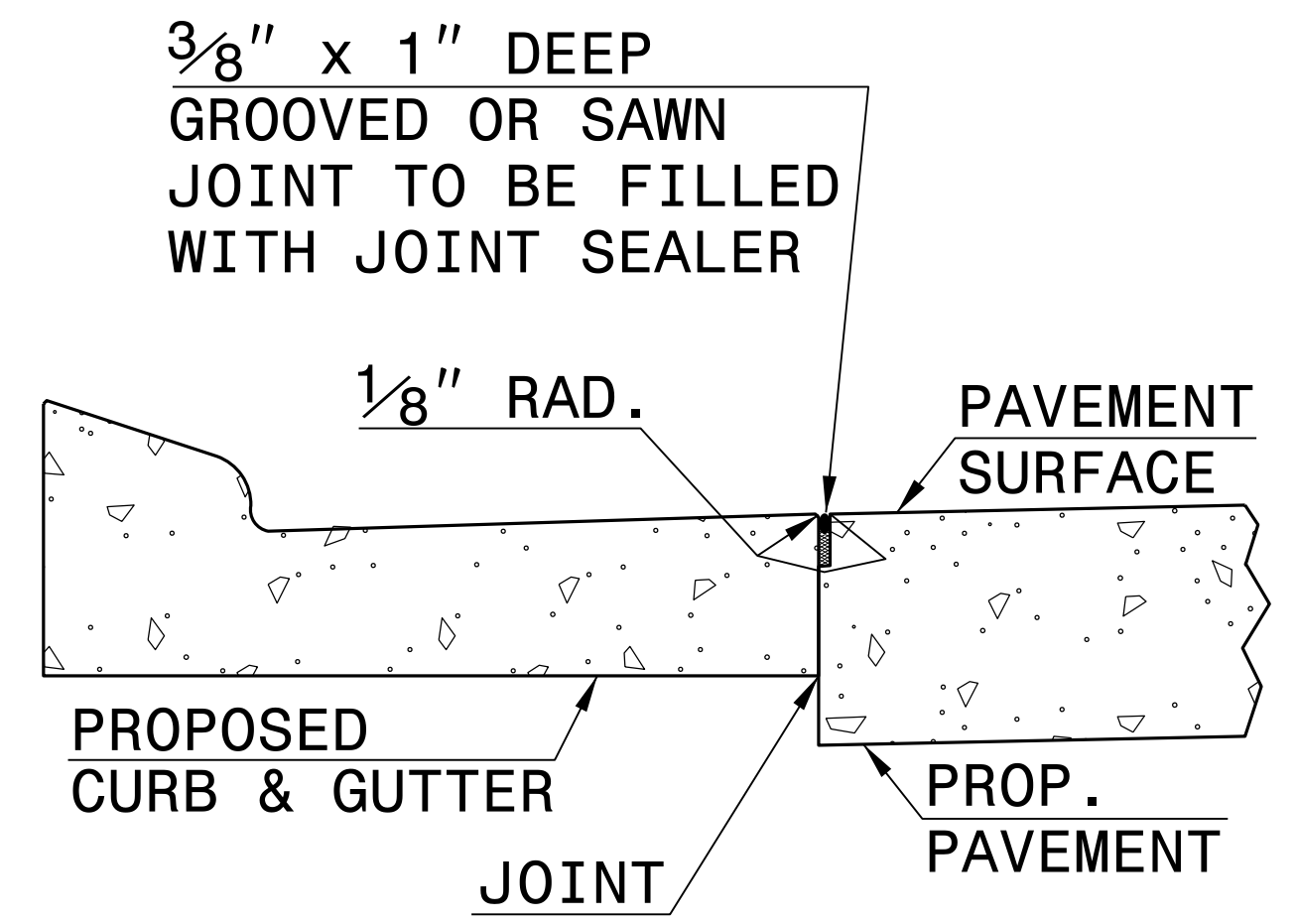

LONGITUDINAL JOINT

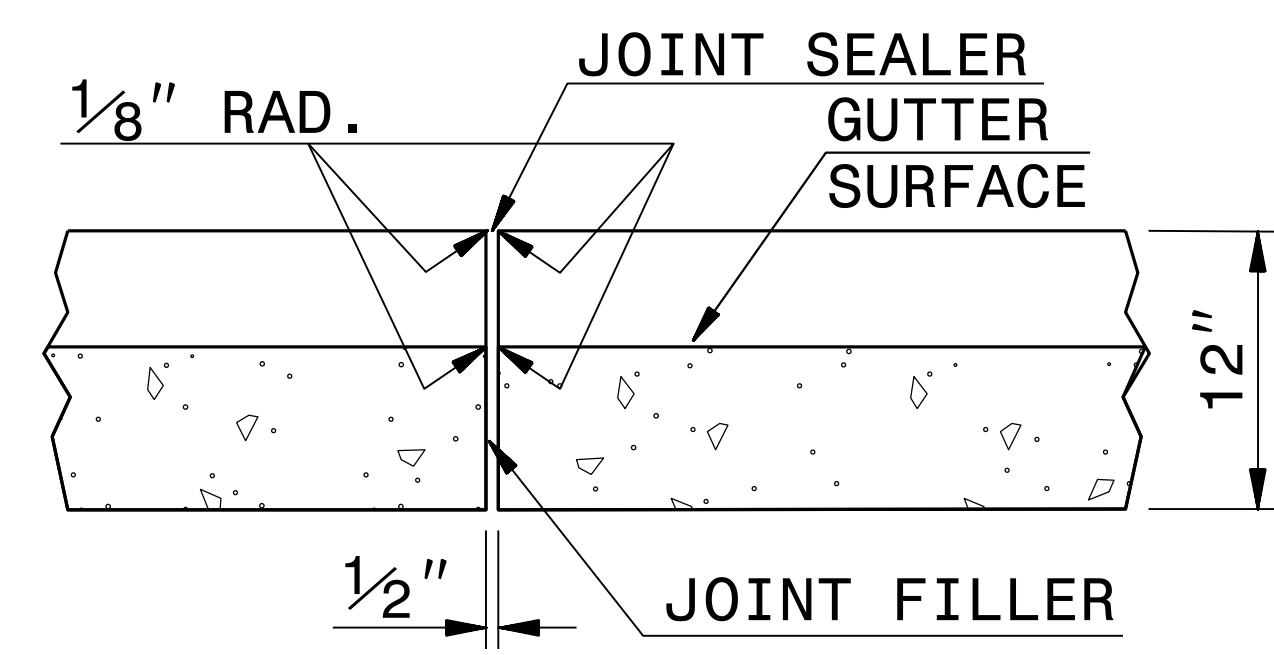

TRANSVERSE EXPANSION JOINT IN CURB AND GUTTER

SECTION VIEW OF JOINTS

STATE OF NORTH CAROLINA
DEPT. OF TRANSPORTATION
DIVISION OF HIGHWAYS
RALEIGH, N.C.

ENGLISH DETAIL DRAWING FOR
2'-9" CONCRETE CURB & GUTTER

SHEET 1 OF 1
846D01

J:\AUG-2017\1146-S:\Contracts\Special\Details\vertical\usr\details\stand\c&g2'-9.dgn
J:\power\ton AT_CSD-2\2595

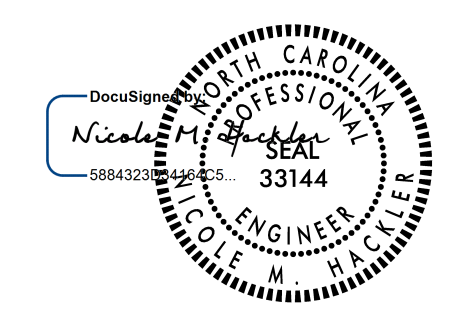

3/22/2023

DOCUMENT NOT CONSIDERED FINAL
UNLESS ALL SIGNATURES COMPLETED

CONTRACT STANDARDS AND DEVELOPMENT UNIT
Office 919-707-6950 FAX 919-250-4119

SEE PLATE FOR TITLE

ORIGINAL BY: STD. 846.01 DATE: _____
 MODIFIED BY: E.E. WARD DATE: 8-15-00
 CHECKED BY: _____ DATE: _____
 FILE SPEC.: /usr/details/stand/c&g2'-9.dgn

STATE OF NORTH CAROLINA
DEPT. OF TRANSPORTATION
DIVISION OF HIGHWAYS
RALEIGH, N.C.

ENGLISH DETAIL DRAWING FOR
**METHOD FOR PLACEMENT OF
DROP INLETS IN CONCRETE ISLANDS**

SHEET 1 OF 1
852D06

STATE OF NORTH CAROLINA
DEPT. OF TRANSPORTATION
DIVISION OF HIGHWAYS
RALEIGH, N.C.

ENGLISH DETAIL DRAWING FOR
**METHOD FOR PLACEMENT OF
DROP INLETS IN CONCRETE ISLANDS**

SHEET 1 OF 1
852D06

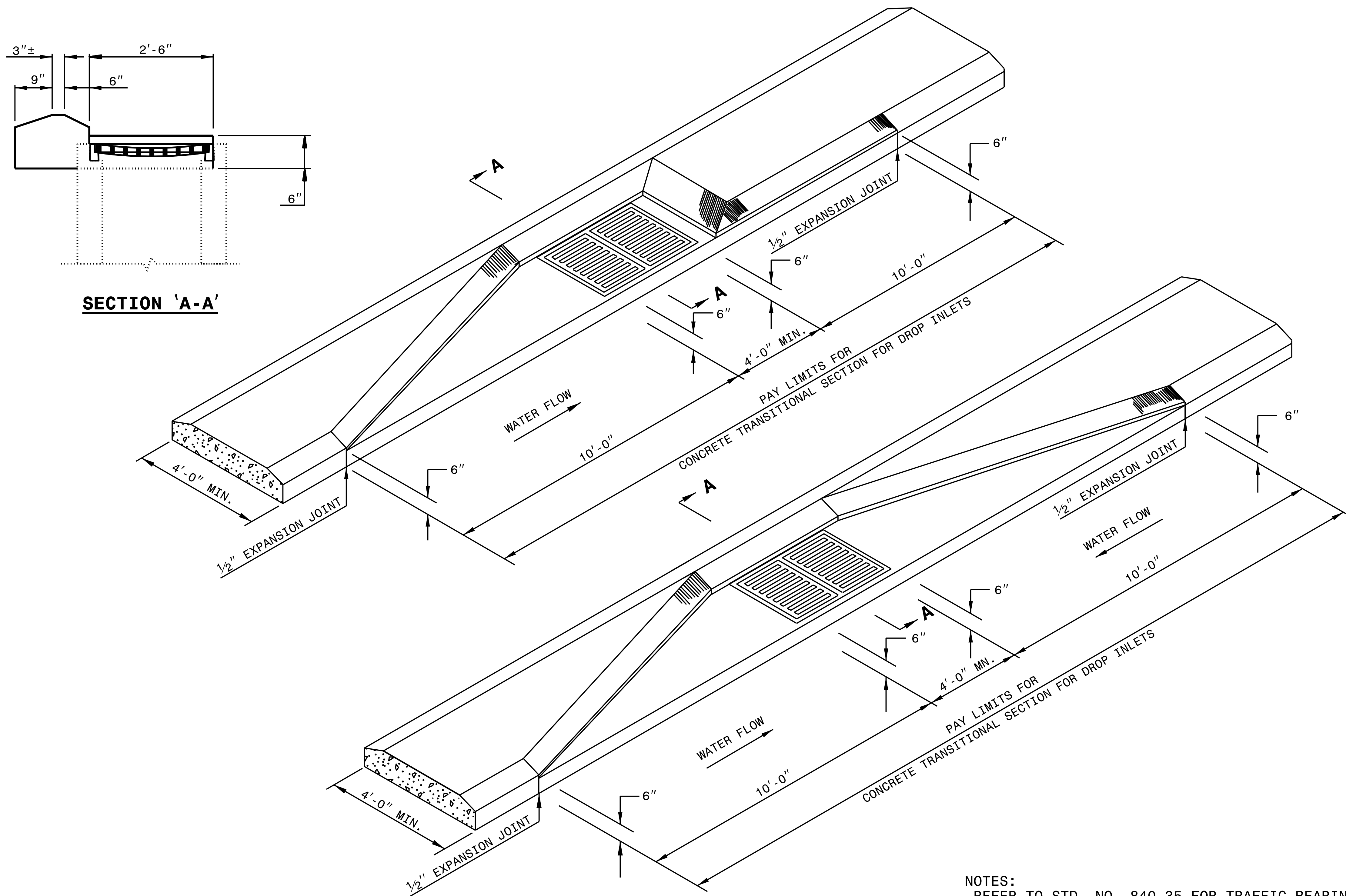

NOTES:
-REFER TO STD. NO. 840.35 FOR TRAFFIC BEARING DRAINAGE STRUCTURE.
-REFER TO STD. NO. 840.20 or 840.29 FOR GRATE AND FRAME.

\$\$\$SYTIME\$\$\$\$\$
\$\$\$SERIAL\$\$\$\$\$
\$\$\$PUERNAME\$\$\$\$\$

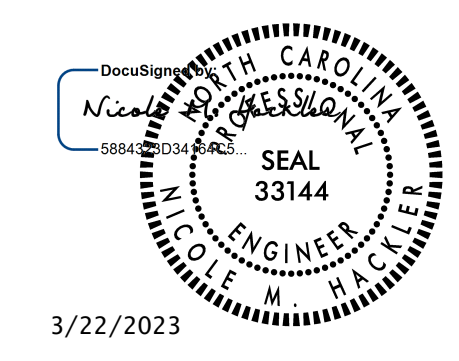

3/22/2023

DOCUMENT NOT CONSIDERED FINAL
UNLESS ALL SIGNATURES COMPLETED

CONTRACT STANDARDS AND DEVELOPMENT UNIT
Office 919-707-6950 FAX 919-250-4119

SEE TITLE PLATE

ORIGINAL BY: KKEMPF	DATE: 8/2/10
MODIFIED BY:	DATE:
CHECKED BY:	DATE:
FILE SPEC.: KKEMPF\ENGLISH\852D0601.DGN	

STATE OF
NORTH CAROLINA
DEPT. OF TRANSPORTATION
DIVISION OF HIGHWAYS
RALEIGH, N.C.

ROADWAY DETAIL DRAWING FOR
GUARDRAIL PLACEMENT
DOUBLE FACED W-BEAM

SHEET OF
862D01

STATE OF
NORTH CAROLINA
DEPT. OF TRANSPORTATION
DIVISION OF HIGHWAYS
RALEIGH, N.C.

ROADWAY DETAIL DRAWING FOR
GUARDRAIL PLACEMENT
DOUBLE FACED W-BEAM

SHEET OF
862D01

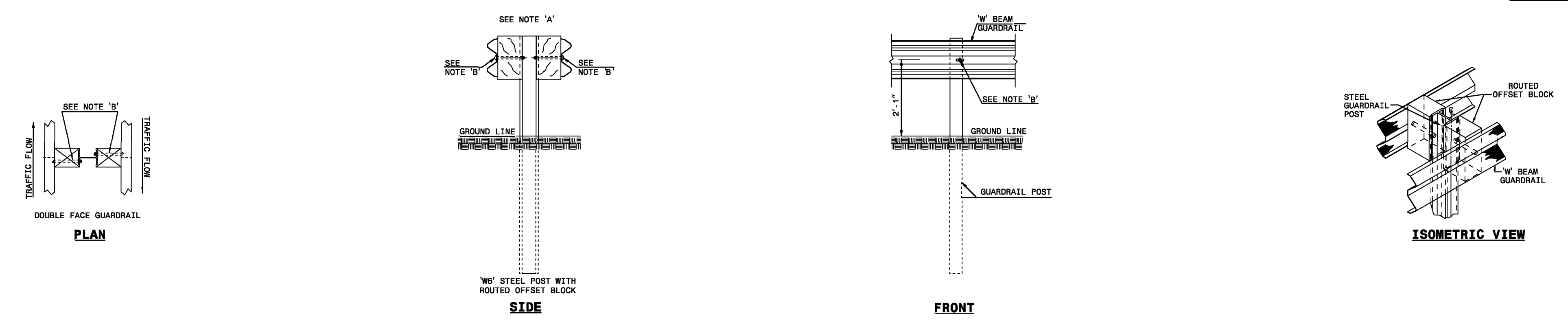

DRAWING NOT TO SCALE

NOTES:
A - 5/8" DIA. BUTTON HEAD SPLICE BOLT 1 1/4" LONG (8 REQ. PER SPLICE JOINT).
B - 5/8" DIA. BUTTON HEAD BOLT 7 1/2" LONG WITH NUT FOR BOLTING 6" W-BEAM ROUTED OFFSET BLOCK TO STEEL POSTS.
C - FIELD PUNCHING OF HOLES INTO GUARDRAIL AS DIRECTED BY THE ENGINEER.

TYPICAL GUARDRAIL AND GUARDRAIL POST ALTERNATIVES

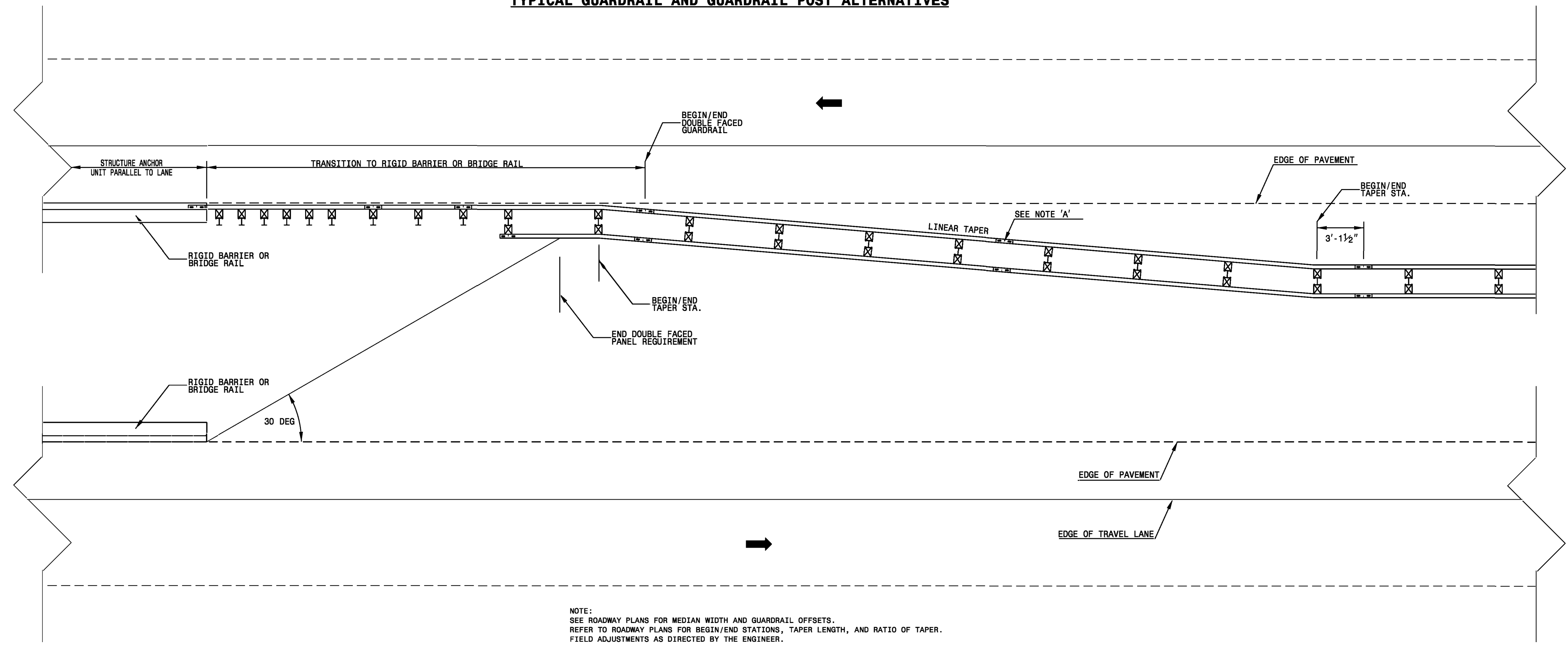

NOTE:
SEE ROADWAY PLANS FOR MEDIAN WIDTH AND GUARDRAIL OFFSETS.
REFER TO ROADWAY PLANS FOR BEGIN/END STATIONS, TAPER LENGTH, AND RATIO OF TAPER.
FIELD ADJUSTMENTS AS DIRECTED BY THE ENGINEER.

APPROACH TO RIGID BARRIER OR BRIDGE RAIL

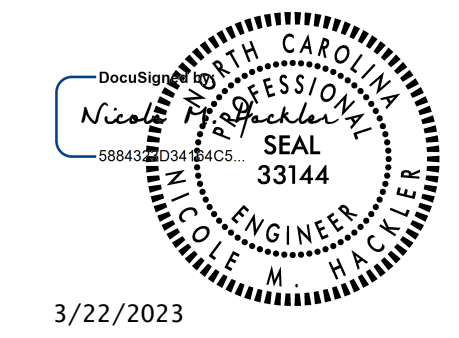

3/22/2023

DOCUMENT NOT CONSIDERED FINAL
UNLESS ALL SIGNATURES COMPLETED

CONTRACTS STANDARDS AND DEVELOPMENT UNIT
Office 919-707-6950 FAX 919-250-4119

GUARDRAIL PLACEMENT DOUBLE FACED W-BEAM

ORIGINAL BY: _____ DATE: _____
 MODIFIED BY: _____ DATE: _____
 CHECKED BY: _____ DATE: _____
 FILE SPEC.: _____

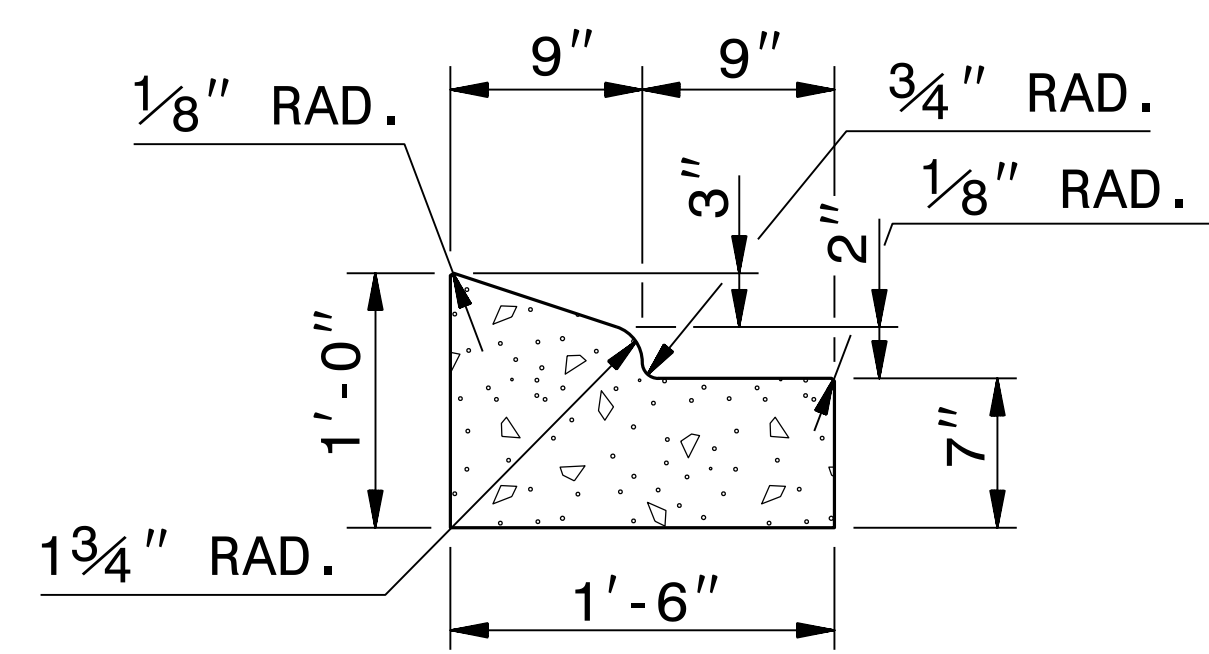

1'-6" CURB AND GUTTER

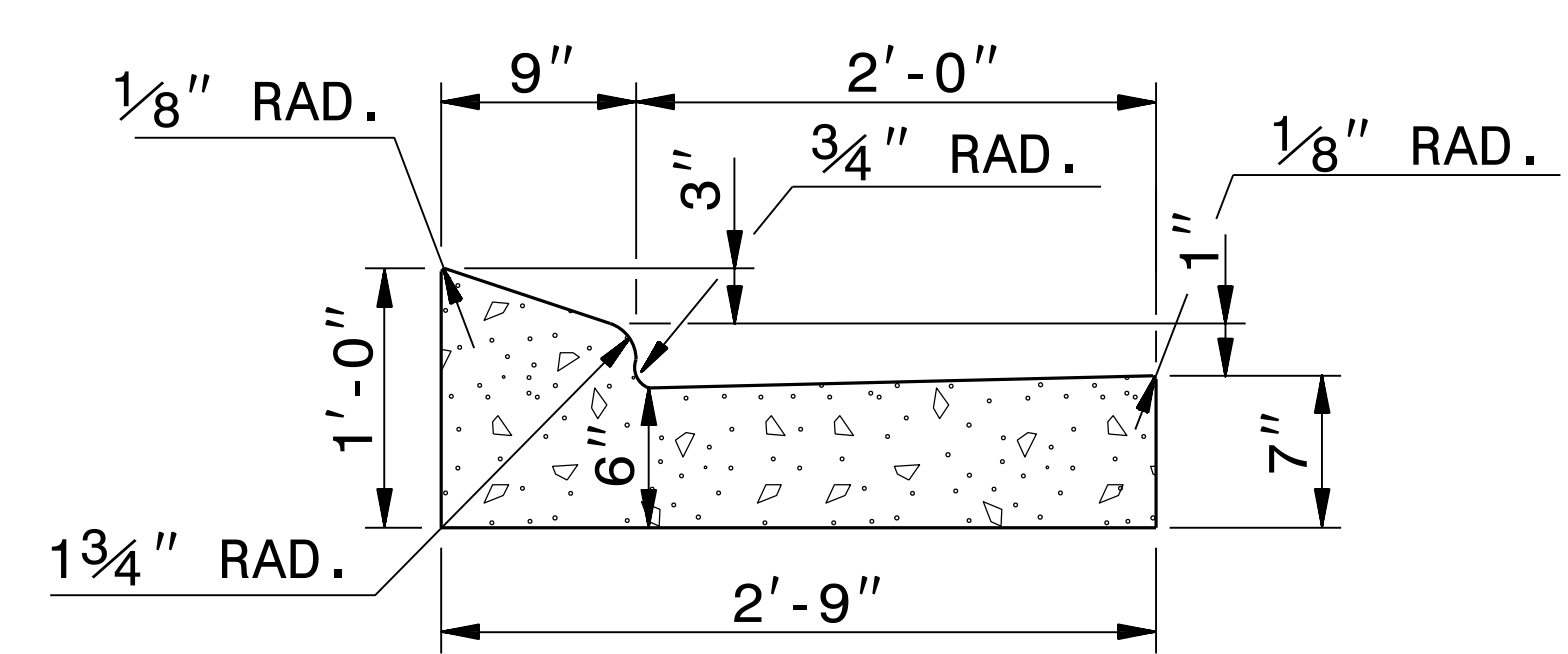

2'-9" CURB AND GUTTER

NOTE: SEE STD. DWG. 846.01 FOR ADDITIONAL CURB AND GUTTER INFORMATION.

SEE ROADWAY PLANS FOR LOCATION OF CURB TRANSITION.

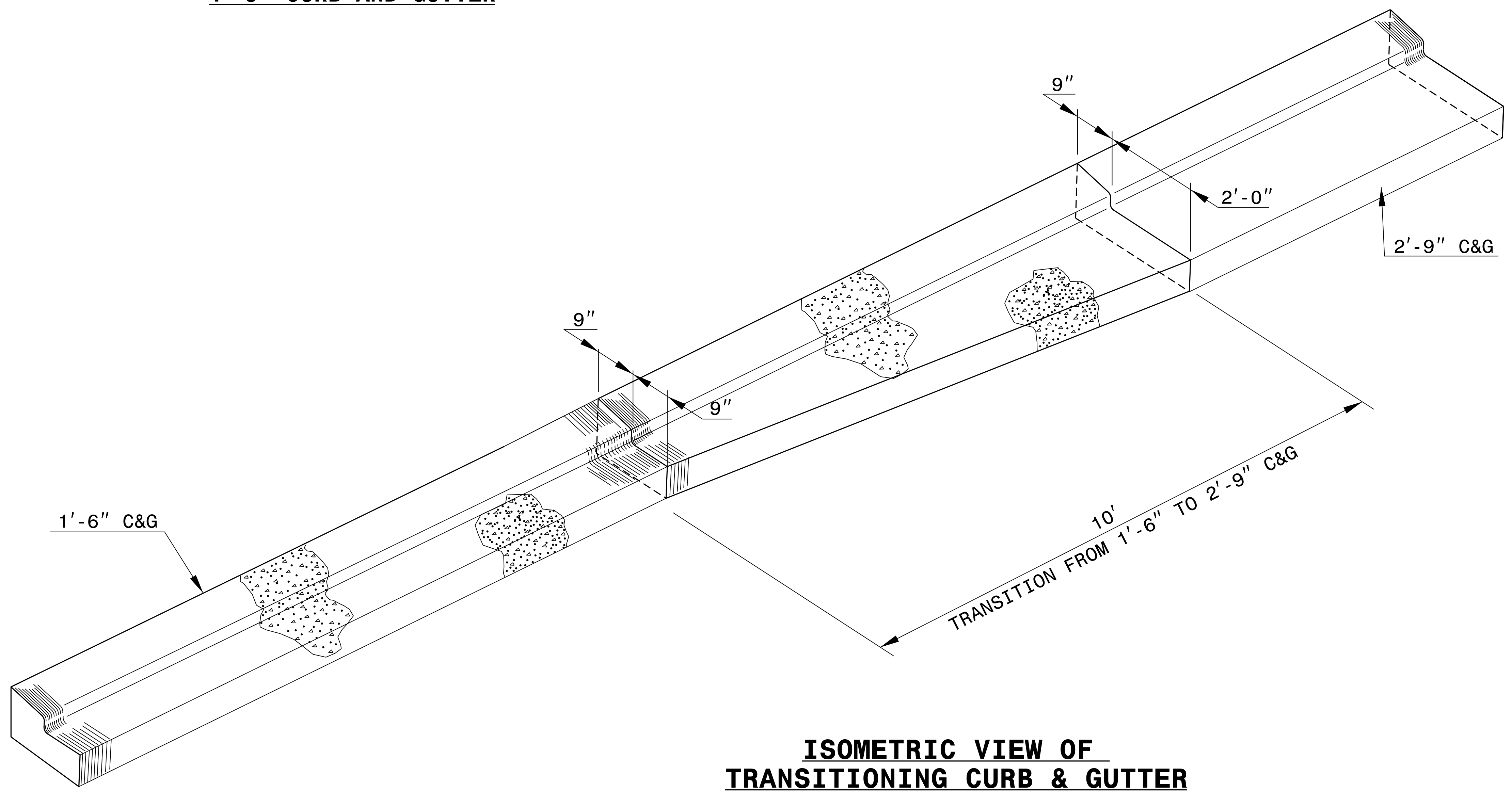

**ISOMETRIC VIEW OF
TRANSITIONING CURB & GUTTER**

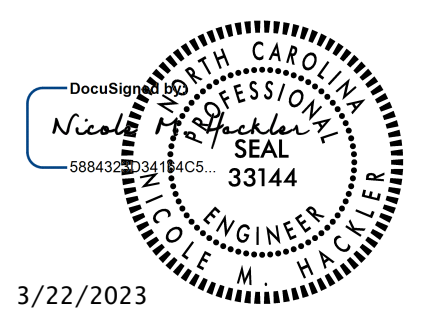

3/22/2023

DOCUMENT NOT CONSIDERED FINAL
UNLESS ALL SIGNATURES COMPLETED

**CONTRACT STANDARDS
AND DEVELOPMENT UNIT**
Office 919-707-6950 FAX 919-250-4119

**DETAIL OF 1'-6"
TO 2'-9" CURB & GUTTER
TRANSITION SECTION**

ORIGINAL BY: T.S.SPELL DATE: NOV. 26, 2001
 MODIFIED BY: T.S.SPELL DATE: JAN. 23, 2007
 CHECKED BY: DATE:
 FILE SPEC.: DS174:/usr/details/stand/cotransit.dgn

04-SEP-2018 08:31 S:\Contracts\Special Details\Howerton\Standard Drawings\Details in Lieu of Standards\Division 8\862D01 Impact Attenuator Sheets 1 and 2.dgn
 Jhowerton AT: CSU-212595

STATE OF NORTH CAROLINA
 DEPT. OF TRANSPORTATION
 DIVISION OF HIGHWAYS
 RALEIGH, N.C.

ROADWAY DETAIL DRAWING FOR
GUARDRAIL PLACEMENT

SHEET 1 OF 11
862D01

STATE OF NORTH CAROLINA
 DEPT. OF TRANSPORTATION
 DIVISION OF HIGHWAYS
 RALEIGH, N.C.

ROADWAY DETAIL DRAWING FOR
GUARDRAIL PLACEMENT

SHEET 1 OF 11
862D01

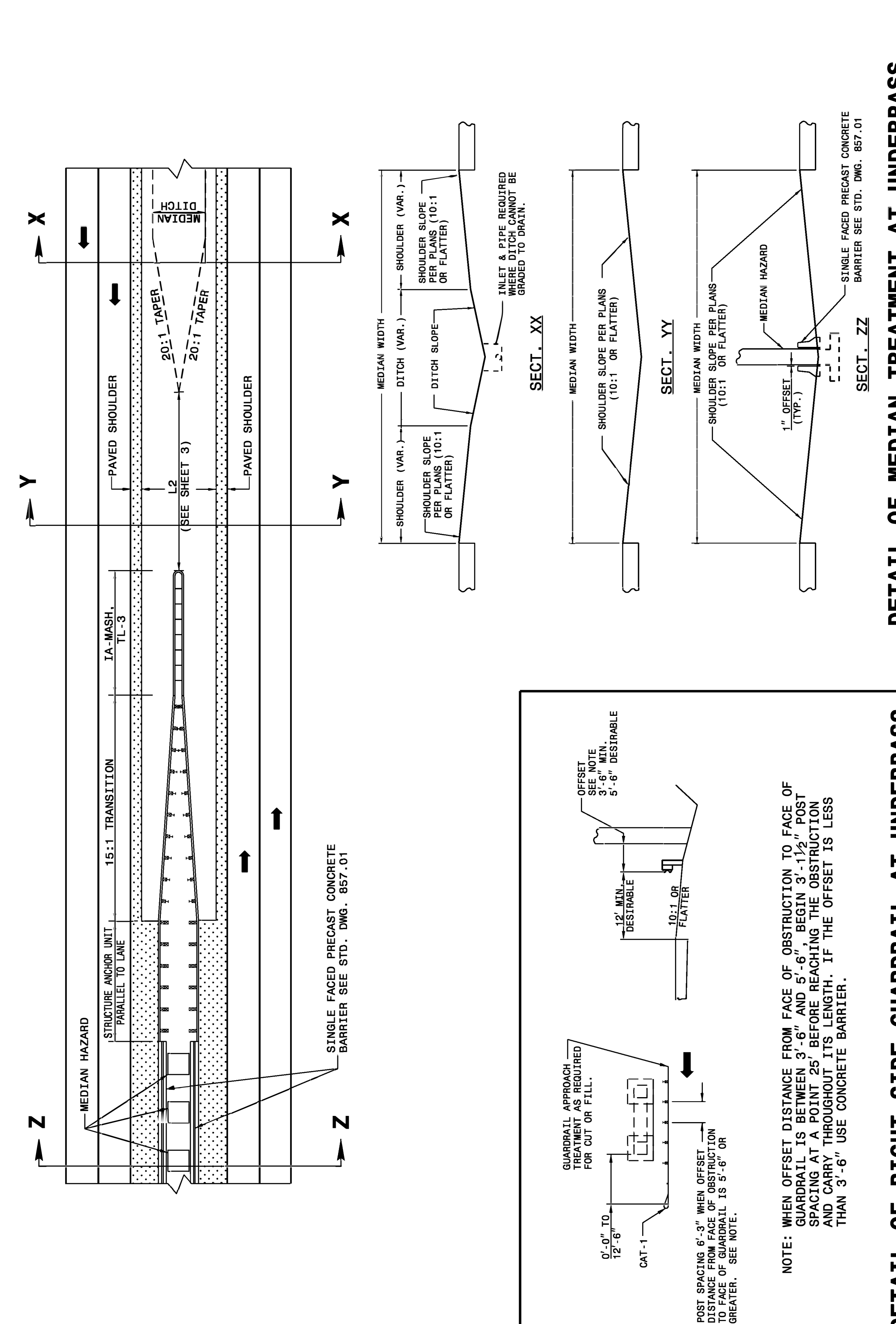

STATE OF NORTH CAROLINA
 DEPT. OF TRANSPORTATION
 DIVISION OF HIGHWAYS
 RALEIGH, N.C.

ROADWAY DETAIL DRAWING FOR
GUARDRAIL PLACEMENT

SHEET 2 OF 11
862D01

STATE OF NORTH CAROLINA
 DEPT. OF TRANSPORTATION
 DIVISION OF HIGHWAYS
 RALEIGH, N.C.

ROADWAY DETAIL DRAWING FOR
GUARDRAIL PLACEMENT

SHEET 2 OF 11
862D01

STATE OF NORTH CAROLINA
 DEPT. OF TRANSPORTATION
 DIVISION OF HIGHWAYS
 RALEIGH, N.C.

ROADWAY DETAIL DRAWING FOR
GUARDRAIL PLACEMENT

SHEET 2 OF 11
862D01

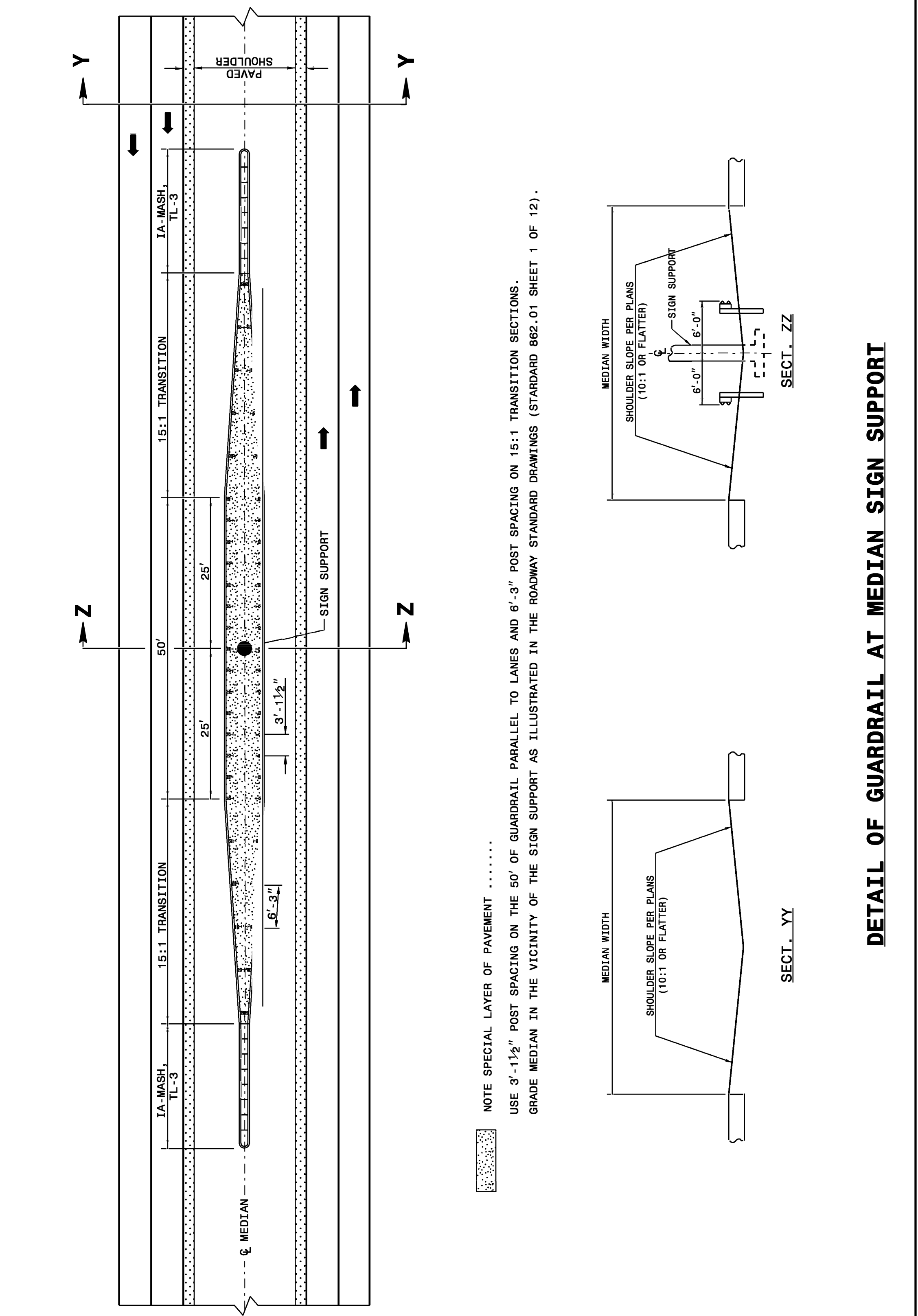

STATE OF NORTH CAROLINA
 DEPT. OF TRANSPORTATION
 DIVISION OF HIGHWAYS
 RALEIGH, N.C.

ROADWAY DETAIL DRAWING FOR
GUARDRAIL PLACEMENT

SHEET 2 OF 11
862D01

DOCUMENT NOT CONSIDERED FINAL
 UNLESS ALL SIGNATURES COMPLETED

CONTRACT STANDARDS AND DEVELOPMENT UNIT
 Office 919-707-6950 FAX 919-250-4119

SEE TITLE BLOCK

ORIGINAL BY: J HOWERTON DATE: 08-23-18
 MODIFIED BY: DATE: _____
 CHECKED BY: DATE: _____
 FILE SPEC.: DATE: _____

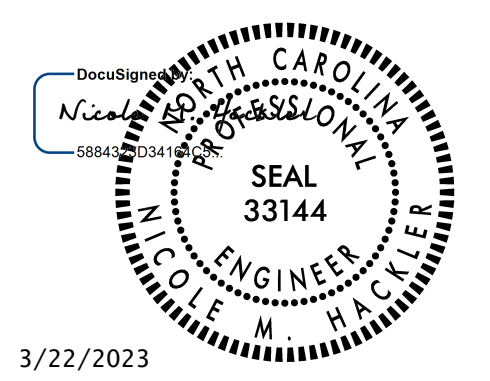

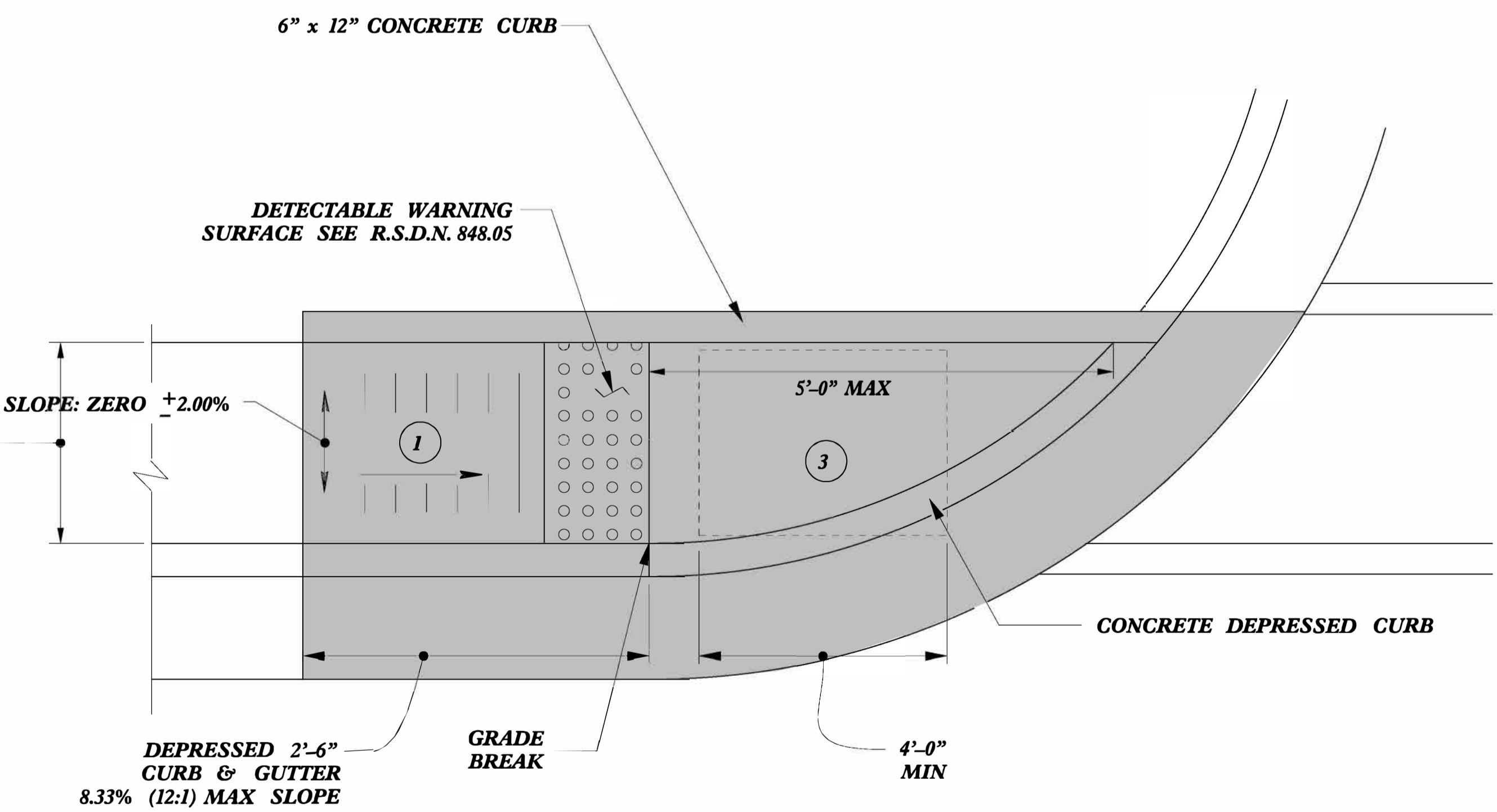
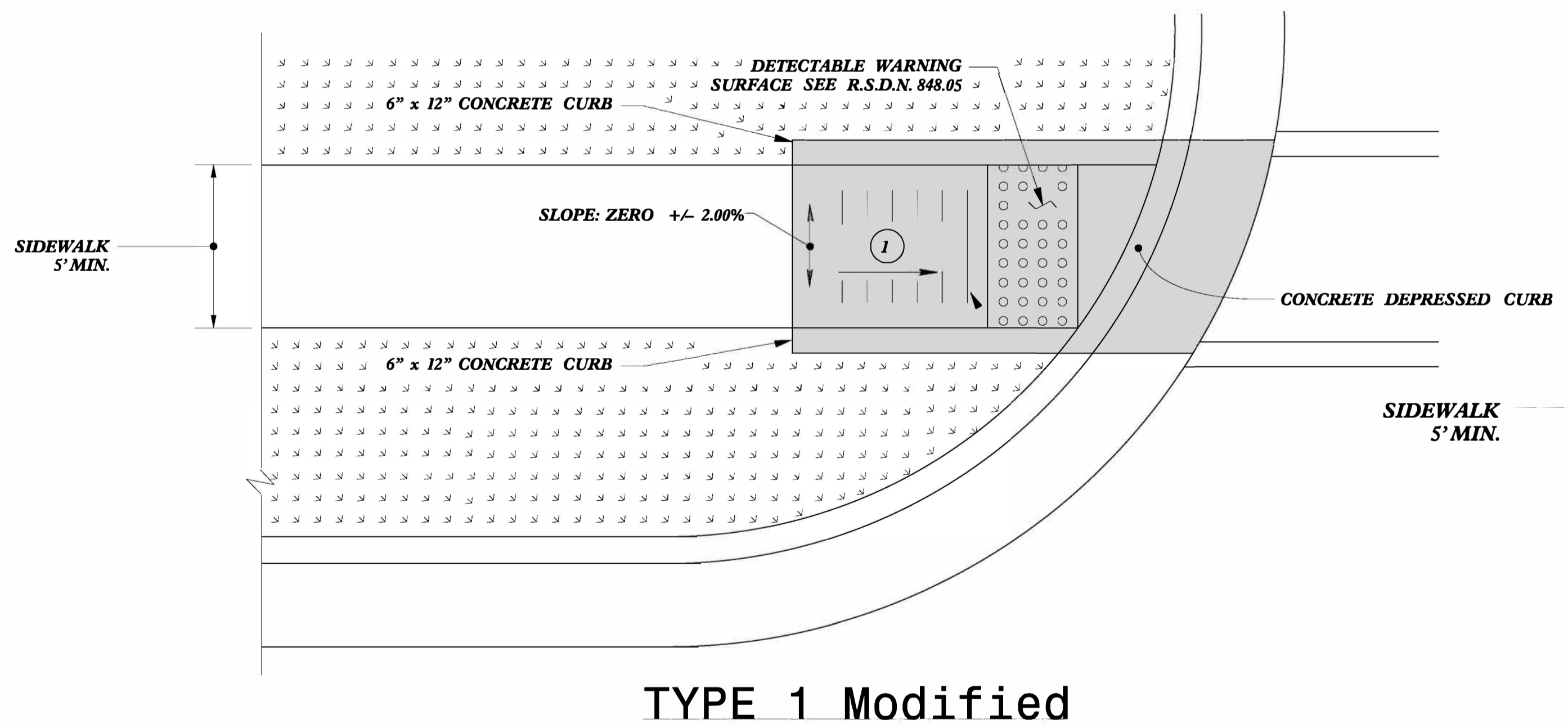
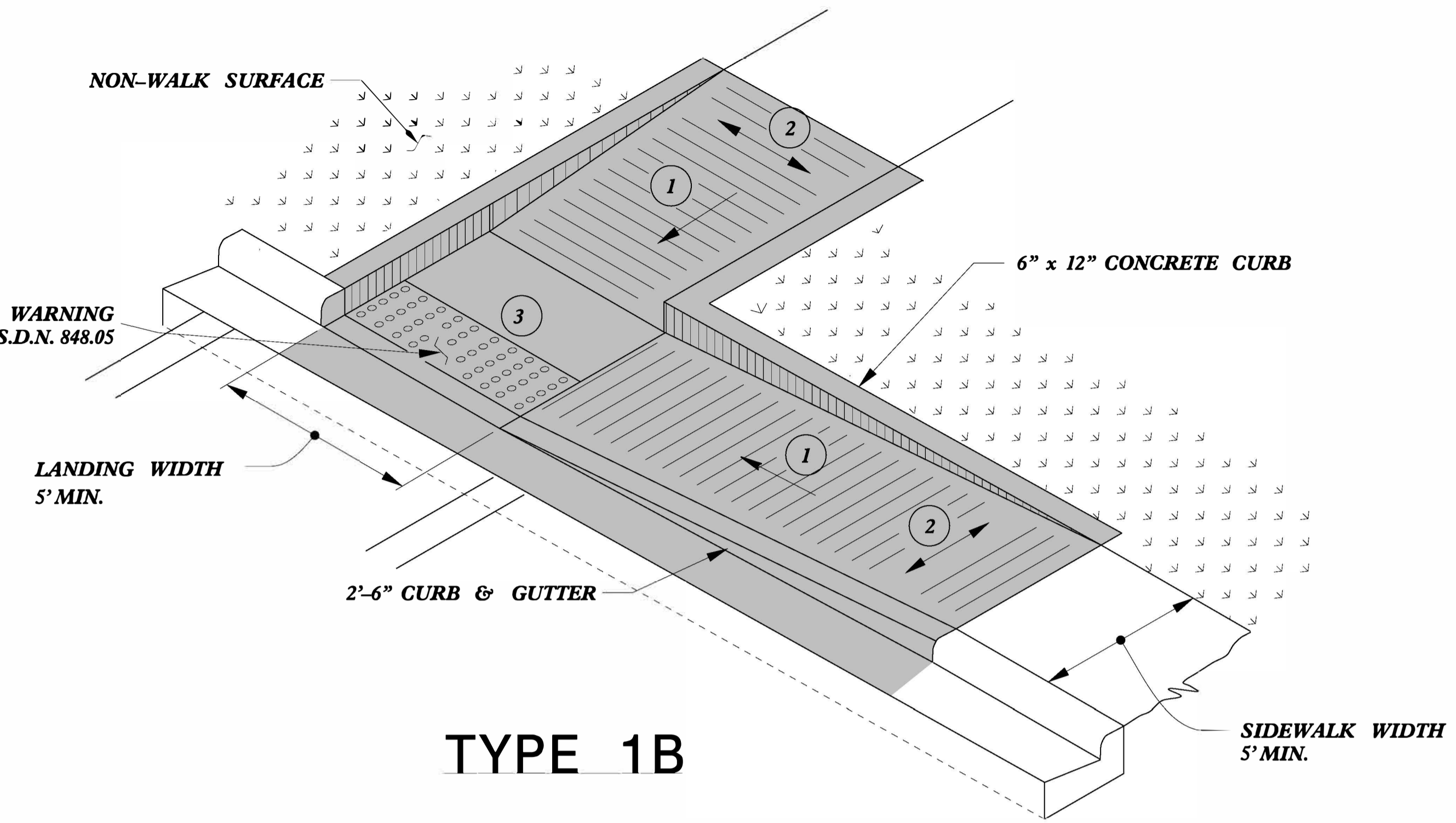
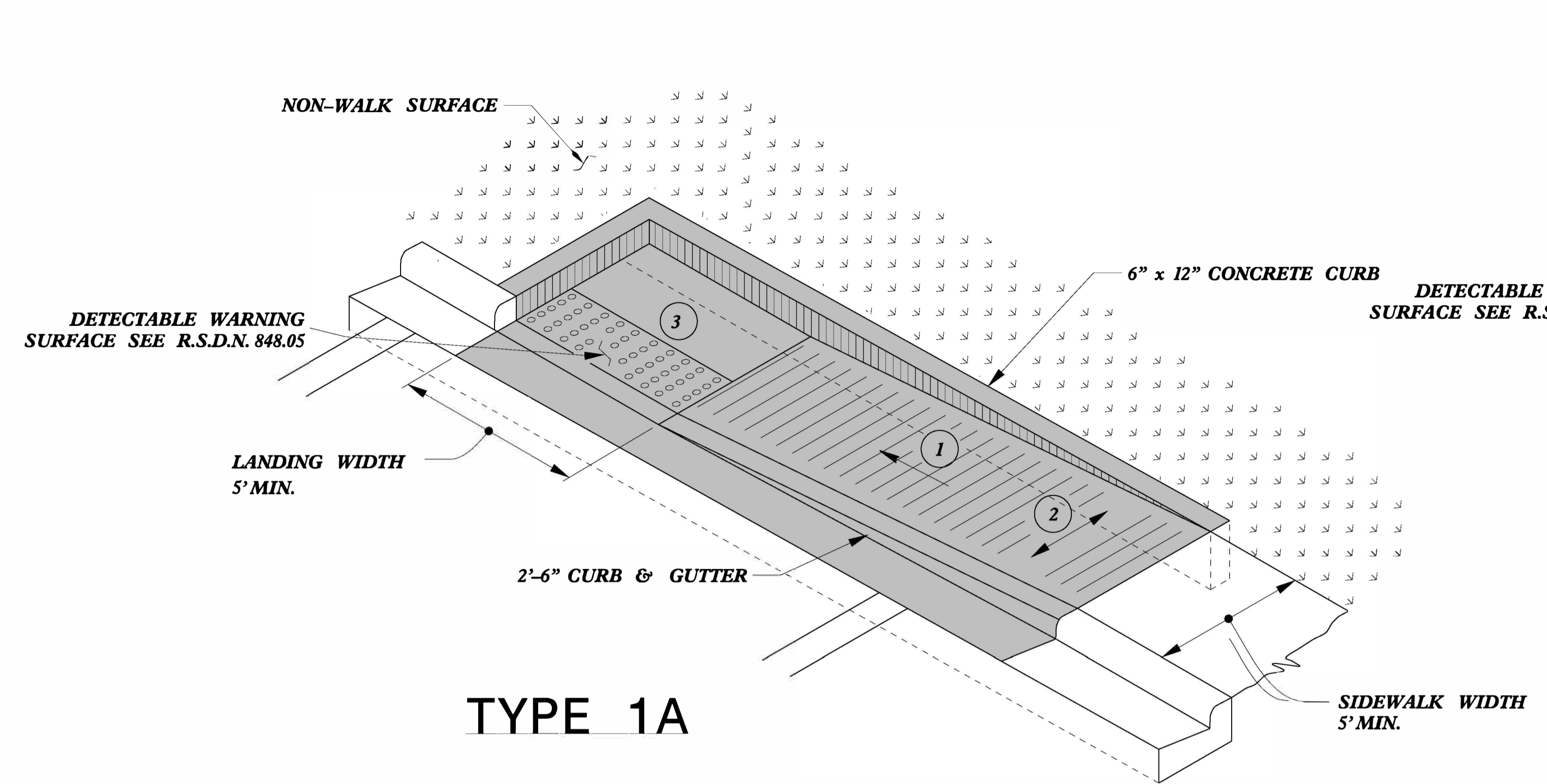

- 1 8.33% (12:1) MAX RAMP SLOPE
- 2 CROSS SLOPE: 2.00%
- 3 CURB RAMPS REQUIRE A (4'-0") MINIMUM LANDING WITH A MAXIMUM CROSS SLOPE AND LONGITUDINAL SLOPE OF 2.00% WHERE PEDESTRIANS PERFORM TURNING MANEUVERS. SLOPE TO DRAIN TO CURB.

PAY LIMITS FOR 1 CURB RAMP

REFER TO ROADWAY STANDARD DRAWING NUMBER 848.05 SHEET 3 OF 3 FOR ALL RAMP NOTES

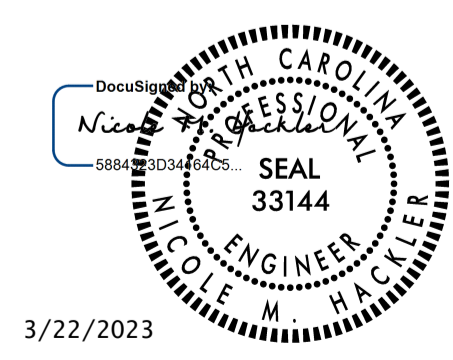

DOCUMENT NOT CONSIDERED FINAL UNLESS ALL SIGNATURES COMPLETED

CONTRACT STANDARDS AND DEVELOPMENT UNIT
Office 919-707-6950 FAX 919-250-4119

CURB RAMPS
Directional Ramps

ORIGINAL BY: J.S. HOWERTON DATE: 7/7/11
 MODIFIED BY: _____ DATE: _____
 CHECKED BY: _____ DATE: _____
 FILE SPEC: stds/2012CurbRamp/CurbRampDetails.dgn

PAY LIMITS FOR 1 CURB RAMP

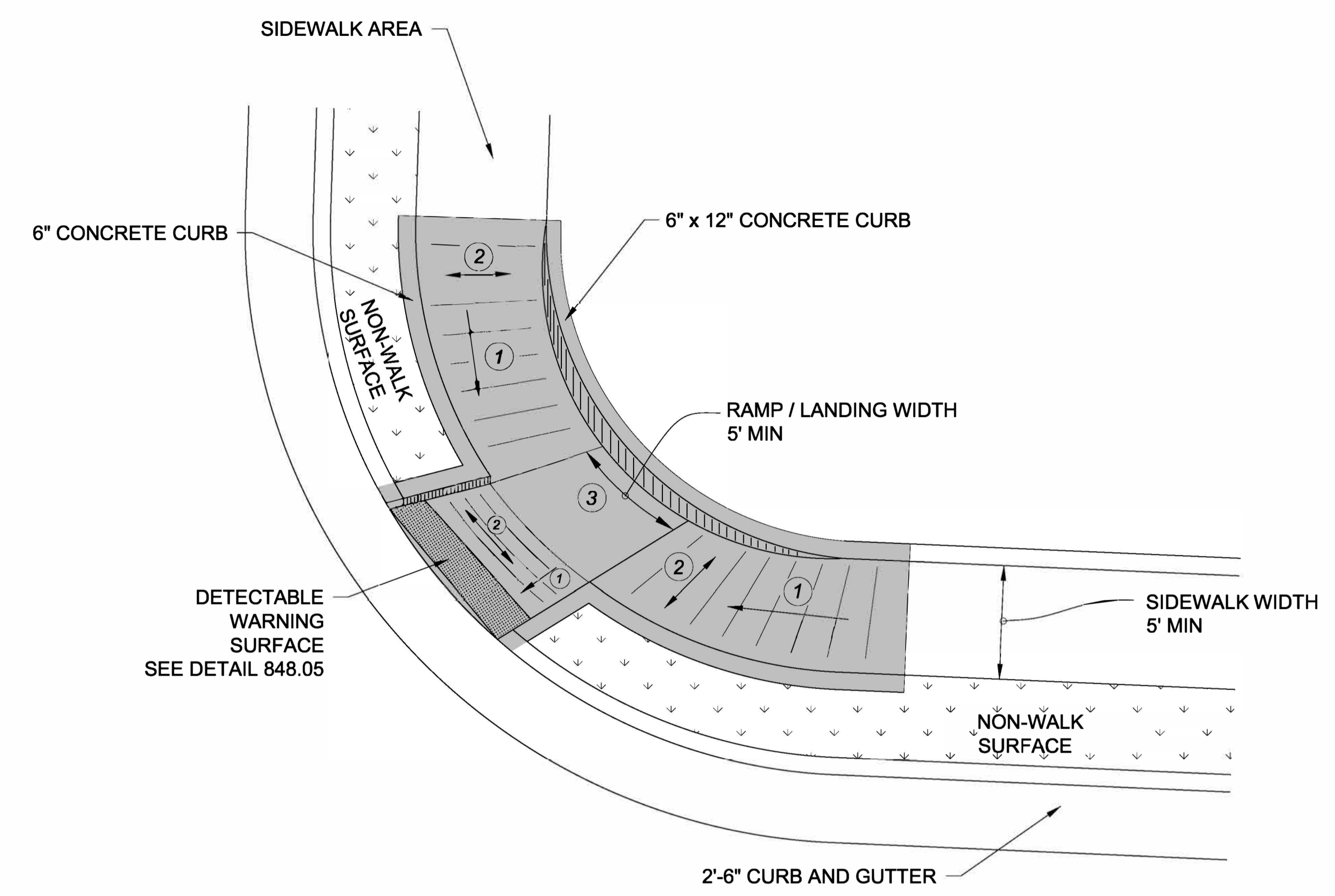

TYPE 3 MODIFIED
INSTALLATION IN A RADIUS

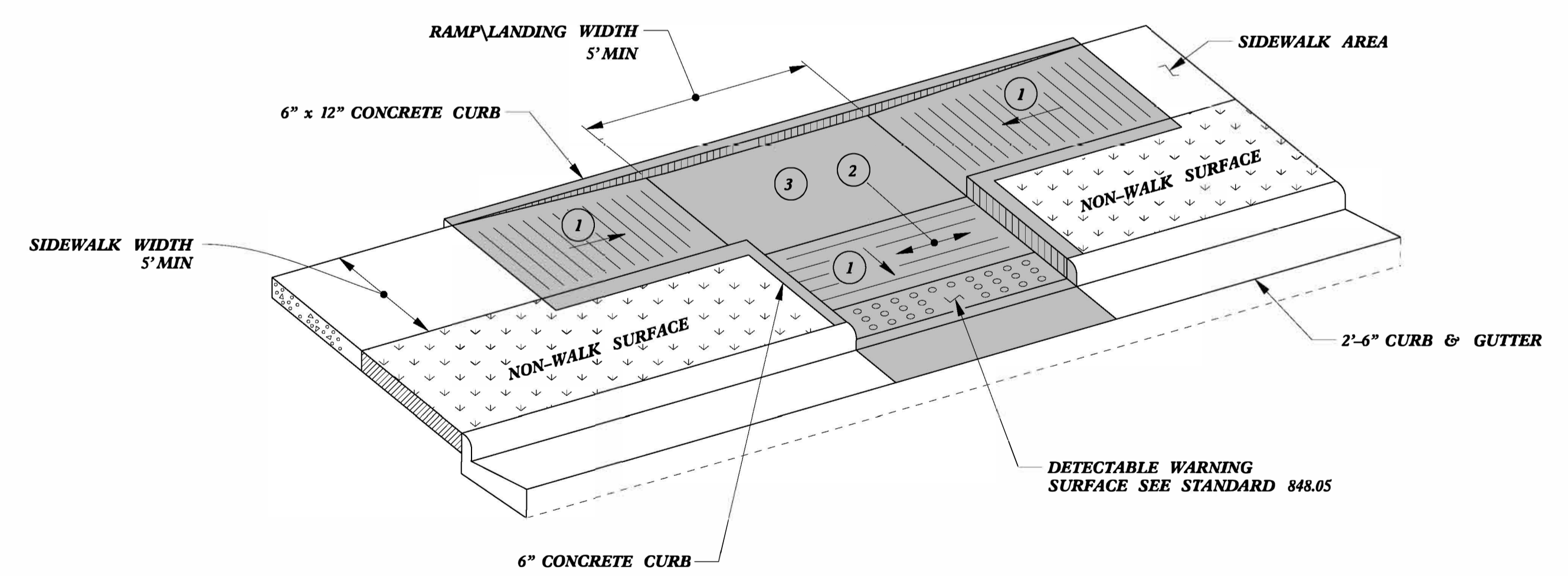

TYPE 3

- 1 8.33% (12:1) MAX RAMP SLOPE
- 2 CROSS SLOPE: 2.00%
- 3 CURB RAMPS REQUIRE A (4'-0") MINIMUM LANDING WITH A MAXIMUM CROSS SLOPE AND LONGITUDINAL SLOPE OF 2.00% WHERE PEDESTRIANS PERFORM TURNING MANEUVERS. SLOPE TO DRAIN TO CURB.

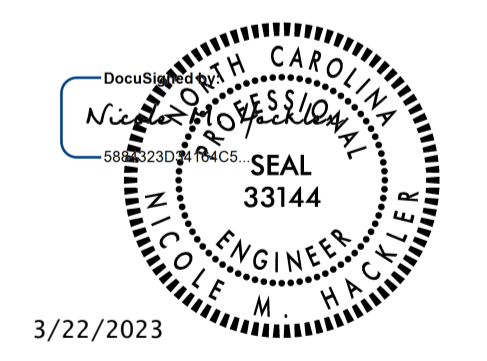

3/22/2023

DOCUMENT NOT CONSIDERED FINAL
UNLESS ALL SIGNATURES COMPLETED

CONTRACT STANDARDS AND DEVELOPMENT UNIT
Office 919-707-6950 FAX 919-250-4119

CURB RAMPS

ORIGINAL BY: J.S. HOWERTON DATE: 7/7/11
 MODIFIED BY: _____ DATE: _____
 CHECKED BY: _____ DATE: _____
 FILE SPEC. :stds/2012CurbRamp/CurbRampDetails.dgn

5/14/99

**PAY LIMITS FOR 2 OR 3 CURB RAMPS
(CALCULATE BASED ON NUMBER OF
SETS OF TRUNCATED DOMES)**

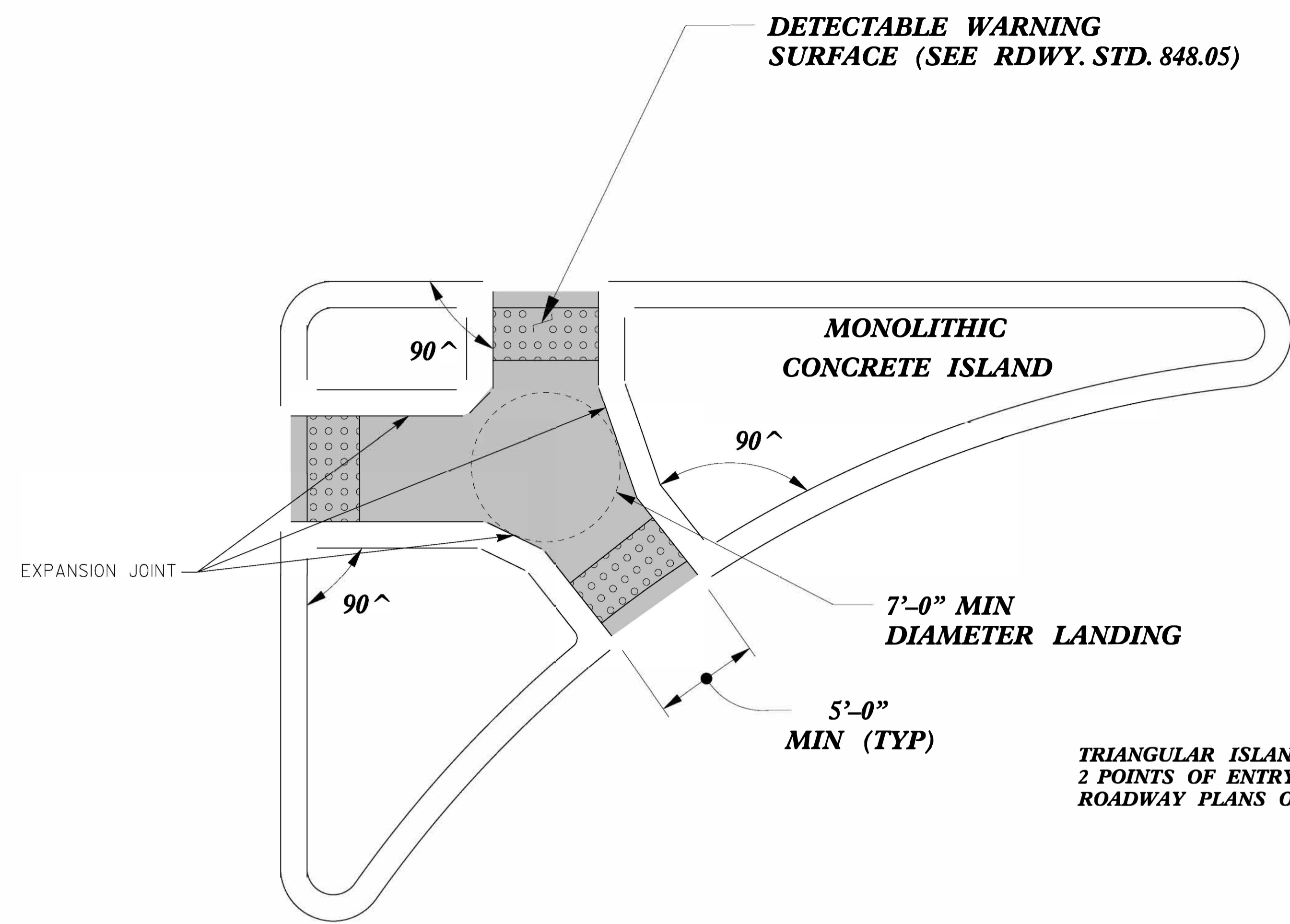

TRIANGULAR ISLANDS MAY BE CONSTRUCTED WITH ONLY 2 POINTS OF ENTRY AND EXIT AS SHOWN IN THE ROADWAY PLANS OR AS DIRECTED BY THE ENGINEER.

**TRIANGULAR ISLAND WITH CUT THROUGH
TYPE 6**

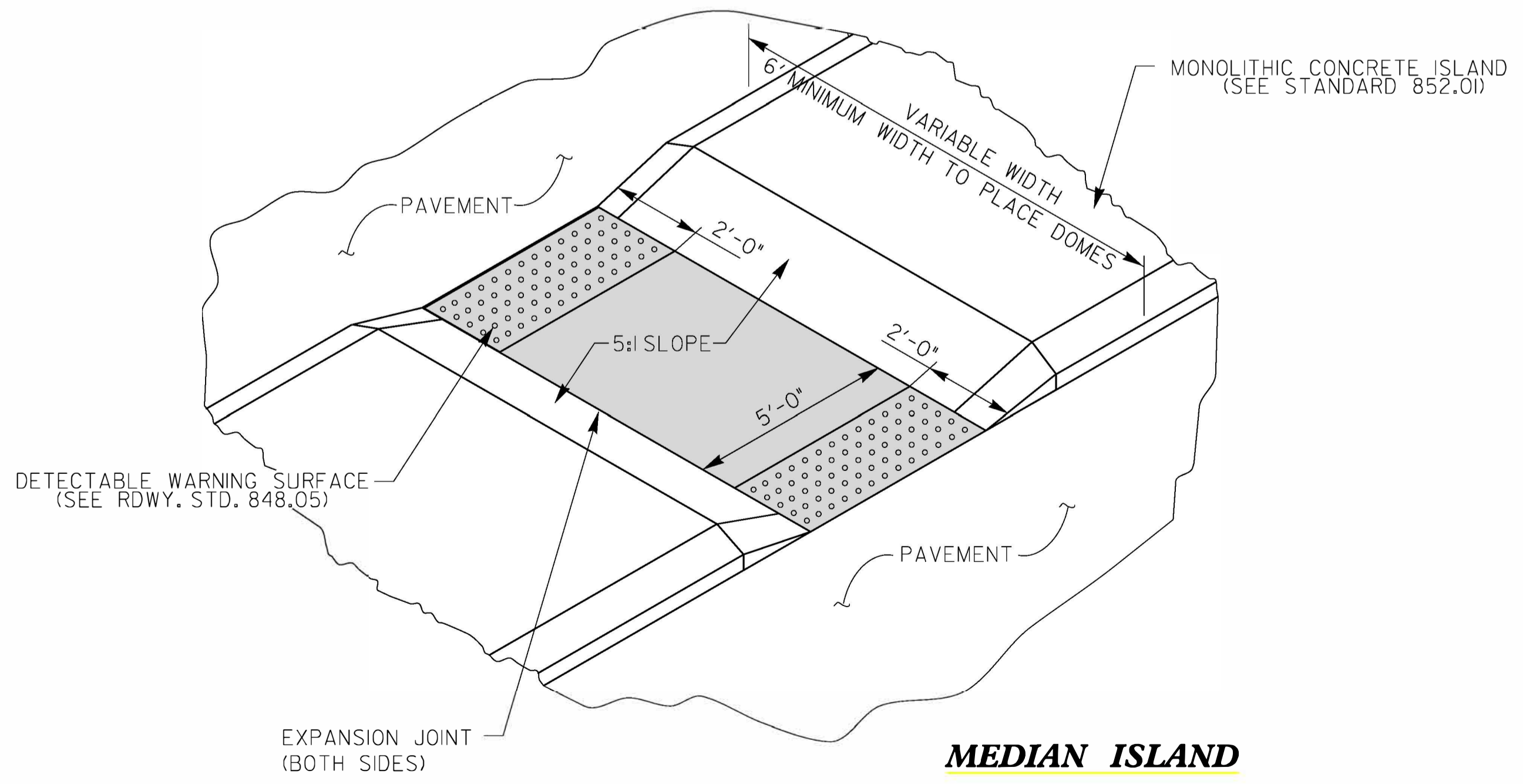

**MEDIAN ISLAND WITH CUT THROUGH
TYPE 7**

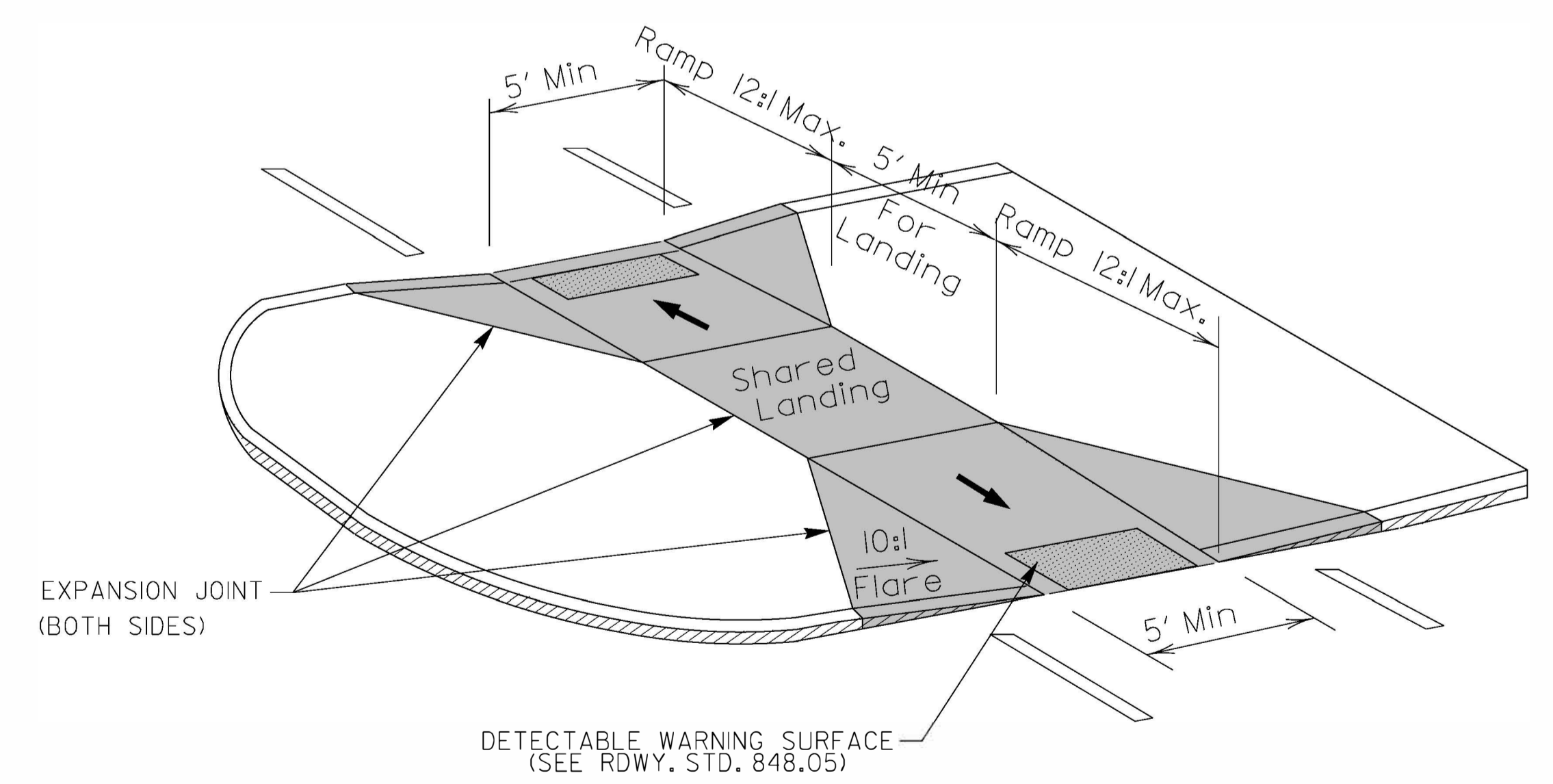

**MEDIAN ISLAND CURB RAMPS
TYPE 8**

DOCUMENT NOT CONSIDERED FINAL UNLESS ALL SIGNATURES COMPLETED

CONTRACT STANDARDS AND DEVELOPMENT UNIT
Office 919-707-6950 FAX 919-250-4119

CURB RAMPS
Median or Turn Lane Islands

ORIGINAL BY: J.S. HOWERTON DATE: 7/7/11
MODIFIED BY: DATE:
CHECKED BY: DATE:
FILE SPEC: stds/2012CurbRamp/CurbRampDetails.dgn

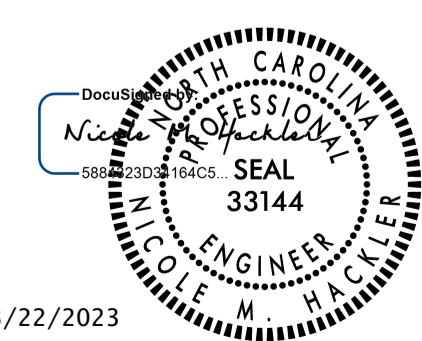

3/22/2023

5/14/99
SYTIME
CONSTRUCTION
SUGGESTIONS

8/17/99

NOTE: DUE TO THE PROPOSED SCOPE OF THIS PROJECT, THE PROPOSED DRAINAGE DESIGN DOES NOT MEET NCDOT HYDRAULICS DESIGN STANDARDS FOR PIPE CAPACITY AND SPREAD AT VARIOUS LOCATIONS.

PROJECT REFERENCE NO. U-6229		SHEET NO. 4	
ROADWAY DESIGN ENGINEER		HYDRAULICS ENGINEER	
DocuSigned by: Jerry Javellana		DocuSigned by: Brandon Barlean	
DOCUMENT NOT CONSIDERED FINAL UNLESS ALL SIGNATURES COMPLETED			

vhb VHB Engineering NC, P.C. (C-3705)
940 Main Campus Drive, Suite 500
Raleigh, NC 27606

BEGIN TIP PROJECT U-6229
-L- POT STA. 20+45.00

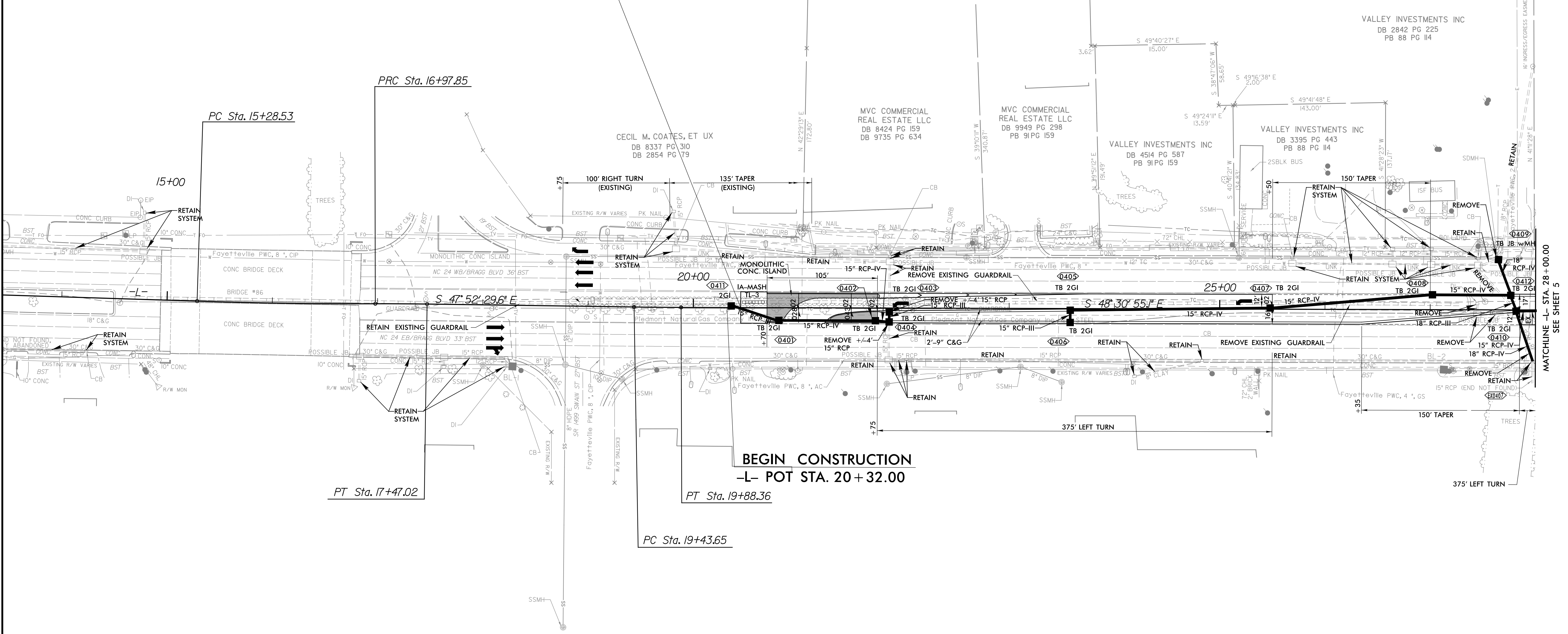

BEGIN CONSTRUCTION
-L- POT STA. 20+32.00

FOR CONCRETE ISLAND DETAIL SEE SHEET 2B-1

-L- CURVE DATA

PI Sta 16+13.20 $\Delta = 1^{\circ}56'25.0"$ (LT) $D = 1^{\circ}08'45.3"$ $L = 169.32'$ $T = 84.67'$ $R = 5,000.00'$ $SE = NA$	PI Sta 17+22.44 $\Delta = 0^{\circ}56'20.6"$ (RT) $D = 1^{\circ}54'35.5"$ $L = 49.17'$ $T = 24.58'$ $R = 3,000.00'$ $SE = NA$	PI Sta 19+66.01 $\Delta = 0^{\circ}38'25.5"$ (LT) $D = 1^{\circ}25'56.6"$ $L = 44.71'$ $T = 22.36'$ $R = 4,000.00'$ $SE = NA$
--	---	---

1/9/2023
U6229_rdy_pah04.dgn
-sawant

MATCHLINE -L- STA. 28+00.00
SEE SHEET 5

8/17/99

NOTE: DUE TO THE PROPOSED SCOPE OF THIS PROJECT, THE PROPOSED DRAINAGE DESIGN DOES NOT MEET NCDOT HYDRAULICS DESIGN STANDARDS FOR PIPE CAPACITY AND SPREAD AT VARIOUS LOCATIONS.

PROJECT REFERENCE NO. U-6229		SHEET NO. 5	
ROADWAY DESIGN ENGINEER		HYDRAULICS ENGINEER	
Designed by: Jerry Savillana		DocuSigned by: Brandon Barlow	
DOCUMENT NOT CONSIDERED FINAL UNLESS ALL SIGNATURES COMPLETED			

vhb VHB Engineering NC, P.C. (C-3705)
940 Main Campus Drive, Suite 500
Raleigh, NC 27605

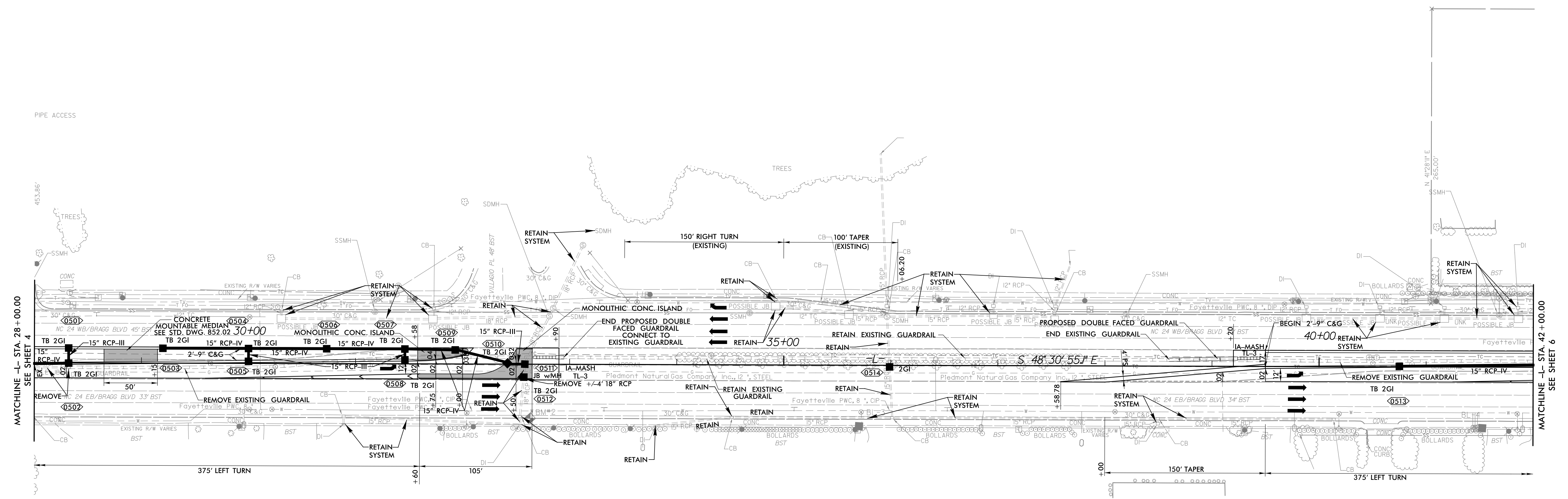
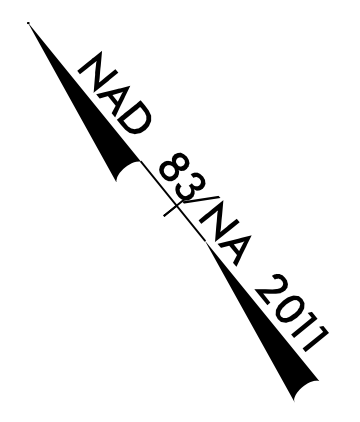

FOR CONCRETE ISLAND DETAIL SEE SHEET 2B-1

1/9/2023
U6229_rdy_psh05.dgn
sargent

8/17/99

NOTE: DUE TO THE PROPOSED SCOPE OF THIS PROJECT, THE PROPOSED DRAINAGE DESIGN DOES NOT MEET NCDOT HYDRAULICS DESIGN STANDARDS FOR PIPE CAPACITY AND SPREAD AT VARIOUS LOCATIONS.

PROJECT REFERENCE NO. U-6229		SHEET NO. 6	
RW SHEET NO.		HYDRAULICS ENGINEER	
ROADWAY DESIGN ENGINEER		HYDRAULICS ENGINEER	
DocuSigned by: Jerry Javellana		DocuSigned by: Brandon Barlow	
DOCUMENT NOT CONSIDERED FINAL UNLESS ALL SIGNATURES COMPLETED			

vhb VHB Engineering NC, P.C. (C-3705)
940 Main Campus Drive, Suite 500
Raleigh, NC 27606

AGREE STORES LLC
DB 10615 PG 60
PB 104 PG 77

R & W PIZZA HUTS OF NC
DB 3892 PG 785
PB 81 PG 30

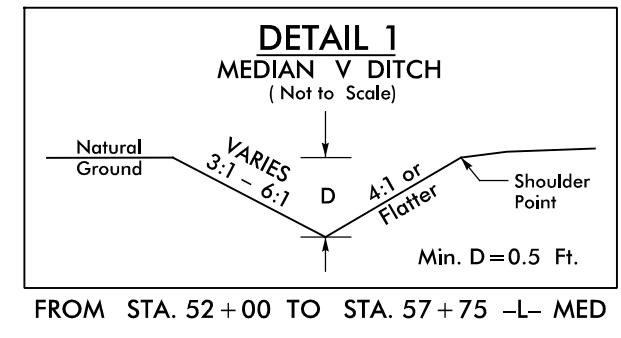
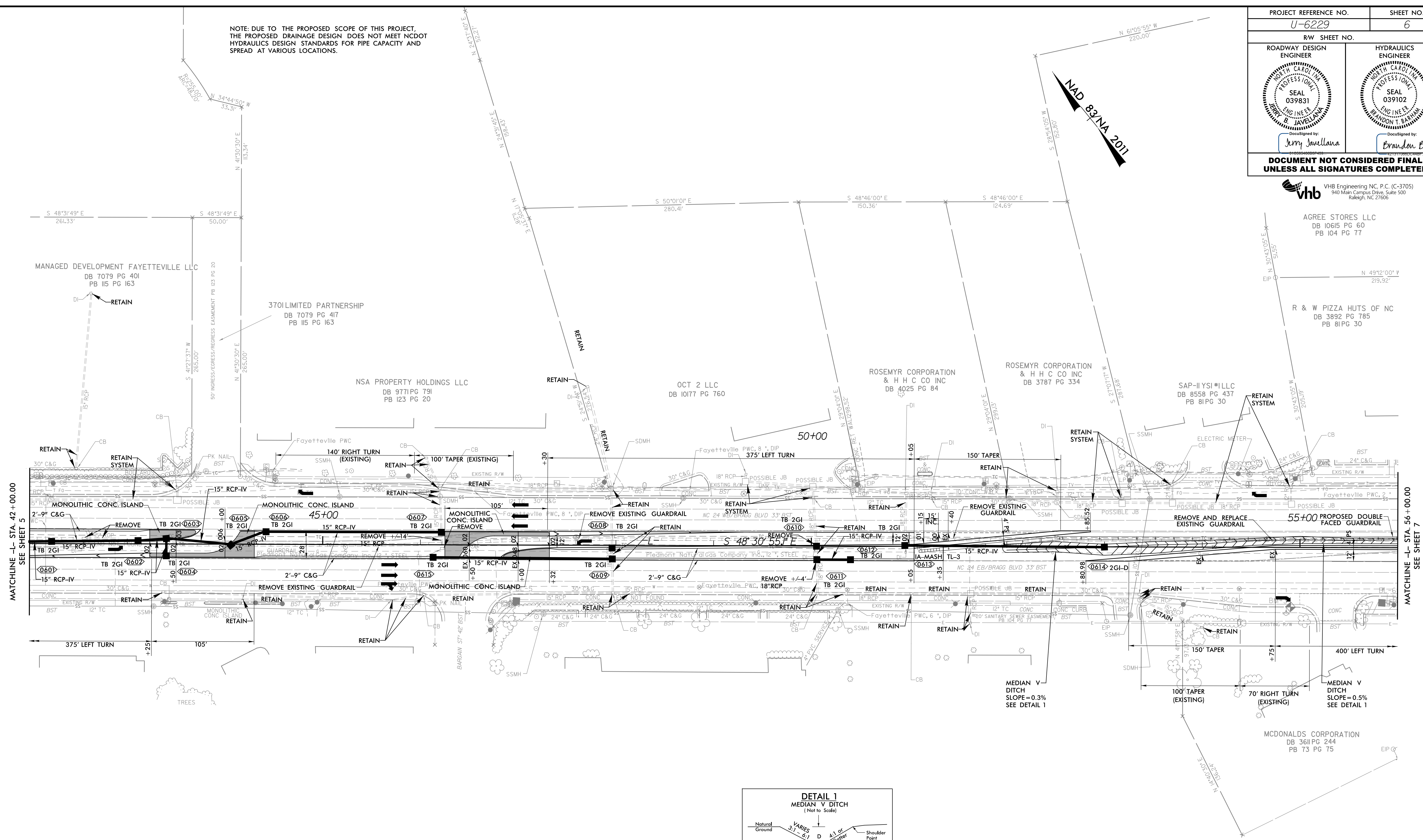

MCDONALDS CORPORATION
DB 361 PG 244
PB 73 PG 75



FOR CONCRETE ISLAND DETAIL SEE SHEET 2B-1

1/9/2023
U6229_rdy_pah06.dgn
-sawant

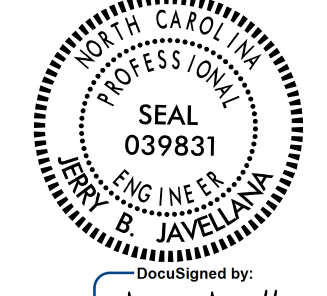
8/17/99



PROJECT REFERENCE NO. U-6229		SHEET NO. 7	
RW SHEET NO.			
ROADWAY DESIGN ENGINEER		HYDRAULICS ENGINEER	
 Jerry Javellana Deceased by:		 Brandon Carlson Deceased by:	
DOCUMENT NOT CONSIDERED FINAL UNLESS ALL SIGNATURES COMPLETED			

vhb VHB Engineering Inc., P.C. (C-3705)
 940 Main Campus Drive, Suite 500
 Raleigh, NC 27606

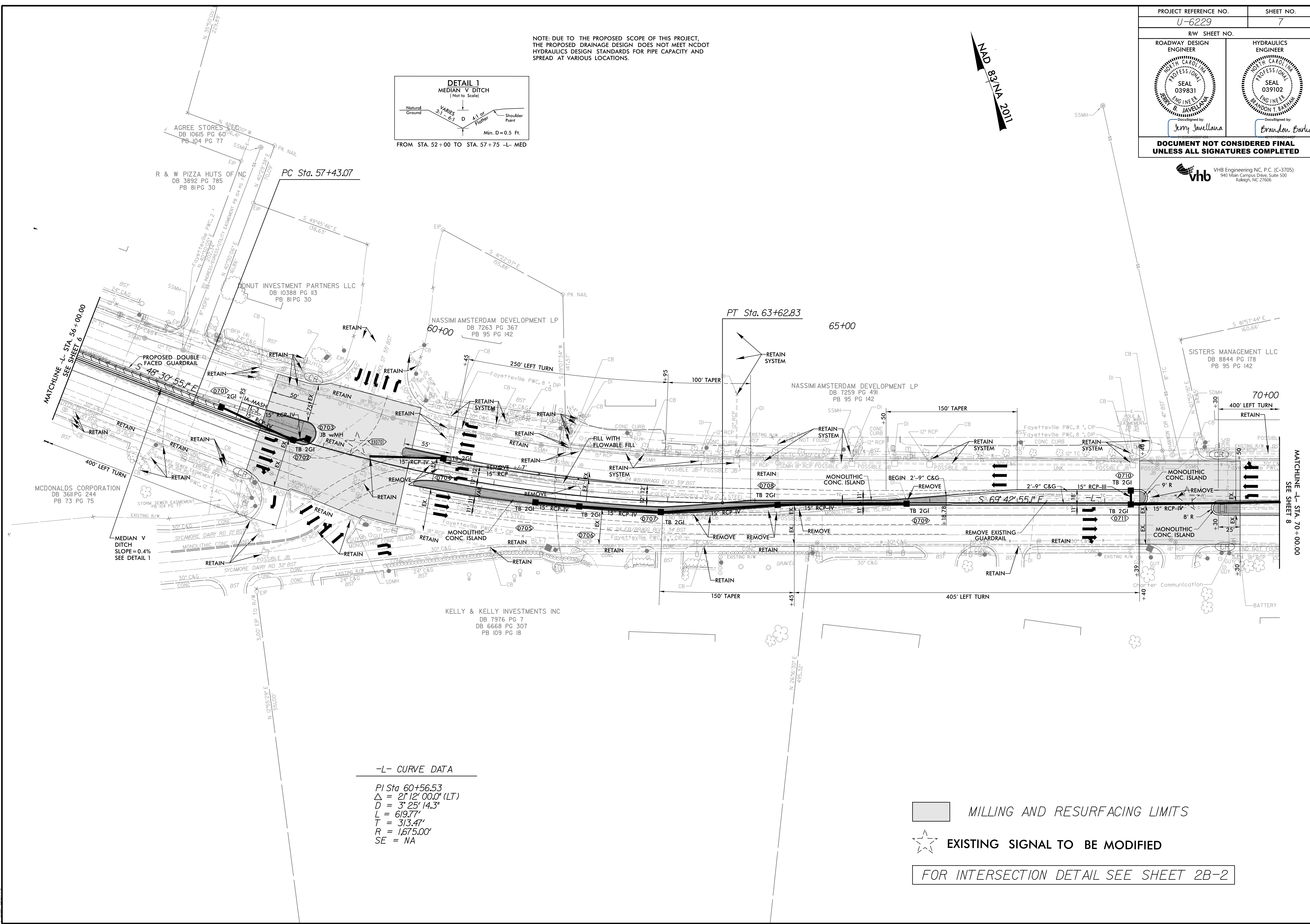
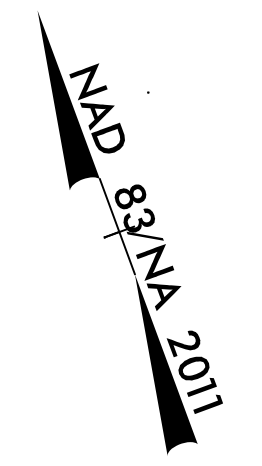
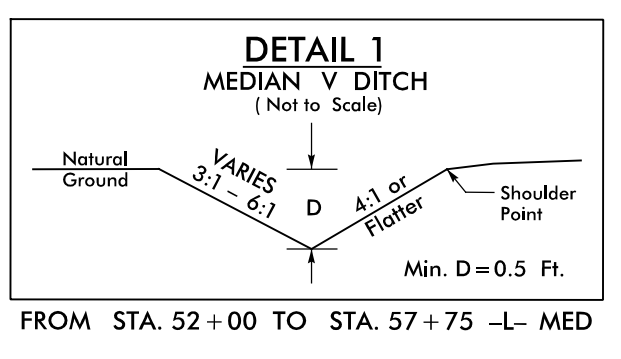
NOTE: DUE TO THE PROPOSED SCOPE OF THIS PROJECT, THE PROPOSED DRAINAGE DESIGN DOES NOT MEET NCDOT HYDRAULICS DESIGN STANDARDS FOR PIPE CAPACITY AND SPREAD AT VARIOUS LOCATIONS.



-L- CURVE DATA
 PI Sta 60+56.53
 $\Delta = 21^\circ 12' 00.0''$ (LT)
 $D = 3^\circ 25' 14.3''$
 $L = 619.77'$
 $T = 313.47'$
 $R = 1,675.00'$
 SE = NA

 MILLING AND RESURFACING LIMITS
 EXISTING SIGNAL TO BE MODIFIED
 FOR INTERSECTION DETAIL SEE SHEET 2B-2

1/9/2023
 U6229_rdy_pah07.dgn
 sapient

PROJECT REFERENCE NO. U-6229		SHEET NO. 8	
RW SHEET NO.			
ROADWAY DESIGN ENGINEER		HYDRAULICS ENGINEER	
DocuSigned by: Jerry Javellana		DocuSigned by: Brandon Barham	
DOCUMENT NOT CONSIDERED FINAL UNLESS ALL SIGNATURES COMPLETED			

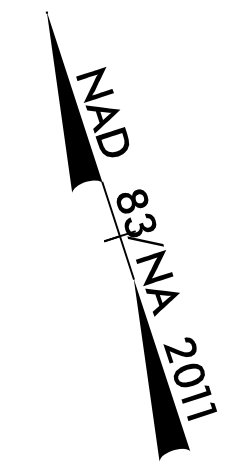

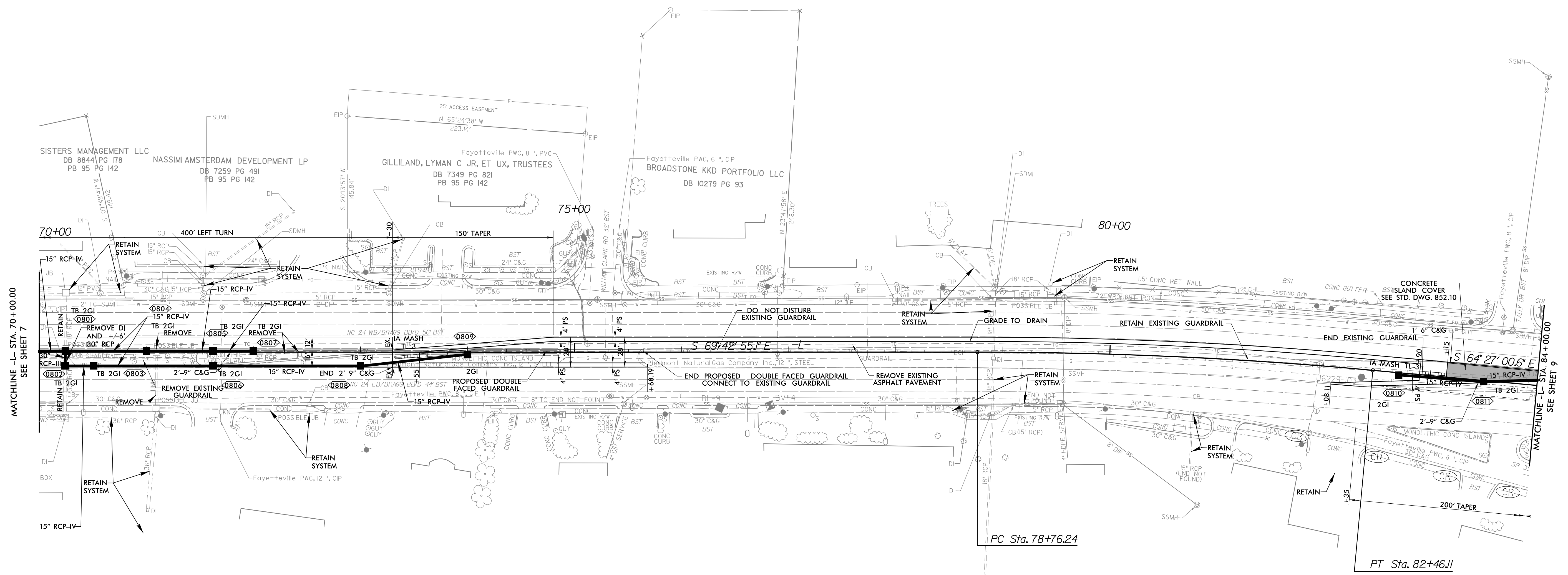

NOTE: DUE TO THE PROPOSED SCOPE OF THIS PROJECT, THE PROPOSED DRAINAGE DESIGN DOES NOT MEET NCDOT HYDRAULICS DESIGN STANDARDS FOR PIPE CAPACITY AND SPREAD AT VARIOUS LOCATIONS.



-L- CURVE DATA

PI Sta 80+61.31
 $\Delta = 5'15'' 54.6'' (RT)$
 $D = 1'25'' 24.6''$
 $L = 369.87'$
 $T = 185.07'$
 $R = 4,025.00'$
 $SE = NA$

PROJECT REFERENCE NO. U-6229		SHEET NO. 9	
ROADWAY DESIGN ENGINEER		HYDRAULICS ENGINEER	
 Jerry Javellana		 Brandon Barham	
DOCUMENT NOT CONSIDERED FINAL UNLESS ALL SIGNATURES COMPLETED			

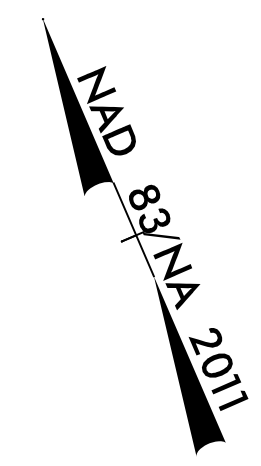

NOTE: DUE TO THE PROPOSED SCOPE OF THIS PROJECT, THE PROPOSED DRAINAGE DESIGN DOES NOT MEET NCDOT HYDRAULICS DESIGN STANDARDS FOR PIPE CAPACITY AND SPREAD AT VARIOUS LOCATIONS.

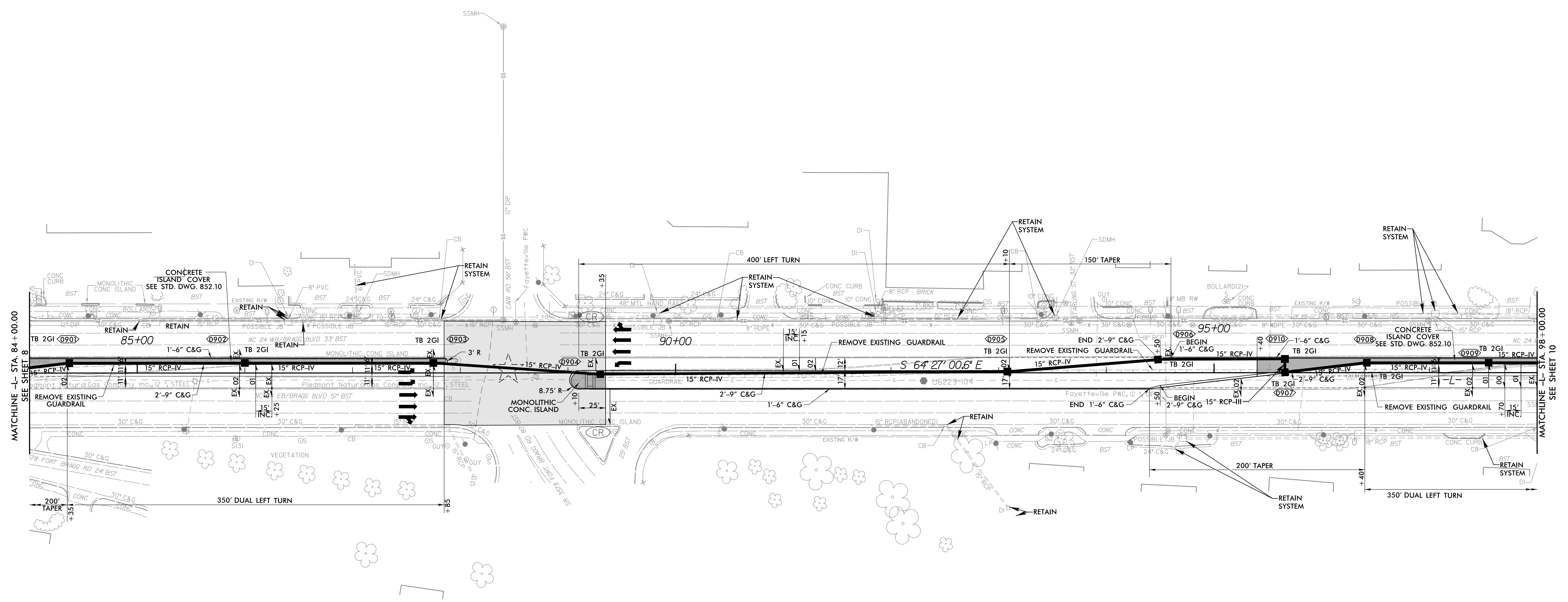

MATCHLINE - STA. 84+00.00
SEE SHEET 8

MATCHLINE - STA. 98+00.00
SEE SHEET 10

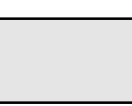
-  EXISTING SIGNAL TO BE MODIFIED
-  MILLING AND RESURFACING LIMITS

8/17/99

NOTE: DUE TO THE PROPOSED SCOPE OF THIS PROJECT THE PROPOSED DRAINAGE DESIGN DOES NOT MEET NCDOT HYDRAULICS DESIGN STANDARDS FOR PIPE CAPACITY AND SPREAD AT VARIOUS LOCATIONS.

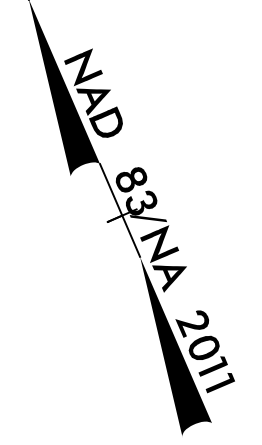

PROJECT REFERENCE NO. U-6229	SHEET NO. 10
RW SHEET NO.	
ROADWAY DESIGN ENGINEER JERRY JAVELLANA NORTH CAROLINA PROFESSIONAL SEAL 039831	HYDRAULICS ENGINEER BRANDEN BARLAN NORTH CAROLINA PROFESSIONAL SEAL 039102
<p>DOCUMENT NOT CONSIDERED FINAL UNLESS ALL SIGNATURES COMPLETED</p>	

vhb VHB Engineering NC, P.C. (C-3705) 940 Main Campus Drive, Suite 500 Raleigh, NC 27606

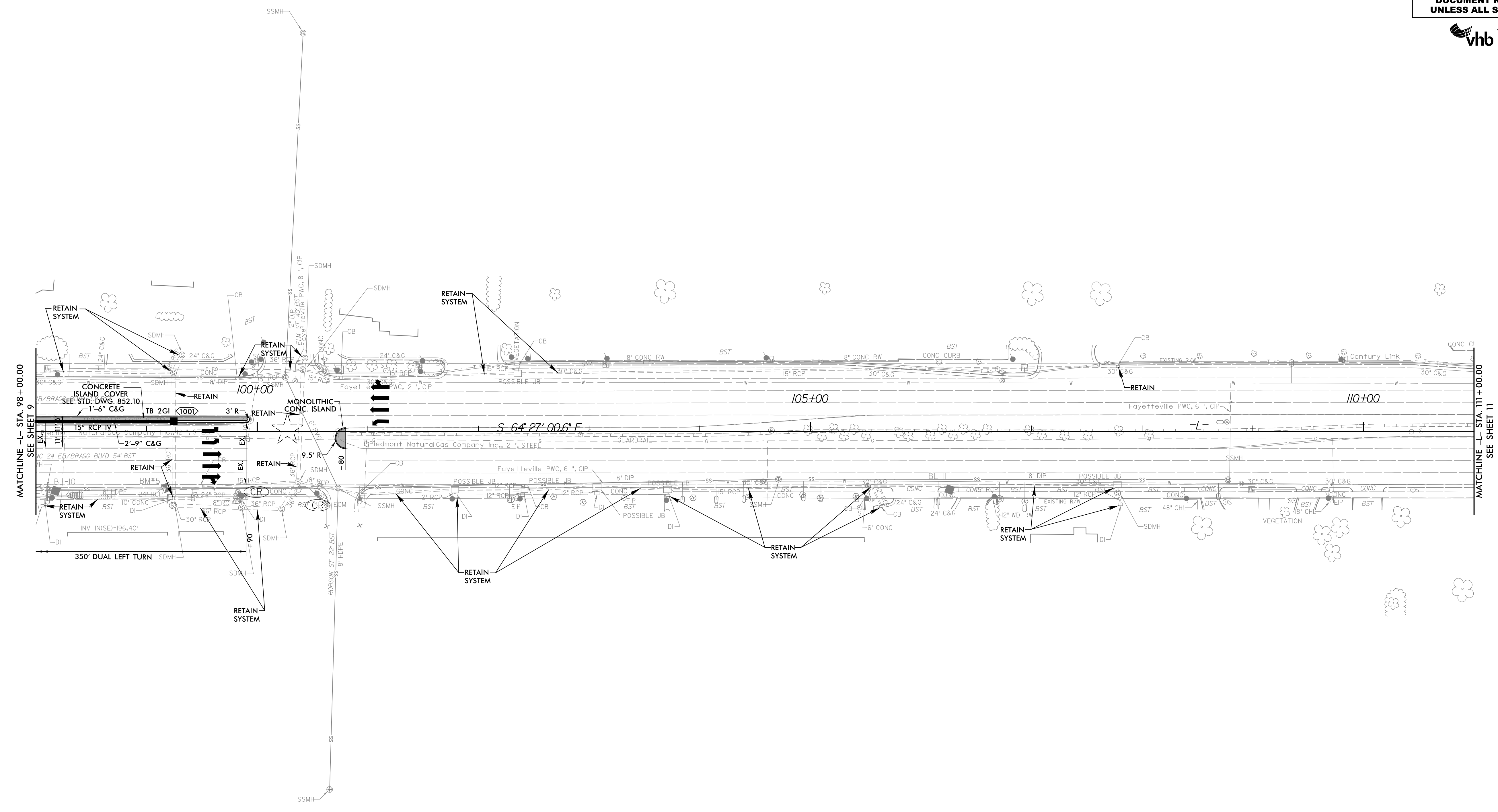

★ EXISTING SIGNAL TO BE MODIFIED

1/9/2023 U6229_rdy_pah10.dgn sapient

NOTE: DUE TO THE PROPOSED SCOPE OF THIS PROJECT, THE PROPOSED DRAINAGE DESIGN DOES NOT MEET NCDOT HYDRAULICS DESIGN STANDARDS FOR PIPE CAPACITY AND SPREAD AT VARIOUS LOCATIONS.

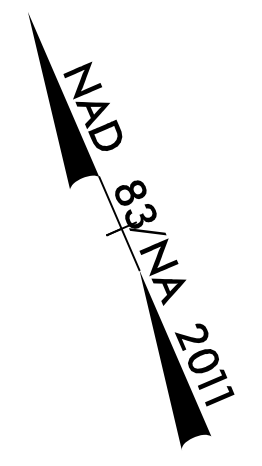

PROJECT REFERENCE NO. U-6229	SHEET NO. 11
RW SHEET NO.	
ROADWAY DESIGN ENGINEER 	HYDRAULICS ENGINEER
Designed by: Jerry Javelana	Designed by: Brandon Barlow
DOCUMENT NOT CONSIDERED FINAL UNLESS ALL SIGNATURES COMPLETED	

vhb VHB Engineering NC, P.C. (C-3705)
940 Main Campus Drive, Suite 500
Raleigh, NC 27606

END TIP PROJECT U-6229 -L- POT STA. 112 + 08.29

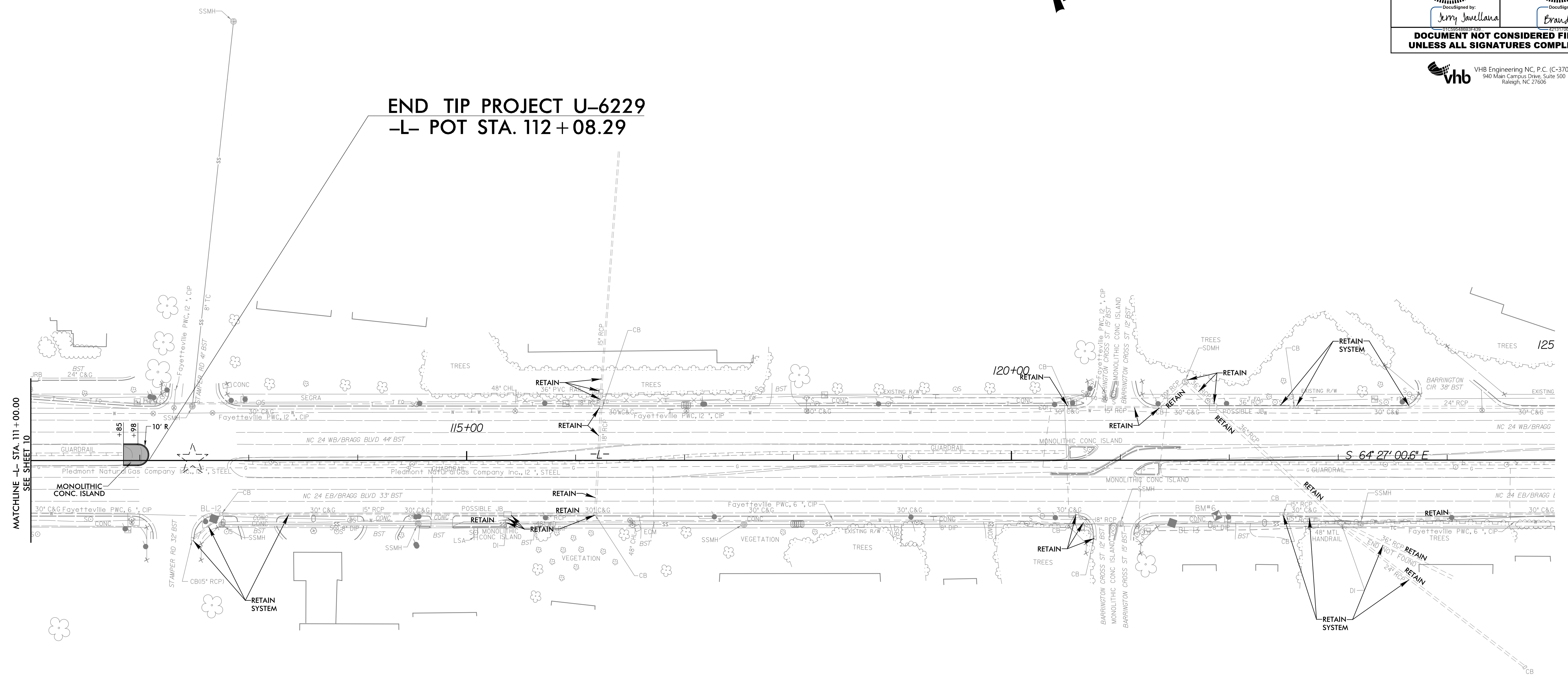

MATCHLINE -L- STA. 111 + 00.00
SEE SHEET 10

EXISTING SIGNAL TO BE MODIFIED