

PLAN OF CONCRETE BARRIER RAIL

NOTES

THE BARRIER RAIL IN EACH CONTINUOUS UNIT SPAN SHALL NOT BE CAST UNTIL ALL SLAB CONCRETE IN THAT SPAN HAS BEEN CAST AND HAS REACHED A MINIMUM COMPRESSIVE STRENGTH OF 3,000 PSI.

WHEN FOAM JOINT SEAL IS REQUIRED, THE JOINT IN THE DECK SHALL BE SAWED PRIOR TO THE CASTING OF BARRIER RAIL.

ALL REINFORCING STEEL IN BARRIER RAILS SHALL BE EPOXY COATED.

THE #5 S3, S4, S5 AND S6 BARS SHALL BE INSTALLED, USING AN ADHESIVE ANCHORING SYSTEM, AFTER SAWING THE JOINT. THE YIELD LOAD FOR THE #5 S3, S4, S5 AND S6 BARS IS 18.6 KIPS. FIELD TESTING FOR THE ADHESIVE BONDING SYSTEM IS NOT REQUIRED.

GROOVED CONTRACTION JOINTS, 1/2" IN DEPTH, SHALL BE TOOLED IN ALL EXPOSED FACES OF THE BARRIER RAIL AND IN ACCORDANCE WITH ARTICLE 825-10(B) OF THE STANDARD SPECIFICATIONS. THE CONTRACTION JOINT SHALL BE LOCATED AT EACH THIRD POINT BETWEEN BARRIER RAIL EXPANSION JOINTS. ONLY ONE CONTRACTION JOINT IS REQUIRED AT MIDPOINT OF BARRIER RAIL SEGMENTS LESS THAN 20 FEET IN LENGTH AND NO CONTRACTION JOINTS ARE REQUIRED FOR THOSE SEGMENTS LESS THAN 10 FEET IN LENGTH.

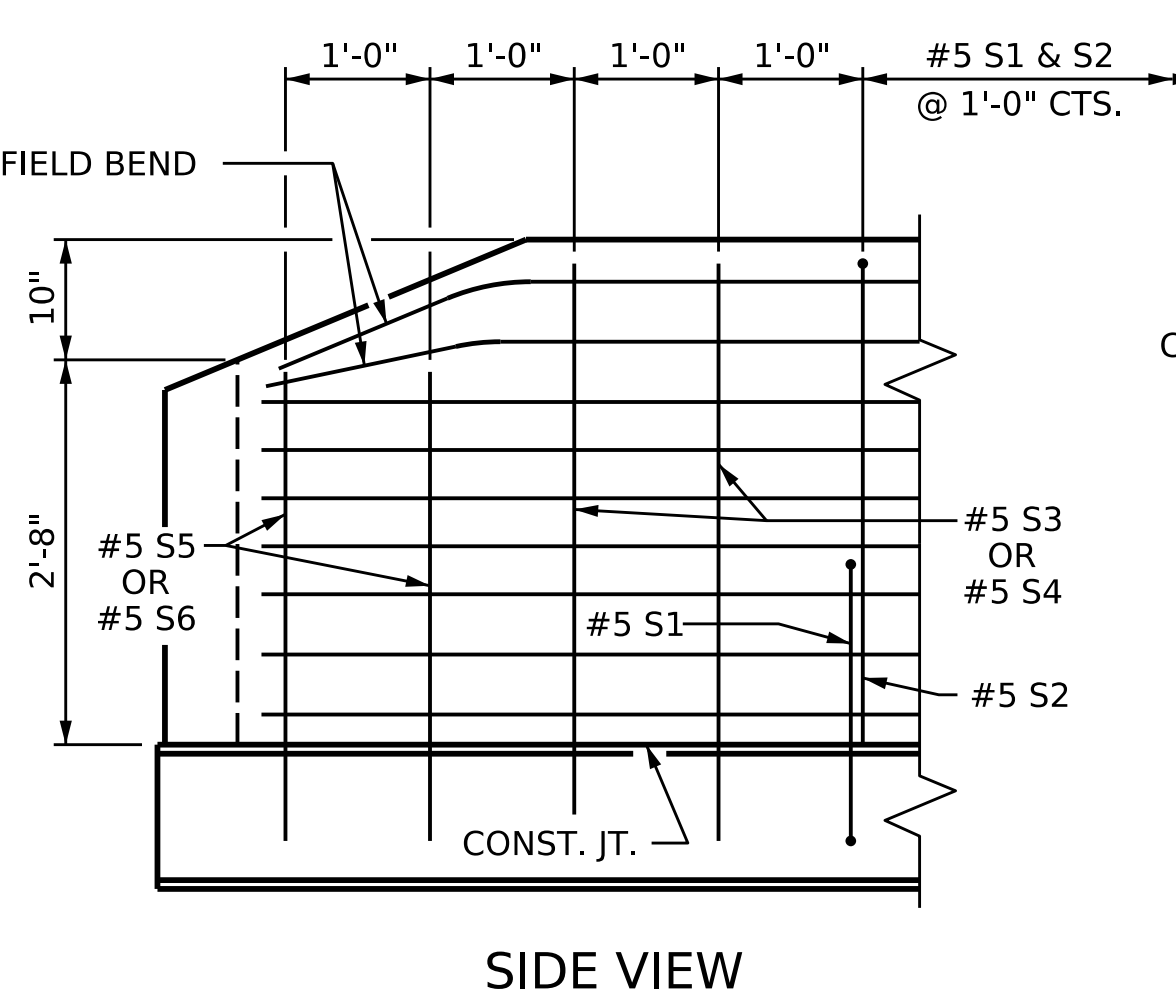
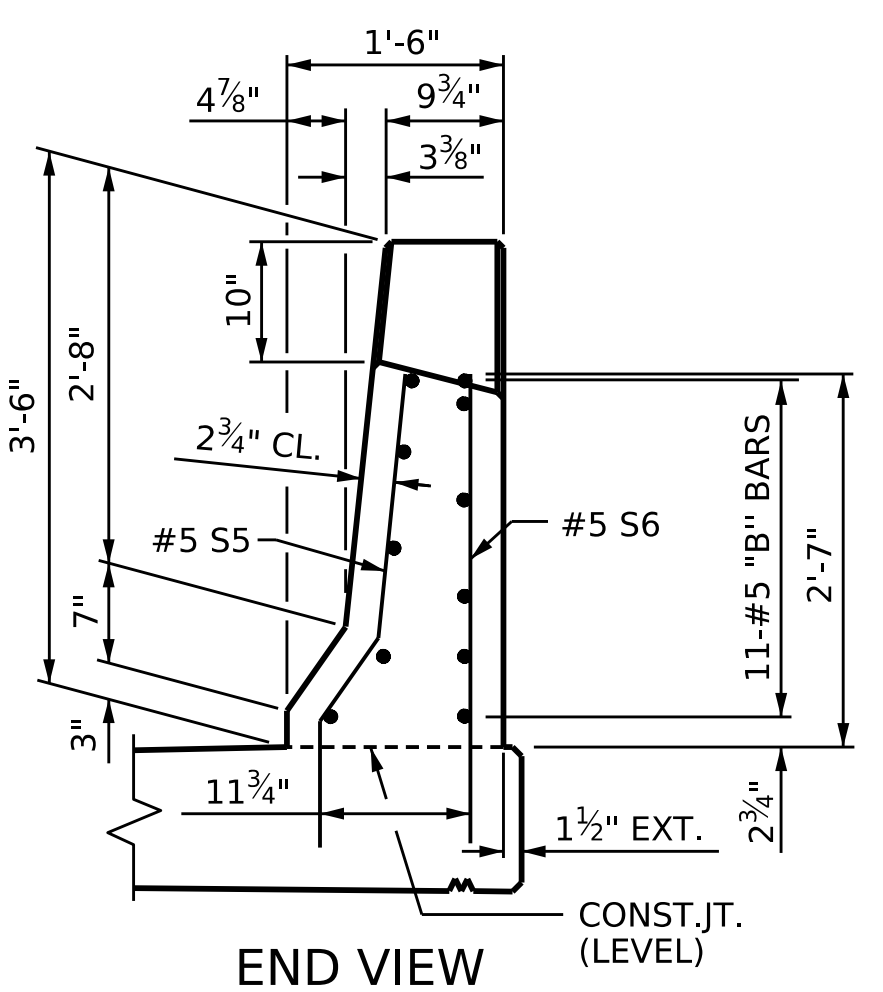
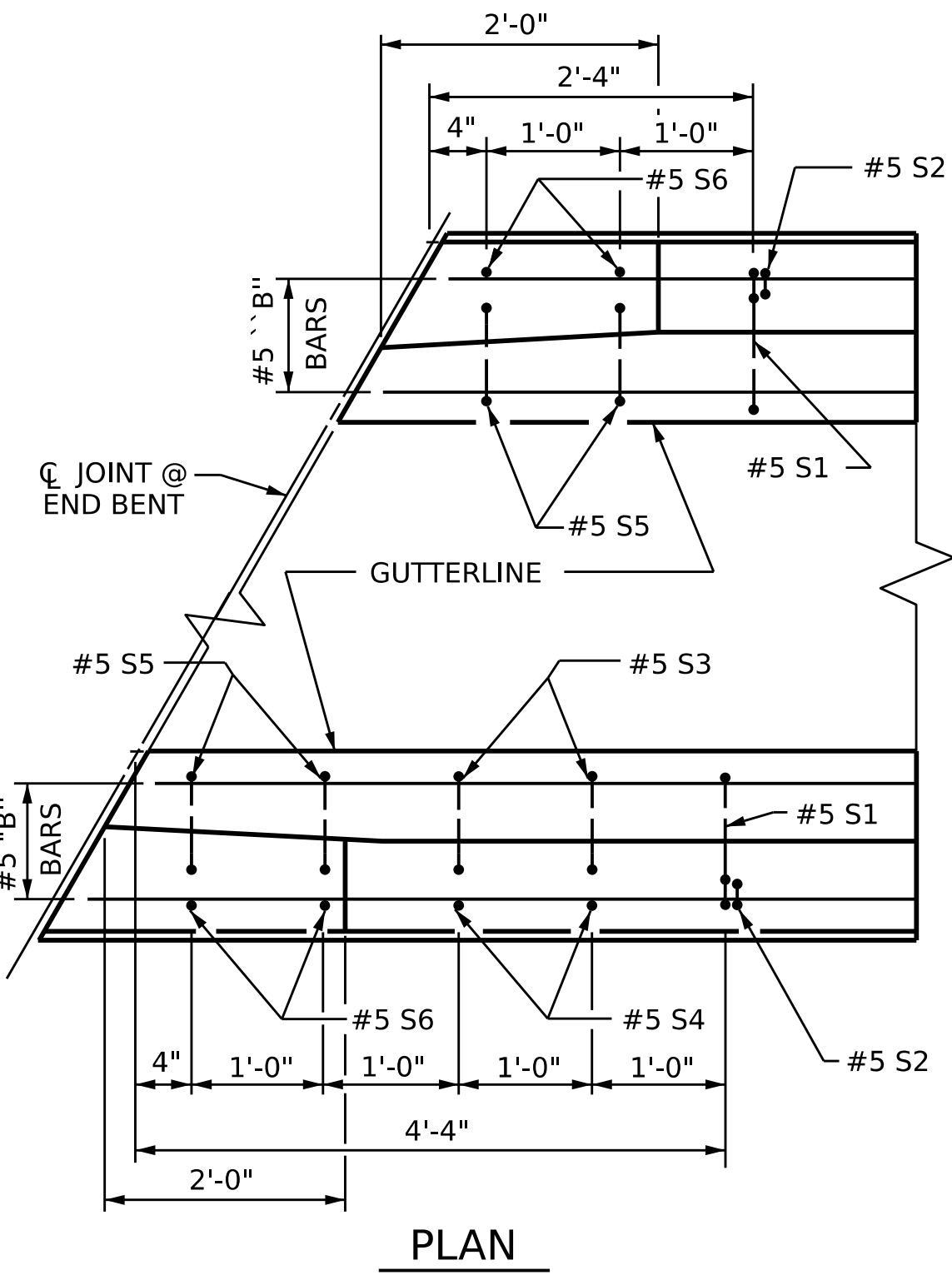

END OF RAIL DETAILS
FOR ADHESIVE ANCHORING AT SAWED JOINTS

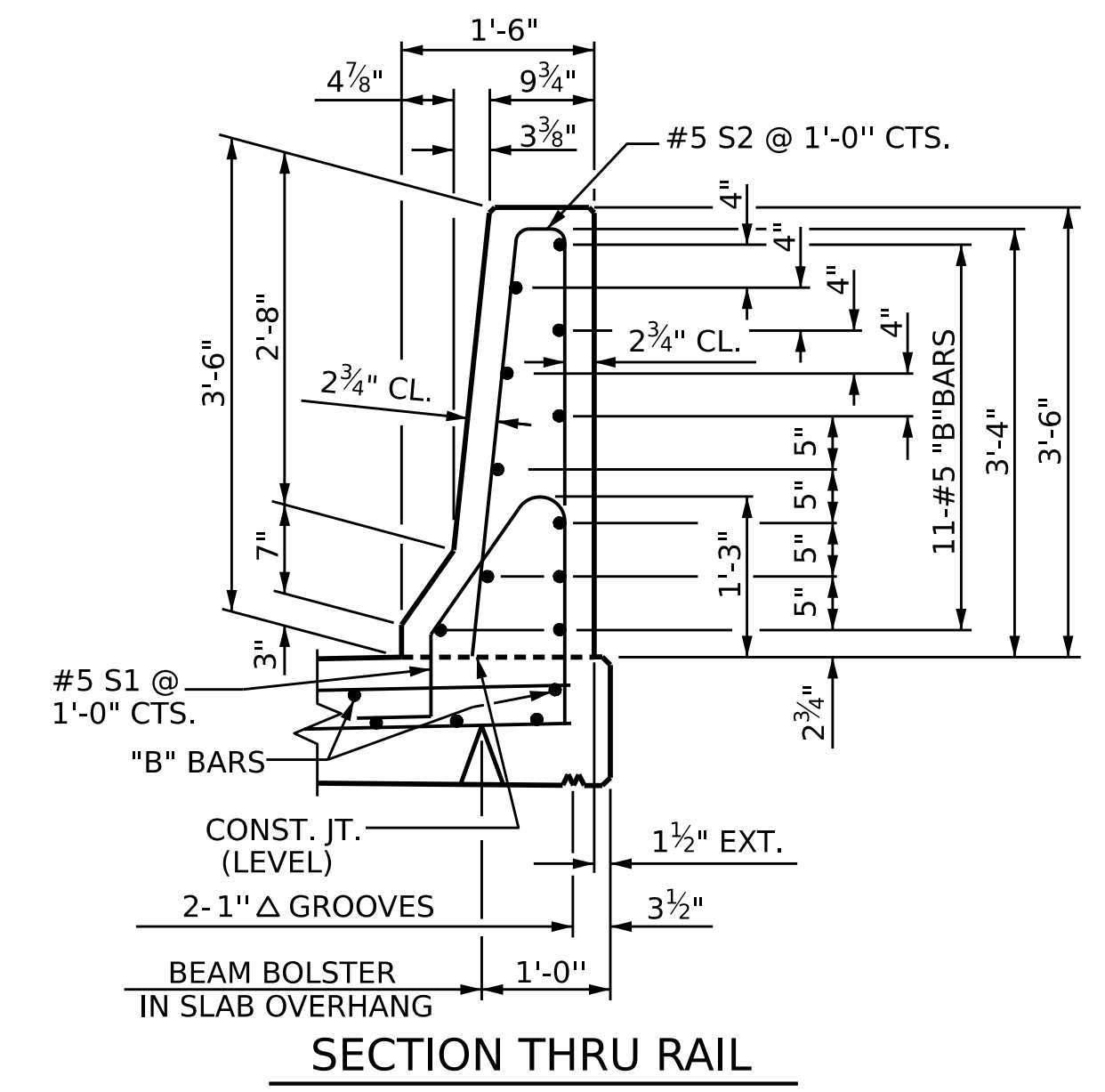

SECTION THRU RAIL

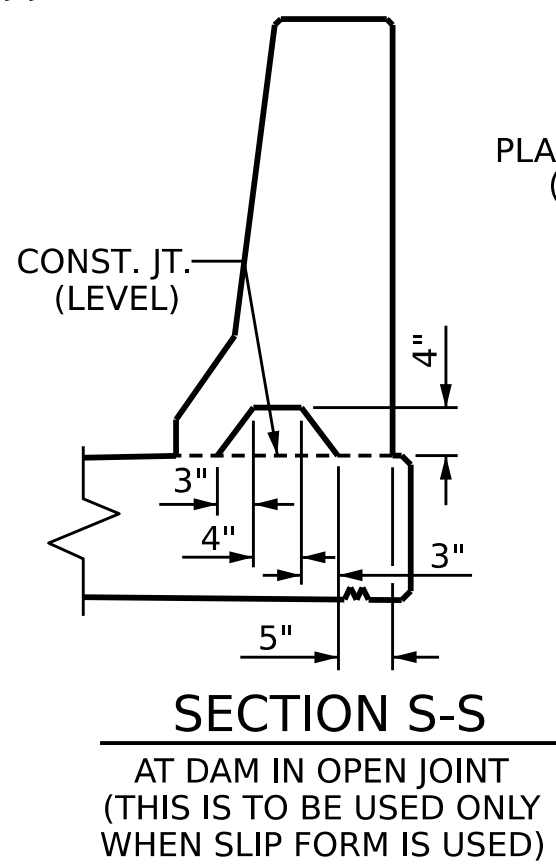

ELEVATION AT EXPANSION JOINTS

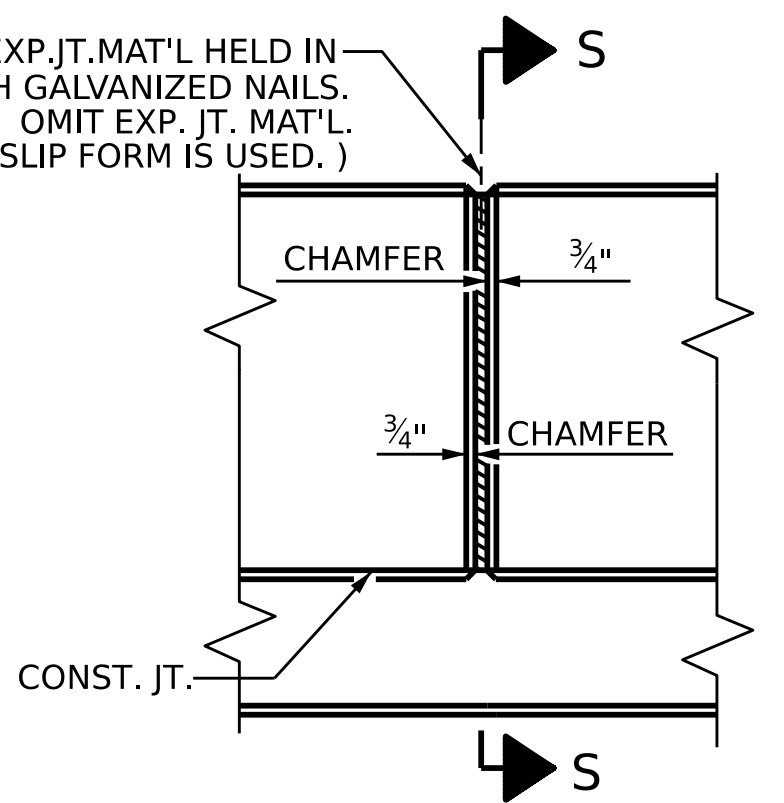

BARRIER RAIL DETAILS

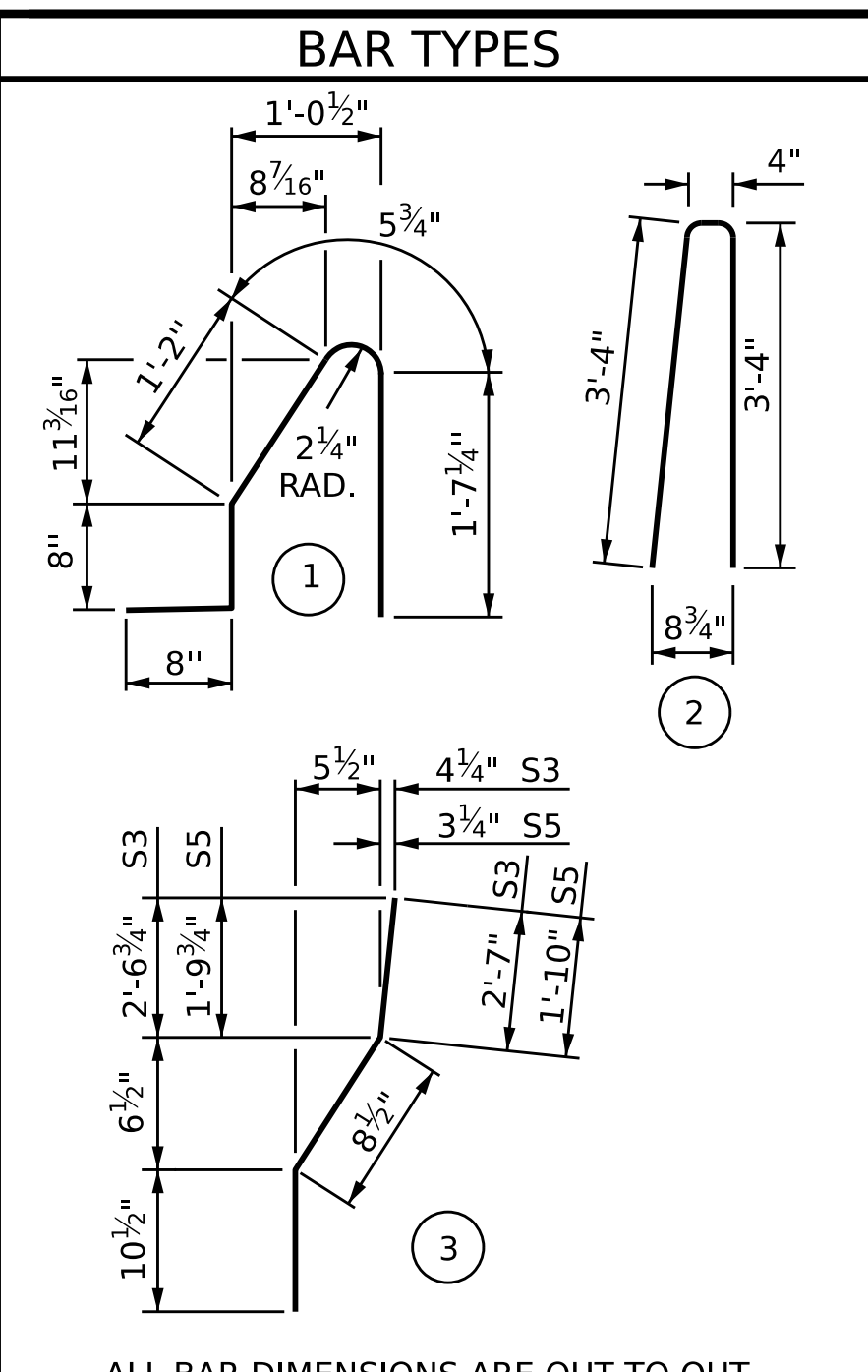

ALL BAR DIMENSIONS ARE OUT TO OUT

BILL OF MATERIAL
FOR CONCRETE BARRIER RAIL ONLY

BAR	NO.	SIZE	TYPE	LENGTH	WEIGHT
* B1	44	#5	STR	15'-6"	711
* B2	44	#5	STR	9'-1"	417
* B3	198	#5	STR	24'-8"	5094
* S1	524	#5	1	4'-7"	2505
* S2	524	#5	2	7'-0"	3826
* S3	4	#5	3	4'-2"	17
* S4	4	#5	STR	4'-0"	17
* S5	8	#5	3	3'-5"	29
* S6	8	#5	STR	3'-3"	27

* EPOXY COATED REINFORCING STEEL	12,643	LBS.
CLASS AA CONCRETE	72.9	CU. YDS.
CONCRETE BARRIER RAIL	535.68	LIN. FT.

PROJECT NO. B-5721
ROCKINGHAM COUNTY
 STATION: 21+64.00 -L-

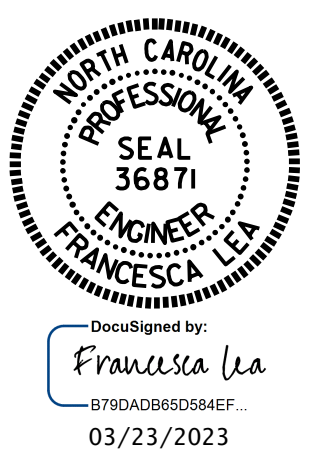

STATE OF NORTH CAROLINA
 DEPARTMENT OF TRANSPORTATION
 RALEIGH

**STANDARD
 CONCRETE
 BARRIER RAIL**

ASSEMBLED BY: Q. T. NGUYEN	DATE: 07/2022
CHECKED BY: F. LEA	DATE: 12/2022
DRAWN BY: ARB 5/87	MAA/GM
CHECKED BY: SJD 9/87	REV. 6/13 MAA/GM
	REV. 12/17 MAA/THC

REVISIONS						SHEET NO. S-18
NO.	BY:	DATE:	NO.	BY:	DATE:	
1			3			TOTAL SHEETS 31
2			4			

DOCUMENT NOT CONSIDERED FINAL UNLESS ALL SIGNATURES COMPLETED