

EXISTING JOINT AT END BENT

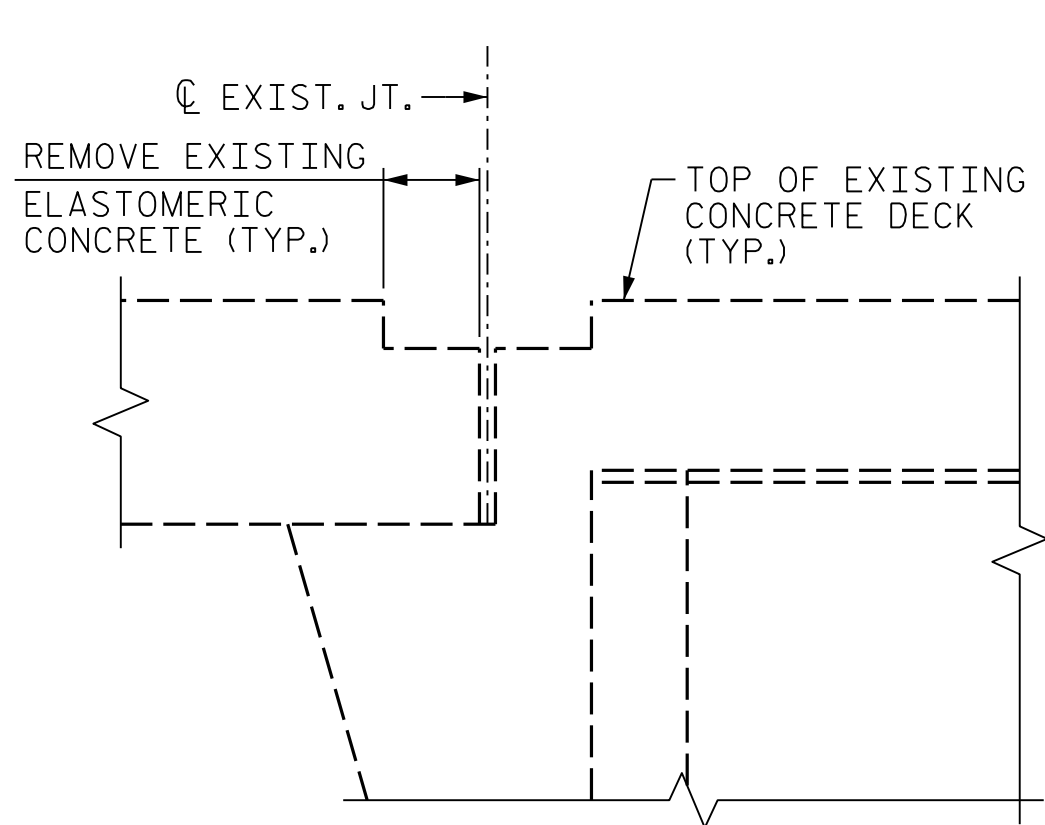

MINIMUM EXISTING JOINT DEMOLITION AT END BENT

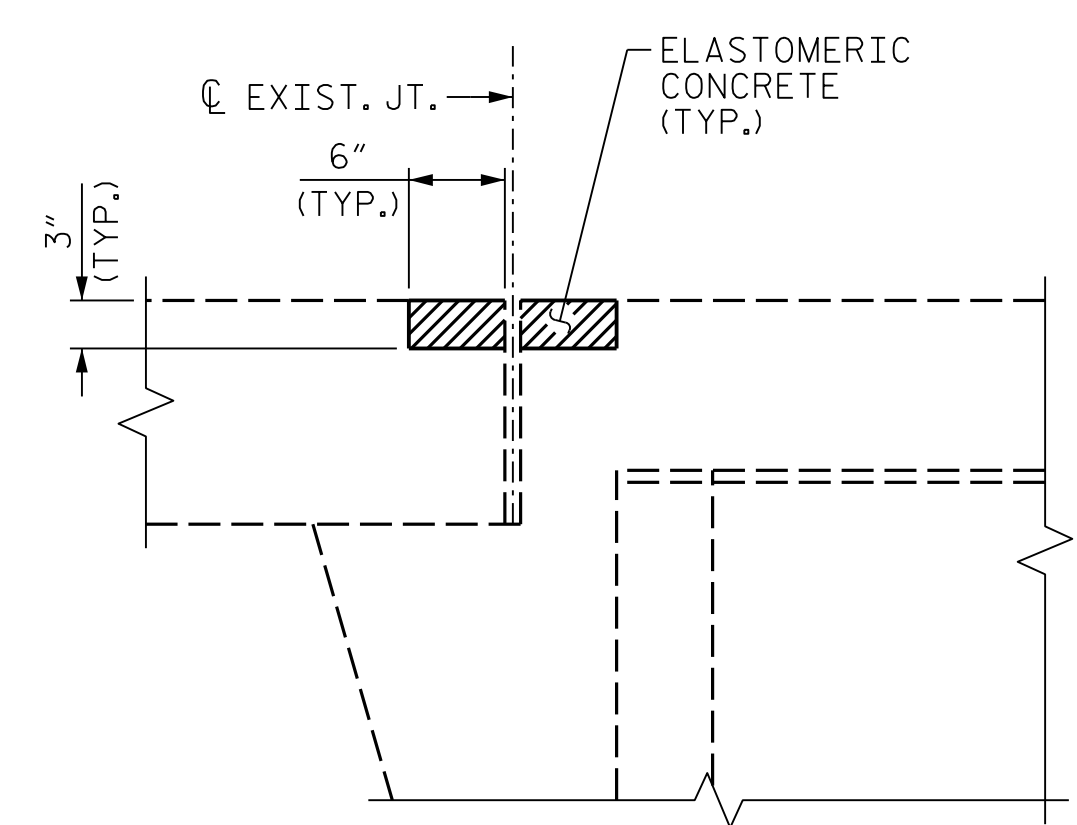

PROPOSED JOINT PRE-SAWED DIMENSIONS

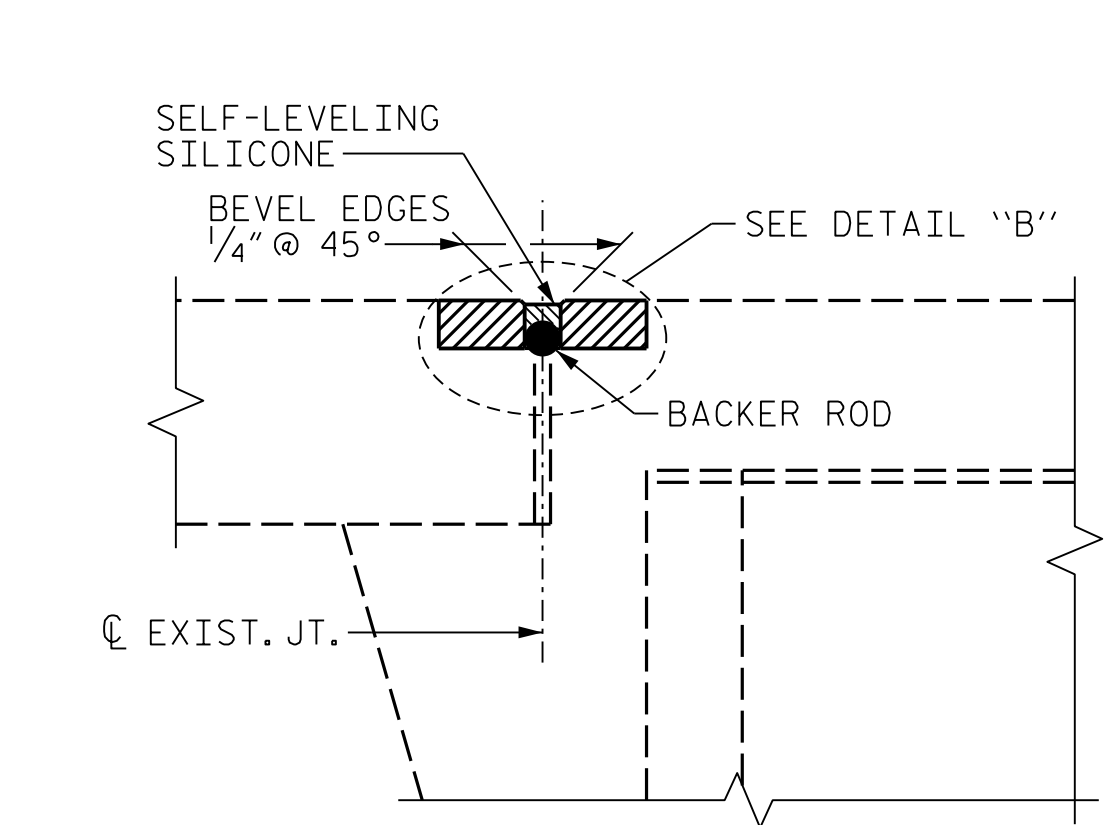

PROPOSED JOINT

NOTES:

REMOVAL OF EXISTING JOINT SHALL RESULT IN THE BOTTOM OF THE BLOCKOUT BEING REASONABLY FLAT AND LEVEL, TO PROVIDE SUFFICIENT SUBSTRATE FOR PLACEMENT AND SUPPORT OF ELASTOMERIC CONCRETE.

RETAIN ALL EXISTING REINFORCING STEEL. CLEAN AND REPAIR AS NEEDED.

THE CONTRACTOR SHALL FIELD VERIFY THE EXISTING JOINT OPENING PRIOR TO ORDERING JOINT SEAL MATERIAL. IF THE ACTUAL JOINT OPENING VARIES FROM THE OPENING INDICATED IN THE DETAILS BY MORE THAN 1/4", NOTIFY THE ENGINEER.

THE MANUFACTURER IS TO PROVIDE THE NOMINAL UNCOMPRESSED SEAL WIDTH OF THE FOAM JOINT SEAL FOR THE SIZE OF THE OPENING ON THE PLANS AND ACCOMMODATE THE MINIMUM EXPANSION SHOWN ON THE PLANS.

FOAM JOINTS SHALL BE INSTALLED AS PER THE MANUFACTURER'S RECOMMENDATIONS.

THE CONTRACTOR SHALL TAKE CARE DURING JOINT REHAB OPERATIONS NOT TO DROP ANY MATERIAL BELOW THE BRIDGE, WITHOUT PROTECTIVE DEVICES BELOW TO CATCH THE MATERIAL. ANY MATERIAL THAT FALLS BELOW THE BRIDGE SHALL BE CONTAINED, REMOVED AND DISPOSED OF BY THE CONTRACTOR AT NO EXTRA COST TO THE DEPARTMENT. IF THE ENGINEER DETERMINES THAT THE PROTECTIVE DEVICES ARE NOT ADEQUATE OR NOT BEING EMPLOYED, THE WORK SHALL BE SUSPENDED UNTIL ADEQUATE PROTECTION IS PROVIDED.

SECTION A-A

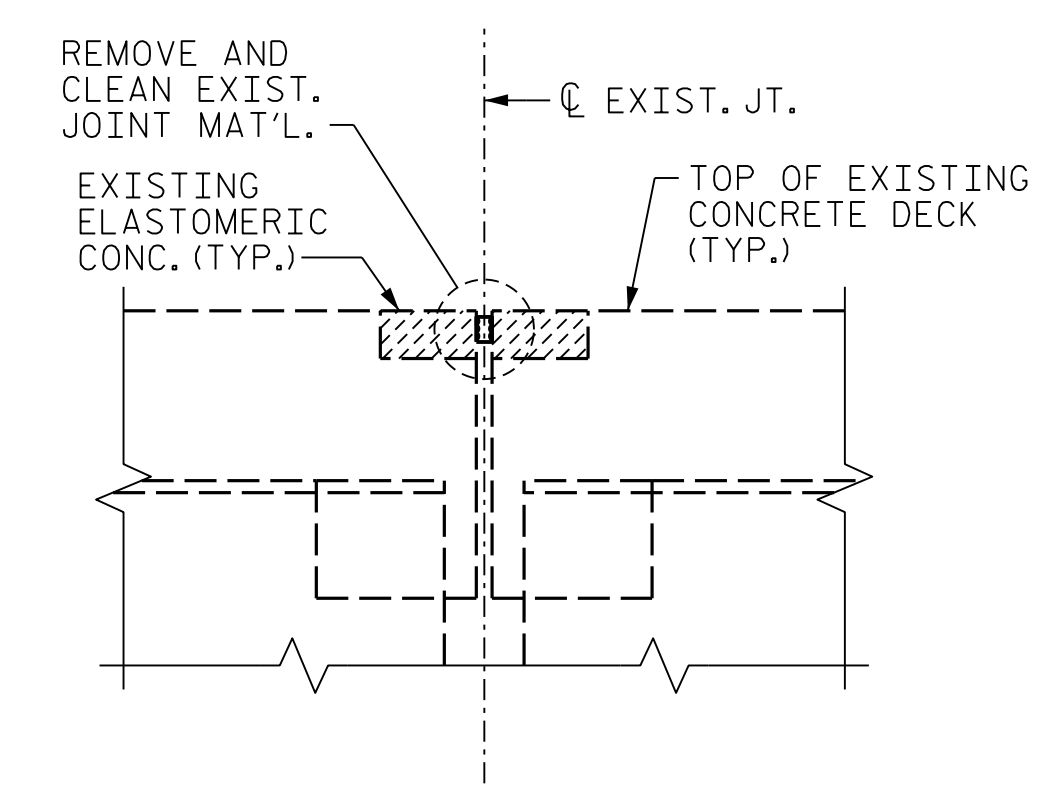

EXISTING JOINT

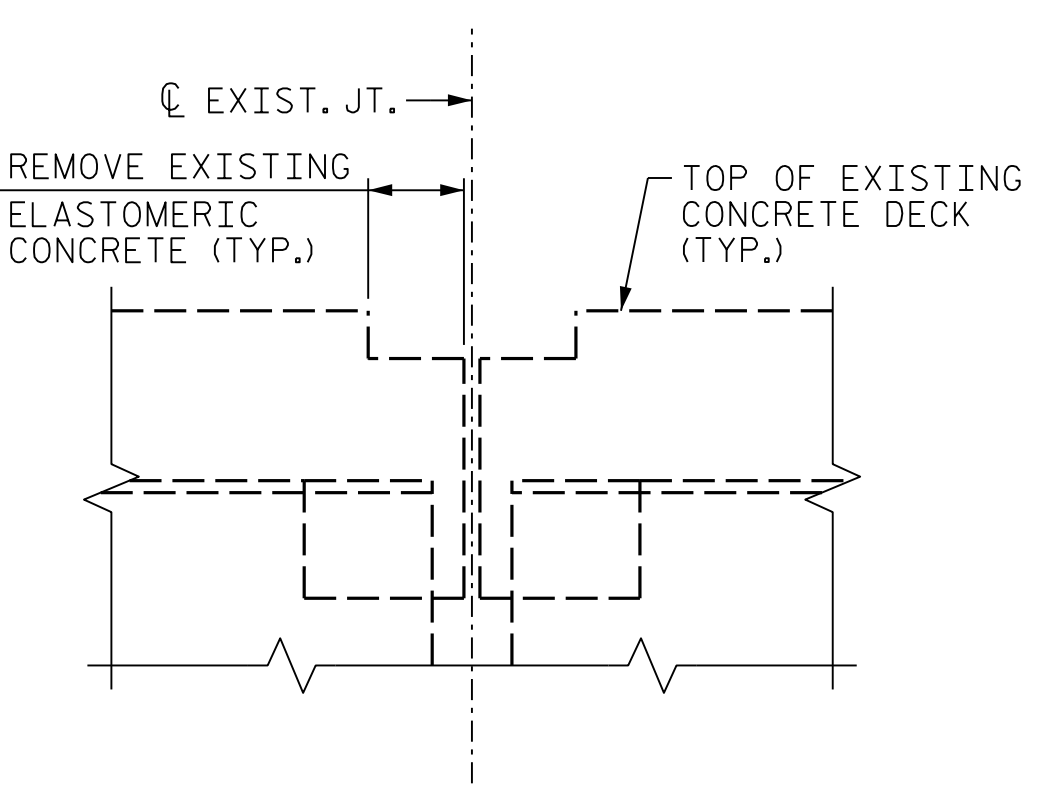

MINIMUM EXISTING JOINT DEMOLITION AT BENT

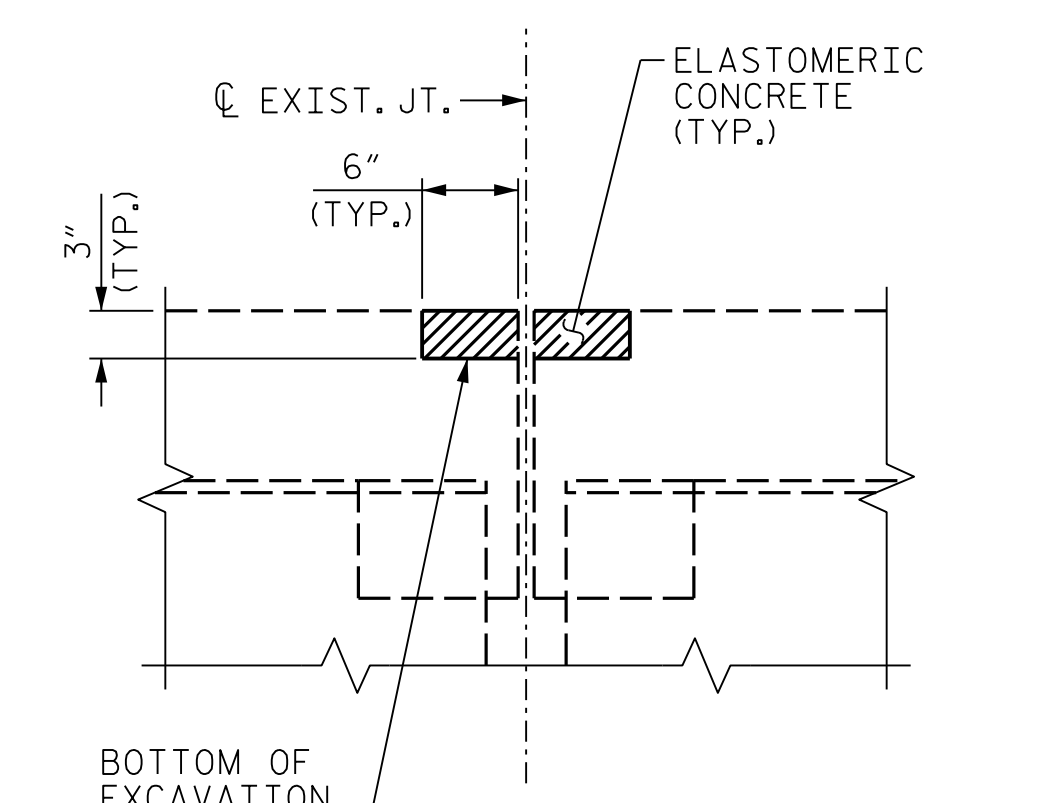

PROPOSED JOINT PRE-SAWED DIMENSIONS

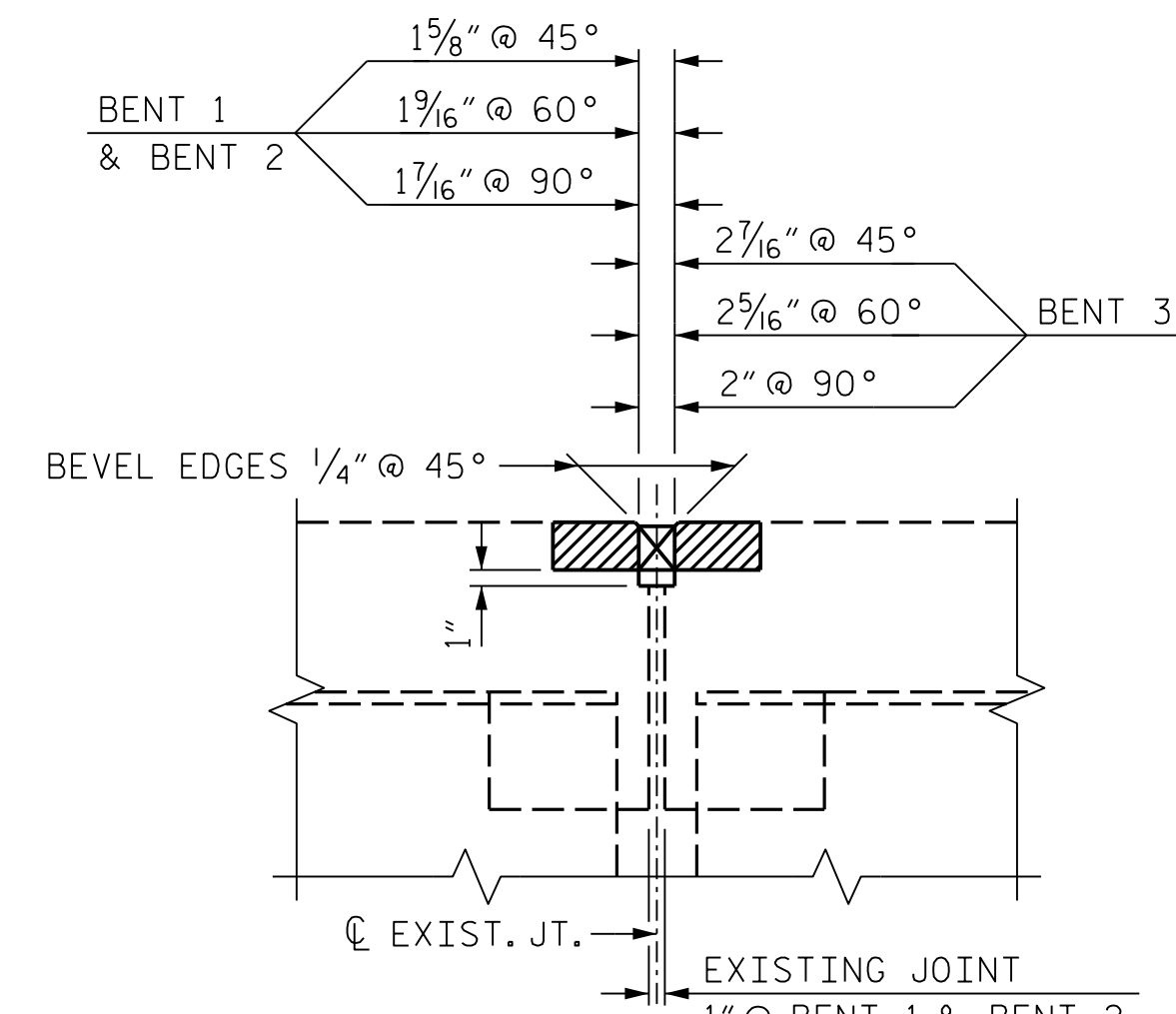

PROPOSED FOAM JOINT SEAL EXPANSION

THE CONTRACTOR WILL NOT BE PERMITTED TO FORM THE JOINTS IN LIEU OF SAWING THE JOINT.

THE INSTALLED FOAM JOINT SEALS SHALL BE WATER TIGHT.

QUANTITIES SHOWN IN THE ELASTOMERIC CONCRETE FOR PRESERVATION TABLE ARE BASED ON THE MINIMUM JOINT DEMOLITION SHOWN.

FINAL SURFACE OF THE JOINT DEMOLITION AREA PRIOR TO PLACEMENT OF CONCRETE REPAIR MATERIAL OR ELASTOMERIC CONCRETE SHOULD BE REASONABLY FLAT AND LEVEL. ENGINEER SHALL DETERMINE THE ACCEPTABILITY OF THE SURFACE PRIOR TO PLACEMENT OF REPAIR CONCRETE OR ELASTOMERIC CONCRETE.

FOR EXCAVATION BELOW THE BOTTOM OF THE PLANNED JOINT DEMOLITION, CONCRETE FOR DECK REPAIR SHALL BE PLACED IN THE EXCAVATED AREA TO THE ELEVATION AT BOTTOM OF THE PROPOSED ELASTOMERIC CONCRETE FOR PRESERVATION HEADERS SHOWN.

FOR BRIDGE JOINT DEMOLITION, SEE SPECIAL PROVISIONS.

FOR FOAM JOINT SEALS FOR PRESERVATION, SEE SPECIAL PROVISIONS.

FOR ELASTOMERIC CONCRETE FOR PRESERVATION, SEE SPECIAL PROVISIONS.

FOR CONCRETE FOR DECK REPAIR, SEE SPECIAL PROVISIONS.

FOR POURABLE SILICONE JOINT SEALANT, SEE SPECIAL PROVISIONS.

SECTION B-B

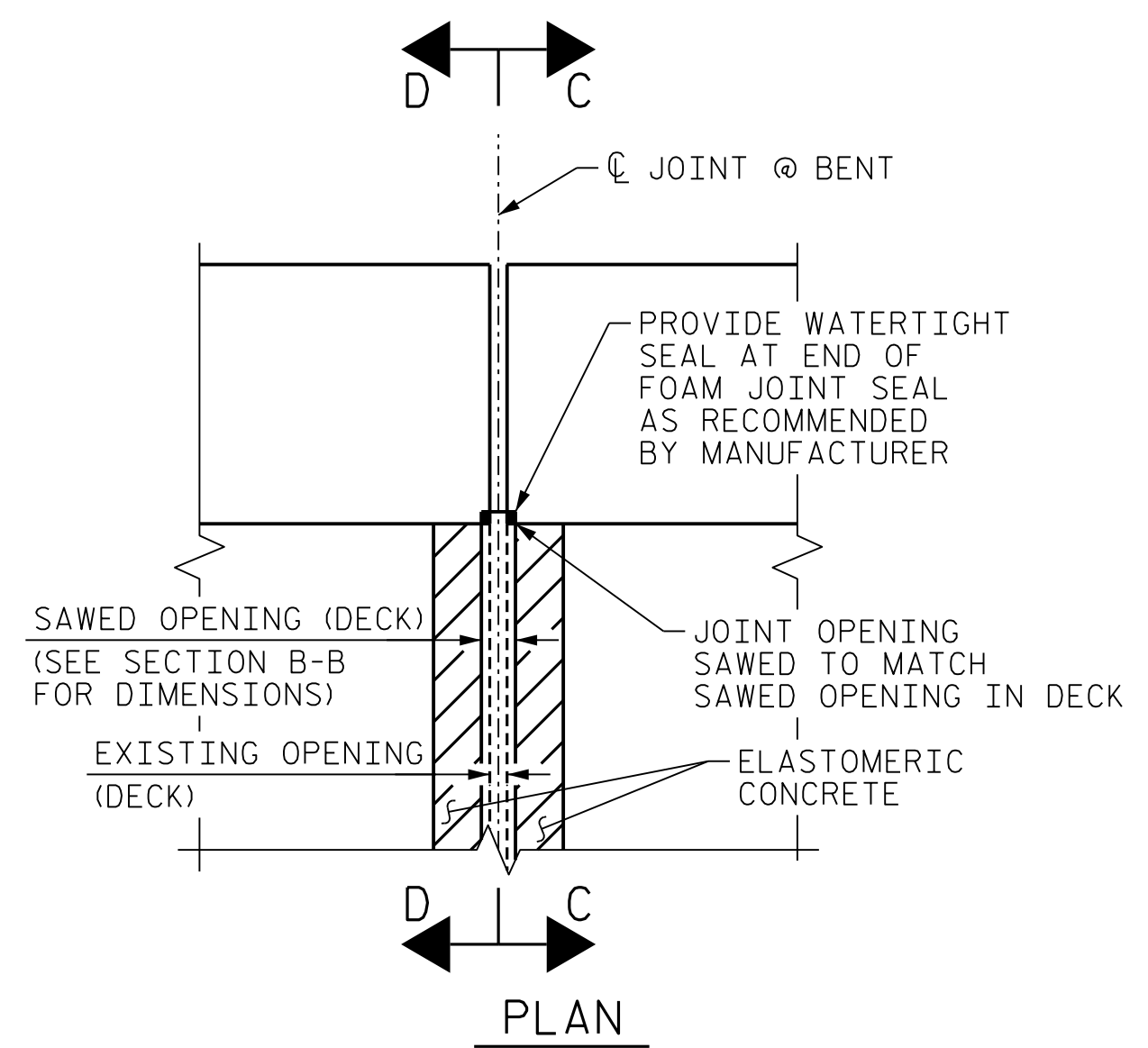

PLAN

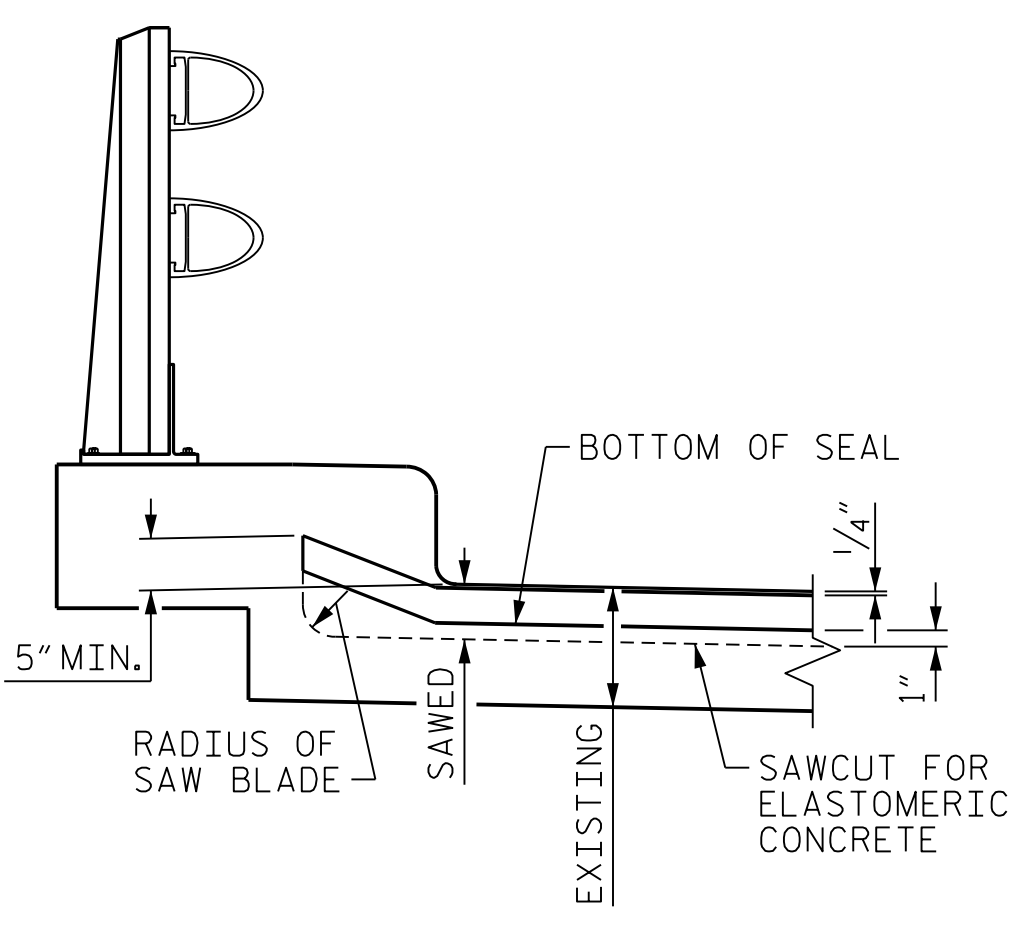

SECTION C-C (LEFT SIDE)

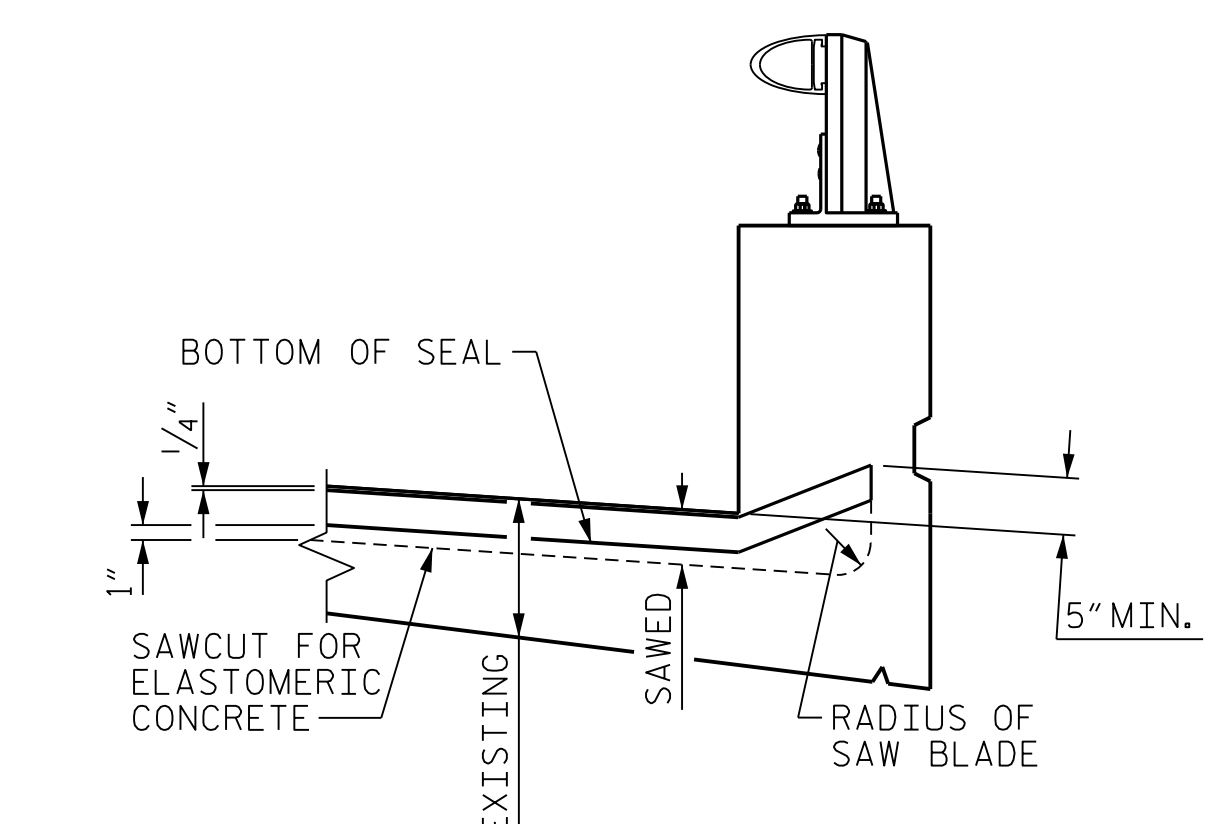

SECTION D-D (RIGHT SIDE)

JOINT DETAILS AT CURB

JOINT REPAIR QUANTITY TABLE

	ESTIMATED	ACTUAL
BRIDGE JOINT DEMOLITION	357.6 SF	
FOAM JOINT SEALS FOR PRESERVATION	219.0 LF	
POURABLE SILICONE JOINT SEALANT	148.6 LF	

ELASTOMERIC CONCRETE FOR PRESERVATION

END BENT 1	18.8	CF
BENT 1	18.4	CF
BENT 2	17.5	CF
BENT 3	17.4	CF
END BENT 2	17.4	CF
* TOTAL	89.5	CF

* BASED ON MINIMUM BLOCKOUT SHOWN.

PROJECT NO. I-6052
 MECKLENBURG COUNTY
 BRIDGE NO. 590339

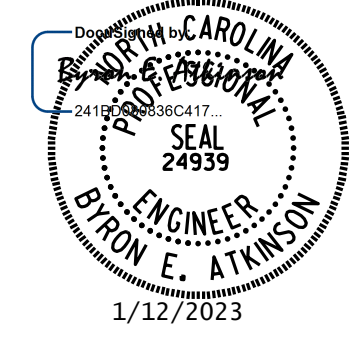

DOCUMENT NOT CONSIDERED FINAL UNLESS ALL SIGNATURES COMPLETED

MI ENGINEERING
 1011 SCHAUB DRIVE, SUITE 100
 RALEIGH, NC 27606
 (919) 851-6606
 FIRM PE NUMBER: P-0671

STATE OF NORTH CAROLINA
 DEPARTMENT OF TRANSPORTATION
 RALEIGH

JOINT DETAILS

REVISIONS						SHEET NO.
NO.	BY:	DATE:	NO.	BY:	DATE:	
1			3			S6-4
2			4			

1/12/2023 9:19:06 AM User: blanning
 File: N:\NC Bridges\W21001.39-I-6052-101 Meck Co.Br. Preservation\Structures\406_007-I-6052-SMU-JT1-590339.dgn

DRAWN BY: B.E. LANNING DATE: 10/2022
 CHECKED BY: B.E. ATKINSON DATE: 10/2022
 DESIGN ENGINEER OF RECORD: B.E. ATKINSON DATE: 10/2022

TOTAL SHEETS 108