

NOTES

ALL PRESTRESSING STRANDS SHALL BE 7-WIRE LOW-RELAXATION GRADE 270 STRANDS AND SHALL CONFORM TO AASHTO M203 EXCEPT FOR SAMPLING REQUIREMENTS WHICH SHALL BE IN ACCORDANCE WITH THE STANDARD SPECIFICATIONS.

ALL REINFORCING STEEL SHALL BE GRADE 60.

EMBEDDED PLATE "B-1" SHALL BE GALVANIZED IN ACCORDANCE WITH THE STANDARD SPECIFICATIONS.

ANCHOR STUDS SHALL CONFORM TO AASHTO M169 GRADES 1010 THROUGH 1020 OR APPROVED EQUAL, AND SHALL MEET THE TYPE "B" REQUIREMENTS OF SUBSECTION 7.3 OF THE ANSI/AASHTO/AWS D1.5 BRIDGE WELDING CODE.

AT ENDS OF GIRDERS TO BE EMBEDDED IN CONCRETE DIAPHRAGMS OR END WALLS, PRESTRESSING STRANDS MAY EXTEND A MAXIMUM OF 2" BEYOND THE GIRDER ENDS. OTHERWISE, PRESTRESSING STRANDS SHALL BE CUT FLUSH WITH THE GIRDER ENDS.

THE TRANSFER OF LOAD FROM THE ANCHORAGES TO THE GIRDER SHALL BE DONE WHEN CONCRETE HAS REACHED A COMPRESSIVE STRENGTH OF NOT LESS THAN 5200 PSI.

DEPENDING ON THE TYPE OF SYSTEM USED TO SUPPORT THE DECK SLAB FORMS, PRESET ANCHORS MAY BE NECESSARY IN THE PRESTRESSED CONCRETE GIRDER.

THE TOP SURFACE OF THE GIRDER, EXCLUDING THE OUTSIDE 4", SHALL BE RAKED TO A DEPTH OF 1/4".

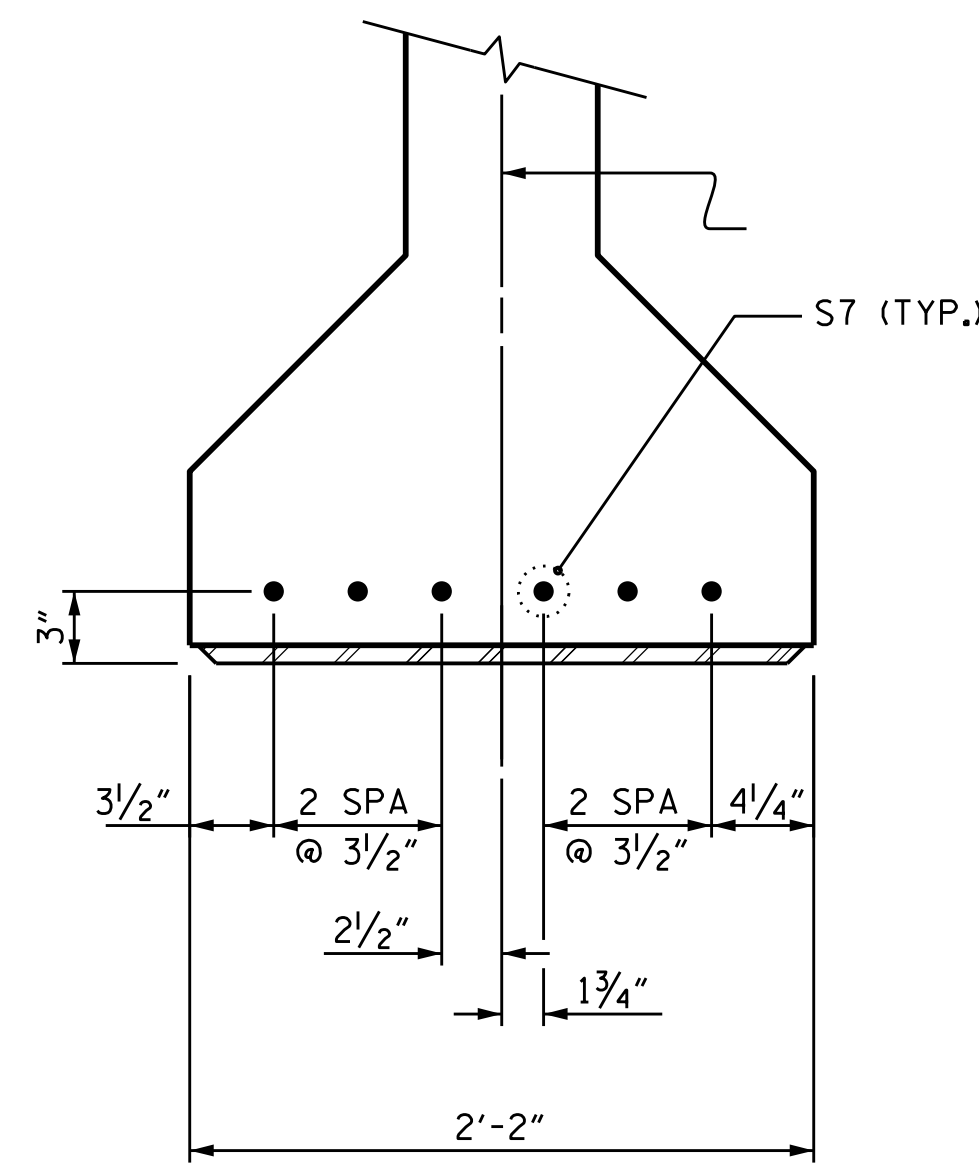

DETAIL "A"

(FOR AASHTO TYPE IV GIRDERS)

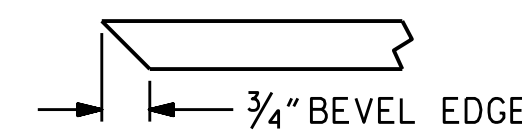

SECTION "F"

(SEE NOTES)

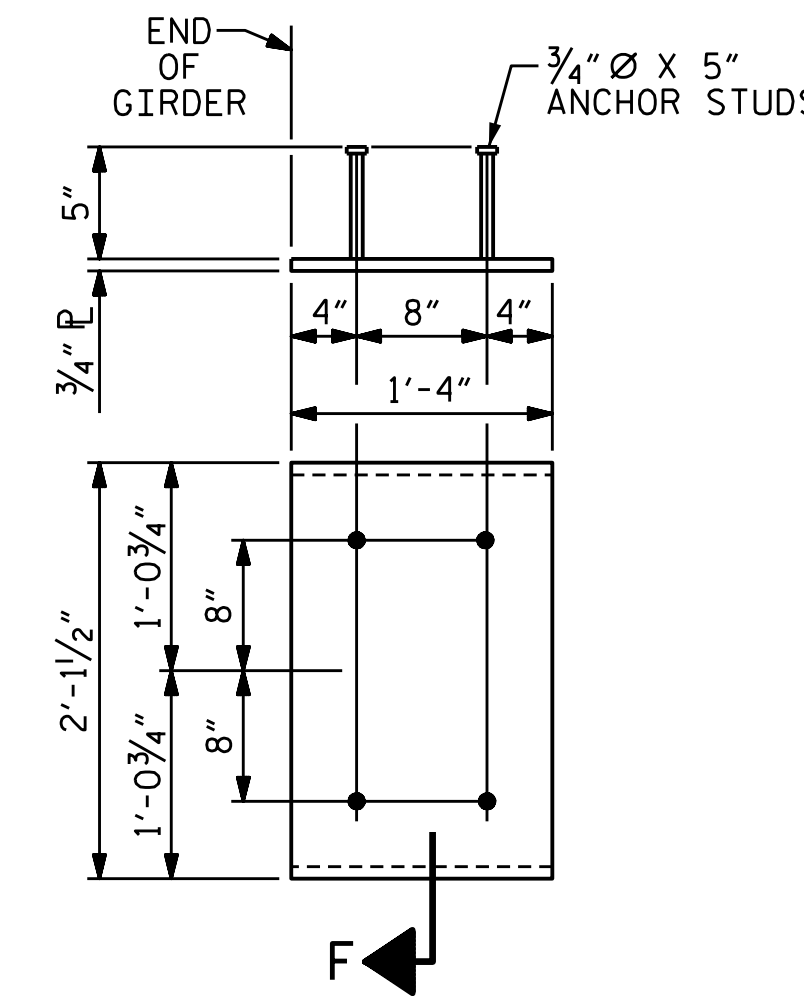

EMBEDDED PLATE "B-1" DETAILS FOR AASHTO TYPE IV GIRDER

(2 REQ'D PER GIRDER)

DEAD LOAD DEFLECTION TABLE FOR GIRDERS																						
0.6" Ø LOW RELAXATION	SPAN A OR B (INTERIOR)																					
TWENTIETH POINTS	0	.05	.10	.15	.20	.25	.30	.35	.40	.45	.50	.55	.60	.65	.70	.75	.80	.85	.90	.95	1.00	
CAMBER ( GIRDER ALONE IN PLACE )	↑	0.000	0.031	0.062	0.091	0.117	0.141	0.160	0.176	0.188	0.195	0.197	0.195	0.188	0.176	0.160	0.141	0.117	0.091	0.062	0.031	0
* DEFLECTION DUE TO SUPERIMPOSED D.L.	↓	0.000	0.022	0.040	0.063	0.079	0.097	0.110	0.122	0.129	0.134	0.136	0.134	0.129	0.122	0.110	0.097	0.079	0.063	0.040	0.022	0
FINAL CAMBER	↑	0	1/8"	1/4"	5/16"	7/16"	1/2"	5/8"	5/8"	11/16"	3/4"	3/4"	3/4"	11/16"	5/8"	5/8"	1/2"	7/16"	5/16"	1/4"	1/8"	0

DEAD LOAD DEFLECTION TABLE FOR GIRDERS																						
0.6" Ø LOW RELAXATION	SPAN A OR B (EXTERIOR)																					
TWENTIETH POINTS	0	.05	.10	.15	.20	.25	.30	.35	.40	.45	.50	.55	.60	.65	.70	.75	.80	.85	.90	.95	1.00	
CAMBER ( GIRDER ALONE IN PLACE )	↑	0.000	0.031	0.062	0.091	0.117	0.141	0.160	0.176	0.188	0.195	0.197	0.195	0.188	0.176	0.160	0.141	0.117	0.091	0.062	0.031	0
* DEFLECTION DUE TO SUPERIMPOSED D.L.	↓	0.000	0.025	0.046	0.072	0.091	0.111	0.126	0.139	0.148	0.154	0.156	0.154	0.148	0.139	0.126	0.111	0.091	0.072	0.046	0.025	0
FINAL CAMBER	↑	0	1/16"	3/16"	1/4"	5/16"	3/8"	7/16"	7/16"	1/2"	1/2"	1/2"	1/2"	1/2"	7/16"	7/16"	3/8"	5/16"	1/4"	3/16"	1/16"	0

\* INCLUDES FUTURE WEARING SURFACE  
ALL VALUES ARE SHOWN IN FEET ( DECIMAL FORM ), EXCEPT " FINAL CAMBER ", WHICH IS GIVEN IN INCHES ( FRACTION FORM ).

PROJECT NO. R-256ICA  
COLUMBUS COUNTY  
STATION: 34+01.72 -Y-

SHEET 2 OF 2

STATE OF NORTH CAROLINA  
DEPARTMENT OF TRANSPORTATION  
RALEIGH  
STANDARD  
PRESTRESSED CONCRETE GIRDER  
CONTINUOUS FOR LIVE LOAD  
DETAILS

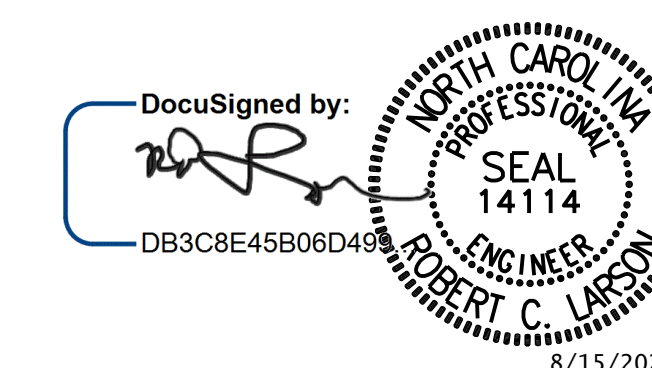

DESIGN ENGINEER OF RECORD	DocuSigned by: [Signature]	DATE: 8/15/2022
ASSEMBLED BY: C. E. LARSON	DATE: 07/31/19	
CHECKED BY: R. C. LARSON	DATE: 07/31/19	
DRAWN BY: ELR 11/91	REV. 1/15	MAA/TMG
CHECKED BY: GRP 11/91	REV. 2/15	MAA/TMG
	REV. 12/17	MAA/THC

DOCUMENT NOT CONSIDERED FINAL  
UNLESS ALL SIGNATURES COMPLETED

ENGINEERS & PLANNERS & SCIENTISTS & CONSTRUCTION MANAGERS	LICENSE NUMBER: C-0784
<b>KCI Associates</b>	
of North Carolina, P.A.	
4205 Folsom Road, Suite 400, Raleigh, NC 27609-6270	Phone: 919-781-9244

REVISIONS						SHEET NO.
NO.	BY:	DATE:	NO.	BY:	DATE:	
1			3			S1-11
2			4			TOTAL SHEETS 28