

8/17/99

# TIERED SKIMMER BASIN DETAIL (EAST)

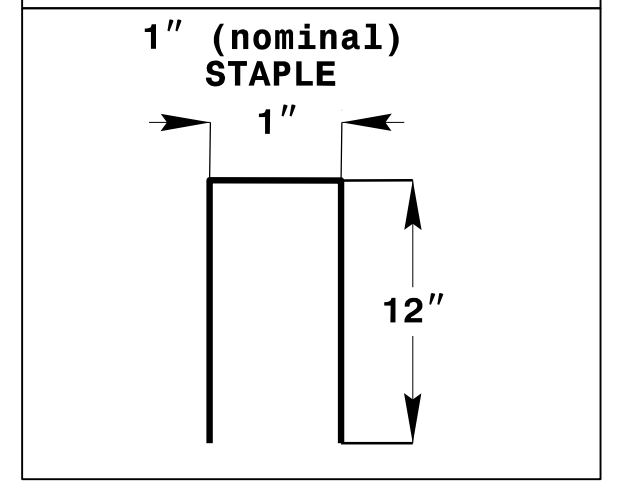
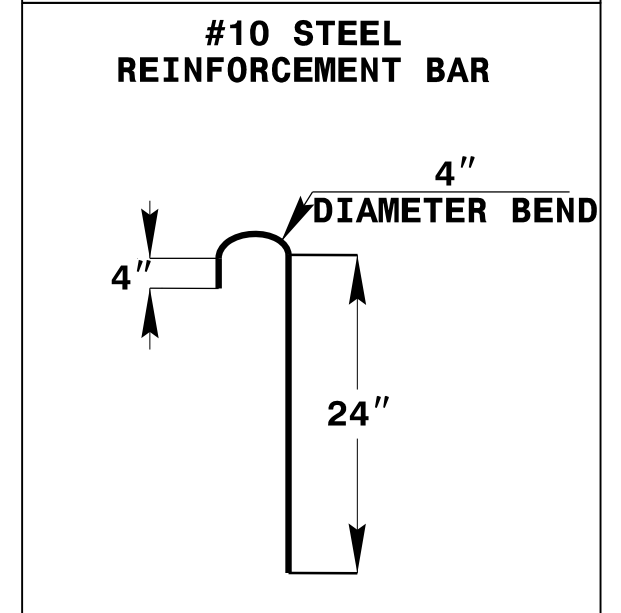
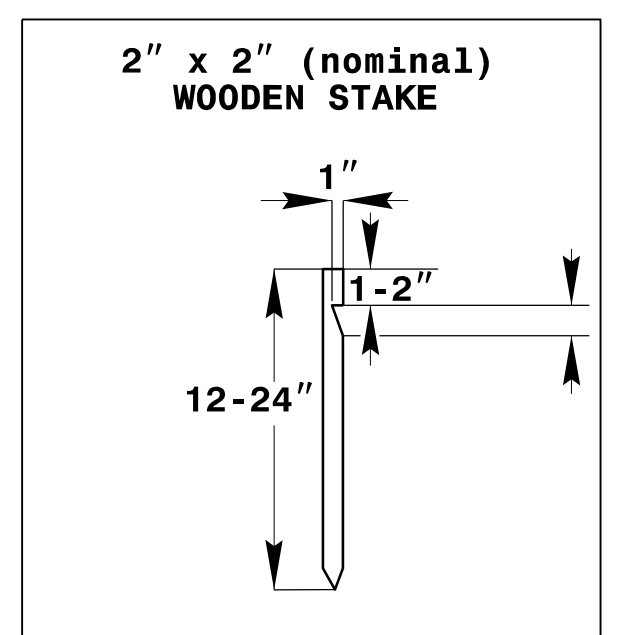
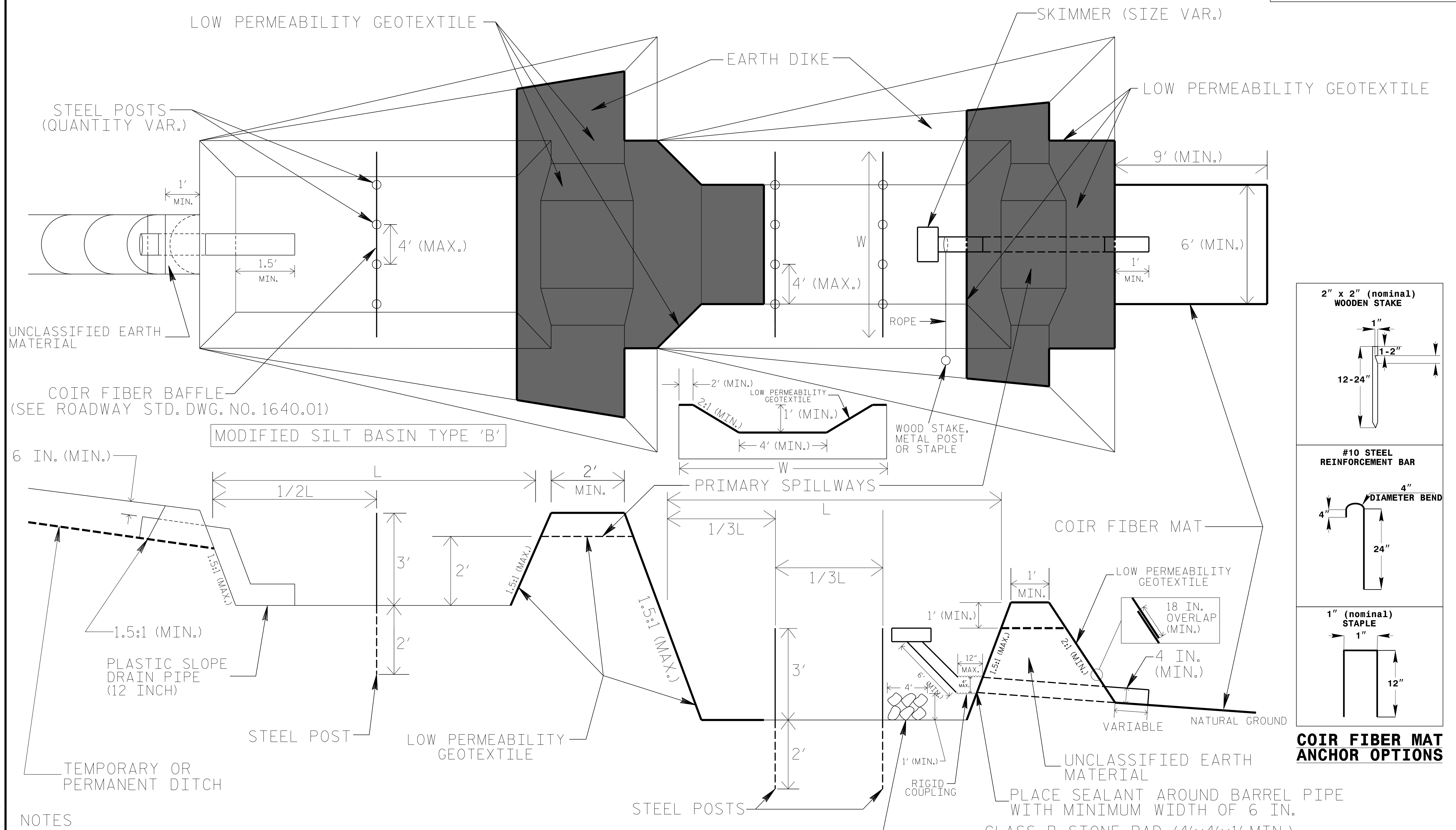

### COIR FIBER MAT ANCHOR OPTIONS

### NOTES

1. SEED AND PLACE MATTING FOR EROSION CONTROL ON INTERIOR AND EXTERIOR SIDESLOPES OF BASINS.
2. LIMIT HEIGHT OF EARTH DIKES TO 5 FT.
3. ADDITIONAL MODIFIED SILT BASINS TYPE 'B' MAY BE NEEDED DEPENDING ON SLOPE.
4. FOR BASIN DEPTHS OF 3FT., THE MINIMUM BASIN WIDTHS SHALL BE 9 FT.
5. DETERMINE PRIMARY SPILLWAY WEIR LENGTHS (FT.) USING  $Q/0.8$ , WHERE Q IS FLOW RATE (CFS) INTO UPPER BASIN.
6. LOW PERMEABILITY GEOTEXTILE FOR PRIMARY SPILLWAYS SHALL BE ONE CONTINUOUS PIECE OF MATERIAL OR OVERLAPPED 18 IN. (MIN.).

NOT TO SCALE

7/9/2020 CA-reu-EC-Details.dgn