

**TYPICAL SECTION**

\* - THE HEIGHT OF THE CURB VARIES WHILE THE TOP OF THE CURB FOLLOWS THE PROFILE OF THE GUTTERLINE. FOR CURB HEIGHT AND CONCRETE WEARING SURFACE THICKNESS, SEE "CONCRETE WEARING SURFACE DETAILS" SHEETS.

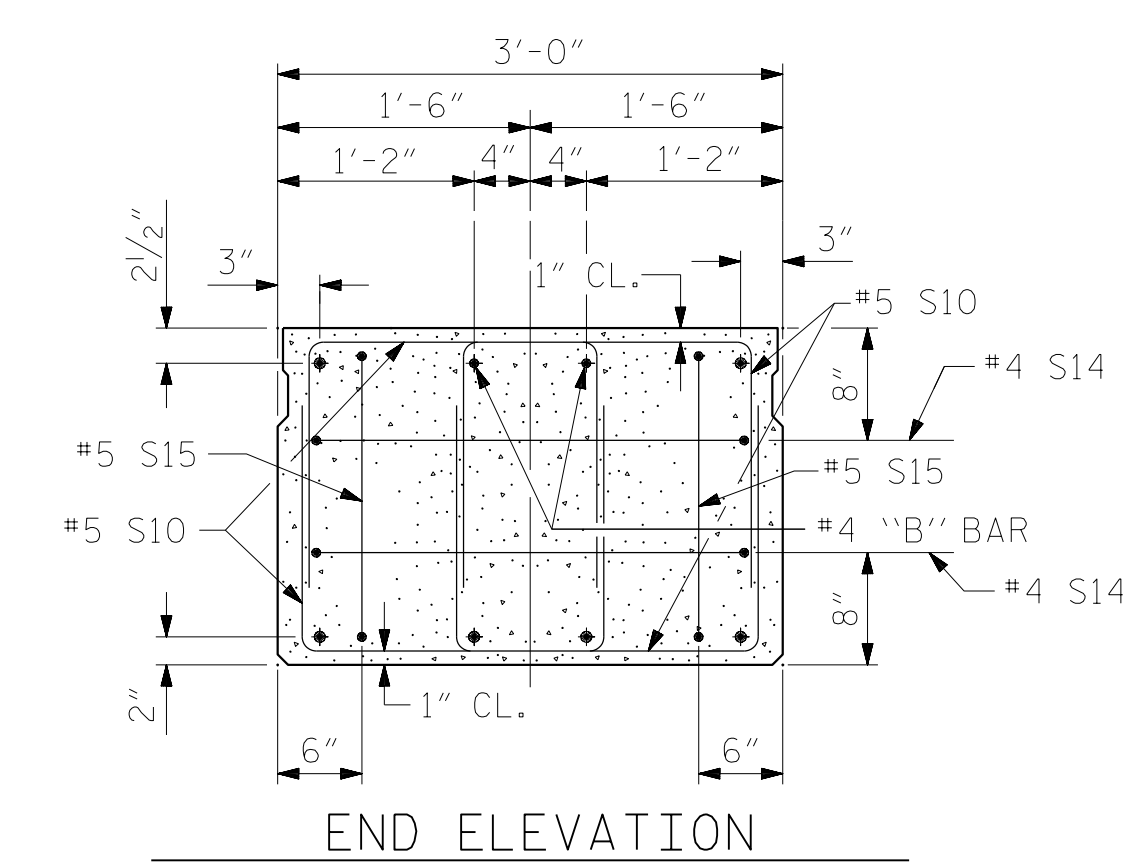

**END ELEVATION**

SHOWING PLACEMENT OF DOUBLE STIRRUPS. FOR LOCATION OF DOWEL HOLES, SEE SHEET 15 OF 16. (STRAND LAYOUT NOT SHOWN.) INTERIOR SLAB SECTION SHOWN-EXTERIOR SLAB SECTION SIMILAR EXCEPT SHEAR KEY LOCATION.

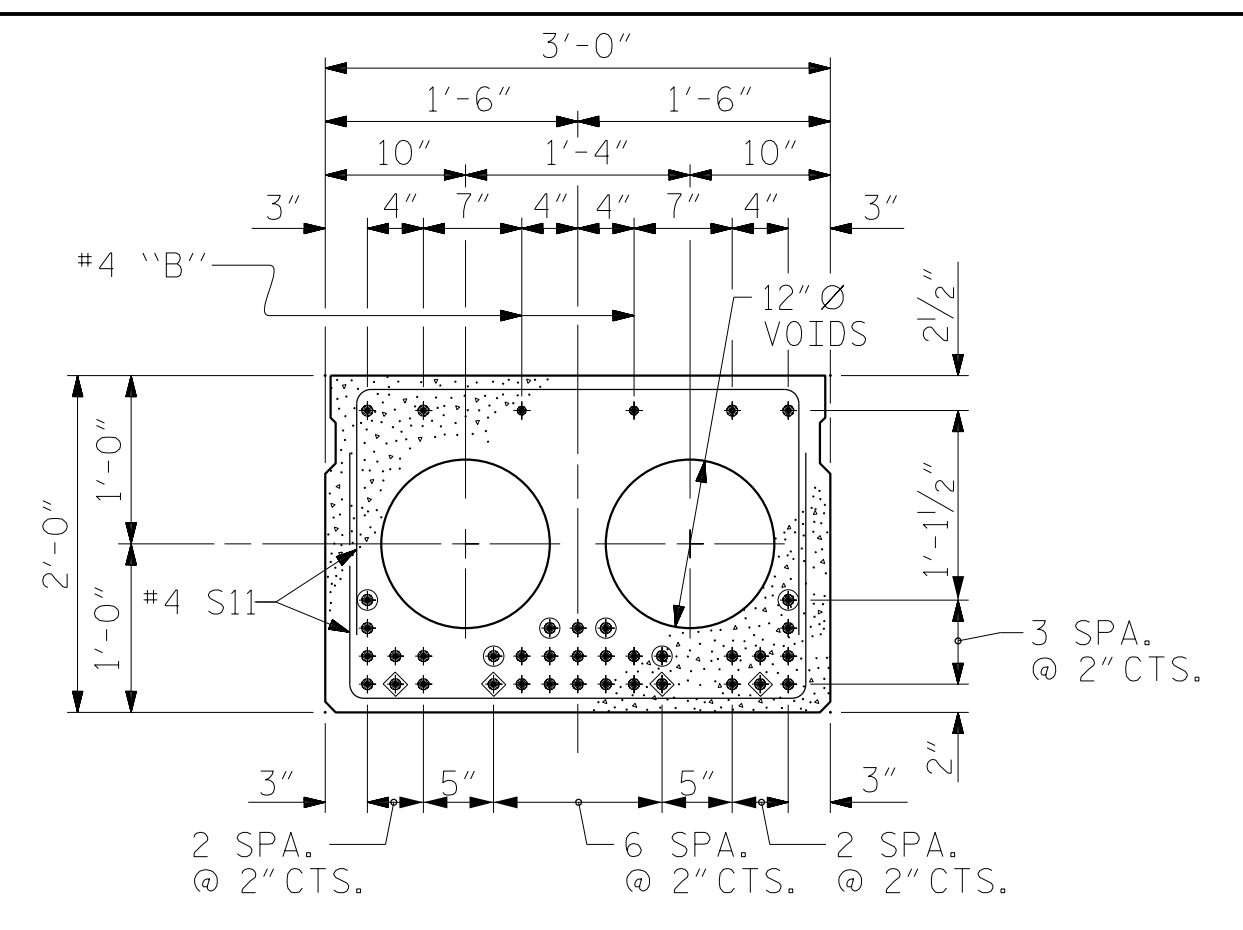

**INTERIOR SLAB SECTION (55' UNIT)**

(31 STRANDS REQUIRED)

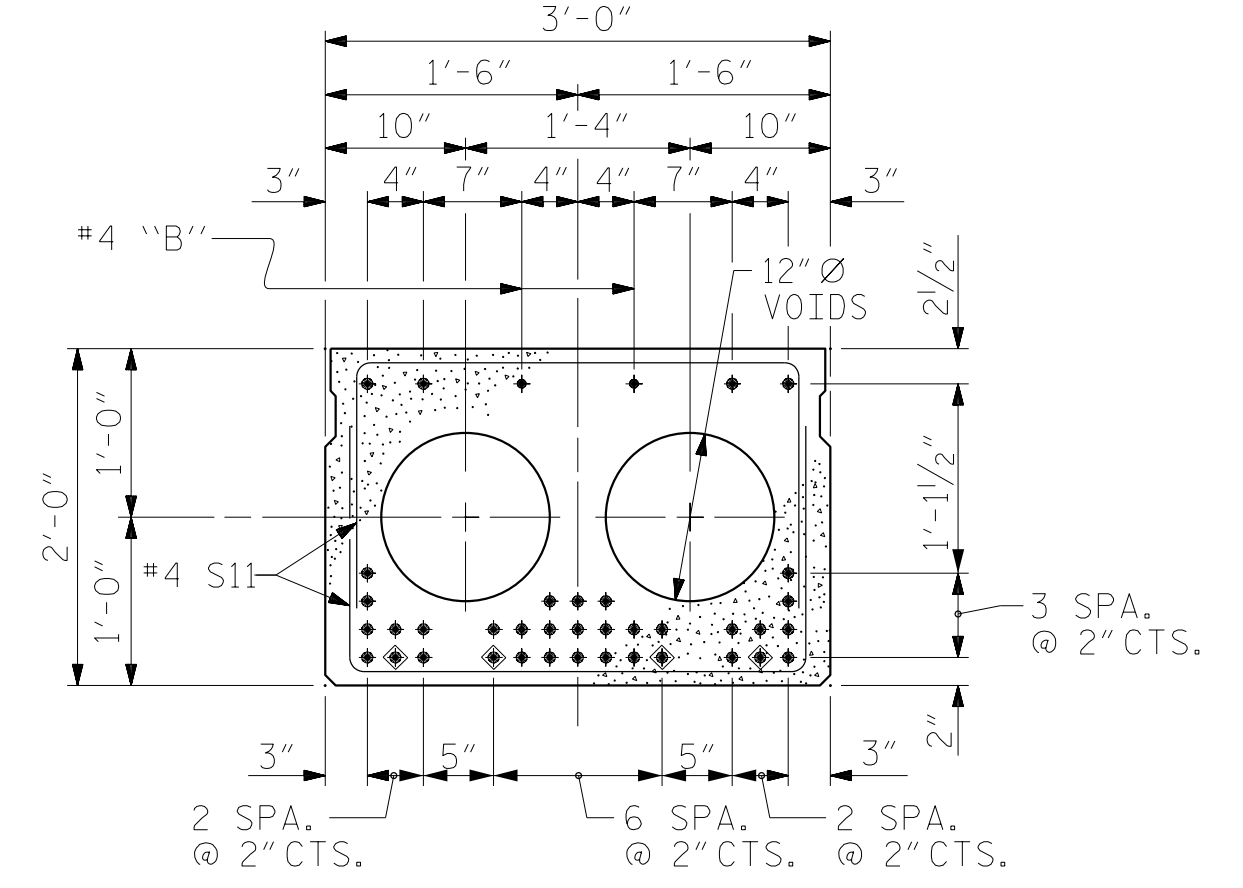

**INTERIOR SLAB SECTION (60' UNIT)**

(37 STRANDS REQUIRED)

**0.6" Ø LOW RELAXATION STRAND LAYOUT**

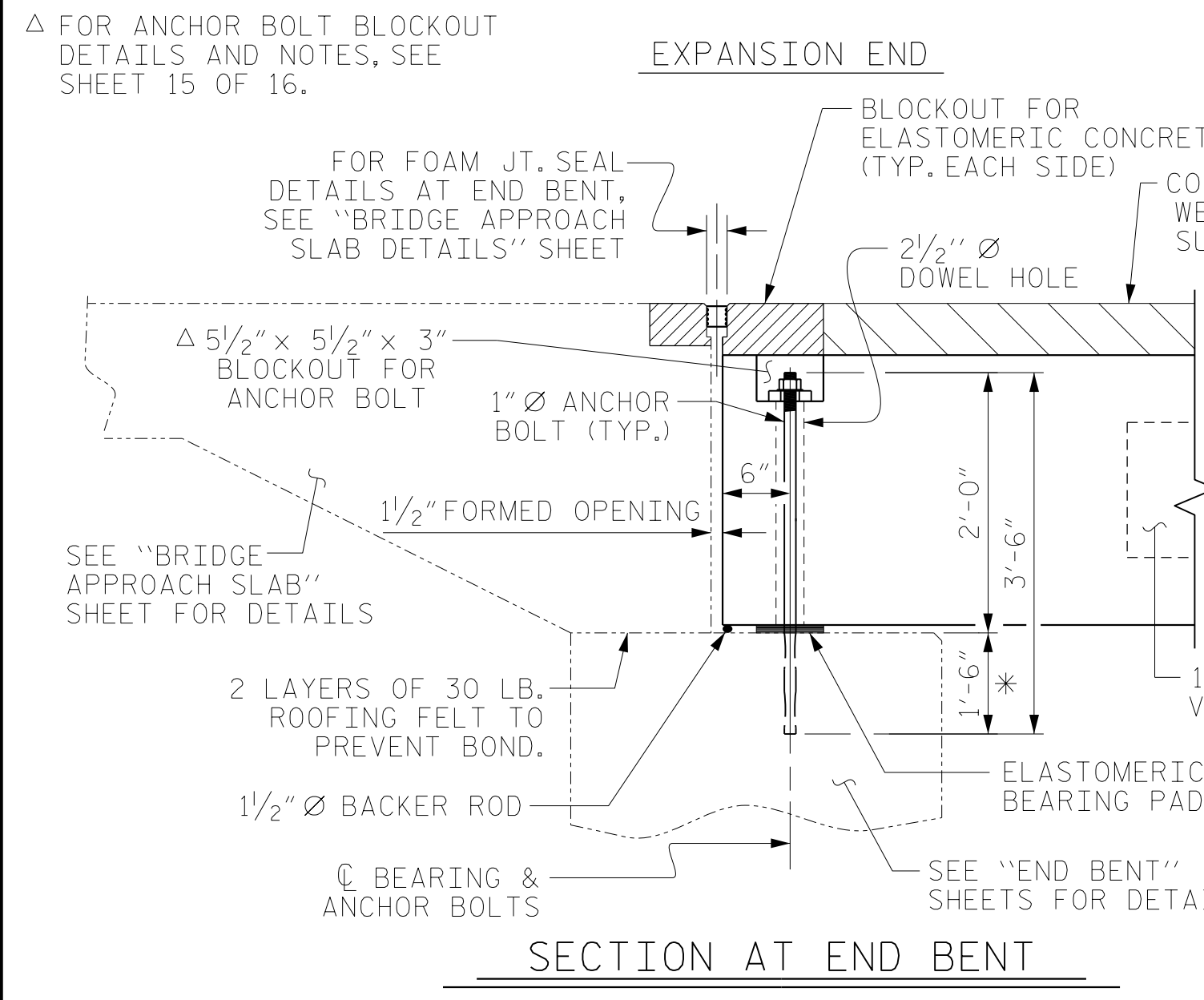

**SECTION AT END BENT**

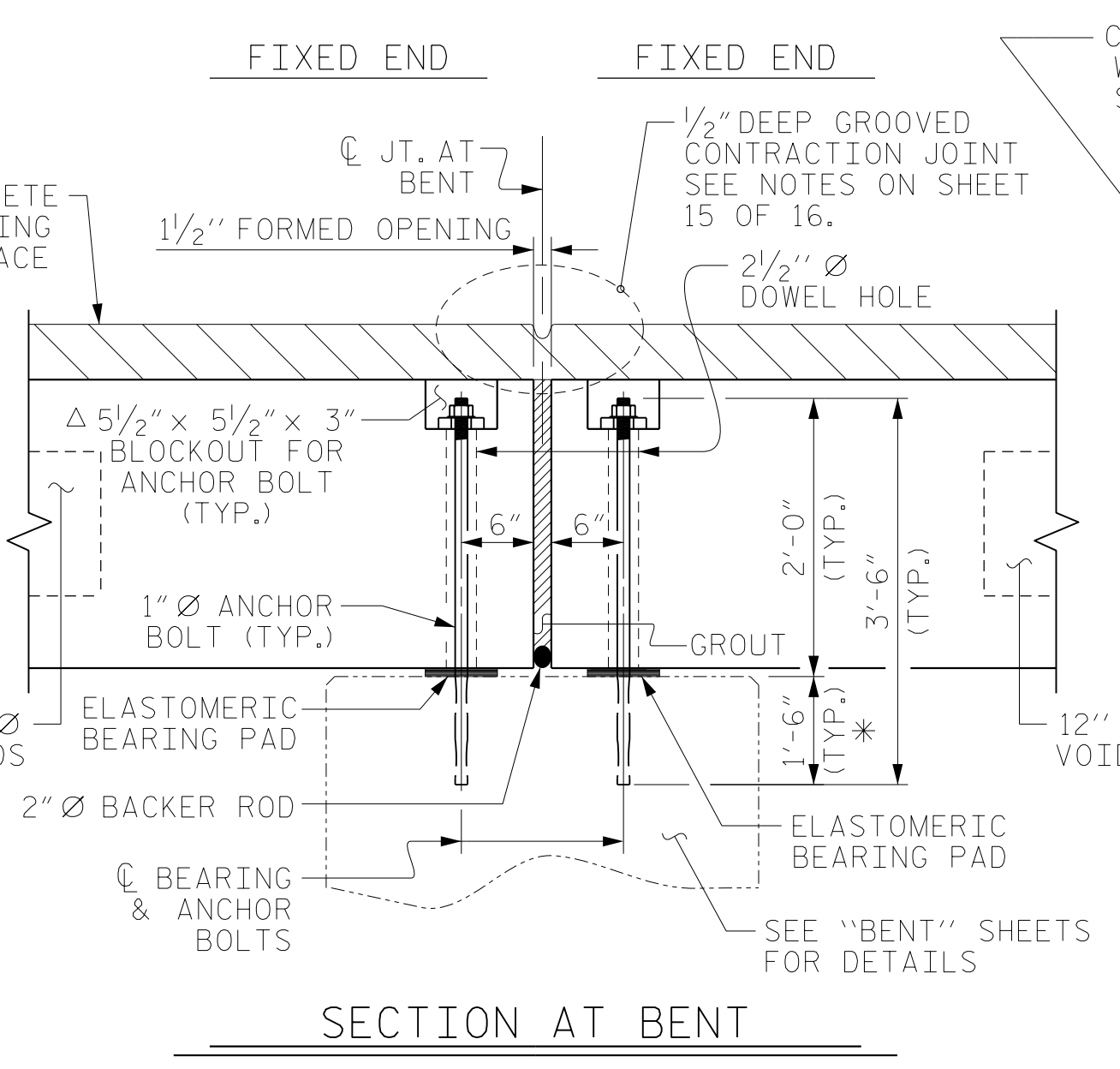

**SECTION AT BENT**

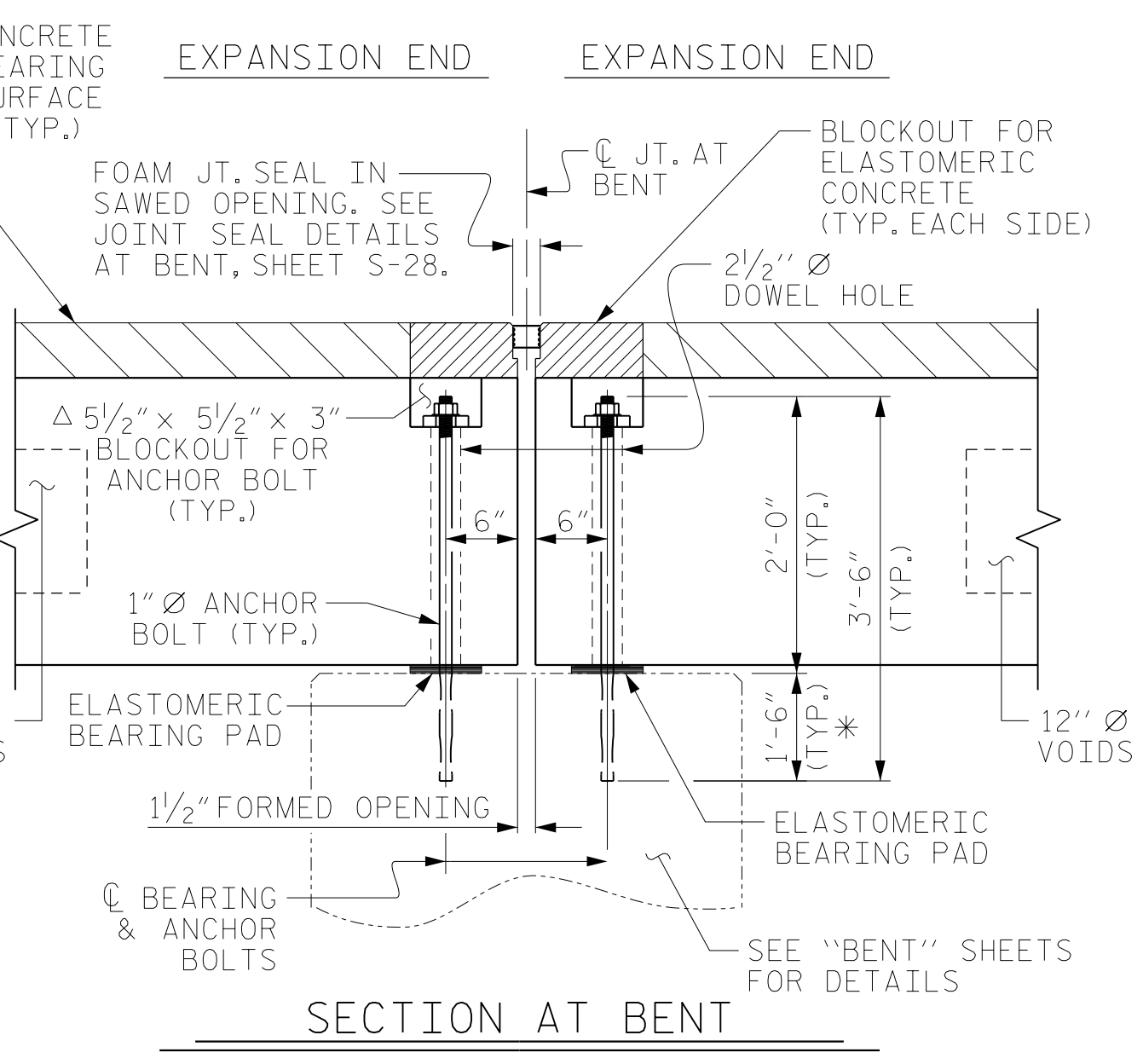

**SECTION AT BENT**

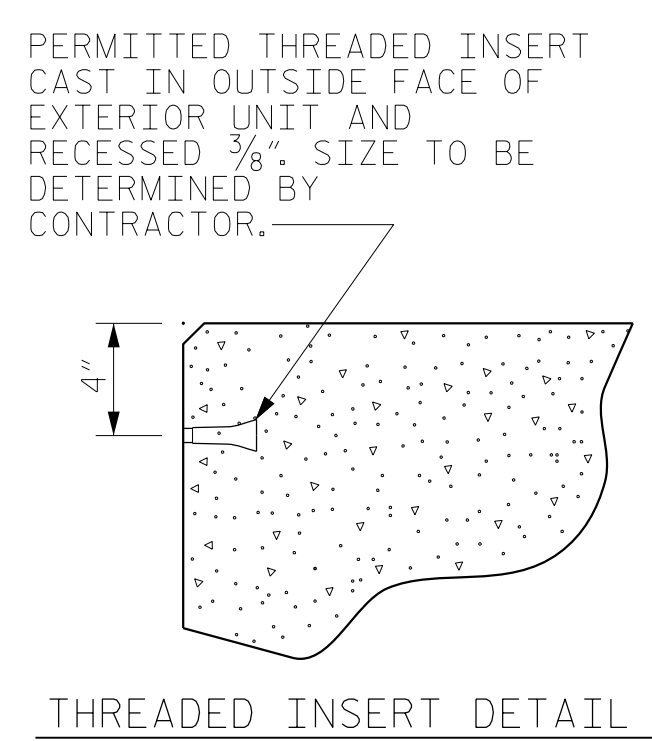

**THREADED INSERT DETAIL**

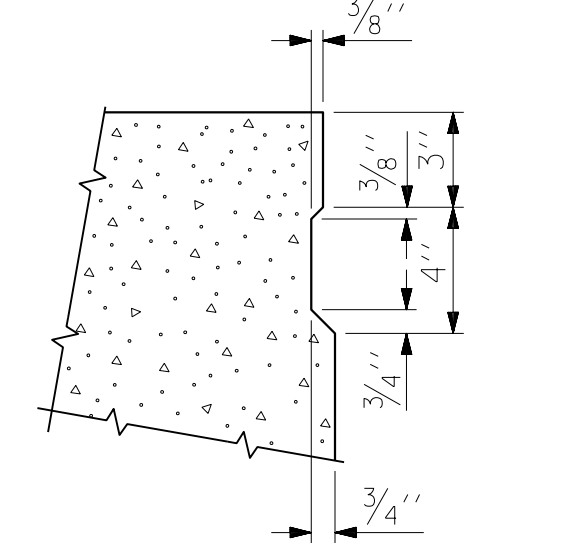

**SHEAR KEY DETAIL**

NOTE: OMIT SHEAR KEY ON OUTSIDE FACE OF EXTERIOR CORED SLABS.

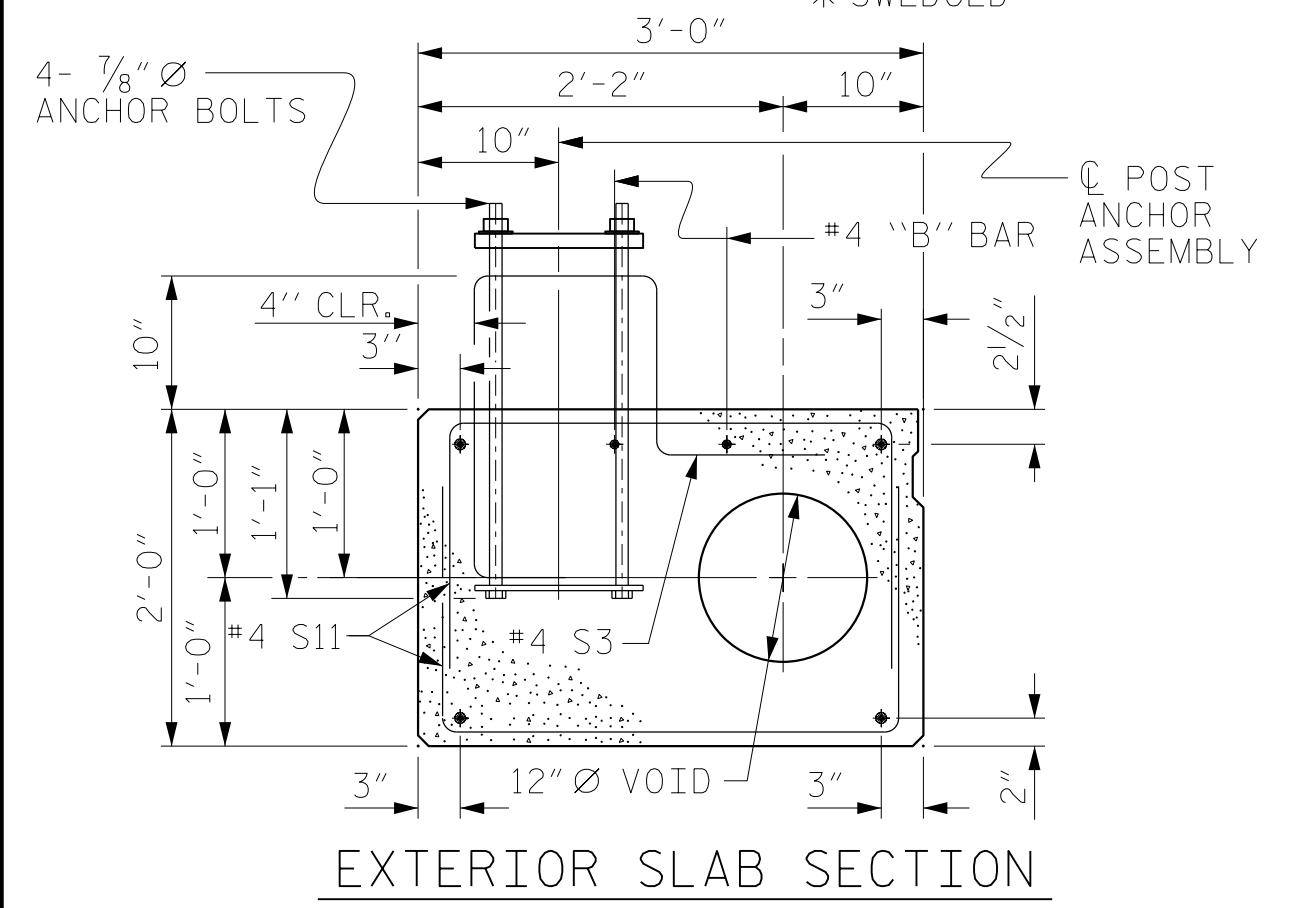

**EXTERIOR SLAB SECTION**

(FOR PRESTRESSED STRAND LAYOUT, SEE INTERIOR SLAB SECTION.)

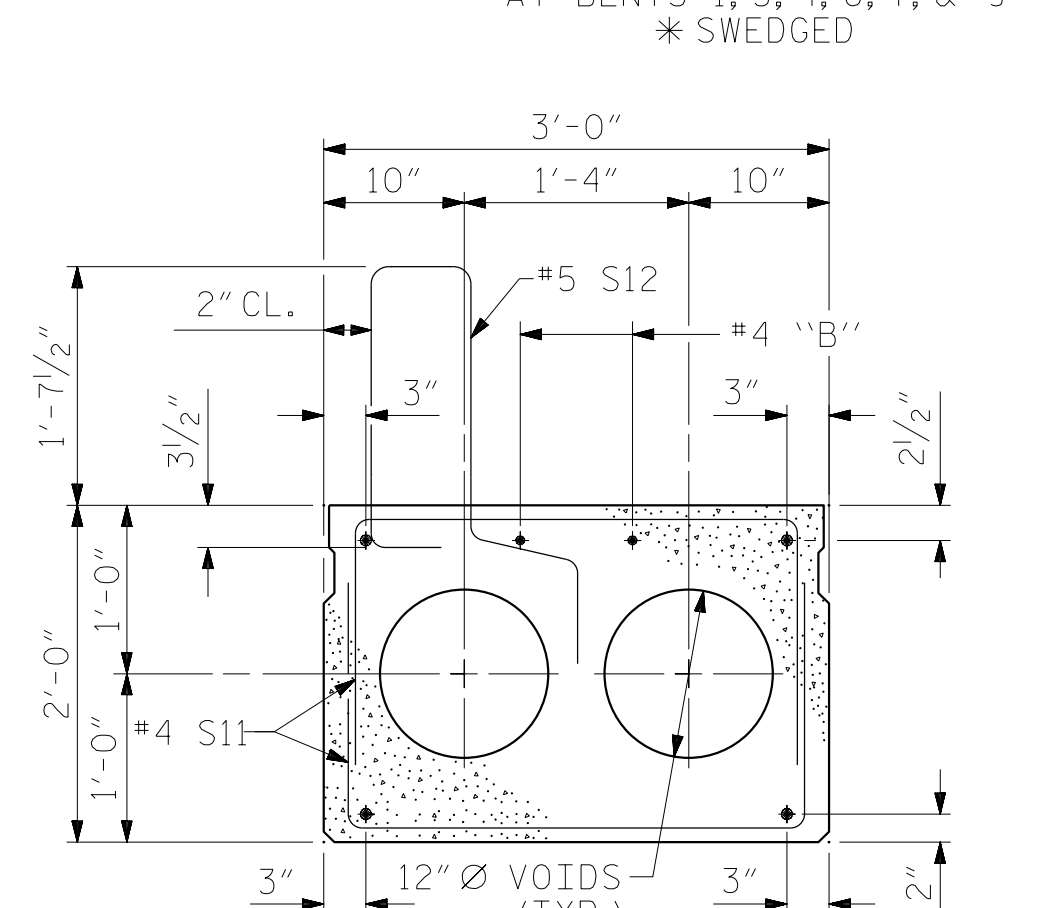

**MODIFIED INTERIOR SLAB SECTION**

(FOR PRESTRESSED STRAND LAYOUT, SEE INTERIOR SLAB SECTION.)

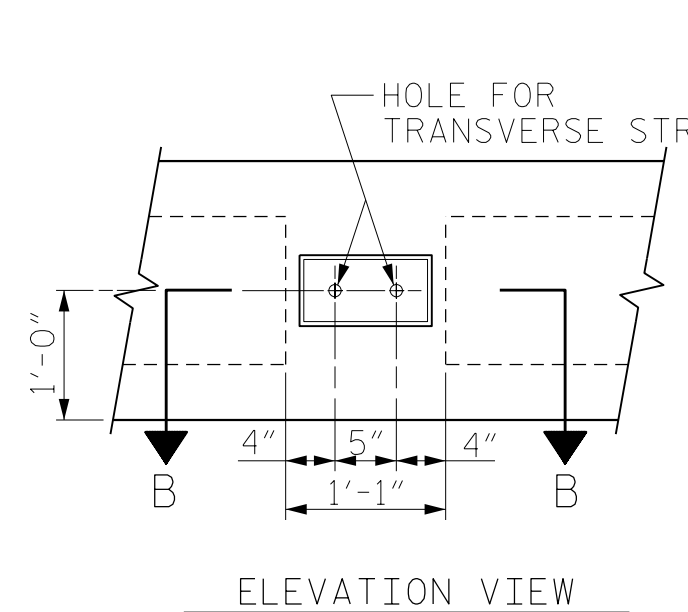

**ELEVATION VIEW**

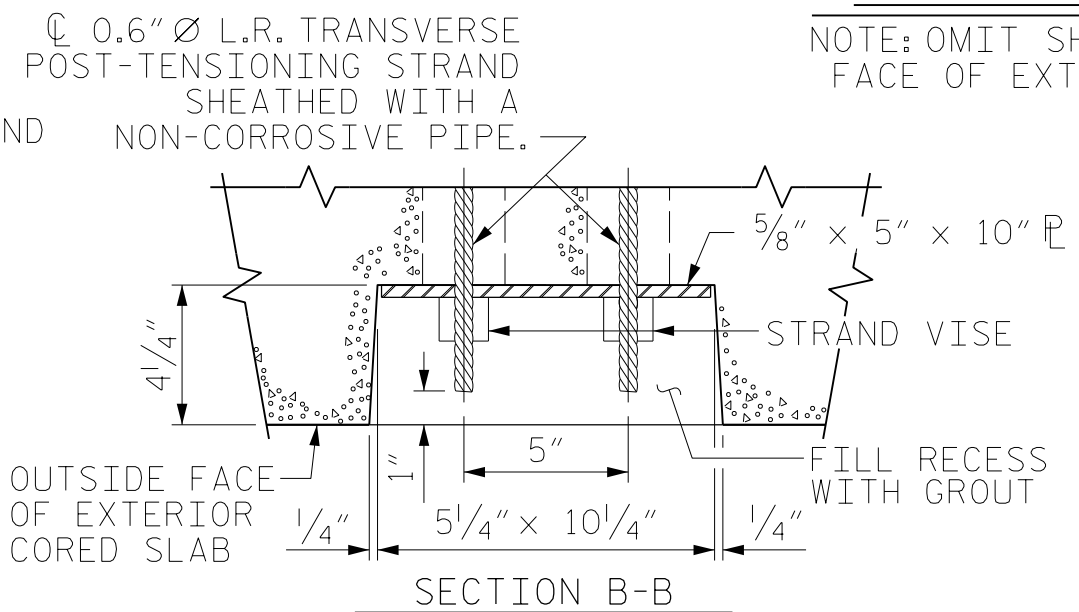

**SECTION B-B**

**GROUTED RECESS AT END OF POST-TENSIONED STRAND-CORED SLABS**

DRAWN BY : MRA DATE : 02/2023  
 CHECKED BY : MKO DATE : 02/2023  
 DESIGN ENGINEER OF RECORD: RLB DATE : 03/2023

DOCUMENT NOT CONSIDERED FINAL UNLESS ALL SIGNATURES COMPLETED

**RS&H**  
 RS&H Architects-Engineers-Planners, Inc.  
 8521 Six Forks Road, Suite 400  
 Raleigh, NC 27615  
 919-926-4100 FAX 919-846-9080  
 www.rsandh.com  
 North Carolina License No. 50737-5403-C&E

PROJECT NO. BR-0160  
BRUNSWICK COUNTY  
 STATION: 21+77.50 -L-

SHEET 1 OF 16

STATE OF NORTH CAROLINA DEPARTMENT OF TRANSPORTATION RALEIGH					
3'-0" X 2'-0" PRESTRESSED CONCRETE CORED SLAB UNIT					
REVISIONS					
NO.	BY:	DATE:	NO.	BY:	DATE:
1			3		
2			4		

SHEET NO.				
S-9				
TOTAL SHEETS				
42				