

COIR FIBER WATTLE BARRIER DETAIL

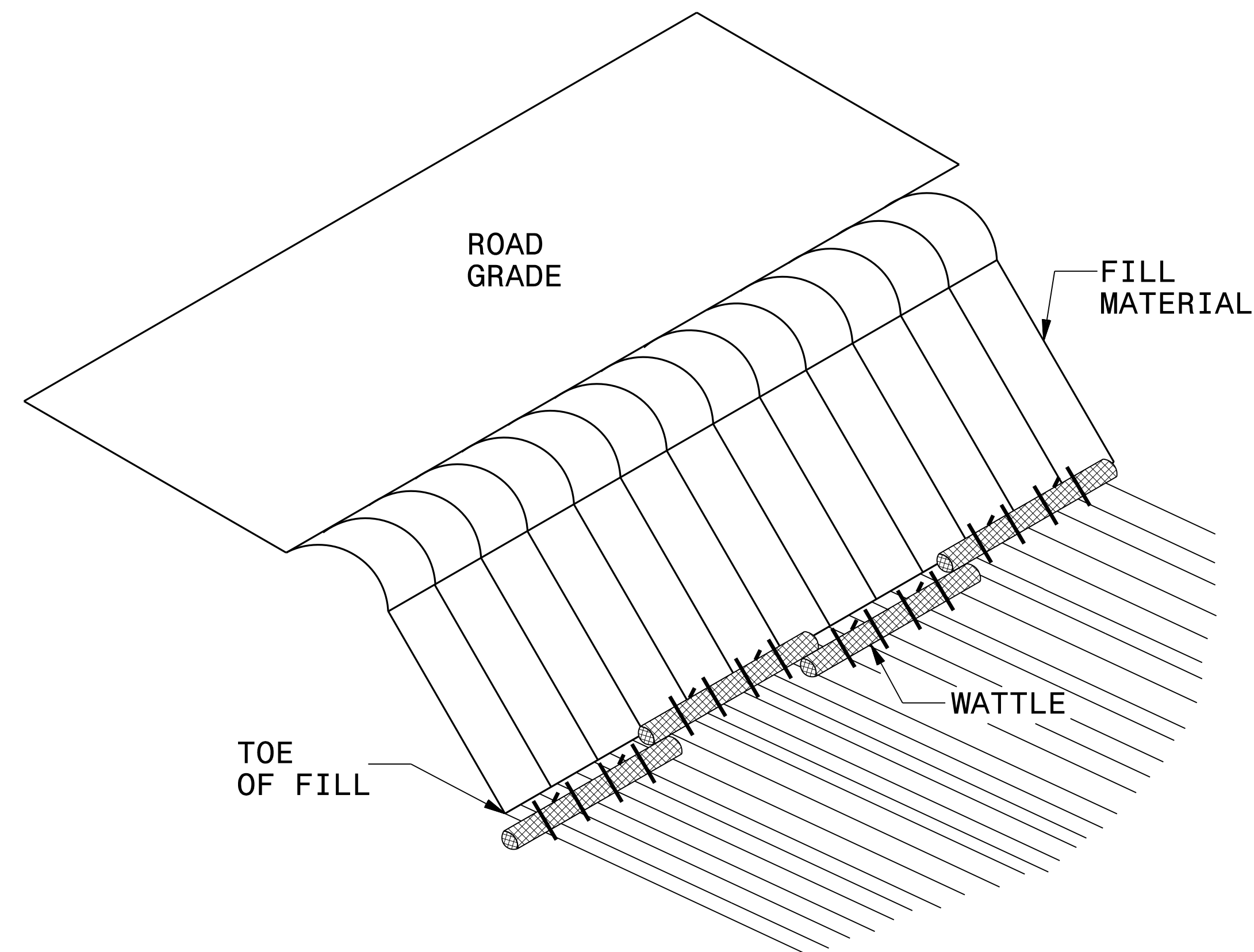

ISOMETRIC VIEW

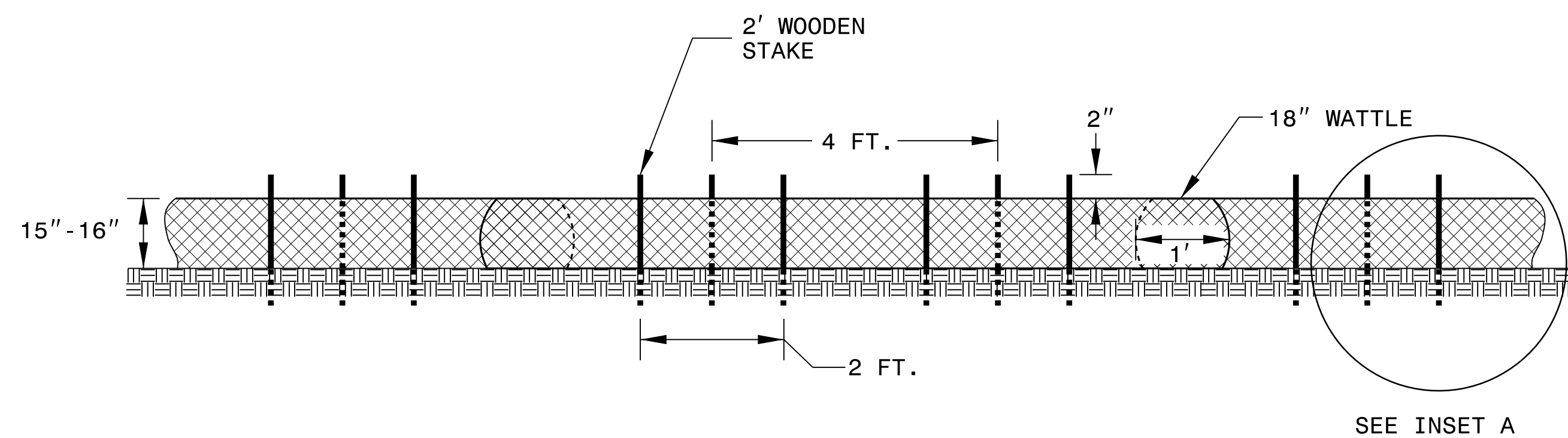

FRONT VIEW

NOTES:

- USE MINIMUM 18 IN. NOMINAL DIAMETER COIR FIBER (COCONUT) WATTLE AND LENGTH OF 10 FT.
- EXCAVATE A 2 TO 3 INCH TRENCH FOR WATTLE TO BE PLACED.
- DO NOT PLACE WATTLES ON TOE OF SLOPE.
- USE 2 FT. WOODEN STAKES WITH A 2 IN. BY 2 IN. NOMINAL CROSS SECTION.
- INSTALL A MINIMUM OF 2 UPSLOPE STAKES AND 4 DOWNSLOPE STAKES AT AN ANGLE TO WEDGE WATTLE TO GROUND.
- PROVIDE STAPLES MADE OF 0.125 IN. DIAMETER STEEL WIRE FORMED INTO A U SHAPE NOT LESS THAN 12" IN LENGTH.
- INSTALL STAPLES APPROXIMATELY EVERY 1 LINEAR FOOT ON BOTH SIDES OF WATTLE AND AT EACH END TO SECURE IT TO THE SOIL.
- FOR BREAKS ALONG LARGE SLOPES, USE MAXIMUM SPACING OF 25 FT.

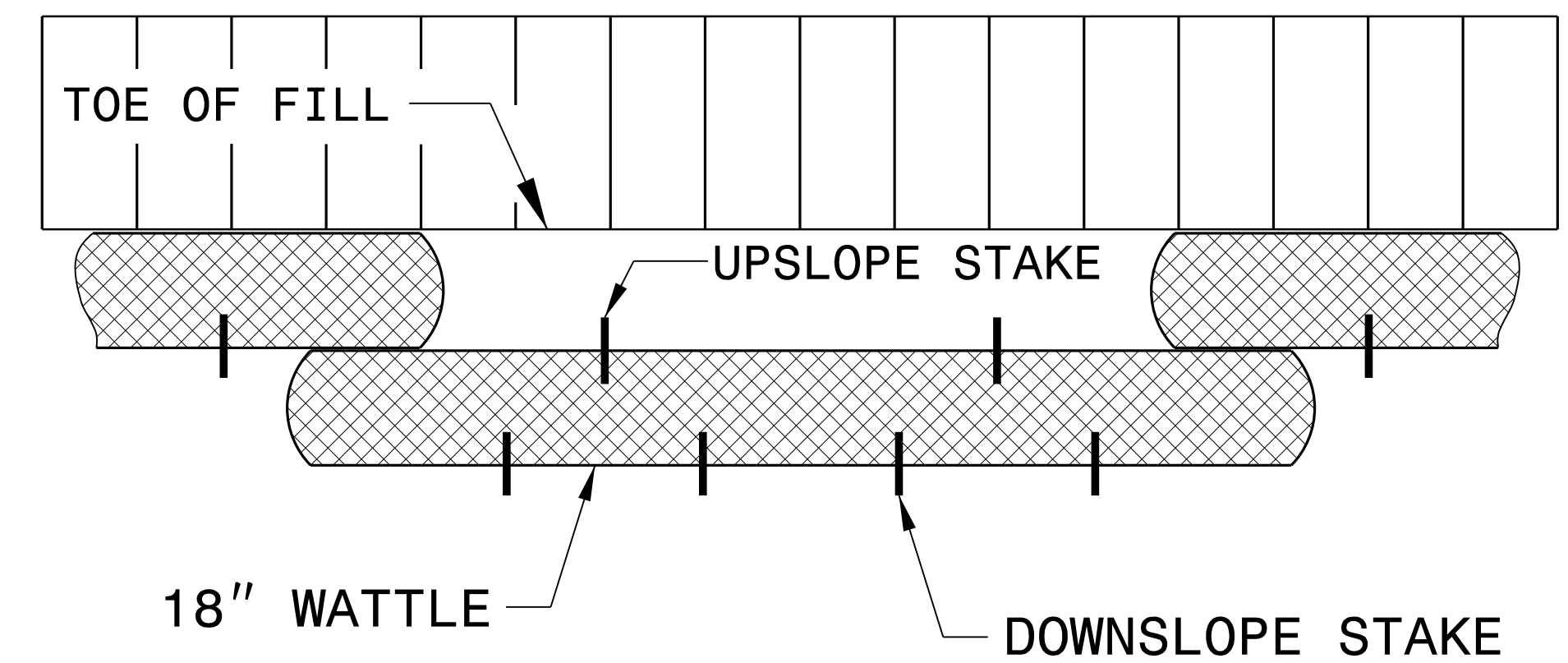
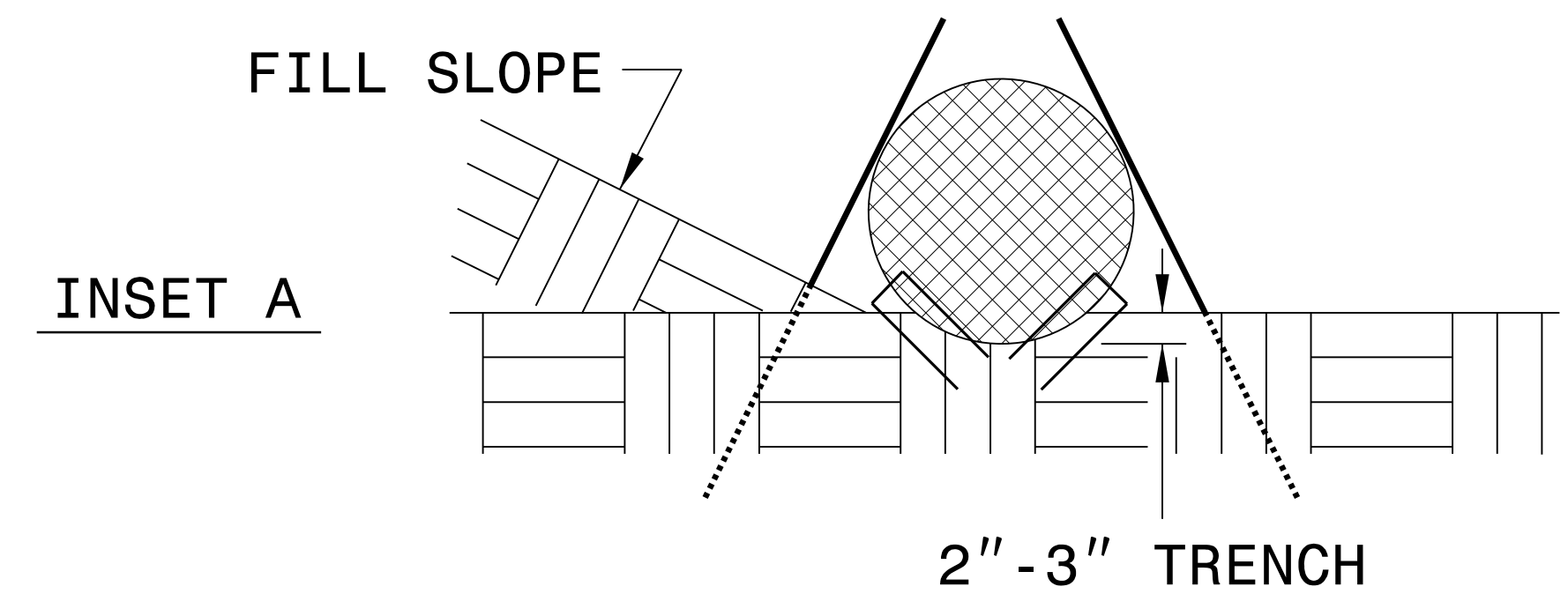

TOP VIEW