

DEFAULT PHASING DIAGRAM

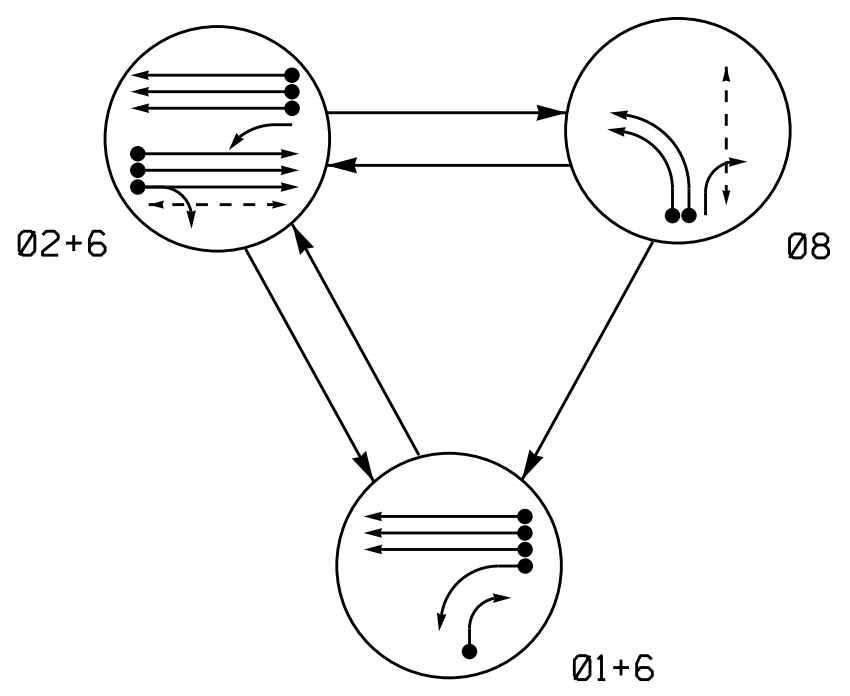

ALTERNATE PHASING DIAGRAM

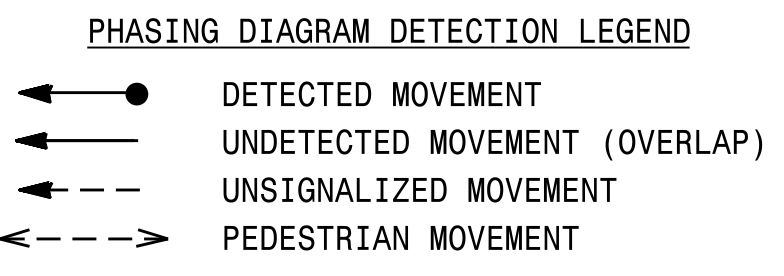
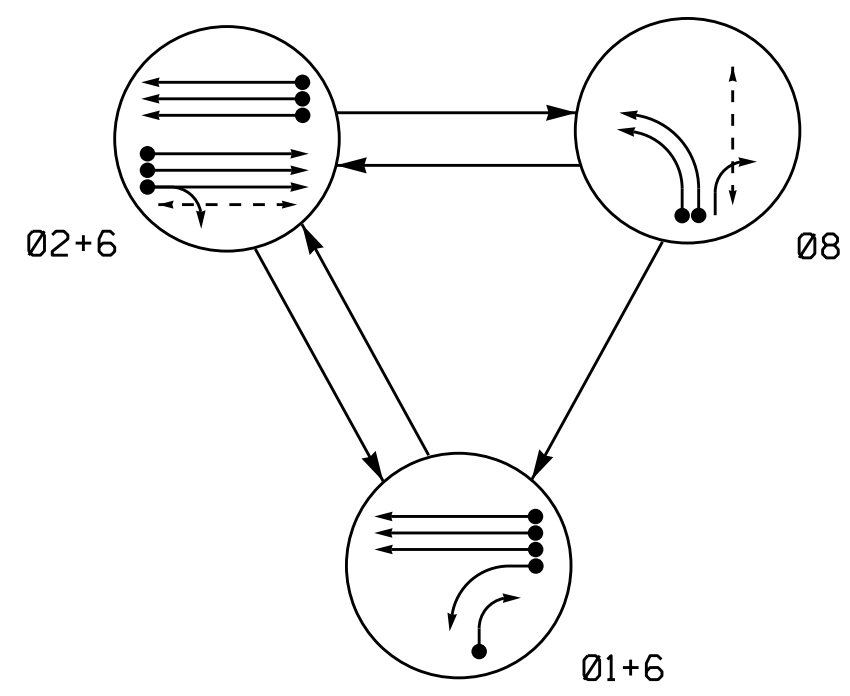

DEFAULT PHASING TABLE OF OPERATION

SIGNAL FACE	PHASE			FL TOP
	01+6	02+6	08	
11	←	←	←	←
21, 22, 23	R	G	R	Y
61, 62, 63	G	G	R	Y
81, 82	←	←	←	←
83	→	←	←	←
P21, P22	DW	W	DW	DRK
P81, P82	DW	DW	W	DRK

ALTERNATE PHASING TABLE OF OPERATION

SIGNAL FACE	PHASE			FL TOP
	01+6	02+6	08	
11	←	←	←	←
21, 22, 23	R	G	R	Y
61, 62, 63	G	G	R	Y
81, 82	←	←	←	←
83	→	←	←	←
P21, P22	DW	W	DW	DRK
P81, P82	DW	DW	W	DRK

SE-PAC 2070 LOOP & DETECTOR UNIT INSTALLATION CHART

LOOP NO.	SIZE (ft)	TURNS	DIST. FROM STOPBAR (ft)	NEW	EXISTING	ASSIGNED PHASE	TIMING		DETECTOR PROGRAMMING										STATUS					
							DELAY	EXTEND (STRETCH)	OPERATION MODE															
									VEHICLE	PEDESTRIAN	1 CALL	2	3	4	5	6	7	8		9	10	11	12	SWITCH
1A	6X40	2-4-2	0	X	-	1	5 SEC.	- SEC.	X	-	-	-	-	-	-	-	-	-	-	-	-	-	X	-
1B	6X40	2-4-2	0	X	-	1	15 SEC.	- SEC.	X	-	-	-	-	-	-	-	-	-	-	-	-	-	X	-
2A	6X6	4	300	X	-	2	- SEC.	- SEC.	X	-	-	-	-	-	-	-	-	-	-	-	-	-	X	-
2B	6X6	4	300	X	-	2	- SEC.	- SEC.	X	-	-	-	-	-	-	-	-	-	-	-	-	-	X	-
2C	6X6	4	300	X	-	2	- SEC.	- SEC.	X	-	-	-	-	-	-	-	-	-	-	-	-	-	X	-
6A	6X6	4	300	X	-	6	- SEC.	- SEC.	X	-	-	-	-	-	-	-	-	-	-	-	-	-	X	-
6B	6X6	4	300	X	-	6	- SEC.	- SEC.	X	-	-	-	-	-	-	-	-	-	-	-	-	-	X	-
6C	6X6	4	300	X	-	6	- SEC.	- SEC.	X	-	-	-	-	-	-	-	-	-	-	-	-	-	X	-
8A	6X40	2-4-2	0	X	-	8	3 SEC.	- SEC.	X	-	-	-	-	-	-	-	-	-	-	-	-	-	X	-
8B	6X40	2-4-2	0	X	-	8	- SEC.	- SEC.	X	-	-	-	-	-	-	-	-	-	-	-	-	-	X	-

SIGNAL FACE I.D.

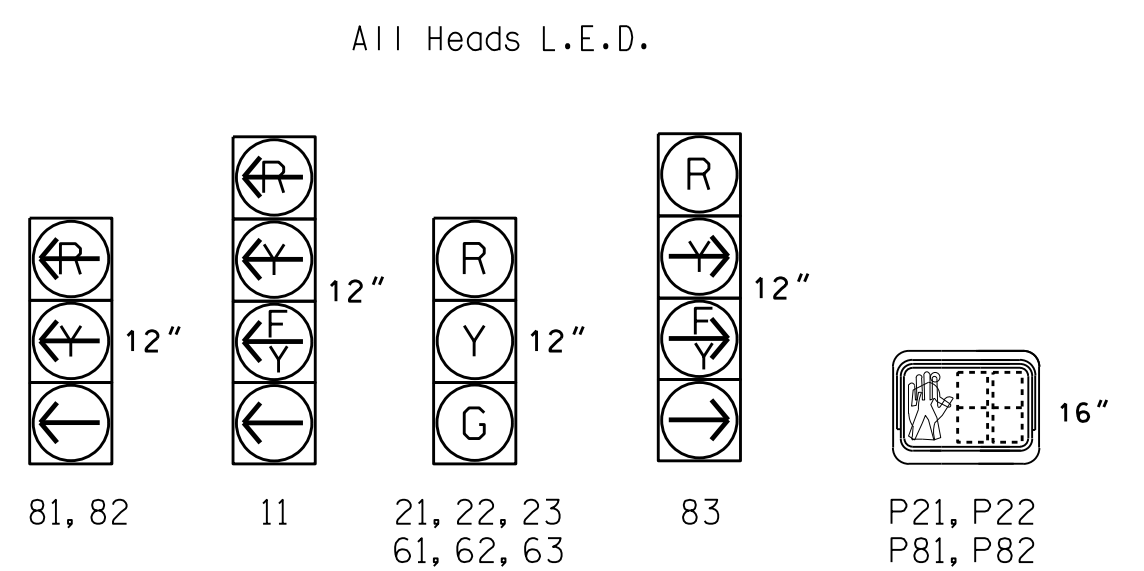

3 Phase Fully Actuated (Raleigh Signal System)

NOTES

- Refer to "Roadway Standard Drawings NCDOT" dated January 2018 and "Standard Specifications for Roads and Structures" dated January 2018.
- Do not program signal for late night flashing operation unless otherwise directed by the Engineer.
- Phase 1 may be lagged.
- Set all detector units to presence mode.
- Omit "WALK" and flashing "DON'T WALK" with no pedestrian calls.
- Program pedestrian heads to countdown the flashing "Don't Walk" time only.
- The Division (City) Traffic Engineer will determine the hours of use for each phasing plan.
- Maximum times shown in timing chart are for free-run operation only. Coordinated signal system timing values supersede these values.
- Program phase 4 as a dummy phase for Ring 1.
- This intersection features accessible pedestrian signals utilizing percussive tone walk indications and/or speech messages.

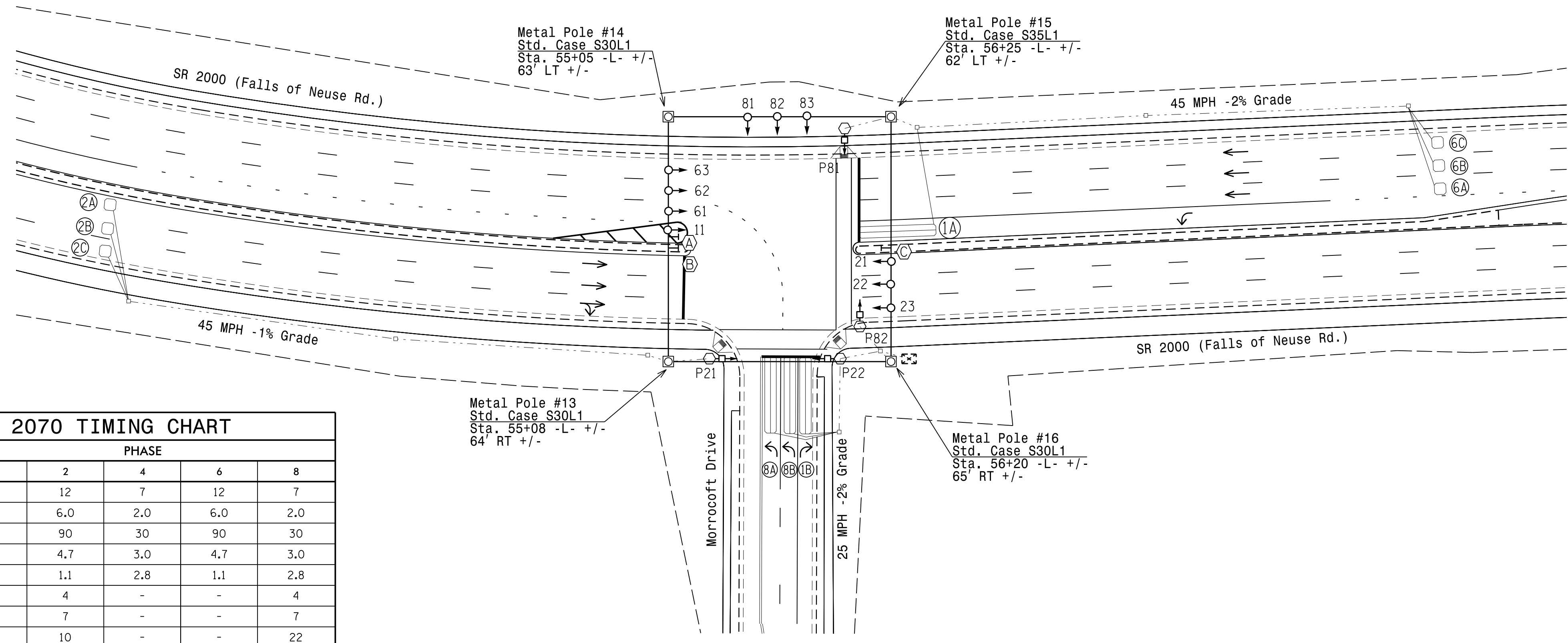

SE-PAC 2070 TIMING CHART

FEATURE	PHASE				
	1	2	4	6	8
Min Green *	7	12	7	12	7
Passage Gap *	2.0	6.0	2.0	6.0	2.0
Maximum Green *	15	90	30	90	30
Yellow Change	3.0	4.7	3.0	4.7	3.0
Red Clear	2.8	1.1	2.8	1.1	2.8
Advance Walk *	-	4	-	-	4
Walk *	-	7	-	-	7
Pedestrian Clear	-	10	-	-	22
Added Initial *	-	1.0	-	1.0	-
Maximum Initial *	-	34	-	34	-
Time Before Reduction *	-	15	-	15	-
Time To Reduce *	-	30	-	30	-
Minimum Gap	-	3.0	-	3.0	-
Recall Mode	-	MIN RECALL	-	MIN RECALL	-
Vehicle Call Memory	NON-LOCK	LOCK	-	LOCK	NON-LOCK
Dual Entry	-	-	-	-	-
Simultaneous Gap	ON	ON	ON	ON	ON

ACCESSIBLE PEDESTRIAN SIGNAL OPERATION

SIGNAL FACE	VOICE	TONES	INTERVAL	SPEECH MESSAGE
P21, P22	-	X	Walk	(Percussive Tone)
	X	-	Flashing Don't Walk / Don't Walk	Wait. Wait to cross Morrocoff.
P81, P82	-	X	Walk	(Percussive Tone)
	X	-	Flashing Don't Walk / Don't Walk	Wait. Wait to cross Falls of Neuse.

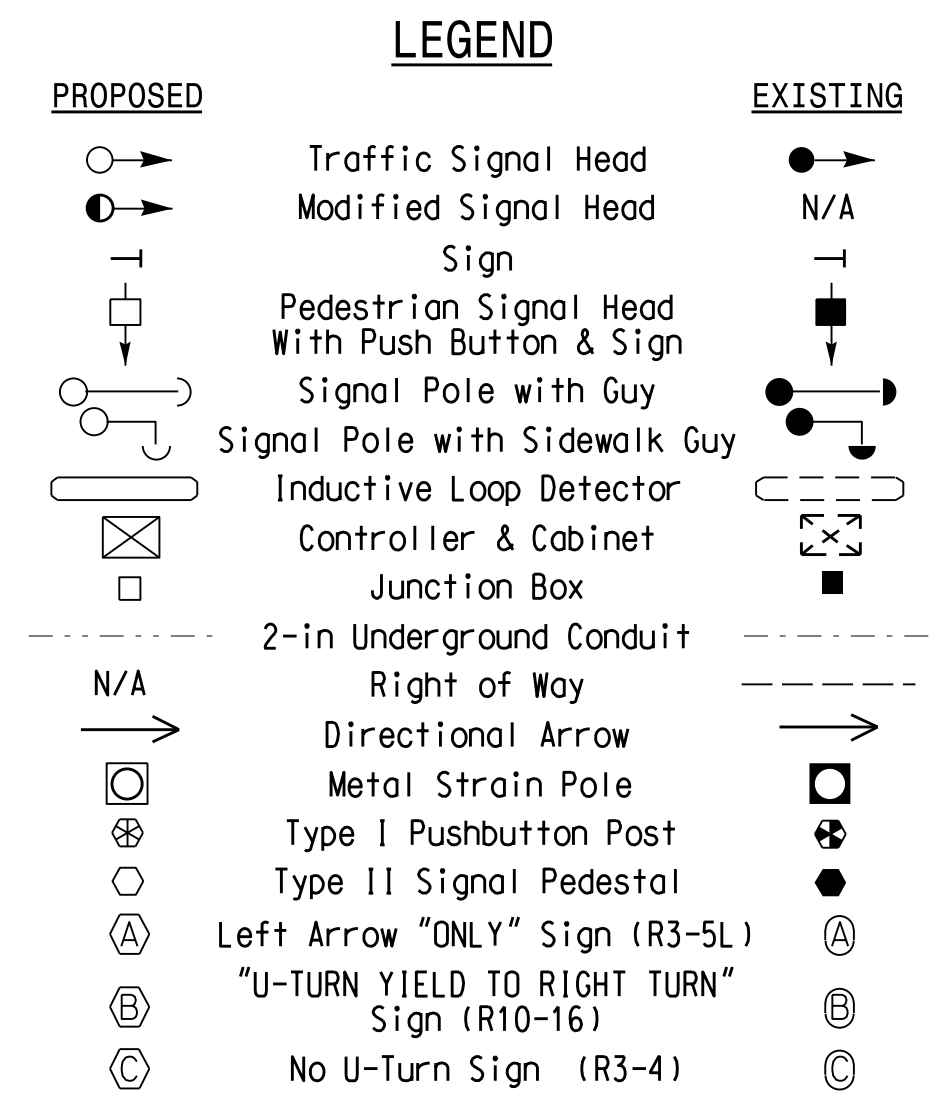

Signal Upgrade - Final Design

SR 2000 (Falls of Neuse Rd.) at Morrocoff Drive

Division 5 Wake County Raleigh

PLAN DATE: January 2023 REVIEWED BY:

PREPARED BY: I. O. Umozurike REVIEWED BY:

750 N. Greenfield Pkwy, Garner, NC 27529

SCALE 0 40 1"=40'

REVISIONS

NO.	DATE	INIT.	DATE

DOCUMENT NOT CONSIDERED FINAL UNLESS ALL SIGNATURES COMPLETED

SEAL

ROBERT J. TITMUS

01/03/2023

SIG. INVENTORY NO. 05-2293

13-APR-2023 09:37
 S:\IT\GIS\UM\15\Sigmal\Signal Design\Central Region\401.v 5\U-5826\05-2293.WP#052293.s\p.dgn, 2023mod.dgn
 JAL:ort

* These values may be field adjusted. Do not adjust Min Green and Extension times for phases 2 and 6 lower than what is shown. Min Green for all other phases should not be lower than 4 seconds.