

09/08/09

TIP PROJECT: BR-0073

CONTRACT: C204795

See Sheet 1A For Index of Sheets

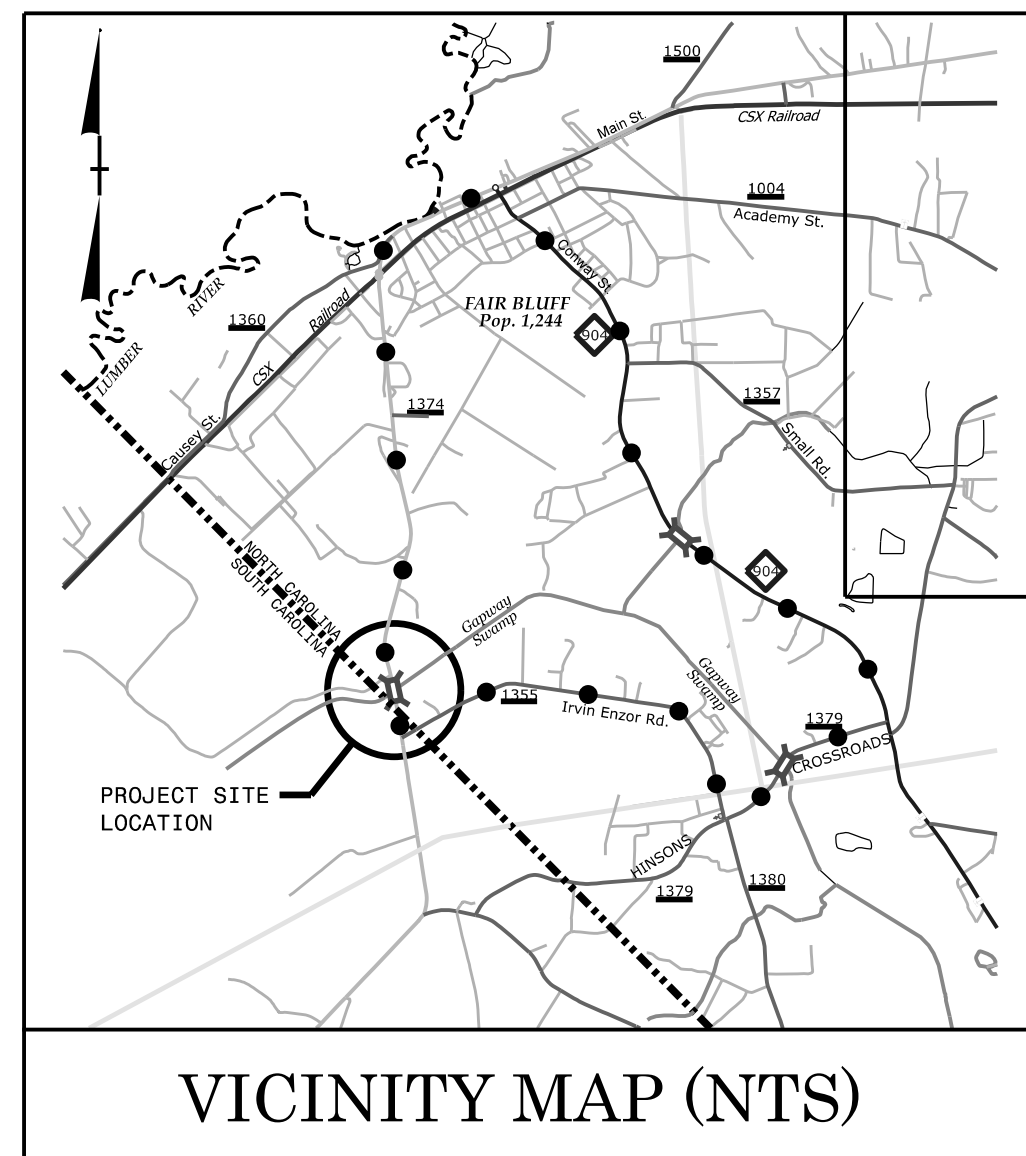

# STATE OF NORTH CAROLINA DIVISION OF HIGHWAYS

## PLAN FOR PROPOSED HIGHWAY EROSION CONTROL

### COLUMBUS COUNTY

LOCATION: *BRIDGE NO. 230005 ON US 76 OVER GAPWAY SWAMP*  
TYPE OF WORK: *GRADING, DRAINAGE, PAVING, & STRUCTURE*

STATE	STATE PROJECT REFERENCE NO.	SHEET NO.	TOTAL SHEETS
N.C.	BR-0073	EC-1	
STATE PROJ. NO.	F. A. PROJ. NO.	DESCRIPTION	

#### EROSION AND SEDIMENT CONTROL MEASURES

Std. #	Description	Symbol
1630.03	Temporary Silt Ditch	
1630.05	Temporary Diversion	
1605.01	Temporary Silt Fence	
1606.01	Special Sediment Control Fence	
1622.01	Temporary Berms and Slope Drains	
1630.02	Silt Basin Type B	
1633.01	Temporary Rock Silt Check Type-A	
	Temporary Rock Silt Check Type-A with Matting and Polyacrylamide (PAM)	
1633.02	Temporary Rock Silt Check Type-B	
	Wattle / Coir Fiber Wattle	
	Wattle / Coir Fiber Wattle with Polyacrylamide (PAM)	
1634.01	Temporary Rock Sediment Dam Type-A	
1634.02	Temporary Rock Sediment Dam Type-B	
1635.01	Rock Pipe Inlet Sediment Trap Type-A	
1635.02	Rock Pipe Inlet Sediment Trap Type-B	
1630.04	Stilling Basin	
1630.06	Special Stilling Basin	
	Rock Inlet Sediment Trap:	
1632.01	Type A	
1632.02	Type B	
1632.03	Type C	
	Skimmer Basin	
	Tiered Skimmer Basin	
	Infiltration Basin	

**THIS PROJECT CONTAINS  
EROSION CONTROL PLANS  
FOR CLEARING AND  
GRUBBING PHASE OF  
CONSTRUCTION.**

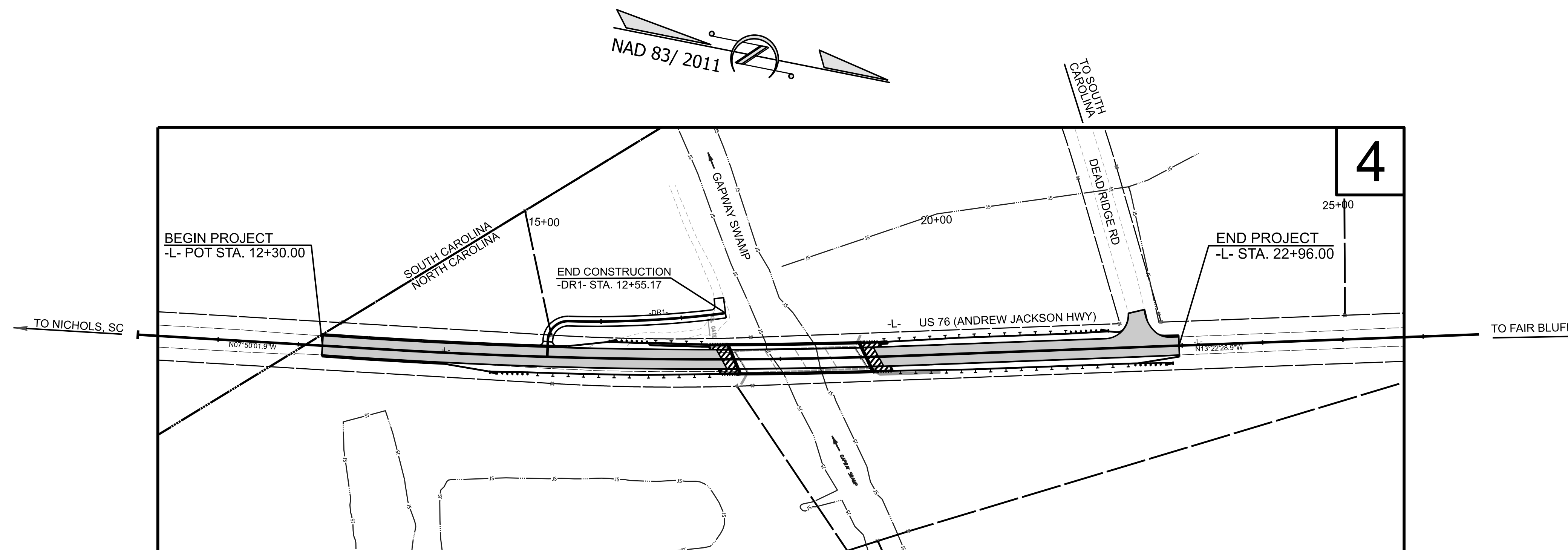

#### GRAPHIC SCALES

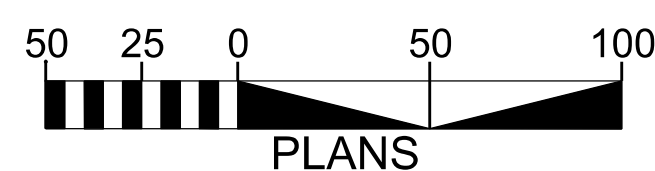

THESE EROSION AND SEDIMENT CONTROL PLANS COMPLY WITH THE APPLICABLE REGULATIONS SET FORTH BY THE NCG-010000 GENERAL CONSTRUCTION PERMIT EFFECTIVE APRIL 1, 2019 AND ISSUED BY THE NORTH CAROLINA DEPARTMENT OF ENVIRONMENTAL QUALITY DIVISION OF WATER RESOURCES.

Prepared in the Office of:



434 FAYETTEVILLE ST. #1500  
RALEIGH, NC 27601  
NC ENG F-1253

Designed by:

**EKENE OKORIE, EI** 4452  
NAME LEVEL III CERTIFICATION NO.

#### Roadway Standard Drawings

The following roadway english standards as appear in "Roadway Standard Drawings"- Roadway Design Unit - N. C. Department of Transportation - Raleigh, N. C., dated January 2018 and the latest revision thereto are applicable to this project and by reference hereby are considered a part of these plans.

1604.01 Railroad Erosion Control Detail	1632.01 Rock Inlet Sediment Trap Type A
1605.01 Temporary Silt Fence	1632.02 Rock Inlet Sediment Trap Type B
1606.01 Special Sediment Control Fence	1632.03 Rock Inlet Sediment Trap Type C
1607.01 Gravel Construction Entrance	1633.01 Temporary Rock Silt Check Type A
1622.01 Temporary Berms and Slope Drains	1633.02 Temporary Rock Silt Check Type B
1630.01 Riser Basin	1634.01 Temporary Rock Sediment Dam Type A
1630.02 Silt Basin Type B	1634.02 Temporary Rock Sediment Dam Type B
1630.03 Temporary Silt Ditch	1635.01 Rock Pipe Inlet Sediment Trap Type A
1630.04 Stilling Basin	1635.02 Rock Pipe Inlet Sediment Trap Type B
1630.05 Temporary Diversion	1640.01 Coir Fiber Wattle
1630.06 Special Stilling Basin	1645.01 Temporary Stream Crossing
1631.01 Matting Installation	

# COIR FIBER WATTLE WITH POLYACRYLAMIDE (PAM) DETAIL

### NOTES:

USE MINIMUM 12 IN. DIAMETER COIR FIBER (COCONUT FIBER) WATTLE.

USE 2 FT. WOODEN STAKES WITH A 2 IN. BY 2 IN. NOMINAL CROSS SECTION.

ONLY INSTALL WATTLE(S) TO A HEIGHT IN DITCH SO FLOW WILL NOT WASH AROUND WATTLE AND SCOUR DITCH SLOPES AND AS DIRECTED.

INSTALL A MINIMUM OF 2 UPSLOPE STAKES AND 4 DOWNSLOPE STAKES AT AN ANGLE TO WEDGE WATTLE TO BOTTOM OF DITCH.

PROVIDE STAPLES MADE OF 0.125 IN. DIAMETER STEEL WIRE FORMED INTO A U SHAPE NOT LESS THAN 12" IN LENGTH.

INSTALL STAPLES APPROXIMATELY EVERY 1 LINEAR FOOT ON BOTH SIDES OF WATTLE AND AT EACH END TO SECURE IT TO THE SOIL.

INSTALL MATTING IN ACCORDANCE WITH SECTION 1631 OF THE STANDARD SPECIFICATIONS.

PRIOR TO POLYACRYLAMIDE (PAM) APPLICATION, OBTAIN A SOIL SAMPLE FROM PROJECT LOCATION, AND FROM OFFSITE MATERIAL, AND ANALYZE FOR APPROPRIATE PAM FLOCCULANT TO BE APPLIED TO EACH WATTLE.

INITIALLY APPLY 2 OUNCES OF ANIONIC OR NEUTRALLY CHARGED PAM OVER WATTLE WHERE WATER WILL FLOW AND 1 OUNCE OF PAM ON MATTING ON EACH SIDE OF WATTLE. REAPPLY PAM AFTER EVERY RAINFALL EVENT THAT IS EQUAL TO OR EXCEEDS 0.50 IN.

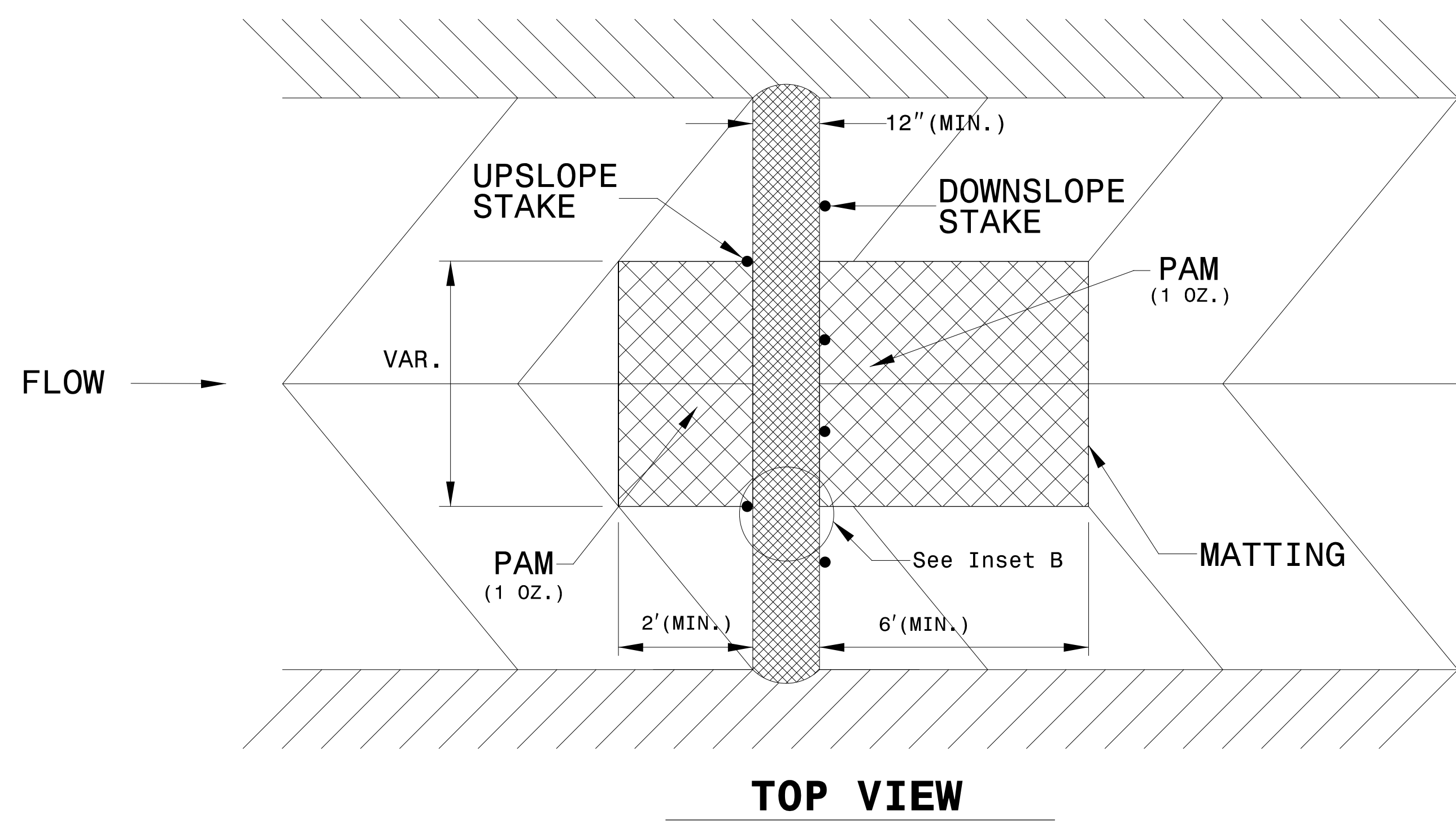
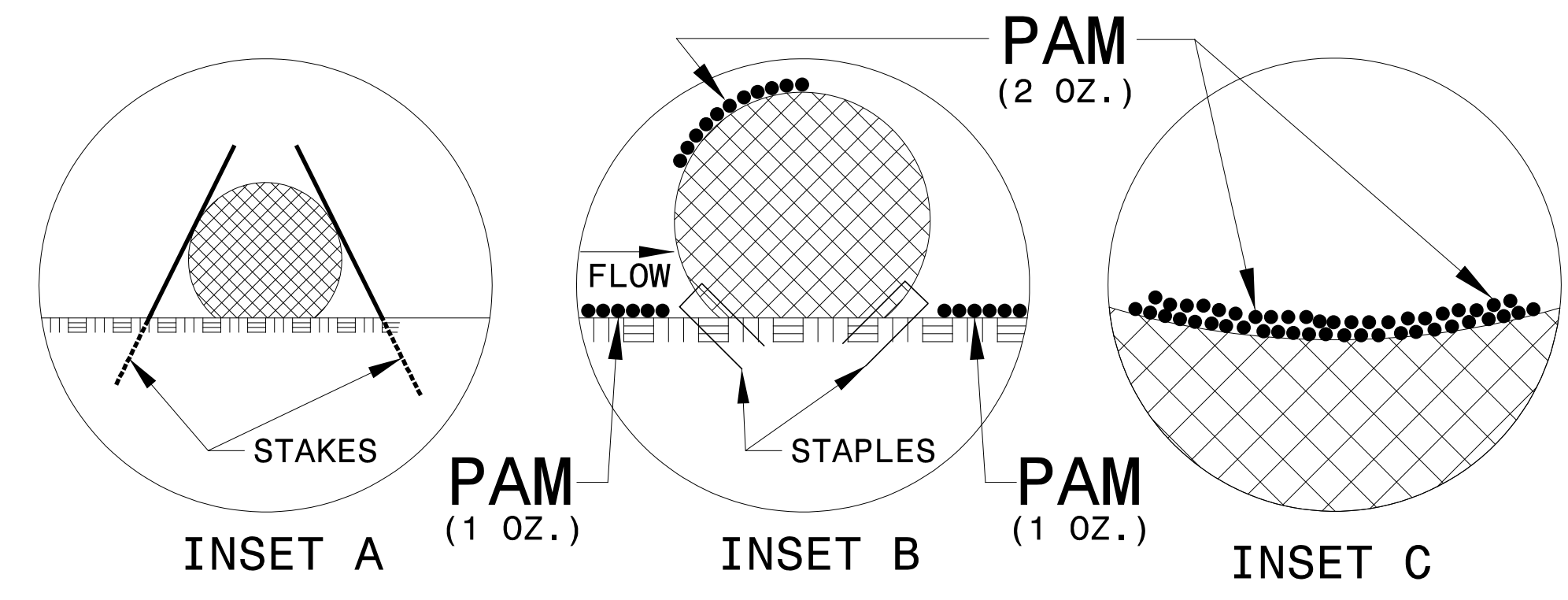
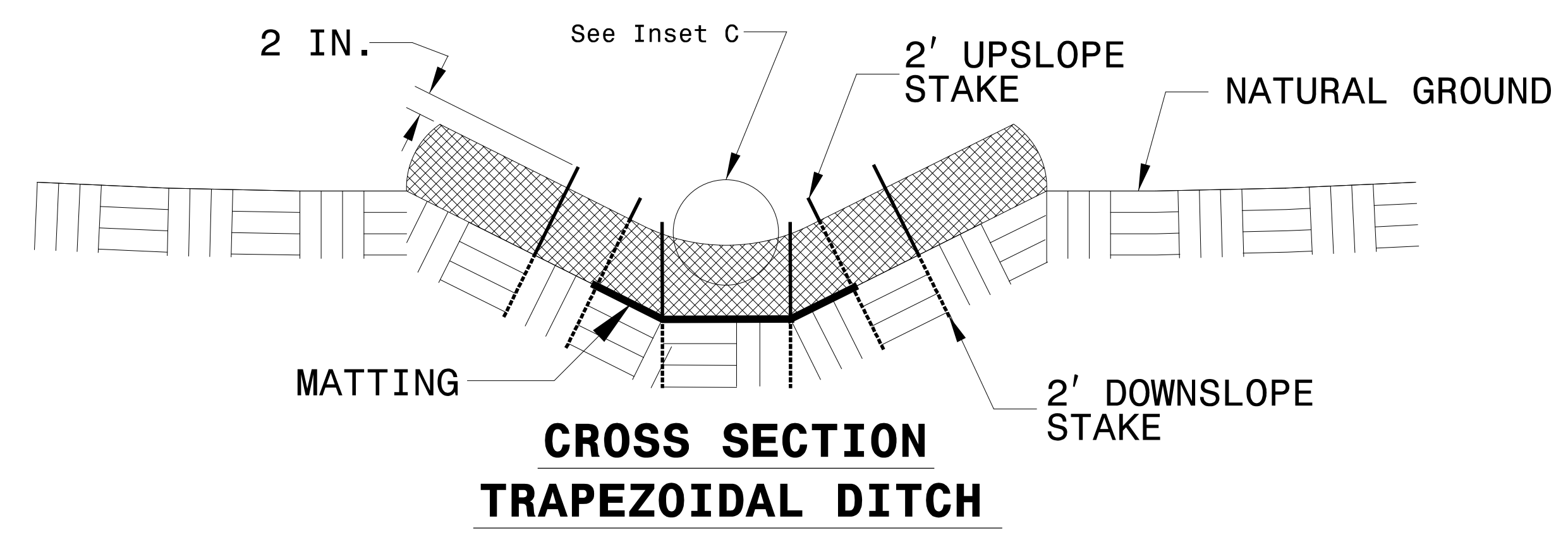
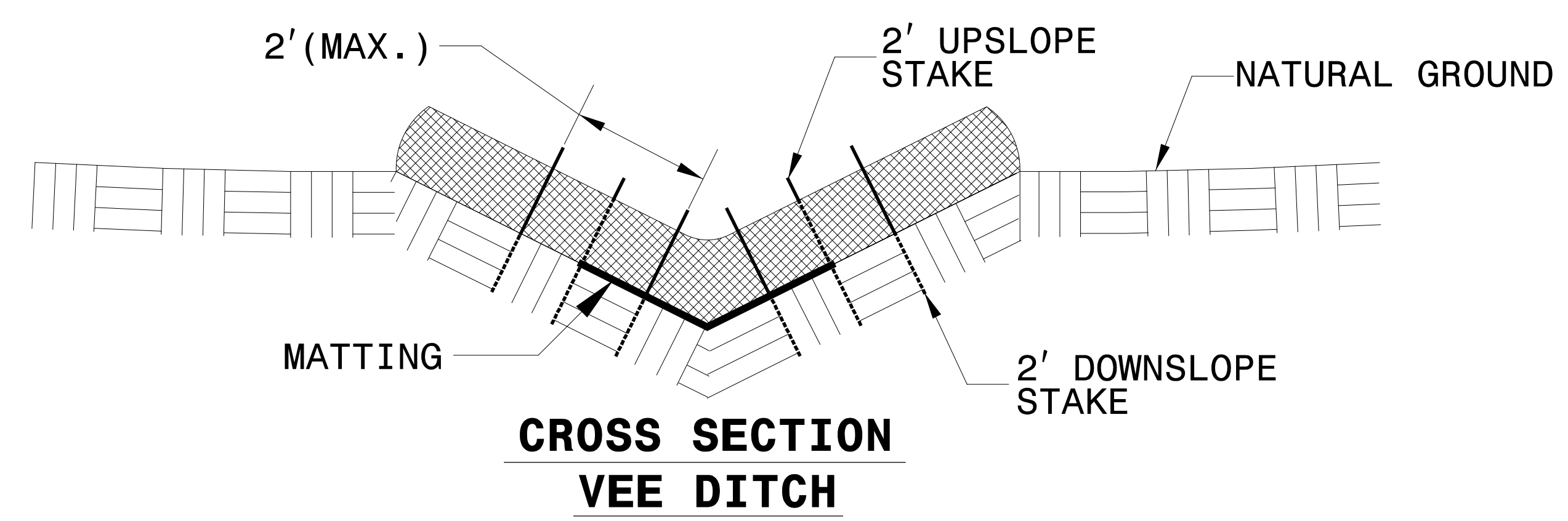
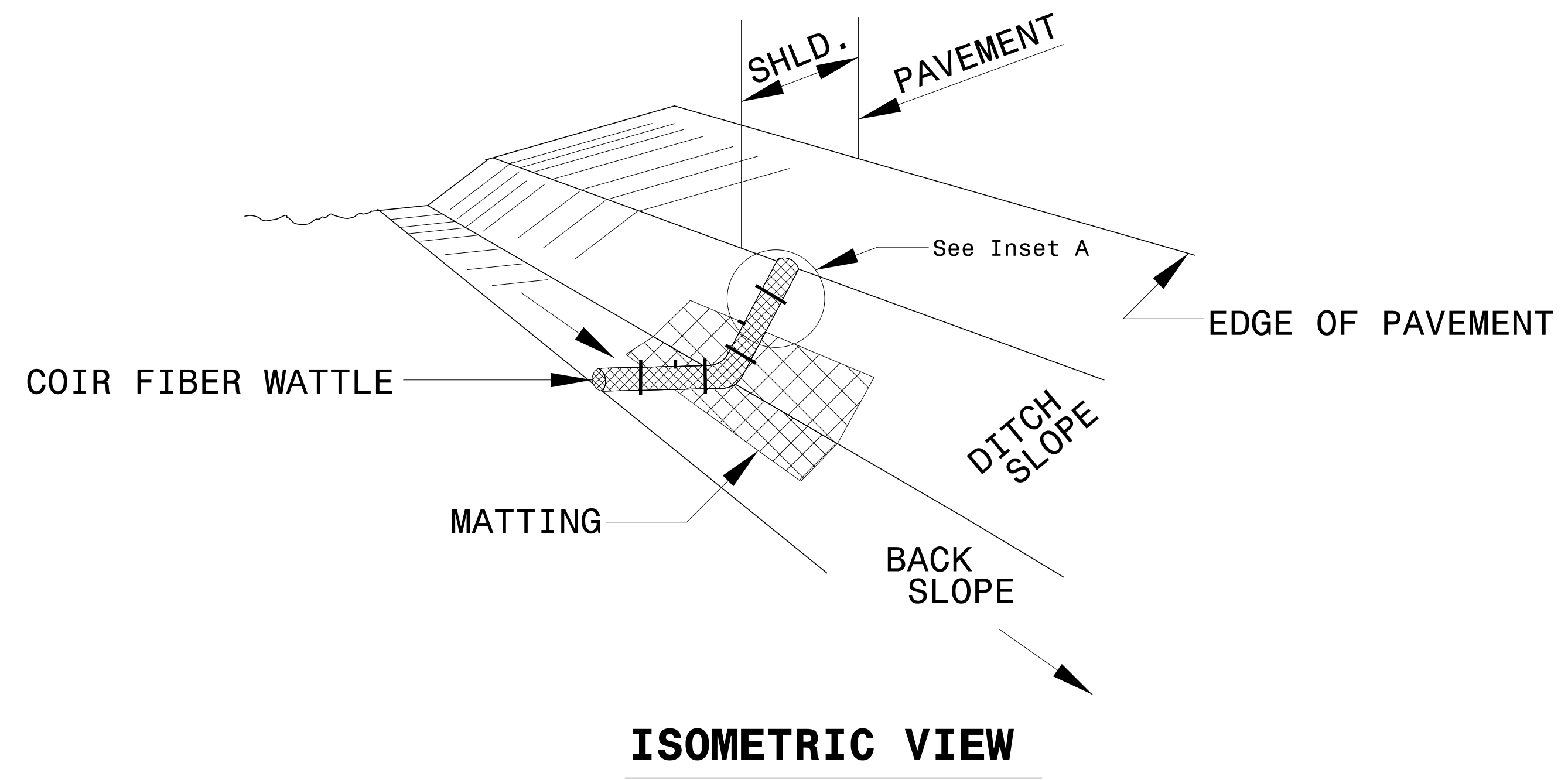

5/26/20

# SILT FENCE COIR FIBER WATTLE BREAK DETAIL

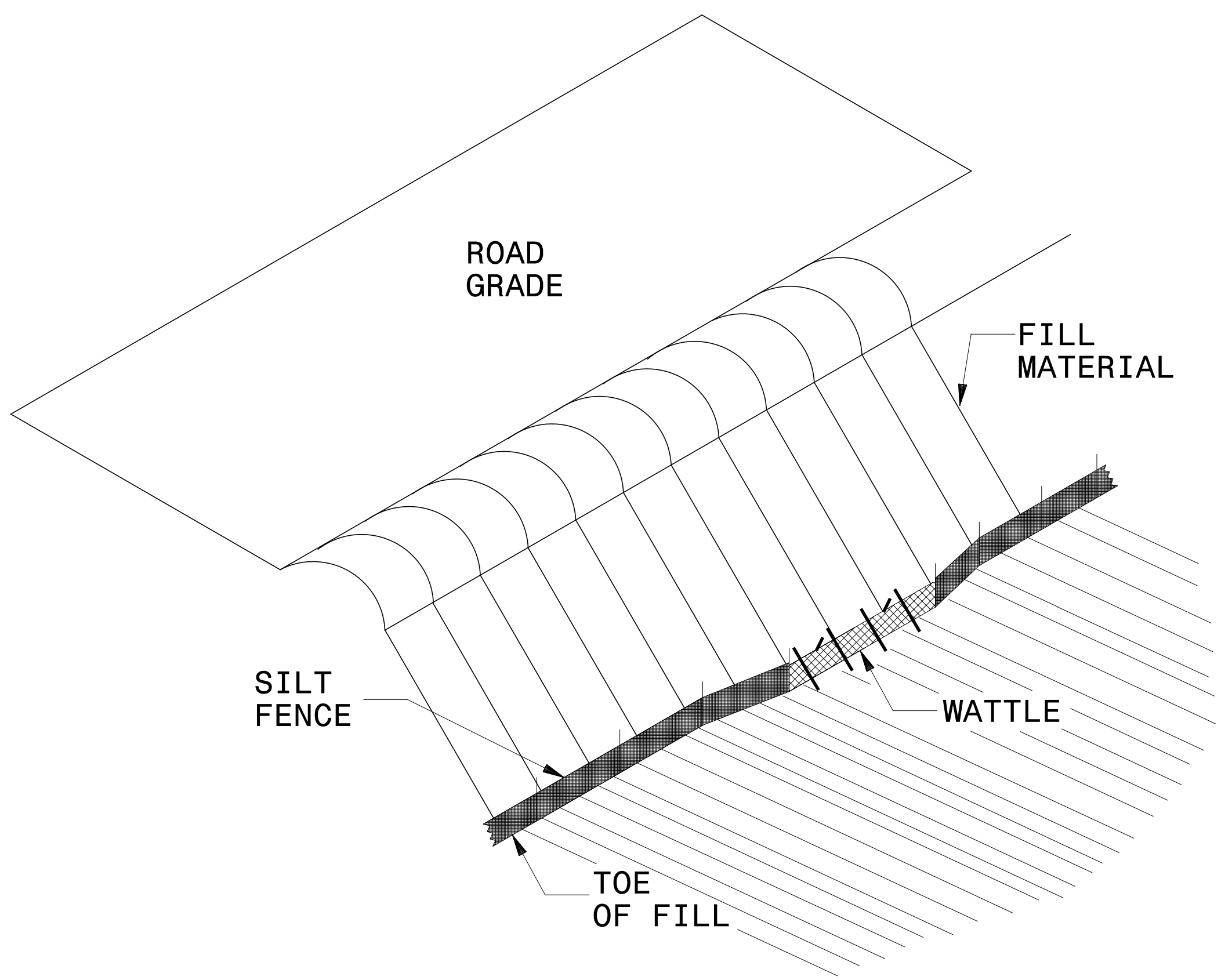

**ISOMETRIC VIEW**

**NOTES:**

- USE MINIMUM 12 IN. DIAMETER COIR FIBER (COCONUT FIBER) WATTLE AND LENGTH OF 10 FT.
- EXCAVATE A 1 TO 2 INCH TRENCH FOR WATTLE TO BE PLACED.
- DO NOT PLACE WATTLE ON TOE OF SLOPE.
- USE 2 FT. WOODEN STAKES WITH A 2 IN. BY 2 IN. NOMINAL CROSS SECTION.
- INSTALL A MINIMUM OF 2 UPSLOPE STAKES AND 4 DOWNSLOPE STAKES AT AN ANGLE TO WEDGE WATTLE TO GROUND.
- PROVIDE STAPLES MADE OF 0.125 IN. DIAMETER STEEL WIRE FORMED INTO A U SHAPE NOT LESS THAN 12" IN LENGTH.
- INSTALL STAPLES APPROXIMATELY EVERY 1 LINEAR FOOT ON BOTH SIDES OF WATTLE AND AT EACH END TO SECURE IT TO THE SOIL.
- WATTLE INSTALLATION CAN BE ON OUTSIDE OF THE SILT FENCE AS DIRECTED.
- INSTALL TEMPORARY SILT FENCE IN ACCORDANCE WITH SECTION 1605 OF THE STANDARD SPECIFICATIONS.

**INSET A**

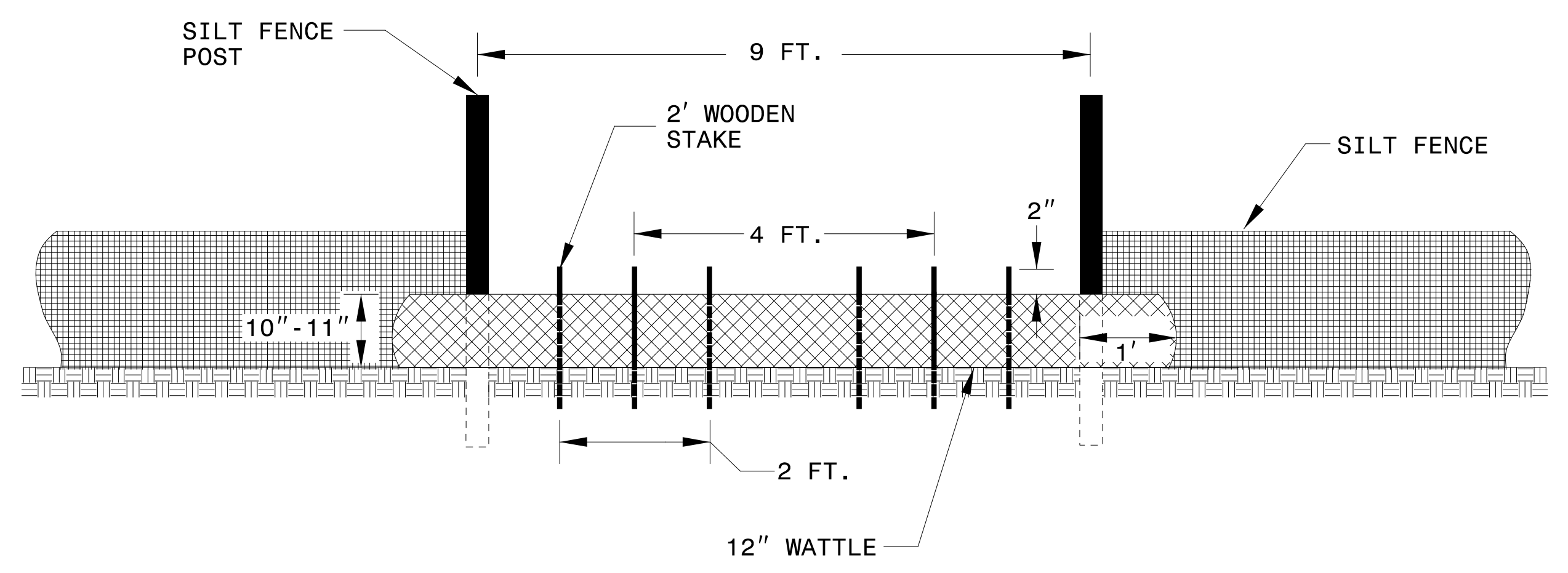
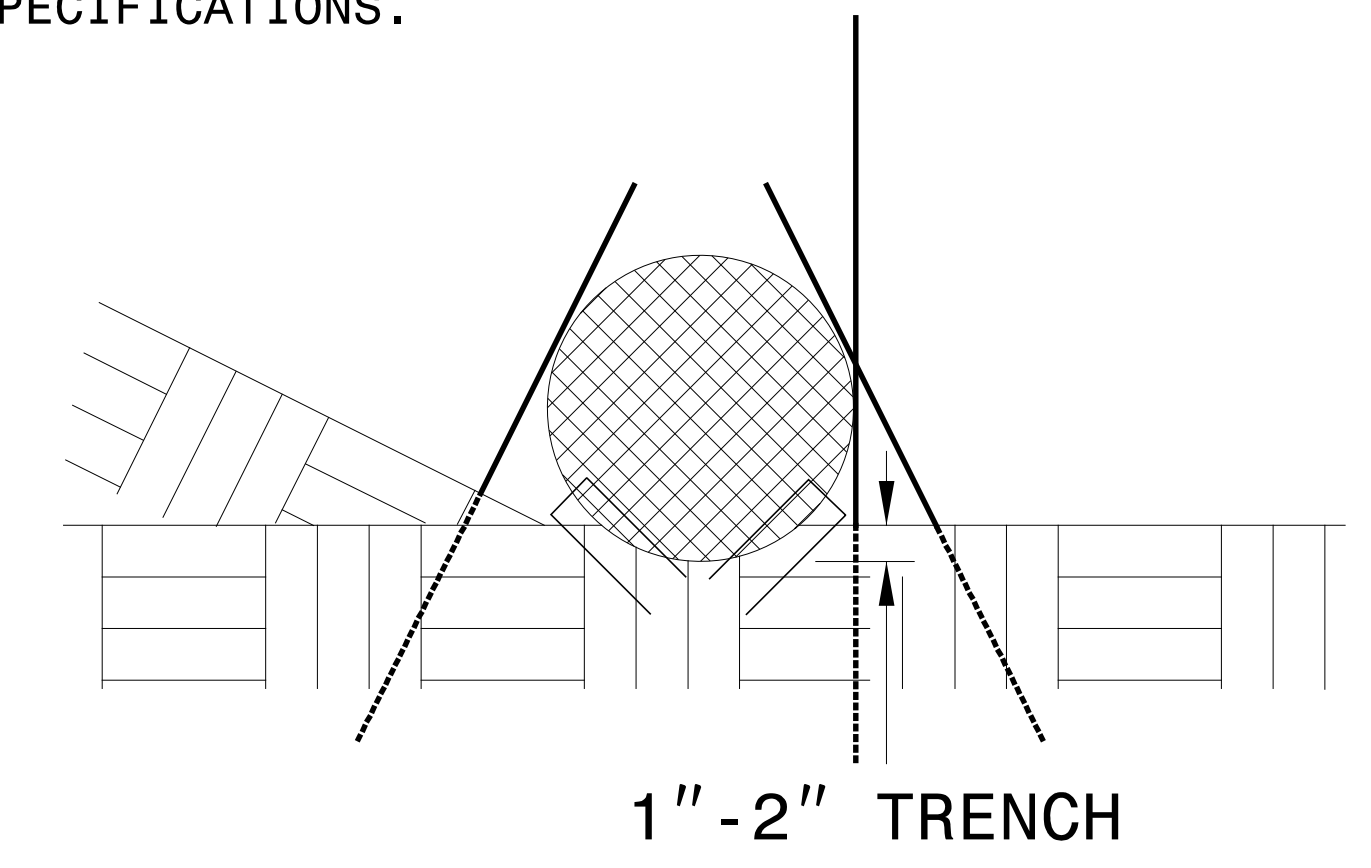

**VIEW FROM SLOPE**

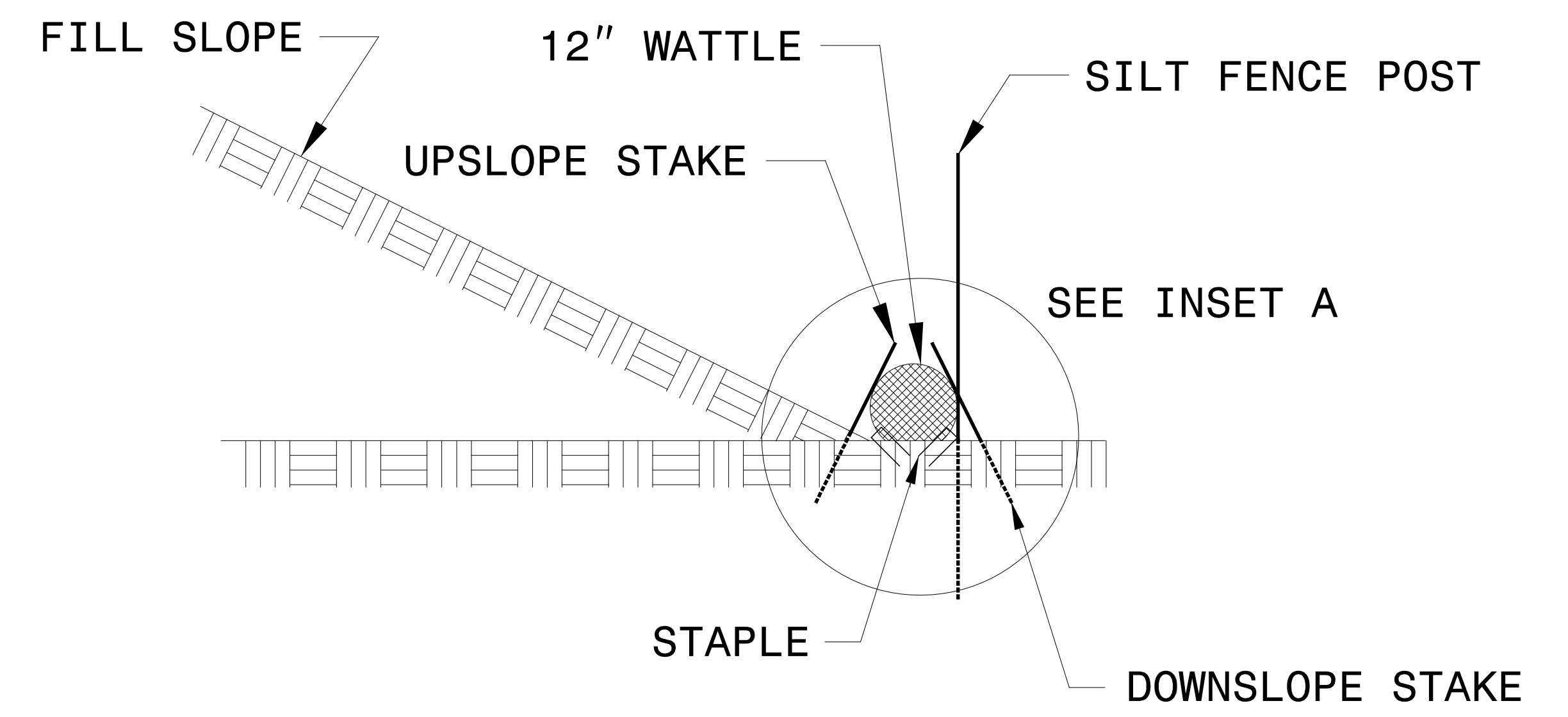

**SIDE VIEW**

# COIR FIBER WATTLE BARRIER DETAIL

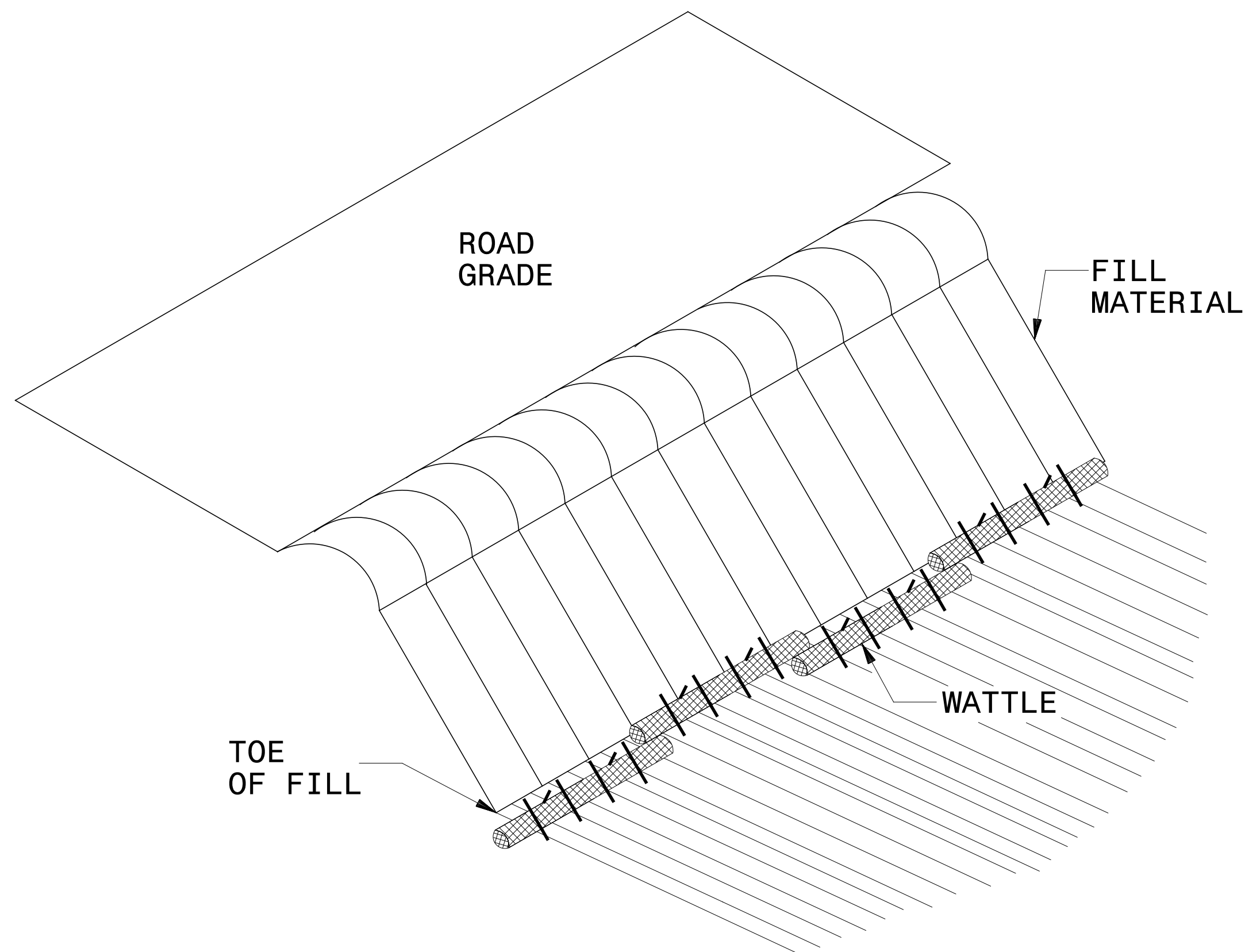

**ISOMETRIC VIEW**

**NOTES:**

USE MINIMUM 18 IN. NOMINAL DIAMETER COIR FIBER (COCONUT) WATTLE AND LENGTH OF 10 FT.

EXCAVATE A 2 TO 3 INCH TRENCH FOR WATTLE TO BE PLACED.

DO NOT PLACE WATTLES ON TOE OF SLOPE.

USE 2 FT. WOODEN STAKES WITH A 2 IN. BY 2 IN. NOMINAL CROSS SECTION.

INSTALL A MINIMUM OF 2 UPSLOPE STAKES AND 4 DOWNSLOPE STAKES AT AN ANGLE TO WEDGE WATTLE TO GROUND.

PROVIDE STAPLES MADE OF 0.125 IN. DIAMETER STEEL WIRE FORMED INTO A U SHAPE NOT LESS THAN 12" IN LENGTH.

INSTALL STAPLES APPROXIMATELY EVERY 1 LINEAR FOOT ON BOTH SIDES OF WATTLE AND AT EACH END TO SECURE IT TO THE SOIL.

FOR BREAKS ALONG LARGE SLOPES, USE MAXIMUM SPACING OF 25 FT.

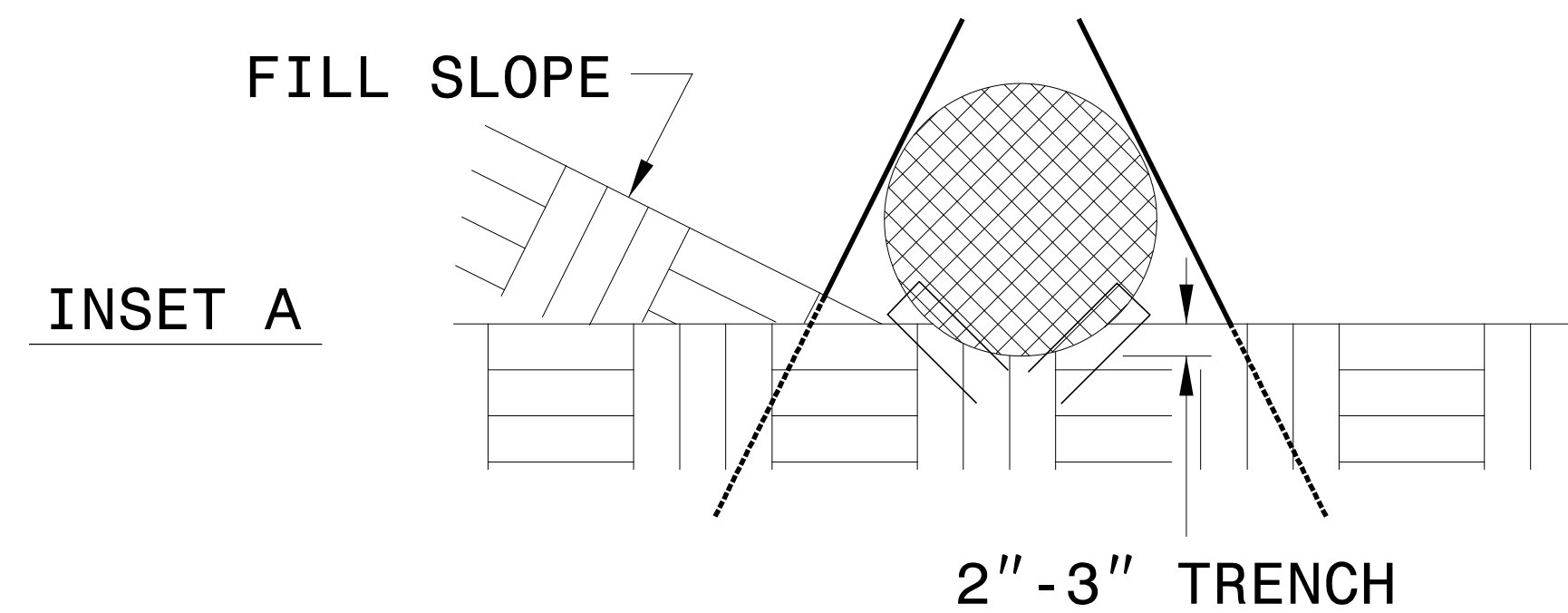

**INSET A**

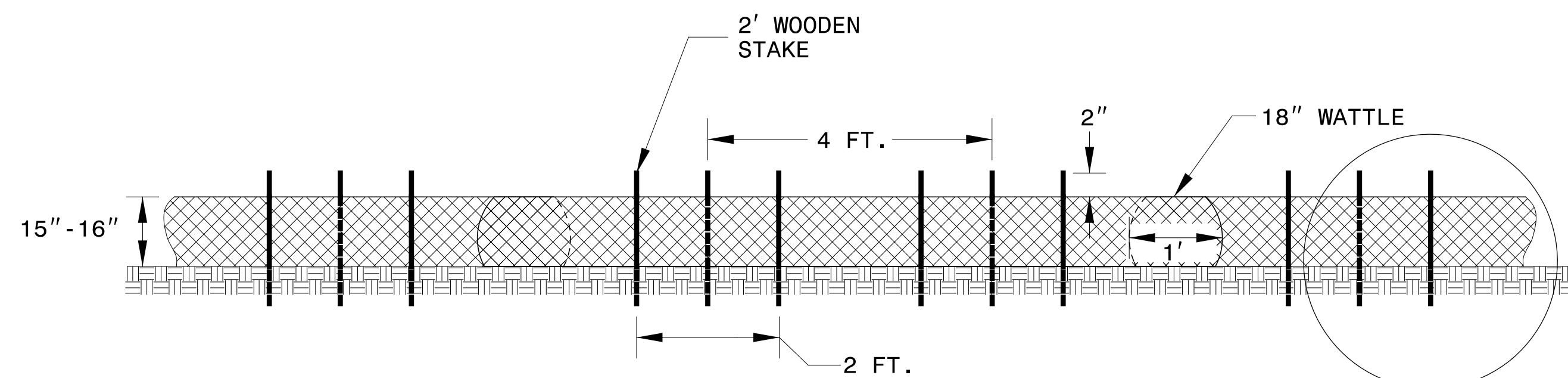

**FRONT VIEW**

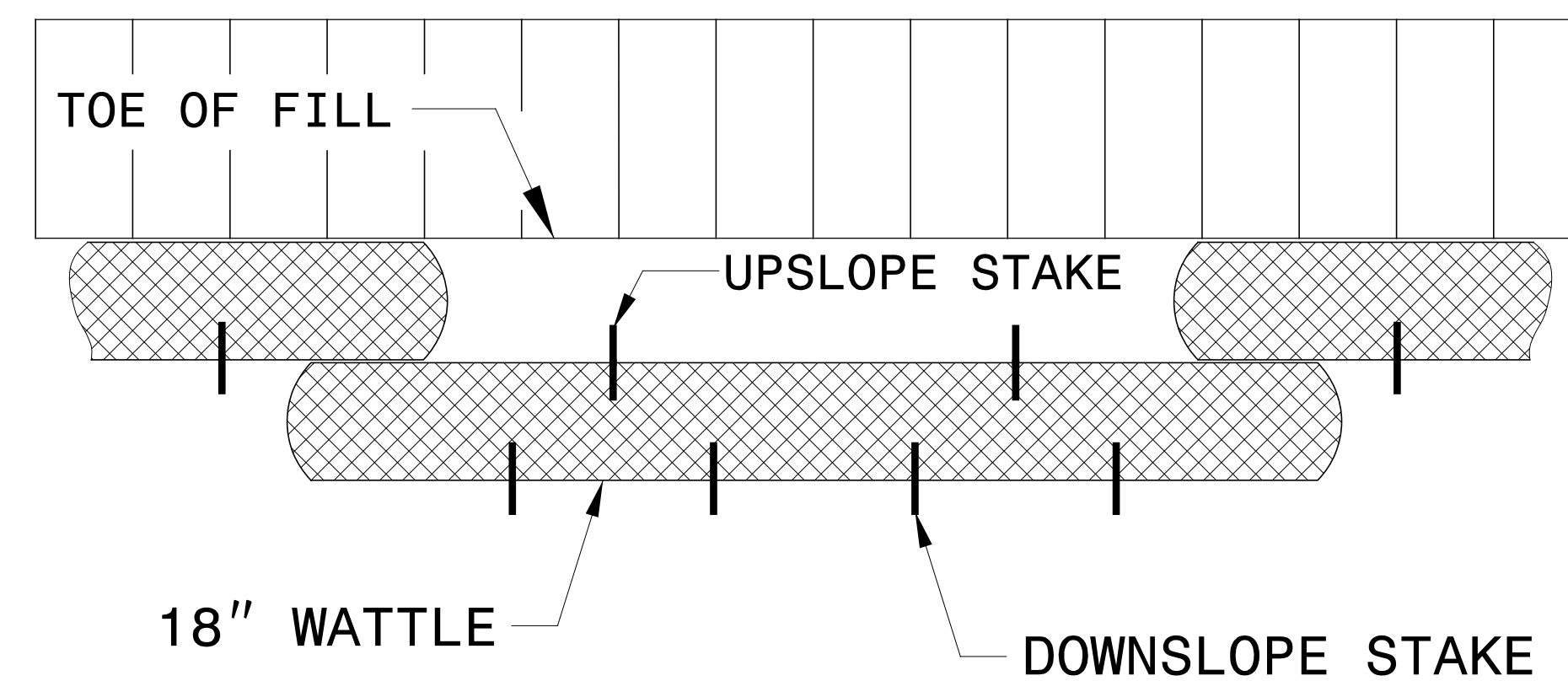

**TOP VIEW**

DIVISION OF HIGHWAYS  
STATE OF NORTH CAROLINA

---



---

## ***SOIL STABILIZATION TIMEFRAMES***

<i>SITE DESCRIPTION</i>	<i>STABILIZATION TIME</i>	<i>TIMEFRAME EXCEPTIONS</i>
PERIMETER DIKES, SWALES, DITCHES AND SLOPES	7 DAYS	NONE
HIGH QUALITY WATER (HQW) ZONES	7 DAYS	NONE
SLOPES STEEPER THAN 3:1	7 DAYS	IF SLOPES ARE 10' OR LESS IN LENGTH AND ARE NOT STEEPER THAN 2:1, 14 DAYS ARE ALLOWED.
SLOPES 3:1 OR FLATTER	14 DAYS	7 DAYS FOR SLOPES GREATER THAN 50' IN LENGTH.
ALL OTHER AREAS WITH SLOPES FLATTER THAN 4:1	14 DAYS	NONE, EXCEPT FOR PERIMETERS AND HQW ZONES.

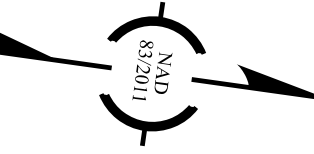

CLEARING AND GRUBBING  
EROSION CONTROL FOR  
CONSTRUCTION SHEET 4

NOTE:  
IMPERVIOUS DIKES MAY BE MODIFIED AND/OR  
ELIMINATED AS DIRECTED.

NOTE:  
PERIMETER EROSION CONTROL MEASURES SHALL BE  
INSTALLED DURING CLEARING AND GRUBBING PHASE.

NOTE:  
UTILIZE SPECIAL STILLING BASIN TO  
DEWATER WORK SITE AS DIRECTED.

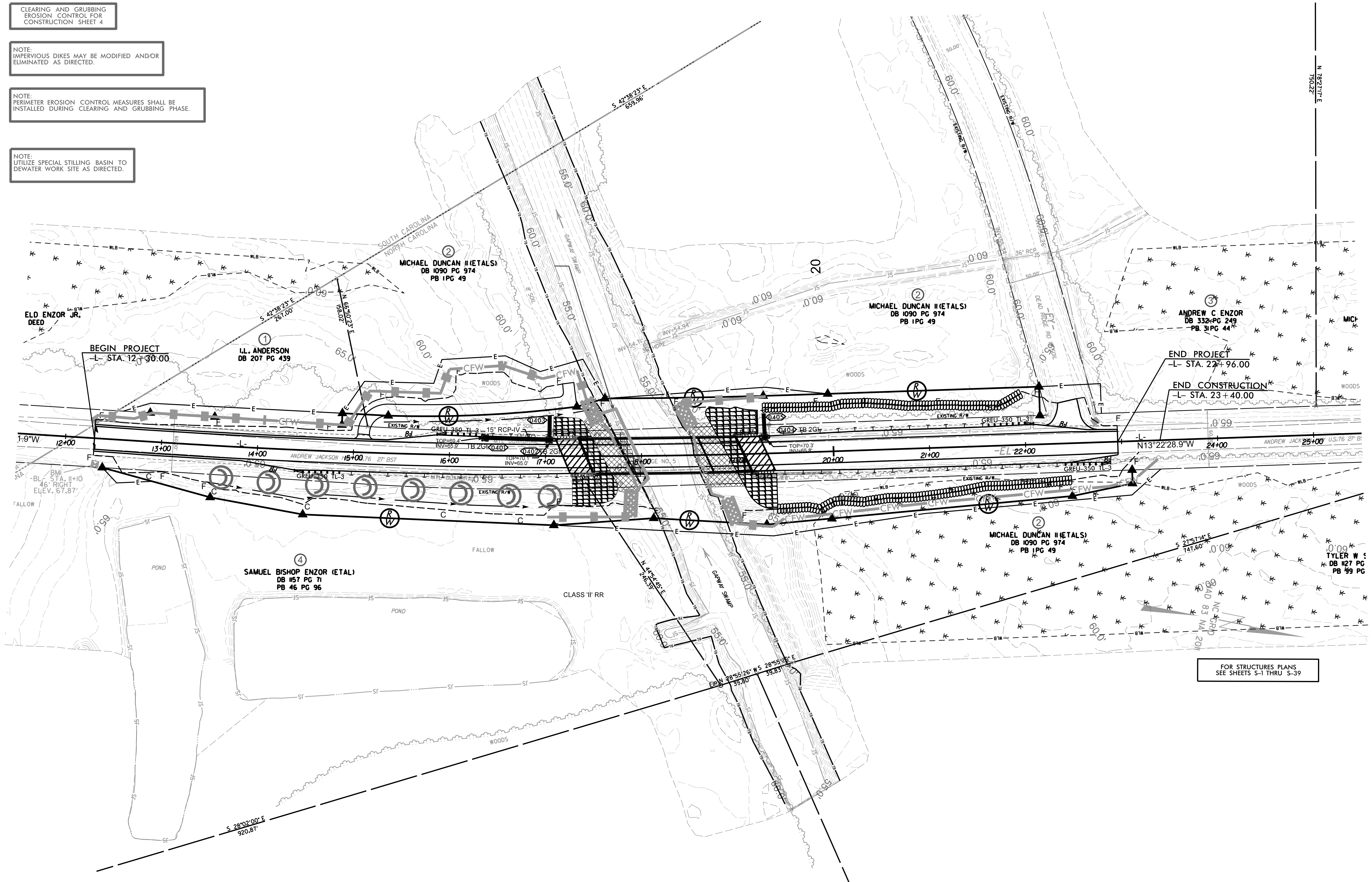

FOR STRUCTURES PLANS  
SEE SHEETS S-1 THRU S-39

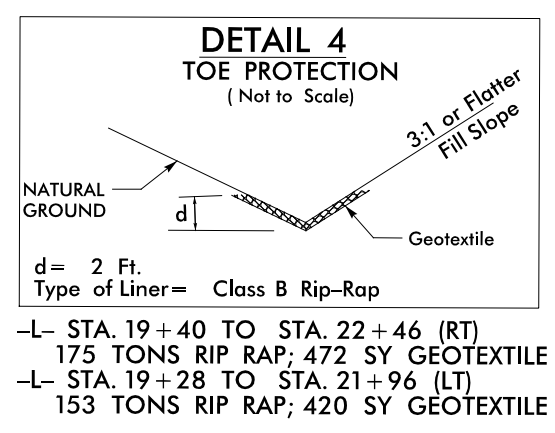
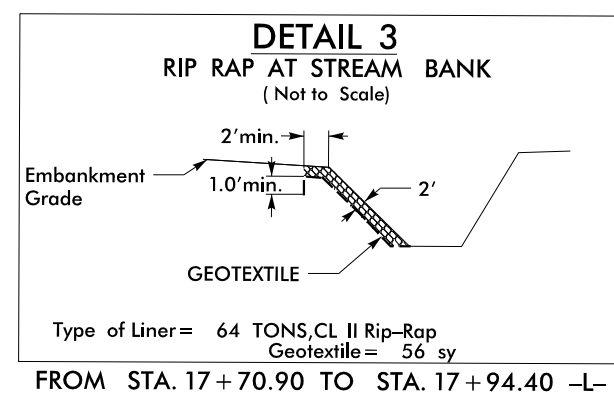
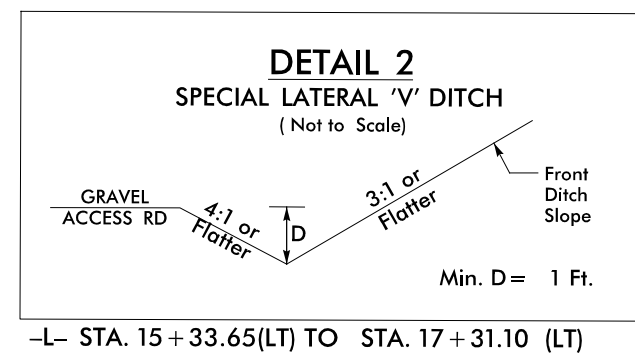
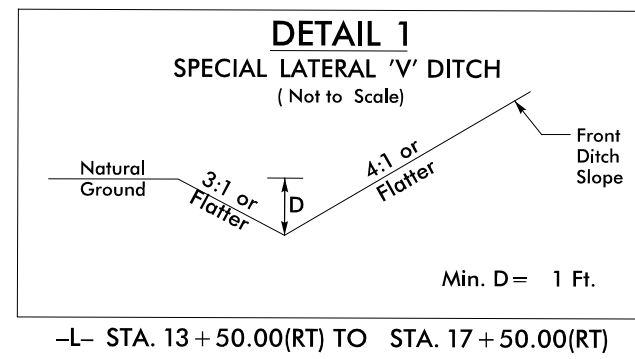

NOTE:  
SHOULDER SLOPES SHALL BE MATTED WITH TEMPORARY  
EROSION CONTROL MATTING ONCE BROUGHT TO GRADE.

NOTE:  
IMPERVIOUS DIKS MAY BE MODIFIED AND/OR  
ELIMINATED AS DIRECTED.

