

8/17/99

TIP PROJECT: BR-0073

CONTRACT:

STATE OF NORTH CAROLINA DEPARTMENT OF TRANSPORTATION

PAVEMENT MARKING PLANS COLUMBUS COUNTY

LOCATION: BRIDGE NO. 230005 ON US 76 OVER GAPWAY SWAMP

TIP NO. BR - 0073	SHEET NO. PMP - 1
APPROVED: _____ DATE: 2/13/2023	
SEAL 	
DOCUMENT NOT CONSIDERED FINAL UNLESS ALL SIGNATURES COMPLETED	

INDEX

SHEET NO.	DESCRIPTION
PMP-1	PAVEMENT MARKING TITLE SHEET
PMP-2	PAVEMENT MARKING SCHEDULE & DETAILS

PAVEMENT MARKING GENERAL NOTES

- THE FOLLOWING GENERAL NOTES APPLY AT ALL TIMES FOR THE DURATION OF THE CONSTRUCTION PROJECT, EXCEPT WHEN OTHERWISE NOTED IN THE PLAN, OR DIRECTED BY THE ENGINEER.
- A) INSTALL PAVEMENT MARKINGS AND PAVEMENT MARKERS ON THE FINAL SURFACE AS FOLLOWS:
- | ROAD NAME | MARKING | MARKER |
|--------------------|---------------|------------------|
| US 76 -L- | THERMOPLASTIC | PERMANENT RAISED |
| US 76 -L- (BRIDGE) | POLYUREA | PERMANENT RAISED |
- B) TIE PROPOSED PAVEMENT MARKING LINES TO EXISTING PAVEMENT MARKING LINES.
 - C) REMOVE/REPLACE ANY CONFLICTING/DAMAGED PAVEMENT MARKINGS AND MARKERS.
 - D) PASSING ZONE WILL BE DETERMINED IN THE FIELD AND MUST BE APPROVED BY THE ENGINEER.
 - E) REMOVE ALL RESIDUE AND SURFACE LAITANCE BY ACCEPTABLE METHODS ON CONCRETE BRIDGE DECKS PRIOR TO PLACING POLYUREA PAVEMENT MARKING MATERIAL.

ROADWAY STANDARD DRAWING

THE FOLLOWING ROADWAY STANDARDS AS APPEAR IN "ROADWAY STANDARD DRAWINGS" - N.C. DEPARTMENT OF TRANSPORTATION - RALEIGH, N.C., DATED JANUARY 2018 ARE APPLICABLE TO THIS PROJECT AND BY REFERENCE HEREBY ARE CONSIDERED A PART OF THESE PLANS:

STD. NO.	TITLE
1205.01	PAVEMENT MARKINGS - LINE TYPES AND OFFSETS
1205.02	PAVEMENT MARKINGS - TWO-LANE AND MULTILANE ROADWAYS
1205.12	PAVEMENT MARKINGS - BRIDGES
1250.01	RAISED PAVEMENT MARKERS - INSTALLATION SPACING
1251.01	RAISED PAVEMENT MARKERS - PERMANENT AND TEMPORARY
1261.01	GUARDRAIL AND BARRIER DELINEATORS - INSTALLATION SPACING
1261.02	GUARDRAIL AND BARRIER DELINEATORS - TYPES AND MOUNTING
1262.01	GUARDRAIL END DELINEATION

SUMMARY OF QUANTITIES

ITEM NO.		ITEM DESCRIPTION	QUANTITY	UNIT
DESC. NO.	SECT. NO.			
4192000000-N	907	DISPOSAL OF SUPPORT, U-CHANNEL	2	EA.
4238000000-N	907	DISPOSAL OF SIGN D, E, OR F	2	EA.
4685000000-E	1205	THERMOPLASTIC PAVEMENT MARKING LINES (4", 90 MILS)	3416	L.F.
4847010000-E	1205	POLYUREA PAVEMENT MARKING LINES (4", 20 MILS)	648	L.F.
4900000000-N	1251	PERMANENT RAISED PAVEMENT MARKERS	13	EA.

PLAN REVIEWED BY: N.C.D.O.T. SIGNING AND DELINEATION UNIT

<u>AYMAN ALQUDWAH, PE, CPM</u>	SIGNING & DELINEATION REGIONAL ENGINEER
<u>DERRICK BEARD</u>	SIGNING & DELINEATION PROJECT DESIGN ENGINEER



PLANS PREPARED BY:
VOLKERT, Inc.

<u>EMILY MURRAY, P.E.</u>	PROJECT ENGINEER
<u>ZACHARY THORNTON, P.E.</u>	PROJECT DESIGN ENGINEER

VOLKERT
5430 Wade Park Blvd., Suite 410
Raleigh, NC 27606
Tel. 919-854-0344 Fax. 919-854-0355
NC License No. F-0765

TIP NO. BR-0073	SHEET NO. PMP-02
APPROVED: _____	
DATE: 1/9/2023	
SEAL	
	

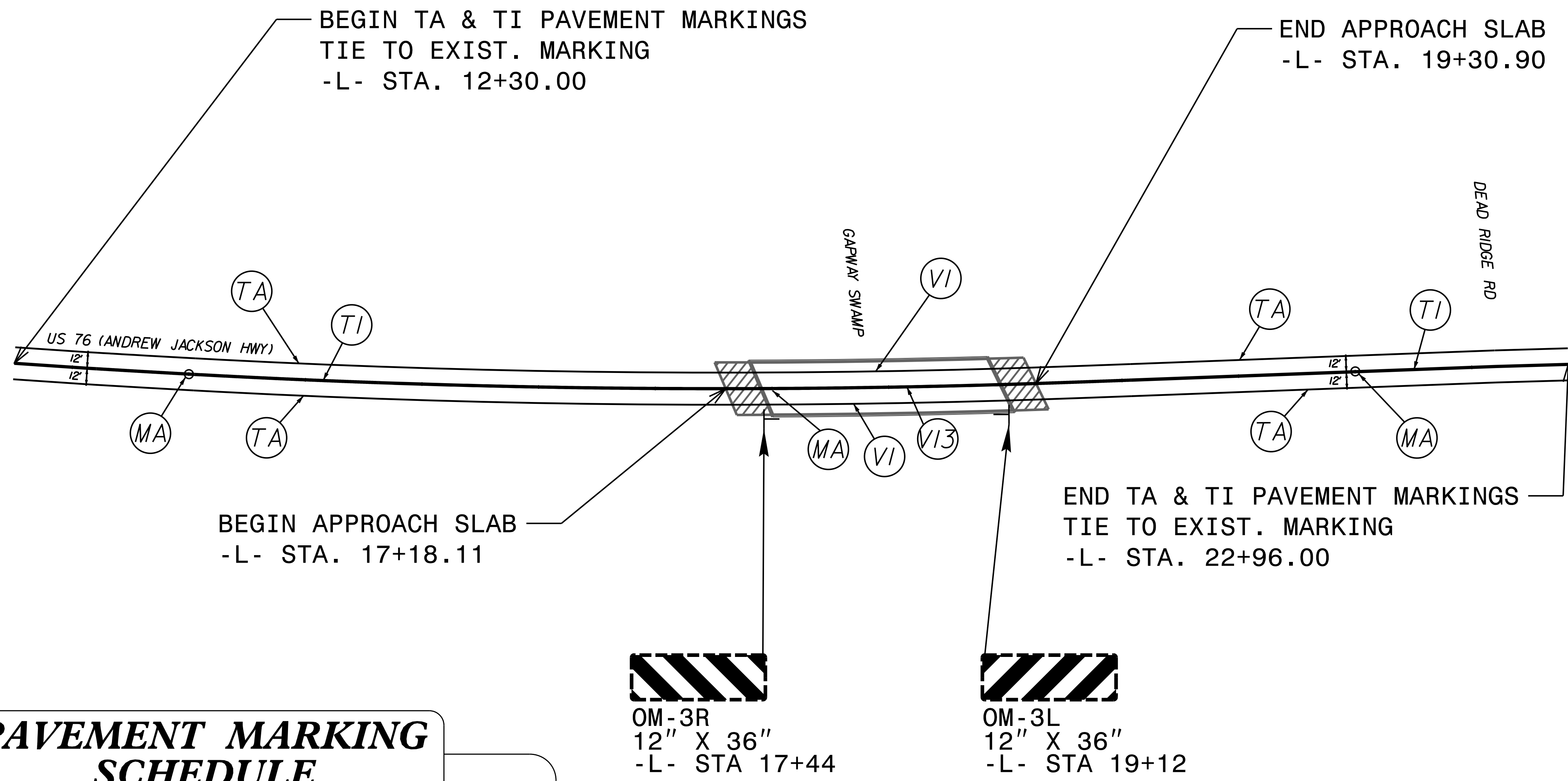
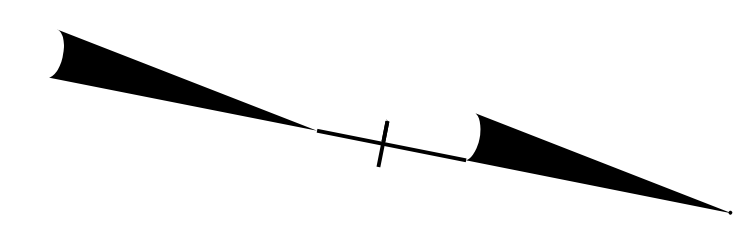

PAVEMENT MARKING SCHEDULE

SYMBOL	DESCRIPTION
TA	THERMO (4", 90 MIL) WHITE EDGELINE
TI	YELLOW DOUBLE CENTER
V1	POLYUREA (4", 20 MIL) WHITE EDGELINE
V13	YELLOW DOUBLE CENTER
MA	PERMANENT RAISED PAVEMENT MARKER YELLOW & YELLOW

DISPOSAL OF EXISTING SIGN SYSTEMS

VOLKERT
 5430 Wade Park Blvd., Suite 410
 Raleigh, NC 27606
 Tel. 919-854-0344 Fax: 919-854-0355
 NC License No. F-0765

FINAL PAVEMENT SCHEDULE & DETAIL