

TIP PROJECT: BR-0073

CONTRACT: C204795

See Sheet 1A For Index of Sheets

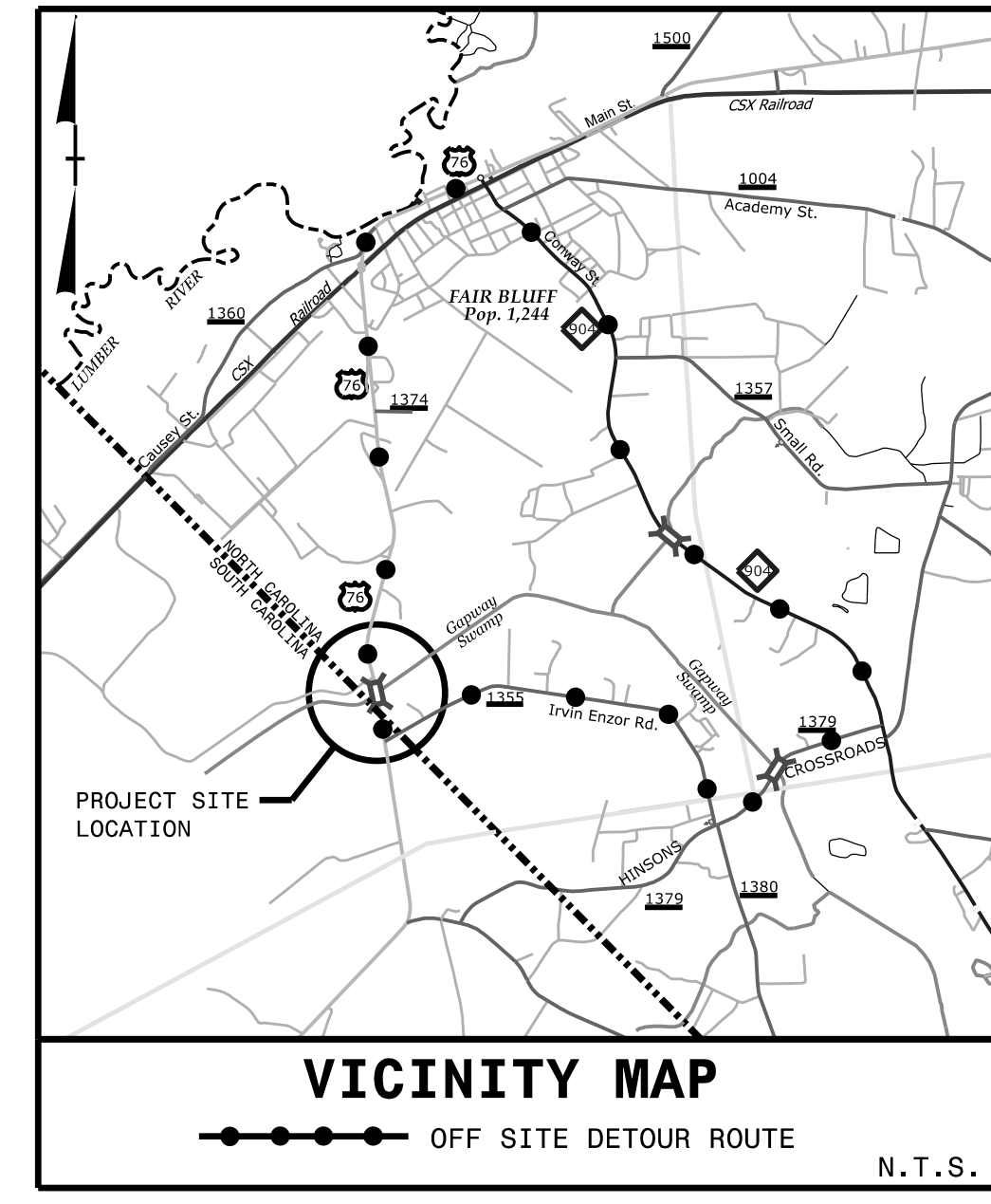

# STATE OF NORTH CAROLINA DIVISION OF HIGHWAYS

## COLUMBUS COUNTY

LOCATION: *BRIDGE NO. 230005 ON US 76 OVER GAPWAY SWAMP*  
TYPE OF WORK: *GRADING, DRAINAGE, PAVING, & STRUCTURE*

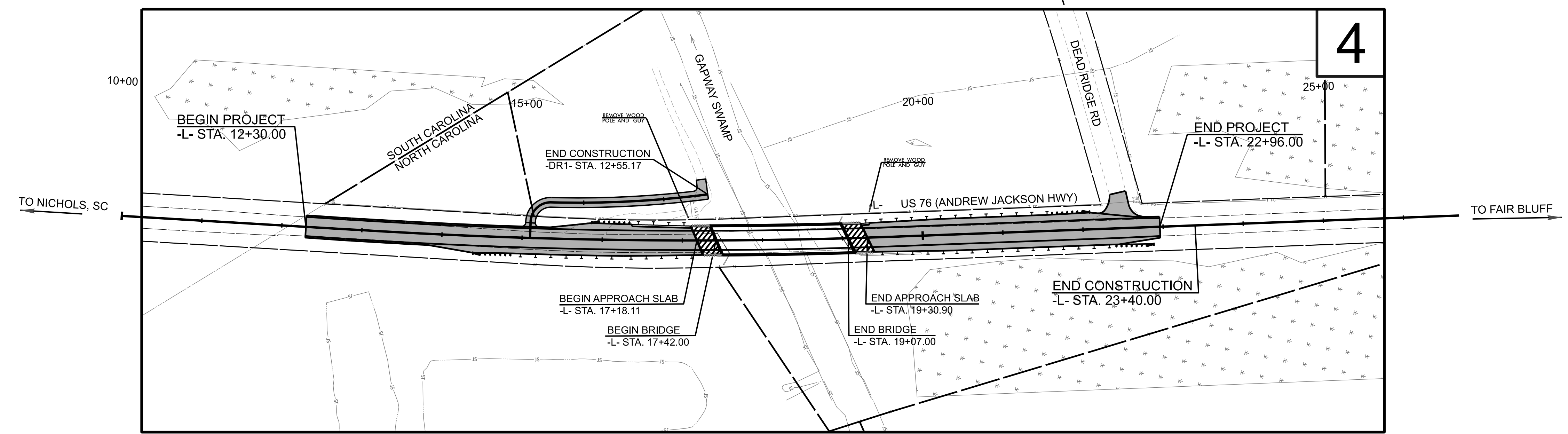
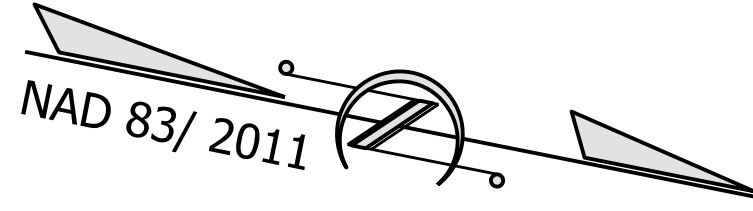
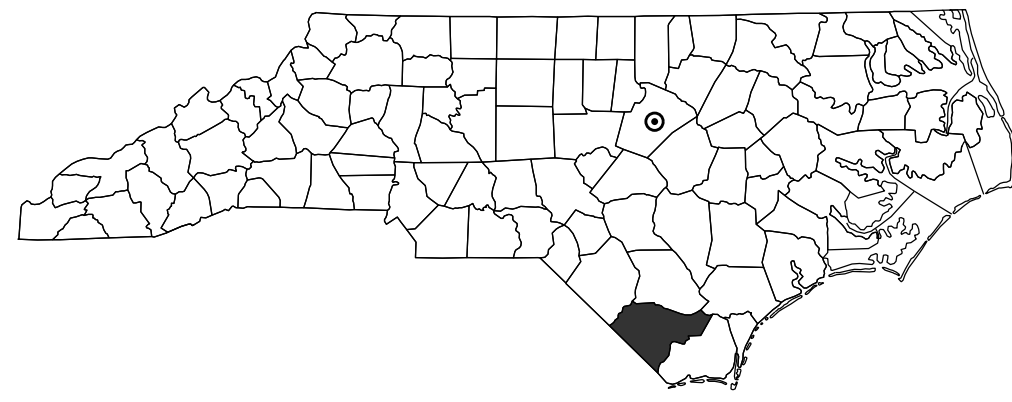

STATE	STATE PROJECT REFERENCE NO.	SHEET NO.	TOTAL SHEETS
N.C.	BR-0073	1	
STATE PROJ. NO.	F. A. PROJ. NO.	DESCRIPTION	
67073.1.1		PE	
67073.2.1		R/W & UTIL.	
67073.3.1		CONST.	

THERE IS NO CONTROL OF ACCESS ON THIS PROJECT.

DOCUMENT NOT CONSIDERED FINAL  
UNLESS ALL SIGNATURES COMPLETED

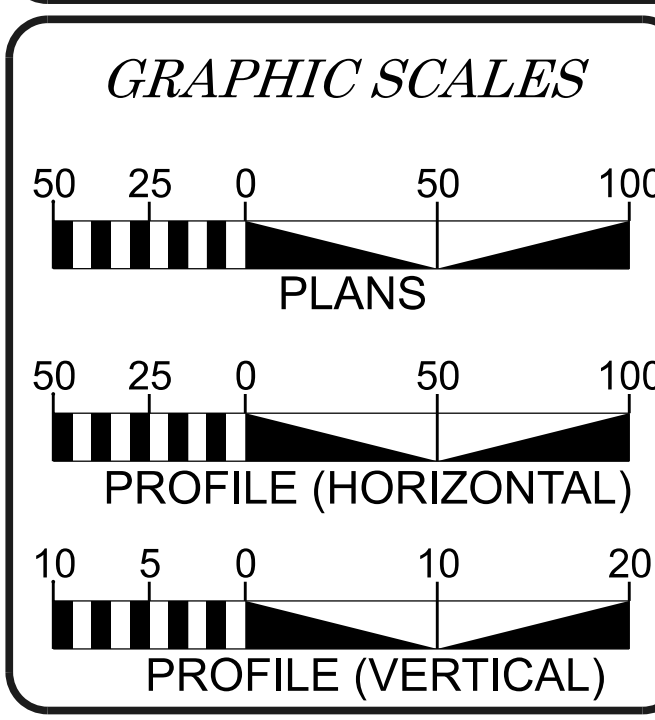

**DESIGN DATA**

ADT 2023 =	1,057
ADT 2045 =	1,400
K =	N/A
D =	N/A
T =	9% *
V =	60 MPH
* TTST =	5%    DUALS = 4%
FUNC CLASS =	PRINCIPAL ARTERIAL
STATEWIDE TIER	

**PROJECT LENGTH**

LENGTH ROADWAY TIP PROJECT BR-0073	=	0.171 MILES
LENGTH STRUCTURES TIP PROJECT BR-0073	=	0.031 MILES
TOTAL LENGTH TIP PROJECT BR-0073	=	0.202 MILES

PLANS PREPARED BY:  
**wsp**  
434 FAYETTEVILLE ST. #1500  
RALEIGH, N.C. 27601  
NC ENG. F. 1253  
2018 STANDARD SPECIFICATIONS

RIGHT OF WAY DATE:  
**MAY 31, 2022**

LETTING DATE:  
**APRIL 18, 2023**

PLANS PREPARED FOR:  
DIVISION OF HIGHWAYS  
STRUCTURES MGMT UNIT  
1000 BIRCH RIDGE DRIVE  
RALEIGH, NC 27610

**CHRISTOPHER H. LEE, PE**  
PROJECT ENGINEER

**DAVID STUTTS, PE**  
PROJECT ENGINEER - PEP/PROGRAM MGMT

**HYDRAULICS ENGINEER**

*(Signature)*

**ROADWAY DESIGN ENGINEER**

*(Signature)*

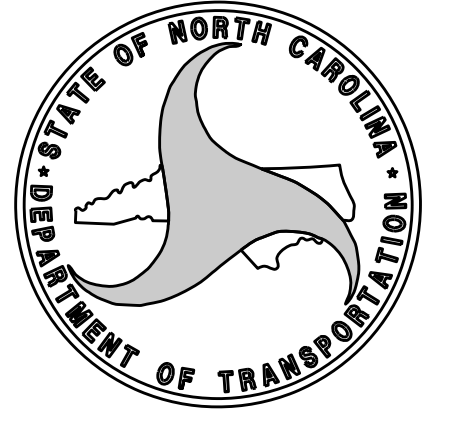



INDEX OF SHEETS

SHEET NUMBER	SHEET
1	TITLE SHEET
1A	INDEX OF SHEETS, GENERAL NOTES, AND STANDARD DRAWINGS
1B	CONVENTIONAL SYMBOLS
2A-1	PAVEMENT SCHEDULE, TYPICAL SECTIONS, AND DETAILS FOR WEDGING, MILLING, & SHOULDER BERM GUTTER
2C-1	SPECIAL DETAIL FOR GUARDRAIL INSTALLATION
2C-2	GREU TYPE TL-3 DETAILS
3B-1	ROADWAY SUMMARIES
3D-1	DRAINAGE SUMMARY
3G-1	GEOTECHNICAL SUMMARIES
4	PLAN AND PROFILE SHEET
RW01-1 THRU RW-04	SURVEY CONTROL, EXISTING CENTERLINES, RIGHT OF WAY, EASEMENTS, AND PROPERTY TIES
TMP-1 THRU TMP-4	TRAFFIC MANAGEMENT PLANS
PMP-1 AND PMP-2	PAVEMENT MARKING PLANS
EC-1 THRU EC-5	EROSION CONTROL PLANS
X1-A	CROSS-SECTION SUMMARY
X-1 THRU X-12	CROSS-SECTION PLANS
1 THRU 6	PAVEMENT RESURFACING PLANS
S-1 THRU S-39	STRUCTURES PLANS

GENERAL NOTES: 2018 SPECIFICATIONS

EFFECTIVE: 01-16-2018  
REVISED:

EFF. 01-16-2018  
REV.

GRADE LINE:  
GRADING AND SURFACING:

THE GRADE LINES SHOWN DENOTE THE FINISHED ELEVATION OF THE PROPOSED SURFACING AT GRADE POINTS SHOWN ON THE TYPICAL SECTIONS. GRADE LINES MAY BE ADJUSTED AT THEIR BEGINNING AND ENDING AND AT STRUCTURES AS DIRECTED BY THE ENGINEER IN ORDER TO SECURE A PROPER TIE-IN.

CLEARING:

CLEARING ON THIS PROJECT SHALL BE PERFORMED TO THE LIMITS ESTABLISHED BY METHOD II.

SUPERELEVATION:

ALL CURVES ON THIS PROJECT SHALL BE SUPERELEVATED IN ACCORDANCE WITH STD. NO. 225.04 USING THE RATE OF SUPERELEVATION AND RUNOFF SHOWN ON THE PLANS. SUPERELEVATION IS TO BE REVOLVED ABOUT THE GRADE POINTS SHOWN ON THE TYPICAL SECTIONS.

SHOULDER CONSTRUCTION:

ASPHALT, EARTH, AND CONCRETE SHOULDER CONSTRUCTION ON THE HIGH SIDE OF SUPERELEVATED CURVES SHALL BE IN ACCORDANCE WITH STD. NO. 560.01

SIDE ROADS:

THE CONTRACTOR WILL BE REQUIRED TO DO ALL NECESSARY WORK TO PROVIDE SUITABLE CONNECTIONS WITH ALL ROADS, STREETS, AND DRIVES ENTERING THIS PROJECT. THIS WORK WILL BE PAID FOR AT THE CONTRACT UNIT PRICE FOR THE PARTICULAR ITEMS INVOLVED.

SUBSURFACE DRAINS:

SUBSURFACE DRAINS SHALL BE CONSTRUCTED IN ACCORDANCE WITH STD. NO. 815.02 AT LOCATIONS DIRECTED BY THE ENGINEER.

DRIVEWAYS:

DRIVEWAYS SHALL BE CONSTRUCTED IN ACCORDANCE WITH STD. 848.03 AT LOCATIONS SHOWN ON PLANS OR AS DIRECTED BY THE ENGINEER.

GUARDRAIL:

THE GUARDRAIL LOCATIONS SHOWN ON THE PLANS MAY BE ADJUSTED DURING CONSTRUCTION AS DIRECTED BY THE ENGINEER. THE CONTRACTOR SHOULD CONSULT WITH THE ENGINEER PRIOR TO ORDERING GUARDRAIL MATERIAL.

SUBSURFACE PLANS:

NO SUBSURFACE PLANS ARE AVAILABLE ON THIS PROJECT. THE CONTRACTOR SHOULD MAKE HIS OWN INVESTIGATION AS TO THE SUBSURFACE CONDITIONS.

END BENTS:

THE ENGINEER SHALL CHECK THE STRUCTURE END BENT PLANS, DETAILS, AND CROSS-SECTION PRIOR TO SETTING OF THE SLOPE STAKES FOR THE EMBANKMENT OR EXCAVATION APPROACHING A BRIDGE.

UTILITIES:

UTILITY OWNERS ON THIS PROJECT ARE Riverstreet Networks  
ANY RELOCATION OF EXISTING UTILITIES WILL BE ACCOMPLISHED BY OTHERS.

RIGHT-OF-WAY MARKERS:

ALL RIGHT-OF-WAY MARKERS ON THIS PROJECT SHALL BE PLACED BY OTHERS.

2018 ROADWAY ENGLISH STANDARD DRAWINGS

THE FOLLOWING ROADWAY STANDARDS AS APPEAR IN "ROADWAY STANDARD DRAWINGS" HIGHWAY DESIGN BRANCH - N. C. DEPARTMENT OF TRANSPORTATION - RALEIGH, N. C., DATED JANUARY, 2018 ARE APPLICABLE TO THIS PROJECT AND BY REFERENCE HEREBY ARE CONSIDERED A PART OF THESE PLANS:

STD.NO.	TITLE
DIVISION 2 - EARTHWORK	
200.02	METHOD OF CLEARING - METHOD II
225.02	GUIDE FOR GRADING SUBGRADE - SECONDARY AND LOCAL
225.04	METHOD OF OBTAINING SUPERELEVATION - TWO LANE PAVEMENT
DIVISION 3 - PIPE CULVERTS	
300.01	METHOD OF PIPE INSTALLATION
DIVISION 4 - MAJOR STRUCTURES	
422.01	BRIDGE APPROACH FILLS - TYPE I STANDARD APPROACH FILL
DIVISION 5 - SUBGRADE, BASES AND SHOULDERS	
560.01	METHOD OF SHOULDER CONSTRUCTION - HIGH SIDE OF SUPERELEVATED CURVE - METHOD I
DIVISION 6 - ASPHALT BASES AND PAVEMENTS	
654.01	PAVEMENT REPAIRS
DIVISION 8 - INCIDENTALS	
815.02	SUBSURFACE DRAIN
840.00	CONCRETE BASE PAD FOR DRAINAGE STRUCTURES
840.25	ANCHORAGE FOR FRAMES
840.29	FRAMES AND NARROW SLOT FLAT GRATES
840.35	TRAFFIC BEARING GRATED DROP INLET - FOR CAST IRON DOUBLE FRAME AND GRATES
840.46	TRAFFIC BEARING PRECAST DRAINAGE STRUCTURE
840.66	DRAINAGE STRUCTURE STEPS
862.01	GUARDRAIL PLACEMENT
862.02	GUARDRAIL INSTALLATION
862.03	STRUCTURE ANCHOR UNITS
876.02	GUIDE FOR RIP RAP AT PIPE OUTLETS
876.04	DRAINAGE DITCHES WITH CLASS 'B' RIP RAP

BR-0073

4RDI IA

ROADWAY DESIGN ENGINEER

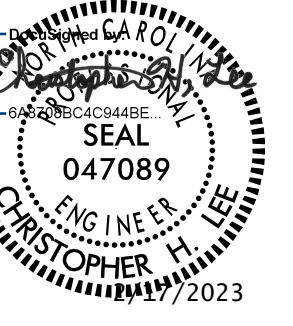

DOCUMENT NOT CONSIDERED FINAL UNLESS ALL SIGNATURES COMPLETED

STATE OF NORTH CAROLINA

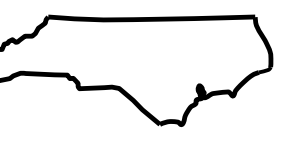

ROADWAY DESIGN UNIT

PREPARED BY





















434 FAYETTEVILLE ST. #1500  
RALEIGH, NC 27601  
NC ENG P-1253











# STATE OF NORTH CAROLINA, DIVISION OF HIGHWAYS CONVENTIONAL PLAN SHEET SYMBOLS

Note: Not to Scale











### BOUNDARIES AND PROPERTY:

State Line	-----
County Line	-----
Township Line	-----
City Line	-----
Reservation Line	-----
Property Line	-----
Existing Iron Pin (EIP)	----- 
Computed Property Corner	----- 
Existing Concrete Monument (ECM)	----- 
Parcel / Sequence Number	----- 
Existing Fence Line	----- 
Proposed Woven Wire Fence	----- 
Proposed Chain Link Fence	----- 
Proposed Barbed Wire Fence	----- 
Existing Wetland Boundary	----- 
Proposed Wetland Boundary	----- 
Existing Endangered Animal Boundary	----- 
Existing Endangered Plant Boundary	----- 
Existing Historic Property Boundary	----- 
Known Contamination Area: Soil	----- 
Potential Contamination Area: Soil	----- 
Known Contamination Area: Water	----- 
Potential Contamination Area: Water	----- 
Contaminated Site: Known or Potential	----- 



### BUILDINGS AND OTHER CULTURE:

Gas Pump Vent or U/G Tank Cap	----- 
Sign	----- 
Well	----- 
Small Mine	----- 
Foundation	----- 
Area Outline	----- 
Cemetery	----- 
Building	----- 
School	----- 
Church	----- 
Dam	----- 





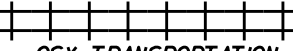





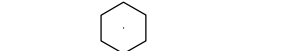



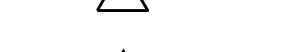







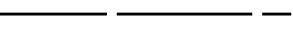

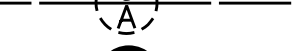
### HYDROLOGY:

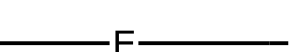
Stream or Body of Water	-----
Hydro, Pool or Reservoir	----- 
Jurisdictional Stream	----- 
Buffer Zone 1	----- 
Buffer Zone 2	----- 
Flow Arrow	----- 
Disappearing Stream	----- 
Spring	----- 
Wetland	----- 
Proposed Lateral, Tail, Head Ditch	----- 
False Sump	----- 









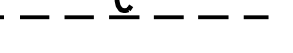

### RAILROADS:



Standard Gauge	----- 
RR Signal Milepost	----- 
Switch	----- 
RR Abandoned	-----
RR Dismantled	-----

### RIGHT OF WAY & PROJECT CONTROL:

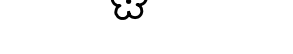

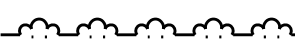

Primary Horiz Control Point	----- 
Primary Horiz and Vert Control Point	----- 
Secondary Horiz and Vert Control Point	----- 
Vertical Benchmark	----- 
Existing Right of Way Monument	----- 
Proposed Right of Way Monument (Rebar and Cap)	----- 
Proposed Right of Way Monument (Concrete)	----- 
Existing Permanent Easement Monument	----- 
Proposed Permanent Easement Monument (Rebar and Cap)	----- 
Existing C/A Monument	----- 
Proposed C/A Monument (Rebar and Cap)	----- 
Proposed C/A Monument (Concrete)	----- 
Existing Right of Way Line	----- 
Proposed Right of Way Line	----- 
Existing Control of Access Line	----- 
Proposed Control of Access Line	----- 
Proposed ROW and CA Line	----- 
Existing Easement Line	----- 
Proposed Temporary Construction Easement	----- 
Proposed Temporary Drainage Easement	----- 
Proposed Permanent Drainage Easement	----- 
Proposed Permanent Drainage/Utility Easement	----- 
Proposed Permanent Utility Easement	----- 
Proposed Temporary Utility Easement	----- 
Proposed Aerial Utility Easement	----- 

### ROADS AND RELATED FEATURES:

Existing Edge of Pavement	-----
Existing Curb	-----
Proposed Slope Stakes Cut	----- 
Proposed Slope Stakes Fill	----- 
Proposed Curb Ramp	----- 
Existing Metal Guardrail	----- 
Proposed Guardrail	----- 
Existing Cable Guiderail	----- 
Proposed Cable Guiderail	----- 
Equality Symbol	----- 
Pavement Removal	----- 
VEGETATION:	
Single Tree	----- 
Single Shrub	----- 
Hedge	----- 



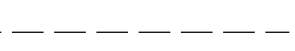
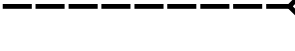
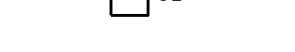

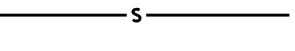





Woods Line	----- 
Orchard	----- 
Vineyard	----- 

### EXISTING STRUCTURES:



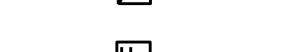

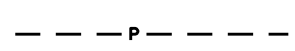
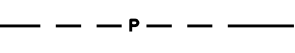
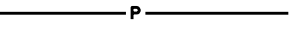





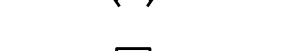

MAJOR:	
Bridge, Tunnel or Box Culvert	----- 
Bridge Wing Wall, Head Wall and End Wall	----- 
MINOR:	
Head and End Wall	----- 
Pipe Culvert	----- 
Footbridge	----- 
Drainage Box: Catch Basin, DI or JB	----- 
Paved Ditch Gutter	-----
Storm Sewer Manhole	----- 
Storm Sewer	----- 

### UTILITIES:

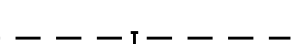
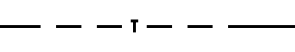
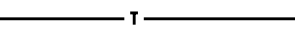
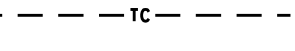
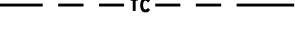







\* SUE - Subsurface Utility Engineering  
LOS - Level of Service - A,B,C or D (Accuracy)

POWER:	
Existing Power Pole	----- 
Proposed Power Pole	----- 
Existing Joint Use Pole	----- 
Proposed Joint Use Pole	----- 
Power Manhole	----- 
Power Line Tower	----- 
Power Transformer	----- 
U/G Power Cable Hand Hole	----- 
H-Frame Pole	----- 
U/G Power Line Test Hole (SUE - LOS A)*	----- 
U/G Power Line (SUE - LOS B)*	----- 
U/G Power Line (SUE - LOS C)*	----- 
U/G Power Line (SUE - LOS D)*	----- 

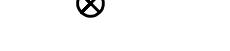



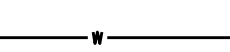
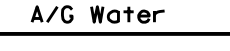

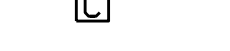

### TELEPHONE:

Existing Telephone Pole	----- 
Proposed Telephone Pole	----- 
Telephone Manhole	----- 
Telephone Pedestal	----- 
Telephone Cell Tower	----- 
U/G Telephone Cable Hand Hole	----- 
U/G Telephone Test Hole (SUE - LOS A)*	----- 
U/G Telephone Cable (SUE - LOS B)*	----- 
U/G Telephone Cable (SUE - LOS C)*	----- 
U/G Telephone Cable (SUE - LOS D)*	----- 
U/G Telephone Conduit (SUE - LOS B)*	----- 
U/G Telephone Conduit (SUE - LOS C)*	----- 
U/G Telephone Conduit (SUE - LOS D)*	----- 
U/G Fiber Optics Cable (SUE - LOS B)*	----- 
U/G Fiber Optics Cable (SUE - LOS C)*	----- 
U/G Fiber Optics Cable (SUE - LOS D)*	----- 

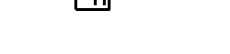



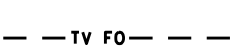
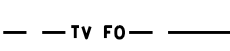
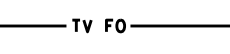

### WATER:

Water Manhole	----- 
Water Meter	----- 
Water Valve	----- 
Water Hydrant	----- 
U/G Water Line Test Hole (SUE - LOS A)*	----- 
U/G Water Line (SUE - LOS B)*	----- 
U/G Water Line (SUE - LOS C)*	----- 
U/G Water Line (SUE - LOS D)*	----- 
Above Ground Water Line	----- 





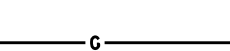
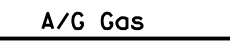



### TV:

TV Pedestal	----- 
TV Tower	----- 
U/G TV Cable Hand Hole	----- 
U/G TV Test Hole (SUE - LOS A)*	----- 
U/G TV Cable (SUE - LOS B)*	----- 
U/G TV Cable (SUE - LOS C)*	----- 
U/G TV Cable (SUE - LOS D)*	----- 
U/G Fiber Optic Cable (SUE - LOS B)*	----- 
U/G Fiber Optic Cable (SUE - LOS C)*	----- 
U/G Fiber Optic Cable (SUE - LOS D)*	----- 

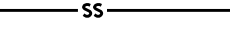



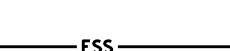





### GAS:

Gas Valve	----- 
Gas Meter	----- 
U/G Gas Line Test Hole (SUE - LOS A)*	----- 
U/G Gas Line (SUE - LOS B)*	----- 
U/G Gas Line (SUE - LOS C)*	----- 
U/G Gas Line (SUE - LOS D)*	----- 
Above Ground Gas Line	----- 

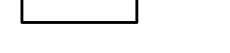
### SANITARY SEWER:

Sanitary Sewer Manhole	----- 
Sanitary Sewer Cleanout	----- 
U/G Sanitary Sewer Line	----- 
Above Ground Sanitary Sewer	----- 
SS Force Main Line Test Hole (SUE - LOS A)*	----- 
SS Force Main Line (SUE - LOS B)*	----- 
SS Force Main Line (SUE - LOS C)*	----- 
SS Force Main Line (SUE - LOS D)*	----- 

### MISCELLANEOUS:

Utility Pole	----- 
Utility Pole with Base	----- 
Utility Located Object	----- 
Utility Traffic Signal Box	----- 
Utility Unknown U/G Line (SUE - LOS B)*	----- 
U/G Tank; Water, Gas, Oil	----- 
Underground Storage Tank, Approx. Loc.	----- 
A/G Tank; Water, Gas, Oil	----- 
Geoenvironmental Boring	----- 
Abandoned According to Utility Records	----- 
End of Information	----- 



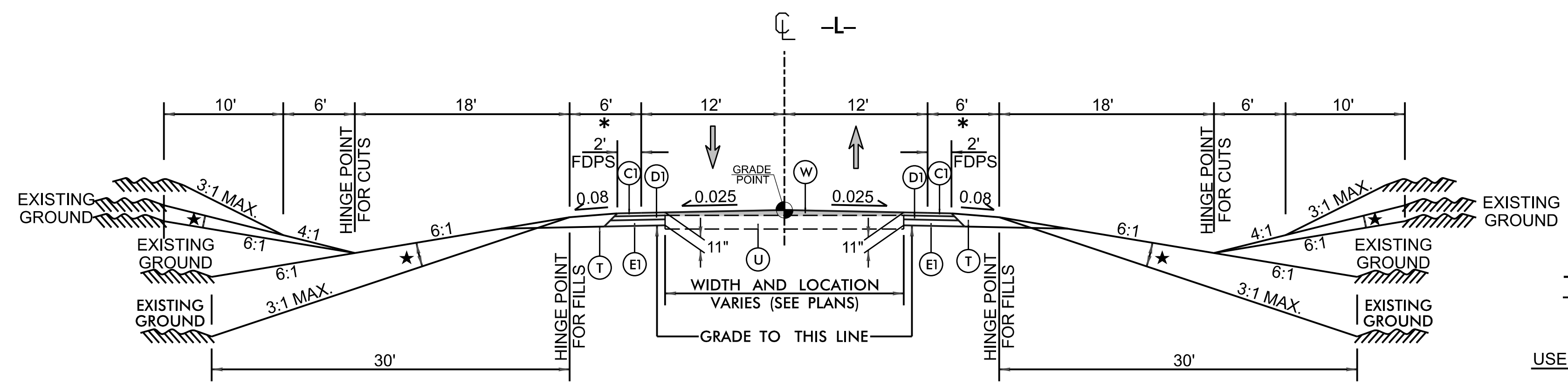

**TYPICAL SECTION NO. 1**

- \* 11' WITH GUARDRAIL
- \* VARIABLE SLOPE

USE TYPICAL SECTION NO. 1 AS FOLLOWS:

- L- STA. 12+30.00 TO 15+00.00
- L- STA. 21+00.00 TO 23+17.66

NOTE: SHOULDER WORK ONLY FOR  
-L- STA. 22+96.00 TO 23+17.66

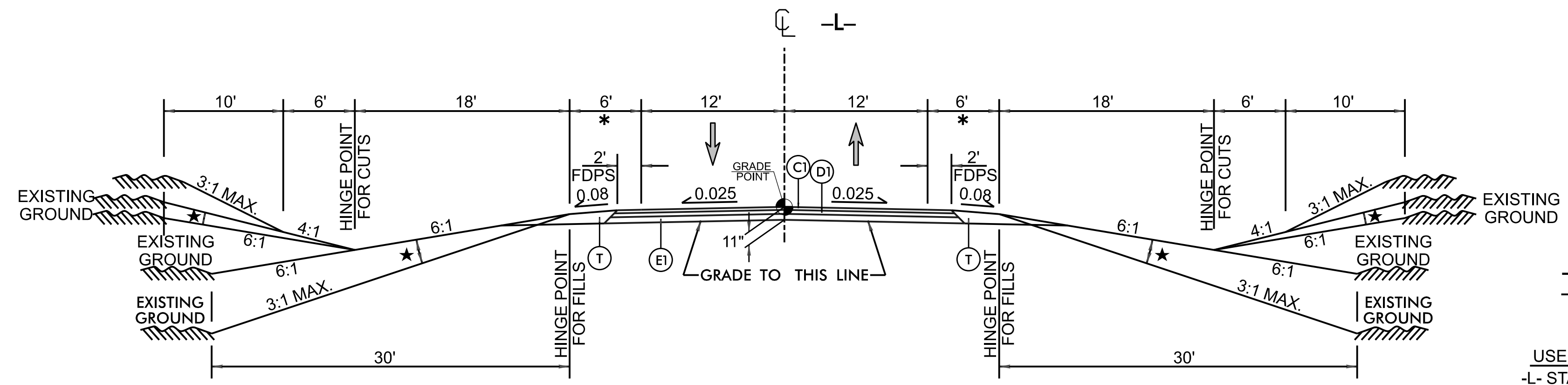

**TYPICAL SECTION NO. 2**

- \* 11' WITH GUARDRAIL
- \* VARIABLE SLOPE

USE TYPICAL SECTION NO. 2 AS FOLLOWS:

- L- STA. 15+00.00 TO 17+42.00 (BEGIN BRIDGE)
- L- STA. 19+07.00 (END BRIDGE) TO 21+00.00

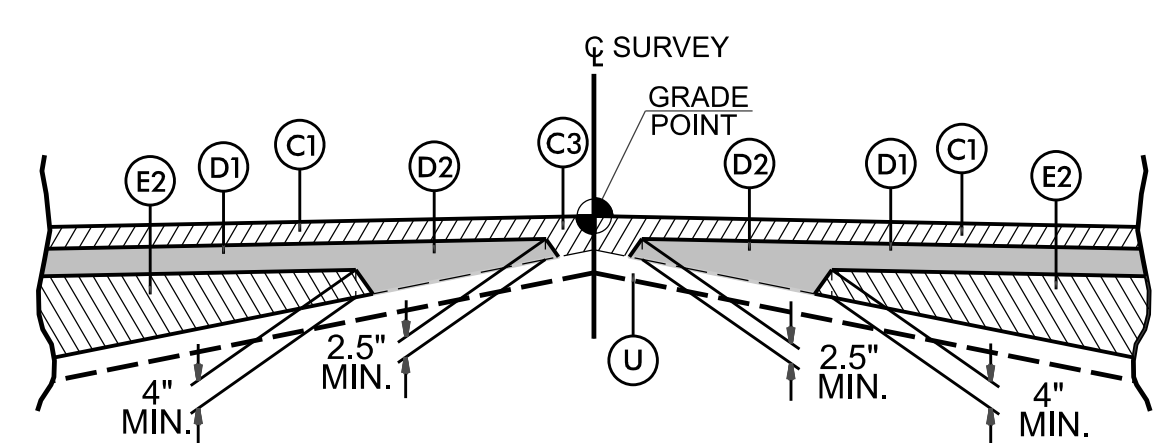

DETAIL SHOWING METHOD OF WEDGING NO. 1

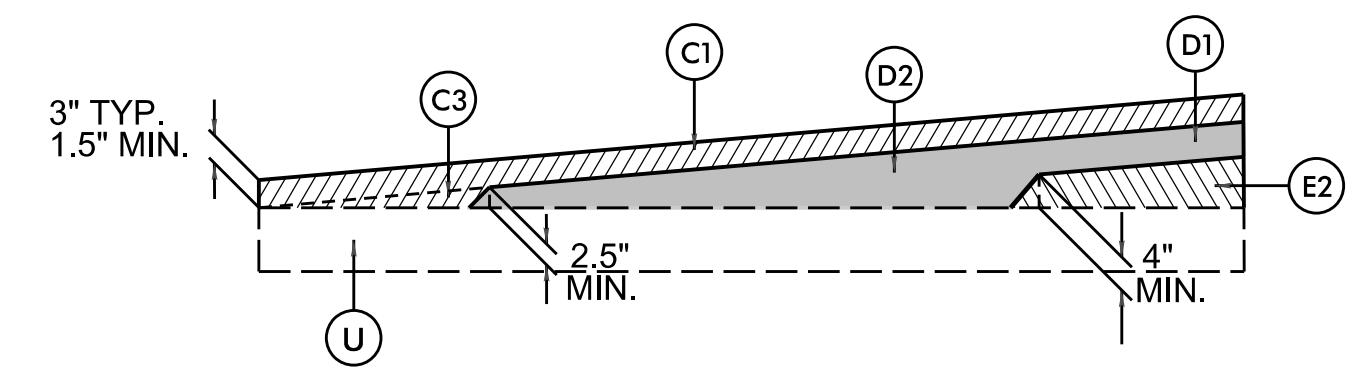

WEDGING DETAIL FOR RESURFACING

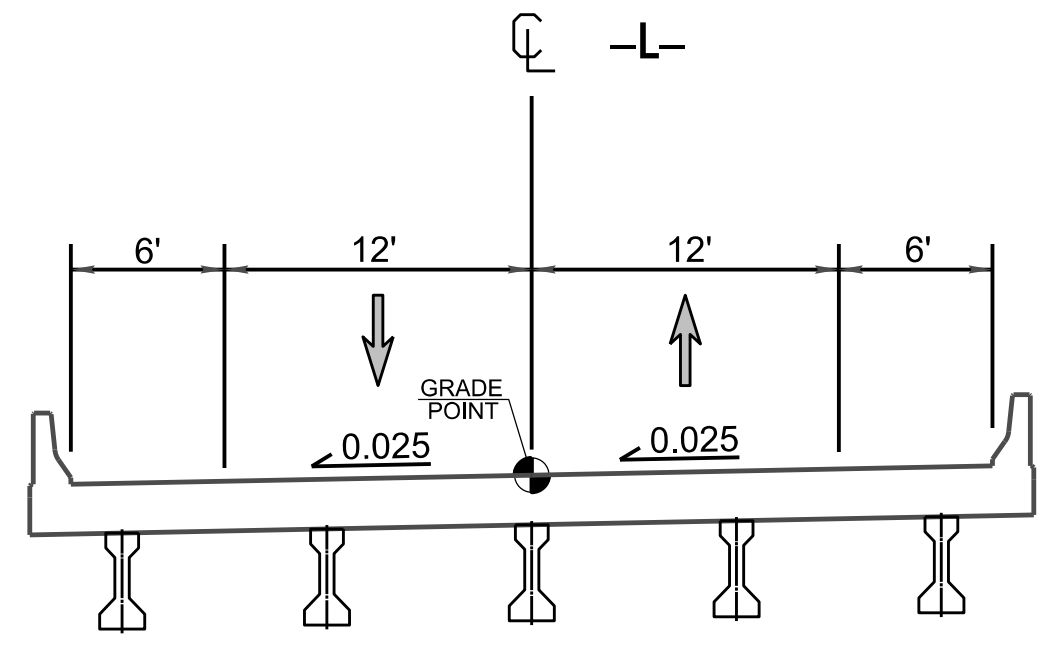

**BRIDGE SKETCH NO. 1**

USE BRIDGE TYPICAL SECTION AS FOLLOWS:

- L- STA. 17+42.00 (BEGIN BRIDGE) TO
- L- STA. 19+07.00 (END BRIDGE)

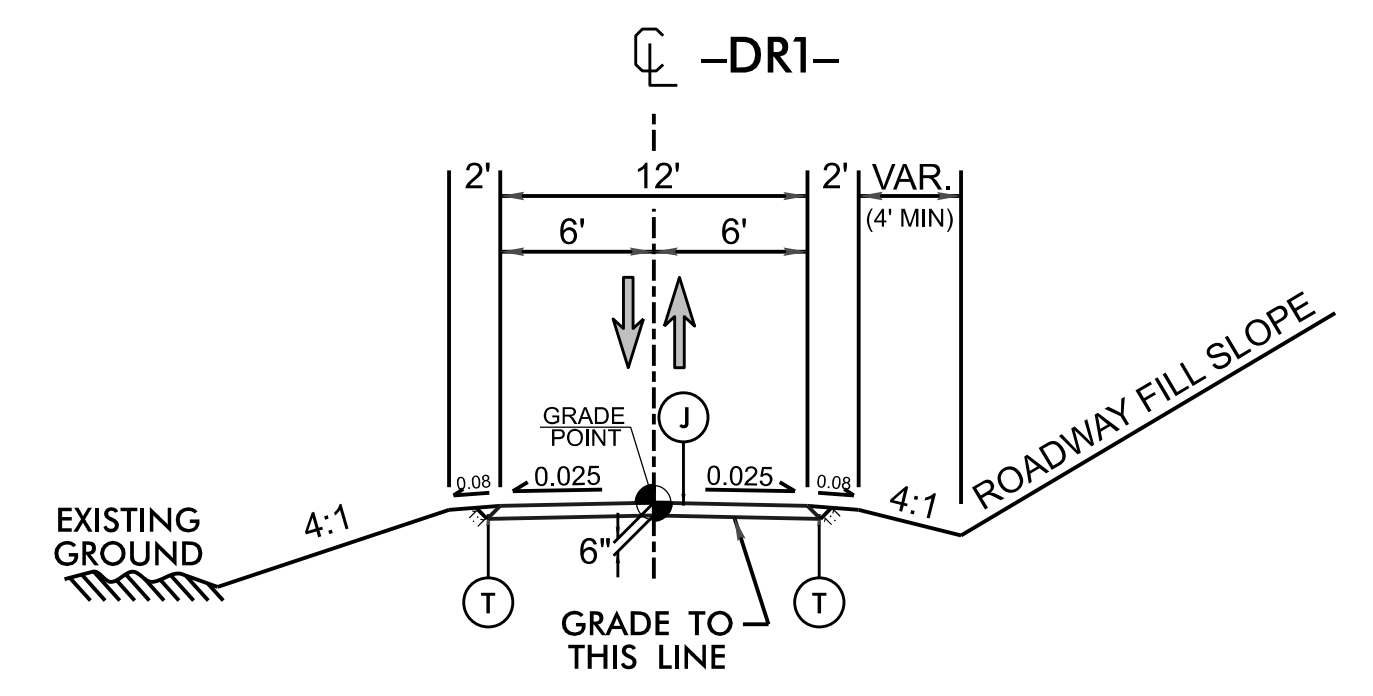

**TYPICAL SECTION NO. 3**

USE TYPICAL SECTION NO. 3 AS FOLLOWS:

- DR1- STA. 10+14.00 TO 12+55.17

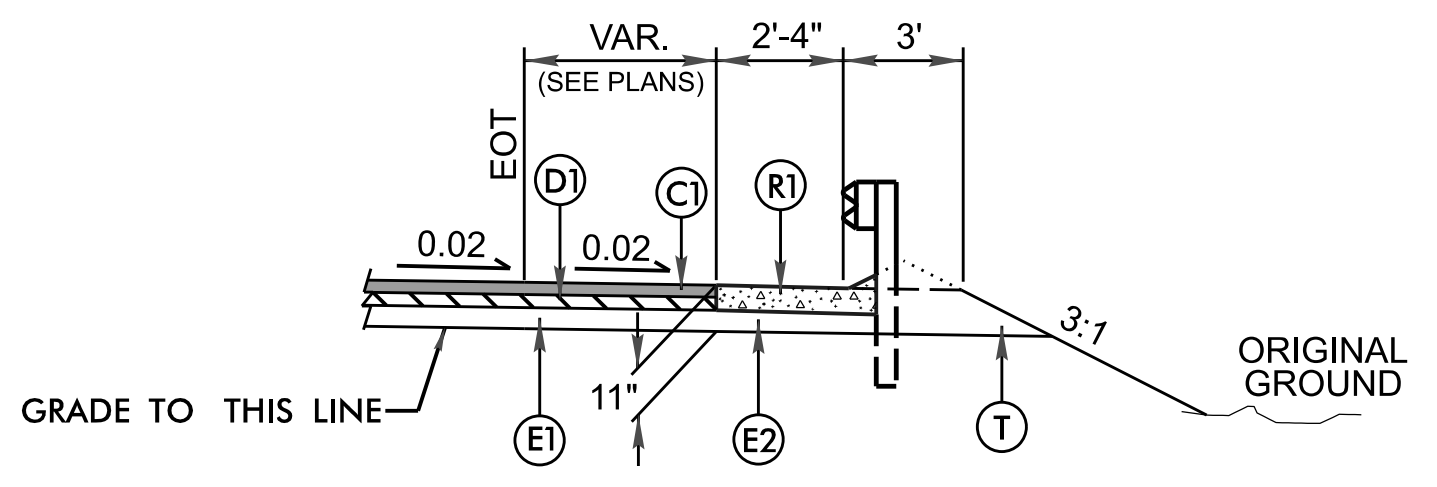

**TYPICAL SECTION FOR SHOULDER BERM GUTTER**

- L- STA 16+36.66 TO -L- STA 17+11.47 LT
- L- STA 19+23.87 TO -L- STA 19+33.86 LT

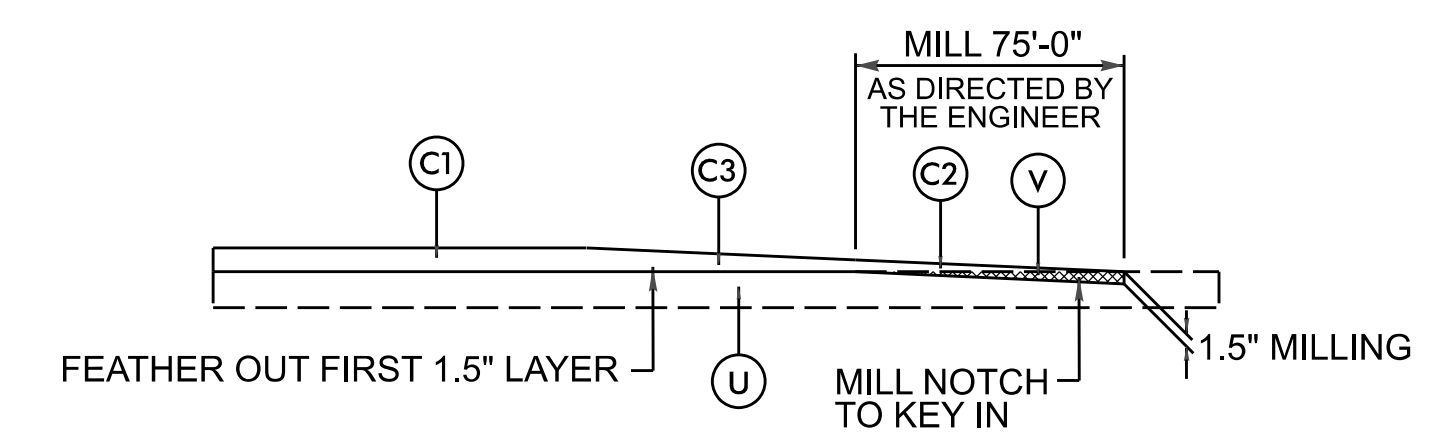

**INCIDENTAL MILLING OF EXISTING PAVEMENT AS DIRECTED BY ENGINEER**

- L- STA 12+30.00 TO -L- STA 13+05.00
- L- STA 22+21.00 TO -L- STA 22+96.00

PAVEMENT SCHEDULE (FINAL)	
C1	PROP. APPROX. 3" ASPHALT CONCRETE SURFACE COURSE, TYPE S9.5B, AT AN AVERAGE RATE OF 165 LBS. PER SQ. YD. IN EACH OF TWO LAYERS.
C2	PROP. APPROX. 1.5" ASPHALT CONCRETE SURFACE COURSE, TYPE S9.5B, AT AN AVERAGE RATE OF 165 LBS. PER SQ. YD.
C3	PROP. VAR. DEPTH ASPHALT CONCRETE SURFACE COURSE, TYPE S9.5B, AT AN AVERAGE RATE OF 110 LBS. PER SQ. YD. PER 1" DEPTH TO BE PLACED IN LAYERS NOT TO EXCEED 1.5" IN DEPTH.
D1	PROP. APPROX. 4" ASPHALT CONCRETE INTERMEDIATE COURSE, TYPE I19.0C, AT AN AVERAGE RATE OF 456 LBS. PER SQ. YD.
D2	PROP. VAR. DEPTH ASPHALT CONCRETE INTERMEDIATE COURSE, TYPE I19.0C, AT AN AVERAGE RATE OF 114 LBS. PER SQ. YD. PER 1" DEPTH TO BE PLACED IN LAYERS NOT LESS THAN 2.5" OR GREATER THAN 4" IN DEPTH.
E1	PROP. APPROX. 4" ASPHALT CONCRETE BASE COURSE, TYPE B25.0C, AT AN AVERAGE RATE OF 456 LBS. PER SQ. YD.
E2	PROP. VAR. DEPTH ASPHALT CONCRETE BASE COURSE, TYPE B25.0C, AT AN AVERAGE RATE OF 114 LBS. PER SQ. YD. PER 1" DEPTH TO BE PLACED IN LAYERS NOT LESS THAN 4" OR GREATER THAN 5.5" IN DEPTH.
J	PROP. 6" INCIDENTAL STONE BASE
R1	PROP. CONCRETE SHOULDER BERM GUTTER
T	EARTH MATERIAL.
U	EXISTING PAVEMENT.
V	INCIDENTAL MILLING BITUMINOUS PAVEMENT (0" TO 1.5" DEPTH). SEE MILLING DETAIL.
W	VARIABLE DEPTH ASPHALT PAVEMENT (SEE STANDARD WEDGING DETAILS).

NOTE: PAVEMENT EDGE SLOPES ARE 1:1 UNLESS SHOWN OTHERWISE.

**BR-0073**  
4RD1 2A-1  
ROADWAY DESIGN ENGINEER  
3/13/2023  
SEAL 04789  
PROFESSOR  
CHRISTOPHER H. LEE  
CHATELAIN, S.E.  
PAVEMENT DESIGN ENGINEER  
3/13/2023  
SEAL 022896  
PROFESSOR  
CLARK S. MORRISON  
MORRISON, S.E.  
DOCUMENT NOT CONSIDERED FINAL UNLESS ALL SIGNATURES COMPLETED  
STATE OF NORTH CAROLINA  
ROADWAY DESIGN UNIT  
PREPARED BY  
**WSP**  
434 FAYETTEVILLE ST., #1500  
RALEIGH, N.C. 27601  
NC ENG P-1253

STATE OF NORTH CAROLINA  
DEPT. OF TRANSPORTATION  
DIVISION OF HIGHWAYS  
RALEIGH, N.C.

ROADWAY DETAIL DRAWING FOR  
**GUARDRAIL INSTALLATION**

SHEET 6 OF 8  
**862D02**

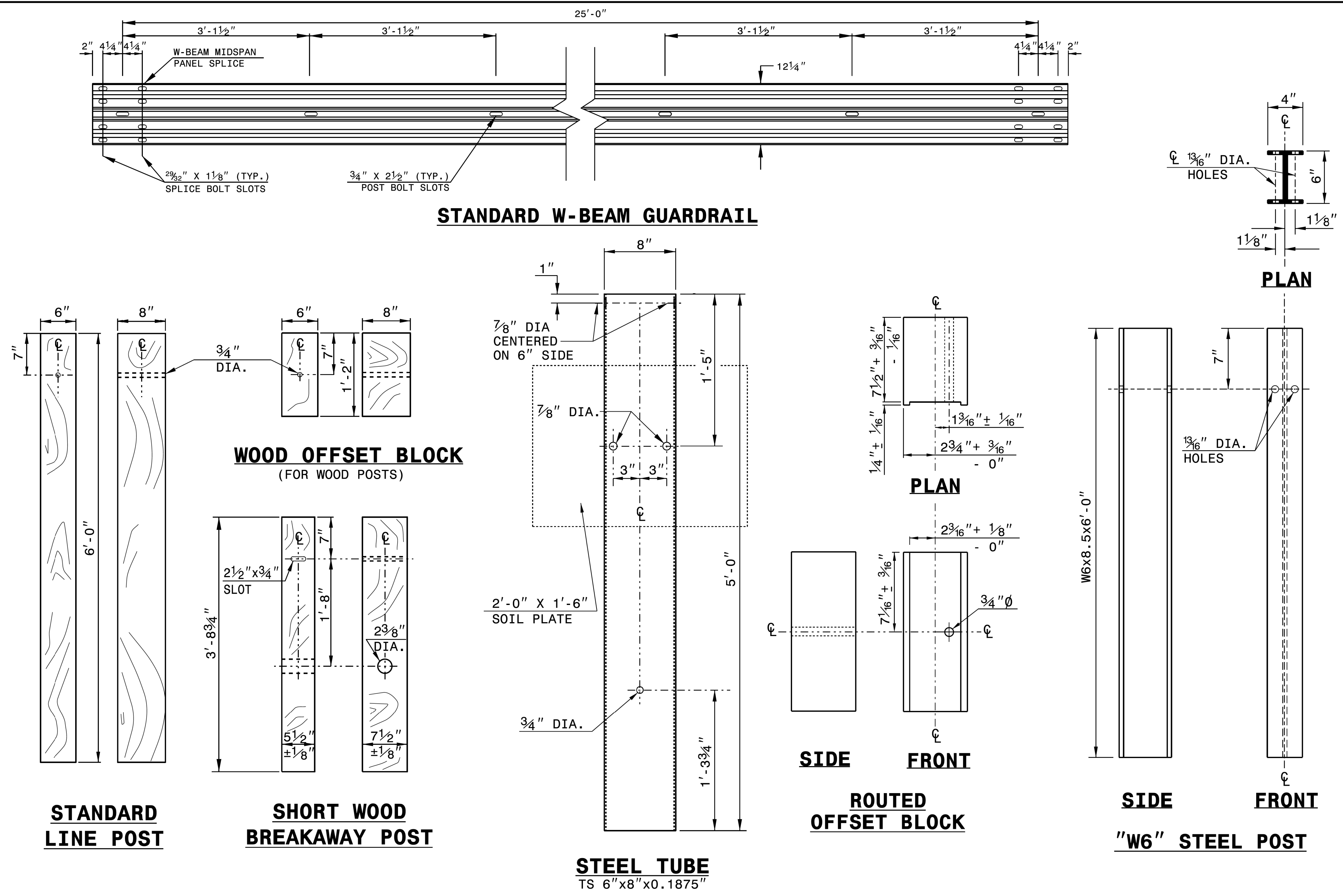

**SYSTEM PARTS**

PROJECT REFERENCE NO. SHEET NO.  
**DOCUMENT NOT CONSIDERED FINAL  
UNLESS ALL SIGNATURES COMPLETED**

STATE OF NORTH CAROLINA  
DEPT. OF TRANSPORTATION  
DIVISION OF HIGHWAYS  
RALEIGH, N.C.

ROADWAY DETAIL DRAWING FOR  
**GUARDRAIL INSTALLATION**

SHEET 6 OF 8  
**862D02**

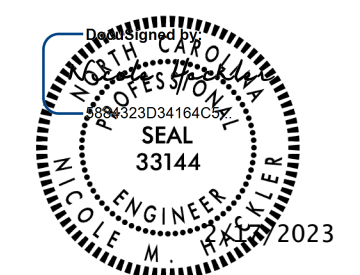
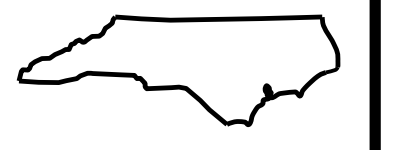

**CONTRACTS STANDARDS  
AND DEVELOPMENT UNIT**  
Office 919-707-6950 FAX 919-250-4119

**SEE TITLE BLOCK**

ORIGINAL BY: J. HOWERTON DATE: 3-7-2018  
MODIFIED BY: DATE: \_\_\_\_\_  
CHECKED BY: DATE: \_\_\_\_\_  
FILE SPEC.: \_\_\_\_\_



STATE OF NORTH CAROLINA DEPT. OF TRANSPORTATION DIVISION OF HIGHWAYS RALEIGH, N.C.

ROADWAY DETAIL DRAWING FOR STRUCTURE ANCHOR UNITS GUARDRAIL ANCHOR UNIT, TYPE III FOR ATTACHMENT TO RAIL ON BRIDGE

SHEET 1 OF 7 862D03

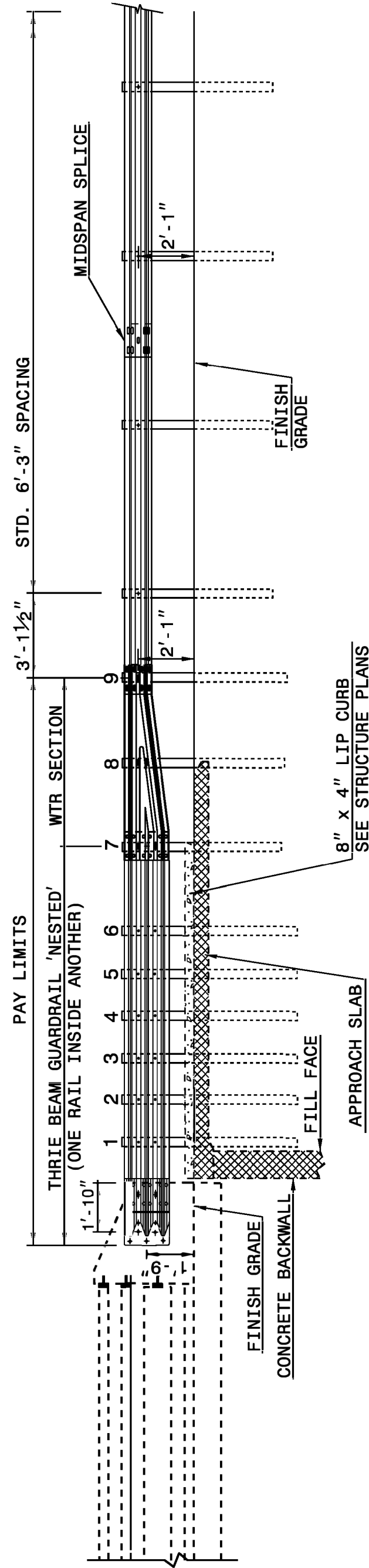

ELEVATION

NOTE: \*\*POST NOT REQUIRED FOR SKEW ANGLES GREATER THAN 150° OR LESS THAN 30° UNLESS OTHERWISE DIRECTED BY THE ENGINEER. \*THE DISTANCE FROM END OF BRIDGE RAIL TO CENTER LINE OF THE FIRST POST SHOULD BE 11 1/2" IF CONCRETE BACKWALL IS NOT PRESENT. -SHOULDER BERM GUTTER MUST BE INSTALLED TO THE LIMITS 8' x 4" LIP CURB IS SHOWN IF ANCHOR UNIT IS NOT ADJACENT TO AN APPROACH SLAB. -MEASURE GUARDRAIL HEIGHT FROM THE TOP OF ADJACENT SURFACE (SHOULDER, BERM, OR GUTTER). -LAP JOINTS IN THE DIRECTION OF TRAFFIC FLOW. -SEE SHEET 3 FOR POST SECTIONS 1 THRU 9.

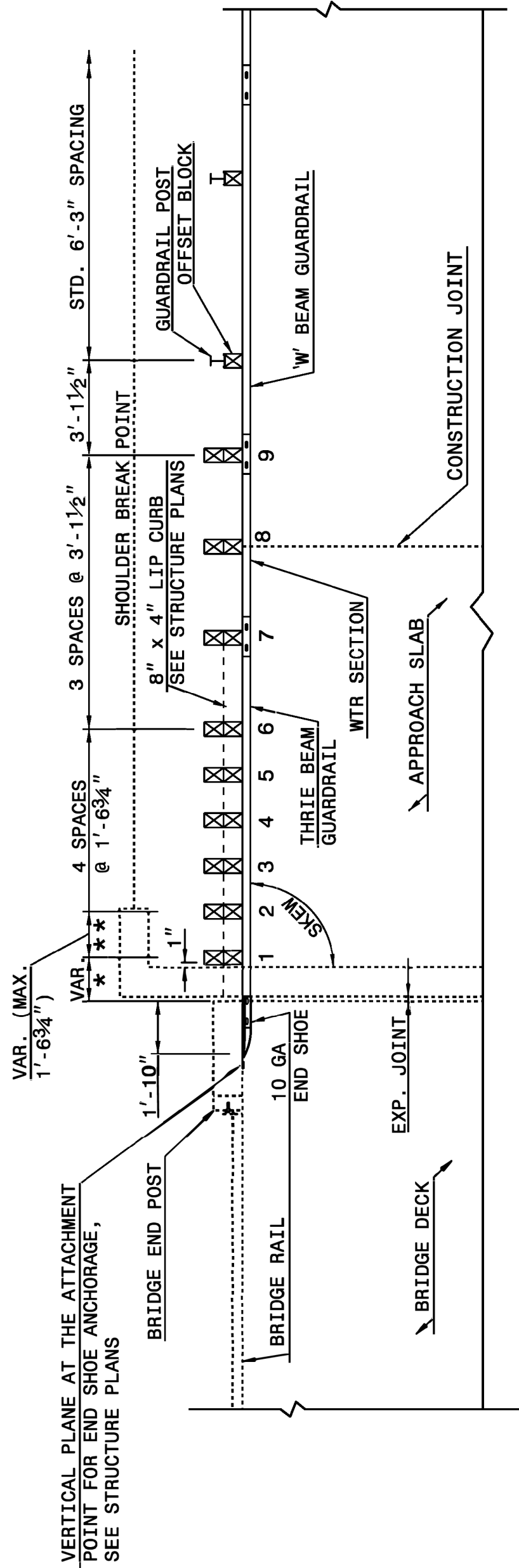

PLAN VIEW

GUARDRAIL ANCHOR UNIT, TYPE III FOR ATTACHMENT TO RAIL ON BRIDGE

STATE OF NORTH CAROLINA DEPT. OF TRANSPORTATION DIVISION OF HIGHWAYS RALEIGH, N.C.

ROADWAY DETAIL DRAWING FOR STRUCTURE ANCHOR UNITS GUARDRAIL ANCHOR UNIT, TYPE III FOR ATTACHMENT TO RAIL ON BRIDGE

SHEET 1 OF 7 862D03

STATE OF NORTH CAROLINA DEPT. OF TRANSPORTATION DIVISION OF HIGHWAYS RALEIGH, N.C.

ROADWAY DETAIL DRAWING FOR STRUCTURE ANCHOR UNITS GUARDRAIL ANCHOR UNIT, TYPE III FOR ATTACHMENT TO RAIL ON BRIDGE - SUB REGIONAL TIER

SHEET 2 OF 7 862D03

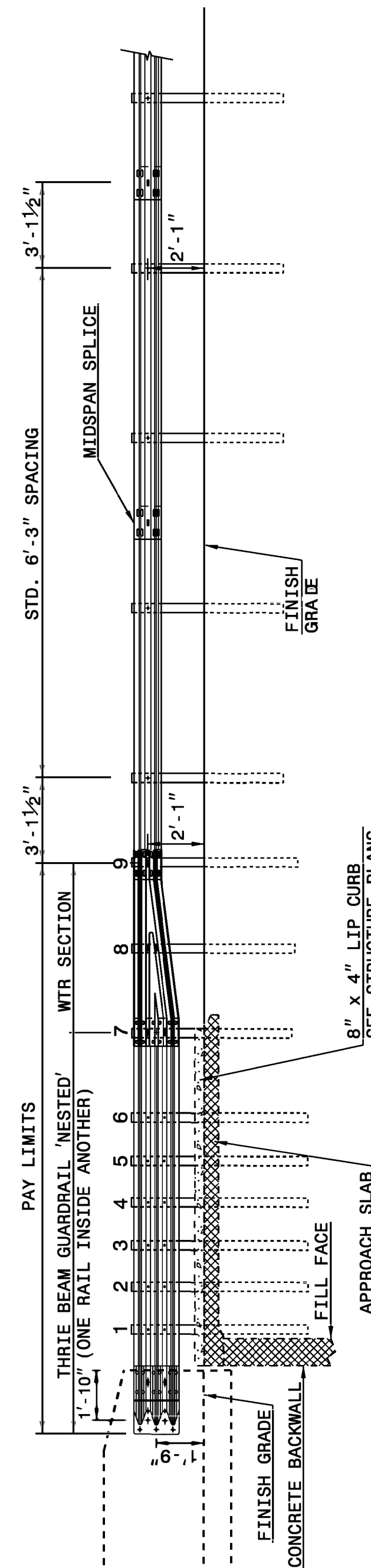

ELEVATION

NOTE: \*\*POST NOT REQUIRED FOR SKEW ANGLES GREATER THAN 150° OR LESS THAN 30° UNLESS OTHERWISE DIRECTED BY THE ENGINEER. \*THE DISTANCE FROM END OF BRIDGE RAIL TO CENTER LINE OF THE FIRST POST SHOULD BE 11 1/2" IF CONCRETE BACKWALL IS NOT PRESENT. -SHOULDER BERM GUTTER MUST BE INSTALLED TO THE LIMITS 8' x 4" LIP CURB IS SHOWN IF ANCHOR UNIT IS NOT ADJACENT TO AN APPROACH SLAB. -MEASURE GUARDRAIL HEIGHT FROM THE TOP OF ADJACENT SURFACE (SHOULDER, BERM, OR GUTTER). -LAP JOINTS IN THE DIRECTION OF TRAFFIC FLOW. -SEE SHEET 3 FOR POST SECTIONS 1 THRU 9.

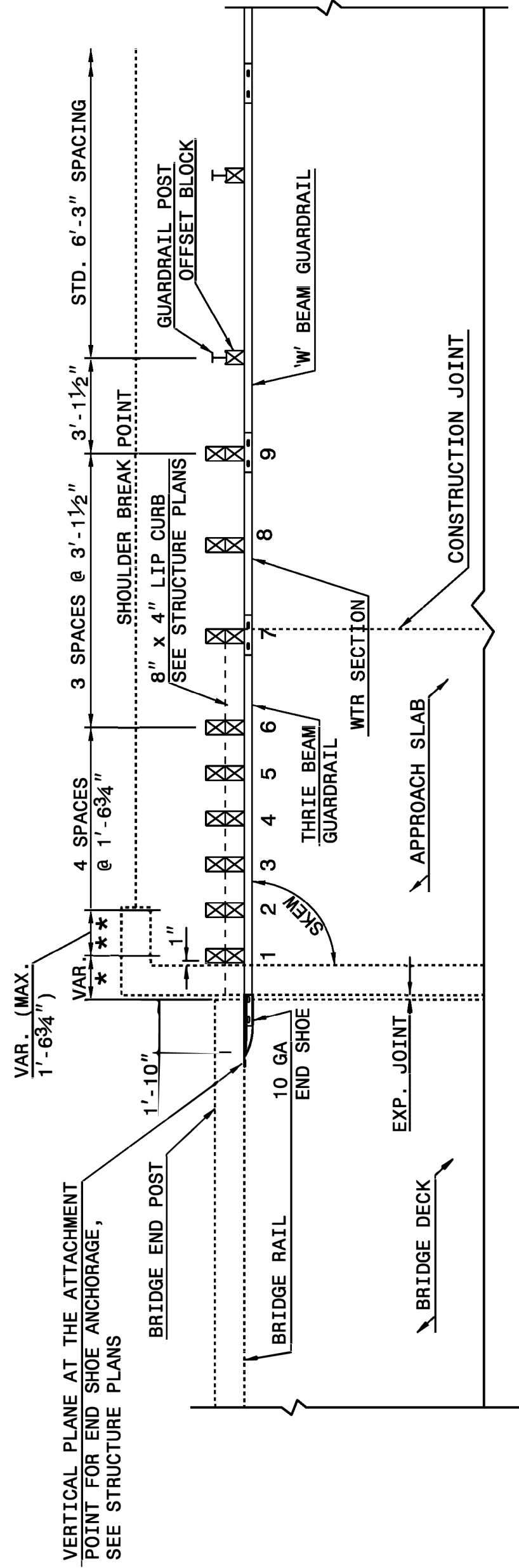

PLAN VIEW

GUARDRAIL ANCHOR UNIT, TYPE III FOR ATTACHMENT TO RAIL ON BRIDGE - SUB REGIONAL TIER

STATE OF NORTH CAROLINA DEPT. OF TRANSPORTATION DIVISION OF HIGHWAYS RALEIGH, N.C.

ROADWAY DETAIL DRAWING FOR STRUCTURE ANCHOR UNITS GUARDRAIL ANCHOR UNIT, TYPE III FOR ATTACHMENT TO RAIL ON BRIDGE - SUB REGIONAL TIER

SHEET 2 OF 7 862D03

PROJECT REFERENCE NO. SHEET NO.

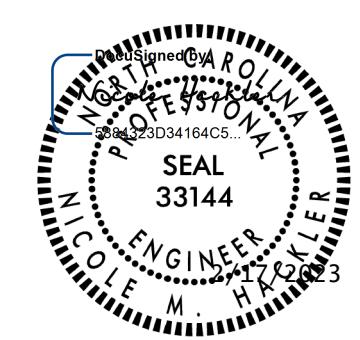

CONTRACT STANDARDS AND DEVELOPMENT UNIT Office 919-707-6950 FAX 919-250-4119 SEE TITLE BLOCK ORIGINAL BY: J. HOWERTON DATE: 06-22-12 MODIFIED BY: DATE: CHECKED BY: DATE: FILE SPEC.: DATE:

BR-0073 4RD1 2C-2 ROADWAY DESIGN ENGINEER DOCUMENT NOT CONSIDERED FINAL UNLESS ALL SIGNATURES COMPLETED STATE OF NORTH CAROLINA ROADWAY DESIGN UNIT PREPARED BY WSP 434 FAYETTEVILLE ST. #1500 RALEIGH, NC 27601 NC ENG P-1253

5/26/20

### SUMMARY OF BREAKING EXISTING ASPHALT PAVEMENT

SURVEY LINE	STATION	STATION	LOCATION L/R/T/CL	YD'
-L-	16+00.00	17+10.00	CL/RT	276.97
-L-	19+40.00	20+50.00	LT/CL	275.16
TOTAL:				552.13
SAY:				580

### ASPHALT PAVEMENT REMOVAL SUMMARY

SURVEY LINE	STATION	STATION	LOCATION L/R/T/CL	YD'
-L-	15+00.00	16+00.00	CL	248.25
-L-	17+10.00	17+59.00	CL	109.68
-L-	18+92.00	19+40.00	CL	106.05
-L-	20+50.00	21+00.00	CL	123.77
TOTAL:				587.75
SAY:				620

### SHOULDER BERM GUTTER SUMMARY

SURVEY LINE	STATION	STATION	LENGTH
-L-	16+36.66(LT)	17+11.47(LT)	74.81
-L-	19+23.87(LT)	19+33.86(LT)	9.99
TOTAL:			84.80
SAY:			90

### SUMMARY OF EARTHWORK (VOLUMES IN CY)

LINE	STATION	STATION	UNCL. EXCAV.	EMBANK. +%	BORROW	WASTE
		(BEG. BRIDGE)				
-L-	12+30.00	17+42.00	138	2,665	2,527	
-DR1-	10+14.00	12+55.71	13	844	831	
SUBTOTALS:			151	3,509	3,358	
	(END BRIDGE)					
-L-	19+07.00	23+17.00	168	3,766	3,598	
SUBTOTALS:			168	3,766	3,598	
TOTALS:			319	7,275	6,956	
MATERIAL FOR SHOULDER CONSTRUCTION				356	356	
PROJECT TOTALS:			319	7,631	7,312	
EST. 5% TO REPLACE TOPSOIL ON BORROW PIT					366	
GRAND TOTALS:			319	7,631	7,678	
SAY:				350	8,450	

PAVEMENT STRUCTURE VOLUME = 1,195 CY  
PER GEOTECH RECOMMENDATIONS DATED FEB. 2,2022, ESTIMATED 300 CUBIC YARDS OF UNDERCUT TO BE USED AT THE DISCRETION OF THE RESIDENT ENGINEER.

Note: Earthwork quantities are calculated by WSP USA E&I, Inc. These earthwork quantities are based in part on subsurface data provided by the Geotechnical Engineering Unit.

Note: Approximate quantities only. Clearing and Grubbing, Unclassified Excavation, Fine Grading, Removal of Existing Asphalt Pavement, and Breaking of Existing Asphalt Pavement will be paid for at the contract lump sum price for "Grading."

"N" = DISTANCE FROM EDGE OF LANE TO FACE OF GUARDRAIL.  
TOTAL SHOULDER WIDTH = DISTANCE FROM EDGE OF TRAVEL LANE TO SHOULDER BREAK POINT.  
FLARE LENGTH = DISTANCE FROM LAST SECTION OF PARALLEL GUARDRAIL TO END OF GUARDRAIL.  
W = TOTAL WIDTH OF FLARE FROM BEGINNING OF TAPER TO END OF GUARDRAIL.  
G = GATING IMPACT ATTENUATOR TYPE 350  
NG = NON-GATING IMPACT ATTENUATOR TYPE 350

### GUARDRAIL SUMMARY

SURVEY LINE	BEG. STA.	END STA.	LOCATION	LENGTH			WARRANT POINT		"N" DIST. FROM E.O.L.	TOTAL SHOUL. WIDTH	FLARE LENGTH		W		ANCHORS						IMPACT ATTENUATOR TYPE 350			SINGLE FACED GUARDRAIL	REMOVE EXISTING GUARDRAIL	REMOVE AND STOCKPILE EXISTING GUARDRAIL	REMARKS
				STRAIGHT	SHOP CURVED	DOUBLE FACED	APPROACH END	TRAILING END			APPROACH END	TRAILING END	GREU TL-3	III	B-77	CAT-1	AT-1	EA	G	NG							
-L-	14+39.135	17+49.51	RT	310.375			17+49.51		8	11	50		1				1								270.7		
-L-	15+86.565	17+34.44	LT	147.875				17+34.44	8	11	125						1								101.8		
-L-	18+98.85	22+09.225	LT	310.375			18+98.85		8	11	50		1				1								303.0		
-L-	19+15.10	22+87.975	RT	372.875				19+15.10	8	11	50		1				1								127.0		
SUBTOTALS				1,141.500													4									802.5	
ANCHOR DEDUCTIONS:																											
				4 B-77 @ 22.875																							
				4 GREU @ 50.00																							
TOTALS:				850.00														4								825.0	
SAY:				875.00													4										
ADDITIONAL GUARDRAIL POSTS = 5 EA																											

DOCUMENT NOT CONSIDERED FINAL UNLESS ALL SIGNATURES COMPLETED

STATE OF NORTH CAROLINA

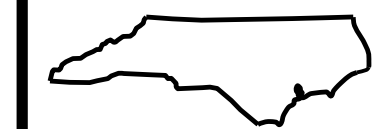

ROADWAY DESIGN UNIT

PREPARED BY



434 FAYETTEVILLE ST. #1500  
RALEIGH, N.C. 27601  
NC ENG P-1253

PRELIMINARY PLANS  
DO NOT USE FOR CONSTRUCTION





**STATE OF NORTH CAROLINA  
 DIVISION OF HIGHWAYS**

SUMMARY OF SUBSURFACE DRAINAGE

LINE	Station	Station	Location LT/RT/CL	Drain Type* UD/BD/SD	LF
CONTINGENCY				SD	200
				<b>TOTAL LF:</b>	200

\*UD = Underdrain  
 \*BD = Blind Drain  
 \*SD = Subsurface Drain

SUMMARY OF GEOTEXTILE  
 FOR PAVEMENT STABILIZATION

LINE	Station	Station	Geotextile for Pavement Stabilization SY	Class IV Subgrade Stabilization TONS
CONTINGENCY				
			<b>TOTAL SY/TONS:</b>	0 0*

\*Total tons of "Class IV Subgrade Stabilization" is only the estimated quantity for pavement stabilization and may only represent a portion of the subgrade stabilization quantity shown in the Item Sheets of the Proposal.

SUMMARY OF AGGREGATE SUBGRADE/STABILIZATION

LINE	Station	Station	Aggregate Type* ASU(1/2)/ AST	Aggregate Thickness INCHES [8" for ASU(2)]	Shallow Undercut CY	Class IV Subgrade Stabilization TONS	Geotextile for Soil Stabilization SY	Stabilizer Aggregate TONS	Class IV Aggregate Stabilization TONS
CONTINGENCY									
			<b>TOTAL CY/TONS/SY:</b>		0	0**	0**	0	0

\*ASU(1/2) = Aggregate Subgrade (Type 1 or 2)  
 \*AST = Aggregate Stabilization  
 \*\*Total tons of "Class IV Subgrade Stabilization" and total square yards of "Geotextile for Soil Stabilization" are only the estimated quantities for ASU(1/2)/AST and may only represent a portion of the subgrade stabilization and geotextile quantities shown in the Item Sheets of the Proposal.

SUMMARY OF ROCK PLATING

LINE	Beginning Slope (H:V)	Approx. Station	Ending Slope (H:V)	Approx. Station	Location LT/RT	Rock Plating Detail No. 1/2/3/4	Riprap Class* 1/2/B	Rock Plating SY
							<b>TOTAL SY:</b>	0

\*Use Class 1, 2 or B riprap if riprap class is not shown for rock plating location.

SUMMARY OF REINFORCED SOIL SLOPES AND SLOPE EROSION CONTROL

LINE	Beginning Slope/ RSS (H:V)	Approx. Station	Ending Slope/ RSS (H:V)	Approx. Station	Location LT/RT	Reinforced Soil Slope (RSS) SY	Geocells SY	Coir Fiber Mat SY	Matting for Erosion Control SY
						<b>TOTAL SY:</b>	0	0	0* 0**

\*Total square yards of "Coir Fiber Mat" is only the estimated quantity for slopes steeper than 2:1 (H:V) and may only represent a portion of the coir fiber mat quantity shown in the Item Sheets of the Proposal.  
 \*\*Total square yards of "Matting for Erosion Control" is only the estimated quantity for RSS and may only represent a portion of the matting quantity shown in the Item Sheets of the Proposal.

SUMMARY OF PRE-SPLITTING OF ROCK

LINE	Beginning Rock Cut Slope (H:V)	Approx. Station	Ending Rock Cut Slope (H:V)	Approx. Station	Location LT/RT	Pre-splitting of Rock SY
					<b>TOTAL SY:</b>	0

SUMMARY OF SURCHARGES  
 AND SURCHARGE WAITING PERIODS

LINE	Station	Station	Surcharge Height FT	MONTHS

SUMMARY OF EMBANKMENT  
 WAITING PERIODS

LINE	Station	Station	MONTHS

SUMMARY OF  
 SETTLEMENT GAUGES

Gauge No.	LINE and Station	Offset	
		Distance FT	Direction LT/RT
<b>TOTAL GAUGES (EACH):</b>			

SUMMARY OF BRIDGE WAITING PERIODS

Bridge Description	End Bent/ Bent No.	MONTHS



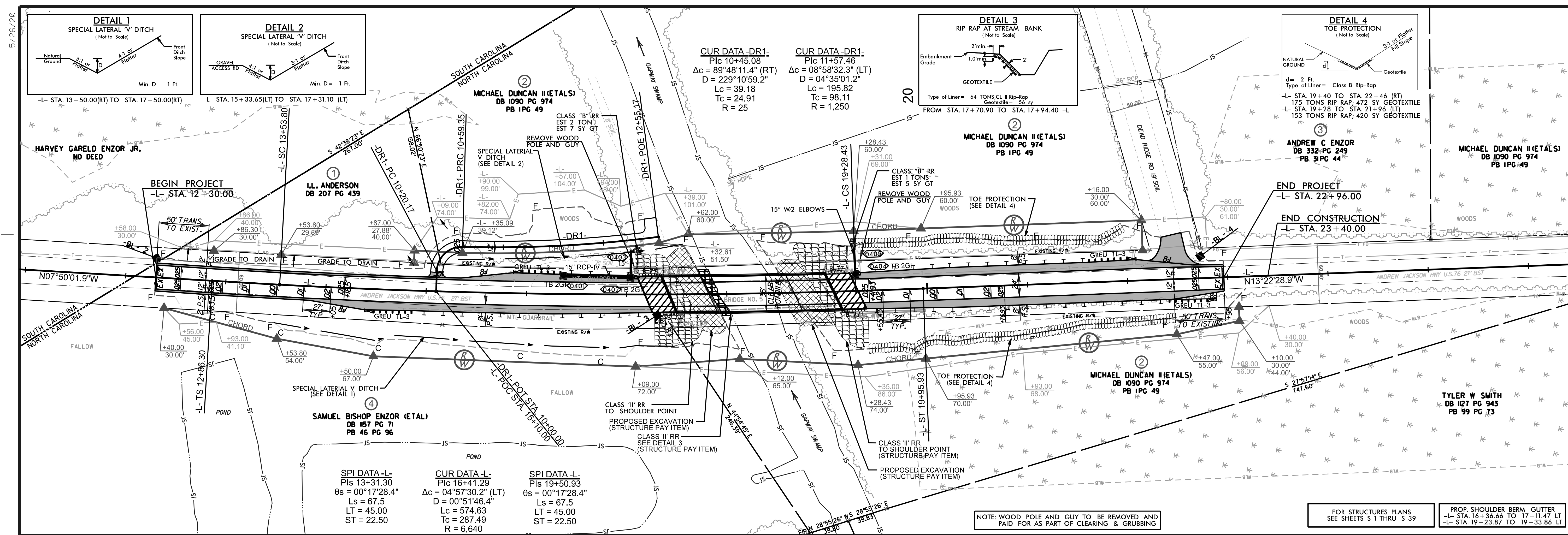

**BR-0073**  
 4RDI 004  
 ROADWAY DESIGN ENGINEER

STATE OF NORTH CAROLINA  
 ENGINEER  
 047089  
 CHRISTOPHER H. LEE

HYDRAULICS ENGINEER

STATE OF NORTH CAROLINA  
 ENGINEER  
 SEAL 29185  
 RICHARD L. HINER

DOCUMENT NOT CONSIDERED FINAL UNLESS ALL SIGNATURES COMPLETED  
 STATE OF NORTH CAROLINA

ROADWAY DESIGN UNIT

PREPARED BY  
**wsp**  
 434 FAYETTEVILLE ST. #1500  
 RALEIGH, N.C. 27601  
 NC ENG P-1253

PRELIMINARY PLANS  
 DO NOT USE FOR CONSTRUCTION

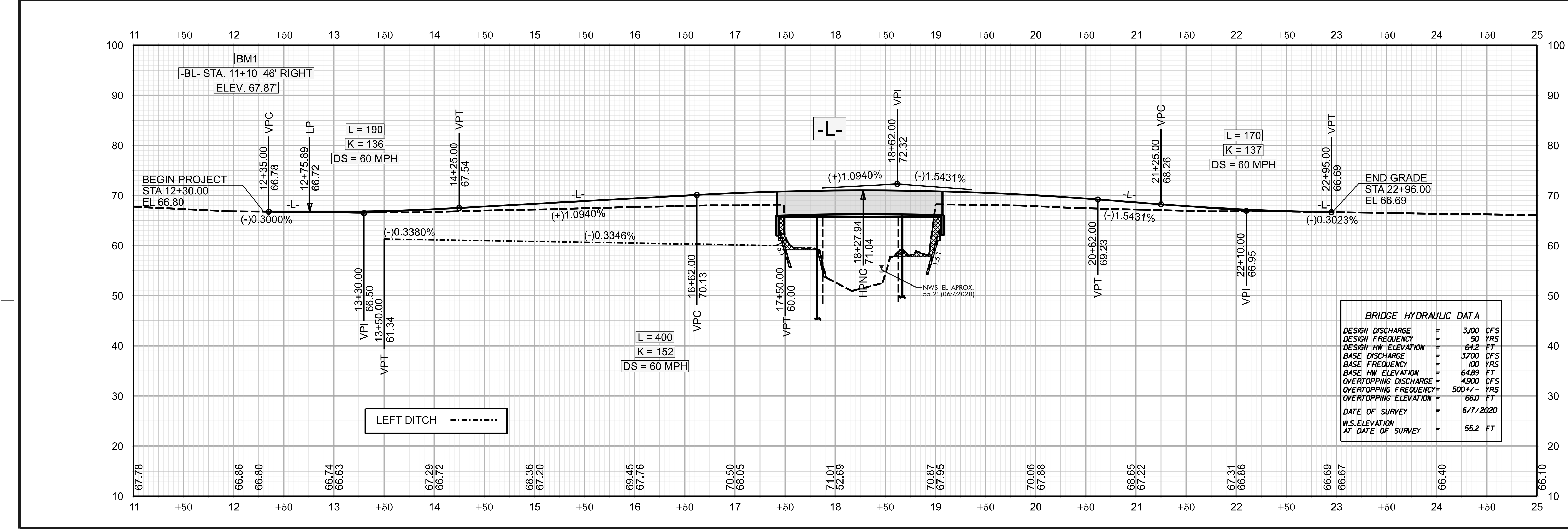

REVISIONS