

EXISTING SECTION AT BENT
SECTION D-D

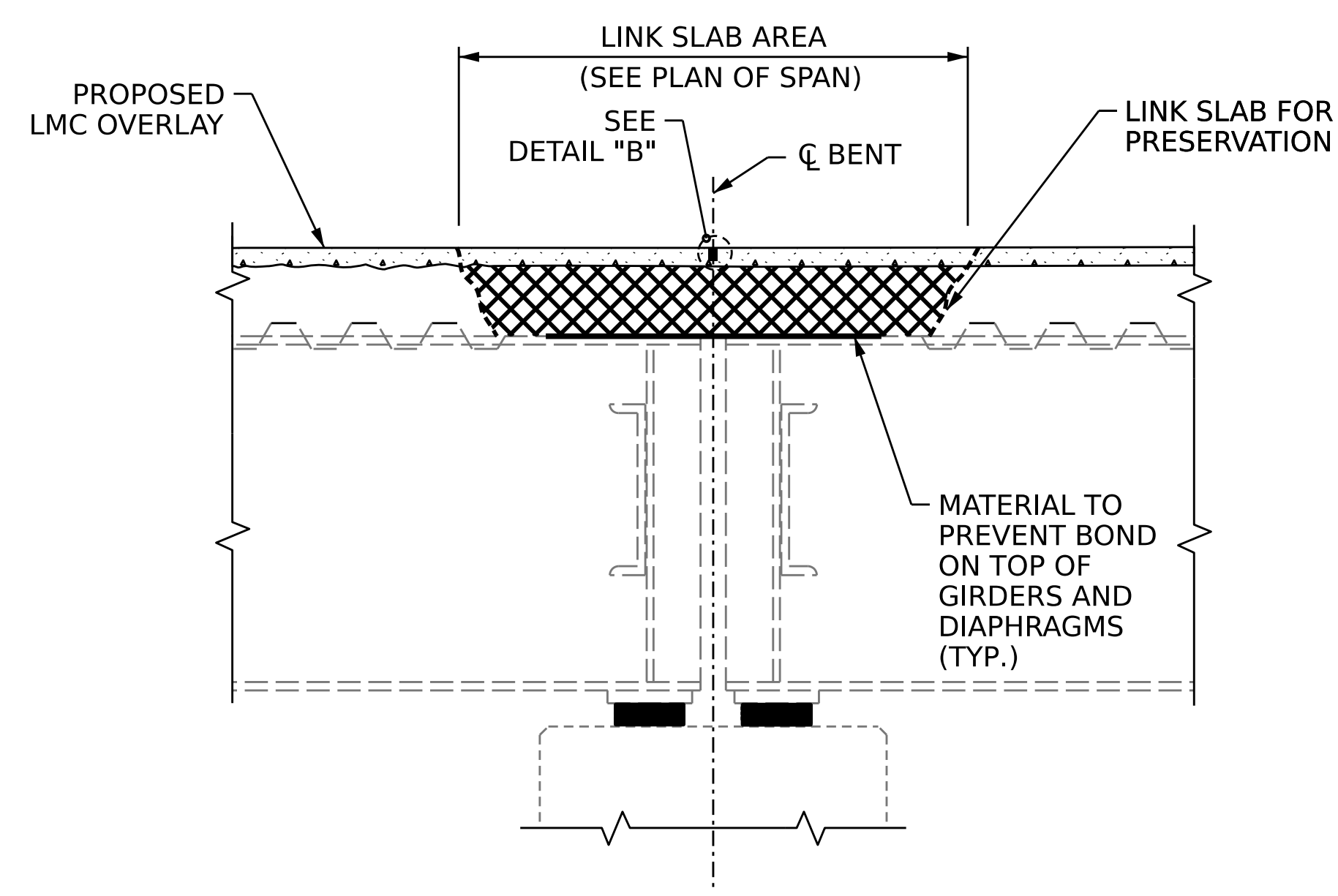

PROPOSED SECTION AT BENT
SECTION D-D

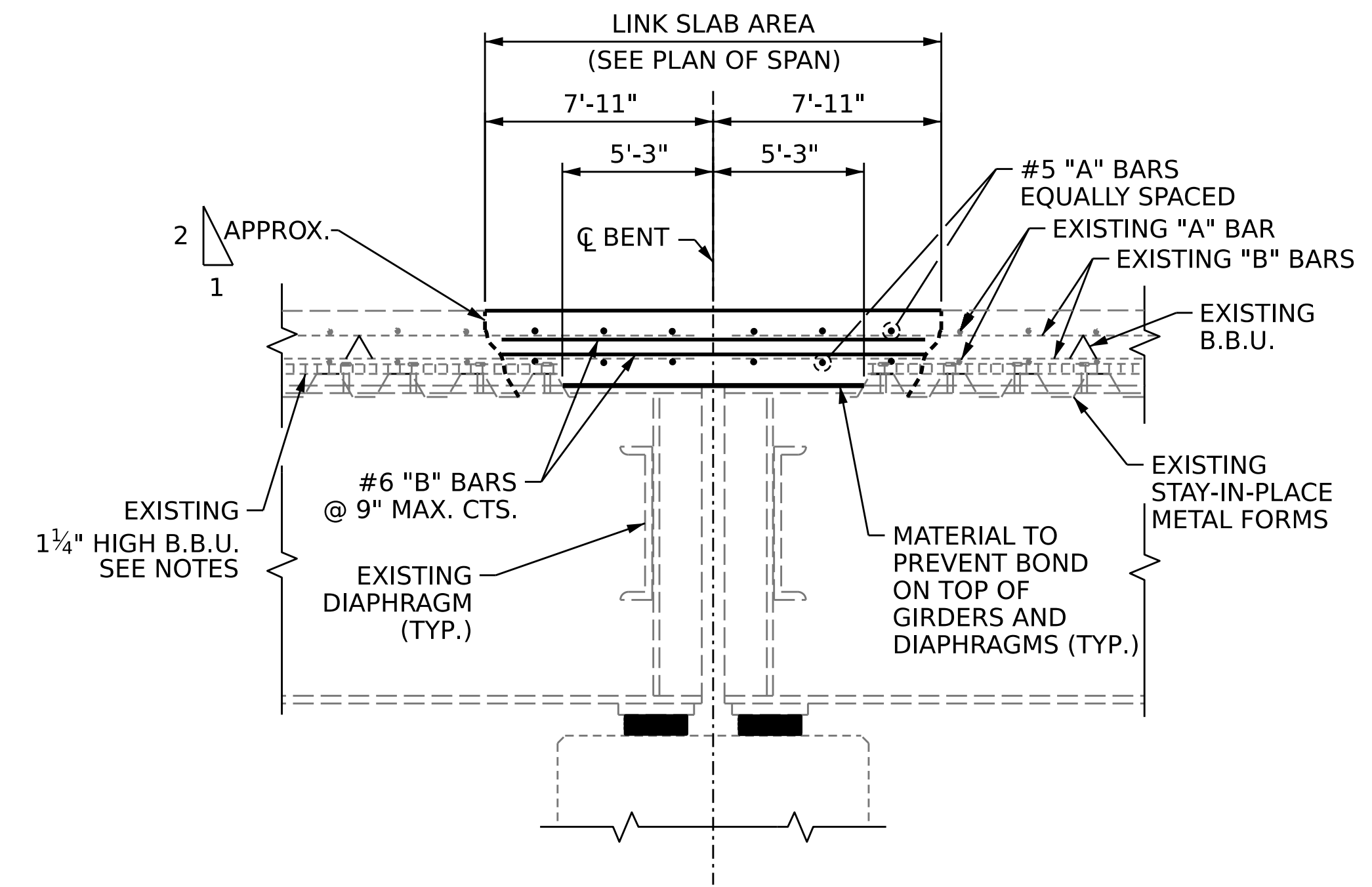
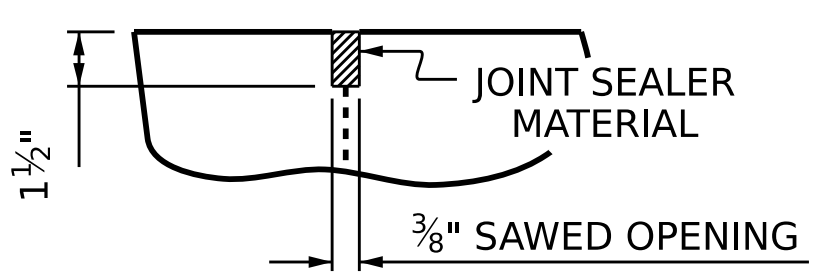

DETAIL "B"

A 1 1/2" DEEP CONTRACTION JOINT AT BENT CONTROL LINE SHALL BE SAWN WITHIN 24 HOURS OF POURING THE LINK SLAB AND OVERLAY. THE JOINT SHALL BE FILLED WITH JOINT SEALER MATERIAL. THE JOINT SEALER MATERIAL SHALL CONFORM TO THE REQUIREMENTS OF TYPE B LOW MODULUS SILICONE SEALANT. SEE SECTION 1028 OF THE STANDARD SPECIFICATIONS.

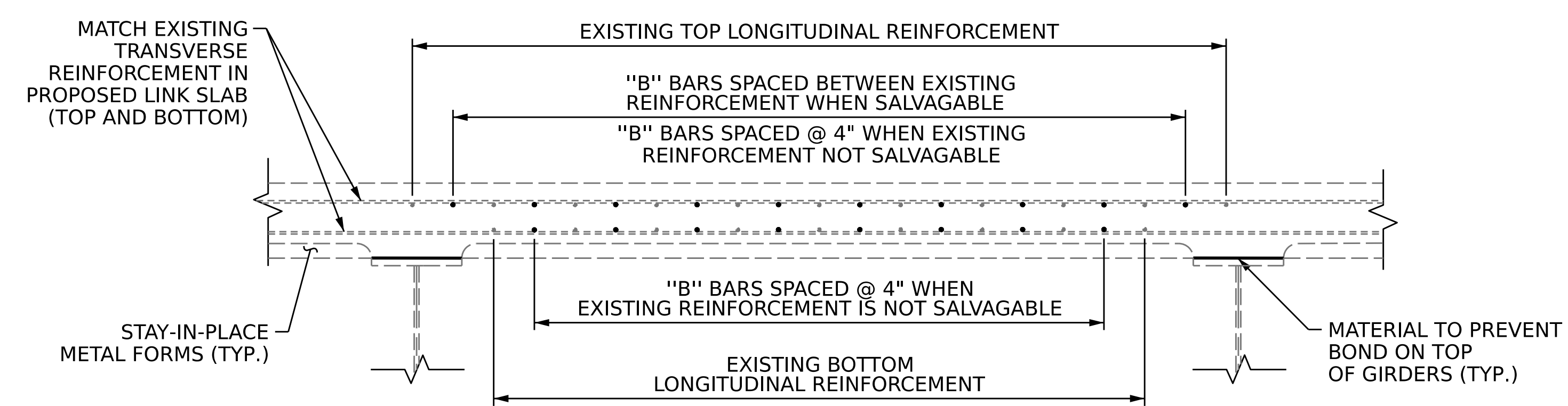

REINFORCEMENT DETAILS

SPLICE LENGTHS			
BAR SIZE	EPOXY COATED	UNCOATED	
#4	2'-0"	1'-9"	
#5	2'-6"	2'-2"	
#6	3'-0"	2'-7"	

BILL OF MATERIAL					
LINK SLAB AT BENT 3					
BAR NO.	NO.	SIZE	TYPE	LENGTH	WEIGHT
* A	27	#5	STR	39'-8"	1117 LBS.
A	27	#5	STR	39'-8"	1117 LBS.
* B	74	#6	STR	15'-6"	1723 LBS.
B	74	#6	STR	15'-6"	1723 LBS.
REINFORCING STEEL				2840 LBS.	
* EPOXY COATED REINFORCING STEEL				2840 LBS.	
CLASS AA CONCRETE				C.Y.	17.1

NOTES

- SEE TRAFFIC MANAGEMENT PLANS FOR LANE WIDTHS, SEQUENCING, AND OTHER TRAFFIC CONTROL MEASURES FOR STAGING OF JOINT REPAIR.
- FOR ESTIMATED LINK SLAB FOR PRESERVATION QUANTITIES, SEE PLAN OF SPAN SHEETS.
- FOR LINK SLAB FOR PRESERVATION, SEE SPECIAL PROVISIONS.

CONSTRUCTION SEQUENCE

- CLOSE WORK AREA ACCORDING TO TRAFFIC MANAGEMENT PLANS.
- MARK OUT PROPOSED LINK SLAB AREA AND REMOVE EXISTING JOINT MATERIAL.
- SAW CUT 1/2" DEEP PERIMETER OF PROPOSED LINK SLAB AREA.
- BEGIN FULL DEPTH DEMOLITION OF PROPOSED LINK SLAB AREA, BEING CAREFUL NOT TO DAMAGE EXISTING REINFORCING STEEL, BEAM FLANGES, OR STAY-IN-PLACE FORMS. DEMOLISH EDGES OF LINK SLAB AREA AT A 2:1 RATIO, AS SHOWN.
- REMOVE DEMOLITIONED MATERIALS AND CLEAN LINK SLAB AREA.
- REMOVE SHEAR STUDS/STIRRUPS WITHIN THE LINK SLAB AREA.
- REPAIR EXISTING REINFORCING STEEL THAT WAS DAMAGED DURING DEMOLITION.
- PLACE BOND BREAKER MATERIAL WITHIN THE LINK SLAB AREA.
- PLACE ADDITIONAL REINFORCING STEEL AS SHOWN.
- PLACE NEW CONCRETE FOLLOWING THE CONCRETE WORK FOR JOINT REPLACEMENT SPECIAL PROVISION. AS AN ALTERNATIVE, THE CONTRACTOR CAN USE LMC MATERIAL FOR THE LINK SLAB, FOLLOWING THE LATEX MODIFIED CONCRETE BRIDGE DECK OVERLAY SPECIAL PROVISIONS.
- AFTER PROPOSED DECK OVERLAY WORK HAS CURED, SAW CUT CONTROL LINES AND FILL WITH SEALER MATERIAL.

PROJECT NO. **15BPR.61**
CHEROKEE COUNTY
 BRIDGE NO. **190010**

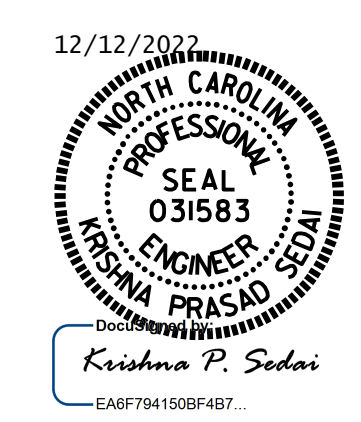

STATE OF NORTH CAROLINA
 DEPARTMENT OF TRANSPORTATION
 RALEIGH

LINK SLAB FOR PRESERVATION DETAILS @ BENT 3

DRAWN BY : S. A. HERNANDEZ DATE : 6/2020
 CHECKED BY : A. SORSENGINH DATE : 6/2020
 DESIGN ENGINEER OF RECORD : S. A. HERNANDEZ DATE : 6/2020

DOCUMENT NOT CONSIDERED FINAL UNLESS ALL SIGNATURES COMPLETED

REVISIONS				SHEET NO.
NO.	BY:	DATE:	NO.	DATE:
1			3	
2			4	

TOTAL SHEETS: 28