

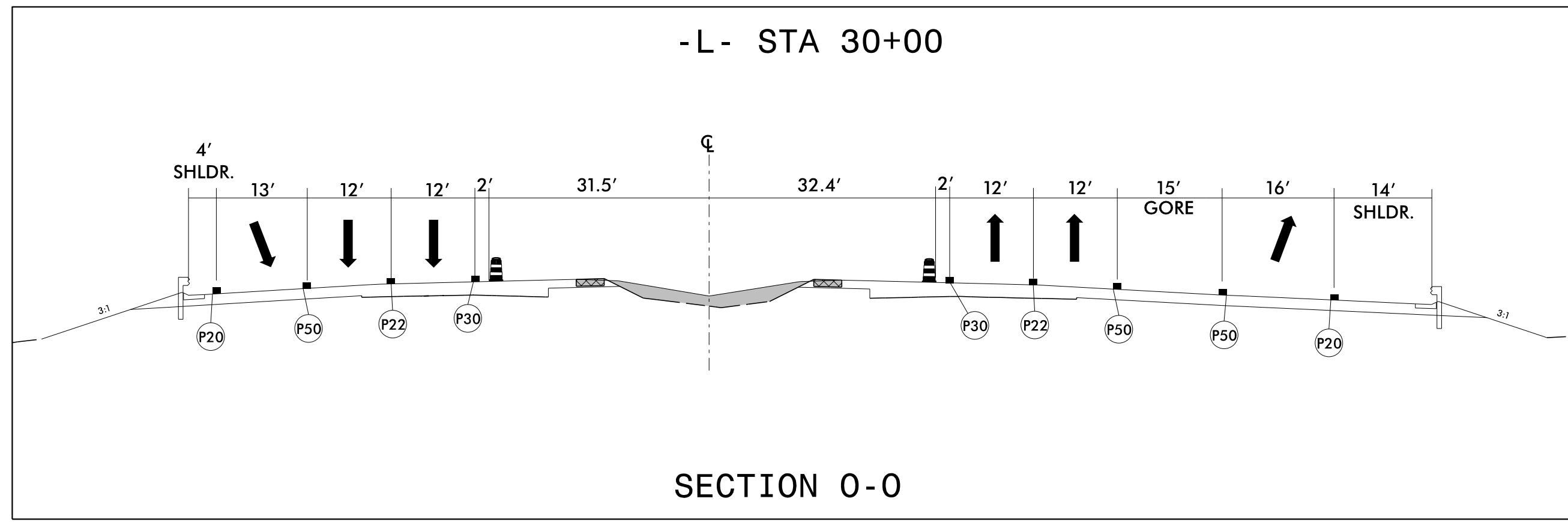

PROJ. REFERENCE NO.	SHEET NO.
R-5751	TMP-27

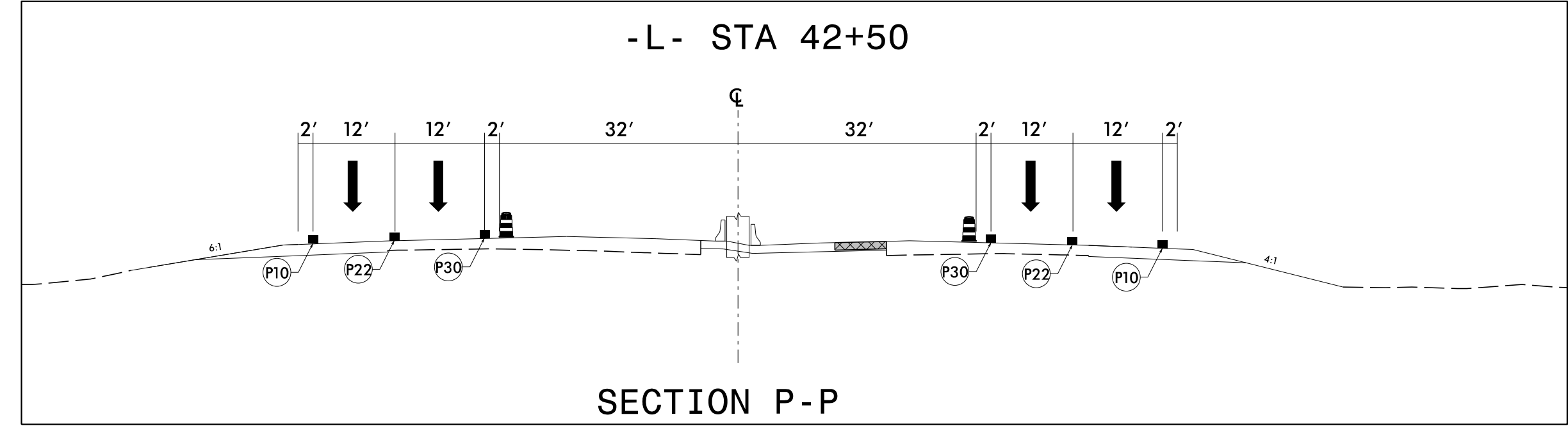
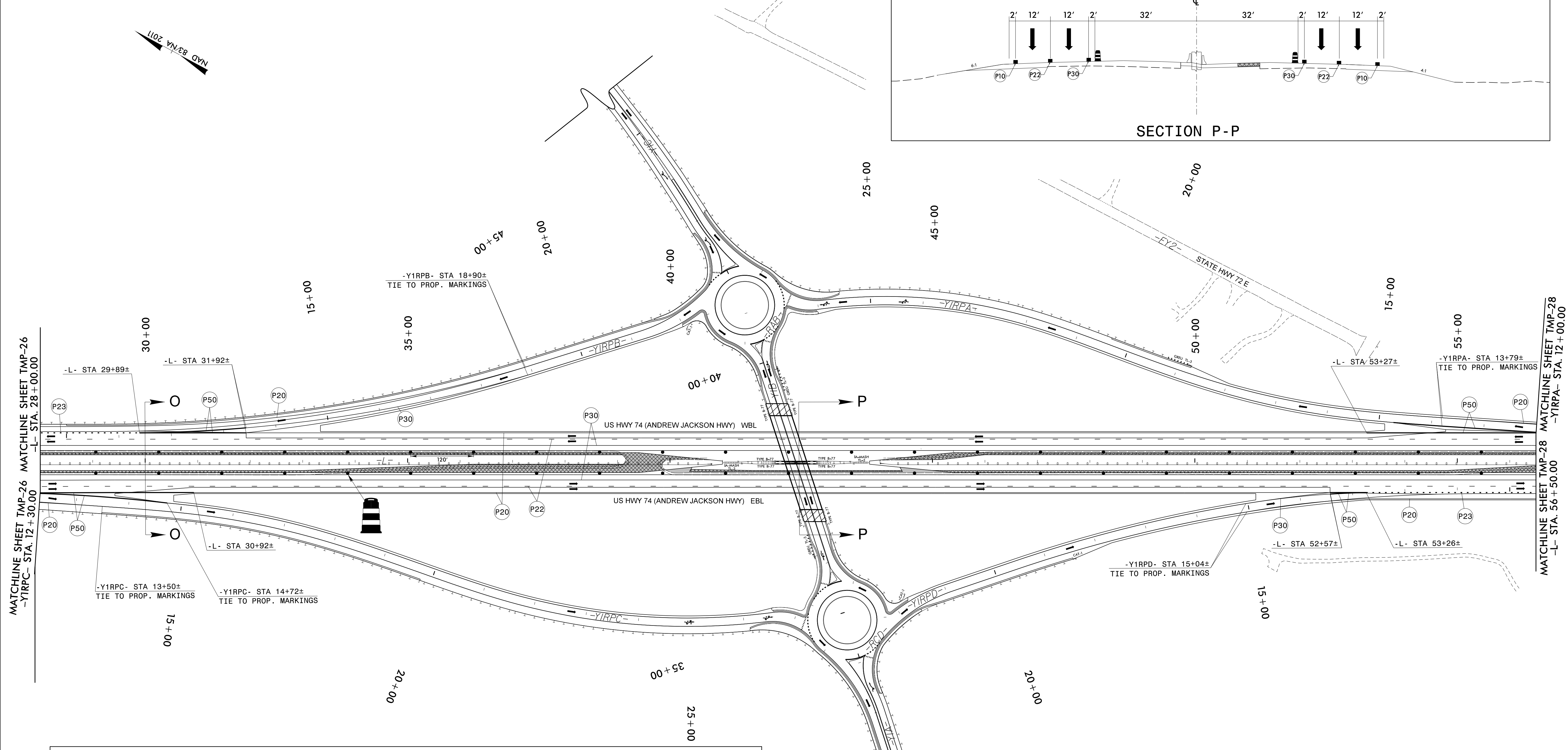

MATCHLINE SHEET TMP-26  
-YIRPC- STA. 12+30.00

MATCHLINE SHEET TMP-28  
-YIRPA- STA. 12+00.00

10/6/2022  
R:\TrafficControl\CPAR-5751\TC-TMP-pli-dtl-03.dgn  
User: Bondu



APPROVED: *Jared M. Bond*  
DATE: \_\_\_\_\_

DocuSign by: *Jared M. Bond*  
EF710591C74F469...

SEAL  
040418  
ENGINEER  
JARED M. BOND

**DOCUMENT NOT CONSIDERED FINAL  
UNLESS ALL SIGNATURES COMPLETED**

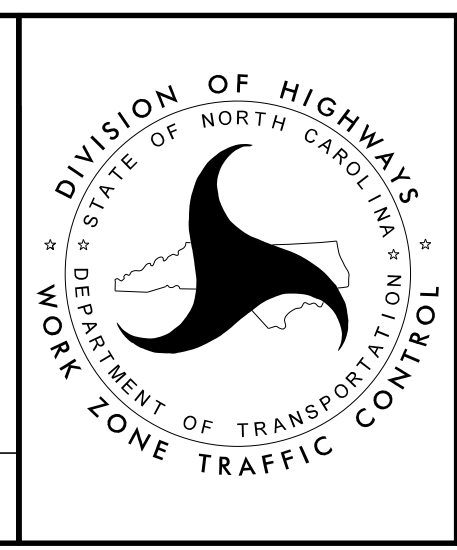

**PHASE III  
DETAIL**