

PROJ. REFERENCE NO.	SHEET NO.
R-5751	TMP-13

\*\* NOTE: SEE US 74 WB U-TURN DETOUR ROUTE (SHEET TMP-2) AND RSD 1101.03 (SHEET 1 AND 2 OF 9) FOR COMPLETE DETOUR SIGNING

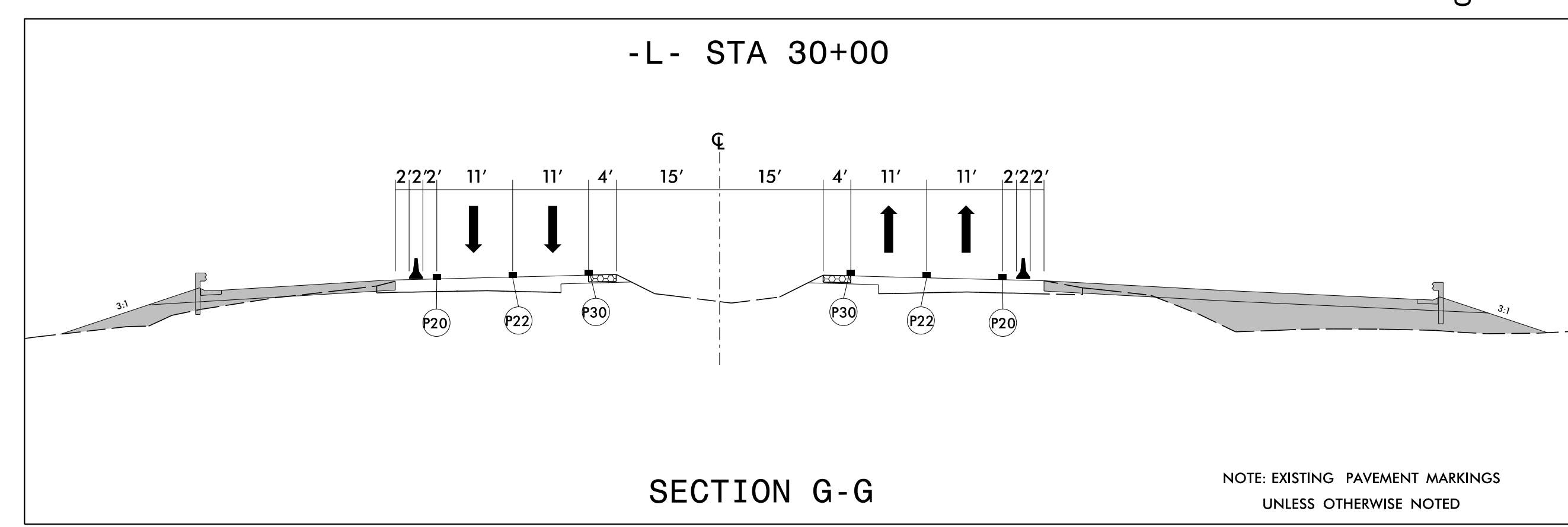
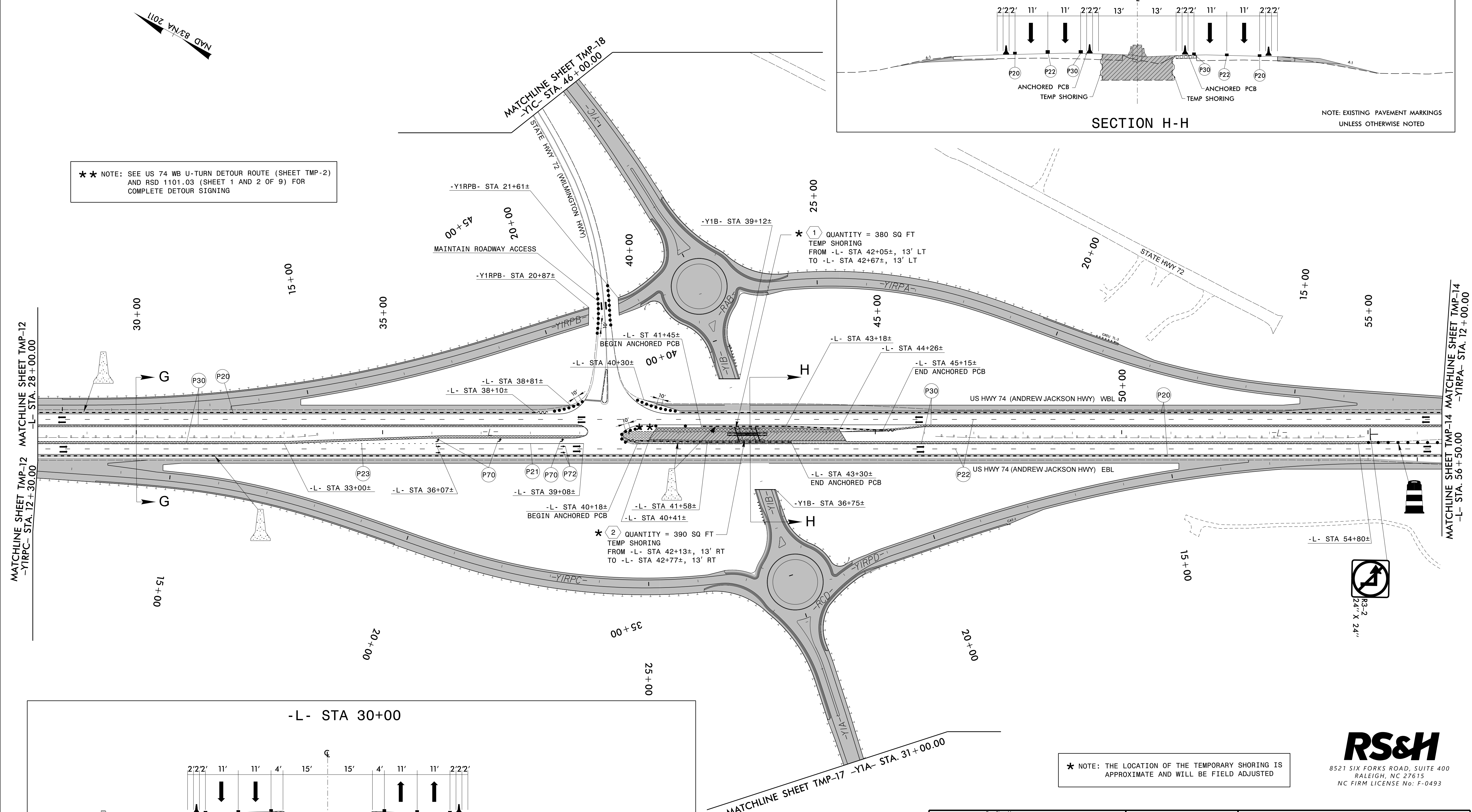
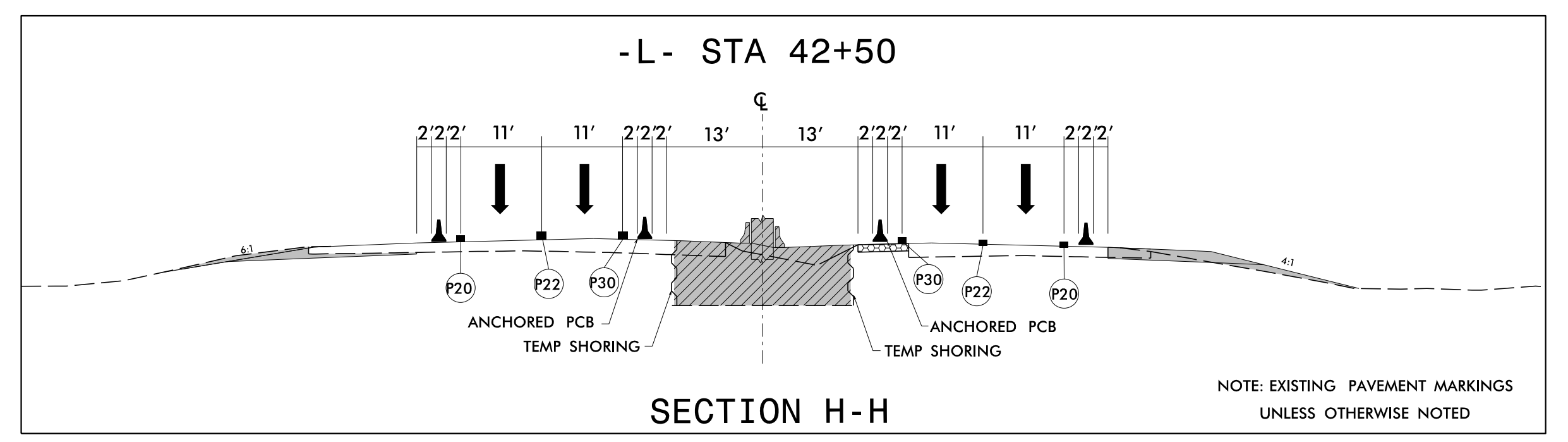

\* NOTE: THE LOCATION OF THE TEMPORARY SHORING IS APPROXIMATE AND WILL BE FIELD ADJUSTED

**RS&H**  
 8521 SIX FORKS ROAD, SUITE 400  
 RALEIGH, NC 27615  
 NC FIRM LICENSE No: F-0493

APPROVED: *Jared M. Bond*  
EF710591C74F469...

DATE: \_\_\_\_\_

**DOCUMENT NOT CONSIDERED FINAL UNLESS ALL SIGNATURES COMPLETED**

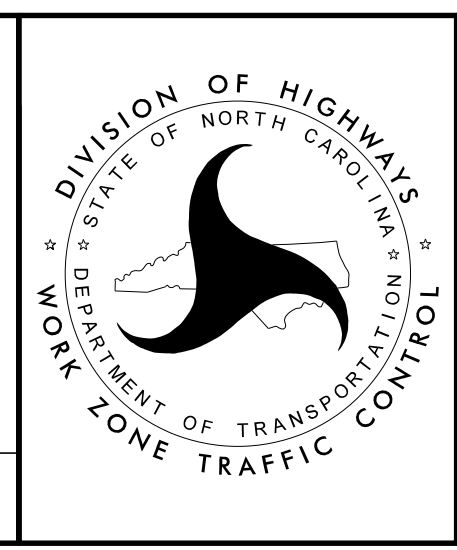

**PHASE II STEP 1 DETAIL**

Division of Highways  
 North Carolina  
 Department of Transportation  
 Work Zone Traffic Control

10/6/2022  
 R:\TrafficControl\CPAR-5751.LTC-TMP-pii-sl.dtl.03.dgn  
 User: BondJ