

**This electronic collection of documents is provided  
for the convenience of the user  
and is Not a Certified Document –**

**The documents contained herein were originally issued  
and sealed by the individuals whose names and license  
numbers appear on each page, on the dates appearing  
with their signature on that page.**

**This file or an individual page  
shall not be considered a certified document.**

**T.I.P.: I-5987A**

**CONTRACT NO.:**

**STATE OF NORTH CAROLINA  
DEPARTMENT OF TRANSPORTATION**

**PAVEMENT MARKING PLAN**

**ROBESON COUNTY**

**LOCATION: I-95 FROM SOUTH OF US 301 (EXIT 22) TO NORTH  
OF SR 1758 (MCDUFFIE CROSSING RD)**

<small>TIP NO.</small> <b>I - 5987A</b>	<small>SHEET NO.</small> <b>PMP - 1</b>
<small>APPROVED:</small> <i>William J. Hamilton</i> <small>ASSET ID: 04848484</small>	
<small>DATE:</small> <b>5/10/2022</b>	
	
<b>DOCUMENT NOT CONSIDERED FINAL UNLESS ALL SIGNATURES COMPLETED</b>	

**ROADWAY STANDARD DRAWING**

THE FOLLOWING ROADWAY STANDARDS AS APPEAR IN "ROADWAY STANDARD DRAWINGS" - PROJECT SERVICES UNIT - N.C. DEPARTMENT OF TRANSPORTATION - RALEIGH, N.C., DATED JANUARY 2018 ARE APPLICABLE TO THIS PROJECT AND BY REFERENCE HEREBY ARE CONSIDERED A PART OF THESE PLANS:

<u>STD. NO.</u>	<u>TITLE</u>
1205.01	PAVEMENT MARKINGS - LINE TYPES AND OFFSETS
1205.02	PAVEMENT MARKINGS - DIVIDED AND UNDIVIDED ROADWAYS
1205.03	PAVEMENT MARKINGS - INTERCHANGES
1205.04	PAVEMENT MARKINGS - INTERSECTIONS
1205.05	PAVEMENT MARKINGS - TURN LANES
1205.06	PAVEMENT MARKINGS - LANE DROPS
1205.07	PAVEMENT MARKINGS - PEDESTRIAN CROSSWALKS
1205.08	PAVEMENT MARKINGS - SYMBOLS AND WORD MESSAGES
1205.09	PAVEMENT MARKINGS - PAINTED ISLANDS
1205.12	PAVEMENT MARKINGS - BRIDGES
1205.14	PAVEMENT MARKINGS - ROUNDABOUTS
1250.01	RAISED PAVEMENT MARKERS - INSTALLATION SPACING
1251.01	RAISED PAVEMENT MARKERS - PERMANENT AND TEMPORARY
1253.01	RAISED PAVEMENT MARKERS - SNOWPLOWABLE
1261.01	GUARDRAIL AND BARRIER DELINEATORS - INSTALLATION SPACING
1261.02	GUARDRAIL AND BARRIER DELINEATORS - TYPES AND MOUNTING
1262.01	GUARDRAIL END DELINEATION
1264.01	OBJECT MARKERS - TYPES
1264.02	OBJECT MARKERS - INSTALLATION
1262.02	PLACEMENT OF OBJECT MARKERS

**GENERAL NOTES**

THE FOLLOWING GENERAL NOTES APPLY AT ALL TIMES FOR THE DURATION OF THE CONSTRUCTION PROJECT, EXCEPT WHEN OTHERWISE NOTED IN THE PLAN, OR DIRECTED BY THE ENGINEER.

- A) INSTALL PAVEMENT MARKINGS AND PAVEMENT MARKERS ON THE FINAL SURFACE AS FOLLOWS:
- | <u>ROAD NAME</u> | <u>MARKING</u> | <u>MARKER</u> |
|------------------|----------------|---------------|
| I-95             | THERMOPLASTIC  | SNOWPLOWABLE  |
| Y-LINES          | THERMOPLASTIC  | RAISED        |
- B) TIE PROPOSED PAVEMENT MARKING LINES TO EXISTING PAVEMENT MARKING LINES.  
 C) REMOVE/REPLACE ANY CONFLICTING/DAMAGED PAVEMENT MARKINGS AND MARKERS.  
 D) STOP BAR LOCATION AT NON-SIGNALIZED INTERSECTIONS MAY BE ADJUSTED AS DIRECTED BY THE ENGINEER.

**PLANS PREPARED BY:** *Ramey Kemp Associates*

**W. JASON HAMILTON, P.E., PTOE** PROJECT ENGINEER  
**TIMOTHY S. POPELKA, P.E.** PROJECT DESIGNER



**PAVEMENT MARKING SCHEDULE**

<u>SYMBOL</u>	<u>DESCRIPTION</u>
THERMOPLASTIC (4", 90 MILS)	
T1	WHITE EDGELINE
T2	WHITE SOLID LANE LINE
T4	3 FT. - 9 FT./SP WHITE MINISKIP
T5	2 FT. - 6 FT./SP WHITE MINISKIP
T10	YELLOW EDGELINE
T11	YELLOW SINGLE CENTER
T12	10 FT. YELLOW SKIP
T13	YELLOW DOUBLE CENTER
THERMOPLASTIC (6", 90 MILS)	
T20	WHITE EDGELINE
T22	10 FT. WHITE SKIP
T23	3 FT. - 9 FT./SP WHITE MINISKIP
T30	YELLOW EDGELINE
THERMOPLASTIC (8", 90 MILS)	
T40	WHITE GORELINE
THERMOPLASTIC (12", 90 MILS)	
T50	WHITE GORELINE
T52	YELLOW DIAGONAL
T54	3 FT. - 9 FT./SP WHITE MINISKIP
T55	3 FT. - 3 FT./SP WHITE MINISKIP
THERMOPLASTIC (24", 90 MILS)	
T61	WHITE STOPBAR
THERMOPLASTIC PAVEMENT MARKING SYMBOLS (90 MILS)	
T70	LEFT TURN ARROW
T71	RIGHT TURN ARROW
T75	COMBO. LEFT/RIGHT ARROW
T79	MERGE ARROW
T80	WRONG WAY RAMP ARROW
T100	ALPHANUMERIC CHAR.
T103	24" YIELD TRIANGLE
POLYUREA (4")	
V1	WHITE EDGELINE
V2	WHITE SOLID LANE LINE
V10	YELLOW EDGELINE
V13	YELLOW DOUBLE CENTER

**INDEX**

<u>SHEET NO.</u>	<u>DESCRIPTION</u>
PMP - 1	PAVEMENT MARKING PLAN COVER SHEET AND PAVEMENT MARKING SCHEDULE
PMP - 2 - 39	PAVEMENT MARKING DETAILS

TIP NO.	SHEET NO.
I - 5987A	PMP - 2
APPROVED: <i>William J. Hamilton</i>	
DATE: 5/10/2022	
SEAL	
DOCUMENT NOT CONSIDERED FINAL UNLESS ALL SIGNATURES COMPLETED	
RAMEY KEMP ASSOCIATES 5808 Faringdon Place Raleigh, North Carolina 27609 Phone: 919-872-5115 NC License No. C-0910 www.rameykemp.com	

CURB RAMP LOCATIONS (CENTER OF RAMP AT FACE OF CURB)	
1	-SR6- STA. 36+40
2	-SR6- STA. 37+33

NAD 83/NA 2011

BEGIN TIP PROJECT I-5987A  
 -L- STA. 67+00  
 TIE TO TIP PROJECT I-6064  
 -L- STA. XXX+XX

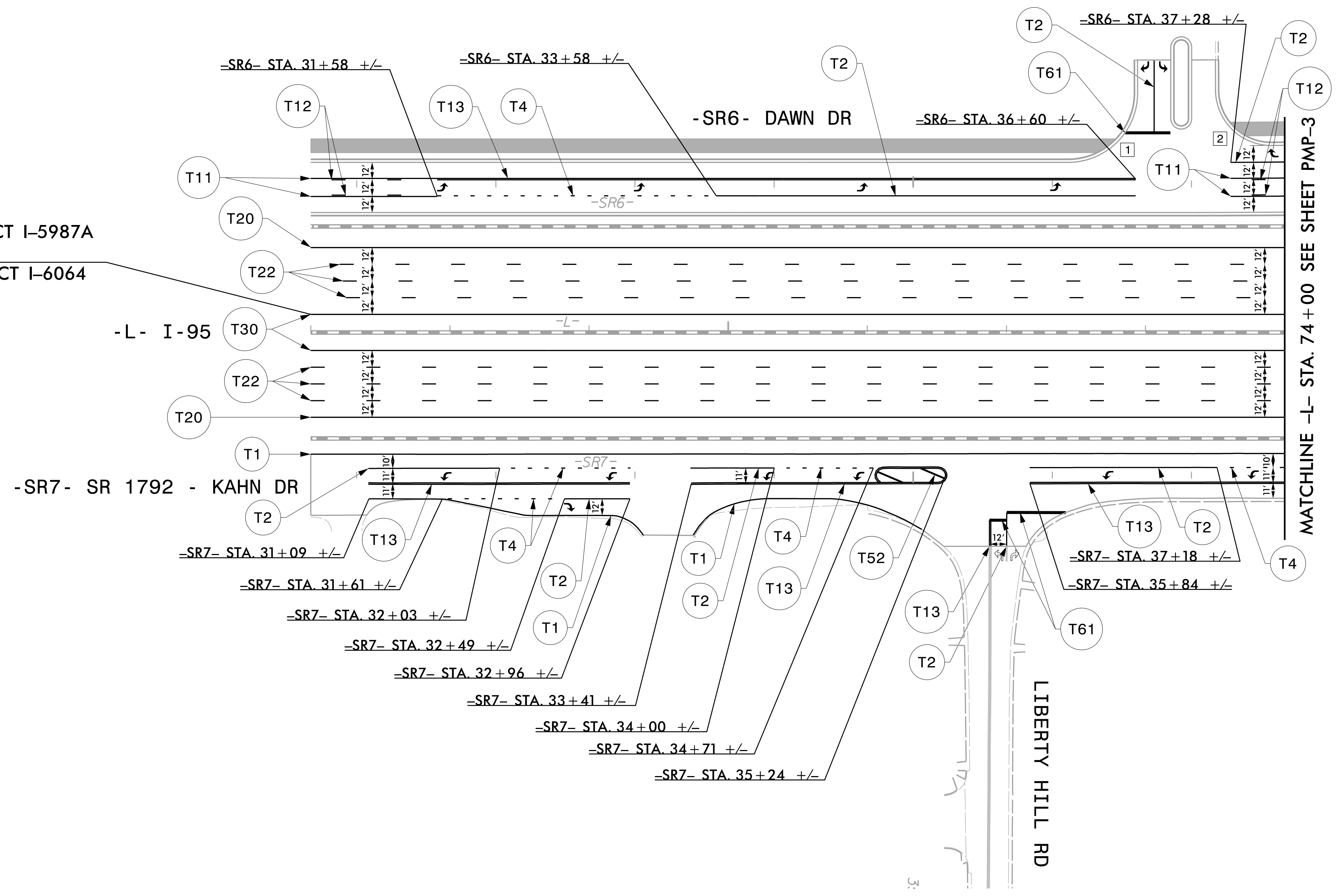

SYMBOL LEGEND	
	T70 LEFT ARROW
	T71 RIGHT ARROW

**PAVEMENT MARKING DETAIL**



CURB RAMP LOCATIONS (CENTER OF RAMP AT FACE OF CURB)			
3	-SR6- STA. 37+93	7	-SR6- STA. 42+52
4	-SR6- STA. 38+37	8	-SR6- STA. 43+09
5	-SR6- STA. 40+87	9	-SR6- STA. 45+14
6	-SR6- STA. 41+22	10	-SR6- STA. 45+68

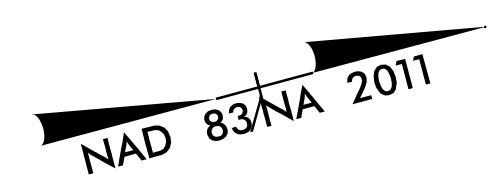

TIP NO. <b>I - 5987A</b>	SHEET NO. <b>PMP - 3</b>
Drawn by: <i>William J. Hamilton</i> APPROVED: <i>William J. Hamilton</i> DATE: <b>5/10/2022</b>	
SEAL 	
DOCUMENT NOT CONSIDERED FINAL UNLESS ALL SIGNATURES COMPLETED	
 <b>RAMEY KEMP ASSOCIATES</b> 5808 Faringdon Place Raleigh, North Carolina 27609 Phone: 919-872-5115 NC License No. C-0910 www.rameykemp.com	

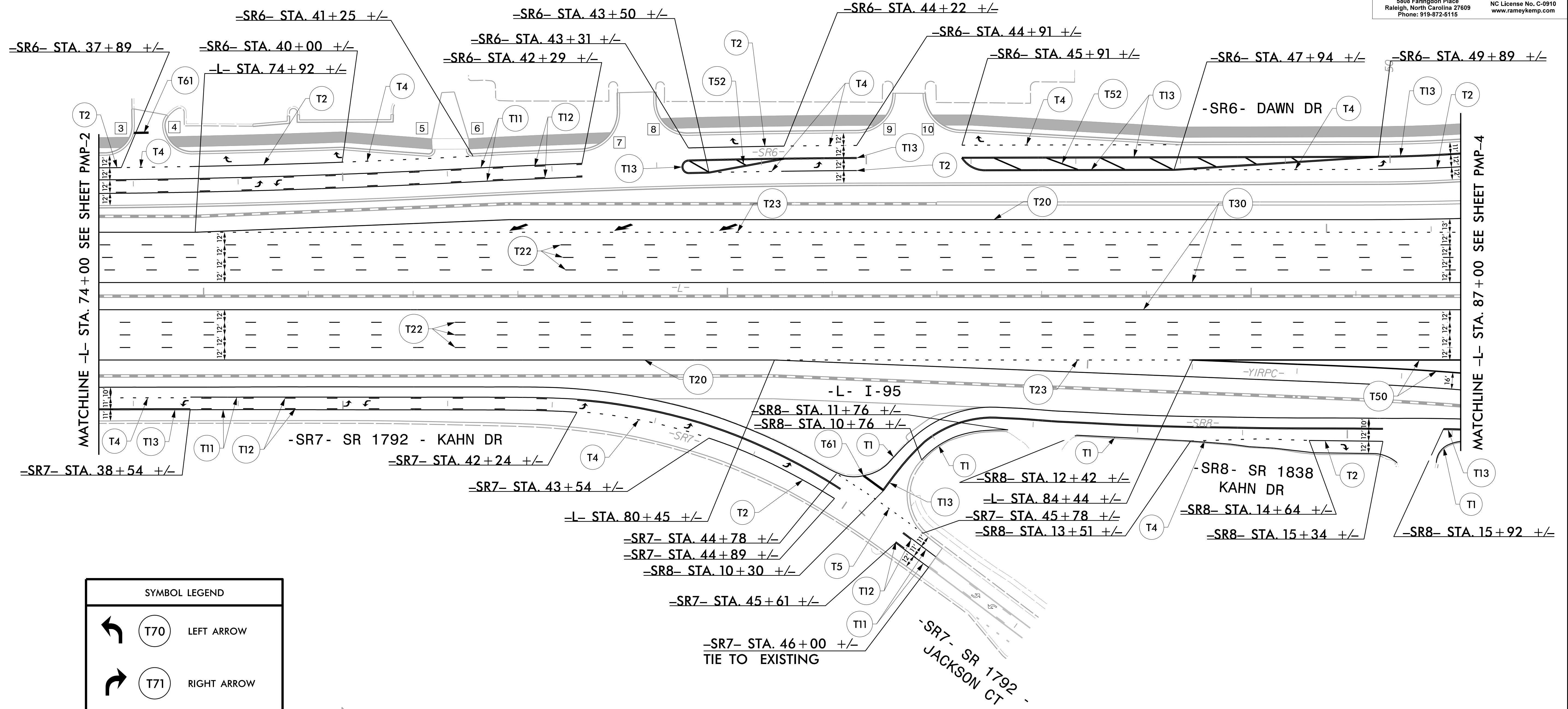

SYMBOL LEGEND		
	T70	LEFT ARROW
	T71	RIGHT ARROW
	T79	MERGE ARROW

**PAVEMENT MARKING DETAIL**

TIP NO.	SHEET NO.
I - 5987A	PMP - 4
APPROVED: <i>William J. Hamilton</i>	
DATE: 5/10/2022	
SEAL	
DOCUMENT NOT CONSIDERED FINAL UNLESS ALL SIGNATURES COMPLETED	
RAMEY KEMP ASSOCIATES 5808 Faringdon Place Raleigh, North Carolina 27609 Phone: 919-872-5115 NC License No. C-0910 www.rameykemp.com	

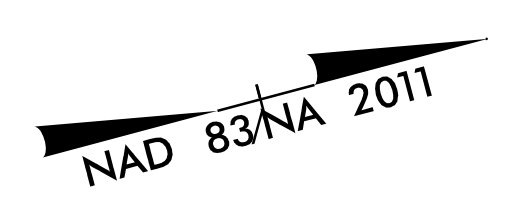

CURB RAMP LOCATIONS (CENTER OF RAMP AT FACE OF CURB)	
11	-SR6- STA. 51+86
12	-SR6- STA. 52+77
13	-SR6- STA. 53+80
14	-SR6- STA. 54+16

SYMBOL LEGEND	
	T70 LEFT ARROW
	T75 COMBO. LEFT/ RIGHT ARROW
	T79 MERGE ARROW

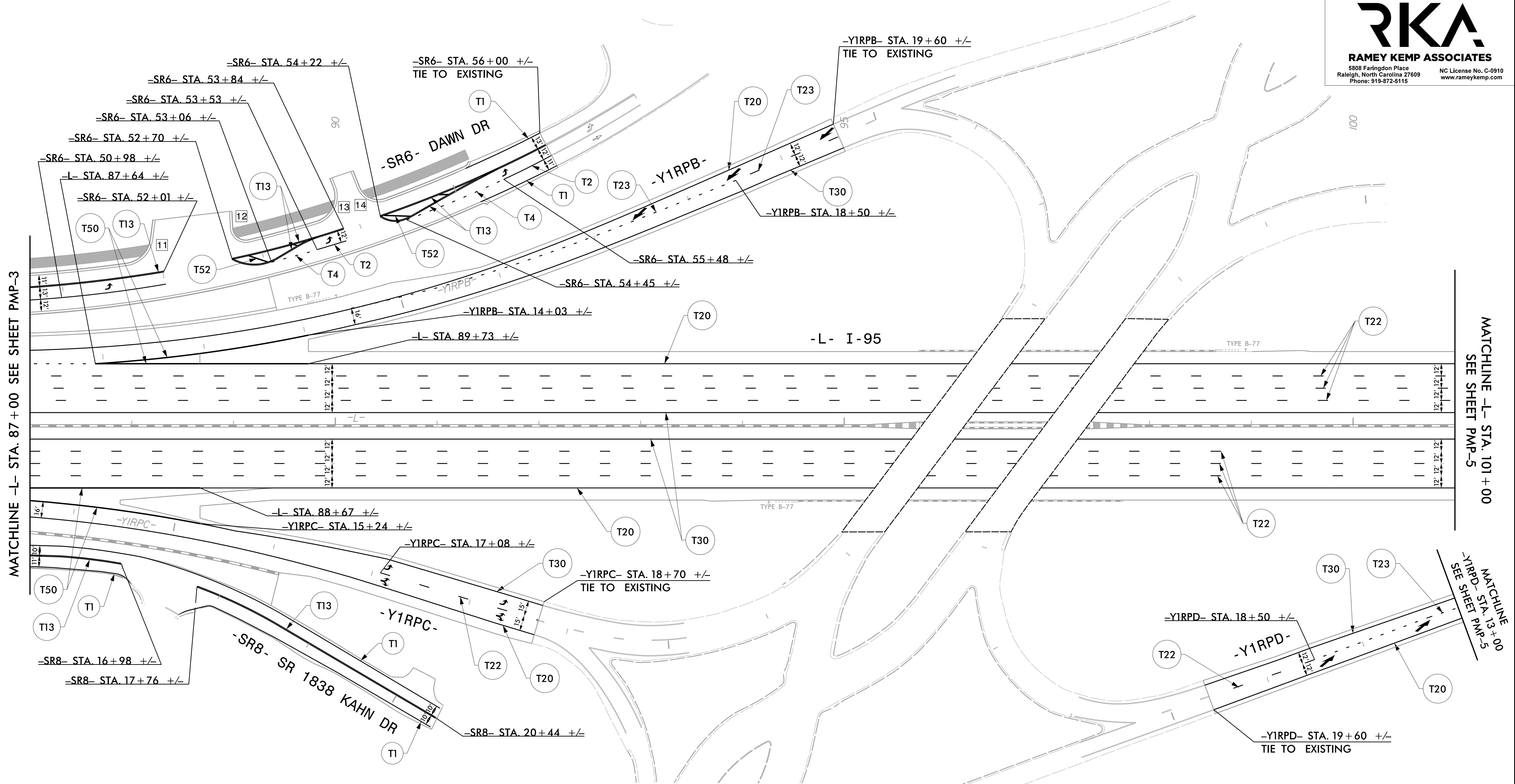

**PAVEMENT MARKING DETAIL**



TIP NO.	SHEET NO.
I - 5987A	PMP - 5
APPROVED: <i>William J. Hamilton</i> A0560070464844	
DATE: 5/10/2022	
SEAL	
DOCUMENT NOT CONSIDERED FINAL UNLESS ALL SIGNATURES COMPLETED	
<b>RAMEY KEMP ASSOCIATES</b> <small>5808 Faringdon Place Raleigh, North Carolina 27609 Phone: 919-872-5115</small>	

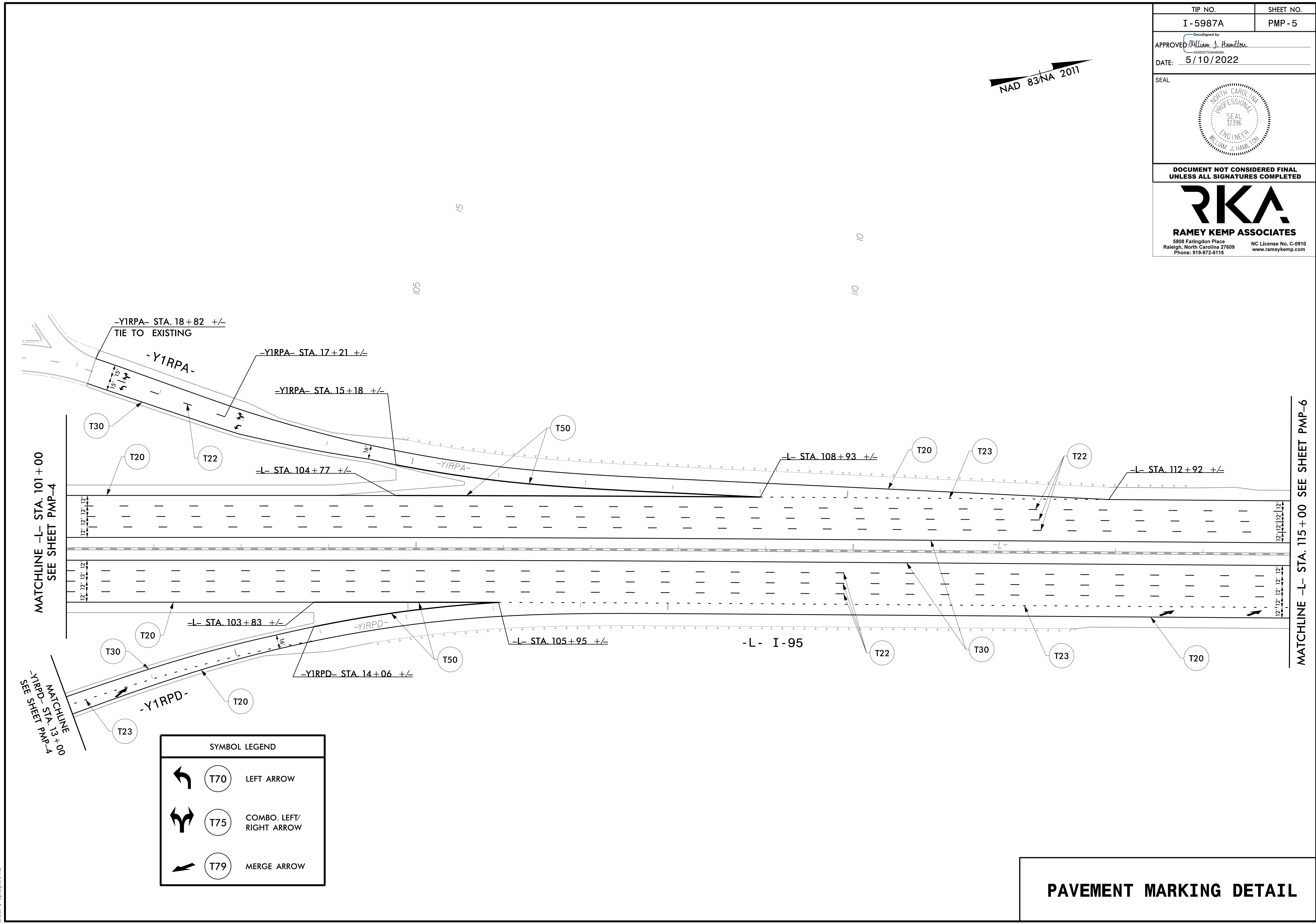
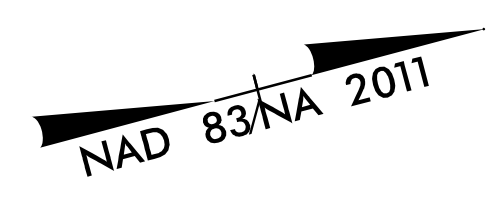

SYMBOL LEGEND		
	T70	LEFT ARROW
	T75	COMBO. LEFT/ RIGHT ARROW
	T79	MERGE ARROW

**PAVEMENT MARKING DETAIL**

5/10/2022  
I:\15687A\_PMP\_05.dgn  
User: tpope@rka

TIP NO.	SHEET NO.
I - 5987A	PMP - 6
APPROVED <i>William J. Hamilton</i> AUGUST 10 2022 10:48:54 AM	
DATE: 5/10/2022	
SEAL	
DOCUMENT NOT CONSIDERED FINAL UNLESS ALL SIGNATURES COMPLETED	
<b>RAMEY KEMP ASSOCIATES</b> <small>5808 Faringdon Place Raleigh, North Carolina 27609 Phone: 919-872-5115</small> <small>NC License No. C-0910 www.rameykemp.com</small>	

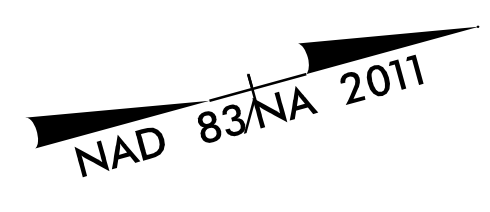

115

120

125

MATCHLINE -L- STA. 115 +00 SEE SHEET PMP-5

MATCHLINE -L- STA. 129 +00 SEE SHEET PMP-7

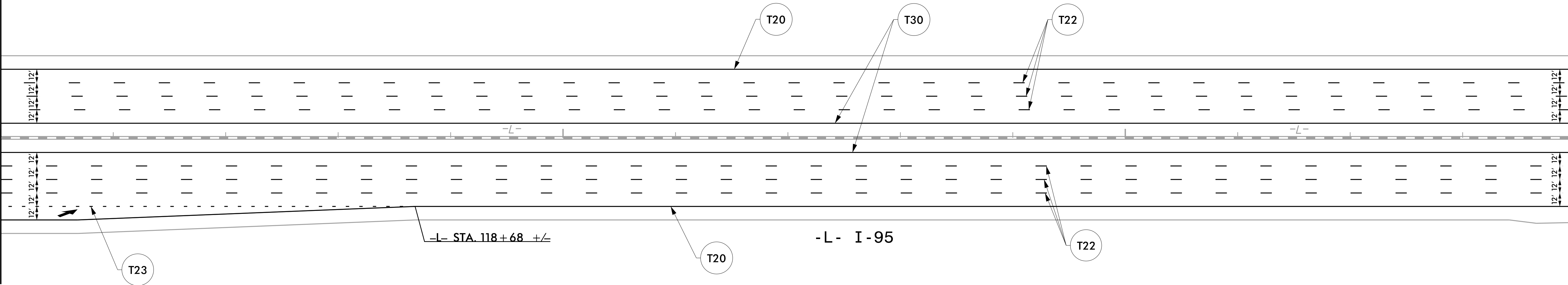

SYMBOL LEGEND	
	T79 MERGE ARROW

# PAVEMENT MARKING DETAIL

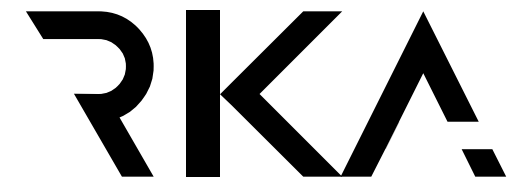
TIP NO.	SHEET NO.
I - 5987A	PMP - 7
APPROVED: <i>William J. Hamilton</i> <small>AG680704848484</small>	
DATE: 5/10/2022	
SEAL	
	
DOCUMENT NOT CONSIDERED FINAL UNLESS ALL SIGNATURES COMPLETED	
	
<b>RAMEY KEMP ASSOCIATES</b> <small>5808 Faringdon Place Raleigh, North Carolina 27609 Phone: 919-872-5115</small>	

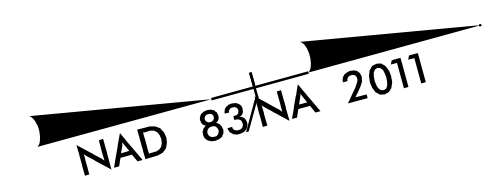

130  
130

135

140

MATCHLINE -L- STA. 129 +00 SEE SHEET PMP-6

MATCHLINE -L- STA. 143 +00 SEE SHEET PMP-8

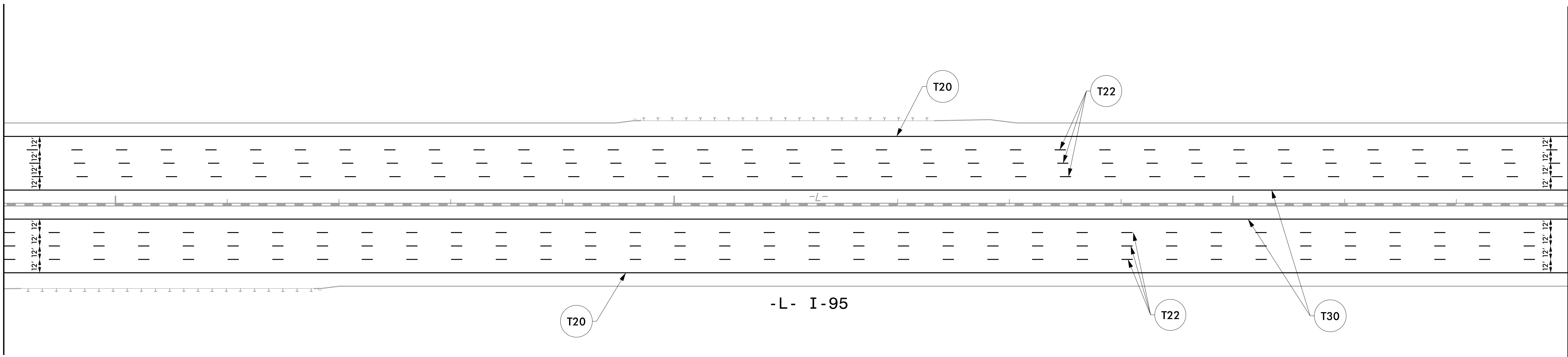

5/10/2022  
I:\15687A\_PMP\_07.dgn  
User: tpope@rka

# PAVEMENT MARKING DETAIL

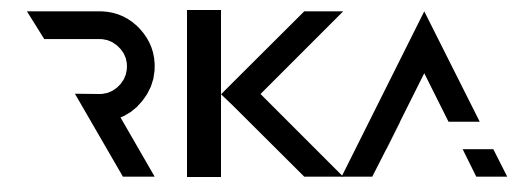

TIP NO.	SHEET NO.
I - 5987A	PMP - 8
APPROVED: <i>William J. Hamilton</i> AS0607046484	
DATE: 5/10/2022	
SEAL	
	
DOCUMENT NOT CONSIDERED FINAL UNLESS ALL SIGNATURES COMPLETED	
	
<b>RAMEY KEMP ASSOCIATES</b> <small>5808 Faringdon Place Raleigh, North Carolina 27609 Phone: 919-872-5115</small>	

NAD 83/NA 2011

145

150

155

MATCHLINE -L- STA. 143 +00 SEE SHEET PMP-7

MATCHLINE -L- STA. 157 +00 SEE SHEET PMP-9

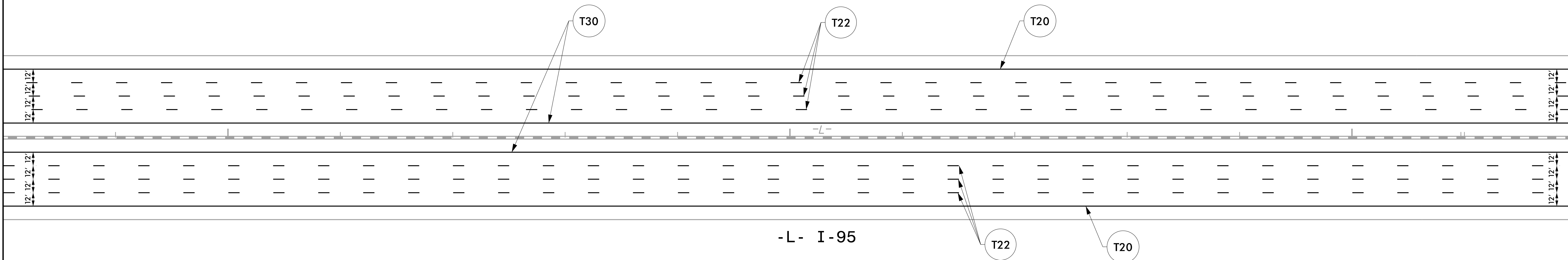

-L- I-95

5/10/2022  
I:\15987A\_PMP\_08.dgn  
User: tpope@rka

# PAVEMENT MARKING DETAIL

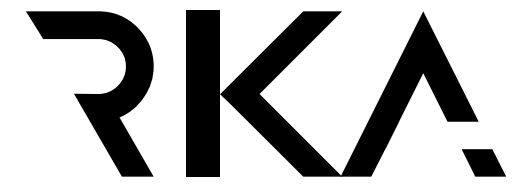
TIP NO.	SHEET NO.
I - 5987A	PMP - 9
APPROVED <i>William J. Hamilton</i> AUG0070468484	
DATE: 5/10/2022	
SEAL	
	
DOCUMENT NOT CONSIDERED FINAL UNLESS ALL SIGNATURES COMPLETED	
	
<b>RAMEY KEMP ASSOCIATES</b> <small>5808 Faringdon Place Raleigh, North Carolina 27609 Phone: 919-872-5115</small>	

NAD 83/NA 2011

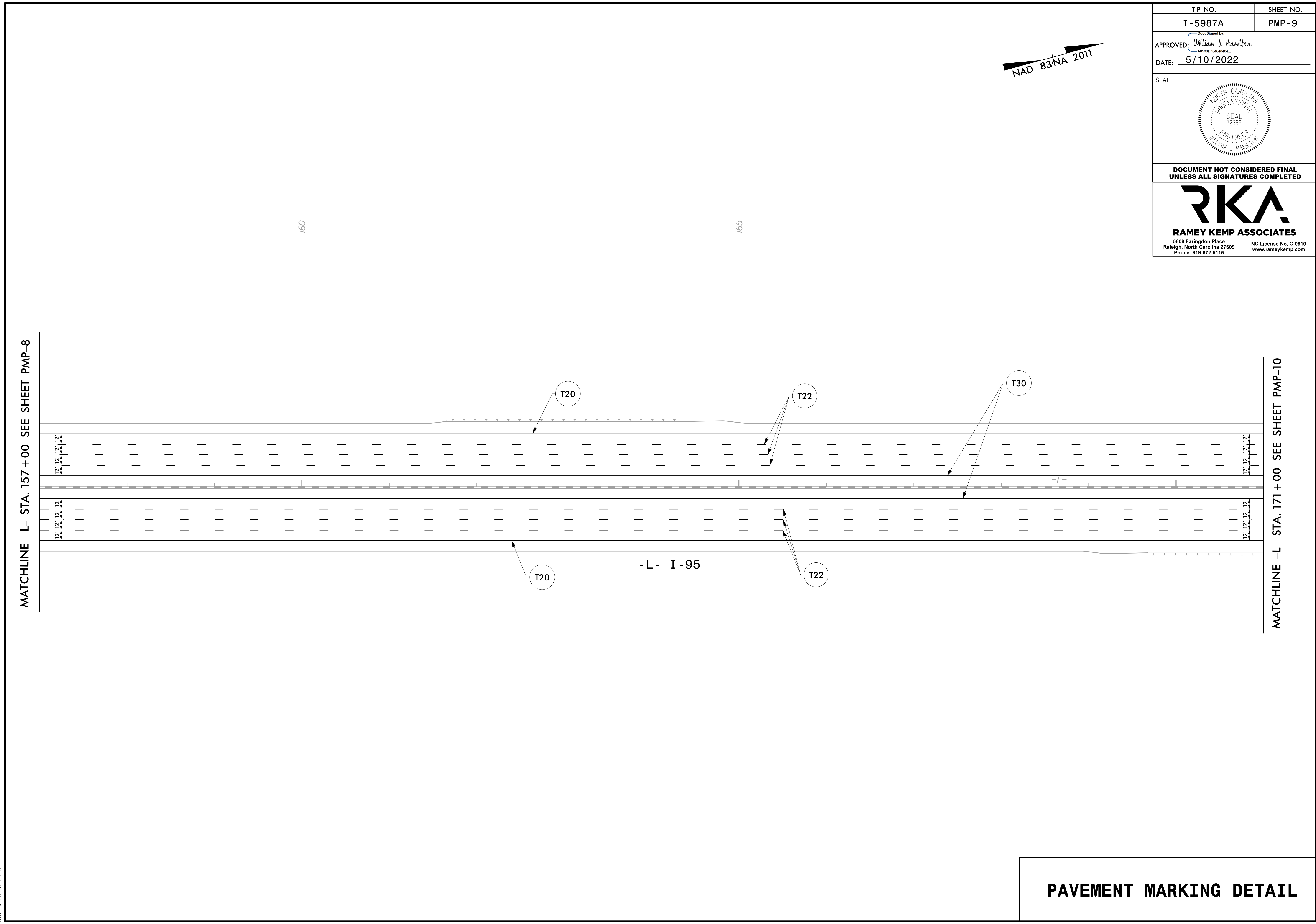

**PAVEMENT MARKING DETAIL**

5/10/2022  
I:\15987A\_PMP\_07.dgn  
User: tpope/lka

NAD 83/NA 2011

TIP NO.	SHEET NO.
I - 5987A	PMP - 10
APPROVED: <i>William J. Hamilton</i>	
DATE: 5/10/2022	
SEAL	
DOCUMENT NOT CONSIDERED FINAL UNLESS ALL SIGNATURES COMPLETED	
<b>RAMEY KEMP ASSOCIATES</b> <small>5808 Faringdon Place Raleigh, North Carolina 27609 Phone: 919-872-5115</small>	

MATCHLINE -L- STA. 171 + 00 SEE SHEET PMP-9

MATCHLINE -L- STA. 185 + 00 SEE SHEET PMP-11

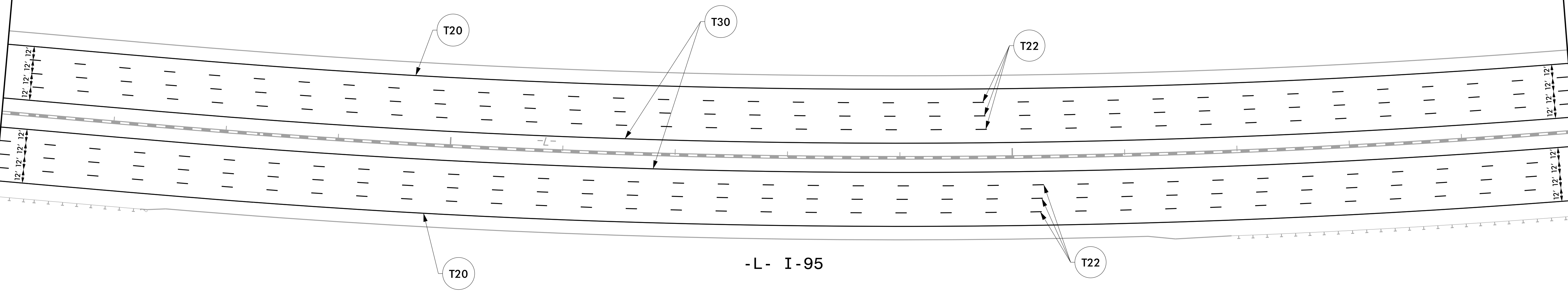

175

180

185

-L- I-95

PAVEMENT MARKING DETAIL

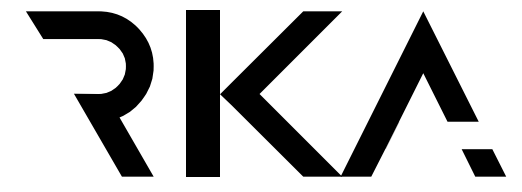

TIP NO.	SHEET NO.
I - 5987A	PMP - 11
APPROVED: <i>William J. Hamilton</i> <small>ACCREDITED PROFESSIONAL ENGINEER</small>	
DATE: 5/10/2022	
SEAL 	
DOCUMENT NOT CONSIDERED FINAL UNLESS ALL SIGNATURES COMPLETED	
 <b>RAMEY KEMP ASSOCIATES</b> <small>5808 Farington Place          Raleigh, North Carolina 27609          Phone: 919-872-5115</small>	

NAD 83/NA 2011

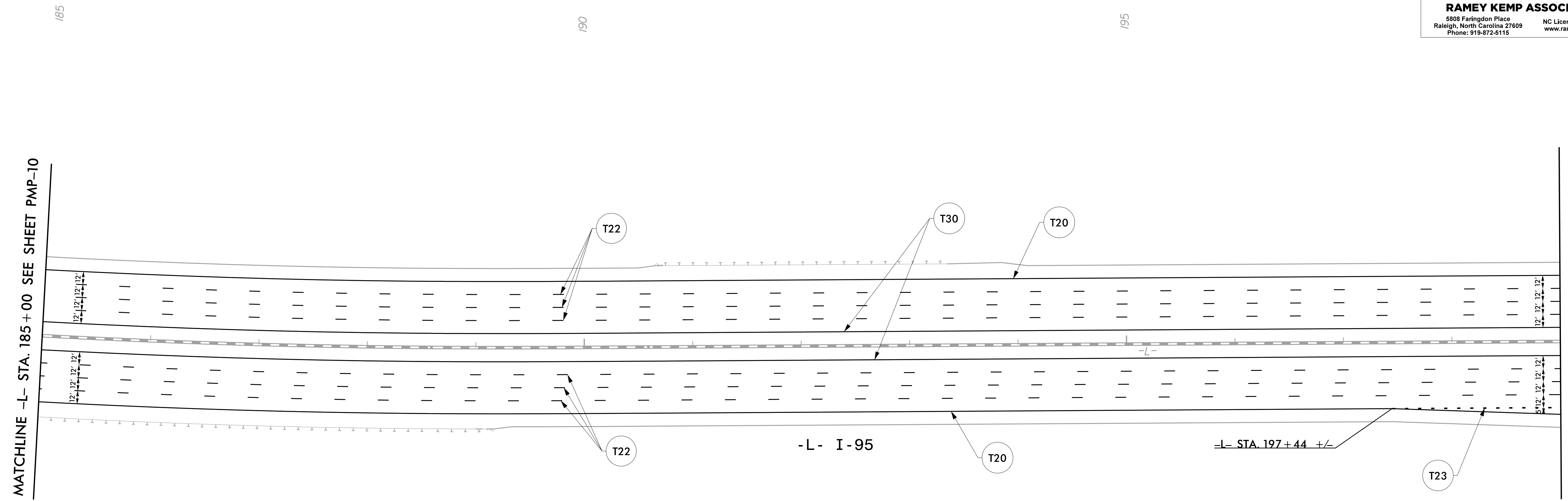

MATCHLINE -L- STA. 185 + 00 SEE SHEET PMP-10

MATCHLINE -L- STA. 199 + 00 SEE SHEET PMP-12

-L- I-95

-L- STA. 197 + 44 +/-

5/10/2022  
I:\15687A\_PMP-11.dgn  
User: tpoelko

# PAVEMENT MARKING DETAIL



TIP NO.	SHEET NO.
I - 5987A	PMP - 13
Approved by: <i>William J. Hamilton</i> <small>AJ5650704648484</small>	
DATE: 5/10/2022	
<b>DOCUMENT NOT CONSIDERED FINAL UNLESS ALL SIGNATURES COMPLETED</b>	
<b>RAMEY KEMP ASSOCIATES</b> <small>5808 Faringdon Place Raleigh, North Carolina 27609 Phone: 919-872-5115</small>	

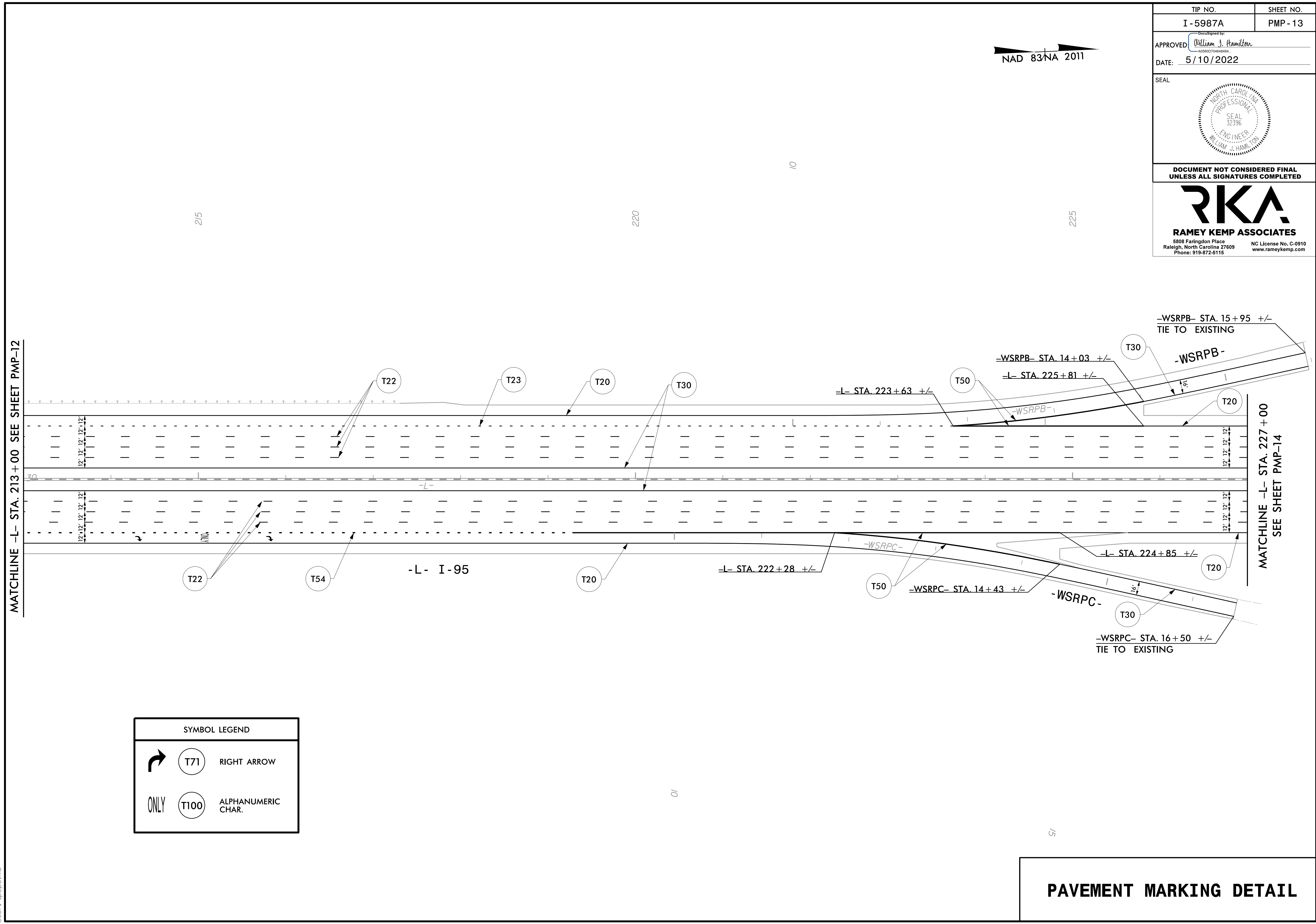
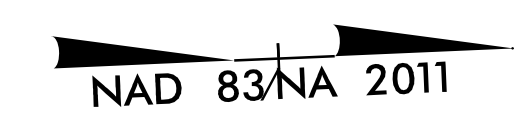

SYMBOL LEGEND	
	T71 RIGHT ARROW
	T100 ALPHANUMERIC CHAR.

**PAVEMENT MARKING DETAIL**

5/10/2022  
 I:\15687A\_PMP-13.dgn  
 User: tpope@rka



TIP NO.	SHEET NO.
I - 5987A	PMP - 14
APPROVED: <i>William J. Hamilton</i> AS260070484844	
DATE: 5/10/2022	
SEAL	
DOCUMENT NOT CONSIDERED FINAL UNLESS ALL SIGNATURES COMPLETED	
<b>RAMEY KEMP ASSOCIATES</b> <small>5808 Faringdon Place Raleigh, North Carolina 27609 Phone: 919-872-5115</small>	

NAD 83/NA 2011

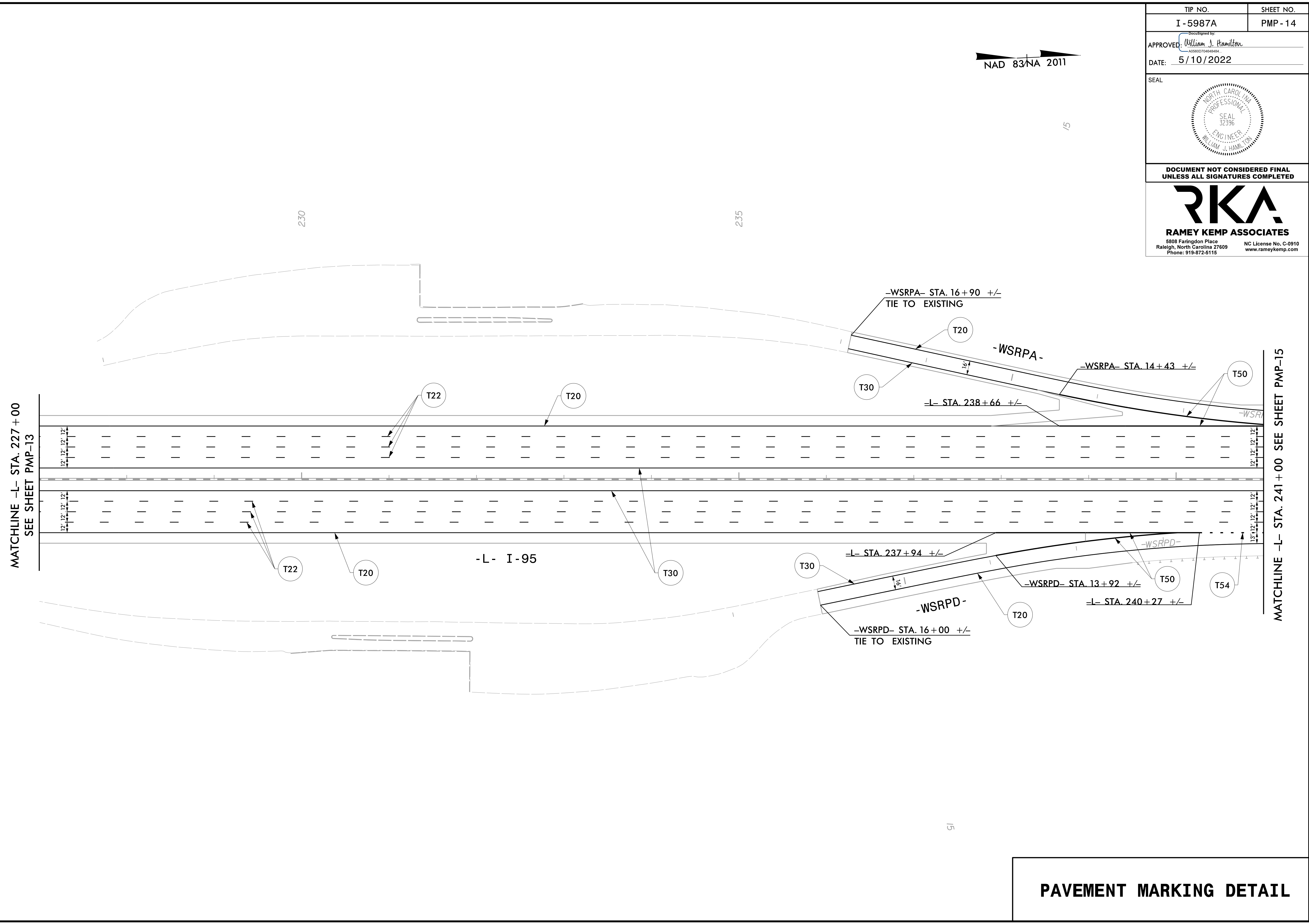

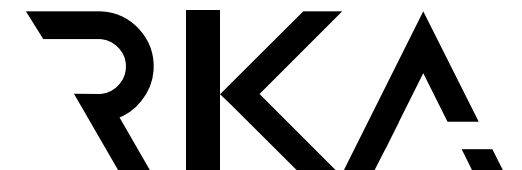

5/10/2022  
I:\15987A\_PMP-14.dgn  
User: tpope@rka

# PAVEMENT MARKING DETAIL

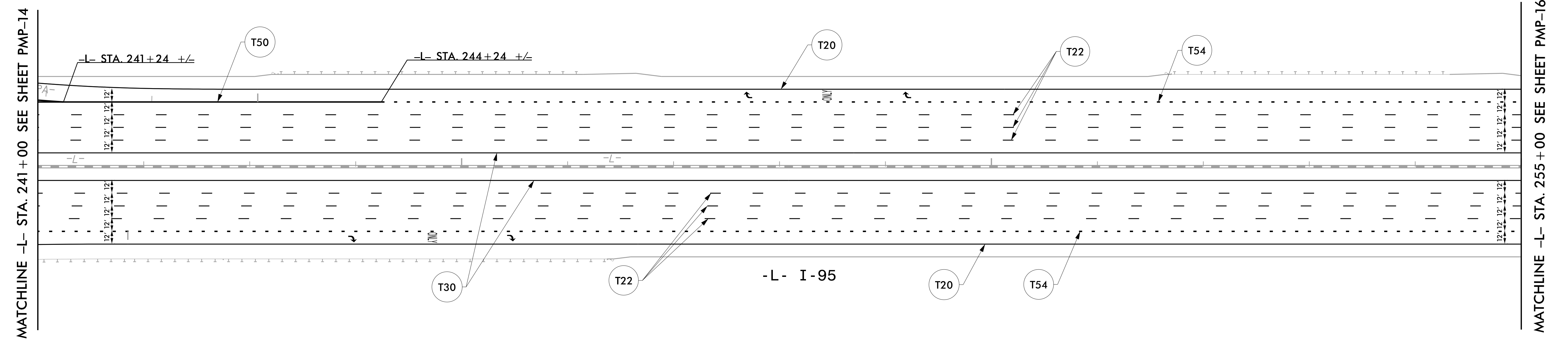
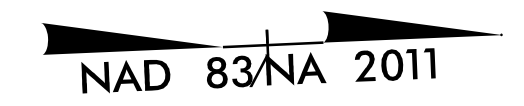
TIP NO.	SHEET NO.
I - 5987A	PMP - 15
<small>DocuSigned by:</small> APPROVED: <i>William J. Hamilton</i> <small>A1556070464844</small>	
DATE: 5/10/2022	
SEAL	
	
DOCUMENT NOT CONSIDERED FINAL UNLESS ALL SIGNATURES COMPLETED	
 <b>RAMEY KEMP ASSOCIATES</b> <small>5808 Faringdon Place Raleigh, North Carolina 27609 Phone: 919-872-5115</small>	

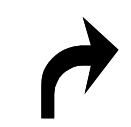



SYMBOL LEGEND	
	T71 RIGHT ARROW
	T100 ALPHANUMERIC CHAR.

**PAVEMENT MARKING DETAIL**

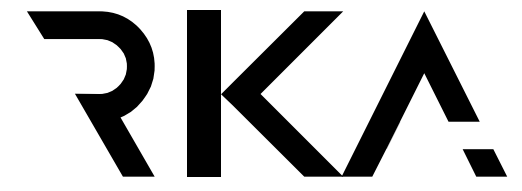
5/10/2022  
 I:\15687A\_PMP\_15.dgn  
 User: tpope\k

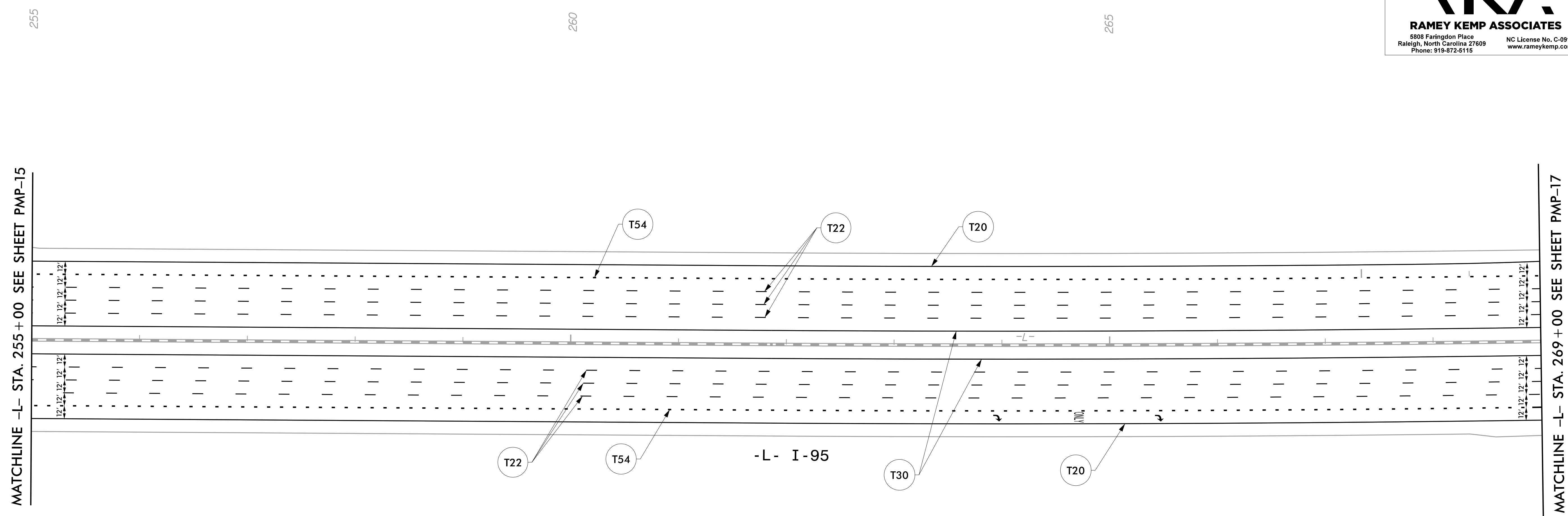
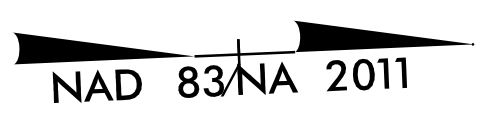
TIP NO. I - 5987A	SHEET NO. PMP - 16
APPROVED: <i>William J. Hamilton</i> A02600704848484	
DATE: 5/10/2022	
SEAL 	
DOCUMENT NOT CONSIDERED FINAL UNLESS ALL SIGNATURES COMPLETED	
 <b>RAMEY KEMP ASSOCIATES</b> <small>5808 Farington Place Raleigh, North Carolina 27609 Phone: 919-872-5115</small> <small>NC License No. C-0910 www.rameykemp.com</small>	

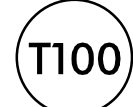

SYMBOL LEGEND	
	T71 RIGHT ARROW
	T100 ALPHANUMERIC CHAR.

**PAVEMENT MARKING DETAIL**

5/10/2022  
 I:\15987A\_PMP\_16.dgn  
 User: tpope@rka



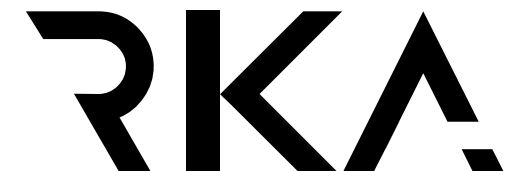

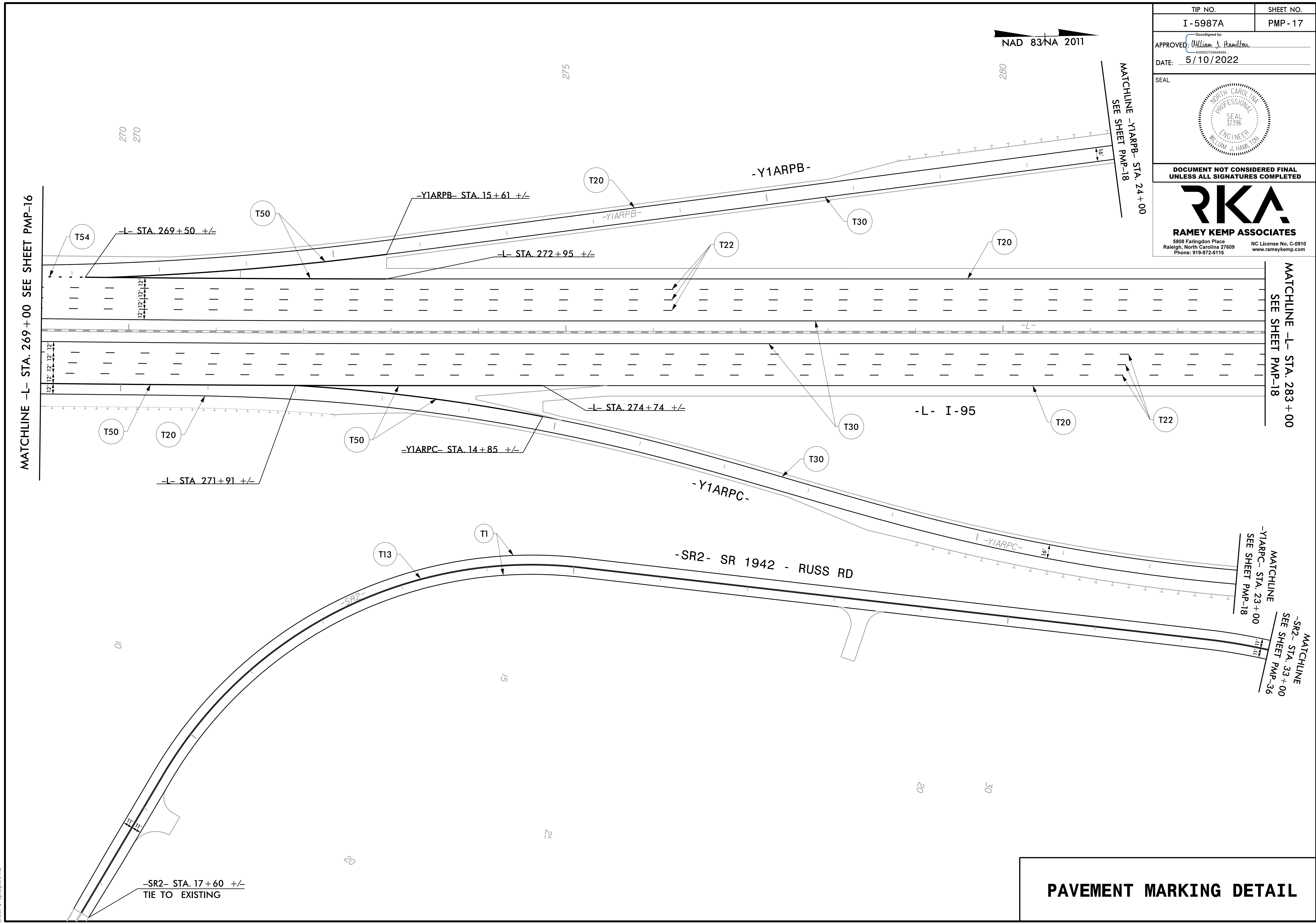
TIP NO.	SHEET NO.
I - 5987A	PMP - 17
APPROVED: <i>William J. Hamilton</i>	
DATE: 5/10/2022	
	
<p><b>DOCUMENT NOT CONSIDERED FINAL</b> UNLESS ALL SIGNATURES COMPLETED</p>  <p><b>RAMEY KEMP ASSOCIATES</b> 5808 Faringdon Place Raleigh, North Carolina 27609 Phone: 919-872-5115</p> <p>NC License No. C-0910 www.rameykemp.com</p>	

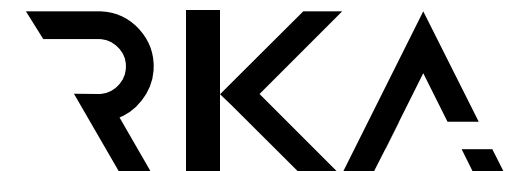

**PAVEMENT MARKING DETAIL**

5/10/2022  
I:\15987A\_PMP-17.dgn  
User: tpope@rka

TIP NO.	SHEET NO.
I - 5987A	PMP - 18
APPROVED: <i>William J. Hamilton</i>	
DATE: 5/10/2022	
SEAL	
	
DOCUMENT NOT CONSIDERED FINAL UNLESS ALL SIGNATURES COMPLETED	
	
<b>RAMEY KEMP ASSOCIATES</b> <small>5808 Faringdon Place Raleigh, North Carolina 27609 Phone: 919-872-5115</small>	

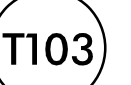
SYMBOL LEGEND	
	T80 WRONG-WAY RAMP ARROW
	T103 24" YIELD LINE TRIANGLE

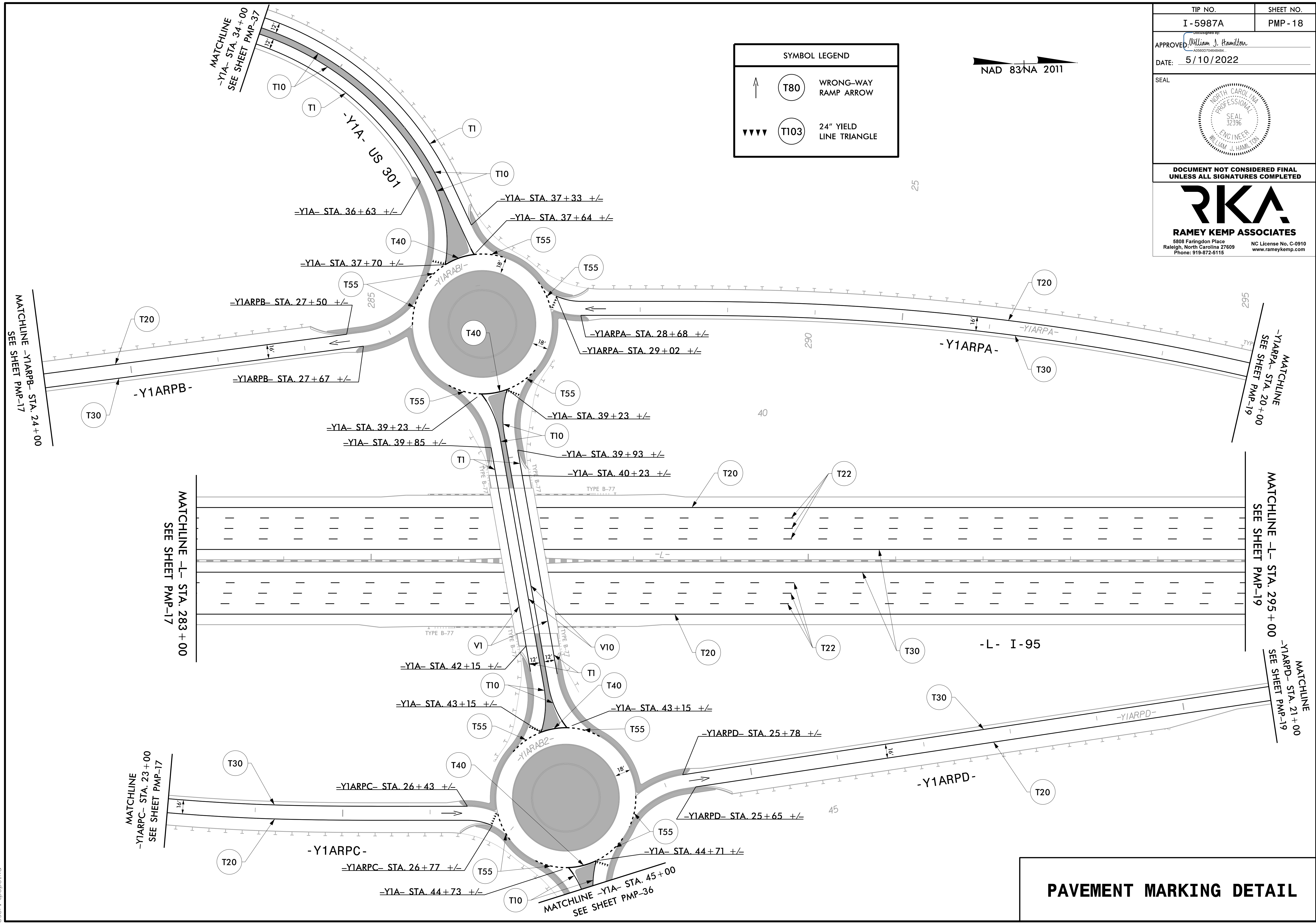

**PAVEMENT MARKING DETAIL**

5/10/2022  
 I:\15687A\_PMP\_18.dgn  
 User: tpope/lka

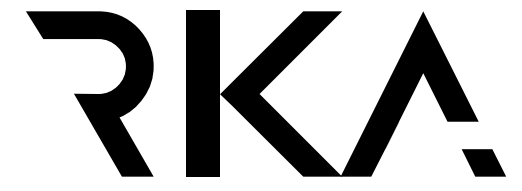

TIP NO.	SHEET NO.
I - 5987A	PMP - 19
APPROVED: <i>William J. Hamilton</i> PROFESSIONAL ENGINEER NO. 32396	
DATE: 5/10/2022	
SEAL	
	
DOCUMENT NOT CONSIDERED FINAL UNLESS ALL SIGNATURES COMPLETED	
	
<b>RAMEY KEMP ASSOCIATES</b> 5808 Faringdon Place Raleigh, North Carolina 27609 Phone: 919-872-5115 NC License No. C-0910 www.rameykemp.com	

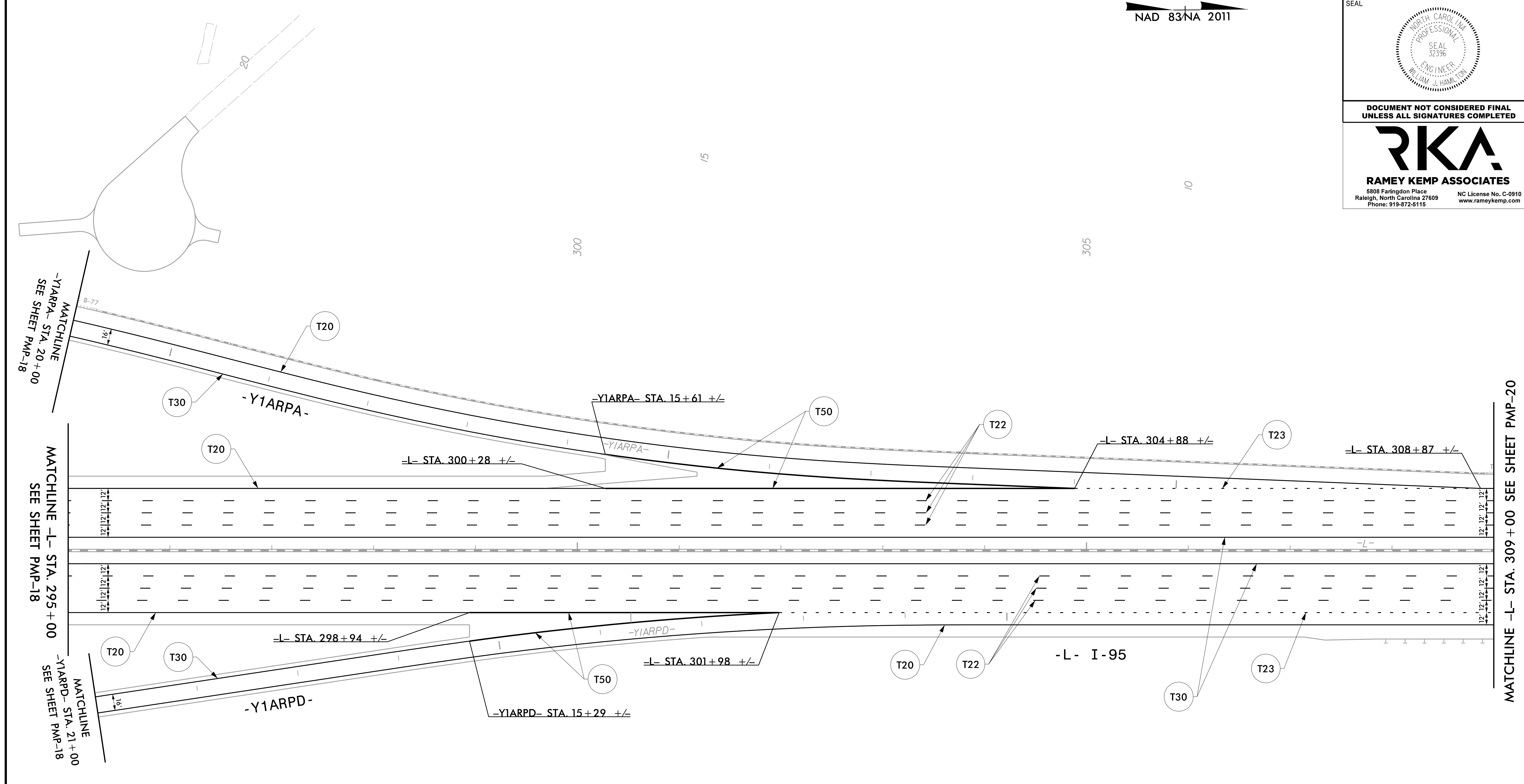
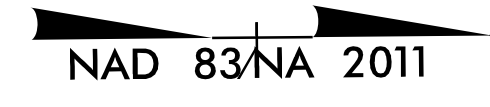

**PAVEMENT MARKING DETAIL**

5/10/2022  
I:\15687A\_PMP-19.dgn  
User: tpope@rka

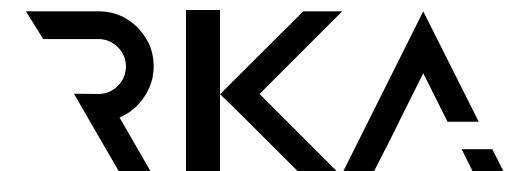
TIP NO.	SHEET NO.
I - 5987A	PMP - 20
APPROVED: <i>William J. Hamilton</i> <small>ASSETID: 04948484</small>	
DATE: 5/10/2022	
SEAL	
	
DOCUMENT NOT CONSIDERED FINAL UNLESS ALL SIGNATURES COMPLETED	
	
<b>RAMEY KEMP ASSOCIATES</b> <small>5808 Faringdon Place  Raleigh, North Carolina 27609  Phone: 919-872-5115</small>	

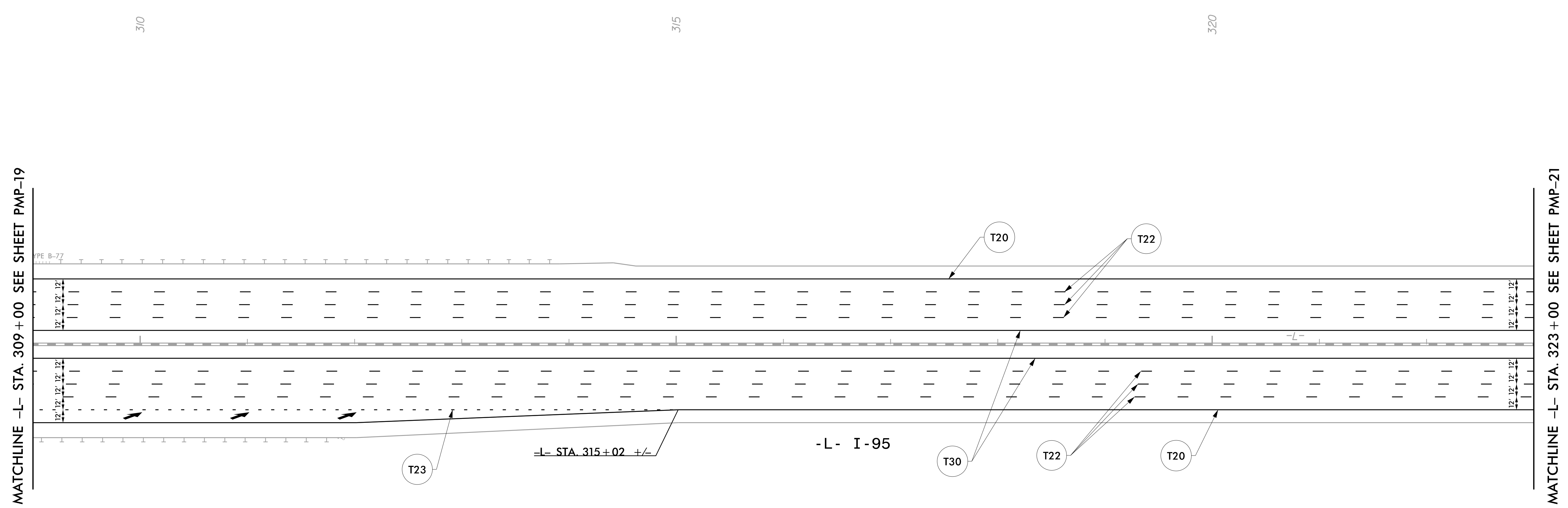
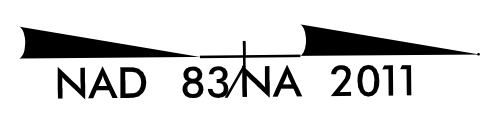

SYMBOL LEGEND	
	T79 MERGE ARROW

**PAVEMENT MARKING DETAIL**

5/10/2022  
I:\15987A\_PMP\_20.dgn  
User: tpope/lka



PMP-20

NAD 83/NA 2011

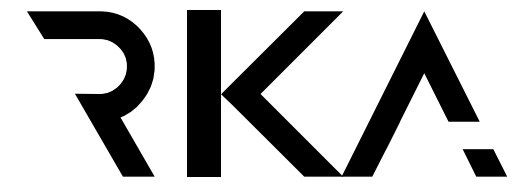
TIP NO.	SHEET NO.
I-5987A	PMP-21
APPROVED: <i>William J. Hamilton</i> AG-00070464844	
DATE: 5/10/2022	
SEAL	
	
DOCUMENT NOT CONSIDERED FINAL UNLESS ALL SIGNATURES COMPLETED	
	
<b>RAMEY KEMP ASSOCIATES</b> <small>5808 Faringdon Place Raleigh, North Carolina 27609 Phone: 919-872-5115</small>	

MATCHLINE -L- STA. 323 + 00 SEE SHEET PMP-20

MATCHLINE -L- STA. 337 + 00 SEE SHEET PMP-22

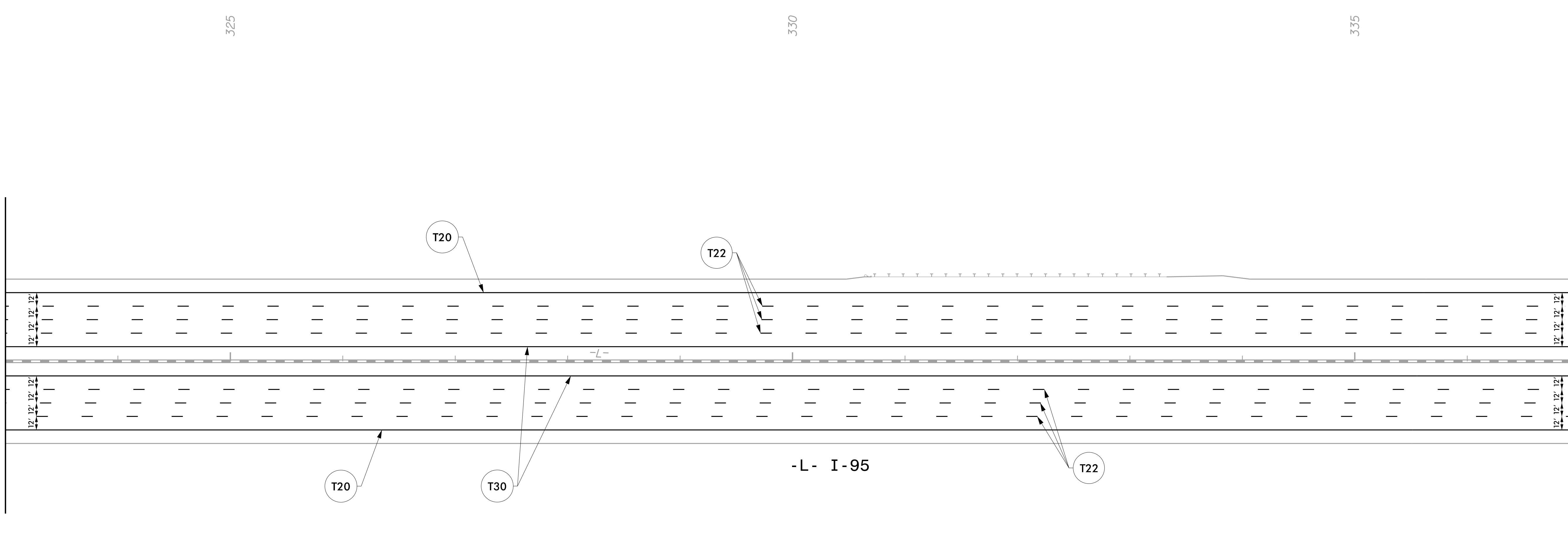

5/10/2022  
I:\15687A\_PMP-21.dgn  
User: tpope@kca

**PAVEMENT MARKING DETAIL**

NAD 83/NA 2011

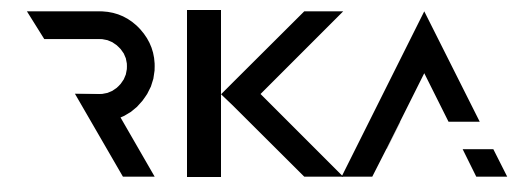
TIP NO.	SHEET NO.
I - 5987A	PMP - 22
APPROVED: <i>William J. Hamilton</i> <small>AS06070468484</small>	
DATE: 5/10/2022	
SEAL	
	
<p><b>DOCUMENT NOT CONSIDERED FINAL UNLESS ALL SIGNATURES COMPLETED</b></p>	
 <p><b>RAMEY KEMP ASSOCIATES</b> 5808 Faringdon Place Raleigh, North Carolina 27609 Phone: 919-872-5115</p> <p>NC License No. C-0910 www.rameykemp.com</p>	

MATCHLINE -L- STA. 337 + 00 SEE SHEET PMP-21

MATCHLINE -L- STA. 351 + 00 SEE SHEET PMP-23

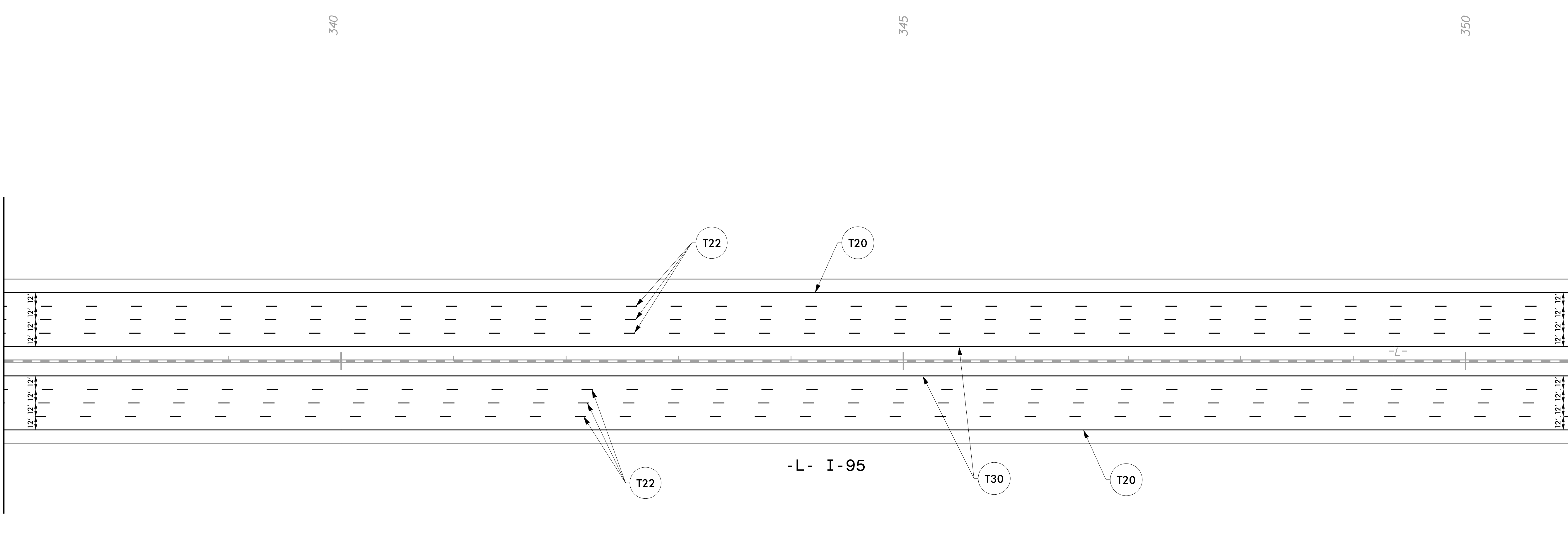

5/10/2022  
I:\15687A\_PMP-22.dgn  
User: tpope@rka

**PAVEMENT MARKING DETAIL**

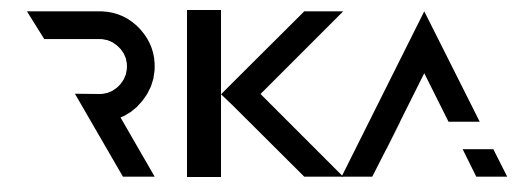
TIP NO.	SHEET NO.
I - 5987A	PMP - 23
APPROVED: <i>William J. Hamilton</i> <small>Professional Engineer License No. 27609</small>	
DATE: 5/10/2022	
SEAL	
	
<b>DOCUMENT NOT CONSIDERED FINAL UNLESS ALL SIGNATURES COMPLETED</b>	
	
<b>RAMEY KEMP ASSOCIATES</b> <small>5808 Faringdon Place Raleigh, North Carolina 27609 Phone: 919-872-5115</small>	

NAD 83/NA 2011

MATCHLINE -L- STA. 351 + 00 SEE SHEET PMP-22

MATCHLINE -L- STA. 365 + 00 SEE SHEET PMP-24

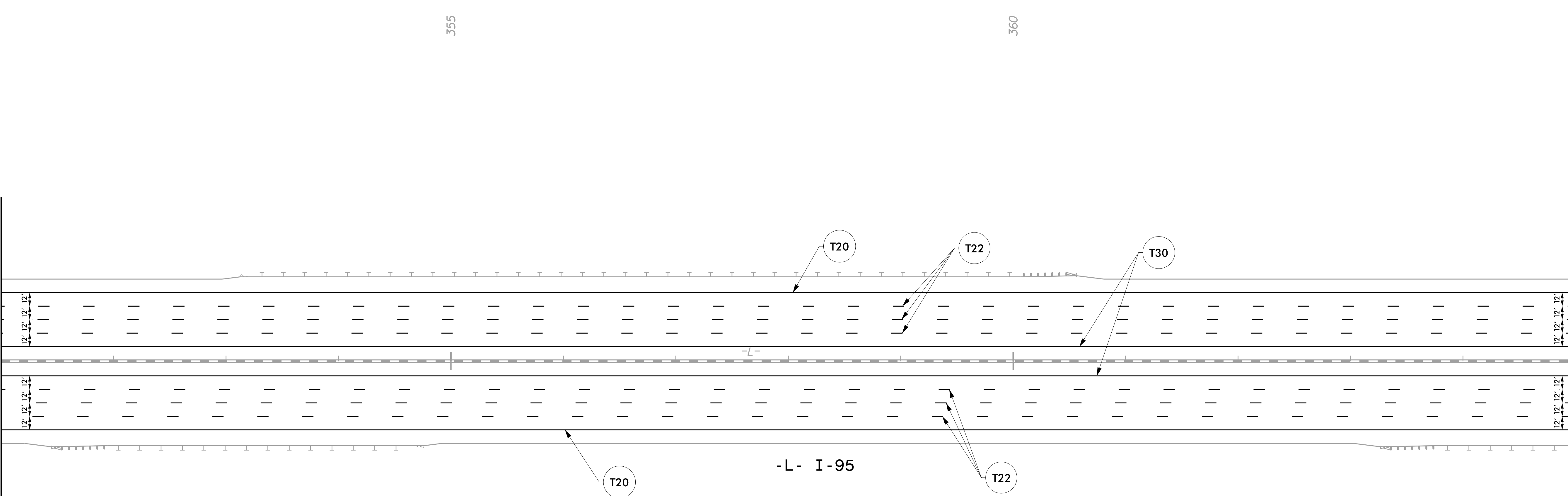

5/10/2022  
I:\15987A\_PMP-23.dgn  
User: tpope@rka

# PAVEMENT MARKING DETAIL

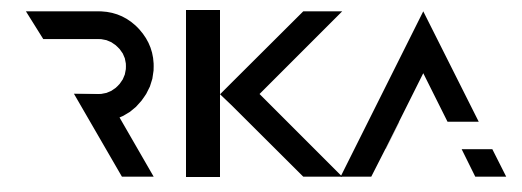
TIP NO.	SHEET NO.
I - 5987A	PMP - 24
APPROVED: <i>William J. Hamilton</i>	
DATE: 5/10/2022	
SEAL	
	
DOCUMENT NOT CONSIDERED FINAL UNLESS ALL SIGNATURES COMPLETED	
	
<b>RAMEY KEMP ASSOCIATES</b> <small>5808 Faringdon Place Raleigh, North Carolina 27609 Phone: 919-872-5115</small>	

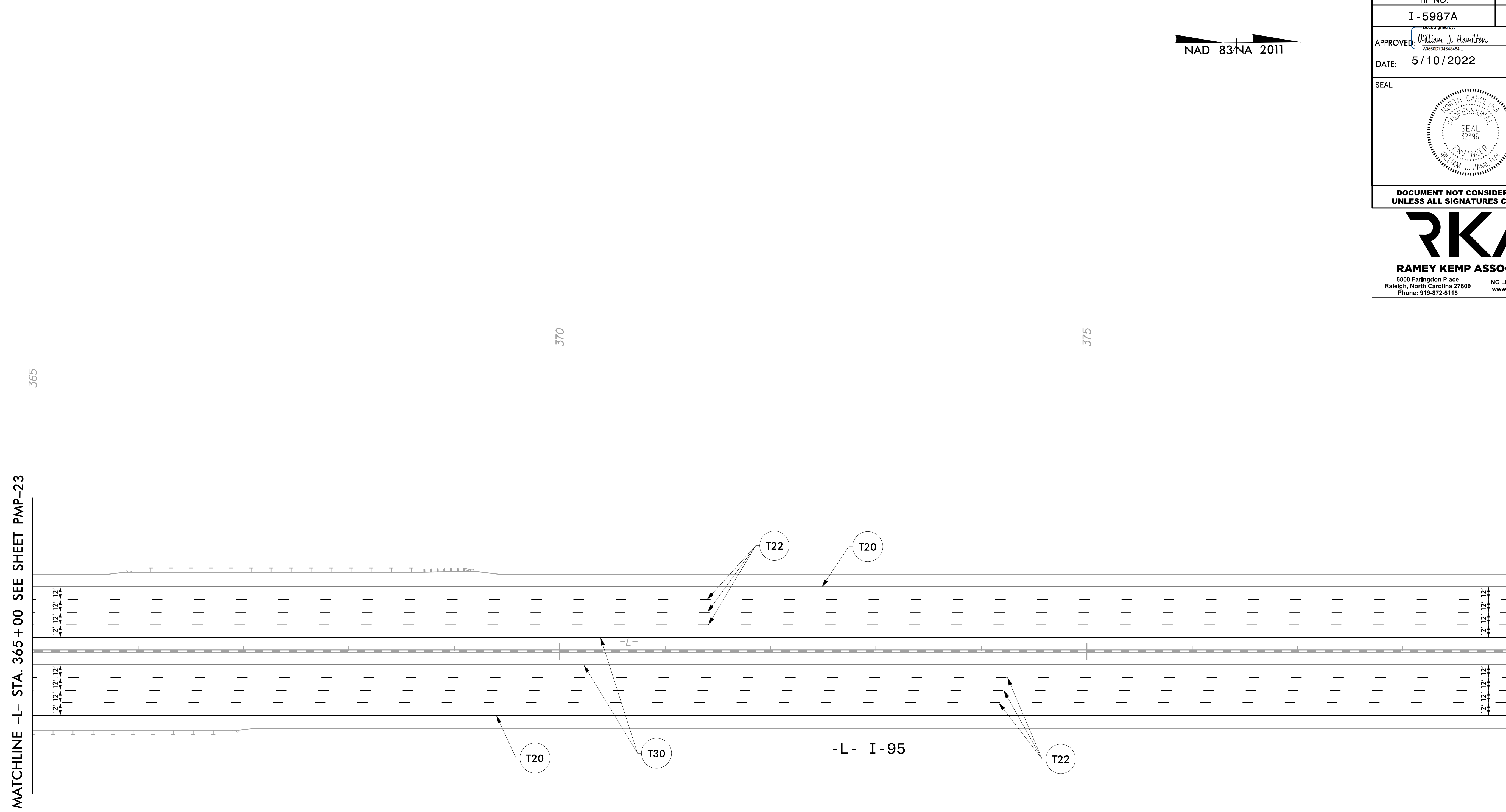
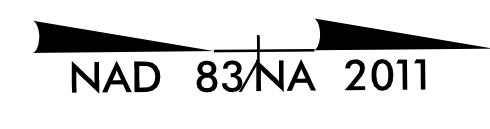

5/10/2022  
 I:\15987A\_PMP\_24.dgn  
 User: tpope@rka

**PAVEMENT MARKING DETAIL**

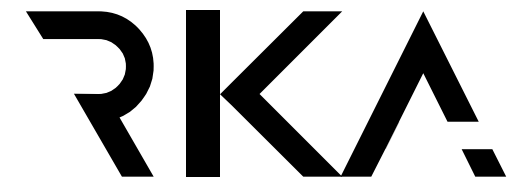

TIP NO.	SHEET NO.
I - 5987A	PMP - 25
APPROVED: <i>William J. Hamilton</i> <small>ACCREDITED 704848484</small>	
DATE: 5/10/2022	
SEAL 	
<b>DOCUMENT NOT CONSIDERED FINAL UNLESS ALL SIGNATURES COMPLETED</b>	
 <b>RAMEY KEMP ASSOCIATES</b> <small>5808 Faringdon Place Raleigh, North Carolina 27609 Phone: 919-872-5115</small>	

NAD 83/NA 2011

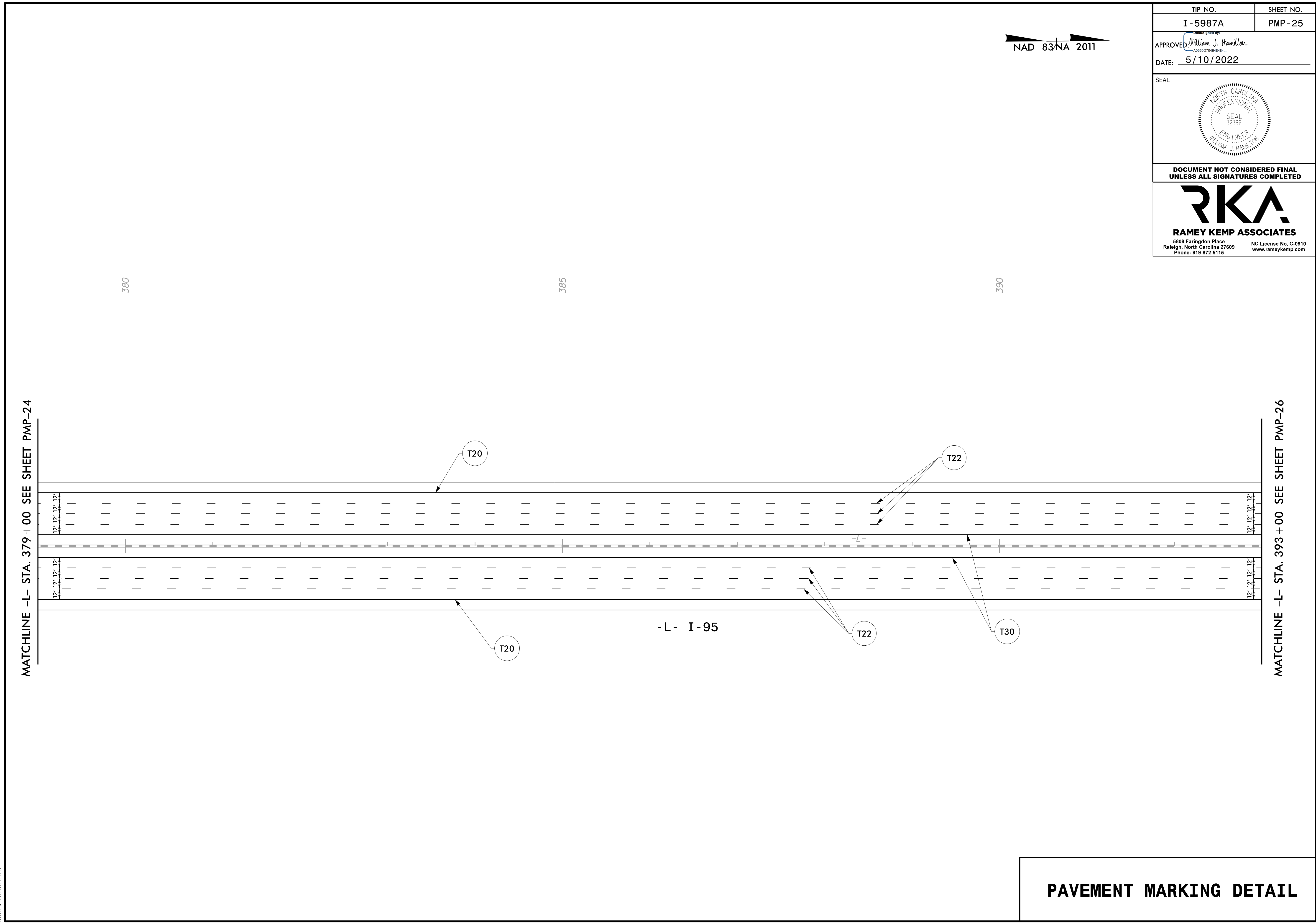

**PAVEMENT MARKING DETAIL**

5/10/2022  
I:\15687A\_PMP\_25.dgn  
User: tpope@rka

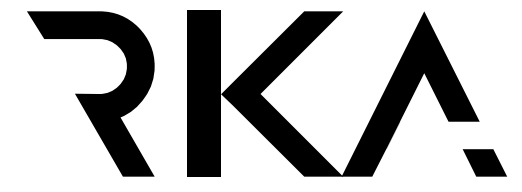
TIP NO.	SHEET NO.
I - 5987A	PMP - 26
APPROVED: <i>William J. Hamilton</i> <small>DocuSigned by:        A0568D704648484</small>	
DATE: 5/10/2022	
SEAL	
	
DOCUMENT NOT CONSIDERED FINAL UNLESS ALL SIGNATURES COMPLETED	
	
<b>RAMEY KEMP ASSOCIATES</b> <small>5808 Faringdon Place        Raleigh, North Carolina 27609        Phone: 919-872-5115</small>	

NAD 83/NA 2011

MATCHLINE -L- STA. 393 + 00 SEE SHEET PMP-25

MATCHLINE -L- STA. 407 + 00 SEE SHEET PMP-27

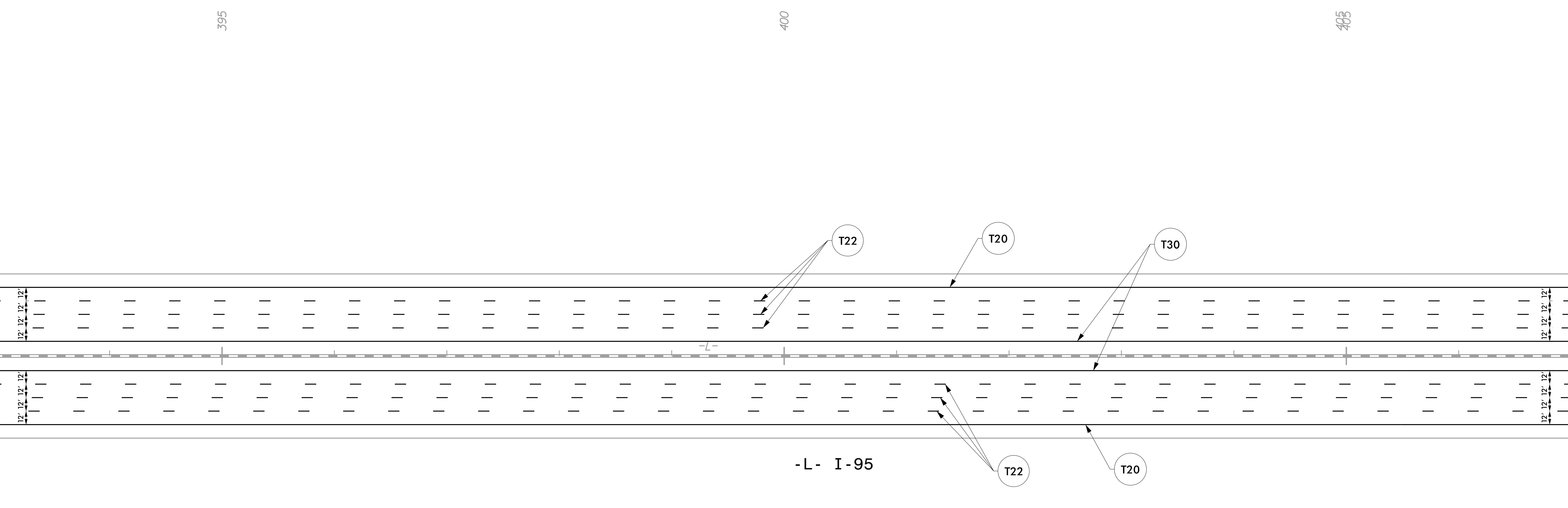

5/10/2022  
I:\15687A\_PMP-26.dgn  
User: tpope@rka

**PAVEMENT MARKING DETAIL**

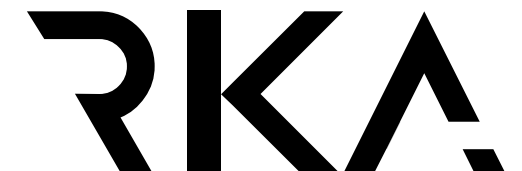
TIP NO.	SHEET NO.
I - 5987A	PMP - 27
DocuSigned by: APPROVED: <i>William J. Hamilton</i> <small>AD560070464844</small>	
DATE: 5/10/2022	
SEAL	
	
<b>DOCUMENT NOT CONSIDERED FINAL UNLESS ALL SIGNATURES COMPLETED</b>	
	
<b>RAMEY KEMP ASSOCIATES</b> <small>5808 Faringdon Place Raleigh, North Carolina 27609 Phone: 919-872-5115</small>	

NAD 83/NA 2011

MATCHLINE -L- STA. 407 + 00 SEE SHEET PMP-26

MATCHLINE -L- STA. 421 + 00 SEE SHEET PMP-28

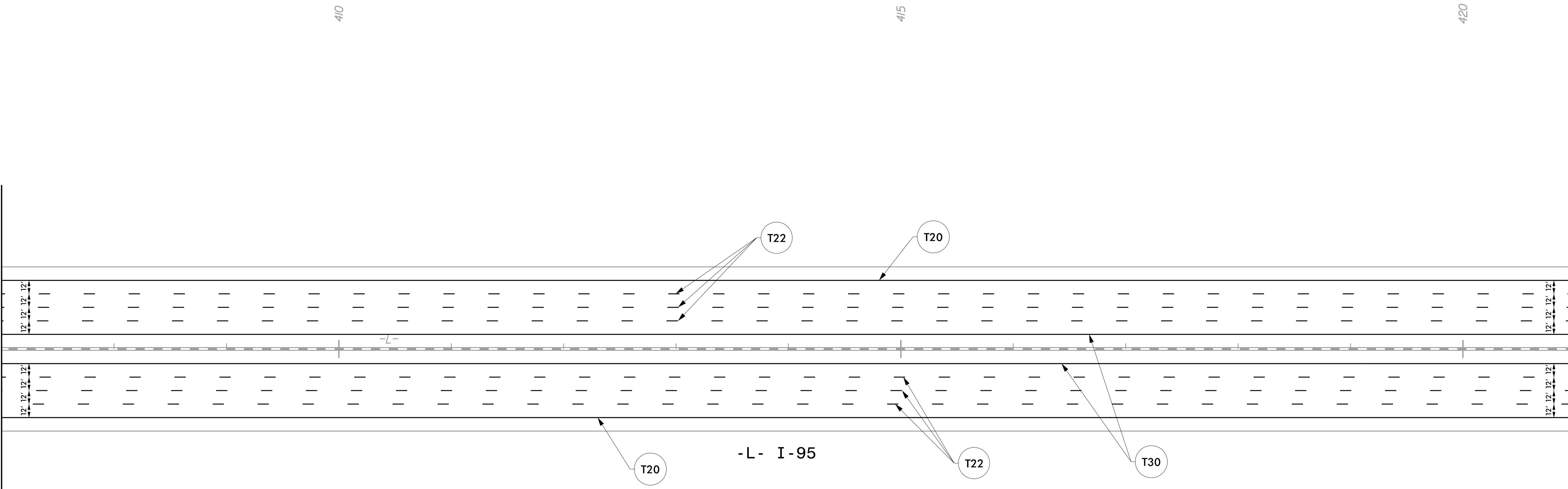

5/10/2022  
I:\15687A\_PMP-27.dgn  
User: tpcpe@rka

# PAVEMENT MARKING DETAIL

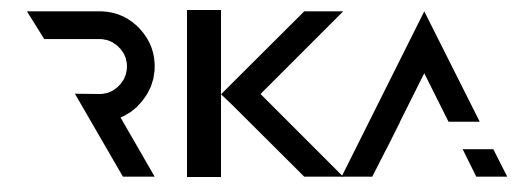
TIP NO.	SHEET NO.
I - 5987A	PMP - 28
APPROVED: <i>William J. Hamilton</i> Professional Engineer License No. 32396	
DATE: 5/10/2022	
SEAL	
	
DOCUMENT NOT CONSIDERED FINAL UNLESS ALL SIGNATURES COMPLETED	
	
<b>RAMEY KEMP ASSOCIATES</b> <small>5808 Faringdon Place Raleigh, North Carolina 27609 Phone: 919-872-5115</small>	

NAD 83/NA 2011

MATCHLINE -L- STA. 421 + 00 SEE SHEET PMP-27

MATCHLINE -L- STA. 435 + 00 SEE SHEET PMP-29

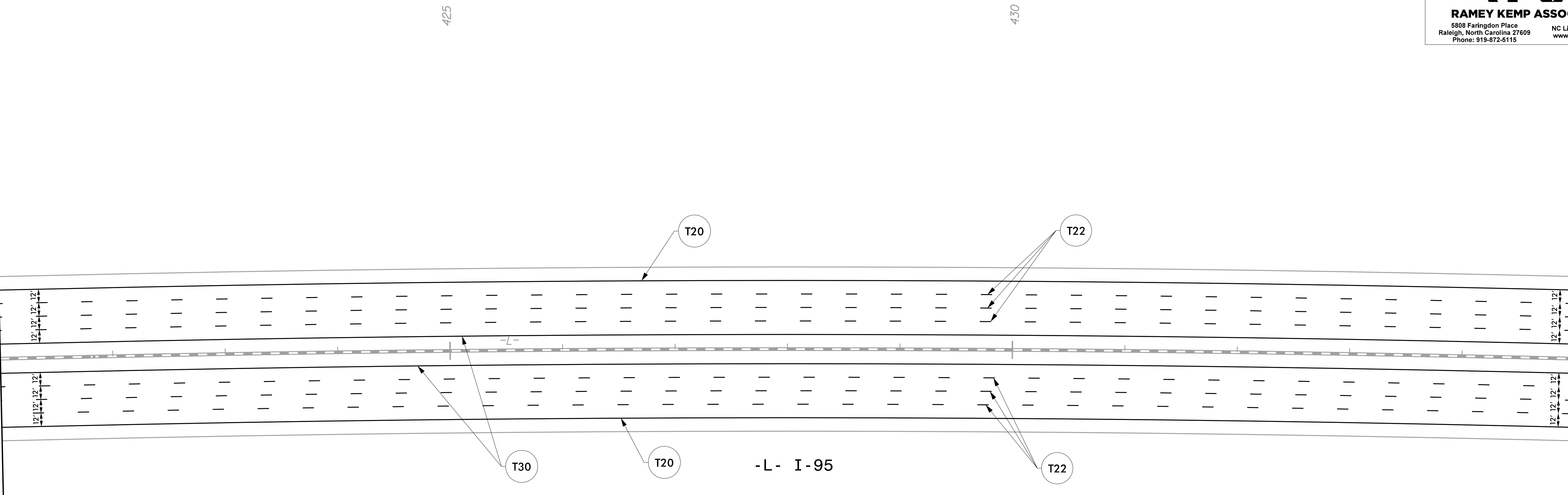

5/10/2022  
I:\15687A\_PMP-28.dgn  
User: tpope@rka

# PAVEMENT MARKING DETAIL

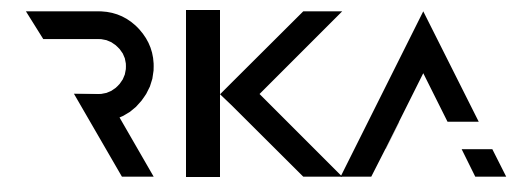

TIP NO.	SHEET NO.
I - 5987A	PMP - 29
APPROVED: <i>William J. Hamilton</i> AS2600704848484	
DATE: 5/10/2022	
SEAL	
	
DOCUMENT NOT CONSIDERED FINAL UNLESS ALL SIGNATURES COMPLETED	
	
<b>RAMEY KEMP ASSOCIATES</b> <small>5808 Faringdon Place Raleigh, North Carolina 27609 Phone: 919-872-5115</small>	

NAD 83/NA 2011

435

440

445

MATCHLINE -L- STA. 435 + 00 SEE SHEET PMP-28

MATCHLINE -L- STA. 449 + 00 SEE SHEET PMP-30

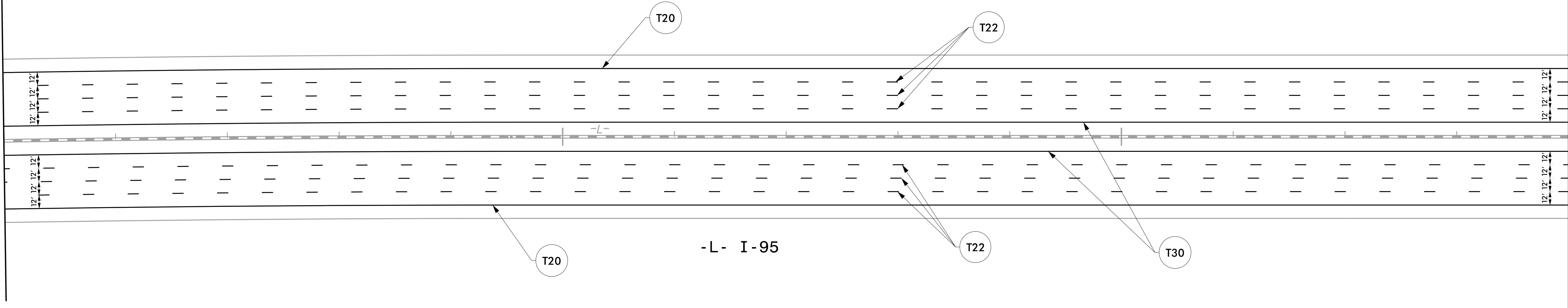

-L- I-95

5/10/2022  
I:\15687A\_PMP-29.dgn  
User: tpope@rka

**PAVEMENT MARKING DETAIL**

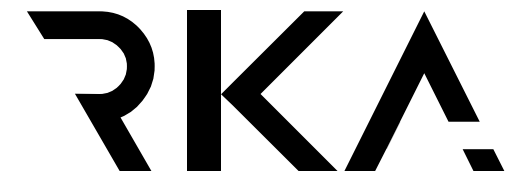
TIP NO.	SHEET NO.
I - 5987A	PMP - 30
APPROVED: <i>William J. Hamilton</i> A069070468464	
DATE: 5/10/2022	
SEAL	
	
DOCUMENT NOT CONSIDERED FINAL UNLESS ALL SIGNATURES COMPLETED	
	
<b>RAMEY KEMP ASSOCIATES</b> <small>5808 Farington Place Raleigh, North Carolina 27609 Phone: 919-872-5115</small>	

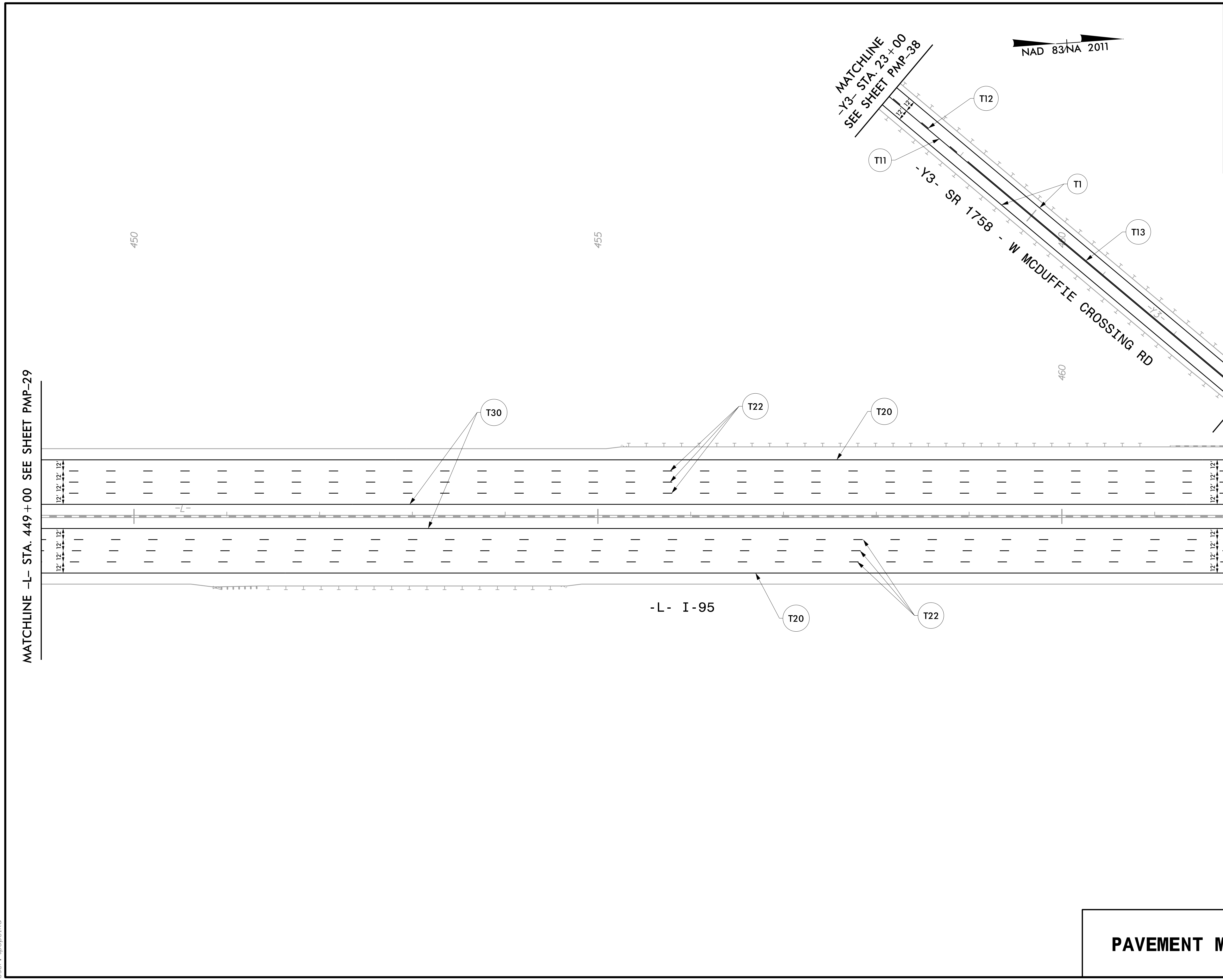

# PAVEMENT MARKING DETAIL

5/10/2022  
I:\15987A\_PMP\_30.dgn  
User: tpope@rka

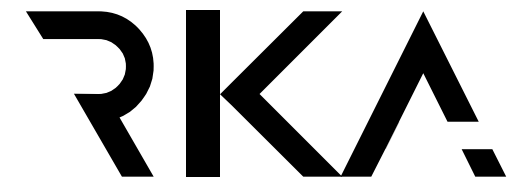
TIP NO.	SHEET NO.
I - 5987A	PMP - 31
APPROVED: <i>William J. Hamilton</i> <small>DESIGNED BY: William J. Hamilton  <small>ASSET ID: 04948484</small></small>	
DATE: 5/10/2022	
SEAL	
	
DOCUMENT NOT CONSIDERED FINAL UNLESS ALL SIGNATURES COMPLETED	
	
<b>RAMEY KEMP ASSOCIATES</b> <small>5808 Faringdon Place  Raleigh, North Carolina 27609  Phone: 919-872-5115</small> <small>NC License No. C-0910  www.rameykemp.com</small>	

NAD 83 NA 2011

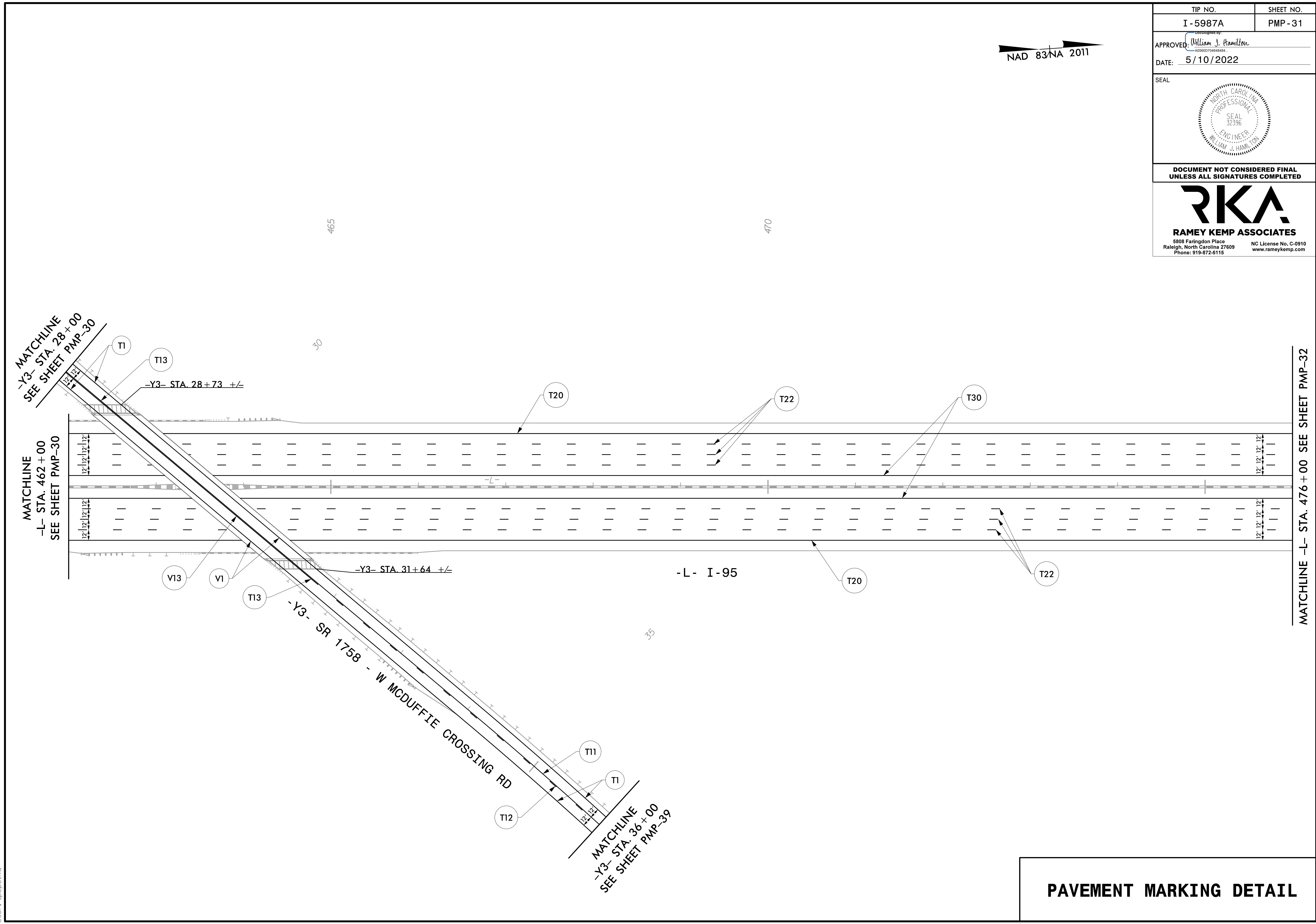

5/10/2022  
I:\15687A\_PMP\_31.dgn  
User: tpope@rka

# PAVEMENT MARKING DETAIL

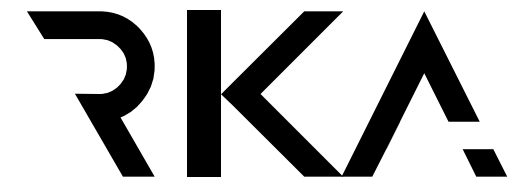
TIP NO.	SHEET NO.
I - 5987A	PMP - 32
APPROVED: <u>William J. Hamilton</u> <small>AS0001704040484</small>	
DATE: <u>5/10/2022</u>	
SEAL	
	
<b>DOCUMENT NOT CONSIDERED FINAL UNLESS ALL SIGNATURES COMPLETED</b>	
	
<b>RAMEY KEMP ASSOCIATES</b> <small>5808 Faringdon Place Raleigh, North Carolina 27609 Phone: 919-872-5115</small>	

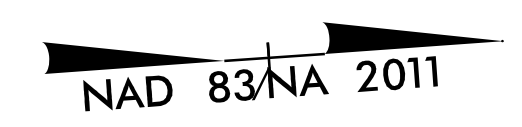

MATCHLINE -L- STA. 476 + 00 SEE SHEET PMP-31

MATCHLINE -L- STA. 476 + 00 SEE SHEET PMP-33

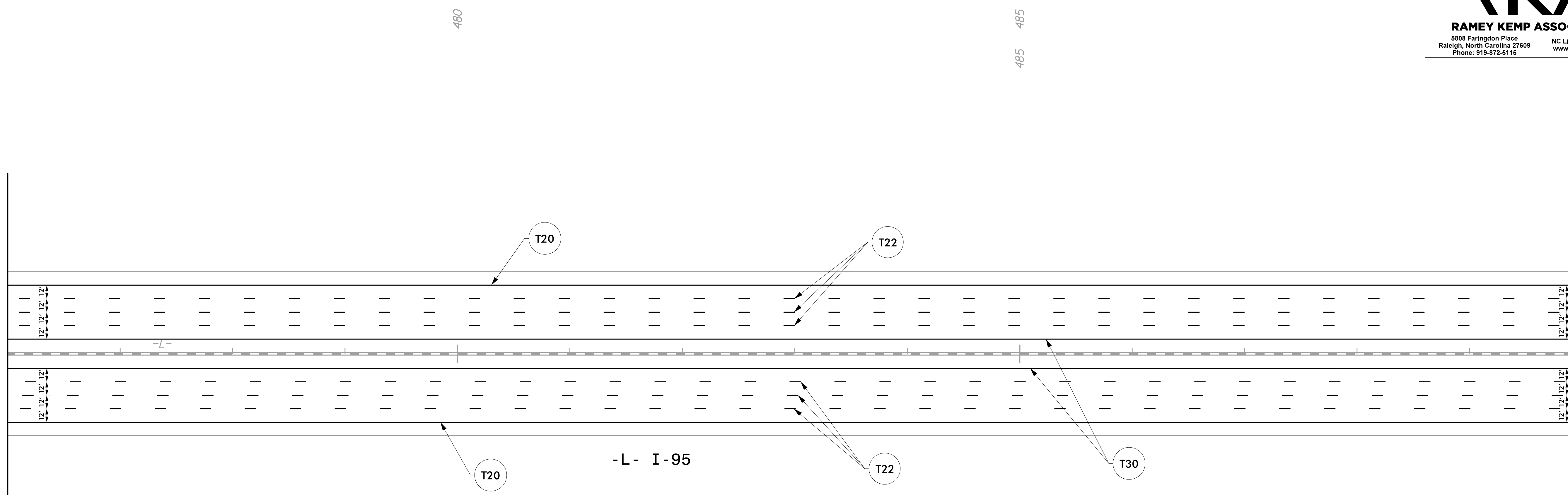

5/10/2022  
I:\15687A\_PMP\_32.dgn  
User: tpope\k

**PAVEMENT MARKING DETAIL**

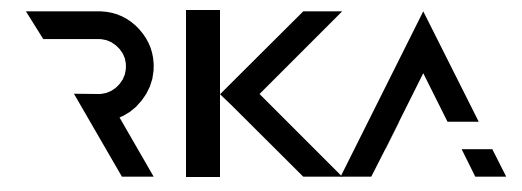

TIP NO. <b>I - 5987A</b>	SHEET NO. <b>PMP - 33</b>
APPROVED: <i>William J. Hamilton</i> <small>Date Signed by: 70590071648584</small>	
DATE: <b>5/10/2022</b>	
SEAL 	
<b>DOCUMENT NOT CONSIDERED FINAL UNLESS ALL SIGNATURES COMPLETED</b>	
 <b>RAMEY KEMP ASSOCIATES</b> <small>5808 Faringdon Place Raleigh, North Carolina 27609 Phone: 919-872-5115</small> <small>NC License No. C-0910 www.rameykemp.com</small>	

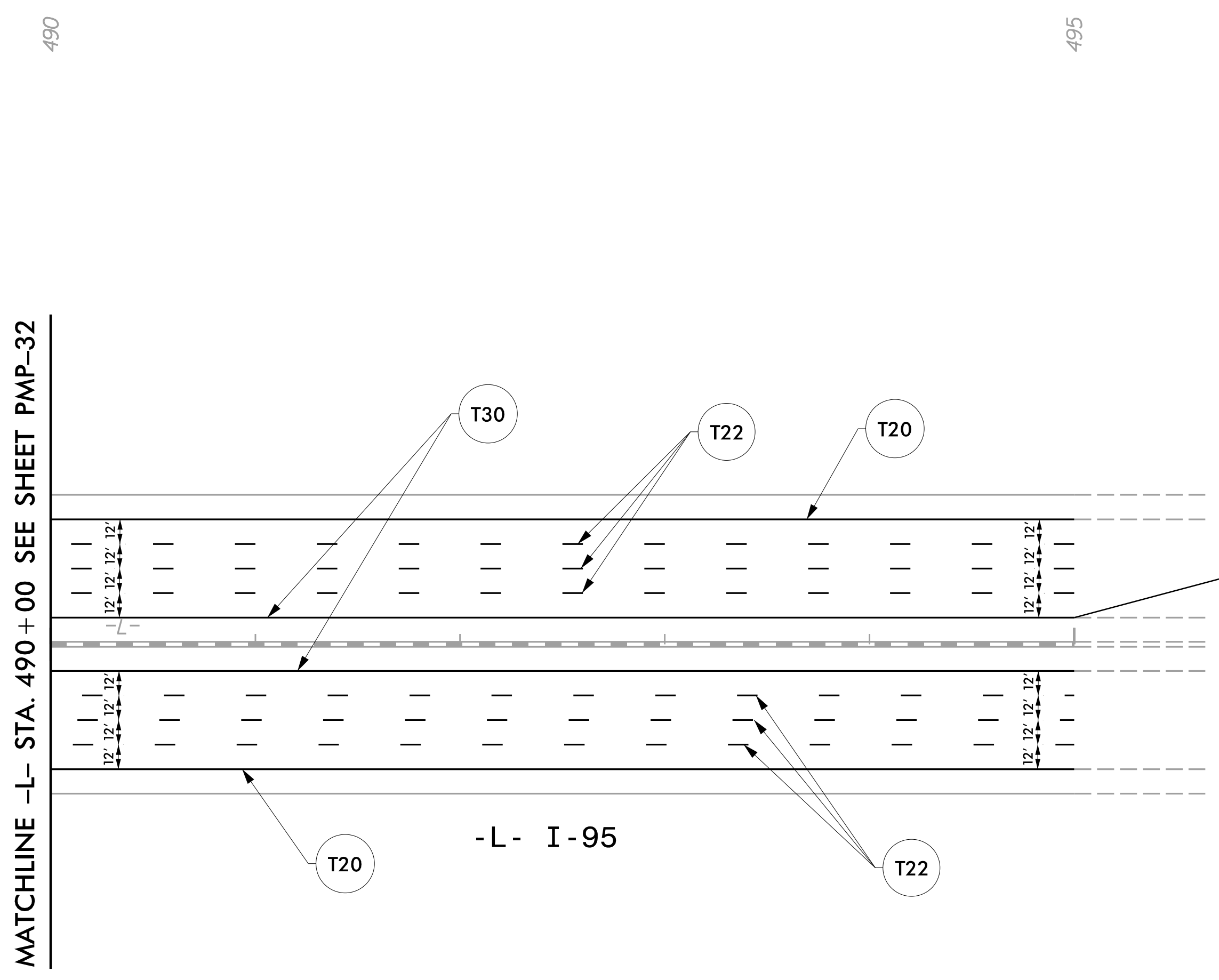

END TIP PROJECT I-5987A  
 -L- STA. 495 + 00 +/-  
 BEGIN TIP PROJECT I-5987B  
 -L- STA. 495 + 00 +/-

5/10/2022  
 I:\15987A\_PMP\_33.dgn  
 User: tpope@rka

**PAVEMENT MARKING DETAIL**

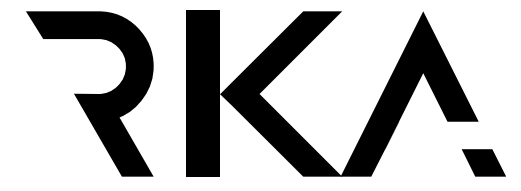
TIP NO.	SHEET NO.
I - 5987A	PMP - 34
APPROVED: <i>William J. Hamilton</i> <small>DESIGNED BY</small> <small>REGISTERED PROFESSIONAL ENGINEER</small>	
DATE: 5/10/2022	
SEAL	
	
DOCUMENT NOT CONSIDERED FINAL UNLESS ALL SIGNATURES COMPLETED	
	
<b>RAMEY KEMP ASSOCIATES</b> <small>5808 Farington Place  Raleigh, North Carolina 27609  Phone: 919-872-5115</small> <small>NC License No. C-0910  www.rameykemp.com</small>	

NAD 83 NA 2011

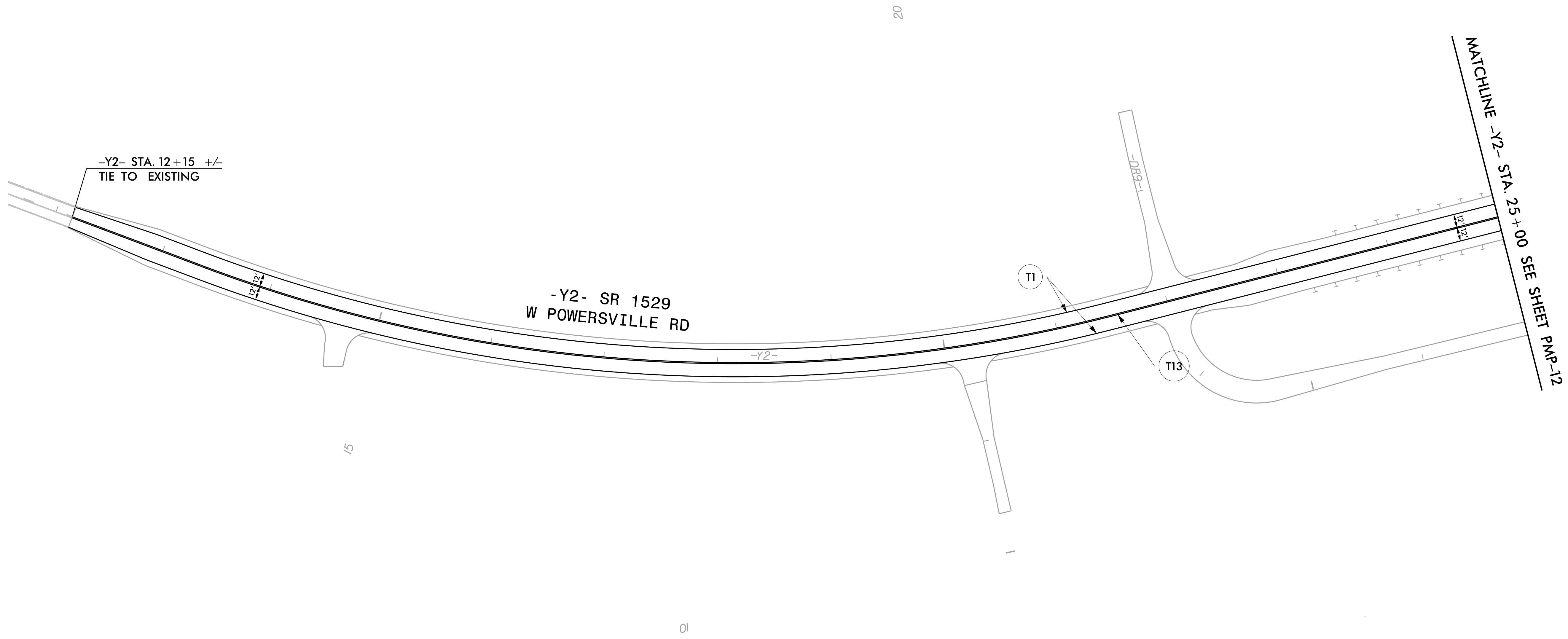

### PAVEMENT MARKING DETAIL

5/10/2022  
I:\15987A\_PMP\_34.dgn  
User: tpope@rka

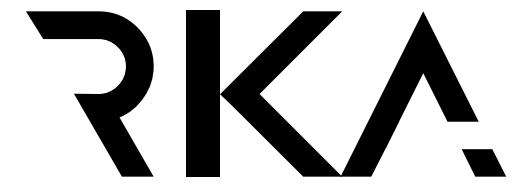
TIP NO.	SHEET NO.
I - 5987A	PMP - 35
Approved by: <i>William J. Hamilton</i> <small>ASSOCIATION # 464856</small>	
DATE: 5/10/2022	
SEAL	
	
<b>DOCUMENT NOT CONSIDERED FINAL UNLESS ALL SIGNATURES COMPLETED</b>	
	
<b>RAMEY KEMP ASSOCIATES</b> <small>5808 Faringdon Place Raleigh, North Carolina 27609 Phone: 919-872-5115</small>	

NAD 83/NA 2011

MATCHLINE -Y2- STA. 33+00 SEE SHEET PMP-12

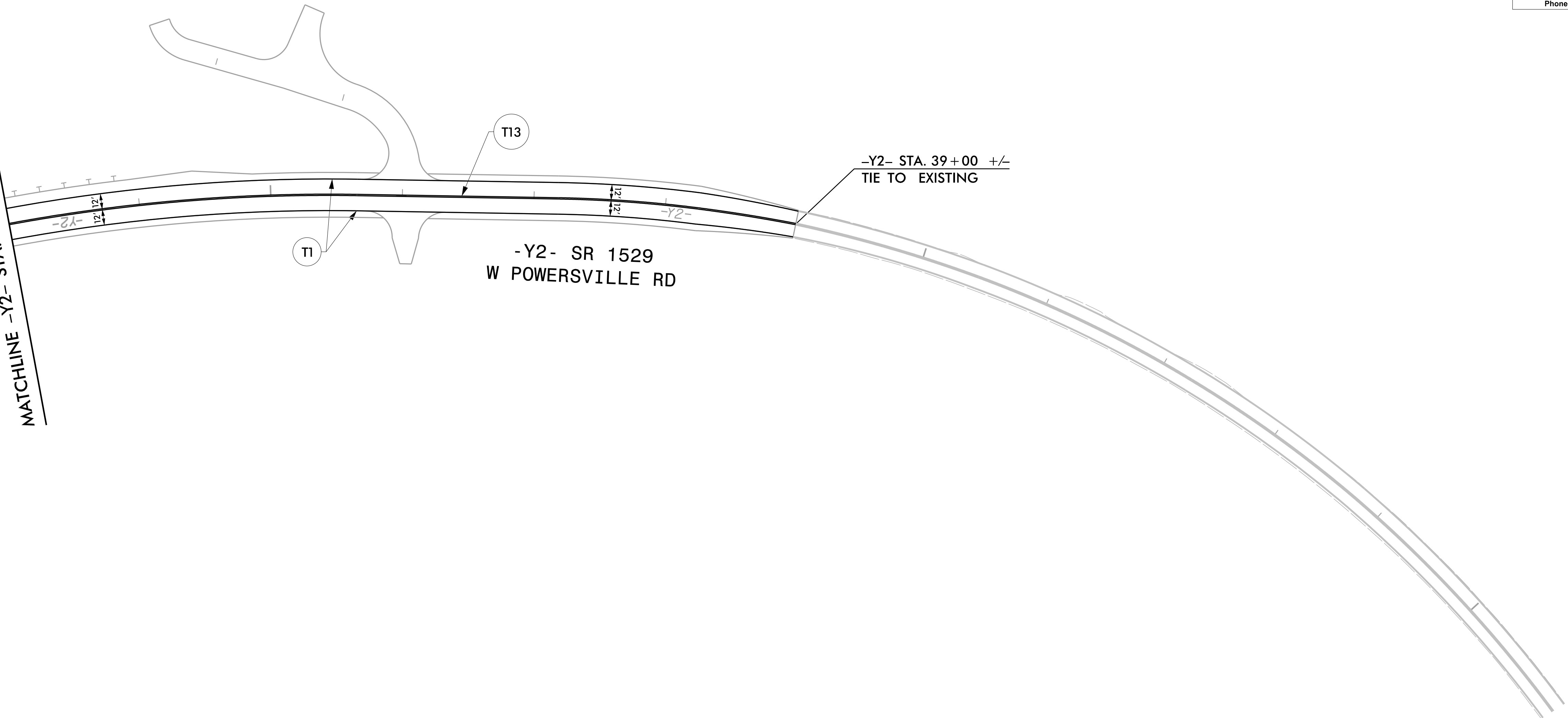

5/10/2022  
I:\15987A\_PMP\_35.dgn  
User: tpope@rka

**PAVEMENT MARKING DETAIL**

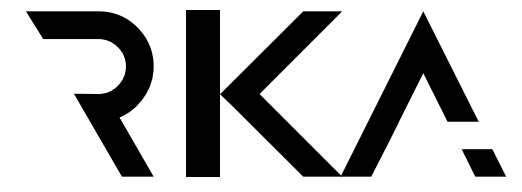
TIP NO.	SHEET NO.
I - 5987A	PMP - 36
APPROVED: <i>William J. Hamilton</i>	
DATE: 5/10/2022	
SEAL	
	
DOCUMENT NOT CONSIDERED FINAL UNLESS ALL SIGNATURES COMPLETED	
	
<b>RAMEY KEMP ASSOCIATES</b> <small>5808 Faringdon Place Raleigh, North Carolina 27609 Phone: 919-872-5115</small>	

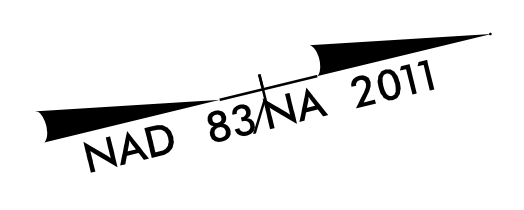

MATCHLINE -SR2- STA. 33+00 SEE SHEET PMP-17

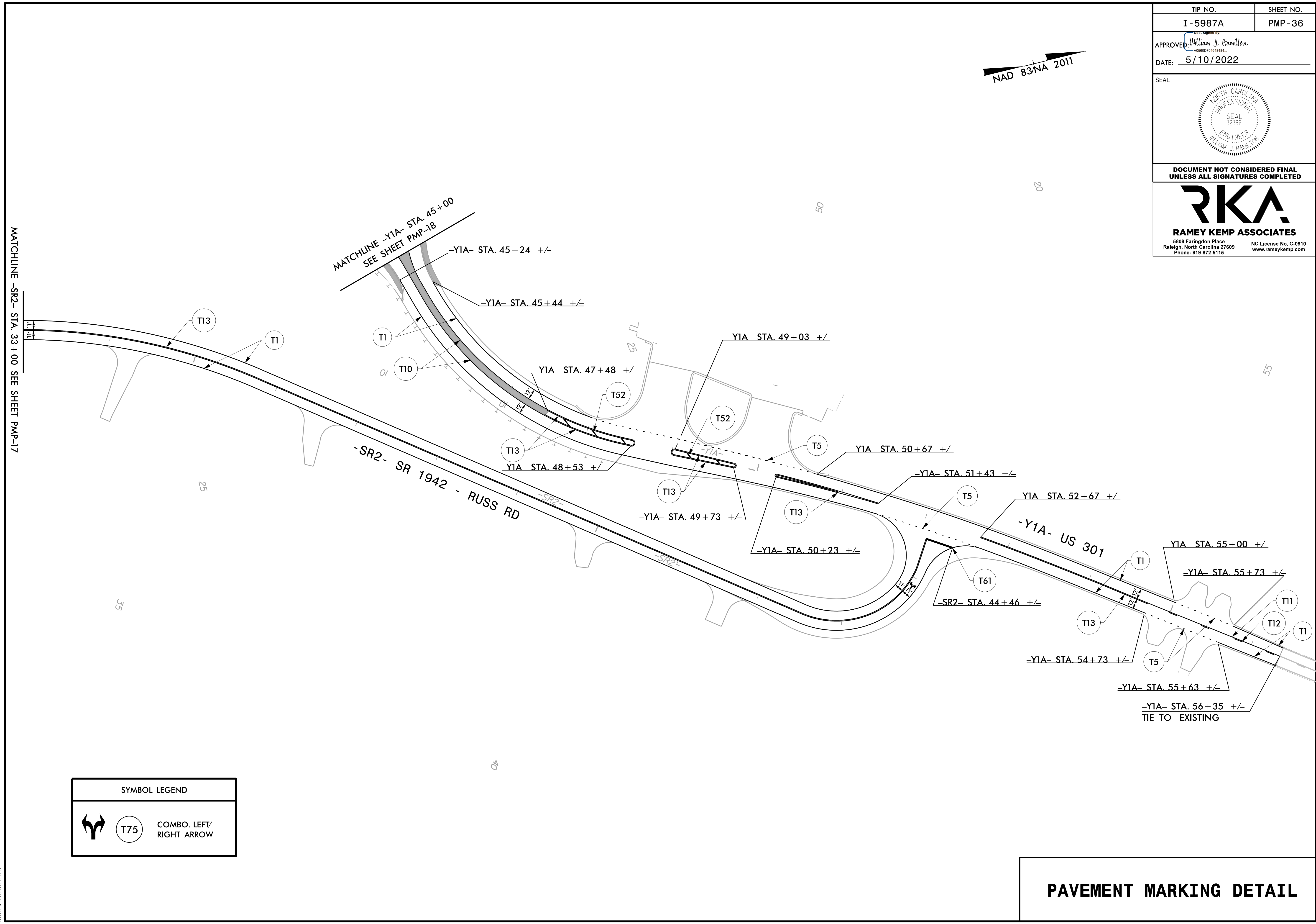

SYMBOL LEGEND	
	T75 COMBO. LEFT/ RIGHT ARROW

**PAVEMENT MARKING DETAIL**

5/10/2022  
I:\15987A\_PMP\_36.dgn  
User: tpope@rka

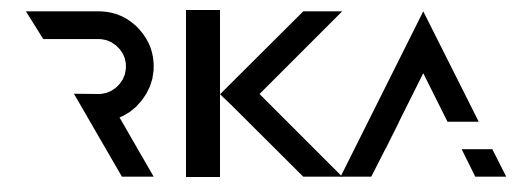

TIP NO.	SHEET NO.
I - 5987A	PMP - 37
APPROVED: <i>William J. Hamilton</i> <small>Professional Engineer License No. 32396</small>	
DATE: 5/10/2022	
SEAL	
	
DOCUMENT NOT CONSIDERED FINAL UNLESS ALL SIGNATURES COMPLETED	
	
<b>RAMEY KEMP ASSOCIATES</b> <small>5808 Faringdon Place Raleigh, North Carolina 27609 Phone: 919-872-5115</small>	

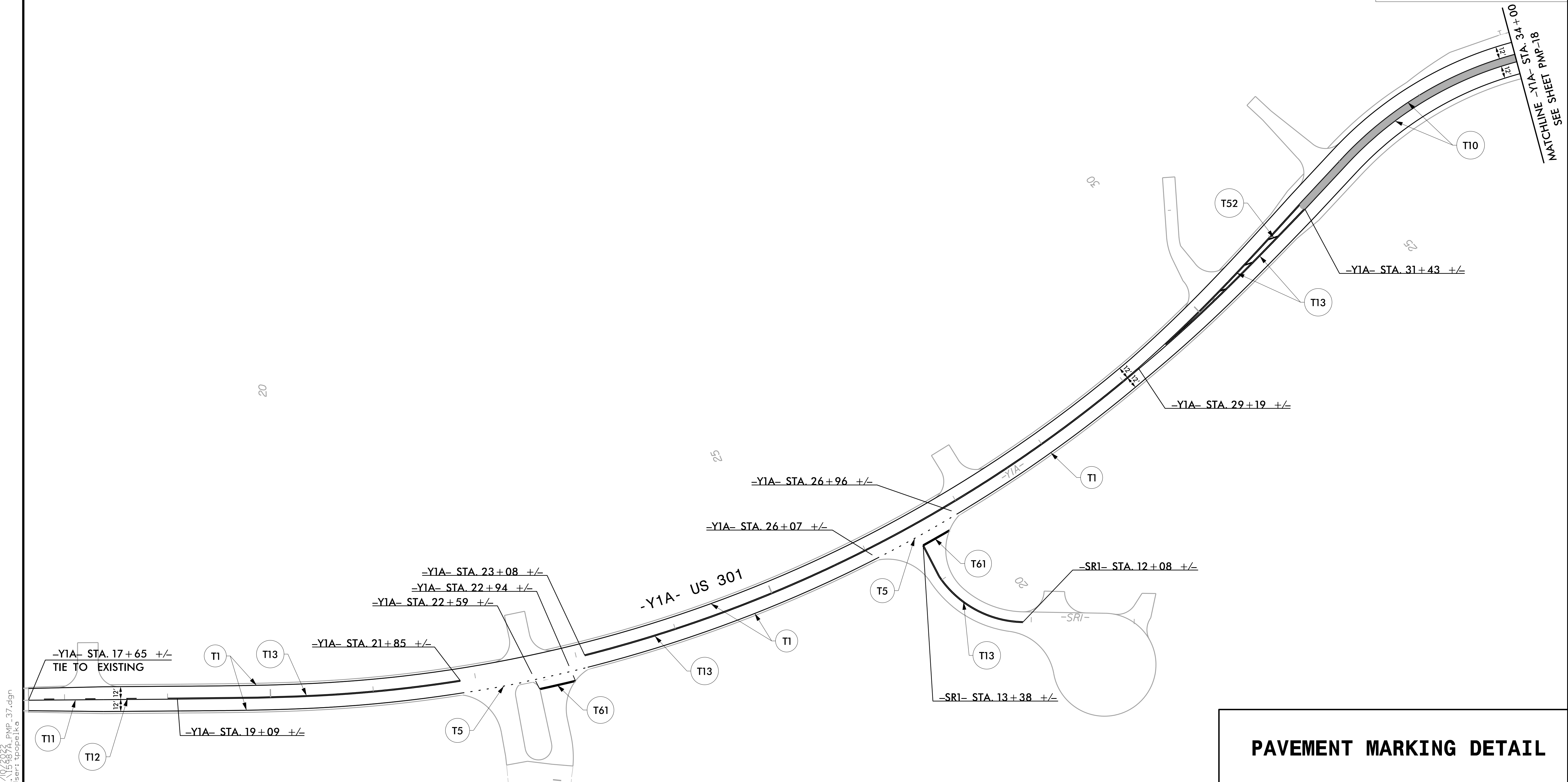
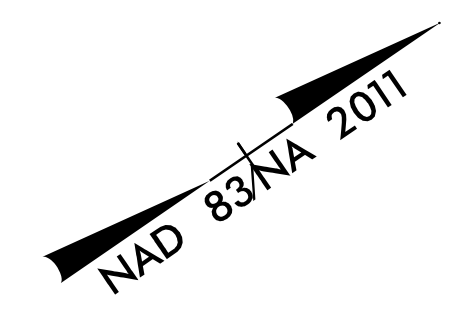

**PAVEMENT MARKING DETAIL**

5/10/2022  
 I:\15987A\_PMP\_37.dgn  
 User: tpope/lka

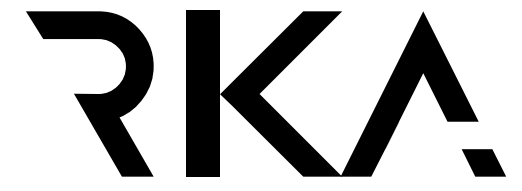

TIP NO.	SHEET NO.
I - 5987A	PMP - 38
APPROVED: <i>William J. Hamilton</i> <small>AS050770464844</small>	
DATE: 5/10/2022	
SEAL	
	
DOCUMENT NOT CONSIDERED FINAL UNLESS ALL SIGNATURES COMPLETED	
	
<b>RAMEY KEMP ASSOCIATES</b> <small>5808 Faringdon Place Raleigh, North Carolina 27609 Phone: 919-872-5115</small> <small>NC License No. C-0910 www.rameykemp.com</small>	

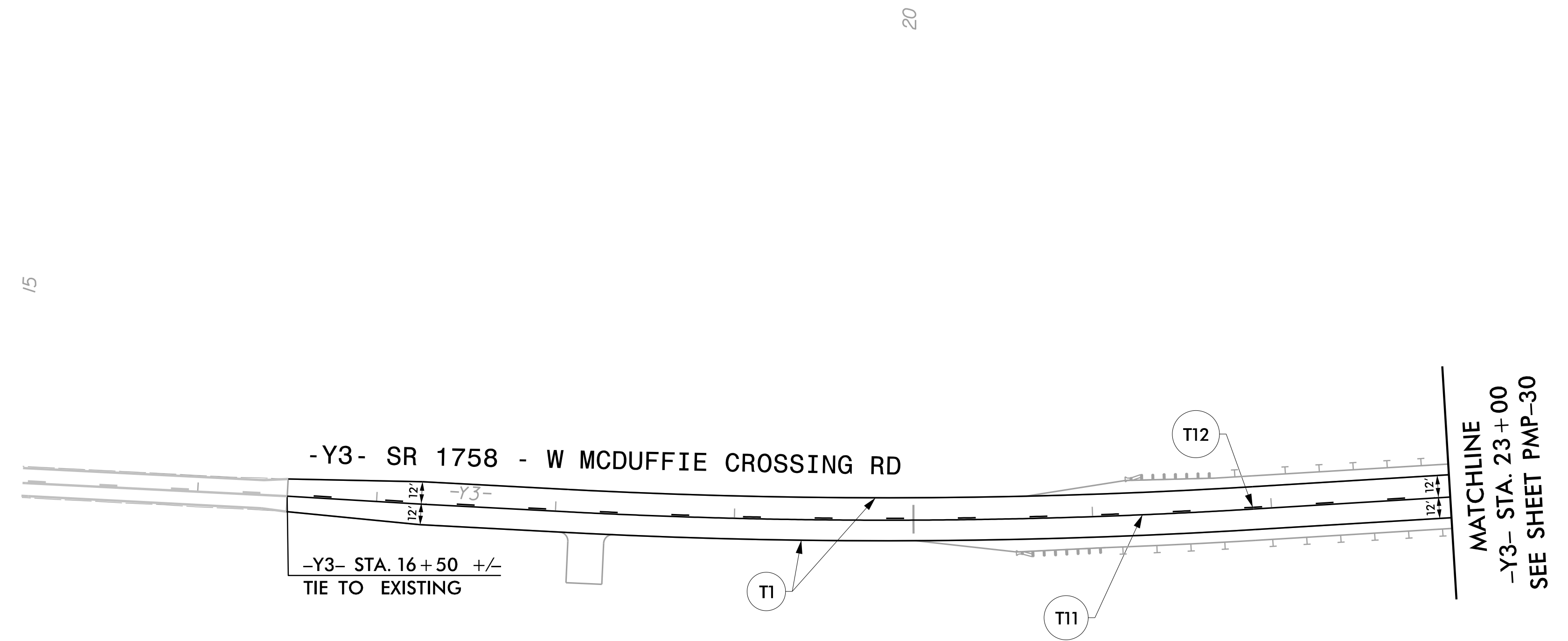

15

20

**PAVEMENT MARKING DETAIL**

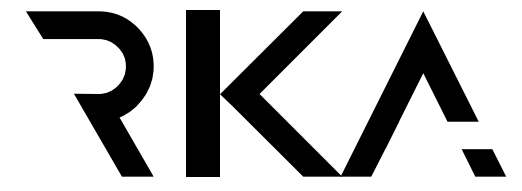
TIP NO.	SHEET NO.
I - 5987A	PMP - 39
APPROVED <i>William J. Hamilton</i> <small>AS060070468484</small>	
DATE: 5/10/2022	
SEAL 	
<b>DOCUMENT NOT CONSIDERED FINAL UNLESS ALL SIGNATURES COMPLETED</b>	
 <b>RAMEY KEMP ASSOCIATES</b> <small>5808 Faringdon Place Raleigh, North Carolina 27609 Phone: 919-872-5115</small>	

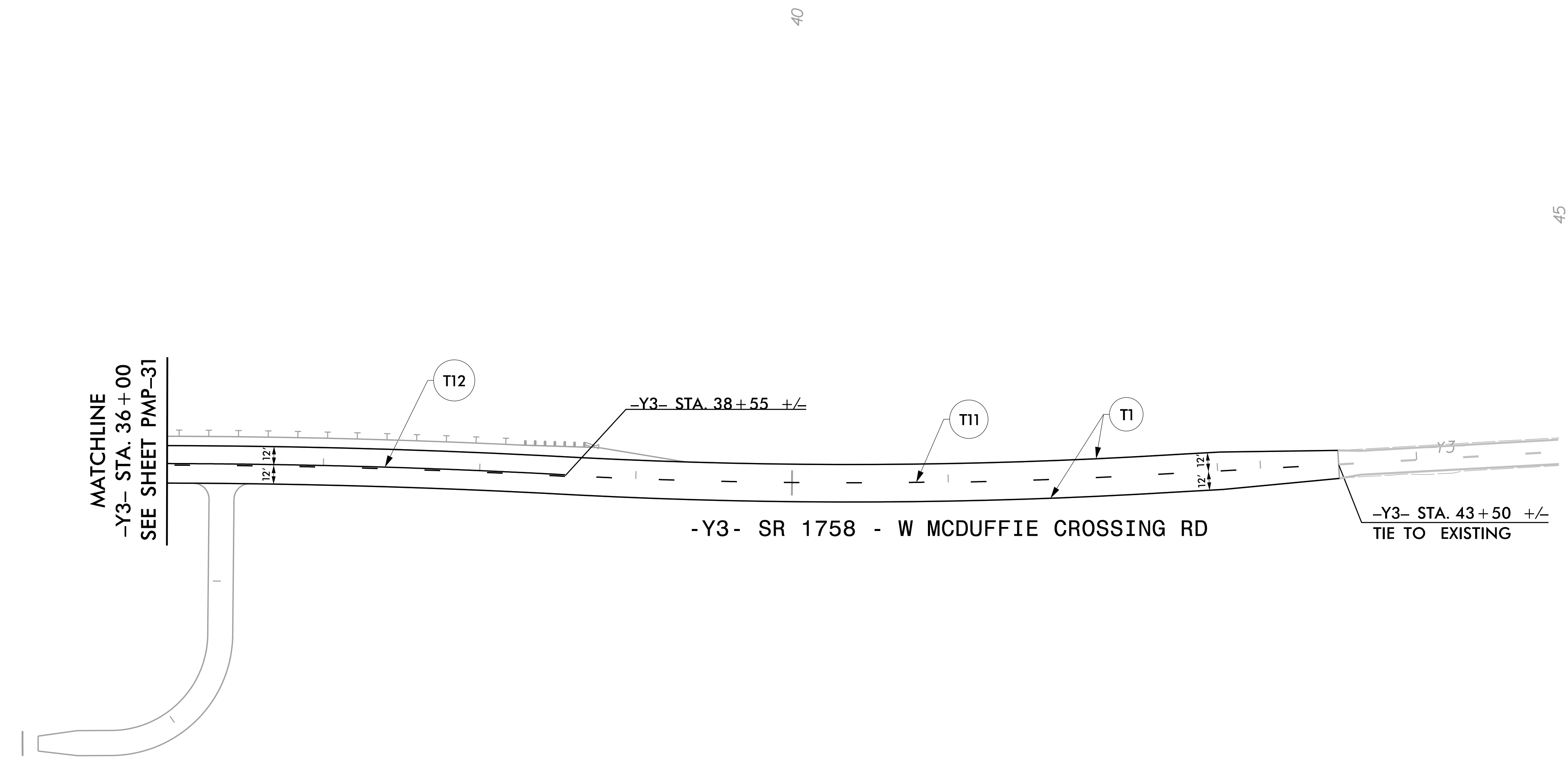
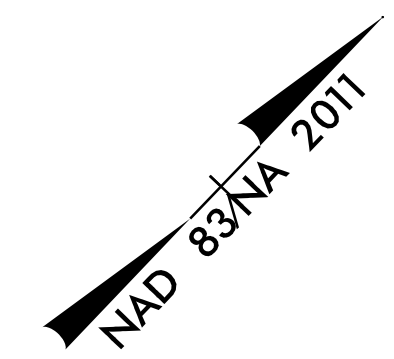

5/10/2022  
 I:\15687A\_PMP\_39.dgn  
 User: tpope@rka

**PAVEMENT MARKING DETAIL**