

**This electronic collection of documents is provided
for the convenience of the user
and is Not a Certified Document –**

**The documents contained herein were originally issued
and sealed by the individuals whose names and license
numbers appear on each page, on the dates appearing
with their signature on that page.**

**This file or an individual page
shall not be considered a certified document.**

STATE OF NORTH CAROLINA
DIVISION OF HIGHWAYS

MECKLENBURG COUNTY

LOCATION: NC 16 (BROOKSHIRE BLVD) AND NORTHERN I-485 INTERCHANGE

TYPE OF WORK: TRAFFIC SIGNALS AND SIGNAL COMMUNICATIONS

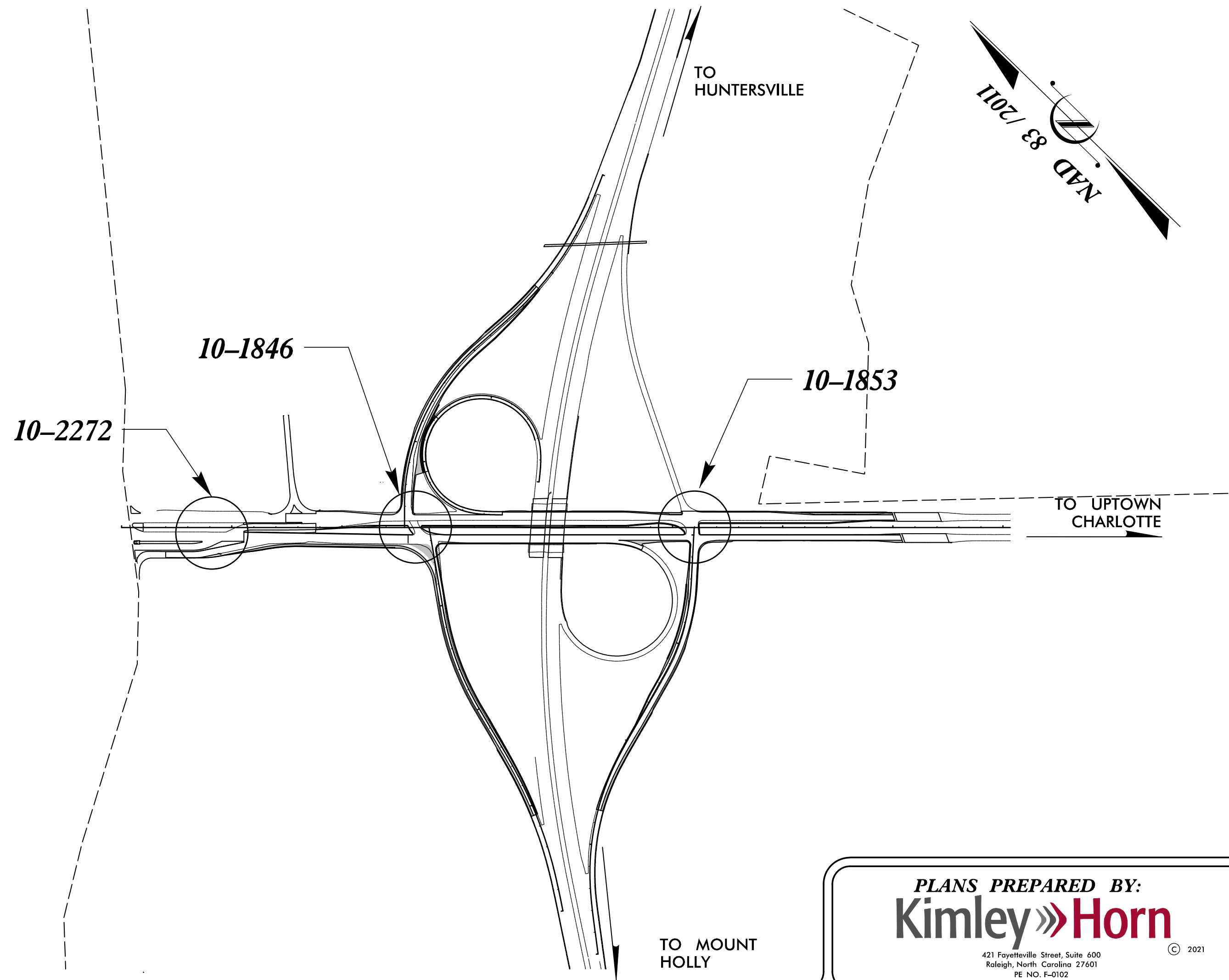
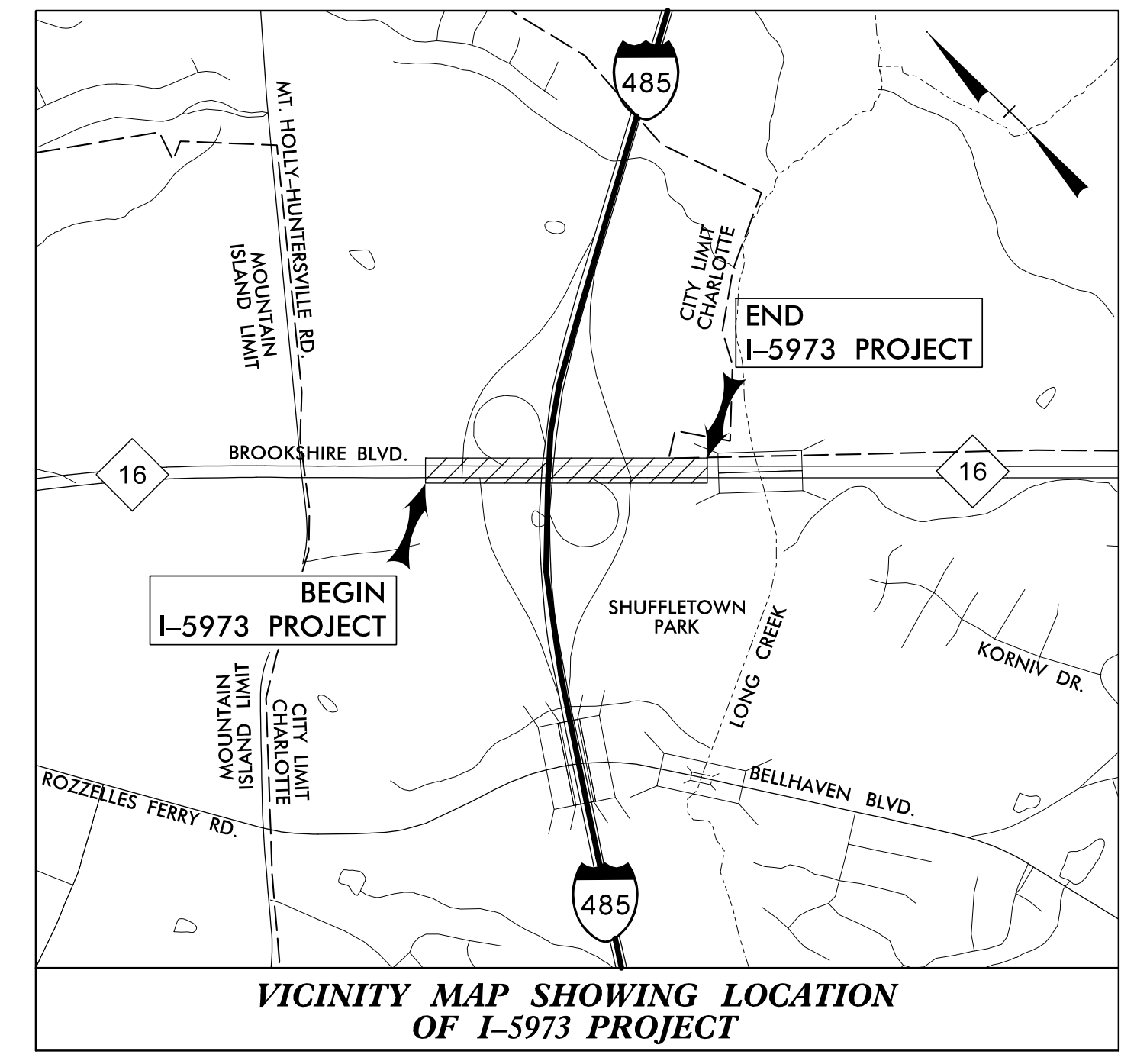

TIP PROJECT: I-5973

CONTRACT: C204658

\\kimley-horn.com\SE_RAL\RAL_TPT0\SIGNALS\01036453_I-5973\I-485_Brookshire\SA - Signal Design\NCDDT_plans\I-5973_sig_tsh.dgn

Sheet #	Reference #	Index of Plans	Location/Description
Sig. 0.0	-----	Title Sheet	
Sig. 1.0-1.3	10-2272	NC 16 (Brookshire Blvd.) at East Cross-over	
Sig. 2.0-2.8	10-1846	NC 16 (Brookshire Blvd.) at I-485 SB Ramp	
Sig. 3.0-3.6	10-1853	NC 16 (Brookshire Blvd.) at I-485 NB Ramp	
Sig. 4.0	-----	Standard Wood Pole Sheet	
M1 - M8	-----	Standard Metal Pole Details	
Cable Routing Plans			
SCP1	-----	Cover Sheet	
SCP2A-SCP2E	-----	General Notes and Details	
SCP3A-SCP3D	-----	Splice Details	
SCP3E	-----	Quantities Tabulations	
SCP4-SCP9	-----	Cable Routing	

NCDOT SIGNAL CONTACT:

Tim Williams, P.E.
CENTRAL REGION SIGNALS ENGINEER

Keith M. Mims, P.E.
ITS & SIGNALS MANAGEMENT ENGINEER

PLANS PREPARED BY:
Kimley»Horn
421 Fayetteville Street, Suite 600
Raleigh, North Carolina 27601
PE NO. F-0102 © 2021

Refer to Roadway Standard Drawings
NCDOT" dated January 2018 and
Standard Specifications for Roads
and Structures" dated January 2018.

Stacie L. Phillips, P.E.
TRAFFIC SIGNAL ENGINEER
Inger Z. VanOsdell
SIGNAL COMMUNICATION ENGINEER

DocuSigned by:
Stacie L. Phillips
SIGNATURE: 2/16/2022 P.E.

Prepared for:

750 N. Greenfield Pkwy, Garner, NC 27529

PHASING DIAGRAM

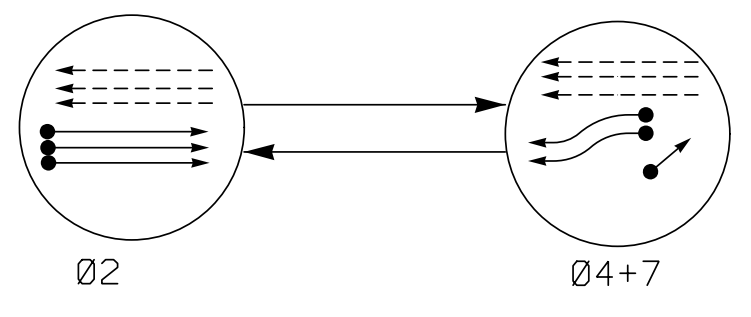

PHASING DIAGRAM DETECTION LEGEND

- DETECTED MOVEMENT
- UNDETECTED MOVEMENT (OVERLAP)
- UNSIGNALIZED MOVEMENT
- PEDESTRIAN MOVEMENT

TABLE OF OPERATION

SIGNAL FACE	PHASE		
	02	04+7	FLASH
21,22,23	↑	R	Y
41,42,43	R	↑	R
71,72	↖	↘	↗

SIGNAL FACE I.D.

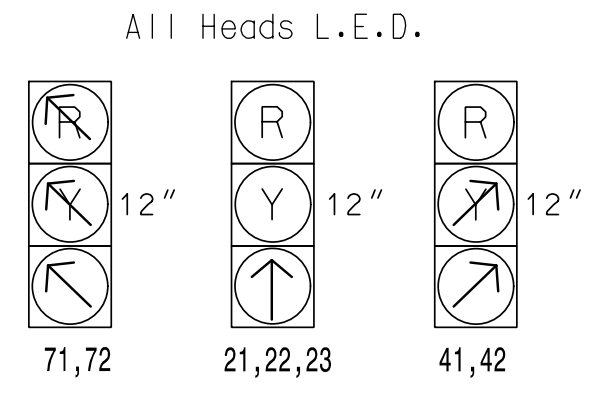

LOOP & DETECTOR INSTALLATION CHART
EOS-2070LX CONTROLLER w/ TS-2 CABINET

LOOP NO.	SIZE (ft)	DIST. FROM STOPBAR (ft)	TURNS	NEW EXISTING	DETECTOR UNITS			DET. TYPE	
					FEATURE	TIME			
2A	6X30	130	3	- Y	2	- Y	-	-	N
2B	6X30	280	3	- Y	2	- Y	-	-	N
4A	6X25	+5	3	Y -	4	- Y	-	-	N
* 4B	6X25	+5	3	Y -	4	- Y	-	-	N
4D	6X6	70	3	Y -	4	- Y	-	-	N
* 4E	6X6	70	3	Y -	4	- Y	-	-	N
7A	6X25	+5	3	- Y	7	- Y	-	-	N
7B	6X25	+5	3	- Y	7	- Y	-	-	N
7C	6X21	70	3	- Y	7	- Y	-	-	N

* INSTALL LOOPS FOR FUTURE USE. THESE LOOPS WILL BE DISABLED IN CONSTRUCTION PHASE 2A AND ENABLED FOR CONSTRUCTION PHASE 2B(SEE INSET).

3 Phase Fully Actuated (Charlotte Signal System)

NOTES

1. Refer to "Roadway Standard Drawings NCDOT" dated January 2018 and "Standard Specifications for Roads and Structures" dated January 2018.
2. Do not program signal for late night flashing operation unless otherwise directed by the Engineer.
3. Set all detector units to presence mode.
4. Locate new cabinet so as not to obstruct sight distance of vehicles turning right on red.
5. Maximum times shown in timing chart are for free-run operation only. Coordinated signal system timing values shall supersede these values.
6. Charlotte Signal System Data: Controller Asset #2272

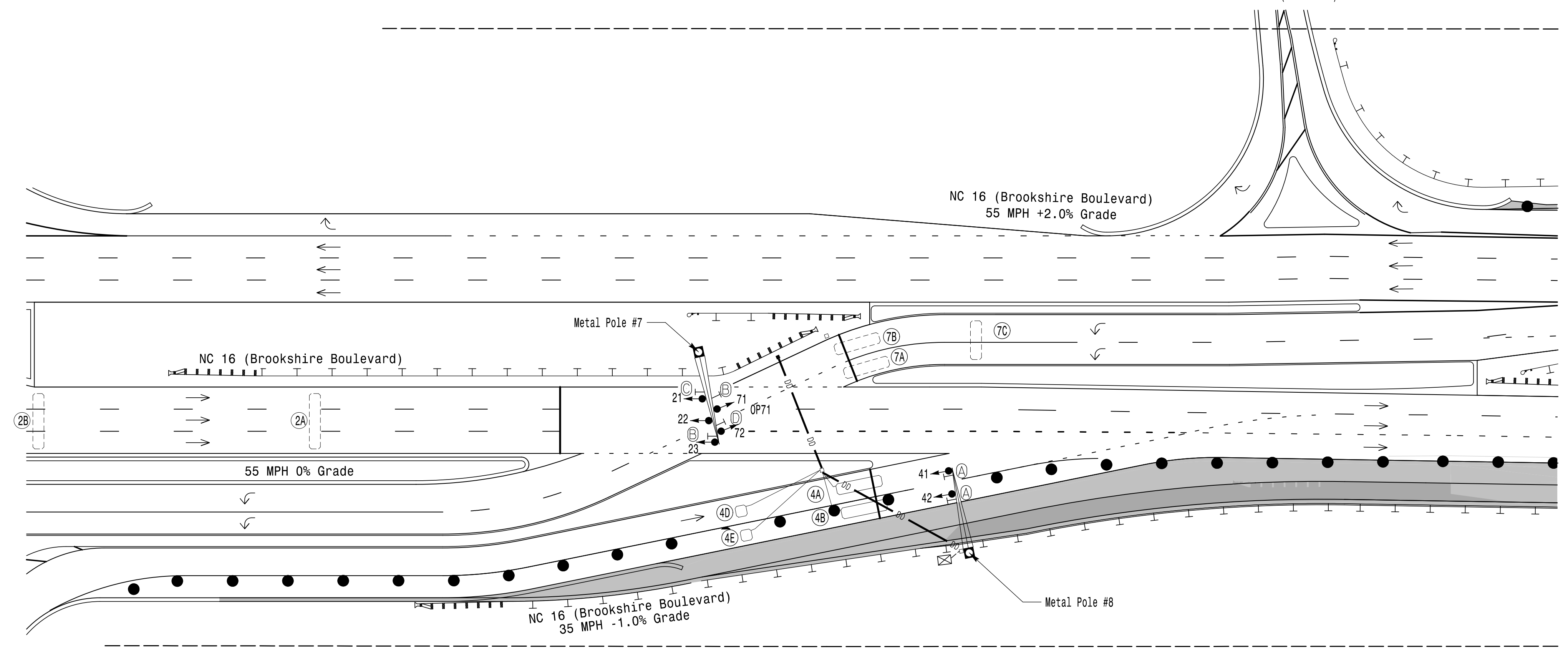

TIMING CHART
EOS-2070LX CONTROLLER

PHASE	02	04	07
MINIMUM GREEN *	14 SEC.	7 SEC.	7 SEC.
VEHICLE EXT. *	2.0 SEC.	3.0 SEC.	3.0 SEC.
YELLOW CHANGE INT.	5.2 SEC.	3.9 SEC.	3.4 SEC.
RED CLEARANCE	2.9 SEC.	1.0 SEC.	3.0 SEC.
MAX. I *	45 SEC.	45 SEC.	45 SEC.
RECALL POSITION	MIN. RECALL	NONE	NONE
LOCK DET.	ON	OFF	OFF
WALK *	- SEC.	- SEC.	- SEC.
PED. CLEAR	- SEC.	- SEC.	- SEC.
VOLUME DENSITY	OFF	OFF	OFF
ACTUATION B4 ADD *	- VEH.	- VEH.	- VEH.
SEC. PER ACTUATION *	- SEC.	- SEC.	- SEC.
MAX. INITIAL *	- SEC.	- SEC.	- SEC.
TIME B4 REDUCTION *	- SEC.	- SEC.	- SEC.
TIME TO REDUCE *	- SEC.	- SEC.	- SEC.
MINIMUM GAP	- SEC.	- SEC.	- SEC.
DUAL ENTRY	OFF	OFF	OFF
SIMULTANEOUS GAP	ON	ON	ON

* These values may be field adjusted. Do not adjust Min Green and Extension times for phases 2 and 6 lower than that is shown. Min Green for all other phases should not be lower than 4 seconds.

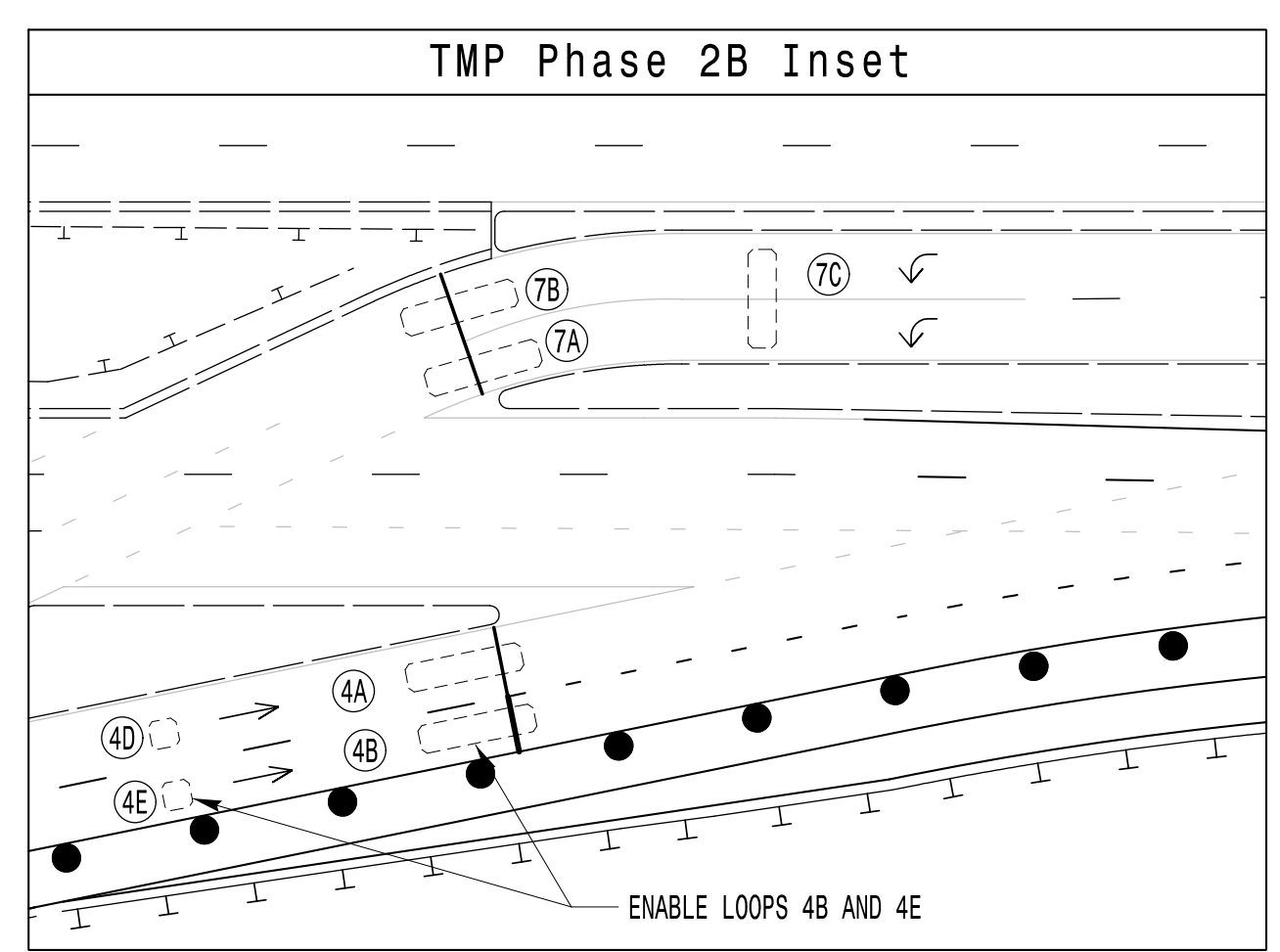

LEGEND

PROPOSED	EXISTING
○ Traffic Signal Head	● Traffic Signal Head
○ Modified Signal Head	N/A
○ Sign	N/A
○ Pedestrian Signal Head With Push Button & Sign	N/A
○ Metal Pole with Mastarm	○ Metal Pole with Mastarm
○ Inductive Loop Detector	○ Inductive Loop Detector
○ Controller & Cabinet	○ Controller & Cabinet
○ Junction Box	○ Junction Box
○ 2-in Underground Conduit	○ 2-in Underground Conduit
N/A Right of Way	N/A Right of Way
→ Directional Arrow	→ Directional Arrow
--- Directional Drill	N/A
N/A Guardrail	N/A
(A) "NO TURN ON RED" Sign (R10-11)	(A) "NO TURN ON RED" Sign (R10-11)
(B) NO RIGHT SYMBOL SIGN (R3-2)	(B) NO RIGHT SYMBOL SIGN (R3-2)
(C) No Left Turn Sign (R3-2)	(C) No Left Turn Sign (R3-2)
(D) No U-Turn Sign (R3-4)	(D) No U-Turn Sign (R3-4)
Construction Zone	Construction Zone
Construction Zone Drums	Construction Zone Drums

Signal Upgrade - Temporary Design 1
TMP Phase 2A

Prepared For the Offices of:

NC 16 (Brookshire Boulevard) at East Cross-over

Division 10 Mecklenburg County Charlotte

PLAN DATE: September 2021 REVIEWED BY: SL Phillips

PREPARED BY: SP Pennington REVIEWED BY:

REVISIONS: INIT. DATE

DocuSigned by:

 2/16/2022

SIG. INVENTORY NO. 10-2272T

PLANS PREPARED IN THE OFFICE OF:
Kimley»Horn
 NC License #F-0102
 421 Fayetteville Street, Suite 600
 Raleigh, NC 27601
 (919) 677-2000

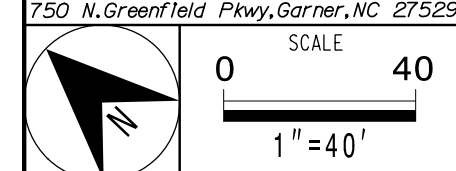

EDI MODEL MMU2-16LEip MALFUNCTION MANAGEMENT UNIT PROGRAMMING DETAIL *(program card and tables as shown)*

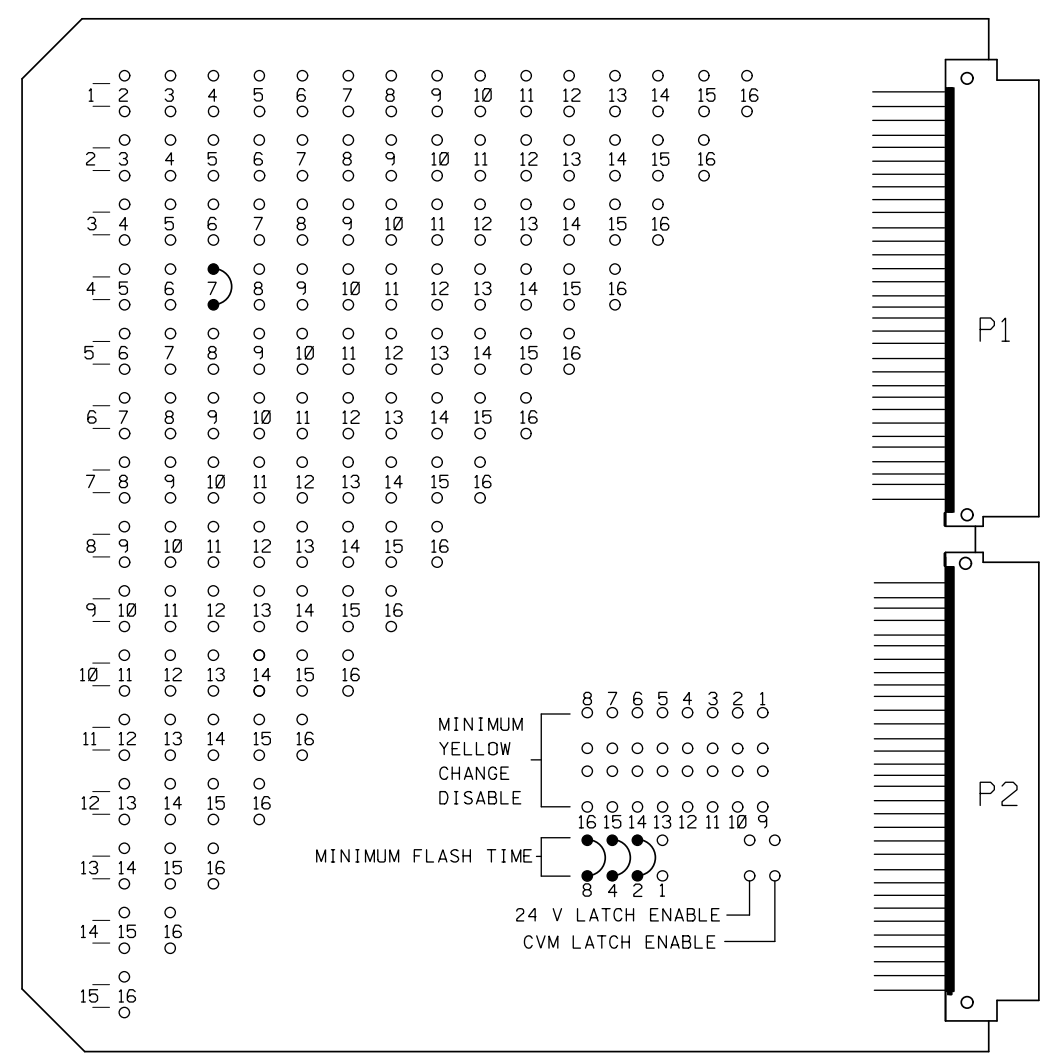

MMU PROGRAMMING CARD

CHANNEL NUMBER	ENABLE/DISABLE
1	DISABLE
2	ENABLE
3	DISABLE
4	ENABLE
5	DISABLE
6	DISABLE
7	ENABLE
8	DISABLE
9	DISABLE
10	DISABLE
11	DISABLE
12	DISABLE
13	DISABLE
14	DISABLE
15	DISABLE
16	DISABLE

OPTION	SETTING
RECURRENT PULSE	ON
WALK DISABLE	OFF
LOG CVM FAULTS	ON
EXTERN WATCHDOG	OFF
24V-2=12VDC	OFF
PGM CARD MEMORY	ON
LEDguard	ON
FORCE TYPE 16	OFF
TYPE12-SDLCL	OFF
VM 3x/Day Latch	ON

FLASHING YELLOW ARROW	
CONFIG MODE	B
ENABLE CHANNEL PAIR, FYA	
CH 1-13	OFF
CH 3-14	OFF
CH 5-15	OFF
CH 7-16	OFF
RED/YEL INPUT ENABLE	
CH 1	OFF
CH 3	OFF
CH 5	OFF
CH 7	OFF
FLASH RATE FAULT	OFF
FYA TRAP DETECT	OFF

MMU PROGRAMMING NOTE
ENSURE YELLOW CHANGE PLUS RED CLEARANCE MONITORING IS ENABLED FOR ALL CHANNELS.

DETECTOR RACK SET-UP DETAIL

INSERT DETECTOR CARDS IN RACK ACCORDING TO THE DETAIL SHOWN BELOW. PARTICULAR DETECTOR CHANNELS WILL CALL PHASES INDICATED.

RACK #1	CH1		CH2		SLOT		SLOT		SLOT		SLOT		SLOT	
	CHI	CHI	CHI	CHI	CHI	CHI	CHI	CHI	CHI	CHI	CHI	CHI	CHI	CHI
BIU	L3	L1	L7	L5	L11	L9	SLOT	SLOT	SLOT	SLOT	SLOT	SLOT	SLOT	SLOT
	Ø4	Ø2	Ø7	NOT USED	NOT USED	Ø4								
	4A	2A	7B			4D	EMPTY	EMPTY	EMPTY	EMPTY	EMPTY	EMPTY	EMPTY	EMPTY
	L4	L2	L8	L6	L12	L10								
	NOT USED	Ø2	Ø7	Ø7	NOT USED	NOT USED								
		2B	7C	7A										

WIRE LOOPS TO TERMINALS ON LOOP PANEL AS SHOWN IN THE CHART BELOW

LOOP NO.	LOOP PANEL TERMINALS
2A	L1A,L1B
2B	L2A,L2B
4A	L3A,L3B
NU	L4A,L4B
NU	L5A,L5B
7A	L6A,L6B
7B	L7A,L7B
7C	L8A,L8B
4D	L9A,L9B
NU	L10A,L10B
NU	L11A,L11B
NU	L12A,L12B
NU	L13A,L13B
NU	L14A,L14B
NU	L15A,L15B
NU	L16A,L16B

NOTE
BE SURE TO PROGRAM DETECTOR TYPES AND TIMERS (EXTEND AND DELAY) AS SHOWN ON THE SIGNAL PLANS.

PROGRAM CONTROLLER DETECTORS ACCORDING TO THE SCHEDULE SHOWN IN THE CHART BELOW

CONTROLLER DETECTOR NO.	FUNCTION	TIMING	
		FEATURE	TIME(SEC)
1	Ø2	-	-
2	Ø2	-	-
3	Ø4	-	-
4	-	-	-
5	-	-	-
6	Ø7	-	-
7	Ø7	-	-
8	Ø7	-	-
9	Ø4	-	-
10	-	-	-
11	-	-	-
12	-	-	-
13	-	-	-
14	-	-	-
15	-	-	-
16	-	-	-

LOAD SWITCH ASSIGNMENT DETAIL *(program controller according to schedule in chart below)*

LOAD SWITCH NUMBER	FUNCTION
1	-
2	Ø2
3	-
4	Ø4
5	-
6	-
7	Ø7
8	-
9	-
10	-
11	-
12	-
13	-
14	-
15	-
16	-

UNUSED LOAD SWITCH CHANNELS SHALL BE DISABLED IN CONTROLLER PROGRAMMING

NOTES

- To prevent "flash-conflict" problems, wire all unused load switches to flash red. Verify that signal heads flash in accordance with the signal plans.
- To prevent red failures on unused monitor channels, tie unused load switch red outputs 1,3,5,6,8,9,10,11,12,13,14,15 & 16 to load switch AC+ by inserting a jumper plug in the unused load switch socket from pin 1 (LS AC+) to pin 3 (RED out). Make sure all flash transfer relays are in place.
- Program controller to start up in Phase 2 Green.
- Set power-up flash time to 12 seconds and implement on the malfunction management unit. Set controller power-up flash time to 22 seconds.
- Enable simultaneous gap-out feature, on controller unit, for all phases.
- Program detectors in accordance with the manufacturer's instructions to accomplish the detection schemes shown on the signal design plans.
- Program detector call delay and extension timing on the controller, unless otherwise specified.
- Set all detector card unit channels to "presence" mode.
- The cabinet and controller are a part of the Charlotte Signal System.

FIELD CONNECTION HOOK-UP CHART

PHASE	1	2	3	4	5	6	7	8	2 PED	4 PED	6 PED	8 PED	OLA	OLB	OLC	OLD
SIGNAL HEAD NO.	NU	21,22,23	NU	41,42	NU	NU	71,72	NU	NU	NU	NU	NU	NU	NU	NU	NU
RED		2R		4R												
YELLOW		2Y														
GREEN																
RED ARROW							7R									
YELLOW ARROW				4Y			7Y									
GREEN ARROW		2G		4G			7G									

NU = NOT USED

ECONOLITE EOS SPECIAL MMU PROGRAMMING *(program controller as shown)*

- From Main Menu select
- From CONFIGURATION Submenu select
- From Cabinet Submenu select

CAUTION!

Set intersection to Flash before attempting to enter or change any MMU programming data. This programming and that of the MMU programming card must match exactly. If they do not, the intersection will be placed into Flash.

MMU PROGRAM [MANUAL]
CH 6	5
1
2
3
4 X ..
5
6
7
8
9
10
11
12
13
14
15

END PROGRAMMING

THIS ELECTRICAL DETAIL IS FOR THE SIGNAL DESIGN: 10-2272T
DESIGNED: September 2021
SEALED: 2/16/2022
REVISED:

Temporary Design Electrical Detail

<p>Prepared for: Transportation Mobility and Safety Division NORTH CAROLINA DEPARTMENT OF TRANSPORTATION STATE DESIGN SECTION</p>	NC 16 (Brookshire Boulevard) at East Cross-Over		
	Division 10 Mecklenburg County Charlotte		
	PLAN DATE: September 2021 PREPARED BY: SP Pennington	REVIEWED BY: SL Phillips REVIEWED BY:	
	REVISIONS:	INIT: DATE:	
PLANS PREPARED IN THE OFFICE OF: Kimley-Horn NC License #F-0102 421 Fayetteville Street, Suite 600 Raleigh, NC 27601 (919) 677-2000			DocuSigned by: SIGNATURE DATE: 2/16/2022 SIG. INVENTORY NO. 10-2272T

*****ACTUAL TIME*****
*****DRAWING NO.*****
*****USER NAME*****

PHASING DIAGRAM

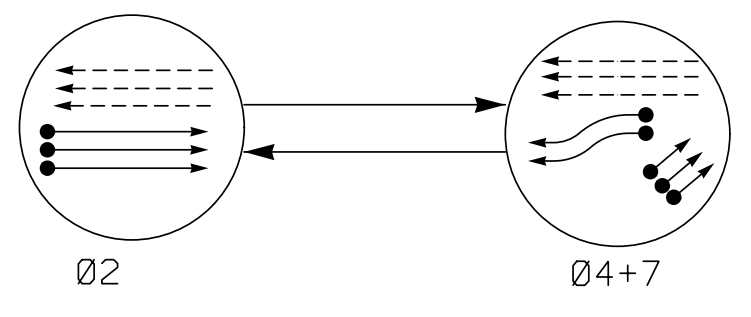

PHASING DIAGRAM DETECTION LEGEND

- ← DETECTED MOVEMENT
- ← UNDETECTED MOVEMENT (OVERLAP)
- ← UNSIGNALIZED MOVEMENT
- ⋯ ← PEDESTRIAN MOVEMENT

SIGNAL FACE	PHASE		
	02	04+7	FLASH
21,22,23	↑	R	Y
41,42,43	R	↘	R
71,72	↘	↘	↘

SIGNAL FACE I.D.

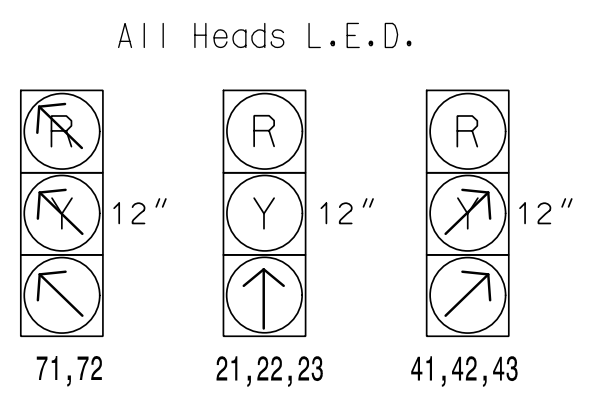

LOOP & DETECTOR INSTALLATION CHART
EOS-2070LX CONTROLLER w/ TS-2 CABINET

LOOP NO.	SIZE (ft)	DIST. FROM STOPBAR (ft)	TURNS	NEW EXISTING	DETECTOR UNITS			DET. TYPE	
					NEMA PHASE	NEW EXISTING	TIMING FEATURE TIME		
2A	6X30	130	3	- Y	2	- Y	-	-	N
2B	6X30	280	3	- Y	2	- Y	-	-	N
4A	6X25	+5	3	- Y	4	- Y	-	-	N
4B	6X25	+5	3	- Y	4	- Y	-	-	N
4C	6X25	+5	3	Y	- 4	Y	-	-	N
4D	6X6	70	3	- Y	4	- Y	-	-	N
4E	6X6	70	3	- Y	4	- Y	-	-	N
4F	6X6	70	3	Y	- 4	Y	-	-	N
7A	6X25	+5	3	- Y	7	- Y	-	-	N
7B	6X25	+5	3	- Y	7	- Y	-	-	N
7C	6X21	70	3	- Y	7	- Y	-	-	N

3 Phase Fully Actuated (Charlotte Signal System)

NOTES

- Refer to "Roadway Standard Drawings NCDOT" dated January 2018 and "Standard Specifications for Roads and Structures" dated January 2018.
- Do not program signal for late night flashing operation unless otherwise directed by the Engineer.
- Set all detector units to presence mode.
- Maximum times shown in timing chart are for free-run operation only. Coordinated signal system timing values shall supersede these values.
- Charlotte Signal System Data: Controller Asset #2272

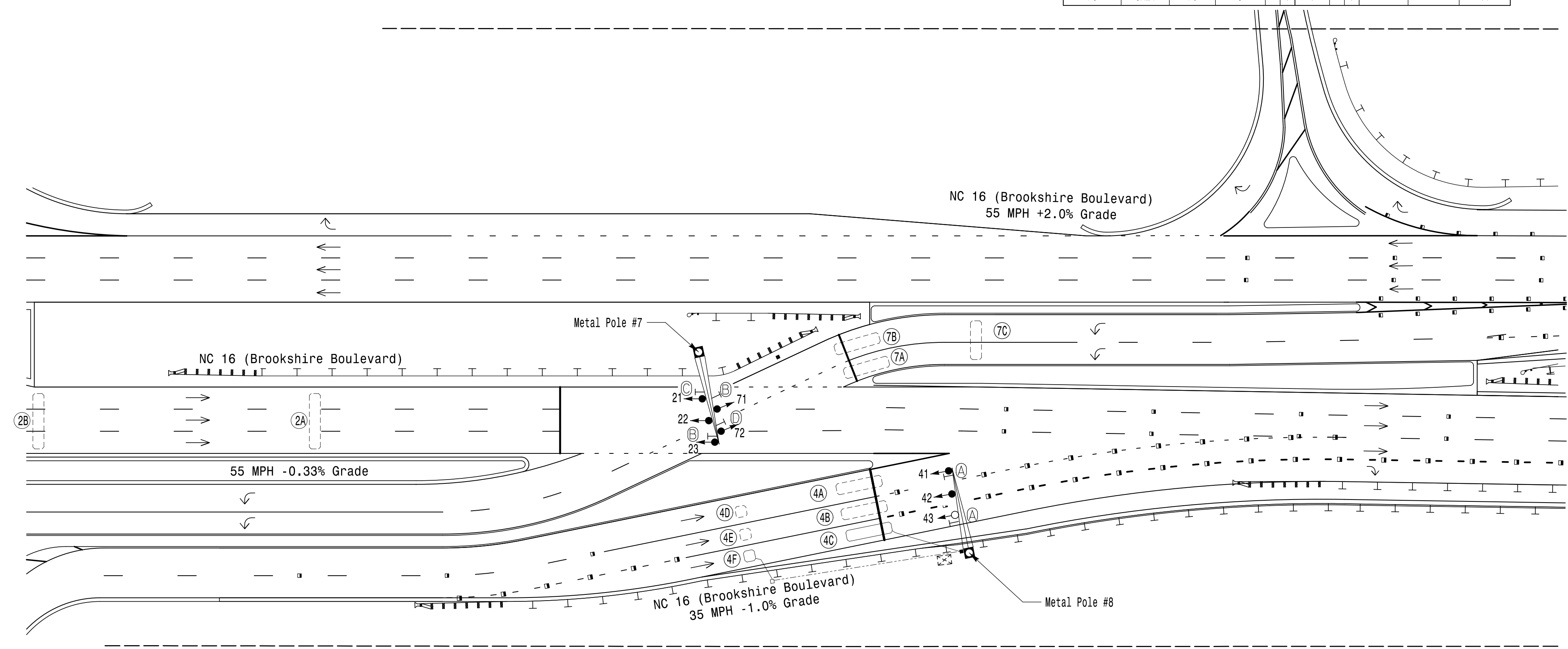

TIMING CHART EOS-2070LX CONTROLLER			
PHASE	02	04	07
MINIMUM GREEN *	14 SEC.	7 SEC.	7 SEC.
VEHICLE EXT. *	2.0 SEC.	3.0 SEC.	3.0 SEC.
YELLOW CHANGE INT.	5.2 SEC.	3.9 SEC.	3.4 SEC.
RED CLEARANCE	2.9 SEC.	1.0 SEC.	3.0 SEC.
MAX. I *	45 SEC.	45 SEC.	45 SEC.
RECALL POSITION	MIN. RECALL	NONE	NONE
LOCK DET.	ON	OFF	OFF
WALK *	- SEC.	- SEC.	- SEC.
PED. CLEAR	- SEC.	- SEC.	- SEC.
VOLUME DENSITY	OFF	OFF	OFF
ACTUATION B4 ADD *	- VEH.	- VEH.	- VEH.
SEC. PER ACTUATION *	- SEC.	- SEC.	- SEC.
MAX. INITIAL *	- SEC.	- SEC.	- SEC.
TIME B4 REDUCTION *	- SEC.	- SEC.	- SEC.
TIME TO REDUCE *	- SEC.	- SEC.	- SEC.
MINIMUM GAP	- SEC.	- SEC.	- SEC.
DUAL ENTRY	OFF	OFF	OFF
SIMULTANEOUS GAP	ON	ON	ON

* These values may be field adjusted. Do not adjust Min Green and Extension times for phases 2 and 6 lower than that is shown. Min Green for all other phases should not be lower than 4 seconds.

PROPOSED		EXISTING	
○ →	Traffic Signal Head	● →	N/A
○ →	Modified Signal Head	○ →	N/A
⊥	Sign	⊥	N/A
⊥	Pedestrian Signal Head With Push Button & Sign	⊥	N/A
⊥	Metal Pole with Mastarm	⊥	N/A
⊥	Inductive Loop Detector	⊥	N/A
⊥	Controller & Cabinet	⊥	N/A
⊥	Junction Box	⊥	N/A
⊥	2-in Underground Conduit	⊥	N/A
N/A	Right of Way	---	N/A
→	Directional Arrow	→	N/A
—	Directional Drill	—	N/A
N/A	Guardrail	—	N/A
(A)	"NO TURN ON RED" Sign (R10-11)	(A)	N/A
(B)	NO RIGHT SYMBOL SIGN (R3-2)	(B)	N/A
(C)	No Left Turn Sign (R3-2)	(C)	N/A
(D)	No U-Turn Sign (R3-4)	(D)	N/A

Signal Upgrade - Final Design

DOCUMENT NOT CONSIDERED FINAL UNLESS ALL SIGNATURES COMPLETED

PLANS PREPARED IN THE OFFICE OF:
Kimley»Horn
NC License #F-0102
421 Fayetteville Street, Suite 600
Raleigh, NC 27601
(919) 677-2000

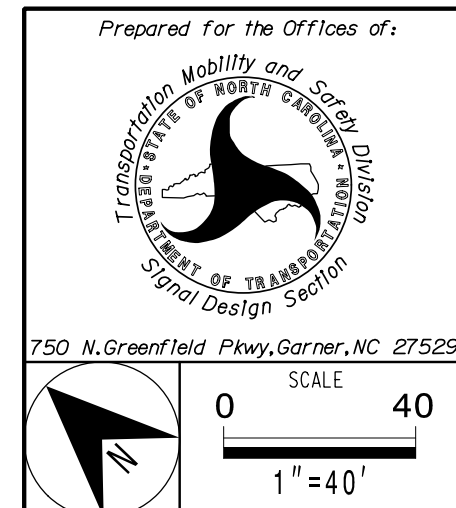

Prepared For the Offices of:		NC 16 (Brookshire Boulevard) at East Cross-over	
Division 10 Mecklenburg County Charlotte		PLAN DATE: September 2021	
REVIEWED BY: SP Pennington		REVIEWED BY: SL Phillips	
REVISIONS	INIT.	DATE	

DocuSigned by:
Stage L Phillips
SIGNATURE
DATE: 2/16/2022
SIG. INVENTORY NO. 10-2272

TIP PROJECT: I-5973

CONTRACT: C204658

INDEX OF SHEETS

Cover Sheet.....	SIG2.0
Temp 1 Signal Plans	SIG2.1
Temp 1 Signal Details	SIG2.2
Temp 2 Signal Plans	SIG2.3
Temp 2 Signal Details	SIG2.4
Final Signal Plans	SIG2.5
Final Signal Details	SIG2.6
Splice Detail	SIG2.7
Utility/Metal Pole Detail.....	SIG2.8

TOTAL SHEETS 9



Signal Plans of
BROOKSHIRE BLVD. @ I-485 OUTER RAMP
 CDOT Signal ID 000895
 NCDOT 10-1846

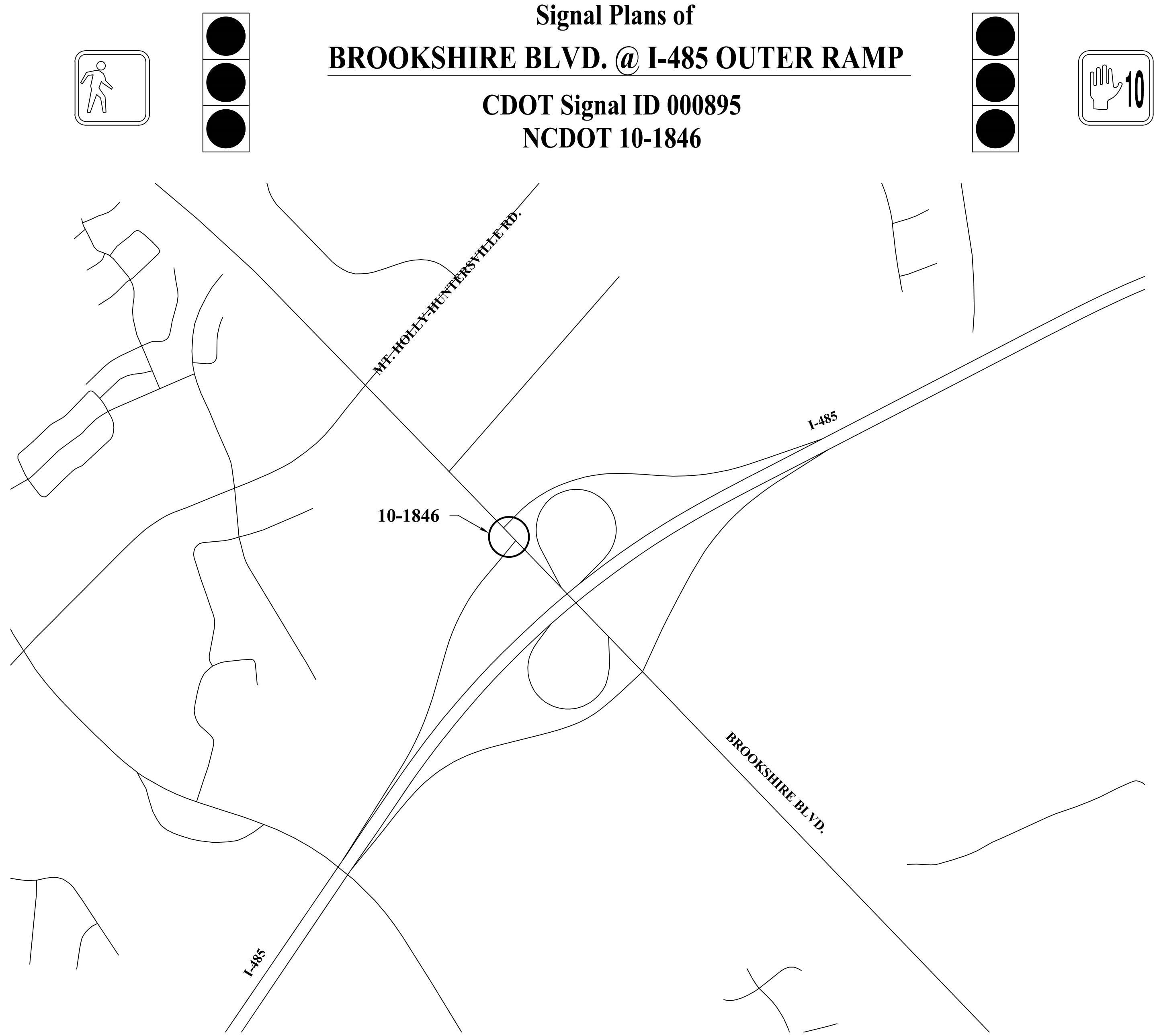

VICINITY MAP (NTS)

DOCUMENT NOT CONSIDERED FINAL UNLESS ALL SIGNATURES COMPLETED

PROJECT REFERENCE NO.	I-5973
SHEET NO.	SIG. 2.0

LEGEND		
PROPOSED	DESCRIPTION	EXISTING
	CONTROL BOX	
	METER PEDESTAL	
	PULL BOX	
	STEEL POLE	
	MAST ARM	
	PED PEDESTAL	
	UTILITY POLE	
	ANCHOR	
	SIGNAL HEAD	
	VIDEO CAMERA	
	OPTICOM	
	OBSERVATION CAM	
	DETECTOR	
	CONDUIT	
	INTERCONNECT	
	EDGE OF PVMT.	
	CURB & GUTTER	
	TUBULAR MARKER	
	GROUND SIGN	
	OVERHEAD SIGN	
	DOUBLE YELLOW	
	STOP BAR	
	WHITE SKIP	
	WHITE MINI	
	PAVEMENT ARROW	
	PROPERTY LINE	
	ROW	

PULLBOX ID		
	SIZE	PULLBOX TYPE
①	13"x24"x12"	LOOP
②	17"x30"x24"	FIBER OPTIC
③	24"x36"x24"	CONTROLLER / FIBER
④	30"x48"x36"	CONTROLLER
⑤	24"x24"x12"	CONTROLLER
⑥	36"x36"x12"	CONTROLLER

NOTE:
 PULLBOX MATERIAL MUST MEET OR EXCEED THE 1998 CDOT TRAFFIC SIGNAL SPECIFICATIONS.

PLANS PREPARED BY:



PLAN NOTES

- ALL PAVEMENT MARKING DIMENSIONS ARE APPROXIMATE.
- SIGNAL SHALL BE INSTALLED IN ACCORDANCE WITH THE LATEST NCDOT STANDARD SPECIFICATIONS AND CDOT TRAFFIC SIGNAL SPECIAL PROVISIONS.
- PED SIGNALS WITH PUSHBUTTONS WILL BE LABELED "PB" (FOR EXAMPLE PB21, PB22)
- COUNTDOWN PEDESTRIAN SIGNALS SHALL COUNT DOWN FLASHING DON'T WALK ONLY.

PE SEAL



DocuSigned by: SL Phillips 2/16/2022

PROJECT TEAM

DESIGNER:	SP PENNINGTON
PROJECT MANAGER:	SL PHILLIPS, P.E.

SHEET 2.0



BROOKSHIRE BLVD. @ I-485 OUTER RAMP Signal ID 00895 / NCDOT 10-1846

NO.	DATE	BY	REVISION DESCRIPTION

DOCUMENT NOT CONSIDERED FINAL UNLESS ALL SIGNATURES COMPLETED

DocuSigned by:
SALPH 2/16/2022

00895	SIGNAL NO.	10-1846	PREPARED BY	9/2021	DATE
	NCDOT ID NO.				

SHEET **SIG2.1** OF **SIG2.8**

BROOKSHIRE BLVD. @ I-485 OUTER RAMP

TEMPORARY 1 SIGNAL PLAN

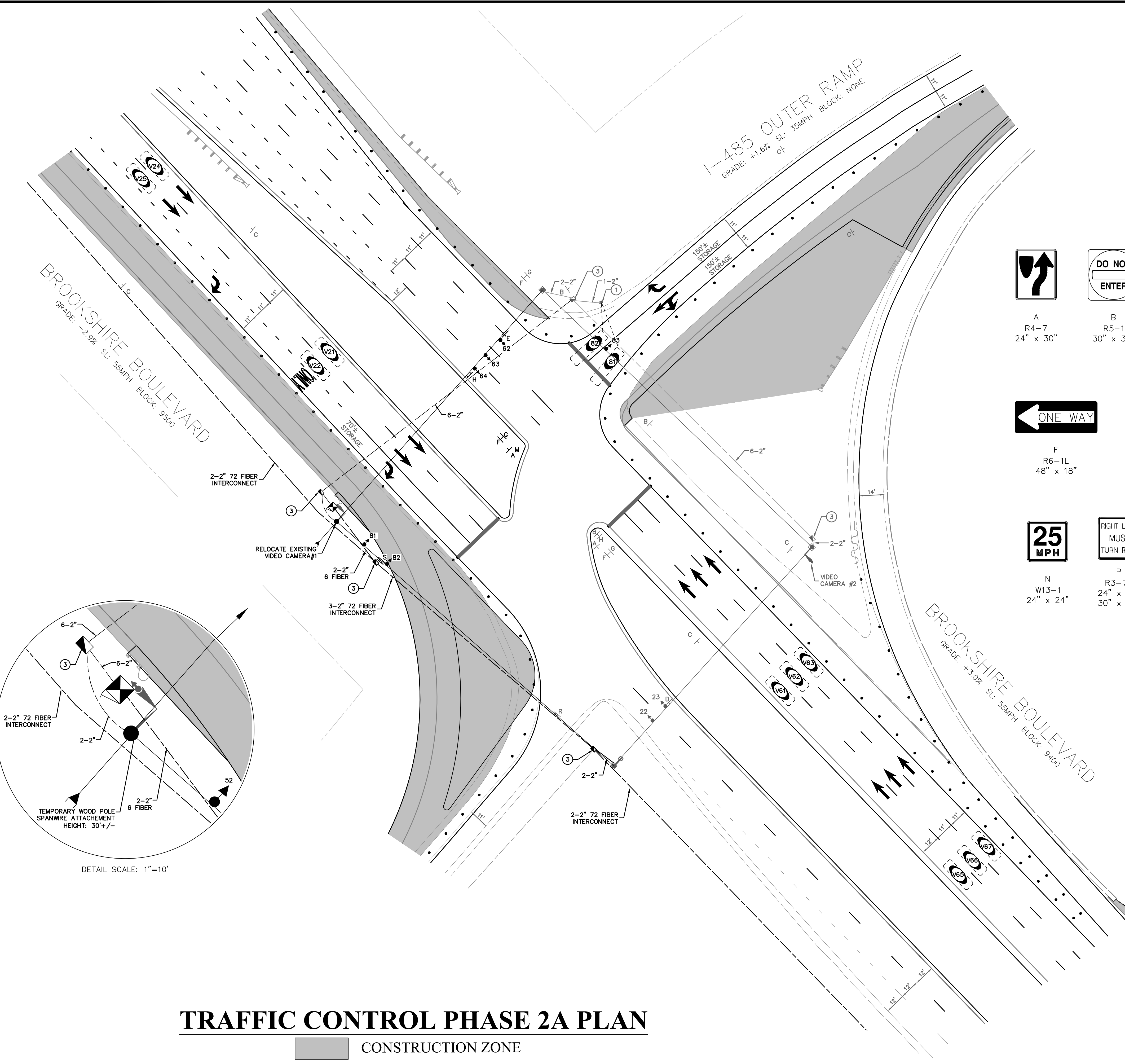

- SIGNAL HEAD ID**
- 82
 - 22,23
81,83
 - 62,63,64
- SIGN ID**
- A R4-7 24" x 30"
 - B R5-1 30" x 30"
 - C R5-1a 36" x 24"
 - D R3-2 24" x 24" 30" x 30"
 - E R3-1 24" x 24" 30" x 30"
 - F R6-1L 48" x 18"
 - G R6-1R 48" x 18"
 - H R3-18 24" x 24" 30" x 30"
 - M R3-7L 24" x 24" 30" x 30"
 - N W13-1 24" x 24"
 - P R3-7R 24" x 24" 30" x 30"
- LEGEND**
- BROOKSHIRE BLVD. 9400 R
 - BROOKSHIRE BLVD. 9500 S

TRAFFIC CONTROL PHASE 2A PLAN

CONSTRUCTION ZONE

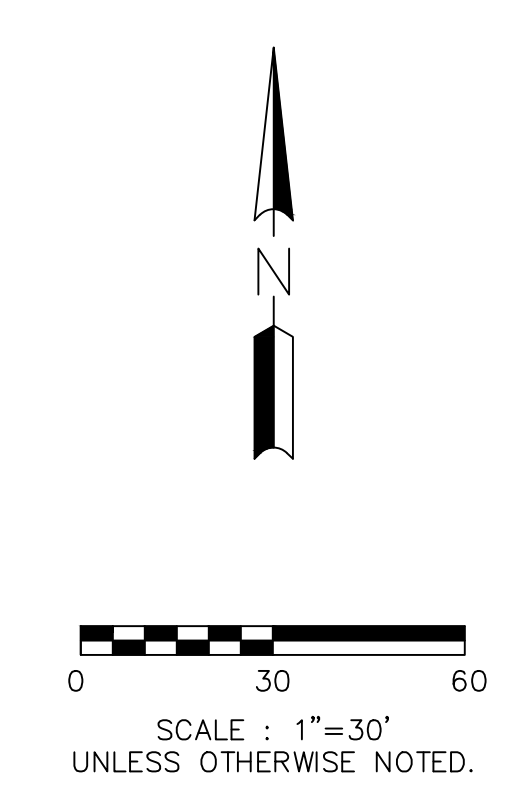

SIGNAL PHASING

Ring Configuration 1,2,3,4b
5,6,7,8b

1 NOT USED	5 NOT USED
2	6
3 NOT USED	7 NOT USED
4 NOT USED	8

MIN RECALL MIN RECALL

SIGNAL SEQUENCE

RING 1	PHASE 1	PHASE 2	PHASE 3	PHASE 4	FLASH
SIGNAL ID NUMBER	R/W OTH	R/W OTH	R/W OTH	R/W OTH	Y
22,23		G Y			

RING 2	PHASE 5	PHASE 6	PHASE 7	PHASE 8	FLASH
SIGNAL ID NUMBER	R/W OTH	R/W OTH	R/W OTH	R/W OTH	Y
62,63,64		▲ Y			
81,83				G Y R	
82				◀ Y R	

OVERLAP PHASE

OVERLAP PHASE	OL-A/-/+	OL-B/-/+	OL-C/-/+	OL-D/-/+	FLASH
SIGNAL ID NUMBER	R/W OTH	R/W OTH	R/W OTH	R/W OTH	Y

◀ RED ARROW ◀ YELLOW ARROW
◀ GREEN ARROW ✱ FLASHING YELLOW ARROW

TURNING MOVEMENT COUNT

Phase	1	2	3	4	5	6	7	8
% Grade	0.0%	-2.9%	0.0%	0.0%	0.0%	3.0%	0.0%	1.6%
Distance		35				95		110
Approach Speed (mph)		55				55		20
Yellow		5.5				4.9		3.0
All Red		1.0				1.2		3.4
Total Clearance		6.5				6.1		6.4

SIGN ID

A R4-7 24" x 30"
B R5-1 30" x 30"
C R5-1a 36" x 24"
D R3-2 24" x 24" 30" x 30"
E R3-1 24" x 24" 30" x 30"
F R6-1L 48" x 18"
G R6-1R 48" x 18"
H R3-18 24" x 24" 30" x 30"
M R3-7L 24" x 24" 30" x 30"
N W13-1 24" x 24"
P R3-7R 24" x 24" 30" x 30"

WRONG WAY
ONE WAY
BROOKSHIRE BLVD. 9400 R
BROOKSHIRE BLVD. 9500 S
LEFT LANE MUST TURN LEFT
RIGHT LANE MUST TURN RIGHT
25 MPH

PROJECT REFERENCE NO. **I-5973**
SHEET NO. **SIG. 2.2**

Plans Prepared By: **Kimley»Horn**
421 FAYETTEVILLE STREET, SUITE 600
RALEIGH, NORTH CAROLINA, 27601
PHONE: 919-677-2600

NO.	DATE	BY	REVISION DESCRIPTION

MALFUNCTION MANAGEMENT UNIT / CONFLICT MONITOR

PROGRAMMING DETAIL

(program card and tables as shown)

FIELD CHECK ENABLE

CHANNEL NUMBER	ENABLE/DISABLE
1	DISABLE
2	ENABLE
3	DISABLE
4	DISABLE
5	DISABLE
6	ENABLE
7	DISABLE
8	ENABLE
9	DISABLE
10	DISABLE
11	DISABLE
12	DISABLE
13	DISABLE
14	DISABLE
15	DISABLE
16	DISABLE

ECONOLITE EOS-2070 SPECIAL MMU PROGRAMMING

(program controller as shown)

- From Main Menu select **1. CONFIGURATION**
- From CONFIGURATION Submenu select **1. CABINET**
- From PORT 1 (SDLC) Submenu select **4. MONITOR PROGRAMMING**

CAUTION!
Set intersection to Flash before attempting to enter or change any MMU programming data.
This programming and that of the MMU programming card must match exactly. If they do not, the intersection will be placed into Flash.

```
MMU PROGRAM [ MANUAL ]
CH 6 5 4 3 2 1 0 9 8 7 6 5 4 3 2
1 . . . . .
2 . . . . . X . . .
3 . . . . .
4 . . . . .
5 . . . . .
6 . . . . .
7 . . . . .
8 . . . . .
9 . . . . .
10 . . . . .
11 . . . . .
12 . . . . .
13 . . . . .
14 . . . . .
15 . . . . .
```

END PROGRAMMING

UNIT OPTIONS

OPTION	SETTING
RECURRENT PULSE	ON
WALK DISABLE	OFF
LOG C/W FAULTS	ON
EXTERN WATCHDOG	OFF
24V-2=12VDC	OFF
PGM CARD MEMORY	ON
LEDguard	ON
FORCE TYPE 16	OFF
TYPE12-SDLC	OFF
VM 3xDay Latch	ON

FLASHING YELLOW ARROW

CONFIG MODE	B
ENABLE CHANNEL PAIR, FYA	
CH 1-13	OFF
CH 3-14	OFF
CH 5-15	OFF
CH 7-16	OFF
RED/YEL INPUT ENABLE	
CH 1	OFF
CH 3	OFF
CH 5	OFF
CH 7	OFF
FLASH RATE FAULT	ON
FYA TRAP DETECT	ON

MMU PROGRAMMING NOTE
ENSURE YELLOW CHANGE PLUS RED CLEARANCE MONITORING IS ENABLED FOR ALL CHANNELS.

DETECTOR RACK SETUP

INSERT DETECTOR CARDS IN RACK ACCORDING TO THE DETAIL SHOWN BELOW. PARTICULAR DETECTOR CHANNELS WILL CALL PHASES INDICATED.

DET BIU #1	COMMUNICATIONS	SLOT	SLOT	SLOT	SLOT	DET BIU #2
NOT USED	NOT USED	EMPTY	EMPTY	EMPTY	EMPTY	

DETECTOR INFORMATION

DETECTOR NUMBER	AMP. NO.	SIZE / ZONE	AMP TYPE	DELAY	DISABLE	COMMENTS:
V21,V22	1	AD-130'	2	N		(THRU) (CAMERA #1)
V23,V24	2	AD-280'	2	N		(THRU) (CAMERA #1)
V61,V62,V63	3	AD-130'	6	N		(THRU) (CAMERA #2)
V64,V64,V65	4	AD-280'	6	N		(THRU) (CAMERA #2)
81	5	6'x25'	8	N		STOPBAR
82	5	6'x25'	8	N		STOPBAR

NOTE:
ALL STOPBAR LOOPS EXTEND 5' BEYOND THE STOPBAR UNLESS OTHERWISE NOTED.
ALL LOOPS RECEIVE THREE TURNS.

DocuSigned by: **SALPH** 2/16/2022
0C74A8E0008437

00895 SIGNAL NO. 10-1846 NCDOT ID NO. 9/2021 DATE

BROOKSHIRE BLVD. @ I-485 OUTER RAMP
TEMPORARY 1 SIGNAL DETAILS

SHEET **SIG2.2** OF **SIG2.8**

NO.	DATE	BY	REVISION DESCRIPTION

DOCUMENT NOT CONSIDERED FINAL UNLESS ALL SIGNATURES COMPLETED



Designed by: *SALP* 2/16/2022
0327ASBP00847

00895 SIGNAL NO.	SLP PREPARED BY	9/2021 DATE
10-1846 NCDOT ID NO.		

BROOKSHIRE BLVD. @ I-485 OUTER RAMP	TEMPORARY 2 SIGNAL PLAN
SHEET SIG2.3	OF SIG2.8

SIGNAL HEAD ID

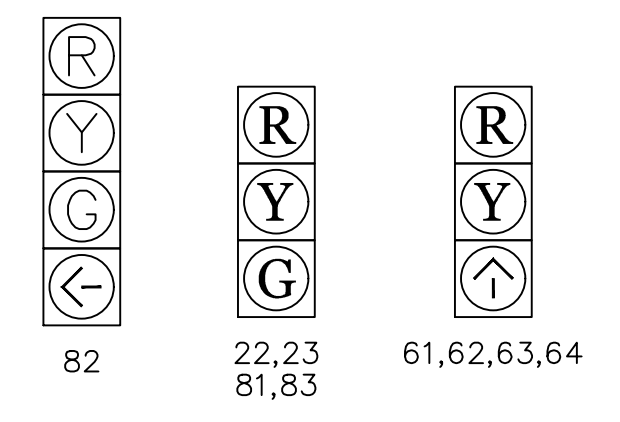

SIGN ID

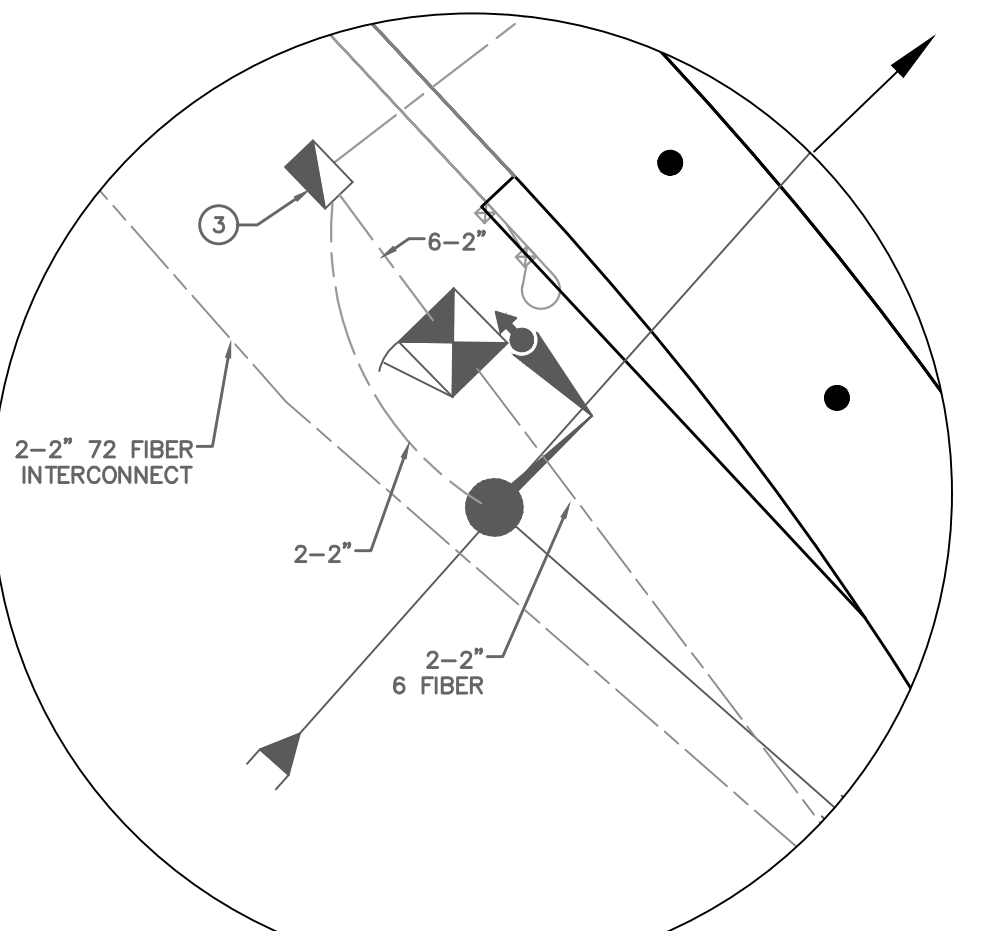
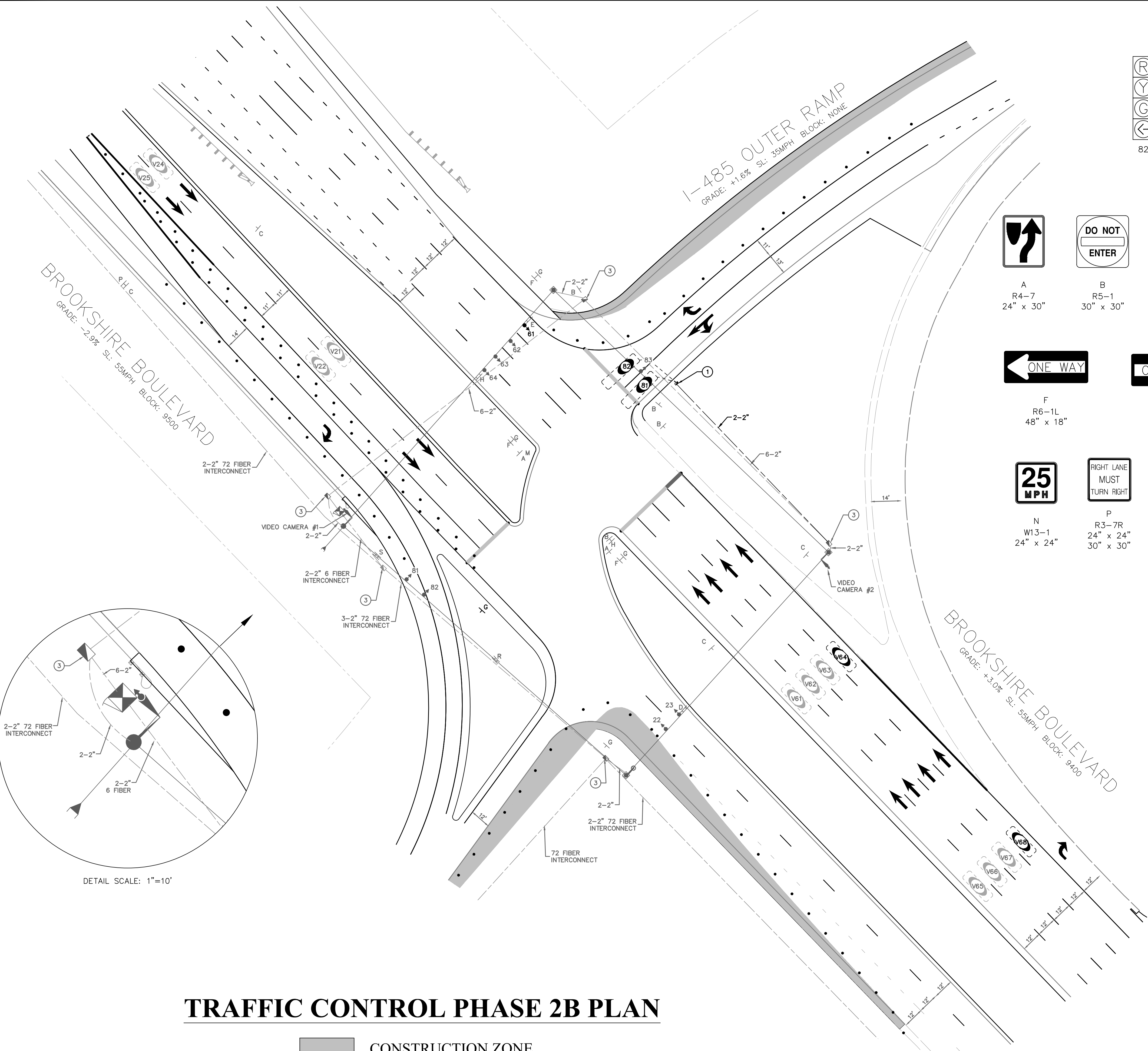
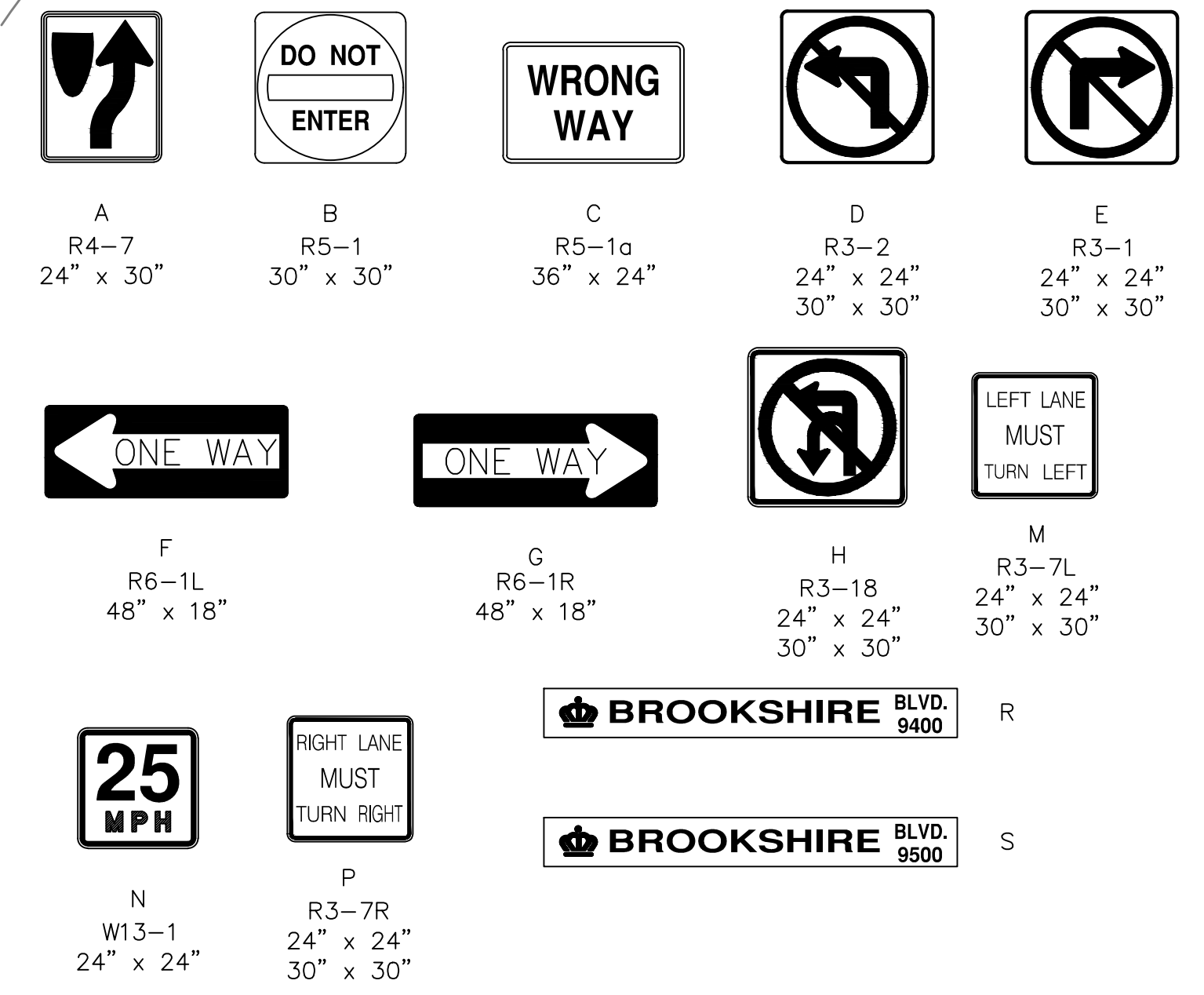

TRAFFIC CONTROL PHASE 2B PLAN

CONSTRUCTION ZONE

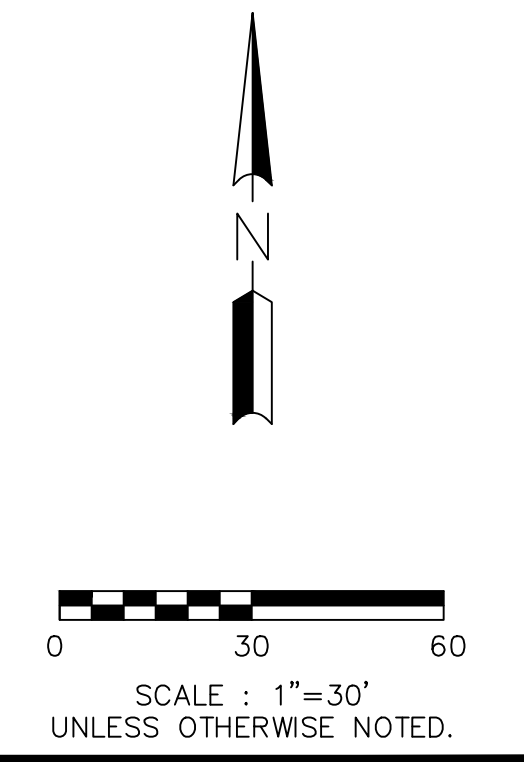

SIGNAL PHASING

Ring Configuration: 1, 2, 3, 4, 5, 6, 7, 8

1 NOT USED, 2, 3 NOT USED, 4 NOT USED, 5 NOT USED, 6, 7 NOT USED, 8

SIGNAL SEQUENCE

RING 1	PHASE 1	PHASE 2	PHASE 3	PHASE 4	FLASH
SIGNAL ID NUMBER	R/W	OTH	R/W	OTH	R/W
22,23		G	Y		

RING 2	PHASE 5	PHASE 6	PHASE 7	PHASE 8	FLASH
SIGNAL ID NUMBER	R/W	OTH	R/W	OTH	R/W
61,62,63,64		▲	Y		
81,83				G	Y
82				Y	R

OVERLAP PHASE

OL-A/-/+	OL-B/-/+	OL-C/-/+	OL-D/-/+	FLASH

RED ARROW < YELLOW ARROW
GREEN ARROW * FLASHING YELLOW ARROW

TURNING MOVEMENT COUNT

SIGNAL ID NUMBER	R/W	OTH	R/W	OTH	R/W	OTH	R/W	OTH	FLASH

SIGN ID

CLEARANCE INTERVALS

Phase	1	2	3	4	5	6	7	8
% Grade		-2.9%				3.0%		1.6%
Distance		35				80		100
Approach Speed (mph)		55				55		20
Yellow		5.5				4.9		3.0
All Red		1.0				1.0		3.3
Total Clearance		6.5				5.9		6.3

SIGNAL HEAD ID

MALFUNCTION MANAGEMENT UNIT / CONFLICT MONITOR

DETECTOR RACK SETUP

PROGRAMMING DETAIL

(program card and tables as shown)

FIELD CHECK ENABLE DUAL IND ENABLE RED FAIL ENABLE

CHANNEL NUMBER	ENABLE/DISABLE
1	DISABLE
2	ENABLE
3	DISABLE
4	DISABLE
5	DISABLE
6	ENABLE
7	DISABLE
8	ENABLE
9	DISABLE
10	DISABLE
11	DISABLE
12	DISABLE
13	DISABLE
14	DISABLE
15	DISABLE
16	DISABLE

CAUTION!

Set intersection to Flash before attempting to enter or change any MMU programming data. This programming and that of the MMU programming card must match exactly. If they do not, the intersection will be placed into Flash.

MMU PROGRAM [MANUAL]

CH	6	5	4	3	2	1	0	9	8	7	6	5	4	3	2
1
2	X
3
4
5
6
7
8
9
10
11
12
13
14
15

END PROGRAMMING

INSERT DETECTOR CARDS IN RACK ACCORDING TO THE DETAIL SHOWN BELOW. PARTICULAR DETECTOR CHANNELS WILL CALL PHASES INDICATED.

DET BIU #1	DETECTION	CH3 L7 NOT USED	CH1 L5 ∅ 8	COMMUNICATIONS	SLOT	SLOT	SLOT	SLOT	DET BIU #2
		CH4 L8 NOT USED	CH2 L6 ∅ 8		EMPTY	EMPTY	EMPTY	EMPTY	

DETECTOR INFORMATION

DETECTOR NUMBER	AMP. NO.	SIZE / ZONE	∅	AMP. TYPE	DELAY TYPE	COMMENTS:
V21,V22	1	AD-130'	2	N		(THRU) (CAMERA #1)
V23,V24	2	AD-280'	2	N		(THRU) (CAMERA #1)
V61,V62,V63,V64	3	AD-130'	6	N		(THRU) (CAMERA #2)
V65,V66,V67,V68	4	AD-280'	6	N		(THRU) (CAMERA #2)
81	5	6'x25'	8	N		STOPBAR
82	5	6'x25'	8	N		STOPBAR

NOTE: ALL STOPBAR LOOPS EXTEND 5' BEYOND THE STOPBAR UNLESS OTHERWISE NOTED. ALL LOOPS RECEIVE THREE TURNS.

PROJECT REFERENCE NO. **I-5973**
SHEET NO. **SIG. 2.4**

Plans Prepared By: **Kimley-Horn**
421 FAYETTEVILLE STREET, SUITE 600
RALEIGH, NORTH CAROLINA, 27601
PHONE 919-977-2000

NO.	DATE	BY	REVISION DESCRIPTION

DocuSigned by: **J.P. 2/16/2022**
0087A562D0B437

00895 SIGNAL NO. **BROOKSHIRE BLVD. @ I-485 OUTER RAMP**
10-1846 NCDOT ID NO. **TEMPORARY 2 SIGNAL DETAILS**

SHEET **SIG2.4** OF **SIG2.8**

PROJECT REFERENCE NO. **I-5973**

SHEET NO. **SIG. 2.5**

Plans Prepared By: **Kimley»Horn**
 421 FAYETTEVILLE STREET, SUITE 600
 RALEIGH, NORTH CAROLINA, 27601
 PHONE: 919-677-2000

NO.	DATE	BY	REVISION DESCRIPTION

DocuSigned by: *[Signature]* 2/16/2022
 0087A56E9D90B437

00895 SIGNAL NO.	10-1846 NCDOT ID NO.	9/2021 DATE
---------------------	-------------------------	----------------

BROOKSHIRE BLVD. @ I-485 OUTER RAMP
FINAL DESIGN SIGNAL PLAN

SHEET **SIG2.5** OF **SIG2.8**

SIGNAL HEAD ID

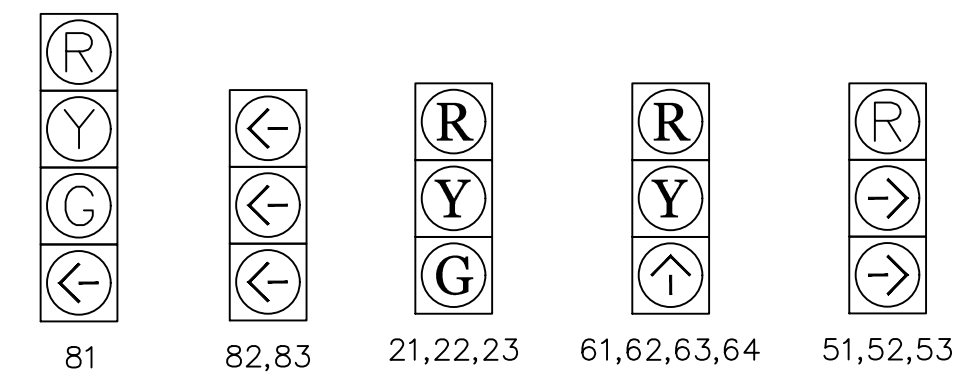

SIGN ID

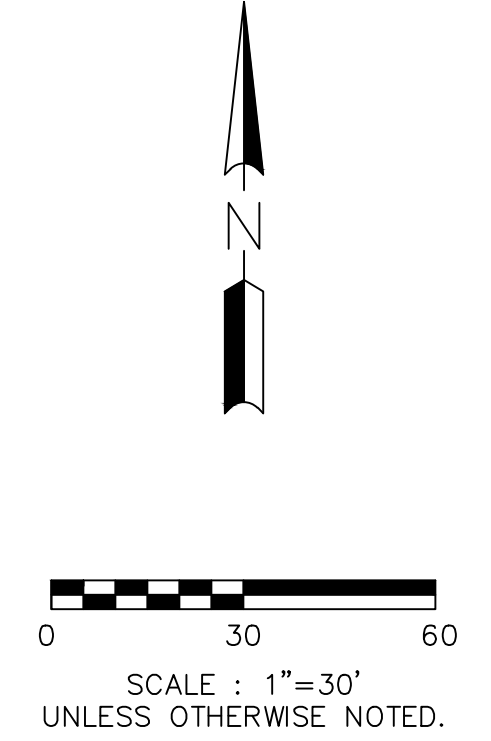
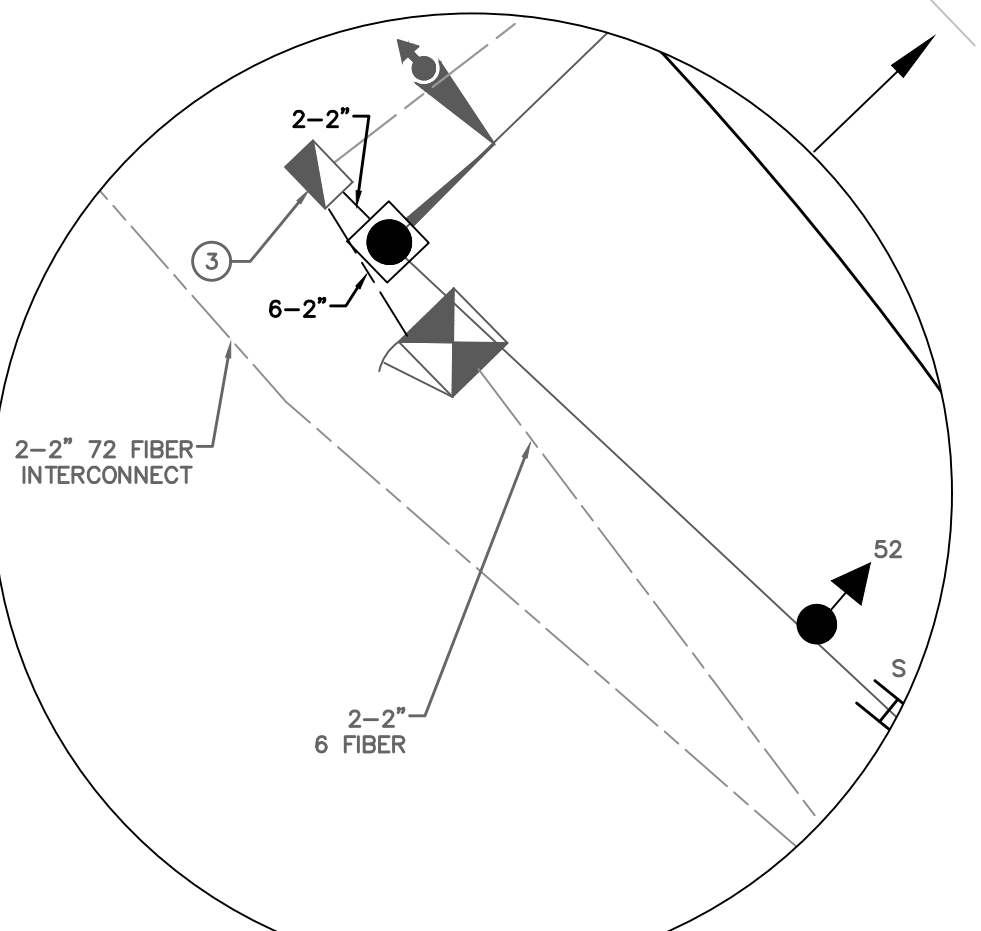
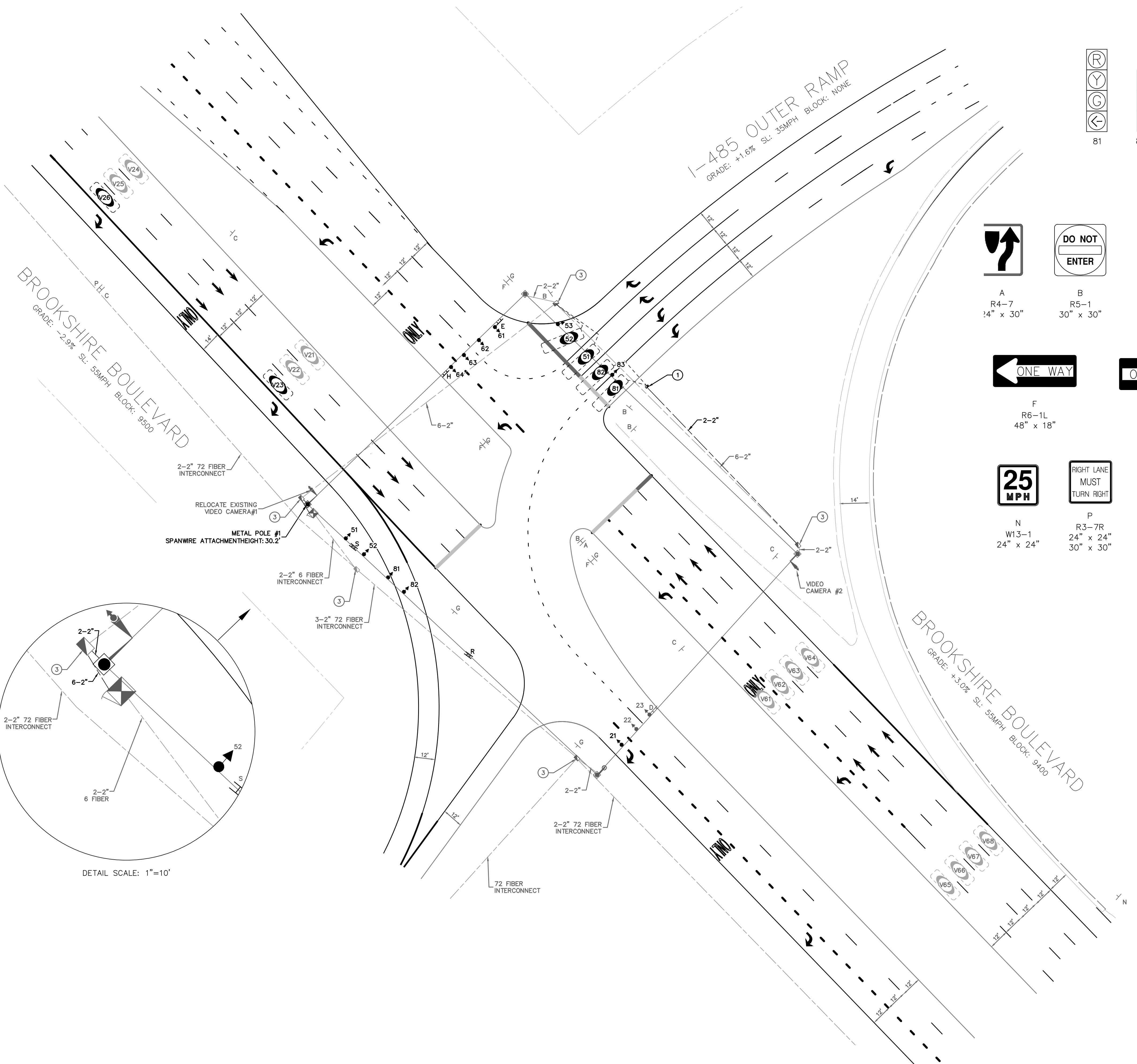
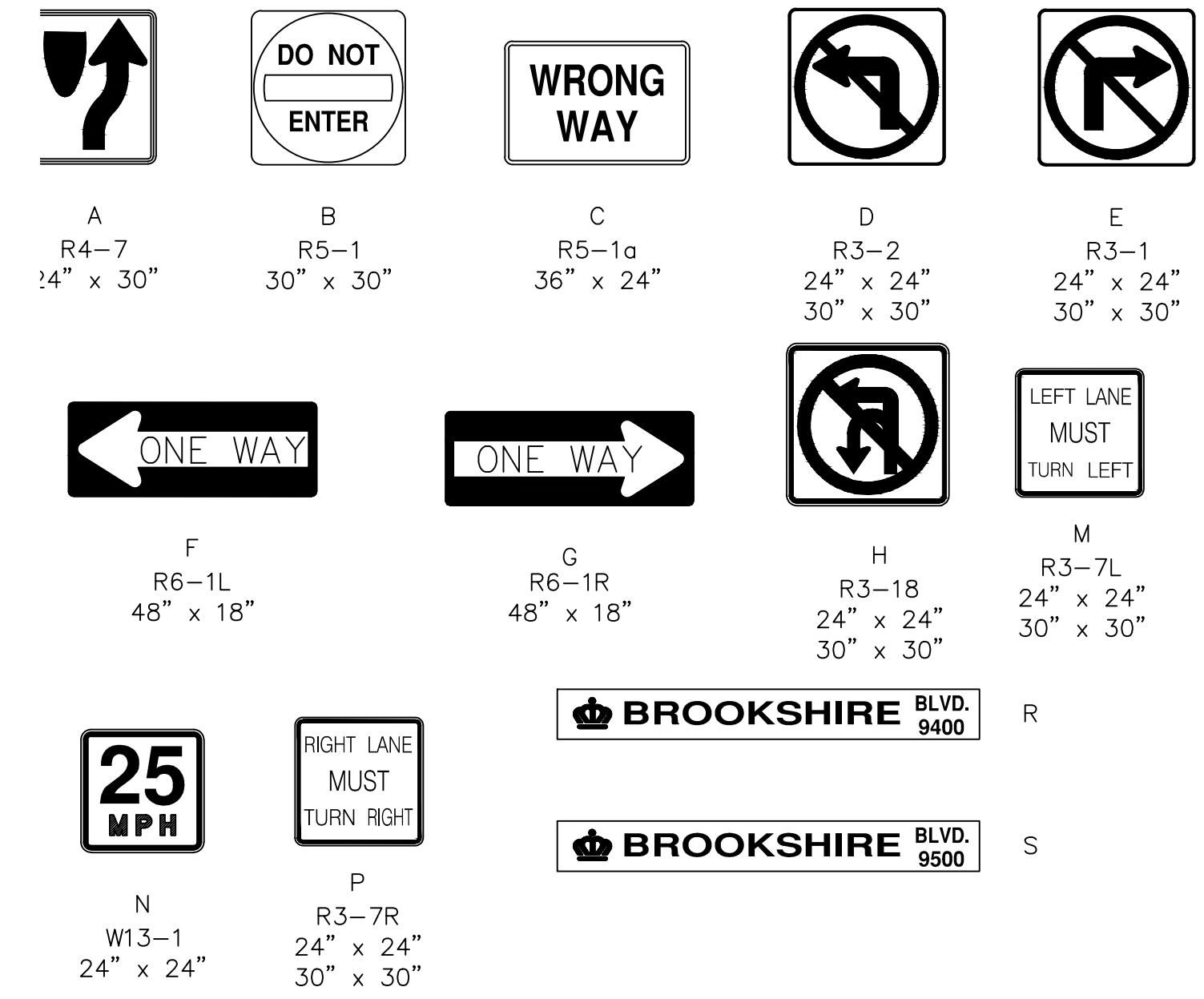

SIGNAL PHASING

Ring Configuration 1,2,3,4,5,6,7,8

1 NOT USED	5 OL-A
2	6
3 NOT USED	7 NOT USED
4 NOT USED	8 OL-A

SIGNAL SEQUENCE

RING 1	PHASE 1	PHASE 2	PHASE 3	PHASE 4	FLASH				
SIGNAL ID NUMBER	R/W	OTH	R/W	OTH	R/W	OTH	R/W	OTH	FLASH
21,22,23		G	Y						Y

RING 2	PHASE 5	PHASE 6	PHASE 7	PHASE 8	FLASH				
SIGNAL ID NUMBER	R/W	OTH	R/W	OTH	R/W	OTH	R/W	OTH	FLASH
61,62,63,64		▲	Y						Y
81									Y
82,83									Y

OVERLAP PHASE

OL-A/5+8	OL-B/-+--	OL-C/-+--	OL-D/-+--	FLASH					
SIGNAL ID NUMBER	R/W	OTH	R/W	OTH	R/W	OTH	R/W	OTH	FLASH
51,52,53									R

RED ARROW < YELLOW ARROW
GREEN ARROW * FLASHING YELLOW ARROW

TURNING MOVEMENT COUNT

Phase	1	2	3	4	5	6	7	8
% Grade	0.0%	-2.9%	0.0%	0.0%	1.6%	3.0%	0.0%	1.6%
Distance		35			50	80		120
Approach Speed (mph)		55			35	55		20
Yellow		5.5			3.7	4.9		3.0
All Red		1.0			1.0	1.0		3.6
Total Clearance		6.5			4.7	5.9		6.6

SIGN ID

A R4-7 24" x 30"	B R5-1 30" x 30"	C R5-1a 36" x 24"	D R3-2 24" x 24" 30" x 30"	E R3-1 24" x 24" 30" x 30"
F R6-1L 48" x 18"	G R6-1R 48" x 18"	H R3-18 24" x 24" 30" x 30"	M R3-7L 24" x 24" 30" x 30"	
N W13-1 24" x 24"	P R3-7R 24" x 24" 30" x 30"			

DO NOT ENTER, WRONG WAY, ONE WAY, LEFT LANE MUST TURN LEFT, BROOKSHIRE BLVD. 9400, BROOKSHIRE BLVD. 9500, 25 MPH, RIGHT LANE MUST TURN RIGHT

CLEARANCE INTERVALS

Phase	1	2	3	4	5	6	7	8
% Grade	0.0%	-2.9%	0.0%	0.0%	1.6%	3.0%	0.0%	1.6%
Distance		35			50	80		120
Approach Speed (mph)		55			35	55		20
Yellow		5.5			3.7	4.9		3.0
All Red		1.0			1.0	1.0		3.6
Total Clearance		6.5			4.7	5.9		6.6

SIGNAL HEAD ID

81	82,83	21,22,23	61,62,63,64	51,52,53
----	-------	----------	-------------	----------

MALFUNCTION MANAGEMENT UNIT / CONFLICT MONITOR

DETECTOR RACK SETUP

PROGRAMMING DETAIL

(program card and tables as shown)

FIELD CHECK ENABLE
DUAL IND ENABLE
RED FAIL ENABLE

CHANNEL NUMBER	ENABLE/DISABLE
1	DISABLE
2	ENABLE
3	DISABLE
4	DISABLE
5	ENABLE
6	DISABLE
7	DISABLE
8	ENABLE
9	DISABLE
10	DISABLE
11	DISABLE
12	DISABLE
13	ENABLE
14	DISABLE
15	DISABLE
16	DISABLE

ECONOLITE EOS-2070 SPECIAL MMU PROGRAMMING

(program controller as shown)

- From Main Menu select **1. CONFIGURATION**
- From CONFIGURATION Submenu select **1. CABINET**
- From PORT 1 (SDLC) Submenu select **4. MONITOR PROGRAMMING**

CAUTION!
Set intersection to Flash before attempting to enter or change any MMU programming data.
This programming and that of the MMU programming card must match exactly. If they do not, the intersection will be placed into Flash.

```

MMU PROGRAM [ MANUAL ]

CH 6 5 4 3 2 1 0 9 8 7 6 5 4 3 2
1 . . . . .
2 . . . X . . . . . X X . .
3 . . . . .
4 . . . . .
5 . . . X . . . . .
6 . . . . .
7 . . . . .
8 . . . X . . . . .
9 . . . . .
10 . . . . .
11 . . . . .
12 . . . . .
13 . . . . .
14 . . . . .
15 . . . . .
    
```

END PROGRAMMING

OPTION	SETTING
RECURRENT PULSE	ON
WALK DISABLE	OFF
LOG CVM FAULTS	ON
EXTERN WATCHDOG	OFF
24V-2=12VDC	OFF
PGM CARD MEMORY	ON
LEDguard	ON
FORCE TYPE 16	OFF
TYPE12-SDLC	OFF
VM 3xDay Latch	ON

CONFIG MODE	B
ENABLE CHANNEL PAIR, FYA	
CH 1-13	OFF
CH 3-14	OFF
CH 5-15	OFF
CH 7-16	OFF
RED/YEL INPUT ENABLE	
CH 1	OFF
CH 3	OFF
CH 5	OFF
CH 7	OFF
FLASH RATE FAULT	ON
FYA TRAP DETECT	ON

MMU PROGRAMMING NOTE
ENSURE YELLOW CHANGE PLUS RED CLEARANCE MONITORING IS ENABLED FOR ALL CHANNELS.

INSERT DETECTOR CARDS IN RACK ACCORDING TO THE DETAIL SHOWN BELOW. PARTICULAR DETECTOR CHANNELS WILL CALL PHASES INDICATED.

DET BIU #1	DETECTION	CH3	CH1	COMMUNICATIVE REMOTE	SLOT	SLOT	SLOT	SLOT	DET BIU #2
		L7	L5		EMPTY	EMPTY	EMPTY	EMPTY	
		Ø 5	Ø 8						
		L8	L6						
		Ø 5	Ø 8						

DETECTOR INFORMATION

DETECTOR NUMBER	AMP. NO.	SIZE / ZONE	Ø	AMP. DELAY TYPE	DISABLE	COMMENTS:
V21,V22,V23	1	AD-130'	2	N		(THRU) (CAMERA #1)
V24,V25,V26	2	AD-280'	2	N		(THRU) (CAMERA #1)
V61,V62,V63,V64	3	AD-130'	6	N		(THRU) (CAMERA #2)
V65,V66,V67,V68	4	AD-280'	6	N		(THRU) (CAMERA #2)
81	5	6'x25'	8	N		STOPBAR
82	5	6'x25'	8	N		STOPBAR
51	6	6'x25'	5	D	5,8	STOPBAR
52	6	6'x25'	5	D	5,8	STOPBAR

NOTE:
ALL STOPBAR LOOPS EXTEND 5' BEYOND THE STOPBAR UNLESS OTHERWISE NOTED.
ALL LOOPS RECEIVE THREE TURNS.

00895 SIGNAL NO. 10-1846 NCDOT ID NO. 9/2021 DATE

BROOKSHIRE BLVD. @ I-485 OUTER RAMP
SHEET SIG2.6 OF SIG2.8
FINAL DESIGN SIGNAL DETAILS

PROJECT REFERENCE NO. **I-5973**
SHEET NO. **SIG. 2.6**

Plans Prepared By: **Kimley»Horn**
421 FAYETTEVILLE STREET, SUITE 600
RALEIGH, NORTH CAROLINA, 27601
PHONE: 919-677-2000

REVISION DESCRIPTION
NO. DATE BY

DocuSigned by: **SAW** 2/16/2022
0087AS96068497

**NEW SPLICE ENCLOSURE IN NEW HANDHOLE (HH5) AT
BROOKSHIRE BLVD AT I-485 SB OUTER RAMP
SIG. INV# 00895 (10-1846)**

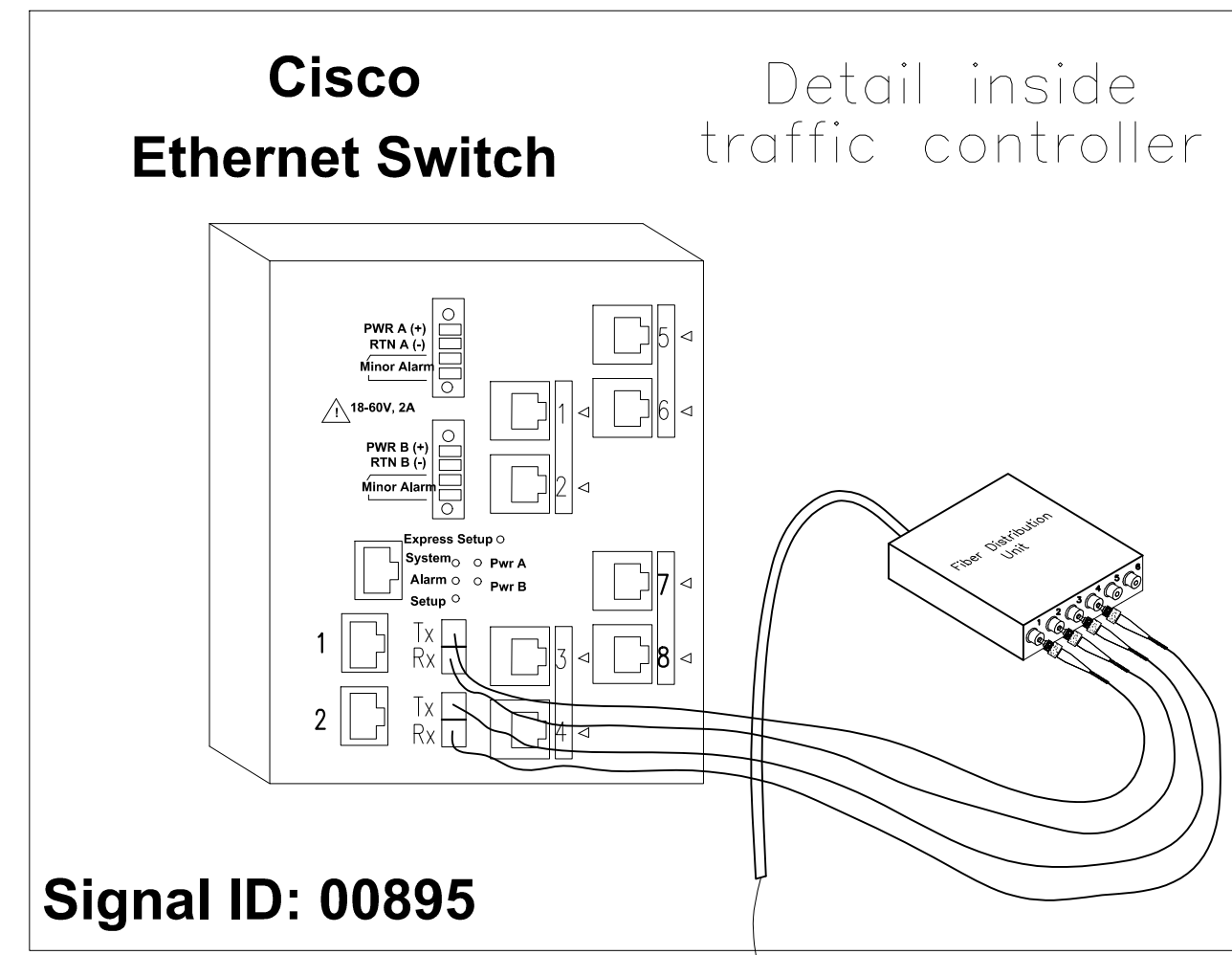

COLOR CODE TIA/EIA 598-A		LEGEND	
(1) BLUE	(7) RED	○ EXISTING SPLICE	□ BUFFER TUBE
(2) ORANGE	(8) BLACK	● NEW SPLICE	
(3) GREEN	(9) YELLOW		
(4) BROWN	(10) VIOLET		
(5) SLATE	(11) ROSE		
(6) WHITE	(12) AQUA		

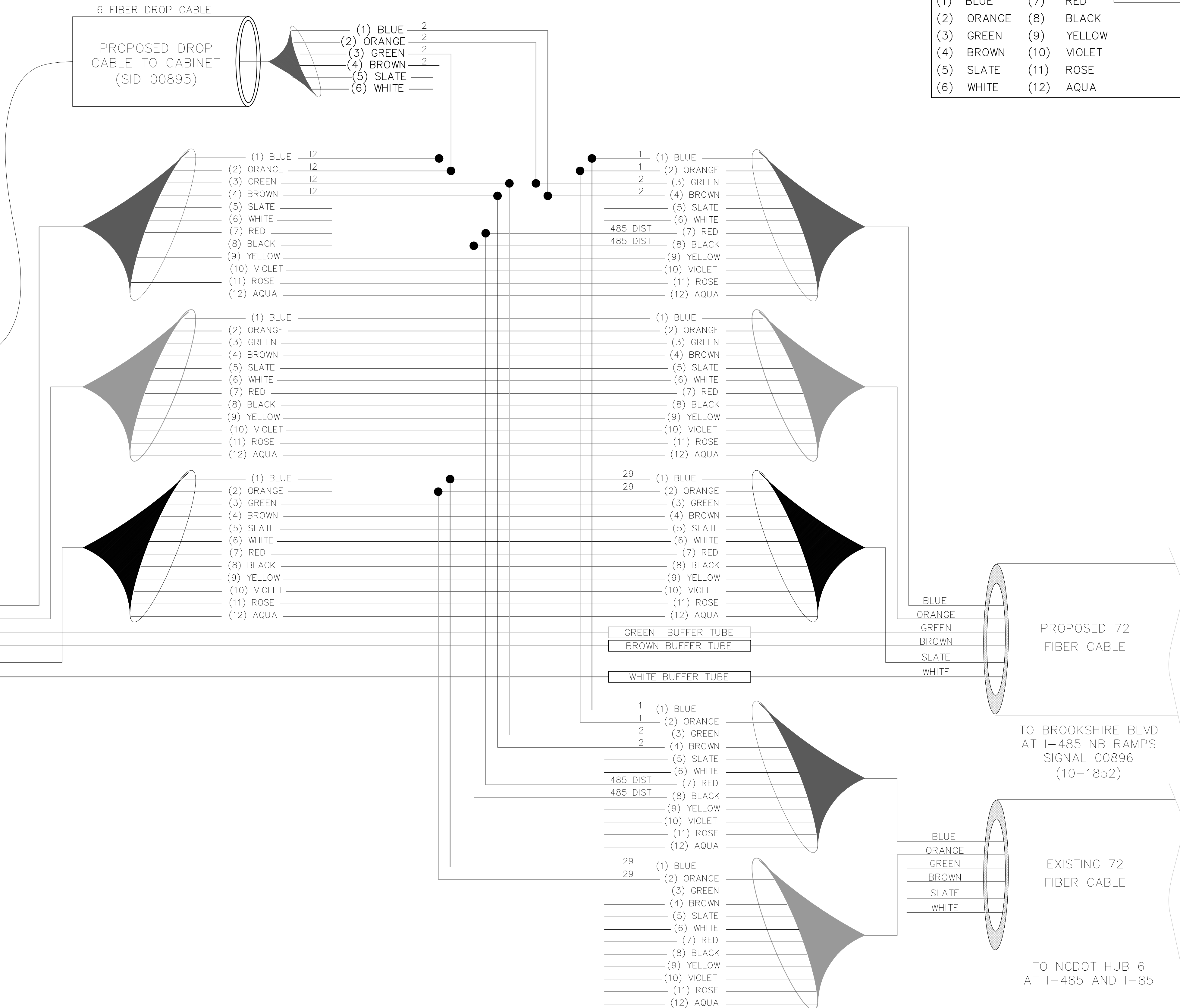

PROJECT REFERENCE NO. **I-5973**
SHEET NO. **SIG. 2.7**

Plans Prepared By: **Kimley-Horn**
421 FAYETTEVILLE STREET, SUITE 600
RALEIGH, NORTH CAROLINA, 27601
PHONE: 919-971-6000

NO.	DATE	BY	DESCRIPTION

DOCUMENT NOT CONSIDERED FINAL UNLESS ALL SIGNATURES COMPLETED

DocuSigned by: *SAH/PA* 2/16/2022
0087458E0000437

00895 SIGNAL NO.	10-1846 NCDOT ID NO.	SLP PREPARED BY	9/2021 DATE
---------------------	-------------------------	--------------------	----------------

BROOKSHIRE BLVD. @ I-485 OUTER RAMP
SHEET **SIG. 2.7** OF **SIG. 2.8**
SPLICE DETAIL

SPLICE CASE IN FIBER HH# 5 (SEE SHEET CR7) AT BROOKSHIRE BLVD

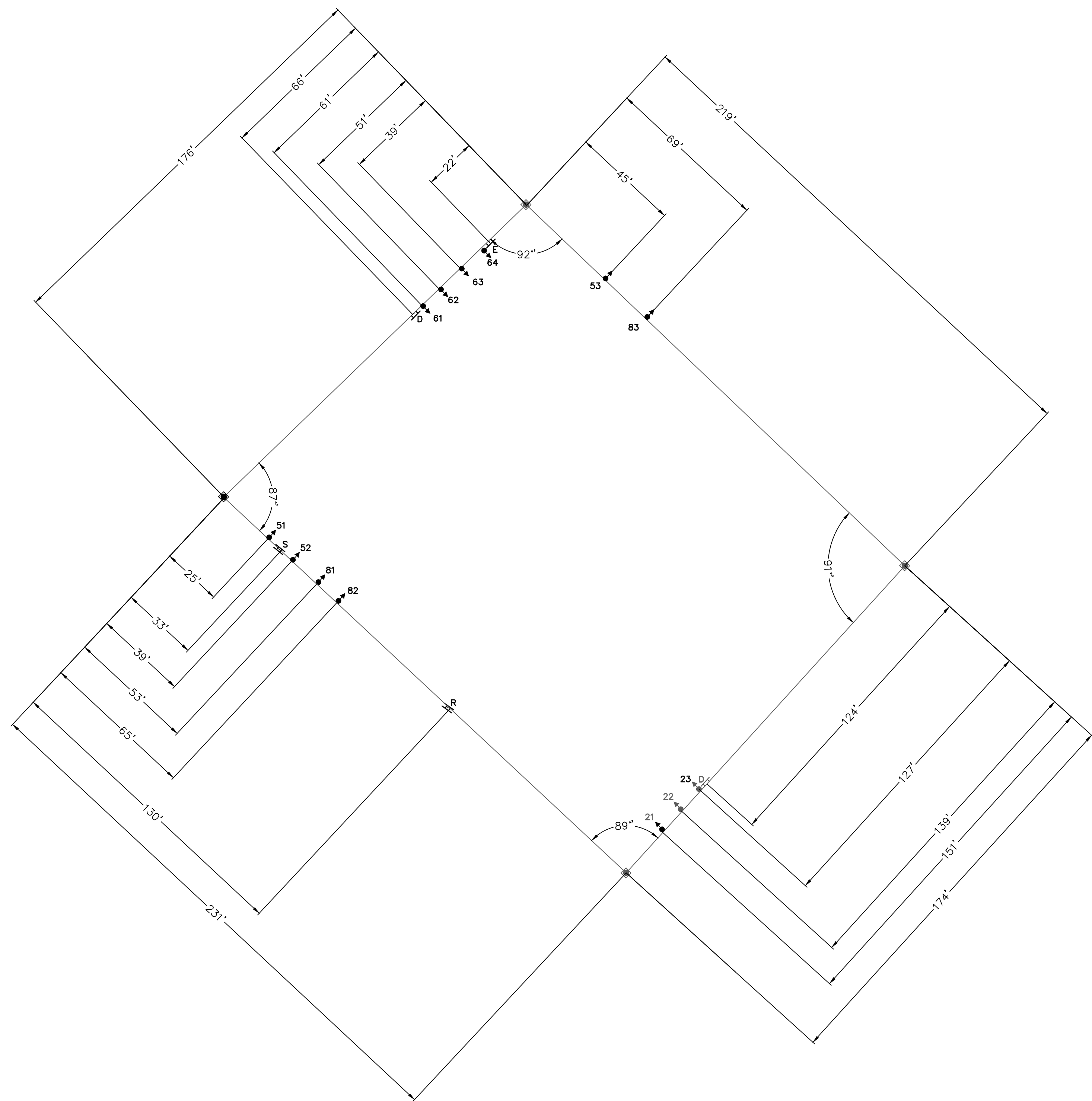

METAL STRAIN POLE LOADING SCHEDULE				
LOADING SYMBOL	DESCRIPTION	AREA	SIZE	WEIGHT
	SIGNAL HEAD 12"-4 SECTION-WITH HANGER AND BALANCE ADJUSTER	16.3 S.F.	25.5" W X 66.0" L	69 LBS
	SIGNAL HEAD 12"-3 SECTION-WITH HANGER AND BALANCE ADJUSTER	9.3 S.F.	25.5" W X 52.5" L	56 LBS
	SIGN WITH HANGER AND BALANCE ADJUSTER	5.0 S.F.	24.0" W X 30.0" L	11 LBS
	STREET NAME SIGN WITH HANGER AND BALANCE ADJUSTER	12.0 S.F.	18.0" W X 96.0" L	27 LBS

SIGNAL HEAD ID

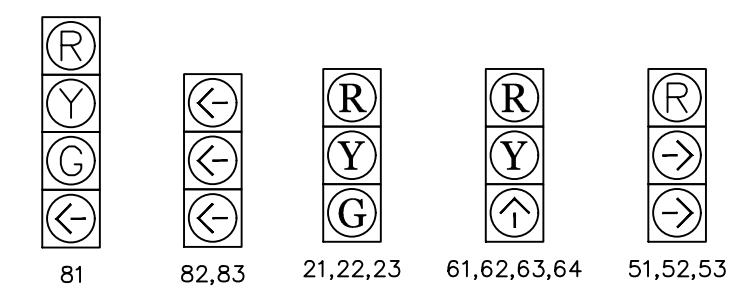

SIGN ID

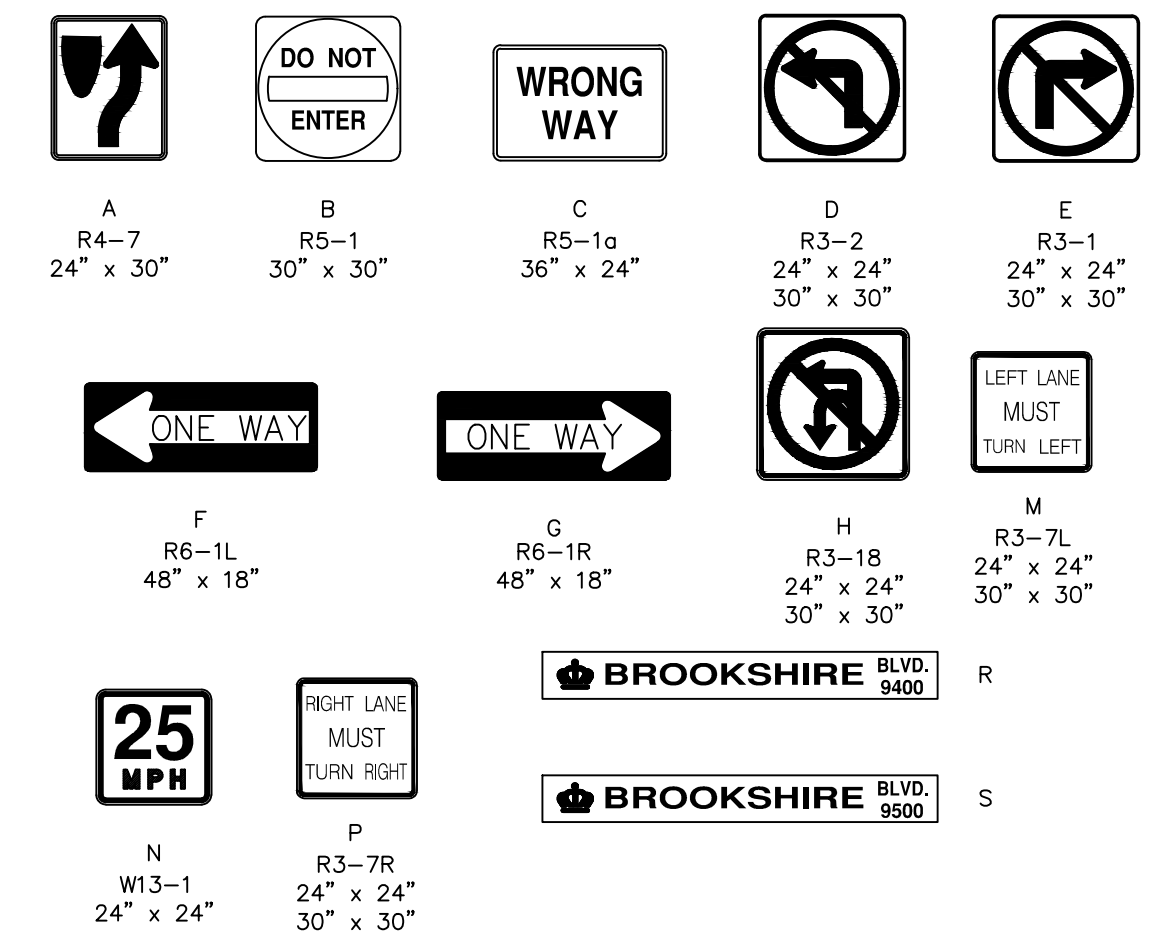

PROJECT REFERENCE NO. **I-5973**

SHEET NO. **SIG. 2.8**

Plans Prepared By: **Kimley»Horn**
421 FAVETTEVALE STREET, SUITE 600
RALEIGH, NORTH CAROLINA, 27601
PHONE: 919-677-2000

NO.	DATE	BY	DESCRIPTION

DOCUMENT NOT CONSIDERED FINAL UNTIL SIGNATURES COMPLETED

DocuSigned by: *SJH* 2/16/2022

00895 SIGNAL NO. 10-1846 NCDOT ID NO.

PREPARED BY: SLP 9/2021 DATE

BROOKSHIRE BLVD. @ I-485 OUTER RAMP

METAL POLE DETAILS

SHEET **SIG2.8** OF **SIG2.8**

TIP PROJECT: I-5973

CONTRACT: C204658

INDEX OF SHEETS	
Cover Sheet.....	SIG3.0
Temp Signal Plans	SIG3.1-SIG3.2
Temp Signal Details	SIG3.3
Final Signal Plans	SIG3.4
Final Signal Details	SIG3.5
Final Splice Detail	SIG3.6
TOTAL SHEETS 7	



Signal Plans of
BROOKSHIRE BLVD. @ I-485 INNER RAMP
 CDOT Signal ID 00896
 NCDOT 10-1853

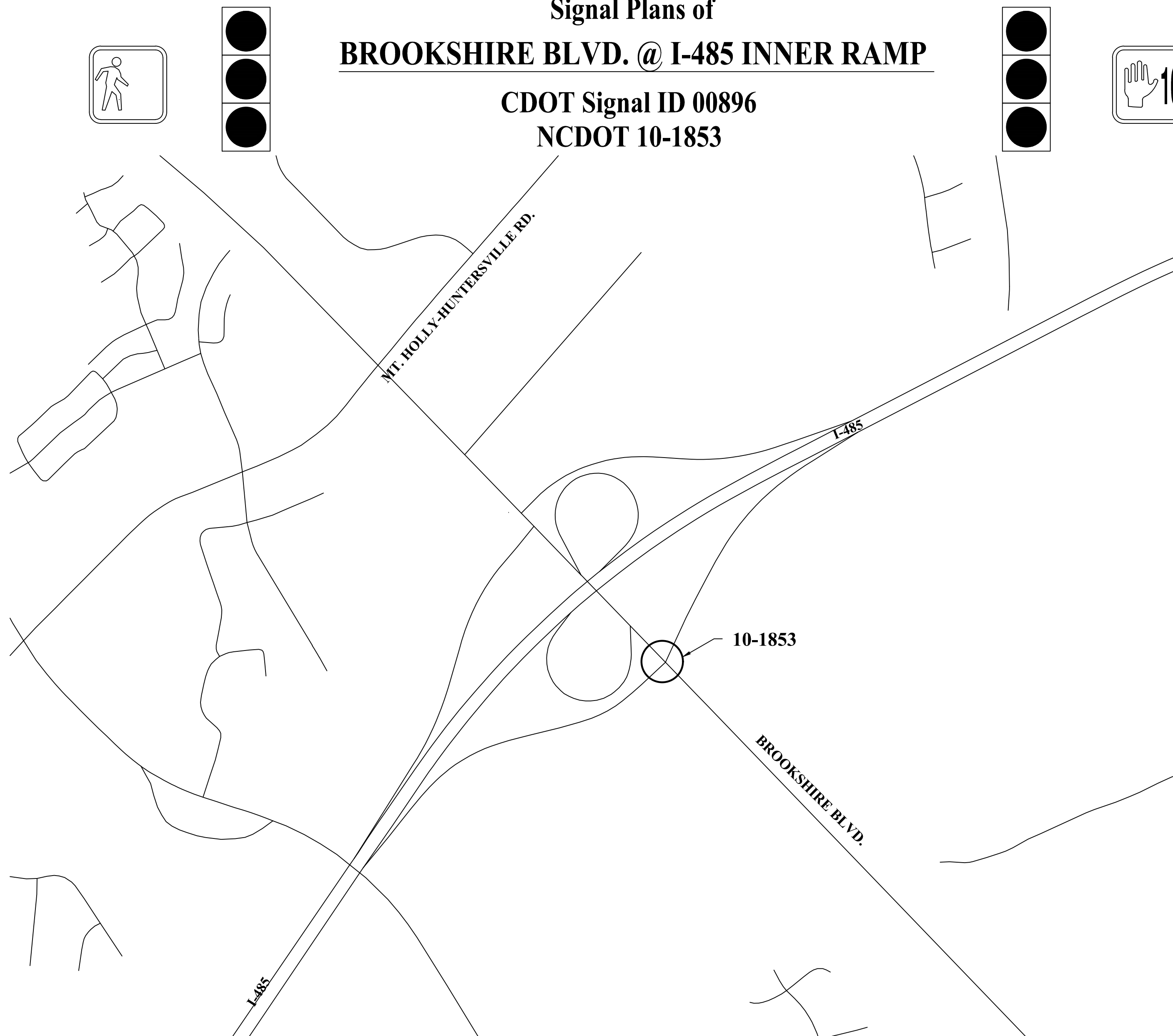

VICINITY MAP (NTS)

DOCUMENT NOT CONSIDERED FINAL UNLESS ALL SIGNATURES COMPLETED

PLANS PREPARED BY:

Kimley»Horn

421 FAYETTEVILLE STREET, SUITE 600
 RALEIGH, NORTH CAROLINA, 27601
 PHONE: 919-677-2000

PLAN NOTES

1. ALL PAVEMENT MARKING DIMENSIONS ARE APPROXIMATE.
2. SIGNAL SHALL BE INSTALLED IN ACCORDANCE WITH THE LATEST NCDOT STANDARD SPECIFICATIONS AND CDOT TRAFFIC SIGNAL SPECIAL PROVISIONS.
3. PED SIGNALS WITH PUSHBUTTONS WILL BE LABELED "PB" (FOR EXAMPLE PB21, PB22)
4. COUNTDOWN PEDESTRIAN SIGNALS SHALL COUNT DOWN FLASHING DON'T WALK ONLY.

PE SEAL

DocuSigned by:
SL Phillips
 IC27A8B2ED08437

2/16/2022

PROJECT TEAM	
DESIGNER:	SP PENNINGTON
PROJECT MANAGER:	SL PHILLIPS, P.E.

SHEET 3.0

CHARLOTTE
TRANSPORTATION

PROJECT REFERENCE NO. I-5973
SHEET NO. SIG. 3.0

LEGEND		
PROPOSED	DESCRIPTION	EXISTING
	CONTROL BOX	
	METER PEDESTAL	
	PULL BOX	
	STEEL POLE	
	MAST ARM	
	PED PEDESTAL	
	UTILITY POLE	
	ANCHOR	
	SIGNAL HEAD	
	VIDEO CAMERA	
	OPTICOM	
	OBSERVATION CAM	
	DETECTOR	
	CONDUIT	
	INTERCONNECT	
	EDGE OF PVMT.	
	CURB & GUTTER	
	TUBULAR MARKER	
	GROUND SIGN	
	OVERHEAD SIGN	
	DOUBLE YELLOW	
	STOP BAR	
	WHITE SKIP	
	WHITE MINI	
	PAVEMENT ARROW	
	PROPERTY LINE	
	ROW	

PULLBOX ID		
	SIZE	PULLBOX TYPE
①	13"x24"x12"	LOOP
②	17"x30"x24"	FIBER OPTIC
③	24"x36"x24"	CONTROLLER / FIBER
④	30"x48"x36"	CONTROLLER
⑤	24"x24"x12"	CONTROLLER
⑥	36"x36"x12"	CONTROLLER

NOTE:
 PULLBOX MATERIAL MUST MEET OR EXCEED THE 1998 CDOT TRAFFIC SIGNAL SPECIFICATIONS.

Signal ID 00896 / NCDOT 10-1853

BROOKSHIRE BLVD. @ I-485 INNER RAMP

TRAFFIC CONTROL PHASE 2A PLAN

CONSTRUCTION ZONE

CONSTRUCTION NOTES: BAG EXISTING SIGNAL HEAD #43

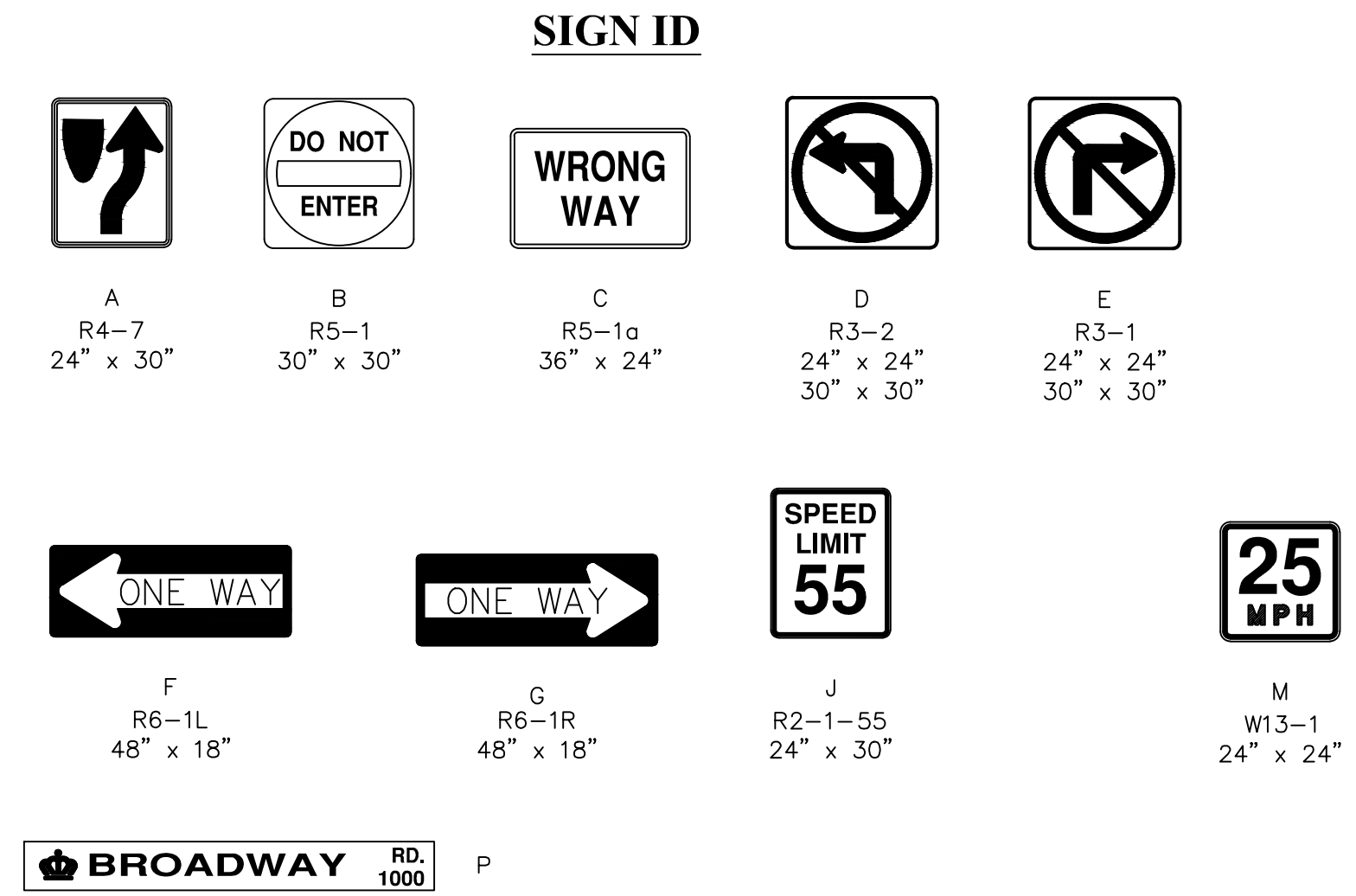
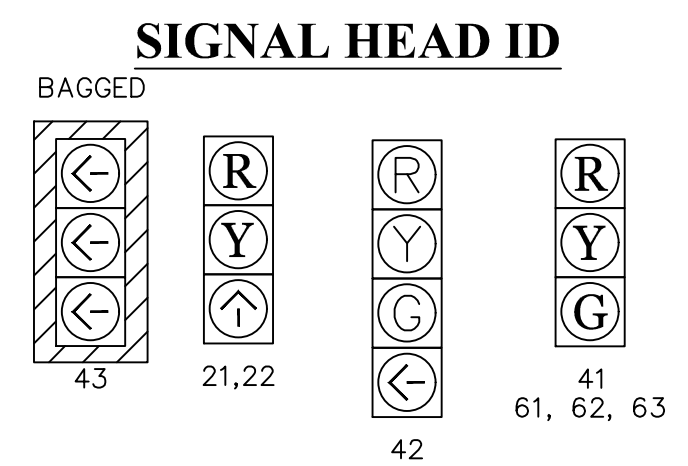
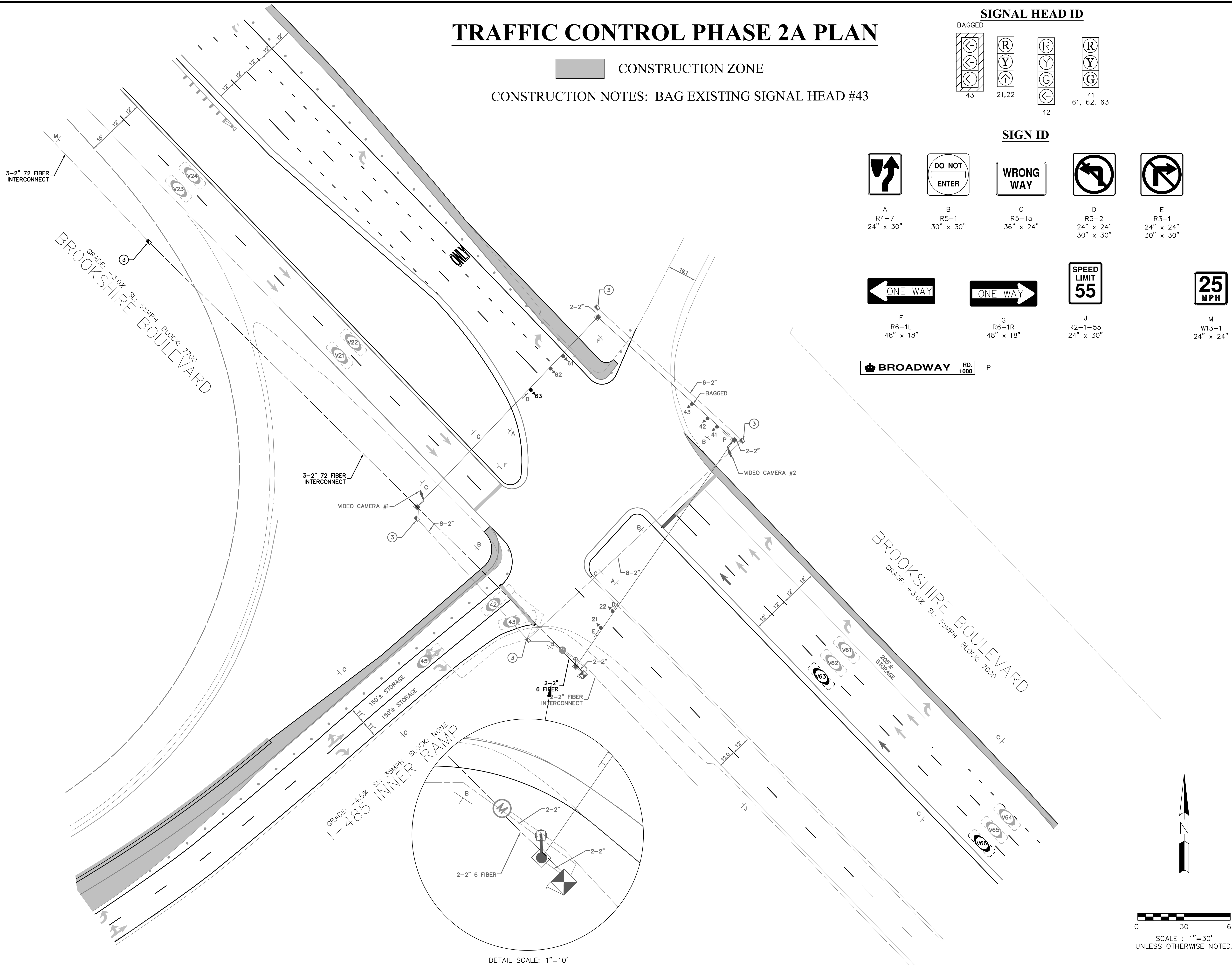

PROJECT REFERENCE NO.
I-5973
 SHEET NO.
SIG. 3.1

Plans Prepared By:
Kimley-Horn
 421 FAYETTEVILLE STREET, SUITE 600
 RICHMOND, VA 23220
 PHONE 819-677-2000

NO.	DATE	BY	REVISION DESCRIPTION



DocuSigned by:
 SALPH 2/16/2022
 (007A9E9D90847)

00896 SIGNAL NO.	10-1853 NCDOT ID NO.	SLP PREPARED BY	9/2021 DATE
---------------------	-------------------------	--------------------	----------------

SHEET
SIG3.1
 OF
SIG3.6

BROOKSHIRE BLVD. @ I-485 INNER RAMP
TEMPORARY 1 SIGNAL PLAN

DETAIL SCALE: 1"=10'

SCALE: 1"=30'
 UNLESS OTHERWISE NOTED.

TRAFFIC CONTROL PHASE 2B PLAN

CONSTRUCTION ZONE

CONSTRUCTION NOTES: BAG EXISTING SIGNAL HEAD #43

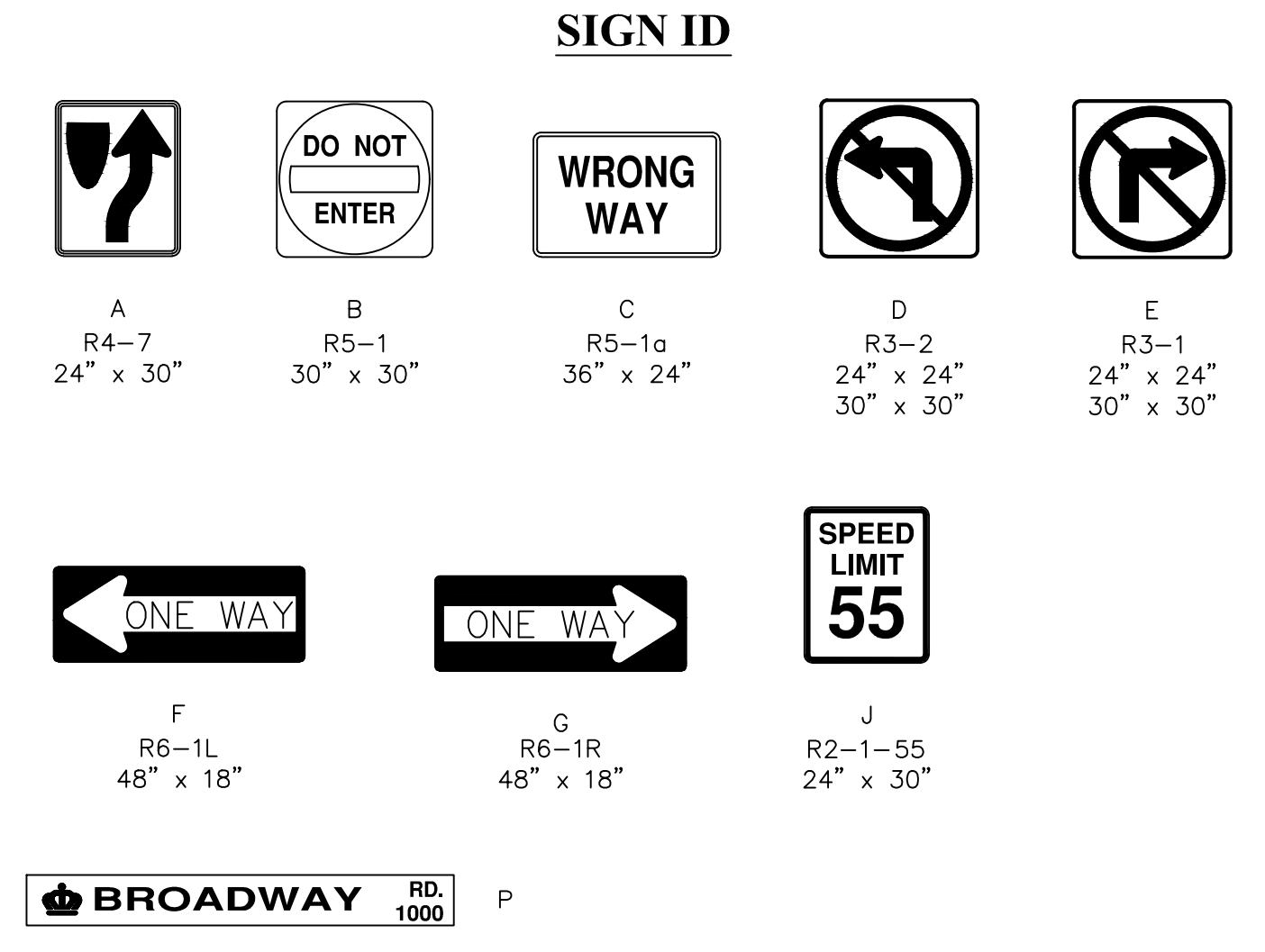
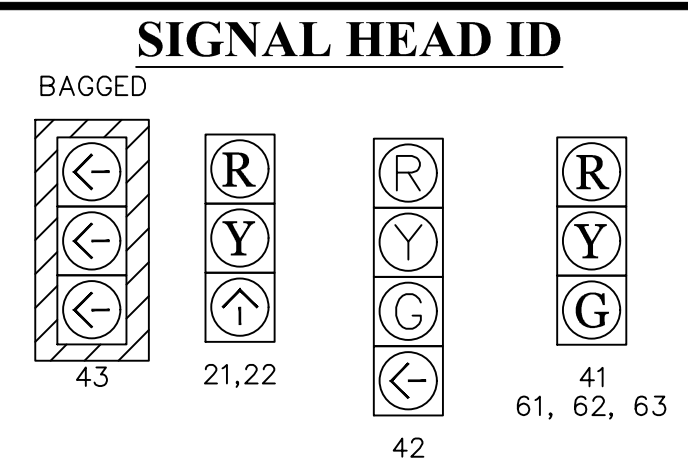
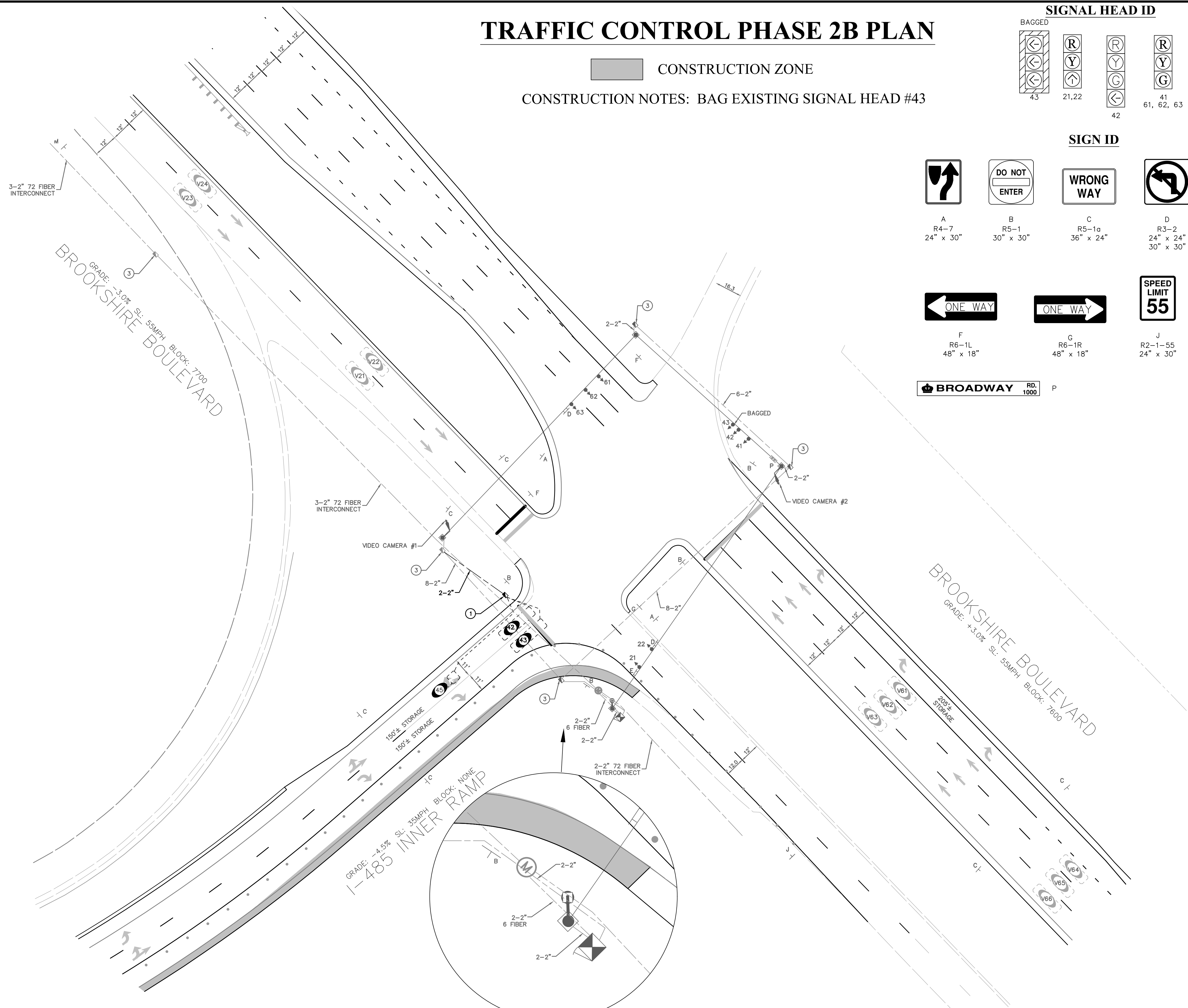

PROJECT REFERENCE NO.
I-5973

SHEET NO.
SIG. 3.2

Plans Prepared By:
Kimley»Horn
 421 FAYETTEVILLE STREET, SUITE 600
 RALEIGH, NORTH CAROLINA, 27601
 PHONE: 919-677-6000

NO.	DATE	BY	REVISION DESCRIPTION

DOCUMENT NOT CONSIDERED FINAL UNLESS SIGNED AND SEALED BY A LICENSED PROFESSIONAL ENGINEER

DocuSigned by:
SAL P. 2/16/2022
 DC87ASRE0006437

00896 SIGNAL NO.	SLP PREPARED BY	9/2021 DATE
10-1853 NCDOT ID NO.		

SHEET **SIG3.2** OF **SIG3.6**

BROOKSHIRE BLVD. @ I-485 INNER RAMP

TEMPORARY 2 SIGNAL PLAN

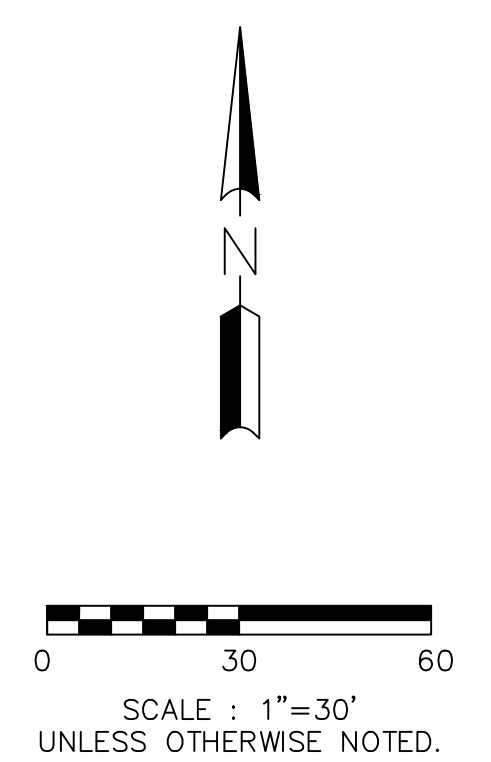

DETAIL SCALE: 1"=10'

SIGNAL PHASING

Ring Configuration 1, 2, 3, 4, 5, 6, 7, 8

1	NOT USED	5	NOT USED
2		6	
3	NOT USED	7	NOT USED
4		8	NOT USED

MIN RECALL MIN RECALL

SIGNAL SEQUENCE

RING 1	PHASE 1		PHASE 2		PHASE 3		PHASE 4		FLASH
SIGNAL ID NUMBER	R/W	OTH	R/W	OTH	R/W	OTH	R/W	OTH	
21,22			▲	Y			G	Y	R
41							G	Y	R
42							G	Y	R

RING 2	PHASE 5		PHASE 6		PHASE 7		PHASE 8		FLASH
SIGNAL ID NUMBER	R/W	OTH	R/W	OTH	R/W	OTH	R/W	OTH	
61,62,63			G	Y					Y

OVERLAP PHASE

OVERLAP PHASE	OL-A/--	OL-B/--	OL-C/--	OL-D/--	FLASH
SIGNAL ID NUMBER	R/W	OTH	R/W	OTH	

◀ RED ARROW ◁ YELLOW ARROW
 ◀ GREEN ARROW ✱ FLASHING YELLOW ARROW

TURNING MOVEMENT COUNT

CLEARANCE INTERVALS

Phase	1	2	3	4	5	6	7	8
% Grade	0.0%	-3.0%	0.0%	-4.5%	0.0%	3.0%	0.0%	0.0%
Distance		60		115		65		
Approach Speed (mph)		55		35		55		
Yellow		5.5		4.2		4.9		
All Red		1.0		2.5		1.0		
Total Clearance		6.5		6.7		5.9		

SIGN ID



 A
R4-7
24" x 30"

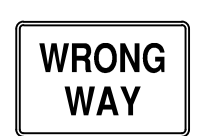

 B
R5-1
30" x 30"



 C
R5-1a
36" x 24"



 D
R3-2
24" x 24"
30" x 30"



 E
R3-1
24" x 24"
30" x 30"

 F
R6-1L
48" x 18"

 G
R6-1R
48" x 18"

 J
R2-1-55
24" x 30"

 M
W13-1
24" x 24"

 P

SIGNAL HEAD ID

NO.	DATE	BY	DESCRIPTION

MALFUNCTION MANAGEMENT UNIT / CONFLICT MONITOR

PROGRAMMING DETAIL

(program card and tables as shown)

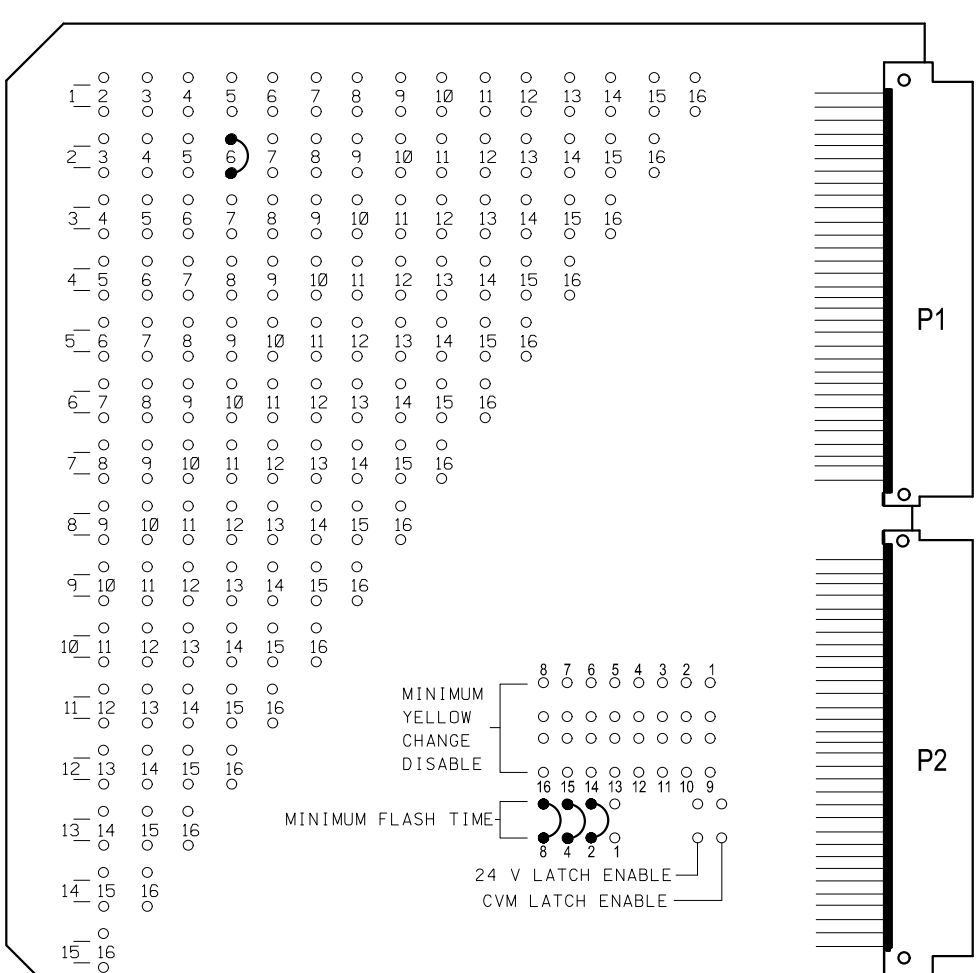

FIELD CHECK ENABLE

CHANNEL NUMBER	ENABLE/DISABLE
1	DISABLE
2	ENABLE
3	DISABLE
4	ENABLE
5	DISABLE
6	ENABLE
7	DISABLE
8	DISABLE
9	DISABLE
10	DISABLE
11	DISABLE
12	DISABLE
13	DISABLE
14	DISABLE
15	DISABLE
16	DISABLE

ECONOLITE EOS-2070 SPECIAL MMU PROGRAMMING

(program controller as shown)

- From Main Menu select **1. CONFIGURATION**
- From CONFIGURATION Submenu select **1. CABINET**
- From PORT 1 (SDLC) Submenu select **4. MONITOR PROGRAMMING**

CAUTION!

Set intersection to Flash before attempting to enter or change any MMU programming data.

This programming and that of the MMU programming card must match exactly. If they do not, the intersection will be placed into Flash.

MMU PROGRAM [MANUAL]

CH	6	5	4	3	2	1	0	9	8	7	6	5	4	3	2
1
2	X
3
4
5
6
7
8
9
10
11
12
13
14
15

END PROGRAMMING

DETECTOR RACK SETUP

INSERT DETECTOR CARDS IN RACK ACCORDING TO THE DETAIL SHOWN BELOW. PARTICULAR DETECTOR CHANNELS WILL CALL PHASES INDICATED.

DET BIU #1	DETECTION	CH3	CH1	COMMUNICATOR REMOTE	SLOT	SLOT	SLOT	SLOT	DET BIU #2
		L7 Ø 4	L5 Ø 4		EMPTY	EMPTY	EMPTY	EMPTY	
		L8 NOT USED	L6 Ø 4						

DETECTOR NUMBER	AMP. NO.	SIZE / ZONE	Ø	AMP. TYPE	DELAY DISABLE	COMMENTS:
V21,V22	1	6'x20'	2	N		130' FROM STOPLINE (THRU) (CAMERA #1)
V23,V24	2	6'x20'	2	N		280' FROM STOPLINE (THRU) (CAMERA #1)
42	3	6'x25'	4	N		STOPBAR
43	8	6'x25'	4	D	4	STOPBAR
45	4	6'x6'	4	S		55' FROM STOPBAR
V61,V62,63	5	6'x20'	6	N		130' FROM STOPLINE (THRU) (CAMERA #2)
V64,V65,V66	6	6'x20'	6	N		280' FROM STOPLINE (THRU) (CAMERA #2)

NOTE:
 ALL STOPBAR LOOPS EXTEND TO THE PROJECT CURB LINE UNLESS OTHERWISE NOTED.
 ALL LOOPS RECEIVE THREE TURNS.

PROJECT REFERENCE NO. **I-5973**

SHEET NO. **SIG. 3.3**

Plans Prepared By: **Kimley-Horn**
 421 FAIRVIEW STREET, SUITE 600
 RAINIER, WA 98148
 PHONE 206-487-2600

REVISION DESCRIPTION

NO.	DATE	BY	DESCRIPTION

DOCUMENT NOT CONSIDERED FINAL UNLESS ALL SIGNATURES COMPLETED

SIGNED: *SALPH* 2/16/2022
 SEAL 032607
 STATE OF WASHINGTON
 PROFESSIONAL ENGINEER

SIP PREPARED BY: _____ DATE: 9/2021

SIGNAL NO. 00896
 NCDOT ID NO. 10-1853

BROOKSHIRE BLVD. @ I-485 INNER RAMP

TEMPORARY SIGNAL DETAILS

SHEET **SIG3.3** OF **SIG3.6**

MMU PROGRAMMING NOTE:
 ENSURE YELLOW CHANGE PLUS RED CLEARANCE MONITORING IS ENABLED FOR ALL CHANNELS.

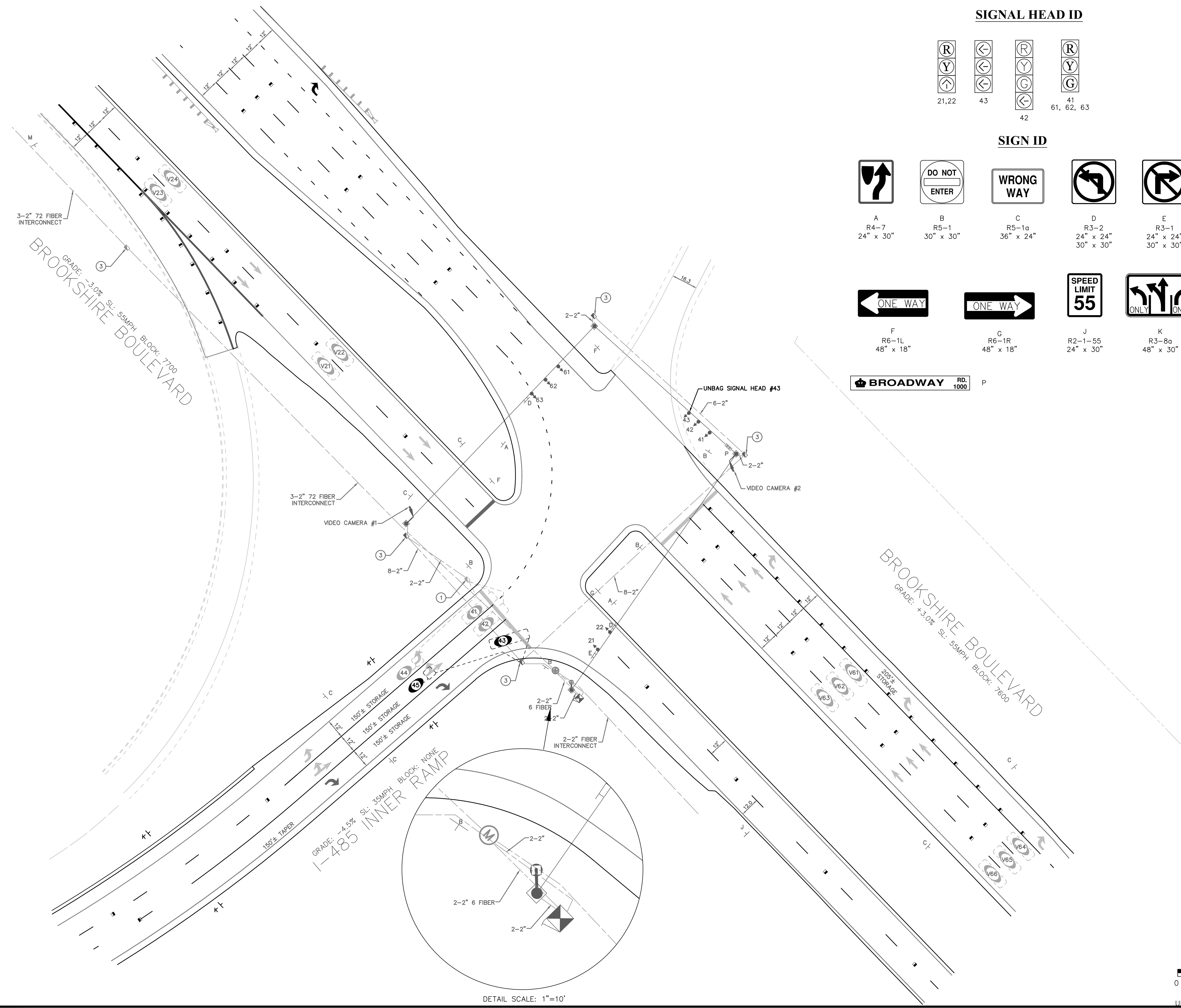

SIGNAL HEAD ID

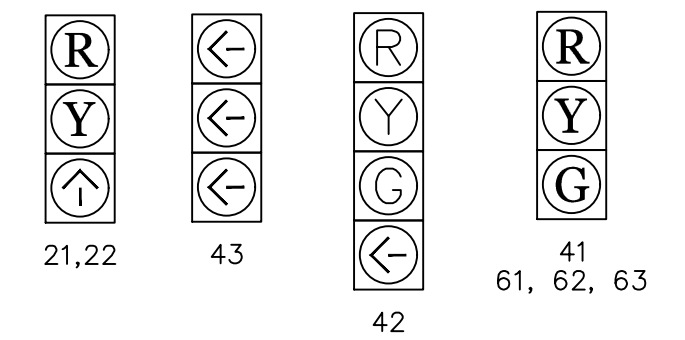

SIGN ID

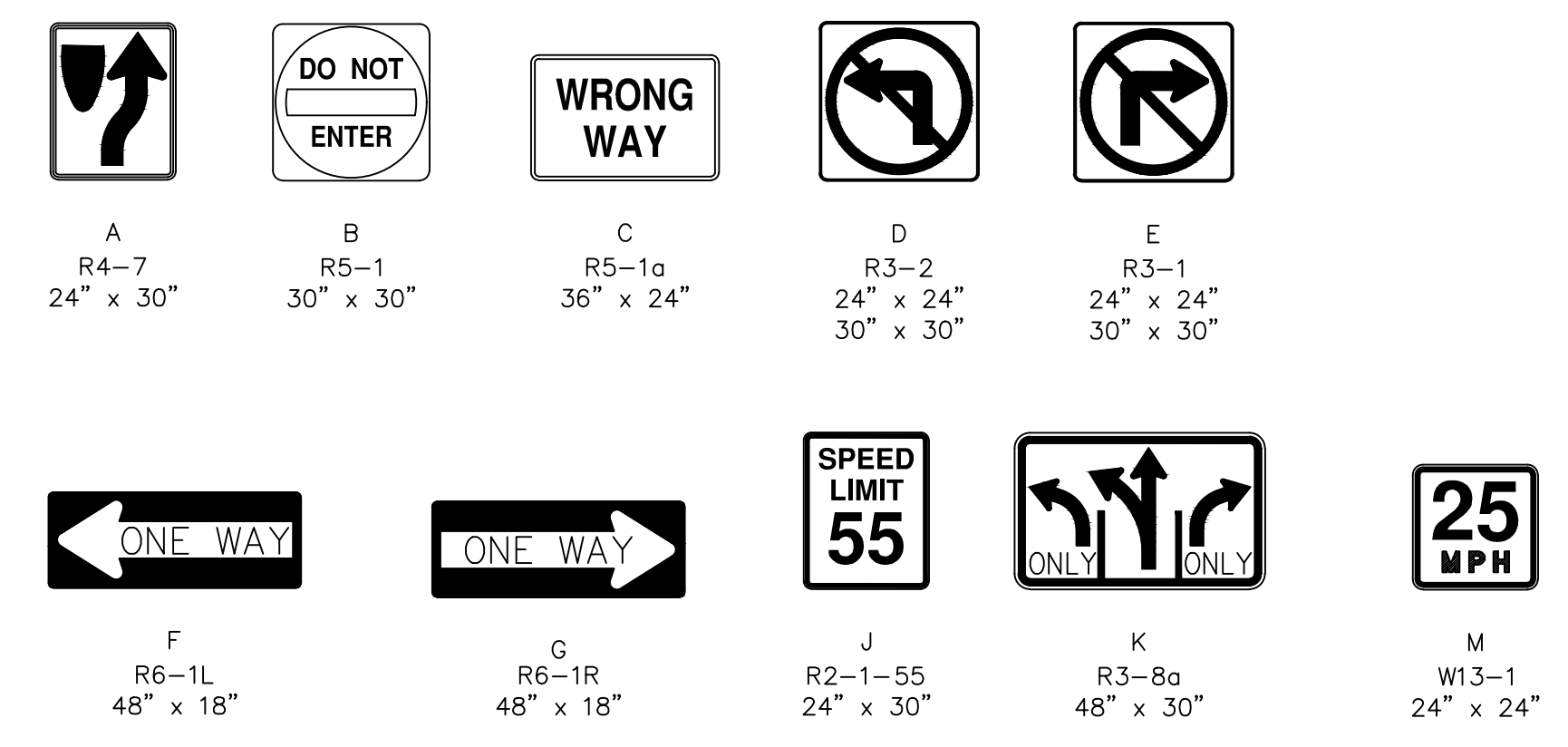

PROJECT REFERENCE NO. **I-5973**

SHEET NO. **SIG. 3.4**

Plans Prepared By: **Kimley-Horn**
 421 FAYETTEVILLE STREET, SUITE 600
 RALEIGH, NORTH CAROLINA 27601
 PHONE: 919-977-2000

NO.	DATE	BY	REVISION DESCRIPTION

DOCUMENT NOT CONSIDERED FINAL UNLESS ALL SIGNATURES COMPLETED

Seal: NORTH CAROLINA PROFESSIONAL SEAL 032607 CIVIL ENGINEER PHILIP

DocuSigned by: *SALPH* 2/16/2022
 DC87A56ED068437

00896 SIGNAL NO.	10-1853 NDOT ID NO.	SUP PREPARED BY	9/2021 DATE
---------------------	------------------------	--------------------	----------------

BROOKSHIRE BLVD. @ I-485 INNER RAMP

FINAL SIGNAL PLAN

SHEET **SIG3.4** OF **SIG3.6**

SCALE : 1"=30'
UNLESS OTHERWISE NOTED

DETAIL SCALE: 1"=10'

SIGNAL PHASING	
Ring Configuration	1,2,3,4,5,6
1 NOT USED	5 NOT USED
2	6
3 NOT USED	7 NOT USED
4	8 NOT USED

SIGNAL SEQUENCE							
RING 1	PHASE 1	PHASE 2	PHASE 3	PHASE 4	PHASE 5	PHASE 6	PHASE 7
SIGNAL ID NUMBER	R/W	OTH	R/W	OTH	R/W	OTH	R/W
21,22			▲	Y			
41					G	Y	R
42							◀
43							◀

OVERLAP PHASE							
OVERLAP PHASE	OL-A/-/+	OL-B/-/+	OL-C/-/+	OL-D/-/+	FLASH	FLASH	FLASH
SIGNAL ID NUMBER	R/W	OTH	R/W	OTH	R/W	OTH	R/W
21,22							
41							
42							
43							

TURNING MOVEMENT COUNT								
Phase	1	2	3	4	5	6	7	8
% Grade	0.0%	-3.0%	0.0%	-4.5%	0.0%	3.0%	0.0%	0.0%
Distance		60		115		65		
Approach Speed (mph)		55		35		55		
Yellow		5.5		4.2		4.9		
All Red		1.0		2.5		1.0		
Total Clearance		6.5		6.7		5.9		

SIGN ID				

PROJECT REFERENCE NO. **I-5973**

SHEET NO. **SIG. 3.5**

Plans Prepared By: **Kimley-Horn**

421 FAYETTEVILLE STREET, SUITE 600
RALEIGH, NORTH CAROLINA, 27601
PHONE 919-497-7200

MALFUNCTION MANAGEMENT UNIT / CONFLICT MONITOR

PROGRAMMING DETAIL
(program card and tables as shown)

CHANNEL NUMBER	ENABLE/DISABLE
1	DISABLE
2	ENABLE
3	DISABLE
4	ENABLE
5	DISABLE
6	ENABLE
7	DISABLE
8	DISABLE
9	DISABLE
10	DISABLE
11	DISABLE
12	DISABLE
13	DISABLE
14	DISABLE
15	DISABLE
16	DISABLE

ECONOLITE EOS-2070 SPECIAL MMU PROGRAMMING
(program controller as shown)

- From Main Menu select **1. CONFIGURATION**
- From CONFIGURATION Submenu select **1. CABINET**
- From PORT 1 (SDLC) Submenu select **4. MONITOR PROGRAMMING**

CAUTION!
Set intersection to Flash before attempting to enter or change any MMU programming data.
This programming and that of the MMU programming card must match exactly. If they do not, the intersection will be placed into Flash.

```

MMU PROGRAM [ MANUAL ]

CH 6 5 4 3 2 1 0 9 8 7 6 5 4 3 2
1 . . . . .
2 . . . . . X . . .
3 . . . . .
4 . . . . .
5 . . . . .
6 . . . . .
7 . . . . .
8 . . . . .
9 . . . . .
10 . . . . .
11 . . . . .
12 . . . . .
13 . . . . .
14 . . . . .
15 . . . . .
    
```

END PROGRAMMING

DETECTOR RACK SETUP

INSERT DETECTOR CARDS IN RACK ACCORDING TO THE DETAIL SHOWN BELOW. PARTICULAR DETECTOR CHANNELS WILL CALL PHASES INDICATED.

DET BIU #1	DEFINITION	CH3 L7	CH1 L5	COMMUNICATIONS	SLOT	SLOT	SLOT	SLOT	DET BIU #2
		Ø 4	Ø 4	COMMUNICATIONS	EMPTY	EMPTY	EMPTY	EMPTY	
		Ø 4	Ø 4	COMMUNICATIONS	EMPTY	EMPTY	EMPTY	EMPTY	

DETECTOR NUMBER	AMP. NO.	SIZE / ZONE	Ø	AMP. TYPE	DELAY DISABLE Ø	COMMENTS:
V21,V22	1	6'X20'	2	N		130' FROM STOPLINE (THRU) (CAMERA #1)
V23,V24	2	6'X20'	2	N		280' FROM STOPLINE (THRU) (CAMERA #1)
41,42	3	6'x25'	4	N		STOPBAR
43	8	6'x25'	4	D	4	STOPBAR
44,45	4	6'x6'	4	S		56' FROM STOPBAR
V61,V62,63	5	6'X20'	6	N		130' FROM STOPLINE (THRU) (CAMERA #2)
V64,V65,V66	6	6'X20'	6	N		280' FROM STOPLINE (THRU) (CAMERA #2)

NOTE:
ALL STOPBAR LOOPS EXTEND TO THE PROJECT CURB LINE UNLESS OTHERWISE NOTED.
ALL LOOPS RECEIVE THREE TURNS.

REVISION DESCRIPTION

NO.	DATE	BY

Seal: NORTH CAROLINA PROFESSIONAL SEAL 032607 DATE 9/2021

Prepared By: SLP DATE 9/2021

00896 SIGNAL NO. 10-1853 NCDOT ID NO.

BROOKSHIRE BLVD. @ I-485 INNER RAMP

SIG3.5

SIG3.6

FINAL SIGNAL DETAILS

MMU PROGRAMMING NOTE
ENSURE YELLOW CHANGE PLUS RED CLEARANCE MONITORING IS ENABLED FOR ALL CHANNELS.

**MODIFY EXISTING SPLICE ENCLOSURE IN EXISTING MANHOLE (MH2) AT BROOKSHIRE BLVD. AT I-485 NB INNER RAMP
SIG. INV# 00896 (10-1853)**

COLOR CODE TIA/EIA 598-A		LEGEND	
(1) BLUE	(7) RED	○ EXISTING SPLICE	▭ BUFFER TUBE
(2) ORANGE	(8) BLACK	● NEW SPLICE	
(3) GREEN	(9) YELLOW		
(4) BROWN	(10) VIOLET		
(5) SLATE	(11) ROSE		
(6) WHITE	(12) AQUA		

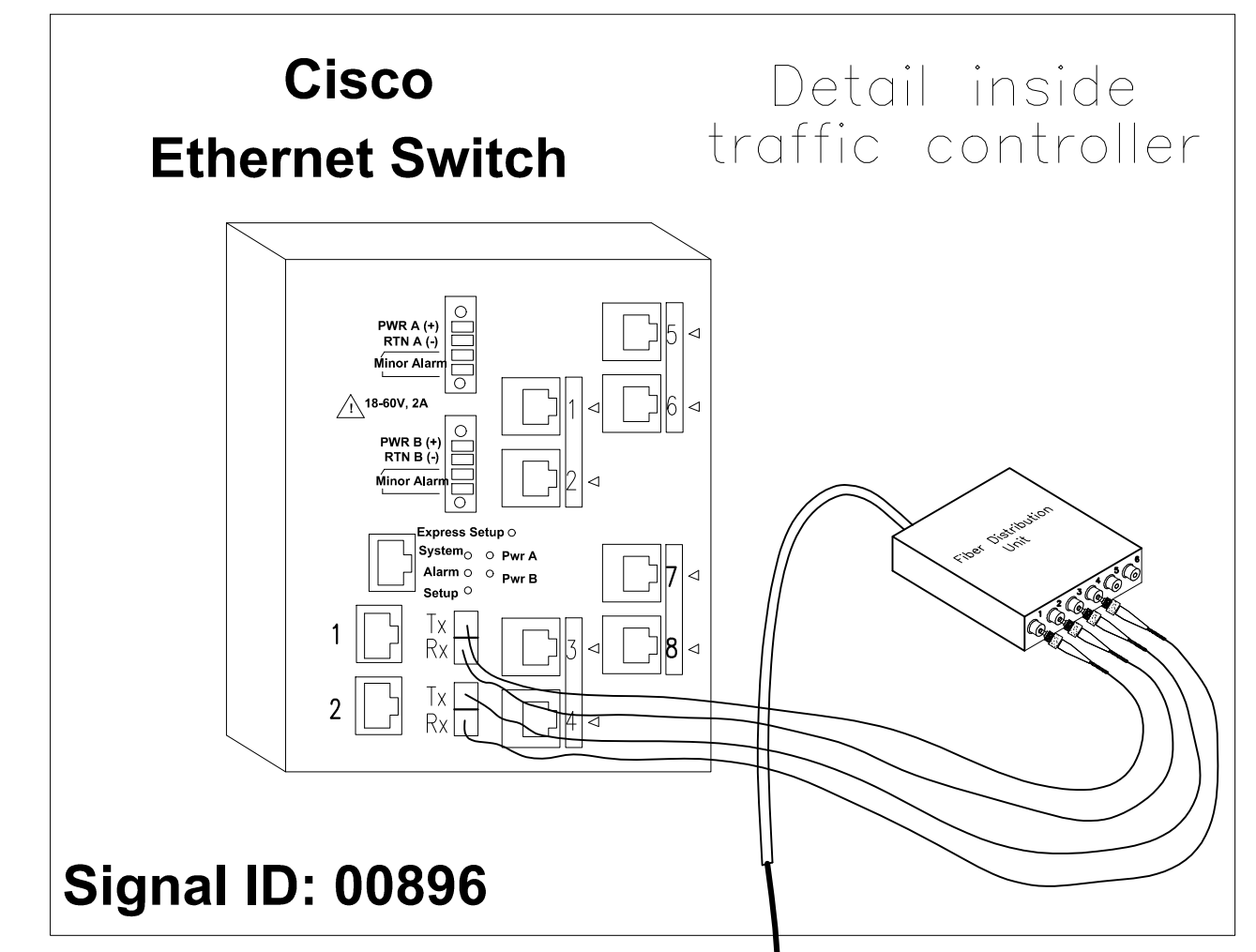

PROJECT REFERENCE NO. **I-5973**

SHEET NO. **SIG. 3.6**

Plans Prepared By: **Kimley Horn**
481 FAYETTEVILLE STREET, SUITE 400
SALUDA, NORTH CAROLINA, 27060
PHONE: 919-477-2000

NO.	DATE	BY	REVISION DESCRIPTION

DocuSigned by: *SAI PL* 2/16/2022
0071A5ED9B431

SIGNAL NO. 00896	SLP PREPARED BY	DATE 9/2021
10-1853		
NC DOT ID NO.		

BROOKSHIRE BLVD. @ I-485 INNER RAMP

SPLICE DETAIL

SHEET **SIG3.6** OF **SIG3.6**

DOCUMENT NOT CONSIDERED FINAL UNLESS ALL SIGNATURES COMPLETED

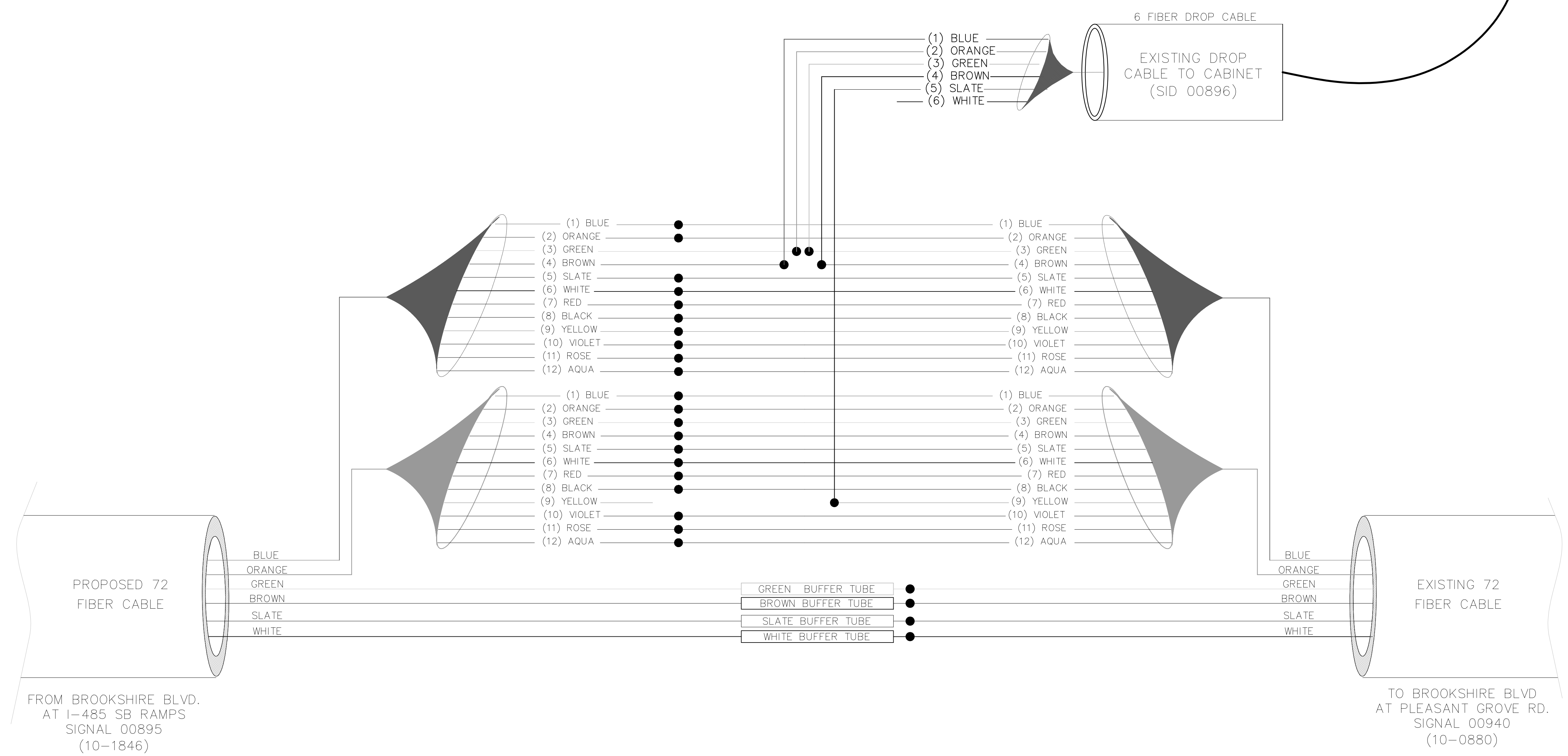

EXISTING SPLICE CASE IN MH# 2 (SEE SHEET CR9) AT BROOKSHIRE BLVD

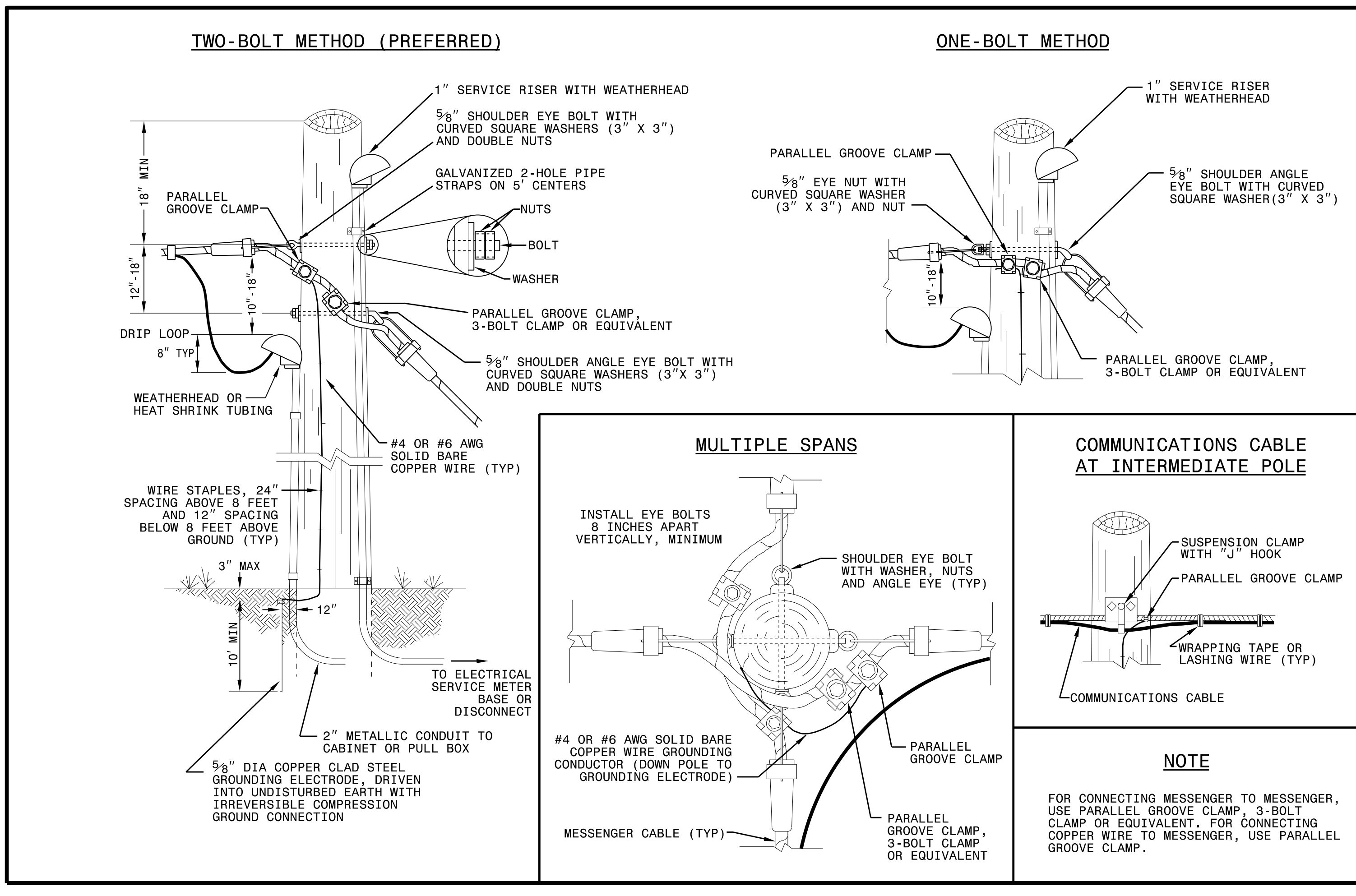
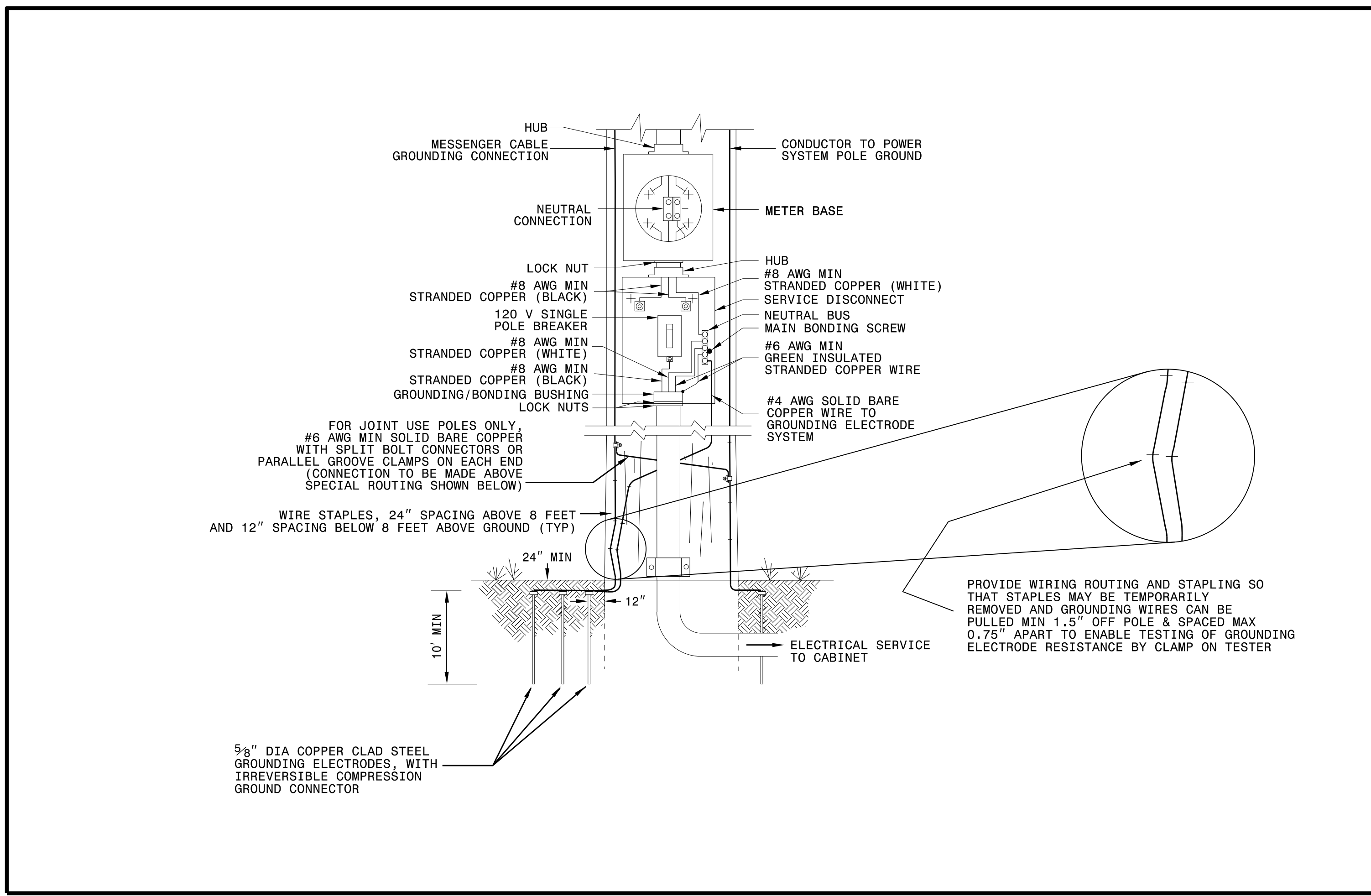

DOCUMENT NOT CONSIDERED
FINAL UNLESS ALL
SIGNATURES COMPLETED

See Plate for Title

Prepared in the Offices of:

SEAL

DocuSigned by:
Mohd Aslami

10/11/2017
DATE

750 N. Greenfield Parkway
Garner, NC 27529

11-0CT-2017_08:56
U:\2018_S14_Drawing\Plate_Sheets\2018_Plate_Sheet.dgn
r:\rough

STATE OF NORTH CAROLINA DIVISION OF HIGHWAYS

PROJECT I.D. NO.	SHEET NO.
	Sig.M1

STANDARD DRAWINGS FOR ALL METAL POLES

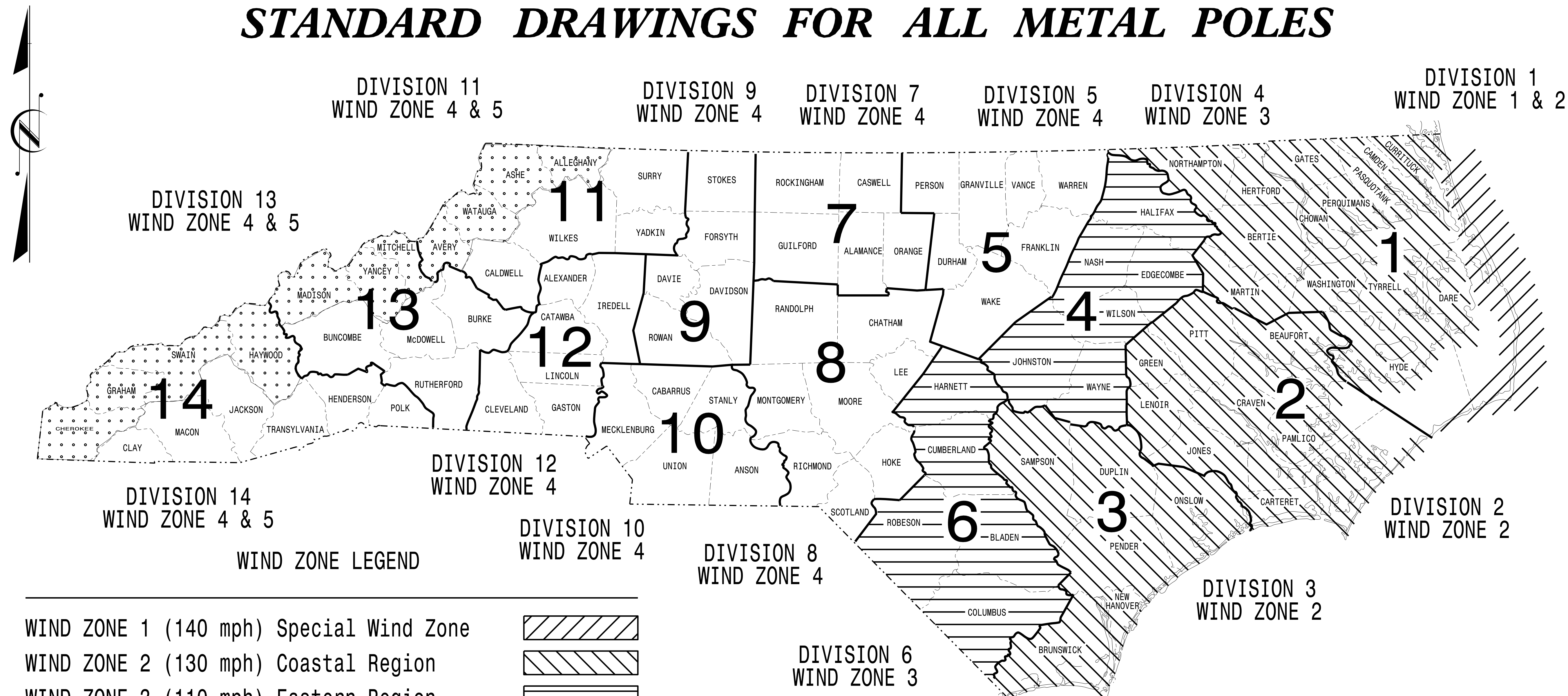

WIND ZONE LEGEND

WIND ZONE 1 (140 mph)	Special Wind Zone	
WIND ZONE 2 (130 mph)	Coastal Region	
WIND ZONE 3 (110 mph)	Eastern Region	
WIND ZONE 4 (90 mph)	Central & Mtn. Region	
WIND ZONE 5 (120 mph)	Special Wind Zone	

<https://connect.ncdot.gov/resources/safety/Pages/ITS-Design-Resources.aspx>

Prepared In the Offices of:

750 N. Greenfield Pkwy.
Garner, NC 27529

Designed in conformance
with the latest
2015 Interim to the
6th Edition 2013
AASHTO
Standard Specifications for
Structural Supports for
Highway Signs, Luminaires,
and Traffic Signals

DRAWING NUMBER	DESCRIPTION
Sig. M 1	Statewide Wind Zone Map
Sig. M 2	Typical Fabrication Details-All Metal Poles
Sig. M 3	Typical Fabrication Details-Strain Poles
Sig. M 4	Typical Fabrication Details-Mast Arm Poles
Sig. M 5	Typical Fabrication Details-Mast Arm Connection
Sig. M 6	Typical Fabrication Details-Strain Pole Attachments
Sig. M 7	Construction Details-Foundations
Sig. M 8	Standard Strain Pole Foundation-All Soil Conditions

NCDOT CONTACTS:

MOBILITY AND SAFETY DIVISION - ITS AND SIGNALS UNIT

M.M. MCDIARMID, P.E. - STATE ITS AND SIGNALS ENGINEER

J.P. GALLOWAY, P.E. - STATE SIGNALS ENGINEER

D.C. SARKAR, P.E. - ITS AND SIGNALS SENIOR STRUCTURAL ENGINEER

SEAL

DocuSigned by:
Debesh C. Sarkar
DATE 10/11/2017

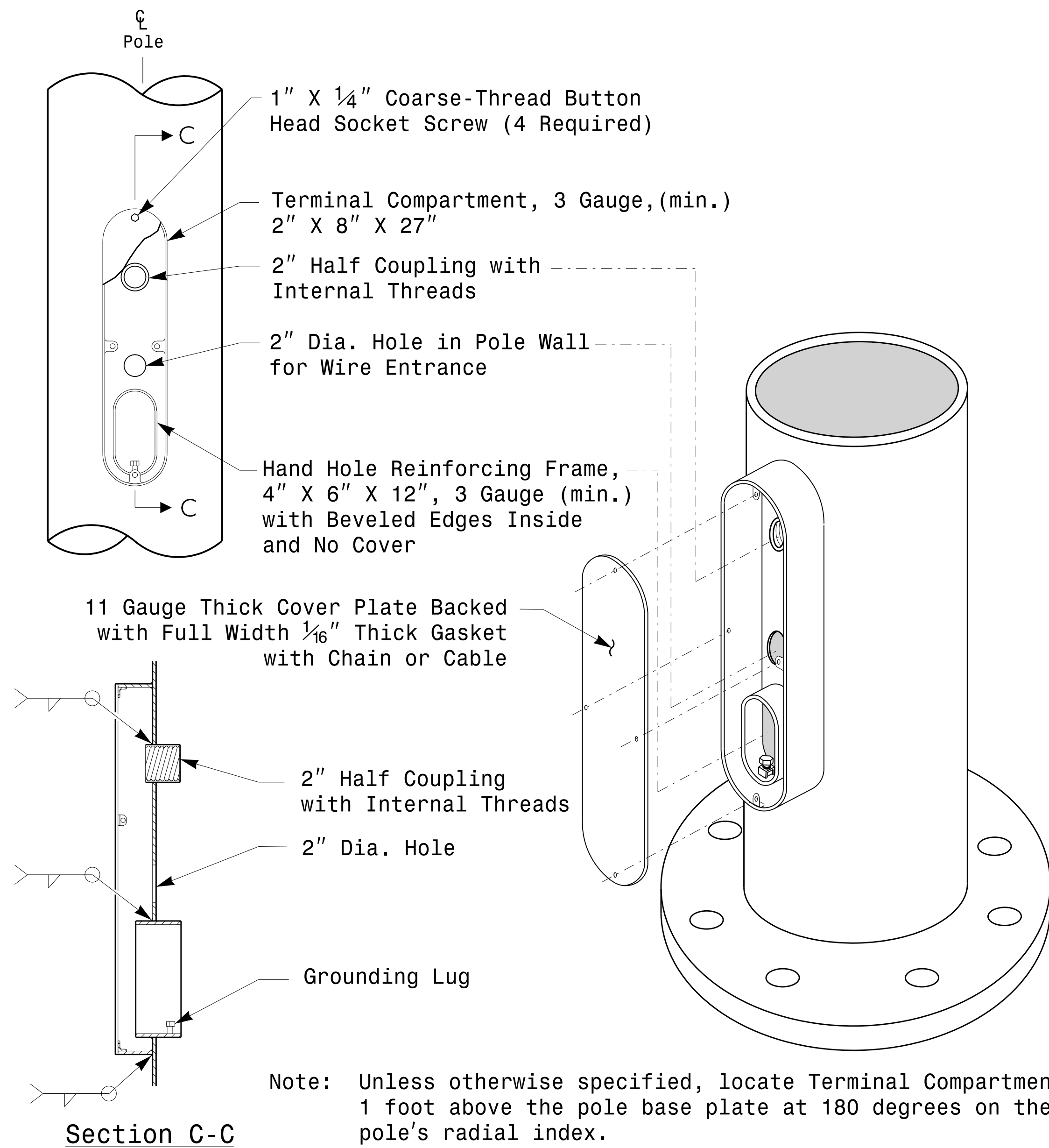

MFG	MFG. DATE: MM/YY
SHAFT D/T/L/Y/...../...../.....
ARM-A D/T/L/Y/...../...../.....
ARM-B D/T/L/Y/...../...../.....
A.B. DIA./B.C./L/Y/...../...../.....
NCDOT SIG. INV. NO.
NCDOT POLE NO.

MFG	MFG. DATE: MM/YY
SECTION D/T/L/Y/...../...../.....
NCDOT SIG. INV. NO.
NCDOT POLE NO.

Arm I.D. Tag
(Provide on each section of a multi-section mast arm.)

Shaft I.D. Tag
(Provide on Shaft of Strain Poles and Mast Arm Poles Shaft)

- Notes:**
- 1) D= Diameter, T= Thickness, L= Length, Y= Yield Strength
 - 2) A.B. = Anchor Bolt
 - 3) B.C. = Bolt Circle of Anchor Bolts
 - 4) If Custom Design, use "NCDOT STANDARD" line for Signal Inv. Number and pole I.D. number
 - 5) See drawing M3 and M4 for mounting positions of I.D. tags.

Identification Tag Details

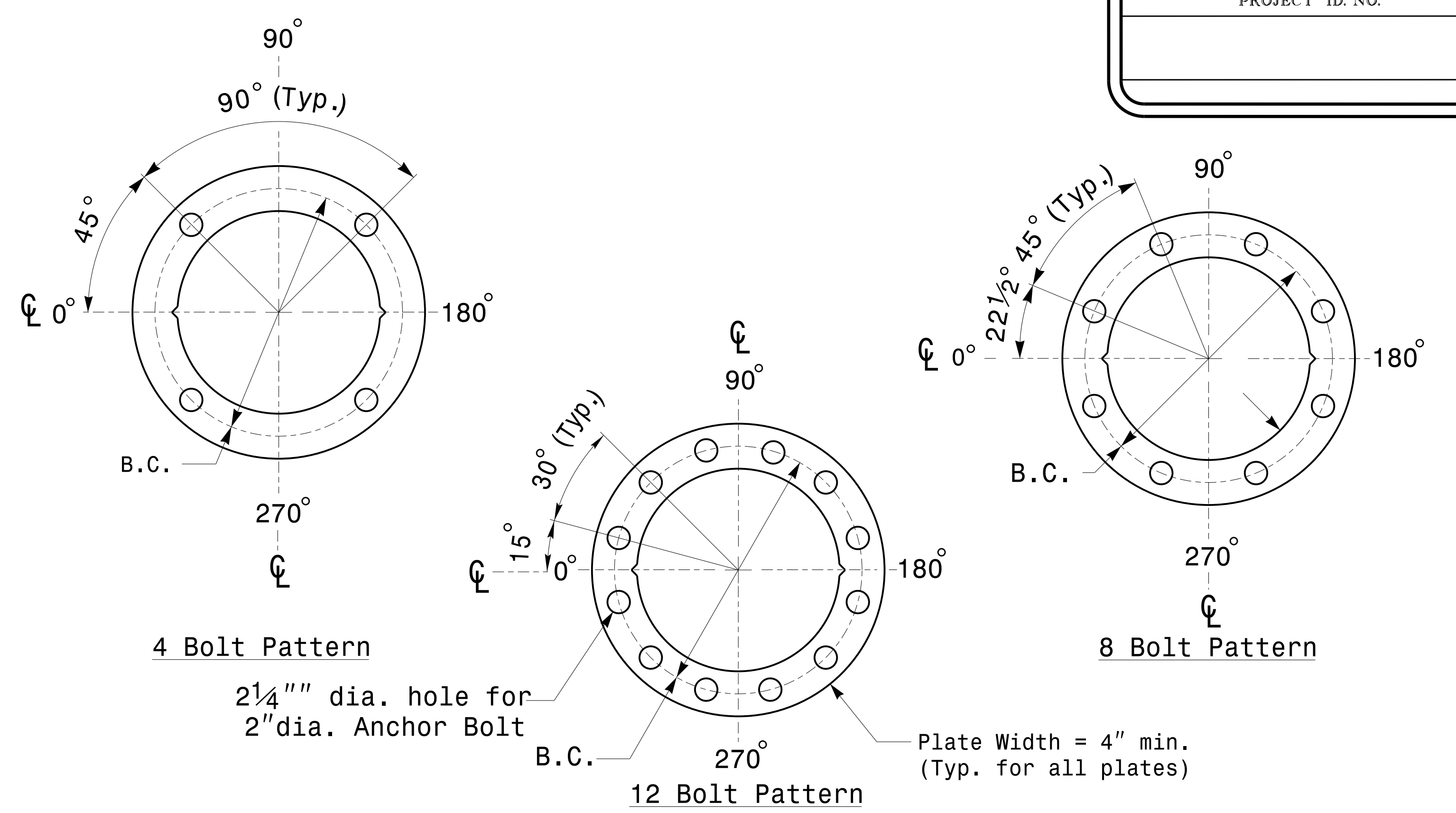

Construct Templates and Plates from 1/4" min. thick Steel. Galvanizing is not required.

Base Plate Template and Anchor Bolt Lock Plate Details

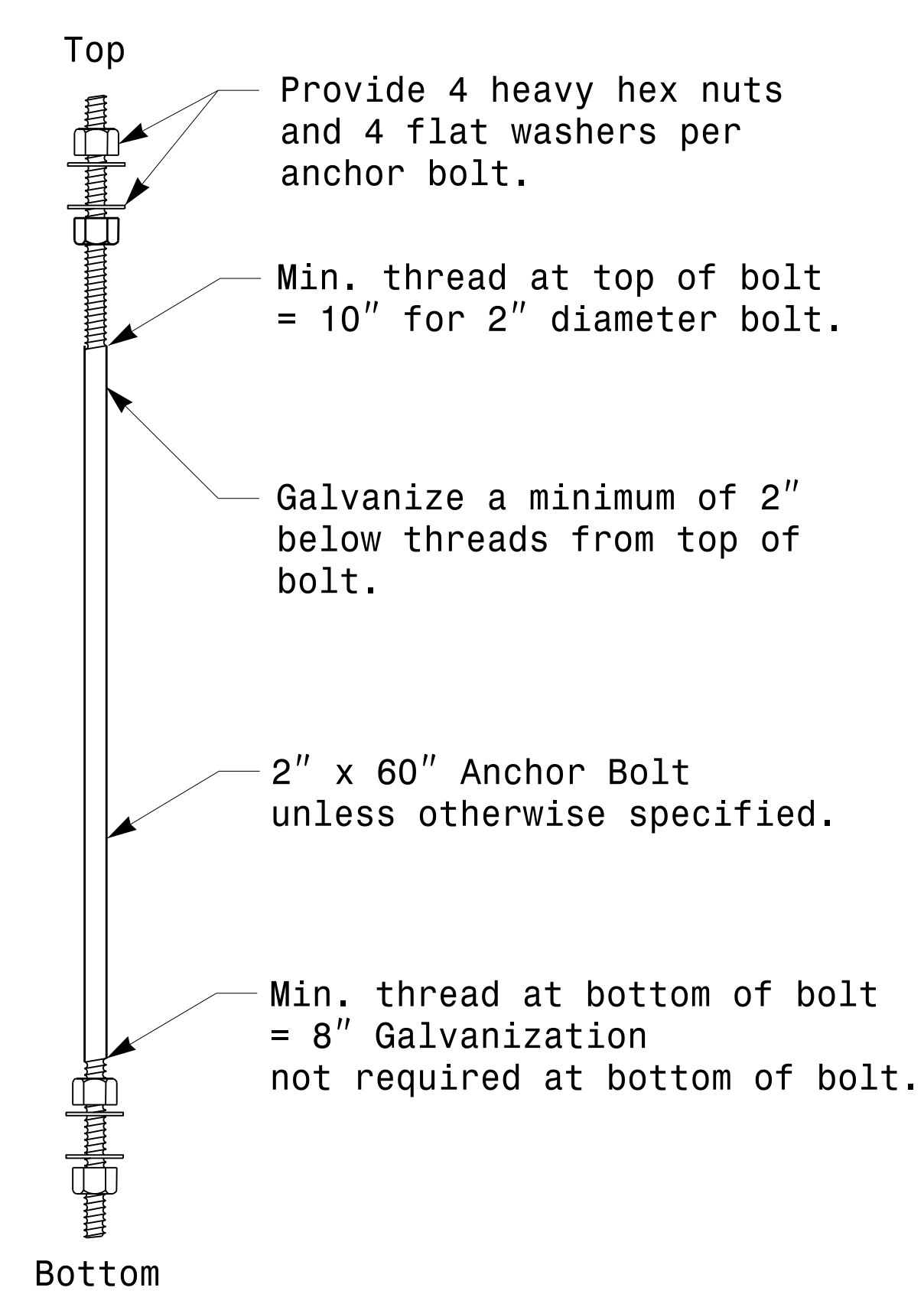

Anchor Bolt Detail

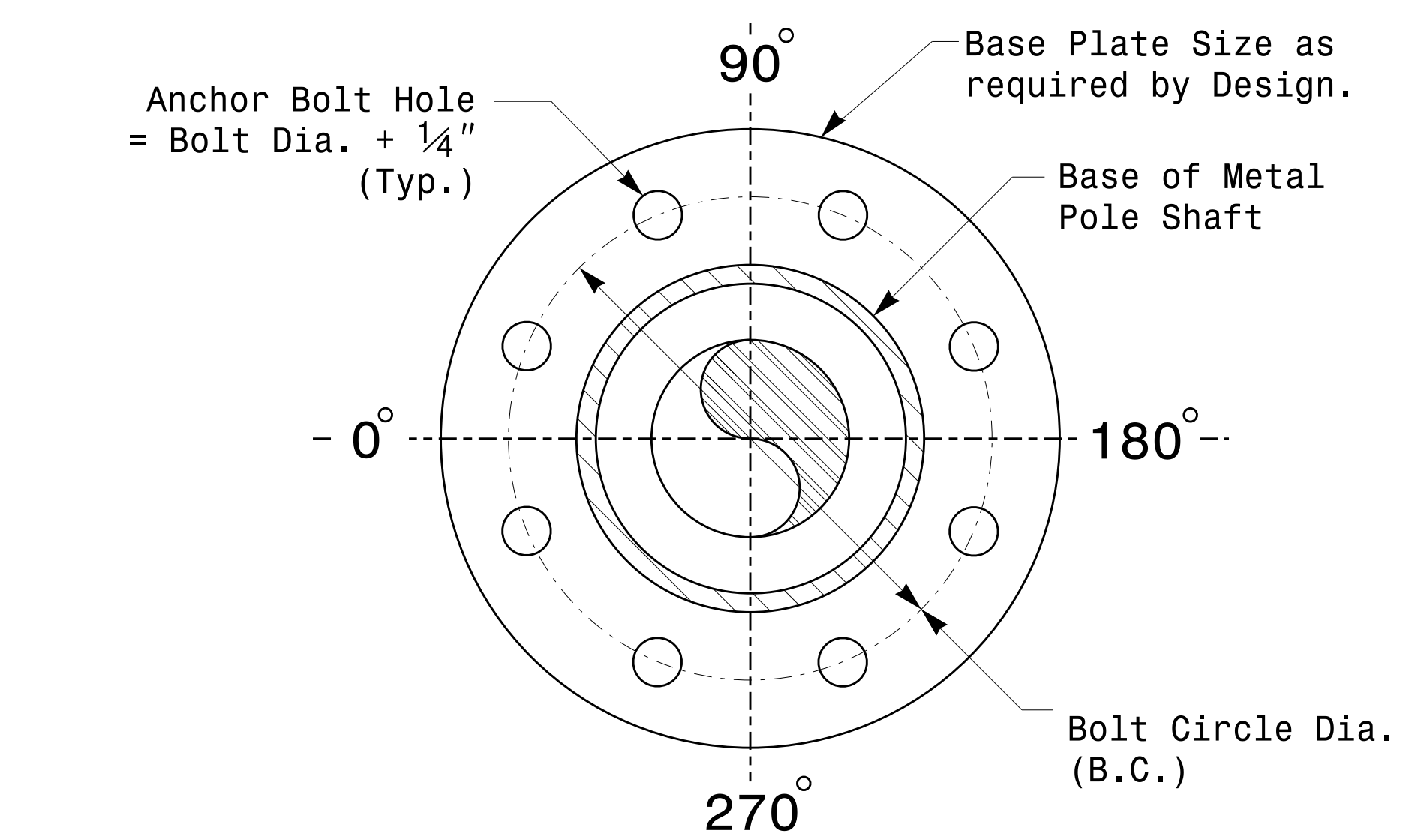

Note: Base plate may be circular, octagonal, square or rectangular in shape.

Typical Base Plate Detail



Typical Fabrication Details For All Metal Poles

PLAN DATE: OCTOBER 2017 DESIGNED BY: C.F. ANDREWS
PREPARED BY: N. BITTING REVIEWED BY: D.C. SARKAR

SCALE: NONE

REVISIONS	INIT.	DATE

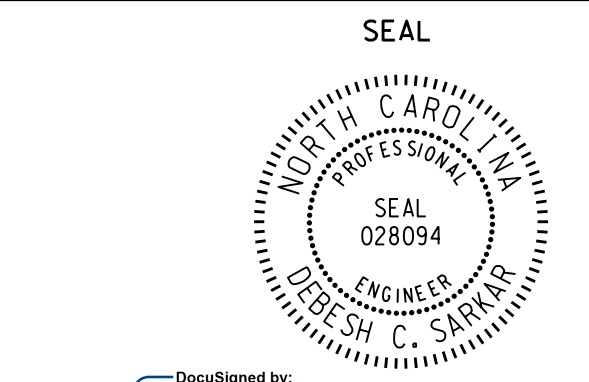

DocuSigned by: Dinesh C. Sarkar 10/11/2017 DATE

Note:
 1. Opening in pole base plate shall be equal to pole base inside diameter minus 3 1/2" but shall not be less than 8 1/2".

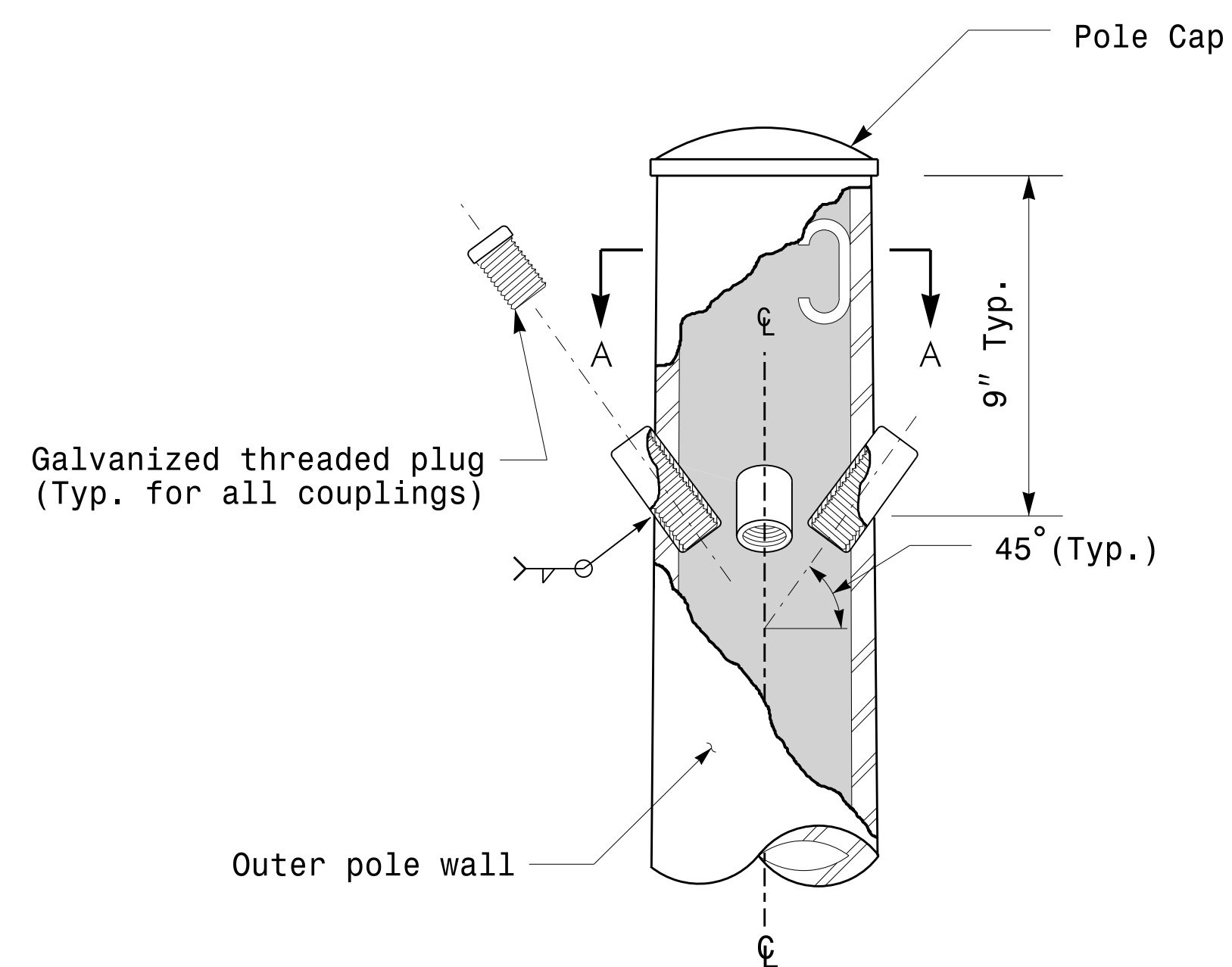

Cable Entrances at Top of Pole

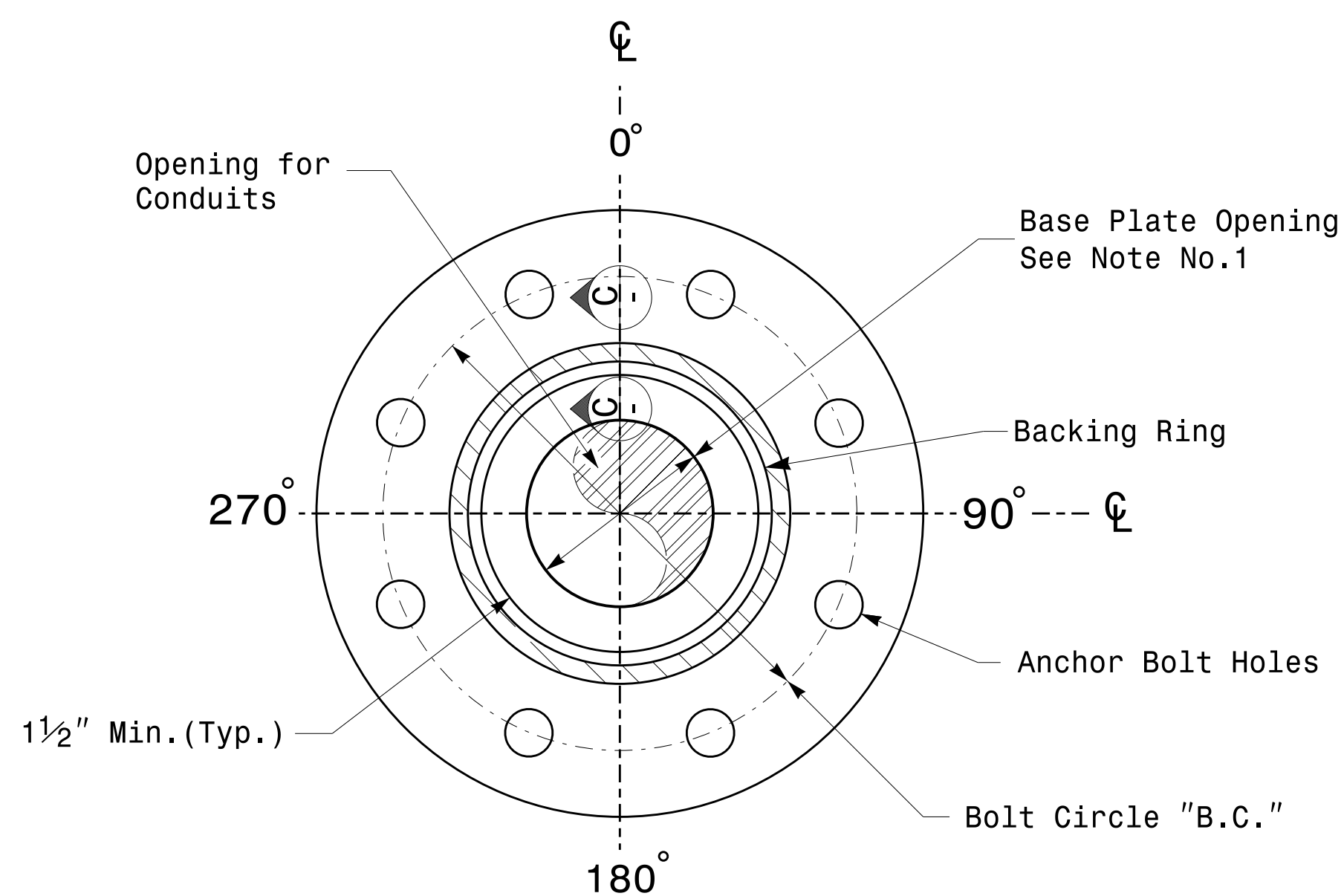

Section B-B
Pole Base Plate Details
(8 and 12 Bolt Pattern)

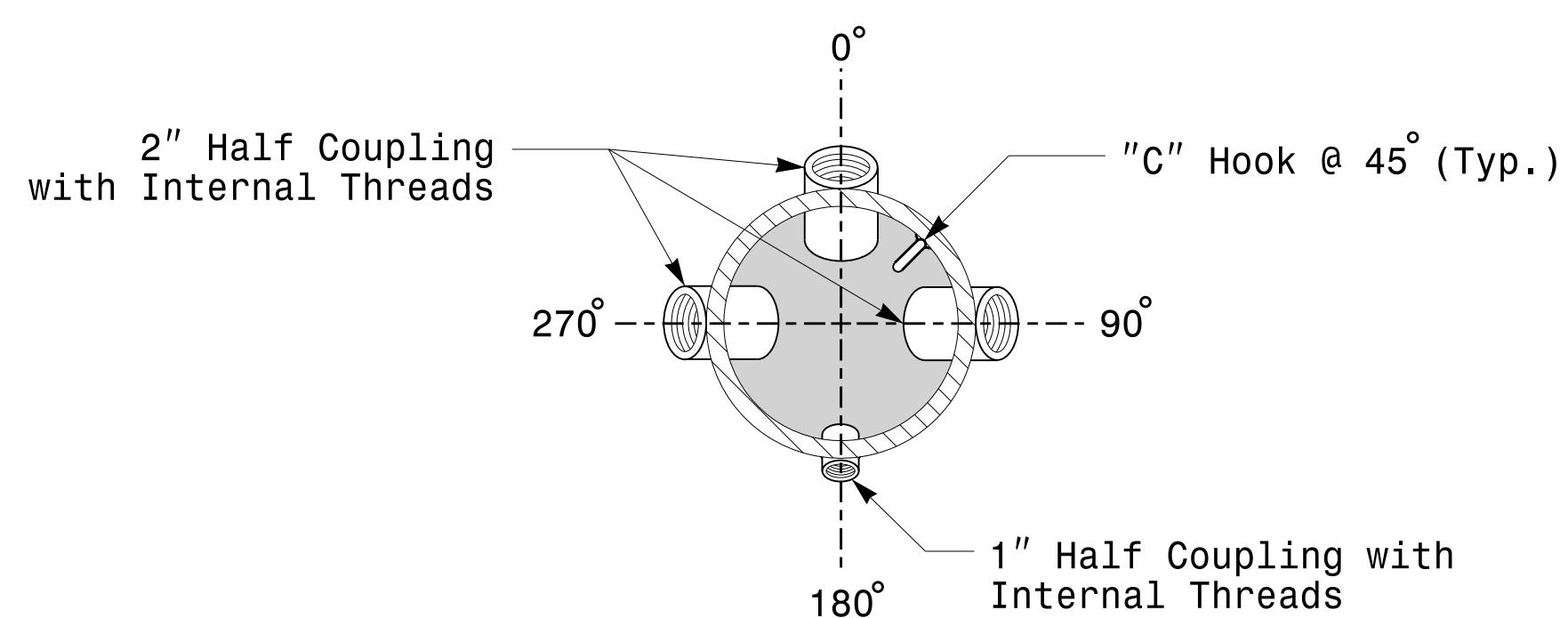

Section A-A
Radial Orientation for Factory Installed
Accessories at Top of Pole

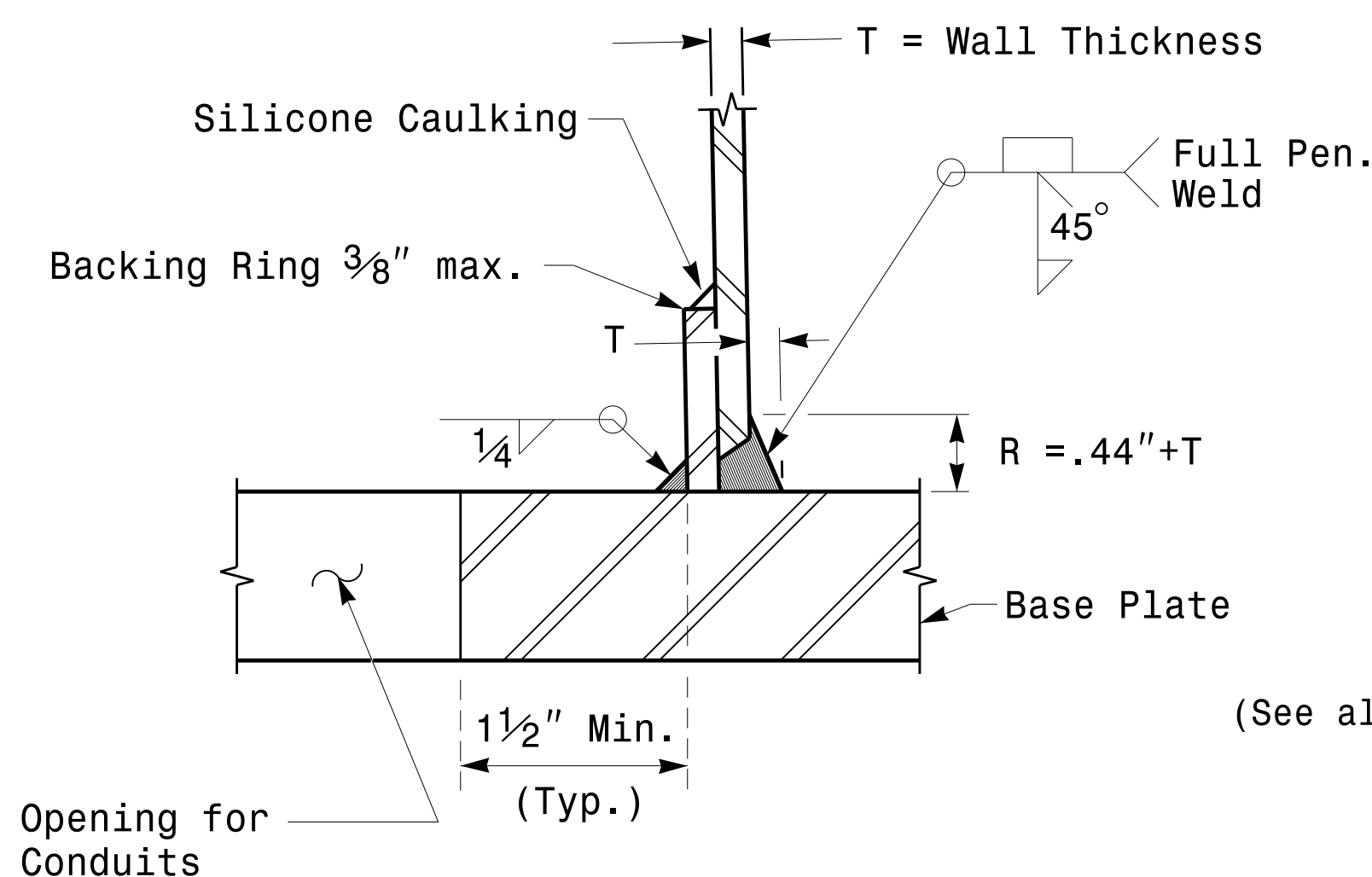

Section C-C
(Pole Attachment to Base Plate)
Full-Penetration
Groove Weld Detail

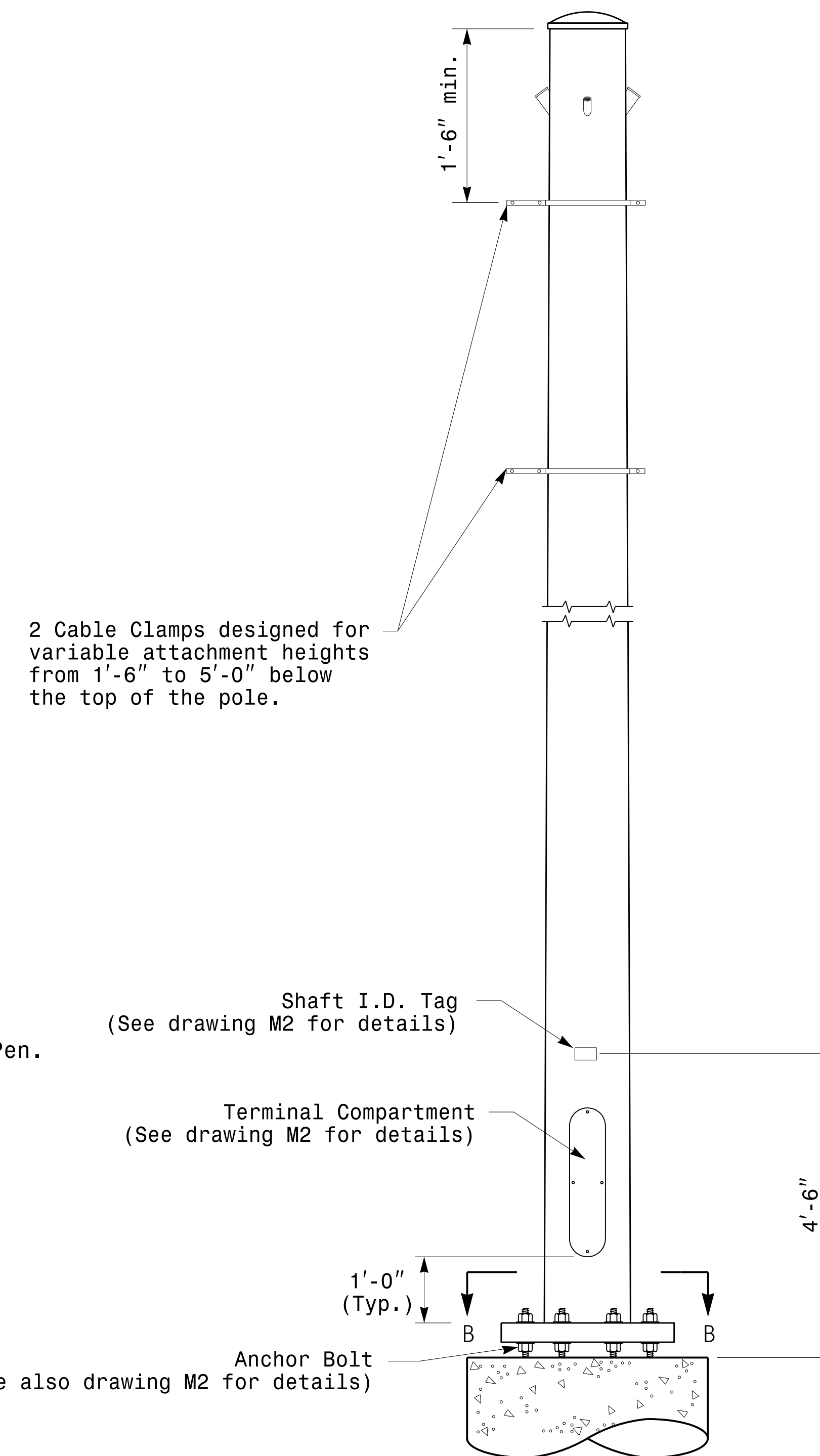

Monotube Strain Pole

Prepared in the Offices of:

 750 N. Greenleaf Pkwy, Garner, NC 27529

Typical Fabrication Details For Strain Poles

PLAN DATE: OCTOBER 2017	DESIGNED BY: K.C. DURIGON
PREPARED BY: N. BITTING	REVIEWED BY: D.C. SARKAR
REVISIONS	INIT. DATE

SEAL

 D.C. SARKAR
 ENGINEER
 448857816/FACILITY

DocuSigned by:
 D.C. Sarkar
 10/11/2017
 DATE

Fabrication Details – Strain Poles

Note:
 1. Opening in pole base plate shall be equal to pole base inside diameter minus 3 1/2" but shall not be less than 8 1/2".

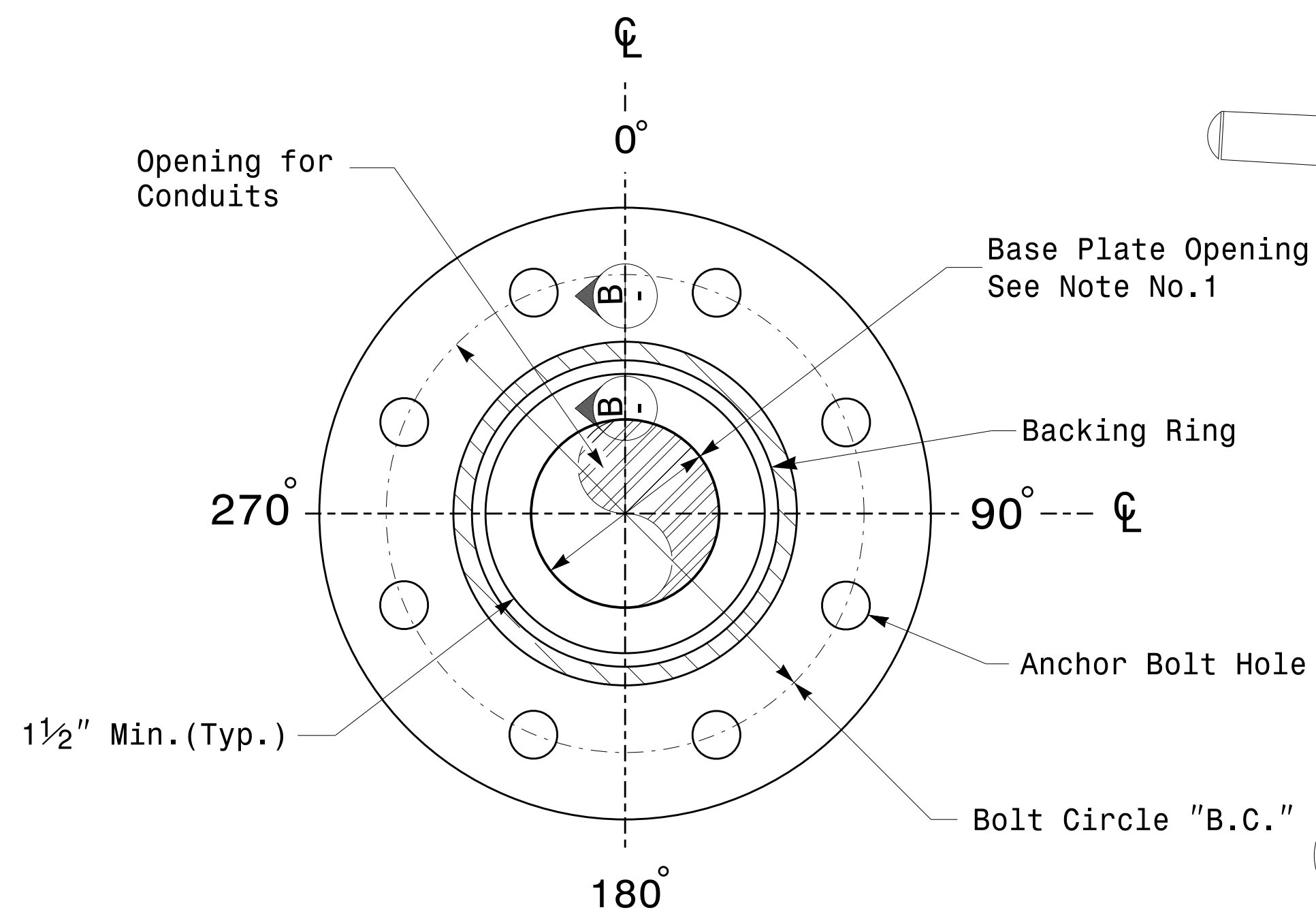

Section A-A
 Pole Base Plate Details

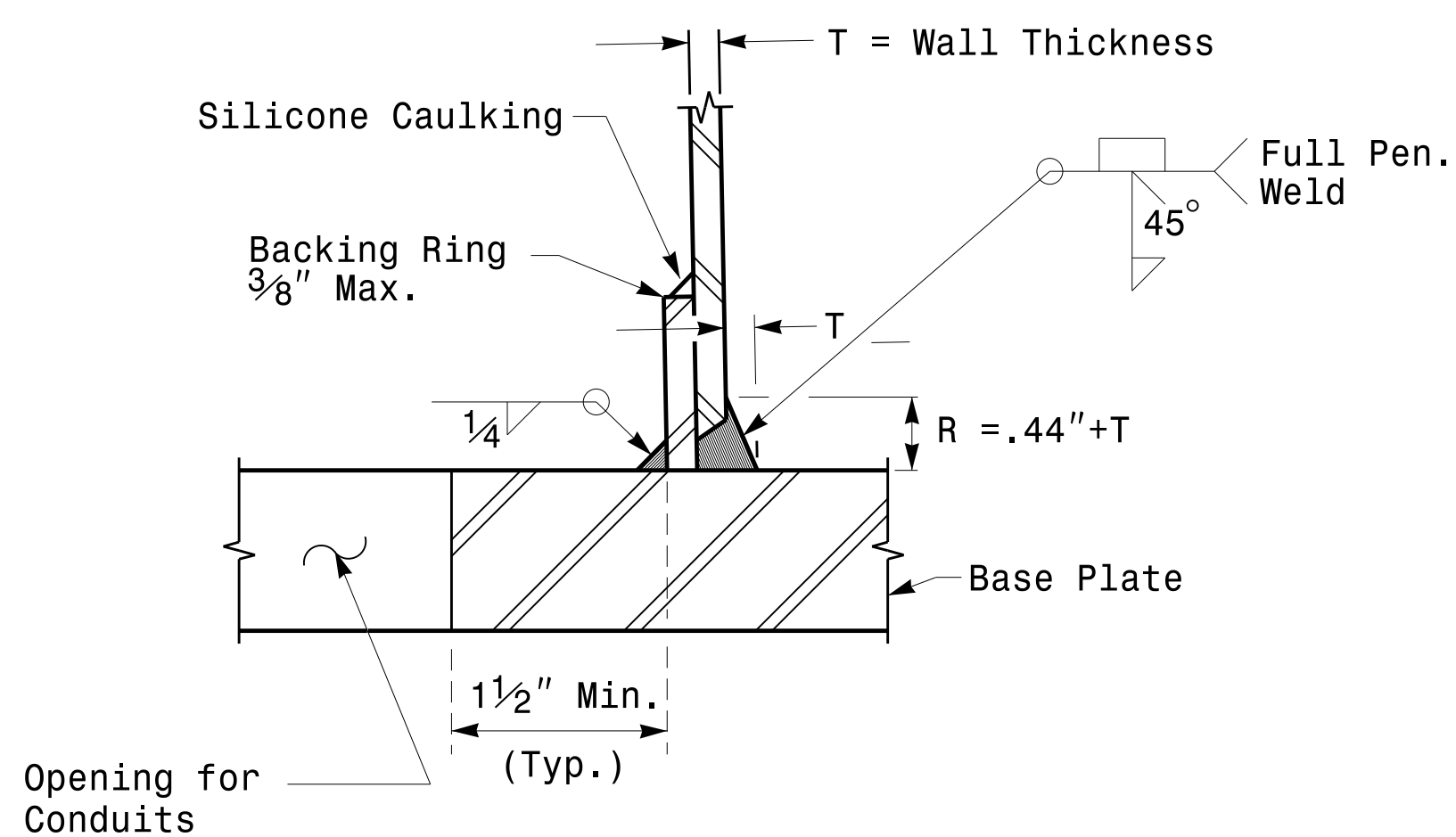

Section B-B
 (Pole Attachment to Base Plate)
 Full-Penetration Groove Weld Detail

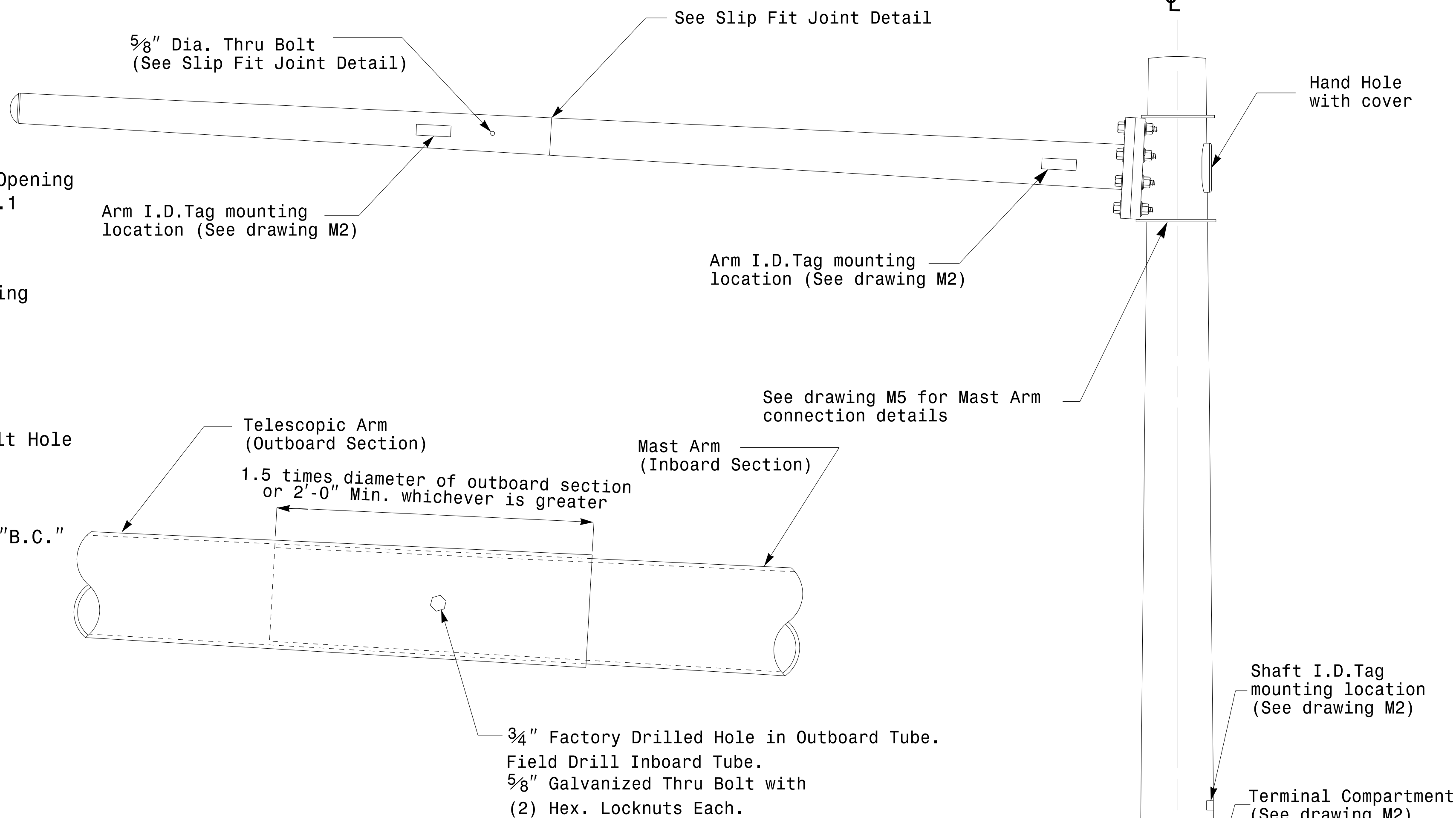

Slip Fit Joint Detail for Mast Arm

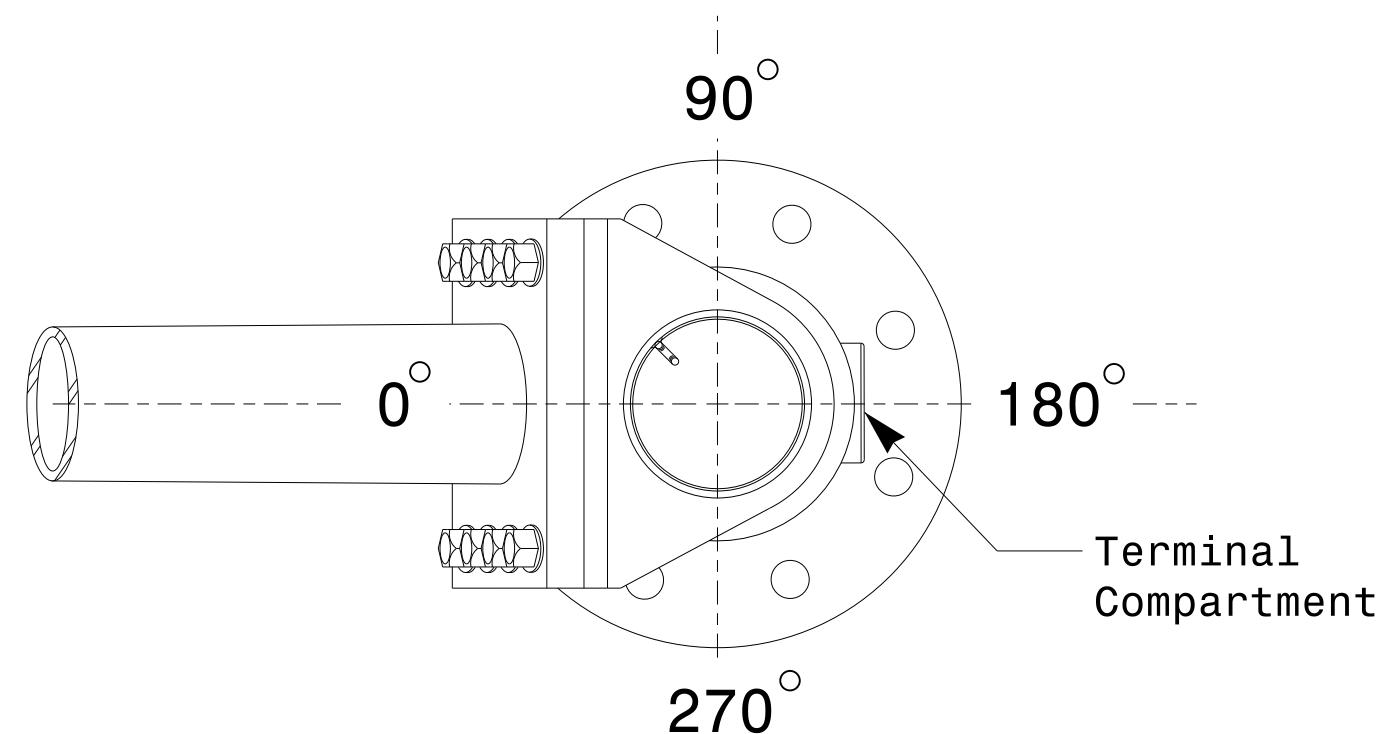

Mast Arm Radial Orientation

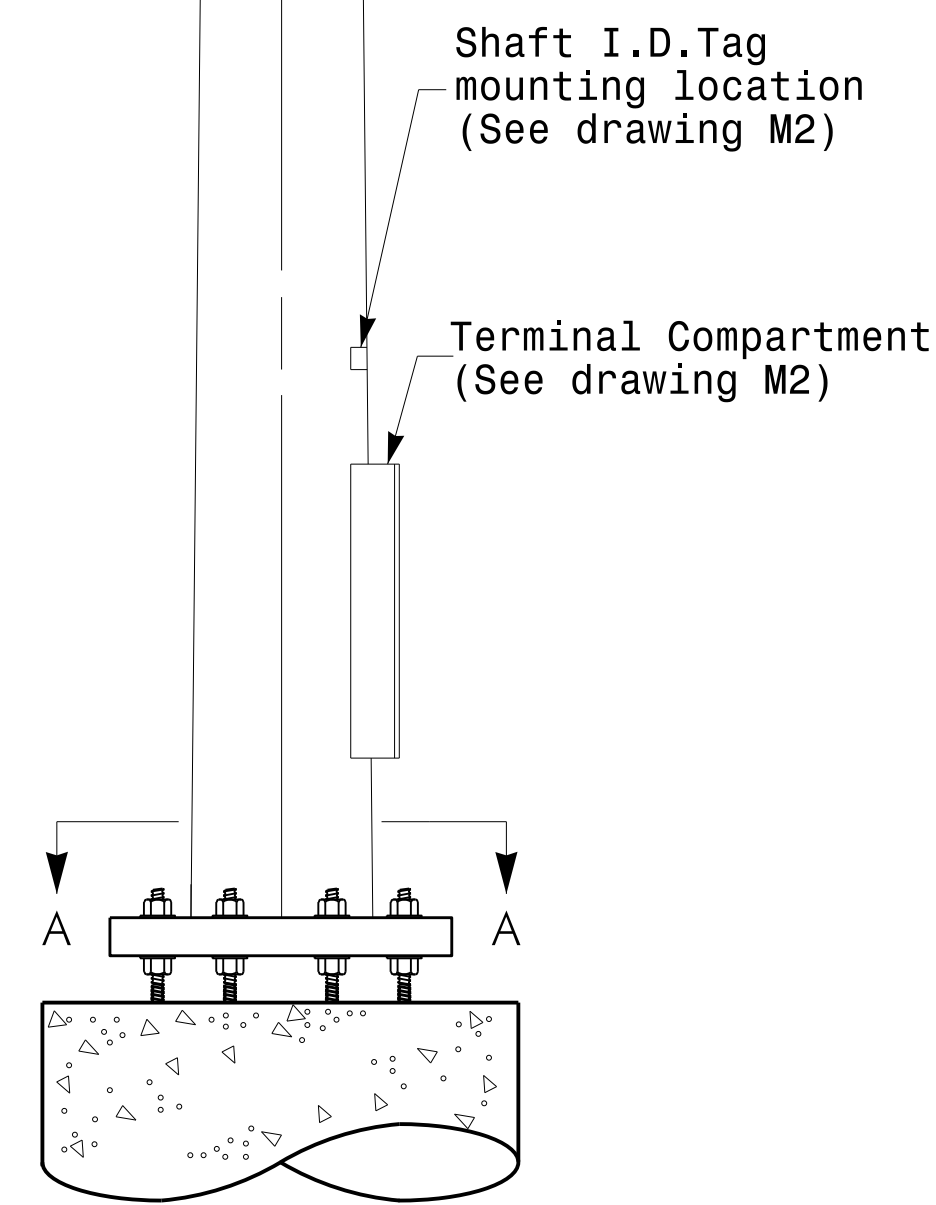

Mast Arm Pole

Fabrication Details - Mast Arm Poles

	Typical Fabrication Details For Mast Arm Poles		SEAL
	PLAN DATE: OCTOBER 2017 PREPARED BY: N. BITTING	DESIGNED BY: K.C. DURIGON REVIEWED BY: D.C. SARKAR	
SCALE: 0 NA NONE	DocuSigned by: Dinesh C. Sarkar		10/11/2017 DATE

11-OCT-2017 08:33 13650W115 Signal Design Section Eastern Region\m4 Sheets\2016\2014 Sig.M4 Std. Fabrication Detail-Mast Arm Poles.dgn

Welded Ring Stiffened Mast Arm Connection

PROJECT ID. NO.

SHEET NO.

Sig.M5

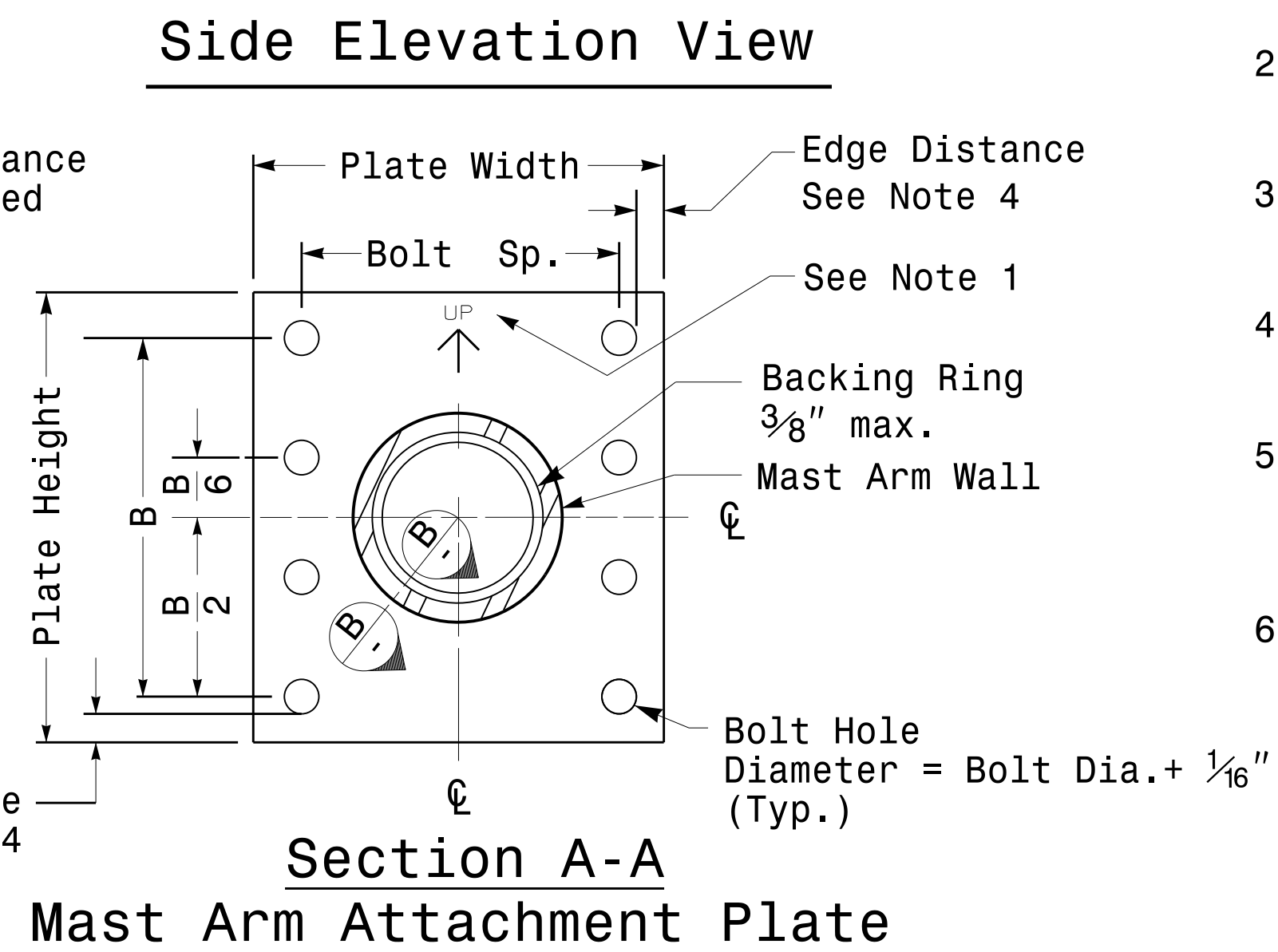
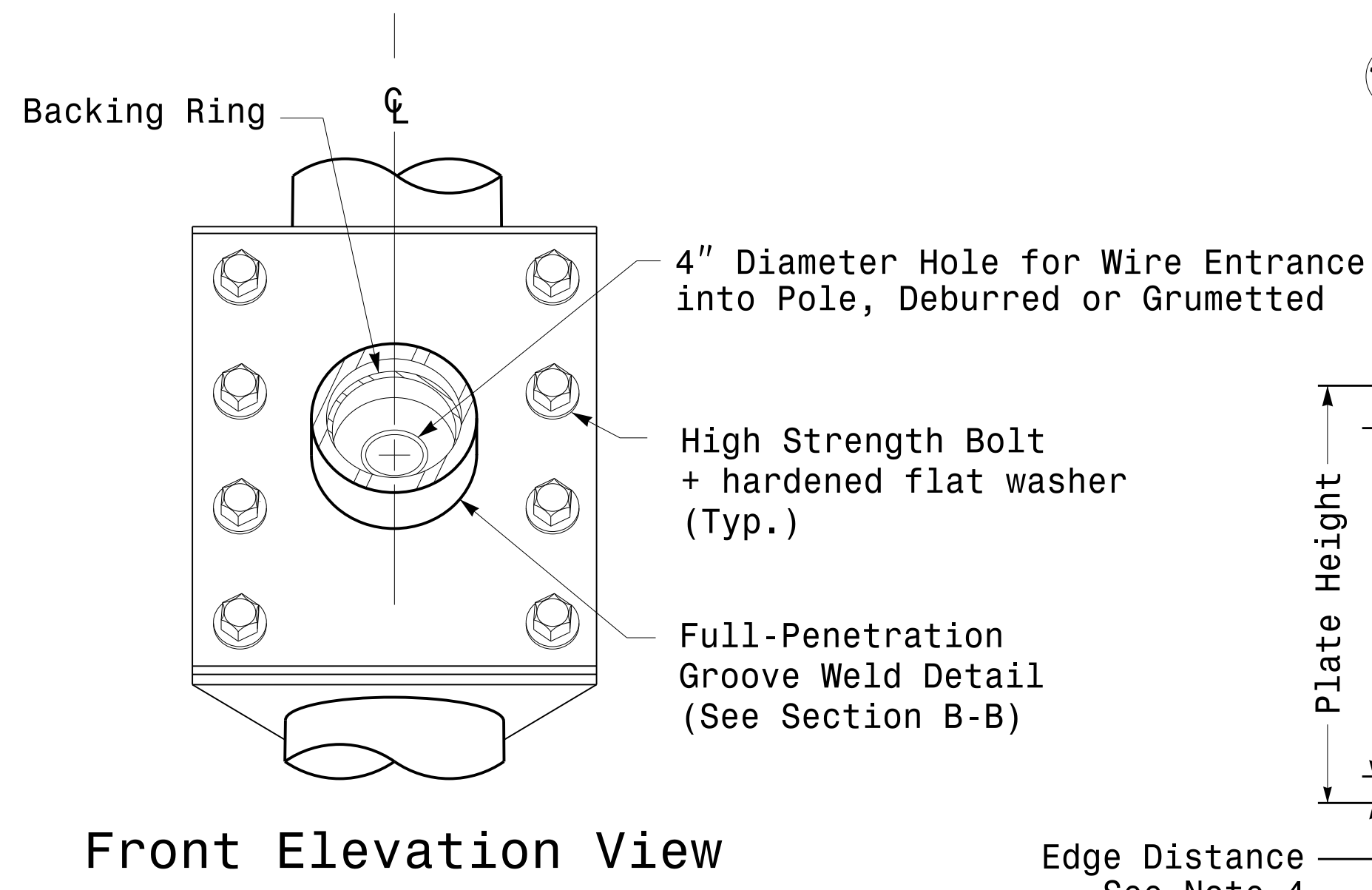
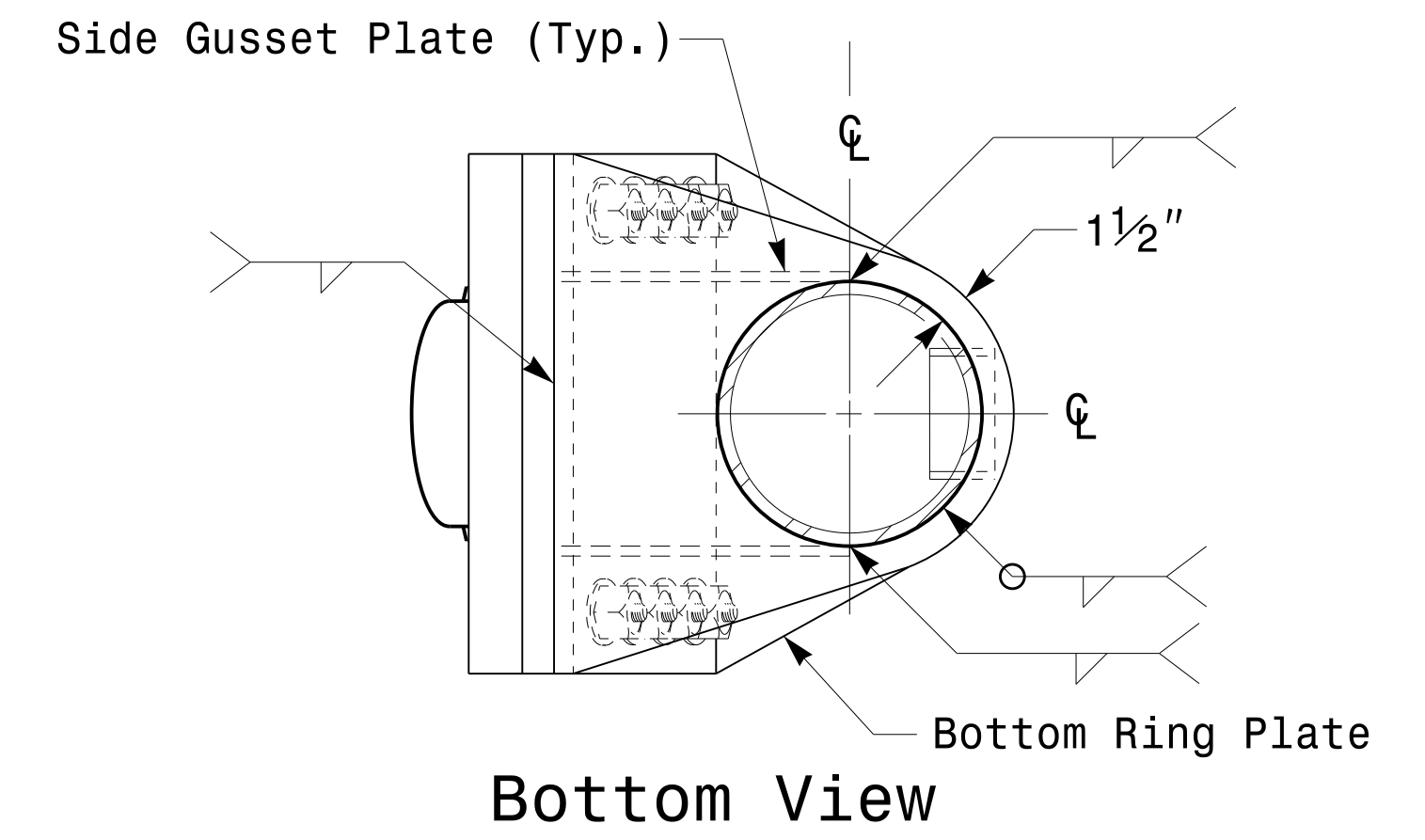
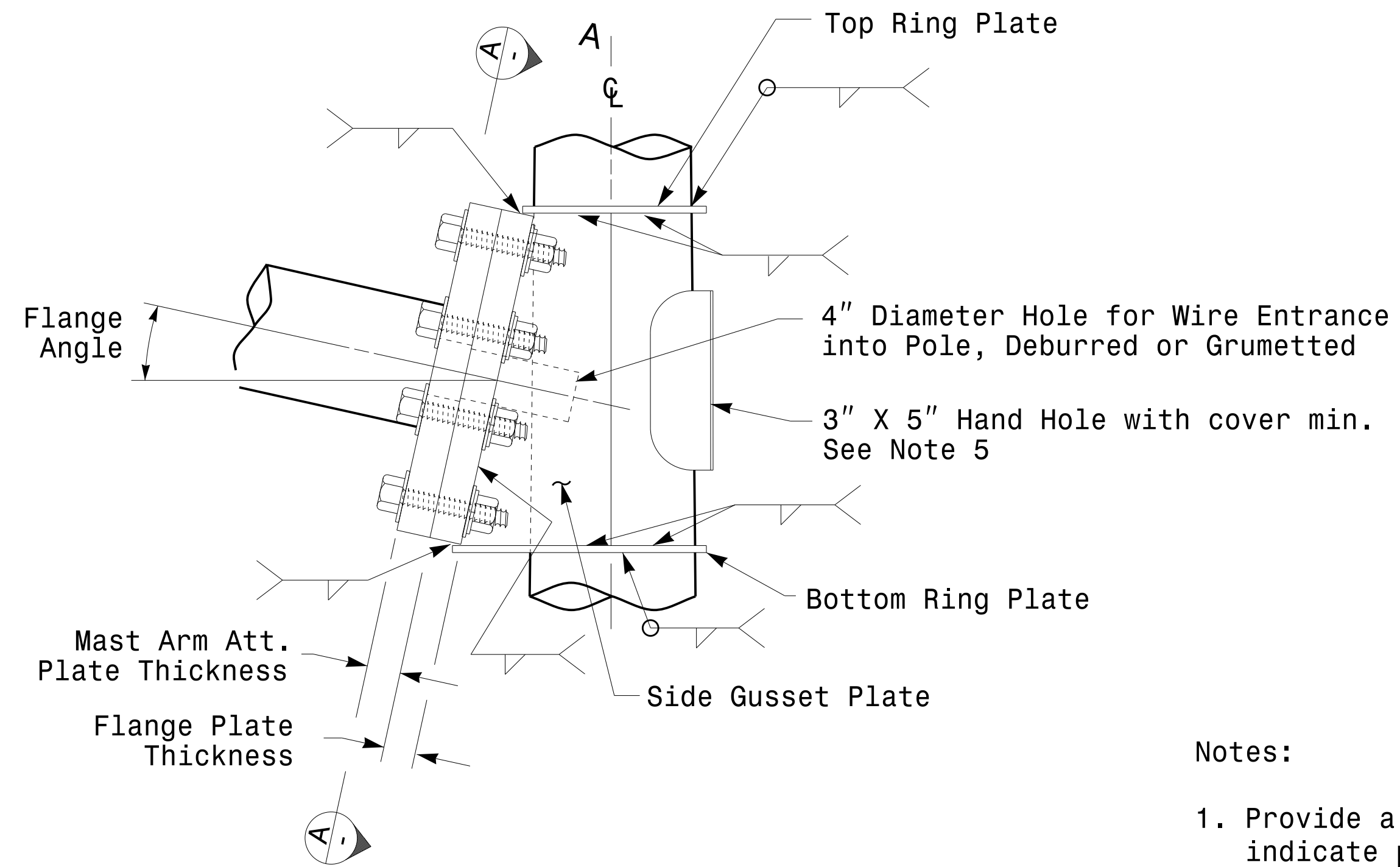
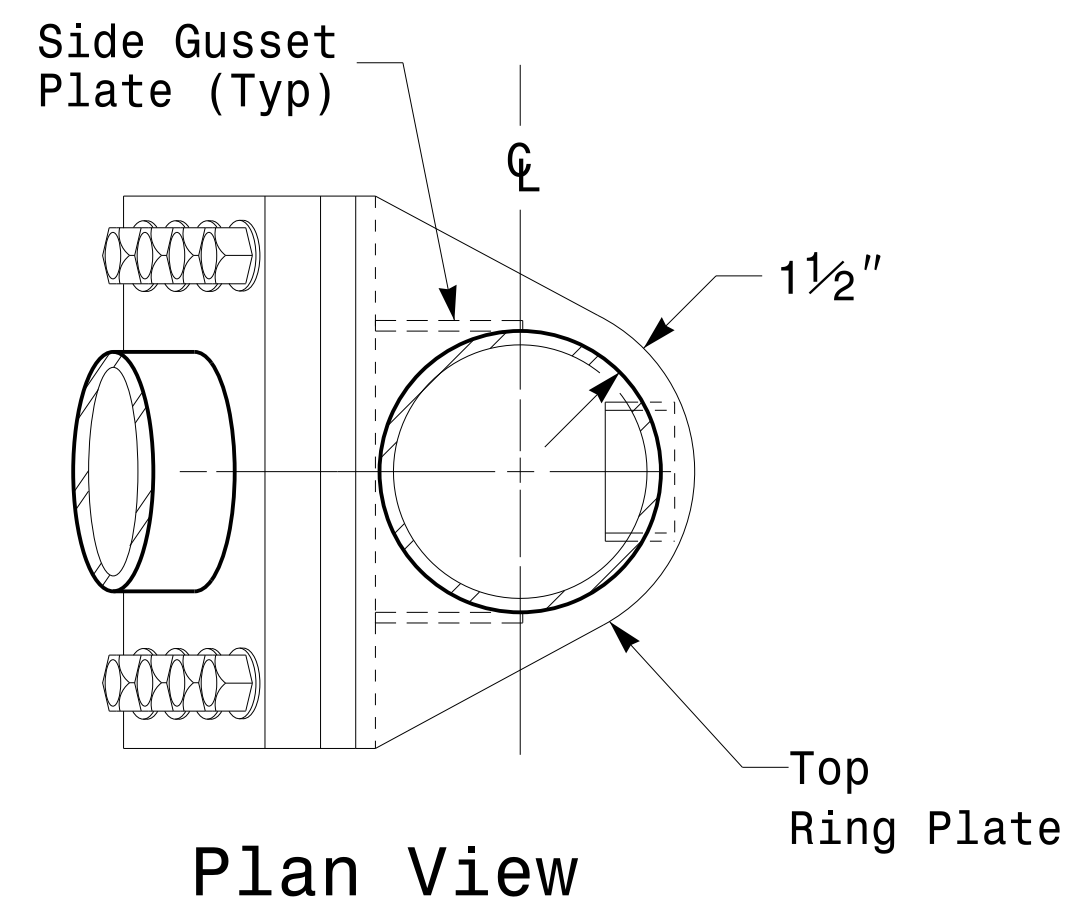

Notes:

1. Provide a permanent means of identification above the mast arm to indicate proper attachment orientation of the mast arm.
2. Designer will determine the size of all structural components, plates, fasteners, and welds shown unless they are already specified.
3. Fabricator is responsible for providing appropriate holes at drainage points to drain galvanizing materials.
4. For minimum edge distance follow AISC Table J3.4 and J3.5. For nominal bolt hole size use Table J3.3.
5. Provide upper handhole as necessary when shaft extensions are required for luminaire arms or camera. For poles without luminaires/camera, wiring can be done through the top of pole.
6. Allowable range of flange tilt angle will vary from 0° to as required.

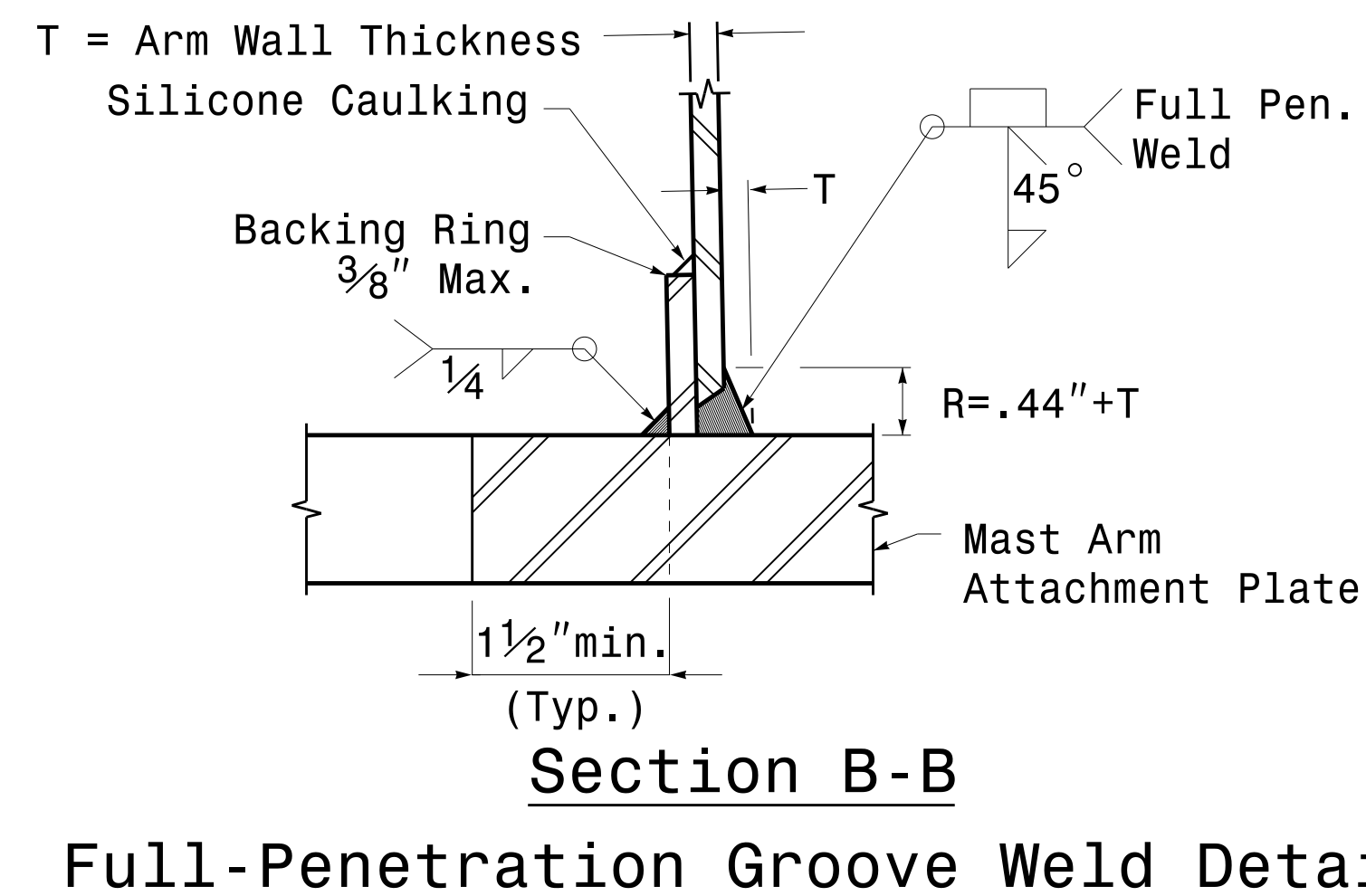
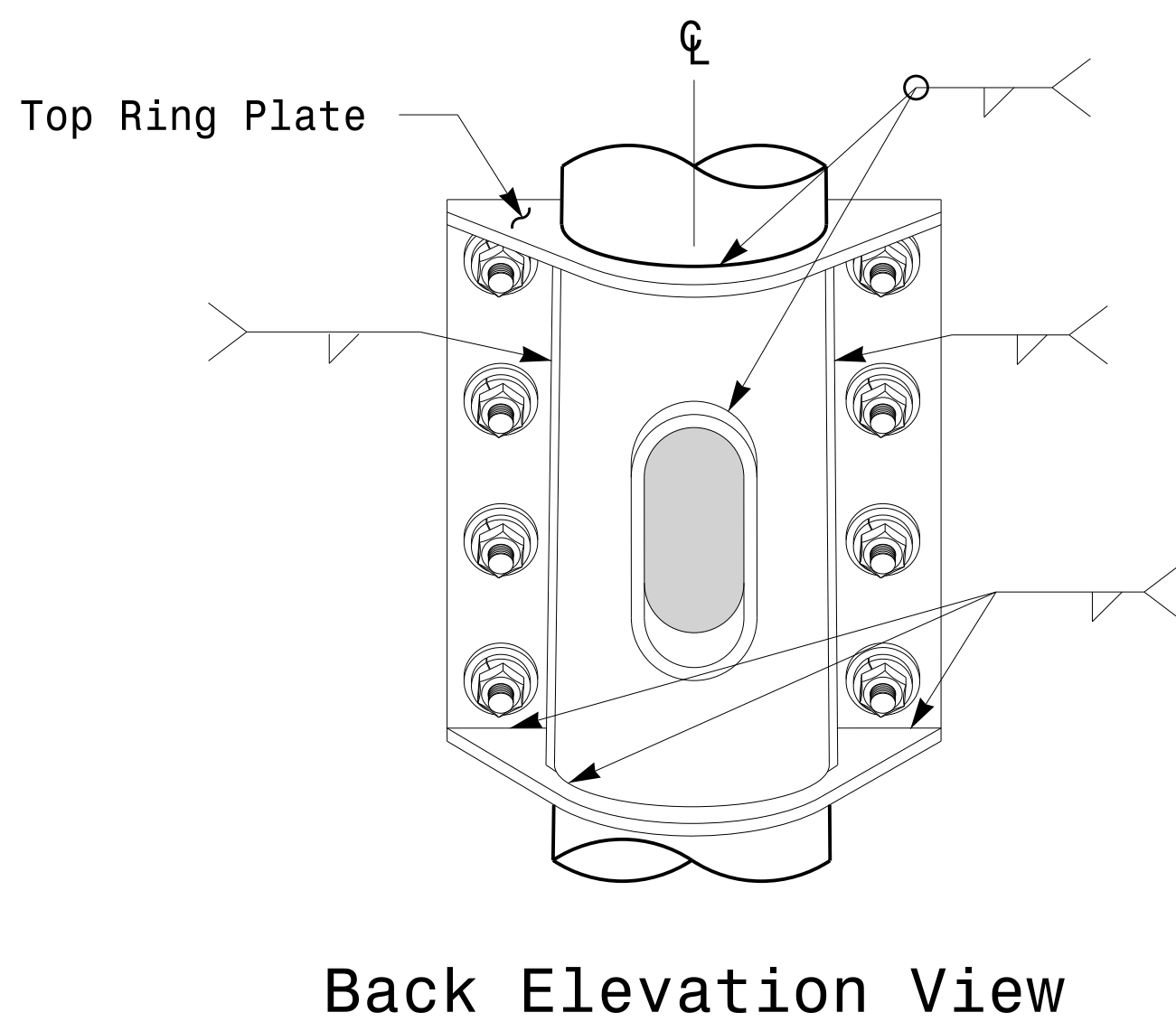

Prepared in the Offices of:

750 N. Greenfield Pkwy, Garner, NC 27529

SCALE: 0 NA NONE

Typical Fabrication Details For Mast Arm Connection To Pole

PLAN DATE: OCTOBER 2017	DESIGNED BY: C.F. ANDREWS
PREPARED BY: N. BITTING	REVIEWED BY: D.C. SARKAR
REVISIONS	INIT. DATE

SEAL

Discussed by: D.C. Sarkar

10/11/2017

DATE

11-OCT-2017 08:35:13 135604115 5101a1s451gnol Design Section Eastern Region\m4 Sheets\2016\2014 Sig.M5 51d - Connection Fabrication Detail\Mast Arm Poles.dgn

Fabrication Details - Mast Arm Connection

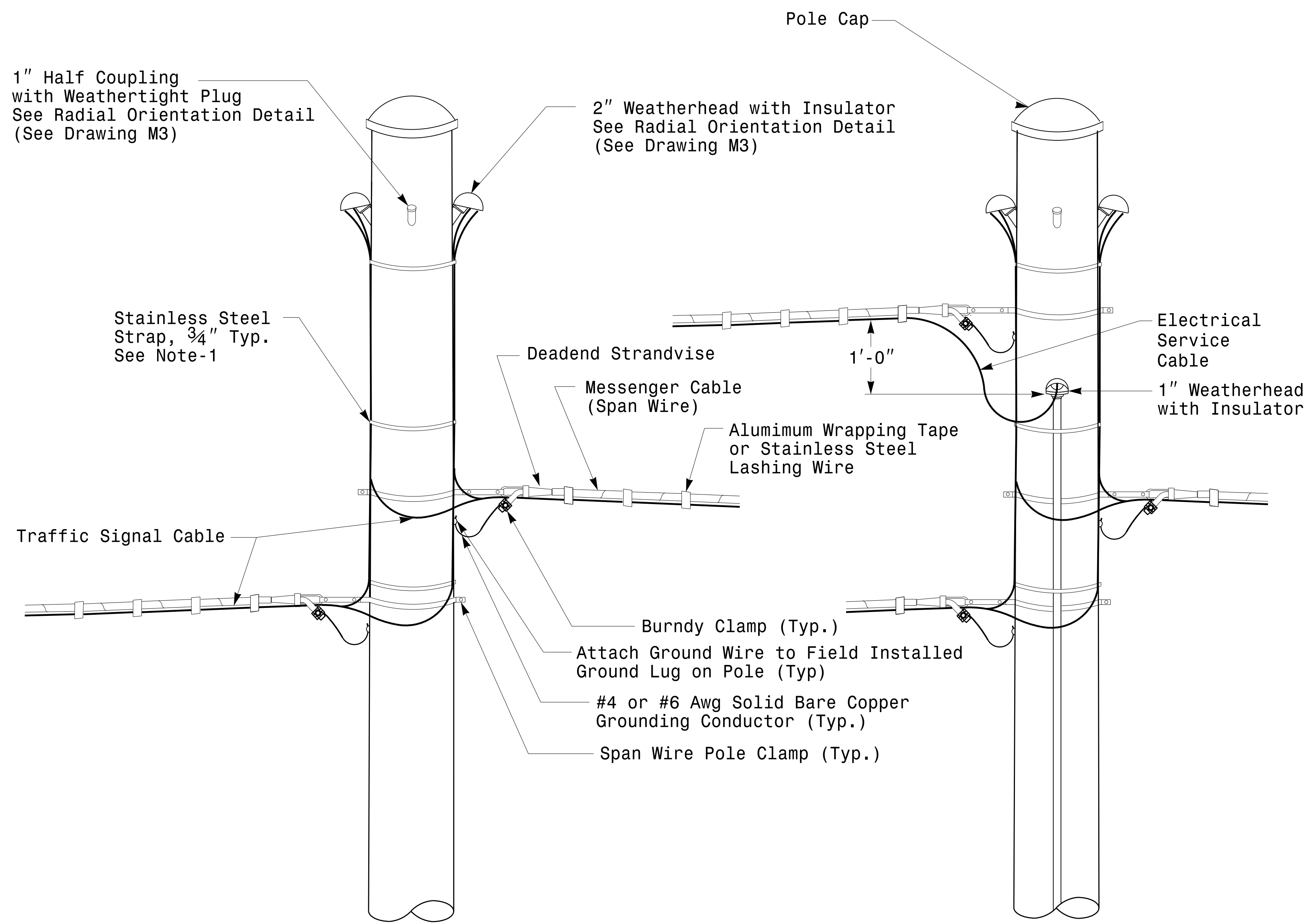

Strain Pole Attachments

NOTE:

1. Strap all signal cables to the side of the pole with 3/4" stainless steel straps when the distance between the spanwire attachment clamp and the weatherheads exceeds 3'-0".
2. Provide minimum two spanwire pole clamps per pole.
3. It is prohibited to attach two span wires at one pole clamp.
4. For general requirements refer to NCDOT Standard Specifications for Roadway and Structures, January 2018.

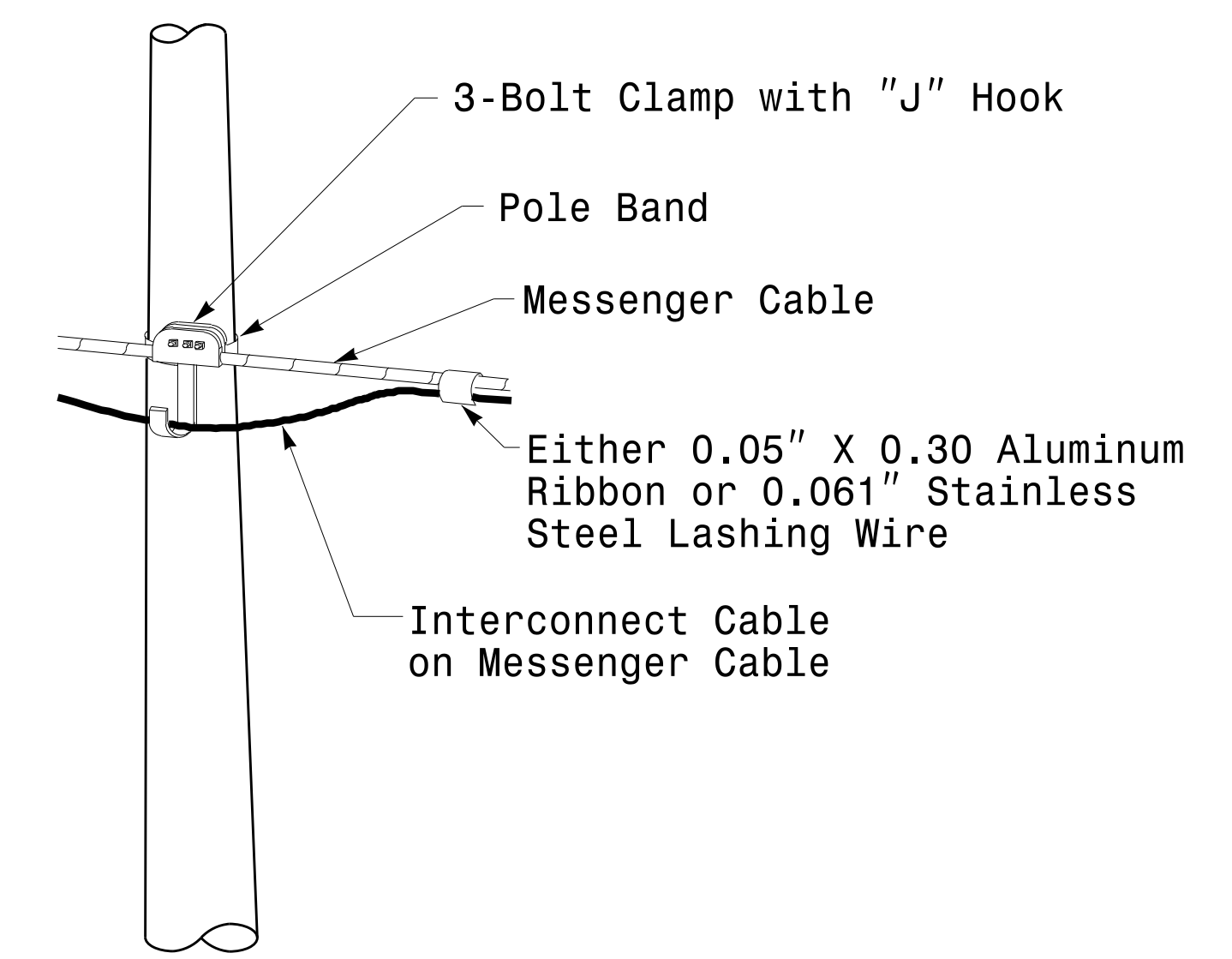

Attachment of Cable to Intermediate Metal Pole

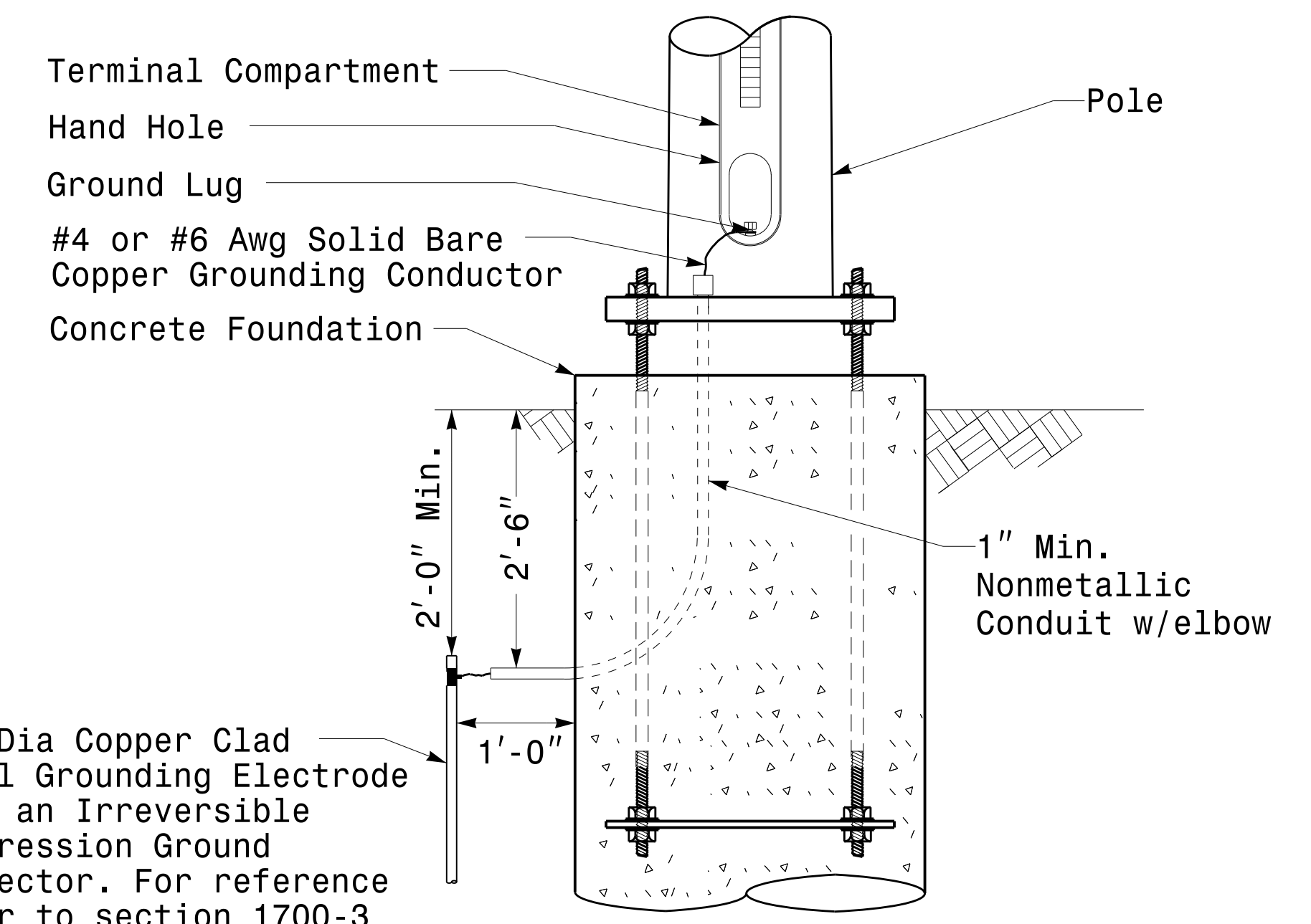

5/8" Dia Copper Clad Steel Grounding Electrode with an Irreversible Compression Ground Connector. For reference refer to section 1700-3 K and L for electrical grounding and bonding requirements, See Note 4.

Metal Pole Grounding Detail For Strain Pole and Mast Arm

	<p>Typical Fabrication Details For Strain Pole Attachments</p>		
	<p>PLAN DATE: OCTOBER 2017</p>	<p>DESIGNED BY: C.F. ANDREWS</p>	
<p>750 N. Greenfield Pkwy, Garner, NC 27529</p>	<p>SCALE: 0 NA NONE</p>	<p>REVISIONS</p>	<p>INIT. DATE</p>
<p>DocuSigned by: <i>Delishi C. Sarkar</i></p>			<p>10/11/2017</p>

11-0CT-2017-08136 11-05-2017 11:53:00 AM 115 Strain Pole Attachment Design Section Eastern Region 11/16/2014 Sig.M6 Std. Fabrication Details-Strain Poles.dgn

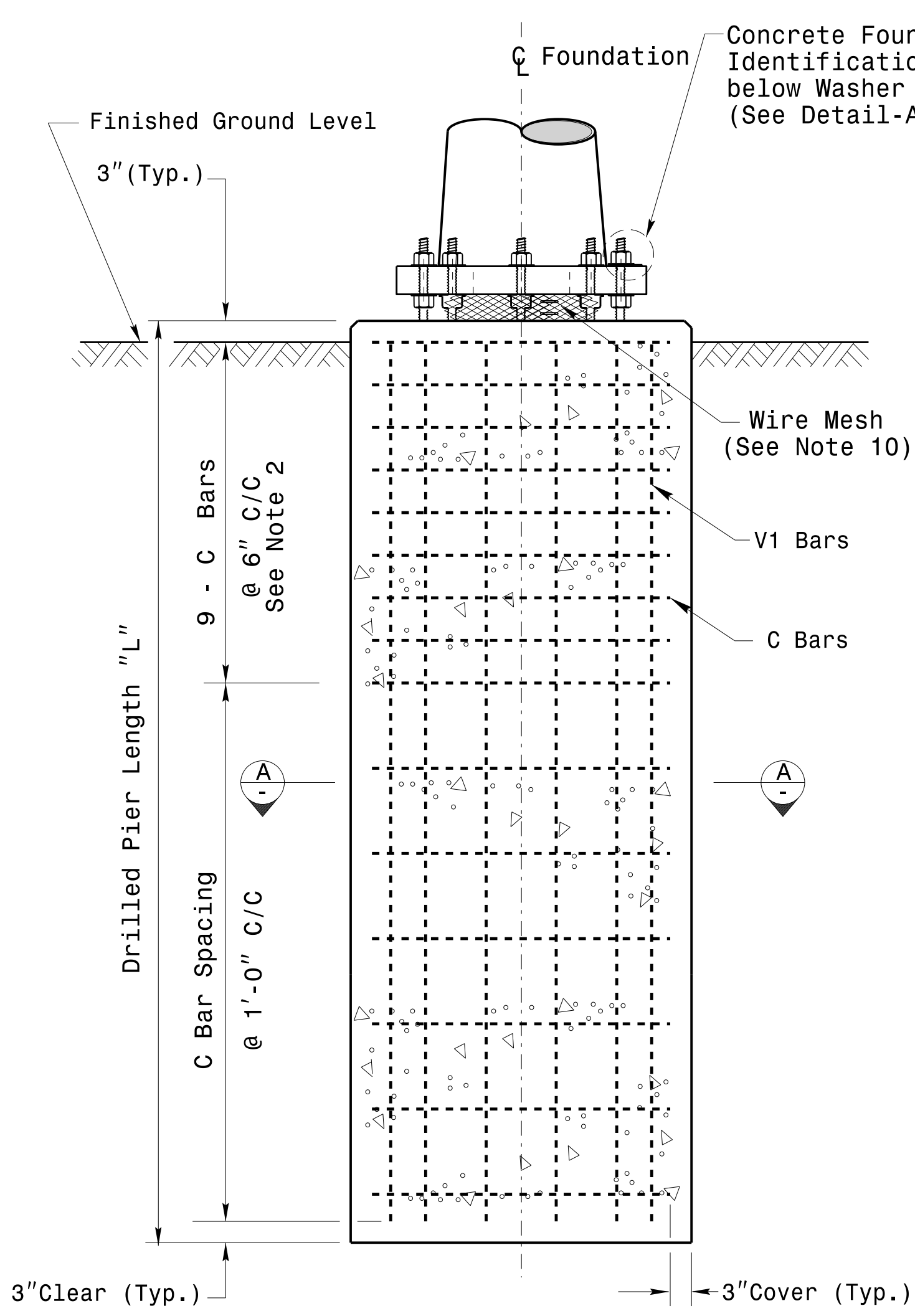

Concrete Shaft Elevation

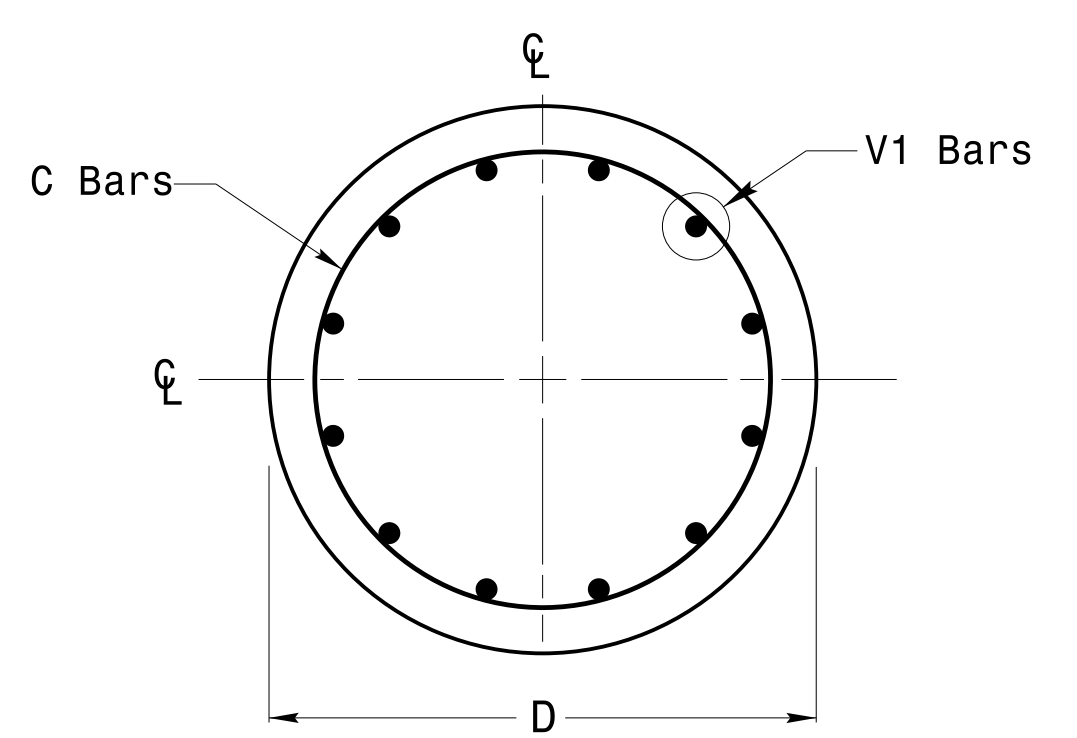

Section A-A

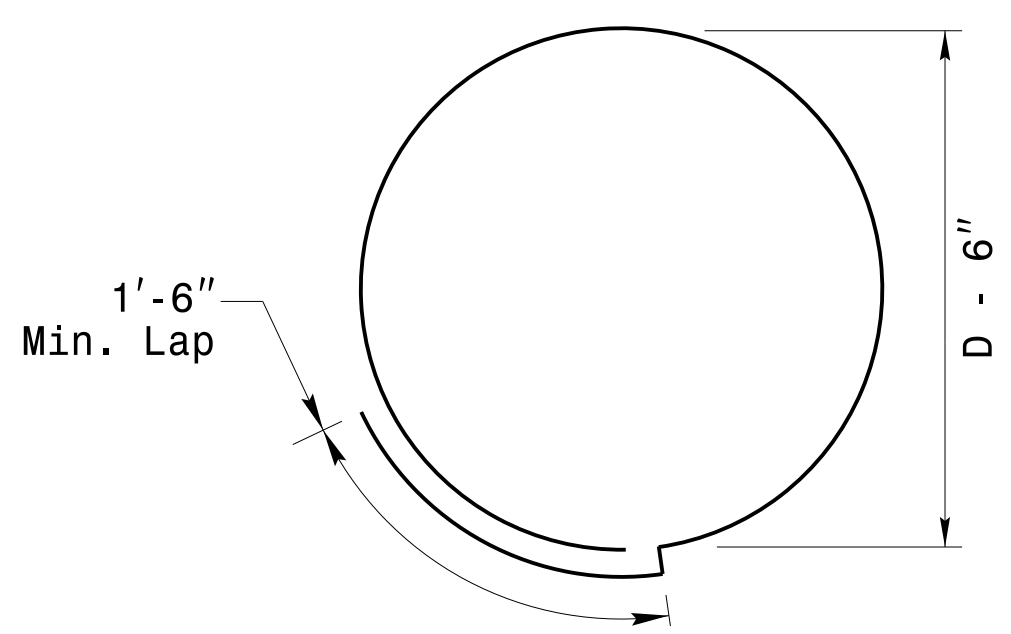

Typical "C" Bar Detail

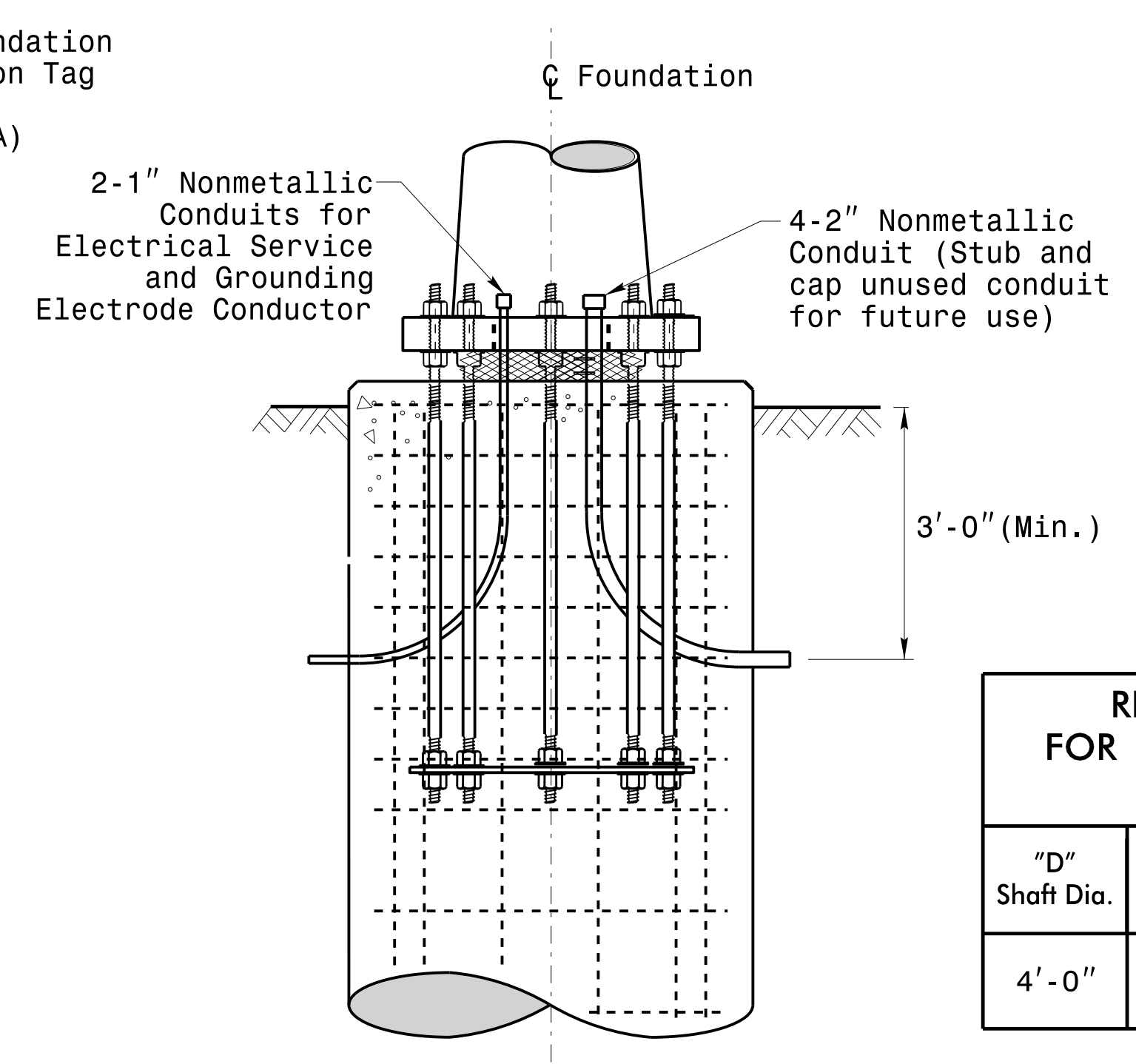

Typical Foundation Conduit Details

REINFORCING STEEL TABLE FOR STANDARD DRILL PIER SHAFT (4'-0" DIAMETER)

"D" Shaft Dia.	Conc. Volume (cu. yds.)	Bar Name	MIN.	Size	Type	Length
4'-0"	.465 x L	V1	—	#8	STR.	**
		C	*	#4	CIR.	12'-6"

* See Note No. 2
** See Note No. 3

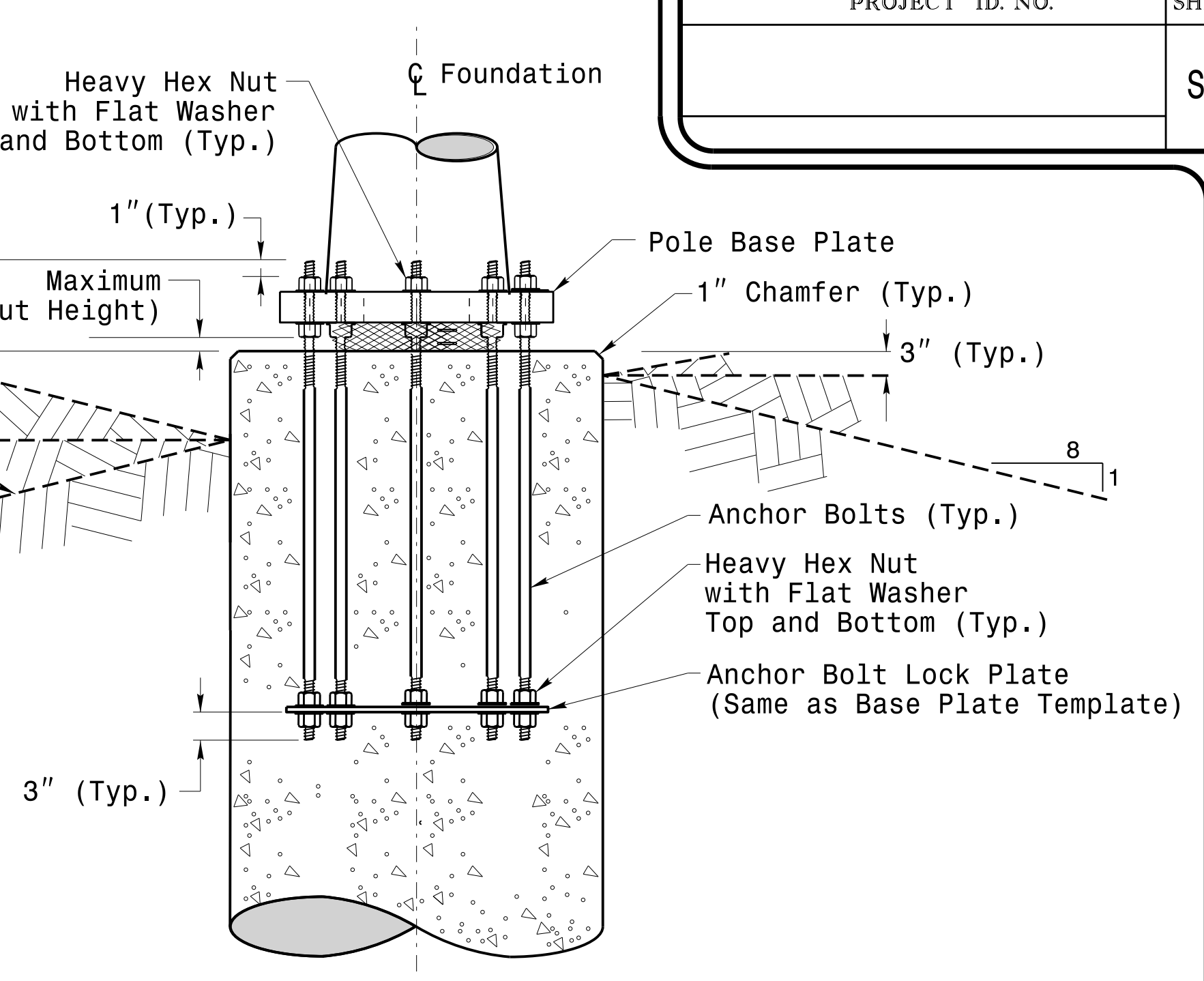

Typical Foundation Anchor Bolt Details

(Reinforcing Cage Not Shown for Clarity)

General Notes:

1. If actual subsurface conditions differ significantly from boring data contact the Engineer before excavating or placing concrete.
2. Circular tie reinforcing rings may be vertically adjusted by +/-3" at a depth between 2'-0" and 3'-0" to facilitate the installation of electrical conduit entering in the cage.
3. For standard foundations, see sheet Sig. M8 for details. Vertical reinforcing bars (V1) may be horizontally adjusted by +/-3" to facilitate the installation of electrical conduit entering into the cage.
4. Provide 2" to 5" foundation projection above ground level depending on the ground slope.
5. Unless otherwise shown, foundation designs are based on non-sloping level ground surfaces with slope ratios of 8:1 (H:V) or flatter. If actual ground line slopes are steeper contact the Engineer before excavating or placing concrete.
6. Construct foundations in accordance with NCDOT Standard Provisions SP09 R005- Foundations and Anchor Rod Assemblies for Metal Poles. All applicable 2018 NCDOT Standard Specifications are referenced in this provision. Refer to the NCDOT Resources/Specifications page located on the Connect NCDOT website.
[https://connect.ncdot.gov/resources/Specifications and Special Provisions.aspx](https://connect.ncdot.gov/resources/Specifications%20and%20Special%20Provisions.aspx)
7. Use air entrained AA concrete mix with a compression strength of f'c=4500 psi.(min.) after 28 days.
8. Use ASTM A615 grade 60 deformed bars for all reinforcing steel. Maintain at least 3" cover on all reinforcement.
9. Locate the Identification Tag on the top of the base plate, directly above the conduit's entry point.
10. Provide two layers of galvanized welded 23 gauge (0.25) 6" wide 4 mesh wire around pipes under the base plate and secure it with ties if necessary.
11. Preferred location for the I.D. Tag is as shown in Detail-A; directly above the conduit entering the foundation.

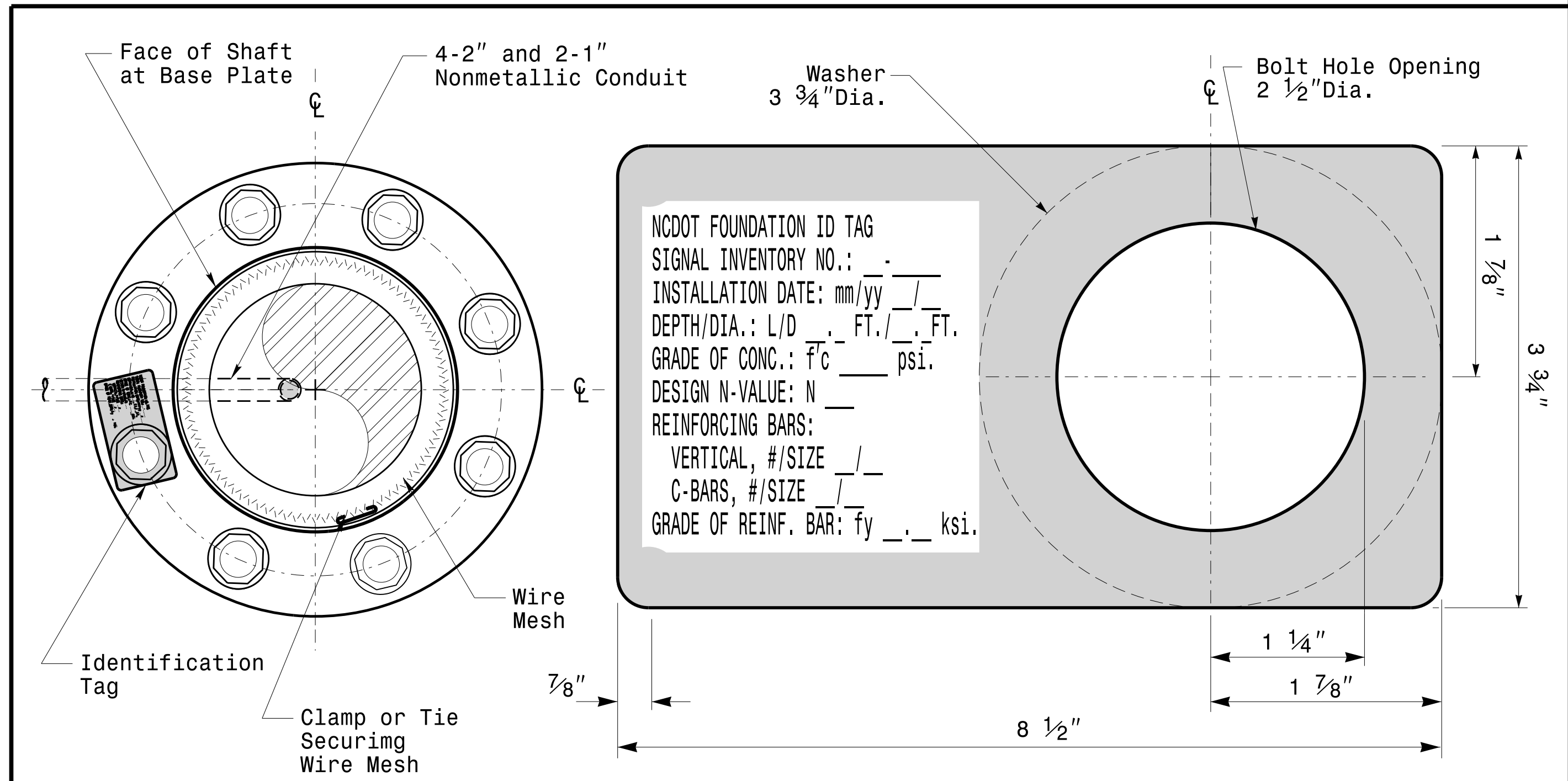

Concrete Foundation Identification Tag Details

Detail-A

D = Diameter
L = Length/Depth
mm = Month
yy = Year



Construction Details For Foundations

PLAN DATE:	OCTOBER 2018	DESIGNED BY:	C.B. COGDILL
PREPARED BY:	N. BITTING	REVIEWED BY:	D.C. SARKAR
REV. NO.	COMMENTS	INIT.	DATE
1	Revised Foundation Tag Details	N.B.	5/11/2015

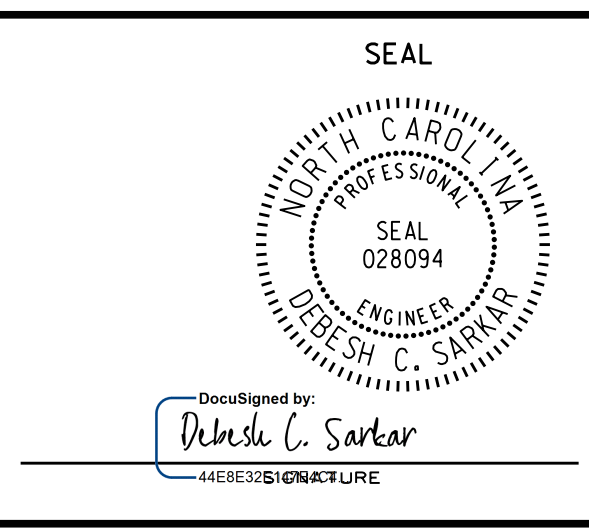

Construction Details – Foundations

11-0CT-2017-08:37:15:50W115:Signal:Design:Section:Eastern:Region:Sheet:2016:2014:Sig.M7:Std.:Construction:Detail:IS-Strain:Poles.dgn

SOIL CONDITION

		STANDARD STRAIN POLES					STANDARD FOUNDATIONS 48" Diameter Drilled Pier Length (L) - Feet							Reinforcement				
		Case No.	Pole Height (Ft.)	Base Plate BC (In.)	Reactions at the Pole Base			Clay				Sand			Longitudinal		Stirrups	
					Axial (kip)	Shear (kip)	Moment (ft-kip)	Medium N-Value 4-8	Stiff N-Value 9-15	Very Stiff N-Value 16-30	Hard N-Value >30	Loose N-Value 4-10	Medium N-Value 11-30	Dense N-Value >30	Bar Size (#)	Quantity (ea.)	Bar Size (#)	Spacing (in.)
WIND ZONE 1	LIGHT	S26L3	26	25	2	11	270	19	13	10	8	17	14.5	12.5	8	12	4	12
		S30L3	30	25	2	11	300	19.5	13.5	10	8	17.5	15	13	8	14	4	12
		S35L3	35	25	3	11	320	20	13.5	10.5	8	17.5	15	13	8	14	4	12
	HEAVY	S30H3	30	29	3	16	450	24.5	16	12	9	21	17.5	15	8	16	4	6
		S35H3	35	29	4	16	515	26	17	12.5	9.5	22	18.5	16	8	16	4	6
WIND ZONE 2	LIGHT	S26L2	26	23	2	10	245	18	12.5	9.5	8	16.5	14	12	8	12	4	12
		S30L2	30	23	2	10	270	18.5	12.5	10	8	16.5	14	12.5	8	12	4	12
		S35L2	35	23	3	10	300	19.5	13	10	8	17	14.5	13	8	12	4	12
	HEAVY	S30H2	30	29	3	15	415	23	15.5	11.5	9	20	17	14.5	8	16	4	6
		S35H2	35	29	4	15	475	25	16.5	12	9.5	21	17.5	15.5	8	16	4	6
WIND ZONE 3	LIGHT	S26L2	26	23	2	10	245	18	12.5	9.5	8	16.5	14	12	8	12	4	12
		S30L2	30	23	2	10	270	18.5	12.5	10	8	16.5	14	12.5	8	12	4	12
		S35L2	35	23	3	10	300	19.5	13	10	8	17	14.5	13	8	12	4	12
	HEAVY	S30H2	30	29	3	15	415	23	15.5	11.5	9	20	17	14.5	8	16	4	6
		S35H2	35	29	4	15	475	25	16.5	12	9.5	21	17.5	15.5	8	16	4	6
WIND ZONE 4	LIGHT	S26L1	26	22	2	8	190	16	11.5	8.5	8	15	12.5	11	8	12	4	12
		S30L1	30	22	2	8	205	16.5	11.5	9	8	15	13	11.5	8	12	4	12
		S35L1	35	22	3	8	230	17	12	9	8	15.5	13.5	11.5	8	12	4	12
	HEAVY	S30H1	30	25	3	12	320	20.5	13.5	10.5	8	18	15	13.5	8	16	4	6
		S35H1	35	25	4	12	350	21	14	10.5	8.5	18.5	15.5	13.5	8	16	4	6
WIND ZONE 5	LIGHT	S26L2	26	23	2	10	245	18	12.5	9.5	8	16.5	14	12	8	12	4	12
		S30L2	30	23	2	10	270	18.5	12.5	10	8	16.5	14	12.5	8	12	4	12
		S35L2	35	23	3	10	300	19.5	13	10	8	17	14.5	13	8	12	4	12
	HEAVY	S30H2	30	29	3	15	415	23	15.5	11.5	9	20	17	14.5	8	16	4	6
		S35H2	35	29	4	15	475	25	16.5	12	9.5	21	17.5	15.5	8	16	4	6

General Notes:



1. Values shown in the "Reactions at the Pole Base" column represent the minimum acceptable capacity allowed for design using a design CSR of 1.00.
2. Use chairs and spacers to maintain proper clearance.
3. For foundation, always use air-entrain concrete mix.

Foundation Selection:

1. Perform a standard penetration test at each proposed foundation site to determine "N" value.
2. Select the appropriate wind zone from M 1 drawing.
3. Select the soil type (Clay or Sand) that best describes the soil characteristics.
4. Get the appropriate standard pole case number from the plans or from the Engineer.
5. Select the appropriate column under "Standard Foundations" based on soil type and "N" value. Select the appropriate row based on the pole load case.
6. The foundation depth is the value shown in the "Standard Foundations" category where the column and the row intersect.
7. Use Construction Procedures and Design Methods prescribed by FHWA-NHI-10-016 for Reference Drilled Shafts.

Standard Strain Pole Foundation-All Soil Condition

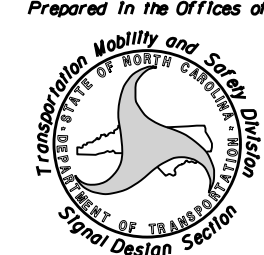
48" Dia. Foundations Concrete Volume (cubic yards) = (0.465) x Drilled Pier Length

	<p>Standard Strain Pole Foundation for All Soil Conditions</p> <p>PLAN DATE: OCTOBER 2017 DESIGNED BY: C.B. COGDILL PREPARED BY: N. BITTING REVIEWED BY: D.C. SARKAR</p>							
SCALE: 0 NA NONE	REVISIONS: <table border="1" style="font-size: small;"> <tr> <th>NO.</th> <th>DATE</th> <th>INIT.</th> </tr> <tr> <td>1</td> <td>7/12/2015</td> <td>N.B.</td> </tr> </table> <p>Changed "Foundation Depth" to "Drilled Pier Length" in Conc. Egn.</p>	NO.	DATE	INIT.	1	7/12/2015	N.B.	Documented by: <i>D. C. SARKAR</i> DATE: 10/11/2017
NO.	DATE	INIT.						
1	7/12/2015	N.B.						

I:\Projects\2017_08-10_Sig.M8\15_Sig.M8_Std_Strain Pole Found.-Saturated Soil_Condition.dgn Sheets\2016\2014_Sig.M8_Std_Strain Pole Found.-Saturated Soil_Condition.dgn