

**This electronic collection of documents is provided  
for the convenience of the user  
and is Not a Certified Document –**

**The documents contained herein were originally issued  
and sealed by the individuals whose names and license  
numbers appear on each page, on the dates appearing  
with their signature on that page.**

**This file or an individual page  
shall not be considered a certified document.**



**LOCATION SKETCH**

**BRIDGE COORDINATES**

BRIDGE No.	LATITUDE	LONGITUDE
280146	35°-46'-26.06"	80°-18'-51.80"

**TOTAL BILL OF MATERIAL**

BRIDGE NO.	POLLUTION CONTROL	CONCRETE REPAIRS	SHOTCRETE REPAIRS	EPOXY RESIN INJECTION	CLEANING & REPAINTING OF BRIDGE NO. 280146	PAINTING CONTAINMENT FOR BRIDGE NO. 280146	CONCRETE REPAIRS (CLASS B)	EPOXY COATING
280146								
	LUMP SUM	CU. FT.	CU. FT.	LIN. FT.	LUMP SUM	LUMP SUM	CU. FT.	SQ. FT.
TOTAL	LUMP SUM	11.5	231.5	13.5	LUMP SUM	LUMP SUM	2.7	565.0

**NOTES**

INFORMATION INDICATED ON THE LOCATION SKETCH SHALL BE CONSIDERED GENERAL INFORMATION ONLY. THE CONTRACTOR SHALL CONFIRM, THROUGH OTHER SOURCES, SPECIFIC INFORMATION REGARDING BRIDGES, ROADWAYS, UTILITIES, THE SURROUNDING AREA, AND ANY OTHER ASPECTS THAT MAY BE NECESSARY TO PERFORM AND COMPLETE THE PROJECT.

EXISTING DIMENSIONS AND BRIDGE CONDITION ARE FROM THE BEST INFORMATION AVAILABLE. THE CONTRACTOR SHALL FIELD VERIFY THE INFORMATION SHOWN ON THE PLANS AND NOTIFY THE ENGINEER IF ACTUAL DIMENSIONS AND CONDITIONS DIFFER.

THE CONTRACTOR SHALL HAVE NO CLAIM WHATSOEVER AGAINST THE DEPARTMENT FOR ANY DELAYS OF ADDITIONAL COST INCURRED BASED ON DIFFERENCES BETWEEN WHAT IS SHOWN ON THE PLANS AND THE ACTUAL CONDITIONS AT THE PROJECT SITE.

IT IS THE CONTRACTOR'S RESPONSIBILITY TO FOLLOW ALL STATE AND FEDERAL SAFETY REQUIREMENTS.

FOR CONTROL OF TRAFFIC AND LIMITS ON PHASING OF CONSTRUCTION, SEE TRANSPORTATION MANAGEMENT PLANS.

FOR EPOXY RESIN INJECTIONS, SEE SPECIAL PROVISIONS.

FOR CONCRETE REPAIRS AND CONCRETE REPAIRS (CLASS B), SEE SPECIAL PROVISIONS.

FOR SHOTCRETE REPAIRS, SEE SPECIAL PROVISIONS.

THE CONTRACTOR SHALL PROVIDE INDEPENDENT ASSURANCE SAMPLES OF REINFORCING STEEL AS FOLLOWS: FOR PROJECTS REQUIRING UP TO 400 TONS OF REINFORCING STEEL, ONE 30 INCH SAMPLE OF EACH SIZE BAR USED, AND FOR PROJECTS REQUIRING OVER 400 TONS OF REINFORCING STEEL, TWO 30 INCH SAMPLES OF EACH SIZE BAR USED. THE SAMPLE BARS SHOULD COME FROM STEEL ACTUALLY USED IN THE PROJECT AND THE SAMPLE BARS SHOULD BE REPLACED BY SPLICED BARS AS SPECIFIED IN THE SAMPLE BAR REPLACEMENT CHART. PAYMENT FOR THE SAMPLE BARS AND REPLACEMENT REINFORCING STEEL SHALL BE CONSIDERED INCIDENTAL TO VARIOUS PAY ITEMS.

FOR PAINTING CONTAINMENT, POLLUTION CONTROL AND CLEANING & REPAINTING BRIDGE, SEE SPECIAL PROVISIONS.

FOR ANCHOR BOLT NUT REPLACEMENT AND TIGHTENING, SEE SPECIAL PROVISIONS.

FOR SUBMITTAL OF WORKING DRAWINGS, SEE SPECIAL PROVISIONS.

FOR FALSEWORK AND FORMWORK, SEE SPECIAL PROVISIONS.

FOR CRANE SAFETY, SEE SPECIAL PROVISIONS.

FOR GROUT FOR STRUCTURES, SEE SPECIAL PROVISIONS.

FOR EPOXY COATING AND DEBRIS REMOVAL, SEE SPECIAL PROVISIONS.

ANY DAMAGE TO EXISTING REINFORCING STEEL, DURING CONTRACTOR'S OPERATIONS, SHALL BE REPAIRED AS DIRECTED BY THE ENGINEER AND PERFORMED AT NO ADDITIONAL COST TO THE DEPARTMENT.

SHOTCRETE REPAIRS MAY BE REPLACED WITH CONCRETE REPAIRS WITH THE APPROVAL OF THE ENGINEER.

WORK ON THE BRIDGE SHALL BE PERFORMED SO AS NOT TO ALLOW DEBRIS TO FALL BELOW, EXCEPT WHERE THE CONTRACTOR'S PLAN USE PLATFORMS, NETS, SCREENS OR OTHER PROTECTIVE DEVICES TO CATCH THE MATERIAL. THE CONTRACTOR SHALL SUBMIT PLANS FOR CONSTRUCTION IN ACCORDANCE WITH ARTICLE 402-2 OF THE STANDARD SPECIFICATIONS AND THE PROJECT SPECIAL PROVISIONS.

PRIOR TO BEGINNING WORK, THE CONTRACTOR SHALL SUBMIT FOR REVIEW AND APPROVAL A COMPLETE SEQUENCE OF TASKS FOR EACH OPERATION AFFECTING THE BRIDGE SURFACE AND/OR TRAFFIC.

THE CONTRACTOR SHALL PERFORM ALL WORK WITH CARE SO THAT THE EXISTING STRUCTURE WHICH IS TO REMAIN IN PLACE WILL NOT BE DAMAGED. IF THE CONTRACTOR DAMAGES ANY PART OF THE EXISTING STRUCTURE WHICH IS TO REMAIN IN PLACE, THE DAMAGED AREA SHALL BE REPAIRED OR REPLACED IN A MANNER SATISFACTORY TO THE ENGINEER AT NO ADDITIONAL COST TO THE DEPARTMENT.

PROJECT NO. **I-5950**

**DAVIDSON** COUNTY

BRIDGE NO. **280146**

SHEET 2 OF 2

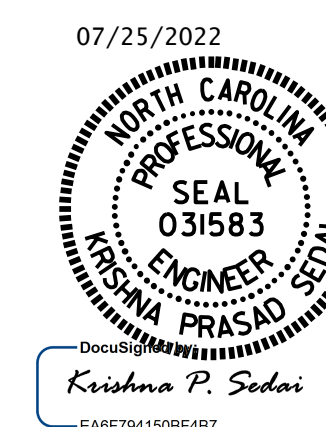

STATE OF NORTH CAROLINA  
DEPARTMENT OF TRANSPORTATION  
RALEIGH

**GENERAL DRAWING  
FOR BRIDGE ON  
NC47 OVER  
I-85**

DOCUMENT NOT CONSIDERED FINAL UNLESS ALL SIGNATURES COMPLETED

REVISIONS						SHEET NO.
NO.	BY:	DATE:	NO.	BY:	DATE:	S3-02
1			3			TOTAL SHEETS 15
2			4			

DRAWN BY : E. BAYISSA DATE : 03/2022  
CHECKED BY : A. SORSENGINH DATE : 05/2022

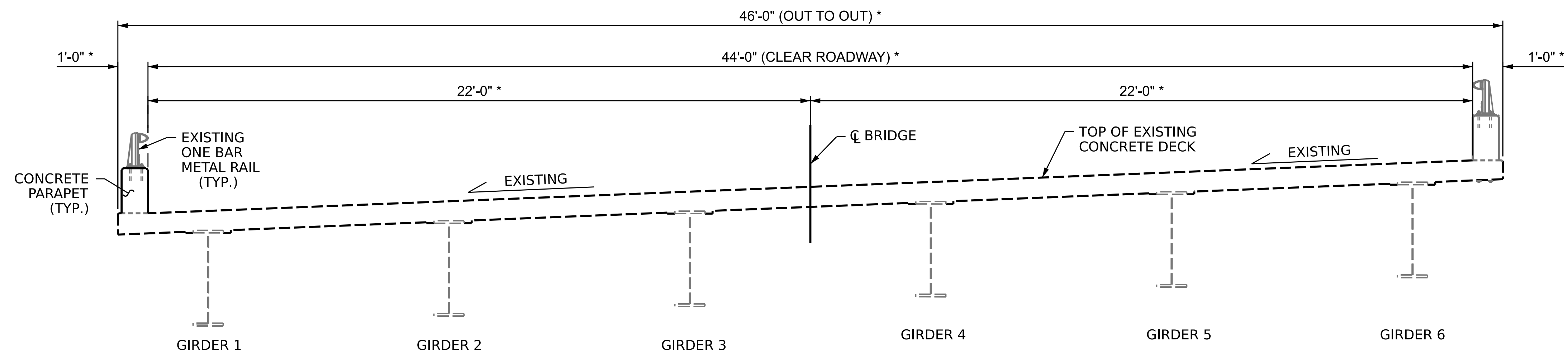

**TYPICAL SECTION**  
(EXISTING)  
\* RADIAL DIMENSION

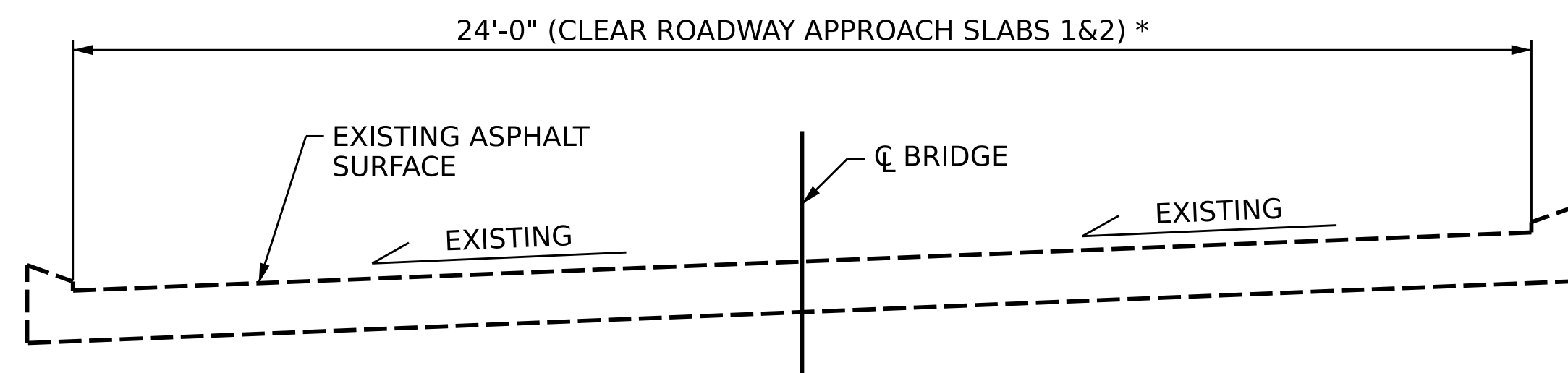

**TYPICAL SECTION - APPROACH SLAB**  
(EXISTING)  
\* RADIAL DIMENSION

PROJECT NO. **I-5950**  
**DAVIDSON** COUNTY  
 BRIDGE NO. **280146**

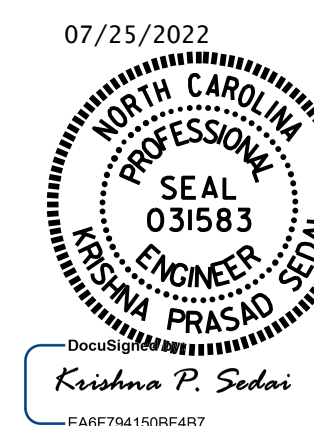

STATE OF NORTH CAROLINA  
 DEPARTMENT OF TRANSPORTATION  
 RALEIGH

**TYPICAL SECTION**

REVISIONS						SHEET NO.
NO.	BY:	DATE:	NO.	BY:	DATE:	S3-03
1			3			TOTAL SHEETS
2			4			15

DOCUMENT NOT CONSIDERED  
 FINAL UNLESS ALL  
 SIGNATURES COMPLETED

DRAWN BY : E. BAYISSA DATE : 03/2022  
 CHECKED BY : A. SORSENGINH DATE : 05/2022

### AS-BUILT REPAIR QUANTITY TABLE

DECK UNDERSIDE REPAIRS SPAN A	QUANTITIES			
	ESTIMATE		ACTUAL	
SHOTCRETE REPAIRS	AREA SF	VOLUME CF	AREA SF	VOLUME CF
UNDERSIDE OF DECK	0	0		
BENT DIAPHRAGM	23.4	11.7		
OVERHANG	0	0		

VALUES IN CHART REPRESENT ESTIMATED REPAIR TOTALS AFTER REMOVAL OF UNSOUND CONCRETE, MIN. OF 1" BEHIND REBAR AND MIN. 2" CLEAR TO SAWCUT. SEE REPAIR DETAILS.

#### NOTES

REPAIR LOCATIONS AND ESTIMATE OF QUANTITIES ARE GIVEN BASED ON THE BEST INFORMATION AVAILABLE. IF ADDITIONAL REPAIRS NOT SHOWN ON THE DRAWINGS ARE DEEMED NECESSARY BY THE ENGINEER, THE ENGINEER SHALL NOTE ON THE DRAWINGS THE APPROXIMATE LOCATION AND DESCRIPTION OF THE REPAIRS AND ENTER THE ACTUAL QUANTITIES INTO THE AS-BUILT REPAIR QUANTITY TABLE.

THE CONTRACTOR SHALL SAW CUT TO A NOMINAL DEPTH OF 1/2" BUT REINFORCING STEEL SHALL NOT BE DAMAGED.

CONTRACTOR SHALL REMOVE SURFACE CONCRETE TO VERIFY THAT SAWCUT DEPTH WILL NOT DAMAGE EXISTING REINFORCING STEEL.

SHOTCRETE REPAIRS MAYBE SUBSTITUTED IN LIEU OF CONCRETE REPAIRS WITH THE APPROVAL OF THE ENGINEER.

FOR UNDERSIDE DECK REPAIR, SEE "OVERHANG, DIAPHRAGM AND BRIDGE RAIL REPAIR DETAILS" SHEET.

FOR SHOTCRETE REPAIRS, SEE SPECIAL PROVISIONS.

FOR CONCRETE REPAIRS, SEE SPECIAL PROVISIONS.

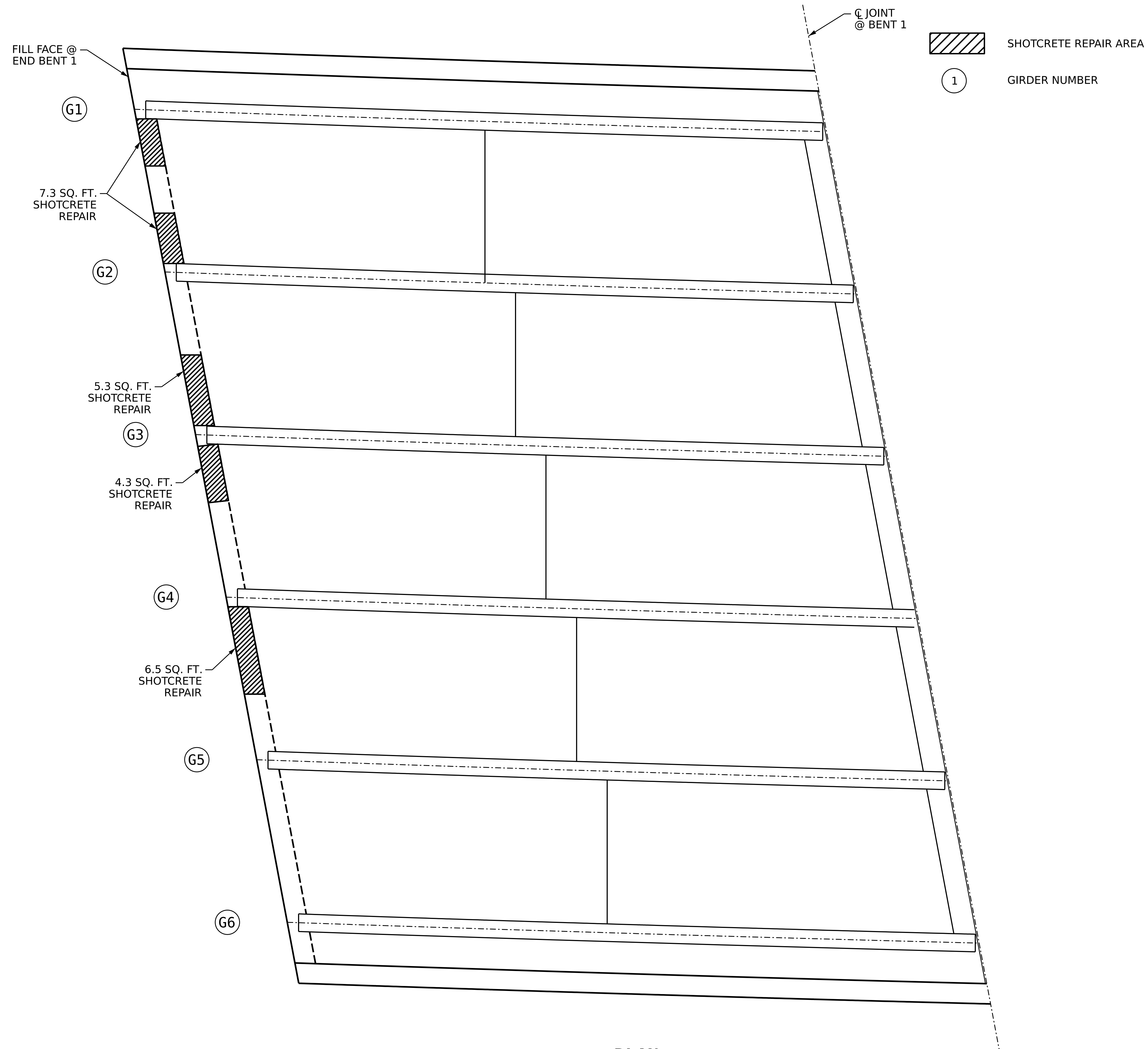

### PLAN

PROJECT NO. I-5950  
DAVIDSON COUNTY  
 BRIDGE NO. 280146

SHEET 1 OF 4

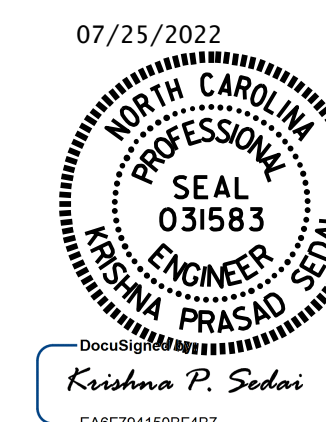

STATE OF NORTH CAROLINA  
 DEPARTMENT OF TRANSPORTATION  
 RALEIGH

### DECK UNDERSIDE REPAIR SPAN A

REVISIONS						SHEET NO. S3-04
NO.	BY:	DATE:	NO.	BY:	DATE:	
1			3			TOTAL SHEETS 15
2			4			

DOCUMENT NOT CONSIDERED  
 FINAL UNLESS ALL  
 SIGNATURES COMPLETED

DRAWN BY : E. BAYISSA DATE : 04/2022  
 CHECKED BY : A. SORSENGINH DATE : 05/2022

### AS-BUILT REPAIR QUANTITY TABLE

DECK UNDERSIDE REPAIRS SPAN B	QUANTITIES			
	ESTIMATE		ACTUAL	
SHOTCRETE REPAIRS	AREA SF	VOLUME CF	AREA SF	VOLUME CF
UNDERSIDE OF DECK	0	0		
BENT DIAPHRAGM	32.9	16.5		
OVERHANG	6.0	2.0		

VALUES IN CHART REPRESENT ESTIMATED REPAIR TOTALS AFTER REMOVAL OF UNSOUND CONCRETE, MIN. OF 1" BEHIND REBAR AND MIN. 2" CLEAR TO SAWCUT. SEE REPAIR DETAILS.

#### NOTES

REPAIR LOCATIONS AND ESTIMATE OF QUANTITIES ARE GIVEN BASED ON THE BEST INFORMATION AVAILABLE. IF ADDITIONAL REPAIRS NOT SHOWN ON THE DRAWINGS ARE DEEMED NECESSARY BY THE ENGINEER, THE ENGINEER SHALL NOTE ON THE DRAWINGS THE APPROXIMATE LOCATION AND DESCRIPTION OF THE REPAIRS AND ENTER THE ACTUAL QUANTITIES INTO THE AS-BUILT REPAIR QUANTITY TABLE.

THE CONTRACTOR SHALL SAW CUT TO A NOMINAL DEPTH OF 1/2" BUT REINFORCING STEEL SHALL NOT BE DAMAGED.

THE CONTRACTOR SHALL REMOVE SURFACE CONCRETE TO VERIFY THAT SAWCUT DEPTH WILL NOT DAMAGE EXISTING REINFORCING STEEL.

SHOTCRETE REPAIRS MAYBE SUBSTITUTED IN LIEU OF CONCRETE REPAIRS WITH THE APPROVAL OF THE ENGINEER.

FOR UNDERSIDE DECK REPAIR, SEE "OVERHANG, DIAPHRAGM AND BRIDGE RAIL REPAIR DETAILS" SHEET.

FOR SHOTCRETE REPAIRS, SEE SPECIAL PROVISIONS.

FOR CONCRETE REPAIRS, SEE SPECIAL PROVISIONS.



SHOTCRETE REPAIR AREA



GIRDER NUMBER

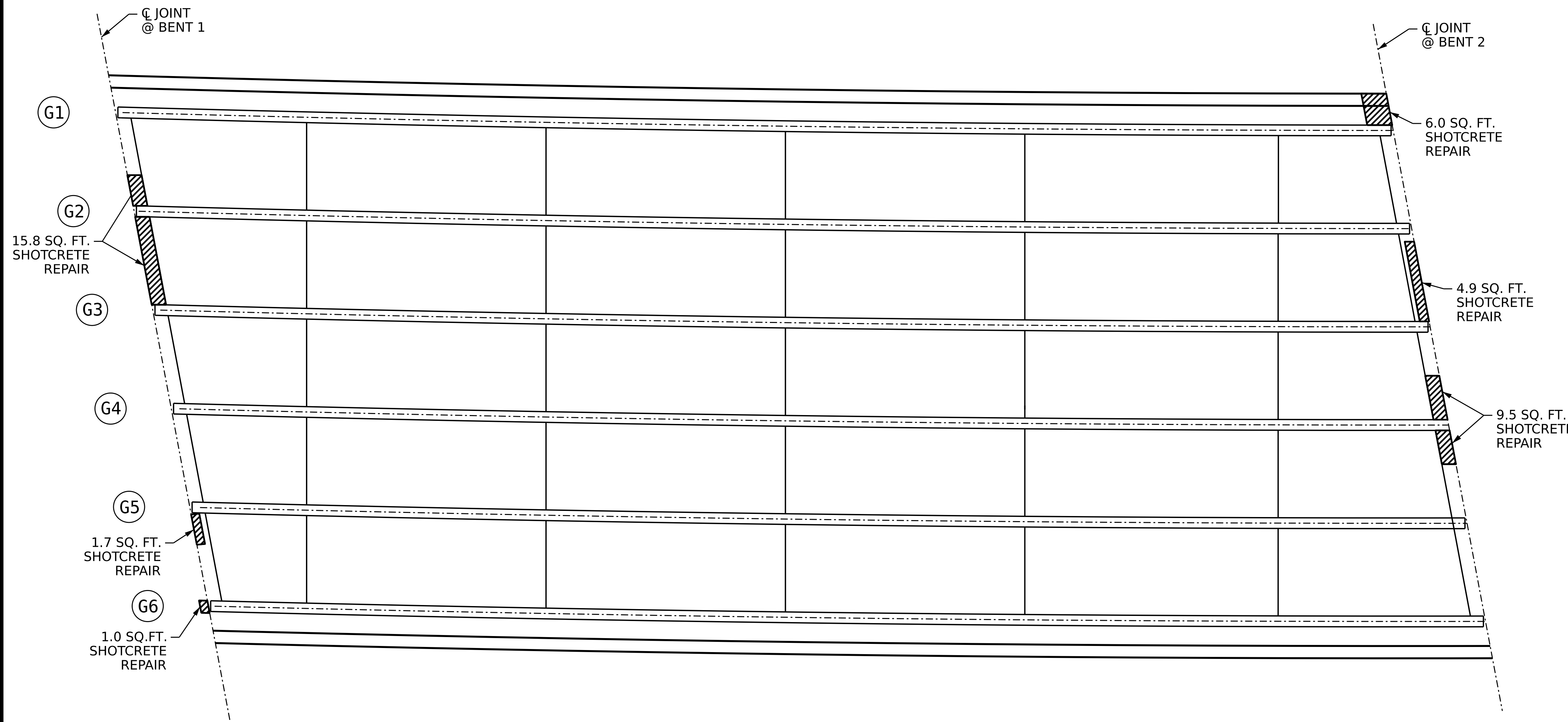

### PLAN

PROJECT NO. **I-5950**

**DAVIDSON** COUNTY

BRIDGE NO. **280146**

SHEET 2 OF 4

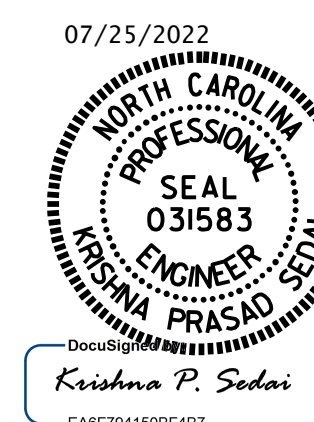

STATE OF NORTH CAROLINA  
DEPARTMENT OF TRANSPORTATION  
RALEIGH

### DECK UNDERSIDE REPAIR SPAN B

REVISIONS						SHEET NO.
NO.	BY:	DATE:	NO.	BY:	DATE:	
1			3			S3-05
2			4			TOTAL SHEETS 15

DOCUMENT NOT CONSIDERED  
FINAL UNLESS ALL  
SIGNATURES COMPLETED

DRAWN BY : E. BAYISSA DATE : 04/2022  
CHECKED BY : A. SORSENGINH DATE : 05/2022

### AS-BUILT REPAIR QUANTITY TABLE

DECK UNDERSIDE REPAIRS SPAN C	QUANTITIES			
	ESTIMATE		ACTUAL	
SHOTCRETE REPAIRS	AREA SF	VOLUME CF	AREA SF	VOLUME CF
UNDERSIDE OF DECK	0	0		
BENT DIAPHRAGM	0	0		
OVERHANG	6.2	2.1		

VALUES IN CHART REPRESENT ESTIMATED REPAIR TOTALS AFTER REMOVAL OF UNSOUND CONCRETE, MIN. OF 1" BEHIND REBAR AND MIN. 2" CLEAR TO SAWCUT. SEE REPAIR DETAILS.

#### NOTES

REPAIR LOCATIONS AND ESTIMATE OF QUANTITIES ARE GIVEN BASED ON THE BEST INFORMATION AVAILABLE. IF ADDITIONAL REPAIRS NOT SHOWN ON THE DRAWINGS ARE DEEMED NECESSARY BY THE ENGINEER, THE ENGINEER SHALL NOTE ON THE DRAWINGS THE APPROXIMATE LOCATION AND DESCRIPTION OF THE REPAIRS AND ENTER THE ACTUAL QUANTITIES INTO THE AS-BUILT REPAIR QUANTITY TABLE.

THE CONTRACTOR SHALL SAW CUT TO A NOMINAL DEPTH OF 1/2" BUT REINFORCING STEEL SHALL NOT BE DAMAGED.

THE CONTRACTOR SHALL REMOVE SURFACE CONCRETE TO VERIFY THAT SAWCUT DEPTH WILL NOT DAMAGE EXISTING REINFORCING STEEL.

SHOTCRETE REPAIRS MAYBE SUBSTITUTED IN LIEU OF CONCRETE REPAIRS WITH THE APPROVAL OF THE ENGINEER.

FOR UNDERSIDE DECK REPAIR, SEE "OVERHANG, DIAPHRAGM AND BRIDGE RAIL REPAIR DETAILS" SHEET.

FOR SHOTCRETE REPAIRS, SEE SPECIAL PROVISIONS.

FOR CONCRETE REPAIRS, SEE SPECIAL PROVISIONS.

PRIOR TO CLEANING AND PAINTING, REPLACE AND /OR TIGHTEN ANCHOR BOLT NUTS, SEE SPECIAL PROVISIONS.

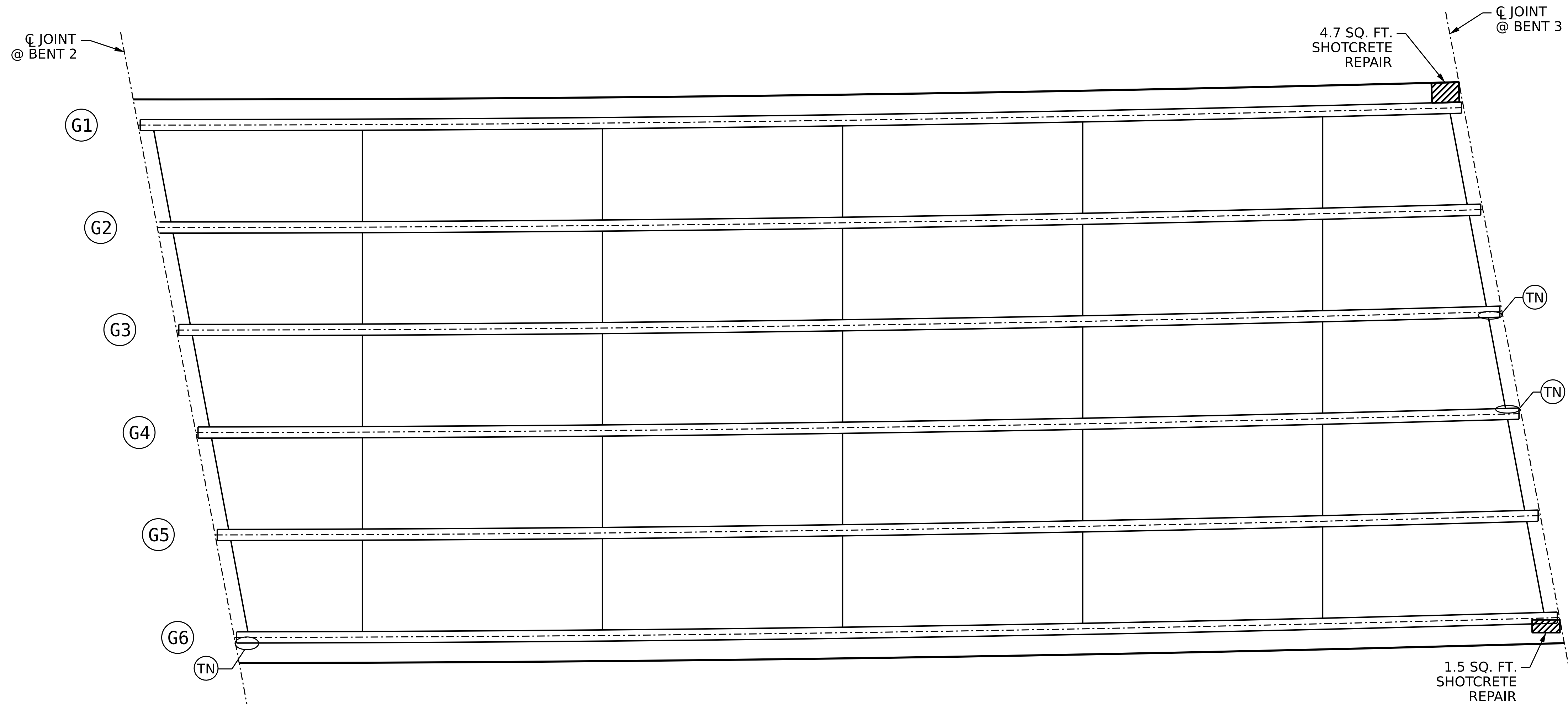

### PLAN

-  SHOTCRETE REPAIR AREA
-  GIRDER NUMBER
-  PLATING REPAIR
-  TIGHTEN ANCHOR BOLT NUT

PROJECT NO. **I-5950**

**DAVIDSON** COUNTY

BRIDGE NO. **280146**

SHEET 3 OF 4

STATE OF NORTH CAROLINA  
DEPARTMENT OF TRANSPORTATION  
RALEIGH

**DECK UNDERSIDE REPAIR  
SPAN C**

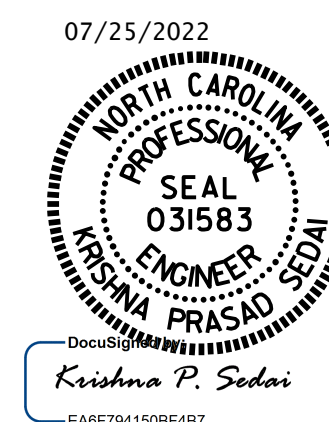

#### REVISIONS

NO.	BY:	DATE:	NO.	BY:	DATE:	SHEET NO.
1			3			TOTAL SHEETS
2			4			15

DOCUMENT NOT CONSIDERED  
FINAL UNLESS ALL  
SIGNATURES COMPLETED

DRAWN BY : E. BAYISSA DATE : 04/2022  
CHECKED BY : A. SORSENGINH DATE : 05/2022

### AS-BUILT REPAIR QUANTITY TABLE

DECK UNDERSIDE REPAIRS SPAN D	QUANTITIES			
	ESTIMATE		ACTUAL	
SHOTCRETE REPAIRS	AREA SF	VOLUME CF	AREA SF	VOLUME CF
UNDERSIDE OF DECK	0	0		
BENT DIAPHRAGM	0	0		
OVERHANG	1.3	0.4		

VALUES IN CHART REPRESENT ESTIMATED REPAIR TOTALS AFTER REMOVAL OF UNSOUND CONCRETE, MIN. OF 1" BEHIND REBAR AND MIN. 2" CLEAR TO SAWCUT. SEE REPAIR DETAILS.

#### NOTES

REPAIR LOCATIONS AND ESTIMATE OF QUANTITIES ARE GIVEN BASED ON THE BEST INFORMATION AVAILABLE. IF ADDITIONAL REPAIRS NOT SHOWN ON THE DRAWINGS ARE DEEMED NECESSARY BY THE ENGINEER, THE ENGINEER SHALL NOTE ON THE DRAWINGS THE APPROXIMATE LOCATION AND DESCRIPTION OF THE REPAIRS AND ENTER THE ACTUAL QUANTITIES INTO THE AS-BUILT REPAIR QUANTITY TABLE.

THE CONTRACTOR SHALL SAW CUT TO A NOMINAL DEPTH OF 1/2" BUT REINFORCING STEEL SHALL NOT BE DAMAGED.

CONTRACTOR SHALL REMOVE SURFACE CONCRETE TO VERIFY THAT SAWCUT DEPTH WILL NOT DAMAGE EXISTING REINFORCING STEEL.

SHOTCRETE REPAIRS MAYBE SUBSTITUTED IN LIEU OF CONCRETE REPAIRS WITH THE APPROVAL OF THE ENGINEER.

FOR UNDERSIDE DECK REPAIR, SEE "OVERHANG, DIAPHRAGM AND BRIDGE RAIL REPAIR DETAILS" SHEET.

FOR SHOTCRETE REPAIRS, SEE SPECIAL PROVISIONS.

FOR CONCRETE REPAIRS, SEE SPECIAL PROVISIONS.

PRIOR TO CLEANING AND PAINTING, REPLACE AND /OR TIGHTEN ANCHOR BOLT NUTS. SEE SPECIAL PROVISIONS.

-  SHOTCRETE REPAIR AREA
-  GIRDER NUMBER
-  PLATING REPAIR
-  TIGHTEN ANCHOR BOLT NUT

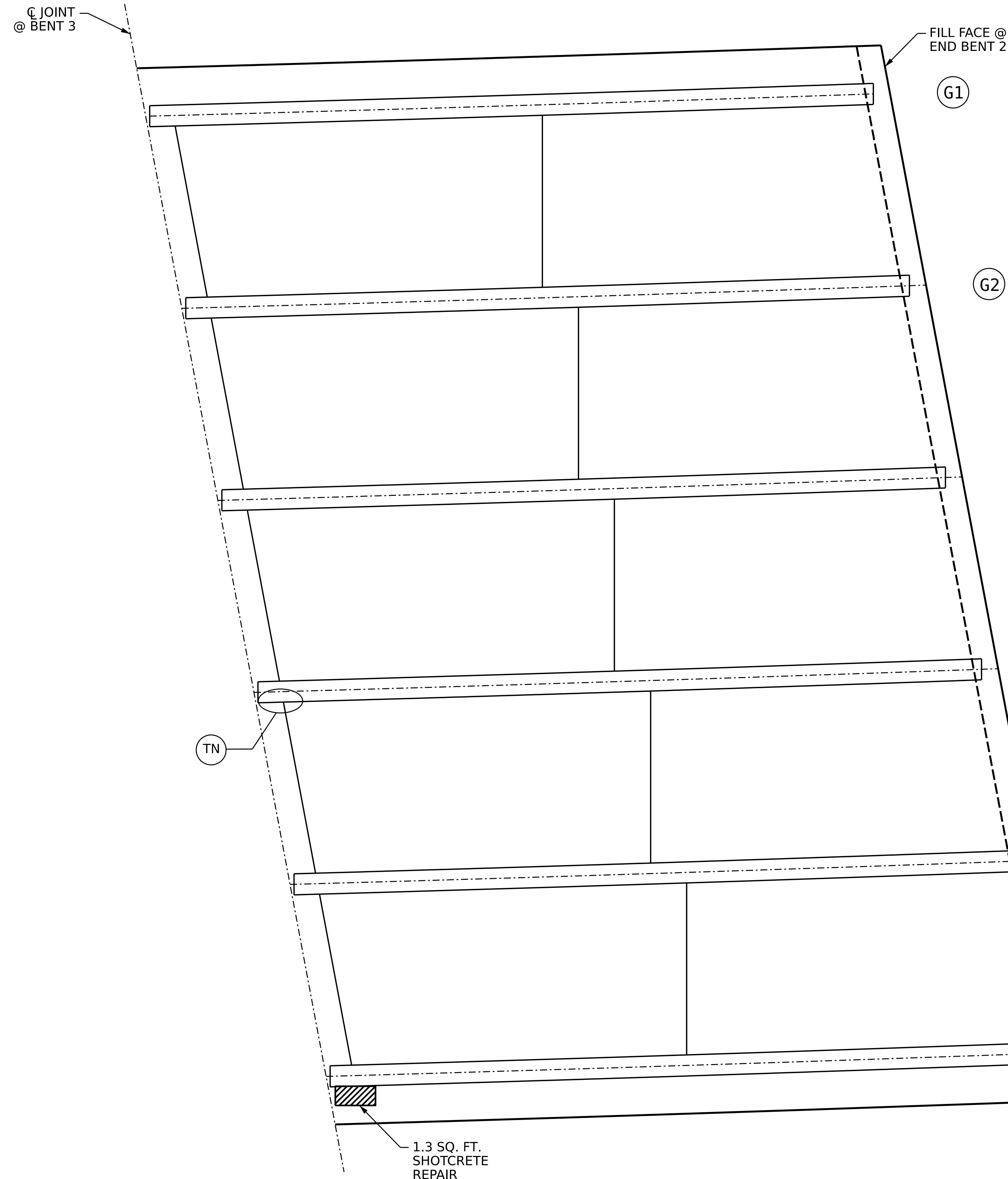

PROJECT NO. I-5950  
DAVIDSON COUNTY  
 BRIDGE NO. 280146

SHEET 4 OF 4

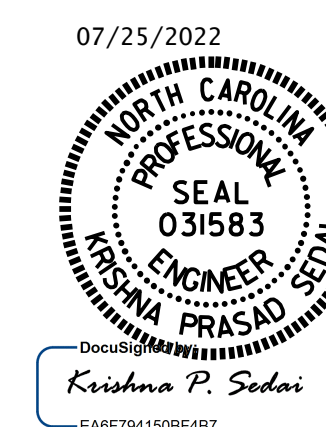

STATE OF NORTH CAROLINA  
 DEPARTMENT OF TRANSPORTATION  
 RALEIGH

### DECK UNDERSIDE REPAIR SPAN D

REVISIONS						SHEET NO.
NO.	BY:	DATE:	NO.	BY:	DATE:	53-07
1			3			TOTAL SHEETS
2			4			15

DOCUMENT NOT CONSIDERED  
 FINAL UNLESS ALL  
 SIGNATURES COMPLETED

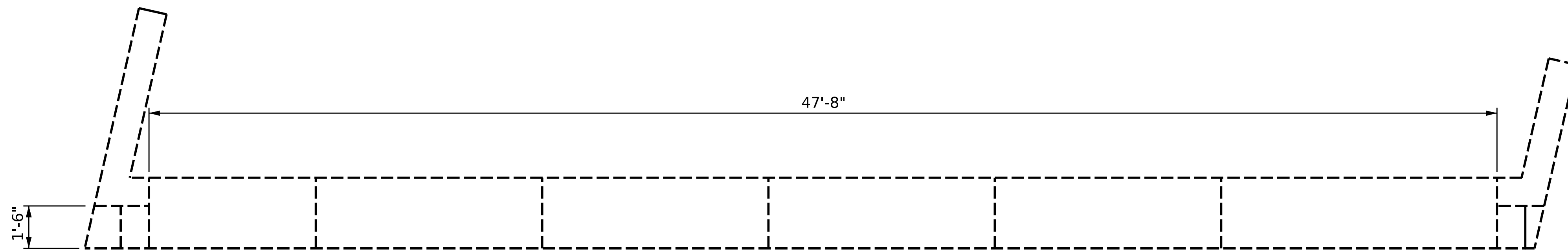

DRAWN BY : E. BAYISSA DATE : 04/2022  
 CHECKED BY : A. SORSENGINH DATE : 05/2022

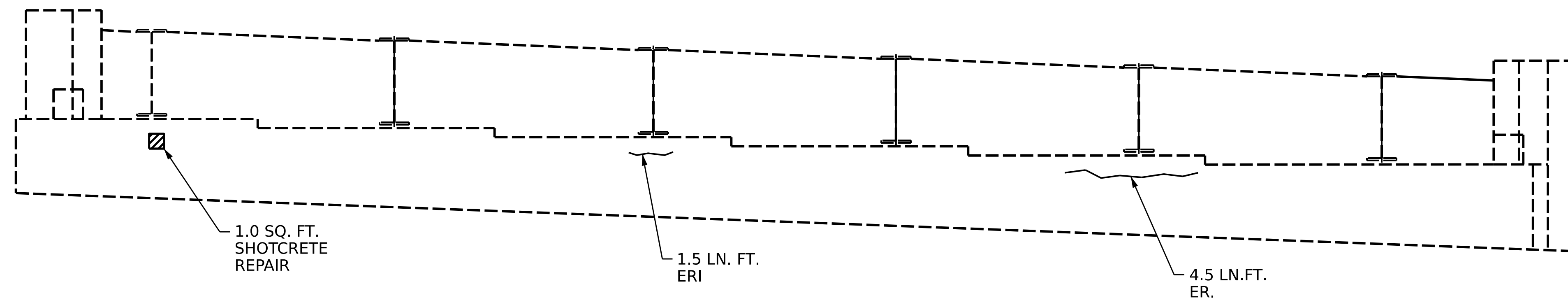

**PLAN**



**ELEVATION**

-  SHOTCRETE REPAIR AREA
-  CONCRETE REPAIR AREA
-  EPOXY RESIN INJECTION

AS-BUILT REPAIR QUANTITY TABLE				
REPAIRS - END BENT 1	QUANTITIES			
	ESTIMATE		ACTUAL	
SHOTCRETE REPAIRS	AREA SF	VOLUME CF	AREA SF	VOLUME CF
CAP	1.0	0.5		
CURTAIN WALL	0	0		
WINGWALL				
CONCRETE REPAIRS	AREA SF	VOLUME CF	AREA SF	VOLUME CF
CAP	0	0		
CURTAIN WALL	0	0		
WINGWALL	0	0		
EPOXY RESIN INJECTION		LINEAR FT		LINEAR FT
CAP		6		
CURTAIN WALL		0		
WINGWALL				
EPOXY COATING		AREA SF		AREA SF
CAP		71.5		

VALUES IN CHART REPRESENT ESTIMATED REPAIR TOTALS AFTER REMOVAL OF UNSOUND CONCRETE, MIN. OF 1" BEHIND REBAR AND MIN. 2" CLEAR TO SAWCUT. SEE "TYPICAL CAP AND COLUMN REPAIR DETAILS" SHEET.

**NOTES**

REPAIR LOCATIONS AND ESTIMATE OF QUANTITIES ARE GIVEN BASED ON THE BEST INFORMATION AVAILABLE. IF ADDITIONAL REPAIRS NOT SHOWN ON THE DRAWINGS ARE DEEMED NECESSARY BY THE ENGINEER, THE ENGINEER SHALL NOTE ON THE DRAWINGS THE APPROXIMATE LOCATION AND DESCRIPTION OF THE REPAIRS AND ENTER THE ACTUAL QUANTITIES INTO THE AS-BUILT REPAIR QUANTITY TABLE.

CLEAN AND REMOVE DEBRIS FROM THE TOP OF THE CAP AND APPLY EPOXY PROTECTIVE COATING. EPOXY COATING SHALL BE APPLIED TO THE TOP SURFACE OF THE CAP. THE CONTRACTOR SHALL NOT COAT THE AREA OF THE CAP BENEATH THE MASONRY PLATES. FOR EPOXY COATING, SEE SPECIAL PROVISIONS.

SHOTCRETE REPAIRS MAYBE SUBSTITUTED IN LIEU OF CONCRETE REPAIRS WITH THE APPROVAL OF THE ENGINEER.

FOR CAP AND COLUMN REPAIR DETAILS, SEE "TYPICAL CAP AND COLUMN REPAIR DETAILS" SHEET.

FOR SHOTCRETE REPAIRS, SEE SPECIAL PROVISIONS.

FOR CONCRETE REPAIRS, SEE SPECIAL PROVISIONS.

FOR EPOXY RESIN INJECTION, SEE SPECIAL PROVISIONS.

PROJECT NO. **I-5950**  
**DAVIDSON** COUNTY  
 BRIDGE NO. **280146**

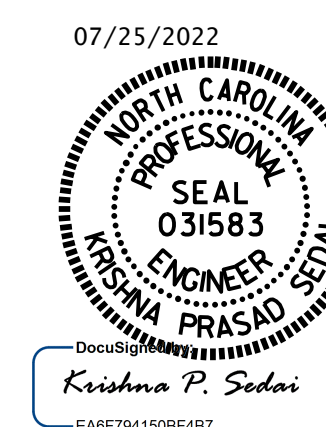

STATE OF NORTH CAROLINA  
 DEPARTMENT OF TRANSPORTATION  
 RALEIGH  
**SUBSTRUCTURE REPAIR  
 END BENT 1**



DOCUMENT NOT CONSIDERED  
 FINAL UNLESS ALL  
 SIGNATURES COMPLETED

REVISIONS						SHEET NO.
NO.	BY:	DATE:	NO.	BY:	DATE:	S3-08
1			3			TOTAL SHEETS
2			4			15

DRAWN BY : E. BAYISSA DATE : 04/2022  
 CHECKED BY : A. SORSENGINH DATE : 05/2022

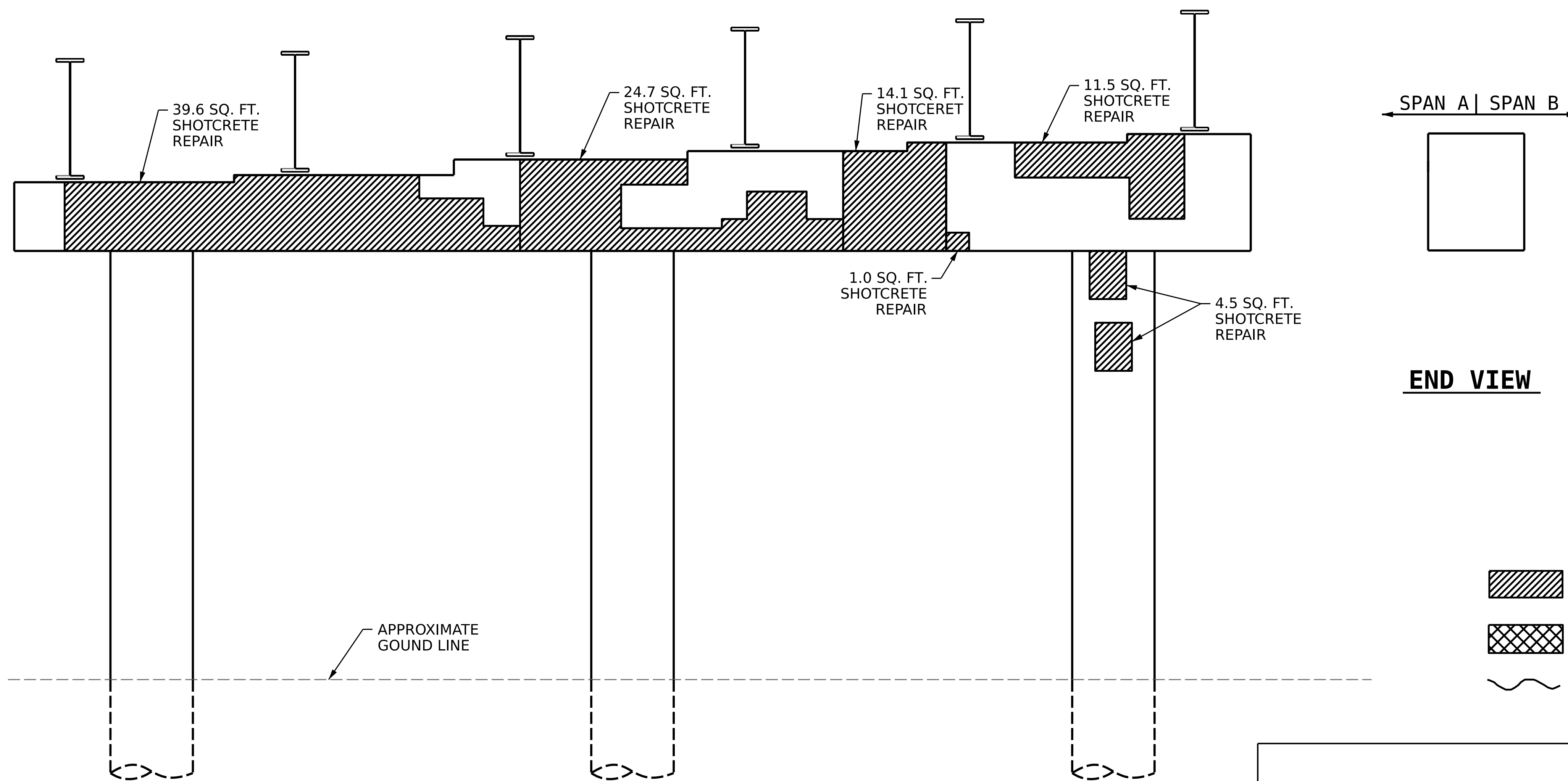
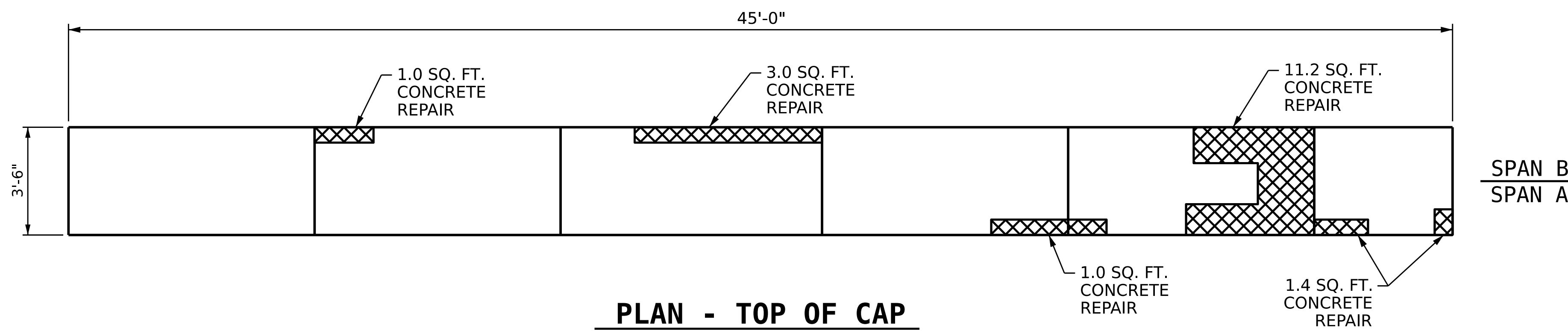

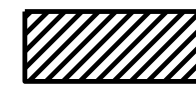

-  SHOTCRETE REPAIR AREA
-  CONCRETE REPAIR AREA
-  EPOXY RESIN INJECTION

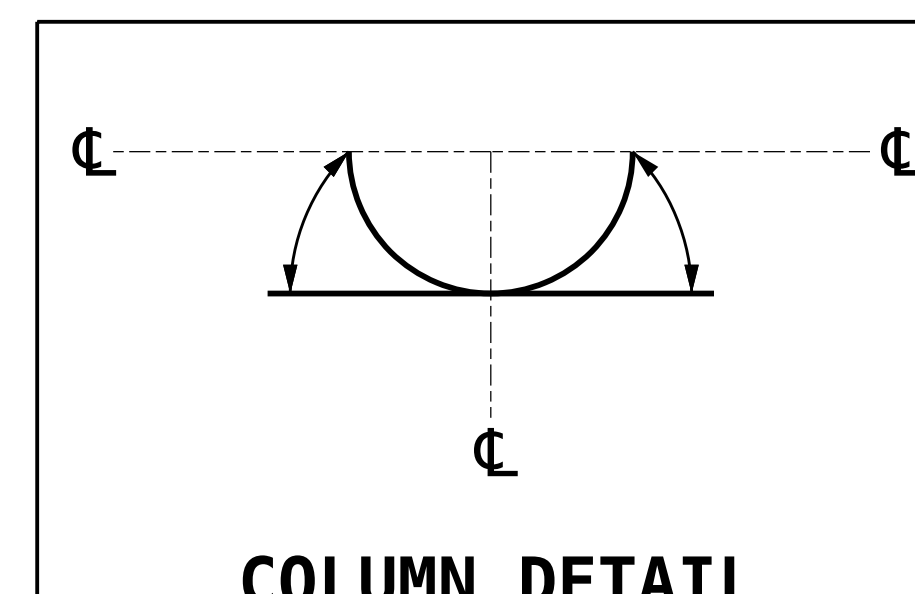

AS-BUILT REPAIR QUANTITY TABLE				
BENT 1 SPAN A FACE	QUANTITIES			
	ESTIMATE		ACTUAL	
SHOTCRETE REPAIRS	AREA SF	VOLUME CF	AREA SF	VOLUME CF
CAP	90.9	45.5		
COLUMN	4.5	2.3		
CONCRETE REPAIRS	AREA SF	VOLUME CF	AREA SF	VOLUME CF
CAP	17.6	8.8		
EPOXY RESIN INJECTION		LINEAR FT		LINEAR FT
CAP		0.0		
COLUMN		0		
EPOXY COATING		AREA SF		AREA SF
CAP		141.0		

VALUES IN CHART REPRESENT ESTIMATED REPAIR TOTALS AFTER REMOVAL OF UNSOUND CONCRETE, MIN. OF 1" BEHIND REBAR AND MIN. 2" CLEAR TO SAWCUT. SEE "TYPICAL CAP AND COLUMN REPAIR DETAILS" SHEET.

**NOTES**

REPAIR LOCATIONS AND ESTIMATE OF QUANTITIES ARE GIVEN BASED ON THE BEST INFORMATION AVAILABLE. IF ADDITIONAL REPAIRS NOT SHOWN ON THE DRAWINGS ARE DEEMED NECESSARY BY THE ENGINEER, THE ENGINEER SHALL NOTE ON THE DRAWINGS THE APPROXIMATE LOCATION AND DESCRIPTION OF THE REPAIRS AND ENTER THE ACTUAL QUANTITIES INTO THE AS-BUILT REPAIR QUANTITY TABLE.

CLEAN AND REMOVE DEBRIS FROM THE TOP OF THE CAP AND APPLY EPOXY PROTECTIVE COATING. EPOXY COATING SHALL BE APPLIED TO THE TOP SURFACE OF THE CAP. THE CONTRACTOR SHALL NOT COAT THE AREA OF THE CAP BENEATH THE MASONRY PLATES. FOR EPOXY COATING, SEE SPECIAL PROVISIONS.

SHOTCRETE REPAIRS MAYBE SUBSTITUTED IN LIEU OF CONCRETE REPAIRS WITH THE APPROVAL OF THE ENGINEER.

FOR CAP AND COLUMN REPAIR DETAILS, SEE "TYPICAL CAP AND COLUMN REPAIR DETAILS" SHEET.

FOR SHOTCRETE REPAIRS, SEE SPECIAL PROVISIONS.

FOR CONCRETE REPAIRS, SEE SPECIAL PROVISIONS.

FOR EPOXY RESIN INJECTION, SEE SPECIAL PROVISIONS.

PROJECT NO. **I-5950**  
**DAVIDSON** COUNTY  
 BRIDGE NO. **280146**

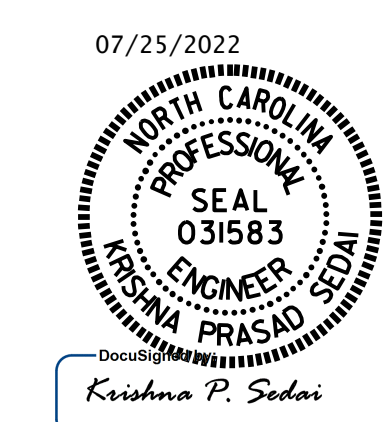

STATE OF NORTH CAROLINA  
 DEPARTMENT OF TRANSPORTATION  
 RALEIGH

**SUBSTRUCTURE REPAIR  
 BENT 1  
 SPAN A FACE**

DRAWN BY : E. BAYISSA DATE : 04/2022  
 CHECKED BY : A. SORSENGINH DATE : 04/2022

DOCUMENT NOT CONSIDERED  
 FINAL UNLESS ALL  
 SIGNATURES COMPLETED

REVISIONS					SHEET NO.
NO.	BY:	DATE:	NO.	BY:	DATE:
1			3		
2			4		

TOTAL SHEETS: 15

### AS-BUILT REPAIR QUANTITY TABLE

BENT 1 SPAN B FACE	QUANTITIES			
	ESTIMATE		ACTUAL	
SHOTCRETE REPAIRS	AREA SF	VOLUME CF	AREA SF	VOLUME CF
CAP	104.3	52.2		
COLUMN	33.2	16.6		
CONCRETE REPAIRS	AREA SF	VOLUME CF	AREA SF	VOLUME CF
CAP	0	0		
COLUMN	0	0		
EPOXY RESIN INJECTION	LINEAR FT		LINEAR FT	
CAP	0			
COLUMN	0			

VALUES IN CHART REPRESENT ESTIMATED REPAIR TOTALS AFTER REMOVAL OF UNSOUND CONCRETE, MIN. OF 1" BEHIND REBAR AND MIN. 2" CLEAR TO SAWCUT. SEE "TYPICAL CAP AND COLUMN REPAIR DETAILS" SHEET.

#### NOTES

REPAIR LOCATIONS AND ESTIMATE OF QUANTITIES ARE GIVEN BASED ON THE BEST INFORMATION AVAILABLE. IF ADDITIONAL REPAIRS NOT SHOWN ON THE DRAWINGS ARE DEEMED NECESSARY BY THE ENGINEER, THE ENGINEER SHALL NOTE ON THE DRAWINGS THE APPROXIMATE LOCATION AND DESCRIPTION OF THE REPAIRS AND ENTER THE ACTUAL QUANTITIES INTO THE AS-BUILT REPAIR QUANTITY TABLE.



SHOTCRETE REPAIRS MAYBE SUBSTITUTED IN LIEU OF CONCRETE REPAIRS WITH THE APPROVAL OF THE ENGINEER.

FOR CAP AND COLUMN REPAIR DETAILS, SEE "TYPICAL CAP AND COLUMN REPAIR DETAILS" SHEET.

FOR SHOTCRETE REPAIRS, SEE SPECIAL PROVISIONS.

FOR CONCRETE REPAIRS, SEE SPECIAL PROVISIONS.

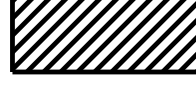
FOR EPOXY RESIN INJECTION, SEE SPECIAL PROVISIONS.

-  SHOTCRETE REPAIR AREA
-  CONCRETE REPAIR AREA
-  EPOXY RESIN INJECTION

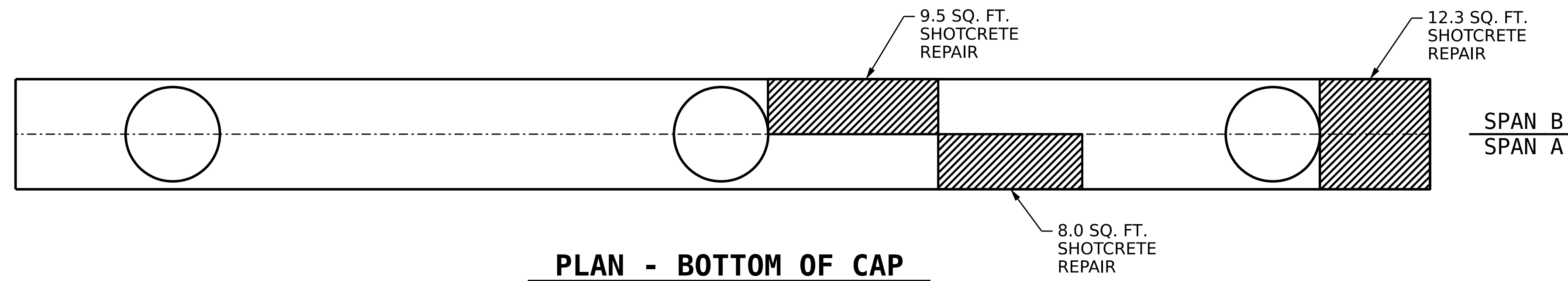

**PLAN - BOTTOM OF CAP**

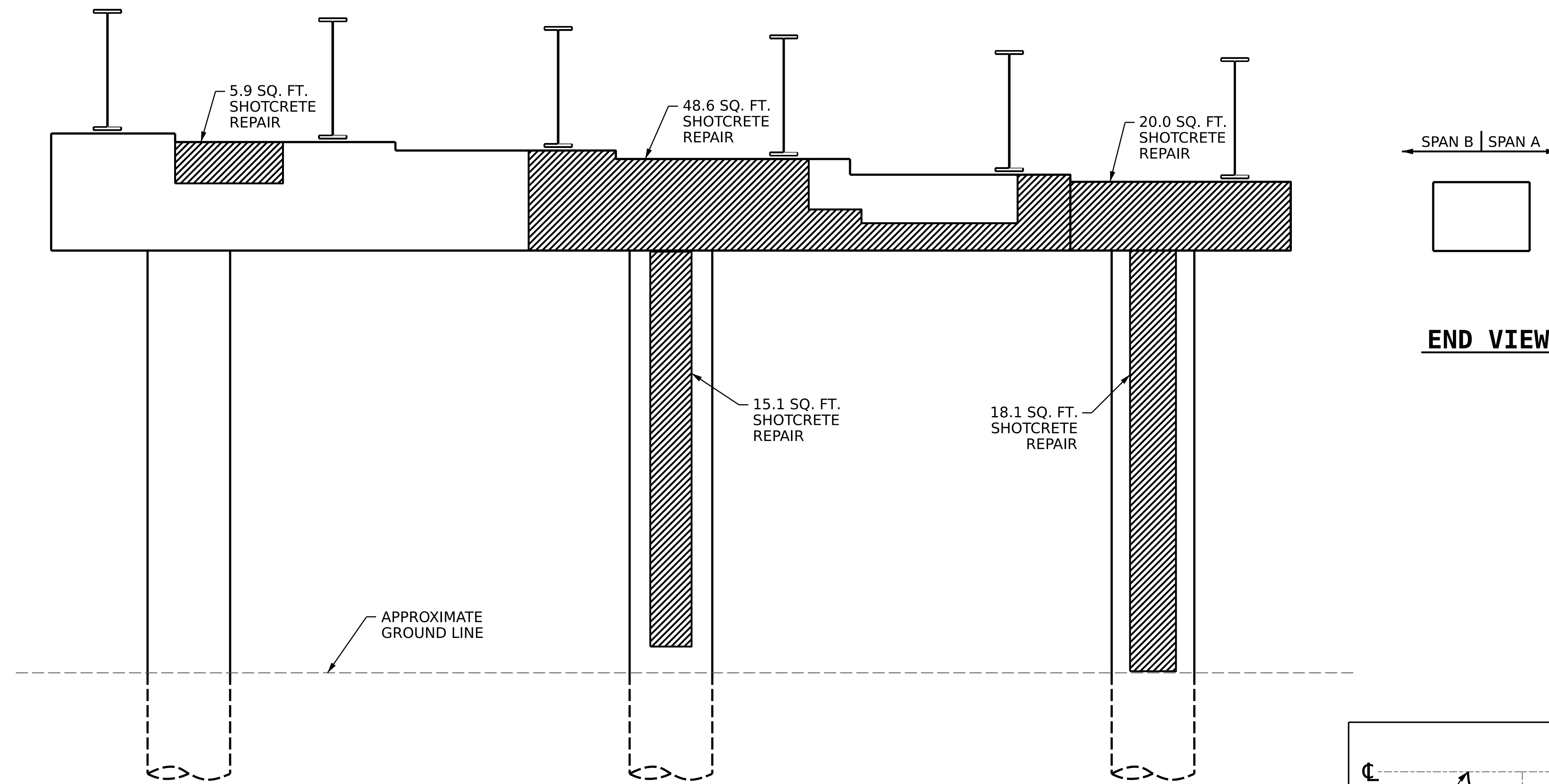

**ELEVATION**

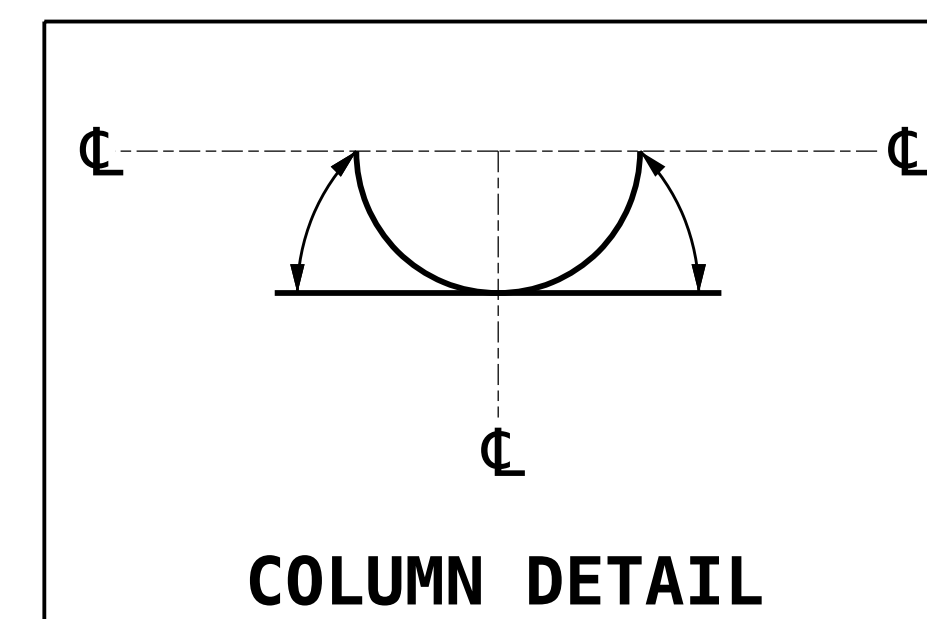

**COLUMN DETAIL**

PROJECT NO. **I-5950**  
**DAVIDSON** COUNTY  
 BRIDGE NO. **280146**

SHEET 2 OF 2

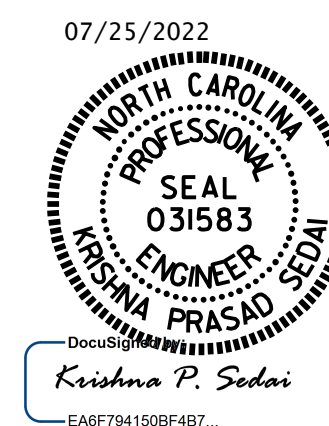

STATE OF NORTH CAROLINA  
 DEPARTMENT OF TRANSPORTATION  
 RALEIGH  
**SUBSTRUCTURE REPAIR  
 BENT 1  
 SPAN B FACE**

REVISIONS						SHEET NO. S3-10
NO.	BY:	DATE:	NO.	BY:	DATE:	
1			3			TOTAL SHEETS 15
2			4			

DOCUMENT NOT CONSIDERED  
 FINAL UNLESS ALL  
 SIGNATURES COMPLETED

DRAWN BY : E. BAYISSA DATE : 04/2022  
 CHECKED BY : A. SORSENGINH DATE : 04/2022

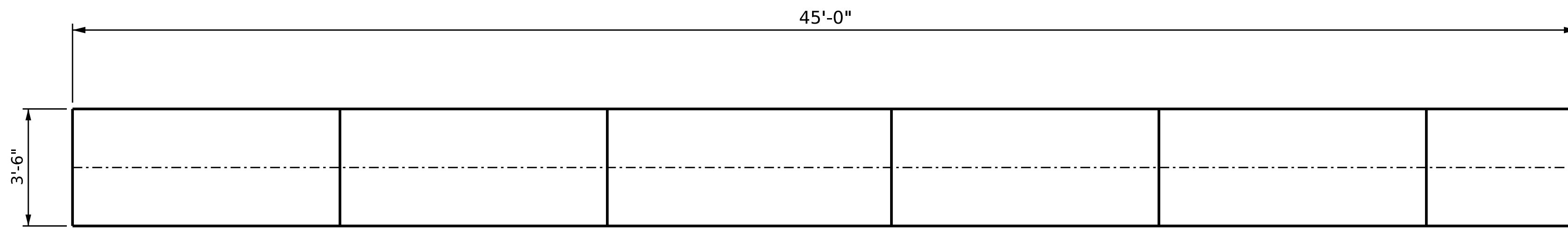

**PLAN - TOP OF CAP**

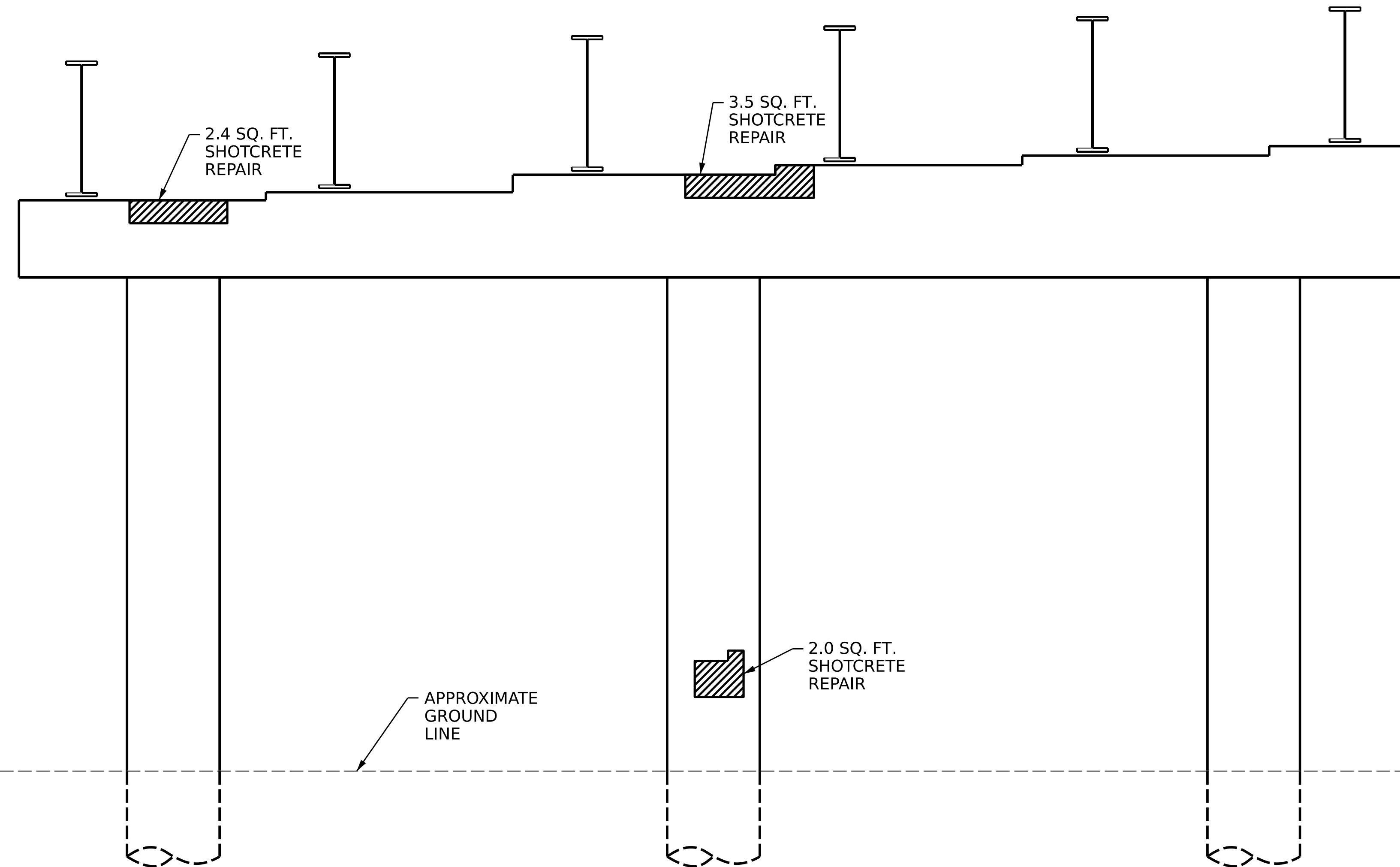

**ELEVATION**

SPAN B | SPAN C

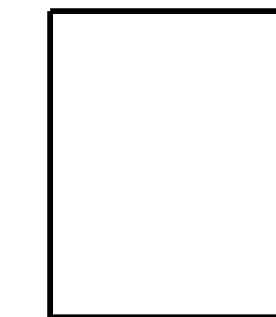

**END VIEW**

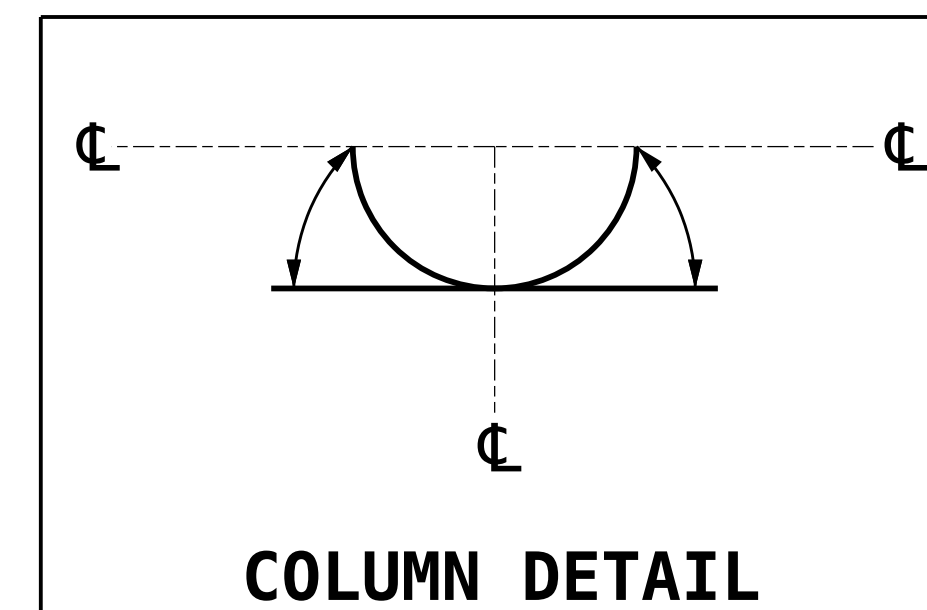

AS-BUILT REPAIR QUANTITY TABLE				
BENT 2 SPAN B FACE	QUANTITIES			
	ESTIMATE		ACTUAL	
SHOTCRETE REPAIRS	AREA SF	VOLUME CF	AREA SF	VOLUME CF
CAP	5.9	3.0		
COLUMN	2.0	1.0		
CONCRETE REPAIRS	AREA SF	VOLUME CF	AREA SF	VOLUME CF
CAP	0.0	0.0		
EPOXY RESIN INJECTION	LINEAR FT		LINEAR FT	
CAP	0		0	
COLUMN	0		0	
EPOXY COATING	AREA SF		AREA SF	
CAP	141.0		0	

VALUES IN CHART REPRESENT ESTIMATED REPAIR TOTALS AFTER REMOVAL OF UNSOUND CONCRETE, MIN. OF 1" BEHIND REBAR AND MIN. 2" CLEAR TO SAWCUT. SEE "TYPICAL CAP AND COLUMN REPAIR DETAILS" SHEET.

**NOTES**

REPAIR LOCATIONS AND ESTIMATE OF QUANTITIES ARE GIVEN BASED ON THE BEST INFORMATION AVAILABLE. IF ADDITIONAL REPAIRS NOT SHOWN ON THE DRAWINGS ARE DEEMED NECESSARY BY THE ENGINEER, THE ENGINEER SHALL NOTE ON THE DRAWINGS THE APPROXIMATE LOCATION AND DESCRIPTION OF THE REPAIRS AND ENTER THE ACTUAL QUANTITIES INTO THE AS-BUILT REPAIR QUANTITY TABLE.

CLEAN AND REMOVE DEBRIS FROM THE TOP OF THE CAP AND APPLY EPOXY PROTECTIVE COATING. EPOXY COATING SHALL BE APPLIED TO THE TOP SURFACE OF THE CAP. THE CONTRACTOR SHALL NOT COAT THE AREA OF THE CAP BENEATH THE MASONRY PLATES. FOR EPOXY COATING, SEE SPECIAL PROVISIONS.

SHOTCRETE REPAIRS MAYBE SUBSTITUTED IN LIEU OF CONCRETE REPAIRS WITH THE APPROVAL OF THE ENGINEER.

FOR CAP AND COLUMN REPAIR DETAILS, SEE "TYPICAL CAP AND COLUMN REPAIR DETAILS" SHEET.

FOR SHOTCRETE REPAIRS, SEE SPECIAL PROVISIONS.

FOR CONCRETE REPAIRS, SEE SPECIAL PROVISIONS.

FOR EPOXY RESIN INJECTION, SEE SPECIAL PROVISIONS.

PROJECT NO. **I-5950**  
**DAVIDSON** COUNTY  
 BRIDGE NO. **280146**

SHEET 1 OF 2

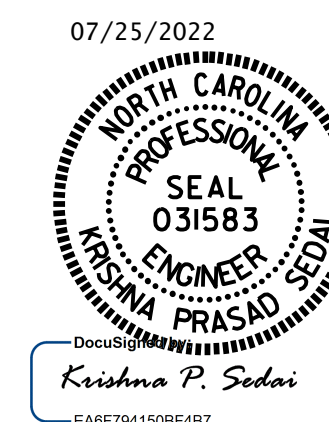

STATE OF NORTH CAROLINA  
 DEPARTMENT OF TRANSPORTATION  
 RALEIGH  
**SUBSTRUCTURE REPAIR**  
**BENT 2**  
**SPAN B FACE**

REVISIONS						SHEET NO.
NO.	BY:	DATE:	NO.	BY:	DATE:	S3-11
1			3			TOTAL SHEETS
2			4			15

DOCUMENT NOT CONSIDERED FINAL UNLESS ALL SIGNATURES COMPLETED

DRAWN BY : E. BAYISSA DATE : 04/2022  
 CHECKED BY : A. SORSENGINH DATE : 04/2022

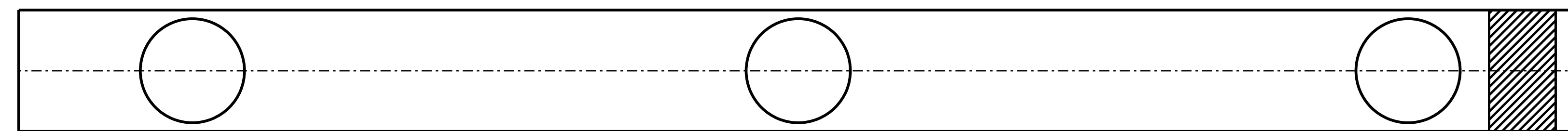

**PLAN - BOTTOM OF CAP**

6.7 SQ. FT. SHOTCRETE REPAIR

SPAN C  
SPAN B

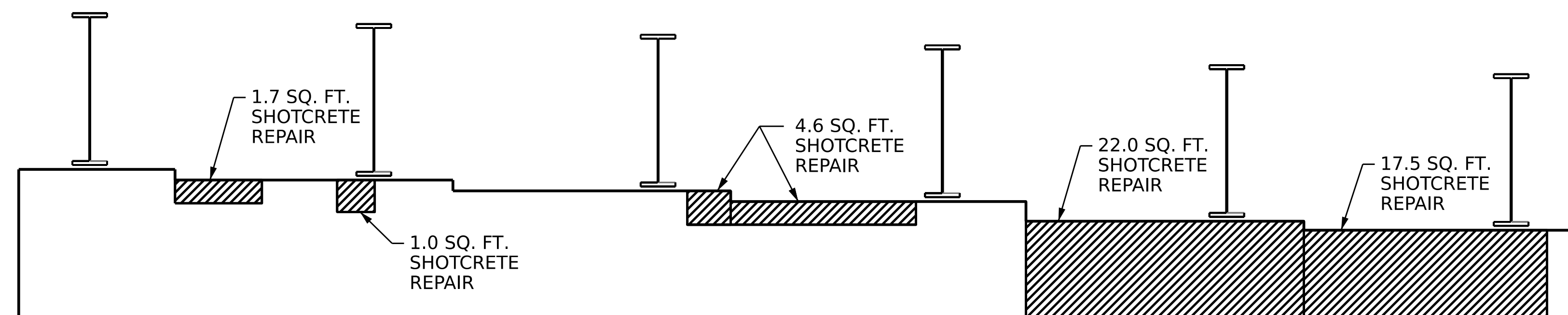

SPAN C | SPAN B

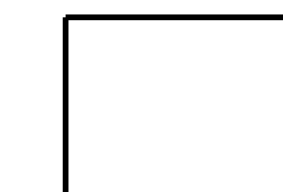

**END VIEW**

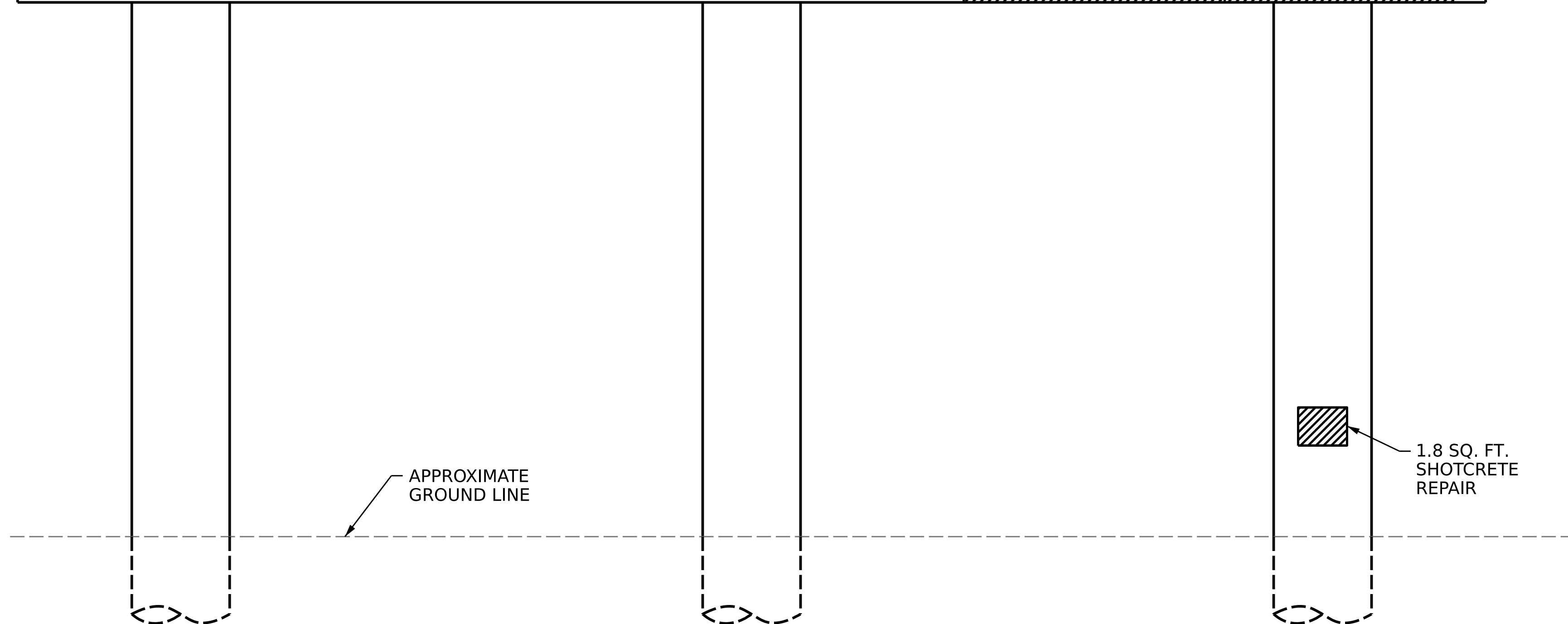

APPROXIMATE GROUND LINE

1.8 SQ. FT. SHOTCRETE REPAIR

**ELEVATION**

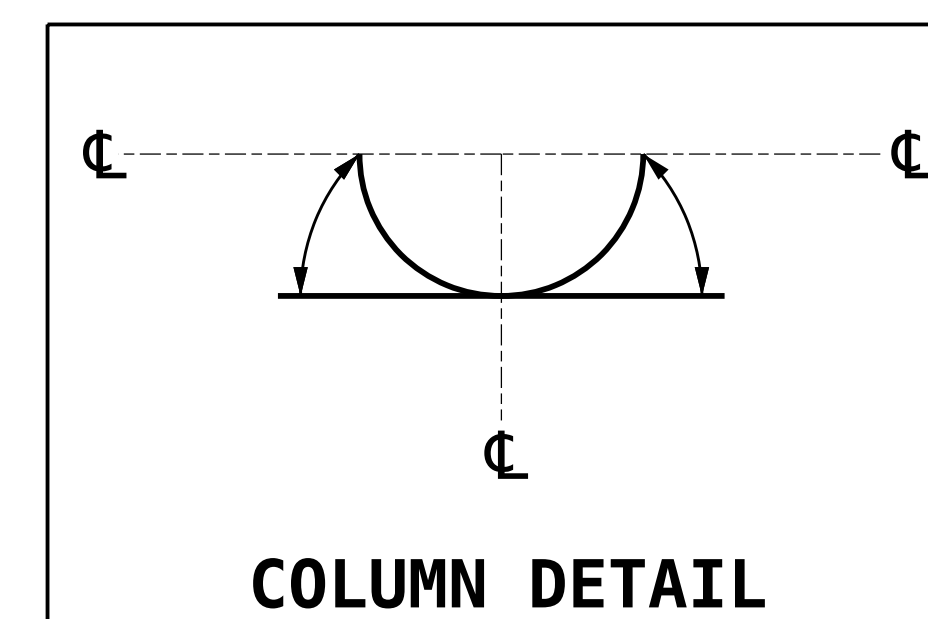

**COLUMN DETAIL**

AS-BUILT REPAIR QUANTITY TABLE				
BENT 2 SPAN C FACE	QUANTITIES			
	ESTIMATE		ACTUAL	
SHOTCRETE REPAIRS	AREA SF	VOLUME CF	AREA SF	VOLUME CF
CAP	53.5	26.8		
COLUMN	1.8	0.9		
CONCRETE REPAIRS	AREA SF	VOLUME CF	AREA SF	VOLUME CF
CAP	0	0		
COLUMN	0	0		
EPOXY RESIN INJECTION		LINEAR FT		LINEAR FT
CAP		0		
COLUMN		0		

VALUES IN CHART REPRESENT ESTIMATED REPAIR TOTALS AFTER REMOVAL OF UNSOUND CONCRETE, MIN. OF 1" BEHIND REBAR AND MIN. 2" CLEAR TO SAWCUT. SEE "TYPICAL CAP AND COLUMN REPAIR DETAILS" SHEET.

**NOTES**

REPAIR LOCATIONS AND ESTIMATE OF QUANTITIES ARE GIVEN BASED ON THE BEST INFORMATION AVAILABLE. IF ADDITIONAL REPAIRS NOT SHOWN ON THE DRAWINGS ARE DEEMED NECESSARY BY THE ENGINEER, THE ENGINEER SHALL NOTE ON THE DRAWINGS THE APPROXIMATE LOCATION AND DESCRIPTION OF THE REPAIRS AND ENTER THE ACTUAL QUANTITIES INTO THE AS-BUILT REPAIR QUANTITY TABLE.



SHOTCRETE REPAIRS MAYBE SUBSTITUTED IN LIEU OF CONCRETE REPAIRS WITH THE APPROVAL OF THE ENGINEER.

FOR CAP AND COLUMN REPAIR DETAILS, SEE "TYPICAL CAP AND COLUMN REPAIR DETAILS" SHEET.

FOR SHOTCRETE REPAIRS, SEE SPECIAL PROVISIONS.

FOR CONCRETE REPAIRS, SEE SPECIAL PROVISIONS.

FOR EPOXY RESIN INJECTION, SEE SPECIAL PROVISIONS.

-  SHOTCRETE REPAIR AREA
-  CONCRETE REPAIR AREA
-  EPOXY RESIN INJECTION

PROJECT NO. **I-5950**  
**DAVIDSON** COUNTY  
 BRIDGE NO. **280146**

SHEET 2 OF 2

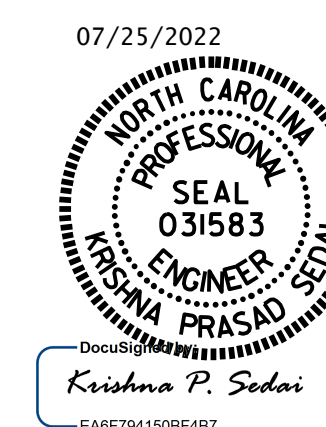

STATE OF NORTH CAROLINA  
 DEPARTMENT OF TRANSPORTATION  
 RALEIGH

**SUBSTRUCTURE REPAIR  
 BENT 2  
 SPAN C FACE**

REVISIONS						SHEET NO.
NO.	BY:	DATE:	NO.	BY:	DATE:	S3-12
1			3			TOTAL SHEETS
2			4			15

DOCUMENT NOT CONSIDERED FINAL UNLESS ALL SIGNATURES COMPLETED

DRAWN BY : E. BAYISSA DATE : 04/2022  
 CHECKED BY : A. SORSENGINH DATE : 04/2022

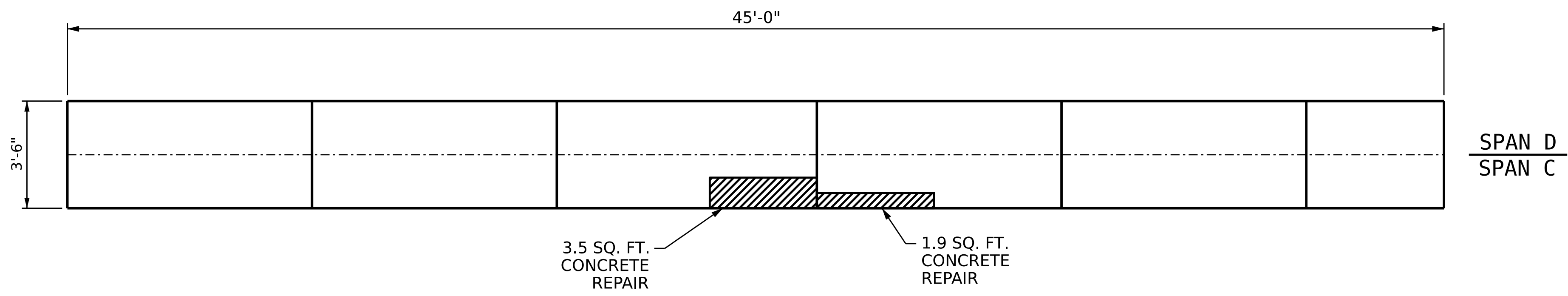

**PLAN - TOP OF CAP**

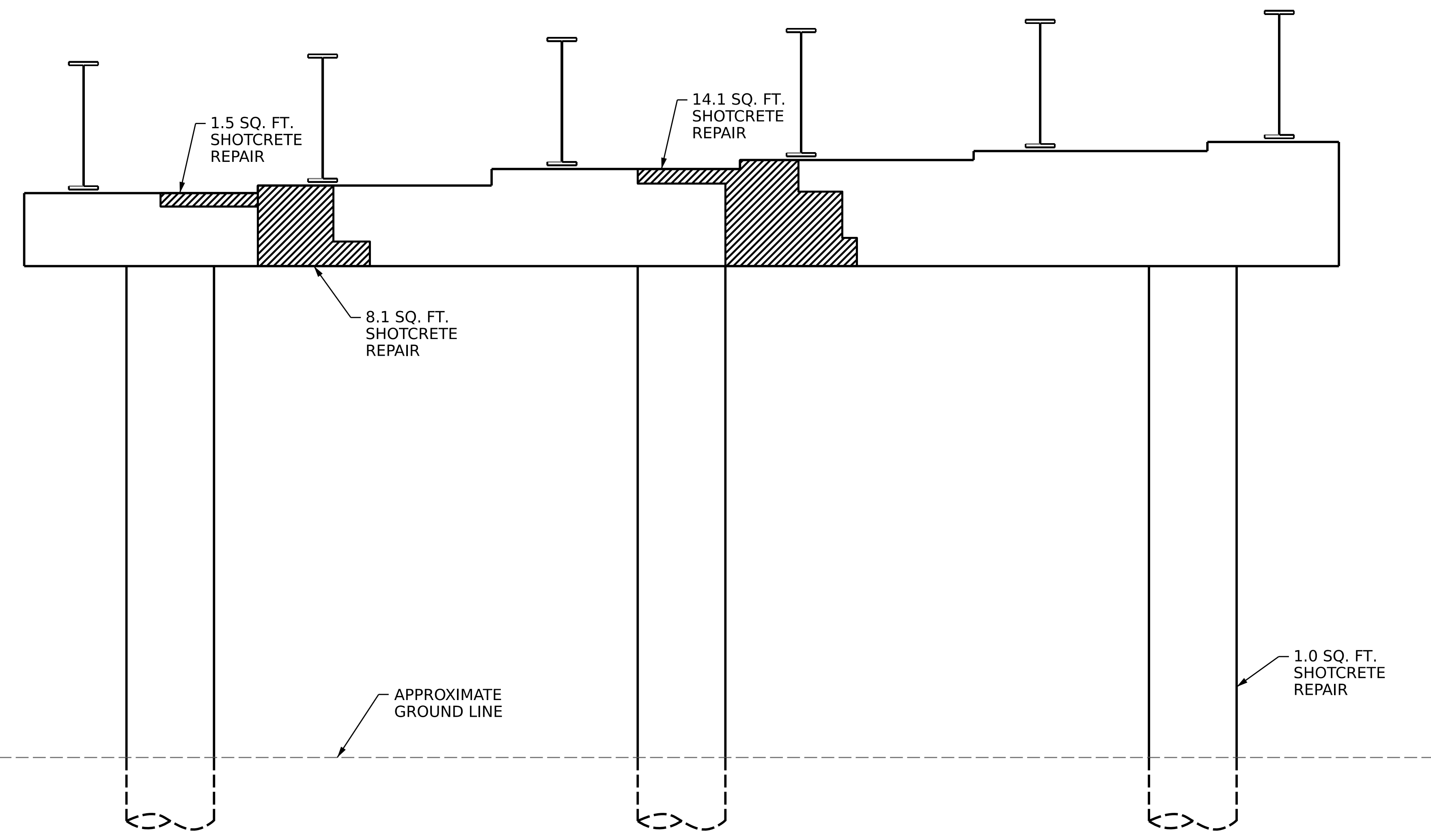

**ELEVATION**

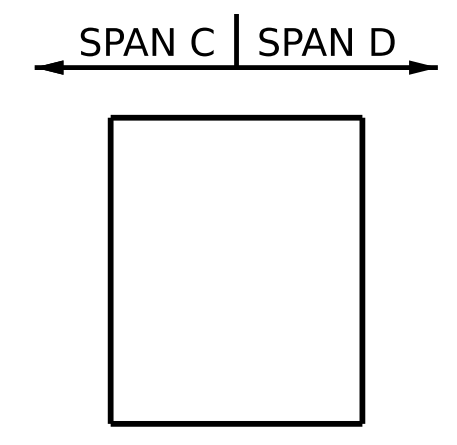

**END VIEW**

- SHOTCRETE REPAIR AREA
- CONCRETE REPAIR AREA
- EPOXY RESIN INJECTION

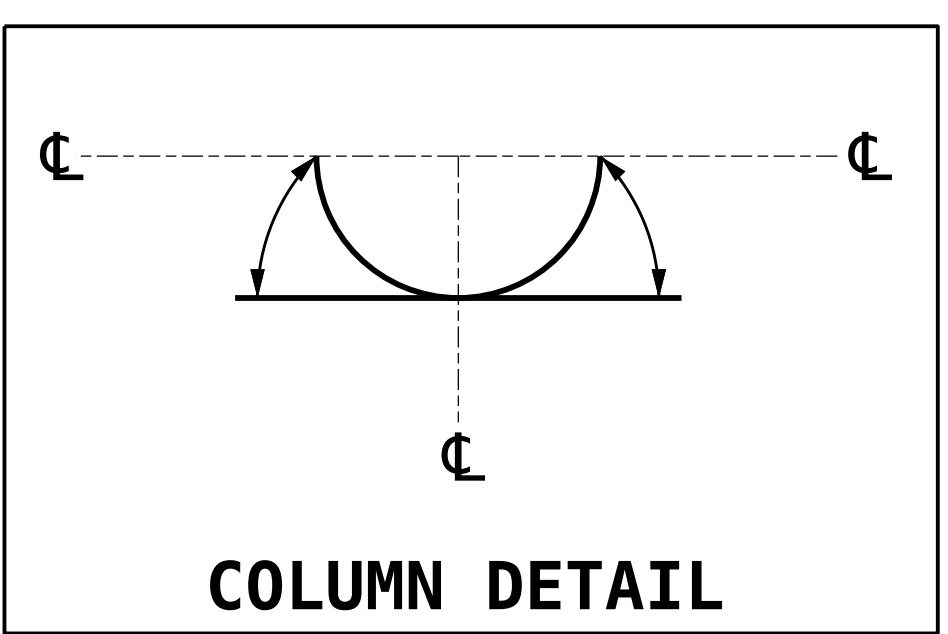

**COLUMN DETAIL**

AS-BUILT REPAIR QUANTITY TABLE				
BENT 3 SPAN C FACE	QUANTITIES			
	ESTIMATE		ACTUAL	
SHOTCRETE REPAIRS	AREA SF	VOLUME CF	AREA SF	VOLUME CF
CAP	23.7	11.9		
COLUMN	1.0	0.5		
CONCRETE REPAIRS	AREA SF	VOLUME CF	AREA SF	VOLUME CF
CAP	5.4	2.7		
COLUMN	0	0		
EPOXY RESIN INJECTION		LINEAR FT		LINEAR FT
CAP		0		
COLUMN		0		
EPOXY COATING		AREA SF		AREA SF
CAP		141.0		

VALUES IN CHART REPRESENT ESTIMATED REPAIR TOTALS AFTER REMOVAL OF UNSOUND CONCRETE, MIN. OF 1" BEHIND REBAR AND MIN. 2" CLEAR TO SAWCUT. SEE "TYPICAL CAP AND COLUMN REPAIR DETAILS" SHEET.

**NOTES**

REPAIR LOCATIONS AND ESTIMATE OF QUANTITIES ARE GIVEN BASED ON THE BEST INFORMATION AVAILABLE. IF ADDITIONAL REPAIRS NOT SHOWN ON THE DRAWINGS ARE DEEMED NECESSARY BY THE ENGINEER, THE ENGINEER SHALL NOTE ON THE DRAWINGS THE APPROXIMATE LOCATION AND DESCRIPTION OF THE REPAIRS AND ENTER THE ACTUAL QUANTITIES INTO THE AS-BUILT REPAIR QUANTITY TABLE.

CLEAN AND REMOVE DEBRIS FROM THE TOP OF THE CAP AND APPLY EPOXY PROTECTIVE COATING. EPOXY COATING SHALL BE APPLIED TO THE TOP SURFACE OF THE CAP. THE CONTRACTOR SHALL NOT COAT THE AREA OF THE CAP BENEATH THE MASONRY PLATES. FOR EPOXY COATING, SEE SPECIAL PROVISIONS.

SHOTCRETE REPAIRS MAYBE SUBSTITUTED IN LIEU OF CONCRETE REPAIRS WITH THE APPROVAL OF THE ENGINEER.

FOR CAP AND COLUMN REPAIR DETAILS, SEE "TYPICAL CAP AND COLUMN REPAIR DETAILS" SHEET.

FOR SHOTCRETE REPAIRS, SEE SPECIAL PROVISIONS.

FOR CONCRETE REPAIRS, SEE SPECIAL PROVISIONS.

FOR EPOXY RESIN INJECTION, SEE SPECIAL PROVISIONS.

PROJECT NO. **I-5950**  
**DAVIDSON** COUNTY  
 BRIDGE NO. **280146**

SHEET 1 OF 2

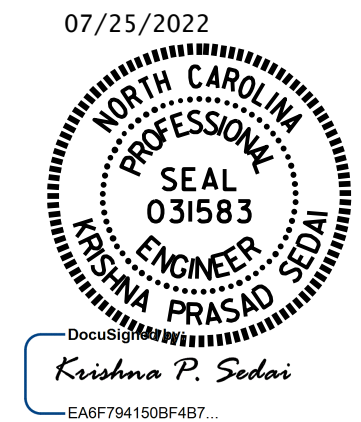

STATE OF NORTH CAROLINA  
 DEPARTMENT OF TRANSPORTATION  
 RALEIGH  
**SUBSTRUCTURE REPAIR  
 BENT 3  
 SPAN C FACE**

REVISIONS						SHEET NO.
NO.	BY:	DATE:	NO.	BY:	DATE:	S3-13
1			3			TOTAL SHEETS
2			4			15

DOCUMENT NOT CONSIDERED FINAL UNLESS ALL SIGNATURES COMPLETED

DRAWN BY : E. BAYISSA DATE : 04/2022  
 CHECKED BY : A. SORSENGINH DATE : 04/2022

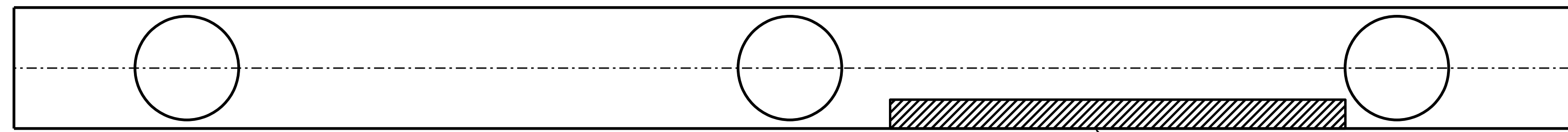

**PLAN - BOTTOM OF CAP**

10.9 SQ. FT. SHOTCRETE REPAIR

SPAN D  
SPAN C

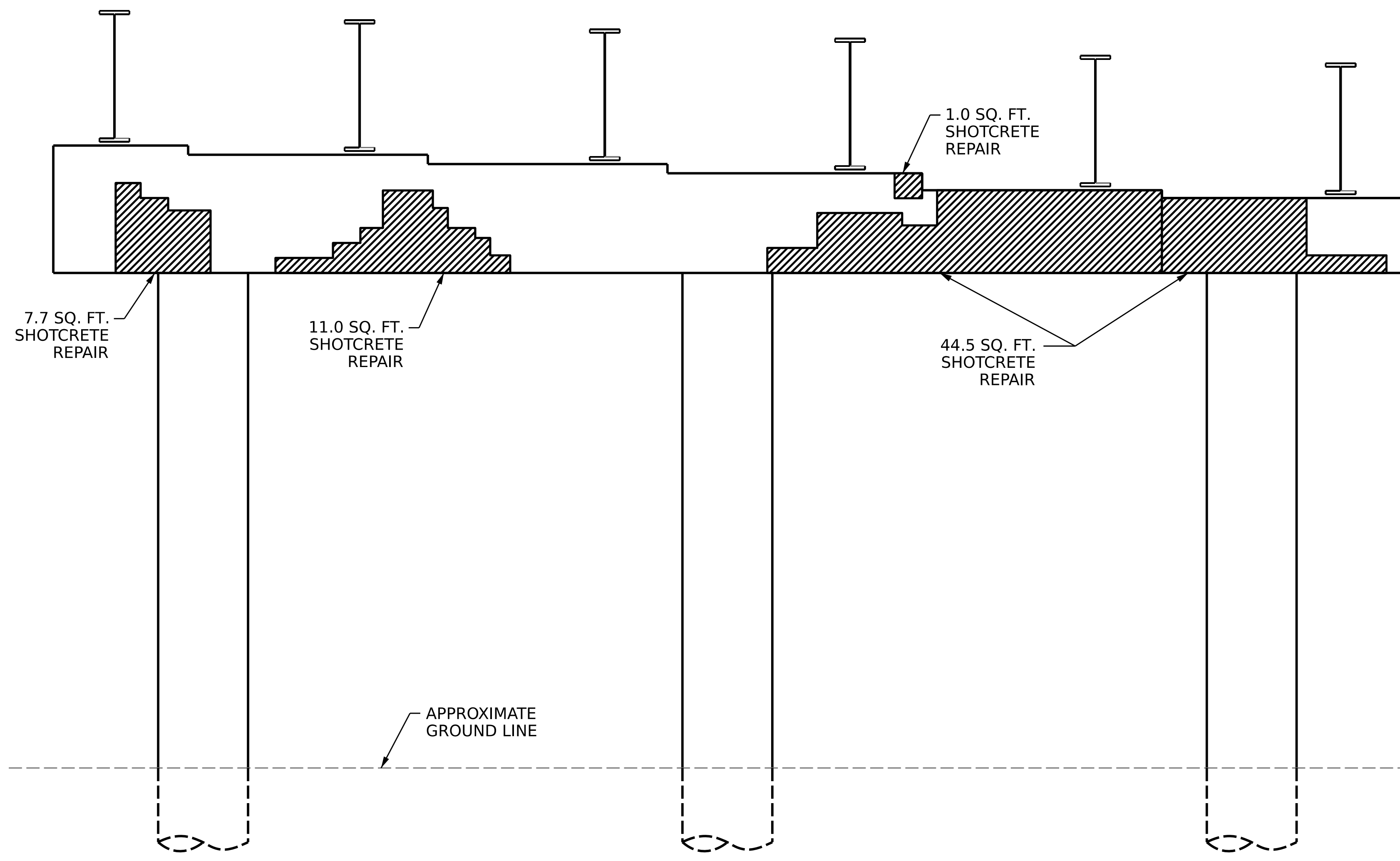

**ELEVATION**

SPAN D | SPAN C

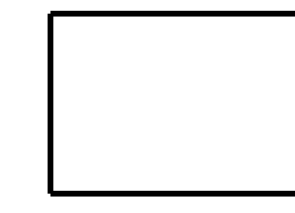

**END VIEW**

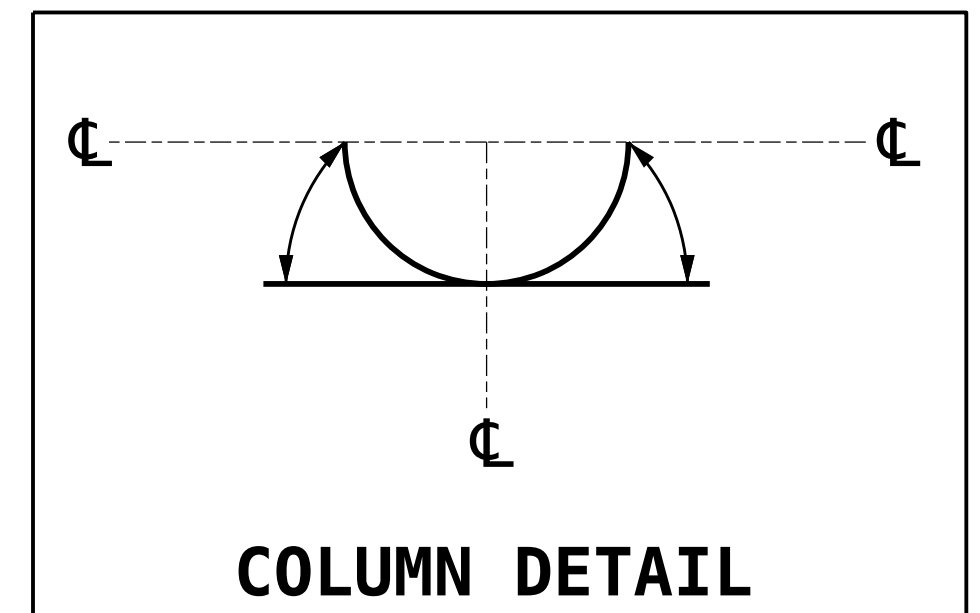

**COLUMN DETAIL**

**AS-BUILT REPAIR QUANTITY TABLE**

BENT 3 SPAN D FACE	QUANTITIES			
	ESTIMATE		ACTUAL	
SHOTCRETE REPAIRS	AREA SF	VOLUME CF	AREA SF	VOLUME CF
CAP	75.1	37.6		
COLUMN	0	0		
CONCRETE REPAIRS	AREA SF	VOLUME CF	AREA SF	VOLUME CF
CAP		0		
COLUMN		0		
EPOXY RESIN INJECTION		LINEAR FT		LINEAR FT
CAP		0		
COLUMN		0		

VALUES IN CHART REPRESENT ESTIMATED REPAIR TOTALS AFTER REMOVAL OF UNSOUND CONCRETE, MIN. OF 1" BEHIND REBAR AND MIN. 2" CLEAR TO SAWCUT. SEE "TYPICAL CAP AND COLUMN REPAIR DETAILS" SHEET.

**NOTES**

REPAIR LOCATIONS AND ESTIMATE OF QUANTITIES ARE GIVEN BASED ON THE BEST INFORMATION AVAILABLE. IF ADDITIONAL REPAIRS NOT SHOWN ON THE DRAWINGS ARE DEEMED NECESSARY BY THE ENGINEER, THE ENGINEER SHALL NOTE ON THE DRAWINGS THE APPROXIMATE LOCATION AND DESCRIPTION OF THE REPAIRS AND ENTER THE ACTUAL QUANTITIES INTO THE AS-BUILT REPAIR QUANTITY TABLE.

SHOTCRETE REPAIRS MAYBE SUBSTITUTED IN LIEU OF CONCRETE REPAIRS WITH THE APPROVAL OF THE ENGINEER.

FOR CAP AND COLUMN REPAIR DETAILS, SEE "TYPICAL CAP AND COLUMN REPAIR DETAILS" SHEET.

FOR SHOTCRETE REPAIRS, SEE SPECIAL PROVISIONS.

FOR CONCRETE REPAIRS, SEE SPECIAL PROVISIONS.

FOR EPOXY RESIN INJECTION, SEE SPECIAL PROVISIONS.

- SHOTCRETE REPAIR AREA
- CONCRETE REPAIR AREA
- EPOXY RESIN INJECTION

PROJECT NO. **I-5950**  
**DAVIDSON** COUNTY  
 BRIDGE NO. **280146**

SHEET 2 OF 2

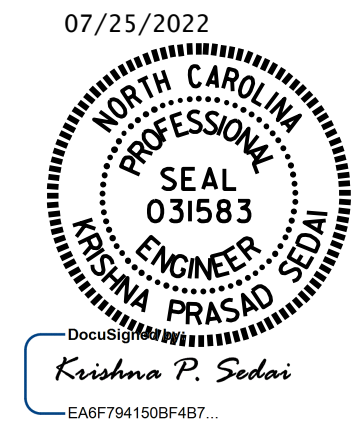

STATE OF NORTH CAROLINA  
 DEPARTMENT OF TRANSPORTATION  
 RALEIGH  
**SUBSTRUCTURE REPAIR  
 BENT 3  
 SPAN D FACE**

REVISIONS						SHEET NO.
NO.	BY:	DATE:	NO.	BY:	DATE:	S3-14
1			3			TOTAL SHEETS
2			4			15

DOCUMENT NOT CONSIDERED FINAL UNLESS ALL SIGNATURES COMPLETED

DRAWN BY : E. BAYISSA DATE : 04/2022  
 CHECKED BY : A. SORSENGINH DATE : 04/2022

### AS-BUILT REPAIR QUANTITY TABLE

REPAIRS - END BENT 2	QUANTITIES			
	ESTIMATE		ACTUAL	
SHOTCRETE REPAIRS	AREA SF	VOLUME CF	AREA SF	VOLUME CF
CAP	0	0		
CURTAIN WALL	0	0		
WINGWALL	0	0		
CONCRETE REPAIRS	AREA SF	VOLUME CF	AREA SF	VOLUME CF
CAP	0	0		
CURTAIN WALL	0	0		
WINGWALL	0	0		
SLOPE PROTECTION REPAIR (CLASS B CONCRETE)	8.0	2.7		
EPOXY RESIN INJECTION		LINEAR FT		LINEAR FT
CAP		7.5		
CURTAIN WALL		0		
WINGWALL				
EPOXY COATING		AREA SF		AREA SF
CAP		70.5		

VALUES IN CHART REPRESENT ESTIMATED REPAIR TOTALS AFTER REMOVAL OF UNSOUND CONCRETE, MIN. OF 1" BEHIND REBAR AND MIN. 2" CLEAR TO SAWCUT. SEE "TYPICAL CAP AND COLUMN REPAIR DETAILS" SHEET.

#### NOTES

REPAIR LOCATIONS AND ESTIMATE OF QUANTITIES ARE GIVEN BASED ON THE BEST INFORMATION AVAILABLE. IF ADDITIONAL REPAIRS NOT SHOWN ON THE DRAWINGS ARE DEEMED NECESSARY BY THE ENGINEER, THE ENGINEER SHALL NOTE ON THE DRAWINGS THE APPROXIMATE LOCATION AND DESCRIPTION OF THE REPAIRS AND ENTER THE ACTUAL QUANTITIES INTO THE AS-BUILT REPAIR QUANTITY TABLE.

CLEAN AND REMOVE DEBRIS FROM THE TOP OF THE CAP AND APPLY EPOXY PROTECTIVE COATING. EPOXY COATING SHALL BE APPLIED TO THE TOP SURFACE OF THE CAP. THE CONTRACTOR SHALL NOT COAT THE AREA OF THE CAP BENEATH THE MASONRY PLATES. FOR EPOXY COATING, SEE SPECIAL PROVISIONS.

SHOTCRETE REPAIRS MAYBE SUBSTITUTED IN LIEU OF CONCRETE REPAIRS WITH THE APPROVAL OF THE ENGINEER.

FOR CRACK REPAIR ON SLOPE PROTECTION, SAW CUT 1 FOOT EACH SIDE OF CRACK LINE, REMOVE CONCRETE, PREPARE SOIL SUBGRADE WITH PROPER COMPACTION THEN FILL WITH CLASS B CONCRETE TO COMPLETE THE REPAIR.

FOR CAP AND COLUMN REPAIR DETAILS, SEE "TYPICAL CAP AND COLUMN REPAIR DETAILS" SHEET.

FOR SHOTCRETE REPAIRS, SEE SPECIAL PROVISIONS.

FOR CONCRETE REPAIRS, SEE SPECIAL PROVISIONS.

FOR EPOXY RESIN INJECTION, SEE SPECIAL PROVISIONS.

PROJECT NO. **I-5950**

**DAVIDSON** COUNTY

BRIDGE NO. **280146**

STATE OF NORTH CAROLINA  
DEPARTMENT OF TRANSPORTATION  
RALEIGH

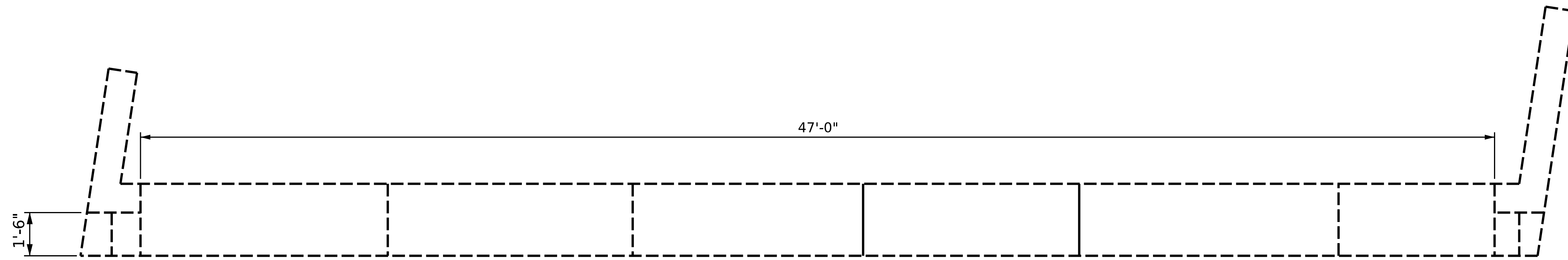
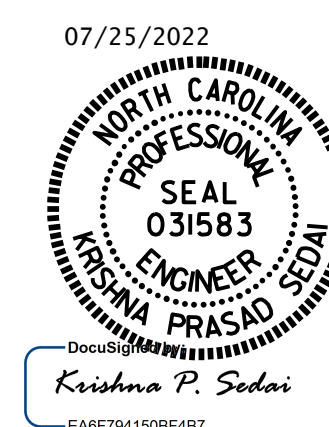

**SUBSTRUCTURE REPAIR  
END BENT 2**

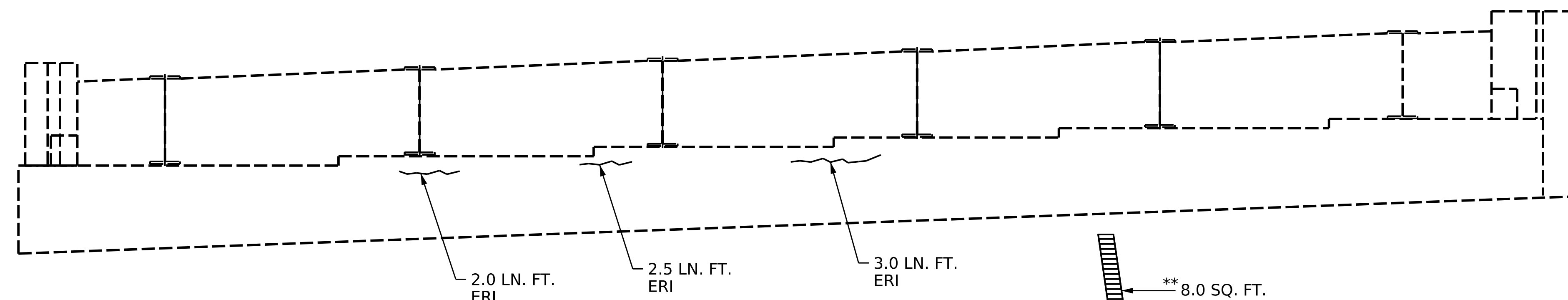

**PLAN**

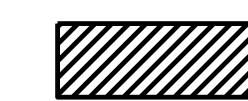

**ELEVATION**

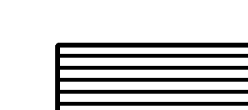
-  SHOTCRETE REPAIR AREA
-  CONCRETE REPAIR AREA
-  EPOXY RESIN INJECTION
-  CONCRETE REPAIR AREA CLASS B

DRAWN BY : E. BAYISSA DATE : 04/2022  
CHECKED BY : A. SORSENGINH DATE : 04/2022

1/25/2022  
S:\DPG3\I-5950\Final Plans\403\_041\_I5950\_SMU.EB2\_S15\_280146.dgn  
ksedai

DOCUMENT NOT CONSIDERED  
FINAL UNLESS ALL  
SIGNATURES COMPLETED

REVISIONS						SHEET NO.
NO.	BY:	DATE:	NO.	BY:	DATE:	S3-15
1			3			TOTAL SHEETS
2			4			15

**NOTES**

GENERAL DRAWING INFORMATION IS TAKEN FROM THE ORIGINAL PLANS AND THE ROUTINE INSPECTION REPORT DATED 4/27/2020.

BRIDGE ORIENTATION CONFORMS TO THE EXISTING BRIDGE PLANS/ROUTINE INSPECTION.

**SCOPE OF WORK**

PARTIALLY REMOVE TOP OF BRIDGE DECK CONCRETE BY SCARIFICATION AND SHOTBLASTING METHODS.

OVERLAY PREPARED TOP OF BRIDGE DECK WITH POLYMER CONCRETE (PC).

REMOVE EXISTING JOINT MATERIAL AND INSTALL POURABLE SILICONE JOINTS.

GROOVE PC BRIDGE DECK.

EPOXY RESIN INJECTION OF CONCRETE CRACKS.

REMOVE DEBRIS FROM TOP OF EXISTING END BENT CAPS, AND APPLY EPOXY COATING.

REMOVE UNSOUND CONCRETE AND PROPERLY PREPARE EXISTING END BENT AND BENT AREAS FOR SHOTCRETE AND CONCRETE REPAIRS.

PROPERLY PREPARE SPALLED AREAS IN EXISTING END BENTS AND BENTS, AND PERFORM SHOTCRETE AND CONCRETE REPAIRS.

CLEAN AND PAINT EXISTING STEEL STRUCTURE.

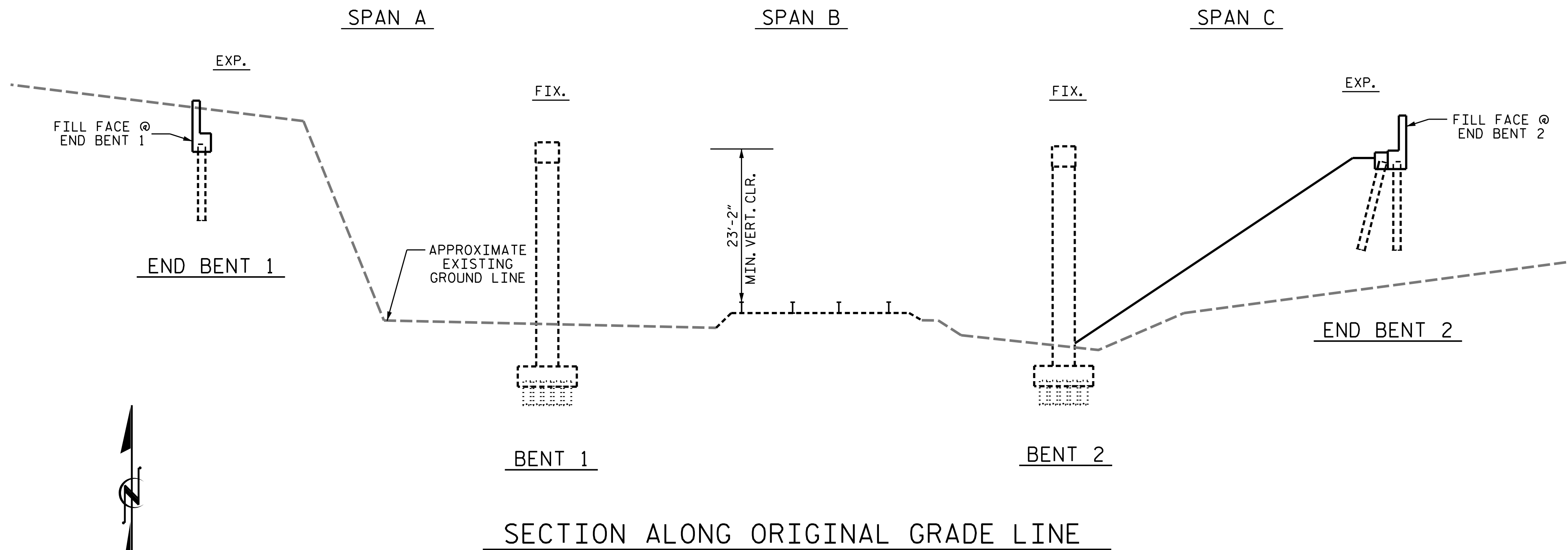

I HEREBY CERTIFY THAT THIS STRUCTURE WAS REHABILITATED ACCORDING TO THESE PLANS OR AS NOTED HEREIN.

RESIDENT ENGINEER \_\_\_\_\_ DATE \_\_\_\_\_

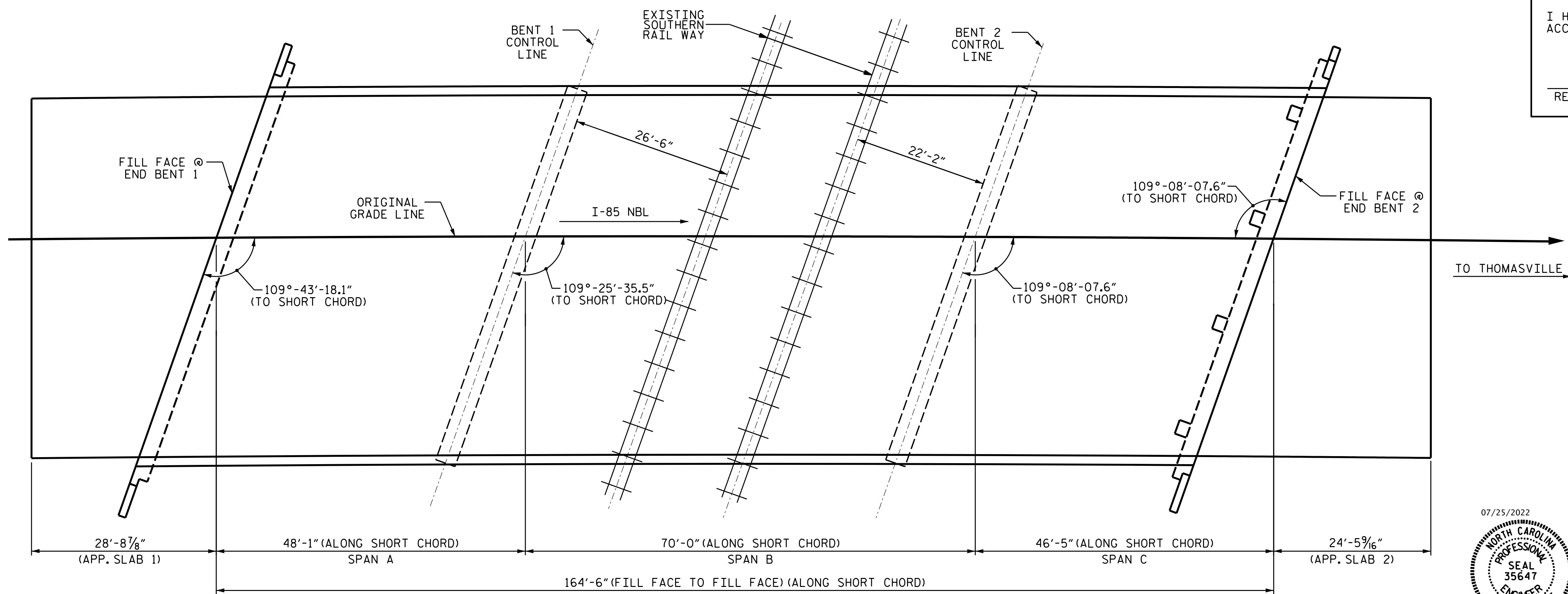

TO THOMASVILLE

PROJECT NO. I-5950  
DAVIDSON COUNTY  
 BRIDGE NO. 280147  
 SHEET 1 OF 2 MILE POST #MN-320.890

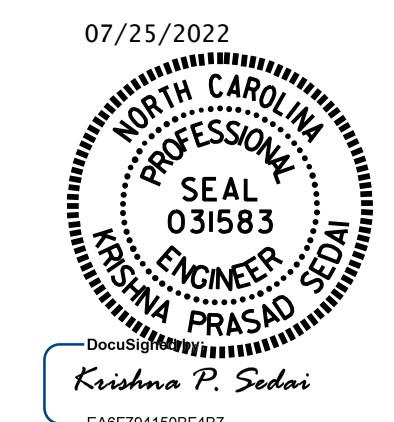
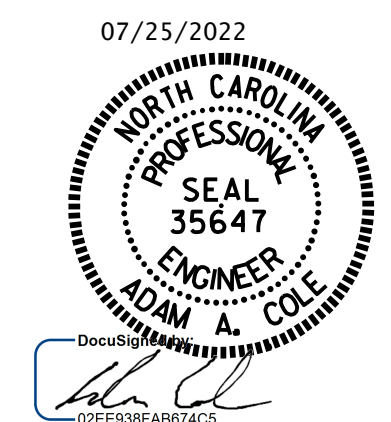

STATE OF NORTH CAROLINA  
 DEPARTMENT OF TRANSPORTATION  
 RALEIGH  
**GENERAL DRAWING**  
 FOR BRIDGE ON I-85 NBL  
 OVER SOUTHERN RAILROAD

DRAWN BY : M. G. SHAIKH DATE : 08/2020  
 CHECKED BY : E. BAYISSA/A. SORSENGINH DATE : 04/2022

REVISIONS						SHEET NO.
NO.	BY:	DATE:	NO.	BY:	DATE:	S4-01
1			3			TOTAL SHEETS
2			4			14



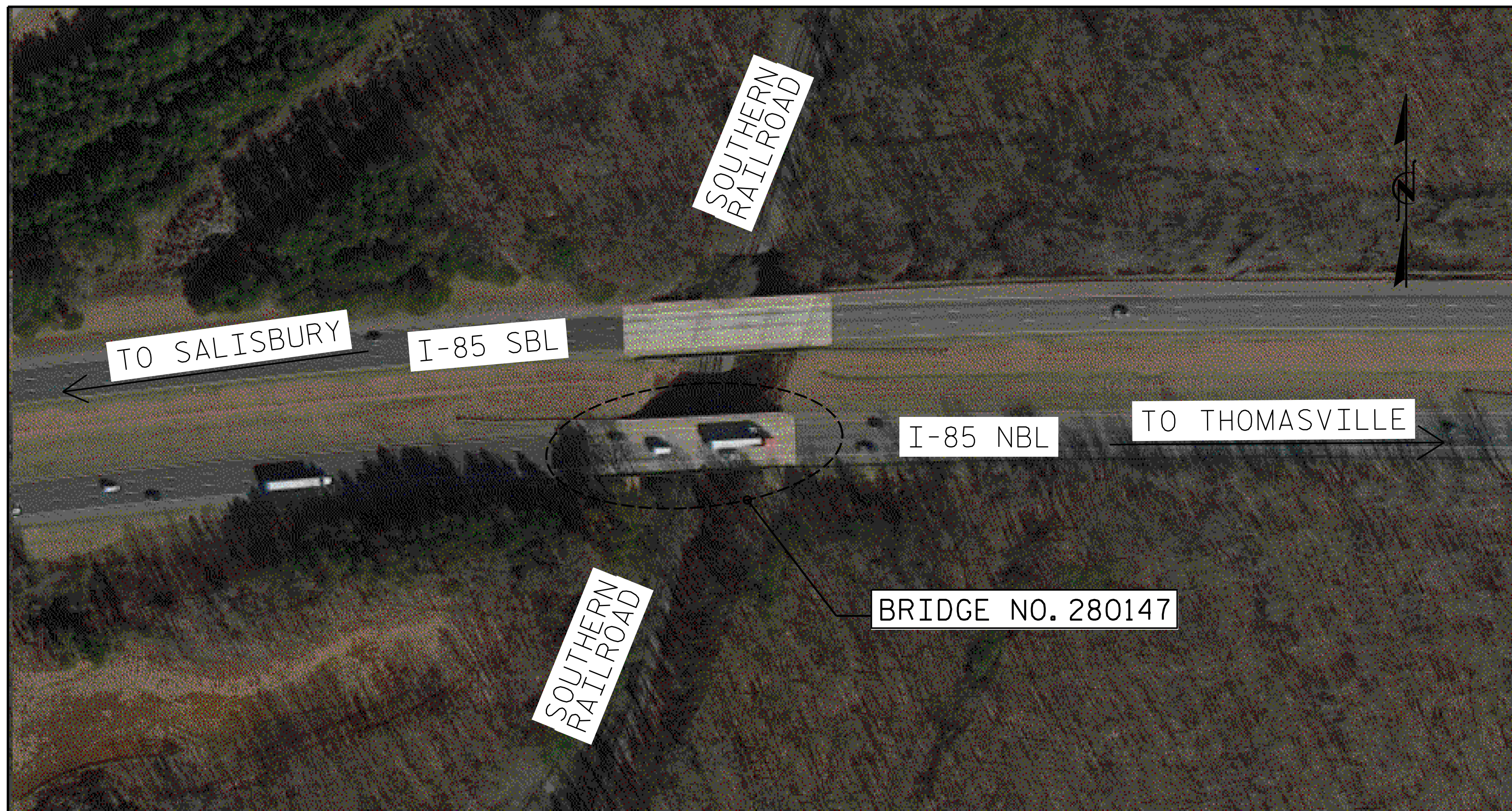

**LOCATION SKETCH**

**BRIDGE COORDINATES**

BRIDGE No.	LATITUDE	LONGITUDE
280147	35°-46'-35.79"	80°-17'-55.71"

**TOTAL BILL OF MATERIAL**

BRIDGE NO. 280147	GROOVING BRIDGE FLOORS	POLLUTION CONTROL	CLASS II SURFACE PREPARATION	CONCRETE REPAIRS	SHOTCRETE REPAIRS	EPOXY RESIN INJECTION	CLEANING & REPAINTING OF BRIDGE NO. 280147	PAINTING CONTAINMENT FOR BRIDGE NO. 280147	POURABLE SILICONE JOINT SEALANT	POLYESTER POLYMER CONCRETE MATERIALS	EPOXY POLYMER CONCRETE MATERIALS (ALTERNATE)	EPOXY COATING	CONCRETE DECK REPAIR FOR POLYMER CONCRETE OVERLAY	PLACING & FINISHING POLYMER CONCRETE OVERLAY	SCARIFYING BRIDGE DECK	SHOTBLASTING BRIDGE DECK
	SQ. FT.	LUMP SUM	SQ. YDS.	CU. FT.	CU. FT.	LIN. FT.	LUMP SUM	LUMP SUM	LIN. FT.	CU. YDS.	CU. YDS.	SQ. FT.	SQ. YDS.	SQ. YDS.	SQ. YDS.	SQ. YDS.
TOTAL	11,336	LUMP SUM	16.7	17.7	0.6	23.5	LUMP SUM	LUMP SUM	118.8	46.5	46.5	1,292.7	16.7	1,340	1,340	1,340

**NOTES:**

INFORMATION INDICATED ON THE LOCATION SKETCH SHALL BE CONSIDERED GENERAL INFORMATION ONLY. THE CONTRACTOR SHALL CONFIRM, THROUGH OTHER SOURCES, SPECIFIC INFORMATION REGARDING BRIDGES, ROADWAYS, UTILITIES, THE SURROUNDING AREA, AND ANY OTHER ASPECTS THAT MAY BE NECESSARY TO PERFORM AND COMPLETE THE PROJECT.

EXISTING DIMENSIONS AND BRIDGE CONDITION ARE FROM THE BEST INFORMATION AVAILABLE. THE CONTRACTOR SHALL FIELD VERIFY THE INFORMATION SHOWN ON THE PLANS AND NOTIFY THE ENGINEER IF ACTUAL DIMENSIONS AND CONDITIONS DIFFER.

THE CONTRACTOR SHALL HAVE NO CLAIM WHATSOEVER AGAINST THE DEPARTMENT FOR ANY DELAYS OF ADDITIONAL COST INCURRED BASED ON DIFFERENCES BETWEEN WHAT IS SHOWN ON THE PLANS AND THE ACTUAL CONDITIONS AT THE PROJECT SITE.

IT IS THE CONTRACTOR'S RESPONSIBILITY TO FOLLOW ALL STATE AND FEDERAL SAFETY REQUIREMENTS.

FOR CONTROL OF TRAFFIC AND LIMITS ON PHASING OF CONSTRUCTION, SEE TRANSPORTATION MANAGEMENT PLANS.

EXISTING JOINTS AND DECK DRAINS SHALL BE SEALED PRIOR TO BEGINNING SURFACE PREPARATIONS OF THE BRIDGE DECK. THE CONTRACTOR SHALL TAKE CARE THAT ANY CONSTRUCTION DEBRIS THAT COLLECTS IN THE DRAINS IS CONTAINED. DRAINS IN SHOULDERS OF ADJACENT TRAVEL LANE(S) SHALL BE KEPT FREE AND CLEAR OF DEBRIS.

LONGITUDINAL CONSTRUCTION JOINTS OF OVERLAYS SHALL BE LOCATED ALONG THE CENTERLINE OR EDGE OF TRAVEL LANES.

FOR POURABLE SILICONE JOINT SEALANT, SEE SPECIAL PROVISIONS.

FOR EPOXY RESIN INJECTION, SEE SPECIAL PROVISIONS.

FOR CONCRETE REPAIRS, SEE SPECIAL PROVISIONS.

FOR SHOTCRETE REPAIRS, SEE SPECIAL PROVISIONS.

FOR SUBMITTAL OF WORKING DRAWINGS, SEE SPECIAL PROVISIONS.

FOR FALSEWORK AND FORMWORK, SEE SPECIAL PROVISIONS.

FOR CRANE SAFETY, SEE SPECIAL PROVISIONS.

FOR SCARIFYING BRIDGE DECK, SHOTBLASTING BRIDGE DECK AND CLASS II SURFACE PREPARATION, SEE OVERLAY SURFACE PREPARATION FOR POLYMER CONCRETE SPECIAL PROVISION.

FOR CONCRETE DECK REPAIR FOR PC OVERLAY, PC MATERIALS, MAND PLACING AND FINISHING PC OVERLAY, SEE POLYMER CONCRETE BRIDGE DECK OVERLAY SPECIAL PROVISION.

THE CONTRACTOR SHALL PERFORM ALL WORK WITH CARE SO THAT THE EXISTING STRUCTURE WHICH IS TO REMAIN IN PLACE WILL NOT BE DAMAGED. IF THE CONTRACTOR DAMAGES ANY PART OF THE EXISTING STRUCTURE WHICH IS TO REMAIN IN PLACE, THE DAMAGED AREA SHALL BE REPAIRED OR REPLACED IN A MANNER SATISFACTORY TO THE ENGINEER AT NO ADDITIONAL COST TO THE DEPARTMENT.

SHOTCRETE REPAIRS MAY BE REPLACED WITH CONCRETE REPAIRS WITH THE APPROVAL OF THE ENGINEER.

THE CONTRACTOR SHALL FIELD VERIFY THE EXISTING JOINT OPENING PRIOR TO ORDERING JOINT SEAL MATERIAL. IF ACTUAL JOINT OPENING VARIES FROM THE OPENING INDICATED IN DETAIL BY MORE THAN 1/4", NOTIFY ENGINEER. REVISION TO THE JOINT SEAL SIZE MIGHT BE NECESSARY.

FOR GROUT FOR STRUCTURES, SEE SPECIAL PROVISIONS.

THE EXISTING BRIDGE DECK SHALL BE REPAIRED AS SHOWN ON THE PLANS OR AS DETERMINED BY THE ENGINEER AFTER SCARIFICATION AND PRIOR TO THE SURFACE PREPARATION AND APPLICATION OF THE PC OVERLAY. UNLESS OTHERWISE APPROVED, SUCH LOCATIONS SHALL BE REPAIRED WITH POLYMER CONCRETE.

FOR EPOXY COATING AND DEBRIS REMOVAL, SEE SPECIAL PROVISIONS.

WORK ON THE BRIDGE SHALL BE PERFORMED SO AS NOT TO ALLOW DEBRIS TO FALL BELOW. THE CONTRACTOR SHALL SUBMIT PLANS FOR CONSTRUCTION IN ACCORDANCE WITH ARTICLE 402-2 OF THE STANDARD SPECIFICATIONS AND THE PROJECT SPECIAL PROVISIONS.

PRIOR TO BEGINNING WORK, THE CONTRACTOR SHALL SUBMIT FOR REVIEW AND APPROVAL A COMPLETE SEQUENCE OF TASKS FOR EACH OPERATION AFFECTING THE BRIDGE SURFACE AND/OR TRAFFIC.

THE CONTRACTOR SHALL PROVIDE INDEPENDENT ASSURANCE SAMPLES OF REINFORCING STEEL AS FOLLOWS: FOR PROJECTS REQUIRING UP TO 400 TONS OF REINFORCING STEEL, ONE 30 INCH SAMPLE OF EACH SIZE BAR USED, AND FOR PROJECTS REQUIRING OVER 400 TONS OF REINFORCING STEEL, TWO 30 INCH SAMPLES OF EACH SIZE BAR USED. THE SAMPLE BARS SHOULD COME FROM STEEL ACTUALLY USED IN THE PROJECT AND THE SAMPLE BARS SHOULD BE REPLACED BY SPLICED BARS AS SPECIFIED IN THE SAMPLE BAR REPLACEMENT CHART. PAYMENT FOR THE SAMPLE BARS AND REPLACEMENT REINFORCING STEEL SHALL BE CONSIDERED INCIDENTAL TO VARIOUS PAY ITEMS.

FOR PAINTING CONTAINMENT, POLLUTION CONTROL AND CLEANING & REPAINTING BRIDGE, SEE SPECIAL PROVISIONS.

FOR ANCHOR BOLT NUT REPLACEMENT AND TIGHTENING, SEE SPECIAL PROVISIONS.

PROJECT NO. I-5950  
DAVIDSON COUNTY  
 BRIDGE NO. 280147

SHEET 2 OF 2

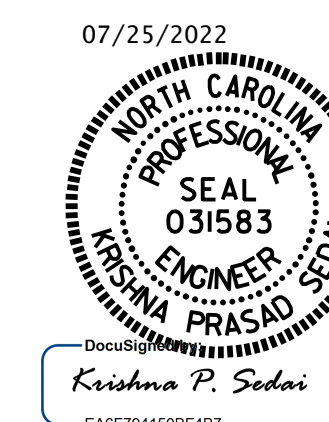

STATE OF NORTH CAROLINA  
 DEPARTMENT OF TRANSPORTATION  
 RALEIGH  
**GENERAL DRAWING**  
 FOR BRIDGE ON I-85 NBL  
 OVER SOUTHERN RAILROAD

DRAWN BY : M. G. SHAIKH DATE : 08/2020  
 CHECKED BY : E. BAYISSA/A. SORSENGINH DATE : 08/2020

DOCUMENT NOT CONSIDERED  
 FINAL UNLESS ALL  
 SIGNATURES COMPLETED

REVISIONS						SHEET NO.
NO.	BY:	DATE:	NO.	BY:	DATE:	S4-02
1			3			TOTAL SHEETS
2			4			14

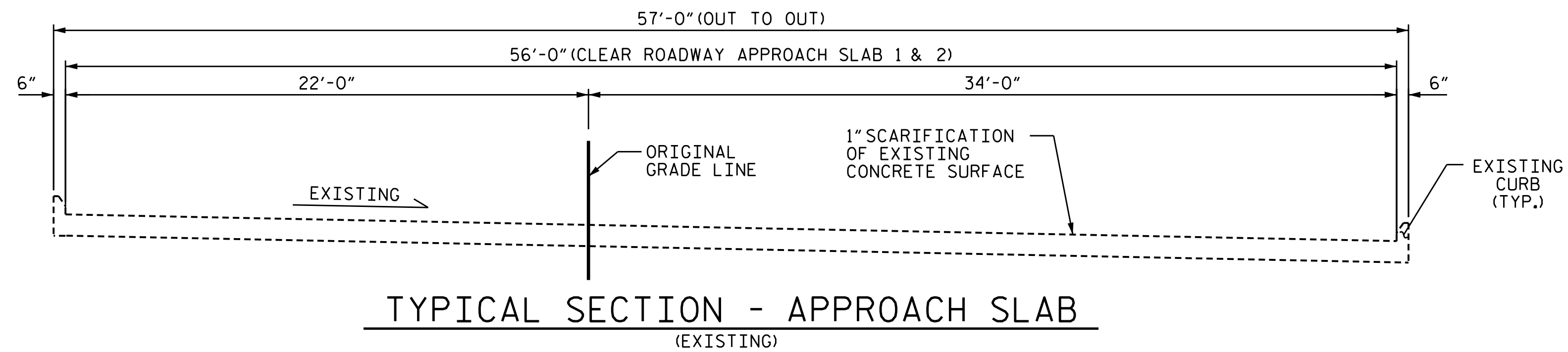

TYPICAL SECTION - APPROACH SLAB  
(EXISTING)

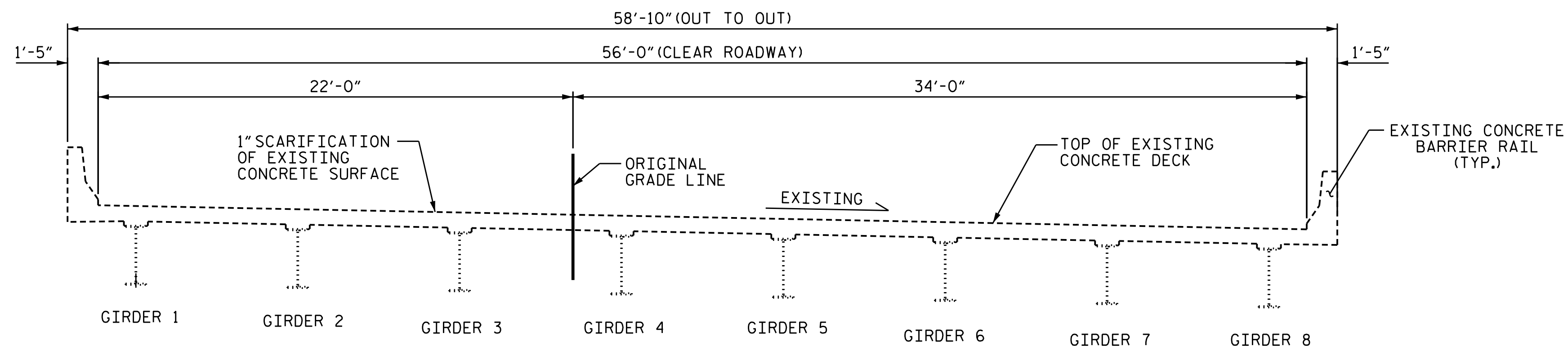

TYPICAL SECTION  
(EXISTING)

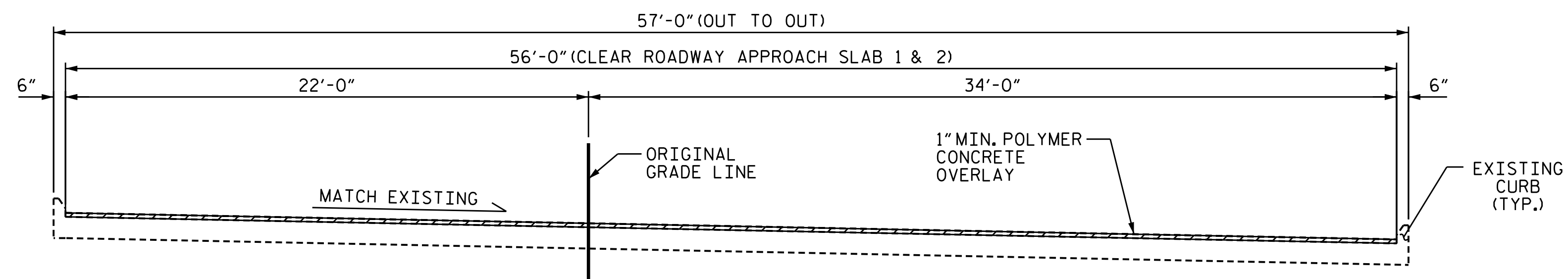

TYPICAL SECTION - APPROACH SLAB  
(PROPOSED)

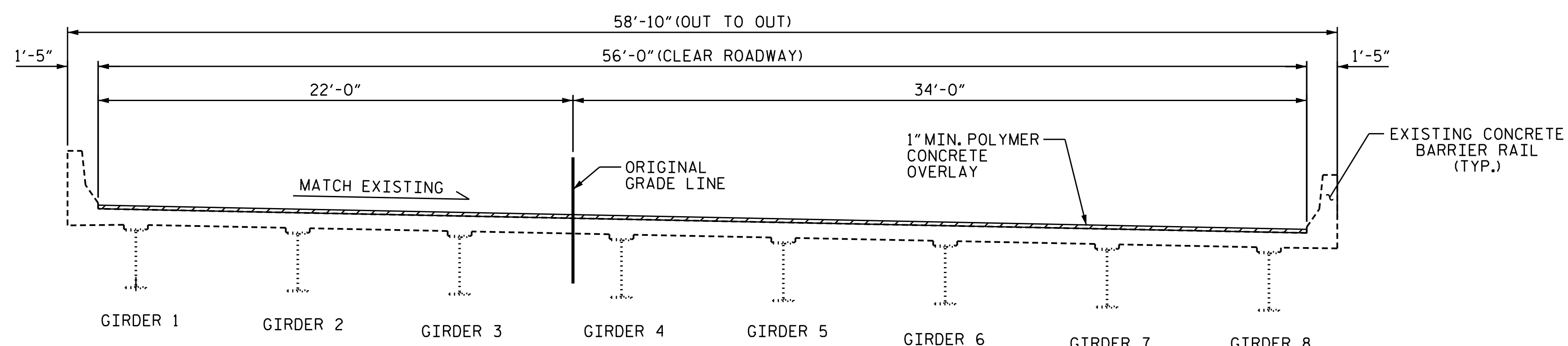

TYPICAL SECTION  
(PROPOSED)

NOTES

SEE TRANSPORTATION MANAGEMENT PLANS FOR LANE WIDTHS, SEQUENCING AND OTHER TRAFFIC CONTROL MEASURES FOR STAGING OF POLYMER CONCRETE (PC) OVERLAY SYSTEM AND SURFACE PREPARATION.

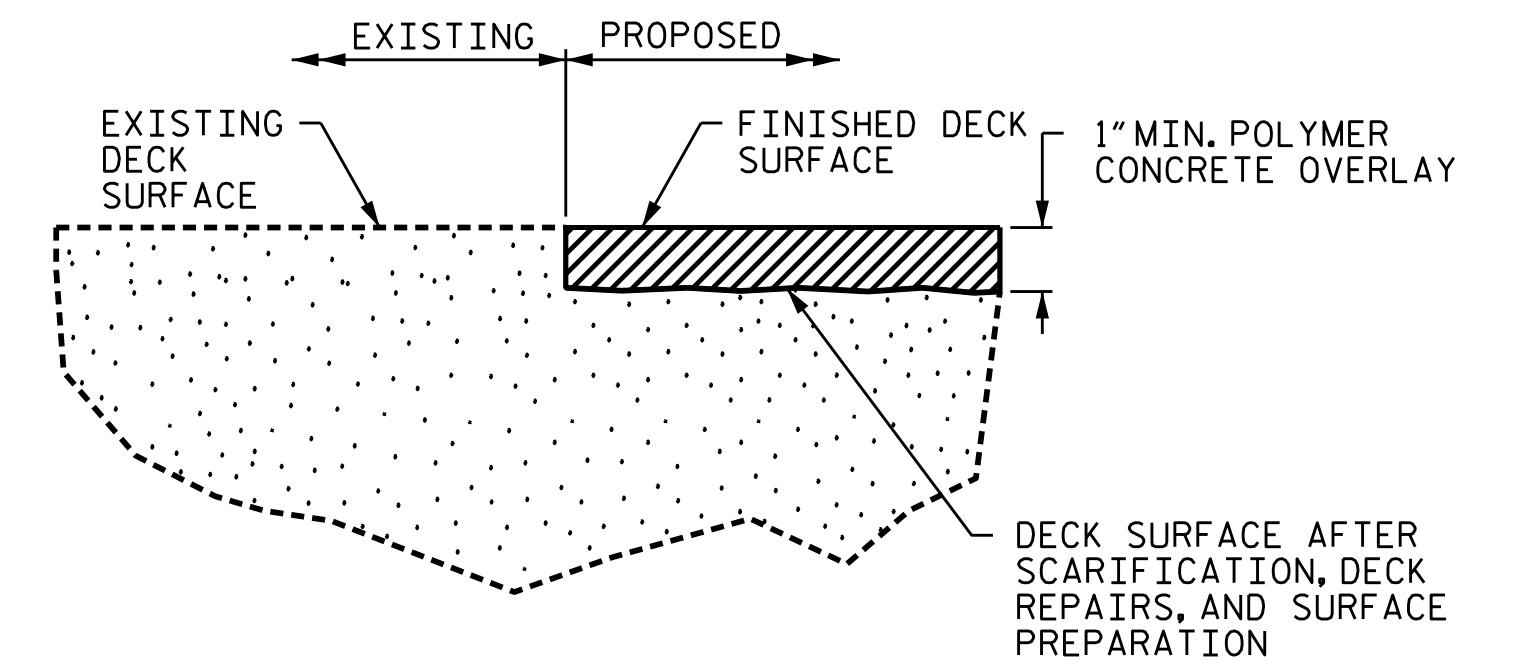

DETAIL FOR POLYMER CONCRETE OVERLAY

FINISHED SURFACE ELEVATION SHALL MATCH EXISTING CONCRETE SURFACE ELEVATION. ACTUAL THICKNESS OF PC OVERLAY MAY VARY.

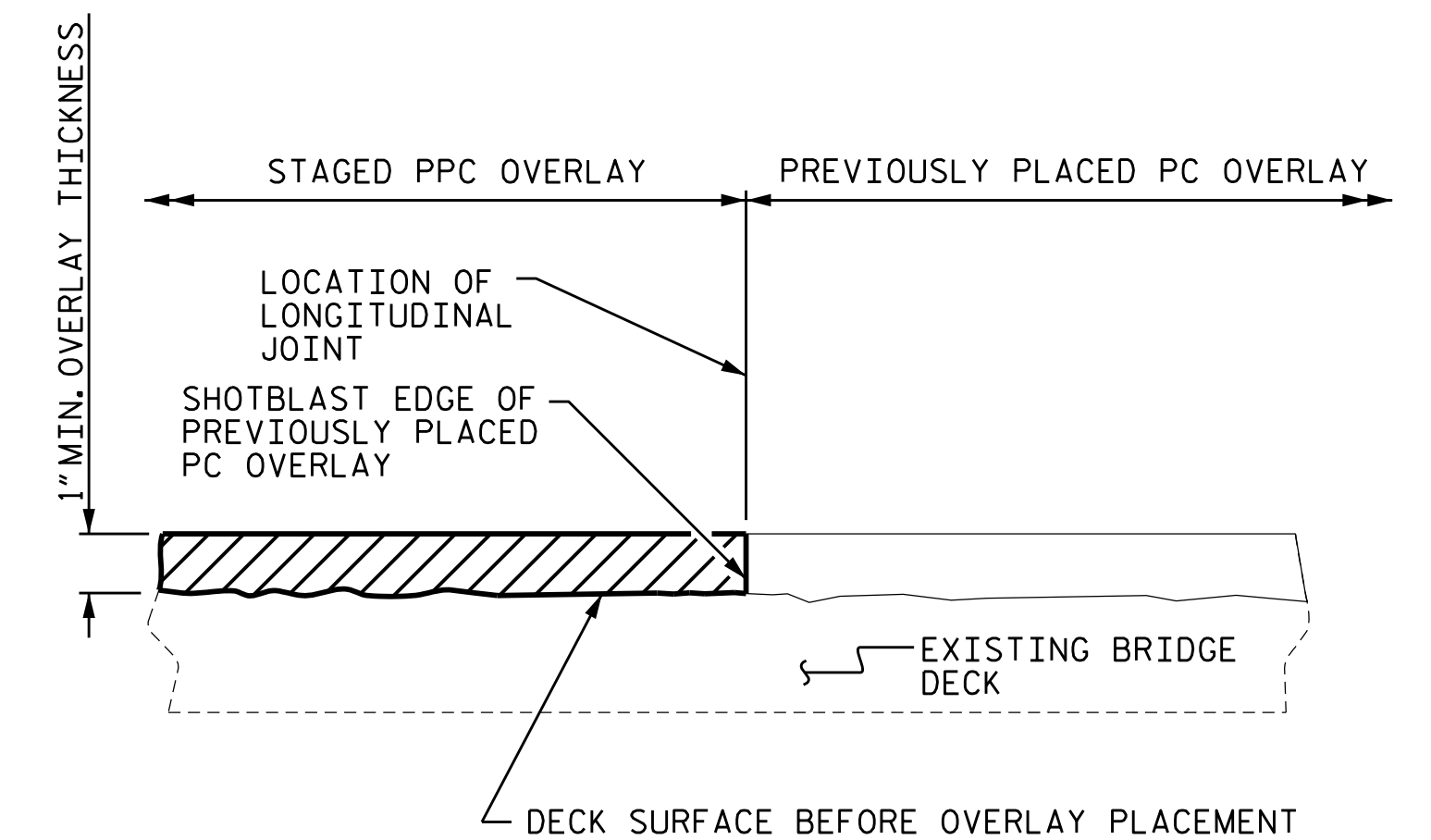

STAGED PC OVERLAY JOINT  
(AS NEEDED)

PROJECT NO. I-5950  
DAVIDSON COUNTY  
BRIDGE NO. 280147

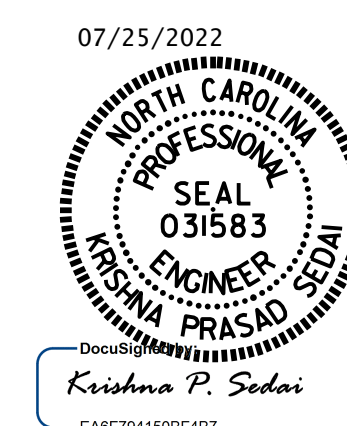

STATE OF NORTH CAROLINA  
DEPARTMENT OF TRANSPORTATION  
RALEIGH  
SUPERSTRUCTURE  
TYPICAL SECTION  
AND PC  
OVERLAY DETAILS

DRAWN BY : M. G. SHAIKH DATE : 09/2020  
CHECKED BY : A. SORSENGINH DATE : 10/2020

7/25/2022  
S:\DPS3\I-5950\Final Plans\404.005\_I5950\_SMU.TS.S03.280147.dgn  
ksedal

DOCUMENT NOT CONSIDERED  
FINAL UNLESS ALL  
SIGNATURES COMPLETED

REVISIONS						SHEET NO.
NO.	BY:	DATE:	NO.	BY:	DATE:	S4-03
1			3			TOTAL SHEETS
2			4			14

**NOTES:**



REPAIR LOCATIONS AND ESTIMATE OF QUANTITIES ARE BASED ON THE BEST INFORMATION AVAILABLE. IF ADDITIONAL REPAIRS NOT SHOWN ON THE DRAWINGS ARE DEEMED NECESSARY BY THE ENGINEER, THE ENGINEER WILL NOTE ON THE DRAWINGS THE APPROXIMATE LOCATIONS AND DESCRIPTION OF THE REPAIRS AND ENTER THE ACTUAL QUANTITIES INTO THE AS-BUILT REPAIR QUANTITY TABLE.

FOR CONCRETE DECK REPAIR FOR PC OVERLAY, PC MATERIALS, AND PLACING AND FINISHING PC OVERLAY, SEE POLYMER CONCRETE BRIDGE DECK OVERLAY SPECIAL PROVISION.

FOR SECTION A-A, SEE "JOINT DETAILS" SHEET.

TOP OF DECK SURFACE REPAIR QUANTITIES REPRESENT ESTIMATED VALUES OF CLASS II SURFACE PREPARATION AND CONCRETE DECK REPAIR AFTER REMOVAL OF UNSOUND CONCRETE (MIN. 2" CLEAR TO SAWCUT). SEE CONCRETE FOR DECK REPAIR SPECIAL PROVISION.

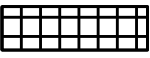
FOR SCARIFYING BRIDGE DECK, SHOTBLASTING BRIDGE DECK AND CLASS II SURFACE PREPARATION, SEE OVERLAY SURFACE PREPARATION FOR POLYMER CONCRETE SPECIAL PROVISION.

-  CLASS II SURFACE PREPARATION
-  SHOTCRETE REPAIR
-  CONCRETE REPAIR
-  EPOXY RESIN INJECTION (ERI)

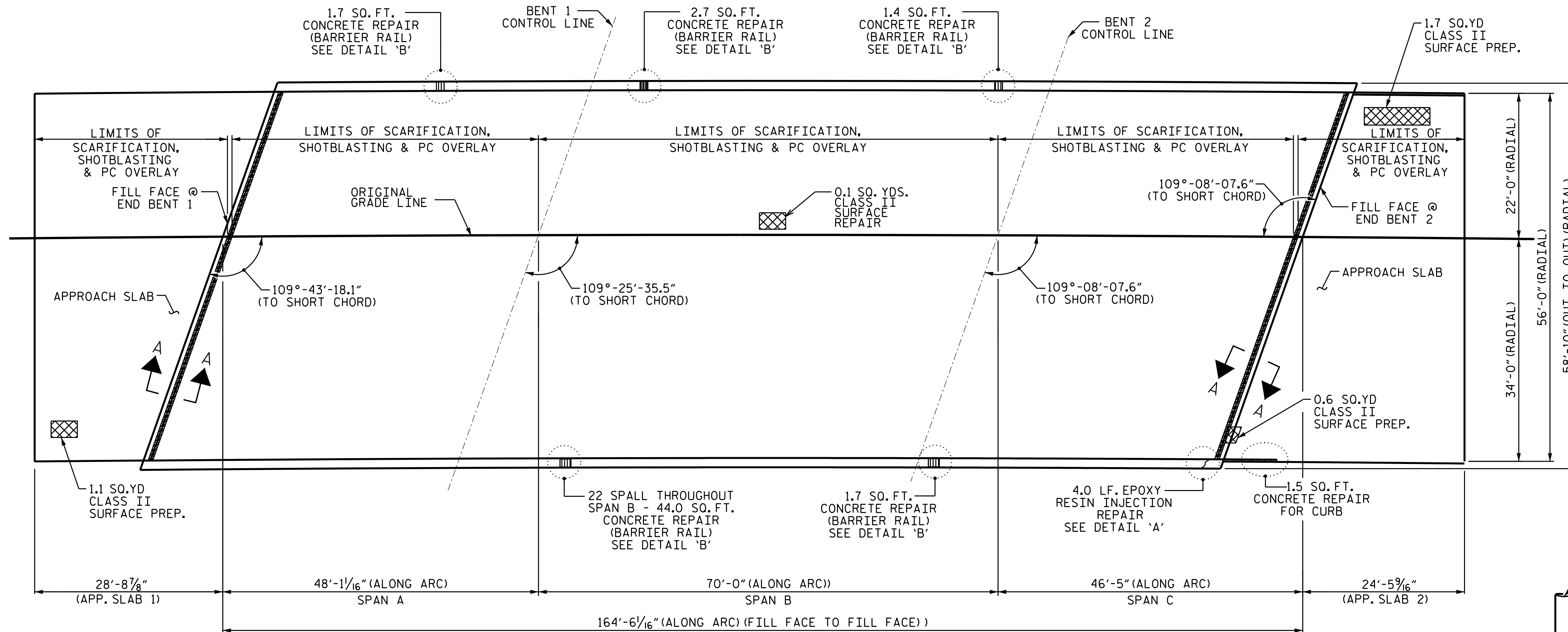

PLAN OF SPANS

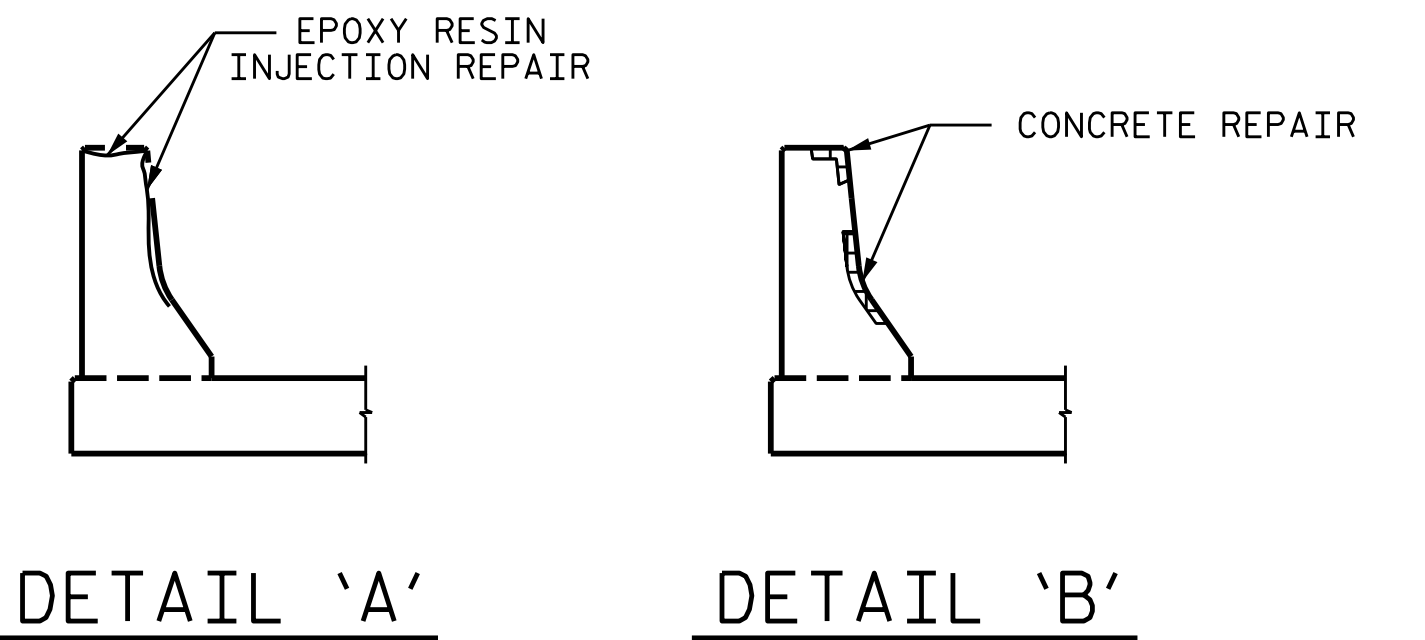

AS-BUILT REPAIR QUANTITY TABLE

TOP OF DECK REPAIRS	APPROACH SLAB 1		SPAN A		SPAN B		SPAN C		APPROACH SLAB 2			
	ESTIMATE	ACTUAL	ESTIMATE	ACTUAL	ESTIMATE	ACTUAL	ESTIMATE	ACTUAL	ESTIMATE	ACTUAL		
SCARIFYING BRIDGE DECK	162.2 SQ. YDS.		295.3 SQ. YDS.		435.5 SQ. YDS.		284.8 SQ. YDS.		162.2 SQ. YDS.			
SHOTBLASTING BRIDGE DECK	162.2 SQ. YDS.		295.3 SQ. YDS.		435.5 SQ. YDS.		284.8 SQ. YDS.		162.2 SQ. YDS.			
CLASS II SURFACE PREPARATION	4.4 SQ. YDS.		3.3 SQ. YDS.		0.1 SQ. YDS.		3.3 SQ. YDS.		5.6 SQ. YDS.			
CONCRETE DECK REPAIR FOR PC OVERLAY	4.4 SQ. YDS.		3.3 SQ. YDS.		0.1 SQ. YDS.		3.3 SQ. YDS.		5.6 SQ. YDS.			
POLYMER CONCRETE MATERIALS	5.6 CU. YDS.		10.3 CU. YDS.		15.1 CU. YDS.		9.9 CU. YDS.		5.6 CU. YDS.			
PLACING & FINISHING PC OVERLAY	162.2 SQ. YDS.		295.3 SQ. YDS.		435.5 SQ. YDS.		284.8 SQ. YDS.		162.2 SQ. YDS.			
GROOVING BRIDGE FLOOR	1344.0 SQ. FT.		2513.0 SQ. FT.		3710.0 SQ. FT.		2425.0 SQ. FT.		1344.0 SQ. FT.			
EPOXY RESIN INJECTION	0.0 LIN. FT.		0.0 LIN. FT.		0.0 LIN. FT.		4.0 LIN. FT.		0.0 LIN. FT.			
CONCRETE REPAIRS	ESTIMATE		ACTUAL		ESTIMATE		ACTUAL		ESTIMATE		ACTUAL	
	AREA SQ. FT.	VOLUME CU. FT.	AREA SQ. FT.	VOLUME CU. FT.	AREA SQ. FT.	VOLUME CU. FT.	AREA SQ. FT.	VOLUME CU. FT.	AREA SQ. FT.	VOLUME CU. FT.	AREA SQ. FT.	VOLUME CU. FT.
CONCRETE BARRIER RAIL	0.0	0.0			1.7	0.6			48.1	16.0		
CURB	0.0	0.0			0.0	0.0			0.0	0.0		

PROJECT NO. I-5950  
DAVIDSON COUNTY  
 BRIDGE NO. 280147

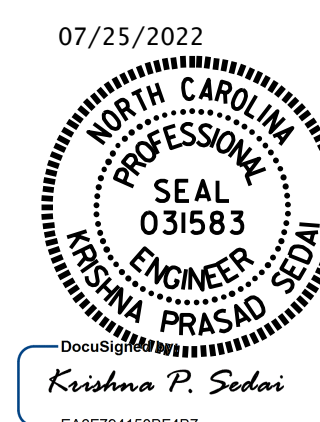

STATE OF NORTH CAROLINA  
 DEPARTMENT OF TRANSPORTATION  
 RALEIGH  
**DECK SURFACE REPAIR  
 AND  
 APPROACH SLAB**

DRAWN BY : M. G. SHAIKH DATE : 09/2020  
 CHECKED BY : E. BAYISSA DATE : 03/2022

NO.	REVISIONS			SHEET NO.
	BY:	DATE:	NO.	
1			3	S4-04
2			4	

DOCUMENT NOT CONSIDERED FINAL UNLESS ALL SIGNATURES COMPLETED

**NOTE**

THE CONTRACTOR SHALL FIELD VERIFY THE EXISTING JOINT OPENING PRIOR TO ORDERING JOINT SEAL MATERIAL. IF ACTUAL JOINT OPENING VARIES FROM THE OPENING INDICATED IN DETAIL BY MORE THAN 1/4", NOTIFY ENGINEER. REVISION TO THE JOINT SEAL SIZE MIGHT BE NECESSARY.

FINAL JOINT SEALS SHALL NOT BE INSTALLED UNTIL THE OVERLAY IS COMPLETE.

THE CONTRACTOR SHALL TAKE CARE DURING JOINT REHAB OPERATIONS NOT TO DROP ANY MATERIAL BELOW THE BRIDGE WITHOUT PROTECTIVE DEVICES BELOW TO CATCH THE MATERIAL. ANY MATERIAL THAT FALLS BELOW THE BRIDGE SHALL BE CONTAINED, REMOVED AND DISPOSED OF BY THE CONTRACTOR AT NO COST TO THE DEPARTMENT. IF THE ENGINEER DETERMINES THAT THE PROTECTIVE DEVICES ARE NOT ADEQUATE OR NOT BEING EMPLOYED, THE WORK SHALL BE SUSPENDED UNTIL ADEQUATE PROTECTION IS PROVIDED.

THE CONTRACTOR WILL NOT BE PERMITTED TO FORM THE JOINTS IN LIEU OF SAWING THE JOINT.

DURING THE JOINT INSTALLATION PROCEDURE, THE JOINT AND SURROUNDING AREA SHALL BE KEPT CLEAN AND FREE OF DEBRIS.

FOR POURABLE SILICONE JOINT SEALANT, SEE SPECIAL PROVISIONS.

THE MANUFACTURER IS TO PROVIDE THE NOMINAL UNCOMPRESSED SEAL WIDTH OF THE BACKER ROD FOR THE EXISTING JOINT SIZE AND ACCOMMODATE THE MINIMUM EXPANSION SHOWN ON THE PLANS.

A MANUFACTURER'S CERTIFIED TRAINED REPRESENTATIVE SHALL BE PRESENT DURING THE INSTALLATION OF THE FIRST JOINT OF THE PROJECT, OR UNTIL THE ENGINEER IS SATISFIED WITH THE INSTALLATION PROCESS.

THE INSTALLATION OF THE JOINT SEAL SHALL BE WATERTIGHT.

FINAL SURFACE OF THE JOINT DEMOLITION AREA PRIOR TO PLACEMENT OF CONCRETE REPAIR MATERIAL SHOULD BE REASONABLY FLAT AND LEVEL. ENGINEER SHALL DETERMINE THE ACCEPTABILITY OF THE SURFACE PRIOR TO PLACEMENT OF REPAIR CONCRETE.

POURABLE SILICONE JOINT SEALANT SHALL BE INSTALLED AS PER THE MANUFACTURER'S RECOMMENDATION.

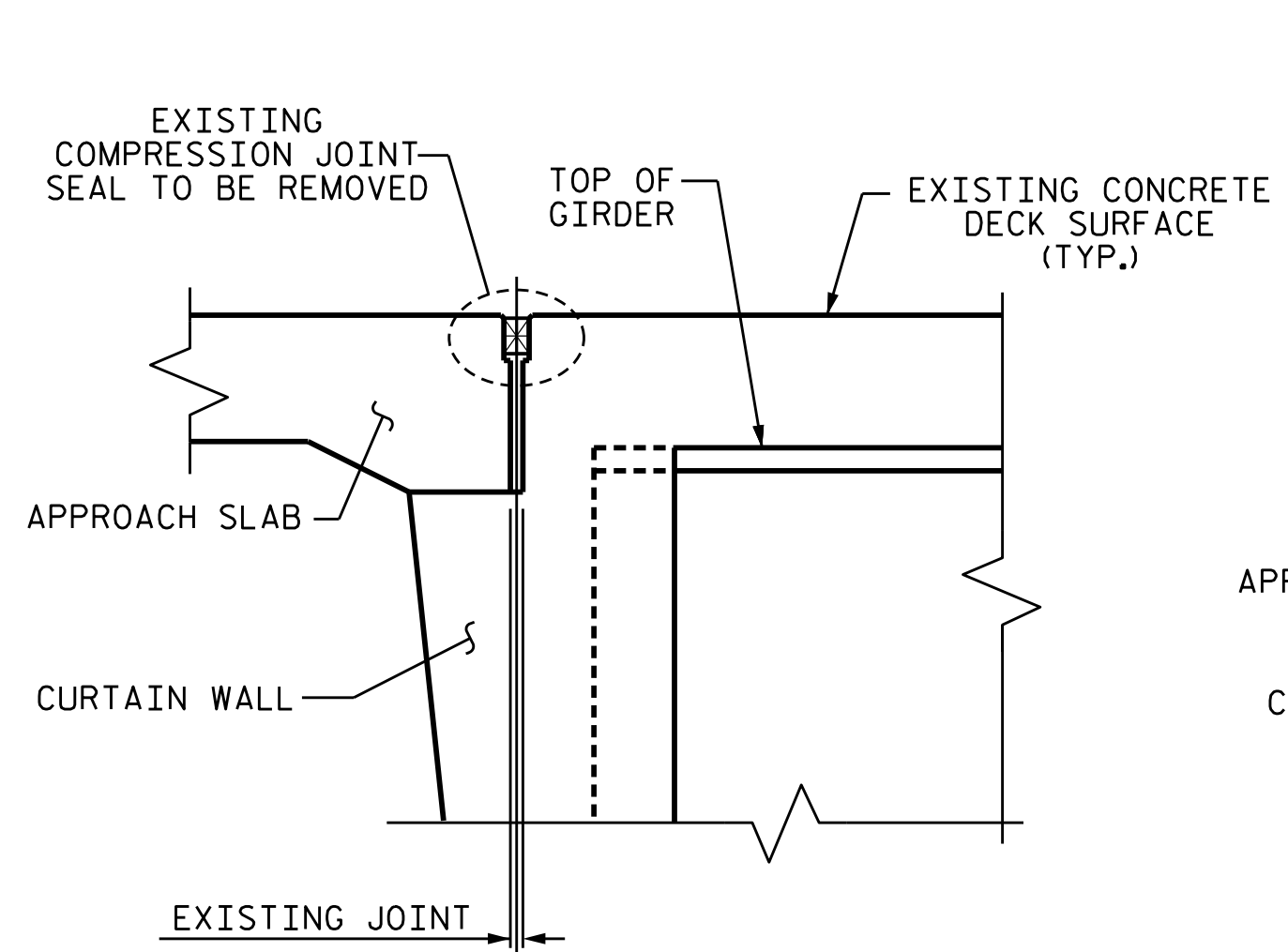

EXISTING JOINT

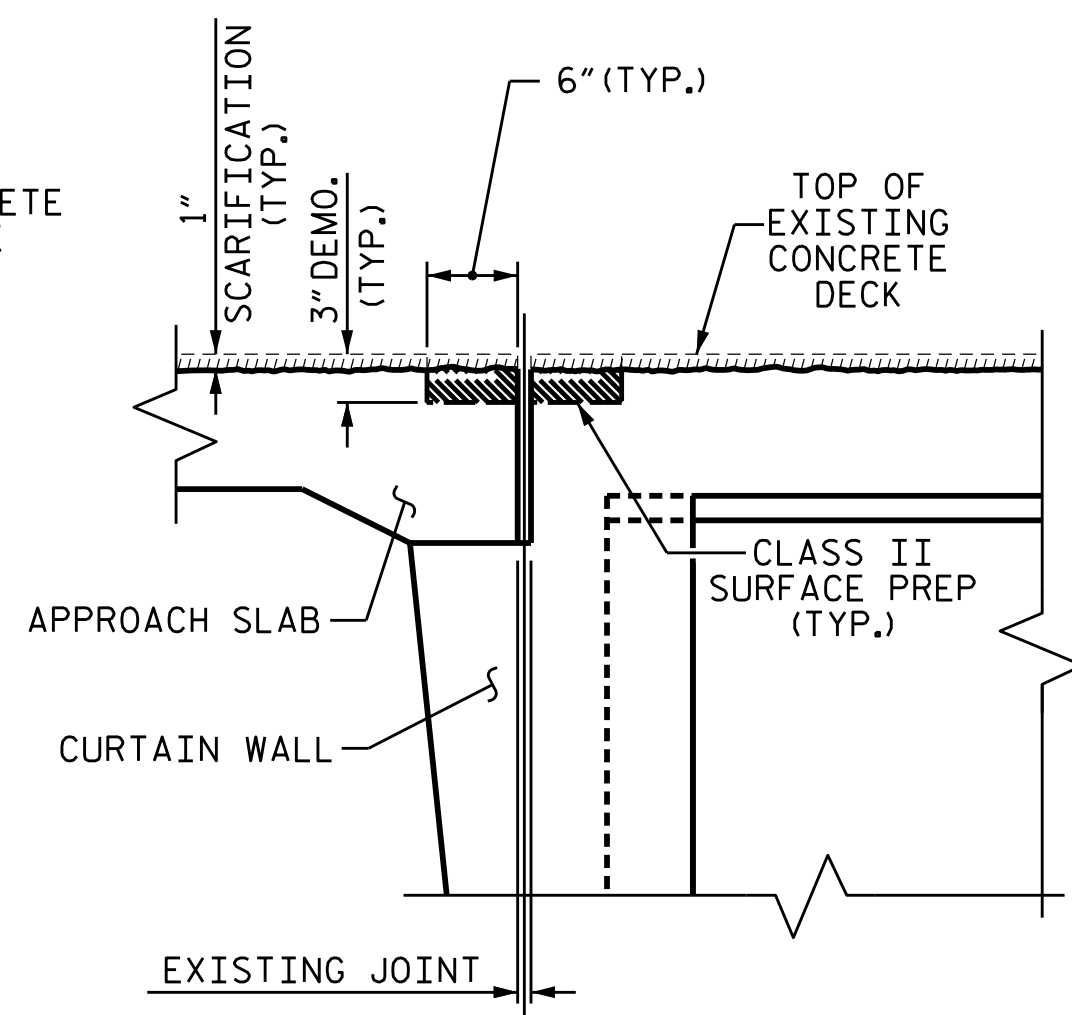

MINIMUM EXISTING JOINT DEMOLITION & SCARIFICATION

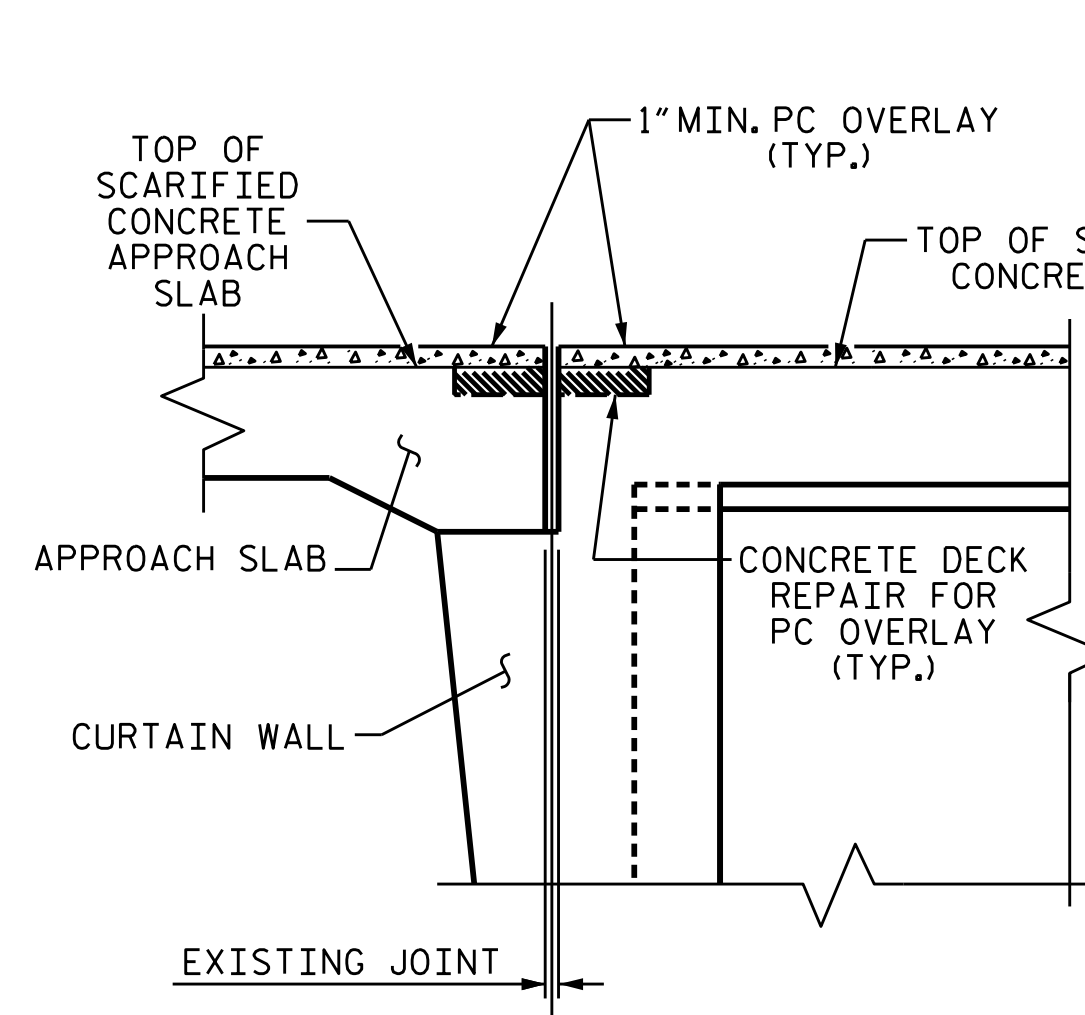

PROPOSED JOINT PRE-SAWED & PC OVERLAY

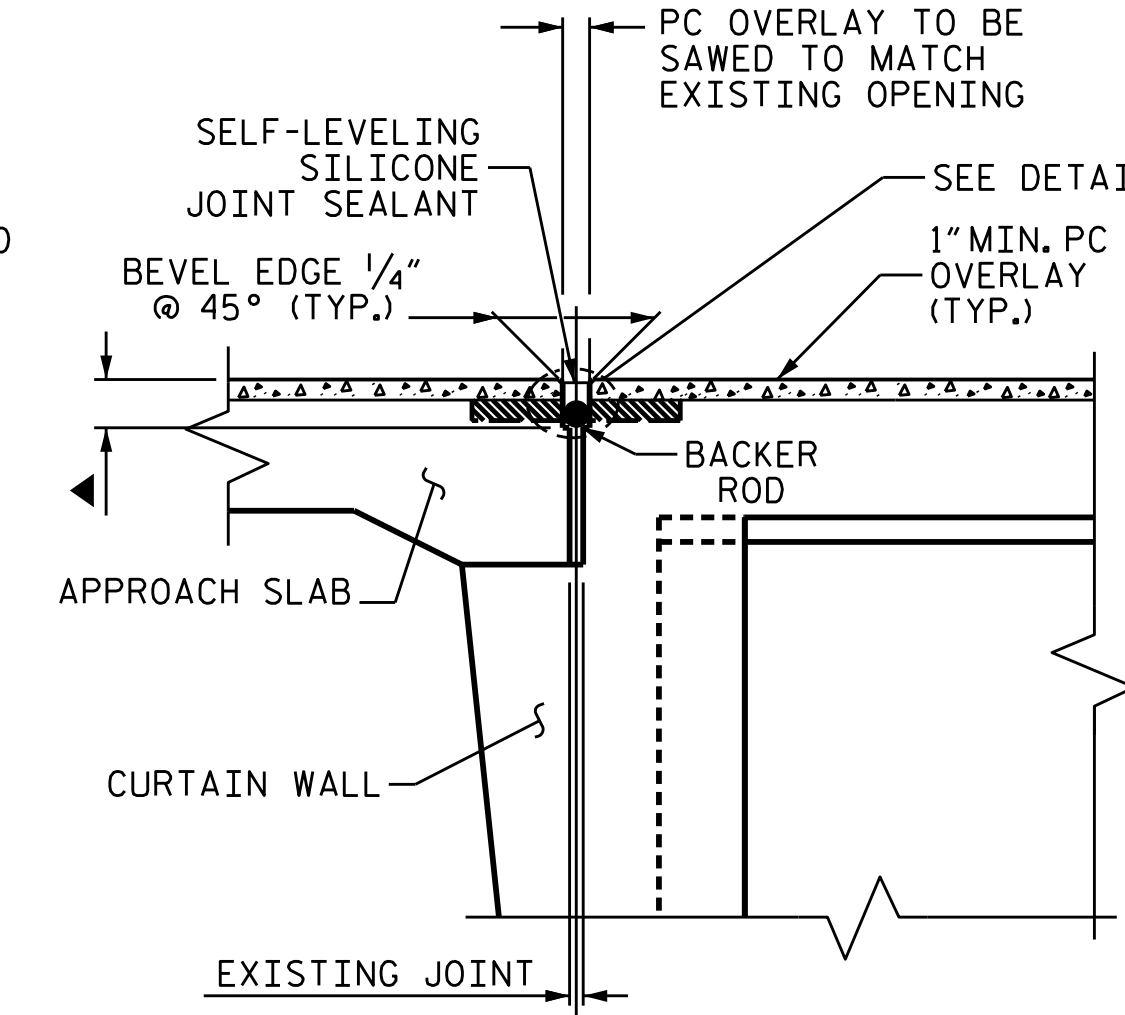

PROPOSED POURABLE SILICONE JOINT SEALANT

▲ SAW CUT SHALL BE 1" BELOW THE BOTTOM OF FOAM JOINT SEAL. SEE MANUFACTURER RECOMMENDATIONS

JOINT INSTALLATION SEQUENCE AT END BENTS

SECTION A-A

CONTRACTOR TO FIELD VERIFY WIDTH OF EXISTING JOINT AT APPROACH SLABS FOR INSTALLATION OF THE PROPER SIZE BACKER ROD.

\*NON-SAG SILICONE JOINT SEALANT TO BE PLACED AND ALLOWED TO SET PRIOR TO PLACEMENT OF SELF-LEVELING SILICONE JOINT SEALANT.

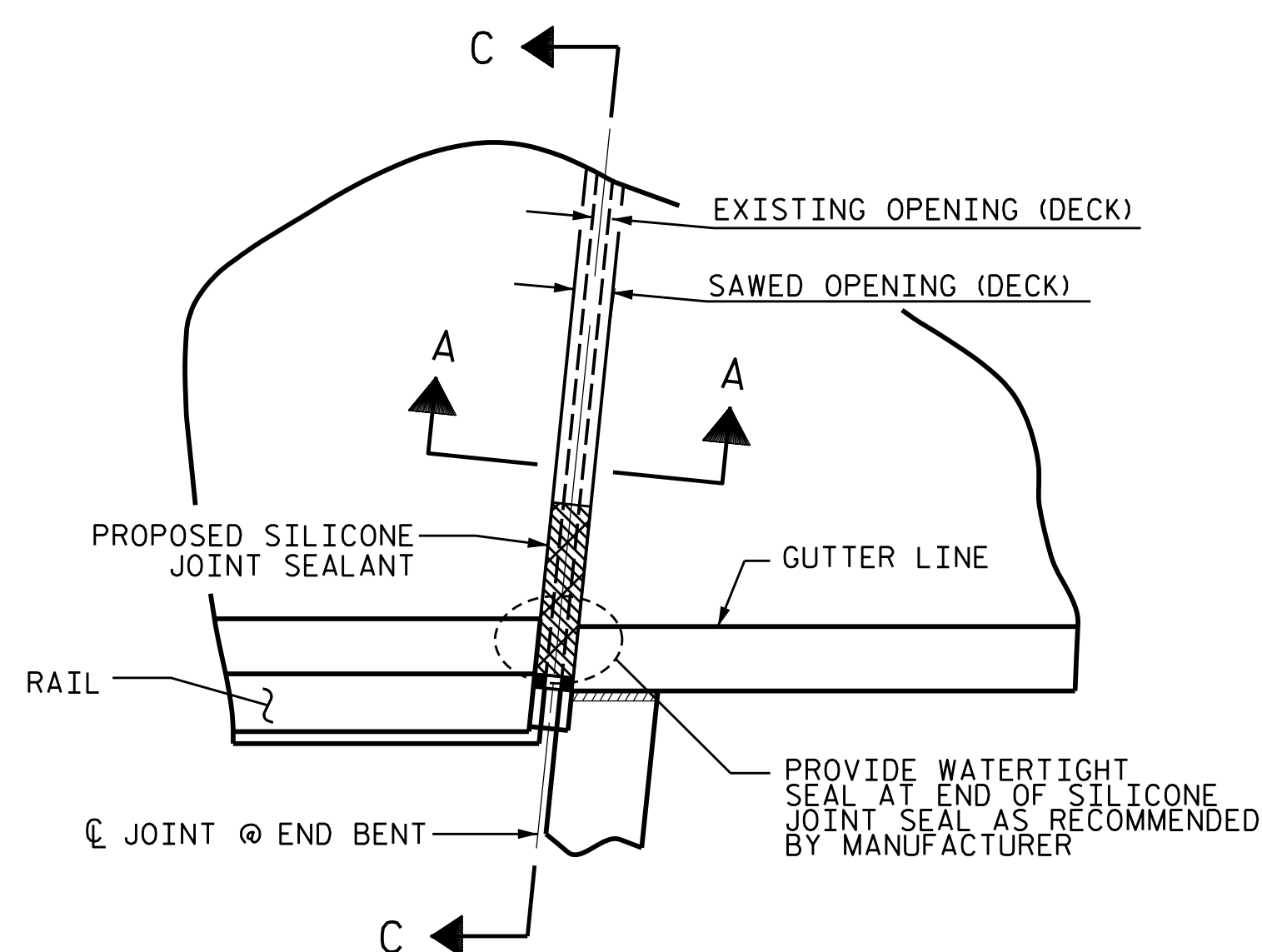

PLAN

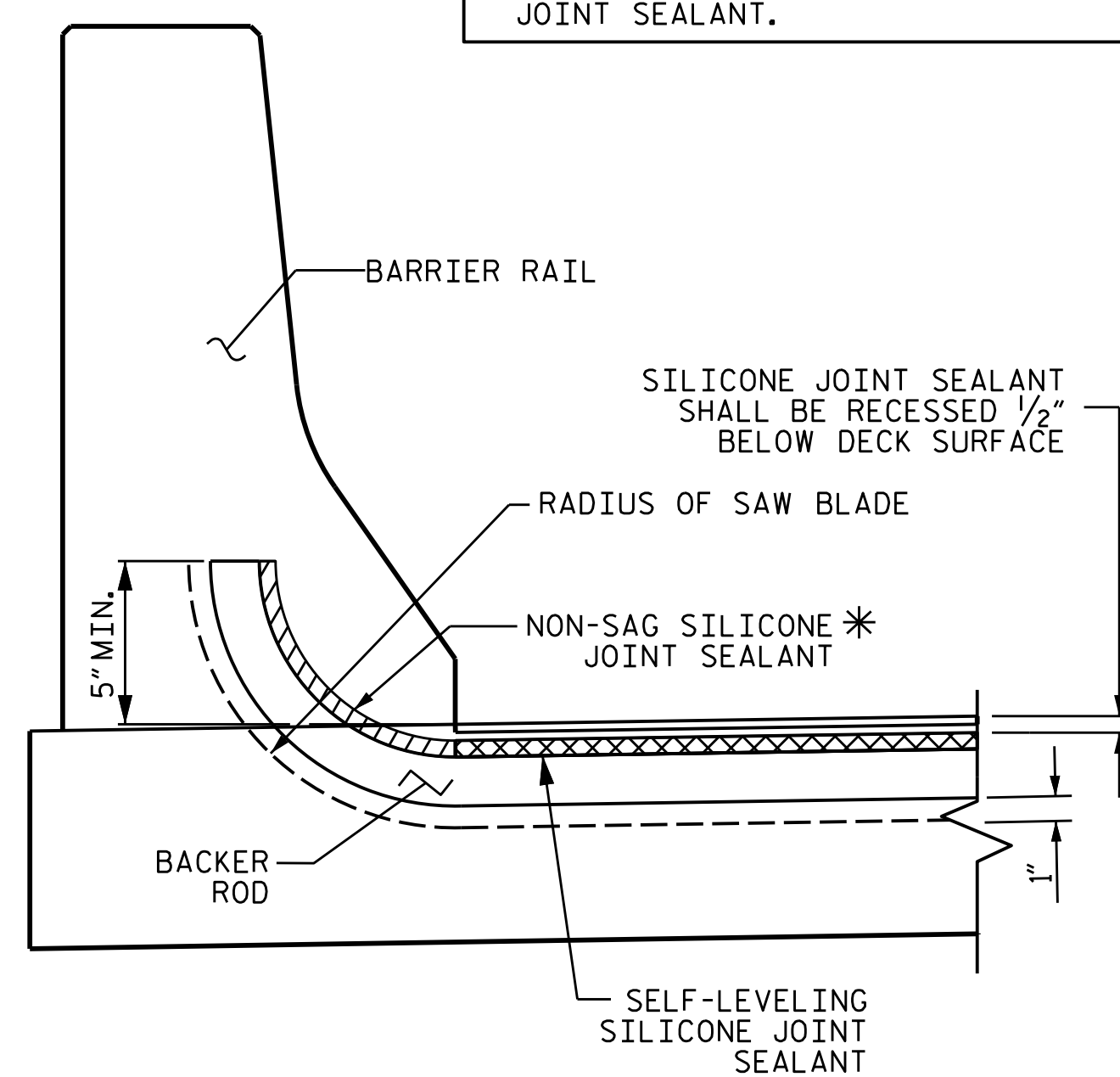

SECTION C-C

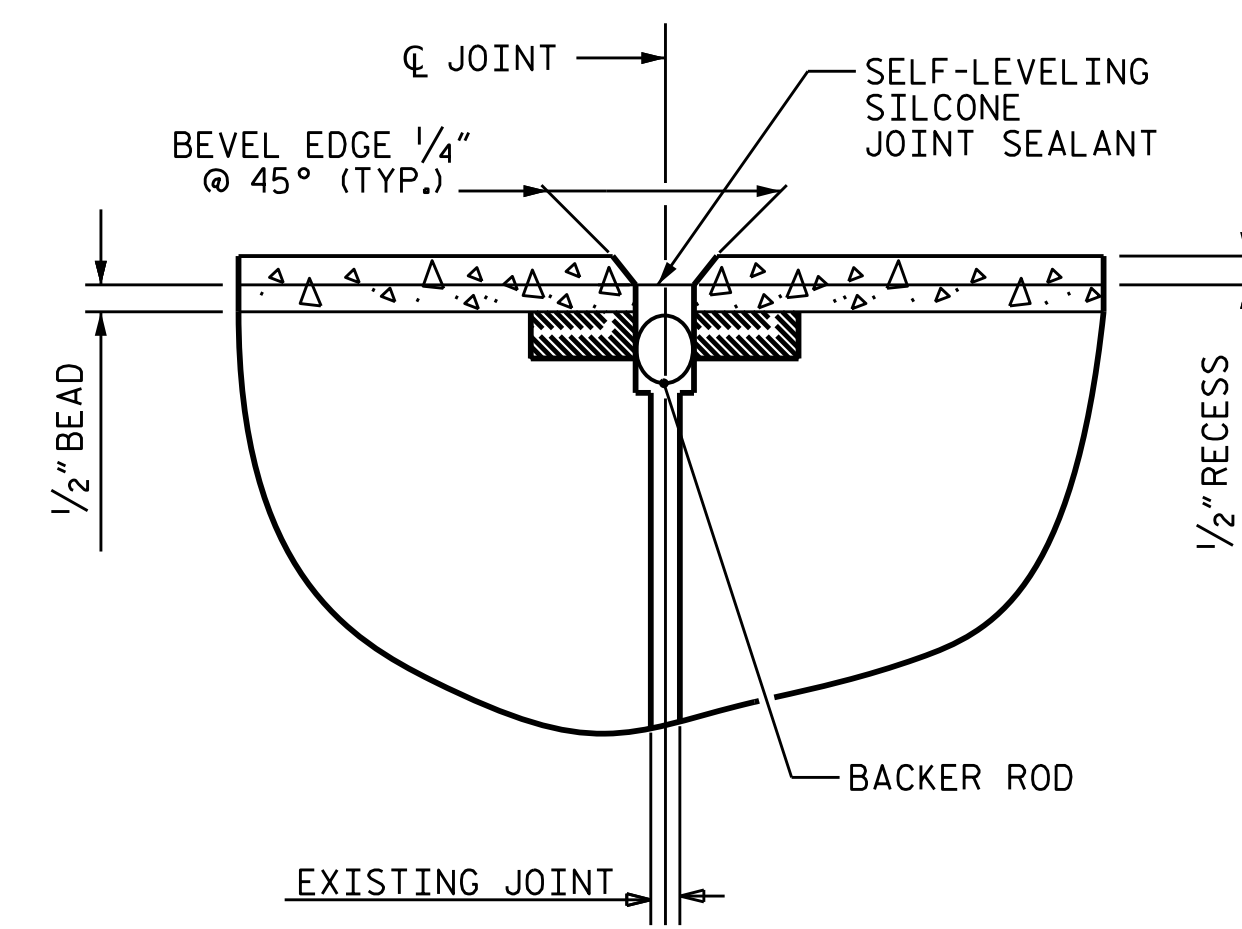

DETAIL A

JOINT REPAIR QUANTITY TABLE		
	ESTIMATE	ACTUAL
POURABLE SILICONE JOINT SEALANT		
END BENT 1	59.5 LF	
END BENT 2	59.3 LF	
TOTAL	118.8 LF	

PROJECT NO. I-5950  
DAVIDSON COUNTY  
 BRIDGE NO. 280147

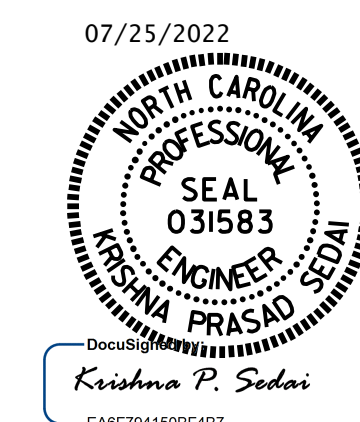

STATE OF NORTH CAROLINA  
 DEPARTMENT OF TRANSPORTATION  
 RALEIGH

**JOINT REPAIR DETAILS**

DRAWN BY: M. G. SHAIKH DATE: 10/2020  
 CHECKED BY: E. BAYISSA DATE: 03/2022

REVISIONS						SHEET NO.
NO.	BY:	DATE:	NO.	BY:	DATE:	
1			3			S4-05
2			4			TOTAL SHEETS 14

DOCUMENT NOT CONSIDERED FINAL UNLESS ALL SIGNATURES COMPLETED

### AS-BUILT REPAIR QUANTITY TABLE

DECK UNDERSIDE REPAIRS SPAN A	QUANTITIES			
	ESTIMATE		ACTUAL	
SHOTCRETE REPAIRS	AREA SF	VOLUME CF	AREA SF	VOLUME CF
UNDERSIDE OF DECK	0.0	0.0		
CONCRETE DIAPHRAGM	0.0	0.0		
OVERHANG	0.0	0.0		
<b>CONCRETE REPAIRS</b>	<b>AREA SF</b>	<b>VOLUME CF</b>	<b>AREA SF</b>	<b>VOLUME CF</b>
UNDERSIDE OF DECK	0.0	0.0		
CONCRETE DIAPHRAGM	0.0	0.0		
OVERHANG	0.0	0.0		
<b>EPOXY RESIN INJECTION</b>		<b>LIN. FT.</b>		<b>LIN. FT.</b>
UNDERSIDE OF DECK		0.0		
CONCRETE DIAPHRAGM		0.0		
OVERHANG		0.0		

VALUES IN CHART REPRESENT ESTIMATED REPAIR TOTALS AFTER REMOVAL OF UNSOUND CONCRETE, MIN. OF 2" BEHIND REBAR AND MIN. 2" CLEAR TO SAWCUT. SEE REPAIR DETAILS.

#### NOTES

REPAIR LOCATIONS AND ESTIMATE OF QUANTITIES ARE GIVEN BASED ON THE BEST INFORMATION AVAILABLE. IF ADDITIONAL REPAIRS NOT SHOWN ON THE DRAWINGS ARE DEEMED NECESSARY BY THE ENGINEER, THE ENGINEER SHALL NOTE ON THE DRAWINGS THE APPROXIMATE LOCATION AND DESCRIPTION OF THE REPAIRS AND ENTER THE ACTUAL QUANTITIES INTO THE AS-BUILT REPAIR QUANTITY TABLE.

CONTRACTOR SHALL SAW CUT TO A NOMINAL DEPTH OF 1/2" BUT REINFORCING STEEL SHALL NOT BE DAMAGED.

CONTRACTOR SHALL REMOVE SURFACE CONCRETE TO VERIFY THAT SAWCUT DEPTH WILL NOT DAMAGE EXISTING REINFORCING STEEL.

SHOTCRETE REPAIRS MAYBE SUBSTITUTED IN LIEU OF CONCRETE REPAIRS WITH THE APPROVAL OF THE ENGINEER.

FOR UNDERSIDE OF DECK REPAIRS, SEE "OVERHANG, DIAPHRAGM AND BRIDGE RAIL REPAIR DETAILS" SHEET.



FOR SHOTCRETE REPAIRS, SEE SPECIAL PROVISIONS.

FOR CONCRETE REPAIRS, SEE SPECIAL PROVISIONS.

FOR EPOXY RESIN INJECTION, SEE SPECIAL PROVISIONS.

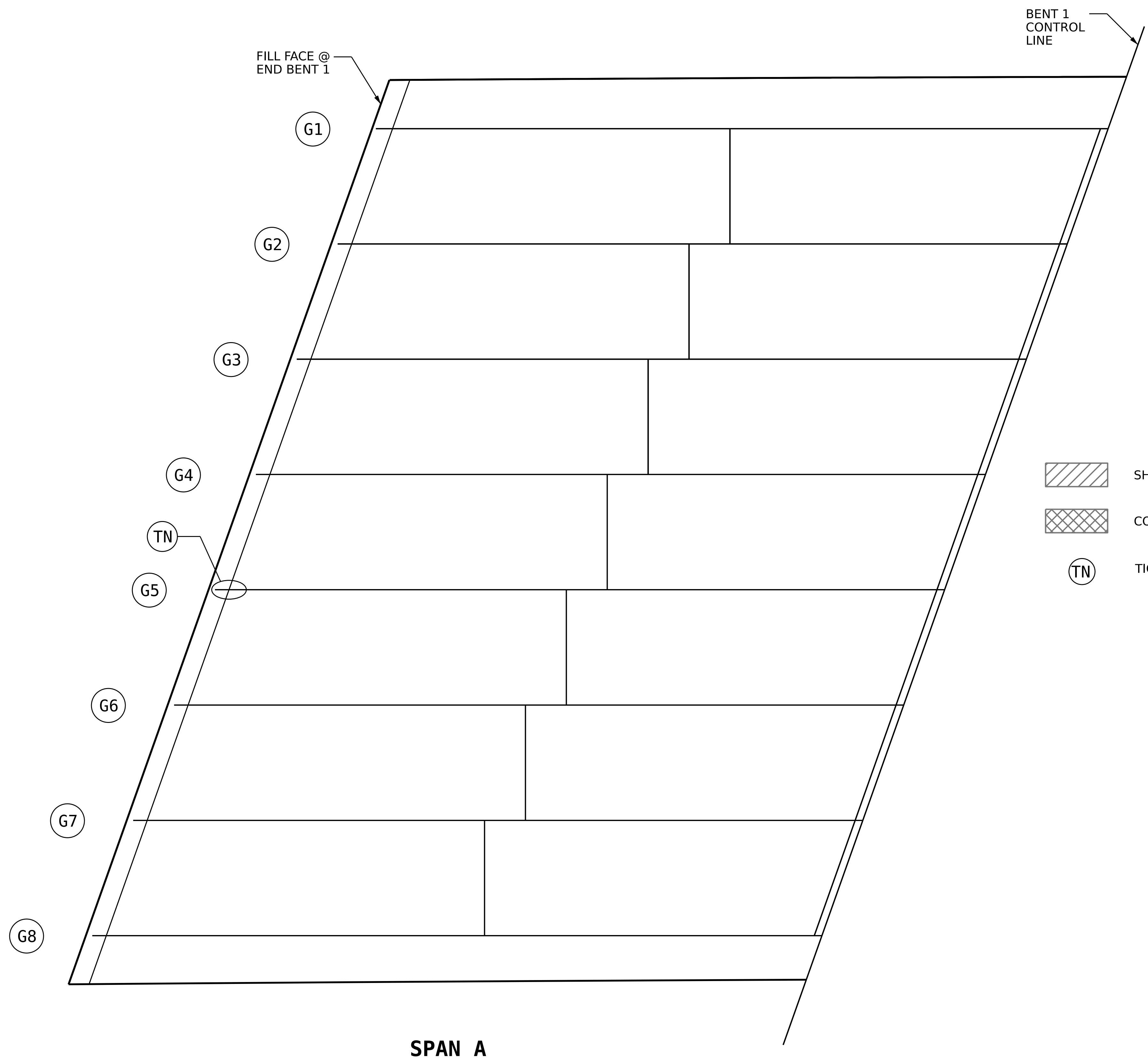
PRIOR TO CLEANING AND PAINTING, REPLACE AND /OR TIGHTEN ANCHOR BOLT NUTS. SEE SPECIAL PROVISIONS.

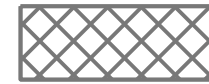

-  SHOTCRETE REPAIR AREA
-  CONCRETE REPAIR AREA
-  TIGHTEN ANCHOR BOLT NUT

PROJECT NO. I-5950  
DAVIDSON COUNTY  
 BRIDGE NO. 280147

SHEET 1 OF 3

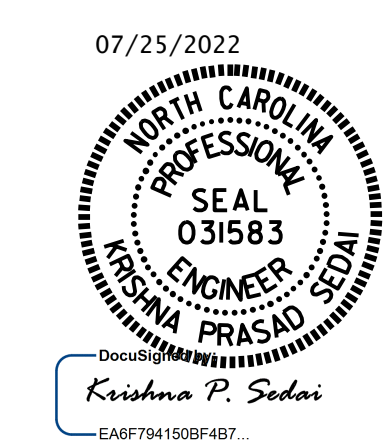

STATE OF NORTH CAROLINA  
 DEPARTMENT OF TRANSPORTATION  
 RALEIGH

### DECK UNDERSIDE REPAIR SPAN A

REVISIONS						SHEET NO.
NO.	BY:	DATE:	NO.	BY:	DATE:	S4-06
1			3			TOTAL SHEETS
2			4			14

DOCUMENT NOT CONSIDERED FINAL UNLESS ALL SIGNATURES COMPLETED

DRAWN BY : M. G. SHAIKH DATE : 09/2021  
 CHECKED BY : E. BAYISSA DATE : 03/2022

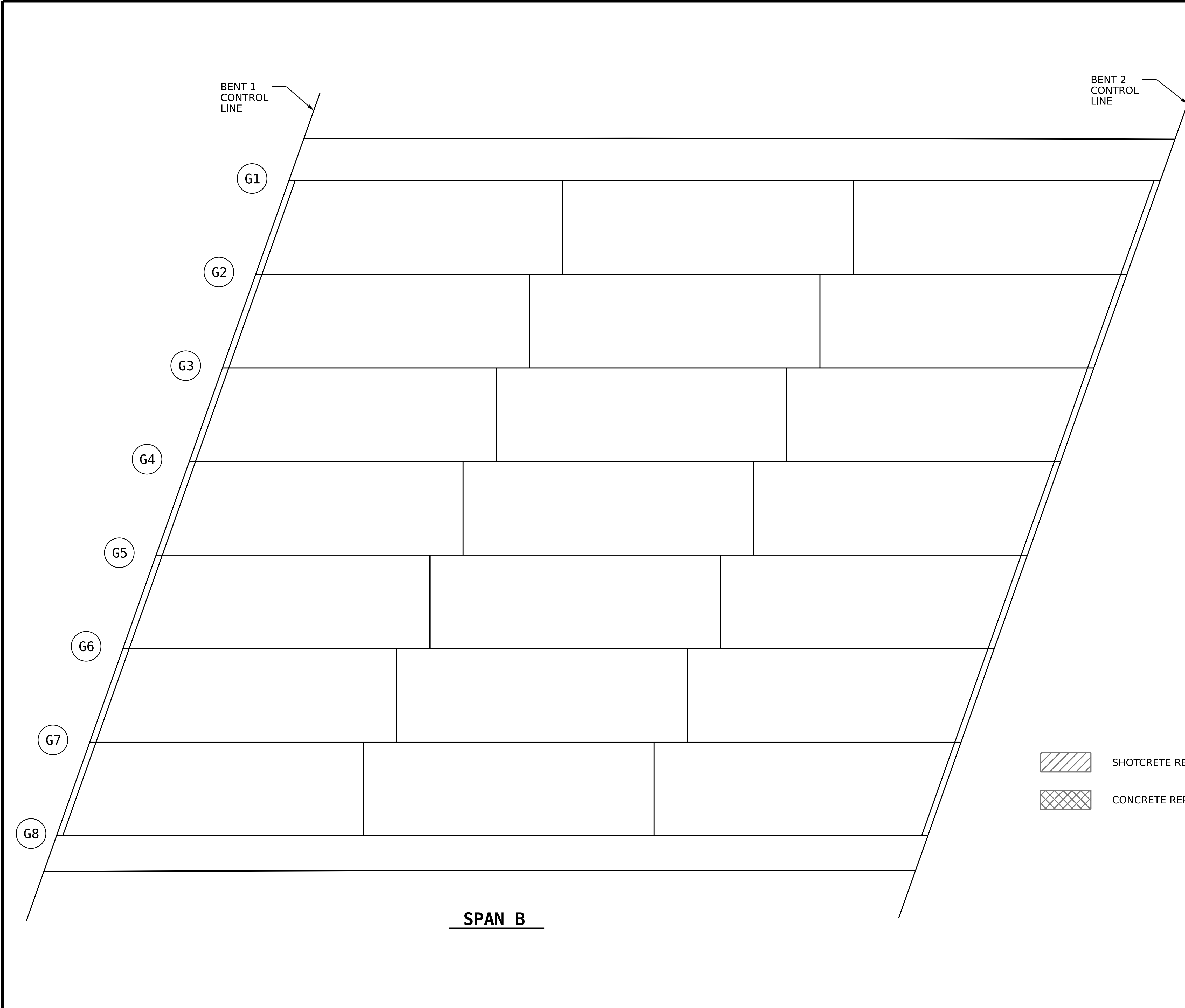

**AS-BUILT REPAIR QUANTITY TABLE**

DECK UNDERSIDE REPAIRS SPAN B	QUANTITIES			
	ESTIMATE		ACTUAL	
SHOTCRETE REPAIRS	AREA SF	VOLUME CF	AREA SF	VOLUME CF
UNDERSIDE OF DECK	0.0	0.0		
CONCRETE DIAPHRAGM	0.0	0.0		
OVERHANG	0.0	0.0		
<b>CONCRETE REPAIRS</b>	<b>AREA SF</b>	<b>VOLUME CF</b>	<b>AREA SF</b>	<b>VOLUME CF</b>
UNDERSIDE OF DECK	0.0	0.0		
CONCRETE DIAPHRAGM	0.0	0.0		
OVERHANG	0.0	0.0		
<b>EPOXY RESIN INJECTION</b>		<b>LIN. FT.</b>		<b>LIN. FT.</b>
UNDERSIDE OF DECK		0.0		
CONCRETE DIAPHRAGM		0.0		
OVERHANG		0.0		

VALUES IN CHART REPRESENT ESTIMATED REPAIR TOTALS AFTER REMOVAL OF UNSOUND CONCRETE, MIN. OF 1" BEHIND REBAR AND MIN. 2" CLEAR TO SAWCUT. SEE REPAIR DETAILS.

**NOTES**

REPAIR LOCATIONS AND ESTIMATE OF QUANTITIES ARE GIVEN BASED ON THE BEST INFORMATION AVAILABLE. IF ADDITIONAL REPAIRS NOT SHOWN ON THE DRAWINGS ARE DEEMED NECESSARY BY THE ENGINEER, THE ENGINEER SHALL NOTE ON THE DRAWINGS THE APPROXIMATE LOCATION AND DESCRIPTION OF THE REPAIRS AND ENTER THE ACTUAL QUANTITIES INTO THE AS-BUILT REPAIR QUANTITY TABLE.

CONTRACTOR SHALL SAW CUT TO A NOMINAL DEPTH OF 1/2" BUT REINFORCING STEEL SHALL NOT BE DAMAGED.

CONTRACTOR SHALL REMOVE SURFACE CONCRETE TO VERIFY THAT SAWCUT DEPTH WILL NOT DAMAGE EXISTING REINFORCING STEEL.

SHOTCRETE REPAIRS MAYBE SUBSTITUTED IN LIEU OF CONCRETE REPAIRS WITH THE APPROVAL OF THE ENGINEER.

FOR UNDERSIDE OF DECK REPAIRS, SEE "OVERHANG, DIAPHRAGM AND BRIDGE RAIL REPAIR DETAILS" SHEET.

FOR SHOTCRETE REPAIRS, SEE SPECIAL PROVISIONS.

FOR CONCRETE REPAIRS, SEE SPECIAL PROVISIONS.

FOR EPOXY RESIN INJECTION, SEE SPECIAL PROVISIONS.

 SHOTCRETE REPAIR AREA

 CONCRETE REPAIR AREA

PROJECT NO. I-5950  
DAVIDSON COUNTY  
 BRIDGE NO. 280147

SHEET 2 OF 3

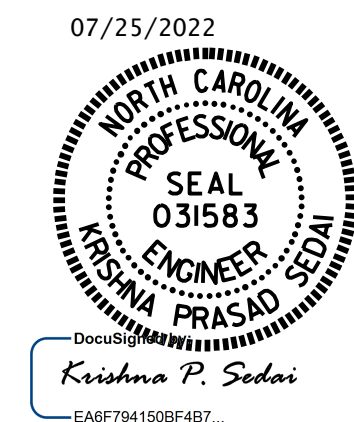

STATE OF NORTH CAROLINA  
 DEPARTMENT OF TRANSPORTATION  
 RALEIGH  
**DECK UNDERSIDE REPAIR  
 SPAN B**

DRAWN BY : M. G. SHAIKH DATE : 09/2021  
 CHECKED BY : E. BAYISSA DATE : 03/2022

DOCUMENT NOT CONSIDERED  
 FINAL UNLESS ALL  
 SIGNATURES COMPLETED

REVISIONS						SHEET NO.
NO.	BY:	DATE:	NO.	BY:	DATE:	S4-07
1			3			TOTAL SHEETS
2			4			14

### AS-BUILT REPAIR QUANTITY TABLE

DECK UNDERSIDE REPAIRS SPAN C	QUANTITIES			
	ESTIMATE		ACTUAL	
SHOTCRETE REPAIRS	AREA SF	VOLUME CF	AREA SF	VOLUME CF
UNDERSIDE OF DECK	0.0	0.0		
CONCRETE DIAPHRAGM	0.0	0.0		
OVERHANG	0.0	0.0		
CONCRETE REPAIRS	AREA SF	VOLUME CF	AREA SF	VOLUME CF
UNDERSIDE OF DECK	0.0	0.0		
CONCRETE DIAPHRAGM	0.0	0.0		
OVERHANG	0.0	0.0		
EPOXY RESIN INJECTION		LIN. FT.		LIN. FT.
UNDERSIDE OF DECK		0.0		
CONCRETE DIAPHRAGM		0.0		
OVERHANG		0.0		

VALUES IN CHART REPRESENT ESTIMATED REPAIR TOTALS AFTER REMOVAL OF UNSOUND CONCRETE, MIN. OF 1" BEHIND REBAR AND MIN. 2" CLEAR TO SAWCUT. SEE REPAIR DETAILS.

#### NOTES

REPAIR LOCATIONS AND ESTIMATE OF QUANTITIES ARE GIVEN BASED ON THE BEST INFORMATION AVAILABLE. IF ADDITIONAL REPAIRS NOT SHOWN ON THE DRAWINGS ARE DEEMED NECESSARY BY THE ENGINEER, THE ENGINEER SHALL NOTE ON THE DRAWINGS THE APPROXIMATE LOCATION AND DESCRIPTION OF THE REPAIRS AND ENTER THE ACTUAL QUANTITIES INTO THE AS-BUILT REPAIR QUANTITY TABLE.

CONTRACTOR SHALL SAW CUT TO A NOMINAL DEPTH OF 1/2" BUT REINFORCING STEEL SHALL NOT BE DAMAGED.

CONTRACTOR SHALL REMOVE SURFACE CONCRETE TO VERIFY THAT SAWCUT DEPTH WILL NOT DAMAGE EXISTING REINFORCING STEEL.

SHOTCRETE REPAIRS MAYBE SUBSTITUTED IN LIEU OF CONCRETE REPAIRS WITH THE APPROVAL OF THE ENGINEER.



FOR UNDERSIDE OF DECK REPAIRS, SEE "OVERHANG, DIAPHRAGM AND BRIDGE RAIL REPAIR DETAILS" SHEET.

FOR SHOTCRETE REPAIRS, SEE SPECIAL PROVISIONS.

FOR CONCRETE REPAIRS, SEE SPECIAL PROVISIONS.

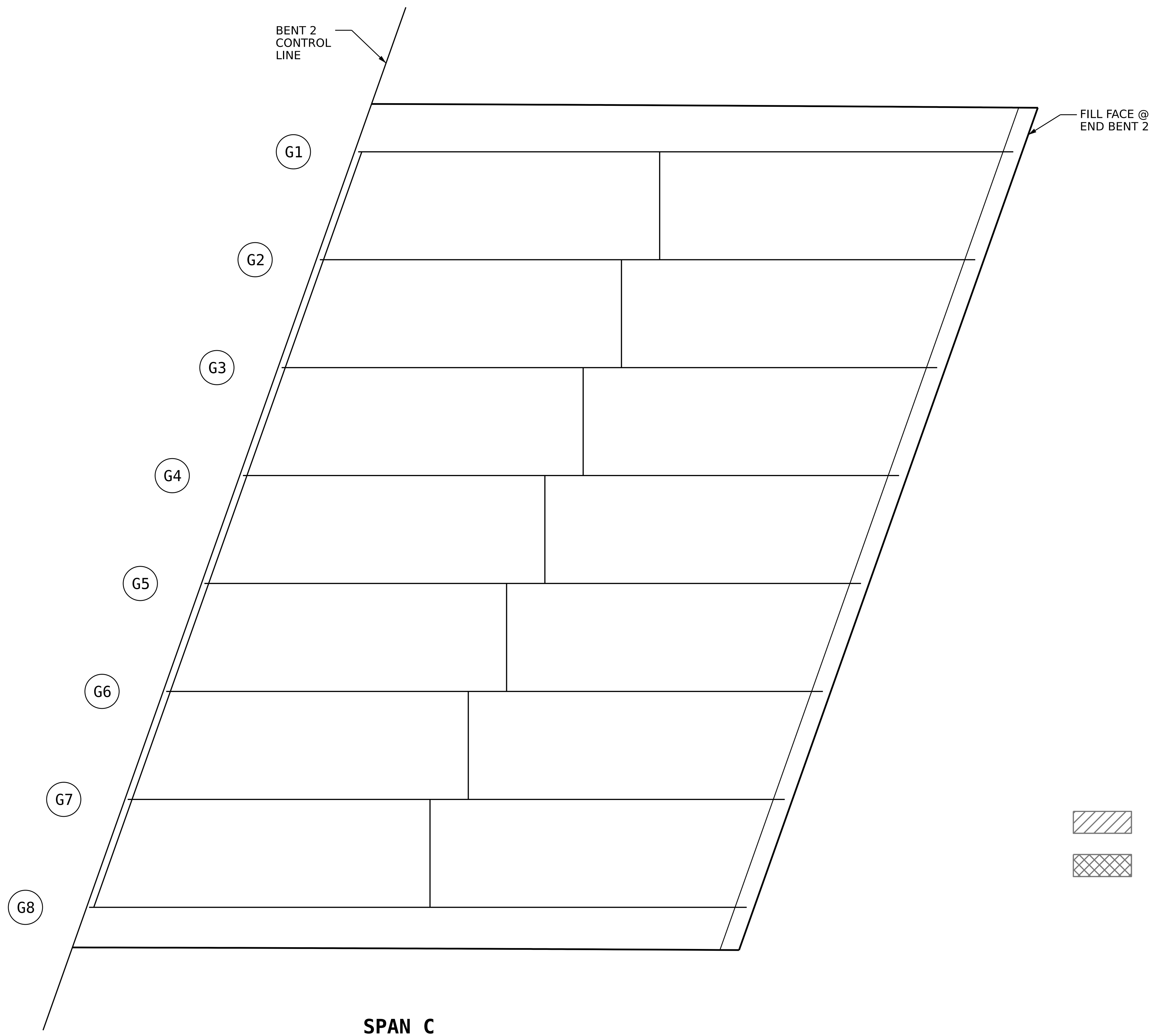
FOR EPOXY RESIN INJECTION, SEE SPECIAL PROVISIONS.



 SHOTCRETE REPAIR AREA  
 CONCRETE REPAIR AREA

PROJECT NO. **I-5950**  
**DAVIDSON** COUNTY  
 BRIDGE NO. **280147**

SHEET 3 OF 3

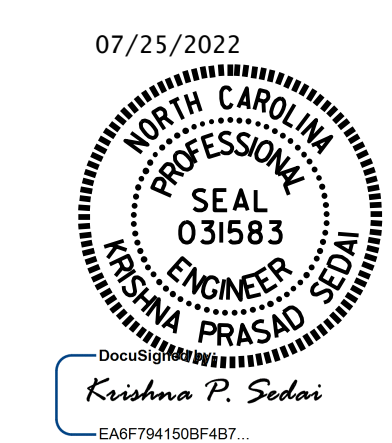

STATE OF NORTH CAROLINA  
 DEPARTMENT OF TRANSPORTATION  
 RALEIGH

### DECK UNDERSIDE REPAIR SPAN C

REVISIONS						SHEET NO.
NO.	BY:	DATE:	NO.	BY:	DATE:	S4-08
1			3			TOTAL SHEETS
2			4			14

DOCUMENT NOT CONSIDERED FINAL UNLESS ALL SIGNATURES COMPLETED

DRAWN BY : M. G. SHAIKH DATE : 09/2021  
 CHECKED BY : E. BAYISSA DATE : 03/2022

### AS-BUILT REPAIR QUANTITY TABLE

REPAIRS - END BENT 1	QUANTITIES			
	ESTIMATE		ACTUAL	
SHOTCRETE REPAIRS	AREA SF	VOLUME CF	AREA SF	VOLUME CF
CAP	0.3	0.2		
CURTAIN WALL	0.5	0.3		
WINGWALL				
CONCRETE REPAIRS	AREA SF	VOLUME CF	AREA SF	VOLUME CF
CAP	0	0		
CURTAIN WALL	0	0		
WINGWALL				
EPOXY RESIN INJECTION		LINEAR FT		LINEAR FT
CAP		0		
CURTAIN WALL		19.5		
WINGWALL				
EPOXY COATING		AREA SF		AREA SF
CAP		98.3		
CURTAIN WALL		249.7		

VALUES IN CHART REPRESENT ESTIMATED REPAIR TOTALS AFTER REMOVAL OF UNSOUND CONCRETE, MIN. OF 1" BEHIND REBAR AND MIN. 2" CLEAR TO SAWCUT. SEE REPAIR DETAILS.

#### NOTES

REPAIR LOCATIONS AND ESTIMATE OF QUANTITIES ARE GIVEN BASED ON THE BEST INFORMATION AVAILABLE. IF ADDITIONAL REPAIRS NOT SHOWN ON THE DRAWINGS ARE DEEMED NECESSARY BY THE ENGINEER, THE ENGINEER SHALL NOTE ON THE DRAWINGS THE APPROXIMATE LOCATION AND DESCRIPTION OF THE REPAIRS AND ENTER THE ACTUAL QUANTITIES INTO THE AS-BUILT REPAIR QUANTITY TABLE.

CLEAN AND REMOVE DEBRIS FROM THE TOP OF THE CAP AND APPLY EPOXY PROTECTIVE COATING. EPOXY COATING SHALL BE APPLIED TO THE TOP SURFACE OF THE CAP. THE CONTRACTOR SHALL NOT COAT THE AREA OF THE CAP BENEATH THE MASONRY PLATES. FOR EPOXY COATING, SEE SPECIAL PROVISIONS.

SHOTCRETE REPAIRS MAYBE SUBSTITUTED IN LIEU OF CONCRETE REPAIRS WITH THE APPROVAL OF THE ENGINEER.

FOR CAP AND COLUMN REPAIRS, SEE "TYPICAL CAP AND COLUMN REPAIR DETAILS" SHEET.

FOR SHOTCRETE REPAIRS, SEE SPECIAL PROVISIONS.

FOR CONCRETE REPAIRS, SEE SPECIAL PROVISIONS.

FOR EPOXY RESIN INJECTION, SEE SPECIAL PROVISIONS.

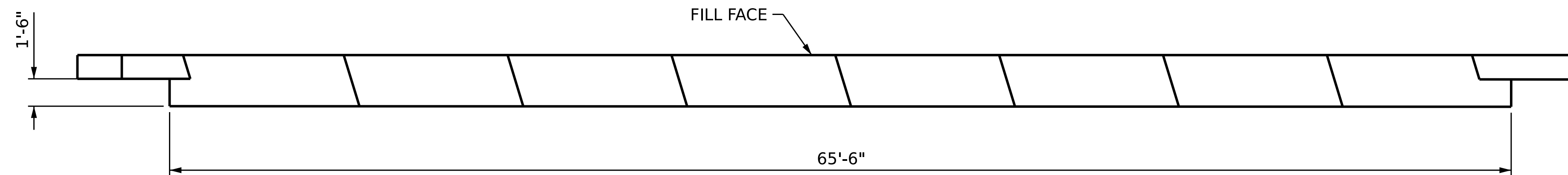

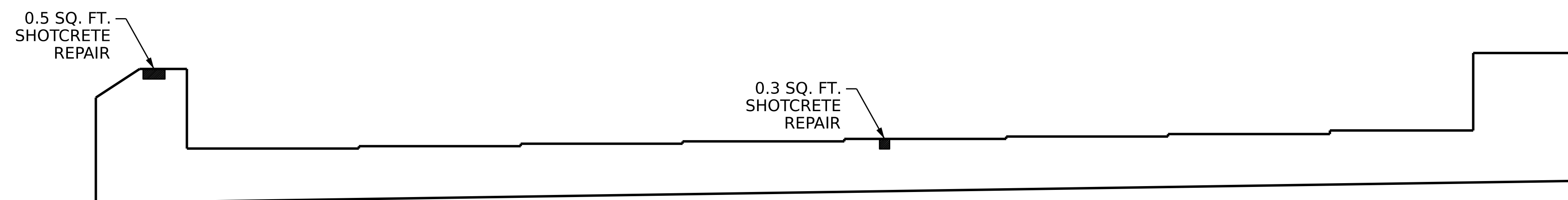

PLAN

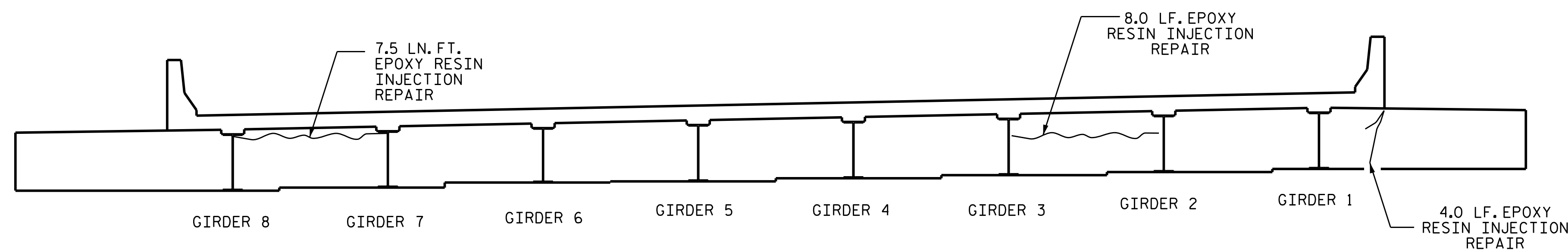

ELEVATION



TYPICAL SECTION

-  SHOTCRETE REPAIR AREA
-  CONCRETE REPAIR AREA
-  EPOXY RESIN INJECTION

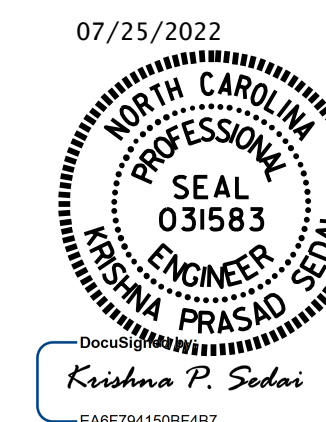

PROJECT NO. **I-5950**  
**DAVIDSON** COUNTY  
 BRIDGE NO. **280147**

STATE OF NORTH CAROLINA  
 DEPARTMENT OF TRANSPORTATION  
 RALEIGH

### SUBSTRUCTURE REPAIR END BENT 1

REVISIONS						SHEET NO. S4-09
NO.	BY:	DATE:	NO.	BY:	DATE:	
1			3			TOTAL SHEETS 14
2			4			

DOCUMENT NOT CONSIDERED  
 FINAL UNLESS ALL  
 SIGNATURES COMPLETED

DRAWN BY : M. G. SHAIKH DATE : 09/2020  
 CHECKED BY : A. SORSENGINH DATE : 09/2022



AS-BUILT REPAIR QUANTITY TABLE				
BENT 1 SPAN A FACE	QUANTITIES			
	ESTIMATE		ACTUAL	
SHOTCRETE REPAIRS	AREA SQ. FT.	VOLUME CU. FT.	AREA SQ. FT.	VOLUME CU. FT.
CAP	0.0	0.0		
COLUMN	0.0	0.0		
CONCRETE REPAIRS	AREA SQ. FT.	VOLUME CU. FT.	AREA SQ. FT.	VOLUME CU. FT.
CAP	0.0	0.0		
COLUMN	0.0	0.0		
EPOXY RESIN INJECTION	LIN. FT.		LIN. FT.	
CAP	0.0			
COLUMN	0.0			
EPOXY COATING	SQ. FT.		SQ. FT.	
TOP OF BENT CAP	187.6			
TOP OF STRUT	111.4			

VALUES IN CHART REPRESENT ESTIMATED REPAIR TOTALS AFTER REMOVAL OF UNSOUND CONCRETE, MINIMUM OF 1" BEHIND REBAR AND MINIMUM OF 2" CLEARANCE TO SAWCUT.

**NOTES:**  
 REPAIR LOCATIONS AND ESTIMATE OF QUANTITIES ARE BASED ON THE BEST INFORMATION AVAILABLE. IF ADDITIONAL REPAIRS NOT SHOWN ON THE DRAWINGS ARE DEEMED NECESSARY BY THE ENGINEER, THE ENGINEER WILL NOTE ON THE DRAWINGS THE APPROXIMATE LOCATIONS AND DESCRIPTION OF THE REPAIRS AND ENTER THE ACTUAL QUANTITIES INTO THE AS-BUILT REPAIR QUANTITY TABLE.  
 CLEAN AND REMOVE DEBRIS FROM THE TOP OF THE CAP AND APPLY EPOXY PROTECTIVE COATING. EPOXY COATING SHALL BE APPLIED TO THE TOP SURFACE OF THE CAP. THE CONTRACTOR SHALL NOT COAT THE AREA OF THE CAP BENEATH THE MASONRY PLATES. FOR EPOXY COATING, SEE SPECIAL PROVISIONS.  
 SHOTCRETE REPAIRS MAY BE REPLACED WITH CONCRETE REPAIRS WITH THE APPROVAL OF THE ENGINEER.  
 FOR CAP AND COLUMN REPAIR DETAILS, SEE "TYPICAL CAP AND COLUMN REPAIR DETAILS" SHEET.  
 FOR SHOTCRETE REPAIRS, SEE SPECIAL PROVISIONS.  
 FOR CONCRETE REPAIRS, SEE SPECIAL PROVISIONS.  
 FOR EPOXY RESIN INJECTION, SEE SPECIAL PROVISIONS.

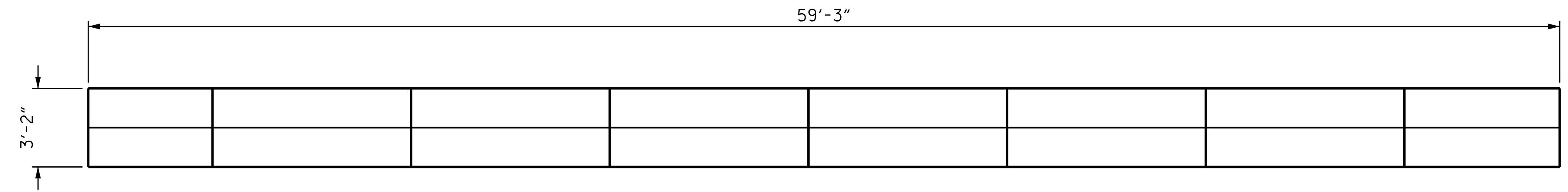

**PLAN - TOP OF CAP**

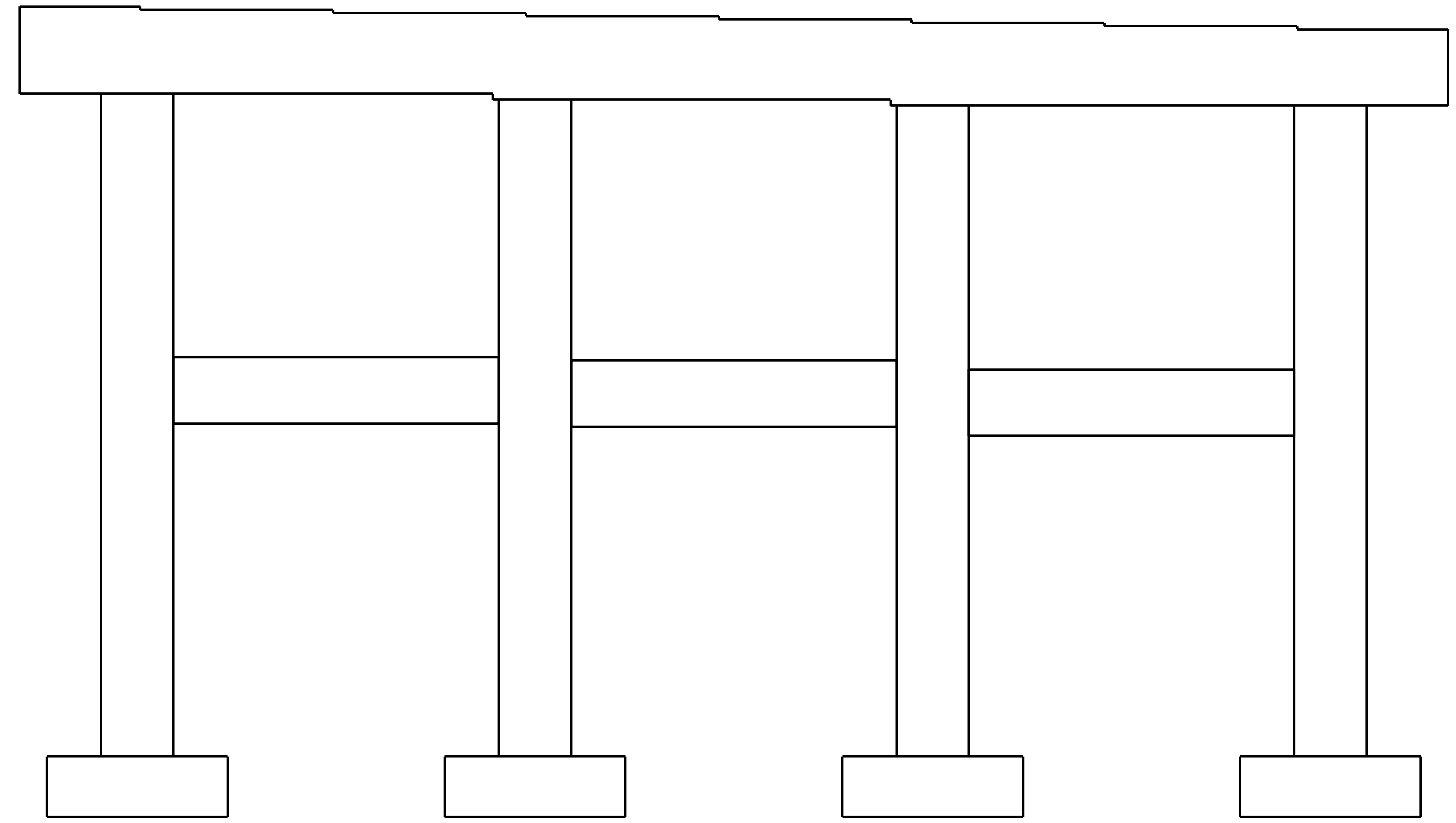

SPAN B  
SPAN A

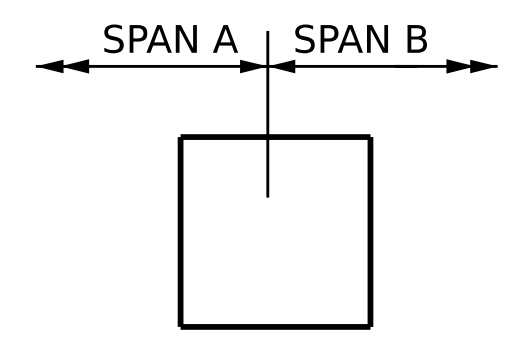

**ELEVATION**

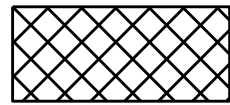
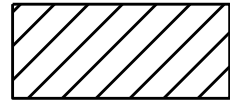

**END VIEW**

-  CONCRETE REPAIR AREA
-  SHOTCRETE REPAIR AREA
-  EPOXY RESIN INJECTION (ERI)

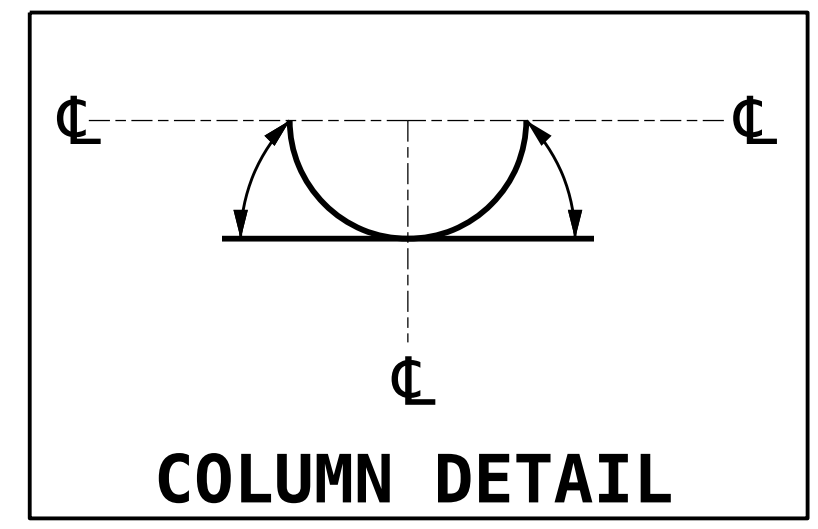

PROJECT NO. **I-5950**  
**DAVIDSON** COUNTY  
 BRIDGE NO. **280147**  
 SHEET 1 OF 2

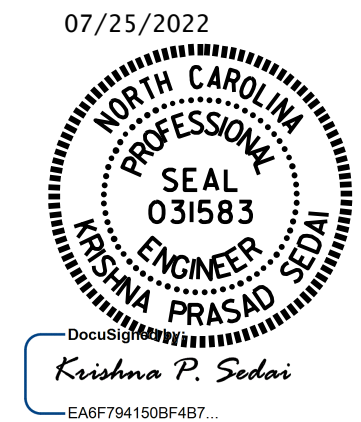

STATE OF NORTH CAROLINA  
 DEPARTMENT OF TRANSPORTATION  
 RALEIGH  
**SUBSTRUCTURE REPAIR  
 BENT 1  
 SPAN A FACE**

REVISIONS						SHEET NO.
NO.	BY:	DATE:	NO.	BY:	DATE:	S4-10
1			3			TOTAL SHEETS
2			4			14

DOCUMENT NOT CONSIDERED FINAL UNLESS ALL SIGNATURES COMPLETED

DRAWN BY : M. G. SHAIKH DATE : 09/2021  
 CHECKED BY : E. BAYISSA DATE : 03/2022

AS-BUILT REPAIR QUANTITY TABLE				
BENT 1 SPAN B FACE	QUANTITIES			
	ESTIMATE		ACTUAL	
SHOTCRETE REPAIRS	AREA SQ. FT.	VOLUME CU. FT.	AREA SQ. FT.	VOLUME CU. FT.
CAP	0.0	0.0		
COLUMN	0.0	0.0		
CONCRETE REPAIRS	AREA SQ. FT.	VOLUME CU. FT.	AREA SQ. FT.	VOLUME CU. FT.
CAP	0.0	0.0		
COLUMN	0.0	0.0		
EPOXY RESIN INJECTION		LIN. FT.		LIN. FT.
CAP		0.0		
COLUMN		0.0		

VALUES IN CHART REPRESENT ESTIMATED REPAIR TOTALS AFTER REMOVAL OF UNSOUND CONCRETE, MINIMUM OF 1" BEHIND REBAR AND MINIMUM OF 2" CLEARANCE TO SAWCUT.

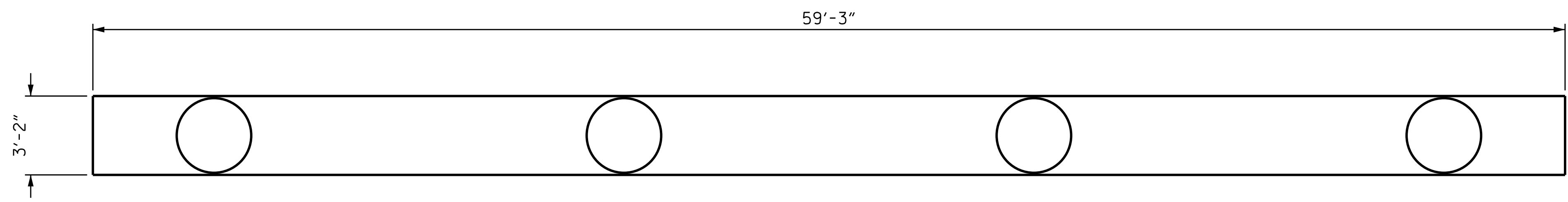

**PLAN - BOTTOM OF CAP**

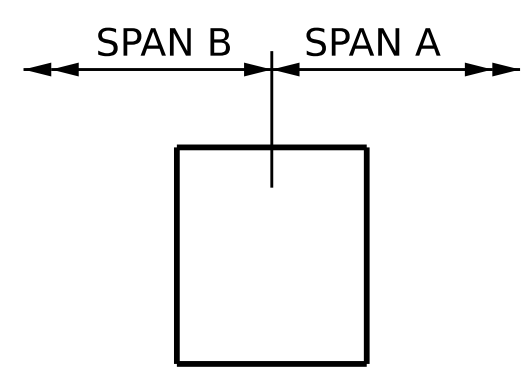

**END VIEW**

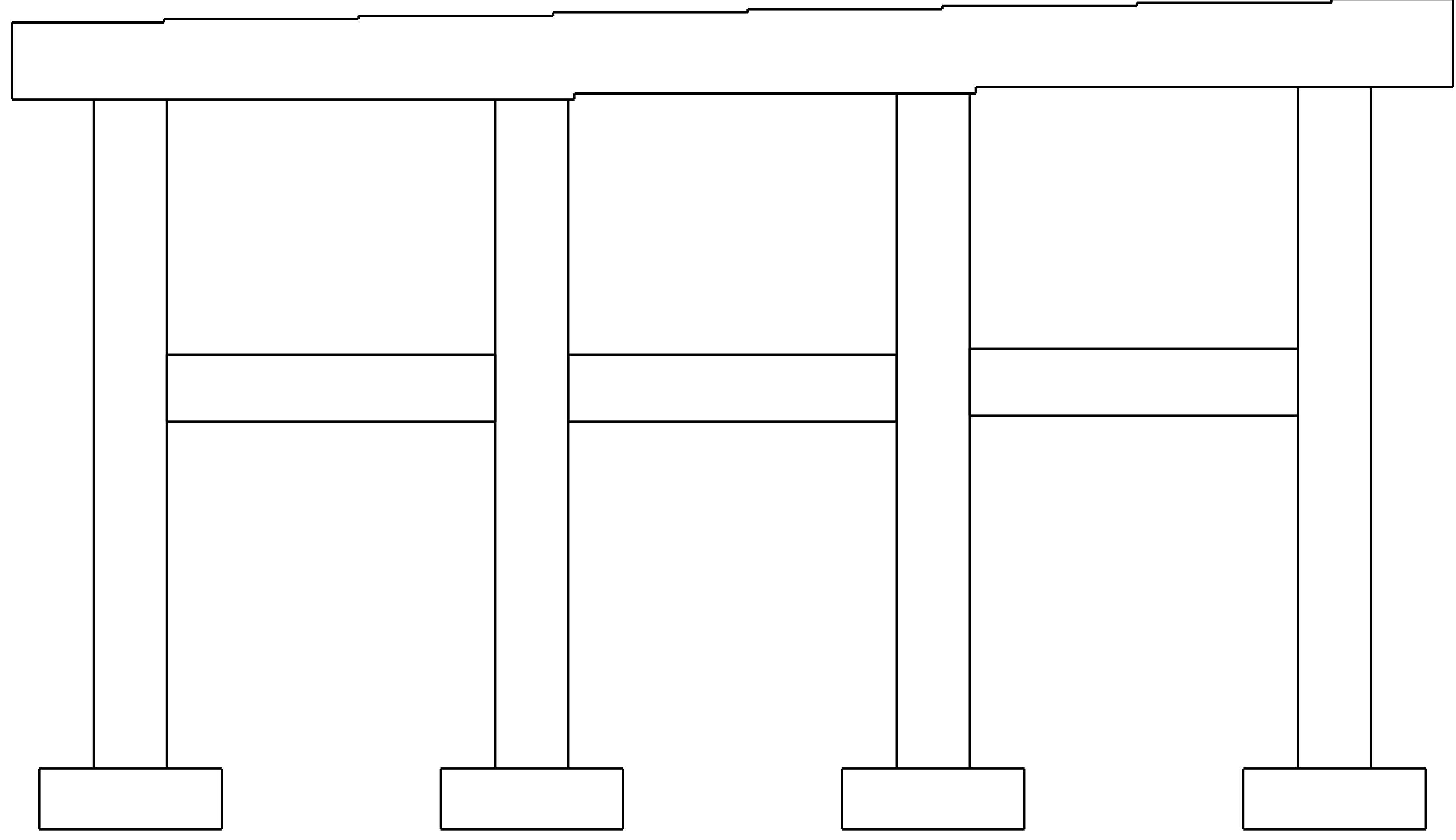

**ELEVATION**

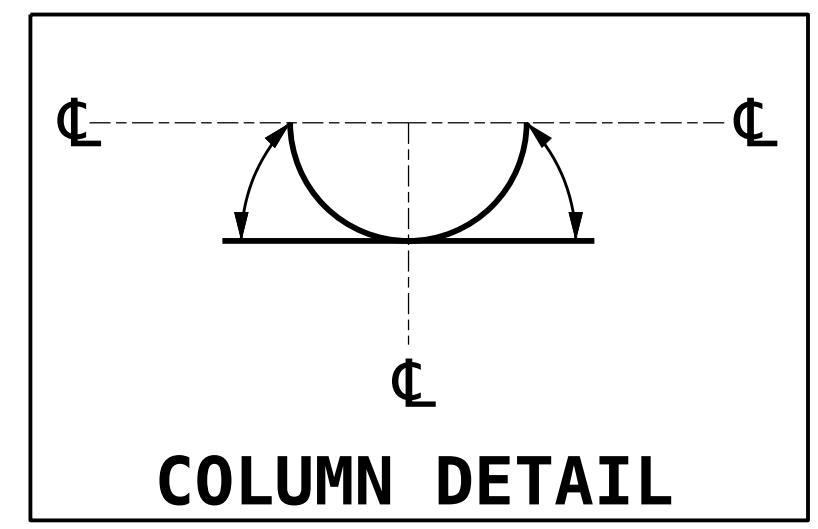

**COLUMN DETAIL**

- CONCRETE REPAIR AREA
- SHOTCRETE REPAIR AREA
- EPOXY RESIN INJECTION (ERI)

**NOTES:**  
 REPAIR LOCATIONS AND ESTIMATE OF QUANTITIES ARE BASED ON THE BEST INFORMATION AVAILABLE. IF ADDITIONAL REPAIRS NOT SHOWN ON THE DRAWINGS ARE DEEMED NECESSARY BY THE ENGINEER, THE ENGINEER WILL NOTE ON THE DRAWINGS THE APPROXIMATE LOCATIONS AND DESCRIPTION OF THE REPAIRS AND ENTER THE ACTUAL QUANTITIES INTO THE AS-BUILT REPAIR QUANTITY TABLE.

SHOTCRETE REPAIRS MAY BE REPLACED WITH CONCRETE REPAIRS WITH THE APPROVAL OF THE ENGINEER.

FOR CAP AND COLUMN REPAIR DETAILS, SEE "TYPICAL CAP AND COLUMN REPAIR DETAILS" SHEET.

FOR SHOTCRETE REPAIRS, SEE SPECIAL PROVISIONS.

FOR CONCRETE REPAIRS, SEE SPECIAL PROVISIONS.

FOR EPOXY RESIN INJECTION, SEE SPECIAL PROVISIONS.

PROJECT NO. **I-5950**  
**DAVIDSON** COUNTY  
 BRIDGE NO. **280147**

SHEET 2 OF 2

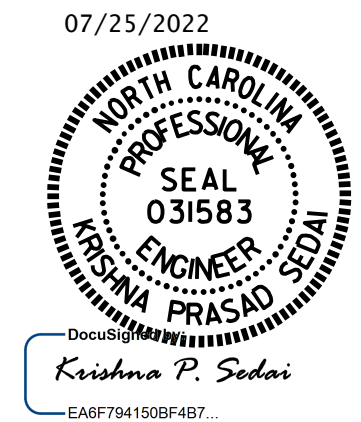

STATE OF NORTH CAROLINA  
 DEPARTMENT OF TRANSPORTATION  
 RALEIGH

**SUBSTRUCTURE REPAIR  
 BENT 1  
 SPAN B FACE**

REVISIONS						SHEET NO. S4-11
NO.	BY:	DATE:	NO.	BY:	DATE:	
1			3			TOTAL SHEETS 14
2			4			

DOCUMENT NOT CONSIDERED FINAL UNLESS ALL SIGNATURES COMPLETED

DRAWN BY : M. G. SHAIKH DATE : 09/2021  
 CHECKED BY : E. BAYISSA DATE : 03/2022

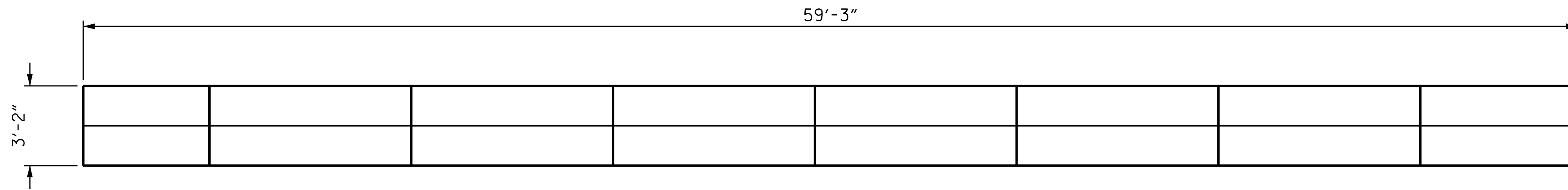

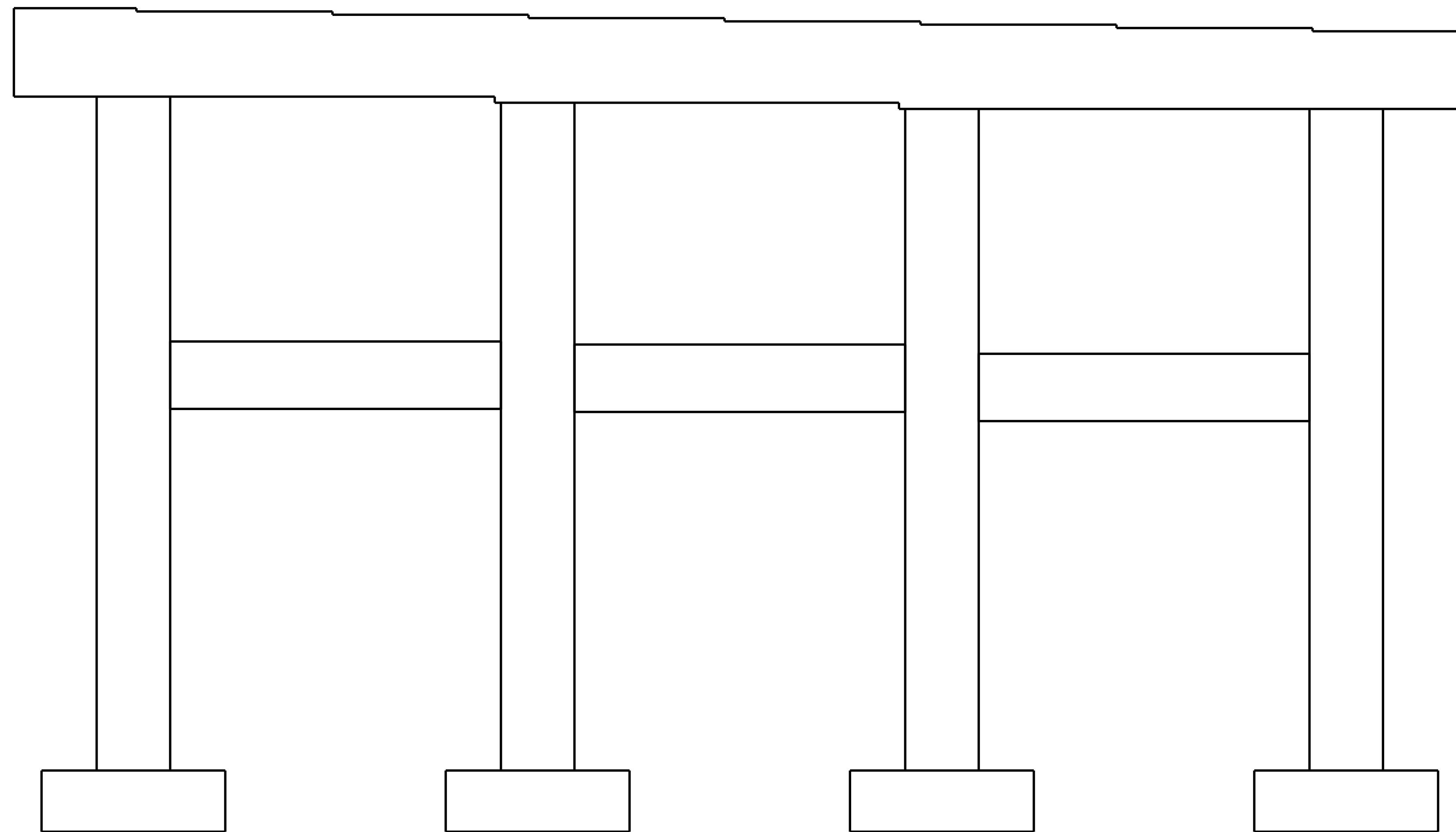

**PLAN - TOP OF CAP**

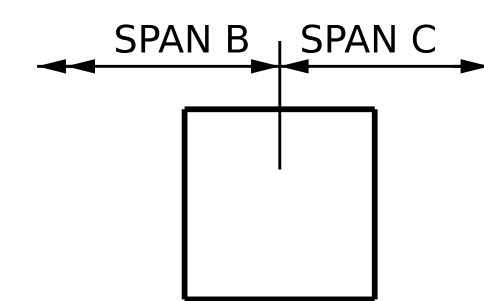

**ELEVATION**

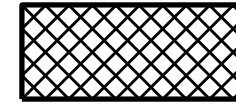
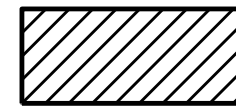

**END VIEW**

-  CONCRETE REPAIR AREA
-  SHOTCRETE REPAIR AREA
-  EPOXY RESIN INJECTION (ERI)

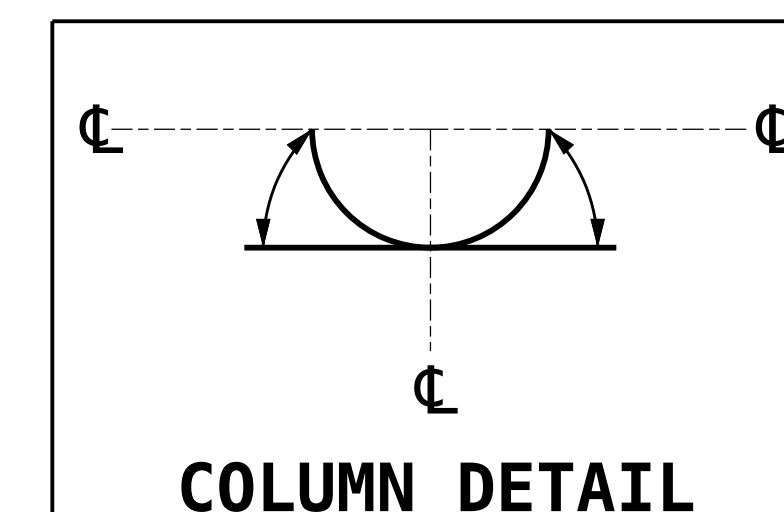

**COLUMN DETAIL**

AS-BUILT REPAIR QUANTITY TABLE				
BENT 2 SPAN B FACE	QUANTITIES			
	ESTIMATE		ACTUAL	
SHOTCRETE REPAIRS	AREA SQ. FT.	VOLUME CU. FT.	AREA SQ. FT.	VOLUME CU. FT.
CAP	0.0	0.0		
COLUMN	0.0	0.0		
CONCRETE REPAIRS	AREA SQ. FT.	VOLUME CU. FT.	AREA SQ. FT.	VOLUME CU. FT.
CAP	0.0	0.0		
COLUMN	0.0	0.0		
EPOXY RESIN INJECTION	LIN. FT.		LIN. FT.	
CAP	0.0			
COLUMN	0.0			
EPOXY COATING	SQ. FT.		SQ. FT.	
TOP OF BENT CAP	187.6			
TOP OF STRUT	111.4			

VALUES IN CHART REPRESENT ESTIMATED REPAIR TOTALS AFTER REMOVAL OF UNSOUND CONCRETE, MINIMUM OF 1" BEHIND REBAR AND MINIMUM OF 2" CLEARANCE TO SAWCUT.

**NOTES:**

REPAIR LOCATIONS AND ESTIMATE OF QUANTITIES ARE BASED ON THE BEST INFORMATION AVAILABLE. IF ADDITIONAL REPAIRS NOT SHOWN ON THE DRAWINGS ARE DEEMED NECESSARY BY THE ENGINEER, THE ENGINEER WILL NOTE ON THE DRAWINGS THE APPROXIMATE LOCATIONS AND DESCRIPTION OF THE REPAIRS AND ENTER THE ACTUAL QUANTITIES INTO THE AS-BUILT REPAIR QUANTITY TABLE.

CLEAN AND REMOVE DEBRIS FROM THE TOP OF THE CAP AND APPLY EPOXY PROTECTIVE COATING. EPOXY COATING SHALL BE APPLIED TO THE TOP SURFACE OF THE CAP. THE CONTRACTOR SHALL NOT COAT THE AREA OF THE CAP BENEATH THE MASONRY PLATES. FOR EPOXY COATING, SEE SPECIAL PROVISIONS.

SHOTCRETE REPAIRS MAY BE REPLACED WITH CONCRETE REPAIRS WITH THE APPROVAL OF THE ENGINEER.

FOR CAP AND COLUMN REPAIR DETAILS, SEE "TYPICAL CAP AND COLUMN REPAIR DETAILS" SHEET.

FOR SHOTCRETE REPAIRS, SEE SPECIAL PROVISIONS.

FOR CONCRETE REPAIRS, SEE SPECIAL PROVISIONS.

FOR EPOXY RESIN INJECTION, SEE SPECIAL PROVISIONS.

PROJECT NO. **I-5950**  
**DAVIDSON** COUNTY  
 BRIDGE NO. **280147**

SHEET 1 OF 2

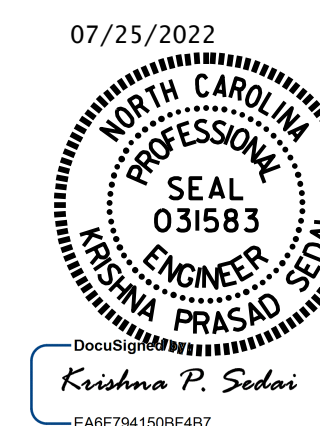

STATE OF NORTH CAROLINA  
 DEPARTMENT OF TRANSPORTATION  
 RALEIGH

**SUBSTRUCTURE REPAIR  
 BENT 2  
 SPAN B FACE**

DOCUMENT NOT CONSIDERED FINAL UNLESS ALL SIGNATURES COMPLETED

REVISIONS						SHEET NO.
NO.	BY:	DATE:	NO.	BY:	DATE:	S4-12
1			3			TOTAL SHEETS 14
2			4			

DRAWN BY : M. G. SHAIKH DATE : 09/2021  
 CHECKED BY : E. BAYISSA DATE : 03/2022

AS-BUILT REPAIR QUANTITY TABLE				
BENT 2 SPAN C FACE	QUANTITIES			
	ESTIMATE		ACTUAL	
SHOTCRETE REPAIRS	AREA SQ. FT.	VOLUME CU. FT.	AREA SQ. FT.	VOLUME CU. FT.
CAP	0.0	0.0		
COLUMN	0.0	0.0		
CONCRETE REPAIRS	AREA SQ. FT.	VOLUME CU. FT.	AREA SQ. FT.	VOLUME CU. FT.
CAP	0.0	0.0		
COLUMN	0.0	0.0		
EPOXY RESIN INJECTION		LIN. FT.		LIN. FT.
CAP		0.0		
COLUMN		0.0		

VALUES IN CHART REPRESENT ESTIMATED REPAIR TOTALS AFTER REMOVAL OF UNSOUND CONCRETE, MINIMUM OF 1" BEHIND REBAR AND MINIMUM OF 2" CLEARANCE TO SAWCUT.

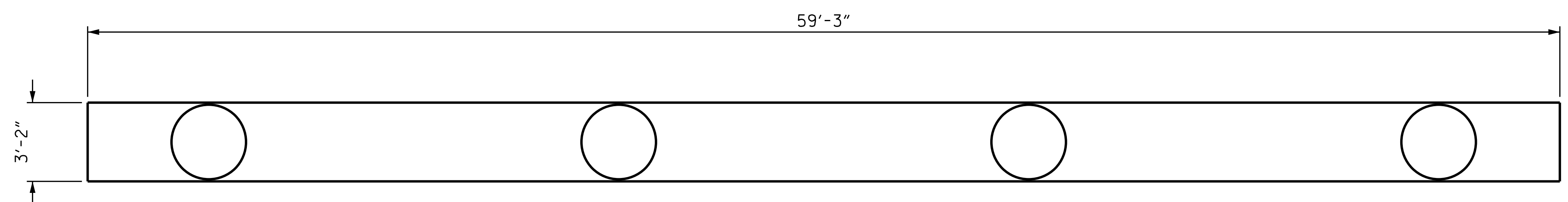

**PLAN - BOTTOM OF CAP**

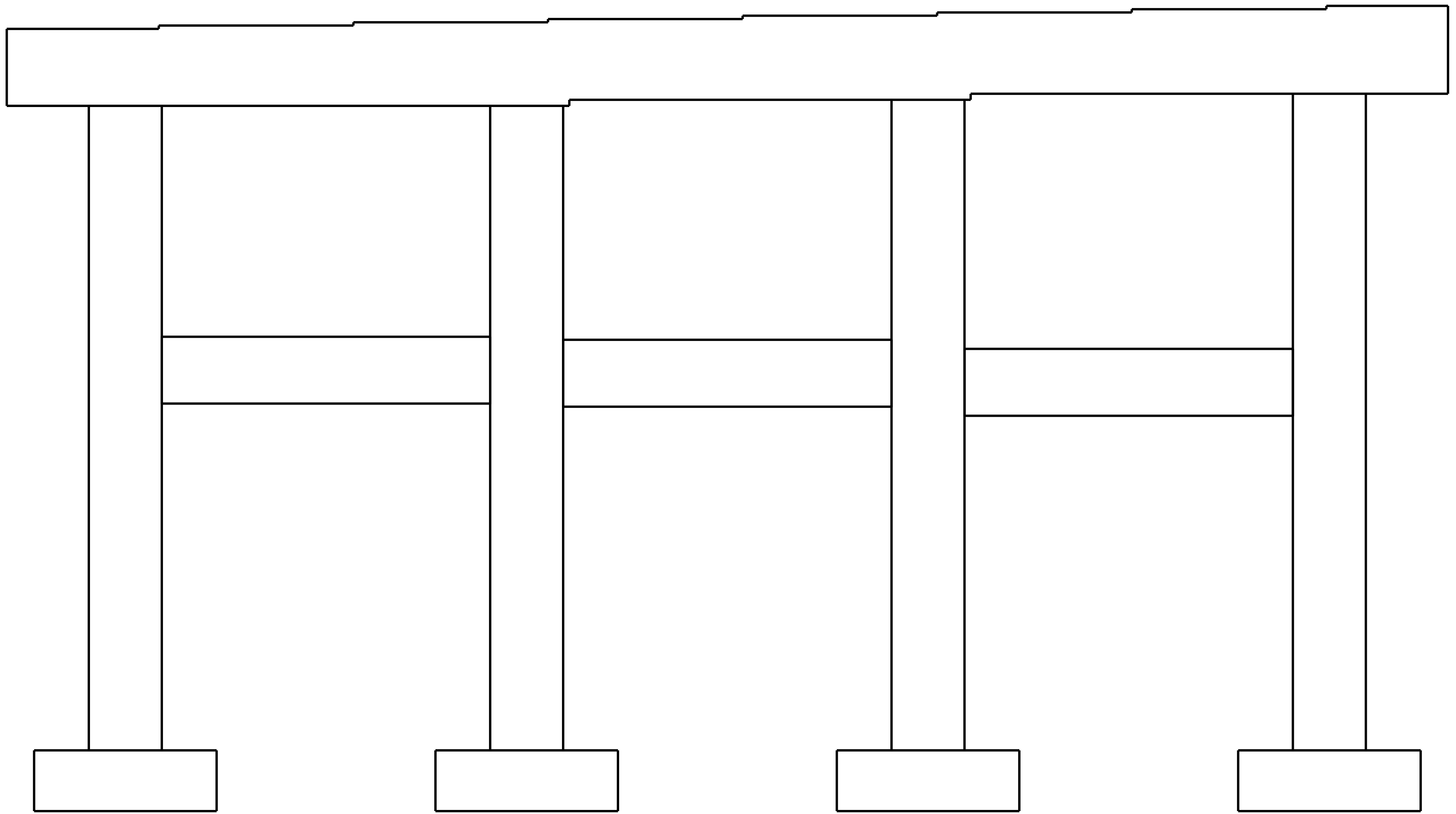

**ELEVATION**

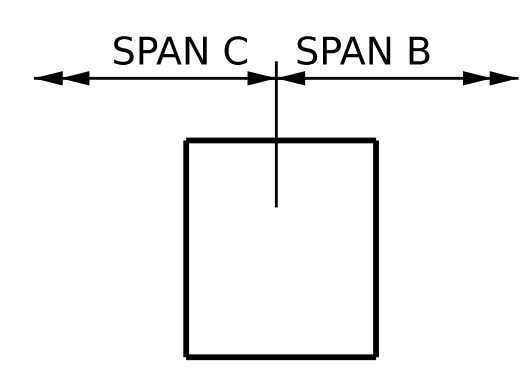

**END VIEW**

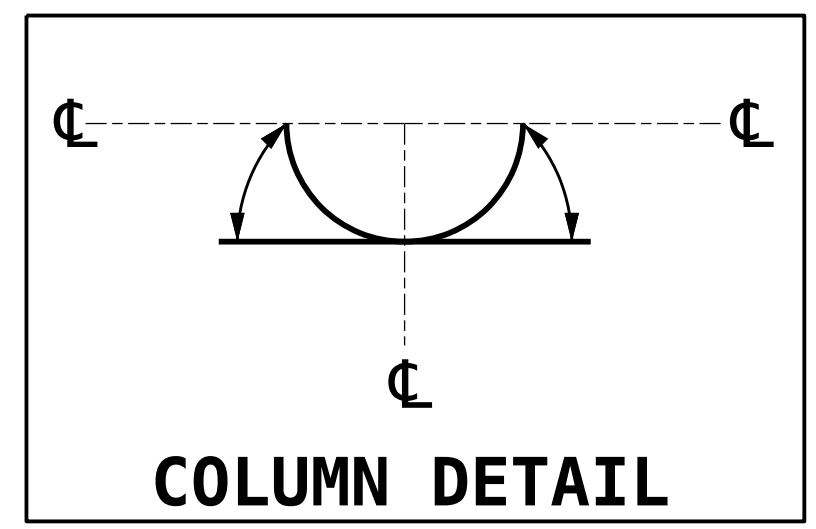

**COLUMN DETAIL**

**NOTES:**  
 REPAIR LOCATIONS AND ESTIMATE OF QUANTITIES ARE BASED ON THE BEST INFORMATION AVAILABLE. IF ADDITIONAL REPAIRS NOT SHOWN ON THE DRAWINGS ARE DEEMED NECESSARY BY THE ENGINEER, THE ENGINEER WILL NOTE ON THE DRAWINGS THE APPROXIMATE LOCATIONS AND DESCRIPTION OF THE REPAIRS AND ENTER THE ACTUAL QUANTITIES INTO THE AS-BUILT REPAIR QUANTITY TABLE.  
 SHOTCRETE REPAIRS MAY BE REPLACED WITH CONCRETE REPAIRS WITH THE APPROVAL OF THE ENGINEER.  
 FOR CAP AND COLUMN REPAIR DETAILS, SEE "TYPICAL CAP AND COLUMN REPAIR DETAILS" SHEET.  
 FOR SHOTCRETE REPAIRS, SEE SPECIAL PROVISIONS.  
 FOR CONCRETE REPAIRS, SEE SPECIAL PROVISIONS.  
 FOR EPOXY RESIN INJECTION, SEE SPECIAL PROVISIONS.

- CONCRETE REPAIR AREA
- SHOTCRETE REPAIR AREA
- EPOXY RESIN INJECTION (ERI)

PROJECT NO. **I-5950**  
**DAVIDSON** COUNTY  
 BRIDGE NO. **280147**

SHEET 2 OF 2

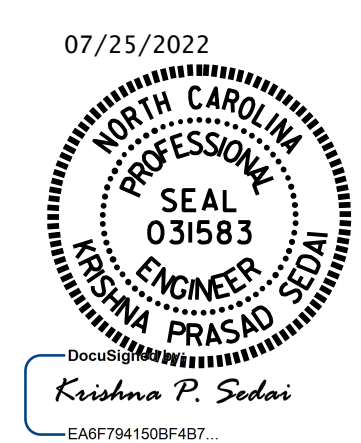

STATE OF NORTH CAROLINA  
 DEPARTMENT OF TRANSPORTATION  
 RALEIGH  
**SUBSTRUCTURE REPAIR  
 BENT 2  
 SPAN C FACE**

REVISIONS						SHEET NO. S4-13
NO.	BY:	DATE:	NO.	BY:	DATE:	
1			3			TOTAL SHEETS 14
2			4			

DOCUMENT NOT CONSIDERED FINAL UNLESS ALL SIGNATURES COMPLETED

DRAWN BY : M. G. SHAIKH DATE : 09/2021  
 CHECKED BY : E. BAYISSA DATE : 03/2022

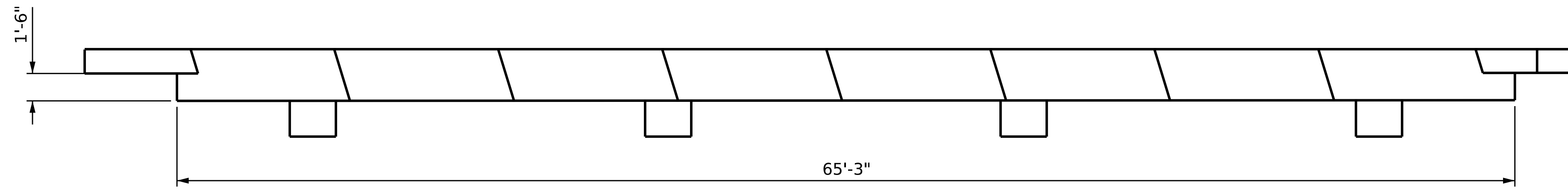

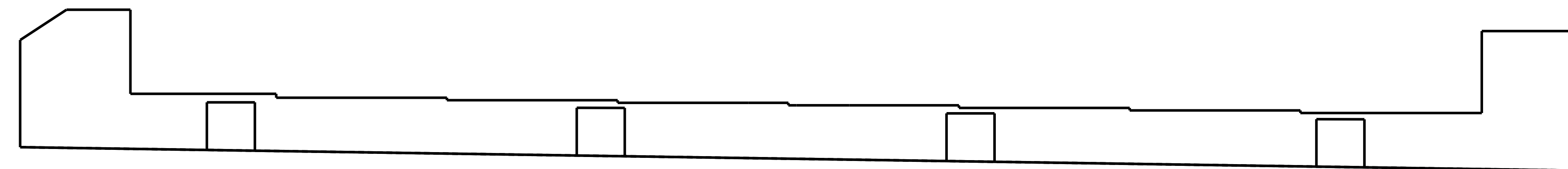

PLAN

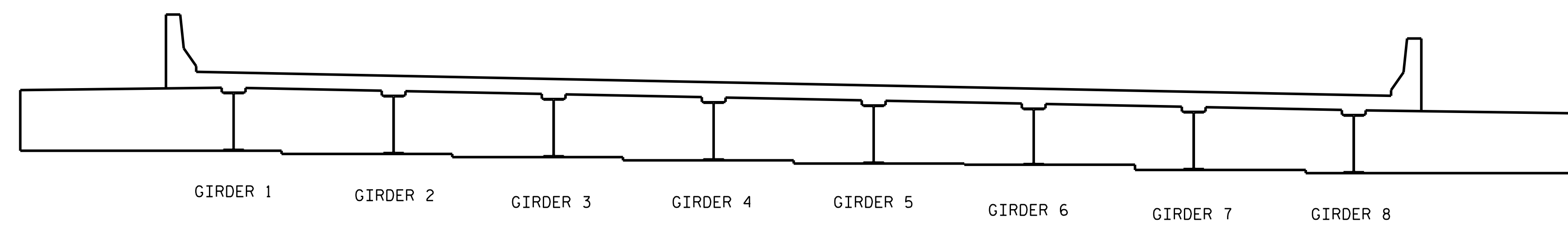

ELEVATION



TYPICAL SECTION

-  SHOTCRETE REPAIR AREA
-  CONCRETE REPAIR AREA
-  EPOXY RESIN INJECTION

AS-BUILT REPAIR QUANTITY TABLE				
REPAIRS - END BENT 2	QUANTITIES			
	ESTIMATE		ACTUAL	
SHOTCRETE REPAIRS	AREA SF	VOLUME CF	AREA SF	VOLUME CF
CAP	0.0	0.0		
CURTAIN WALL	0.0	0.0		
WINGWALL				
CONCRETE REPAIRS	AREA SF	VOLUME CF	AREA SF	VOLUME CF
CAP	0	0		
CURTAIN WALL	0	0		
WINGWALL				
EPOXY RESIN INJECTION		LINEAR FT		LINEAR FT
CAP		0		
CURTAIN WALL		0.0		
WINGWALL				
EPOXY COATING		AREA SF		AREA SF
CAP		97.9		
CURTAIN WALL		248.8		

VALUES IN CHART REPRESENT ESTIMATED REPAIR TOTALS AFTER REMOVAL OF UNSOUND CONCRETE, MIN. OF 1" BEHIND REBAR AND MIN. 2" CLEAR TO SAWCUT. SEE REPAIR DETAILS.

NOTES

REPAIR LOCATIONS AND ESTIMATE OF QUANTITIES ARE GIVEN BASED ON THE BEST INFORMATION AVAILABLE. IF ADDITIONAL REPAIRS NOT SHOWN ON THE DRAWINGS ARE DEEMED NECESSARY BY THE ENGINEER, THE ENGINEER SHALL NOTE ON THE DRAWINGS THE APPROXIMATE LOCATION AND DESCRIPTION OF THE REPAIRS AND ENTER THE ACTUAL QUANTITIES INTO THE AS-BUILT REPAIR QUANTITY TABLE.

CLEAN AND REMOVE DEBRIS FROM THE TOP OF THE CAP AND APPLY EPOXY PROTECTIVE COATING. EPOXY COATING SHALL BE APPLIED TO THE TOP SURFACE OF THE CAP. THE CONTRACTOR SHALL NOT COAT THE AREA OF THE CAP BENEATH THE MASONRY PLATES. FOR EPOXY COATING, SEE SPECIAL PROVISIONS.

SHOTCRETE REPAIRS MAYBE SUBSTITUTED IN LIEU OF CONCRETE REPAIRS WITH THE APPROVAL OF THE ENGINEER.

FOR CAP AND COLUMN REPAIRS, SEE "TYPICAL CAP AND COLUMN REPAIR DETAILS" SHEET.

FOR SHOTCRETE REPAIRS, SEE SPECIAL PROVISIONS.

FOR CONCRETE REPAIRS, SEE SPECIAL PROVISIONS.

FOR EPOXY RESIN INJECTION, SEE SPECIAL PROVISIONS.

PROJECT NO. **I-5950**  
**DAVIDSON** COUNTY  
 BRIDGE NO. **280147**

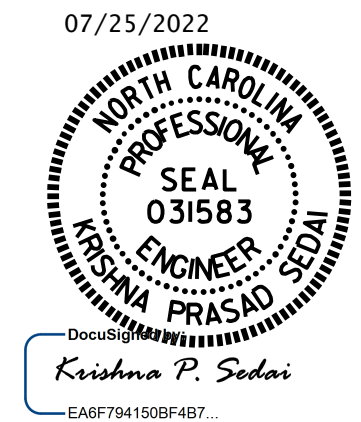

STATE OF NORTH CAROLINA  
 DEPARTMENT OF TRANSPORTATION  
 RALEIGH

**SUBSTRUCTURE REPAIR  
 END BENT 2**

REVISIONS						SHEET NO.
NO.	BY:	DATE:	NO.	BY:	DATE:	TOTAL SHEETS
1			3			14
2			4			

DRAWN BY : M. G. SHAIKH DATE : 09/2020  
 CHECKED BY : E. BAYISSA DATE : 04/2022

DOCUMENT NOT CONSIDERED  
 FINAL UNLESS ALL  
 SIGNATURES COMPLETED

**NOTES**

GENERAL DRAWING INFORMATION IS TAKEN FROM THE ORIGINAL PLANS AND THE ROUTINE INSPECTION REPORT DATED 4/27/2020.

BRIDGE ORIENTATION CONFORMS TO THE EXISTING BRIDGE PLANS/ROUTINE INSPECTION.

**SCOPE OF WORK**

PARTIALLY REMOVE TOP OF BRIDGE DECK CONCRETE BY SCARIFICATION AND SHOTBLASTING METHODS.

OVERLAY PREPARED TOP OF BRIDGE DECK WITH POLYMER CONCRETE (PC).

REMOVE EXISTING JOINT MATERIAL AND INSTALL FOAM JOINT SEALS FOR PRESERVATION.

GROOVE PC BRIDGE DECK.

EPOXY RESIN INJECTION OF CONCRETE CRACKS.

REMOVE DEBRIS FROM TOP OF EXISTING END BENT CAPS, AND APPLY EPOXY COATING.

REMOVE UNSOUND CONCRETE AND PROPERLY PREPARE EXISTING END BENT AND BENT AREAS FOR SHOTCRETE AND CONCRETE REPAIRS.

PROPERLY PREPARE SPALLED AREAS IN EXISTING END BENTS AND BENTS, AND PERFORM SHOTCRETE AND CONCRETE REPAIRS.

CLEAN AND PAINT EXISTING STEEL STRUCTURE.

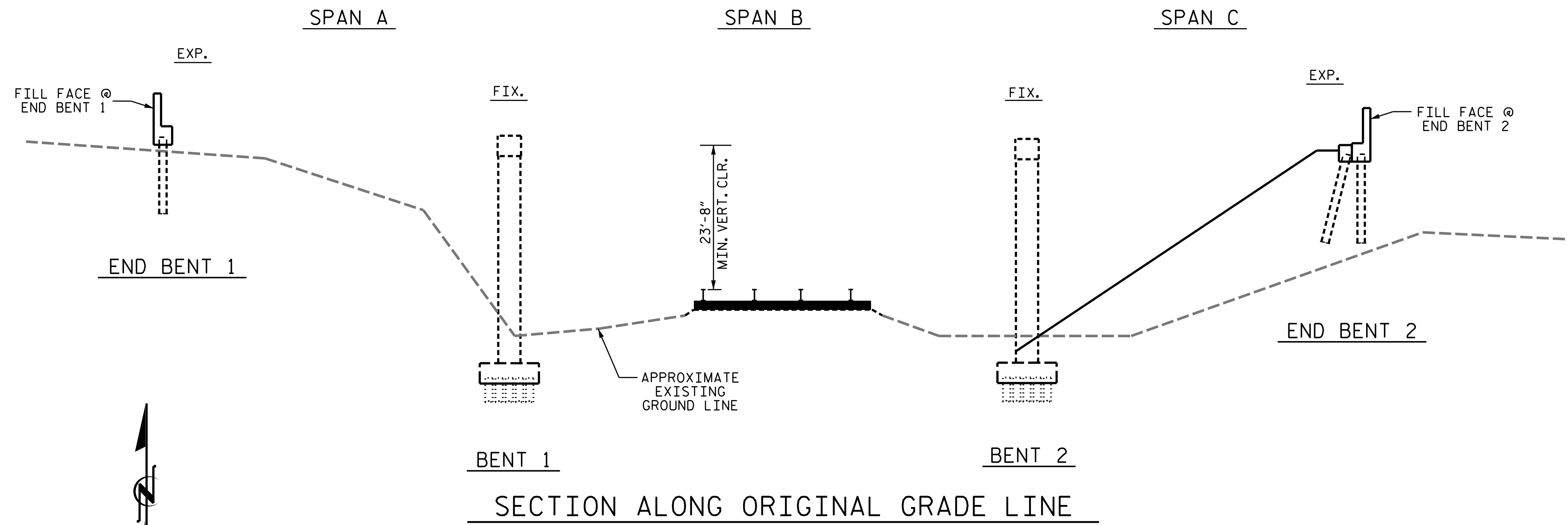

I HEREBY CERTIFY THAT THIS STRUCTURE WAS REHABILITATED ACCORDING TO THESE PLANS OR AS NOTED HEREIN.

RESIDENT ENGINEER \_\_\_\_\_ DATE \_\_\_\_\_

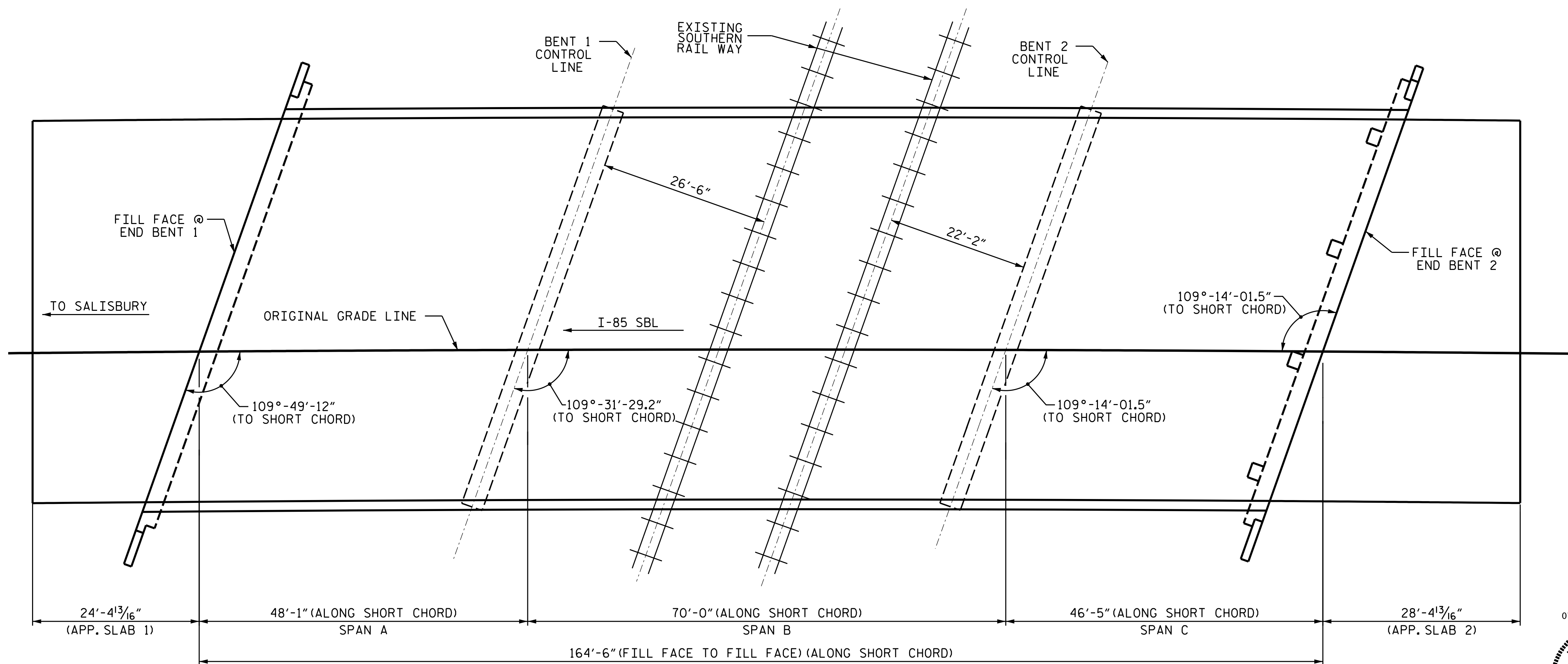

**PLAN**

PROJECT NO. I-5950  
DAVIDSON COUNTY  
 BRIDGE NO. 280152

SHEET 1 OF 2 MILE POST \*MN-320.870

STATE OF NORTH CAROLINA  
 DEPARTMENT OF TRANSPORTATION  
 RALEIGH

**GENERAL DRAWING  
 FOR BRIDGE ON I-85 SBL  
 OVER SOUTHERN RAILROAD**

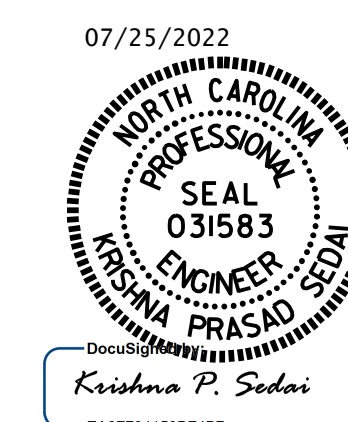
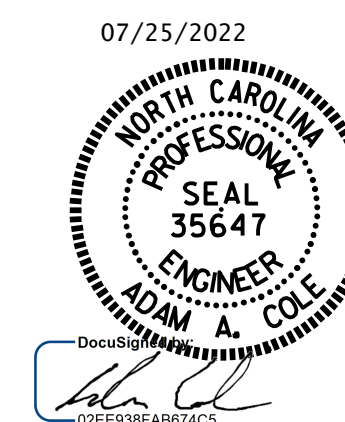

DRAWN BY : M. G. SHAIKH DATE : 08/2020  
 CHECKED BY : E. BAYISSA DATE : 04/2022

DOCUMENT NOT CONSIDERED  
 FINAL UNLESS ALL  
 SIGNATURES COMPLETED

REVISIONS						SHEET NO.
NO.	BY:	DATE:	NO.	BY:	DATE:	S5-01
1			3			TOTAL SHEETS
2			4			14

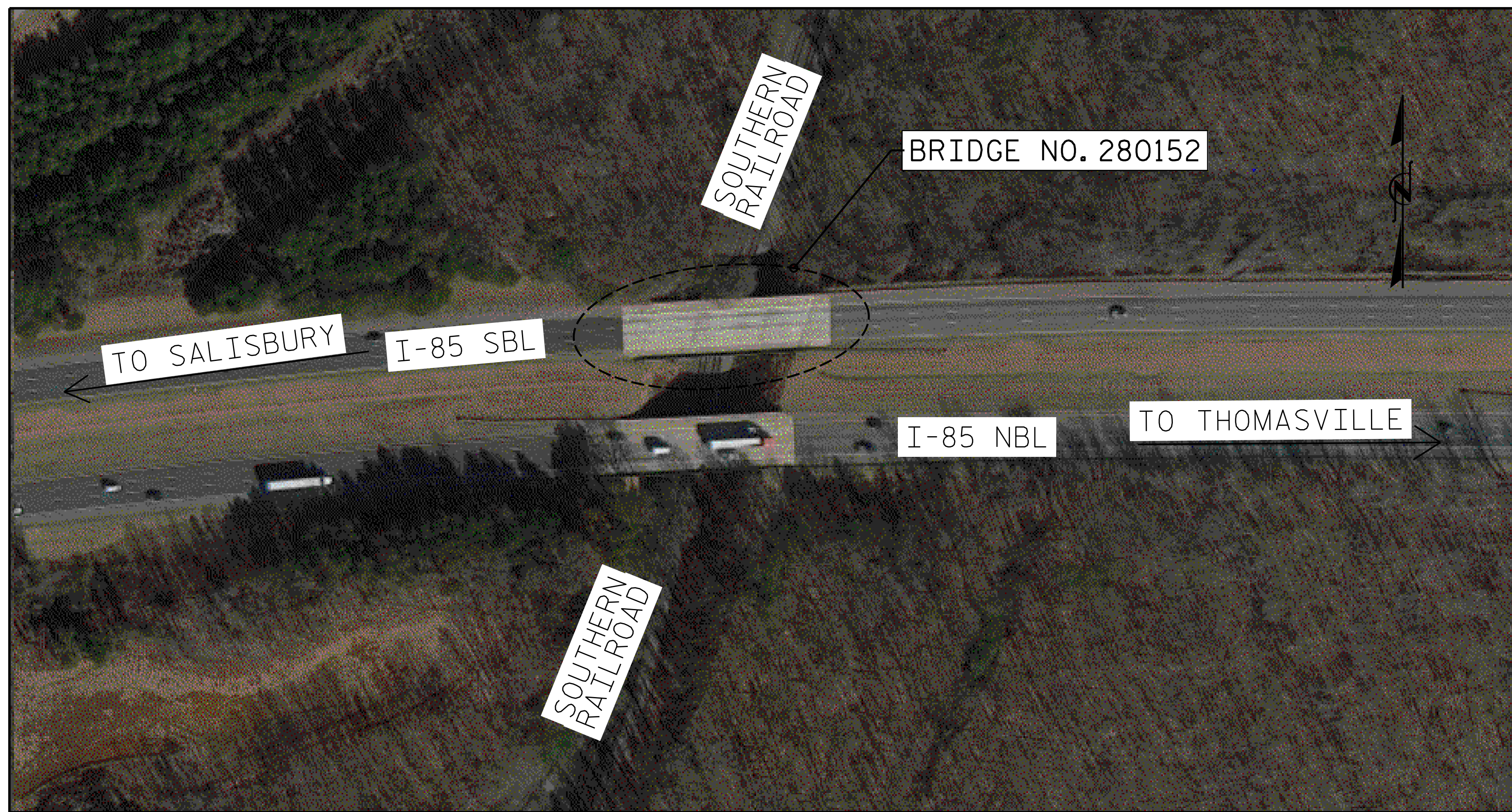

**LOCATION SKETCH**

**BRIDGE COORDINATES**

BRIDGE No.	LATITUDE	LONGITUDE
280152	35°-46'-36.98"	80°-17'-55.28"

**TOTAL BILL OF MATERIAL**

BRIDGE NO. 280152	GROOVING BRIDGE FLOORS	POLLUTION CONTROL	CLASS II SURFACE PREPARATION	CONCRETE REPAIRS	SHOTCRETE REPAIRS	EPOXY RESIN INJECTION	CLEANING & REPAINTING OF BRIDGE NO. 280152	PAINTING CONTAINMENT FOR BRIDGE NO. 280152	FOAM JOINT SEALS FOR PRESERVATION	POLYESTER POLYMER CONCRETE MATERIALS	EPOXY POLYMER CONCRETE MATERIALS (ALTERNATE)	EPOXY COATING	CONCRETE DECK REPAIR FOR POLYMER CONCRETE OVERLAY	PLACING & FINISHING POLYMER CONCRETE OVERLAY	SCARIFYING BRIDGE DECK	SHOTBLASTING BRIDGE DECK
	SQ. FT.	LUMP SUM	SQ. YDS.	CU. FT.	CU. FT.	LIN. FT.	LUMP SUM	LUMP SUM	LIN. FT.	CU. YDS.	CU. YDS.	SQ. FT.	SQ. YDS.	SQ. YDS.	SQ. YDS.	SQ. YDS.
TOTAL	11,315	LUMP SUM	13.2	1.8	9.2	15.5	LUMP SUM	LUMP SUM	118.8	46.4	46.4	1,293.6	13.2	1,338.0	1,338.0	1,338.0

**NOTES:**

INFORMATION INDICATED ON THE LOCATION SKETCH SHALL BE CONSIDERED GENERAL INFORMATION ONLY. THE CONTRACTOR SHALL CONFIRM, THROUGH OTHER SOURCES, SPECIFIC INFORMATION REGARDING BRIDGES, ROADWAYS, UTILITIES, THE SURROUNDING AREA, AND ANY OTHER ASPECTS THAT MAY BE NECESSARY TO PERFORM AND COMPLETE THE PROJECT.

EXISTING DIMENSIONS AND BRIDGE CONDITION ARE FROM THE BEST INFORMATION AVAILABLE. THE CONTRACTOR SHALL FIELD VERIFY THE INFORMATION SHOWN ON THE PLANS AND NOTIFY THE ENGINEER IF ACTUAL DIMENSIONS AND CONDITIONS DIFFER.

THE CONTRACTOR SHALL HAVE NO CLAIM WHATSOEVER AGAINST THE DEPARTMENT FOR ANY DELAYS OF ADDITIONAL COST INCURRED BASED ON DIFFERENCES BETWEEN WHAT IS SHOWN ON THE PLANS AND THE ACTUAL CONDITIONS AT THE PROJECT SITE.

IT IS THE CONTRACTOR'S RESPONSIBILITY TO FOLLOW ALL STATE AND FEDERAL SAFETY REQUIREMENTS.

FOR CONTROL OF TRAFFIC AND LIMITS ON PHASING OF CONSTRUCTION, SEE TRANSPORTATION MANAGEMENT PLANS.

EXISTING JOINTS AND DECK DRAINS SHALL BE SEALED PRIOR TO BEGINNING SURFACE PREPARATIONS OF THE BRIDGE DECK. THE CONTRACTOR SHALL TAKE CARE THAT ANY CONSTRUCTION DEBRIS THAT COLLECTS IN THE DRAINS IS CONTAINED. DRAINS IN SHOULDERS OF ADJACENT TRAVEL LANE(S) SHALL BE KEPT FREE AND CLEAR OF DEBRIS.

LONGITUDINAL CONSTRUCTION JOINTS OF OVERLAYS SHALL BE LOCATED ALONG THE CENTERLINE OR EDGE OF TRAVEL LANES.

FOR FOAM JOINT SEALS FOR PRESERVATION, SEE SPECIAL PROVISIONS.

FOR EPOXY RESIN INJECTION, SEE SPECIAL PROVISIONS.

FOR CONCRETE REPAIRS, SEE SPECIAL PROVISIONS.

FOR SHOTCRETE REPAIRS, SEE SPECIAL PROVISIONS.

FOR SUBMITTAL OF WORKING DRAWINGS, SEE SPECIAL PROVISIONS.

FOR FALSEWORK AND FORMWORK, SEE SPECIAL PROVISIONS.

FOR CRANE SAFETY, SEE SPECIAL PROVISIONS.

FOR SCARIFYING BRIDGE DECK, SHOTBLASTING BRIDGE DECK AND CLASS II SURFACE PREPARATION, SEE OVERLAY SURFACE PREPARATION FOR POLYMER CONCRETE SPECIAL PROVISION.

FOR CONCRETE DECK REPAIR FOR PC OVERLAY, PC MATERIALS, MAND PLACING AND FINISHING PC OVERLAY, SEE POLYMER CONCRETE BRIDGE DECK OVERLAY SPECIAL PROVISION.

THE CONTRACTOR SHALL PERFORM ALL WORK WITH CARE SO THAT THE EXISTING STRUCTURE WHICH IS TO REMAIN IN PLACE WILL NOT BE DAMAGED. IF THE CONTRACTOR DAMAGES ANY PART OF THE EXISTING STRUCTURE WHICH IS TO REMAIN IN PLACE, THE DAMAGED AREA SHALL BE REPAIRED OR REPLACED IN A MANNER SATISFACTORY TO THE ENGINEER AT NO ADDITIONAL COST TO THE DEPARTMENT.

SHOTCRETE REPAIRS MAY BE REPLACED WITH CONCRETE REPAIRS WITH THE APPROVAL OF THE ENGINEER.

THE CONTRACTOR SHALL FIELD VERIFY THE EXISTING JOINT OPENING PRIOR TO ORDERING JOINT SEAL MATERIAL. IF ACTUAL JOINT OPENING VARIES FROM THE OPENING INDICATED IN DETAIL BY MORE THAN 1/4", NOTIFY ENGINEER. REVISION TO THE JOINT SEAL SIZE MIGHT BE NECESSARY.

FOR GROUT FOR STRUCTURES, SEE SPECIAL PROVISIONS.

THE EXISTING BRIDGE DECK SHALL BE REPAIRED AS SHOWN ON THE PLANS OR AS DETERMINED BY THE ENGINEER AFTER SCARIFICATION AND PRIOR TO THE SURFACE PREPARATION AND APPLICATION OF THE PC OVERLAY. UNLESS OTHERWISE APPROVED, SUCH LOCATIONS SHALL BE REPAIRED WITH POLYMER CONCRETE.

FOR EPOXY COATING AND DEBRIS REMOVAL, SEE SPECIAL PROVISIONS.

WORK ON THE BRIDGE SHALL BE PERFORMED SO AS NOT TO ALLOW DEBRIS TO FALL BELOW. THE CONTRACTOR SHALL SUBMIT PLANS FOR CONSTRUCTION IN ACCORDANCE WITH ARTICLE 402-2 OF THE STANDARD SPECIFICATIONS AND THE PROJECT SPECIAL PROVISIONS.

PRIOR TO BEGINNING WORK, THE CONTRACTOR SHALL SUBMIT FOR REVIEW AND APPROVAL A COMPLETE SEQUENCE OF TASKS FOR EACH OPERATION AFFECTING THE BRIDGE SURFACE AND/OR TRAFFIC.

THE CONTRACTOR SHALL PROVIDE INDEPENDENT ASSURANCE SAMPLES OF REINFORCING STEEL AS FOLLOWS: FOR PROJECTS REQUIRING UP TO 400 TONS OF REINFORCING STEEL, ONE 30 INCH SAMPLE OF EACH SIZE BAR USED, AND FOR PROJECTS REQUIRING OVER 400 TONS OF REINFORCING STEEL, TWO 30 INCH SAMPLES OF EACH SIZE BAR USED. THE SAMPLE BARS SHOULD COME FROM STEEL ACTUALLY USED IN THE PROJECT AND THE SAMPLE BARS SHOULD BE REPLACED BY SPLICED BARS AS SPECIFIED IN THE SAMPLE BAR REPLACEMENT CHART. PAYMENT FOR THE SAMPLE BARS AND REPLACEMENT REINFORCING STEEL SHALL BE CONSIDERED INCIDENTAL TO VARIOUS PAY ITEMS.

FOR PAINTING CONTAINMENT, POLLUTION CONTROL AND CLEANING & REPAINTING BRIDGE, SEE SPECIAL PROVISIONS.

FOR ANCHOR BOLT NUT REPLACEMENT AND TIGHTENING, SEE SPECIAL PROVISIONS.

PROJECT NO. I-5950  
DAVIDSON COUNTY  
 BRIDGE NO. 280152

SHEET 2 OF 2

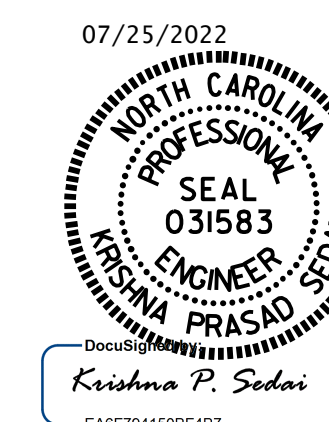

STATE OF NORTH CAROLINA  
 DEPARTMENT OF TRANSPORTATION  
 RALEIGH

**GENERAL DRAWING  
 FOR BRIDGE ON I-85 SBL  
 OVER SOUTHERN RAILROAD**

DRAWN BY : M. G. SHAIKH DATE : 08/2020  
 CHECKED BY : E. BAYISSA DATE : 04/2022

DOCUMENT NOT CONSIDERED  
 FINAL UNLESS ALL  
 SIGNATURES COMPLETED

REVISIONS						SHEET NO.
NO.	BY:	DATE:	NO.	BY:	DATE:	S5-02
1			3			TOTAL SHEETS
2			4			14

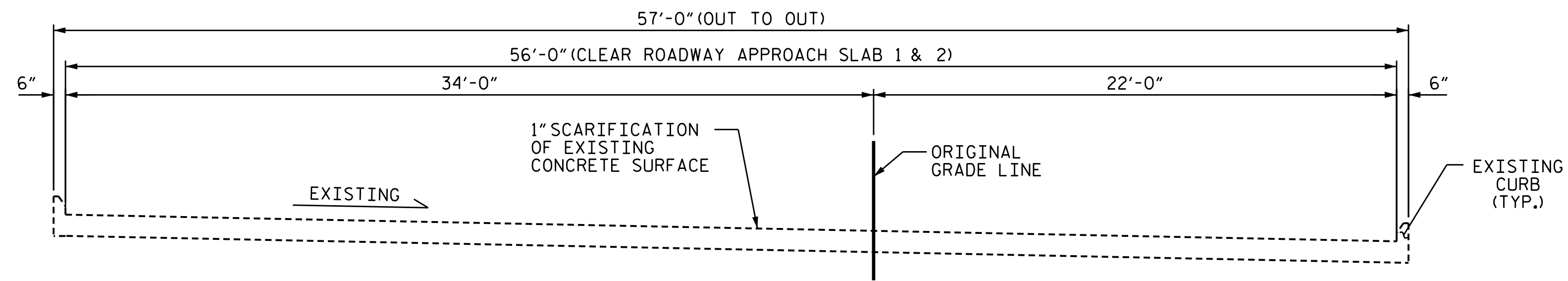

TYPICAL SECTION - APPROACH SLAB  
(EXISTING)

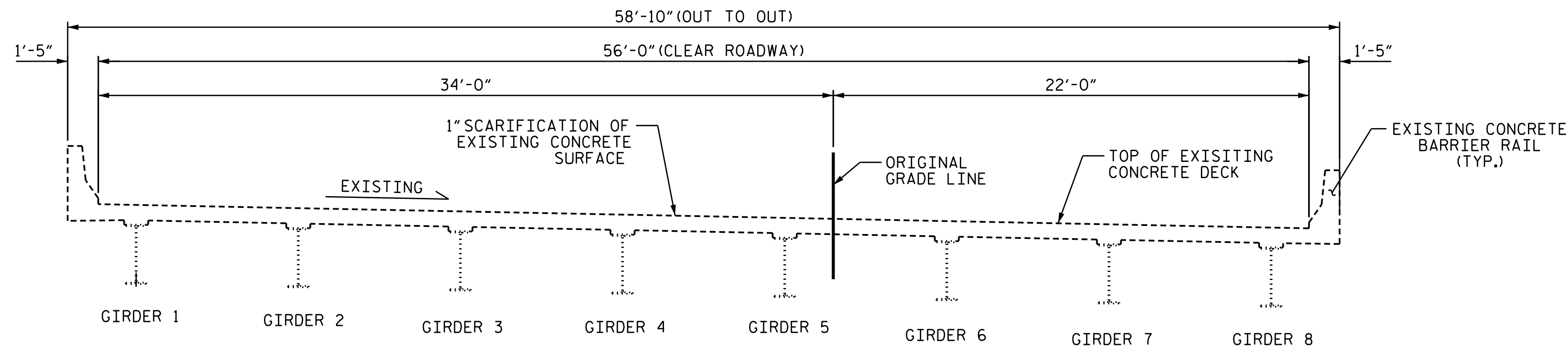

TYPICAL SECTION  
(EXISTING)

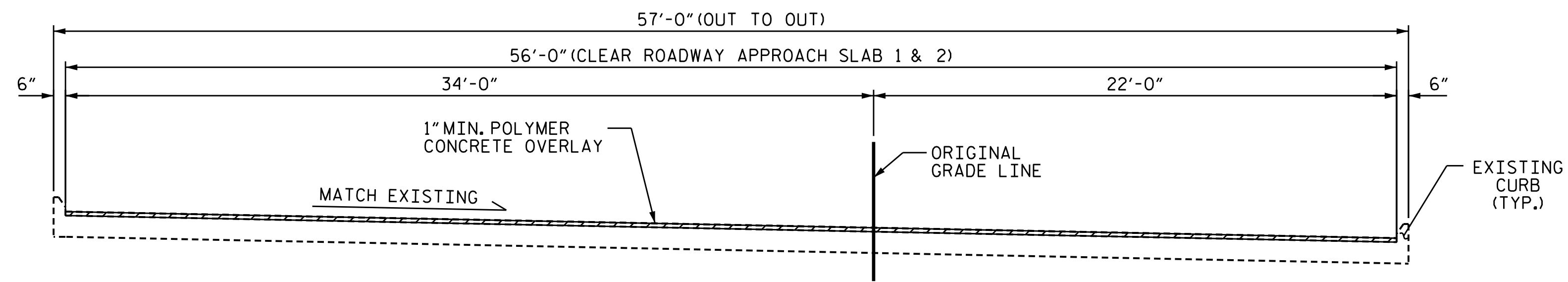

TYPICAL SECTION - APPROACH SLAB  
(PROPOSED)

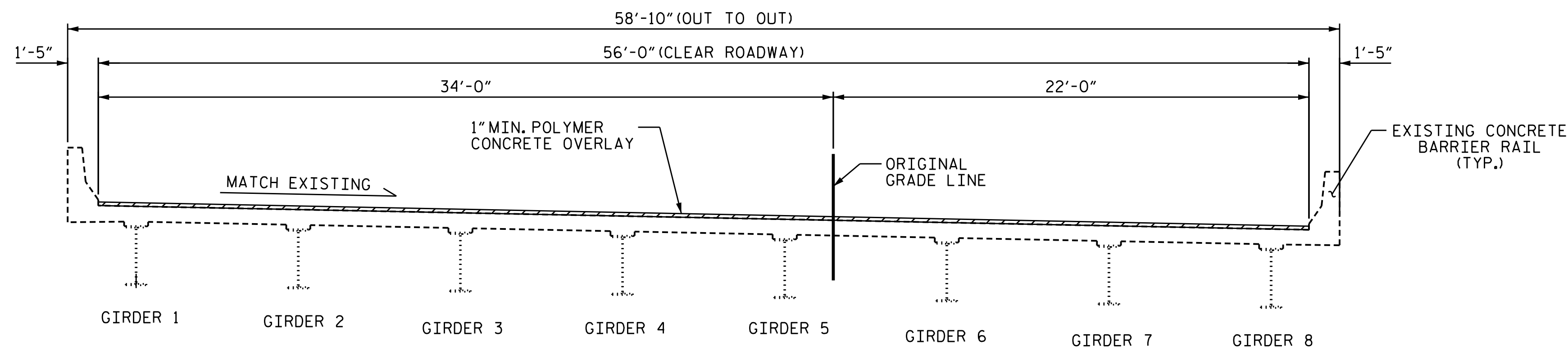

TYPICAL SECTION  
(PROPOSED)

NOTES

SEE TRANSPORTATION MANAGEMENT PLANS FOR LANE WIDTHS, SEQUENCING AND OTHER TRAFFIC CONTROL MEASURES FOR STAGING OF POLYMER CONCRETE (PC) OVERLAY SYSTEM AND SURFACE PREPARATION.

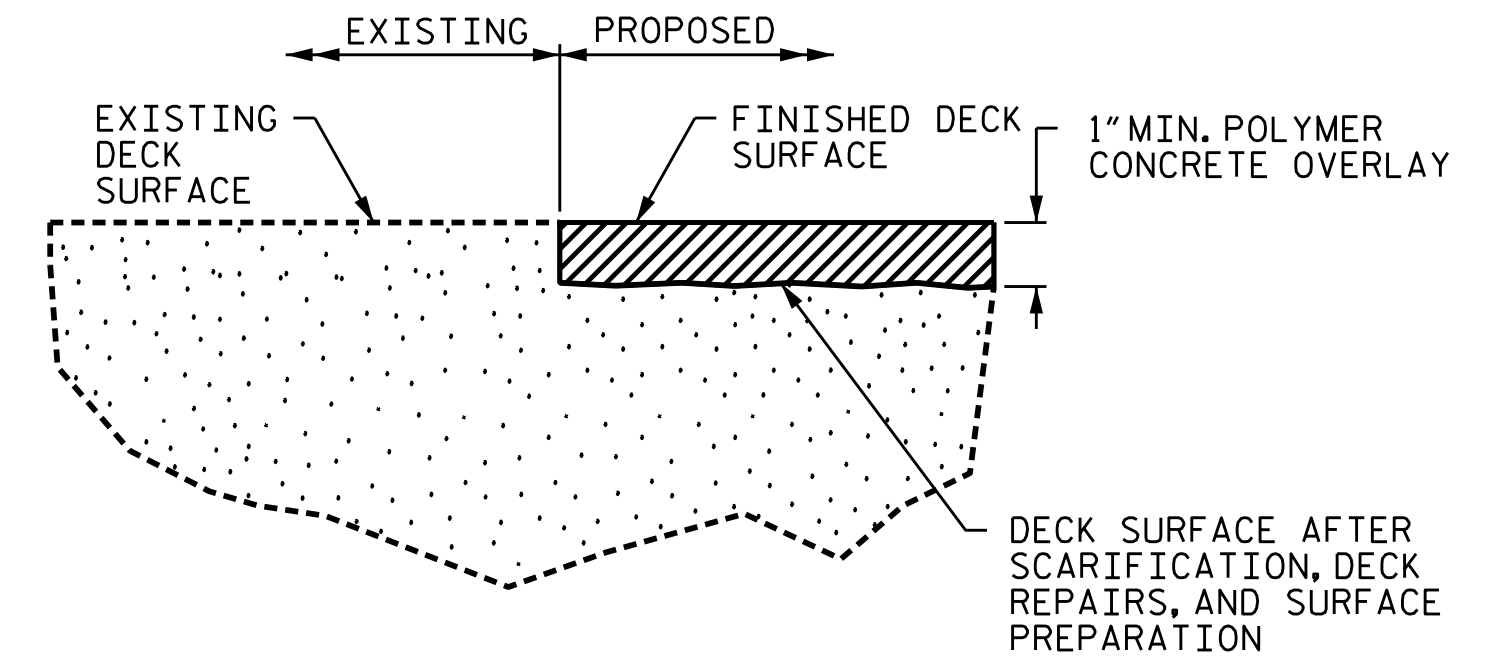

DETAIL FOR POLYMER CONCRETE OVERLAY

FINISHED SURFACE ELEVATION SHALL MATCH EXISTING CONCRETE SURFACE ELEVATION. ACTUAL THICKNESS OF PC OVERLAY MAY VARY.

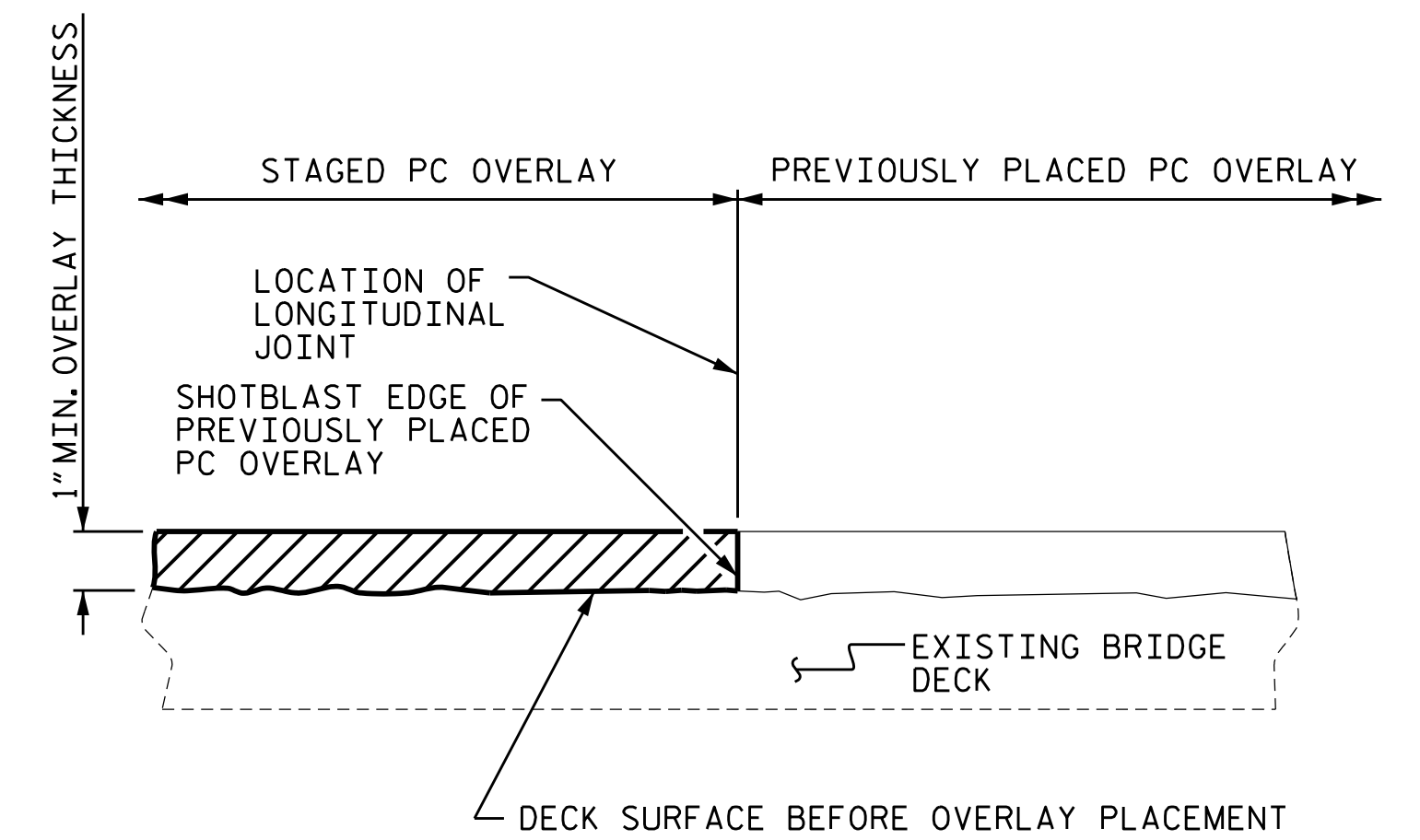

STAGED PC OVERLAY JOINT  
(AS NEEDED)

PROJECT NO. I-5950  
DAVIDSON COUNTY  
BRIDGE NO. 280152

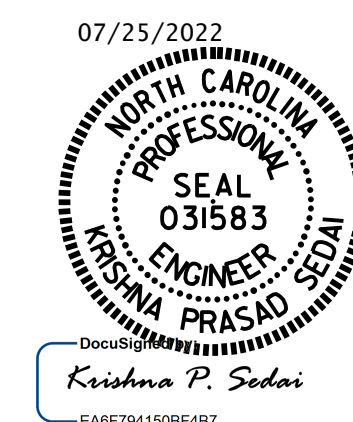

STATE OF NORTH CAROLINA  
DEPARTMENT OF TRANSPORTATION  
RALEIGH  
SUPERSTRUCTURE  
TYPICAL SECTION  
AND PC  
OVERLAY DETAILS

DRAWN BY : M. G. SHAIKH DATE : 09/2020  
CHECKED BY : E. BAYISSA DATE : 04/2022

DOCUMENT NOT CONSIDERED  
FINAL UNLESS ALL  
SIGNATURES COMPLETED

REVISIONS						SHEET NO.
NO.	BY:	DATE:	NO.	BY:	DATE:	S5-03
1			3			TOTAL SHEETS
2			4			14



**NOTES:**



REPAIR LOCATIONS AND ESTIMATE OF QUANTITIES ARE BASED ON THE BEST INFORMATION AVAILABLE. IF ADDITIONAL REPAIRS NOT SHOWN ON THE DRAWINGS ARE DEEMED NECESSARY BY THE ENGINEER, THE ENGINEER WILL NOTE ON THE DRAWINGS THE APPROXIMATE LOCATIONS AND DESCRIPTION OF THE REPAIRS AND ENTER THE ACTUAL QUANTITIES INTO THE AS-BUILT REPAIR QUANTITY TABLE.

FOR CONCRETE DECK REPAIR FOR PC OVERLAY, PC MATERIALS, AND PLACING AND FINISHING PC OVERLAY, SEE POLYMER CONCRETE BRIDGE DECK OVERLAY SPECIAL PROVISION.

FOR SECTION A-A, SEE "JOINT DETAILS" SHEET.

TOP OF DECK SURFACE REPAIR QUANTITIES REPRESENT ESTIMATED VALUES OF CLASS II SURFACE PREPARATION AND CONCRETE DECK REPAIR AFTER REMOVAL OF UNSOUND CONCRETE (MIN. 2" CLEAR TO SAWCUT). SEE CONCRETE FOR DECK REPAIR SPECIAL PROVISION.

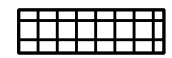
FOR SCARIFYING BRIDGE DECK, SHOTBLASTING BRIDGE DECK AND CLASS II SURFACE PREPARATION, SEE OVERLAY SURFACE PREPARATION FOR POLYMER CONCRETE SPECIAL PROVISION.

-  CLASS II SURFACE PREPARATION
-  SHOTCRETE REPAIR
-  CONCRETE REPAIR
-  EPOXY RESIN INJECTION (ERI)

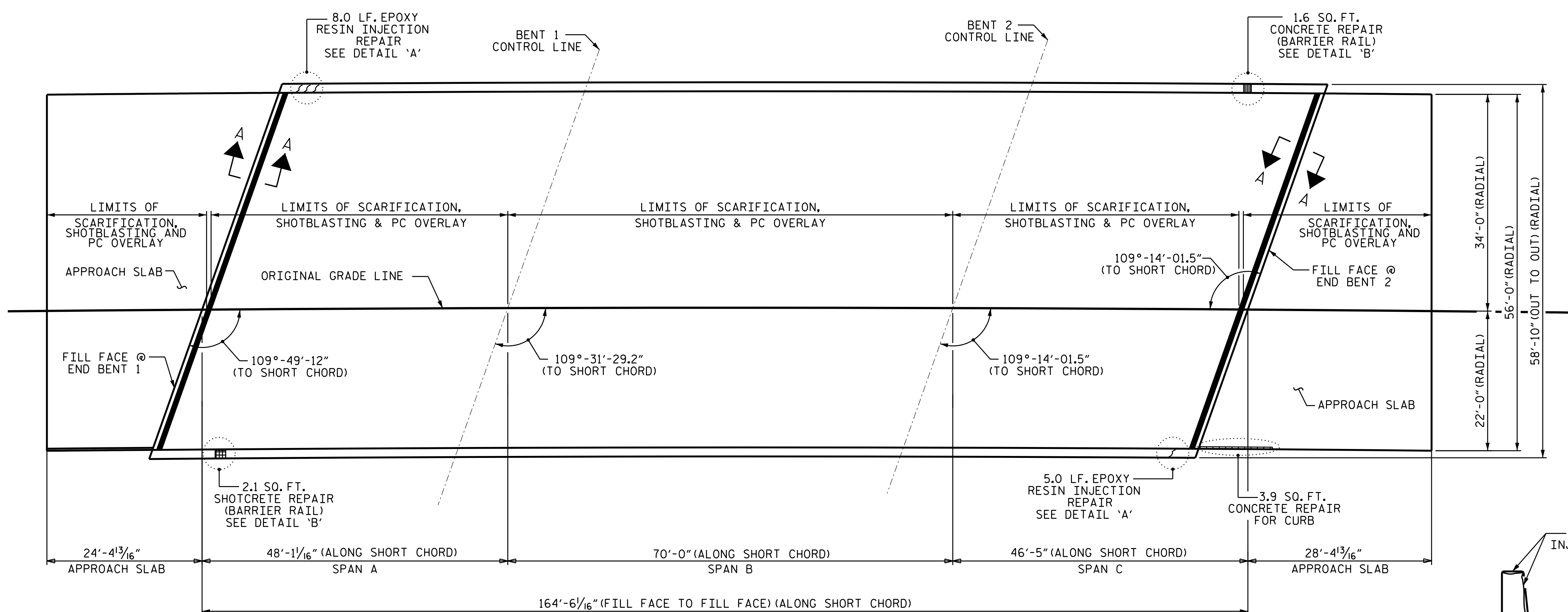

**PLAN OF SPANS**

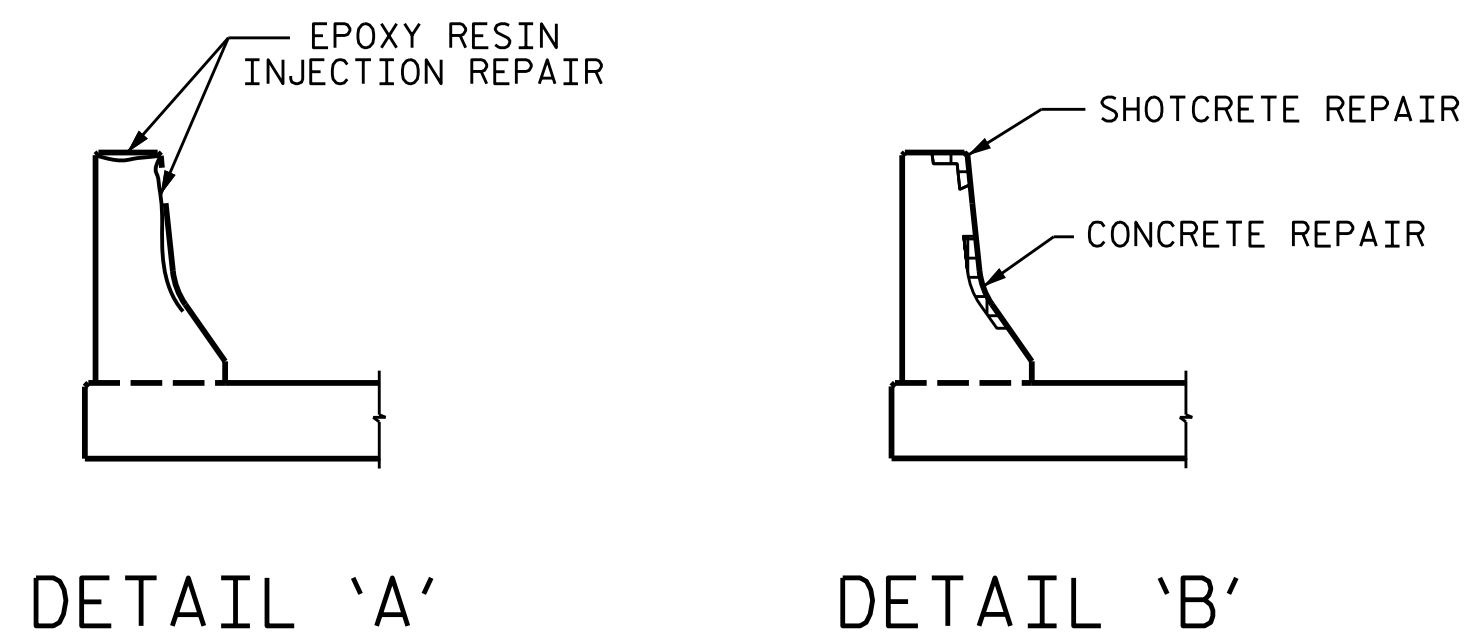

**DETAIL 'A'**

**DETAIL 'B'**

**AS-BUILT REPAIR QUANTITY TABLE**

TOP OF DECK REPAIRS	APPROACH SLAB 1		SPAN A		SPAN B		SPAN C		APPROACH SLAB 2	
	ESTIMATE	ACTUAL	ESTIMATE	ACTUAL	ESTIMATE	ACTUAL	ESTIMATE	ACTUAL	ESTIMATE	ACTUAL
SCARIFYING BRIDGE DECK	162.2 SQ. YDS.		295.3 SQ. YDS.		435.5 SQ. YDS.		284.8 SQ. YDS.		160.2 SQ. YDS.	
SHOTBLASTING BRIDGE DECK	162.2 SQ. YDS.		295.3 SQ. YDS.		435.5 SQ. YDS.		284.8 SQ. YDS.		160.2 SQ. YDS.	
CLASS II SURFACE PREPARATION	3.3 SQ. YDS.		3.3 SQ. YDS.		0.0 SQ. YDS.		3.3 SQ. YDS.		3.3 SQ. YDS.	
CONCRETE DECK REPAIR FOR PC OVERLAY	3.3 SQ. YDS.		3.3 SQ. YDS.		0.0 SQ. YDS.		3.3 SQ. YDS.		3.3 SQ. YDS.	
POLYMER CONCRETE MATERIALS	5.6 CU. YDS.		10.3 CU. YDS.		15.1 CU. YDS.		9.9 CU. YDS.		5.5 CU. YDS.	
PLACING & FINISHING PC OVERLAY	162.2 SQ. YDS.		295.3 SQ. YDS.		435.5 SQ. YDS.		284.9 SQ. YDS.		160.2 SQ. YDS.	
GROOVING BRIDGE FLOOR	1340.0 SQ. FT.		2514.0 SQ. FT.		3710.0 SQ. FT.		2425.0 SQ. FT.		1326.0 SQ. FT.	
EPOXY RESIN INJECTION	0.0 LIN. FT.		8.0 LIN. FT.		0.0 LIN. FT.		5.0 LIN. FT.		0.0 LIN. FT.	
SHOTCRETE REPAIRS	ESTIMATE	ACTUAL	ESTIMATE	ACTUAL	ESTIMATE	ACTUAL	ESTIMATE	ACTUAL	ESTIMATE	ACTUAL
	AREA SQ. FT.	VOLUME CU. FT.	AREA SQ. FT.	VOLUME CU. FT.	AREA SQ. FT.	VOLUME CU. FT.	AREA SQ. FT.	VOLUME CU. FT.	AREA SQ. FT.	VOLUME CU. FT.
CONCRETE BARRIER RAIL	0.0	0.0			2.1	0.7	0.0	0.0	0.0	0.0
CONCRETE REPAIRS	ESTIMATE	ACTUAL	ESTIMATE	ACTUAL	ESTIMATE	ACTUAL	ESTIMATE	ACTUAL	ESTIMATE	ACTUAL
	AREA SQ. FT.	VOLUME CU. FT.	AREA SQ. FT.	VOLUME CU. FT.	AREA SQ. FT.	VOLUME CU. FT.	AREA SQ. FT.	VOLUME CU. FT.	AREA SQ. FT.	VOLUME CU. FT.
CONCRETE BARRIER RAIL	0.0	0.0			0.0	0.0	0.0	0.0	0.0	0.0
CURB	0.0	0.0			0.0	0.0	0.0	0.0	3.9	1.3

PROJECT NO. I-5950  
DAVIDSON COUNTY  
 BRIDGE NO. 280152

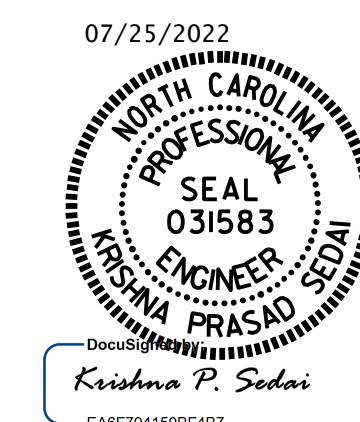

STATE OF NORTH CAROLINA  
 DEPARTMENT OF TRANSPORTATION  
 RALEIGH

**DECK SURFACE REPAIR AND APPROACH SLAB**

DRAWN BY : M. G. SHAIKH DATE : 09/2020  
 CHECKED BY : E. BAYISSA DATE : 04/2022

REVISIONS						SHEET NO.
NO.	BY:	DATE:	NO.	BY:	DATE:	S5-04
1			3			TOTAL SHEETS
2			4			14

**NOTE**

THE CONTRACTOR SHALL FIELD VERIFY THE EXISTING JOINT OPENING PRIOR TO ORDERING JOINT SEAL MATERIAL. IF ACTUAL JOINT OPENING VARIES FROM THE OPENING INDICATED IN DETAIL BY MORE THAN 1/4", NOTIFY ENGINEER. REVISION TO THE JOINT SEAL SIZE MIGHT BE NECESSARY.

FINAL JOINT SEALS SHALL NOT BE INSTALLED UNTIL THE OVERLAY IS COMPLETE.

THE CONTRACTOR SHALL TAKE CARE DURING JOINT REHAB OPERATIONS NOT TO DROP ANY MATERIAL BELOW THE BRIDGE WITHOUT PROTECTIVE DEVICES BELOW TO CATCH THE MATERIAL. ANY MATERIAL THAT FALLS BELOW THE BRIDGE SHALL BE CONTAINED, REMOVED AND DISPOSED OF BY THE CONTRACTOR AT NO EXTRA COST TO THE DEPARTMENT. IF THE ENGINEER DETERMINES THAT THE PROTECTIVE DEVICES ARE NOT ADEQUATE OR NOT BEING EMPLOYED, THE WORK SHALL BE SUSPENDED UNTIL ADEQUATE PROTECTION IS PROVIDED.

THE CONTRACTOR WILL NOT BE PERMITTED TO FORM THE JOINTS IN LIEU OF SAWING THE JOINT.

THE INSTALLATION OF THE JOINT SEAL SHALL BE WATERTIGHT.

DURING THE JOINT INSTALLATION PROCEDURE, THE JOINT AND SURROUNDING AREA SHALL BE KEPT CLEAN AND FREE OF DEBRIS.

THE MANUFACTURER IS TO PROVIDE THE NOMINAL UNCOMPRESSED SEAL WIDTH OF THE FOAM JOINT SEAL FOR THE SIZE OF THE OPENING ON THE PLANS AND THAT ACCOMMODATE THE MINIMUM EXPANSION SHOWN ON THE PLANS.

A MANUFACTURER'S CERTIFIED TRAINED REPRESENTATIVE SHALL BE PRESENT DURING THE INSTALLATION OF THE FIRST JOINT OF THE PROJECT, OR UNTIL THE ENGINEER IS SATISFIED WITH THE INSTALL PROCESS.

FINAL SURFACE OF THE JOINT DEMOLITION AREA PRIOR TO PLACEMENT OF CONCRETE REPAIR MATERIAL SHOULD BE REASONABLY FLAT AND LEVEL. ENGINEER SHALL DETERMINE THE ACCEPTABILITY OF THE SURFACE PRIOR TO PLACEMENT OF REPAIR CONCRETE.

FOR FOAM JOINT SEALS FOR PRESERVATION, SEE SPECIAL PROVISIONS.

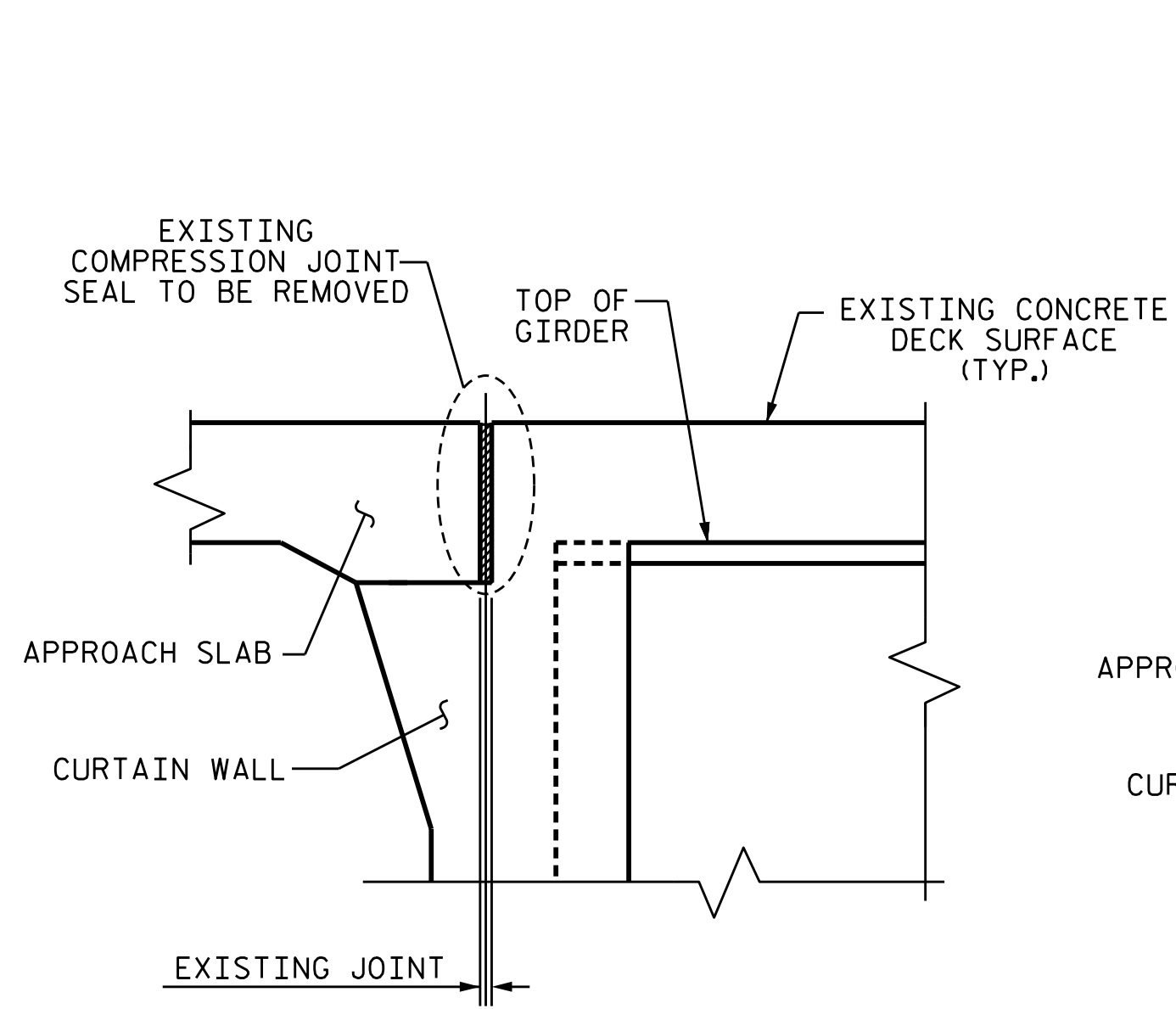

EXISTING JOINT

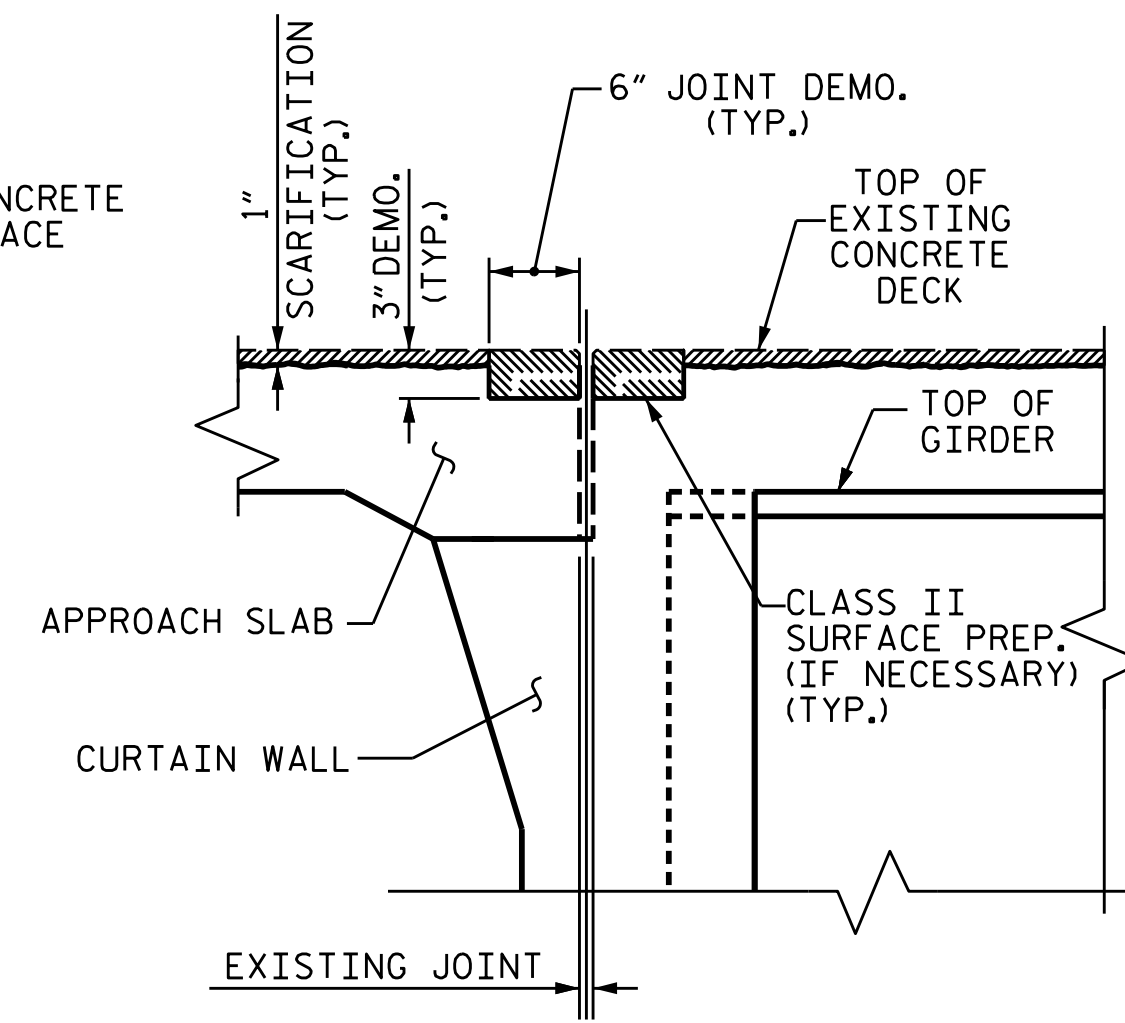

MINIMUM EXISTING JOINT DEMOLITION & SCARIFICATION

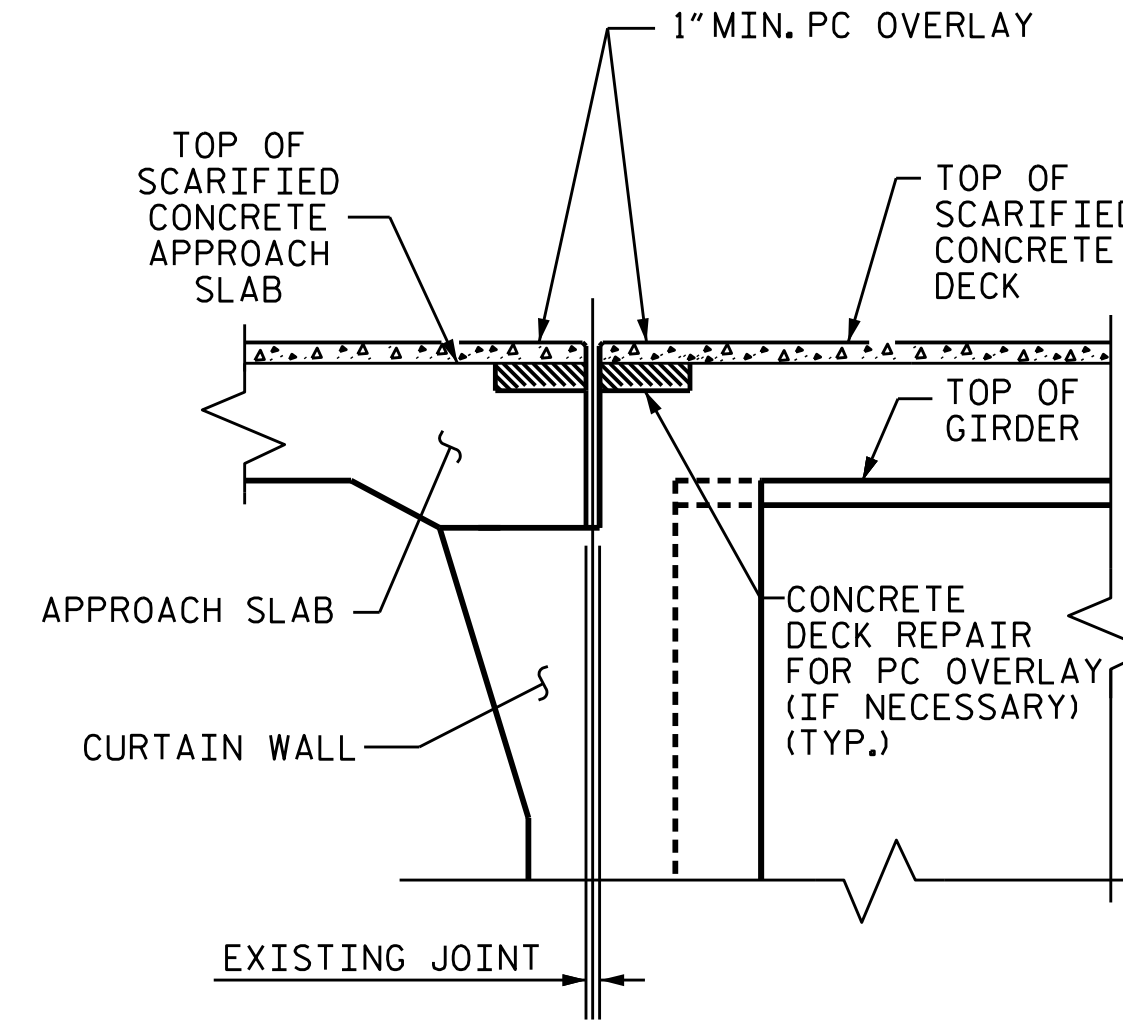

PROPOSED JOINT PRE-SAWED & PC OVERLAY

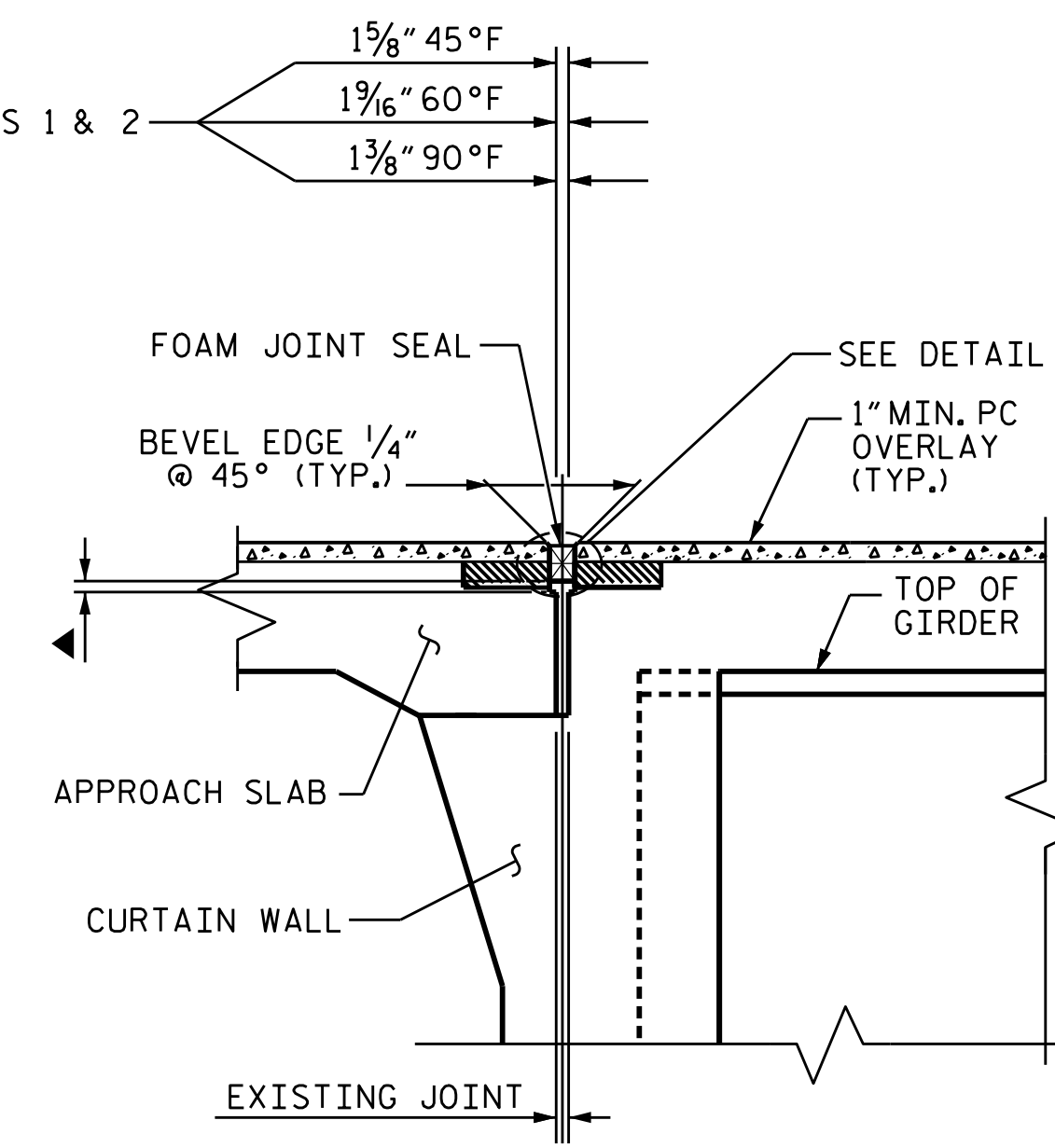

PROPOSED FOAM JOINT SEAL

▲ SAW CUT SHALL BE 1" BELOW THE BOTTOM OF FOAM JOINT SEAL. SEE MANUFACTURER RECOMMENDATIONS

JOINT INSTALLATION SEQUENCE AT END BENTS

SECTION A-A

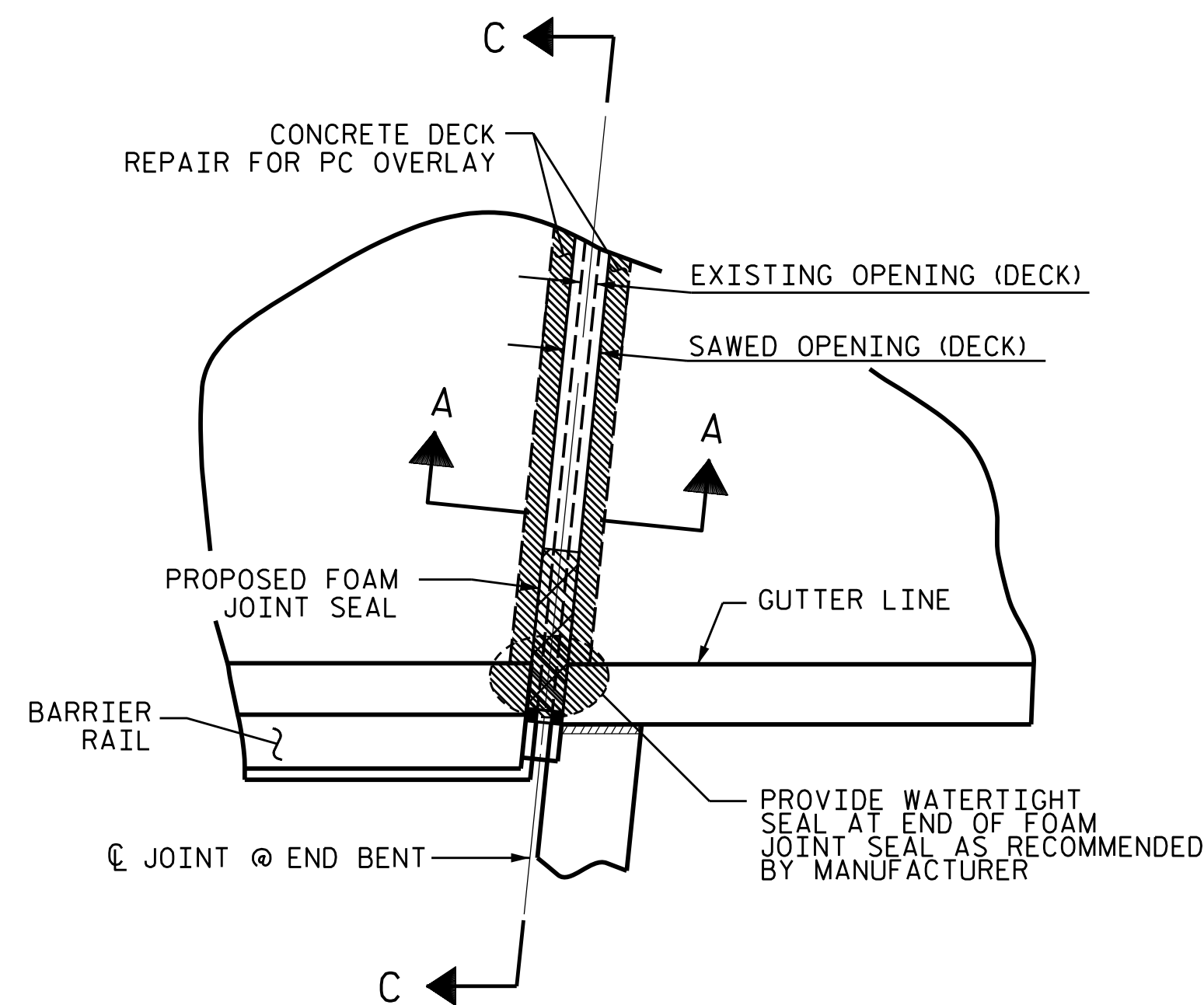

PLAN

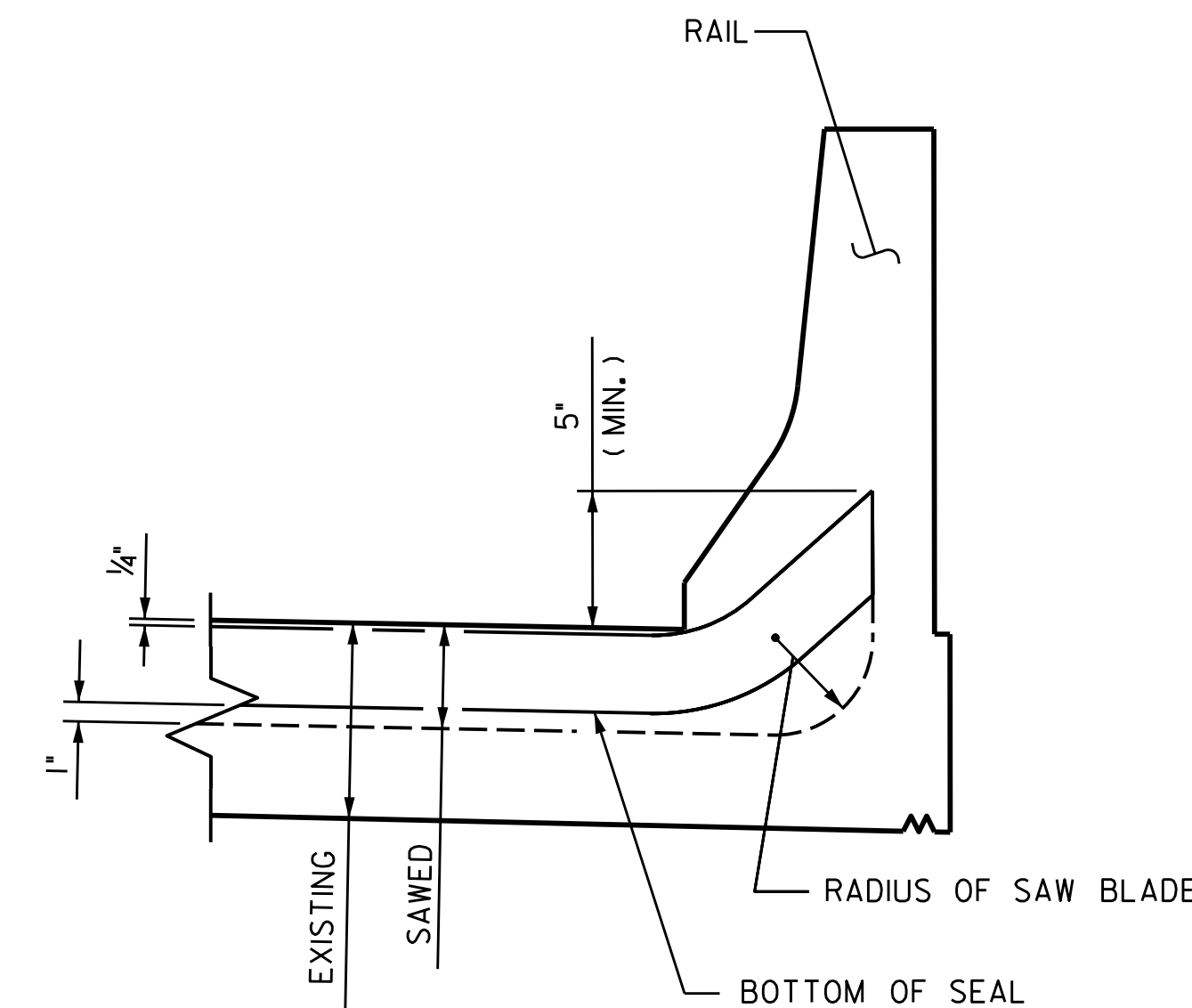

SECTION C-C

JOINT REPAIR QUANTITY TABLE		
	ESTIMATE	ACTUAL
FOAM JOINT SEAL FOR PRESERVATION		
END BENT 1	59.5 LF	
END BENT 2	59.3 LF	
TOTAL	118.8 LF	

PROJECT NO. I-5950  
DAVIDSON COUNTY  
 BRIDGE NO. 280152

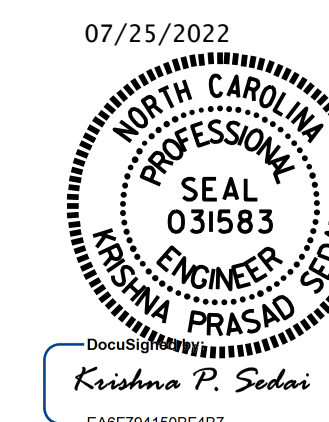

STATE OF NORTH CAROLINA  
 DEPARTMENT OF TRANSPORTATION  
 RALEIGH

**JOINT DETAILS**

DRAWN BY: M. G. SHAIKH DATE: 10/2020  
 CHECKED BY: E. BAYISSA DATE: 03/2022

7/25/2022  
 SANDP331-I-5950\Final Plans\405\_009\_I5950\_SMU.JT\_S05\_280152.dgn  
 ksedai

DOCUMENT NOT CONSIDERED  
 FINAL UNLESS ALL  
 SIGNATURES COMPLETED

REVISIONS						SHEET NO.
NO.	BY:	DATE:	NO.	BY:	DATE:	
1			3			S5-05
2			4			TOTAL SHEETS 14

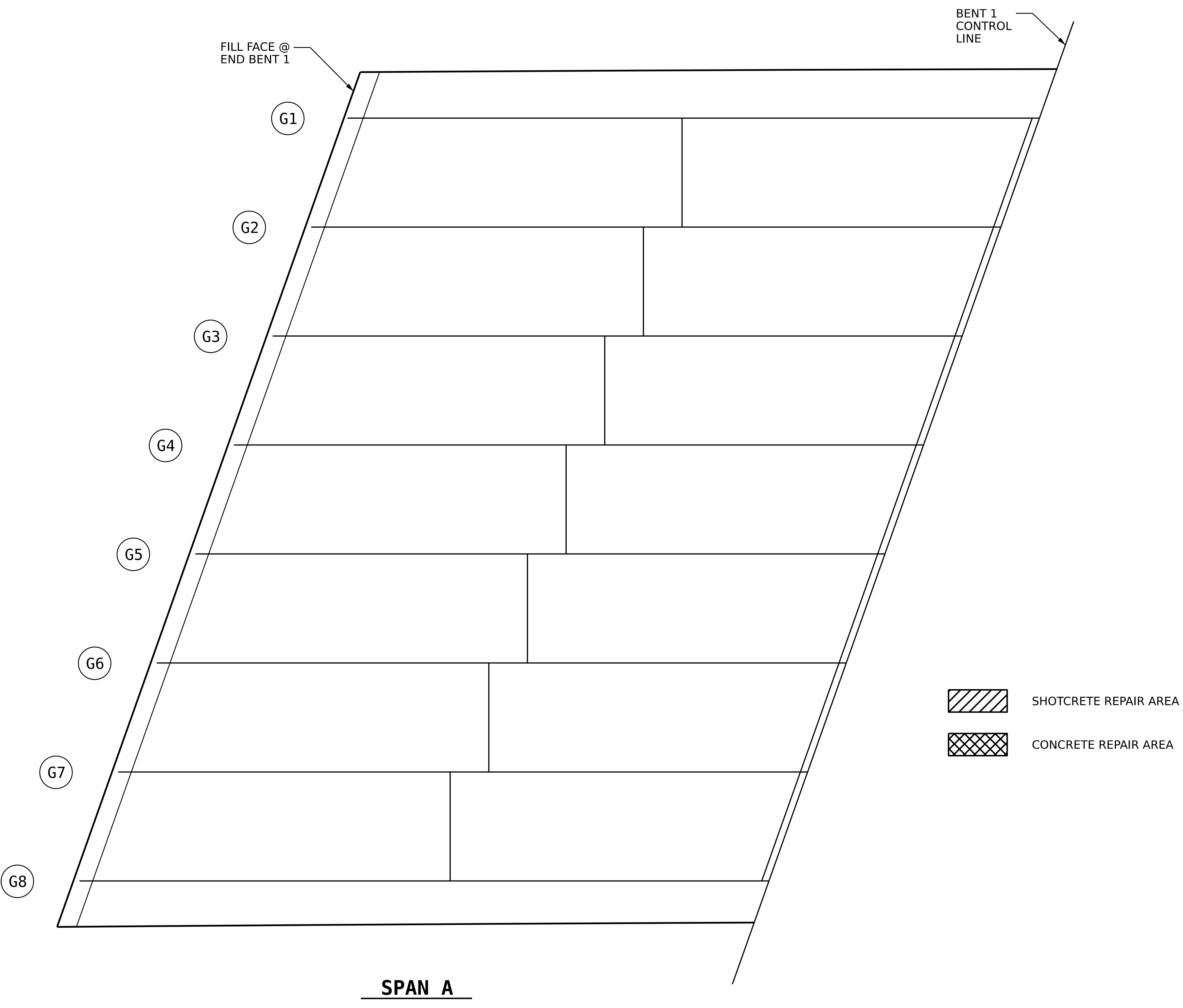

### AS-BUILT REPAIR QUANTITY TABLE

DECK UNDERSIDE REPAIRS SPAN A	QUANTITIES			
	ESTIMATE		ACTUAL	
SHOTCRETE REPAIRS	AREA SF	VOLUME CF	AREA SF	VOLUME CF
UNDERSIDE OF DECK	0.0	0.0		
CONCRETE DIAPHRAGM	0.0	0.0		
OVERHANG	0.0	0.0		
CONCRETE REPAIRS	AREA SF	VOLUME CF	AREA SF	VOLUME CF
UNDERSIDE OF DECK	0.0	0.0		
CONCRETE DIAPHRAGM	0.0	0.0		
OVERHANG	0.0	0.0		
EPOXY RESIN INJECTION		LIN. FT.		LIN. FT.
UNDERSIDE OF DECK		0.0		
CONCRETE DIAPHRAGM		0.0		
OVERHANG		0.0		

VALUES IN CHART REPRESENT ESTIMATED REPAIR TOTALS AFTER REMOVAL OF UNSOUND CONCRETE, MIN. OF 1" BEHIND REBAR AND MIN. 2" CLEAR TO SAWCUT. SEE REPAIR DETAILS.

#### NOTES

REPAIR LOCATIONS AND ESTIMATE OF QUANTITIES ARE GIVEN BASED ON THE BEST INFORMATION AVAILABLE. IF ADDITIONAL REPAIRS NOT SHOWN ON THE DRAWINGS ARE DEEMED NECESSARY BY THE ENGINEER, THE ENGINEER SHALL NOTE ON THE DRAWINGS THE APPROXIMATE LOCATION AND DESCRIPTION OF THE REPAIRS AND ENTER THE ACTUAL QUANTITIES INTO THE AS-BUILT REPAIR QUANTITY TABLE.

CONTRACTOR SHALL SAW CUT TO A NOMINAL DEPTH OF 1/2" BUT REINFORCING STEEL SHALL NOT BE DAMAGED.

CONTRACTOR SHALL REMOVE SURFACE CONCRETE TO VERIFY THAT SAWCUT DEPTH WILL NOT DAMAGE EXISTING REINFORCING STEEL.

SHOTCRETE REPAIRS MAYBE SUBSTITUTED IN LIEU OF CONCRETE REPAIRS WITH THE APPROVAL OF THE ENGINEER.

FOR UNDERSIDE OF DECK REPAIRS, SEE "OVERHANG, DIAPHRAGM AND BRIDGE RAIL REPAIR DETAILS" SHEET.

FOR SHOTCRETE REPAIRS, SEE SPECIAL PROVISIONS.

FOR CONCRETE REPAIRS, SEE SPECIAL PROVISIONS.

FOR EPOXY RESIN INJECTION, SEE SPECIAL PROVISIONS.



SHOTCRETE REPAIR AREA



CONCRETE REPAIR AREA

PROJECT NO. **I-5950**

**DAVIDSON** COUNTY

BRIDGE NO. **280152**

SHEET 1 OF 3

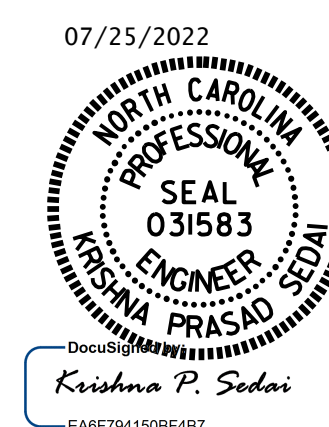

STATE OF NORTH CAROLINA  
DEPARTMENT OF TRANSPORTATION  
RALEIGH

### DECK UNDERSIDE REPAIR SPAN A

#### REVISIONS

NO.	BY:	DATE:	NO.	BY:	DATE:	SHEET NO.
1			3			S5-06
2			4			TOTAL SHEETS 14

DOCUMENT NOT CONSIDERED  
FINAL UNLESS ALL  
SIGNATURES COMPLETED

DRAWN BY : M. G. SHAIKH DATE : 09/2021  
CHECKED BY : E. BAYISSA DATE : 04/2022

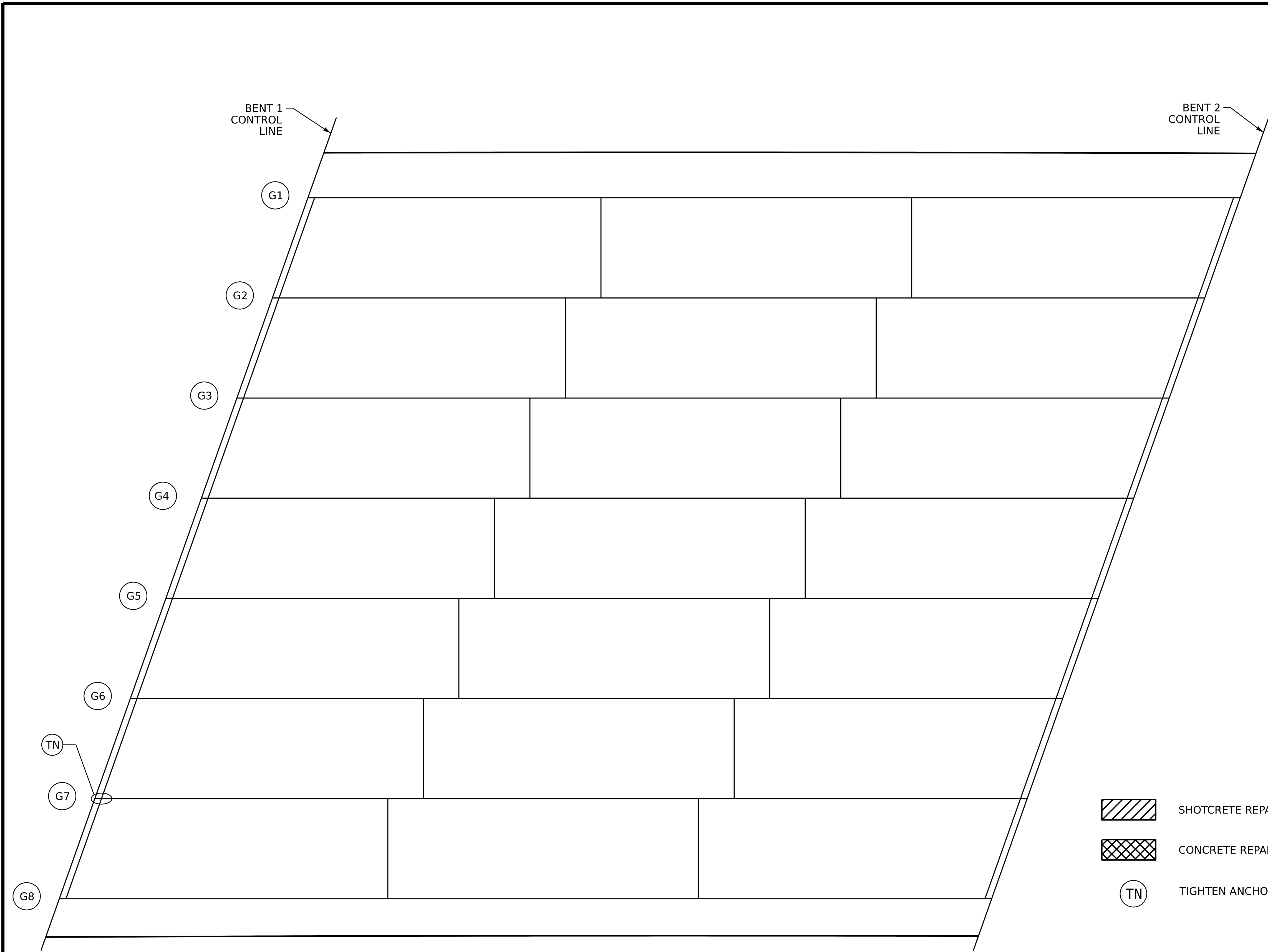

**AS-BUILT REPAIR QUANTITY TABLE**

DECK UNDERSIDE REPAIRS SPAN B	QUANTITIES			
	ESTIMATE		ACTUAL	
SHOTCRETE REPAIRS	AREA SF	VOLUME CF	AREA SF	VOLUME CF
UNDERSIDE OF DECK	0.0	0.0		
CONCRETE DIAPHRAGM	0.0	0.0		
OVERHANG	0.0	0.0		
<b>CONCRETE REPAIRS</b>	<b>AREA SF</b>	<b>VOLUME CF</b>	<b>AREA SF</b>	<b>VOLUME CF</b>
UNDERSIDE OF DECK	0.0	0.0		
CONCRETE DIAPHRAGM	0.0	0.0		
OVERHANG	0.0	0.0		
<b>EPOXY RESIN INJECTION</b>		<b>LIN. FT.</b>		<b>LIN. FT.</b>
UNDERSIDE OF DECK		0.0		
CONCRETE DIAPHRAGM		0.0		
OVERHANG		0.0		

VALUES IN CHART REPRESENT ESTIMATED REPAIR TOTALS AFTER REMOVAL OF UNSOUND CONCRETE, MIN. OF 1" BEHIND REBAR AND MIN. 2" CLEAR TO SAWCUT. SEE REPAIR DETAILS.

**NOTES**

REPAIR LOCATIONS AND ESTIMATE OF QUANTITIES ARE GIVEN BASED ON THE BEST INFORMATION AVAILABLE. IF ADDITIONAL REPAIRS NOT SHOWN ON THE DRAWINGS ARE DEEMED NECESSARY BY THE ENGINEER, THE ENGINEER SHALL NOTE ON THE DRAWINGS THE APPROXIMATE LOCATION AND DESCRIPTION OF THE REPAIRS AND ENTER THE ACTUAL QUANTITIES INTO THE AS-BUILT REPAIR QUANTITY TABLE.

CONTRACTOR SHALL SAW CUT TO A NOMINAL DEPTH OF 1/2" BUT REINFORCING STEEL SHALL NOT BE DAMAGED.

CONTRACTOR SHALL REMOVE SURFACE CONCRETE TO VERIFY THAT SAWCUT DEPTH WILL NOT DAMAGE EXISTING REINFORCING STEEL.

SHOTCRETE REPAIRS MAYBE SUBSTITUTED IN LIEU OF CONCRETE REPAIRS WITH THE APPROVAL OF THE ENGINEER.



FOR UNDERSIDE OF DECK REPAIRS, SEE "OVERHANG, DIAPHRAGM AND BRIDGE RAIL REPAIR DETAILS" SHEET.

PRIOR TO CLEANING AND PAINTING, REPLACE AND /OR TIGHTEN ANCHOR BOLT NUTS. SEE SPECIAL PROVISIONS.

FOR SHOTCRETE REPAIRS, SEE SPECIAL PROVISIONS.

FOR CONCRETE REPAIRS, SEE SPECIAL PROVISIONS.

FOR EPOXY RESIN INJECTION, SEE SPECIAL PROVISIONS.

-  SHOTCRETE REPAIR AREA
-  CONCRETE REPAIR AREA
-  TIGHTEN ANCHOR BOLT NUT

PROJECT NO. **I-5950**  
**DAVIDSON** COUNTY  
 BRIDGE NO. **280152**

SHEET 2 OF 3

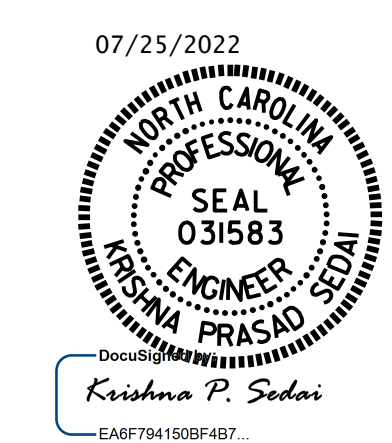

STATE OF NORTH CAROLINA  
 DEPARTMENT OF TRANSPORTATION  
 RALEIGH

**DECK UNDERSIDE REPAIR  
 SPAN B**

DRAWN BY : M. G. SHAIKH DATE : 09/2021  
 CHECKED BY : E. BAYISSA DATE : 03/2022

DOCUMENT NOT CONSIDERED  
 FINAL UNLESS ALL  
 SIGNATURES COMPLETED

REVISIONS						SHEET NO.
NO.	BY:	DATE:	NO.	BY:	DATE:	TOTAL SHEETS
1			3			14
2			4			

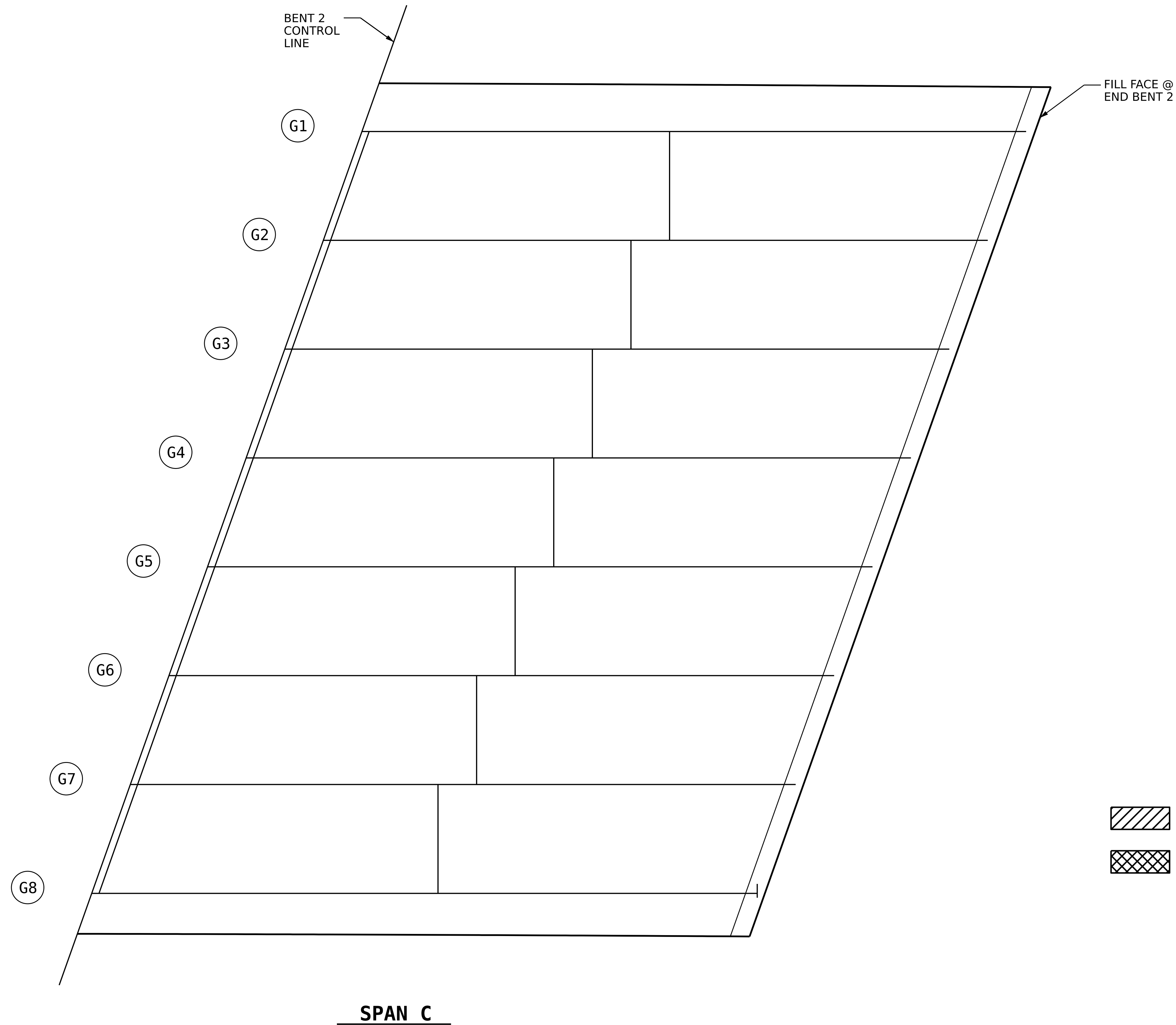

### AS-BUILT REPAIR QUANTITY TABLE

DECK UNDERSIDE REPAIRS SPAN C	QUANTITIES		
	ESTIMATE		
SHOTCRETE REPAIRS	AREA SF	VOLUME CF	AREA SF
UNDERSIDE OF DECK	0.0	0.0	
CONCRETE DIAPHRAGM	0.0	0.0	
OVERHANG	0.0	0.0	
CONCRETE REPAIRS	AREA SF	VOLUME CF	AREA SF
UNDERSIDE OF DECK	0.0	0.0	
CONCRETE DIAPHRAGM	0.0	0.0	
OVERHANG	0.0	0.0	
EPOXY RESIN INJECTION		LIN. FT.	
UNDERSIDE OF DECK		0.0	
CONCRETE DIAPHRAGM		0.0	
OVERHANG		0.0	

VALUES IN CHART REPRESENT ESTIMATED REPAIR TOTALS AFTER REMOVAL OF UNSOUND CONCRETE, MIN. OF 1" BEHIND REBAR AND MIN. 2" CLEAR TO SAWCUT. SEE REPAIR DETAILS.

#### NOTES

REPAIR LOCATIONS AND ESTIMATE OF QUANTITIES ARE GIVEN BASED ON THE BEST INFORMATION AVAILABLE. IF ADDITIONAL REPAIRS NOT SHOWN ON THE DRAWINGS ARE DEEMED NECESSARY BY THE ENGINEER, THE ENGINEER SHALL NOTE ON THE DRAWINGS THE APPROXIMATE LOCATION AND DESCRIPTION OF THE REPAIRS AND ENTER THE ACTUAL QUANTITIES INTO THE AS-BUILT REPAIR QUANTITY TABLE.

CONTRACTOR SHALL SAW CUT TO A NOMINAL DEPTH OF 1/2" BUT REINFORCING STEEL SHALL NOT BE DAMAGED.

CONTRACTOR SHALL REMOVE SURFACE CONCRETE TO VERIFY THAT SAWCUT DEPTH WILL NOT DAMAGE EXISTING REINFORCING STEEL.

SHOTCRETE REPAIRS MAYBE SUBSTITUTED IN LIEU OF CONCRETE REPAIRS WITH THE APPROVAL OF THE ENGINEER.

FOR UNDERSIDE OF DECK REPAIRS, SEE "OVERHANG, DIAPHRAGM AND BRIDGE RAIL REPAIR DETAILS" SHEET.

FOR SHOTCRETE REPAIRS, SEE SPECIAL PROVISIONS.

FOR CONCRETE REPAIRS, SEE SPECIAL PROVISIONS.

FOR EPOXY RESIN INJECTION, SEE SPECIAL PROVISIONS.

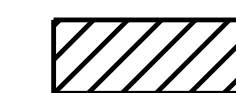

SHOTCRETE REPAIR AREA



CONCRETE REPAIR AREA

PROJECT NO. **I-5950**

**DAVIDSON** COUNTY

BRIDGE NO. **280152**

SHEET 3 OF 3

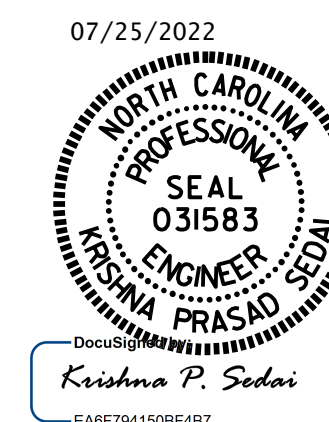

STATE OF NORTH CAROLINA  
DEPARTMENT OF TRANSPORTATION  
RALEIGH

### DECK UNDERSIDE REPAIR SPAN C

#### REVISIONS

NO.	BY:	DATE:	NO.	BY:	DATE:	SHEET NO.
1			3			S5-08
2			4			TOTAL SHEETS 14

DOCUMENT NOT CONSIDERED  
FINAL UNLESS ALL  
SIGNATURES COMPLETED

DRAWN BY : M. G. SHAIKH DATE : 09/2021  
CHECKED BY : E. BAYISSA DATE : 03/2022

### AS-BUILT REPAIR QUANTITY TABLE

REPAIRS - END BENT 1	QUANTITIES			
	ESTIMATE		ACTUAL	
SHOTCRETE REPAIRS	AREA SF	VOLUME CF	AREA SF	VOLUME CF
CAP	0.0	0.0		
CURTAIN WALL	5.0	2.5		
WINGWALL	3.4	1.7		
CONCRETE REPAIRS	AREA SF	VOLUME CF	AREA SF	VOLUME CF
CAP	0	0		
CURTAIN WALL	0	0		
WINGWALL				
EPOXY RESIN INJECTION		LINEAR FT		LINEAR FT
CAP		0		
CURTAIN WALL		0.0		
WINGWALL				
EPOXY COATING		AREA SF		AREA SF
CAP		98.3		
CURTAIN WALL		249.7		

VALUES IN CHART REPRESENT ESTIMATED REPAIR TOTALS AFTER REMOVAL OF UNSOUND CONCRETE, MIN. OF 1" BEHIND REBAR AND MIN. 2" CLEAR TO SAWCUT. SEE REPAIR DETAILS.

#### NOTES

REPAIR LOCATIONS AND ESTIMATE OF QUANTITIES ARE GIVEN BASED ON THE BEST INFORMATION AVAILABLE. IF ADDITIONAL REPAIRS NOT SHOWN ON THE DRAWINGS ARE DEEMED NECESSARY BY THE ENGINEER, THE ENGINEER SHALL NOTE ON THE DRAWINGS THE APPROXIMATE LOCATION AND DESCRIPTION OF THE REPAIRS AND ENTER THE ACTUAL QUANTITIES INTO THE AS-BUILT REPAIR QUANTITY TABLE.

CLEAN AND REMOVE DEBRIS FROM THE TOP OF THE CAP AND APPLY EPOXY PROTECTIVE COATING. EPOXY COATING SHALL BE APPLIED TO THE TOP SURFACE OF THE CAP. THE CONTRACTOR SHALL NOT COAT THE AREA OF THE CAP BENEATH THE MASONRY PLATES. FOR EPOXY COATING, SEE SPECIAL PROVISIONS.

SHOTCRETE REPAIRS MAYBE SUBSTITUTED IN LIEU OF CONCRETE REPAIRS WITH THE APPROVAL OF THE ENGINEER.

FOR CAP AND COLUMN REPAIRS, SEE "TYPICAL CAP AND COLUMN REPAIR DETAILS" SHEET.

FOR SHOTCRETE REPAIRS, SEE SPECIAL PROVISIONS.

FOR CONCRETE REPAIRS, SEE SPECIAL PROVISIONS.

FOR EPOXY RESIN INJECTION, SEE SPECIAL PROVISIONS.

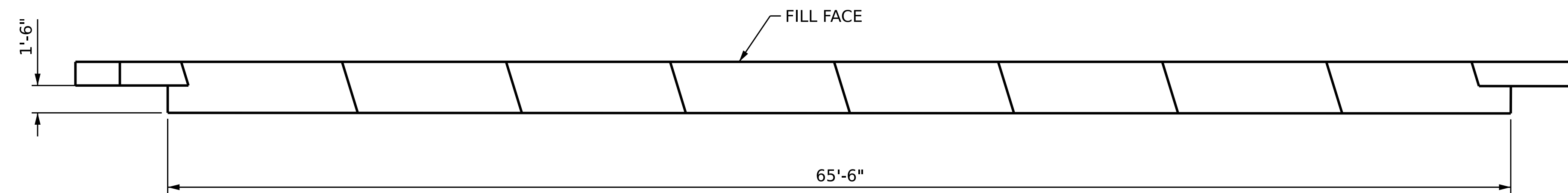

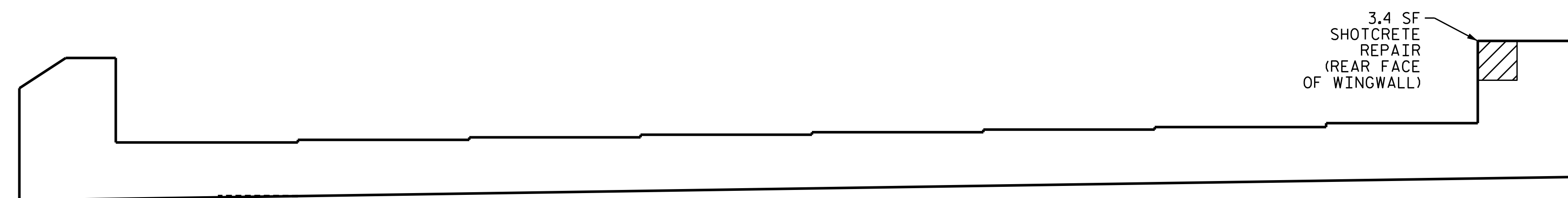

**PLAN**

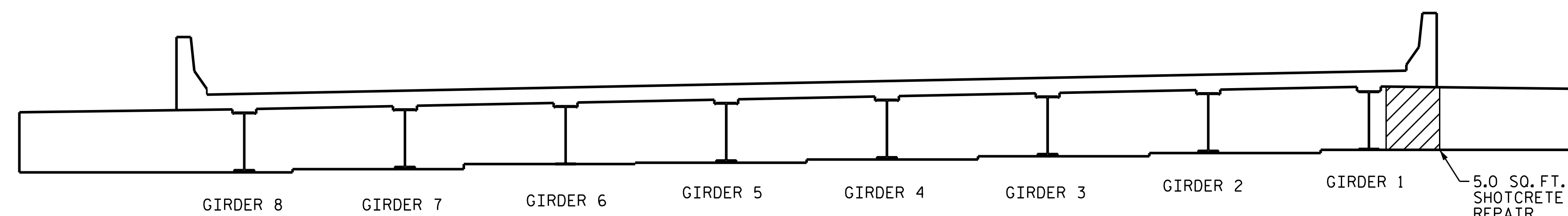

**ELEVATION**

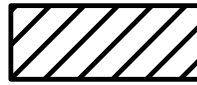

**TYPICAL SECTION**

-  SHOTCRETE REPAIR AREA
-  CONCRETE REPAIR AREA
-  EPOXY RESIN INJECTION

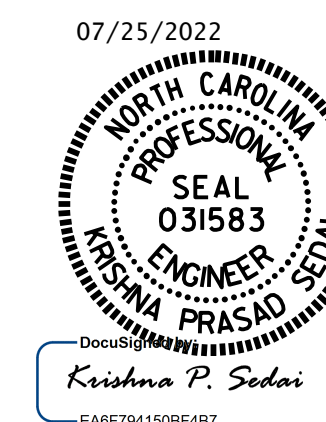

PROJECT NO. **I-5950**  
**DAVIDSON** COUNTY  
 BRIDGE NO. **280152**

STATE OF NORTH CAROLINA  
 DEPARTMENT OF TRANSPORTATION  
 RALEIGH

**SUBSTRUCTURE REPAIR  
 END BENT 1**

DRAWN BY : **M. G. SHAIKH** DATE : **09/2020**  
 CHECKED BY : **E. BAYISSA** DATE : **03/2022**  
 DESIGN ENGINEER OF RECORD: \_\_\_\_\_ DATE : \_\_\_\_\_

DOCUMENT NOT CONSIDERED  
 FINAL UNLESS ALL  
 SIGNATURES COMPLETED

REVISIONS						SHEET NO. 55-09
NO.	BY:	DATE:	NO.	BY:	DATE:	
1			3			TOTAL SHEETS 14
2			4			

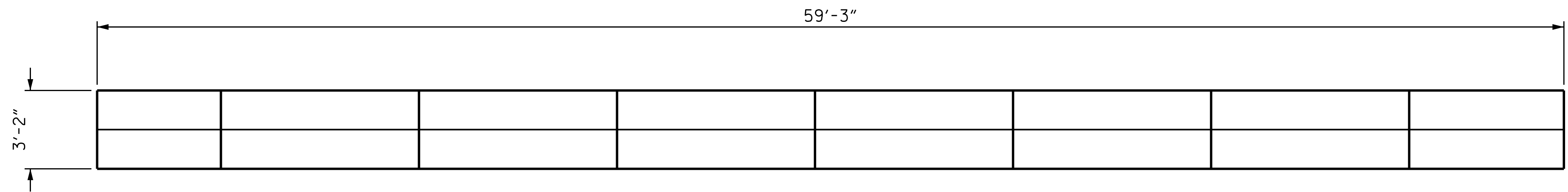

**PLAN - TOP OF CAP**

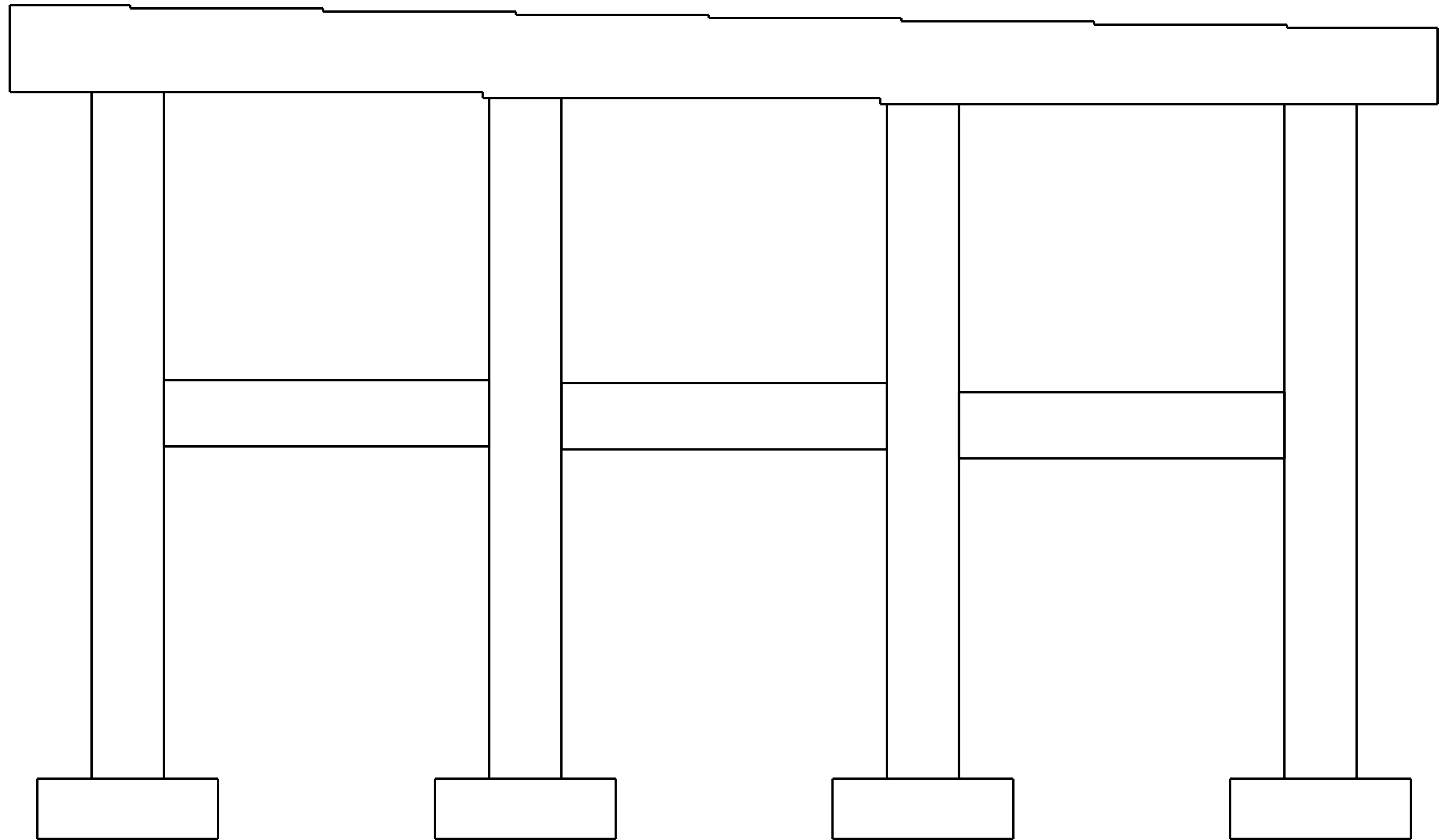

**ELEVATION**

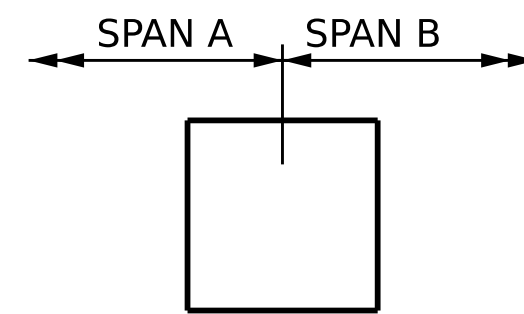

**END VIEW**

- CONCRETE REPAIR AREA
- SHOTCRETE REPAIR AREA
- EPOXY RESIN INJECTION (ERI)

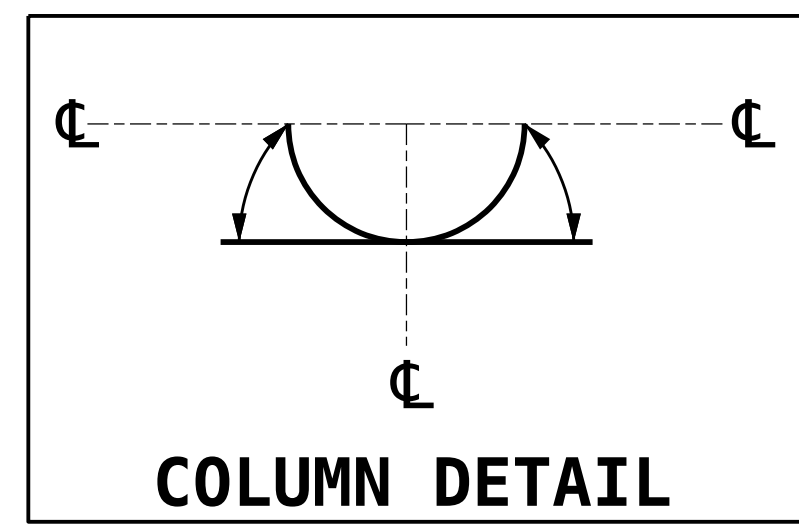

**COLUMN DETAIL**

AS-BUILT REPAIR QUANTITY TABLE				
BENT 1 SPAN A FACE	QUANTITIES			
	ESTIMATE		ACTUAL	
SHOTCRETE REPAIRS	AREA SQ. FT.	VOLUME CU. FT.	AREA SQ. FT.	VOLUME CU. FT.
CAP	0.0	0.0		
COLUMN	0.0	0.0		
CONCRETE REPAIRS	AREA SQ. FT.	VOLUME CU. FT.	AREA SQ. FT.	VOLUME CU. FT.
CAP	0.0	0.0		
COLUMN	0.0	0.0		
EPOXY RESIN INJECTION	LIN. FT.		LIN. FT.	
CAP	0.0			
COLUMN	0.0			
EPOXY COATING	SQ. FT.		SQ. FT.	
TOP OF BENT CAP	187.6			
TOP OF STRUT	111.4			

VALUES IN CHART REPRESENT ESTIMATED REPAIR TOTALS AFTER REMOVAL OF UNSOUND CONCRETE, MINIMUM OF 1" BEHIND REBAR AND MINIMUM OF 2" CLEARANCE TO SAWCUT. FOR REPAIR DETAILS, SEE "TYPICAL CAP AND COLUMN REPAIR DETAILS" SHEET.

**NOTES:**

REPAIR LOCATIONS AND ESTIMATE OF QUANTITIES ARE BASED ON THE BEST INFORMATION AVAILABLE. IF ADDITIONAL REPAIRS NOT SHOWN ON THE DRAWINGS ARE DEEMED NECESSARY BY THE ENGINEER, THE ENGINEER WILL NOTE ON THE DRAWINGS THE APPROXIMATE LOCATIONS AND DESCRIPTION OF THE REPAIRS AND ENTER THE ACTUAL QUANTITIES INTO THE AS-BUILT REPAIR QUANTITY TABLE.

CLEAN AND REMOVE DEBRIS FROM THE TOP OF THE CAP AND APPLY EPOXY PROTECTIVE COATING. EPOXY COATING SHALL BE APPLIED TO THE TOP SURFACE OF THE CAP. THE CONTRACTOR SHALL NOT COAT THE AREA OF THE CAP BENEATH THE MASONRY PLATES. FOR EPOXY COATING, SEE SPECIAL PROVISIONS.

SHOTCRETE REPAIRS MAY BE REPLACED WITH CONCRETE REPAIRS WITH THE APPROVAL OF THE ENGINEER.

FOR CAP AND COLUMN REPAIR DETAILS, SEE "TYPICAL CAP AND COLUMN REPAIR DETAILS" SHEET.

FOR SHOTCRETE REPAIRS, SEE SPECIAL PROVISIONS.

FOR CONCRETE REPAIRS, SEE SPECIAL PROVISIONS.

FOR EPOXY RESIN INJECTION, SEE SPECIAL PROVISIONS.

PROJECT NO. **I-5950**  
**DAVIDSON** COUNTY  
 BRIDGE NO. **280152**

SHEET 1 OF 2

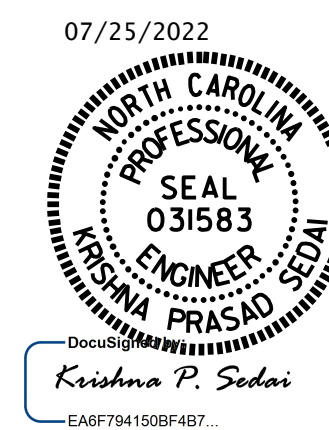

STATE OF NORTH CAROLINA  
 DEPARTMENT OF TRANSPORTATION  
 RALEIGH

**SUBSTRUCTURE REPAIR  
 BENT 1  
 SPAN A FACE**

DRAWN BY : **M. G. SHAIKH** DATE : **09/2021**  
 CHECKED BY : **E. BAYISSA** DATE : **03/2022**  
 DESIGN ENGINEER OF RECORD: \_\_\_\_\_ DATE : \_\_\_\_\_

DOCUMENT NOT CONSIDERED FINAL UNLESS ALL SIGNATURES COMPLETED

REVISIONS						SHEET NO.
NO.	BY:	DATE:	NO.	BY:	DATE:	S5-10
1			3			TOTAL SHEETS
2			4			14



SPAN B  
SPAN A

**PLAN - BOTTOM OF CAP**

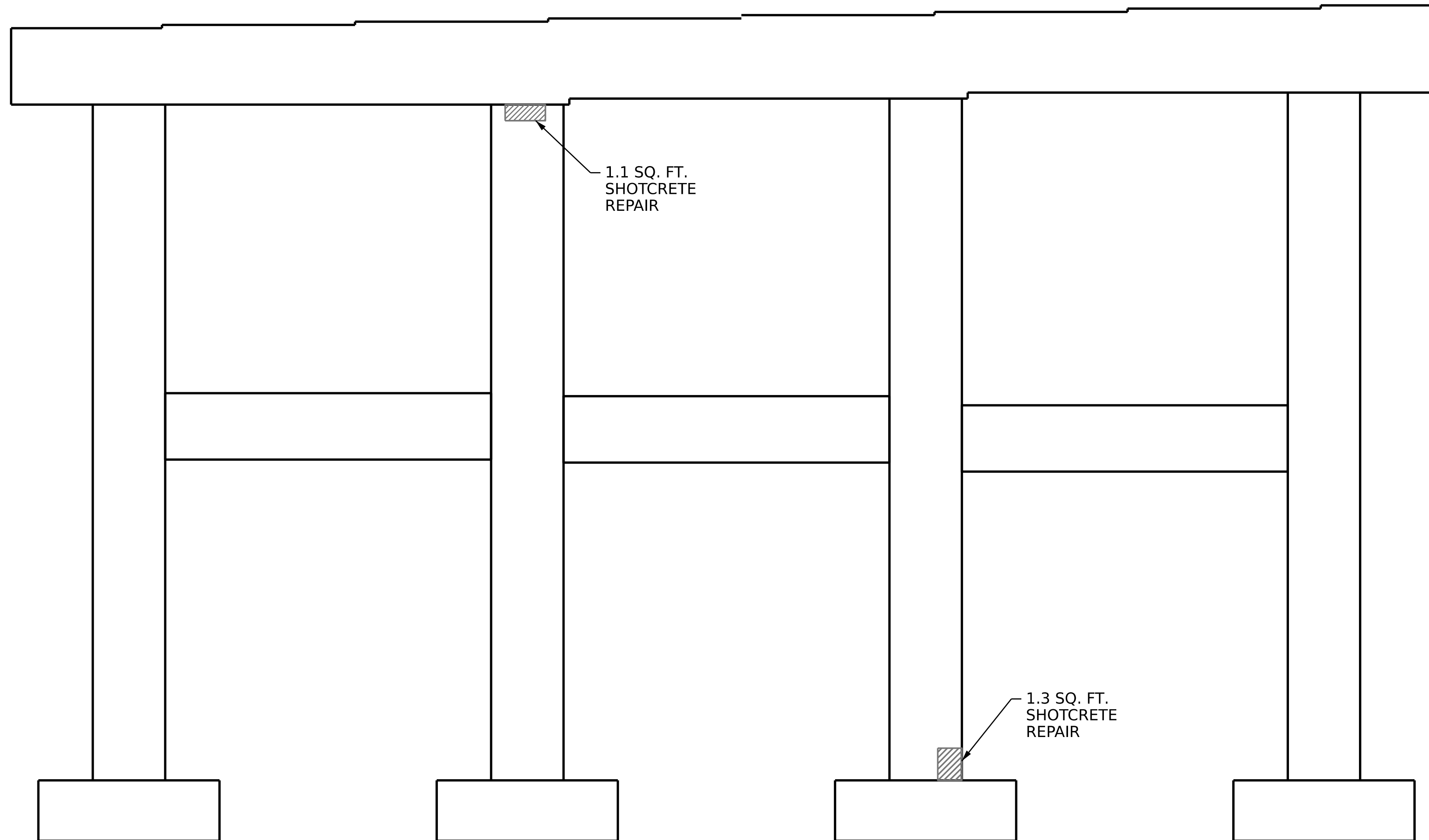

1.1 SQ. FT.  
SHOTCRETE  
REPAIR

1.3 SQ. FT.  
SHOTCRETE  
REPAIR

**ELEVATION**

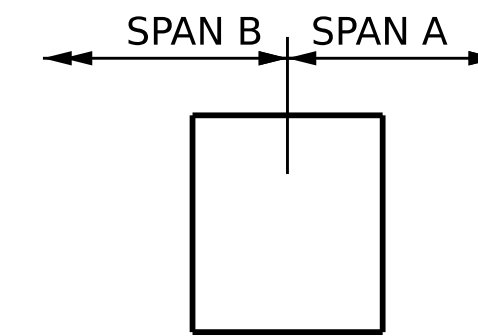

**END VIEW**

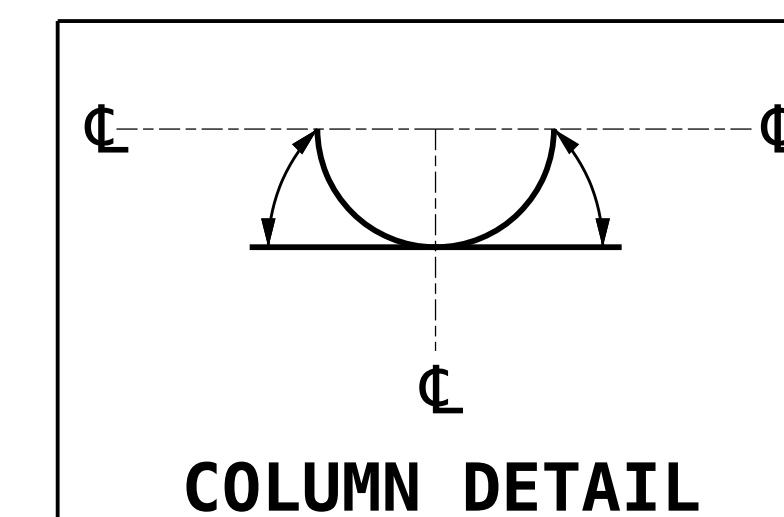

**COLUMN DETAIL**

**AS-BUILT REPAIR QUANTITY TABLE**

BENT 1 SPAN B FACE	QUANTITIES			
	ESTIMATE		ACTUAL	
SHOTCRETE REPAIRS	AREA SQ. FT.	VOLUME CU. FT.	AREA SQ. FT.	VOLUME CU. FT.
CAP	0.0	0.0		
COLUMN	2.4	1.2		
CONCRETE REPAIRS	AREA SQ. FT.	VOLUME CU. FT.	AREA SQ. FT.	VOLUME CU. FT.
CAP	0.0	0.0		
COLUMN	0.0	0.0		
EPOXY RESIN INJECTION		LIN. FT.		LIN. FT.
CAP		0.0		
COLUMN		0.0		

VALUES IN CHART REPRESENT ESTIMATED REPAIR TOTALS AFTER REMOVAL OF UNSOUND CONCRETE, MINIMUM OF 1" BEHIND REBAR AND MINIMUM OF 2" CLEARANCE TO SAWCUT.

**NOTES:**

REPAIR LOCATIONS AND ESTIMATE OF QUANTITIES ARE BASED ON THE BEST INFORMATION AVAILABLE. IF ADDITIONAL REPAIRS NOT SHOWN ON THE DRAWINGS ARE DEEMED NECESSARY BY THE ENGINEER, THE ENGINEER WILL NOTE ON THE DRAWINGS THE APPROXIMATE LOCATIONS AND DESCRIPTION OF THE REPAIRS AND ENTER THE ACTUAL QUANTITIES INTO THE AS-BUILT REPAIR QUANTITY TABLE.



SHOTCRETE REPAIRS MAY BE REPLACED WITH CONCRETE REPAIRS WITH THE APPROVAL OF THE ENGINEER.

FOR CAP AND COLUMN REPAIR DETAILS, SEE "TYPICAL CAP AND COLUMN REPAIR DETAILS" SHEET.

FOR SHOTCRETE REPAIRS, SEE SPECIAL PROVISIONS.

FOR CONCRETE REPAIRS, SEE SPECIAL PROVISIONS.

FOR EPOXY RESIN INJECTION, SEE SPECIAL PROVISIONS.

-  CONCRETE REPAIR AREA
-  SHOTCRETE REPAIR AREA
-  EPOXY RESIN INJECTION (ERI)

PROJECT NO. **I-5950**  
**DAVIDSON** COUNTY  
 BRIDGE NO. **280152**

SHEET 2 OF 2

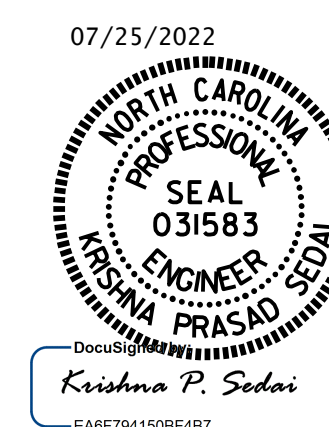

STATE OF NORTH CAROLINA  
 DEPARTMENT OF TRANSPORTATION  
 RALEIGH

**SUBSTRUCTURE REPAIR  
 BENT 1  
 SPAN B FACE**

REVISIONS						SHEET NO.
NO.	BY:	DATE:	NO.	BY:	DATE:	S5-11
1			3			TOTAL SHEETS
2			4			14

DOCUMENT NOT CONSIDERED FINAL UNLESS ALL SIGNATURES COMPLETED

DRAWN BY : **M. G. SHAIKH** DATE : **09/2021**  
 CHECKED BY : **E. BAYISSA** DATE : **03/2022**  
 DESIGN ENGINEER OF RECORD: \_\_\_\_\_ DATE : \_\_\_\_\_



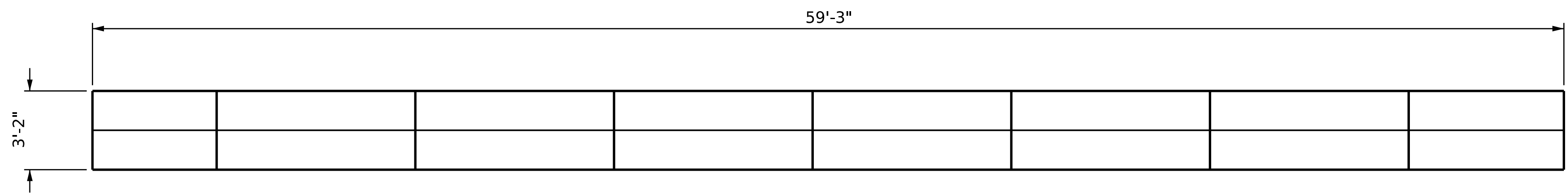

**PLAN - TOP OF CAP**

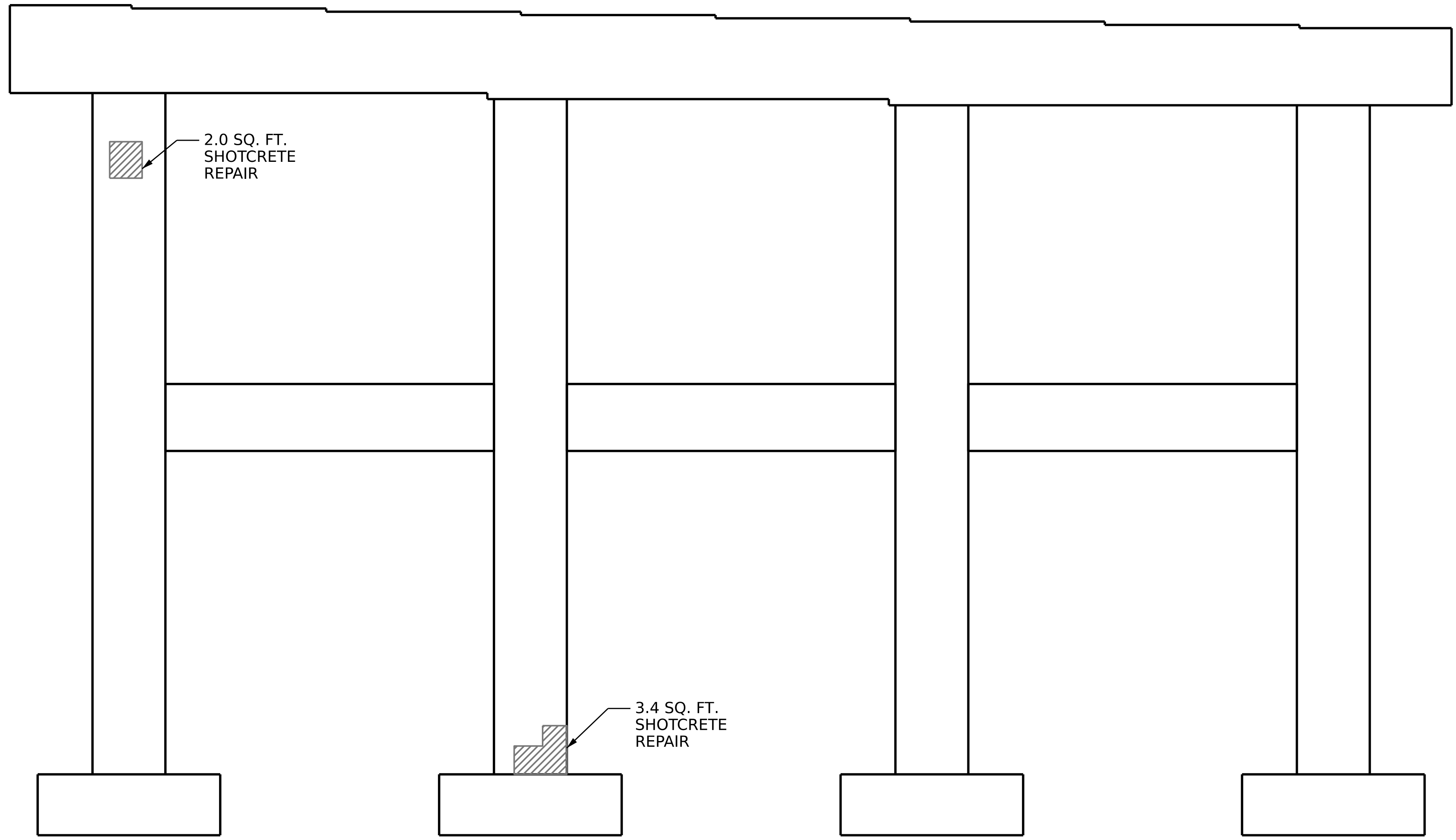

**ELEVATION**

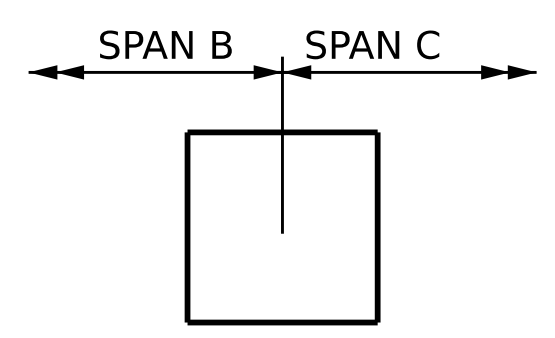

**END VIEW**

- CONCRETE REPAIR AREA
- SHOTCRETE REPAIR AREA
- EPOXY RESIN INJECTION (ERI)

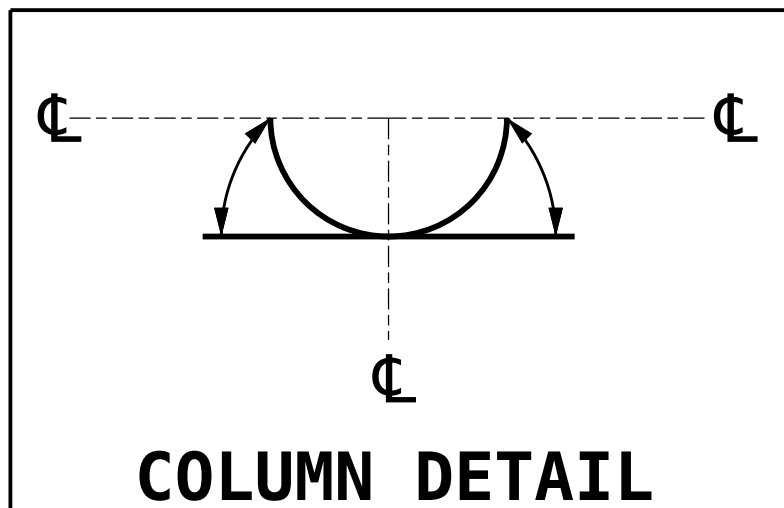

**COLUMN DETAIL**

AS-BUILT REPAIR QUANTITY TABLE				
BENT 2 SPAN B FACE	QUANTITIES			
	ESTIMATE		ACTUAL	
SHOTCRETE REPAIRS	AREA SQ. FT.	VOLUME CU. FT.	AREA SQ. FT.	VOLUME CU. FT.
CAP	0.0	0.0		
COLUMN	5.4	2.7		
CONCRETE REPAIRS	AREA SQ. FT.	VOLUME CU. FT.	AREA SQ. FT.	VOLUME CU. FT.
CAP	0.0	0.0		
COLUMN	0.0	0.0		
EPOXY RESIN INJECTION	LIN. FT.		LIN. FT.	
CAP	0.0			
COLUMN	0.0			
EPOXY COATING	SQ. FT.		SQ. FT.	
TOP OF BENT CAP	187.6			
TOP OF STRUT	111.4			

VALUES IN CHART REPRESENT ESTIMATED REPAIR TOTALS AFTER REMOVAL OF UNSOUND CONCRETE, MINIMUM OF 1" BEHIND REBAR AND MINIMUM OF 2" CLEARANCE TO SAWCUT. FOR REPAIR DETAILS, SEE "TYPICAL CAP AND COLUMN REPAIR DETAILS" SHEET.

**NOTES:**  
 REPAIR LOCATIONS AND ESTIMATE OF QUANTITIES ARE BASED ON THE BEST INFORMATION AVAILABLE. IF ADDITIONAL REPAIRS NOT SHOWN ON THE DRAWINGS ARE DEEMED NECESSARY BY THE ENGINEER, THE ENGINEER WILL NOTE ON THE DRAWINGS THE APPROXIMATE LOCATIONS AND DESCRIPTION OF THE REPAIRS AND ENTER THE ACTUAL QUANTITIES INTO THE AS-BUILT REPAIR QUANTITY TABLE.

CLEAN AND REMOVE DEBRIS FROM THE TOP OF THE CAP AND APPLY EPOXY PROTECTIVE COATING. EPOXY COATING SHALL BE APPLIED TO THE TOP SURFACE OF THE CAP. THE CONTRACTOR SHALL NOT COAT THE AREA OF THE CAP BENEATH THE MASONRY PLATES. FOR EPOXY COATING, SEE SPECIAL PROVISIONS.

SHOTCRETE REPAIRS MAY BE REPLACED WITH CONCRETE REPAIRS WITH THE APPROVAL OF THE ENGINEER.

FOR CAP AND COLUMN REPAIR DETAILS, SEE "TYPICAL CAP AND COLUMN REPAIR DETAILS" SHEET.

FOR SHOTCRETE REPAIRS, SEE SPECIAL PROVISIONS.

FOR CONCRETE REPAIRS, SEE SPECIAL PROVISIONS.

FOR EPOXY RESIN INJECTION, SEE SPECIAL PROVISIONS.

PROJECT NO. **I-5950**  
**DAVIDSON** COUNTY  
 BRIDGE NO. **280152**

SHEET 1 OF 2

STATE OF NORTH CAROLINA  
 DEPARTMENT OF TRANSPORTATION  
 RALEIGH

**SUBSTRUCTURE REPAIR  
 BENT 2  
 SPAN B FACE**

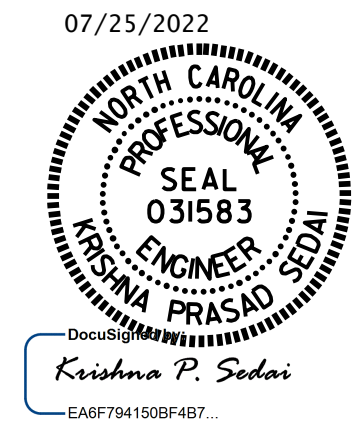

DRAWN BY : **M. G. SHAIKH** DATE : **09/2021**  
 CHECKED BY : **E. BAYISSA** DATE : **03/2022**  
 DESIGN ENGINEER OF RECORD: \_\_\_\_\_ DATE : \_\_\_\_\_

REVISIONS					SHEET NO.
NO.	BY:	DATE:	NO.	BY:	DATE:
1			3		
2			4		

DOCUMENT NOT CONSIDERED FINAL UNLESS ALL SIGNATURES COMPLETED

TOTAL SHEETS	14
--------------	----

AS-BUILT REPAIR QUANTITY TABLE				
BENT 2 SPAN C FACE	QUANTITIES			
	ESTIMATE		ACTUAL	
SHOTCRETE REPAIRS	AREA SQ. FT.	VOLUME CU. FT.	AREA SQ. FT.	VOLUME CU. FT.
CAP	0.0	0.0		
COLUMN	0.0	0.0		
CONCRETE REPAIRS	AREA SQ. FT.	VOLUME CU. FT.	AREA SQ. FT.	VOLUME CU. FT.
CAP	0.0	0.0		
COLUMN	0.0	0.0		
EPOXY RESIN INJECTION		LIN. FT.		LIN. FT.
CAP		0.0		
COLUMN		0.0		

VALUES IN CHART REPRESENT ESTIMATED REPAIR TOTALS AFTER REMOVAL OF UNSOUND CONCRETE, MINIMUM OF 1" BEHIND REBAR AND MINIMUM OF 2" CLEARANCE TO SAWCUT.

**NOTES:**  
 REPAIR LOCATIONS AND ESTIMATE OF QUANTITIES ARE BASED ON THE BEST INFORMATION AVAILABLE. IF ADDITIONAL REPAIRS NOT SHOWN ON THE DRAWINGS ARE DEEMED NECESSARY BY THE ENGINEER, THE ENGINEER WILL NOTE ON THE DRAWINGS THE APPROXIMATE LOCATIONS AND DESCRIPTION OF THE REPAIRS AND ENTER THE ACTUAL QUANTITIES INTO THE AS-BUILT REPAIR QUANTITY TABLE.  
 SHOTCRETE REPAIRS MAY BE REPLACED WITH CONCRETE REPAIRS WITH THE APPROVAL OF THE ENGINEER.  
 FOR CAP AND COLUMN REPAIR DETAILS, SEE "TYPICAL CAP AND COLUMN REPAIR DETAILS" SHEET.  
 FOR SHOTCRETE REPAIRS, SEE SPECIAL PROVISIONS.  
 FOR CONCRETE REPAIRS, SEE SPECIAL PROVISIONS.  
 FOR EPOXY RESIN INJECTION, SEE SPECIAL PROVISIONS.

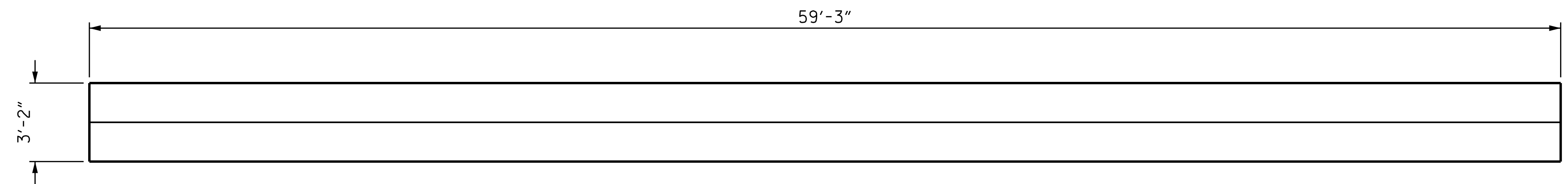

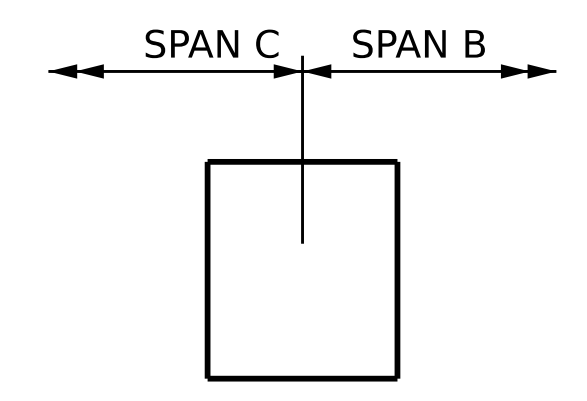

**PLAN - BOTTOM OF CAP**

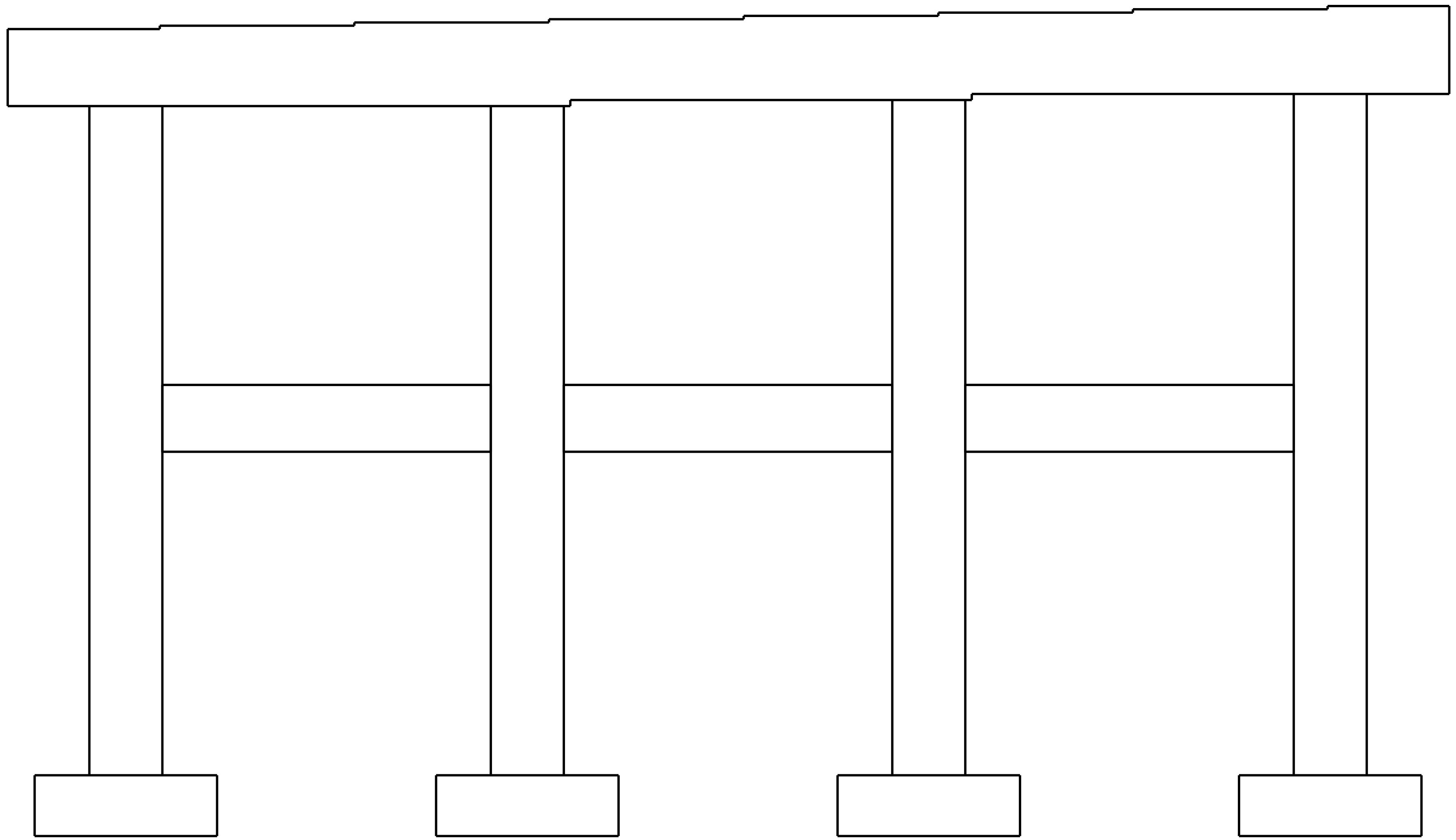

**END VIEW**

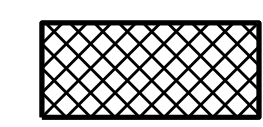
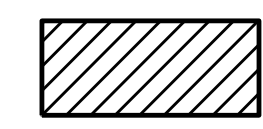

**ELEVATION**

-  CONCRETE REPAIR AREA
-  SHOTCRETE REPAIR AREA
-  EPOXY RESIN INJECTION (ERI)

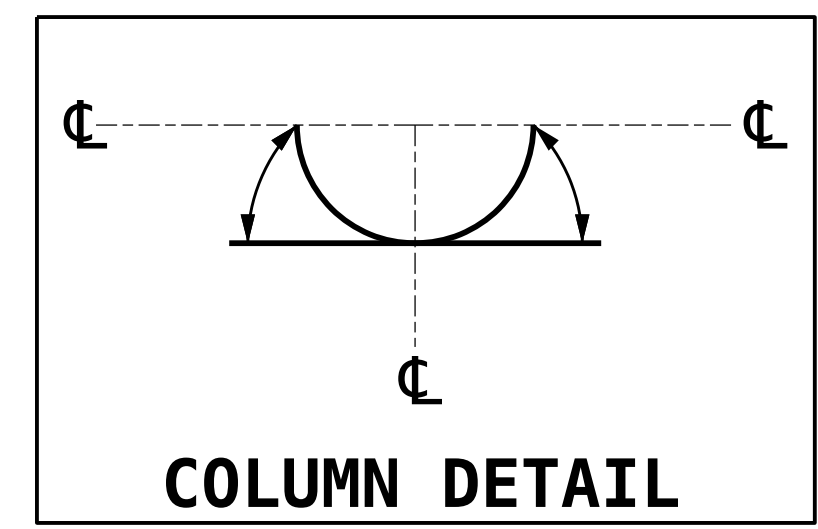

**COLUMN DETAIL**

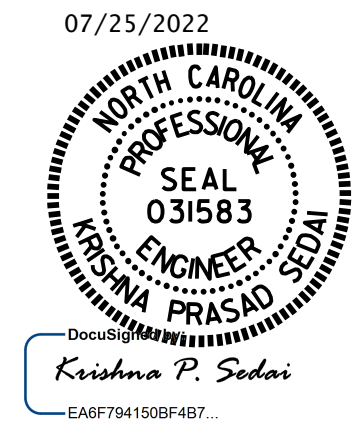

PROJECT NO. I-5950  
DAVIDSON COUNTY  
 BRIDGE NO. 280152

SHEET 2 OF 2

STATE OF NORTH CAROLINA  
 DEPARTMENT OF TRANSPORTATION  
 RALEIGH

**SUBSTRUCTURE REPAIR  
 BENT 2  
 SPAN C FACE**

DRAWN BY : M. G. SHAIKH DATE : 09/2021  
 CHECKED BY : E. BAYISSA DATE : 03/2022  
 DESIGN ENGINEER OF RECORD: \_\_\_\_\_ DATE : \_\_\_\_\_

REVISIONS						SHEET NO.
NO.	BY:	DATE:	NO.	BY:	DATE:	S5-13
1			3			TOTAL SHEETS
2			4			14

DOCUMENT NOT CONSIDERED FINAL UNLESS ALL SIGNATURES COMPLETED

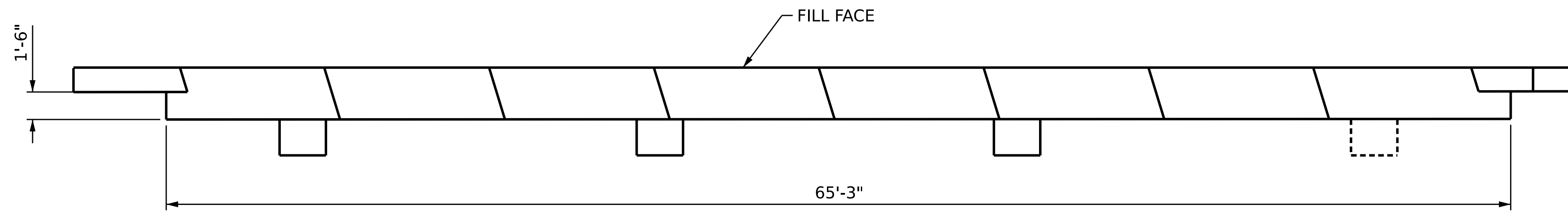



**PLAN**

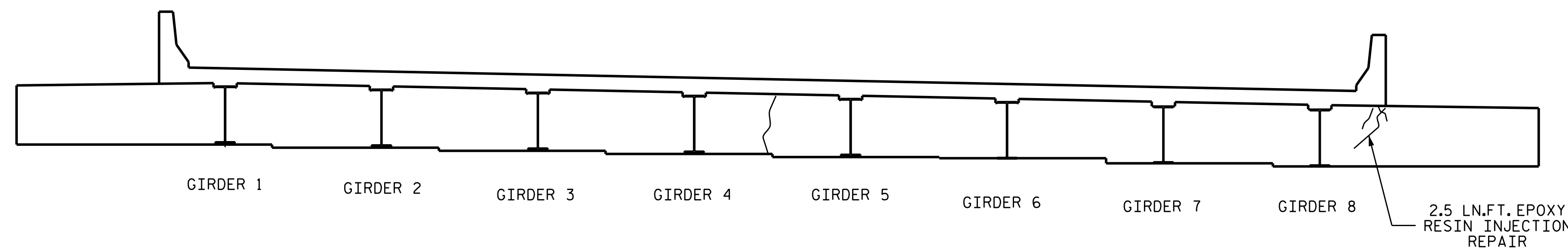

**ELEVATION**

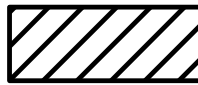

**TYPICAL SECTION**

-  SHOTCRETE REPAIR AREA
-  CONCRETE REPAIR AREA
-  EPOXY RESIN INJECTION

AS-BUILT REPAIR QUANTITY TABLE				
REPAIRS - END BENT 2	QUANTITIES			
	ESTIMATE		ACTUAL	
SHOTCRETE REPAIRS	AREA SF	VOLUME CF	AREA SF	VOLUME CF
CAP	0.8	0.4		
CURTAIN WALL	0.0	0.0		
WINGWALL	0.0	0.0		
CONCRETE REPAIRS	AREA SF	VOLUME CF	AREA SF	VOLUME CF
CAP	0	0		
CURTAIN WALL	0	0		
WINGWALL				
EPOXY RESIN INJECTION		LINEAR FT		LINEAR FT
CAP		0		
CURTAIN WALL		2.5		
WINGWALL				
EPOXY COATING		AREA SF		AREA SF
CAP		97.9		
CURTAIN WALL		249.7		

VALUES IN CHART REPRESENT ESTIMATED REPAIR TOTALS AFTER REMOVAL OF UNSOUND CONCRETE, MIN. OF 1" BEHIND REBAR AND MIN. 2" CLEAR TO SAWCUT. SEE REPAIR DETAILS.

**NOTES**

REPAIR LOCATIONS AND ESTIMATE OF QUANTITIES ARE GIVEN BASED ON THE BEST INFORMATION AVAILABLE. IF ADDITIONAL REPAIRS NOT SHOWN ON THE DRAWINGS ARE DEEMED NECESSARY BY THE ENGINEER, THE ENGINEER SHALL NOTE ON THE DRAWINGS THE APPROXIMATE LOCATION AND DESCRIPTION OF THE REPAIRS AND ENTER THE ACTUAL QUANTITIES INTO THE AS-BUILT REPAIR QUANTITY TABLE.

CLEAN AND REMOVE DEBRIS FROM THE TOP OF THE CAP AND APPLY EPOXY PROTECTIVE COATING. EPOXY COATING SHALL BE APPLIED TO THE TOP SURFACE OF THE CAP. THE CONTRACTOR SHALL NOT COAT THE AREA OF THE CAP BENEATH THE MASONRY PLATES. FOR EPOXY COATING, SEE SPECIAL PROVISIONS.

SHOTCRETE REPAIRS MAYBE SUBSTITUTED IN LIEU OF CONCRETE REPAIRS WITH THE APPROVAL OF THE ENGINEER.

FOR CAP AND COLUMN REPAIRS, SEE "TYPICAL CAP AND COLUMN REPAIR DETAILS" SHEET.

FOR SHOTCRETE REPAIRS, SEE SPECIAL PROVISIONS.

FOR CONCRETE REPAIRS, SEE SPECIAL PROVISIONS.

FOR EPOXY RESIN INJECTION, SEE SPECIAL PROVISIONS.

PROJECT NO. **I-5950**  
**DAVIDSON** COUNTY  
 BRIDGE NO. **280152**

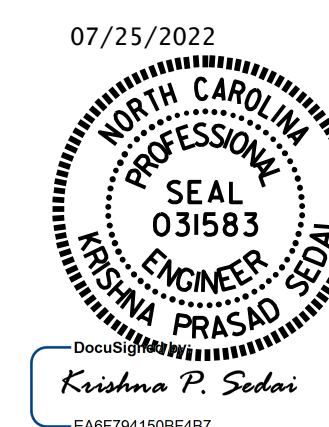

STATE OF NORTH CAROLINA  
 DEPARTMENT OF TRANSPORTATION  
 RALEIGH  
**SUBSTRUCTURE REPAIR  
 END BENT 2**

DRAWN BY : **M. G. SHAIKH** DATE : **09/2020**  
 CHECKED BY : **A. SORSENGINH** DATE : **09/2020**  
 DESIGN ENGINEER OF RECORD: \_\_\_\_\_ DATE : \_\_\_\_\_

DOCUMENT NOT CONSIDERED  
 FINAL UNLESS ALL  
 SIGNATURES COMPLETED

REVISIONS						SHEET NO. S5-14
NO.	BY:	DATE:	NO.	BY:	DATE:	
1			3			TOTAL SHEETS 14
2			4			

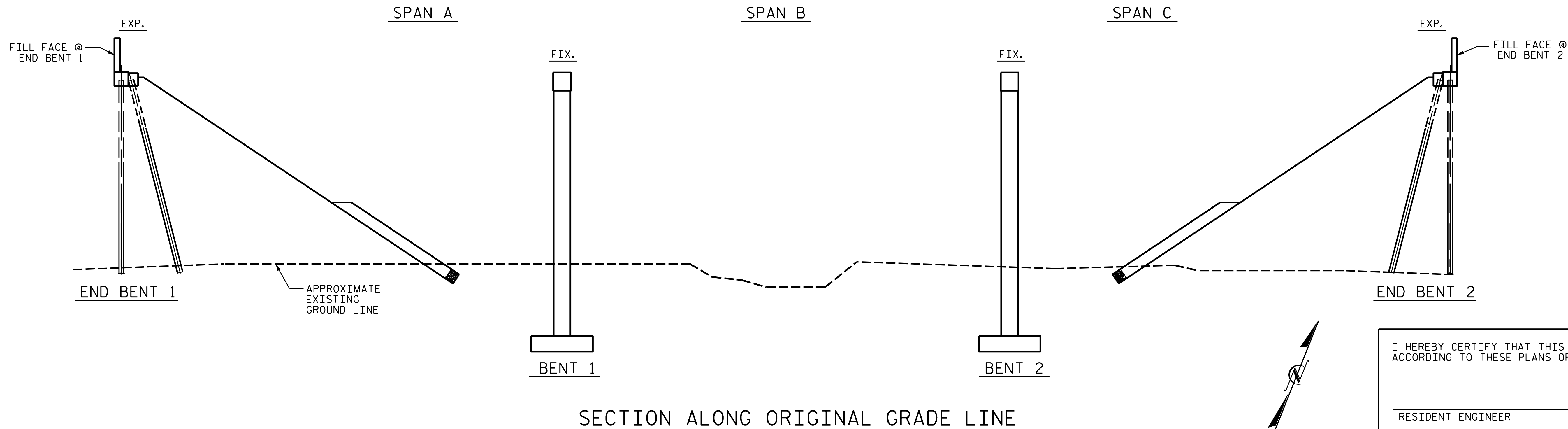

**NOTES**  
 GENERAL DRAWING INFORMATION IS TAKEN FROM THE ORIGINAL PLANS AND THE ROUTINE INSPECTION REPORT DATED 05/12/2020.  
 BRIDGE ORIENTATION CONFORMS TO THE EXISTING BRIDGE PLANS/ ROUTINE INSPECTION.

I HEREBY CERTIFY THAT THIS STRUCTURE WAS REHABILITATED ACCORDING TO THESE PLANS OR AS NOTED HEREIN.  
 RESIDENT ENGINEER \_\_\_\_\_ DATE \_\_\_\_\_

SECTION ALONG ORIGINAL GRADE LINE

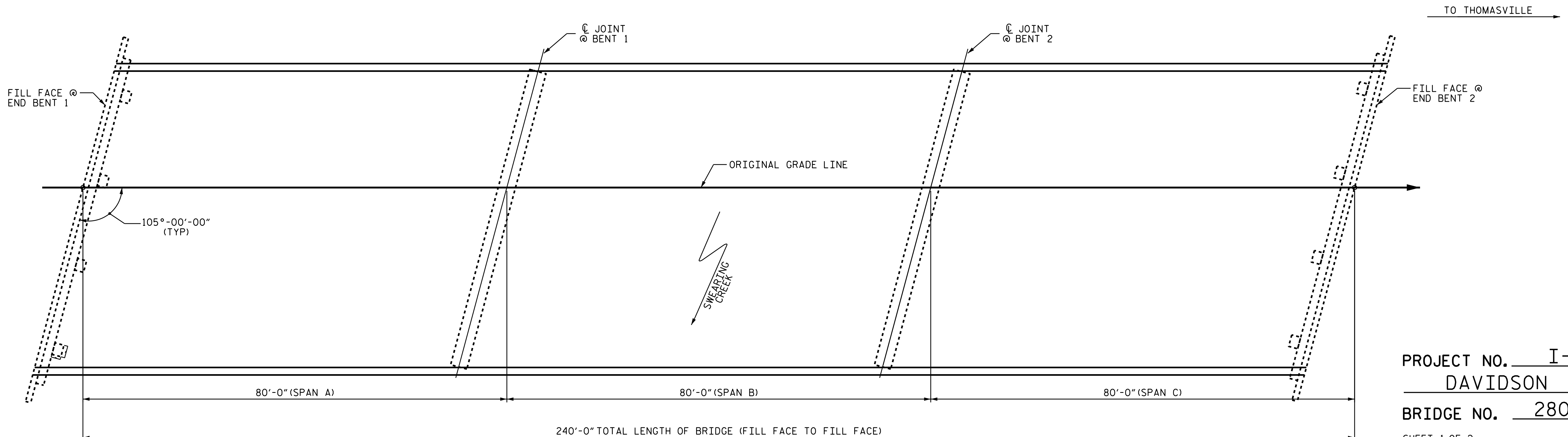

PLAN

**SCOPE OF WORK**

- PARTIALLY REMOVE TOP OF BRIDGE DECK CONCRETE BY SCARIFICATION AND SHOTBLASTING METHODS.
- OVERLAY PREPARED TOP OF BRIDGE DECK WITH POLYMER CONCRETE (PC).
- REMOVE EXISTING JOINT MATERIAL AND INSTALL FOAM JOINT SEALS FOR PRESERVATION.
- GROOVE PC BRIDGE DECK.
- EPOXY RESIN INJECTION OF CONCRETE CRACKS.
- REMOVE DEBRIS FROM TOP OF EXISTING END BENT CAPS AND APPLY EPOXY COATING.
- PROPERLY PREPARE SPALLED AREAS IN EXISTING END BENTS AND BENTS, AND PERFORM SHOTCRETE AND CONCRETE REPAIRS.
- CLEAN AND PAINT EXISTING BEARINGS AT END BENT.
- PLACE GEOTEXTILE AND RIP RAP.

DRAWN BY : S. AGUILAR HERNANDEZ DATE : 07/2020  
 CHECKED BY : E. BAYISSA DATE : 04/2022

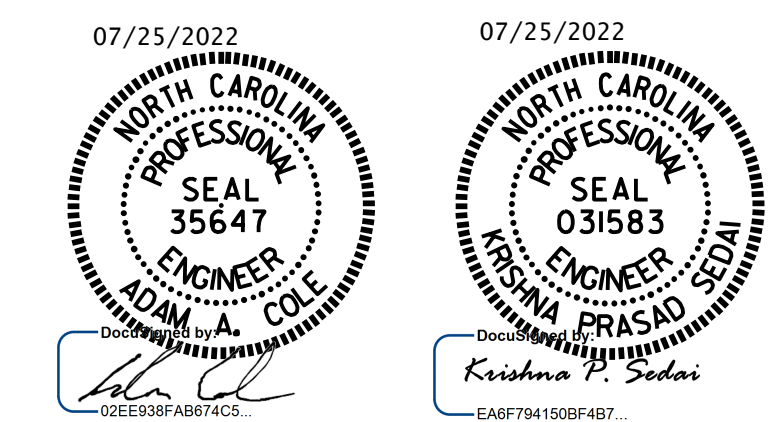

PROJECT NO. I-5950  
 DAVIDSON COUNTY  
 BRIDGE NO. 280154

SHEET 1 OF 2

STATE OF NORTH CAROLINA  
 DEPARTMENT OF TRANSPORTATION  
 RALEIGH

GENERAL DRAWING  
 FOR BRIDGE ON I-85N  
 OVER SWEARING CREEK

REVISIONS						SHEET NO.
NO.	BY:	DATE:	NO.	BY:	DATE:	S6-01
1			3			TOTAL SHEETS
2			4			15

DOCUMENT NOT CONSIDERED FINAL UNLESS ALL SIGNATURES COMPLETED

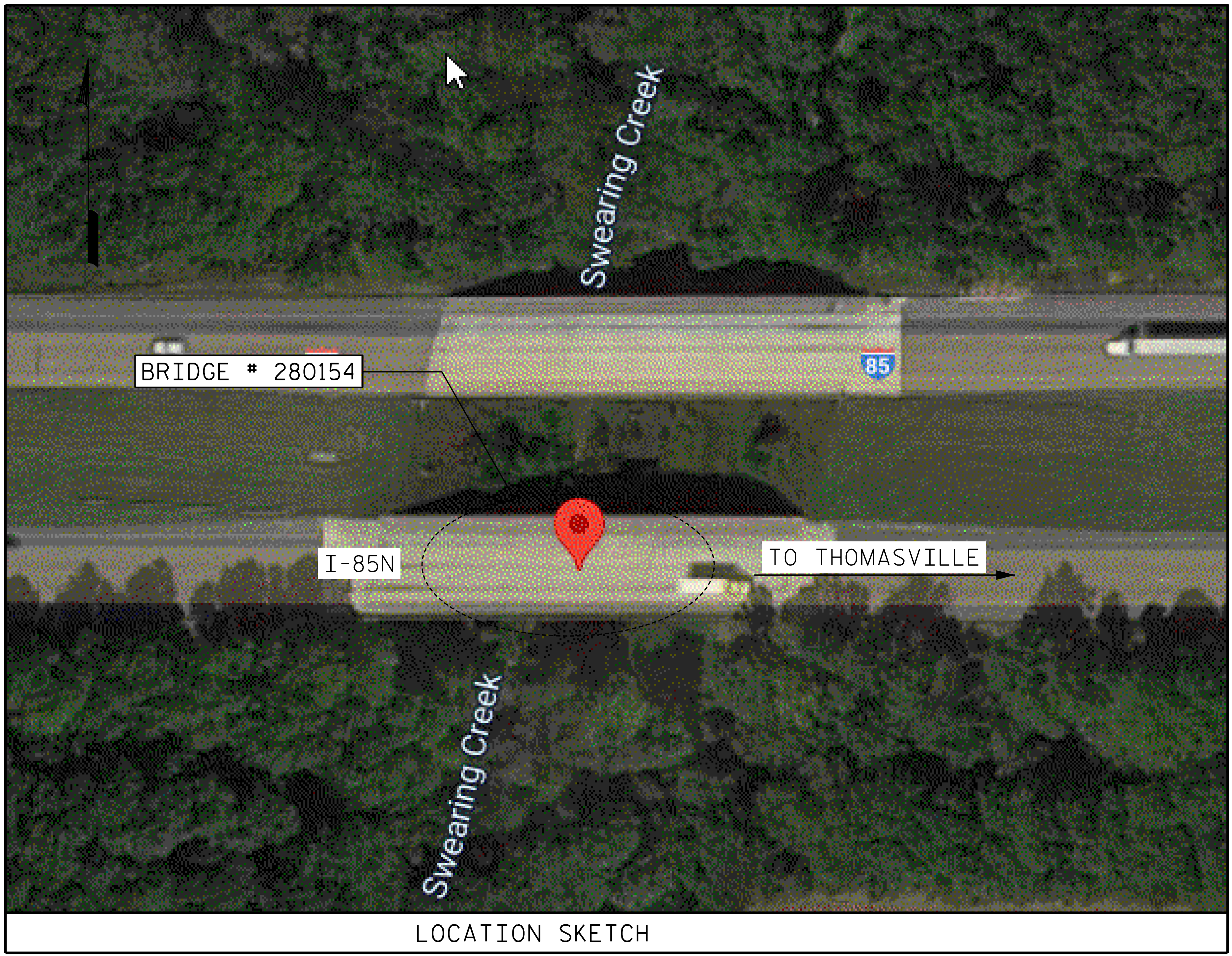

LOCATION SKETCH

BRIDGE COORDINATES		
BRIDGE No.	LATITUDE	LONGITUDE
280154	35°-46'-35.92"	80°-17'-42.45"

TOTAL BILL OF MATERIAL															
BRIDGE NO. 280154	GROOVING BRIDGE FLOORS	CLASS II SURFACE PREPARATION	RIP RAP CLASS B	GEOTEXTILE FOR DRAINAGE	SHOTCRETE REPAIRS	EPOXY RESIN INJECTION	FOAM JOINT SEALS FOR PRESERVATION	POLYESTER POLYMER CONCRETE MATERIALS	EPOXY POLYMER CONCRETE MATERIALS (ALTERNATE)	EPOXY COATING	CONCRETE FOR DECK REPAIR FOR POLYMER CONCRETE OVERLAY	PLACING & FINISHING POLYMER CONCRETE OVERLAY	SCARIFYING BRIDGE DECK	SHOTBLASTING BRIDGE DECK	CLEANING & PAINTING EXISTING BEARING PLATES
	SO. FT.	SO. YDS.	TON	SO. YDS.	CU. FT.	LIN. FT.	LIN. FT.	CU. YDS.	CU. YDS.	SO. FT.	SO. YDS.	SO. YDS.	SO. YDS.	SO. YDS.	EA.
TOTAL	15,110.0	12.8	585.0	650.0	64.2	6.0	116.0	63.1	63.1	1,265.9	12.8	1,816.2	1,816.2	1,816.2	16

NOTES

INFORMATION INDICATED ON THE LOCATION SKETCH SHALL BE CONSIDERED GENERAL INFORMATION ONLY. THE CONTRACTOR SHALL CONFIRM, THROUGH OTHER SOURCES, SPECIFIC INFORMATION REGARDING BRIDGES, ROADWAYS, UTILITIES, THE SURROUNDING AREA, AND ANY OTHER ASPECTS THAT MAY BE NECESSARY TO PERFORM AND COMPLETE THE PROJECT.

EXISTING DIMENSIONS AND BRIDGE CONDITION ARE FROM THE BEST INFORMATION AVAILABLE. THE CONTRACTOR SHALL FIELD VERIFY THE INFORMATION SHOWN ON THE PLANS AND NOTIFY THE ENGINEER IF ACTUAL DIMENSIONS AND CONDITIONS DIFFER.

THE CONTRACTOR SHALL HAVE NO CLAIM WHATSOEVER AGAINST THE DEPARTMENT FOR ANY DELAYS OF ADDITIONAL COST INCURRED BASED ON DIFFERENCES BETWEEN WHAT IS SHOWN ON THE PLANS AND THE ACTUAL CONDITIONS AT THE PROJECT SITE.

IT IS THE CONTRACTOR'S RESPONSIBILITY TO FOLLOW ALL STATE AND FEDERAL SAFETY REQUIREMENTS.

FOR CONTROL OF TRAFFIC AND LIMITS ON PHASING OF CONSTRUCTION, SEE TRANSPORTATION MANAGEMENT PLANS.

EXISTING JOINTS AND DECK DRAINS SHALL BE SEALED PRIOR TO BEGINNING SURFACE PREPARATIONS OF THE BRIDGE DECK. THE CONTRACTOR SHALL TAKE CARE THAT ANY CONSTRUCTION DEBRIS THAT COLLECTS IN THE DRAINS IS CONTAINED. DRAINS IN SHOULDERS OF ADJACENT TRAVEL LANE(S) SHALL BE KEPT FREE AND CLEAR OF DEBRIS.

LONGITUDINAL CONSTRUCTION JOINTS OF OVERLAYS SHALL BE LOCATED ALONG THE CENTERLINE OR EDGE OF TRAVEL LANES.

FOR FOAM JOINT SEALS FOR PRESERVATION, SEE SPECIAL PROVISIONS.

FOR EPOXY RESIN INJECTION, SEE SPECIAL PROVISIONS.

FOR CONCRETE REPAIRS, SEE SPECIAL PROVISIONS.

FOR SHOTCRETE REPAIRS, SEE SPECIAL PROVISIONS.

FOR SUBMITTAL OF WORKING DRAWINGS, SEE SPECIAL PROVISIONS.

FOR FALSEWORK AND FORMWORK, SEE SPECIAL PROVISIONS.

FOR CRANE SAFETY, SEE SPECIAL PROVISIONS.

FOR SCARIFYING BRIDGE DECK, SHOTBLASTING BRIDGE DECK AND CLASS II SURFACE PREPARATION, SEE OVERLAY SURFACE PREPARATION FOR POLYMER CONCRETE SPECIAL PROVISION.

FOR CONCRETE DECK REPAIR FOR PC OVERLAY, PC MATERIALS, AND PLACING AND FINISHING PC OVERLAY, SEE POLYMER CONCRETE BRIDGE DECK OVERLAY SPECIAL PROVISION.

THE CONTRACTOR SHALL PERFORM ALL WORK WITH CARE SO THAT THE EXISTING STRUCTURE WHICH IS TO REMAIN IN PLACE WILL NOT BE DAMAGED. IF THE CONTRACTOR DAMAGES ANY PART OF THE EXISTING STRUCTURE WHICH IS TO REMAIN IN PLACE, THE DAMAGED AREA SHALL BE REPAIRED OR REPLACED IN A MANNER SATISFACTORY TO THE ENGINEER AT NO ADDITIONAL COST TO THE DEPARTMENT.

SHOTCRETE REPAIRS MAY BE REPLACED WITH CONCRETE REPAIRS WITH THE APPROVAL OF THE ENGINEER.

THE CONTRACTOR SHALL FIELD VERIFY THE EXISTING JOINT OPENING PRIOR TO ORDERING JOINT SEAL MATERIAL. IF ACTUAL JOINT OPENING VARIES FROM THE OPENING INDICATED IN DETAIL BY MORE THAN 1/4", NOTIFY ENGINEER. REVISION TO THE JOINT SEAL SIZE MIGHT BE NECESSARY.

FOR GROUT FOR STRUCTURES, SEE SPECIAL PROVISIONS.

FOR CLEANING AND PAINTING EXISTING BEARING PLATES, SEE SPECIAL PROVISIONS.

FOR CLASS B RIP RAP, SEE SPECIAL PROVISIONS.

THE EXISTING BRIDGE DECK SHALL BE REPAIRED AS SHOWN ON THE PLANS OR AS DETERMINED BY THE ENGINEER AFTER SCARIFICATION AND PRIOR TO THE SURFACE PREPARATION AND APPLICATION OF THE PC OVERLAY. UNLESS OTHERWISE APPROVED, SUCH LOCATIONS SHALL BE REPAIRED WITH POLYMER CONCRETE.

FOR EPOXY COATING AND DEBRIS REMOVAL, SEE SPECIAL PROVISIONS.

FOR ANCHOR BOLT NUT REPLACEMENT AND TIGHTENING, SEE SPECIAL PROVISIONS.

WORK ON THE BRIDGE SHALL BE PERFORMED SO AS NOT TO ALLOW DEBRIS TO FALL BELOW. THE CONTRACTOR SHALL SUBMIT PLANS FOR CONSTRUCTION IN ACCORDANCE WITH ARTICLE 402-2 OF THE STANDARD SPECIFICATIONS AND THE PROJECT SPECIAL PROVISIONS.

PRIOR TO BEGINNING WORK, THE CONTRACTOR SHALL SUBMIT FOR REVIEW AND APPROVAL A COMPLETE SEQUENCE OF TASKS FOR EACH OPERATION AFFECTING THE BRIDGE SURFACE AND/OR TRAFFIC.

THE CONTRACTOR SHALL PROVIDE INDEPENDENT ASSURANCE SAMPLES OF REINFORCING STEEL AS FOLLOWS: FOR PROJECTS REQUIRING UP TO 400 TONS OF REINFORCING STEEL, ONE 30 INCH SAMPLE OF EACH SIZE BAR USED, AND FOR PROJECTS REQUIRING OVER 400 TONS OF REINFORCING STEEL, TWO 30 INCH SAMPLES OF EACH SIZE BAR USED. THE SAMPLE BARS SHOULD COME FROM STEEL ACTUALLY USED IN THE PROJECT AND THE SAMPLE BARS SHOULD BE REPLACED BY SPICED BARS AS SPECIFIED IN THE SAMPLE BAR REPLACEMENT CHART. PAYMENT FOR THE SAMPLE BARS AND REPLACEMENT REINFORCING STEEL SHALL BE CONSIDERED INCIDENTAL TO VARIOUS PAY ITEMS.

IT IS THE CONTRACTOR'S RESPONSIBILITY TO IDENTIFY AND DETERMINE PRECISE LOCATIONS OF ALL UTILITIES WITHIN THE WORK AREA PRIOR TO BEGINNING WORK. SPECIAL CARE SHALL BE USED IN WORKING AROUND OR NEAR EXISTING UTILITIES, PROTECTING THEM WHEN NECESSARY. UTILITIES DAMAGED BY THE CONTRACTOR SHALL BE PAID AT NO COST TO THE DEPARTMENT.

AT THE TIME OF PREPARATION OF THESE PLANS, IT WAS NOT ANTICIPATED THAT THE FOLLOWING ITEM(S) LISTED WOULD BE REQUIRED. HOWEVER, IT MAY BE DETERMINED IN THE FIELD THAT THE FOLLOWING ITEM(S) LISTED, OR OTHER WORK WILL BE NECESSARY TO PROPERLY COMPLETE THE INTENDED BRIDGE PRESERVATION/REHABILITATION WORK. THE CONTRACTOR SHALL BE PREPARED TO PERFORM SUCH WORK IN A TIMELY MANNER, AS DETERMINED IN THE FIELD. SUCH WORK SHALL BE CONSIDERED EXTRA WORK AND SHALL BE ADDRESSED AS PER ARTICLE 104-7 OF THE STANDARD SPECIFICATIONS. PROJECT SPECIAL PROVISIONS THAT OUTLINE REQUIREMENTS FOR THESE POTENTIAL ADDITIONAL WORK ITEMS HAVE BEEN PROVIDED IN THE PROJECT DOCUMENTS, BUT NO QUANTITIES HAVE BEEN LISTED. ACTUAL PAY ITEMS, QUANTITIES, AND COSTS WILL BE ESTABLISHED, AS REQUIRED, IF EXTRA WORK IS ENCOUNTERED.

UNANTICIPATED ITEMS:

ITEM NO.	DESCRIPTION	UNIT
1	CONCRETE REPAIRS	CU.FT.

PROJECT NO. I-5950  
DAVIDSON COUNTY  
 BRIDGE NO. 280154

SHEET 2 OF 2

STATE OF NORTH CAROLINA  
 DEPARTMENT OF TRANSPORTATION  
 RALEIGH

GENERAL DRAWING  
 FOR BRIDGE ON  
 I-85N OVER  
 SWEARING CREEK

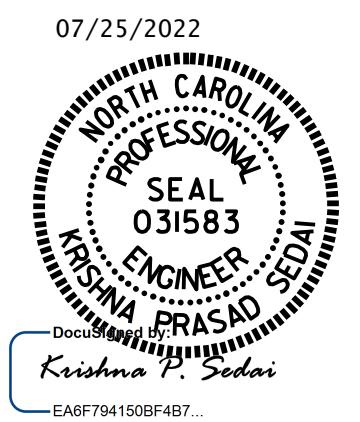

DRAWN BY : S. AGUILAR HERNANDEZ DATE : 07/2020  
 CHECKED BY : E. BAYISSA DATE : 07/2022

REVISIONS						SHEET NO.
NO.	BY:	DATE:	NO.	BY:	DATE:	
1			3			66-02
2			4			TOTAL SHEETS 15

DOCUMENT NOT CONSIDERED FINAL UNLESS ALL SIGNATURES COMPLETED

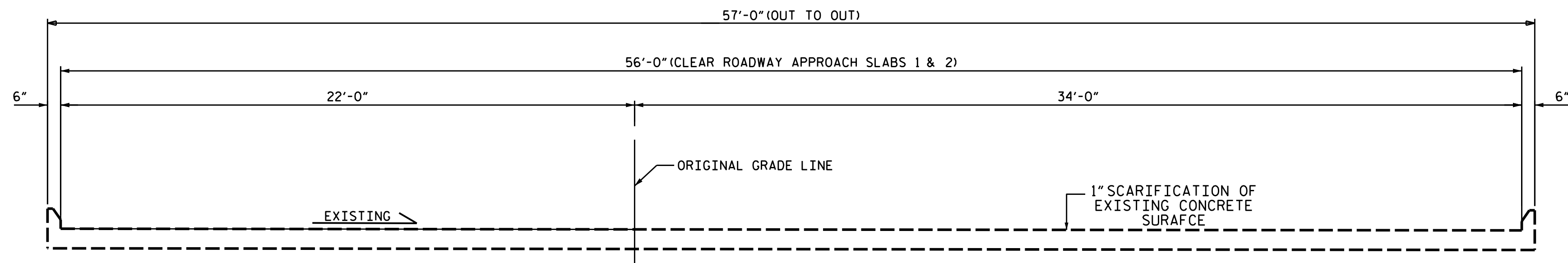

**TYPICAL SECTION - APPROACH SLAB**  
(EXISTING)

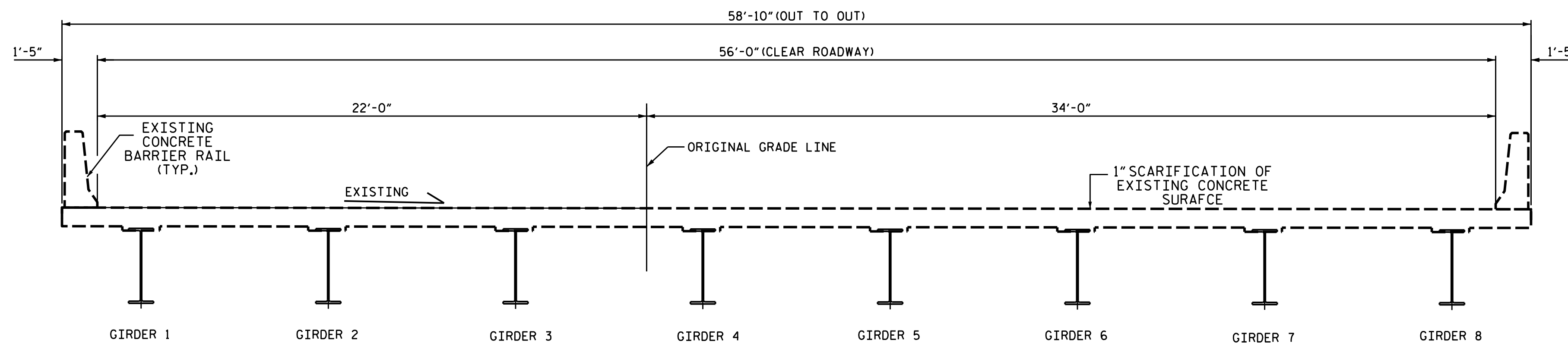

**TYPICAL SECTION**  
(EXISTING)

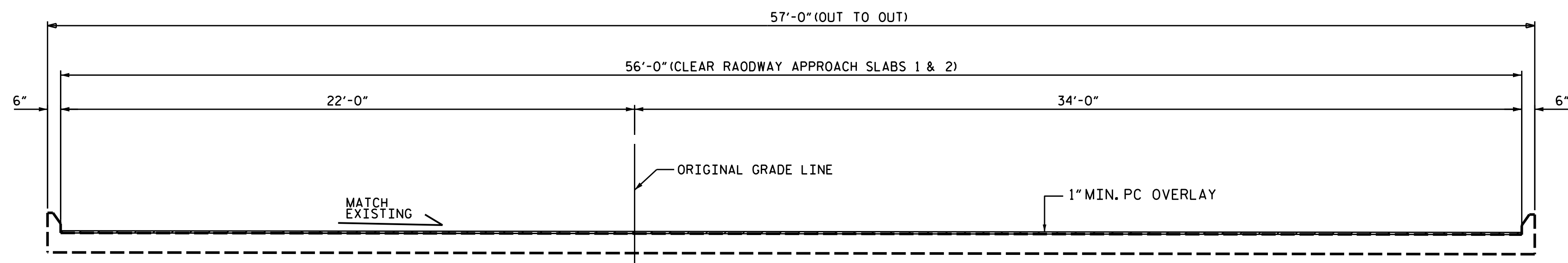

**TYPICAL SECTION - APPROACH SLAB**  
(PROPOSED)

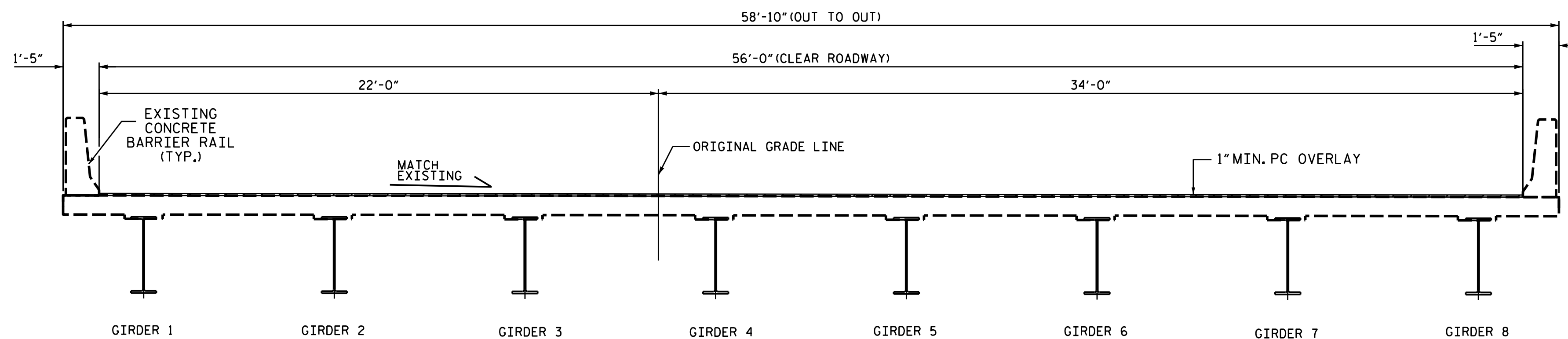

**TYPICAL SECTION**  
(PROPOSED)

**NOTE**

SEE TRANSPORTATION MANAGEMENT PLANS FOR LANE WIDTHS, SEQUENCING AND OTHER TRAFFIC CONTROL MEASURES FOR STAGING OF POLYMER CONCRETE (PC) OVERLAY SYSTEM AND SURFACE PREPARATION.

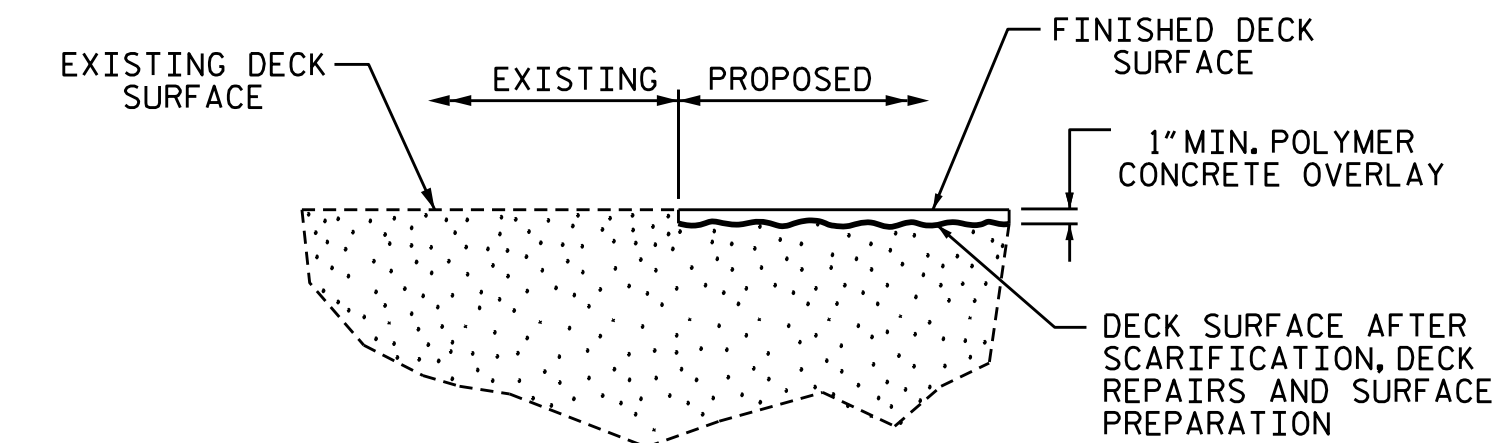

**DETAIL FOR POLYMER CONCRETE OVERLAY**  
FINISHED SURFACE ELEVATION SHALL MATCH EXISTING CONCRETE SURFACE ELEVATION. ACTUAL THICKNESS OF PC OVERLAY MAY VARY.

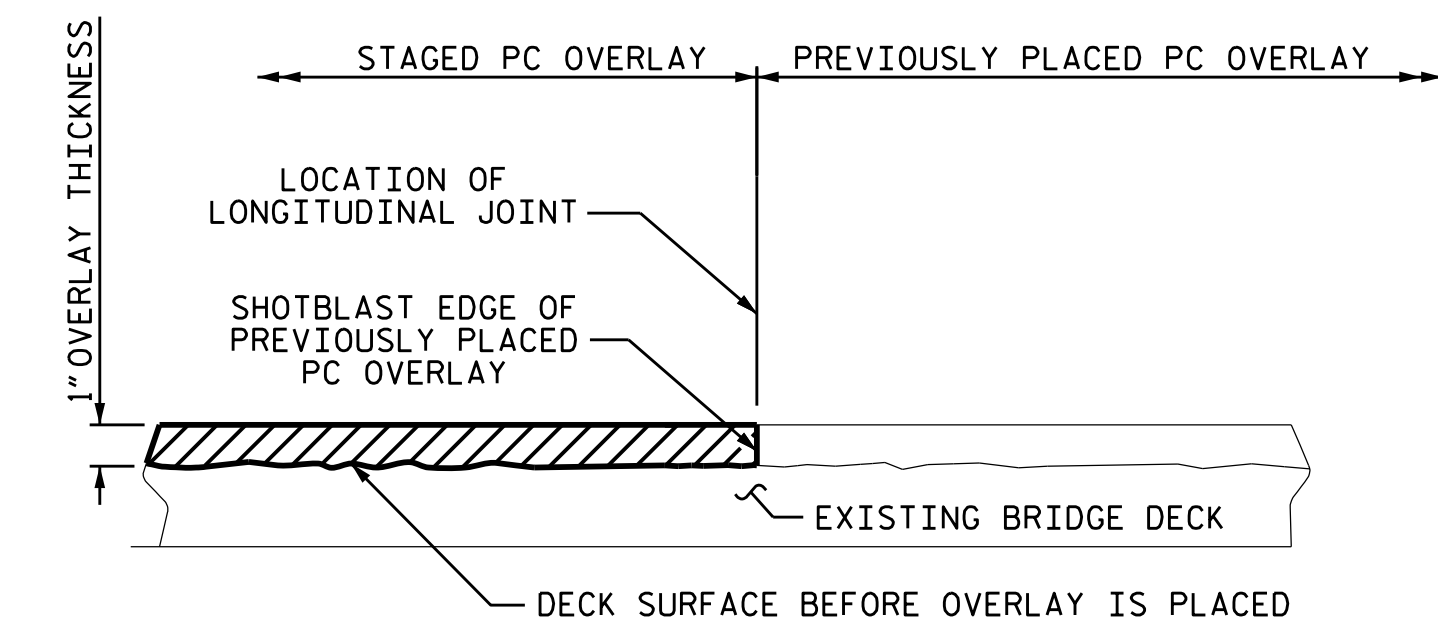

**STAGED PC OVERLAY JOINT**  
(AS NEEDED)

PROJECT NO. I-5950  
DAVIDSON COUNTY  
BRIDGE NO. 280154

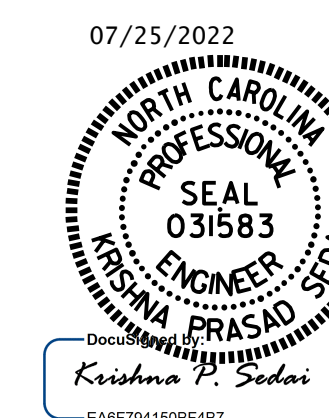

STATE OF NORTH CAROLINA  
DEPARTMENT OF TRANSPORTATION  
RALEIGH  
**TYPICAL SECTION AND PC OVERLAY DETAILS**

DRAWN BY : S. AGUILAR HERNANDEZ DATE : 07/2022  
CHECKED BY : E. BAYISSA DATE : 04/2022

7/25/2022  
S:\DPS3\I-5950\Final Plans\406\_005\_I5950\_SMU.TS.S03\_280154.dgn  
ksedal

REVISIONS						SHEET NO.
NO.	BY:	DATE:	NO.	BY:	DATE:	S6-03
1			3			TOTAL SHEETS
2			4			15

DOCUMENT NOT CONSIDERED FINAL UNLESS ALL SIGNATURES COMPLETED

**NOTES:**

REPAIR LOCATIONS AND ESTIMATE OF QUANTITIES ARE BASED ON THE BEST INFORMATION AVAILABLE. IF ADDITIONAL REPAIRS NOT SHOWN ON THE DRAWINGS ARE DEEMED NECESSARY BY THE ENGINEER, THE ENGINEER WILL NOTE ON THE DRAWINGS THE APPROXIMATE LOCATIONS AND DESCRIPTION OF THE REPAIRS AND ENTER THE ACTUAL QUANTITIES INTO THE AS-BUILT REPAIR QUANTITY TABLE.



FOR CONCRETE DECK REPAIR FOR PC OVERLAY, PC MATERIALS, AND PLACING AND FINISHING PC OVERLAY, SEE POLYMER CONCRETE BRIDGE DECK OVERLAY SPECIAL PROVISION.

FOR SECTION A-A, SEE "JOINT DETAILS" SHEET.

DECK SURFACE REPAIR QUANTITIES REPRESENT ESTIMATED VALUES OF CLASS II SURFACE PREPARATION AND CONCRETE DECK REPAIR FOR PC OVERLAY AFTER REMOVAL OF UNSOUND CONCRETE (MIN. 2" CLEAR TO SAWCUT.) SEE OVERLAY SURFACE PREPARATION FOR POLYMER CONCRETE SPECIAL PROVISION.

FOR SCARIFYING BRIDGE DECK, SHOTBLASTING BRIDGE DECK AND CLASS II SURFACE PREPARATION, SEE OVERLAY SURFACE PREPARATION FOR POLYMER CONCRETE SPECIAL PROVISION.

THE OVERLAY SHALL BRING THE TOP ELEVATION OF THE SETTLING PART OF THE APPROACH SLAB EVEN WITH THE BRIDGE DECK.

-  CLASS II SURFACE PREPARATION
-  SHOTCRETE REPAIR
-  EPOXY RESIN INJECTION (ERI)

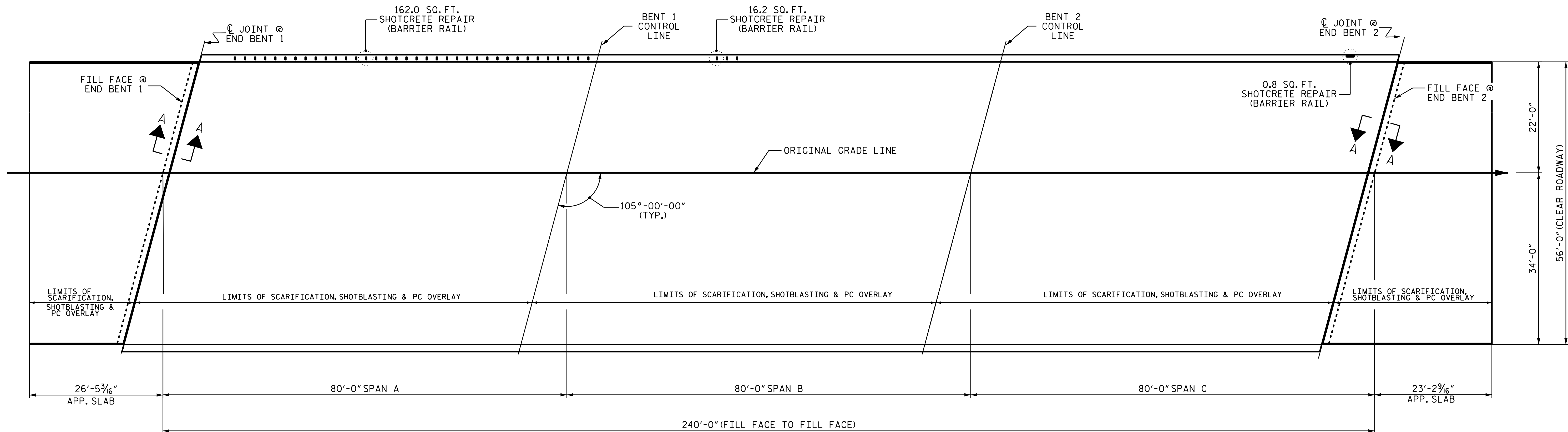

**PLAN OF SPANS**

**AS-BUILT REPAIR QUANTITY TABLE**

TOP OF DECK REPAIRS	APPROACH SLAB 1		SPAN A		SPAN B		SPAN C		APPROACH SLAB 2	
	ESTIMATE	ACTUAL	ESTIMATE	ACTUAL	ESTIMATE	ACTUAL	ESTIMATE	ACTUAL	ESTIMATE	ACTUAL
SCARIFYING BRIDGE DECK	160.5 SQ. YDS.		498.2 SQ. YDS.		498.8 SQ. YDS.		498.2 SQ. YDS.		160.5 SQ. YDS.	
SHOTBLASTING BRIDGE DECK	160.5 SQ. YDS.		498.2 SQ. YDS.		498.8 SQ. YDS.		498.2 SQ. YDS.		160.5 SQ. YDS.	
CLASS II SURFACE PREPARATION	3.2 SQ. YDS.		3.2 SQ. YDS.		0.0 SQ. YDS.		3.2 SQ. YDS.		3.2 SQ. YDS.	
CONCRETE DECK REPAIR FOR PC OVERLAY	3.2 SQ. YDS.		3.2 SQ. YDS.		0.0 SQ. YDS.		3.2 SQ. YDS.		3.2 SQ. YDS.	
POLYMER CONCRETE MATERIALS	5.6 CU. YDS.		17.3 CU. YDS.		17.3 CU. YDS.		17.3 CU. YDS.		5.6 CU. YDS.	
PLACING & FINISHING PC OVERLAY	160.5 SQ. YDS.		498.2 SQ. YDS.		498.8 SQ. YDS.		498.2 SQ. YDS.		160.5 SQ. YDS.	
GROOVING BRIDGE FLOOR	1295.7 SQ. FT.		4139.4 SQ. FT.		4240.0 SQ. FT.		4139.4 SQ. FT.		1295.5 SQ. FT.	
EPOXY RESIN INJECTION			0.0 LIN. FT.		0.0 LIN. FT.		0.0 LIN. FT.			
SHOTCRETE REPAIRS			ACTUAL		ESTIMATE		ACTUAL		ESTIMATE	
	AREA SQ. FT.	VOLUME CU. FT.	AREA SQ. FT.	VOLUME CU. FT.	AREA SQ. FT.	VOLUME CU. FT.	AREA SQ. FT.	VOLUME CU. FT.	AREA SQ. FT.	VOLUME CU. FT.
CONCRETE BARRIER RAIL			162.0	54.0	16.2	5.4	0.8	0.3		

PROJECT NO. I-5950  
DAVIDSON COUNTY  
 BRIDGE NO. 280154

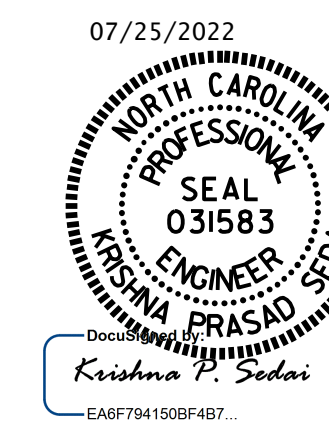

STATE OF NORTH CAROLINA  
 DEPARTMENT OF TRANSPORTATION  
 RALEIGH  
**DECK SURFACE REPAIR**  
**SPANS A, B AND C**  
**AND**  
**APPROACH SLABS**

DRAWN BY : S. AGUILAR HERNANDEZ DATE : 07/2020  
 CHECKED BY : E. BAYISSA DATE : 04/2022

DOCUMENT NOT CONSIDERED  
 FINAL UNLESS ALL  
 SIGNATURES COMPLETED

REVISIONS						SHEET NO.
NO.	BY:	DATE:	NO.	BY:	DATE:	
1			3			56-04
2			4			TOTAL SHEETS 15

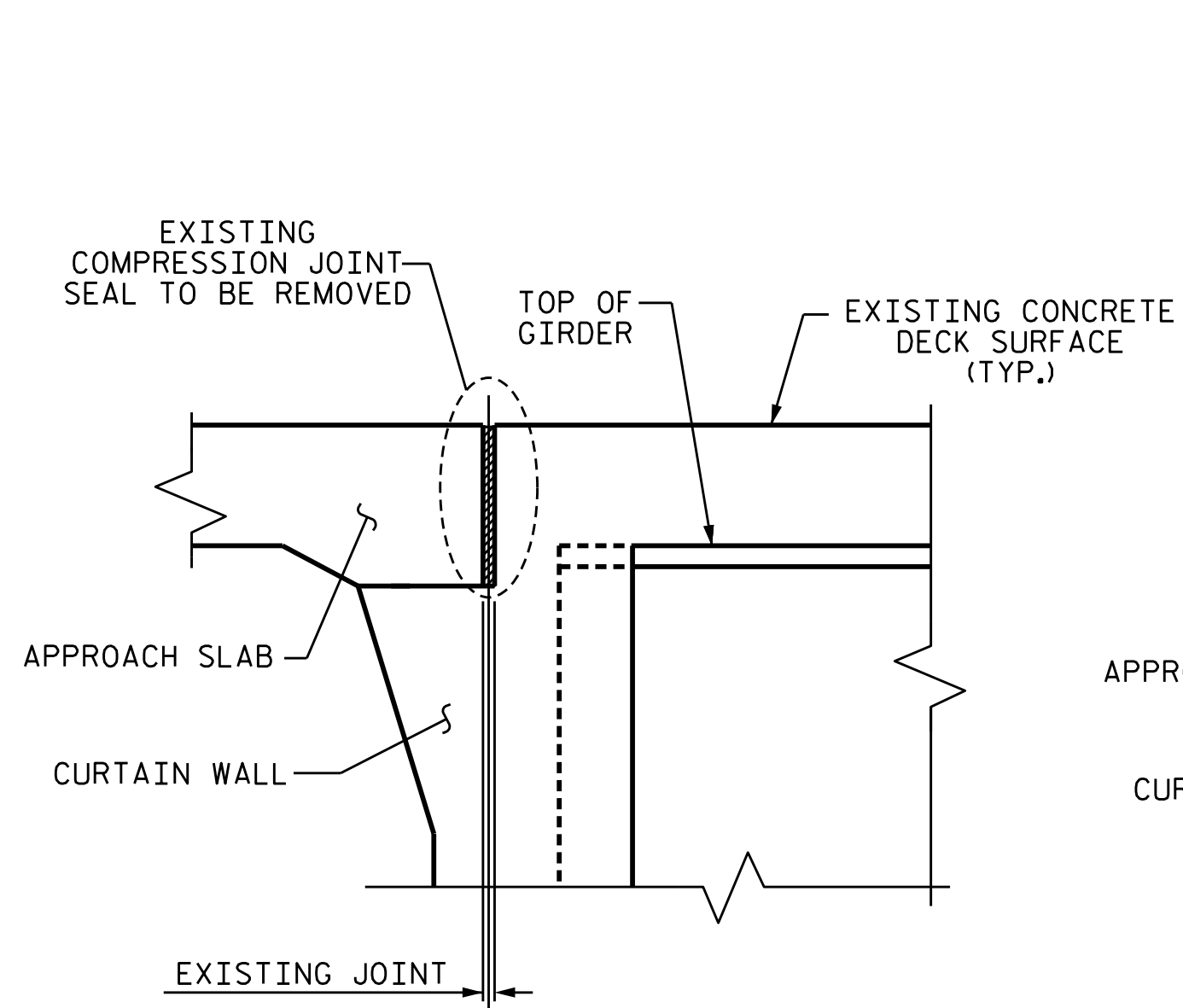

EXISTING JOINT

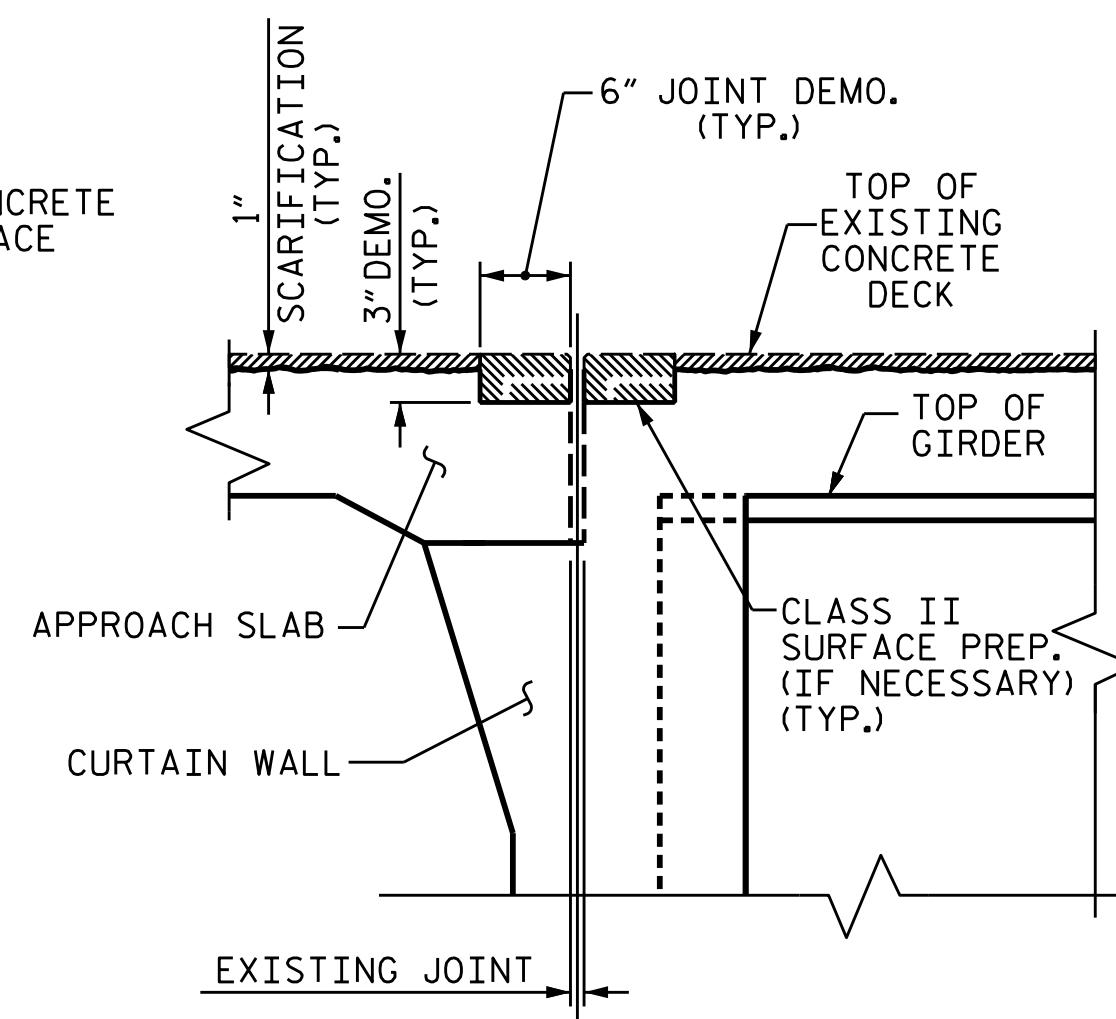

MINIMUM EXISTING JOINT DEMOLITION & SCARIFICATION

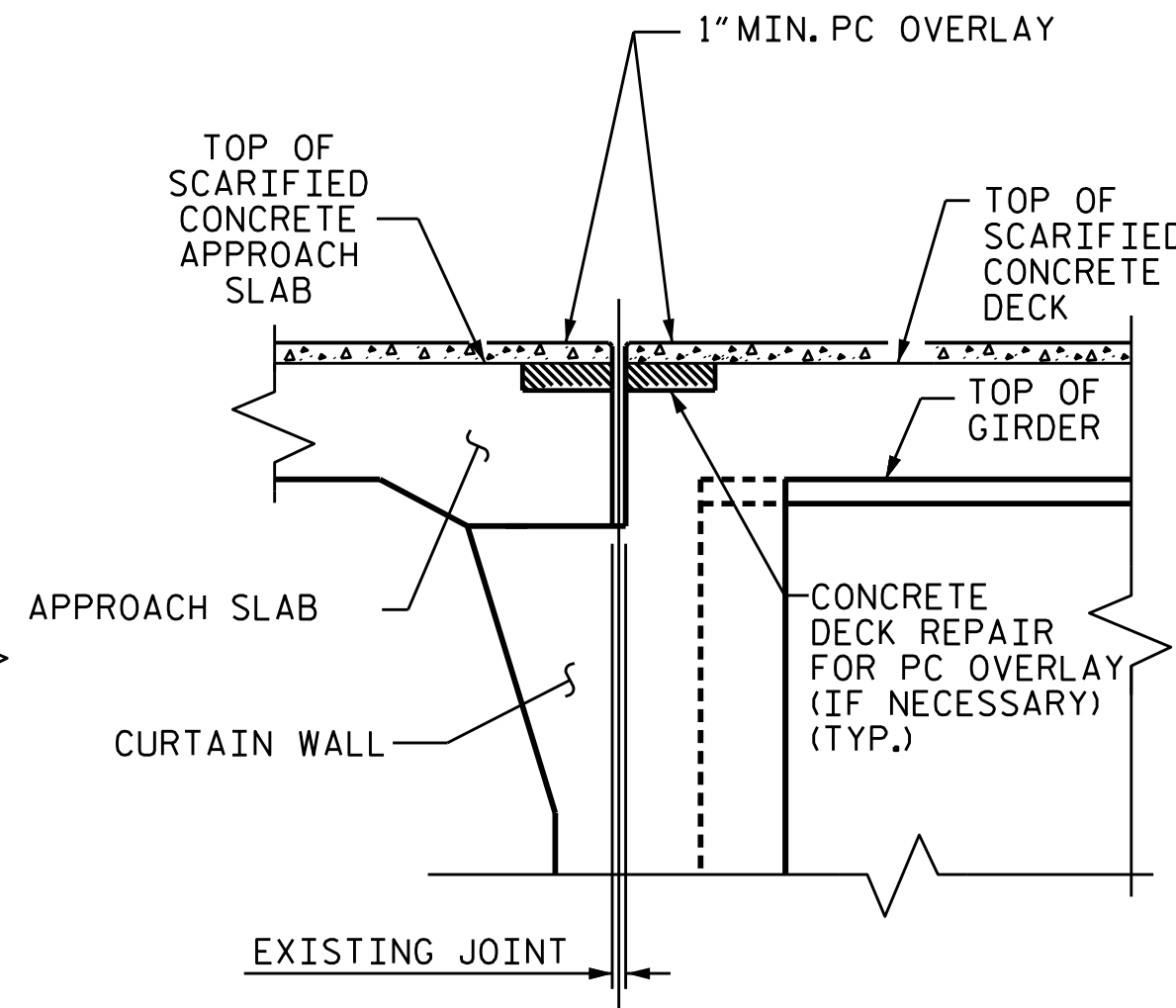

PROPOSED JOINT PRE-SAWED & PC OVERLAY

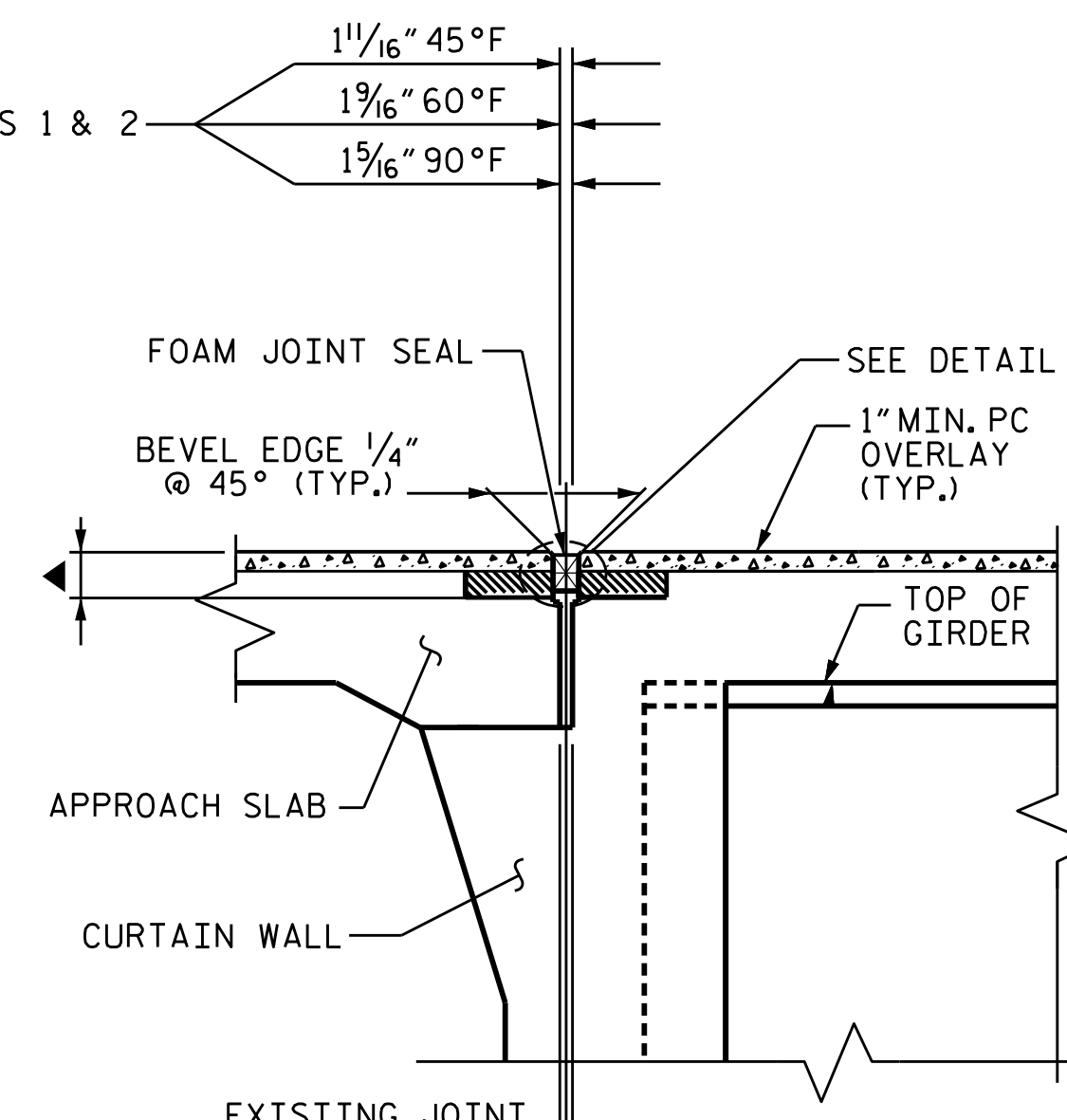

PROPOSED FOAM JOINT SEAL

▲ SAW CUT SHALL BE 1" BELOW THE BOTTOM OF FOAM JOINT SEAL. SEE MANUFACTURER RECOMMENDATIONS

NOTE

THE CONTRACTOR SHALL FIELD VERIFY THE EXISTING JOINT OPENING PRIOR TO ORDERING JOINT SEAL MATERIAL. IF ACTUAL JOINT OPENING VARIES FROM THE OPENING INDICATED IN DETAIL BY MORE THAN 1/4", NOTIFY ENGINEER. REVISION TO THE JOINT SEAL SIZE MIGHT BE NECESSARY.

FINAL JOINT SEALS SHALL NOT BE INSTALLED UNTIL THE OVERLAY IS COMPLETE.

THE CONTRACTOR SHALL TAKE CARE DURING JOINT REHAB OPERATIONS NOT TO DROP ANY MATERIAL BELOW THE BRIDGE WITHOUT PROTECTIVE DEVICES BELOW TO CATCH THE MATERIAL. ANY MATERIAL THAT FALLS BELOW THE BRIDGE SHALL BE CONTAINED, REMOVED AND DISPOSED OF BY THE CONTRACTOR AT NO EXTRA COST TO THE DEPARTMENT. IF THE ENGINEER DETERMINES THAT THE PROTECTIVE DEVICES ARE NOT ADEQUATE OR NOT BEING EMPLOYED, THE WORK SHALL BE SUSPENDED UNTIL ADEQUATE PROTECTION IS PROVIDED.

THE CONTRACTOR WILL NOT BE PERMITTED TO FORM THE JOINTS IN LIEU OF SAWING THE JOINT.

THE INSTALLATION OF THE JOINT SEAL SHALL BE WATERTIGHT.

DURING THE JOINT INSTALLATION PROCEDURE, THE JOINT AND SURROUNDING AREA SHALL BE KEPT CLEAN AND FREE OF DEBRIS.

THE MANUFACTURER IS TO PROVIDE THE NOMINAL UNCOMPRESSED SEAL WIDTH OF THE FOAM JOINT SEAL FOR THE SIZE OF THE OPENING ON THE PLANS AND THAT ACCOMMODATE THE MINIMUM EXPANSION SHOWN ON THE PLANS.

A MANUFACTURER'S CERTIFIED TRAINED REPRESENTATIVE SHALL BE PRESENT DURING THE INSTALLATION OF THE FIRST JOINT OF THE PROJECT, OR UNTIL THE ENGINEER IS SATISFIED WITH THE INSTALL PROCESS.

FINAL SURFACE OF THE JOINT DEMOLITION AREA PRIOR TO PLACEMENT OF CONCRETE REPAIR MATERIAL SHOULD BE REASONABLY FLAT AND LEVEL. ENGINEER SHALL DETERMINE THE ACCEPTABILITY OF THE SURFACE PRIOR TO PLACEMENT OF REPAIR CONCRETE.

FOR FOAM JOINT SEALS FOR PRESERVATION, SEE SPECIAL PROVISIONS.

JOINT INSTALLATION SEQUENCE AT END BENTS

SECTION A-A

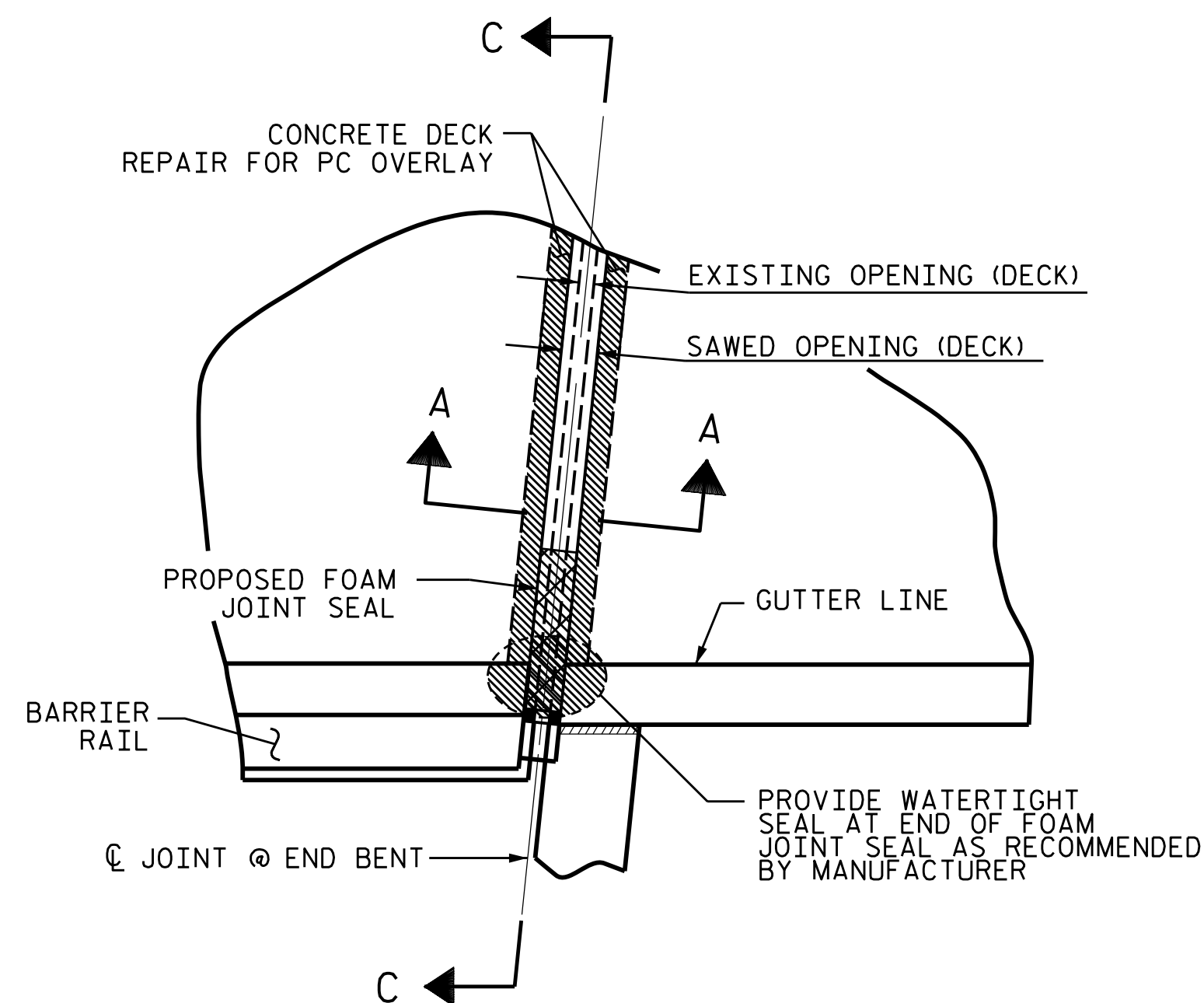

PLAN

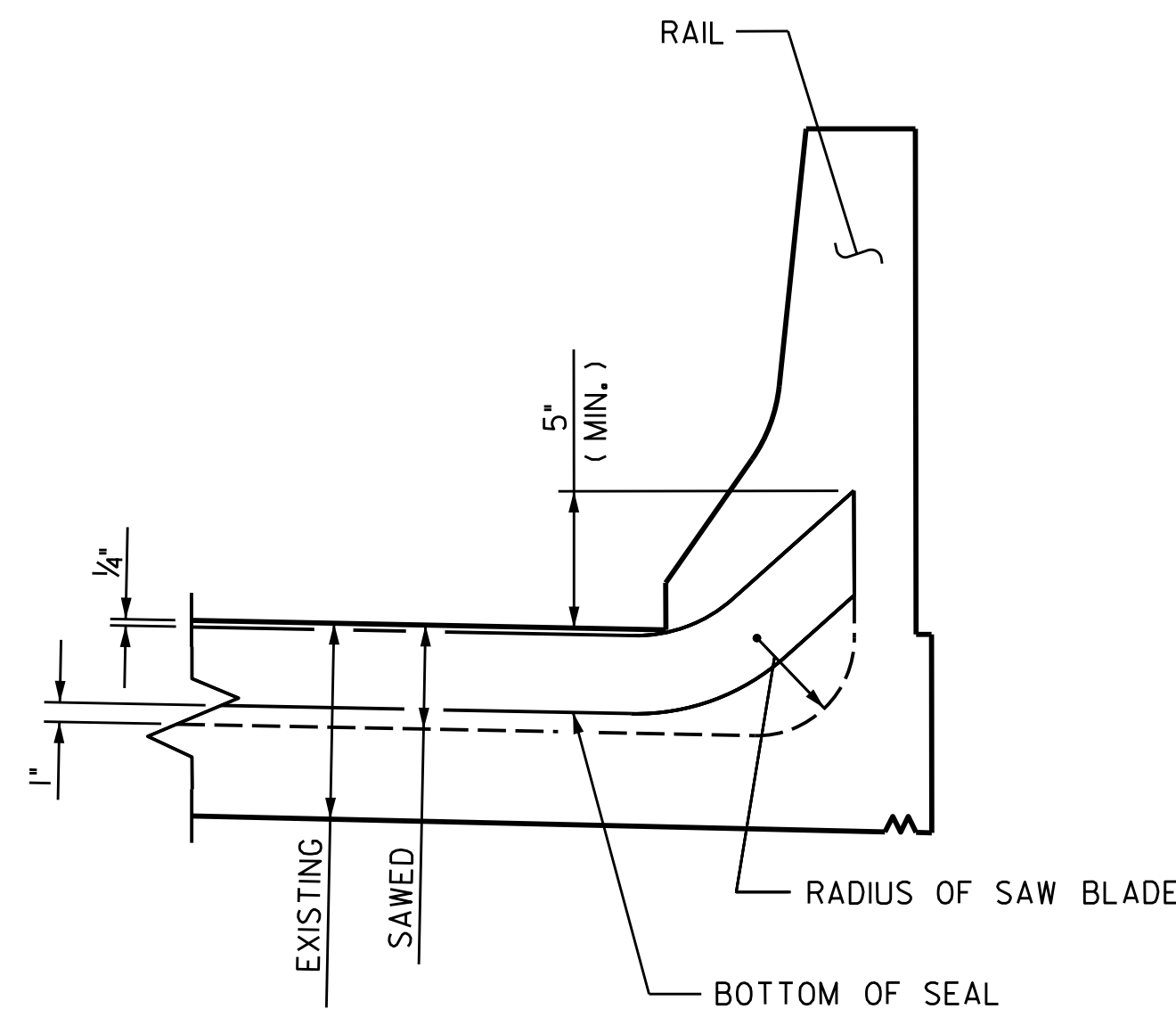

SECTION C-C

JOINT SEAL DETAILS AT END BENTS

JOINT REPAIR QUANTITY TABLE		
	ESTIMATE	ACTUAL
FOAM JOINT SEAL FOR PRESERVATION		
END BENT 1	58.0 LF	
END BENT 2	58.0 LF	
TOTAL	116.0 LF	

PROJECT NO. I-5950  
 DAVIDSON COUNTY  
 BRIDGE NO. 280154

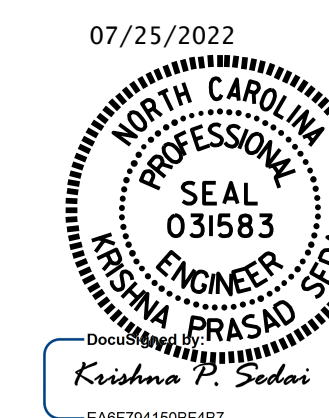

STATE OF NORTH CAROLINA  
 DEPARTMENT OF TRANSPORTATION  
 RALEIGH

JOINT REPAIR DETAILS

DRAWN BY: S. AGUILAR HERNANDEZ DATE: 07/2020  
 CHECKED BY: E. BAYISSA DATE: 03/2022

DOCUMENT NOT CONSIDERED FINAL UNLESS ALL SIGNATURES COMPLETED

REVISIONS						SHEET NO.
NO.	BY:	DATE:	NO.	BY:	DATE:	
1			3			S6-05
2			4			TOTAL SHEETS 15



### AS-BUILT REPAIR QUANTITY TABLE

DECK UNDERSIDE REPAIRS SPAN A	QUANTITIES			
	ESTIMATE		ACTUAL	
SHOTCRETE REPAIRS	AREA SF	VOLUME CF	AREA SF	VOLUME CF
UNDERSIDE OF DECK	0	0		
CONCRETE DIAPHRAGM	0	0		
OVERHANG	0	0		
CONCRETE REPAIRS	AREA SF	VOLUME CF	AREA SF	VOLUME CF
UNDERSIDE OF DECK	0	0		
CONCRETE DIAPHRAGM	0	0		
OVERHANG	0	0		
EPOXY RESIN INJECTION		LIN. FT.		LIN. FT.
UNDERSIDE OF DECK				
CONCRETE DIAPHRAGM				
OVERHANG				

VALUES IN CHART REPRESENT ESTIMATED REPAIR TOTALS AFTER REMOVAL OF UNSOUND CONCRETE, MIN. OF 1" BEHIND REBAR AND MIN. 2" CLEAR TO SAWCUT. SEE REPAIR DETAILS.

#### NOTES

REPAIR LOCATIONS AND ESTIMATE OF QUANTITIES ARE GIVEN BASED ON THE BEST INFORMATION AVAILABLE. IF ADDITIONAL REPAIRS NOT SHOWN ON THE DRAWINGS ARE DEEMED NECESSARY BY THE ENGINEER, THE ENGINEER SHALL NOTE ON THE DRAWINGS THE APPROXIMATE LOCATION AND DESCRIPTION OF THE REPAIRS AND ENTER THE ACTUAL QUANTITIES INTO THE AS-BUILT REPAIR QUANTITY TABLE.

CONTRACTOR SHALL SAW CUT TO A NOMINAL DEPTH OF 1/2" BUT REINFORCING STEEL SHALL NOT BE DAMAGED.

CONTRACTOR SHALL REMOVE SURFACE CONCRETE TO VERIFY THAT SAWCUT DEPTH WILL NOT DAMAGE EXISTING REINFORCING STEEL.

SHOTCRETE REPAIRS MAYBE SUBSTITUTED IN LIEU OF CONCRETE REPAIRS WITH THE APPROVAL OF THE ENGINEER.

FOR UNDERSIDE OF DECK REPAIRS, SEE "OVERHANG, DIAPHRAGM AND BRIDGE RAIL REPAIR DETAILS" SHEET.

FOR SHOTCRETE REPAIRS, SEE SPECIAL PROVISIONS.

FOR CONCRETE REPAIRS, SEE SPECIAL PROVISIONS.

FOR EPOXY RESIN INJECTION, SEE SPECIAL PROVISIONS.

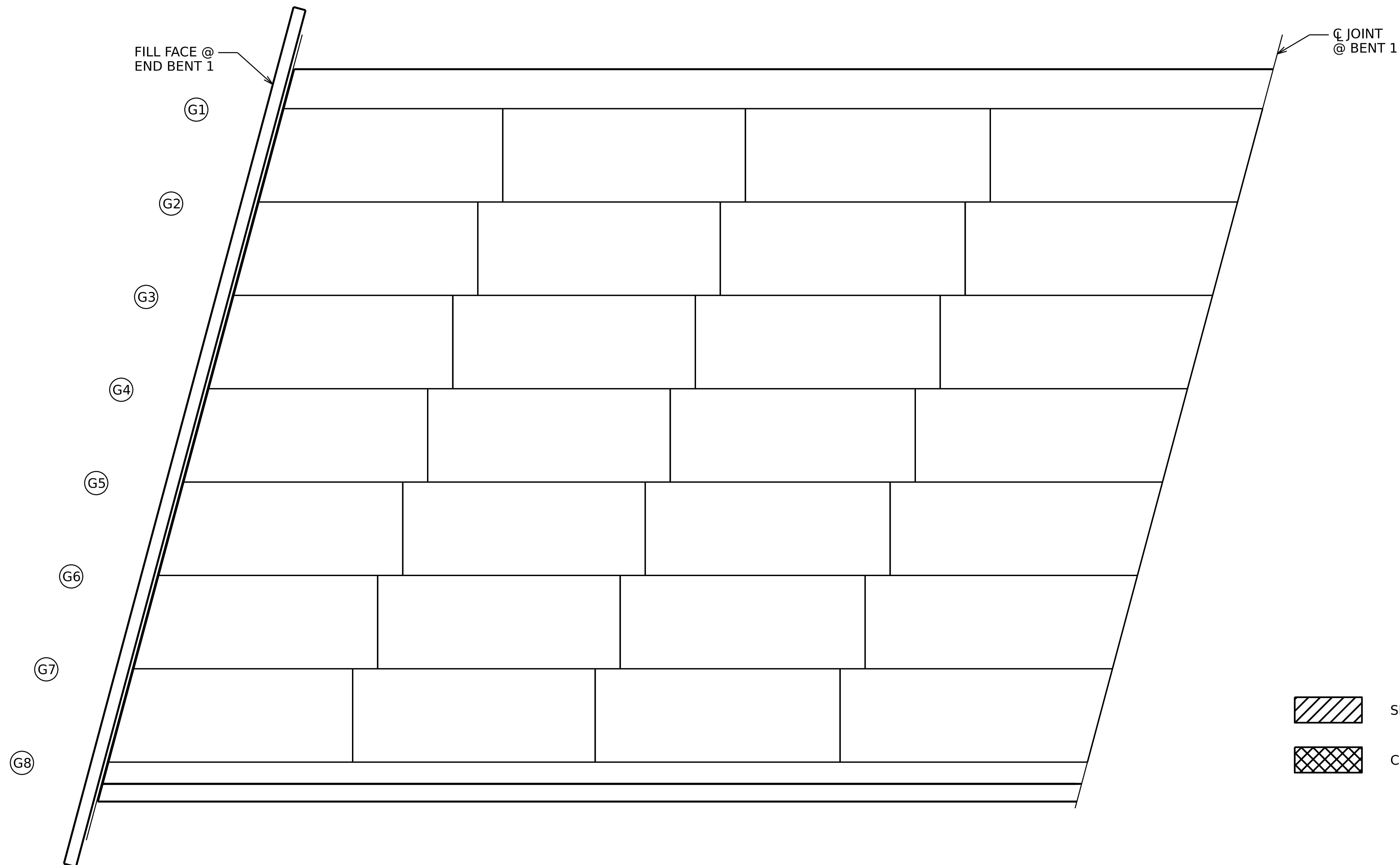

**SPAN A**

PROJECT NO. **I-5950**  
**DAVIDSON** COUNTY  
 BRIDGE NO. **280154**

SHEET 1 OF 3

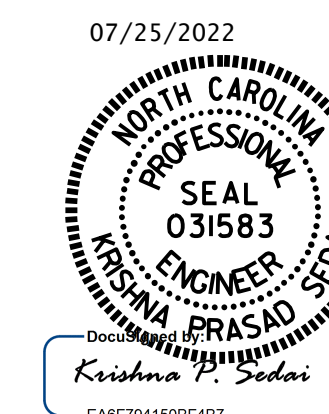

STATE OF NORTH CAROLINA  
 DEPARTMENT OF TRANSPORTATION  
 RALEIGH  
**DECK UNDERSIDE REPAIR**  
**SPAN A**

DRAWN BY : E. BAYISSA DATE : 09/2021  
 CHECKED BY : A. SORSENGINH DATE : 04/2022

DOCUMENT NOT CONSIDERED  
 FINAL UNLESS ALL  
 SIGNATURES COMPLETED

REVISIONS						SHEET NO.
NO.	BY:	DATE:	NO.	BY:	DATE:	
1			3			S6-06
2			4			TOTAL SHEETS 15

### AS-BUILT REPAIR QUANTITY TABLE

DECK UNDERSIDE REPAIRS SPAN B	QUANTITIES			
	ESTIMATE		ACTUAL	
SHOTCRETE REPAIRS	AREA SF	VOLUME CF	AREA SF	VOLUME CF
UNDERSIDE OF DECK	0	0		
CONCRETE DIAPHRAGM	0	0		
OVERHANG	0	0		
<b>CONCRETE REPAIRS</b>	<b>AREA SF</b>	<b>VOLUME CF</b>	<b>AREA SF</b>	<b>VOLUME CF</b>
UNDERSIDE OF DECK	0	0		
CONCRETE DIAPHRAGM	0	0		
OVERHANG	0	0		
<b>EPOXY RESIN INJECTION</b>		<b>LIN. FT.</b>		<b>LIN. FT.</b>
UNDERSIDE OF DECK				
CONCRETE DIAPHRAGM				
OVERHANG				

VALUES IN CHART REPRESENT ESTIMATED REPAIR TOTALS AFTER REMOVAL OF UNSOUND CONCRETE, MIN. OF 1" BEHIND REBAR AND MIN. 2" CLEAR TO SAWCUT. SEE REPAIR DETAILS.

#### NOTES

REPAIR LOCATIONS AND ESTIMATE OF QUANTITIES ARE GIVEN BASED ON THE BEST INFORMATION AVAILABLE. IF ADDITIONAL REPAIRS NOT SHOWN ON THE DRAWINGS ARE DEEMED NECESSARY BY THE ENGINEER, THE ENGINEER SHALL NOTE ON THE DRAWINGS THE APPROXIMATE LOCATION AND DESCRIPTION OF THE REPAIRS AND ENTER THE ACTUAL QUANTITIES INTO THE AS-BUILT REPAIR QUANTITY TABLE.

CONTRACTOR SHALL SAW CUT TO A NOMINAL DEPTH OF 1/2" BUT REINFORCING STEEL SHALL NOT BE DAMAGED.

CONTRACTOR SHALL REMOVE SURFACE CONCRETE TO VERIFY THAT SAWCUT DEPTH WILL NOT DAMAGE EXISTING REINFORCING STEEL.

SHOTCRETE REPAIRS MAYBE SUBSTITUTED IN LIEU OF CONCRETE REPAIRS WITH THE APPROVAL OF THE ENGINEER.

FOR UNDERSIDE OF DECK REPAIRS, SEE "OVERHANG, DIAPHRAGM AND BRIDGE RAIL REPAIR DETAILS" SHEET.

PRIOR TO CLEANING AND PAINTING, REPLACE AND /OR TIGHTEN ANCHOR BOLT NUTS. SEE SPECIAL PROVISIONS.



FOR SHOTCRETE REPAIRS, SEE SPECIAL PROVISIONS.

FOR CONCRETE REPAIRS, SEE SPECIAL PROVISIONS.

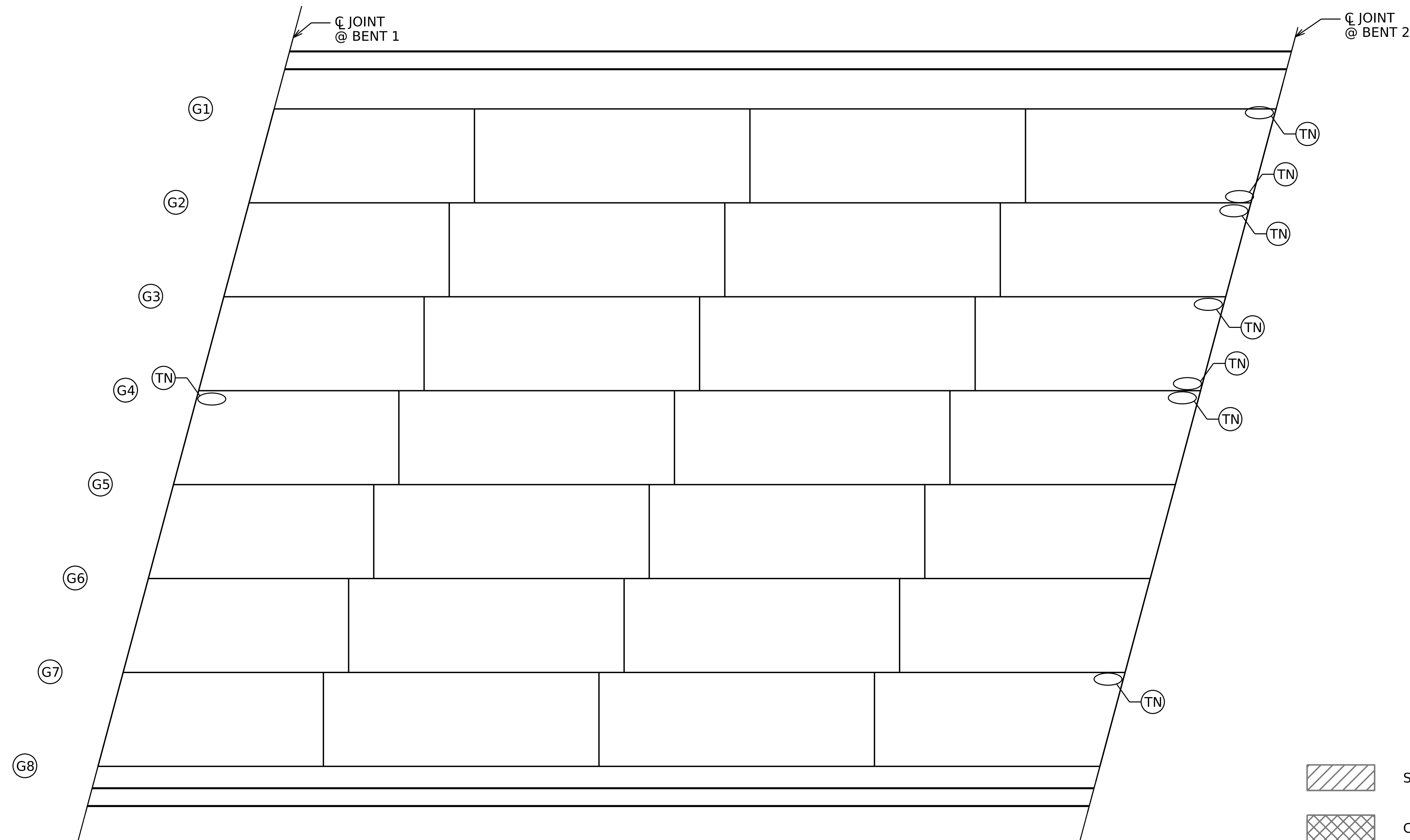
FOR EPOXY RESIN INJECTION, SEE SPECIAL PROVISIONS.



**SPAN B**

-  SHOTCRETE REPAIR AREA
-  CONCRETE REPAIR AREA
-  TIGHTEN ANCHOR BOLT NUT

PROJECT NO. **I-5950**  
**DAVIDSON** COUNTY  
 BRIDGE NO. **280154**

SHEET 2 OF 3

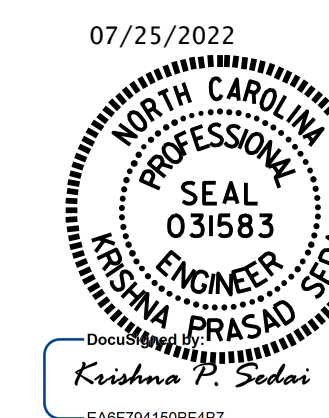

STATE OF NORTH CAROLINA  
 DEPARTMENT OF TRANSPORTATION  
 RALEIGH  
**DECK UNDERSIDE REPAIR**  
**SPAN B**

DRAWN BY : E. BAYISSA DATE : 09/2021  
 CHECKED BY : A. SORSENGINH DATE : 04/2022

DOCUMENT NOT CONSIDERED  
 FINAL UNLESS ALL  
 SIGNATURES COMPLETED

REVISIONS						SHEET NO.
NO.	BY:	DATE:	NO.	BY:	DATE:	
1			3			S6-07
2			4			TOTAL SHEETS 15

### AS-BUILT REPAIR QUANTITY TABLE

DECK UNDERSIDE REPAIRS SPAN C	QUANTITIES			
	ESTIMATE		ACTUAL	
SHOTCRETE REPAIRS	AREA SF	VOLUME CF	AREA SF	VOLUME CF
UNDERSIDE OF DECK	0	0		
CONCRETE DIAPHRAGM	0	0		
OVERHANG	0	0		
CONCRETE REPAIRS	AREA SF	VOLUME CF	AREA SF	VOLUME CF
UNDERSIDE OF DECK	0	0		
CONCRETE DIAPHRAGM	0	0		
OVERHANG	0	0		
EPOXY RESIN INJECTION		LIN. FT.		LIN. FT.
UNDERSIDE OF DECK				
CONCRETE DIAPHRAGM				
OVERHANG				

VALUES IN CHART REPRESENT ESTIMATED REPAIR TOTALS AFTER REMOVAL OF UNSOUND CONCRETE, MIN. OF 1" BEHIND REBAR AND MIN. 2" CLEAR TO SAWCUT. SEE REPAIR DETAILS.

#### NOTES

REPAIR LOCATIONS AND ESTIMATE OF QUANTITIES ARE GIVEN BASED ON THE BEST INFORMATION AVAILABLE. IF ADDITIONAL REPAIRS NOT SHOWN ON THE DRAWINGS ARE DEEMED NECESSARY BY THE ENGINEER, THE ENGINEER SHALL NOTE ON THE DRAWINGS THE APPROXIMATE LOCATION AND DESCRIPTION OF THE REPAIRS AND ENTER THE ACTUAL QUANTITIES INTO THE AS-BUILT REPAIR QUANTITY TABLE.

CONTRACTOR SHALL SAW CUT TO A NOMINAL DEPTH OF 1/2" BUT REINFORCING STEEL SHALL NOT BE DAMAGED.

CONTRACTOR SHALL REMOVE SURFACE CONCRETE TO VERIFY THAT SAWCUT DEPTH WILL NOT DAMAGE EXISTING REINFORCING STEEL.

SHOTCRETE REPAIRS MAYBE SUBSTITUTED IN LIEU OF CONCRETE REPAIRS WITH THE APPROVAL OF THE ENGINEER.

FOR UNDERSIDE OF DECK REPAIRS, SEE "OVERHANG, DIAPHRAGM AND BRIDGE RAIL REPAIR DETAILS" SHEET.

FOR SHOTCRETE REPAIRS, SEE SPECIAL PROVISIONS.

FOR CONCRETE REPAIRS, SEE SPECIAL PROVISIONS.

FOR EPOXY RESIN INJECTION, SEE SPECIAL PROVISIONS.

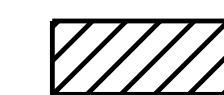

SHOTCRETE REPAIR AREA



CONCRETE REPAIR AREA

PROJECT NO. **I-5950**  
**DAVIDSON** COUNTY  
 BRIDGE NO. **280154**

SHEET 3 OF 3

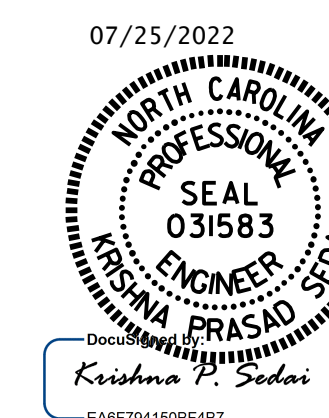

STATE OF NORTH CAROLINA  
 DEPARTMENT OF TRANSPORTATION  
 RALEIGH

### DECK UNDERSIDE REPAIR SPAN C

REVISIONS						SHEET NO.
NO.	BY:	DATE:	NO.	BY:	DATE:	S6-08
1			3			TOTAL SHEETS
2			4			15

DOCUMENT NOT CONSIDERED  
 FINAL UNLESS ALL  
 SIGNATURES COMPLETED

DRAWN BY : E. BAYISSA DATE : 09/2021  
 CHECKED BY : A. SORSENGINH DATE : 04/2022

C JOINT @ BENT 2

FILL FACE @ END BENT 2

G1

G2

G3

G4

G5

G6

G7

G8

SPAN C

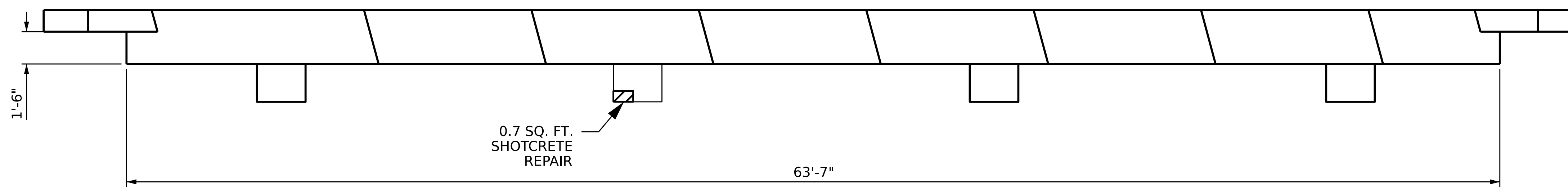

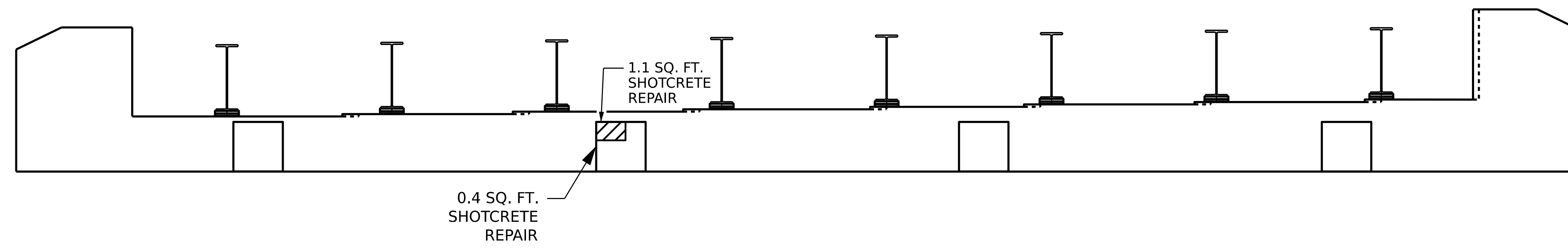

**PLAN**

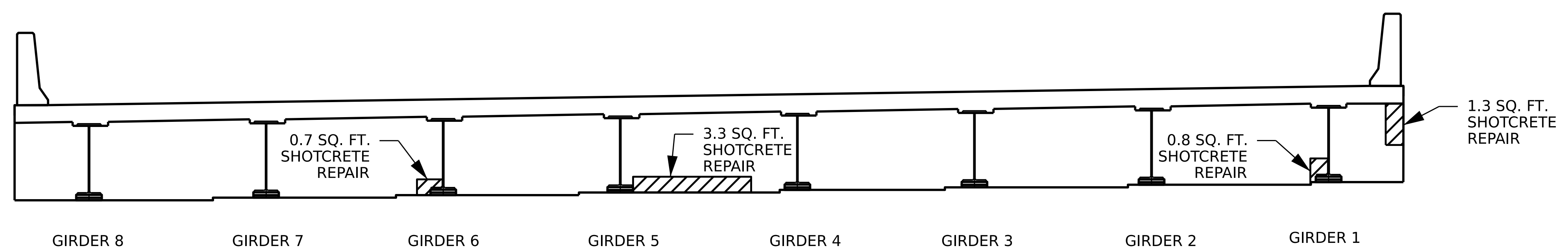

**ELEVATION**



**TYPICAL SECTION**

-  SHOTCRETE REPAIR AREA
-  CONCRETE REPAIR AREA
-  EPOXY RESIN INJECTION

AS-BUILT REPAIR QUANTITY TABLE				
REPAIRS - END BENT 1	QUANTITIES			
	ESTIMATE		ACTUAL	
SHOTCRETE REPAIRS	AREA SF	VOLUME CF	AREA SF	VOLUME CF
CAP	2.2	1.1		
CURTAIN WALL	4.8	2.4		
WINGWALL				
CONCRETE REPAIRS	AREA SF	VOLUME CF	AREA SF	VOLUME CF
CAP	0	0		
CURTAIN WALL	0	0		
WINGWALL				
EPOXY RESIN INJECTION		LINEAR FT		LINEAR FT
CAP		0		
CURTAIN WALL		0		
WINGWALL				
EPOXY COATING		AREA SF		AREA SF
CAP		95.4		
CURTAIN WALL		258.6		

VALUES IN CHART REPRESENT ESTIMATED REPAIR TOTALS AFTER REMOVAL OF UNSOUND CONCRETE, MIN. OF 1" BEHIND REBAR AND MIN. 2" CLEAR TO SAWCUT. SEE REPAIR DETAILS.

**NOTES**

REPAIR LOCATIONS AND ESTIMATE OF QUANTITIES ARE GIVEN BASED ON THE BEST INFORMATION AVAILABLE. IF ADDITIONAL REPAIRS NOT SHOWN ON THE DRAWINGS ARE DEEMED NECESSARY BY THE ENGINEER, THE ENGINEER SHALL NOTE ON THE DRAWINGS THE APPROXIMATE LOCATION AND DESCRIPTION OF THE REPAIRS AND ENTER THE ACTUAL QUANTITIES INTO THE AS-BUILT REPAIR QUANTITY TABLE.

CLEAN AND REMOVE DEBRIS FROM THE TOP OF THE CAP AND APPLY EPOXY PROTECTIVE COATING. EPOXY COATING SHALL BE APPLIED TO THE TOP SURFACE OF THE CAP. THE CONTRACTOR SHALL NOT COAT THE AREA OF THE CAP BENEATH THE MASONRY PLATES. FOR EPOXY COATING, SEE SPECIAL PROVISIONS.

SHOTCRETE REPAIRS MAYBE SUBSTITUTED IN LIEU OF CONCRETE REPAIRS WITH THE APPROVAL OF THE ENGINEER.

FOR CAP AND COLUMN REPAIRS, SEE "TYPICAL CAP AND COLUMN REPAIR DETAILS" SHEET.

FOR SHOTCRETE REPAIRS, SEE SPECIAL PROVISIONS.

FOR CONCRETE REPAIRS, SEE SPECIAL PROVISIONS.

PROJECT NO. **I-5950**  
**DAVIDSON** COUNTY  
 BRIDGE NO. **280154**

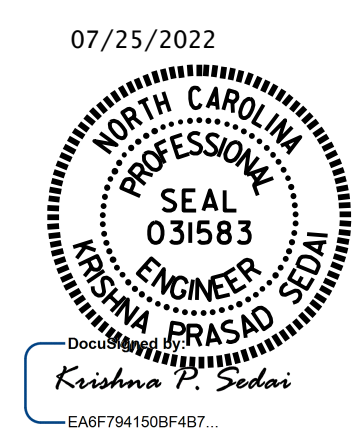

STATE OF NORTH CAROLINA  
 DEPARTMENT OF TRANSPORTATION  
 RALEIGH

**SUBSTRUCTURE REPAIR  
 END BENT 1**

DRAWN BY : S. AGUILAR HERNANDEZ DATE : 07/2020  
 CHECKED BY : E. BAYISSA DATE : 04/2022  
 DESIGN ENGINEER OF RECORD: DATE :

DOCUMENT NOT CONSIDERED  
 FINAL UNLESS ALL  
 SIGNATURES COMPLETED

REVISIONS						SHEET NO. S6-09
NO.	BY:	DATE:	NO.	BY:	DATE:	
1			3			TOTAL SHEETS
2			4			15

### AS-BUILT REPAIR QUANTITY TABLE

REPAIRS - BENT 1	QUANTITIES			
	ESTIMATE		ACTUAL	
<b>SHOTCRETE REPAIRS</b>	AREA SF	VOLUME CF	AREA SF	VOLUME CF
CAP	0.9	0.5		
COLUMN	0	0		
<b>CONCRETE REPAIRS</b>	AREA SF	VOLUME CF	AREA SF	VOLUME CF
CAP	0	0		
COLUMN	0	0		
<b>EPOXY RESIN INJECTION</b>		LINEAR FT		LINEAR FT
CAP		0		
COLUMN		0		
<b>EPOXY COATING</b>		AREA SF		AREA SF
CAP		182.9		
STRUT		98.1		

VALUES IN CHART REPRESENT ESTIMATED REPAIR TOTALS AFTER REMOVAL OF UNSOUND CONCRETE, MIN. OF 1" BEHIND REBAR AND MIN. 2" CLEAR TO SAWCUT. SEE REPAIR DETAILS.

#### NOTES

REPAIR LOCATIONS AND ESTIMATE OF QUANTITIES ARE GIVEN BASED ON THE BEST INFORMATION AVAILABLE. IF ADDITIONAL REPAIRS NOT SHOWN ON THE DRAWINGS ARE DEEMED NECESSARY BY THE ENGINEER, THE ENGINEER SHALL NOTE ON THE DRAWINGS THE APPROXIMATE LOCATION AND DESCRIPTION OF THE REPAIRS AND ENTER THE ACTUAL QUANTITIES INTO THE AS-BUILT REPAIR QUANTITY TABLE.

CLEAN AND REMOVE DEBRIS FROM THE TOP OF THE CAP AND APPLY EPOXY PROTECTIVE COATING. EPOXY COATING SHALL BE APPLIED TO THE TOP SURFACE OF THE CAP. THE CONTRACTOR SHALL NOT COAT THE AREA OF THE CAP BENEATH THE MASONRY PLATES. FOR EPOXY COATING, SEE SPECIAL PROVISIONS.

SHOTCRETE REPAIRS MAYBE SUBSTITUTED IN LIEU OF CONCRETE REPAIRS WITH THE APPROVAL OF THE ENGINEER.

FOR CAP AND COLUMN REPAIRS, SEE "TYPICAL CAP AND COLUMN REPAIR DETAILS" SHEET.

FOR SHOTCRETE REPAIRS, SEE SPECIAL PROVISIONS.

FOR CONCRETE REPAIRS, SEE SPECIAL PROVISIONS.

 SHOTCRETE REPAIR AREA

 CONCRETE REPAIR AREA

 EPOXY RESIN INJECTION

PROJECT NO. **I-5950**

**DAVIDSON** COUNTY

BRIDGE NO. **280154**

SHEET 1 OF 2

STATE OF NORTH CAROLINA  
DEPARTMENT OF TRANSPORTATION  
RALEIGH

**SUBSTRUCTURE REPAIR  
BENT 1  
SPAN A FACE**

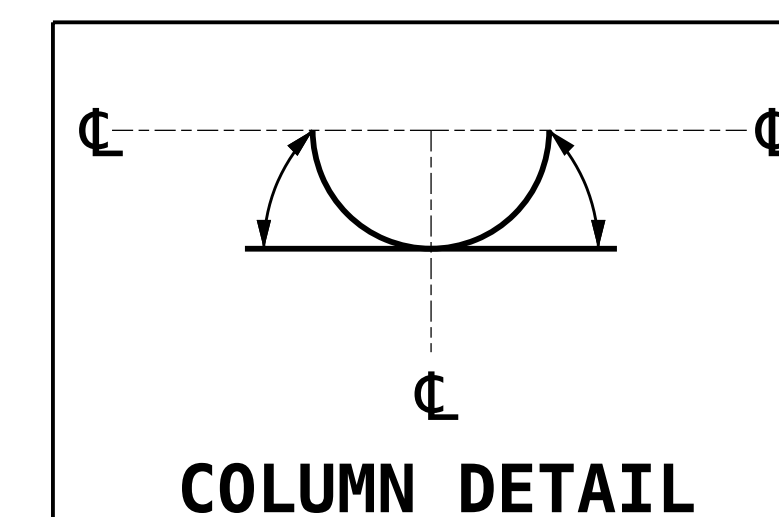

DOCUMENT NOT CONSIDERED FINAL UNLESS ALL SIGNATURES COMPLETED

REVISIONS						SHEET NO.
NO.	BY:	DATE:	NO.	BY:	DATE:	S6-10
1			3			TOTAL SHEETS
2			4			15

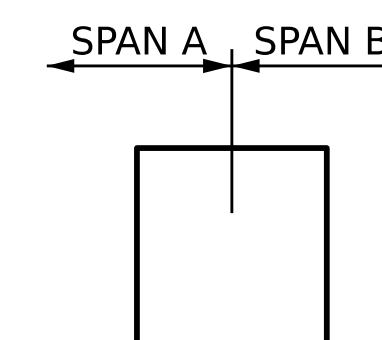
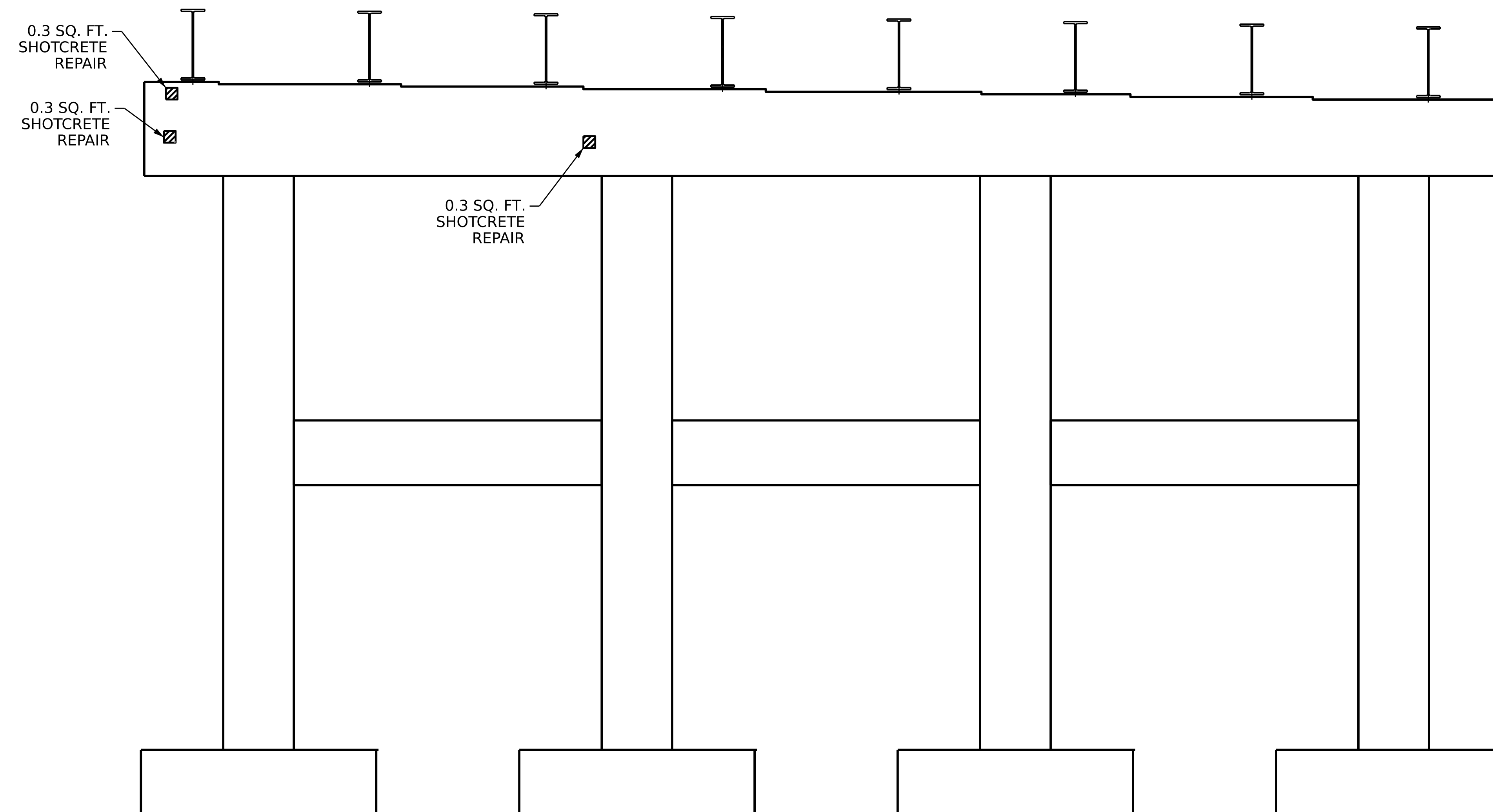
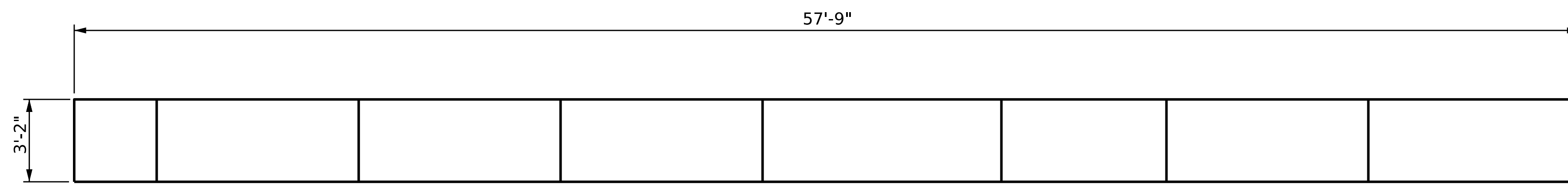

DRAWN BY : S. AGUILAR HERNANDEZ DATE : 07/2020  
 CHECKED BY : E. BAYISSA DATE : 04/2022  
 DESIGN ENGINEER OF RECORD: \_\_\_\_\_ DATE : \_\_\_\_\_



**PLAN - BOTTOM OF CAP**

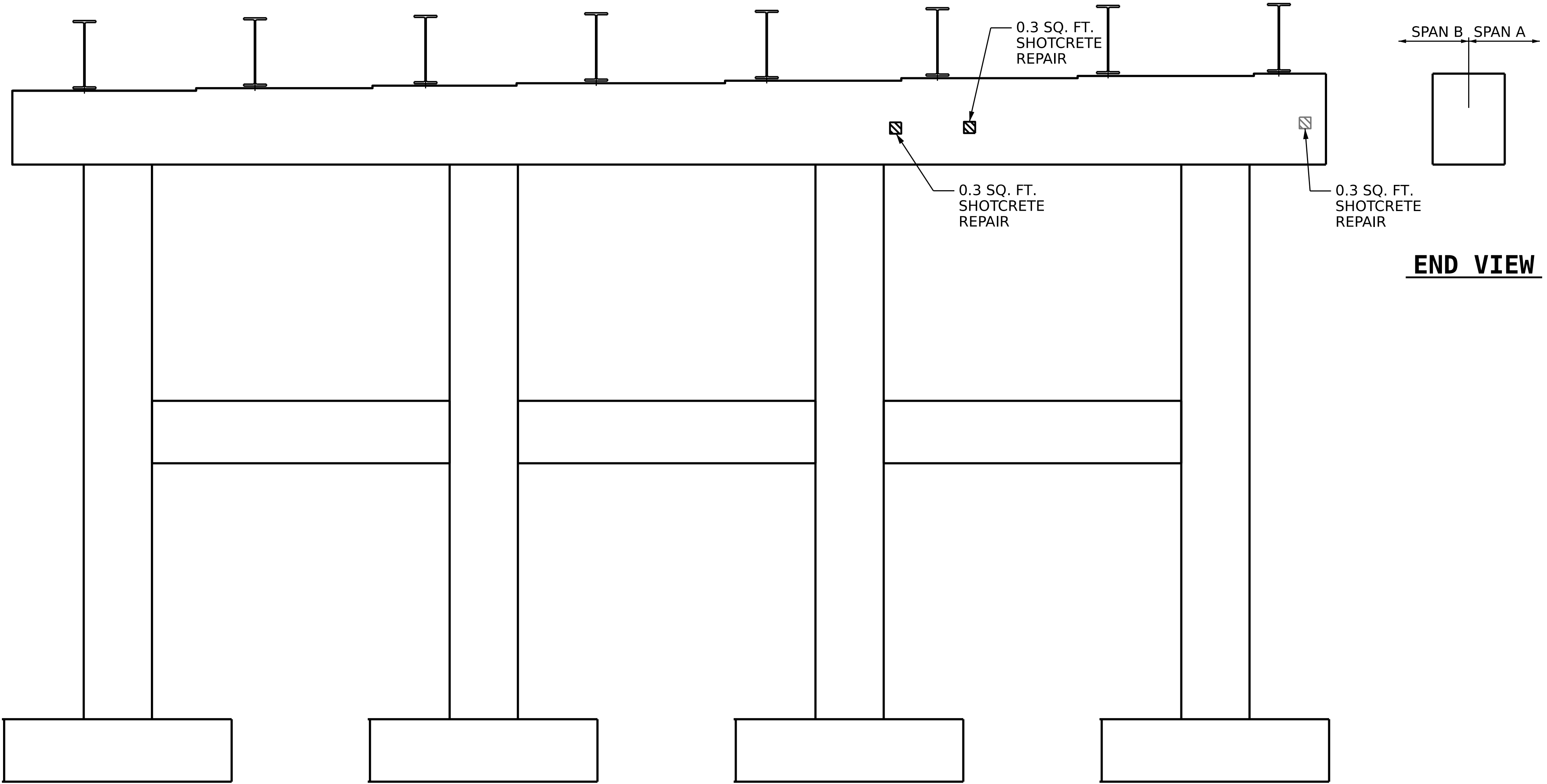

**END VIEW**

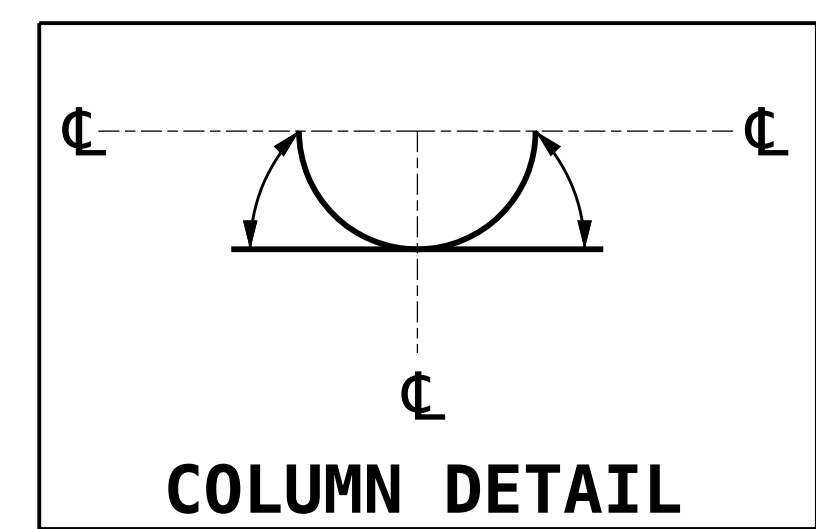

**COLUMN DETAIL**

**AS-BUILT REPAIR QUANTITY TABLE**

REPAIRS - BENT 1	QUANTITIES			
	ESTIMATE		ACTUAL	
SHOTCRETE REPAIRS	AREA SF	VOLUME CF	AREA SF	VOLUME CF
CAP	0.9	0.5		
COLUMN	0	0		
CONCRETE REPAIRS	AREA SF	VOLUME CF	AREA SF	VOLUME CF
CAP	0	0		
COLUMN	0	0		
EPOXY RESIN INJECTION		LINEAR FT		LINEAR FT
CAP		0		
COLUMN		0		

VALUES IN CHART REPRESENT ESTIMATED REPAIR TOTALS AFTER REMOVAL OF UNSOUND CONCRETE, MIN. OF 1" BEHIND REBAR AND MIN. 2" CLEAR TO SAWCUT. SEE REPAIR DETAILS.

**NOTES**

REPAIR LOCATIONS AND ESTIMATE OF QUANTITIES ARE GIVEN BASED ON THE BEST INFORMATION AVAILABLE. IF ADDITIONAL REPAIRS NOT SHOWN ON THE DRAWINGS ARE DEEMED NECESSARY BY THE ENGINEER, THE ENGINEER SHALL NOTE ON THE DRAWINGS THE APPROXIMATE LOCATION AND DESCRIPTION OF THE REPAIRS AND ENTER THE ACTUAL QUANTITIES INTO THE AS-BUILT REPAIR QUANTITY TABLE.

SHOTCRETE REPAIRS MAYBE SUBSTITUTED IN LIEU OF CONCRETE REPAIRS WITH THE APPROVAL OF THE ENGINEER.

FOR CAP AND COLUMN REPAIRS, SEE "TYPICAL CAP AND COLUMN REPAIR DETAILS" SHEET.

FOR SHOTCRETE REPAIRS, SEE SPECIAL PROVISIONS.

FOR CONCRETE REPAIRS, SEE SPECIAL PROVISIONS.

- SHOTCRETE REPAIR AREA
- CONCRETE REPAIR AREA
- EPOXY RESIN INJECTION

PROJECT NO. **I-5950**  
**DAVIDSON** COUNTY  
 BRIDGE NO. **280154**

SHEET 2 OF 2

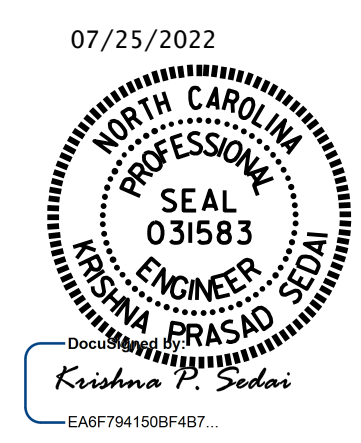

STATE OF NORTH CAROLINA  
 DEPARTMENT OF TRANSPORTATION  
 RALEIGH  
**SUBSTRUCTURE REPAIR  
 BENT 1  
 SPAN B FACE**

DRAWN BY : S. AGUILAR HERNANDEZ DATE : 07/2020  
 CHECKED BY : E. BAYISSA DATE : 04/2022  
 DESIGN ENGINEER OF RECORD: \_\_\_\_\_ DATE : \_\_\_\_\_

DOCUMENT NOT CONSIDERED  
 FINAL UNLESS ALL  
 SIGNATURES COMPLETED

REVISIONS					SHEET NO.
NO.	BY:	DATE:	NO.	BY:	DATE:
1			3		
2			4		

TOTAL SHEETS: 15

### AS-BUILT REPAIR QUANTITY TABLE

REPAIRS - BENT 2	QUANTITIES			
	ESTIMATE		ACTUAL	
<b>SHOTCRETE REPAIRS</b>	AREA SF	VOLUME CF	AREA SF	VOLUME CF
CAP	0.	0.0		
COLUMN	0	0		
<b>CONCRETE REPAIRS</b>	AREA SF	VOLUME CF	AREA SF	VOLUME CF
CAP	0	0		
COLUMN	0	0		
<b>EPOXY RESIN INJECTION</b>		LINEAR FT		LINEAR FT
CAP		0		
COLUMN		0		
<b>EPOXY COATING</b>		AREA SF		AREA SF
CAP		182.9		
STRUT		98.1		

VALUES IN CHART REPRESENT ESTIMATED REPAIR TOTALS AFTER REMOVAL OF UNSOUND CONCRETE, MIN. OF 1" BEHIND REBAR AND MIN. 2" CLEAR TO SAWCUT. SEE REPAIR DETAILS.

#### NOTES

REPAIR LOCATIONS AND ESTIMATE OF QUANTITIES ARE GIVEN BASED ON THE BEST INFORMATION AVAILABLE. IF ADDITIONAL REPAIRS NOT SHOWN ON THE DRAWINGS ARE DEEMED NECESSARY BY THE ENGINEER, THE ENGINEER SHALL NOTE ON THE DRAWINGS THE APPROXIMATE LOCATION AND DESCRIPTION OF THE REPAIRS AND ENTER THE ACTUAL QUANTITIES INTO THE AS-BUILT REPAIR QUANTITY TABLE.

CLEAN AND REMOVE DEBRIS FROM THE TOP OF THE CAP AND APPLY EPOXY PROTECTIVE COATING. EPOXY COATING SHALL BE APPLIED TO THE TOP SURFACE OF THE CAP. THE CONTRACTOR SHALL NOT COAT THE AREA OF THE CAP BENEATH THE MASONRY PLATES. FOR EPOXY COATING, SEE SPECIAL PROVISIONS.

SHOTCRETE REPAIRS MAYBE SUBSTITUTED IN LIEU OF CONCRETE REPAIRS WITH THE APPROVAL OF THE ENGINEER.

FOR CAP AND COLUMN REPAIRS, SEE "TYPICAL CAP AND COLUMN REPAIR DETAILS" SHEET.

FOR SHOTCRETE REPAIRS, SEE SPECIAL PROVISIONS.

FOR CONCRETE REPAIRS, SEE SPECIAL PROVISIONS.

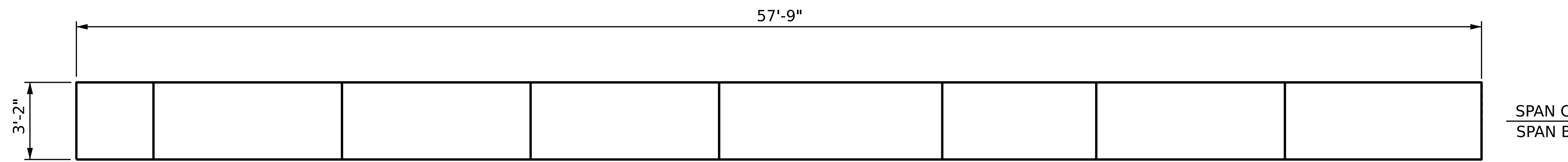

**PLAN - TOP OF CAP**

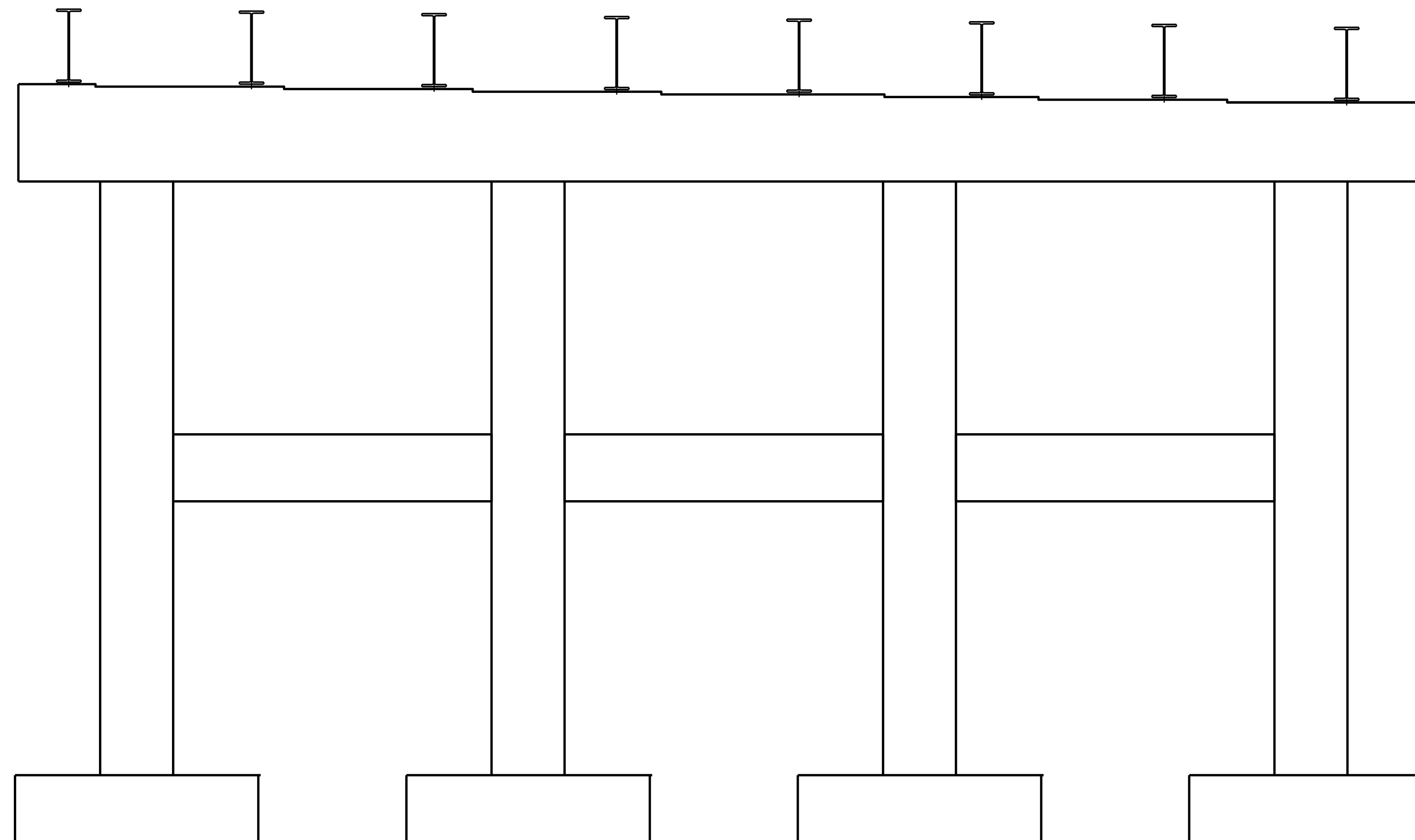

**ELEVATION**

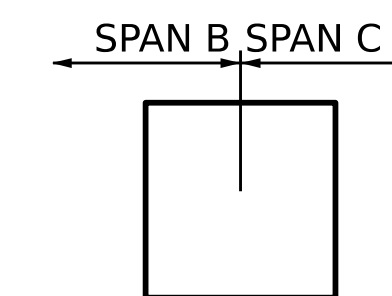

**END VIEW**

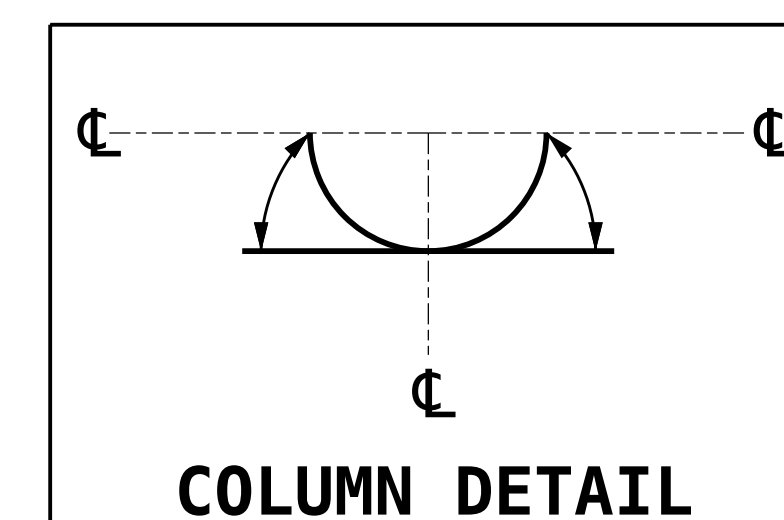

**COLUMN DETAIL**

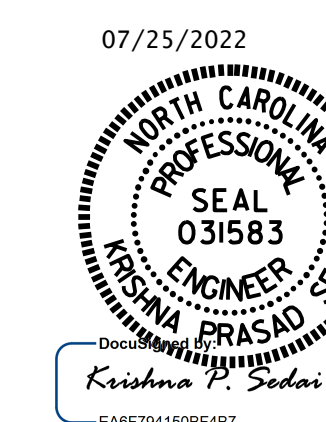

PROJECT NO. **I-5950**  
**DAVIDSON** COUNTY  
 BRIDGE NO. **280154**

SHEET 1 OF 2

STATE OF NORTH CAROLINA  
 DEPARTMENT OF TRANSPORTATION  
 RALEIGH

**SUBSTRUCTURE REPAIR  
 BENT 2  
 SPAN B FACE**

REVISIONS						SHEET NO. S6-12
NO.	BY:	DATE:	NO.	BY:	DATE:	
1			3			TOTAL SHEETS 15
2			4			

DOCUMENT NOT CONSIDERED  
 FINAL UNLESS ALL  
 SIGNATURES COMPLETED

DRAWN BY : S. AGUILAR HERNANDEZ DATE : 07/2020  
 CHECKED BY : E. BAYISSA DATE : 04/2022  
 DESIGN ENGINEER OF RECORD: \_\_\_\_\_ DATE : \_\_\_\_\_



**PLAN - BOTTOM OF CAP**

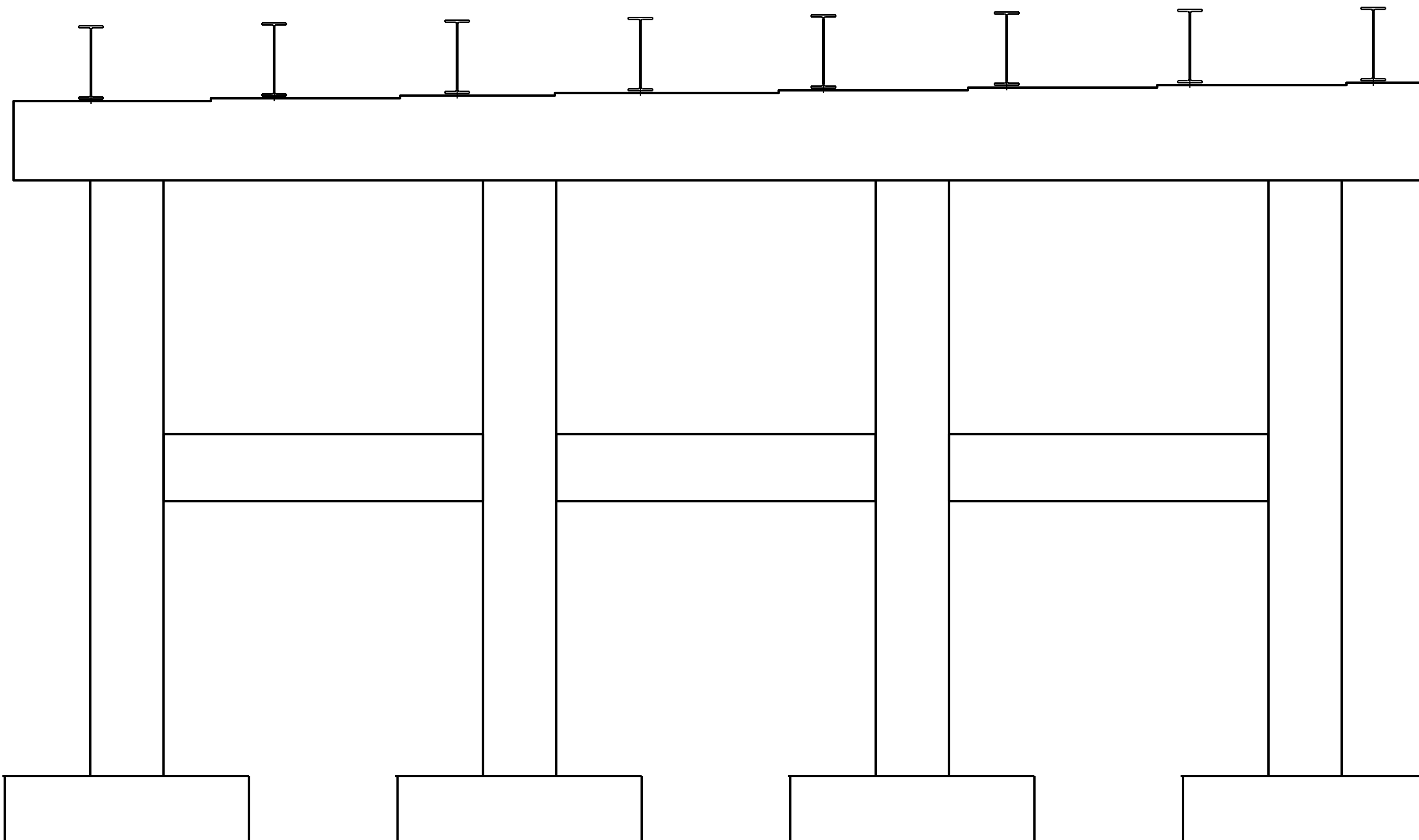

**ELEVATION**

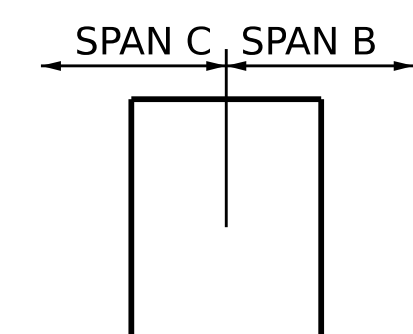

**END VIEW**

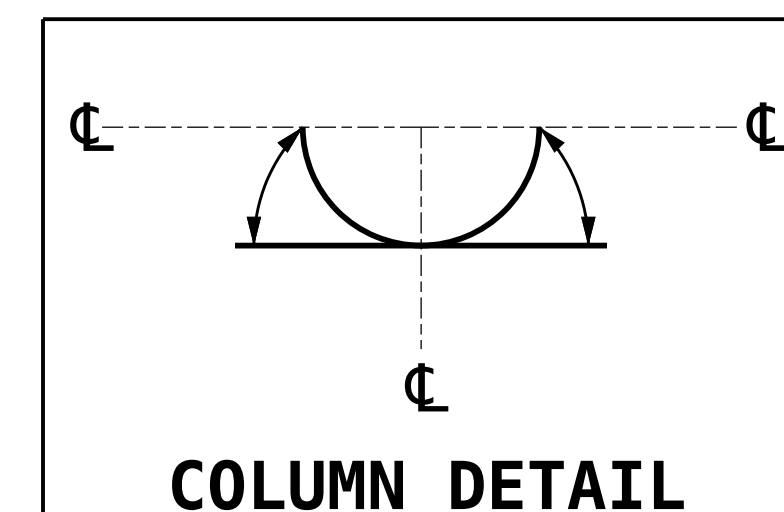

**COLUMN DETAIL**

**AS-BUILT REPAIR QUANTITY TABLE**

REPAIRS - BENT 2	QUANTITIES			
	ESTIMATE		ACTUAL	
SHOTCRETE REPAIRS	AREA SF	VOLUME CF	AREA SF	VOLUME CF
CAP	0.0	0.0		
COLUMN	0	0		
CONCRETE REPAIRS	AREA SF	VOLUME CF	AREA SF	VOLUME CF
CAP	0	0		
COLUMN	0	0		
EPOXY RESIN INJECTION		LINEAR FT		LINEAR FT
CAP		0		
COLUMN		0		

VALUES IN CHART REPRESENT ESTIMATED REPAIR TOTALS AFTER REMOVAL OF UNSOUND CONCRETE, MIN. OF 1" BEHIND REBAR AND MIN. 2" CLEAR TO SAWCUT. SEE REPAIR DETAILS.

**NOTES**



REPAIR LOCATIONS AND ESTIMATE OF QUANTITIES ARE GIVEN BASED ON THE BEST INFORMATION AVAILABLE. IF ADDITIONAL REPAIRS NOT SHOWN ON THE DRAWINGS ARE DEEMED NECESSARY BY THE ENGINEER, THE ENGINEER SHALL NOTE ON THE DRAWINGS THE APPROXIMATE LOCATION AND DESCRIPTION OF THE REPAIRS AND ENTER THE ACTUAL QUANTITIES INTO THE AS-BUILT REPAIR QUANTITY TABLE.

SHOTCRETE REPAIRS MAYBE SUBSTITUTED IN LIEU OF CONCRETE REPAIRS WITH THE APPROVAL OF THE ENGINEER.

FOR CAP AND COLUMN REPAIRS, SEE "TYPICAL CAP AND COLUMN REPAIR DETAILS" SHEET.

FOR SHOTCRETE REPAIRS, SEE SPECIAL PROVISIONS.

FOR CONCRETE REPAIRS, SEE SPECIAL PROVISIONS.

-  SHOTCRETE REPAIR AREA
-  CONCRETE REPAIR AREA
-  EPOXY RESIN INJECTION

PROJECT NO. **I-5950**

**DAVIDSON** COUNTY

BRIDGE NO. **280154**

SHEET 2 OF 2

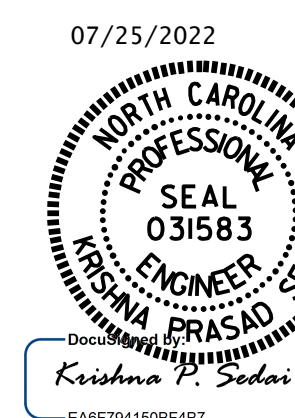

STATE OF NORTH CAROLINA  
DEPARTMENT OF TRANSPORTATION  
RALEIGH

**SUBSTRUCTURE REPAIR  
BENT 2  
SPAN C FACE**

REVISIONS					SHEET NO.
NO.	BY:	DATE:	NO.	BY:	DATE:
1			3		
2			4		

DOCUMENT NOT CONSIDERED  
FINAL UNLESS ALL  
SIGNATURES COMPLETED

DRAWN BY : **S. AGUILAR HERNANDEZ** DATE : **07/2020**  
CHECKED BY : **E. BAYISSA** DATE : **04/2022**  
DESIGN ENGINEER OF RECORD: \_\_\_\_\_ DATE : \_\_\_\_\_



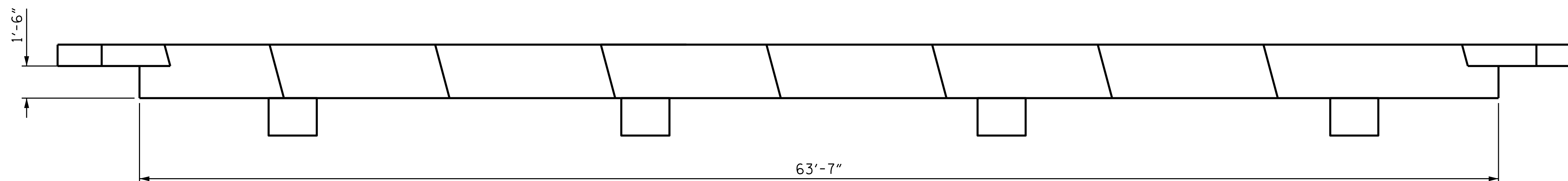



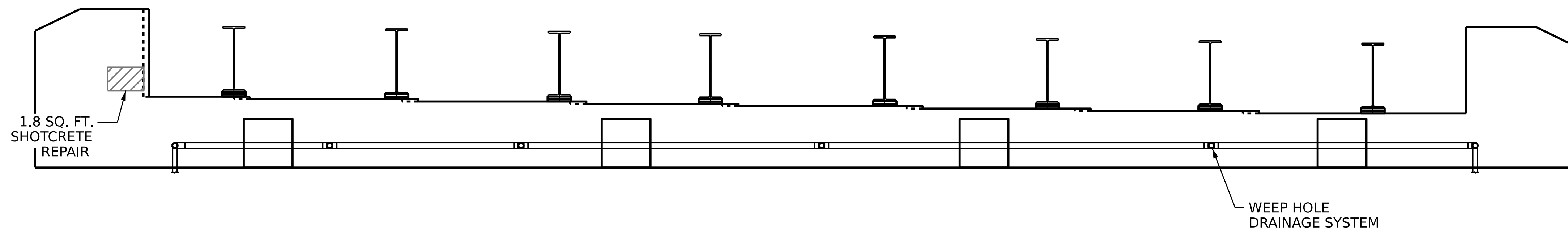

**PLAN**

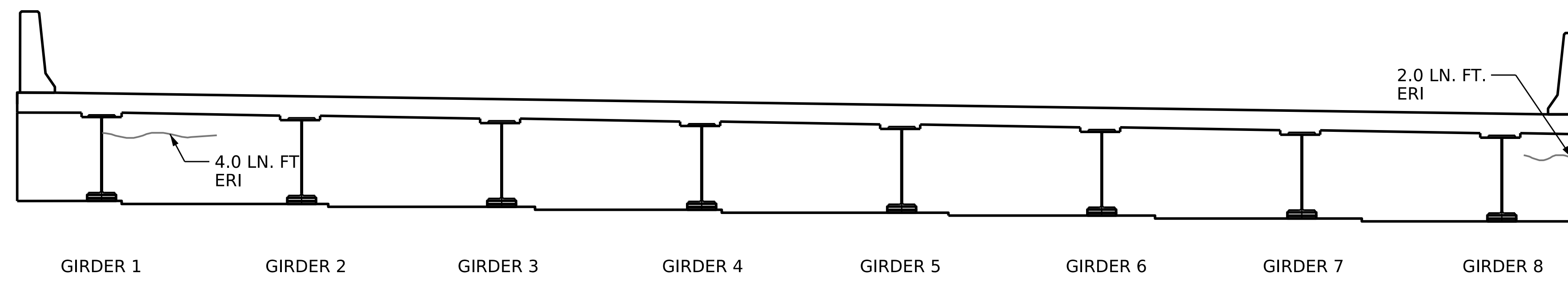

**ELEVATION**



**TYPICAL SECTION**

-  SHOTCRETE REPAIR AREA
-  CONCRETE REPAIR AREA
-  EPOXY RESIN INJECTION

AS-BUILT REPAIR QUANTITY TABLE				
REPAIRS - END BENT 2	QUANTITIES			
	ESTIMATE		ACTUAL	
SHOTCRETE REPAIRS	AREA SF	VOLUME CF	AREA SF	VOLUME CF
CAP	0	0		
CURTAIN WALL	0	0		
WINGWALL	1.8	0.9		
CONCRETE REPAIRS	AREA SF	VOLUME CF	AREA SF	VOLUME CF
CAP	0	0		
CURTAIN WALL	0	0		
WINGWALL				
EPOXY RESIN INJECTION		LINEAR FT		LINEAR FT
CAP		0		
CURTAIN WALL		6.0		
WINGWALL				
EPOXY COATING		AREA SF		AREA SF
CAP		95.4		
CURTAIN WALL		254.5		

VALUES IN CHART REPRESENT ESTIMATED REPAIR TOTALS AFTER REMOVAL OF UNSOUND CONCRETE, MIN. OF 1" BEHIND REBAR AND MIN. 2" CLEAR TO SAWCUT. SEE REPAIR DETAILS.

**NOTES**

REPAIR LOCATIONS AND ESTIMATE OF QUANTITIES ARE GIVEN BASED ON THE BEST INFORMATION AVAILABLE. IF ADDITIONAL REPAIRS NOT SHOWN ON THE DRAWINGS ARE DEEMED NECESSARY BY THE ENGINEER, THE ENGINEER SHALL NOTE ON THE DRAWINGS THE APPROXIMATE LOCATION AND DESCRIPTION OF THE REPAIRS AND ENTER THE ACTUAL QUANTITIES INTO THE AS-BUILT REPAIR QUANTITY TABLE.

CLEAN AND REMOVE DEBRIS FROM THE TOP OF THE CAP AND APPLY EPOXY PROTECTIVE COATING. EPOXY COATING SHALL BE APPLIED TO THE TOP SURFACE OF THE CAP. THE CONTRACTOR SHALL NOT COAT THE AREA OF THE CAP BENEATH THE MASONRY PLATES. FOR EPOXY COATING, SEE SPECIAL PROVISIONS.

SHOTCRETE REPAIRS MAYBE SUBSTITUTED IN LIEU OF CONCRETE REPAIRS WITH THE APPROVAL OF THE ENGINEER.

FOR CAP AND COLUMN REPAIRS, SEE "TYPICAL CAP AND COLUMN REPAIR DETAILS" SHEET.

FOR SHOTCRETE REPAIRS, SEE SPECIAL PROVISIONS.

FOR CONCRETE REPAIRS, SEE SPECIAL PROVISIONS.

PROJECT NO. **I-5950**  
**DAVIDSON** COUNTY  
 BRIDGE NO. **280154**

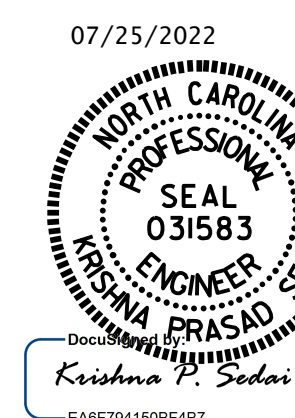

STATE OF NORTH CAROLINA  
 DEPARTMENT OF TRANSPORTATION  
 RALEIGH  
**SUBSTRUCTURE REPAIR  
 END BENT 2**

DRAWN BY : S. AGUILAR HERNANDEZ DATE : 07/2020  
 CHECKED BY : E. BAYISSA DATE : \_\_\_\_\_  
 DESIGN ENGINEER OF RECORD: \_\_\_\_\_ DATE : \_\_\_\_\_

DOCUMENT NOT CONSIDERED  
 FINAL UNLESS ALL  
 SIGNATURES COMPLETED

REVISIONS						SHEET NO. S6-14
NO.	BY:	DATE:	NO.	BY:	DATE:	
1			3			TOTAL SHEETS 15
2			4			

**NOTE:**  
FOR CLASS B RIP RAP, SEE STANDARD SPECIFICATIONS  
FOR ROADS AND STRUCTURES, 2018

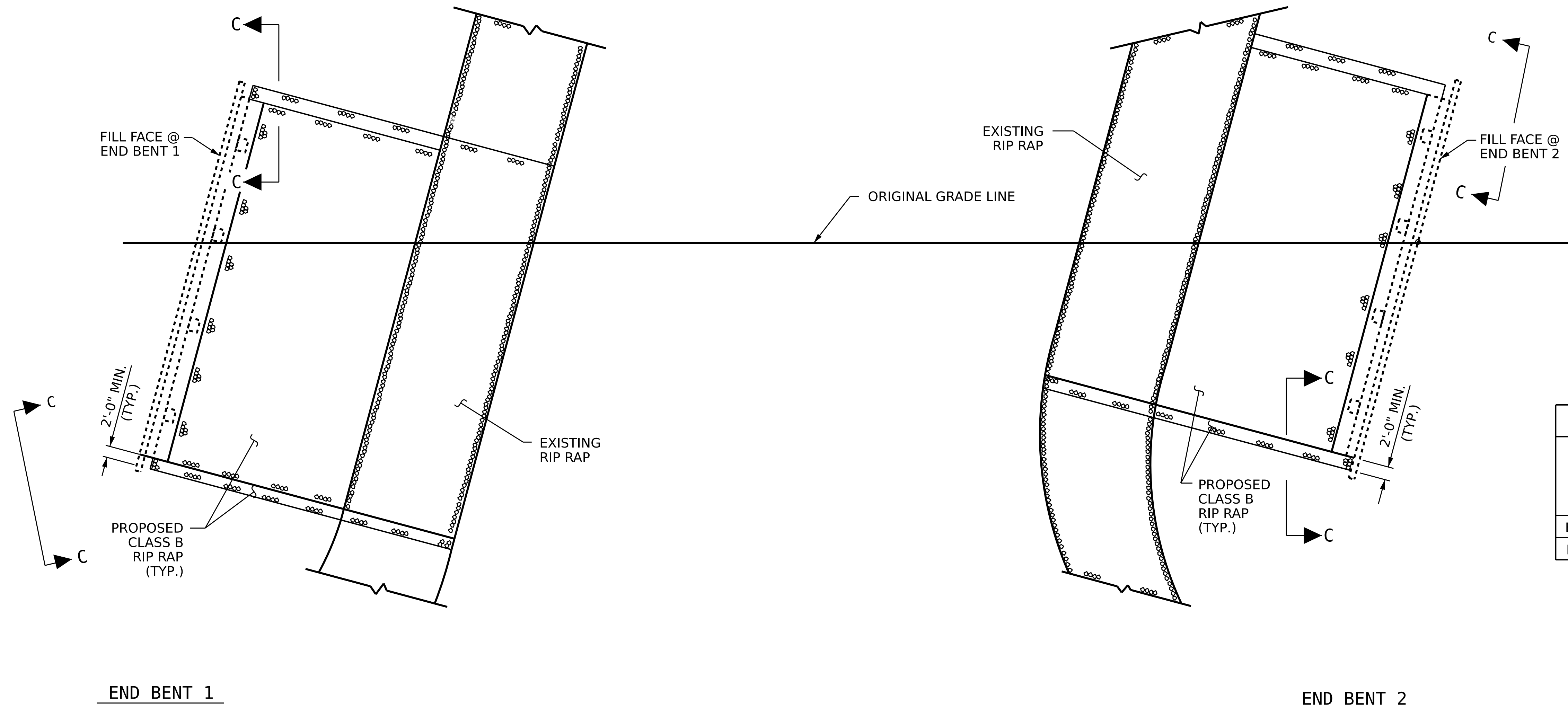

ESTIMATED QUANTITIES		
BRIDGE NO. 280154	RIP RAP CLASS B (2'-0" THICK)	GEOTEXTILE FOR DRAINAGE
	TONS	SQUARE YARDS
END BENT 1	290	322
END BENT 2	295	328

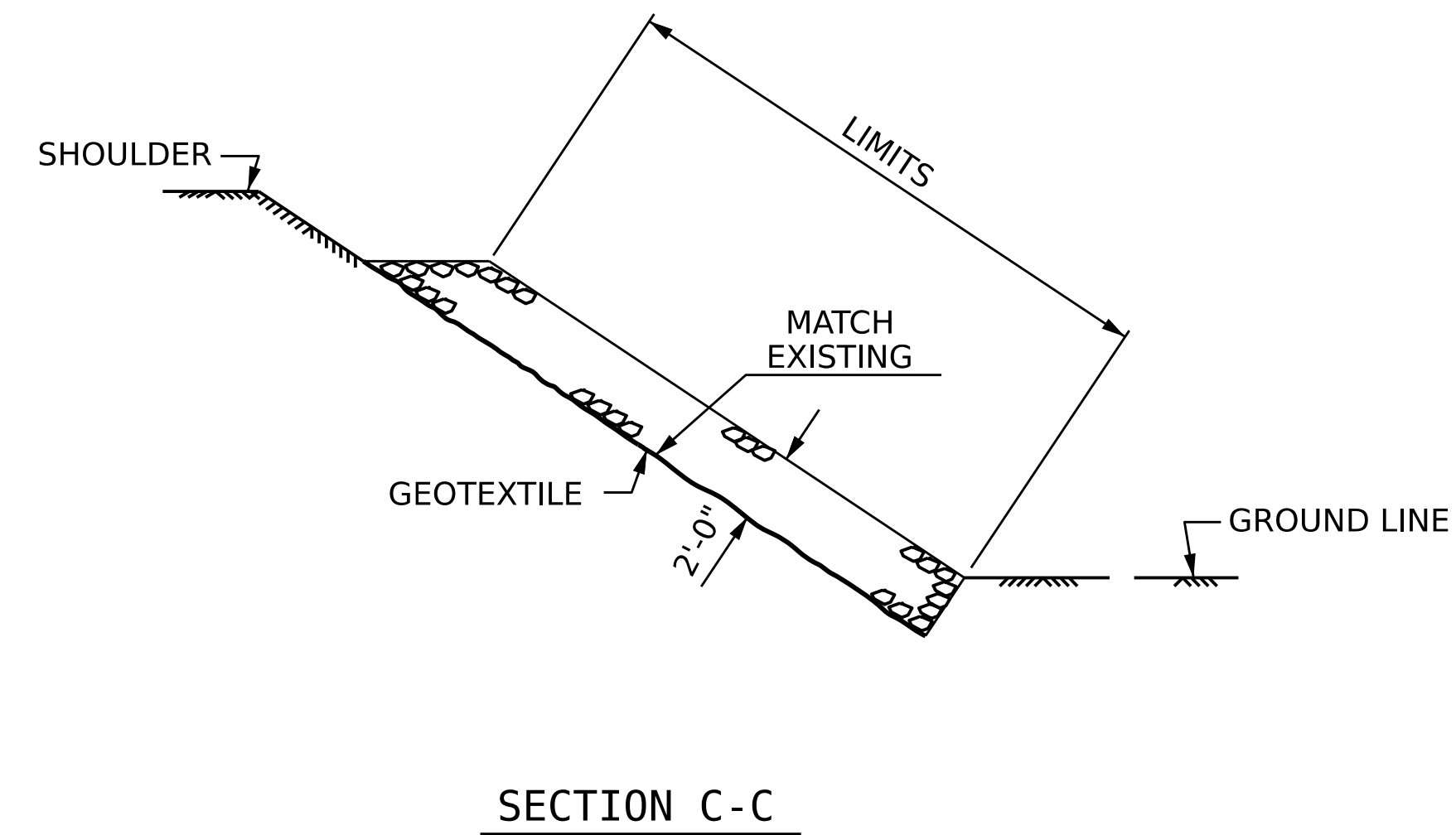
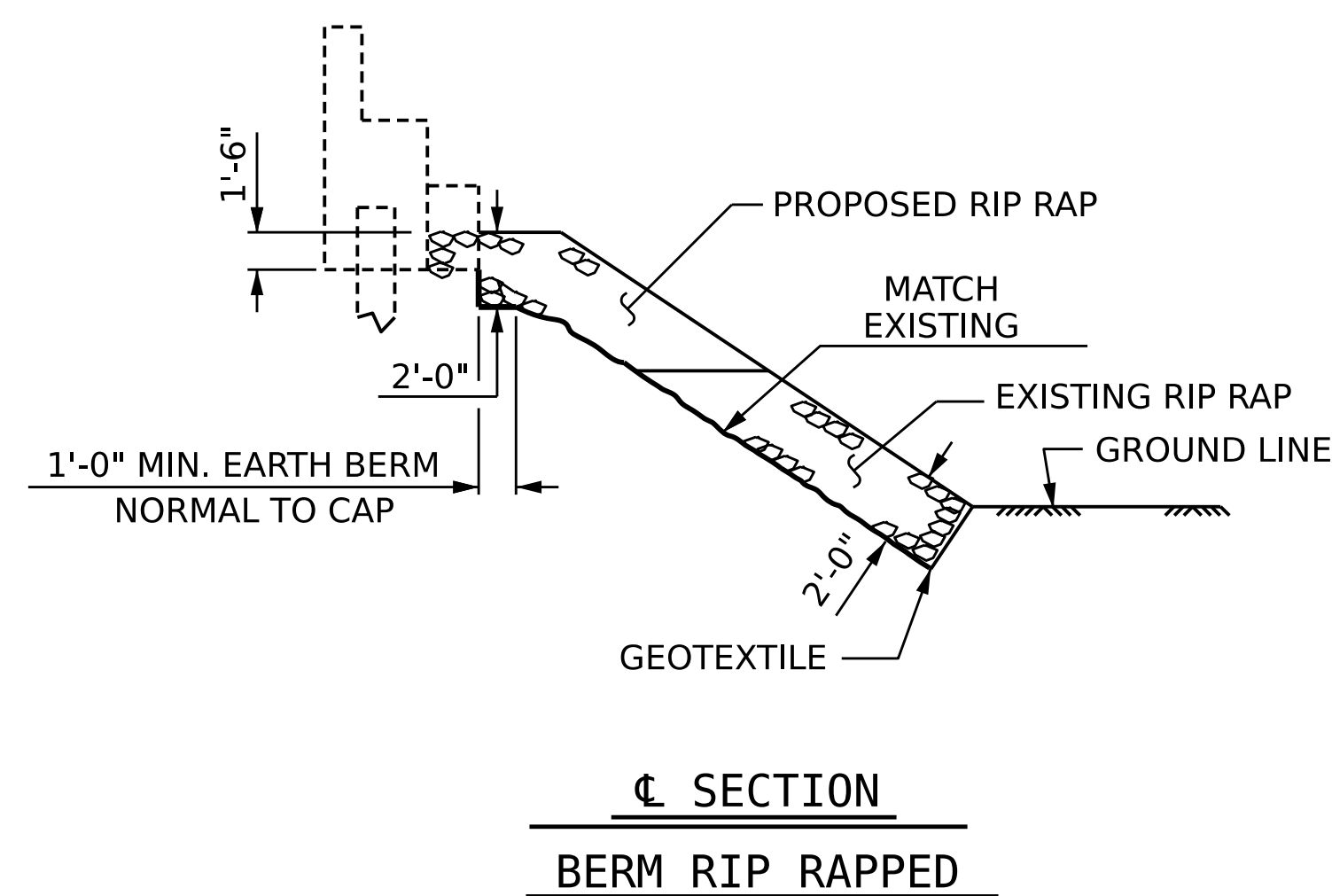

PROJECT NO. **I-5950**  
**DAVIDSON** COUNTY  
BRIDGE NO. **280154**

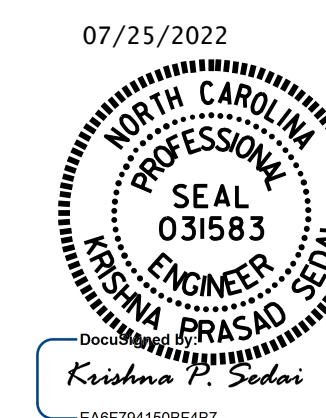

STATE OF NORTH CAROLINA  
DEPARTMENT OF TRANSPORTATION  
RALEIGH

**CLASS B  
RIP RAP DETAILS**

DOCUMENT NOT CONSIDERED  
FINAL UNLESS ALL  
SIGNATURES COMPLETED

REVISIONS						SHEET NO.
NO.	BY:	DATE:	NO.	BY:	DATE:	S6-15
1			3			TOTAL SHEETS
2			4			15

DRAWN BY : E. BAYISSA DATE : 05/2022  
CHECKED BY : K. SEDAI DATE : 05/2022

**NOTES**

GENERAL DRAWING INFORMATION IS TAKEN FROM THE ORIGINAL PLANS AND THE ROUTINE INSPECTION REPORT DATED 5/04/2022.  
BRIDGE ORIENTATION CONFORMS TO THE EXISTING BRIDGE PLANS/ROUTINE INSPECTION.

**SCOPE OF WORK**

- PARTIALLY REMOVE TOP OF BRIDGE DECK CONCRETE BY SCARIFICATION AND SHOTBLASTING METHODS.
- OVERLAY PREPARED TOP OF BRIDGE DECK WITH POLYMER CONCRETE (PC).
- REMOVE EXISTING JOINT MATERIAL AND INSTALL FOAM JOINTS.
- GROOVE PC BRIDGE DECK.
- EPOXY RESIN INJECTION OF CONCRETE CRACKS.
- REMOVE DEBRIS FROM TOP OF EXISTING END BENT CAPS, AND APPLY EPOXY COATING.
- PROPERLY PREPARE SPALLED AREAS IN EXISTING END BENTS AND BENTS, AND PERFORM SHOTCRETE AND CONCRETE REPAIRS.
- SURFACE PREPARATION AND CLEANING & PAINTING OF EXISTING BEARINGS AT END BENTS.
- PLACE GEOTEXTILE AND RIP RAP.

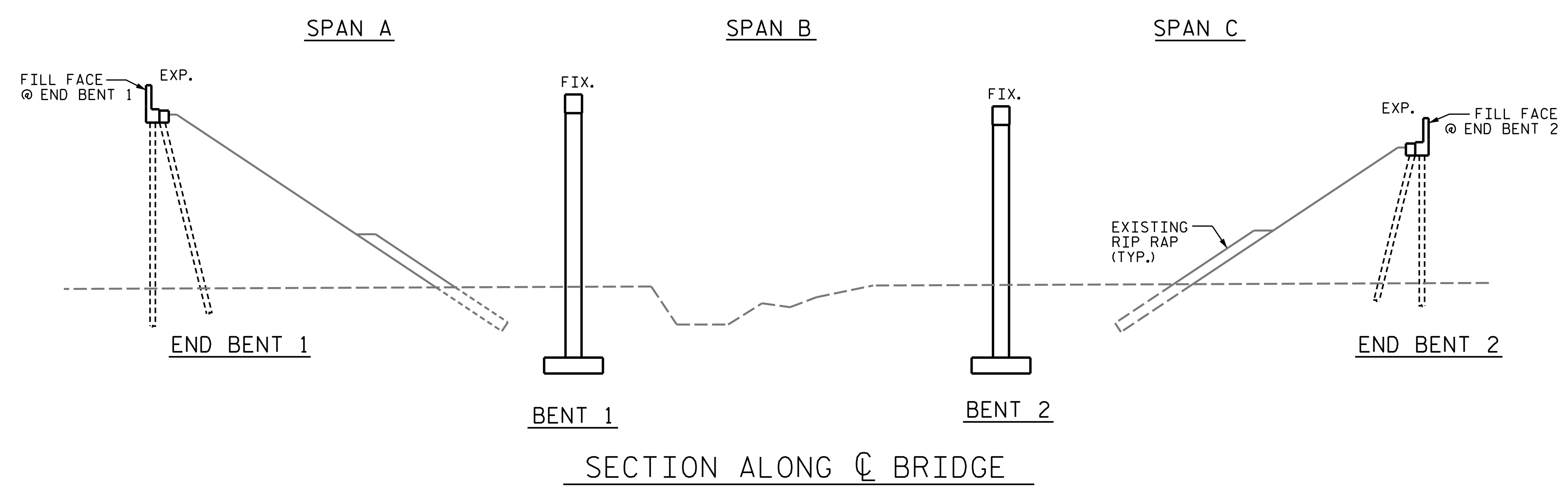

SECTION ALONG C BRIDGE

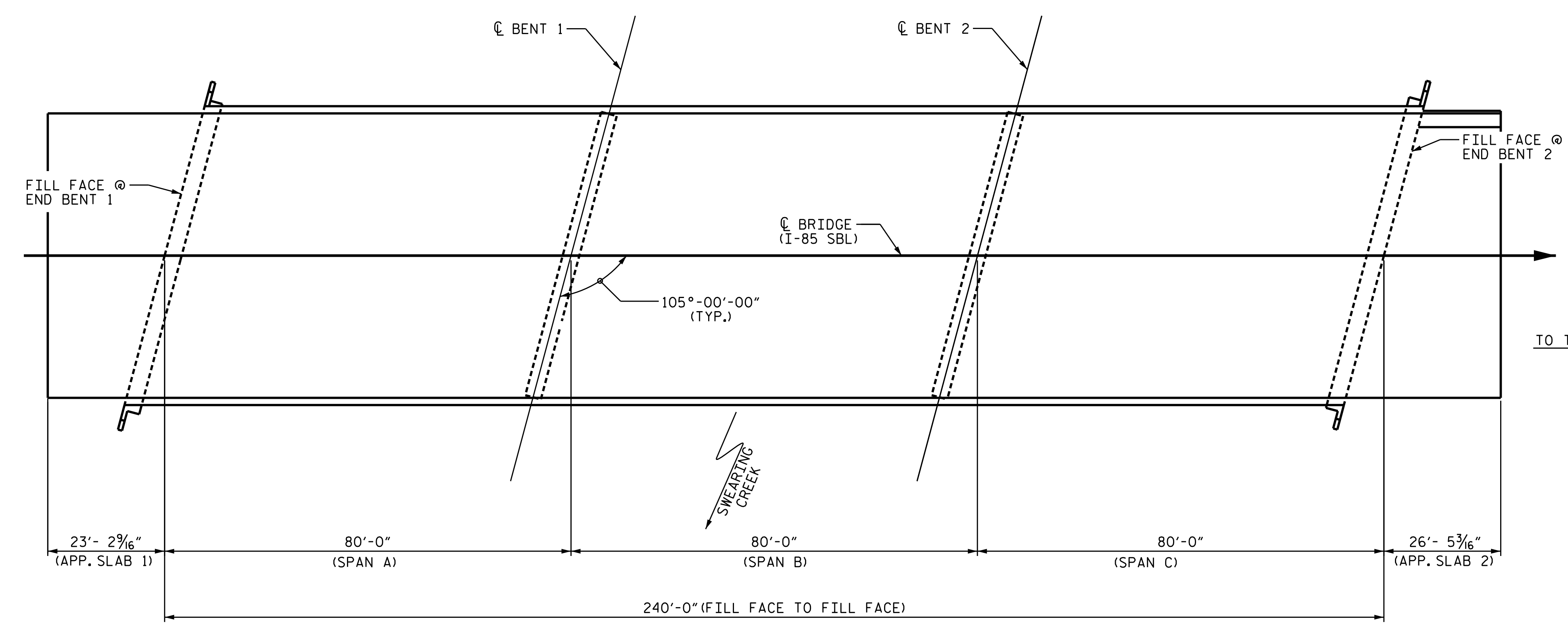

PLAN

I HEREBY CERTIFY THAT THIS STRUCTURE WAS REHABILITATED ACCORDING TO THESE PLANS OR AS NOTED HEREIN.  
RESIDENT ENGINEER \_\_\_\_\_ DATE \_\_\_\_\_

PROJECT NO. I-5950  
DAVIDSON COUNTY  
BRIDGE NO. 280157

SHEET 1 OF 2

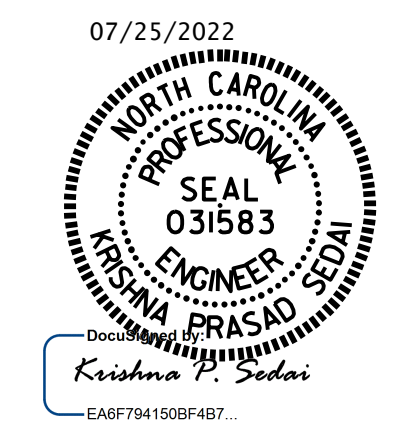
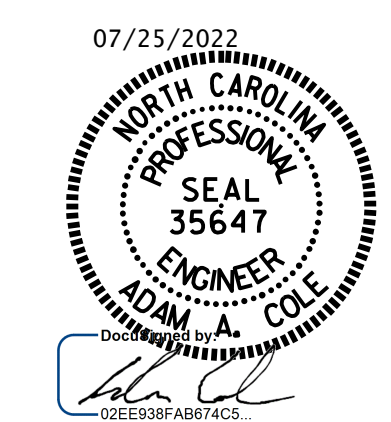

STATE OF NORTH CAROLINA  
DEPARTMENT OF TRANSPORTATION  
RALEIGH  
GENERAL DRAWING  
FOR BRIDGE ON I-85 SBL  
OVER SWEARING CREEK

DRAWN BY : K. PUROHIT DATE : 09/2020  
CHECKED BY : A. SORSENGINH DATE : 09/2021

DOCUMENT NOT CONSIDERED  
FINAL UNLESS ALL  
SIGNATURES COMPLETED

REVISIONS						SHEET NO.
NO.	BY:	DATE:	NO.	BY:	DATE:	S7-01
1			3			TOTAL SHEETS
2			4			15