

T.I.P.: R-3300B

CONTRACT NO.:

9/13/2021
Us:\Traffic\Signing\CADD\pmp\plan_sheets\R-3300B_pmp_01.dgn
angood



**STATE OF NORTH CAROLINA
DEPARTMENT OF TRANSPORTATION**

**PAVEMENT MARKING PLAN
PENDER COUNTY**

LOCATION: NC 417 (HAMPSTEAD BYPASS) FROM SOUTH OF NC 210

TO US-17 NORTH OF HAMPSTEAD

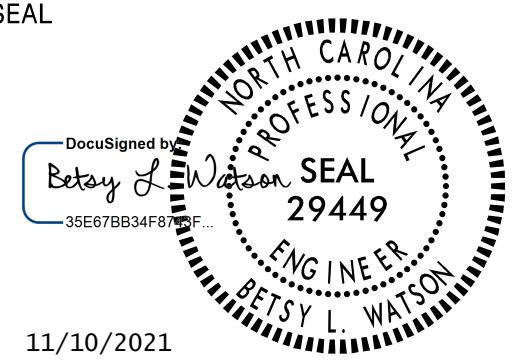
TYPE OF WORK: GRADING, DRAINAGE, PAVING, STRUCTURES, AND CULVERTS

TIP NO. R-3300B	SHEET NO. PMP-1
APPROVED: _____	
DATE: _____	
SEAL	
	
11/10/2021	
DOCUMENT NOT CONSIDERED FINAL UNLESS ALL SIGNATURES COMPLETED	
	

ROADWAY STANDARD DRAWINGS

THE FOLLOWING ROADWAY STANDARDS AS APPEAR IN "ROADWAY STANDARD DRAWINGS" - PROJECT SERVICES UNIT - N.C. DEPARTMENT OF TRANSPORTATION - RALEIGH, N.C., DATED JANUARY 2018 ARE APPLICABLE TO THIS PROJECT AND BY REFERENCE HEREBY ARE CONSIDERED A PART OF THESE PLANS:

STD. NO.	TITLE
1205.01	PAVEMENT MARKINGS - LINE TYPES & OFFSETS
1205.02	PAVEMENT MARKINGS - 2 LANE & MULTILANE ROADWAYS
1205.03	PAVEMENT MARKINGS - EXIT & ENTRANCE RAMPS
1205.04	PAVEMENT MARKINGS - INTERSECTIONS
1205.05	PAVEMENT MARKINGS - TURN LANES
1205.06	PAVEMENT MARKINGS - LANE DROPS
1205.07	PAVEMENT MARKINGS - PEDESTRIAN CROSSWALKS
1205.08	PAVEMENT MARKINGS - SYMBOLS & WORD MESSAGES
1205.09	PAVEMENT MARKINGS - PAINTED ISLANDS
1205.10	PAVEMENT MARKINGS - SCHOOLS
1205.12	PAVEMENT MARKINGS - BRIDGES
1205.13	PAVEMENT MARKINGS - LANE REDUCTIONS
1250.01	RAISED PAVEMENT MARKERS - INSTALLATION SPACING
1251.01	RAISED PAVEMENT MARKERS - PERMANENT & TEMPORARY
1253.01	RAISED PAVEMENT MARKERS - SNOWPLOWABLE
1261.01	GUARDRAIL & BARRIER DELINEATORS - INSTALLATION SPACING
1261.02	GUARDRAIL & BARRIER DELINEATORS - TYPES & MOUNTING
1262.01	GUARDRAIL END DELINEATION
1266.01	RAISED PAVEMENT MARKERS - TUBULAR MARKERS
1267.01	FLEXIBLE DELINEATORS - INSTALLATION
1267.02	FLEXIBLE DELINEATORS - SPACING TABLES
1267.03	FLEXIBLE DELINEATORS - INTERCHANGE PLACEMENT

GENERAL NOTES

THE FOLLOWING GENERAL NOTES APPLY AT ALL TIMES FOR THE DURATION OF THE CONSTRUCTION PROJECT, EXCEPT WHEN OTHERWISE NOTED IN THE PLAN, OR DIRECTED BY THE ENGINEER.

- A) INSTALL PAVEMENT MARKINGS AND PAVEMENT MARKERS ON THE FINAL SURFACE AS FOLLOWS:

ROAD NAME	MARKING	MARKER
ALL ROADS	THERMOPLASTIC	SNOWPLOWABLE RAISED
BRIDGE DECKS	POLYUREA	PERMANENT RAISED
- B) TIE PROPOSED PAVEMENT MARKING LINES TO EXISTING PAVEMENT MARKING LINES.
- C) REMOVE/REPLACE ANY CONFLICTING/DAMAGED PAVEMENT MARKINGS AND MARKERS.
- D) PASSING ZONES WILL BE DETERMINED IN THE FIELD AND MUST BE APPROVED BY THE ENGINEER.
- E) STOP BAR LOCATION AT NON-SIGNALIZED INTERSECTIONS MAY BE ADJUSTED AS DIRECTED BY THE ENGINEER.
- F) UNLESS OTHERWISE SPECIFIED, HEATED-IN-PLACE THERMOPLASTIC MAY BE USED IN LIEU OF EXTRUDED THERMOPLASTIC FOR STOP BARS, SYMBOLS, CHARACTERS AND DIAGONALS.
- G) SEE ROADWAY PLANS FOR ALTERNATE CURB RAMPS.

FINAL PAVEMENT MARKING SCHEDULE

SYMBOL	DESCRIPTION	PAY ITEM
T1	WHITE EDGELINE	(4", 90 MIL) THERMOPLASTIC
T2	WHITE SOLID LANE LINE	(4", 90 MIL) THERMOPLASTIC
T3	10 FT. WHITE SKIP	(4", 90 MIL) THERMOPLASTIC
T4	3 FT.-9 FT./SP WHITE MINISKIP	(4", 90 MIL) THERMOPLASTIC
T5	2 FT.-6 FT./SP WHITE MINISKIP	(4", 90 MIL) THERMOPLASTIC
T10	YELLOW EDGELINE	(4", 90 MIL) THERMOPLASTIC
T13	YELLOW DOUBLE CENTER	(4", 90 MIL) THERMOPLASTIC
T14	2 FT.-6 FT./SP YELLOW MINISKIP	(4", 90 MIL) THERMOPLASTIC
T20	WHITE EDGELINE	(6", 90 MIL) THERMOPLASTIC
T21	WHITE SOLID LANE LINE	(6", 90 MIL) THERMOPLASTIC
T22	10 FT. WHITE SKIP	(6", 90 MIL) THERMOPLASTIC
T23	3 FT.-9 FT./SP WHITE MINISKIP	(6", 90 MIL) THERMOPLASTIC
T24	2 FT.-6 FT/SP WHITE MINISKIP	(6", 90 MIL) THERMOPLASTIC
T30	YELLOW EDGELINE	(6", 90 MIL) THERMOPLASTIC
T33	YELLOW DOUBLE CENTER	(6", 90 MIL) THERMOPLASTIC
T34	2 FT.-6 FT./SP YELLOW MINISKIP	(6", 90 MIL) THERMOPLASTIC
T40	WHITE GORELINE	(8", 90 MIL) THERMOPLASTIC
T41	WHITE DIAGONAL	(8", 90 MIL) THERMOPLASTIC
T43	WHITE SOLID LANE LINE	(8", 90 MIL) THERMOPLASTIC
T44	3 FT.-9 FT/SP WHITE MINISKIP	(8", 90 MIL) THERMOPLASTIC
T50	WHITE GORELINE	(12", 90 MIL) THERMOPLASTIC
T51	WHITE DIAGONAL	(12", 90 MIL) THERMOPLASTIC
T52	YELLOW DIAGONAL	(12", 90 MIL) THERMOPLASTIC
T53	WHITE SOLID LANE LINE	(12", 90 MIL) THERMOPLASTIC
T54	3 FT.-9 FT/SP WHITE MINISKIP	(12", 90 MIL) THERMOPLASTIC
T61	WHITE STOPBAR	(24", 90 MIL) THERMOPLASTIC
T62	WHITE CROSSWALK LINE	(24", 90 MIL) THERMOPLASTIC
T70	LEFT TURN ARROW	(90 MIL) THERMOPLASTIC
T71	RIGHT TURN ARROW	(90 MIL) THERMOPLASTIC
T72	STRAIGHT ARROW	(90 MIL) THERMOPLASTIC
T74	COMBO. RIGHT/STRAIGHT ARROW	(90 MIL) THERMOPLASTIC
T76	COMBO. LEFT/RIGHT/STRAIGHT ARROW	(90 MIL) THERMOPLASTIC
T77	U-TURN ARROW	(90 MIL) THERMOPLASTIC
T79	MERGE ARROW	(90 MIL) THERMOPLASTIC
T80	WRONG-WAY RAMP ARROW	(90 MIL) THERMOPLASTIC
T81	ELONGATED STRAIGHT ARROW	(90 MIL) THERMOPLASTIC
T100	ALPHANUMERIC CHAR.	(90 MIL) THERMOPLASTIC
V1	WHITE EDGELINE	(4", 20 MIL) POLYUREA
V2	WHITE SOLID LANE LINE	(4", 20 MIL) POLYUREA
V3	10 FT. WHITE SKIP	(4", 20 MIL) POLYUREA
V4	3 FT.-9 FT./SP WHITE MINISKIP	(4", 20 MIL) POLYUREA
V10	YELLOW EDGELINE	(4", 20 MIL) POLYUREA
V20	WHITE EDGELINE	(6", 20 MIL) POLYUREA
V22	10 FT WHITE SKIP	(6", 20 MIL) POLYUREA
V30	YELLOW EDGELINE	(6", 20 MIL) POLYUREA
MA	YELLOW & YELLOW, PERMANENT RAISED PAVEMENT MARKERS	
MB	CRYSTAL & RED, PERMANENT RAISED PAVEMENT MARKERS	
ME	YELLOW .& YELLOW, SNOWPLOWABLE PAVEMENT MARKERS	
MF	CRYSTAL & RED SNOWPLOWABLE PAVEMENT MARKERS	

INDEX

SHEET NO.	DESCRIPTION
PMP-1	PAVEMENT MARKING PLAN TITLE AND SCHEDULE SHEET
PMP-2-2B	REVISED PAVEMENT MARKING ROADWAY STANDARD DRAWING
PMP-3	CURB RAMP LOCATION INDEX
PMP-4-38	PAVEMENT MARKING DETAIL

PLAN REVIEWED BY: N.C.D.O.T. SIGNING AND DELINEATION UNIT

AYMAN ALQUDWAH, P.E. SIGNING & DELINEATION REGIONAL ENGINEER
MITCH EATON, P.E. SIGNING & DELINEATION PROJECT DESIGN ENGINEER

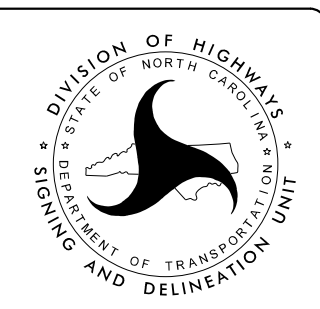

PLAN PREPARED BY:

JAY W. WOOLARD, P.E. SENIOR TRANSPORTATION ENGINEER
ANDREW N. GOOD TRANSPORTATION DESIGNER



Stantec Consulting Services Inc.
801 Jones Franklin Road
Suite 300
Raleigh, NC 27606
Tel. (919) 851-6866
Fax. (919) 851-7024
www.stantec.com
License No. F-6672



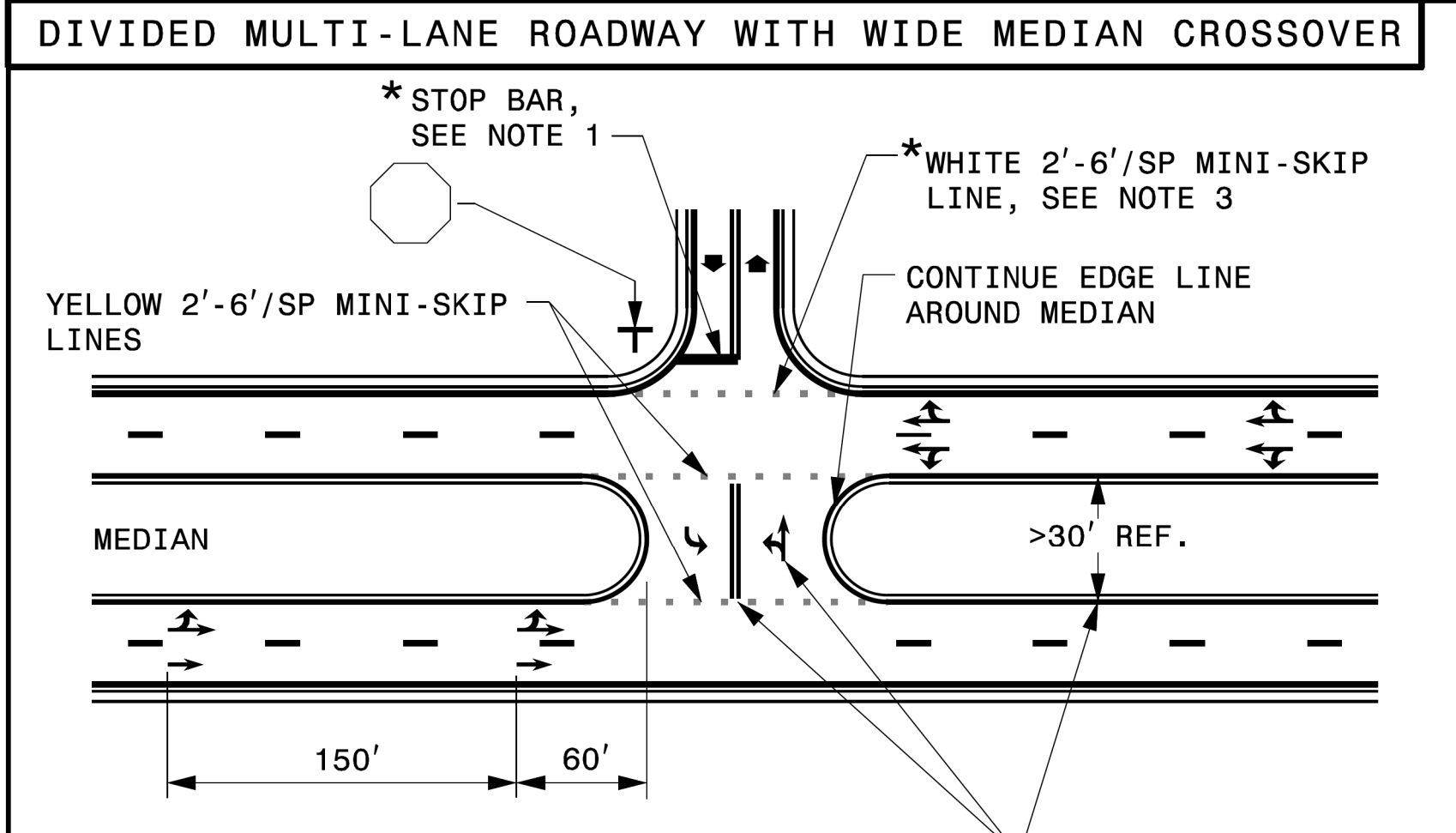
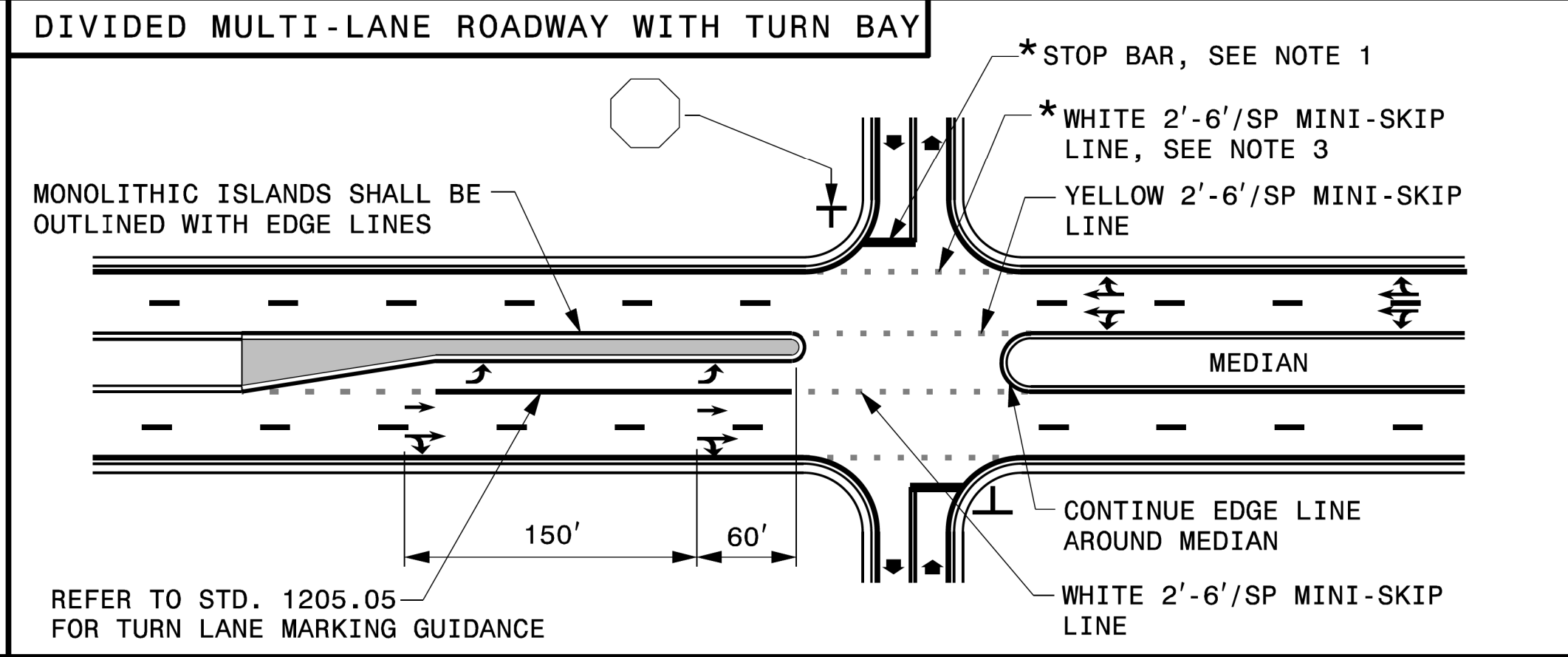
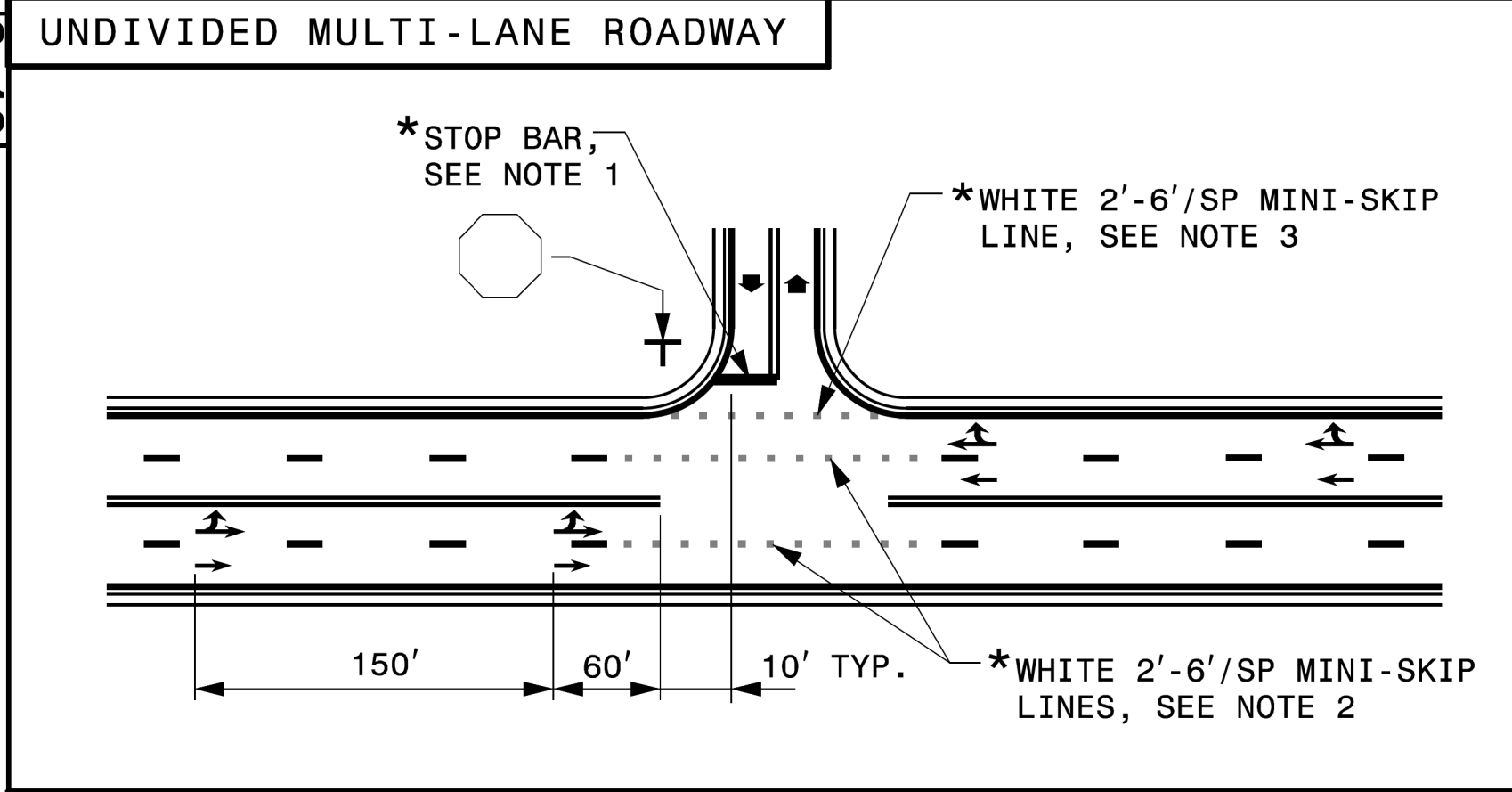
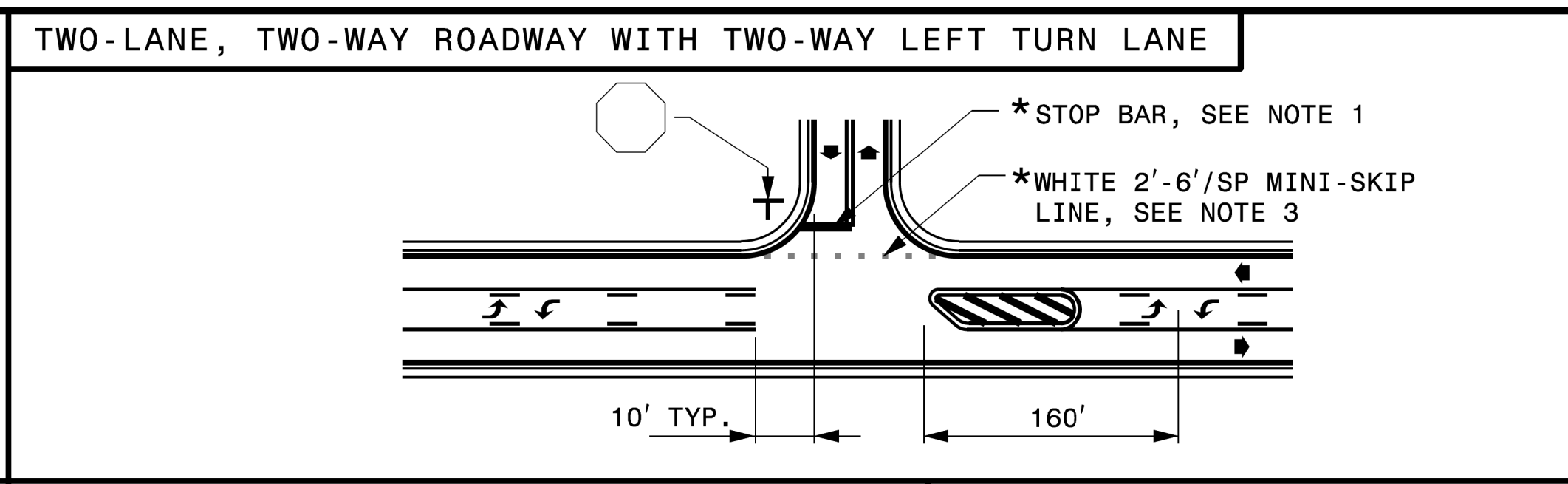
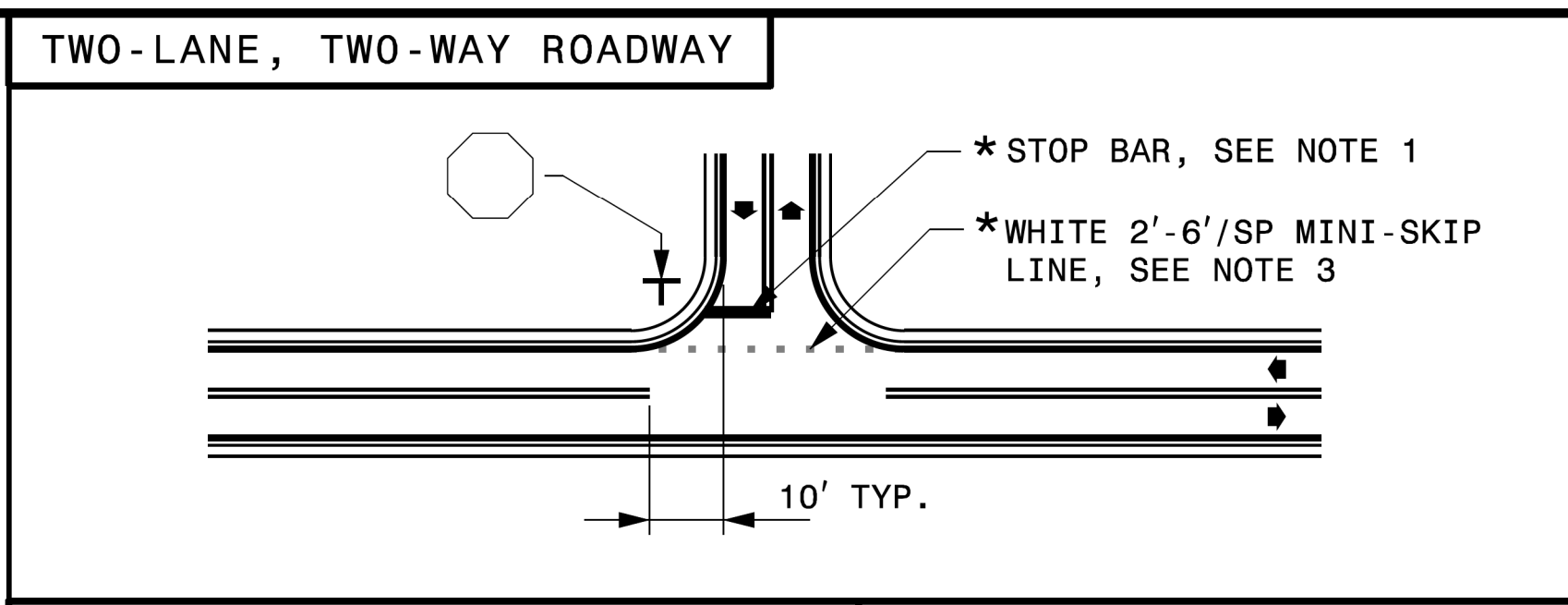

TIP NO.	SHEET NO.
DocuSigned by:	
<i>Matthew V. Springer</i>	
APPROVED:	6/19/2019
DATE:	02661200584403...
SEAL	
	

STATE OF NORTH CAROLINA
DEPT. OF TRANSPORTATION
DIVISION OF HIGHWAYS
RALEIGH, N.C.

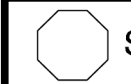

- GENERAL NOTES:**
- 1- PLACEMENT OF STOP BARS AT NON-SIGNALIZED INTERSECTIONS IS OPTIONAL AND USED WHERE IT IS IMPORTANT TO INDICATE THE POINT WHICH VEHICLES ARE REQUIRED TO STOP. PLACE STOP BARS NO LESS THAN 4 FEET AND NO MORE THAN 30 FEET FROM THE NEAREST EDGE OF THE INTERSECTING ROADWAY. USE 10 FEET AS THE TYPICAL SETBACK DISTANCE OR AS DIRECTED BY THE ENGINEER.
 - 2- MINI-SKIP LANE LINE EXTENSIONS SHOULD BE USED AT INTERSECTIONS THAT HAVE REDUCED VISIBILITY CONDITIONS SUCH AS OFFSET, SKEWED, OR CURVED ROADWAYS.
 - 3- MINI-SKIP EDGE LINE EXTENSIONS MAY BE PLACED THROUGH INTERSECTIONS AND MAJOR DRIVEWAYS.
 - 4- REFER TO ROADWAY STANDARD DRAWINGS 1205.01, 1205.02, 1205.05, 1205.08 AND 1205.09 FOR ADDITIONAL PAVEMENT MARKING GUIDANCE.

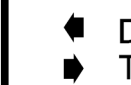
LEGEND

 STOP SIGN	 STATIONARY SIGN
 DIRECTION OF TRAFFIC FLOW	 PAVEMENT MARKING SYMBOLS
* OPTIONAL	

USE DOUBLE YELLOW CENTER LINE AND ARROW SYMBOLS IN MEDIAN CROSSOVER WHEN WIDTH OF MEDIAN EXCEEDS 30 FT, OTHERWISE THEY ARE NOT REQUIRED.

SHEET 2 OF 2
1205D04

SHEET 2 OF 2
1205D04

ENGLISH DETAIL DRAWING FOR
PAVEMENT MARKINGS
INTERSECTIONS

ENGLISH DETAIL DRAWING FOR
PAVEMENT MARKINGS
INTERSECTIONS

REVISED PAVEMENT MARKING ROADWAY STANDARD DRAWING

STATE OF
NORTH CAROLINA
DEPT. OF TRANSPORTATION
DIVISION OF HIGHWAYS
RALEIGH, N.C.

5-18

ENGLISH TYPICAL DRAWING FOR
PAVEMENT MARKINGS
HI-VISIBILITY CROSSWALKS
NO-TRACK MARKING GUIDANCE

SHEET 1 OF 1

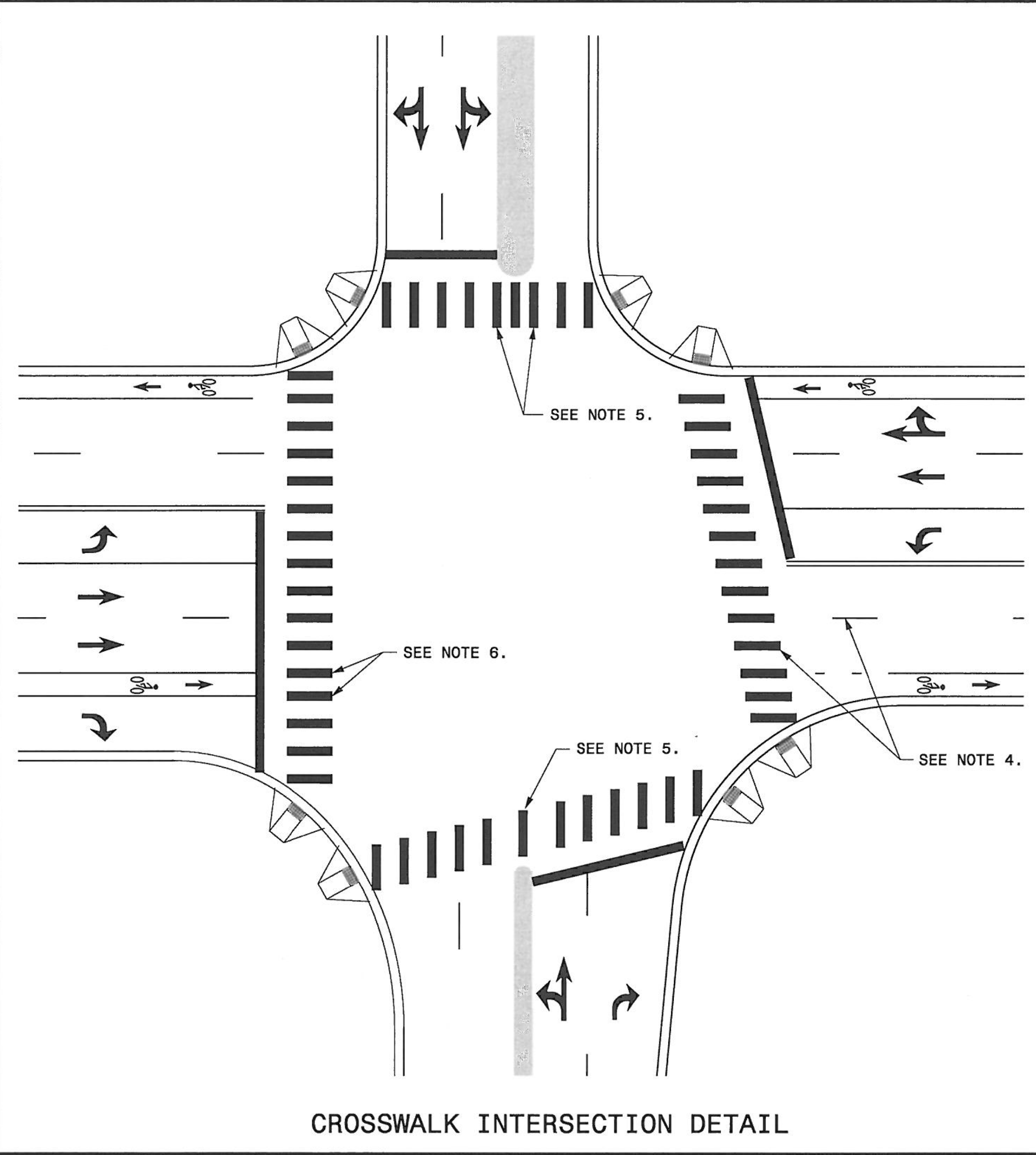

CROSSWALK INTERSECTION DETAIL

GENERAL NOTES:

- 1- THE GUIDANCE IN THIS DETAIL IS TO BE USED WHEN NO-TRACK SPACING OF HI-VISIBILITY MARKINGS IS REQUESTED.
- 2- USE THE GUIDANCE SHOWN ON THE ABOVE DETAILS IN CONJUNCTION WITH PAVEMENT MARKING GUIDANCE SHOWN ON ROADWAY STANDARD DRAWINGS 1205.01 AND 1205.07.
- 3- PLACE MARKINGS TO AVOID WHEELPATH OF VEHICLES. MARKINGS TYPICALLY WILL BE LOCATED CENTERED AT THE LANE LINES AND EDGE LINES WITH ONE ADDITIONAL MARKING CENTERED IN THE MIDDLE OF THE LANE. AT WIDE LANE WIDTHS DUE TO TAPERS AND LARGE RADII, LOCATE MARKINGS AT BEST SPACING TO AVOID WHEEL TRACKING. THE SPACE BETWEEN MARKINGS SHALL NOT BE LESS THAN 24 INCHES OR GREATER THAN 60 INCHES.

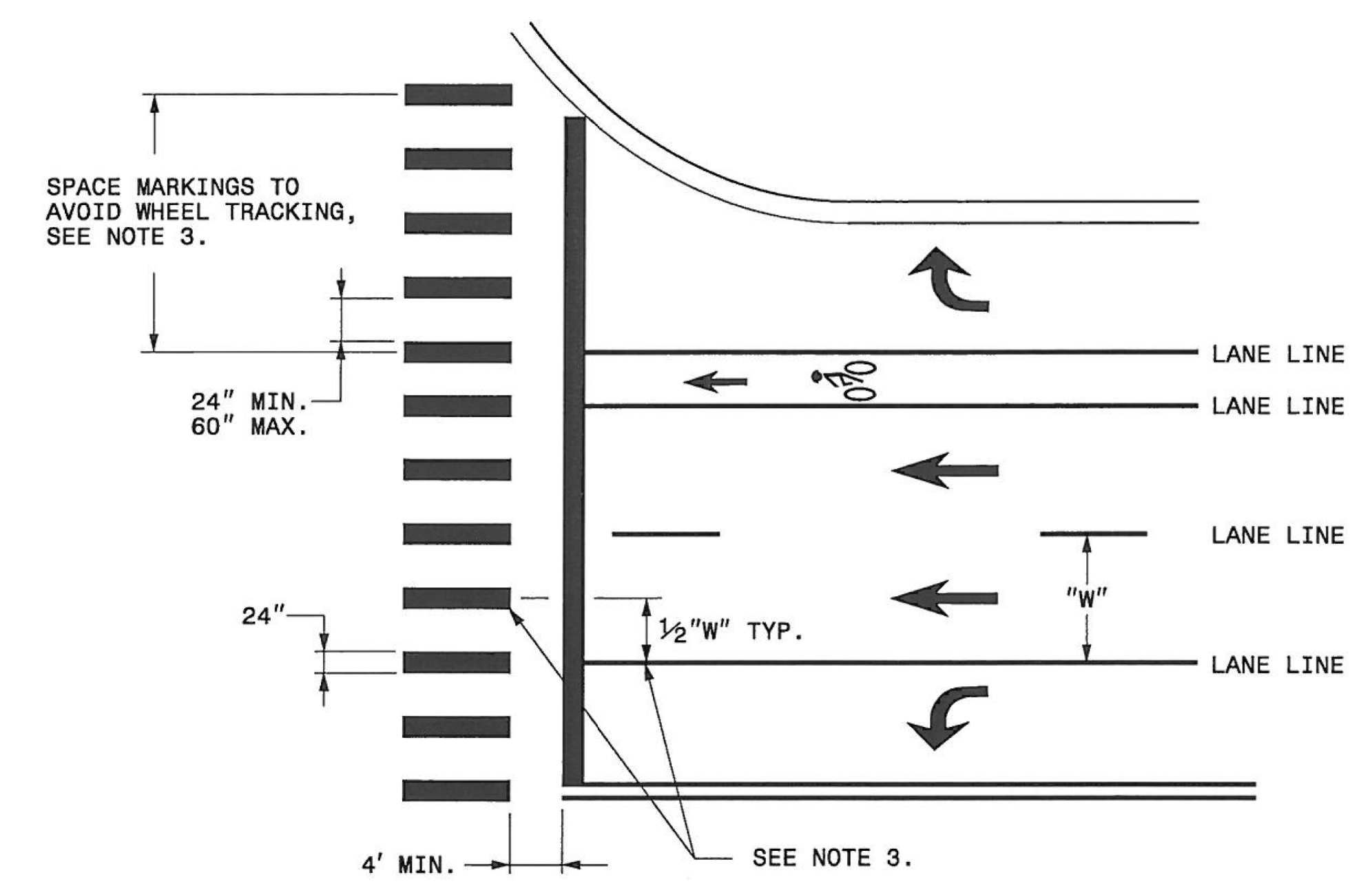

CROSSWALK MARKING DETAIL

- 4- WHERE THE CROSSWALK IS SKEWED TO THE LANE LINES, THE MARKINGS SHOULD BE PARALLEL TO THE LANE LINES.
- 5- PLACE MARKINGS ON BOTH EDGES OF THE NOSE OF A MEDIAN. FOR NARROW MEDIANS LESS THAN 4 FEET, A SINGLE MARKING MAY BE USED. FOR WIDE MEDIANS, INSTALL ADDITIONAL MARKINGS IN THE MEDIAN AREA. THE SPACE BETWEEN THE MARKINGS SHALL NOT TO BE LESS THAN 24 INCHES OR GREATER THAN 60 INCHES.
- 6- LOCATE MARKINGS CENTERED ON BICYCLE LANE LINES. MARKINGS SHALL NOT BE LOCATED IN THE CENTER OF THE BICYCLE PATH.

STATE OF
NORTH CAROLINA
DEPT. OF TRANSPORTATION
DIVISION OF HIGHWAYS
RALEIGH, N.C.

5-18

ENGLISH TYPICAL DRAWING FOR
PAVEMENT MARKINGS
HI-VISIBILITY CROSSWALKS
NO-TRACK MARKING GUIDANCE

SHEET 1 OF 1

STATE OF NORTH CAROLINA
DEPT. OF TRANSPORTATION
DIVISION OF HIGHWAYS
RALEIGH, N.C.

10-17

ENGLISH STANDARD DETAIL FOR
PAVEMENT MARKINGS
SIDE-BY-SIDE/ADJACENT ON/OFF RAMP
PAVEMENT MARKING LANE TREATMENT

SHEET 1 OF 1

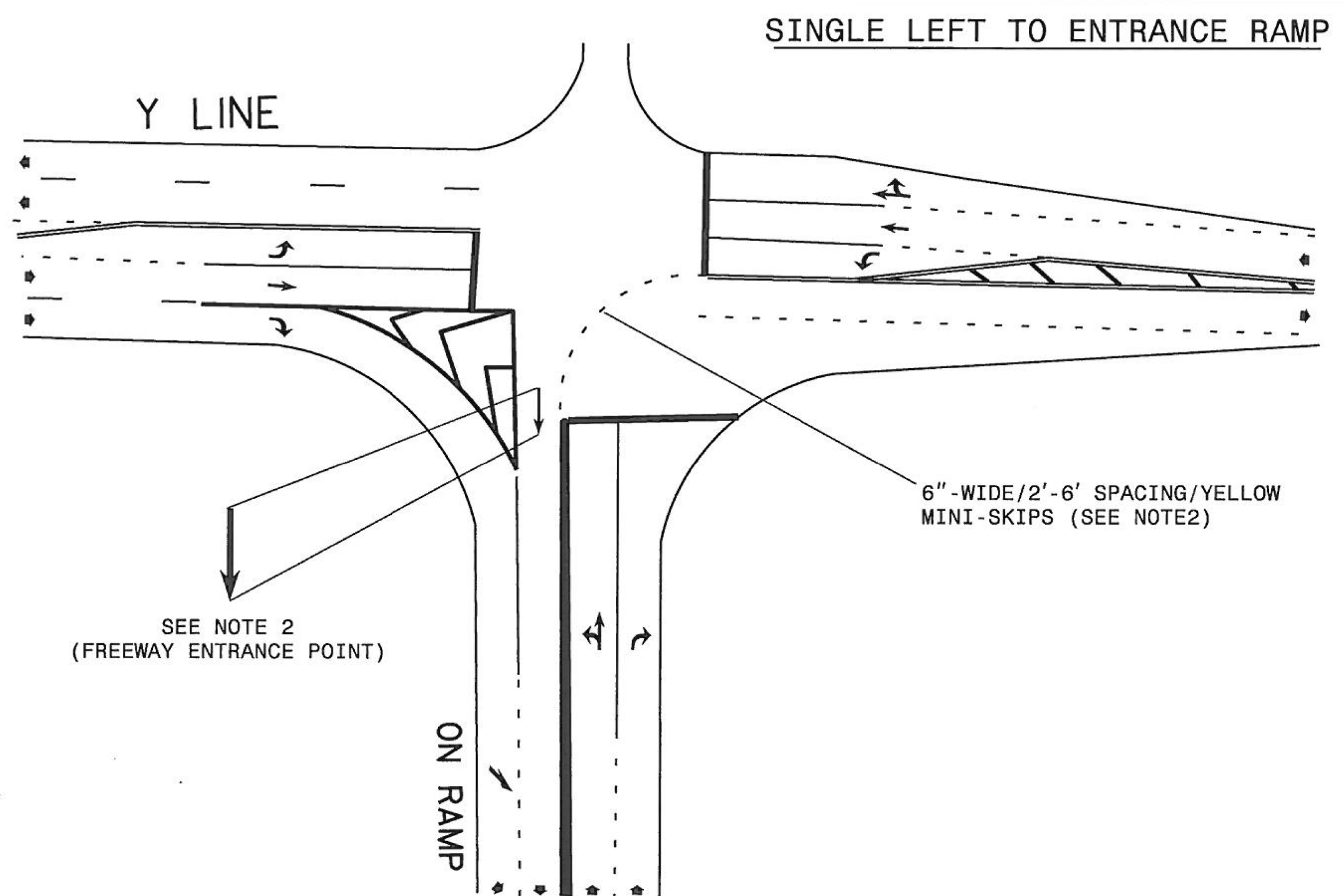
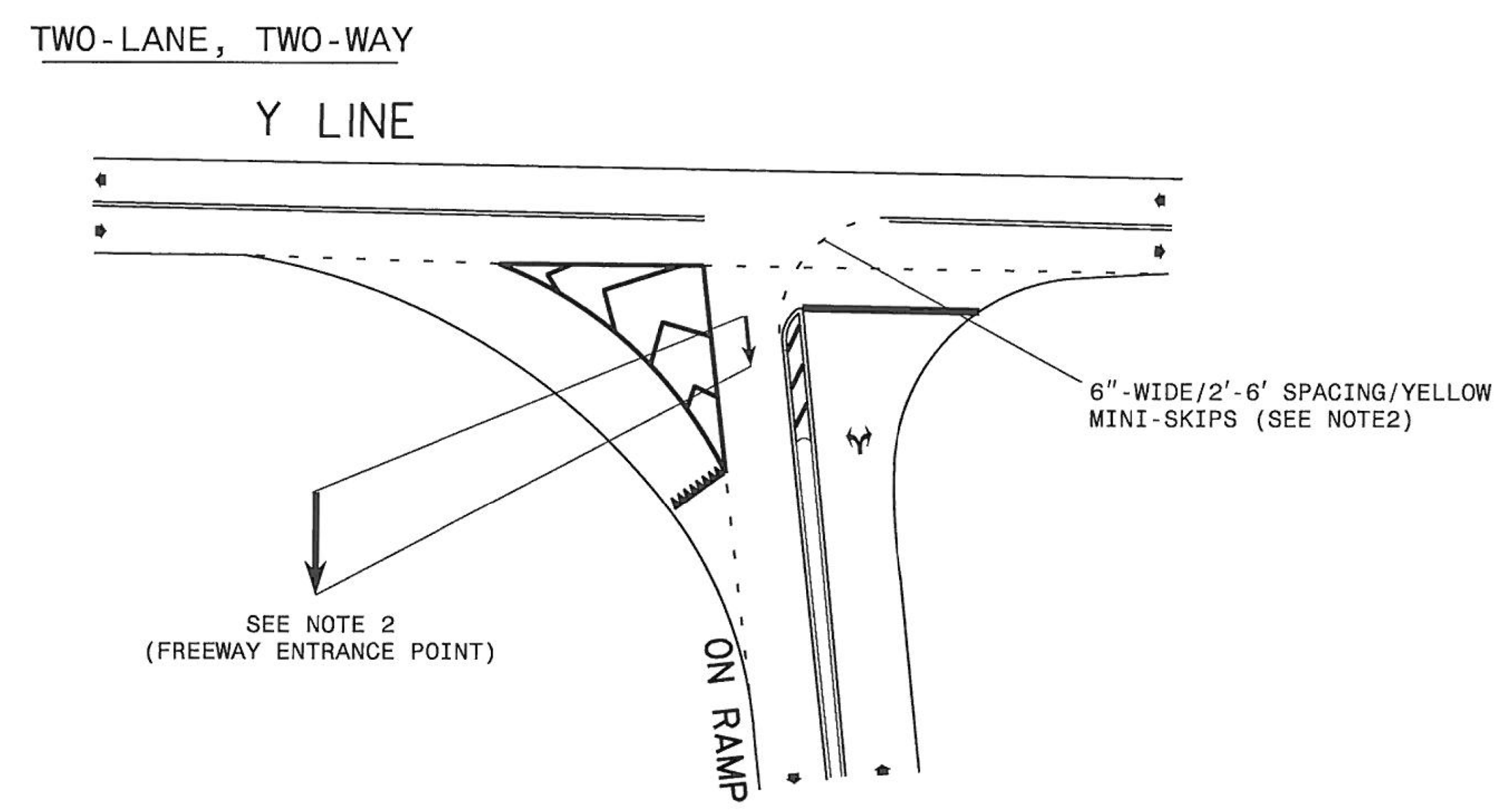

- NOTES:
- REFER TO THE LATEST NCDOT ROADWAY STANDARD DRAWINGS AND THE PAVEMENT MARKING PLANS FOR ADDITIONAL PAVEMENT MARKING GUIDANCE.
 - PROPOSED MINI-SKIPS AND ELONGATED STRAIGHT ARROW SYMBOL MATERIALS SHALL BE PER THE PAVEMENT MARKING PLAN OR AS DIRECTED BY THE ENGINEER. ELONGATED STRAIGHT ARROW SHALL BE APPROXIMATELY 12' LONG AND SHALL BE PAID AS A SYMBOL.

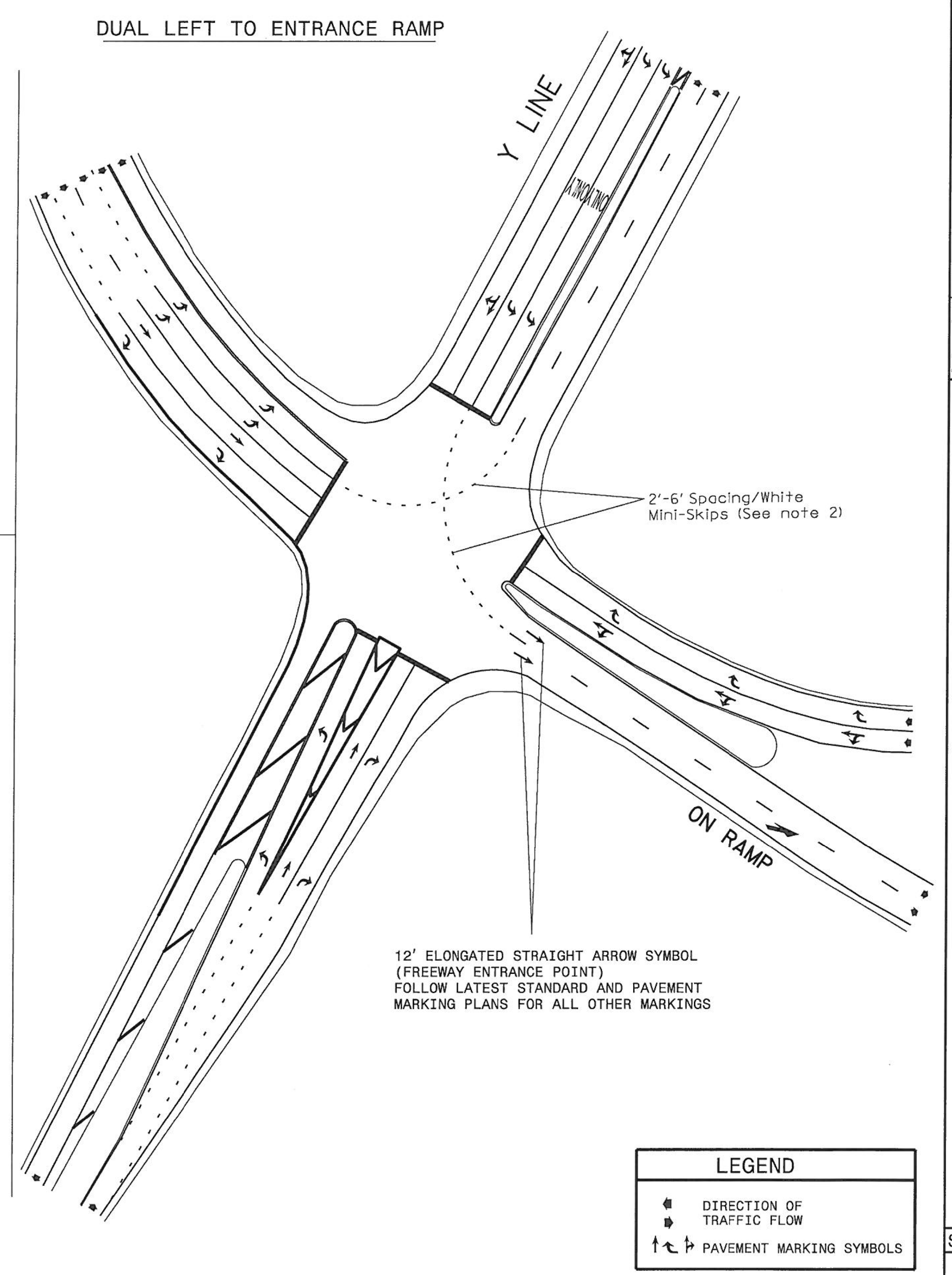

STATE OF NORTH CAROLINA
DEPT. OF TRANSPORTATION
DIVISION OF HIGHWAYS
RALEIGH, N.C.

10-17

ENGLISH STANDARD DETAIL FOR
PAVEMENT MARKINGS
SIDE-BY-SIDE/ADJACENT ON/OFF RAMP
PAVEMENT MARKING LANE TREATMENT

SHEET 1 OF 1

CURB RAMP NUMBER	CURB RAMP LOCATION		CURB RAMP TYPE
	STATION	OFFSET	
1	-L- Sta. 221+15.87 +/-	59.83' LT	TYPE 1
2	-L- Sta. 226+09.02 +/-	54.12' LT	TYPE 3
3	-L- Sta. 226+11.24 +/-	58.13' RT	TYPE 3
4	-Y19- Sta. 12+06.32 +/-	24.29' RT	TYPE 1
5	-Y19- Sta. 12+49.67 +/-	20.64' RT	TYPE 1
6	-Y19- Sta. 15+11.51 +/-	20.50' RT	TYPE 1
7	-Y19- Sta. 15+45.43 +/-	20.50' RT	TYPE 1
8	-Y19- Sta. 22+00.97 +/-	23.33' RT	TYPE 3
9	-Y19- Sta. 22+85.91 +/-	23.62' RT	TYPE 3
10	-Y19- Sta. 27+31.34 +/-	20.50' RT	TYPE 1
11	-Y19- Sta. 27+61.28 +/-	20.39' RT	TYPE 1
12	-Y19- Sta. 28+90.12 +/-	20.50' RT	TYPE 1
13	-Y19- Sta. 29+19.42 +/-	20.50' RT	TYPE 1
14	-Y19- Sta. 30+72.03 +/-	20.50' RT	TYPE 1
15	-Y19- Sta. 31+10.69 +/-	21.00' RT	TYPE 1
16	-Y19- Sta. 34+64.25 +/-	21.00' RT	TYPE 1
17	-Y19- Sta. 35+10.22 +/-	20.50' RT	TYPE 1
18	-Y19- Sta. 35+88.28 +/-	23.46' RT	TYPE 3
19	-Y19- Sta. 36+80.83 +/-	23.42' RT	TYPE 2
20	-Y19- Sta. 38+48.61 +/-	28.81' RT	TYPE 1A
21	-Y19- Sta. 39+61.68 +/-	23.42' RT	TYPE 1A

TIP NO. R - 3300B	SHEET NO. PMP - 3
----------------------	----------------------

APPROVED: _____

DATE: _____

SEAL

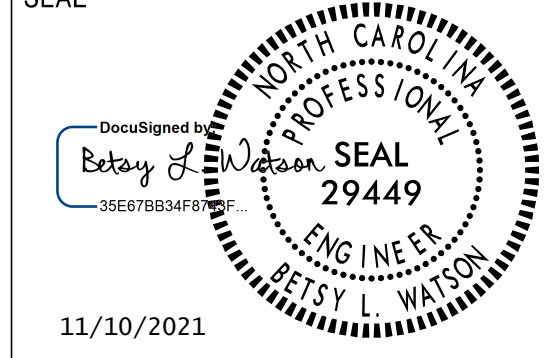



**DOCUMENT NOT CONSIDERED FINAL
UNLESS ALL SIGNATURES COMPLETED**

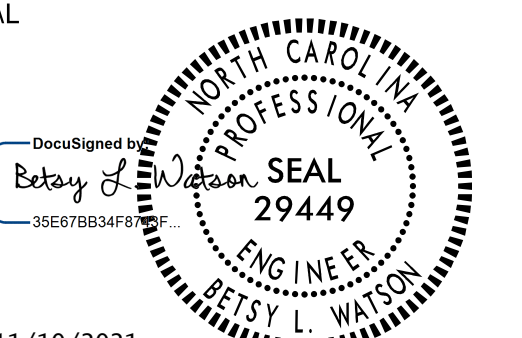

9/13/2021
 U:\Traffic\Signing\CADD\PM\plan_sheets\R-3300B_pmp_03.dgn
 arngood

CURB RAMP LOCATION INDEX

TIP NO. R - 3300B	SHEET NO. PMP - 4
APPROVED: _____	
DATE: _____	
SEAL	
	
11/10/2021	
DOCUMENT NOT CONSIDERED FINAL UNLESS ALL SIGNATURES COMPLETED	
	

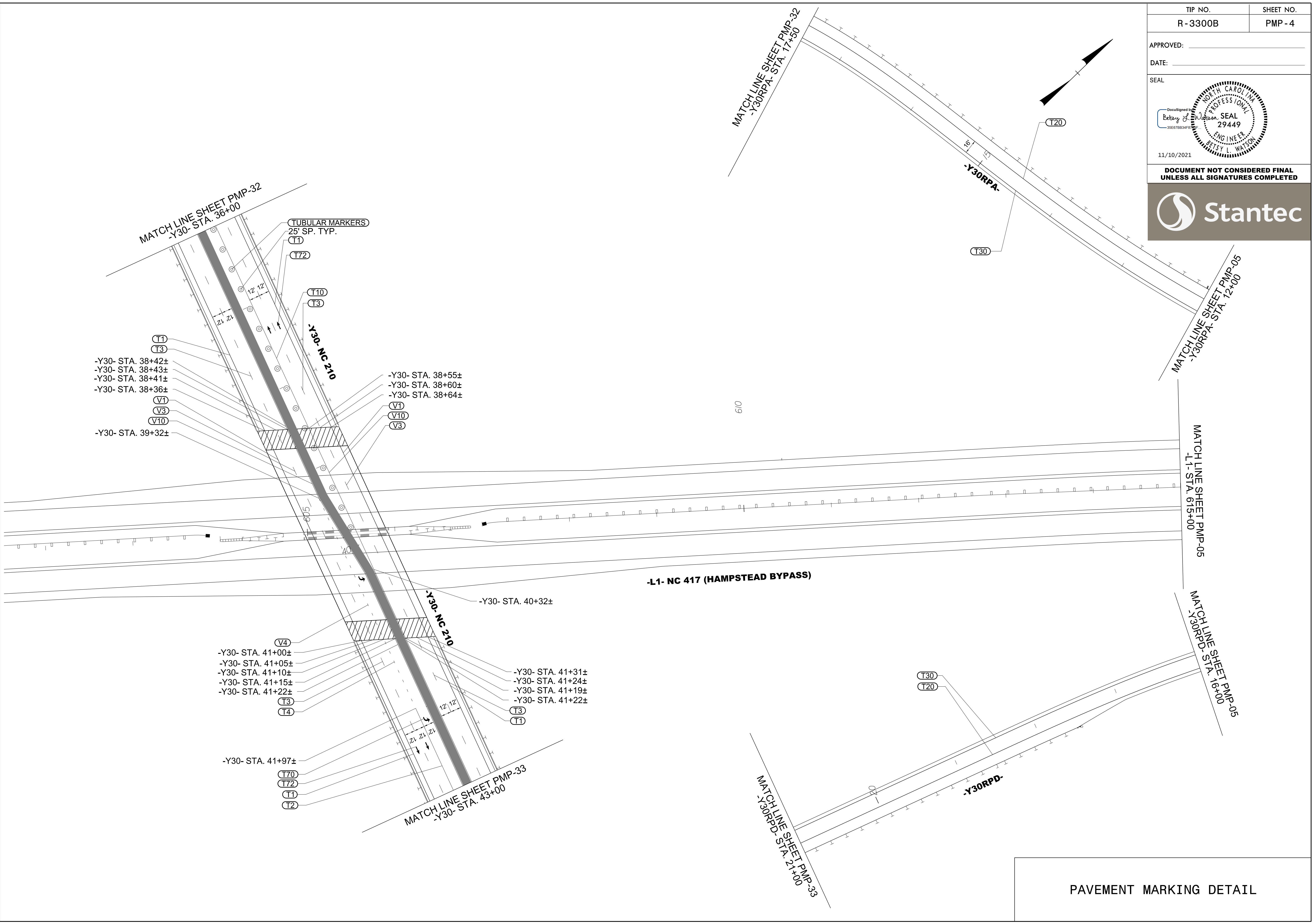

9/13/2021
U:\Traffic\Signing\CADD\pmp\plan_sheets\R-3300B_pmp_04.dgn
angood

PAVEMENT MARKING DETAIL

TIP NO. R-3300B	SHEET NO. PMP-5
APPROVED: _____	
DATE: _____	
SEAL	
<p>11/10/2021</p> <p>DOCUMENT NOT CONSIDERED FINAL UNLESS ALL SIGNATURES COMPLETED</p>	

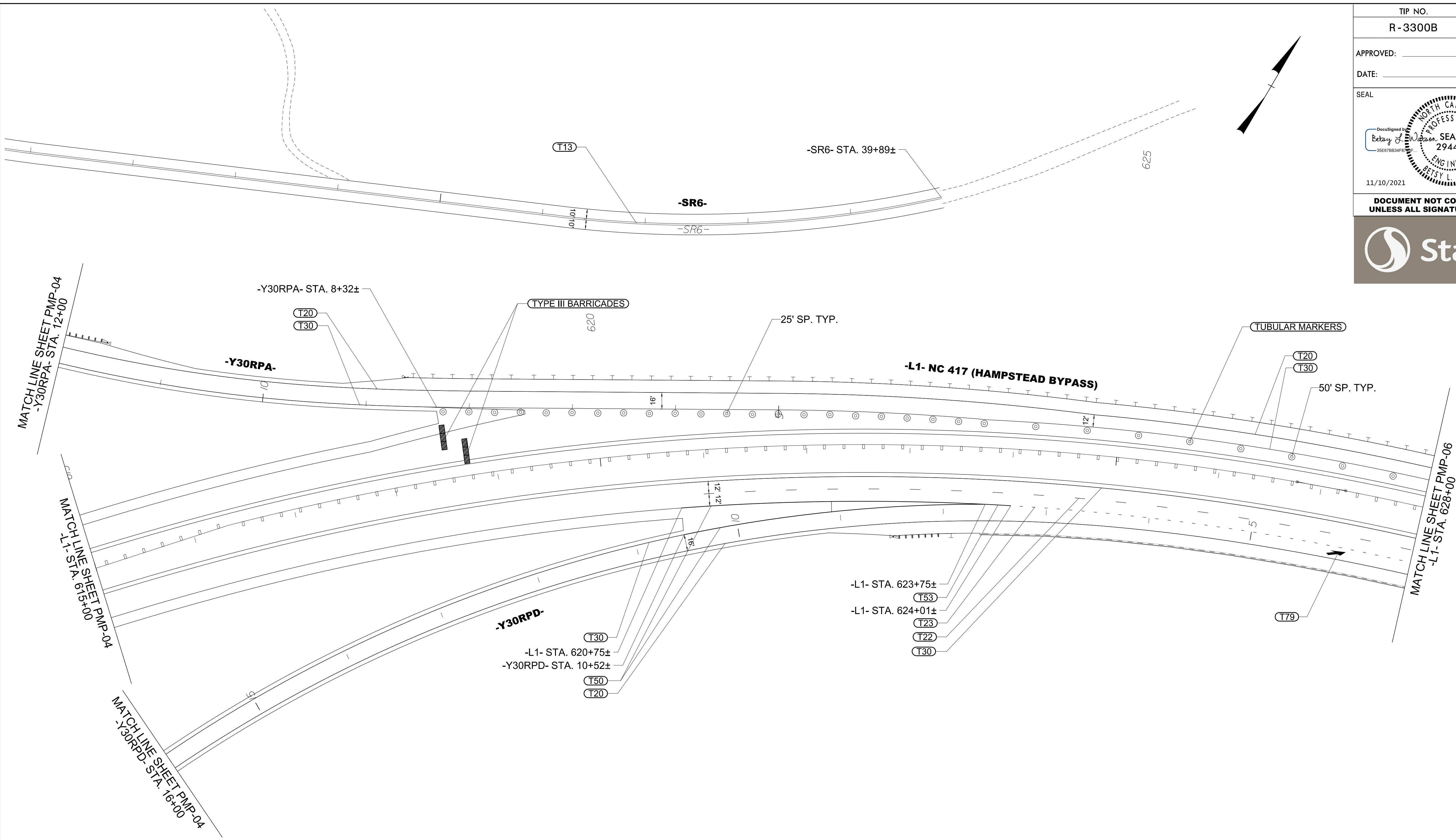

9/13/2021
 U:\Traffic\Signing\CADD\pmp\plan_sheets\R-3300B_pmp_05.dgn
 angood

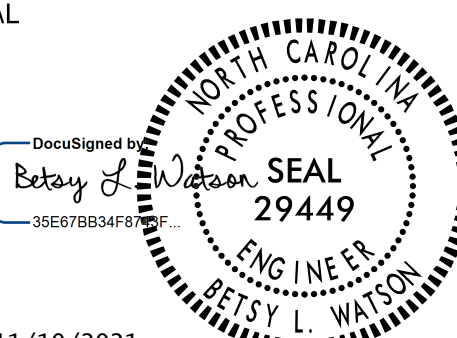

PAVEMENT MARKING DETAIL

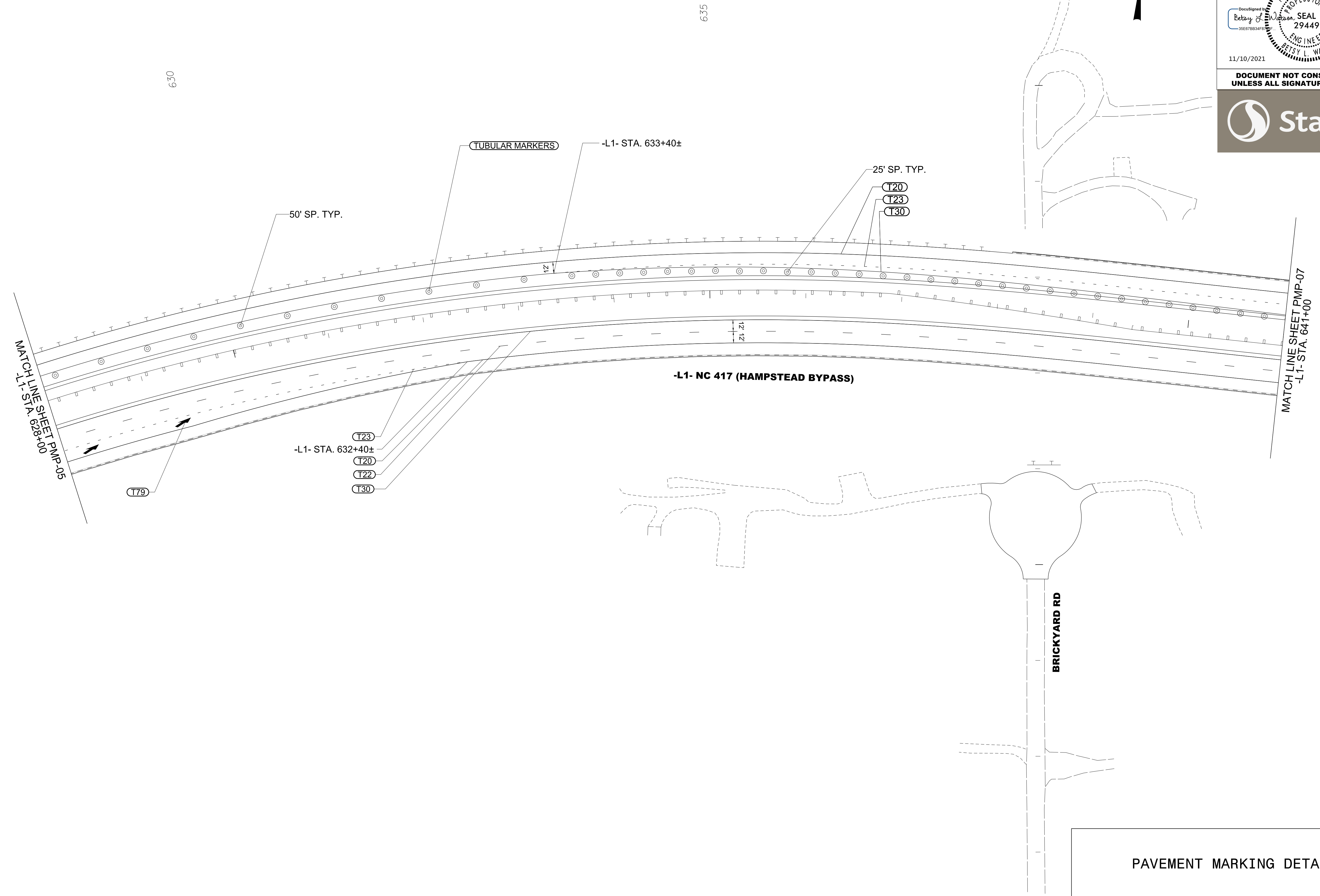
TIP NO. R-3300B	SHEET NO. PMP-6
APPROVED: _____	
DATE: _____	
SEAL	
	
11/10/2021	
DOCUMENT NOT CONSIDERED FINAL UNLESS ALL SIGNATURES COMPLETED	



9/13/2021
 U:\Traffic\Signing\CADD\PM\plan_sheets\R-3300B_pmp_06.dgn
 arngood

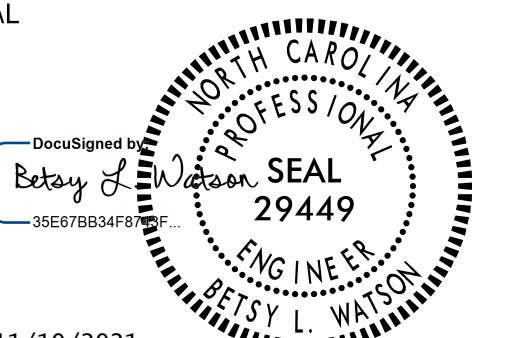

PAVEMENT MARKING DETAIL

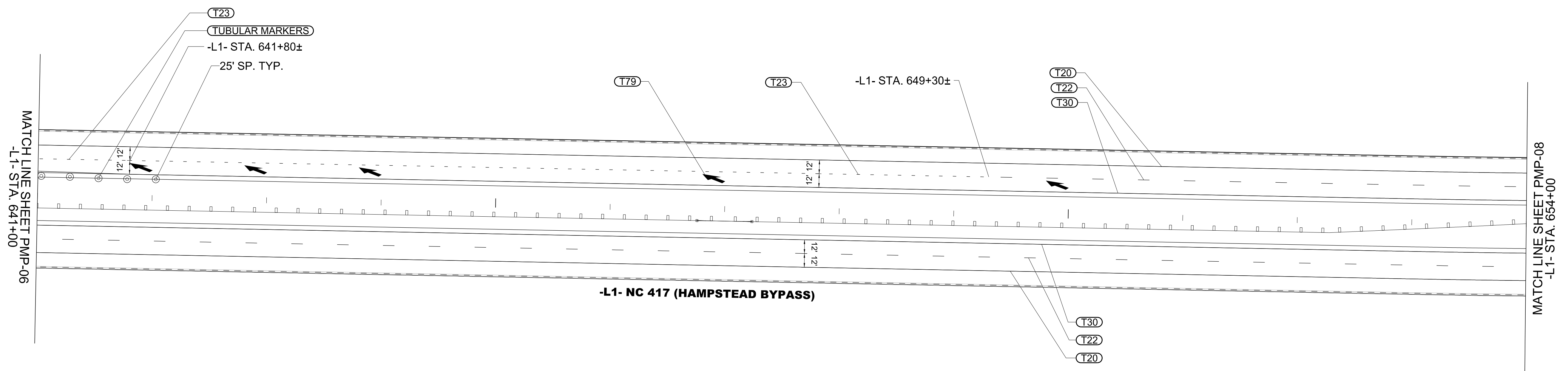
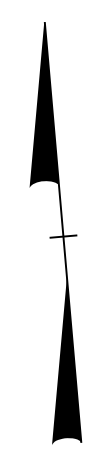
TIP NO. R-3300B	SHEET NO. PMP-7
APPROVED: _____	
DATE: _____	
SEAL	
	
11/10/2021	
DOCUMENT NOT CONSIDERED FINAL UNLESS ALL SIGNATURES COMPLETED	
	



9/13/2021
U:\Traffic\Signing\CADD\pmp\plan_sheets\R-3300B_pmp_07.dgn
angood

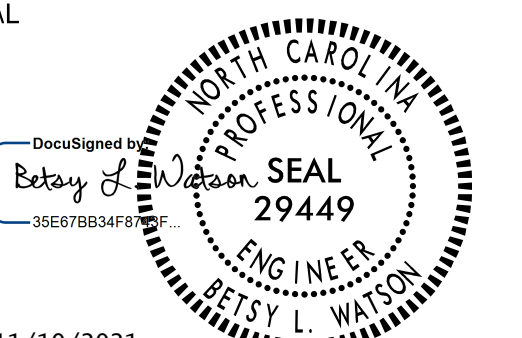

PAVEMENT MARKING DETAIL

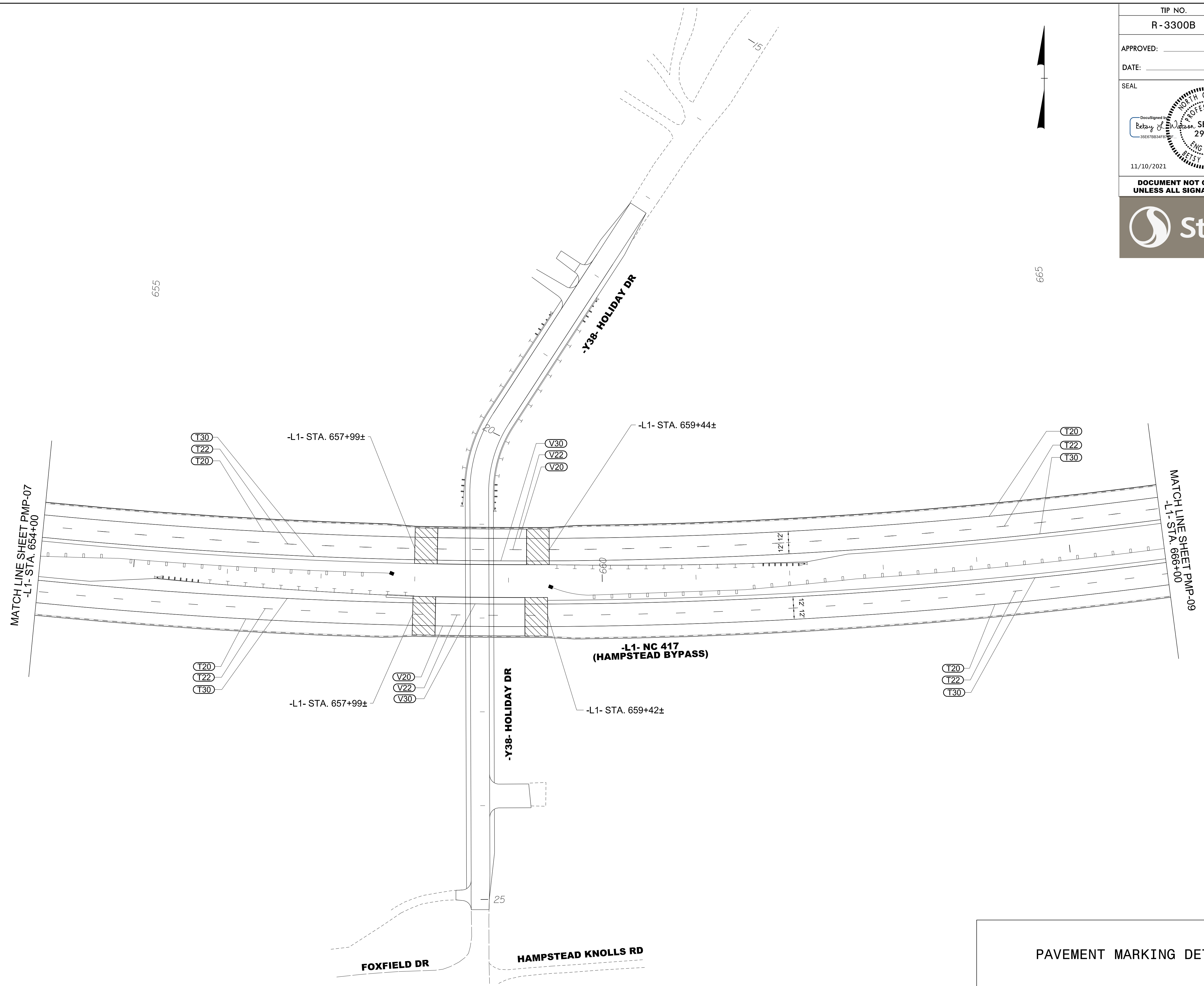
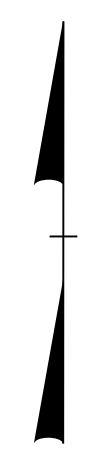
TIP NO. R-3300B	SHEET NO. PMP-8
APPROVED: _____	
DATE: _____	
SEAL	
	
11/10/2021	
DOCUMENT NOT CONSIDERED FINAL UNLESS ALL SIGNATURES COMPLETED	
	



9/13/2021
U:\Traffic\Signing\CADD\pmp\plan_sheets\R-3300B_pmp_08.dgn
angood

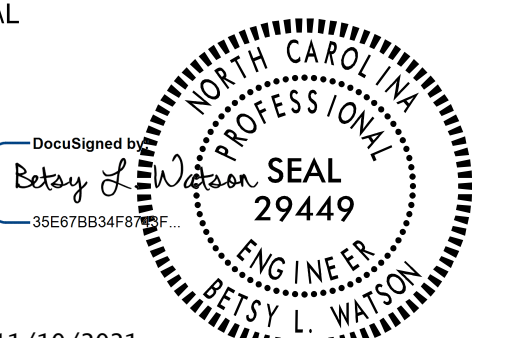

PAVEMENT MARKING DETAIL

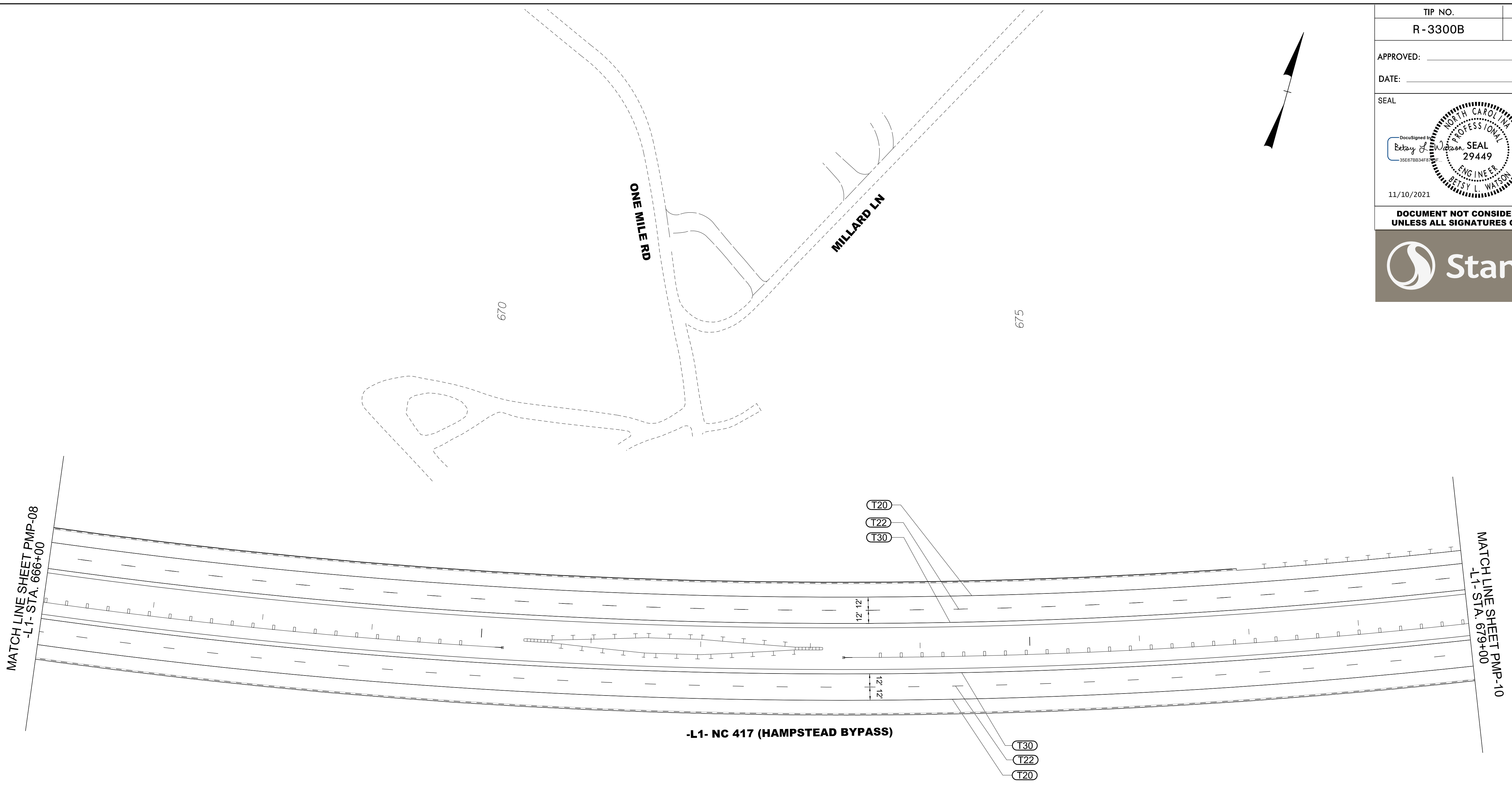
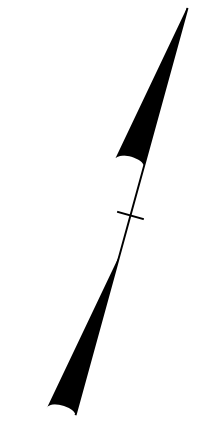
TIP NO. R-3300B	SHEET NO. PMP-9
APPROVED: _____	
DATE: _____	
SEAL	
	
11/10/2021	
DOCUMENT NOT CONSIDERED FINAL UNLESS ALL SIGNATURES COMPLETED	
	

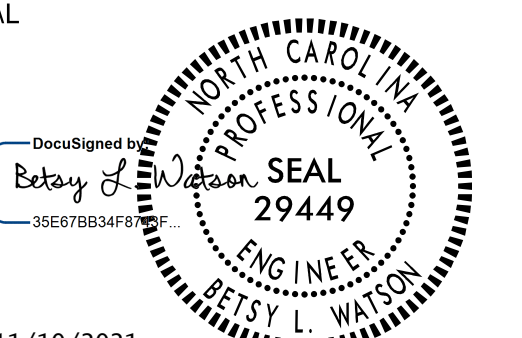

9/13/2021
Us:\Traffic\Signing\CADD\pmp\plan_sheets\R-3300B_pmp_09.dgn
angood

PAVEMENT MARKING DETAIL

TIP NO. R-3300B	SHEET NO. PMP-10
APPROVED: _____	
DATE: _____	
SEAL	
	
11/10/2021	
DOCUMENT NOT CONSIDERED FINAL UNLESS ALL SIGNATURES COMPLETED	
	

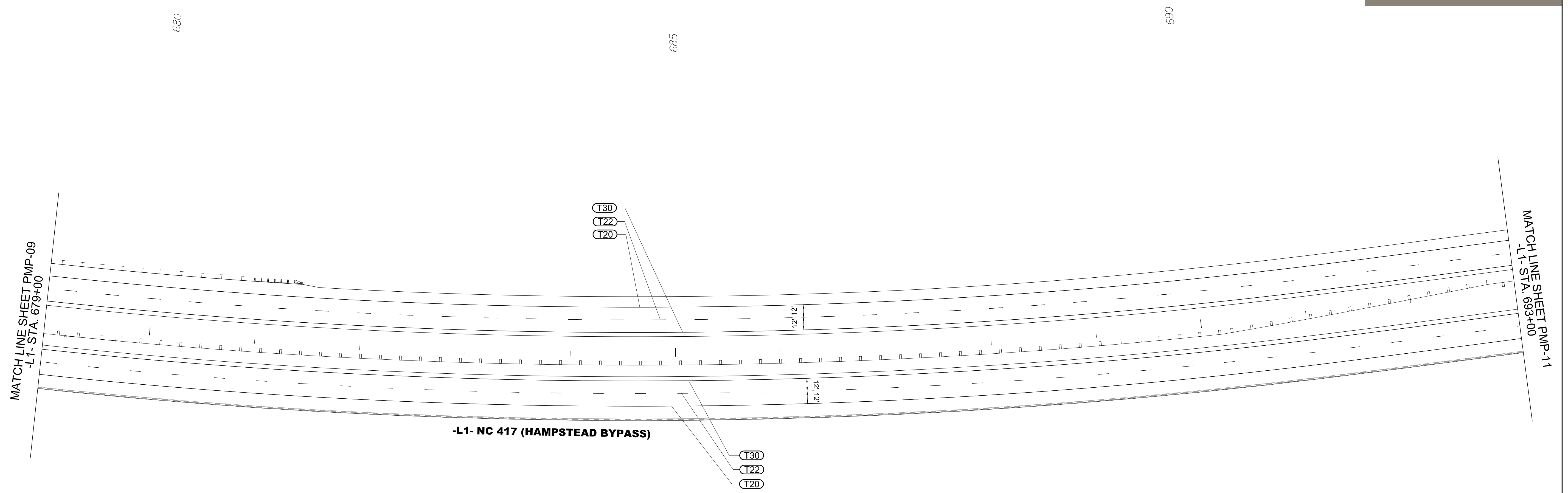
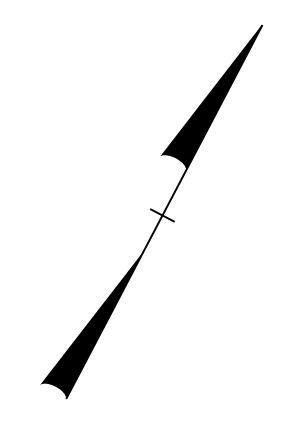

9/13/2021
Us:\Traffic\Signing\CADD\pmp\plan_sheets\R-3300B_pmp_10.dgn
angood

PAVEMENT MARKING DETAIL

TIP NO. R-3300B	SHEET NO. PMP-11
APPROVED: _____	
DATE: _____	
SEAL	
<p>11/10/2021</p> <p>DOCUMENT NOT CONSIDERED FINAL UNLESS ALL SIGNATURES COMPLETED</p>	

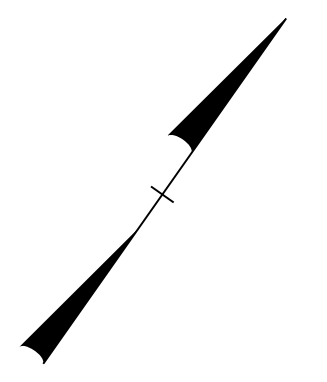

695

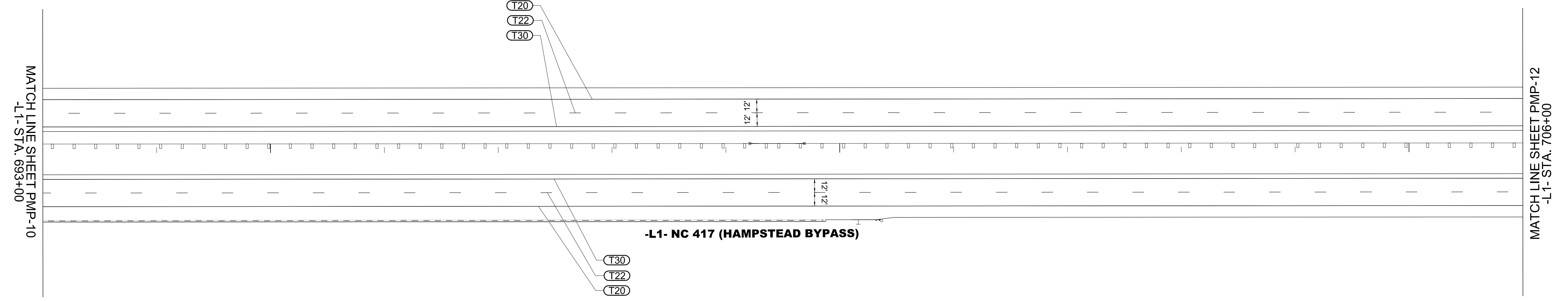

700

705

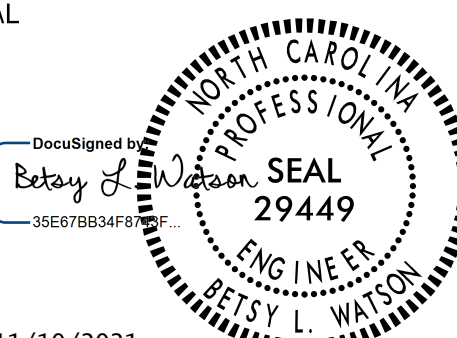

9/13/2021
U:\Traffic\Signing\CADD\pmp\plan_sheets\R-3300B_pmp_11.dgn
angood

PAVEMENT MARKING DETAIL

TIP NO. R-3300B	SHEET NO. PMP-12
APPROVED: _____	
DATE: _____	
SEAL	
	
11/10/2021	
DOCUMENT NOT CONSIDERED FINAL UNLESS ALL SIGNATURES COMPLETED	
	

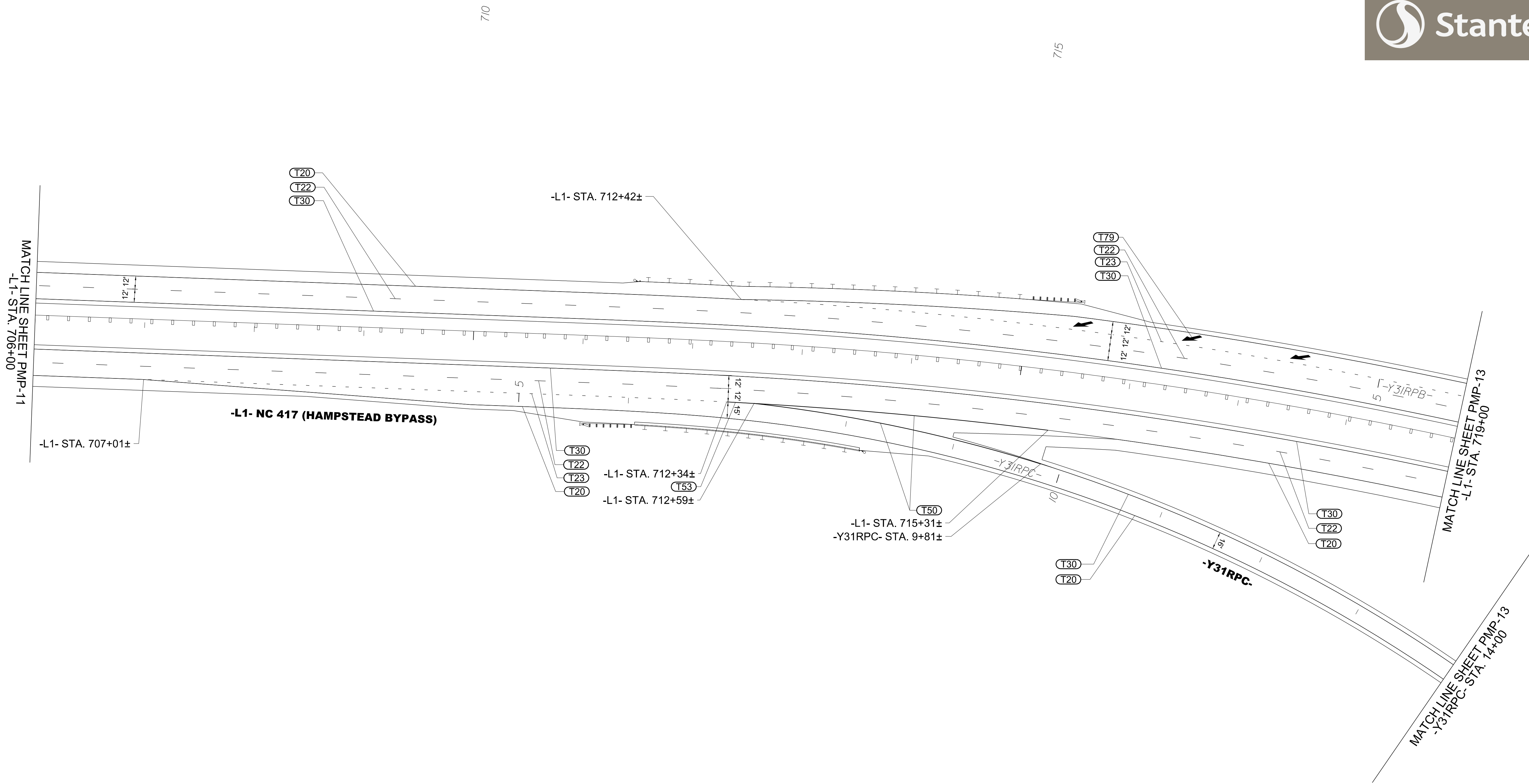

9/13/2021
 Us\Traffic\Signing\CADD\pmp\plan_sheets\R-3300B_pmp_12.dgn
 arngood

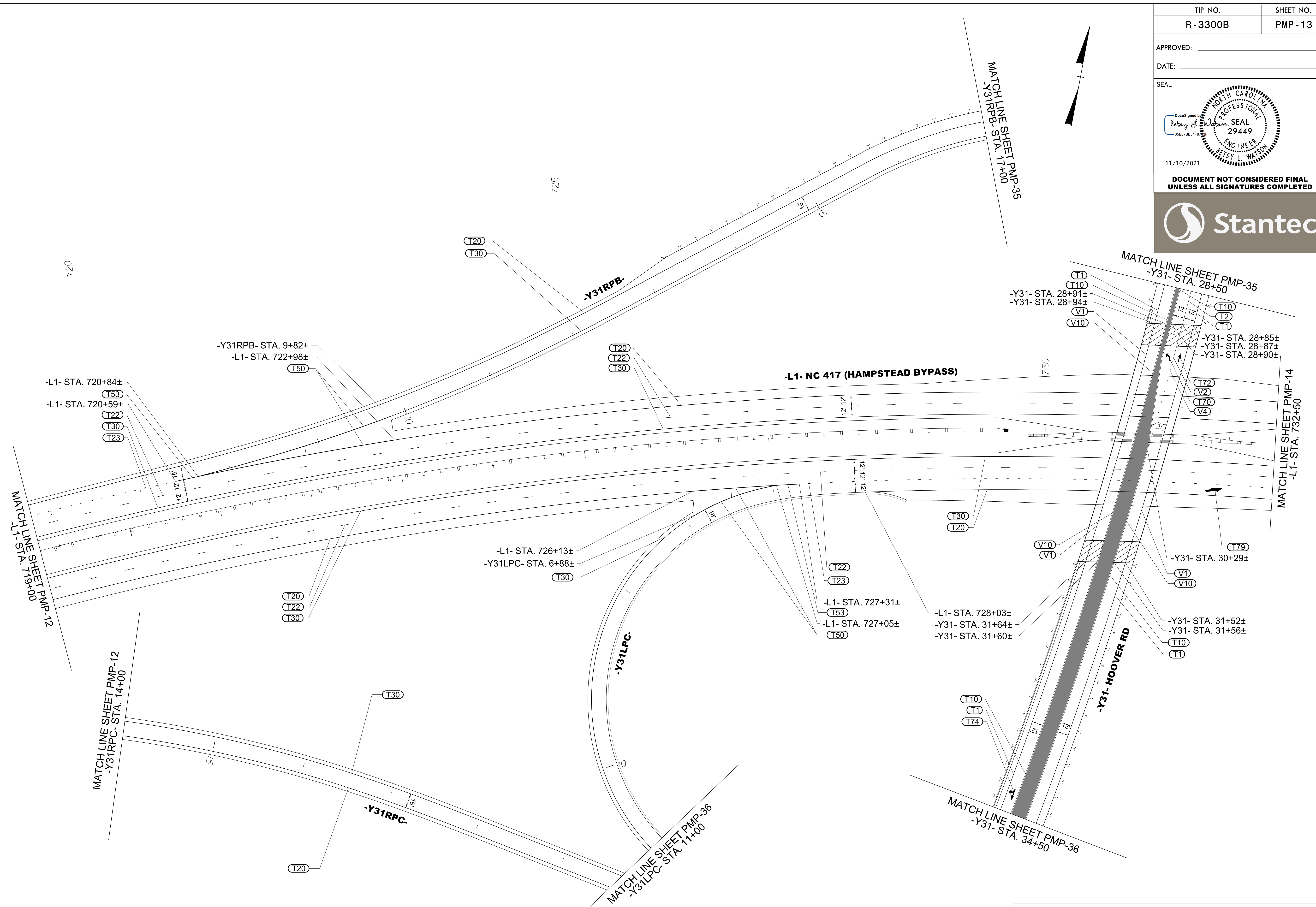

PAVEMENT MARKING DETAIL

TIP NO. R-3300B	SHEET NO. PMP-13
APPROVED: _____	
DATE: _____	
SEAL	
11/10/2021	
DOCUMENT NOT CONSIDERED FINAL UNLESS ALL SIGNATURES COMPLETED	



PAVEMENT MARKING DETAIL

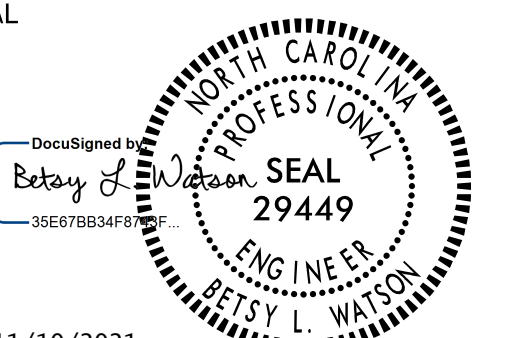

9/13/2021
 U:\Traffic\Signing\CADD\pmp\plan_sheets\R-3300B_pmp_13.dgn
 arngood

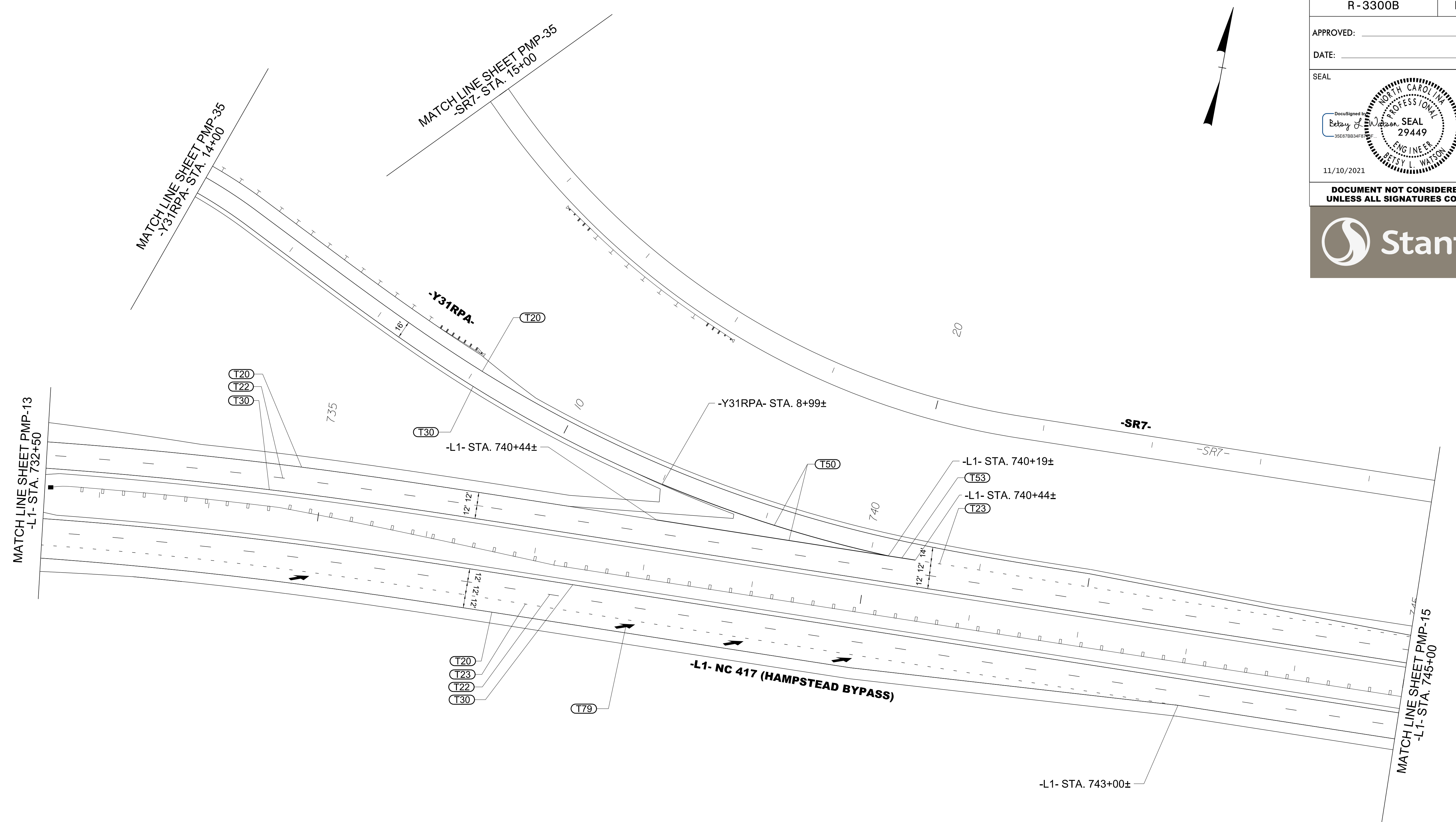
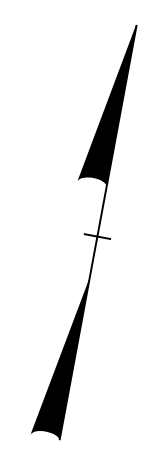
TIP NO. R-3300B	SHEET NO. PMP-14
APPROVED: _____	
DATE: _____	
SEAL	
	
11/10/2021	
DOCUMENT NOT CONSIDERED FINAL UNLESS ALL SIGNATURES COMPLETED	
	

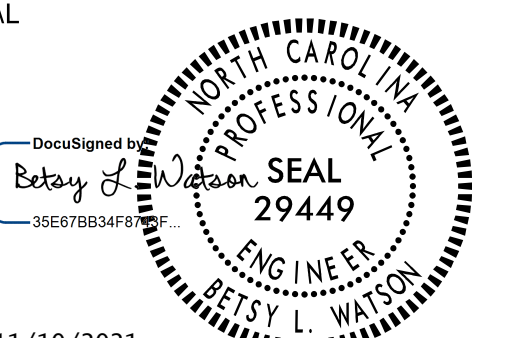

9/13/2021
U:\Traffic\Signing\CADD\pmp\plan_sheets\R-3300B_pmp_14.dgn
angood

PAVEMENT MARKING DETAIL

TIP NO. R-3300B	SHEET NO. PMP-15
APPROVED: _____	
DATE: _____	
SEAL	
	
11/10/2021	
DOCUMENT NOT CONSIDERED FINAL UNLESS ALL SIGNATURES COMPLETED	
	

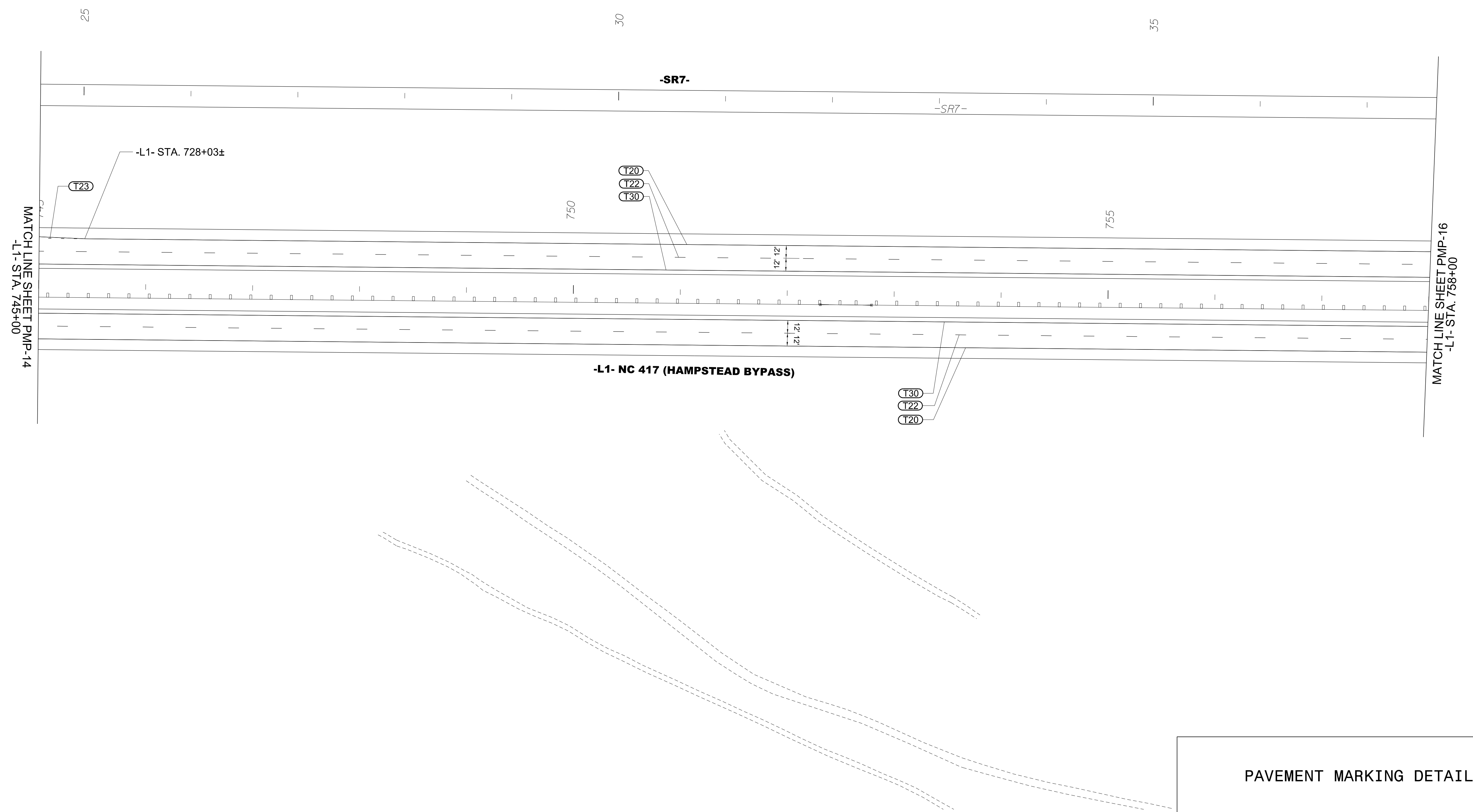
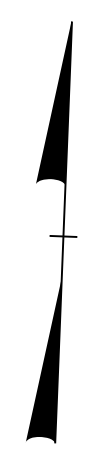

9/13/2021
U:\Traffic\Signing\CADD\pmp\plan_sheets\R-3300B_pmp_15.dgn
angood

PAVEMENT MARKING DETAIL

TIP NO. R-3300B	SHEET NO. PMP-16
APPROVED: _____	
DATE: _____	
SEAL	
11/10/2021	
DOCUMENT NOT CONSIDERED FINAL UNLESS ALL SIGNATURES COMPLETED	

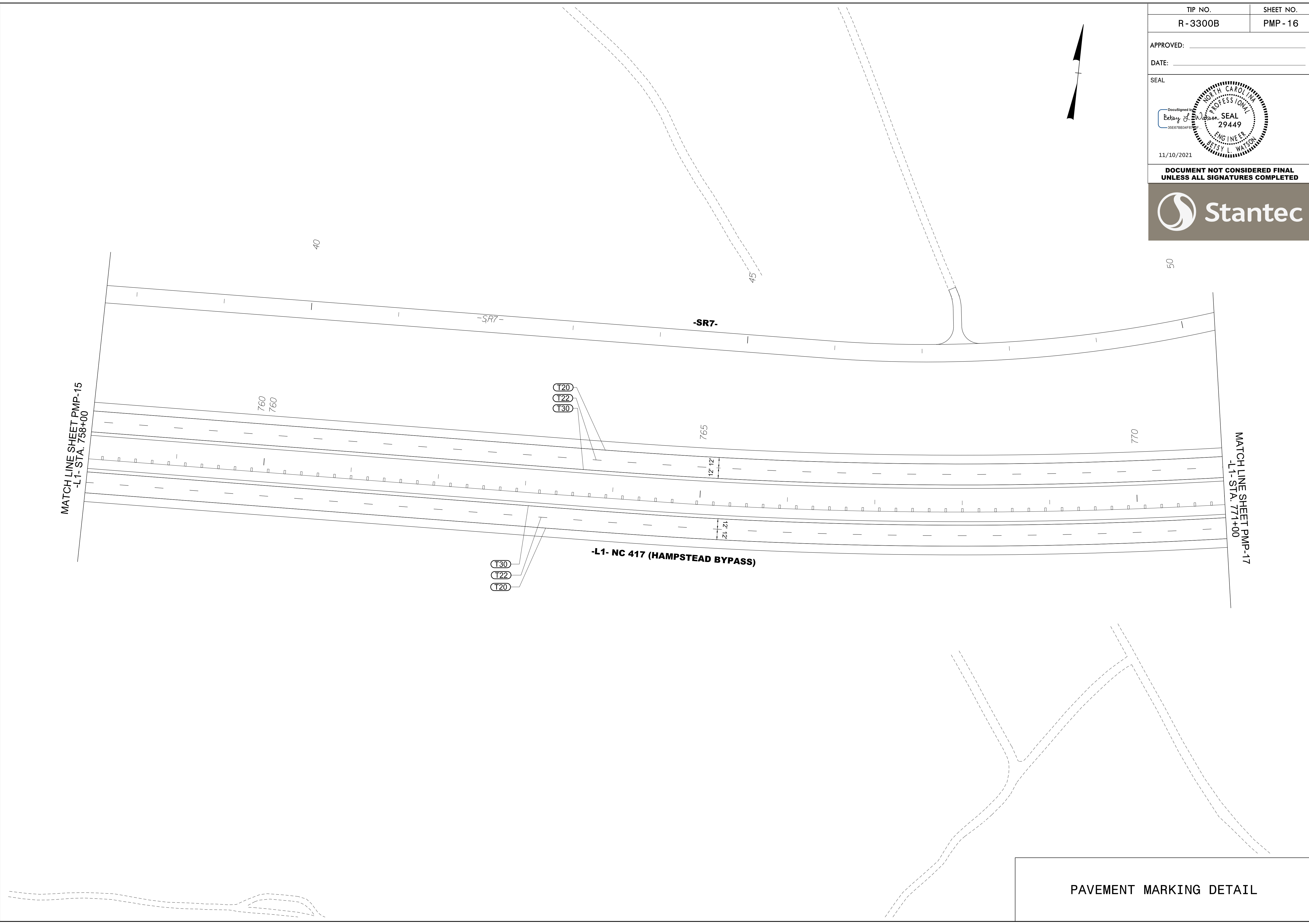
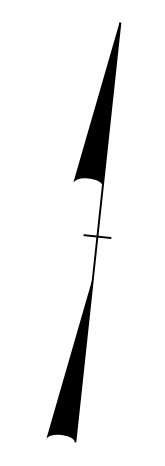

9/13/2021
U:\Traffic\Signing\CADD\pmp\plan_sheets\R-3300B_pmp_16.dgn
angood

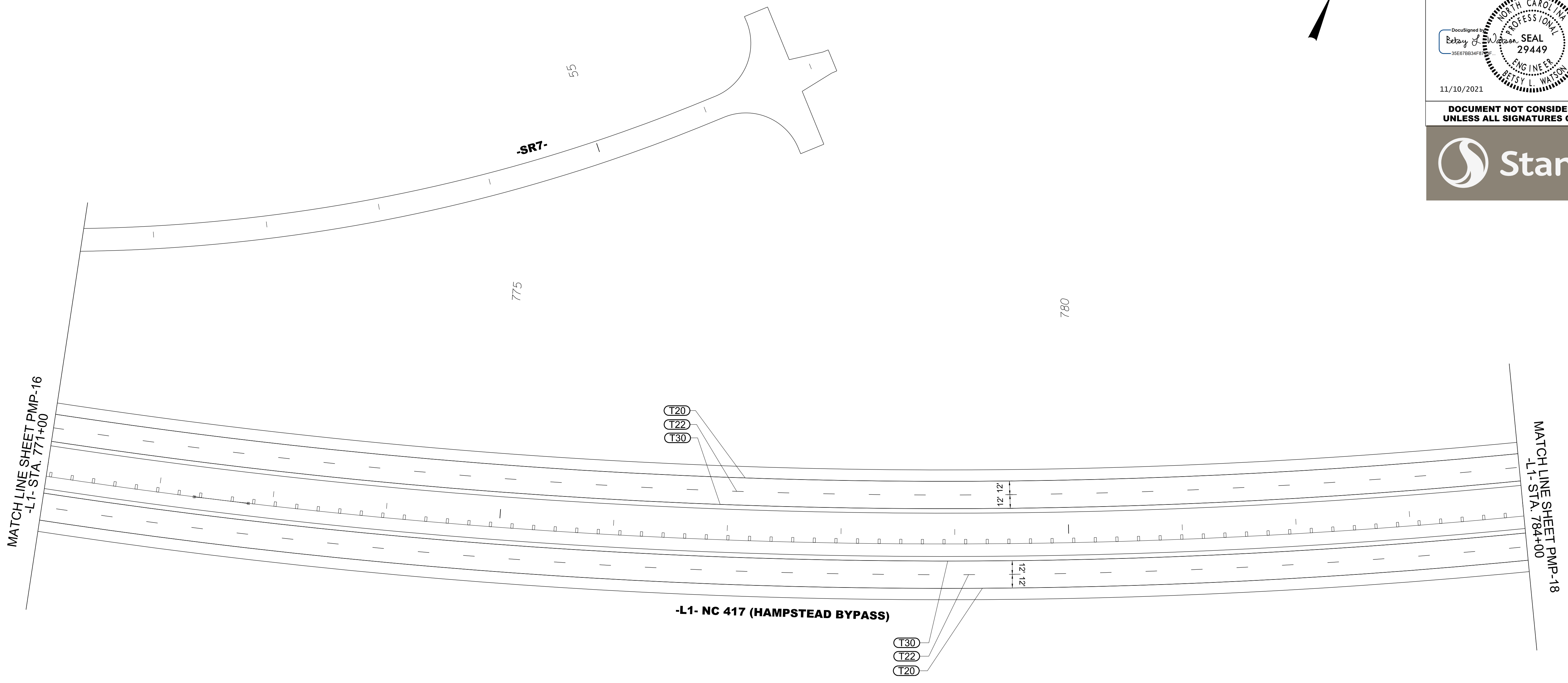
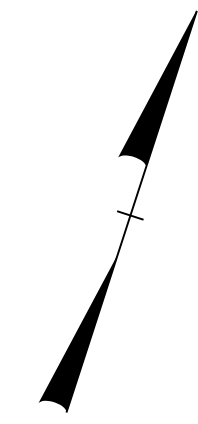

PAVEMENT MARKING DETAIL

TIP NO. R-3300B	SHEET NO. PMP-17
APPROVED: _____	
DATE: _____	
SEAL	
<p>11/10/2021</p> <p>DOCUMENT NOT CONSIDERED FINAL UNLESS ALL SIGNATURES COMPLETED</p>	

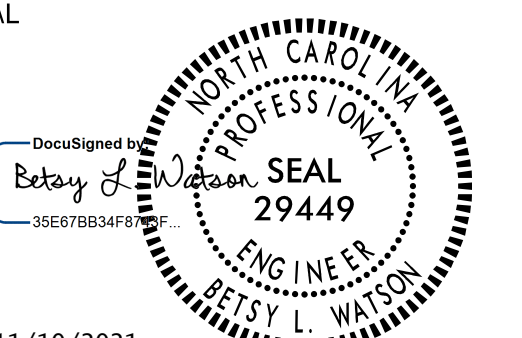

9/13/2021
U:\Traffic\Signing\CADD\PM\plan_sheets\R-3300B_pmp_17.dgn
angood

PAVEMENT MARKING DETAIL

TIP NO. R-3300B	SHEET NO. PMP-18
APPROVED: _____	
DATE: _____	
SEAL	
	
11/10/2021	
DOCUMENT NOT CONSIDERED FINAL UNLESS ALL SIGNATURES COMPLETED	
	

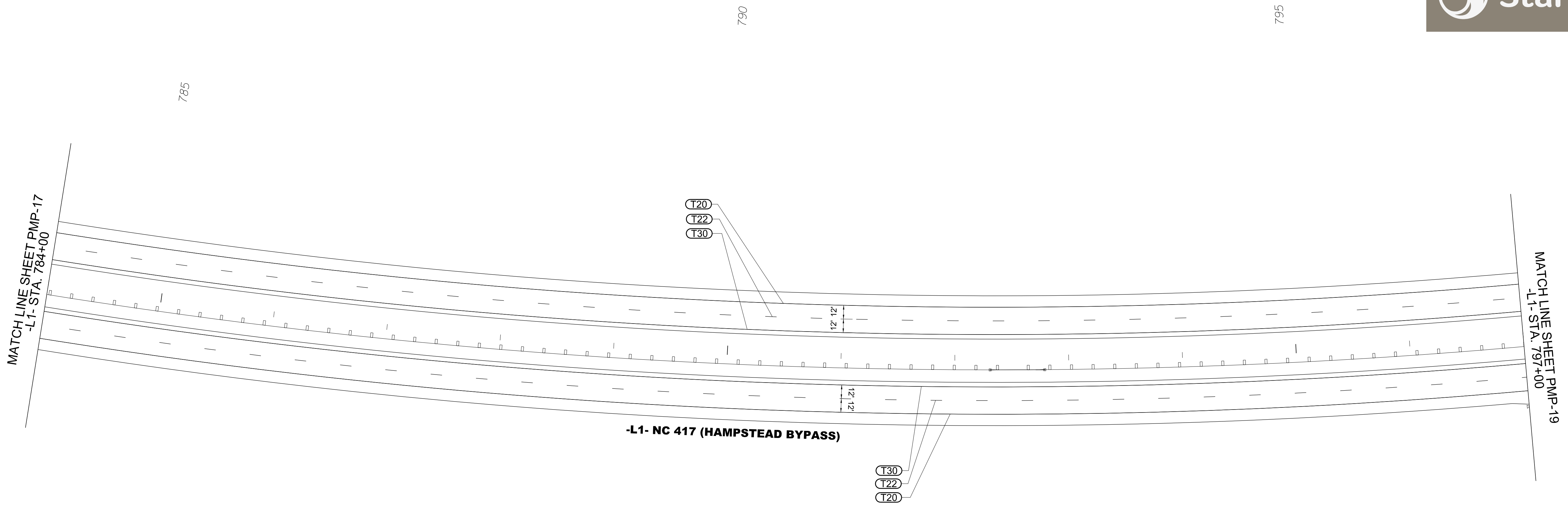
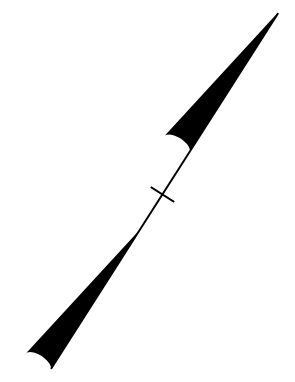

9/13/2021
Us:\Traffic\Signing\CADD\pmp\plan_sheets\R-3300B_pmp_18.dgn
angood

PAVEMENT MARKING DETAIL

TIP NO. R-3300B	SHEET NO. PMP-19
APPROVED: _____	
DATE: _____	
SEAL	
<p>11/10/2021</p> <p>DOCUMENT NOT CONSIDERED FINAL UNLESS ALL SIGNATURES COMPLETED</p>	

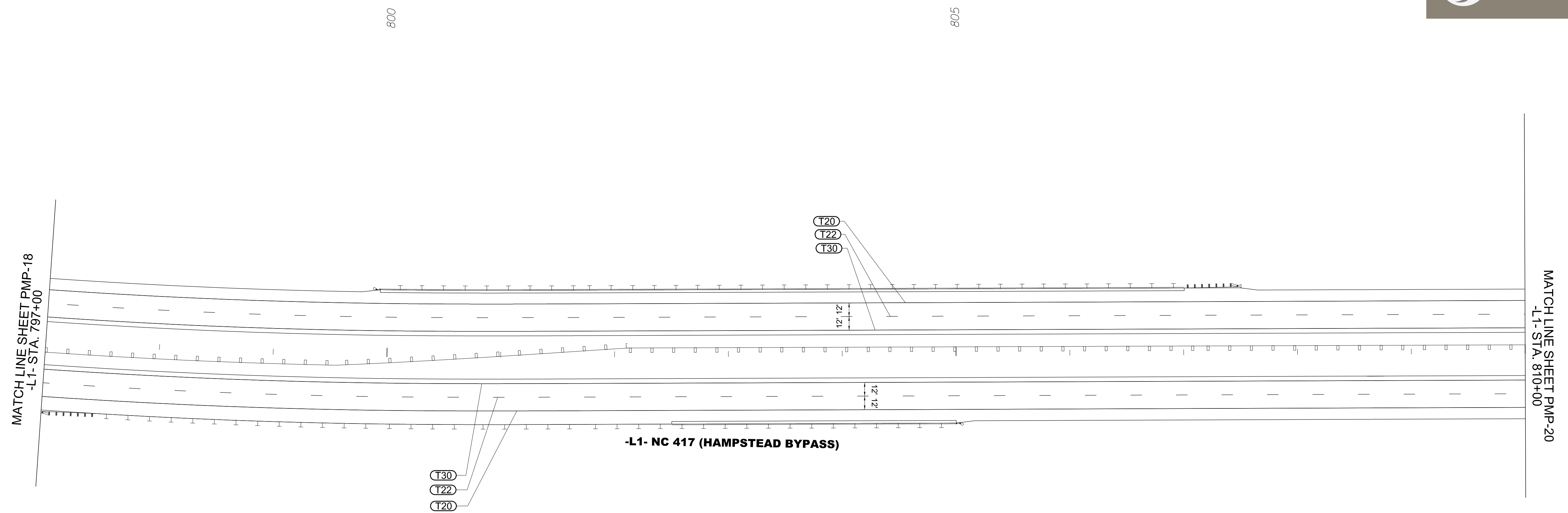
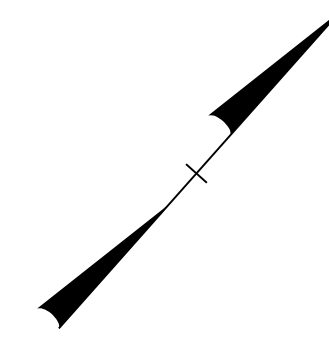

9/13/2021
 Us:\Traffic\Signing\CADD\pmp\plan_sheets\R-3300B_pmp_19.dgn
 arngood

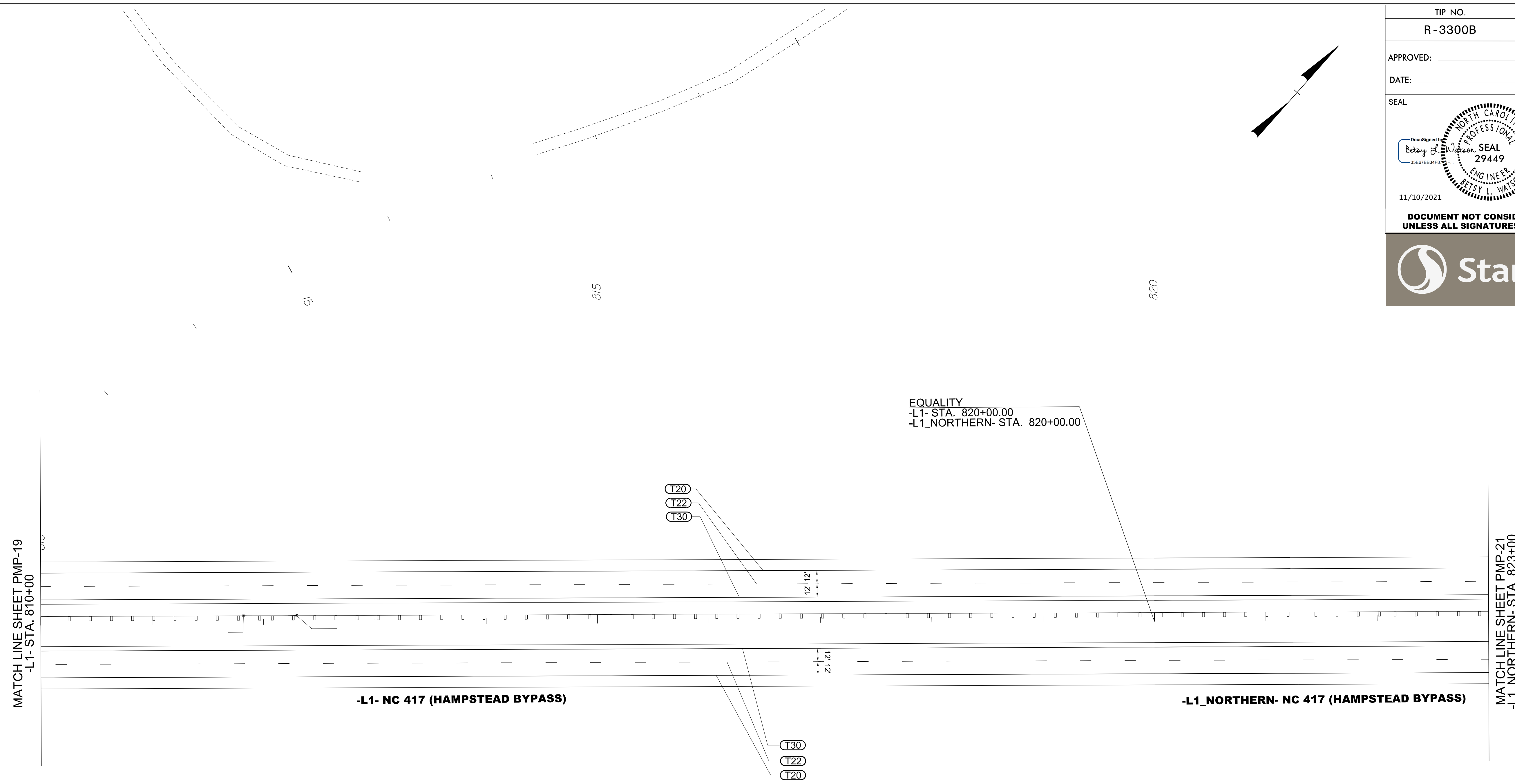

PAVEMENT MARKING DETAIL

TIP NO. R-3300B	SHEET NO. PMP-20
APPROVED: _____	
DATE: _____	
SEAL	
<p>11/10/2021</p> <p>DOCUMENT NOT CONSIDERED FINAL UNLESS ALL SIGNATURES COMPLETED</p>	

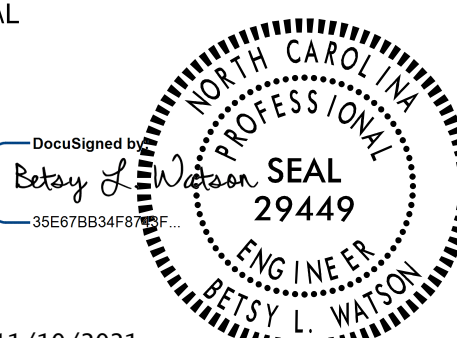

9/13/2021
Us:\Traffic\Signing\CADD\pmp\plan_sheets\R-3300B_pmp_20.dgn
angood

PAVEMENT MARKING DETAIL

TIP NO. R-3300B	SHEET NO. PMP-21
APPROVED: _____	
DATE: _____	
SEAL	
	
11/10/2021	
DOCUMENT NOT CONSIDERED FINAL UNLESS ALL SIGNATURES COMPLETED	
	

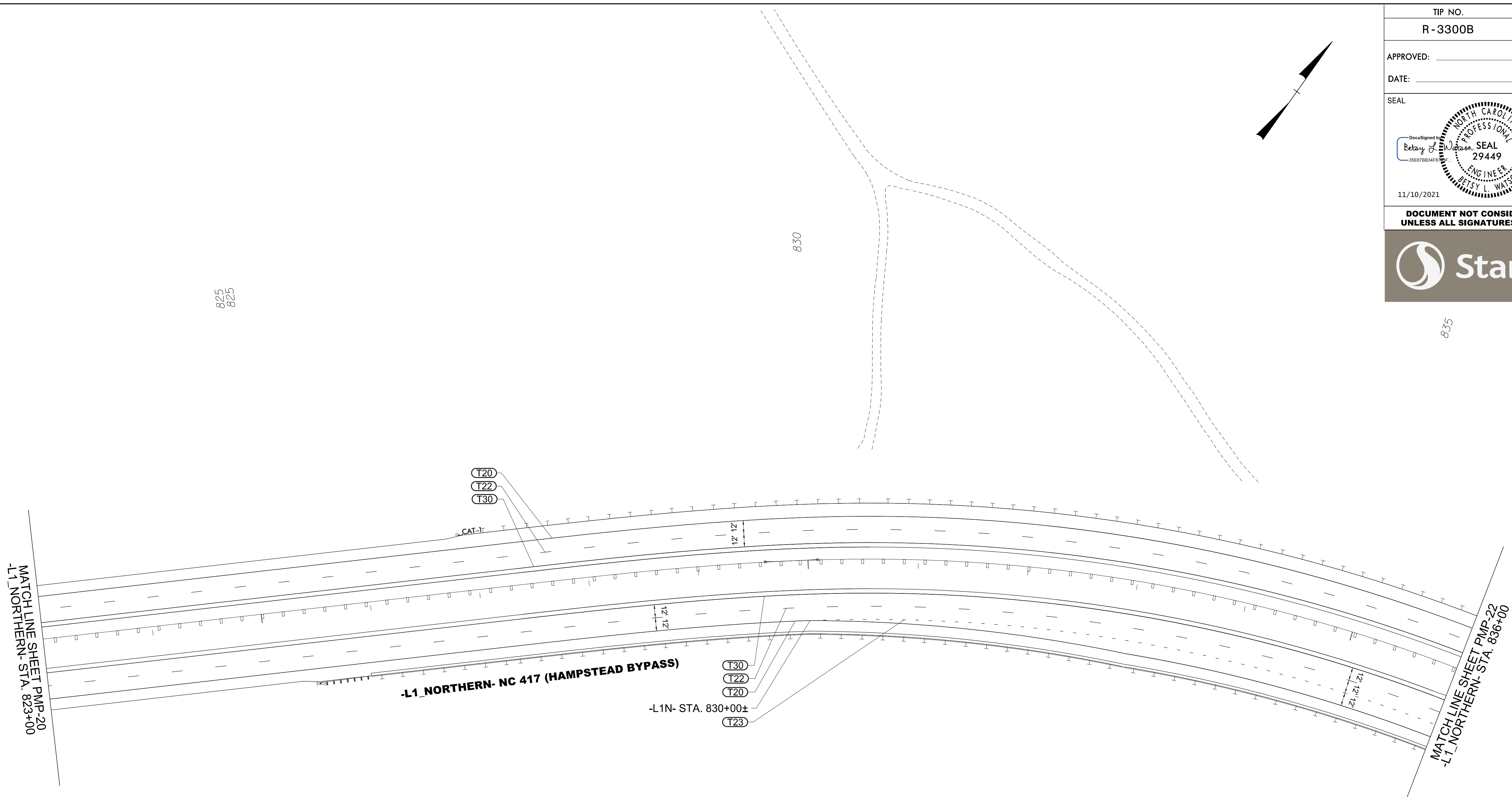

9/13/2021
U:\Traffic\Signing\CADD\pmp\plan_sheets\R-3300B_pmp_21.dgn
angood

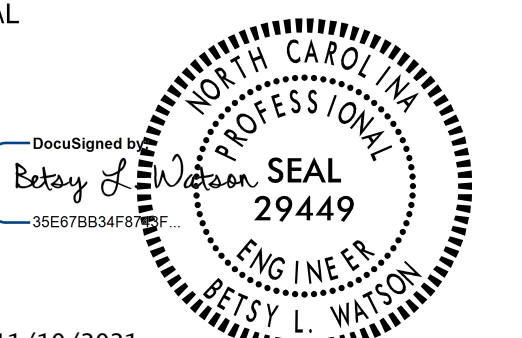

PAVEMENT MARKING DETAIL

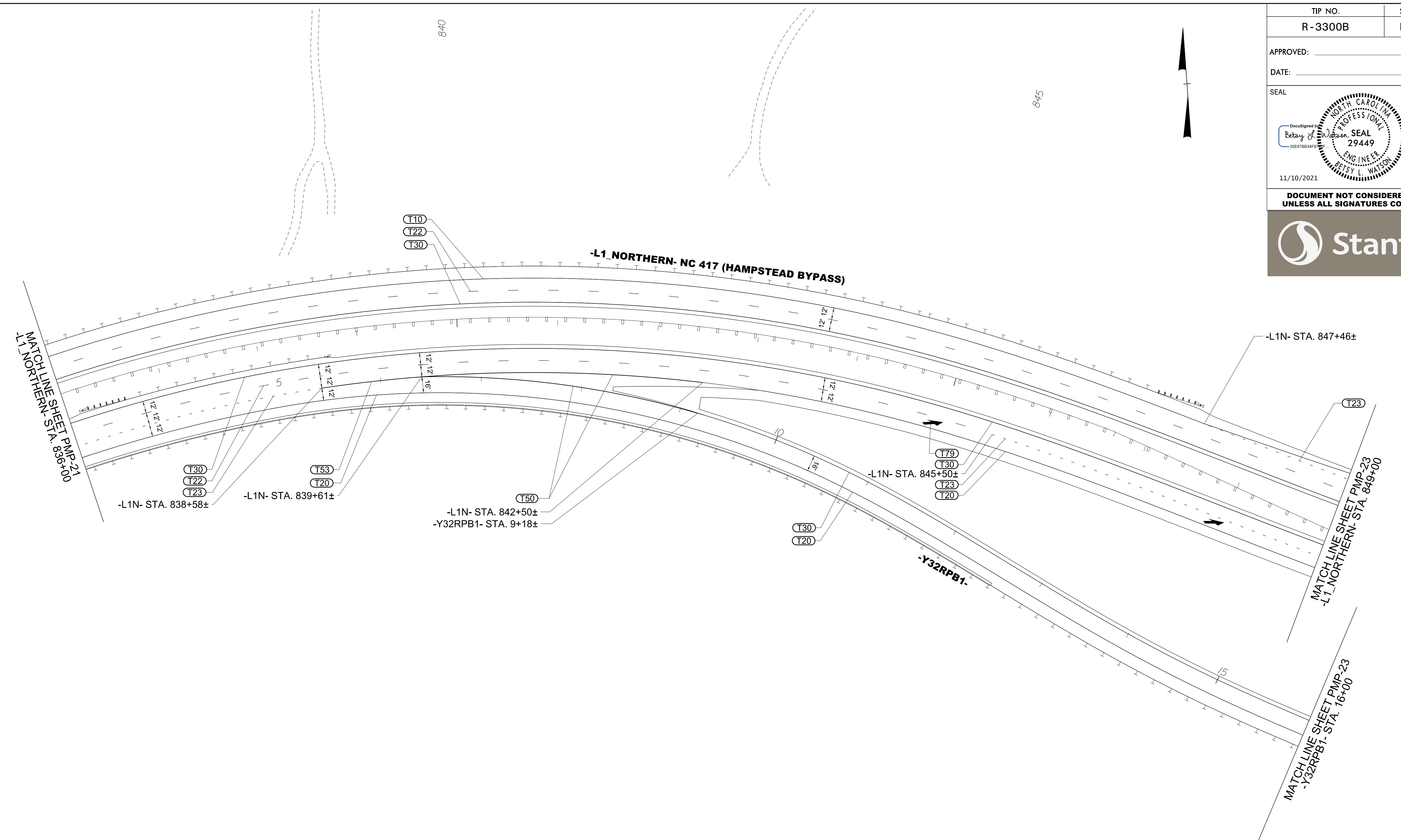
TIP NO. R-3300B	SHEET NO. PMP-22
APPROVED: _____	
DATE: _____	
SEAL	
	
11/10/2021	
DOCUMENT NOT CONSIDERED FINAL UNLESS ALL SIGNATURES COMPLETED	

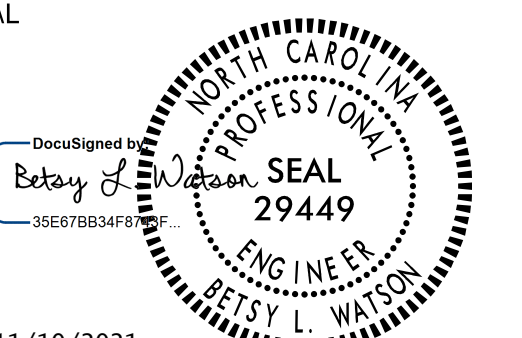

9/13/2021
 U:\Traffic\Signing\CADD\PM\plan_sheets\R-3300B_pmp_22.dgn
 angood

PAVEMENT MARKING DETAIL

TIP NO. R-3300B	SHEET NO. PMP-23
APPROVED: _____	
DATE: _____	
SEAL	
	
11/10/2021	
DOCUMENT NOT CONSIDERED FINAL UNLESS ALL SIGNATURES COMPLETED	
	

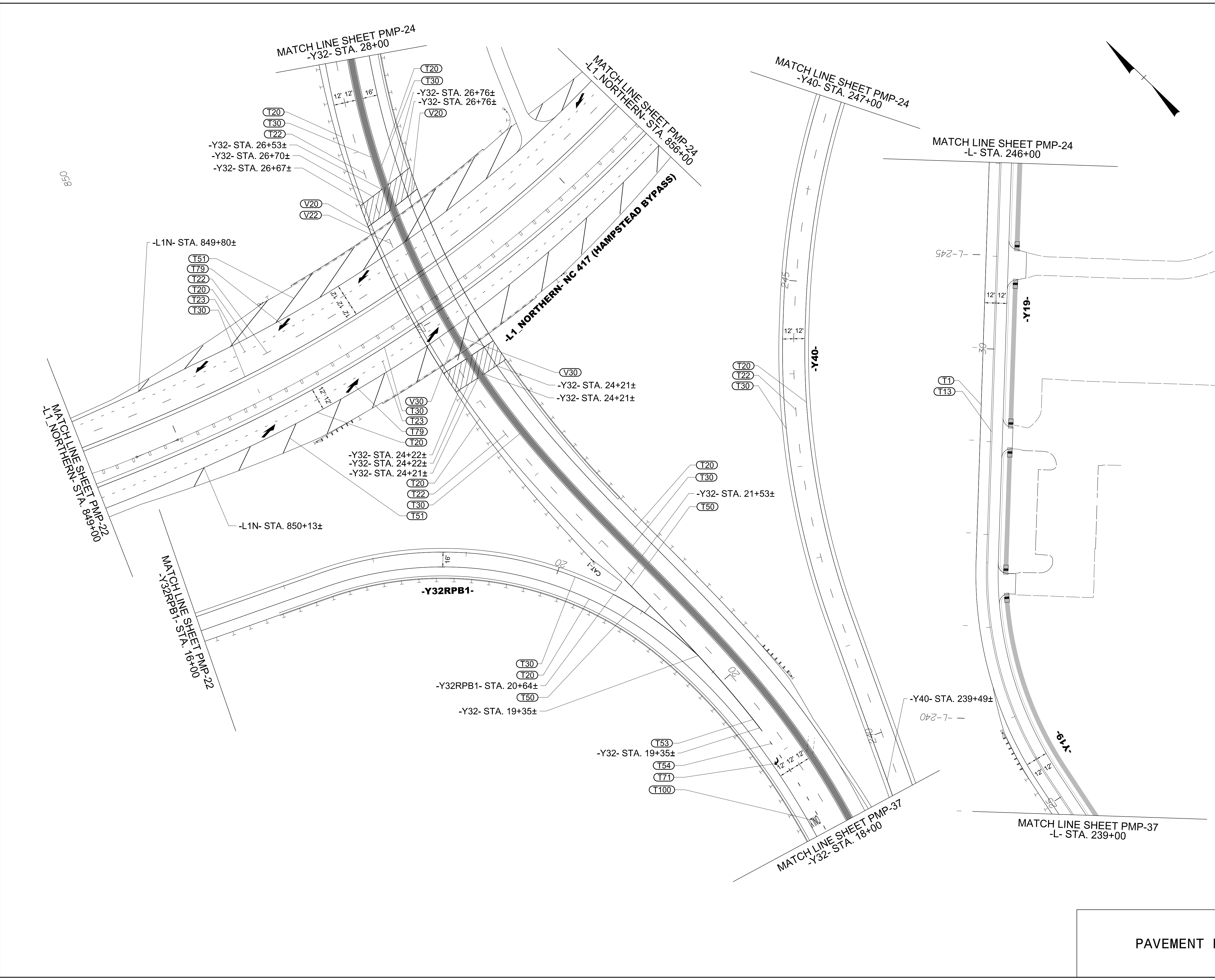

9/13/2021
 U:\Traffic\Signing\CADD\PM\plan_sheets\R-3300B_pmp_23.dgn
 arngood

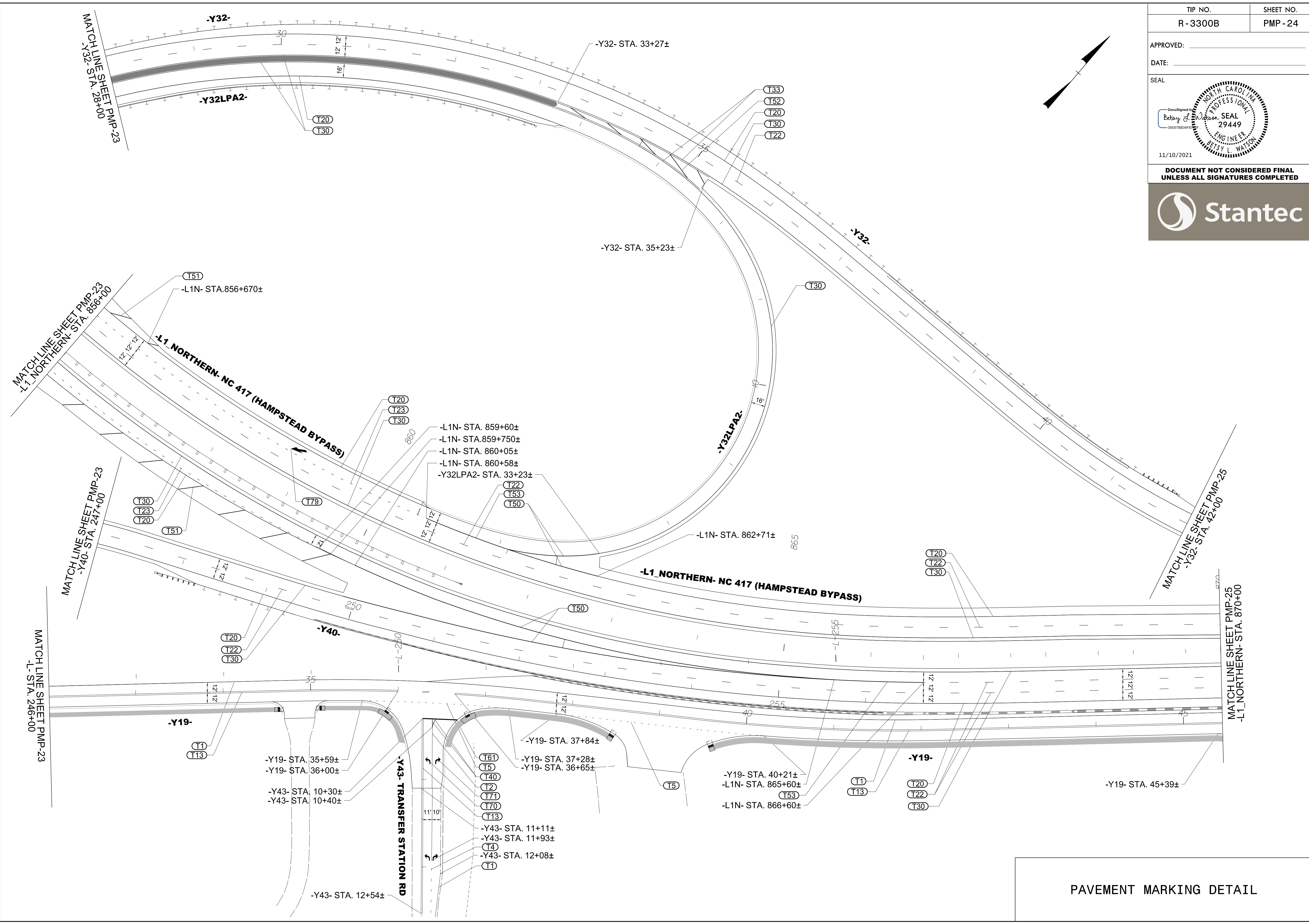

PAVEMENT MARKING DETAIL

TIP NO. R-3300B	SHEET NO. PMP-24
APPROVED: _____	
DATE: _____	
SEAL	
11/10/2021	
DOCUMENT NOT CONSIDERED FINAL UNLESS ALL SIGNATURES COMPLETED	

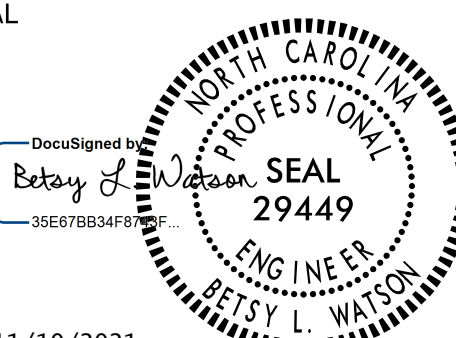

9/13/2021
 U:\Traffic\Signing\CADD\pmp\plan_sheets\R-3300B_pmp_24.dgn
 arngood

PAVEMENT MARKING DETAIL

TIP NO. R-3300B	SHEET NO. PMP-25
APPROVED: _____	
DATE: _____	
SEAL	
	
11/10/2021	
DOCUMENT NOT CONSIDERED FINAL UNLESS ALL SIGNATURES COMPLETED	
	

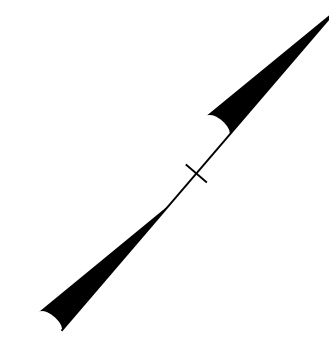

270

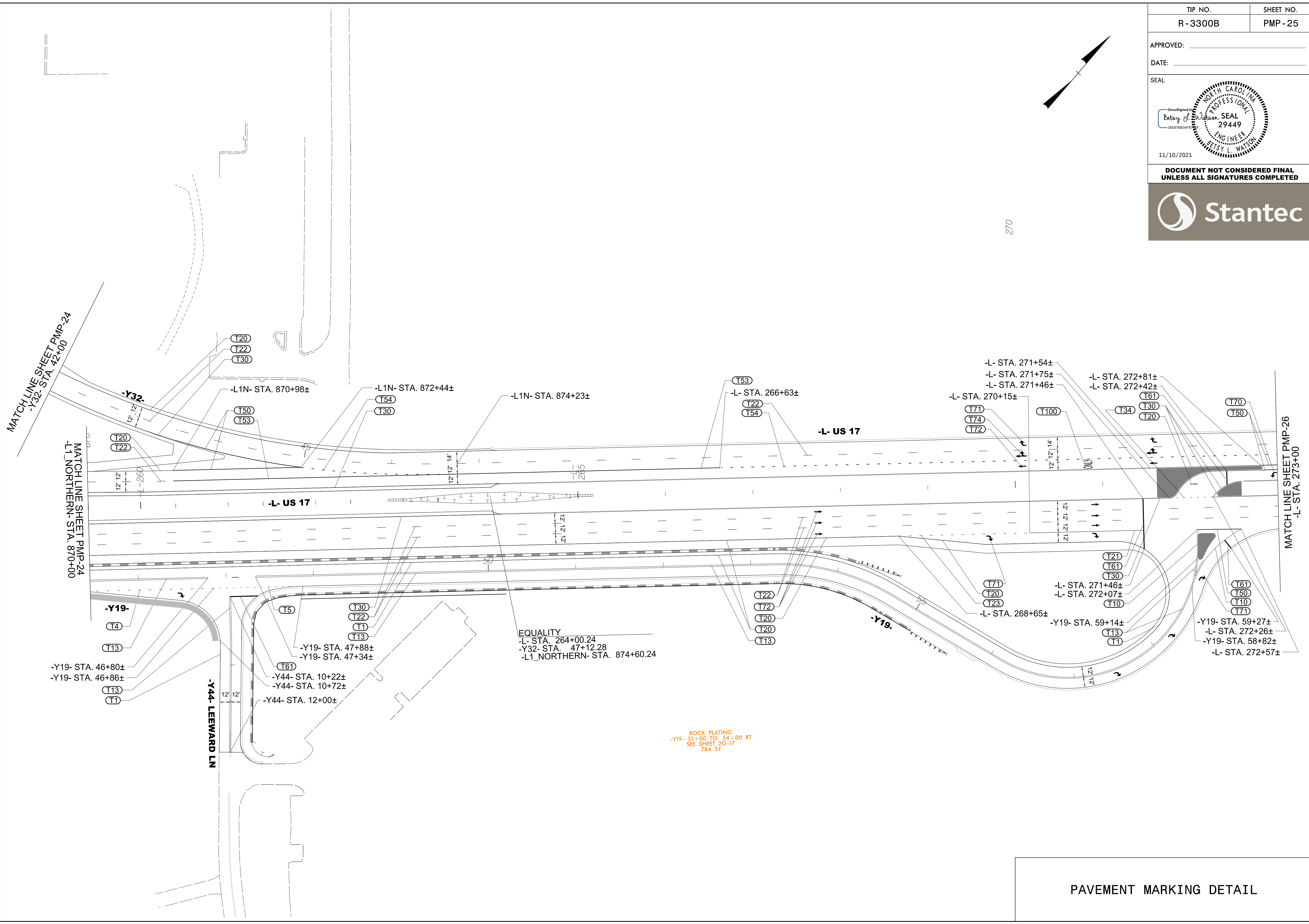

9/13/2021
U:\Traffic\Signing\CADD\pmp\plan sheets\R-3300B_pmp_25.dgn
angood

PAVEMENT MARKING DETAIL

TIP NO.	SHEET NO.
R-3300B	PMP-26

APPROVED: _____
 DATE: _____

SEAL

11/10/2021

**DOCUMENT NOT CONSIDERED FINAL
 UNLESS ALL SIGNATURES COMPLETED**

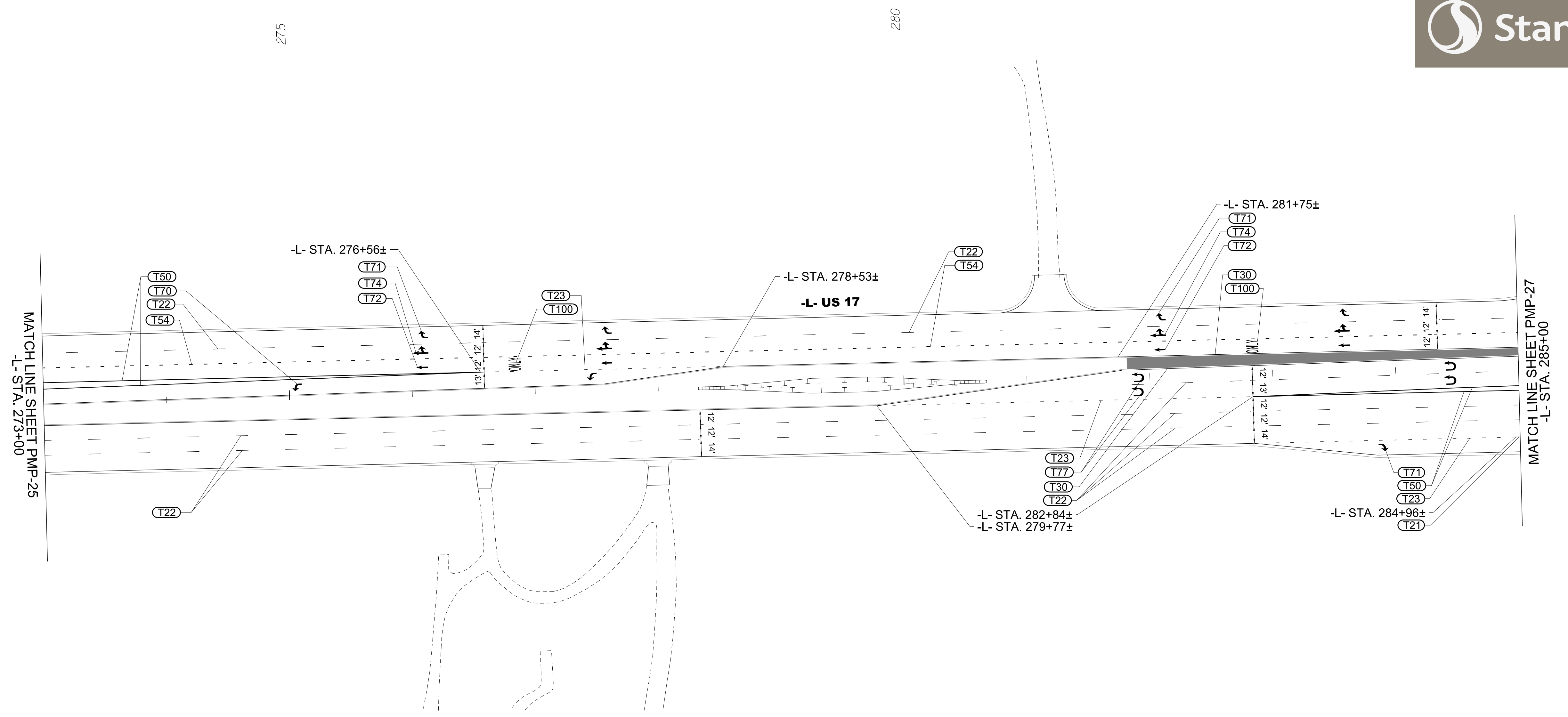
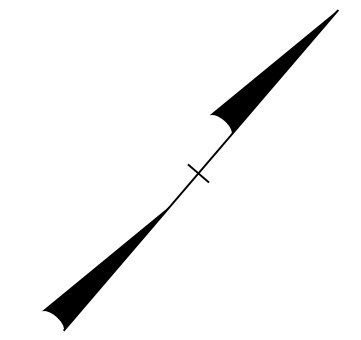

9/13/2021
 UsTraffic\Signing\CADD\pmp\plan_sheets\R-3300B_pmp_26.dgn
 arngood

PAVEMENT MARKING DETAIL

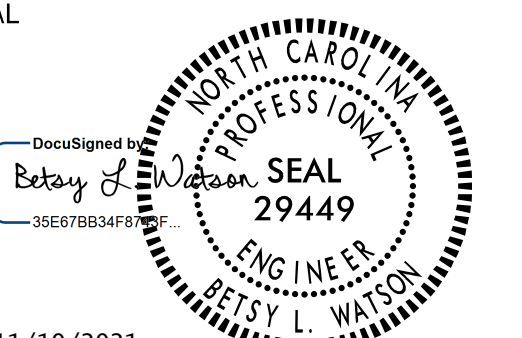
TIP NO. R-3300B	SHEET NO. PMP-27
APPROVED: _____	
DATE: _____	
SEAL	
	
11/10/2021	
DOCUMENT NOT CONSIDERED FINAL UNLESS ALL SIGNATURES COMPLETED	

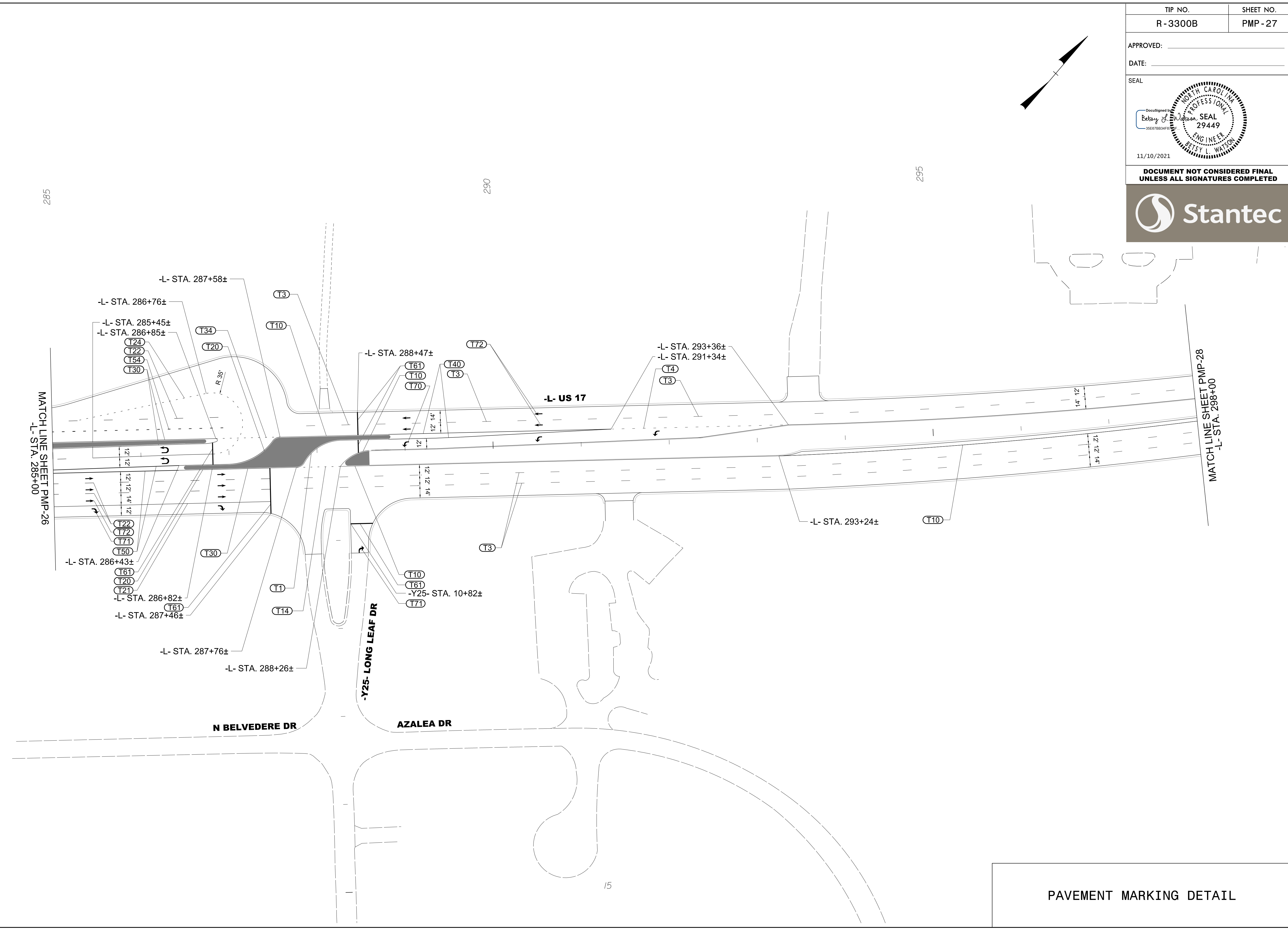

9/13/2021
 U:\Traffic\Signing\CADD\PM\plan_sheets\R-3300B_pmp_27.dgn
 arngood

PAVEMENT MARKING DETAIL

TIP NO. R-3300B	SHEET NO. PMP-28
APPROVED: _____	
DATE: _____	
SEAL	
	
11/10/2021	
DOCUMENT NOT CONSIDERED FINAL UNLESS ALL SIGNATURES COMPLETED	
	

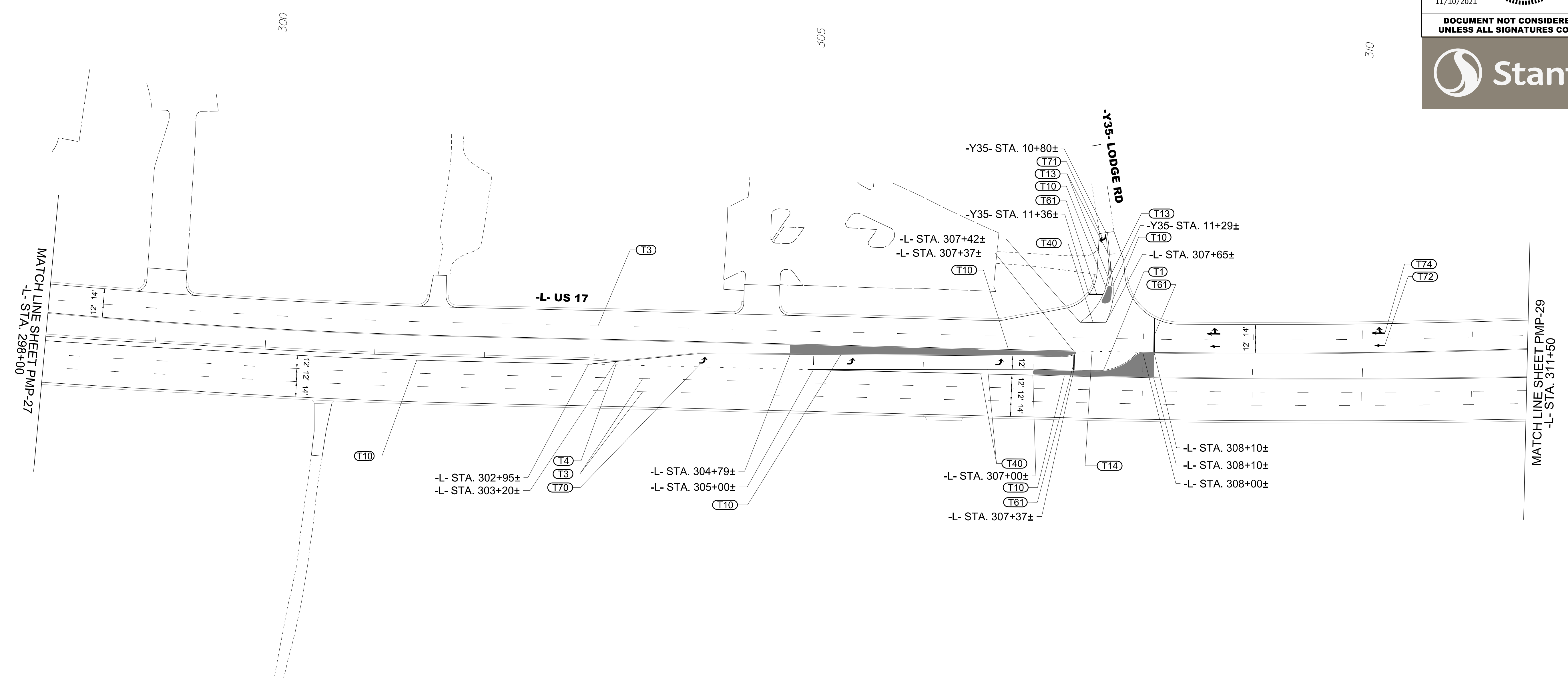
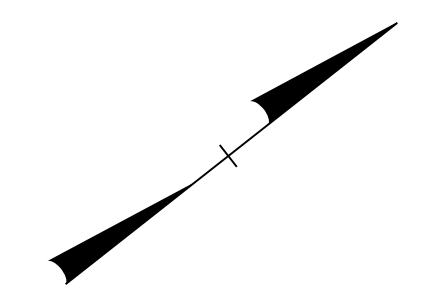

9/13/2021
 UsTraffic\Signing\CADD\pmp\plan_sheets\R-3300B_pmp_28.dgn
 arngood

PAVEMENT MARKING DETAIL

TIP NO. R-3300B	SHEET NO. PMP-29
APPROVED: _____	
DATE: _____	
SEAL	
<p>11/10/2021</p> <p>DOCUMENT NOT CONSIDERED FINAL UNLESS ALL SIGNATURES COMPLETED</p>	

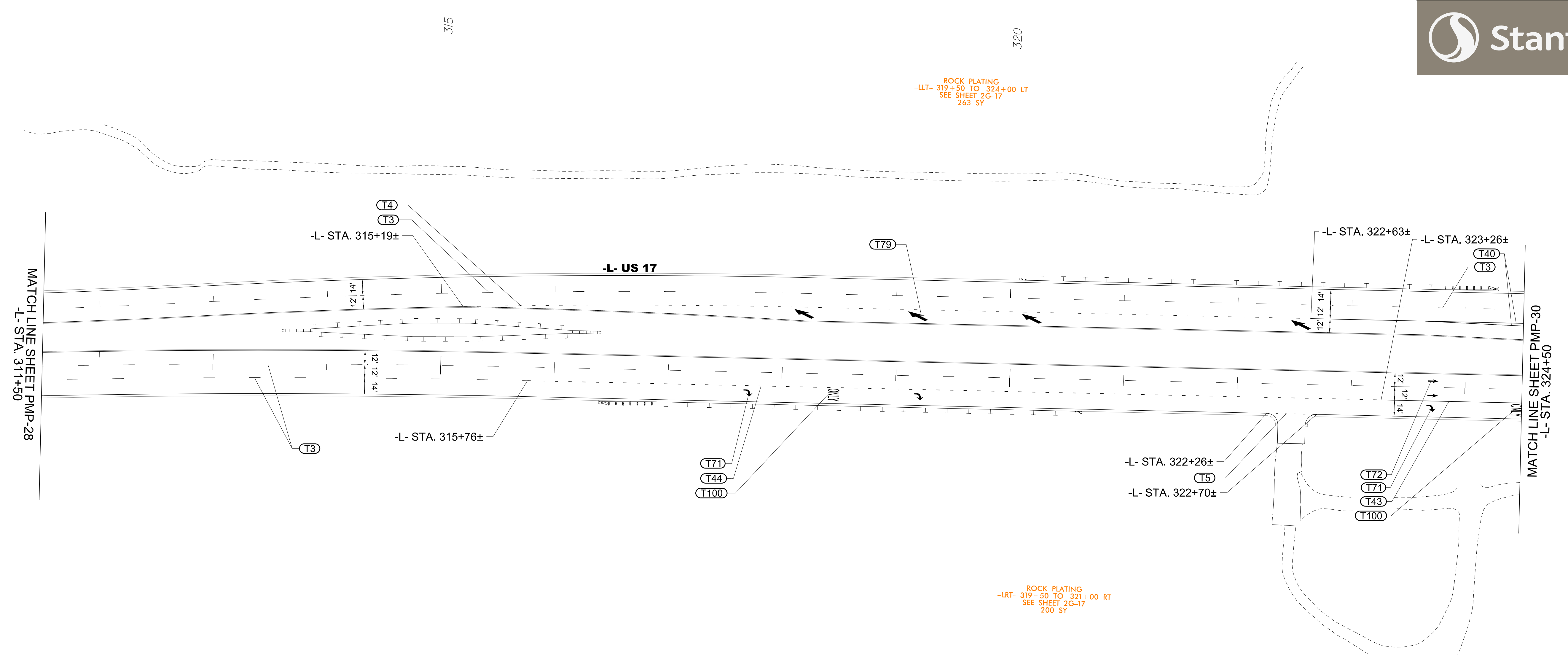
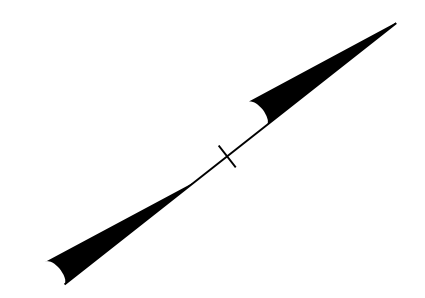

9/13/2021
 Us:\Traffic\Signing\CADD\PM\plan_sheets\R-3300B_pmp_29.dgn
 arngood

PAVEMENT MARKING DETAIL

APPROVED: _____
DATE: _____

SEAL

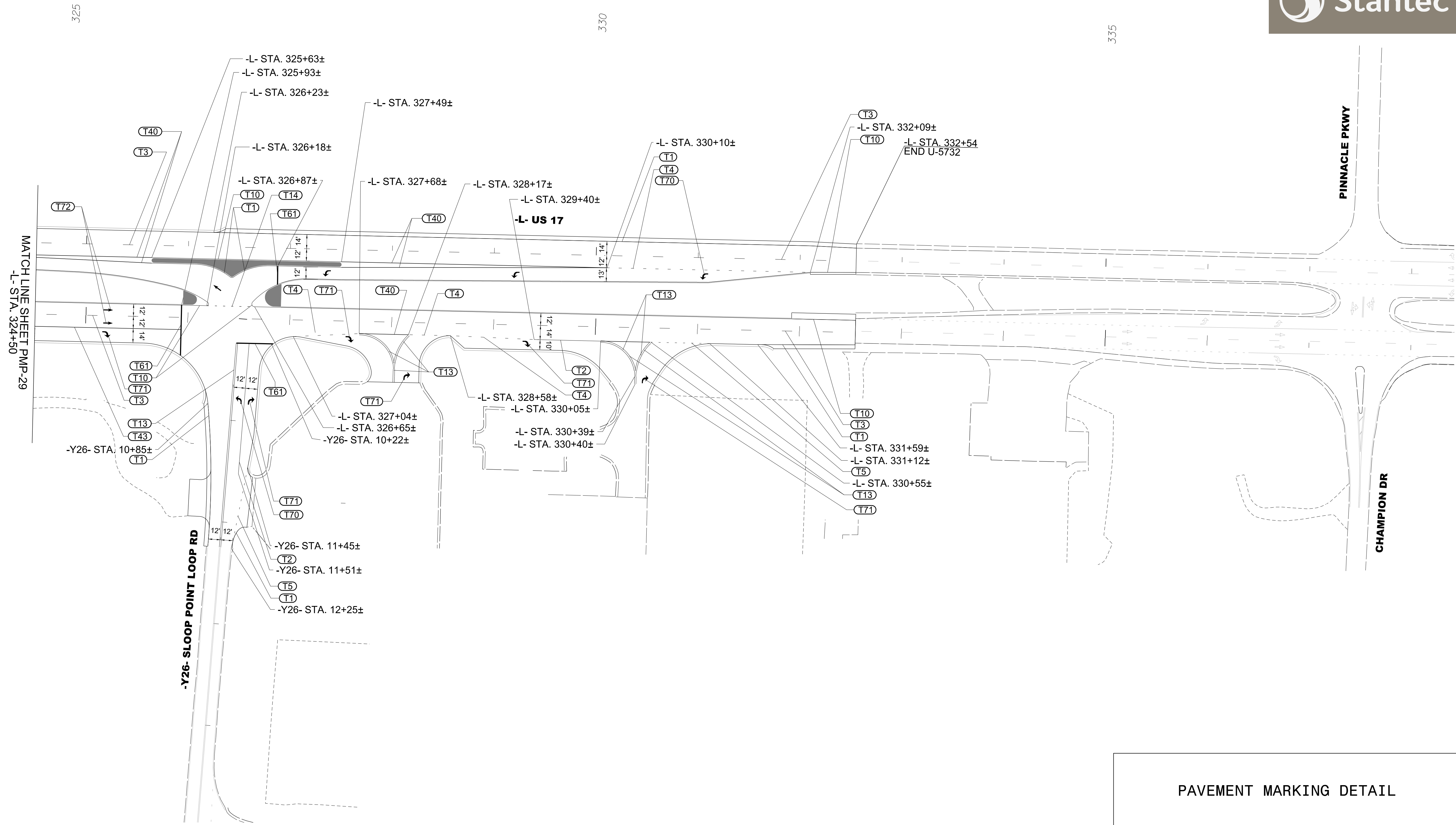
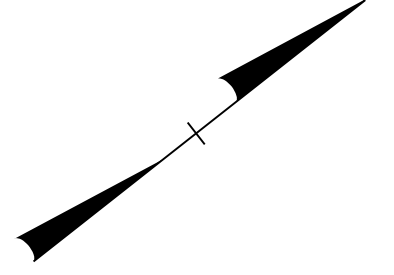

11/10/2021

DOCUMENT NOT CONSIDERED FINAL
UNLESS ALL SIGNATURES COMPLETED

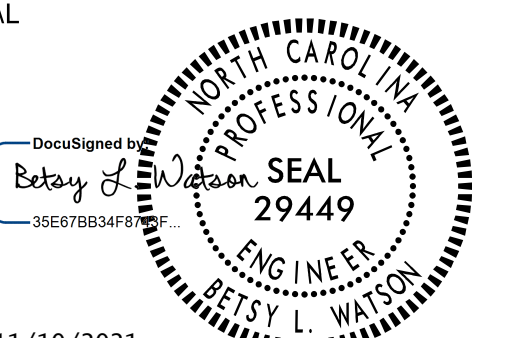

9/13/2021
U:\Traffic\Signing\CADD\PMP\plan_sheets\R-3300B_pmp_30.dgn
angood

PAVEMENT MARKING DETAIL

TIP NO. R-3300B	SHEET NO. PMP-31
APPROVED: _____	
DATE: _____	
SEAL	
	
11/10/2021	
DOCUMENT NOT CONSIDERED FINAL UNLESS ALL SIGNATURES COMPLETED	
	

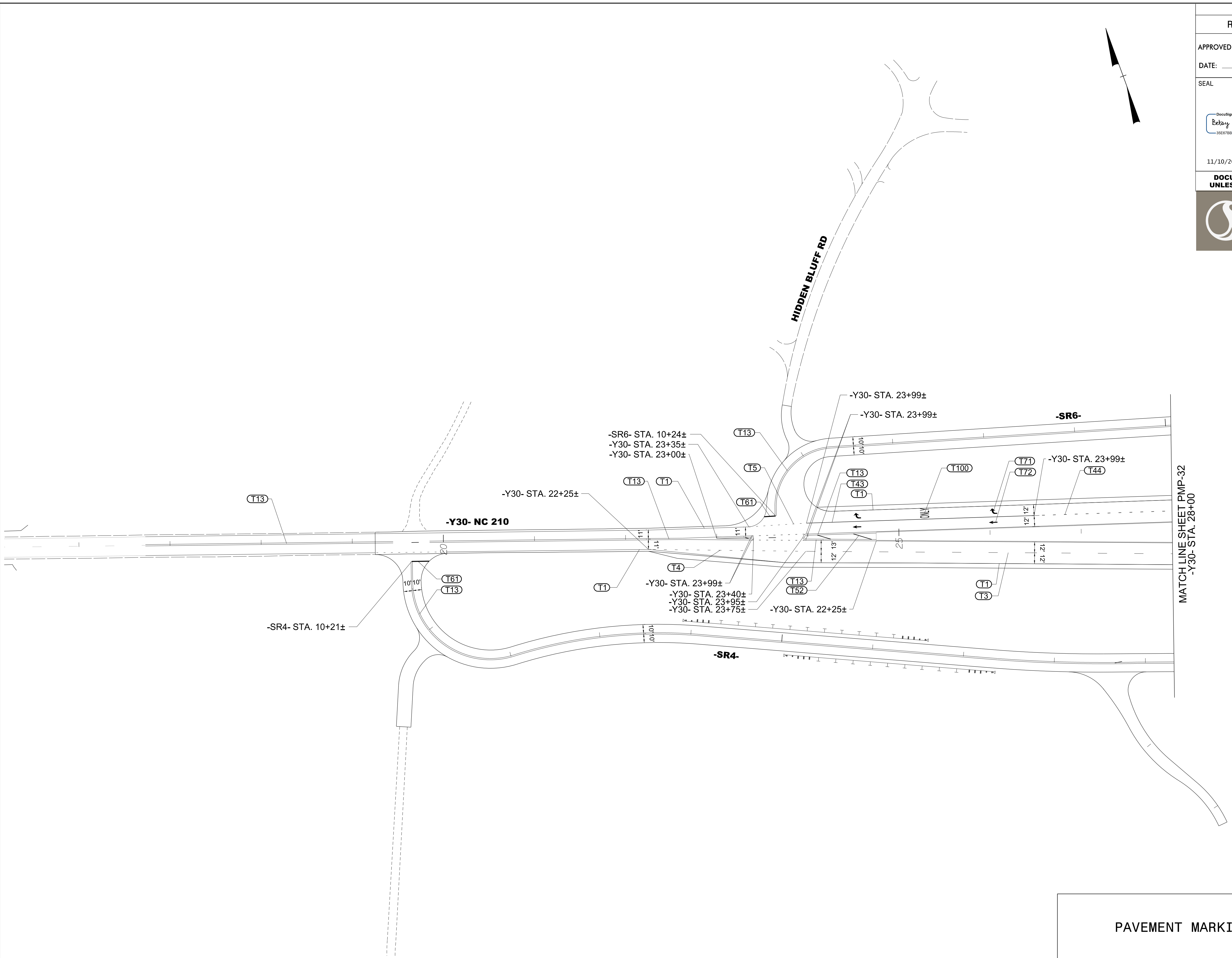
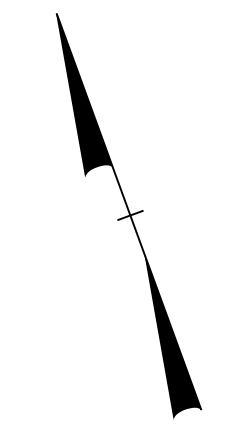

9/13/2021
U:\Traffic\Signing\CADD\pmp\plan_sheets\R-3300B_pmp_31.dgn
angood

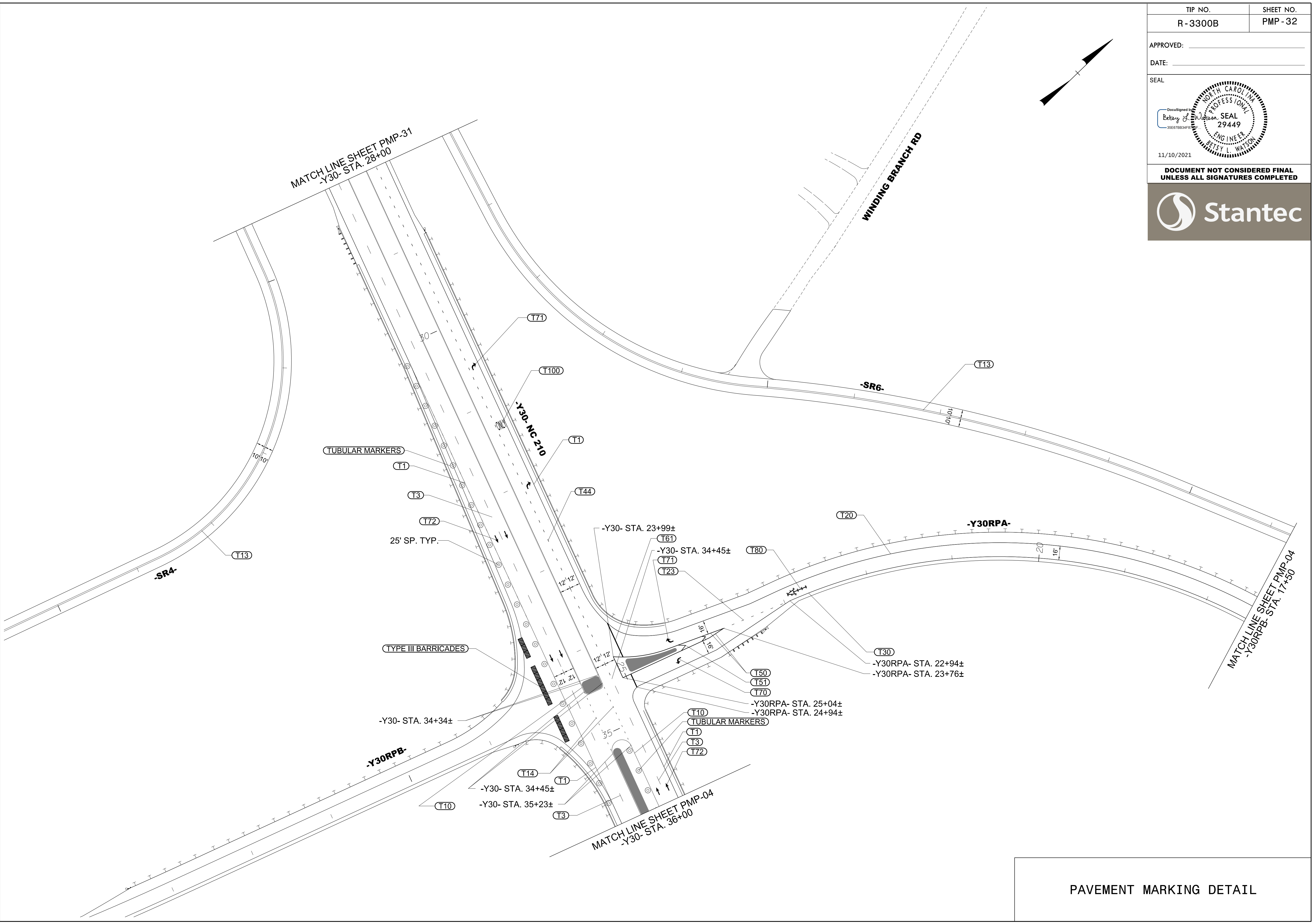
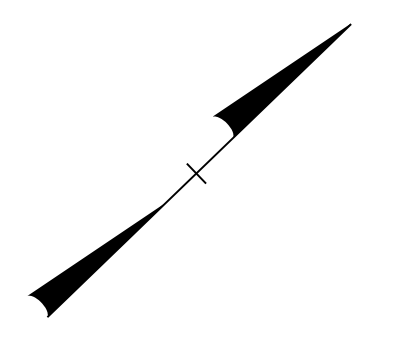

PAVEMENT MARKING DETAIL

TIP NO. R-3300B	SHEET NO. PMP-32
APPROVED: _____	
DATE: _____	
SEAL	
<p>11/10/2021</p> <p>DOCUMENT NOT CONSIDERED FINAL UNLESS ALL SIGNATURES COMPLETED</p>	



9/13/2021
U:\Traffic\Signing\CADD\pmp\plan_sheets\R-3300B_pmp_32.dgn
angood

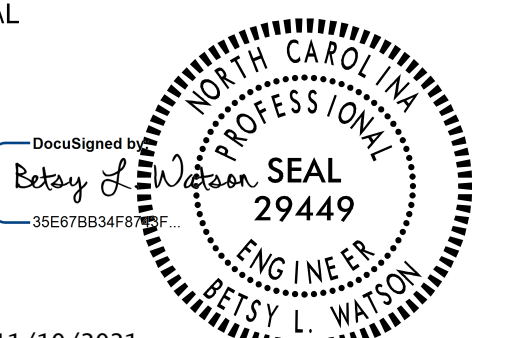

PAVEMENT MARKING DETAIL

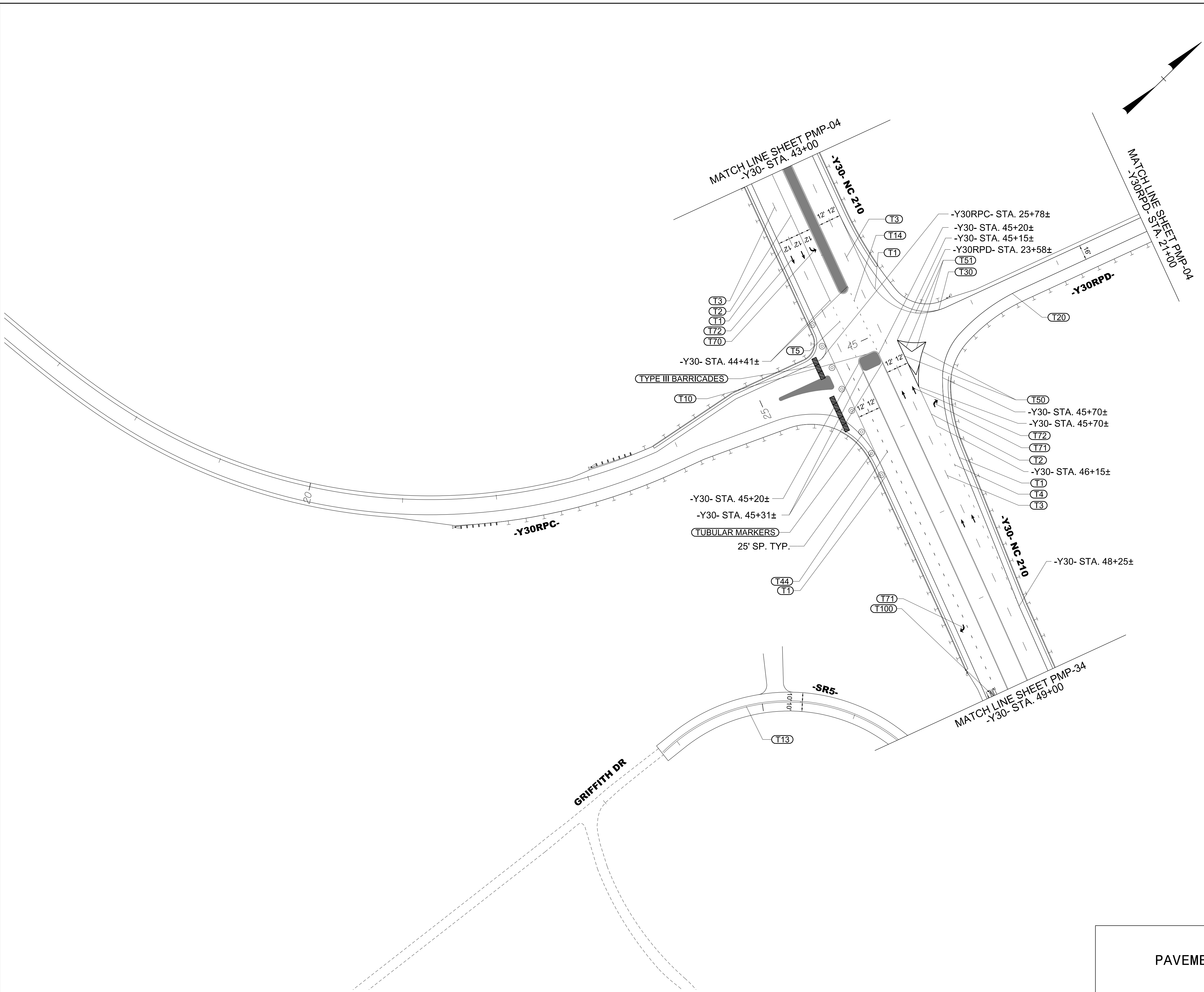
TIP NO. R-3300B	SHEET NO. PMP-33
APPROVED: _____	
DATE: _____	
SEAL	
	
11/10/2021	
DOCUMENT NOT CONSIDERED FINAL UNLESS ALL SIGNATURES COMPLETED	
	

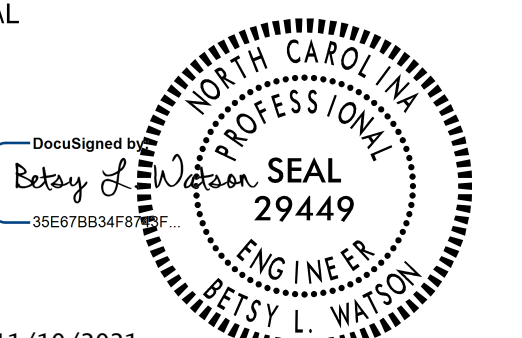

9/13/2021
U:\Traffic\Signing\CADD\PM\plan_sheets\R-3300B_pmp_33.dgn
angood

PAVEMENT MARKING DETAIL

TIP NO. R-3300B	SHEET NO. PMP-34
APPROVED: _____	
DATE: _____	
SEAL	
	
11/10/2021	
DOCUMENT NOT CONSIDERED FINAL UNLESS ALL SIGNATURES COMPLETED	
	

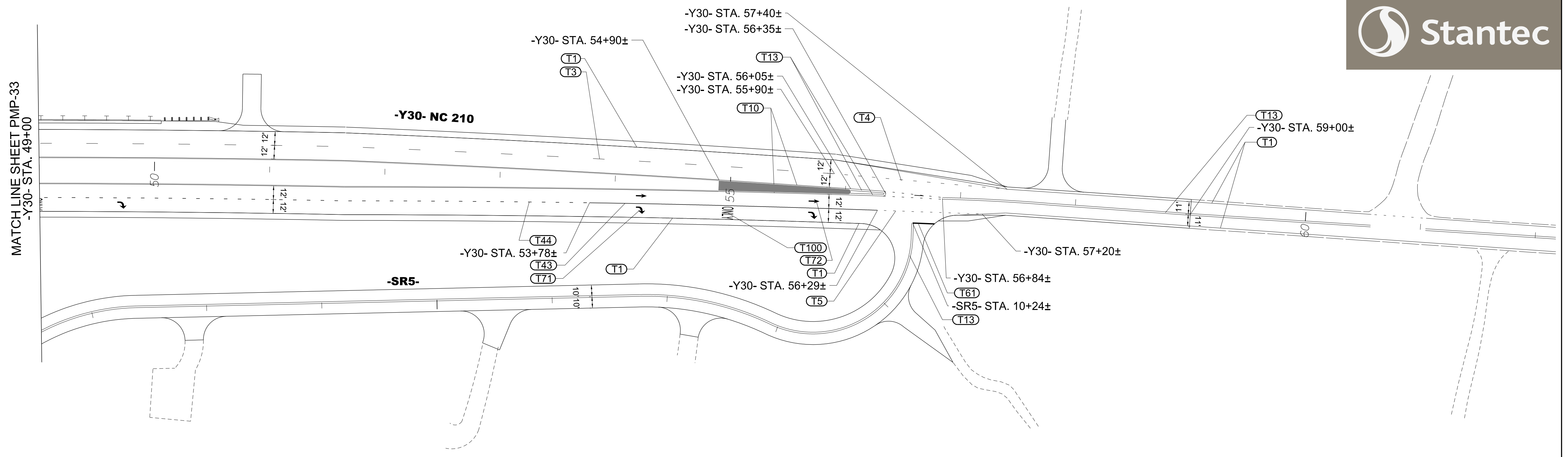
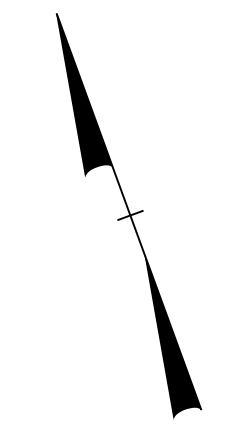

9/13/2021
U:\Traffic\Signing\CADD\PM\plan_sheets\R-3300B_pmp_34.dgn
angood

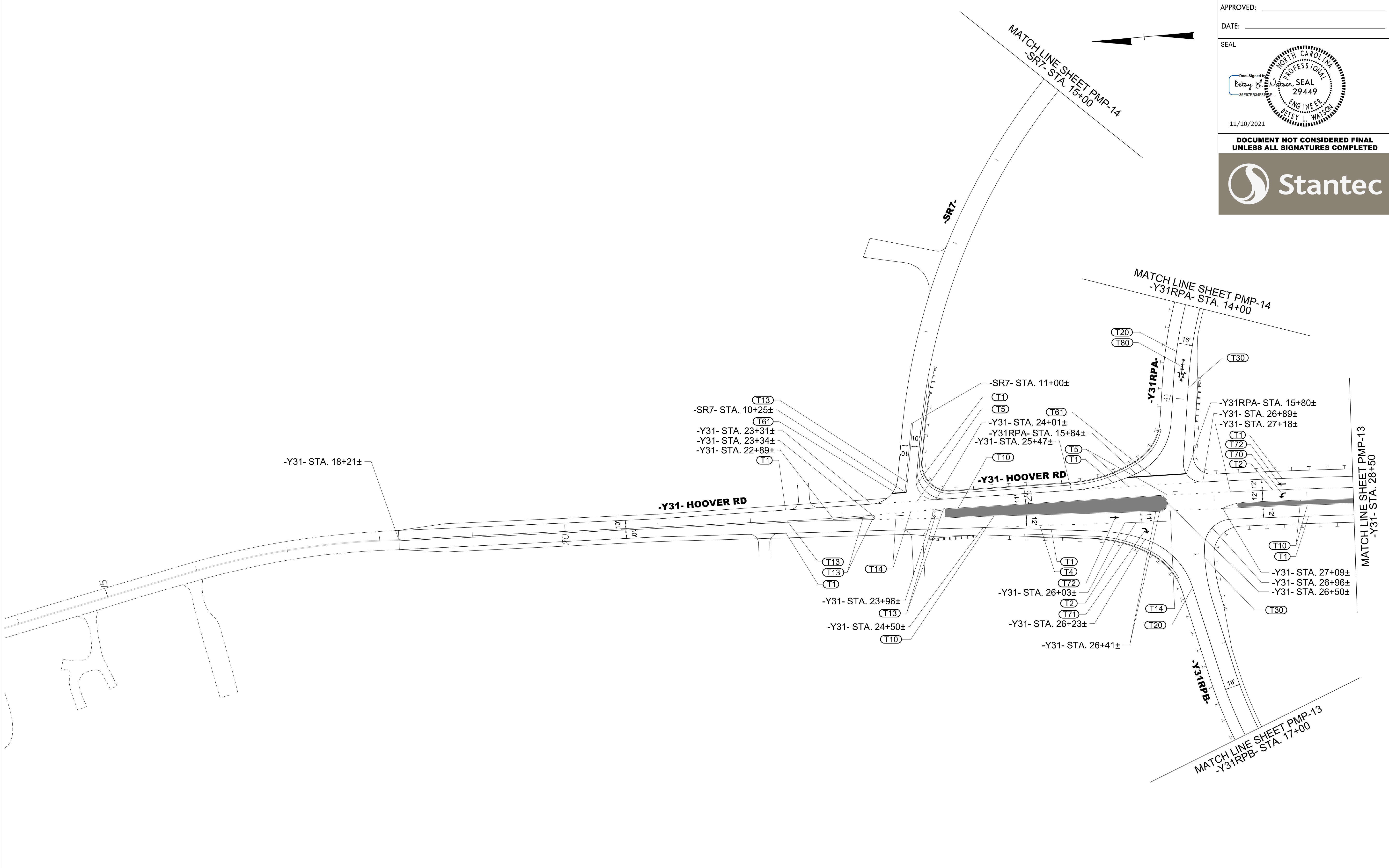

PAVEMENT MARKING DETAIL

TIP NO. R-3300B	SHEET NO. PMP-35
APPROVED: _____	
DATE: _____	
SEAL	
<p>DOCUMENT NOT CONSIDERED FINAL UNLESS ALL SIGNATURES COMPLETED</p>	

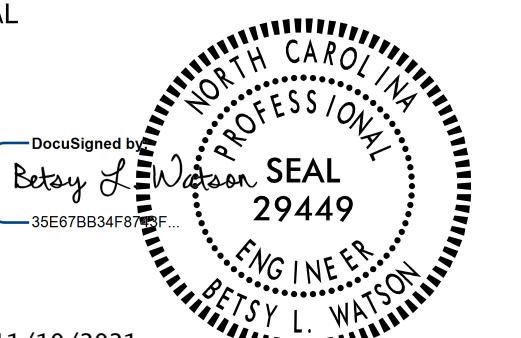

9/13/2021
U:\Traffic\Signing\CADD\pmp\plan_sheets\R-3300B_pmp_35.dgn
angood

PAVEMENT MARKING DETAIL

TIP NO. R-3300B	SHEET NO. PMP-37
APPROVED: _____	
DATE: _____	
SEAL	
	
11/10/2021	
DOCUMENT NOT CONSIDERED FINAL UNLESS ALL SIGNATURES COMPLETED	
	

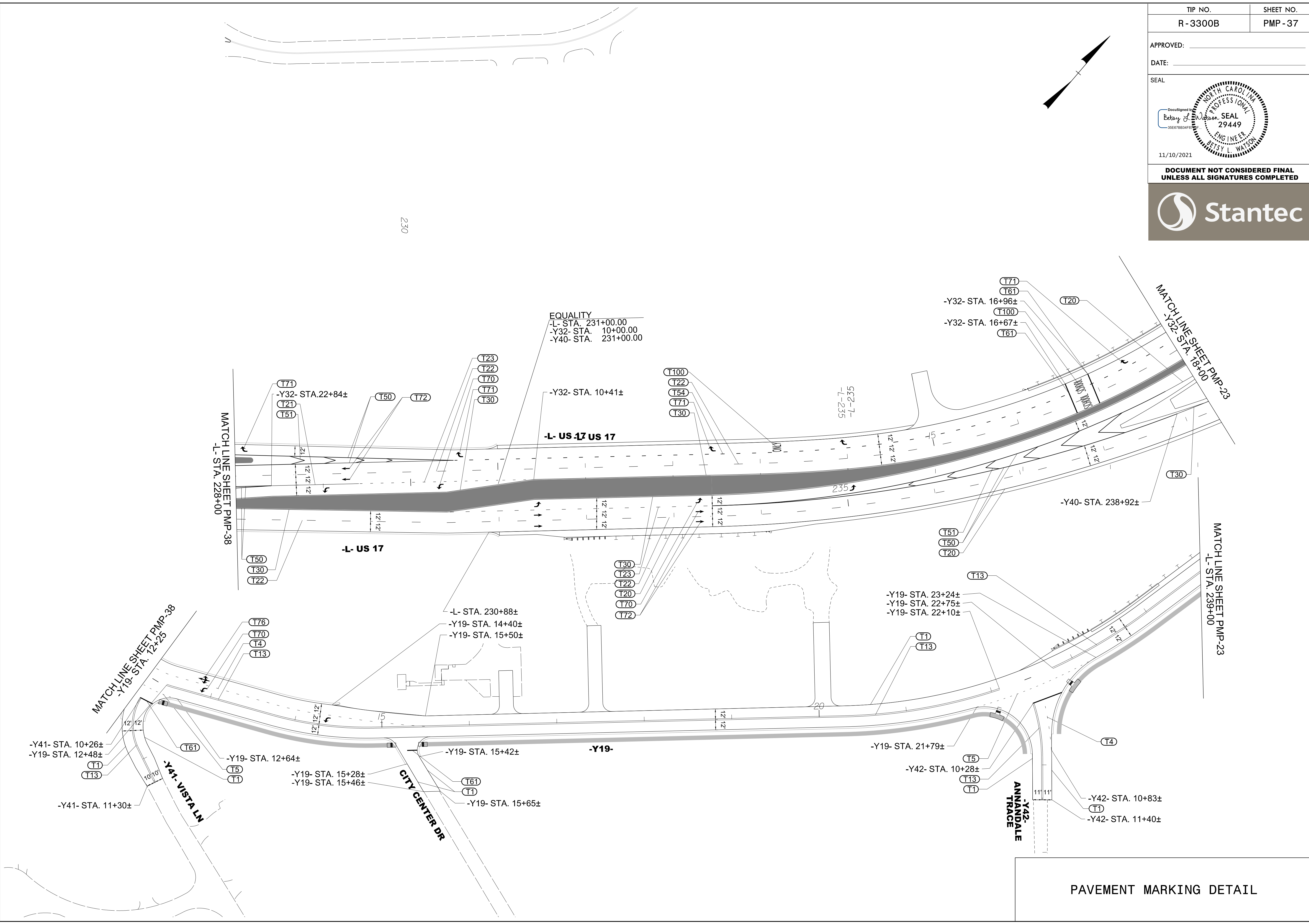
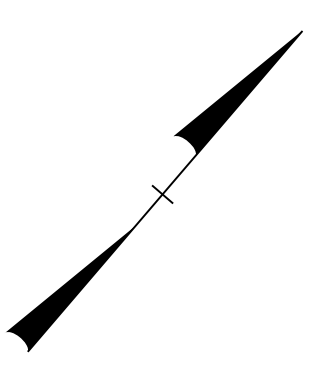

9/13/2021
 U:\Traffic\Signing\CADD\PMP\plan_sheets\R-3300B_pmp_37.dgn
 arngood

PAVEMENT MARKING DETAIL

TIP NO. R-3300B	SHEET NO. PMP-38
APPROVED: _____	
DATE: _____	
SEAL	
11/10/2021	
DOCUMENT NOT CONSIDERED FINAL UNLESS ALL SIGNATURES COMPLETED	

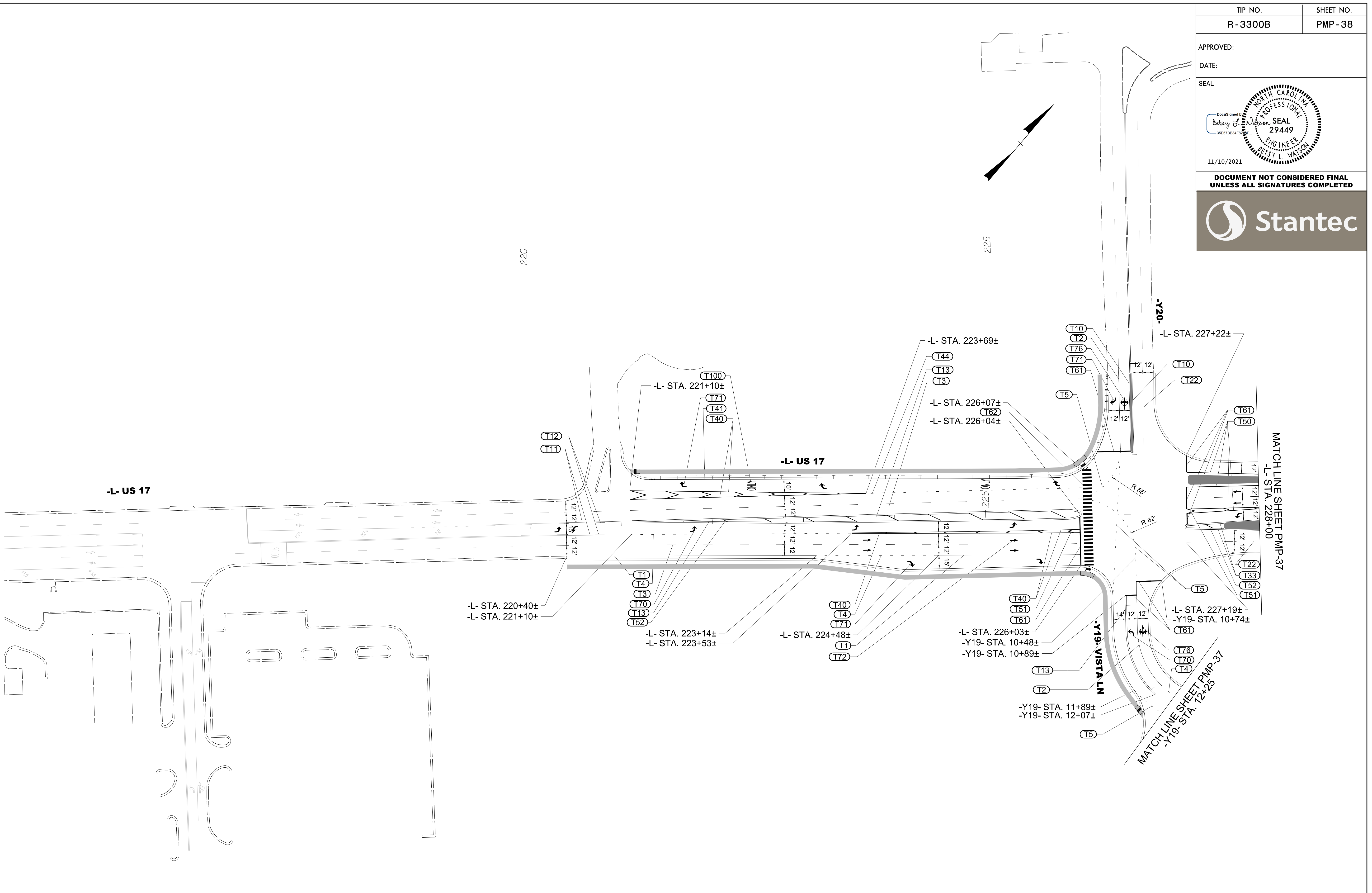

9/13/2021
 Us:\Traffic\Signing\CADD\pmp\plan_sheets\R-3300B_pmp_38.dgn
 andgood

PAVEMENT MARKING DETAIL