

9/24/2021
 U:\Traffic\Transportation Management Plan\TCP\PLAN SHEETS\VR-3300B\TMP_61\AREA 5_PHASE 2_STEP 2.dgn
 angood

 Stantec Consulting Services Inc.
 801 Jones Franklin Road
 Suite 300
 Raleigh, NC 27606
 Tel. 919.851.6866
 Fax. 919.851.7024
 www.stantec.com
 License No. F-0672

10/27/2021

**DOCUMENT NOT CONSIDERED FINAL
 UNLESS ALL SIGNATURES COMPLETED**

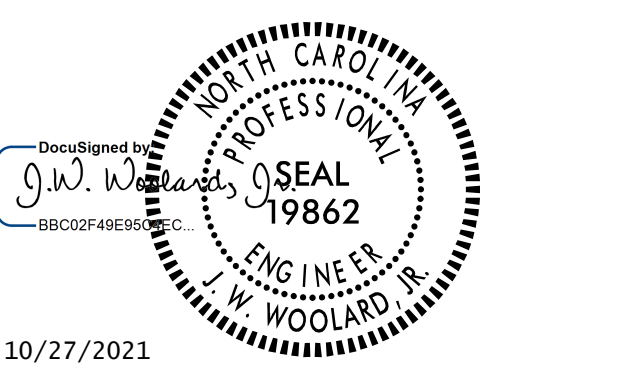
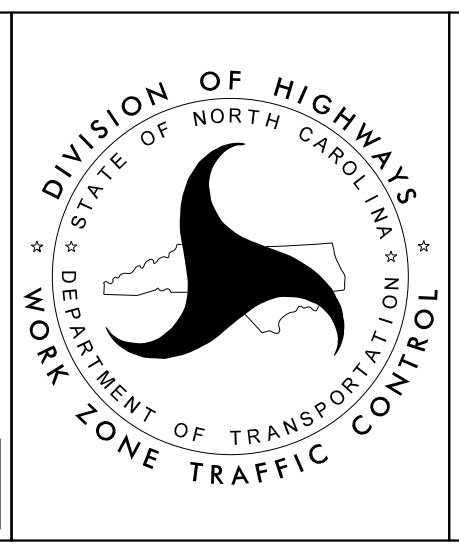

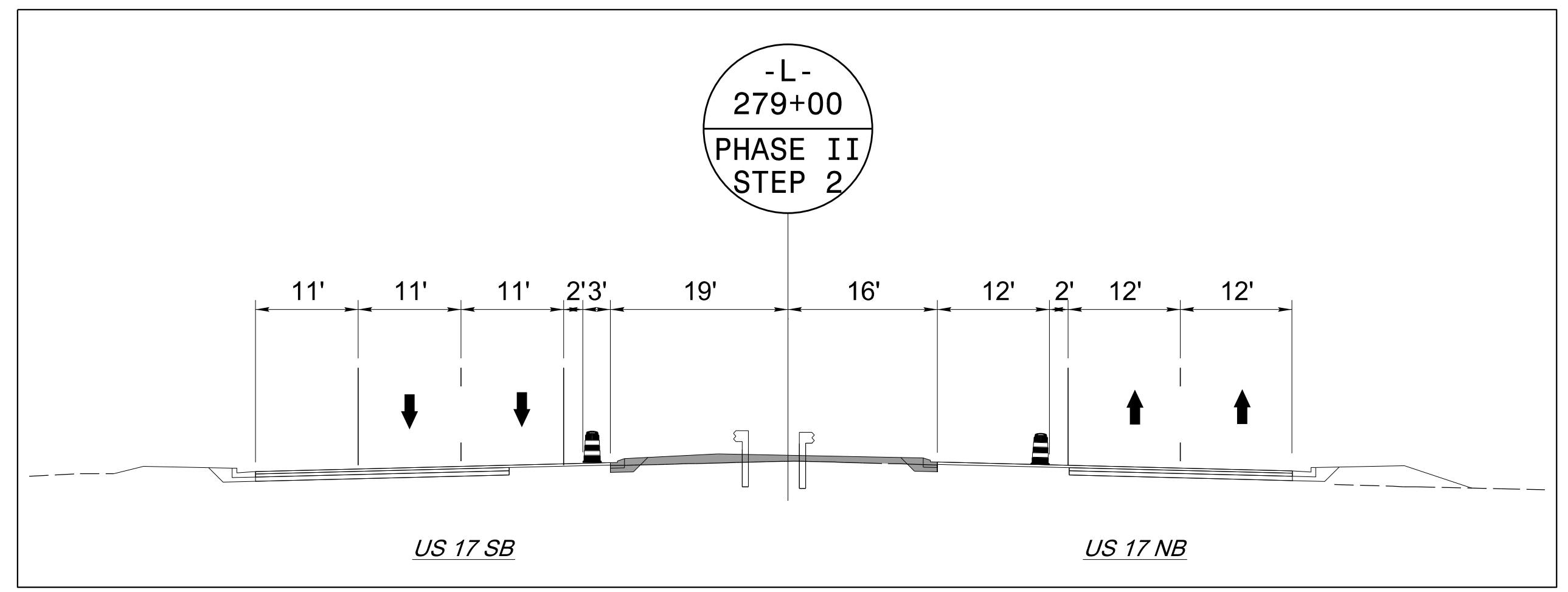
-L- / -Y32- / -Y40- / US-17
 AREA 5
 PHASE II
 STEP 2

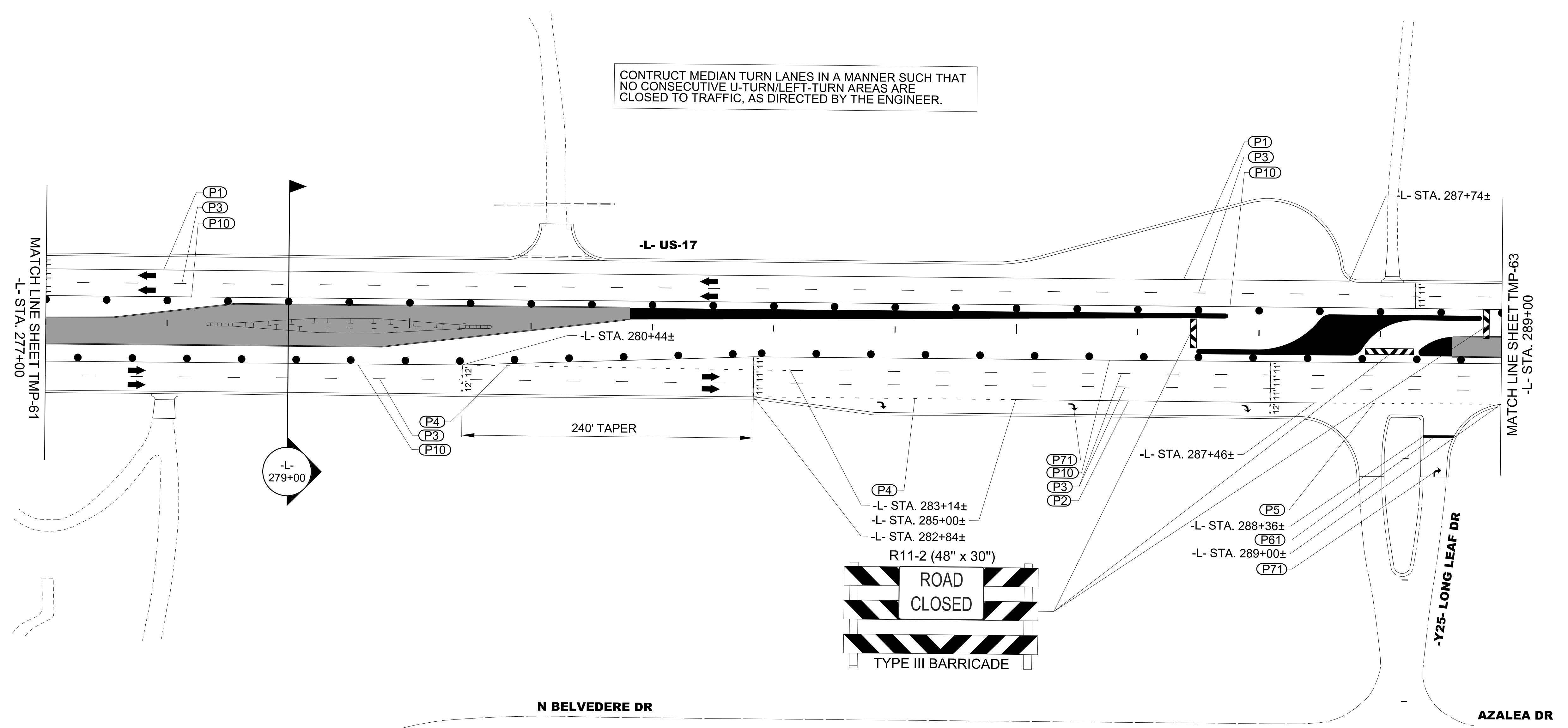

CONSTRUCT MEDIAN TURN LANES IN A MANNER SUCH THAT NO CONSECUTIVE U-TURN/LEFT-TURN AREAS ARE CLOSED TO TRAFFIC, AS DIRECTED BY THE ENGINEER.



9/13/2021
 U:\Traffic\Transportation Management\Plan\TCP\PLAN SHEETS\IR-3300B_TMP_62.AREA 5_PHASE 2_STEP 2.dgn
 angood

Stantec
 Stantec Consulting Services Inc.
 801 Jones Franklin Road
 Suite 300
 Raleigh, NC 27606
 Tel. 919.851.6866
 Fax. 919.851.7024
 www.stantec.com
 License No. F-0672

DocuSigned by:
 J.W. Woolard
 19862
 ENGINEER
 W. WOOLARD, R.
 10/27/2021
**DOCUMENT NOT CONSIDERED FINAL
 UNLESS ALL SIGNATURES COMPLETED**

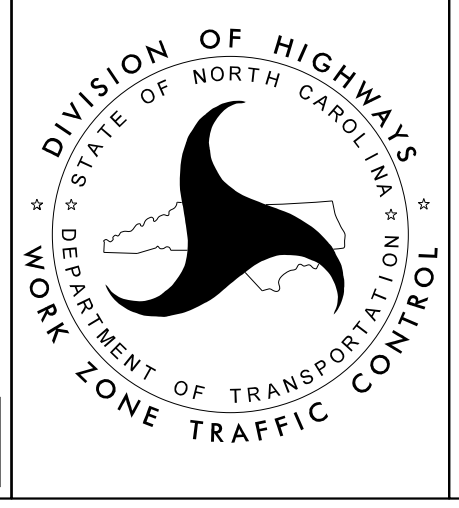

-L- / -Y32- / -Y40- / US-17
 AREA 5
 PHASE II
 STEP 2

PROJ. REFERENCE NO.	SHEET NO.
R-3300B	TMP-63

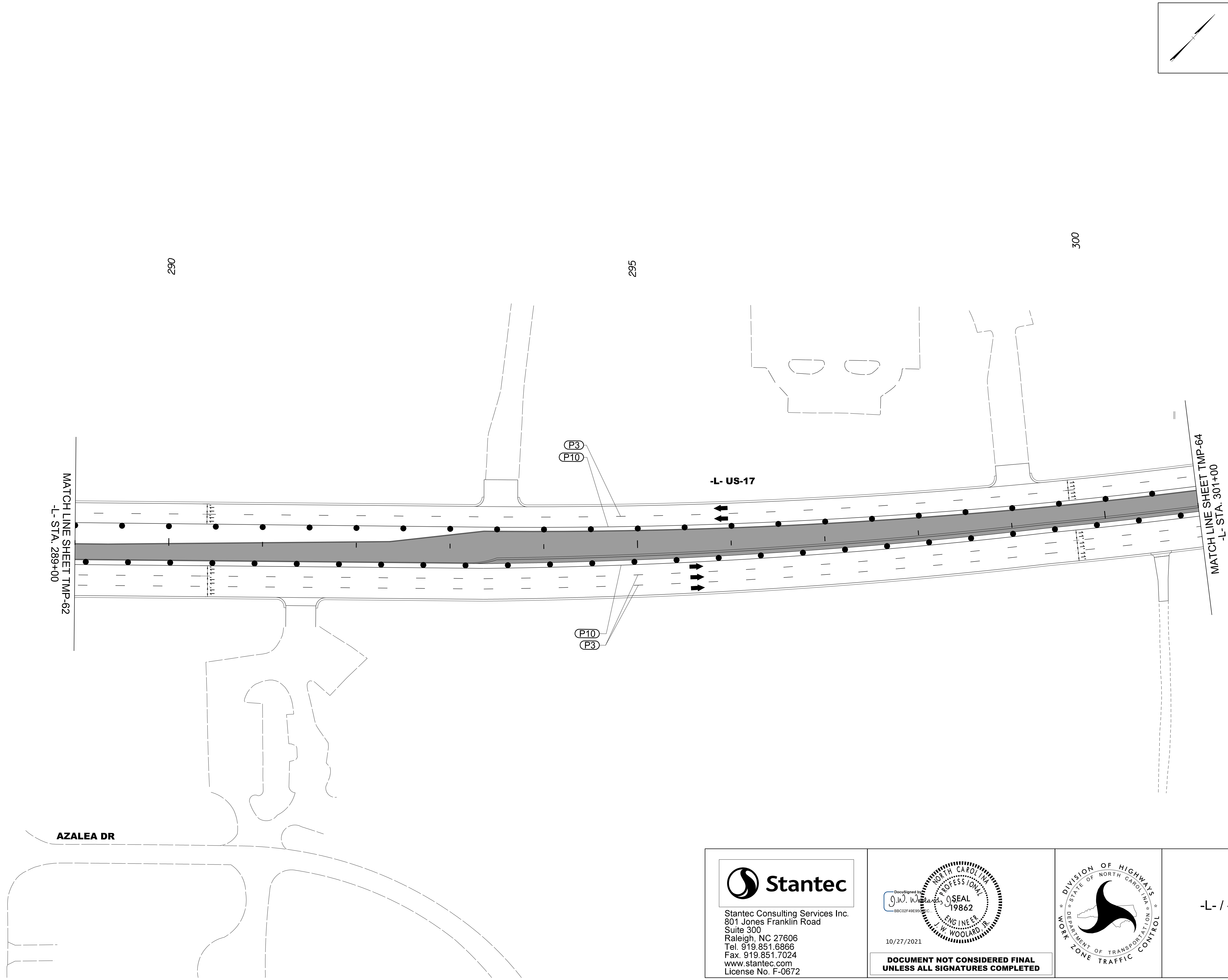
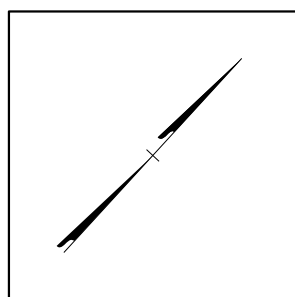

9/13/2021
 U:\Traffic\Transportation Management\Plan\TCP\PLAN SHEETS\IR-3300B_TMP_63_AREA 5_PHASE 2_STEP 2.dgn
 angood

 Stantec Consulting Services Inc.
 801 Jones Franklin Road
 Suite 300
 Raleigh, NC 27606
 Tel. 919.851.6866
 Fax. 919.851.7024
 www.stantec.com
 License No. F-0672

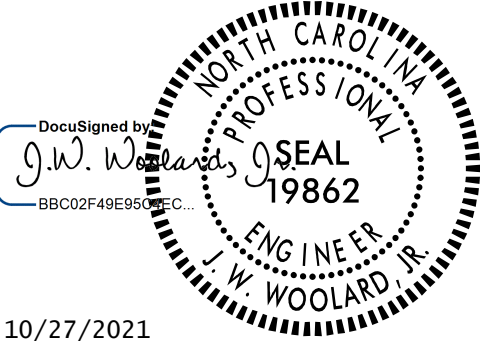
DocuSigned by:

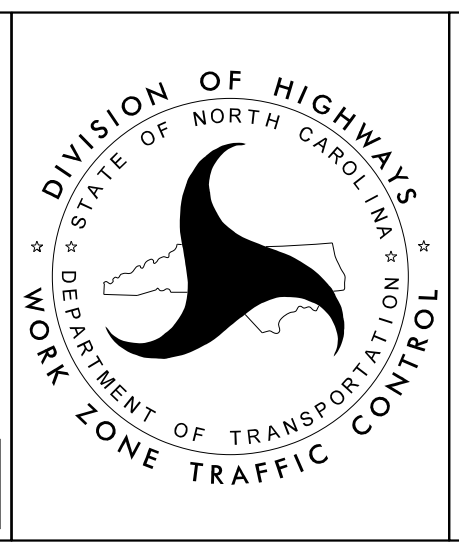
 10/27/2021
**DOCUMENT NOT CONSIDERED FINAL
 UNLESS ALL SIGNATURES COMPLETED**

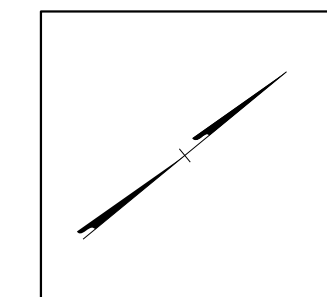

-L- / -Y32- / -Y40- / US-17
 AREA 5
 PHASE II
 STEP 2

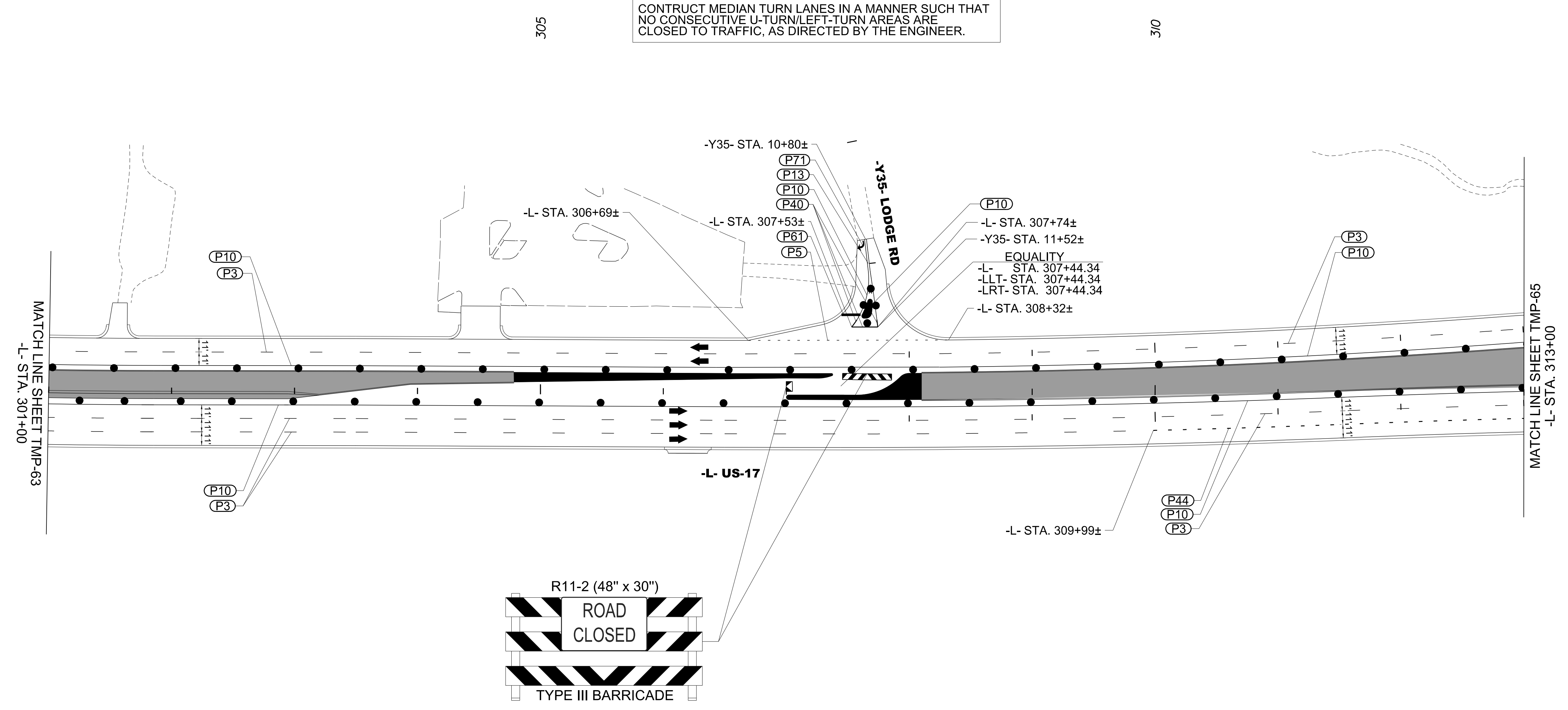

CONSTRUCT MEDIAN TURN LANES IN A MANNER SUCH THAT NO CONSECUTIVE U-TURN/LEFT-TURN AREAS ARE CLOSED TO TRAFFIC, AS DIRECTED BY THE ENGINEER.



9/13/2021
 U:\Traffic\Transportation Management\Plan\TCP\PLAN SHEETS\IR-3300B_TMP_64_AREA 5_PHASE 2_STEP 2.dgn
 angood

Stantec
 Stantec Consulting Services Inc.
 801 Jones Franklin Road
 Suite 300
 Raleigh, NC 27606
 Tel. 919.851.6866
 Fax. 919.851.7024
 www.stantec.com
 License No. F-0672

DocuSigned by:
 J.W. Woolard
 10/27/2021

PROFESSIONAL SEAL
 19862
 ENGINEER
 J. W. WOOLARD, R.

DOCUMENT NOT CONSIDERED FINAL UNLESS ALL SIGNATURES COMPLETED

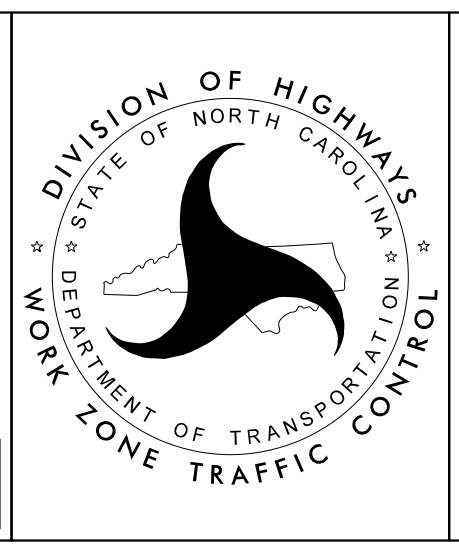

-L- / -Y32- / -Y40- / US-17
 AREA 5
 PHASE II
 STEP 2

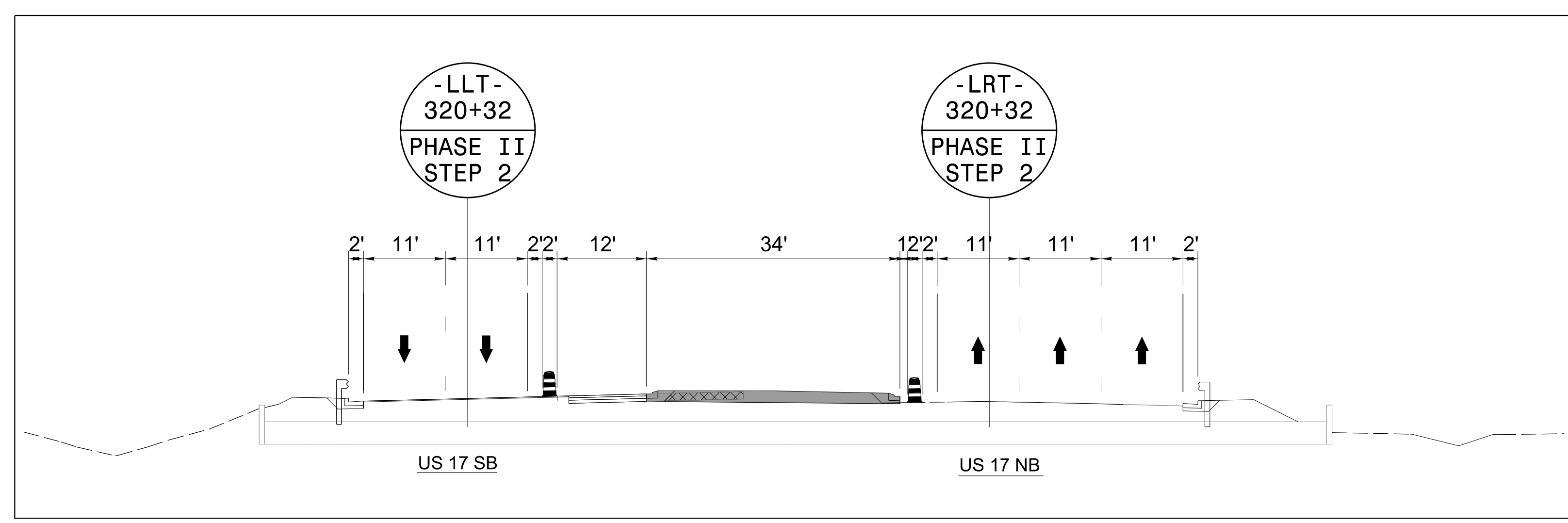
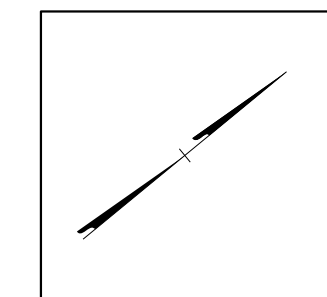

325

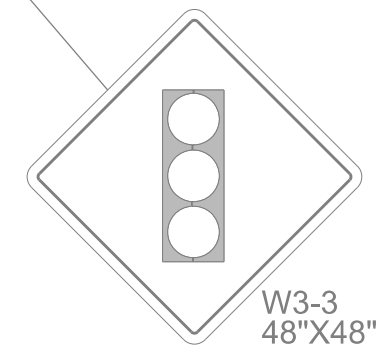
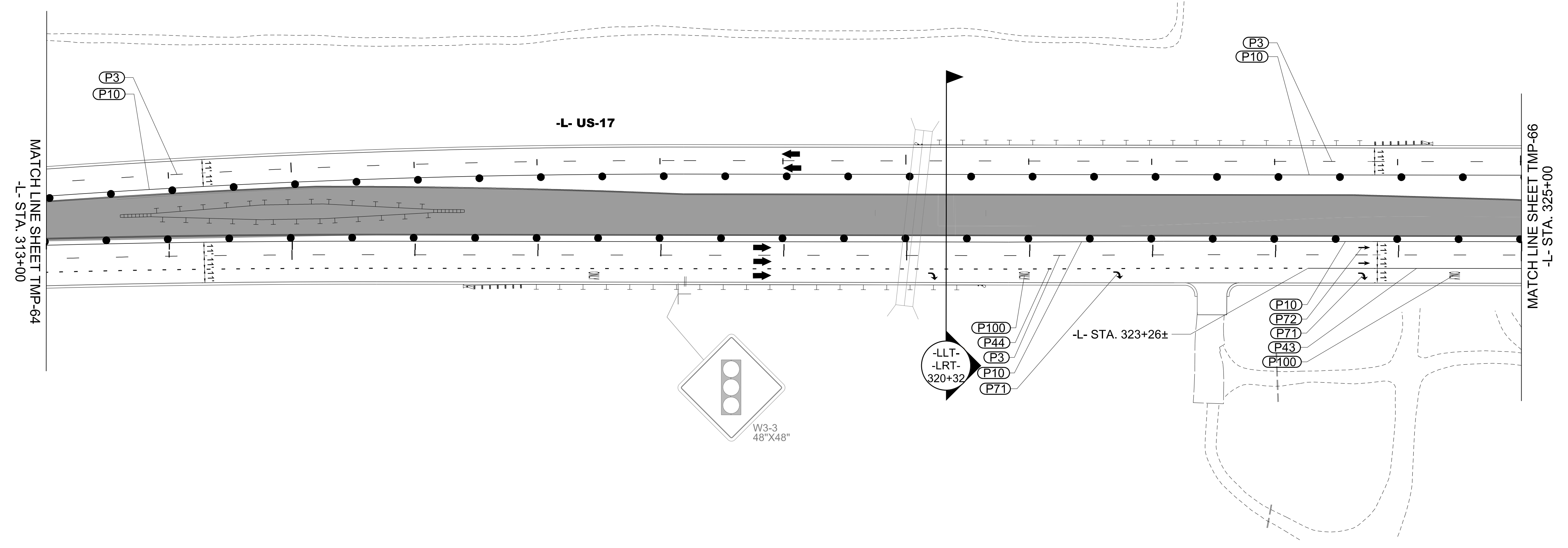

9/13/2021
U:\Traffic\Transportation Management\Plan\TCP\PLAN SHEETS\IR-3300B_TMP_65_AREA 5_PHASE 2_STEP 2.dgn
angood

Stantec Consulting Services Inc.
801 Jones Franklin Road
Suite 300
Raleigh, NC 27606
Tel. 919.851.6866
Fax. 919.851.7024
www.stantec.com
License No. F-0672

10/27/2021
**DOCUMENT NOT CONSIDERED FINAL
UNLESS ALL SIGNATURES COMPLETED**

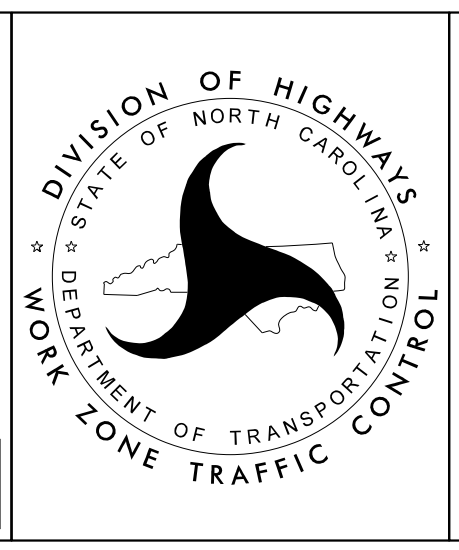

-L- / -Y32- / -Y40- / US-17
AREA 5
PHASE II
STEP 2

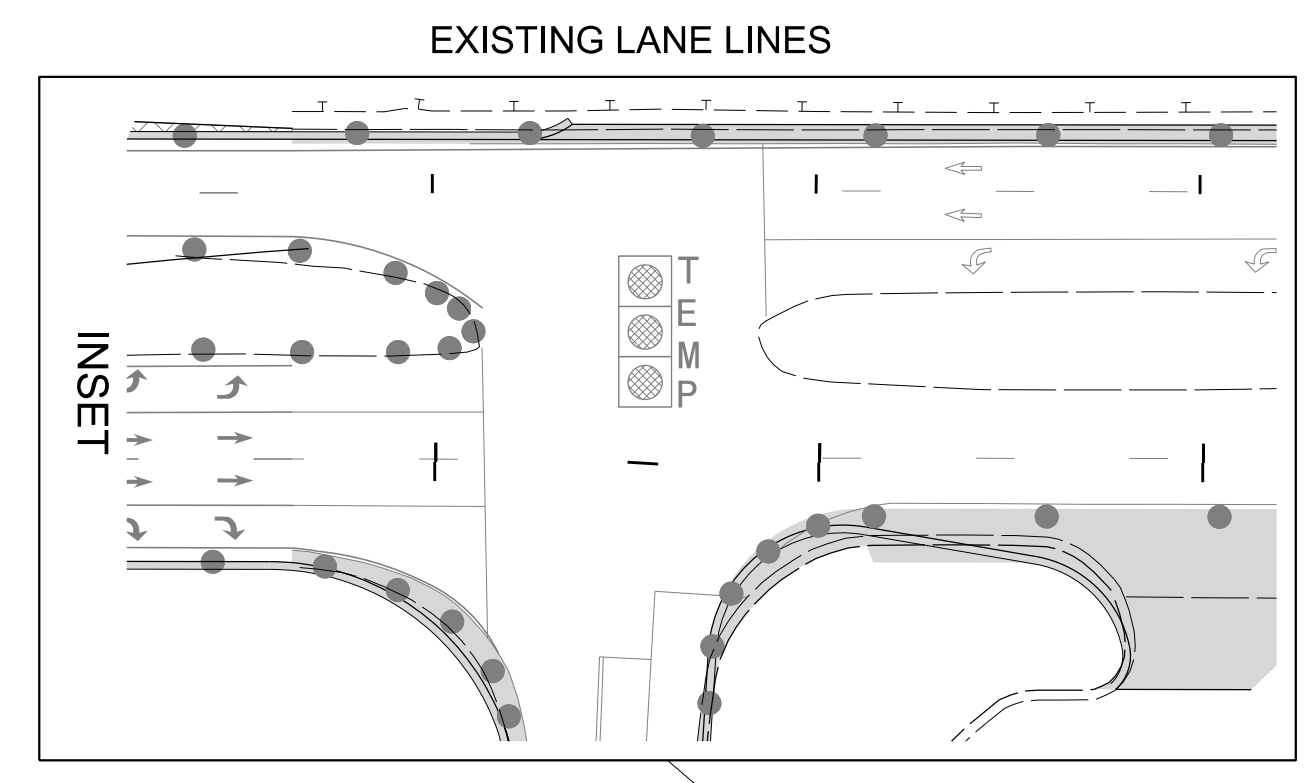
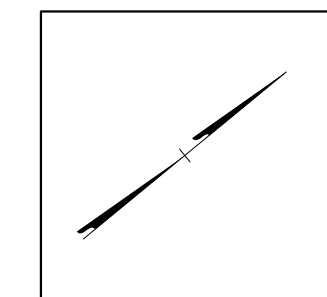

CONSTRUCT MEDIAN TURN LANES IN A MANNER SUCH THAT NO CONSECUTIVE U-TURN/LEFT-TURN AREAS ARE CLOSED TO TRAFFIC, AS DIRECTED BY THE ENGINEER.

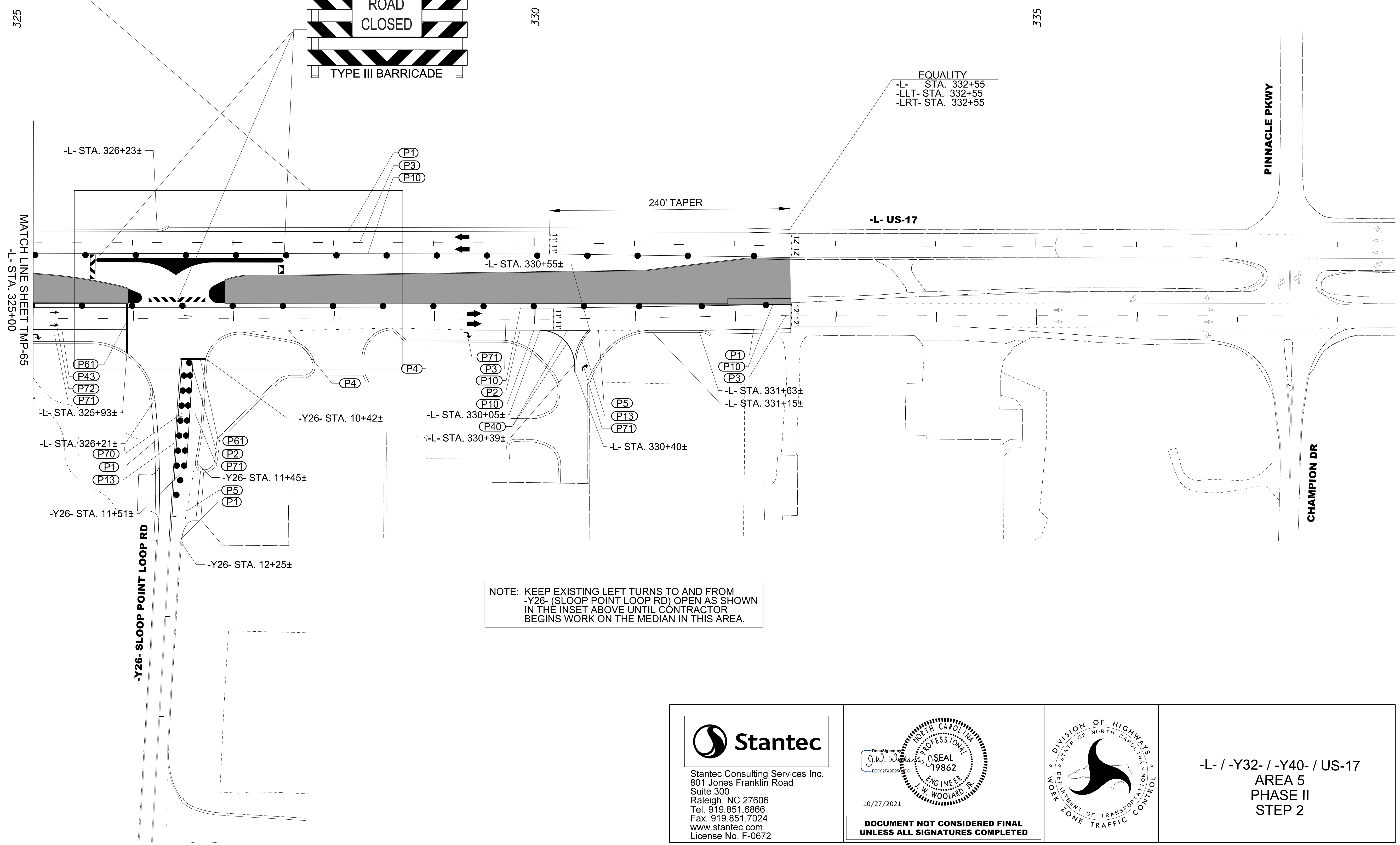
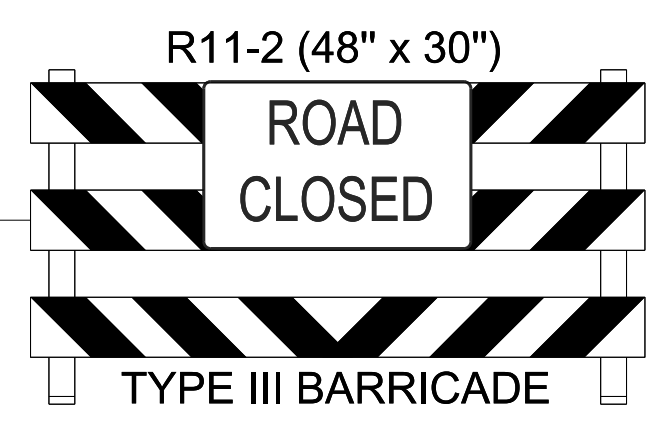

NOTE: KEEP EXISTING LEFT TURNS TO AND FROM -Y26- (SLOOP POINT LOOP RD) OPEN AS SHOWN IN THE INSET ABOVE UNTIL CONTRACTOR BEGINS WORK ON THE MEDIAN IN THIS AREA.

9/13/2021
U:\Traffic\Transportation Management\Plan\TCP\PLAN SHEETS\IR-3300B\TMP_66\AREA 5_PHASE 2_STEP 2.dgn
angood

Stantec Consulting Services Inc.
801 Jones Franklin Road
Suite 300
Raleigh, NC 27606
Tel. 919.851.6866
Fax. 919.851.7024
www.stantec.com
License No. F-0672

10/27/2021

DIVISION OF HIGHWAYS
STATE OF NORTH CAROLINA
DEPARTMENT OF TRANSPORTATION
WORK ZONE TRAFFIC CONTROL

-L- / -Y32- / -Y40- / US-17
AREA 5
PHASE II
STEP 2

DOCUMENT NOT CONSIDERED FINAL
UNLESS ALL SIGNATURES COMPLETED

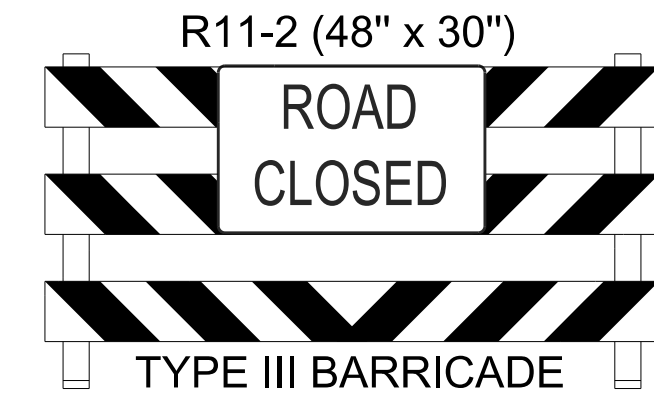
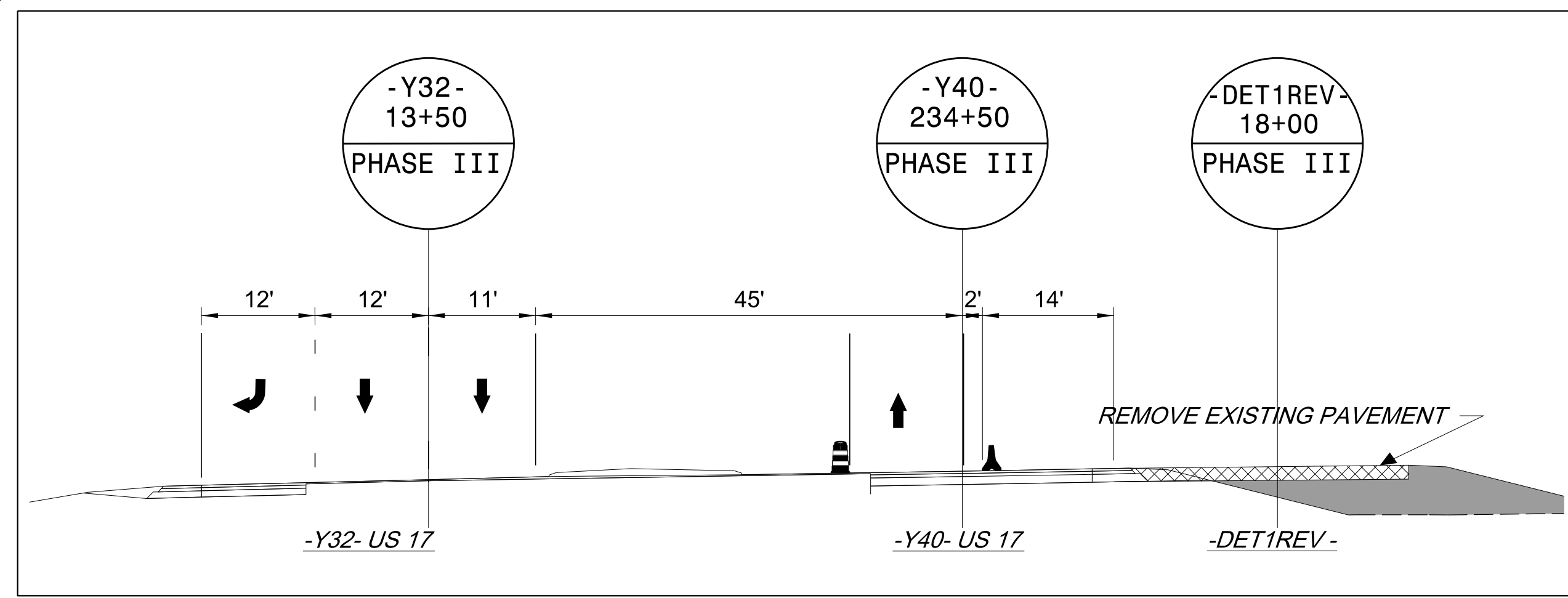
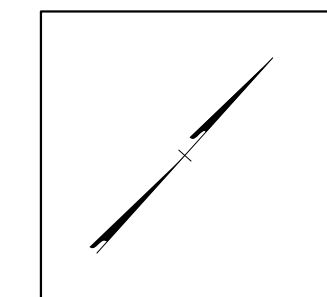

EQUALITY
 -L- STA. 231+00
 -Y32- STA. 10+00
 -Y40- STA. 231+00

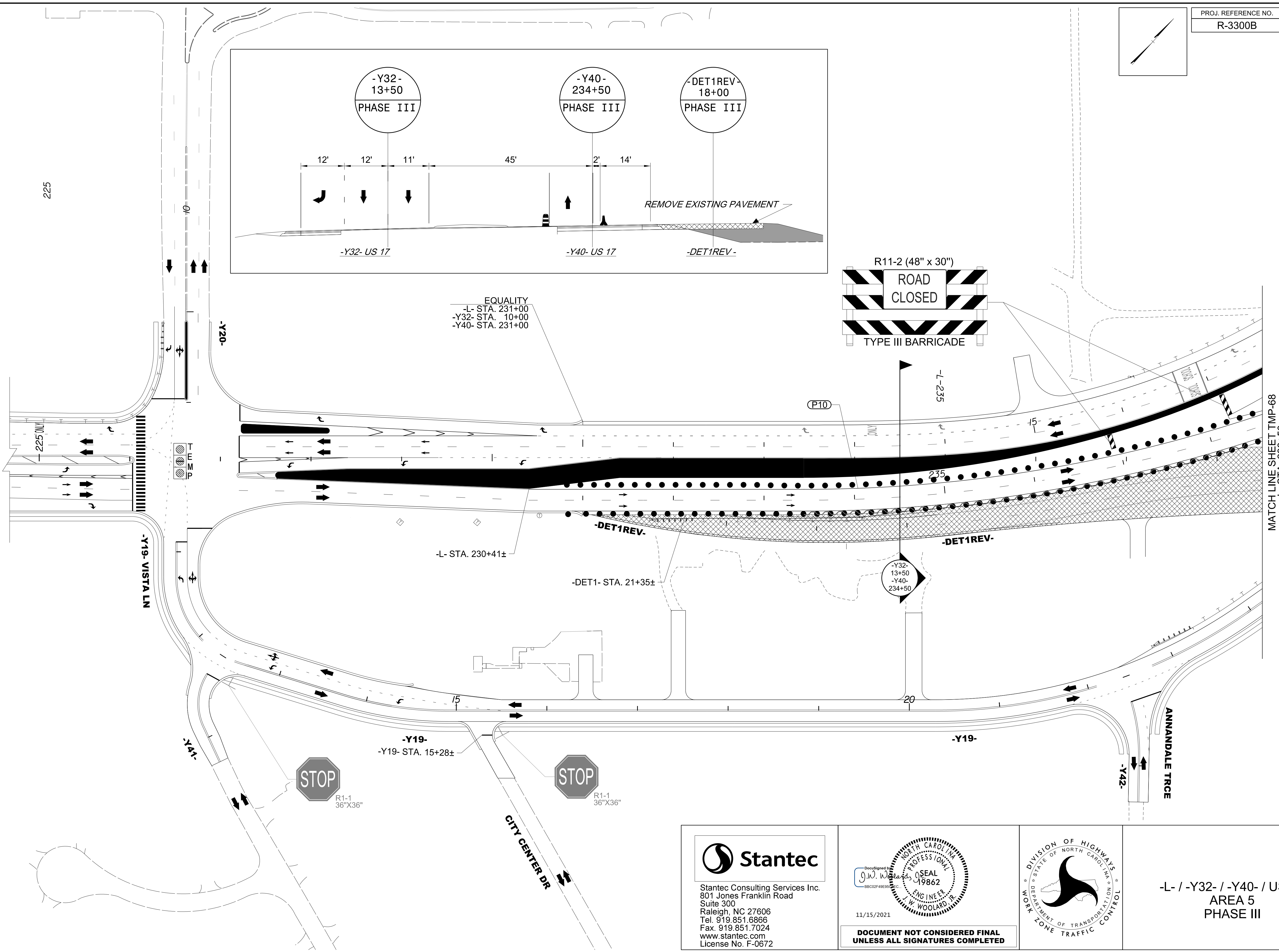

11/15/2021
 U:\Traffic\Transportation Management\Plan\TCP\PLAN SHEETS\IR-3300B\TMP_67_AREA 5_PHASE 3.dgn
 angood

Stantec
 Stantec Consulting Services Inc.
 801 Jones Franklin Road
 Suite 300
 Raleigh, NC 27606
 Tel. 919.851.6866
 Fax. 919.851.7024
 www.stantec.com
 License No. F-0672

DocuSigned by:
 J.W. Woolard
 BB02F48E90
 11/15/2021

**DOCUMENT NOT CONSIDERED FINAL
 UNLESS ALL SIGNATURES COMPLETED**

-L- / -Y32- / -Y40- / US-17
 AREA 5
 PHASE III

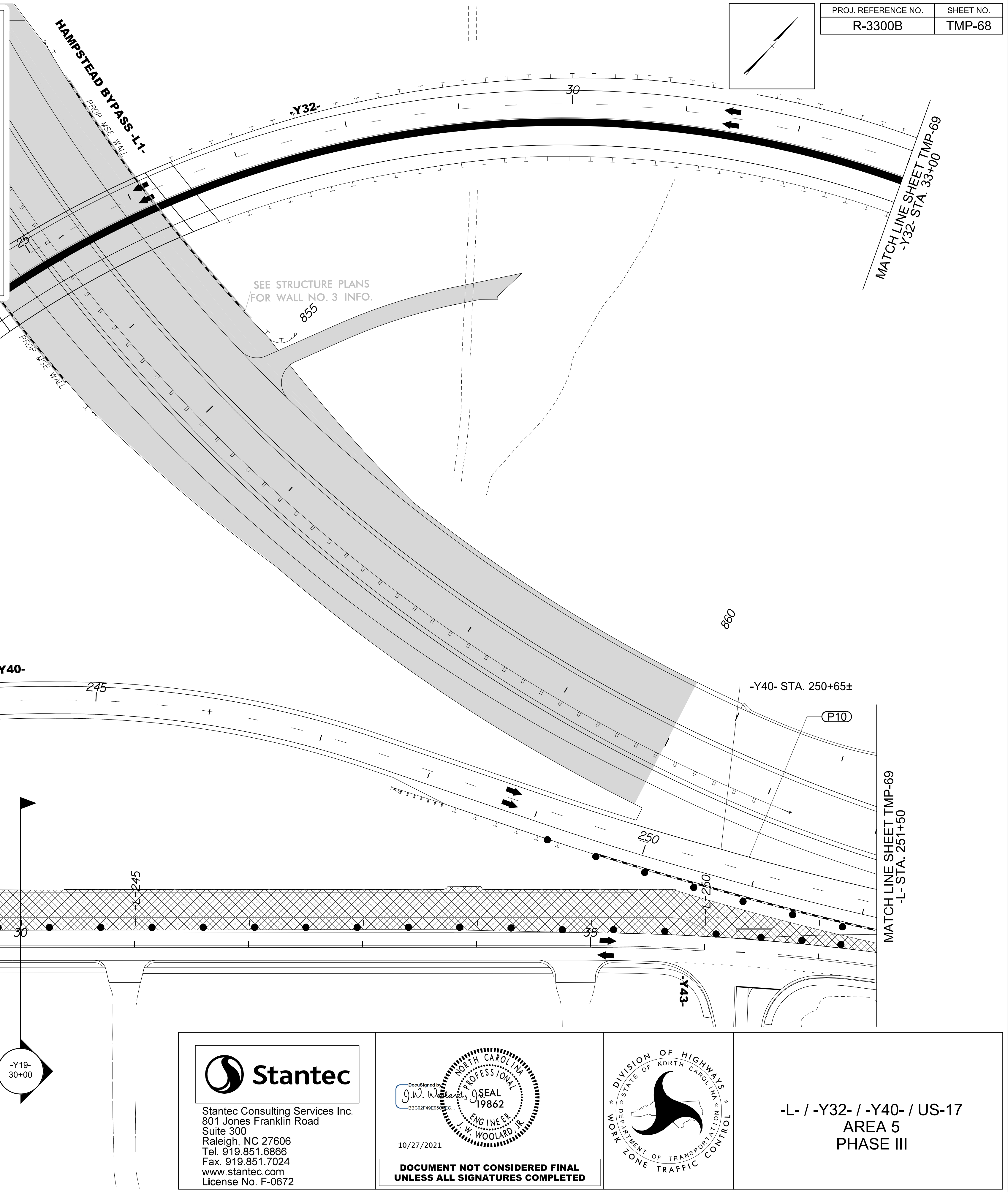
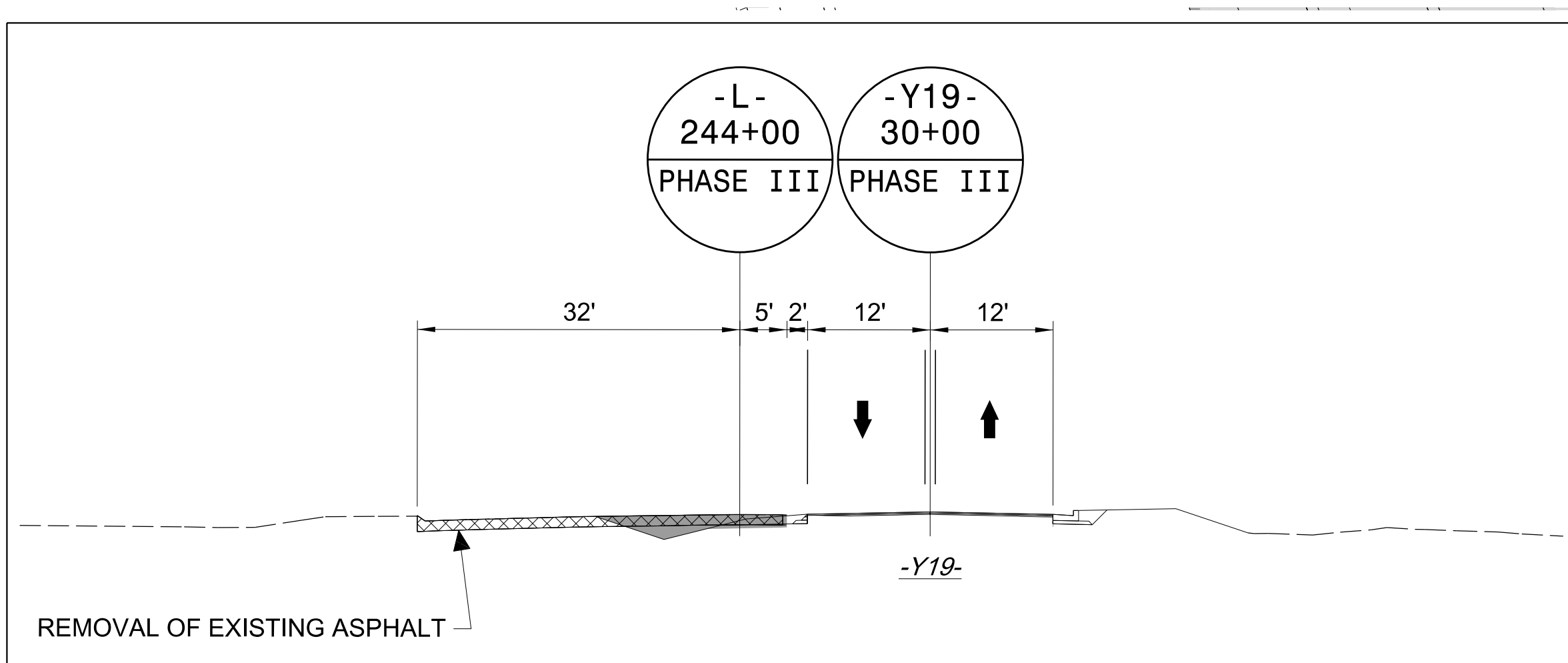

9/24/2021
L:\Traffic\Transportation Management Plan\TCP\PLAN SHEETS\R-3300B_TMP_68_AREA 5_PHASE 3.dgn
angood

 **Stantec**
Stantec Consulting Services Inc.
801 Jones Franklin Road
Suite 300
Raleigh, NC 27606
Tel. 919.851.6866
Fax. 919.851.7024
www.stantec.com
License No. F-0672

DocuSigned by:

10/27/2021
**DOCUMENT NOT CONSIDERED FINAL
UNLESS ALL SIGNATURES COMPLETED**

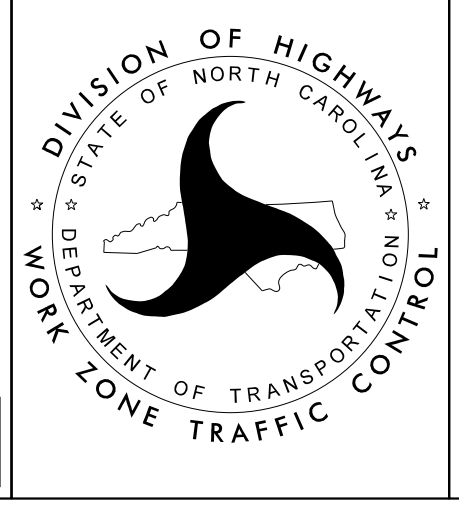

**-L- / -Y32- / -Y40- / US-17
AREA 5
PHASE III**

PROJ. REFERENCE NO.	SHEET NO.
R-3300B	TMP-69

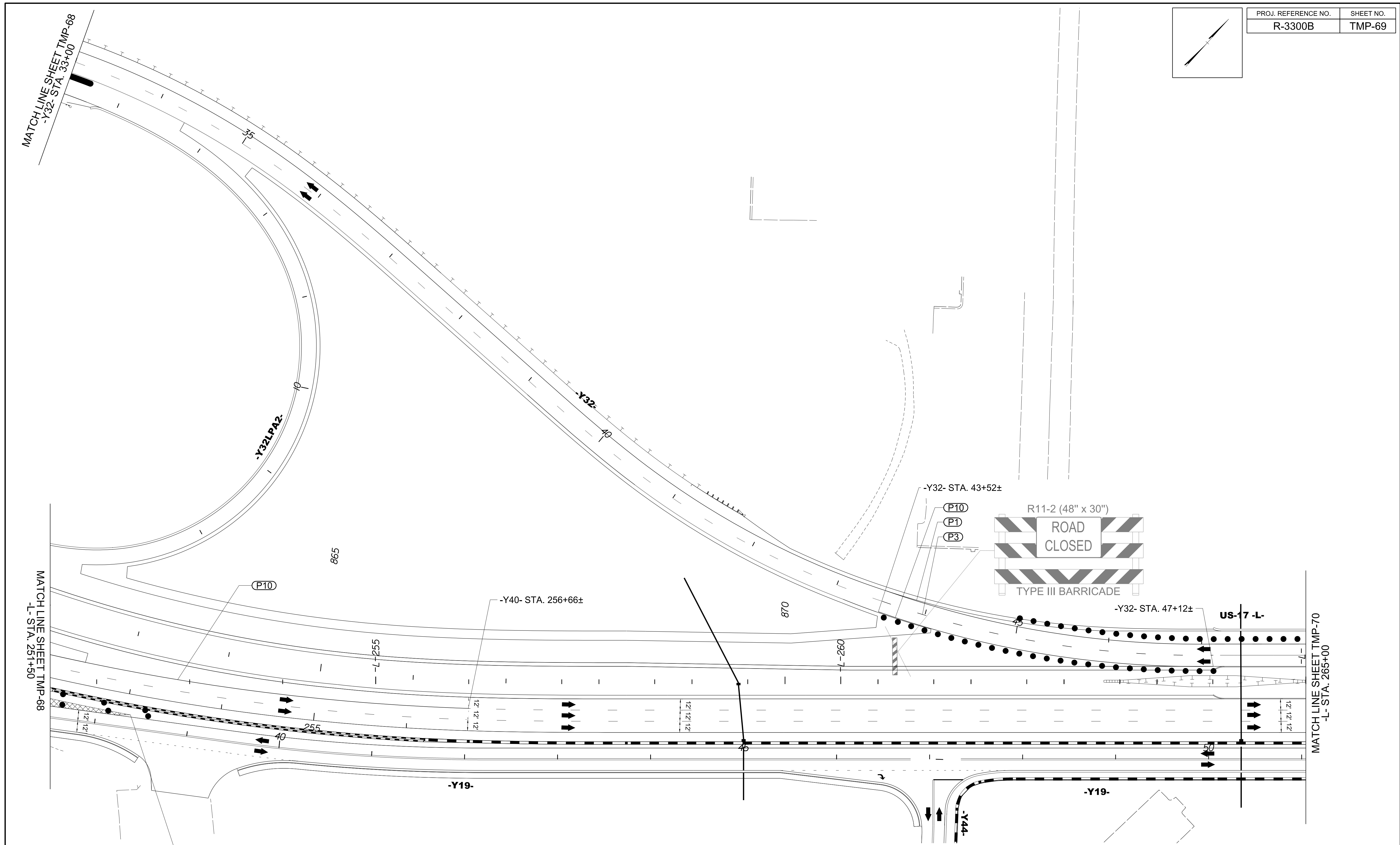
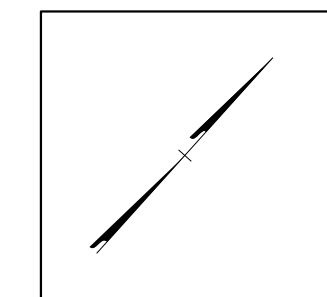

9/13/2021
 U:\Traffic\Transportation Management Plan\TCP\PLAN SHEETS\VR-3300B_TMP_69_AREA 5_PHASE 3.dgn
 angood

Stantec Consulting Services Inc.
 801 Jones Franklin Road
 Suite 300
 Raleigh, NC 27606
 Tel. 919.851.6866
 Fax. 919.851.7024
 www.stantec.com
 License No. F-0672

10/27/2021
**DOCUMENT NOT CONSIDERED FINAL
 UNLESS ALL SIGNATURES COMPLETED**

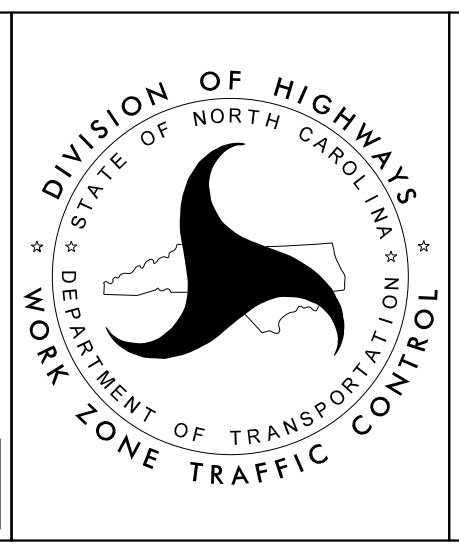

DIVISION OF HIGHWAYS
 NORTH CAROLINA
 DEPARTMENT OF TRANSPORTATION
 WORK ZONE TRAFFIC CONTROL

-L- / -Y32- / -Y40- / US-17
 AREA 5
 PHASE III

PROJ. REFERENCE NO.	SHEET NO.
R-3300B	TMP-70

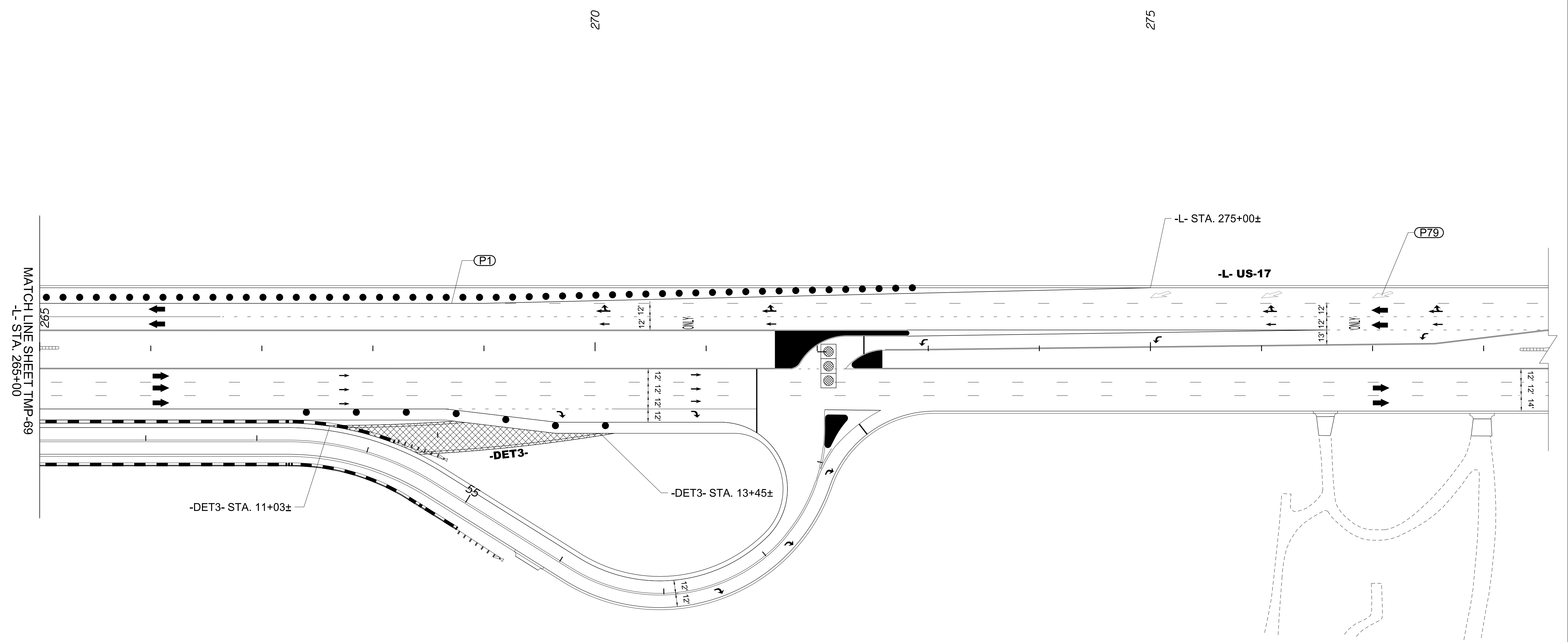
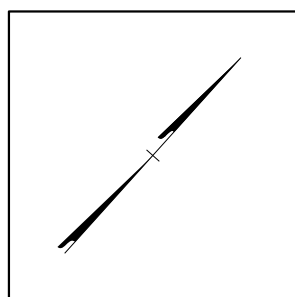

9/13/2021
 U:\Traffic\Transportation Management\Plan\TCP\PLAN SHEETS\IR-3300B\TMP_70_AREA 5_PHASE 3.dgn
 angood

Stantec Consulting Services Inc.
 801 Jones Franklin Road
 Suite 300
 Raleigh, NC 27606
 Tel. 919.851.6866
 Fax. 919.851.7024
 www.stantec.com
 License No. F-0672

Documented by
 J.W. Williams
 PROFESSIONAL SEAL
 19862
 ENGINEER
 W. W. WOOLARD, R.
 10/27/2021

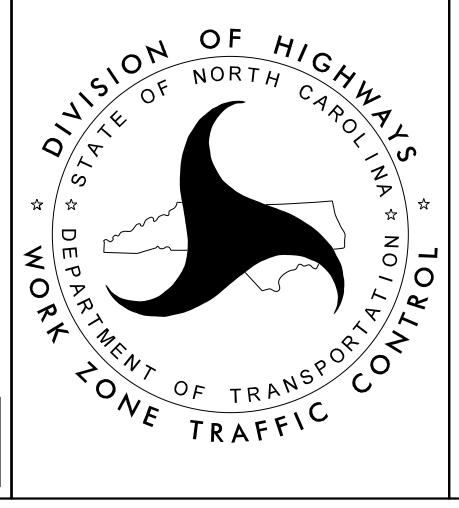

-L- / -Y32- / -Y40- / US-17
 AREA 5
 PHASE III

DOCUMENT NOT CONSIDERED FINAL UNLESS ALL SIGNATURES COMPLETED