

03/24/20

TIP PROJECT: BR-0035

T.I.P. NO.	SHEET NO.
BR-0035	UC-1

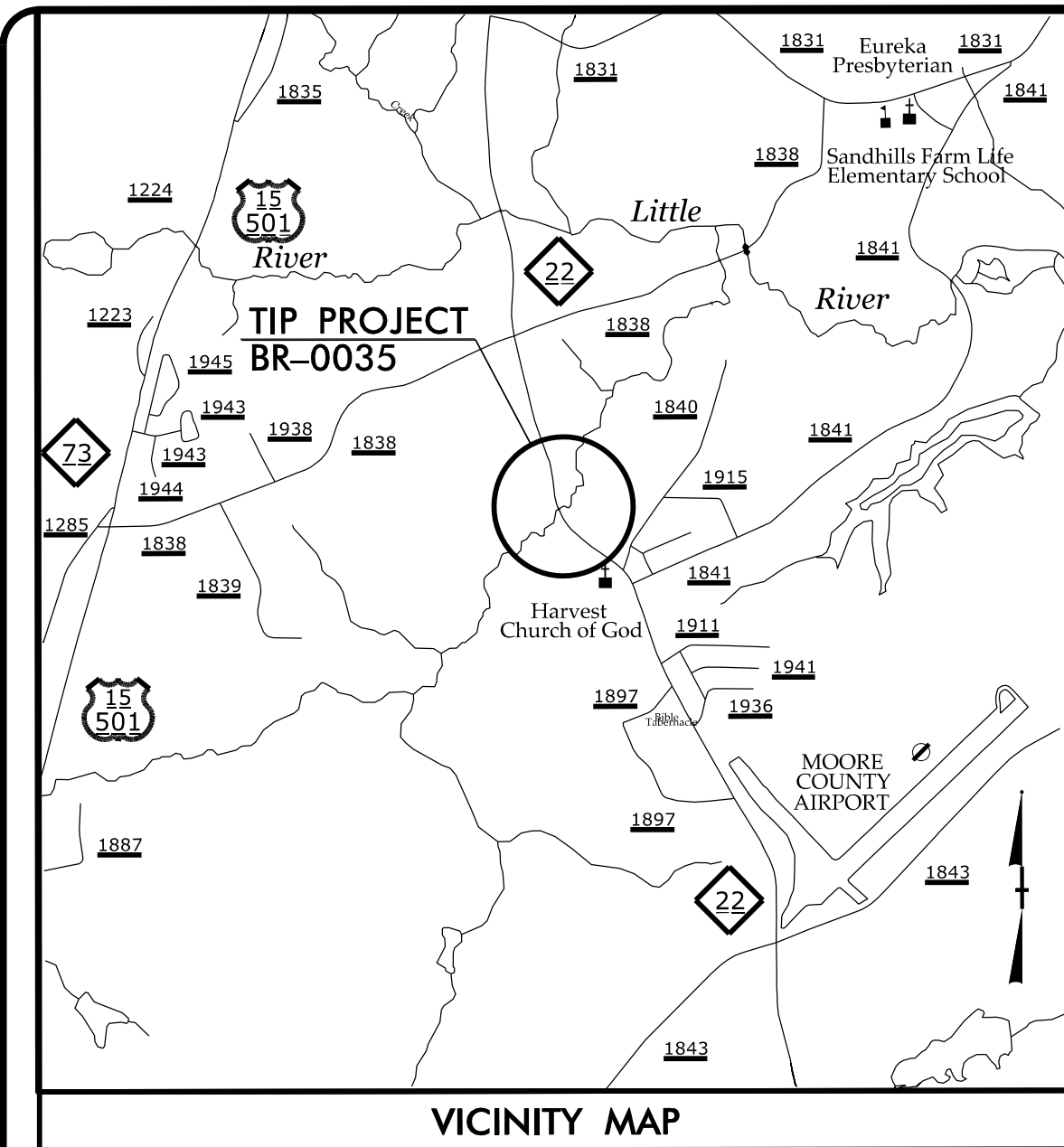

STATE OF NORTH CAROLINA DIVISION OF HIGHWAYS

UTILITY CONSTRUCTION PLANS MOORE COUNTY

LOCATION: NC 22 BRIDGE OVER NICK'S CREEK

TYPE OF WORK: WATER LINE RELOCATION
RELOCATION

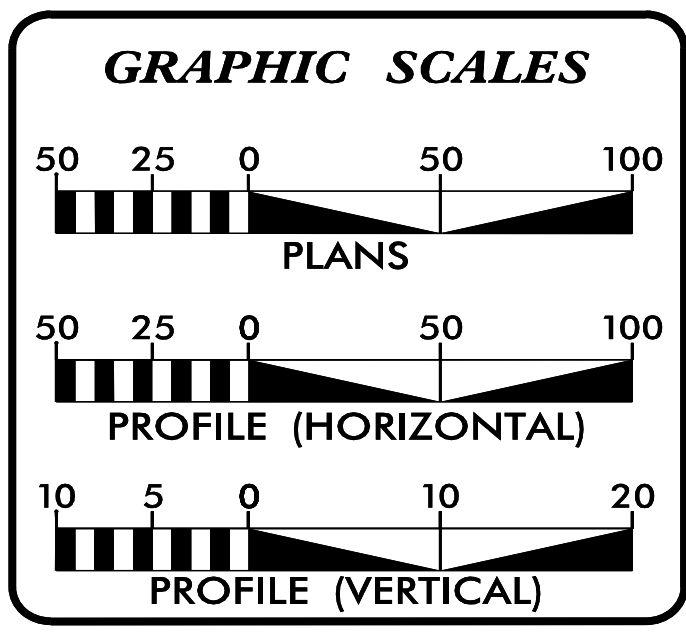
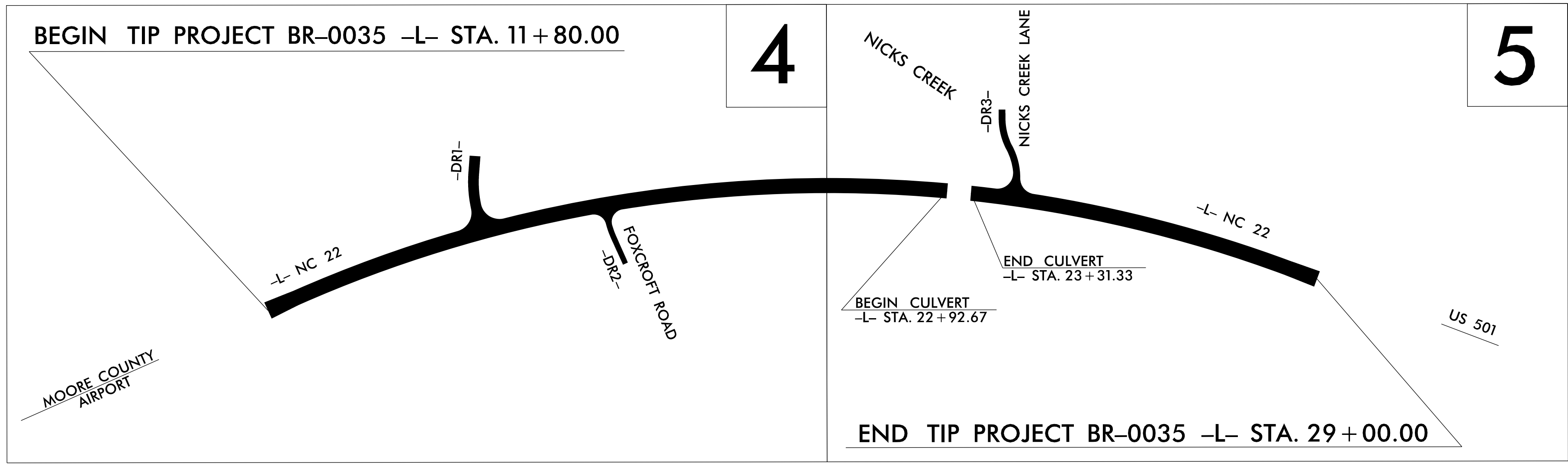
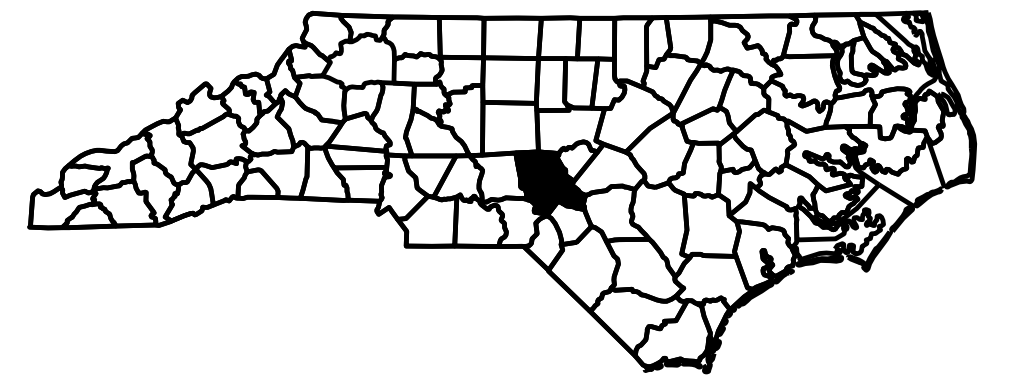

INDEX OF SHEETS

SHEET NO.:	DESCRIPTION:
UC-1	TITLE SHEET
UC-2	UTILITY SYMBOLOGY
UC-3	NOTES
UC-3B THRU UC-3C	DETAILS
UC-4	PLAN SHEETS
UC-5	PROFILE SHEETS

WATER OWNERS ON PROJECT

WATER: TOWN OF SOUTHERN PINES
Water Dept.: 910-692-1983
Emergency/After hours: 910-692-1627

PREPARED IN THE OFFICE OF

CONSULTANT INFO
MCGILL ASSOCIATES, P.A.
5 REGIONAL CIRCLE, SUITE A
PINEHURST, NC 28374
910-295-3159

DAVID HONEYCUTT CONSULTANT CONTACT #1
MATTHEW JONES CONSULTANT CONTACT #2

SEAL

10/14/2021

PRELIMINARY PLANS
DO NOT USE FOR CONSTRUCTION

DOCUMENT NOT CONSIDERED FINAL
UNTIL ALL SIGNATURES ARE COMPLETED

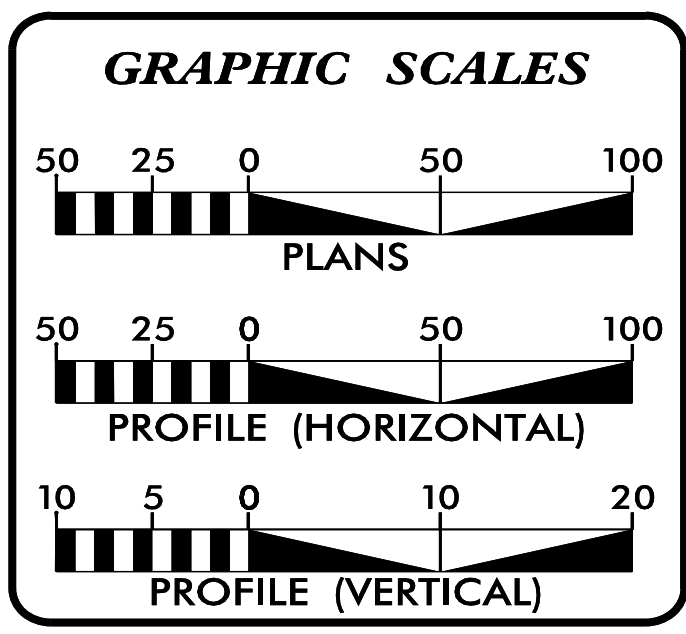

INDEX OF SHEETS

SHEET NO.:	DESCRIPTION:
UC-3A	NOTES
UC-3D THRU UC-3G	DETAILS
UC-6 THRU UC-7	PLAN SHEETS
UC-8	PROFILE SHEETS

WATER AND SEWER OWNERS ON PROJECT

WATER AND SEWER: TOWN OF CARTHAGE
Water Dept.: 910-947-5041
Public Works: 910-947-5041
Emergency/After hours: 910-783-5723

PREPARED IN THE OFFICE OF

CONSULTANT INFO
LKC ENGINEERING
140 AQUA SHED COURT
ABERDEEN, NC 28315
910-420-1437

MARK LACY CONSULTANT CONTACT #1
XXXX CONSULTANT CONTACT #2

SEAL

10/14/2021

DIVISION OF HIGHWAYS UTILITIES UNIT
1555 MAIL SERVICES CENTER
RALEIGH, NC 27699-1555
PHONE (919) 707-6690
FAX (919) 250-4151

ALI KOUCHEKI, P.E. UTILITIES REGIONAL ENGINEER
JON LOUGHRY UTILITIES ENGINEER
DAYTON MARTIN, III UTILITIES AREA COORDINATOR
XXXX UTILITIES COORDINATOR

\$\$\$\$\$ SYSTEM \$\$\$\$\$\$
\$\$\$\$\$ USERNAME \$\$\$\$\$\$

STATE OF NORTH CAROLINA
DIVISION OF HIGHWAYS

UTILITIES PLAN SHEET SYMBOLS

PROPOSED WATER SYMBOLS

Water Line (Sized as Shown)	
11 1/4 Degree Bend	
22 1/2 Degree Bend	
45 Degree Bend	
90 Degree Bend	
Plug	
Tee	
Cross	
Reducer	
Gate Valve	
Butterfly Valve	
Tapping Valve	
Line Stop	
Line Stop with Bypass	
Blow Off	
Fire Hydrant	
Relocate Fire Hydrant	
Remove Fire Hydrant	
Water Meter	
Relocate Water Meter	
Remove Water Meter	
Water Pump Station	
RPZ Backflow Preventer	
DCV Backflow Preventer	
Relocate RPZ Backflow Preventer	
Relocate DCV Backflow Preventer	

PROPOSED SEWER SYMBOLS

Gravity Sewer Line (Sized as Shown)	
Force Main Sewer Line (Sized as Shown)	
Manhole (Sized per Note)	
Sewer Pump Station	

PROPOSED MISCELLANEOUS UTILITIES SYMBOLS

Power Pole	
Telephone Pole	
Joint Use Pole	
Telephone Pedestal	
Utility Line by Others (Type as Shown)	
Trenchless Installation	
Encasement by Open Cut	
Encasement	

Thrust Block	
Air Release Valve	
Utility Vault	
Concrete Pier	
Steel Pier	
Plan Note	
Pay Item Note	

EXISTING UTILITIES SYMBOLS

Power Pole	
Telephone Pole	
Joint Use Pole	
Utility Pole	
Utility Pole with Base	
H-Frame Pole	
Power Transmission Line Tower	
Water Manhole	
Power Manhole	
Telephone Manhole	
Sanitary Sewer Manhole	
Hand Hole for Cable	
Power Transformer	
Telephone Pedestal	
CATV Pedestal	
Gas Valve	
Gas Meter	
Located Miscellaneous Utility Object	
Abandoned According to Utility Records	
End of Information	

*Underground Power Line	
*Underground Telephone Cable	
*Underground Telephone Conduit	
*Underground Fiber Optics Telephone Cable	
*Underground TV Cable	
*Underground Fiber Optics TV Cable	
*Underground Gas Pipeline	
Aboveground Gas Pipeline	
*Underground Water Line	
Aboveground Water Line	
*Underground Gravity Sanitary Sewer Line	
Aboveground Gravity Sanitary Sewer Line	
*Underground SS Forced Main Line	
Underground Unknown Utility Line	
SUE Test Hole	
Water Meter	
Water Valve	
Fire Hydrant	
Sanitary Sewer Cleanout	

*For Existing Utilities
 Utility Line Drawn from Record (Type as Shown)
 Designated Utility Line (Type as Shown)

3/13/20

11
12
13
14
15
16
17
18
19
20
21
22
23
24
25
26
27
28
29
30
31
32
33
34
35
36
37
38
39
40
41
42
43
44
45
46
47
48
49
50
51
52
53
54
55
56
57
58
59
60
61
62
63
64
65
66
67
68
69
70
71
72
73
74
75
76
77
78
79
80
81
82
83
84
85
86
87
88
89
90
91
92
93
94
95
96
97
98
99
100



PROJECT REFERENCE NO.	SHEET NO.
BR-0035	UC-3
DESIGNED BY: MRJ	
DRAWN BY: ALH	
CHECKED BY: MRJ	
APPROVED BY: DLH	
REVISED:	
NORTH CAROLINA DEPARTMENT OF TRANSPORTATION	
UTILITIES ENGINEERING SEC. PHONE: (919) 707-6690 FAX: (919) 250-4151	
UTILITY CONSTRUCTION PLANS ONLY	

UTILITY CONSTRUCTION

GENERAL NOTES:

1. THE PROPOSED UTILITY CONSTRUCTION SHALL MEET THE APPLICABLE REQUIREMENTS OF THE NC DEPARTMENT OF TRANSPORTATION'S "STANDARD SPECIFICATIONS FOR ROADS AND STRUCTURES" DATED JANUARY 2018.
2. THE EXISTING UTILITIES BELONG TO THE TOWN OF SOUTHERN PINES.
3. ALL WATER LINES TO BE INSTALLED WITHIN COMPLIANCE OF THE RULES AND REGULATIONS OF THE NORTH CAROLINA DEPARTMENT OF ENVIRONMENTAL QUALITY, DIVISION OF WATER RESOURCES, PUBLIC WATER SUPPLY SECTION. PERFORM ALL WORK IN ACCORDANCE WITH THE APPLICABLE PLUMBING CODES.
4. THE UTILITY OWNER OWNS THE EXISTING UTILITY FACILITIES AND WILL OWN THE NEW UTILITY FACILITIES AFTER ACCEPTANCE BY THE DEPARTMENT. THE DEPARTMENT OWNS THE CONSTRUCTION CONTRACT AND HAS ADMINISTRATIVE AUTHORITY. COMMUNICATIONS AND DECISIONS BETWEEN THE CONTRACTOR AND UTILITY OWNER ARE NOT BINDING UPON THE DEPARTMENT OR THIS CONTRACT UNLESS AUTHORIZED BY THE ENGINEER. AGREEMENTS BETWEEN THE UTILITY OWNER AND CONTRACTOR FOR THE WORK THAT IS NOT PART OF THIS CONTRACT OR IS SECONDARY TO THIS CONTRACT ARE ALLOWED, BUT ARE NOT BINDING UPON THE DEPARTMENT.
5. PROVIDE ACCESS FOR THE DEPARTMENT PERSONNEL AND THE OWNER'S REPRESENTATIVES TO ALL PHASES OF CONSTRUCTION. NOTIFY DEPARTMENT PERSONNEL AND THE UTILITY OWNER TWO WEEKS PRIOR TO COMMENCEMENT OF ANY WORK AND ONE WEEK PRIOR TO SERVICE INTERRUPTION. KEEP UTILITY OWNERS' REPRESENTATIVES INFORMED OF WORK PROGRESS AND PROVIDE OPPORTUNITY FOR INSPECTION OF CONSTRUCTION AND TESTING.

6. THE PLANS DEPICT THE BEST AVAILABLE INFORMATION FOR THE LOCATION, SIZE, AND TYPE OF MATERIAL FOR ALL EXISTING UTILITIES. MAKE INVESTIGATIONS FOR DETERMINING THE EXACT LOCATION, SIZE, AND TYPE MATERIAL OF THE EXISTING FACILITIES AS NECESSARY FOR THE CONSTRUCTION OF THE PROPOSED UTILITIES AND FOR AVOIDING DAMAGE TO EXISTING FACILITIES. REPAIR ANY DAMAGE INCURRED TO EXISTING FACILITIES TO THE ORIGINAL OR BETTER CONDITION AT NO ADDITIONAL COST TO THE DEPARTMENT.
7. MAKE FINAL CONNECTIONS OF THE NEW WORK TO THE EXISTING SYSTEM WHERE INDICATED ON THE PLANS, AS REQUIRED TO FIT THE ACTUAL CONDITIONS, OR AS DIRECTED.
8. MAKE CONNECTIONS BETWEEN EXISTING AND PROPOSED UTILITIES AT TIMES MOST CONVENIENT TO THE PUBLIC, WITHOUT ENDANGERING THE UTILITY SERVICE, AND IN ACCORDANCE WITH THE UTILITY OWNER'S REQUIREMENTS. MAKE CONNECTIONS ON WEEKENDS, AT NIGHT, AND ON HOLIDAYS IF NECESSARY.
9. ALL UTILITY MATERIALS SHALL BE APPROVED PRIOR TO DELIVERY TO THE PROJECT. SEE 1500-7, " SUBMITTALS AND RECORDS" IN SECTION 1500 OF THE STANDARD SPECIFICATIONS.
10. THE CONTRACTOR SHALL PROVIDE AS-BUILT DRAWINGS INDICATING THE ACTUAL AS-BUILT CONDITION OF THE PROJECT AT COMPLETION. AS-BUILTS WILL BE FURNISHED AT OR PRIOR TO FINAL INSPECTION BY THE ENGINEER. AS-BUILTS WILL BE REVIEWED BY THE ENGINEERS REPRESENTATIVE PRIOR TO APPROVAL OF MONTHLY PROGRESS PAYMENTS. MARK-UP COPIES OF THE DRAWINGS INDICATING ALL DIMENSIONS AND ELEVATIONS ARE ACCEPTABLE AS AS-BUILT DRAWINGS.

PROJECT SPECIFIC NOTES:

1. PROPOSED WATER LINE WL-1 FROM STATION 10+00.00 TO STATION 13+39.29 SHALL BE D.I.R.J. (DUCTILE IRON RESTRAINED JOINT) PIPE.
2. NITRILE GASKETS SHALL BE USED IF PETROLEUM CONTAMINATED SOILS ARE ENCOUNTERED DURING CONSTRUCTION.
3. ALL WATER LINE FITTINGS SHALL BE PRESSURE CLASS 350 DUCTILE IRON RESTRAINED JOINT IN ACCORDANCE WITH ANSI A21.10 / AWWA C110 AND ANSI A21.4 / AWWA C104.
4. CONTRACTOR'S ATTENTION IS DIRECTED TO SECTIONS 102, 107, AND 1550 OF THE STANDARD SPECIFICATIONS CONCERNING TRENCHLESS INSTALLATION. IT IS CONTRACTOR'S RESPONSIBILITY TO HAVE BORE DESIGNED AND SEALED BY A LICENSED NORTH CAROLINA PROFESSIONAL ENGINEER. NO DAMAGE IS ALLOWED TO RIVER, WETLANDS, OR BUFFER ZONES.

UTILITY CONSTRUCTION

TOWN OF CARTHAGE UTILITY CONSTRUCTION NOTES

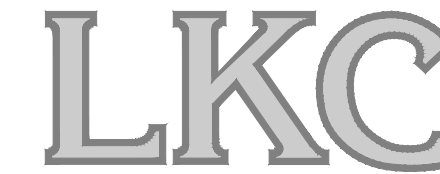

Engineering
Landscape Architecture
Surveying

LKC Engineering, PLLC
140 Aqua Shed Court
Aberdeen, NC 28315
O: 910.420.1437
F: 910.637.0096
lkceengineering.com
License No. P-1095

PROJECT REFERENCE NO. BR-0035	SHEET NO. UC-3A
DESIGNED BY: MAL	
DRAWN BY: BCS	
CHECKED BY: MAL	
APPROVED BY: -	
REVISED: -	
NORTH CAROLINA DEPARTMENT OF TRANSPORTATION	10/12/2021
UTILITIES ENGINEERING SEC. PHONE: (919) 707-6690 FAX: (919) 250-4151	UTILITY CONSTRUCTION PLANS ONLY
UTILITY CONSTRUCTION	
DOCUMENT NOT CONSIDERED FINAL UNLESS ALL SIGNATURES COMPLETED	

CONSTRUCTION NOTES:

1. THE CONTRACTOR SHALL CONTACT THE POWER CO., GAS CO., AND TELEPHONE CO. FOR THE EXACT LOCATION OF ALL UNDERGROUND MAINS, CABLES, OR LINES BEFORE CONSTRUCTION BEGINS.
2. PIPE SEPARATION: THE FOLLOWING MINIMUM PIPE SEPARATION WILL BE MAINTAINED: 18 INCHES VERTICAL SEPARATION BETWEEN CROSSING OF SANITARY SEWER AND STORM SEWERS, 18 INCHES VERTICAL SEPARATION BETWEEN CROSSING OF SEWER (INCLUDING FORCE MAINS) AND WATER MAINS, OR 10 FEET HORIZONTAL SEPARATION BETWEEN SANITARY SEWER (INCLUDING FORCE MAINS) AND WATER MAINS. IF THESE SEPARATIONS CANNOT BE MAINTAINED, DUCTILE IRON PIPE WILL BE USED 10 FEET EITHER SIDE OF CROSSING AND ALONG ENTIRE LENGTH OF LINE LESS THAN 10 HORIZONTAL FEET FROM WATER MAINS. THE CONTRACTOR SHALL RECEIVE APPROVAL FROM THE ENGINEER IN THE FIELD BEFORE PAYMENT WILL BE MADE AT DUCTILE IRON PRICES.
3. THE CONTRACTOR SHALL BE RESPONSIBLE FOR LOCATING AND PROTECTING ALL EXISTING WATER SERVICE CONNECTIONS DURING CONSTRUCTION. ANY DAMAGE WHICH OCCURS AS A RESULT OF THE CONSTRUCTION SHALL BE REPAIRED AT NO ADDITIONAL COST TO THE OWNER. IN THE EVENT OF A TEMPORARY SERVICE INTERRUPTION, THE CONTRACTOR SHALL IMMEDIATELY NOTIFY THE OWNER AND BEGIN REPAIRS.
4. ALL PIPING FOR PRESSURE MAINS SHALL BE PRESSURE TESTED, GRAVITY LINES SHALL BE AIR TESTED, AND MANHOLES SHALL BE VACUUM TESTED, ALL IN ACCORDANCE WITH THE DETAILED SPECIFICATIONS AND SPECIAL PROVISIONS. THE CONTRACTOR SHALL NOTIFY THE ENGINEER 24 HOURS IN ADVANCE OF ALL SCHEDULED TESTING.
5. ALL WORK PERFORMED WITHIN NORTH CAROLINA DEPARTMENT OF TRANSPORTATION RIGHTS-OF-WAY SHALL BE PERFORMED IN STRICT ACCORDANCE WITH THE NCDOT CONSTRUCTION AND MAINTENANCE OPERATIONS SUPPLEMENT TO THE MANUAL OR UNIFORM TRAFFIC CONTROL DEVICES. THE CONTRACTOR SHALL BE RESPONSIBLE FOR PERFORMING THE WORK AND ADHERING TO THE RIGHT-OF-WAY ENCROACHMENT CONTRACT SPECIAL PROVISIONS.
6. THE CONTRACTOR SHALL BE RESPONSIBLE FOR CONTACTING THE OWNER TO ACCURATELY DETERMINE THE LOCATION OF EXISTING WATER MAINS AND SEWER LINES WITHIN THE PROJECT AREA. THE CONTRACTOR SHALL TAKE ADDITIONAL CAUTION IN EXCAVATING AROUND THE SERVICE LINES AND MAINS WHILE WORKING WITHIN THIS PROJECT. ANY DAMAGE TO THE MAINS OR SERVICE LINES SHALL BE THE RESPONSIBILITY OF THE CONTRACTOR.
7. THE CONTRACTOR SHALL REMOVE AND REPLACE EXISTING CULVERTS AND DRAINAGE STRUCTURES AS NECESSARY DURING THE CONSTRUCTION OF THE SEWER LINES. ANY DAMAGE TO THE CULVERTS SHALL BE REPLACED BY THE CONTRACTOR AT NO ADDITIONAL COST TO THE OWNER. SPECIAL CIRCUMSTANCES (I.E. UNREINFORCED CONCRETE PIPE) SHALL BE BROUGHT TO THE ATTENTION OF THE ENGINEER IMMEDIATELY IN ORDER TO RECEIVE ANY NECESSARY
8. THE CONTRACTOR IS INSTRUCTED TO CONTROL SEDIMENTATION RUNOFF BY METHODS APPROVED BY THE ENGINEERS DURING THE COURSE OF CONSTRUCTION OF THIS PROJECT. THE CONTRACTOR IS REMINDED THAT ALL WORK SHALL MEET ALL APPLICABLE REQUIREMENTS OF THE RULES AND REGULATIONS OF EROSION AND SEDIMENT CONTROL AS PUBLISHED BY THE DEPARTMENT OF NC ENVIRONMENTAL QUALITY.
9. THE CONTRACTOR SHALL PROVIDE AS-BUILT DRAWINGS INDICATING THE ACTUAL AS-BUILT CONDITION OF THE PROJECT AT COMPLETION. AS-BUILTS WILL BE FURNISHED AT OR PRIOR TO FINAL INSPECTION BY THE ENGINEER. AS-BUILTS WILL BE REVIEWED BY THE ENGINEERS REPRESENTATIVE PRIOR TO APPROVAL OF MONTHLY PROGRESS PAYMENTS. MARK-UP COPIES OF THE DRAWINGS INDICATING ALL DIMENSIONS AND ELEVATIONS ARE ACCEPTABLE AS AS-BUILT DRAWINGS.

GENERAL NOTES:

1. THE PROPOSED UTILITY CONSTRUCTION SHALL MEET THE APPLICABLE REQUIREMENTS OF THE NC DEPARTMENT OF TRANSPORTATION'S STANDARD SPECIFICATIONS FOR ROADS AND STRUCTURES DATED JANUARY 2018.
2. THE EXISTING UTILITIES BELONG TO TOWN OF CARTHAGE.
3. ALL WATER LINES TO BE INSTALLED WITHIN COMPLIANCE OF THE RULES AND REGULATIONS OF THE NORTH CAROLINA DEPARTMENT OF ENVIRONMENTAL QUALITY, DIVISION OF WATER RESOURCES, PUBLIC WATER SUPPLY SECTION. ALL SEWER LINES TO BE INSTALLED WITHIN COMPLIANCE OF THE RULES AND REGULATIONS OF THE NORTH CAROLINA DEPARTMENT OF ENVIRONMENTAL QUALITY, DIVISION OF WATER RESOURCES, WATER QUALITY SECTION. PERFORM ALL WORK IN ACCORDANCE WITH THE APPLICABLE PLUMBING CODES.
4. THE UTILITY OWNER OWNS EXISTING UTILITY FACILITIES AND WILL OWN THE NEW UTILITY FACILITIES AFTER ACCEPTANCE BY THE DEPARTMENT. THE DEPARTMENT OWNS THE CONSTRUCTION CONTRACT AND HAS ADMINISTRATIVE AUTHORITY. COMMUNICATIONS AND DECISIONS BETWEEN THE CONTRACTOR AND UTILITY OWNER ARE NOT BINDING UPON THE DEPARTMENT OR THIS CONTRACT UNLESS AUTHORIZED BY THE BY THE ENGINEER. AGREEMENTS BETWEEN THE UTILITY OWNER AND CONTRACTOR FOR THE WORK THAT IS NOT PART OF THIS CONTRACT ARE ALLOWED, BUT ARE NOT BINDING UPON THE DEPARTMENT.
5. PROVIDE ACCESS FOR THE DEPARTMENT PERSONNEL AND THE OWNER'S REPRESENTATIVES TO ALL PHASES OF CONSTRUCTION, NOTIFY DEPARTMENT PERSONNEL AND THE UTILITY OWNER TWO WEEKS PRIOR TO COMMENCEMENT OF ANY WORK AND ONE WEEK PRIOR TO SERVICE INTERRUPTION. KEEP UTILITY OWNER'S REPRESENTATIVES INFORMED OF WORK PROGRESS AND PROVIDE OPPORTUNITY FOR INSPECTION OF CONSTRUCTION AND TESTING.
6. THE PLANS DEPICT THE BEST AVAILABLE INFORMATION FOR THE LOCATION, SIZE, AND TYPE OF MATERIAL FOR ALL EXISTING UTILITIES. MAKE INVESTIGATIONS FOR DETERMINING THE EXACT LOCATION, SIZE, AND TYPE MATERIAL OF THE EXISTING FACILITIES AS NECESSARY FOR THE CONSTRUCTION OF THE PROPOSED UTILITIES AND FOR AVOIDING DAMAGE TO EXISTING FACILITIES. REPAIR ANY DAMAGE INCURRED TO EXISTING FACILITIES TO THE ORIGINAL OR BETTER CONDITION AT NO ADDITIONAL COST TO THE DEPARTMENT.
7. MAKE FINAL CONNECTIONS OF THE NEW WORK TO THE EXISTING SYSTEM WHERE INDICATED ON THE PLANS, AS REQUIRED TO FIT THE ACTUAL CONDITIONS, OR AS DIRECTED.
8. MAKE CONNECTIONS BETWEEN EXISTING AND PROPOSED UTILITIES AT TIMES MOST CONVENIENT TO THE PUBLIC, WITHOUT ENDANGERING THE UTILITY SERVICE, AND IN ACCORDANCE WITH THE UTILITY OWNER'S REQUIREMENTS. MAKE CONNECTIONS ON WEEKENDS, AT NIGHT, AND ON HOLIDAYS IF NECESSARY.
9. ALL UTILITY MATERIAL SUBMITTALS AND RECORDS IN SECTION 1500 OF THE STANDARD SPECIFICATIONS.

PROJECT SPECIFIC NOTES:

1. ALL PROPOSED FORCE MAIN AND WATER LINE TO BE PVC C-900 DR18 UNLESS NOTED OTHERWISE ON PLANS. ALL DUCTILE IRON PIPE SHALL BE PC350. AND DUCTILE IRON FORCE MAIN SHALL HAVE AN EPOXY INTERIOR LINING.
2. WELL IN ADVANCE OF BEGINNING UTILITY WORK, SOFT DIGS SHALL BE PERFORMED BY CONTRACTOR TO VERIFY ACTUAL WATER LINE DEPTH AND MATERIAL AT PROPOSED TIE-IN LOCATIONS.
3. LAY PIPE STRAIGHT IN ALIGNMENT AND GRADIENT OR FOLLOW TRUE CURVES AS NEARLY AS POSSIBLE. DO NOT DEFLECT ANY JOINT MORE THAN THE MAXIMUM DEFLECTION RECOMMENDED BY THE MANUFACTURER.
4. LKC/ TOWN OF CARTHAGE AND NCDOT TO REVIEW/ APPROVE RELEVANT SUBMITTALS.
5. ANY SERVICE INTERRUPTIONS SHALL BE SCHEDULED FOR MINIMAL IMPACT TO CUSTOMERS AND APPROVED BY TOWN OF CARTHAGE.
6. THE CONTRACTOR SHALL NOTIFY LKC/ TOWN OF CARTHAGE IN ADVANCE OF THE FOLLOWING ACTIVITIES:
 - A. START OF UTILITY CONSTRUCTION- 48 HOURS
 - B. MAIN LINE SERVICE INTERRUPTIONS- 96 HOURS
 - C. PRESSURE TESTING- 24 HOURS
 - D. DISINFECTION- 24 HOURS
7. LKC/ TOWN OF CARTHAGE AND NCDOT HAVE RIGHT-OF-ENTRY TO THE PROJECT SITE.
8. THE PROPOSED PIPELINE SHALL BE INSTALLED AT THE DEPTHS SHOWN IN THE PROFILE TO AVOID HIGH POINTS THAT CAN TRAP AIR. ALL COST FOR INSTALLATION IN DEEPER CUTS SHALL BE CONSIDERED INCIDENTAL TO THE PROJECT AND SHOULD BE INCLUDED IN THE PRICE FOR FORCE MAIN INSTALLATION.



PROJECT REFERENCE NO. BR-0035	SHEET NO. UC-3B
DESIGNED BY: MRJ	
DRAWN BY: ALH	
CHECKED BY: MRJ	
APPROVED BY: DLH	
REVISED:	
NORTH CAROLINA DEPARTMENT OF TRANSPORTATION UTILITIES ENGINEERING SEC. PHONE: (919) 707-6690 FAX: (919) 250-4151	

PROJECT TYPICAL DETAILS (SOUTHERN PINES)

UTILITY CONSTRUCTION

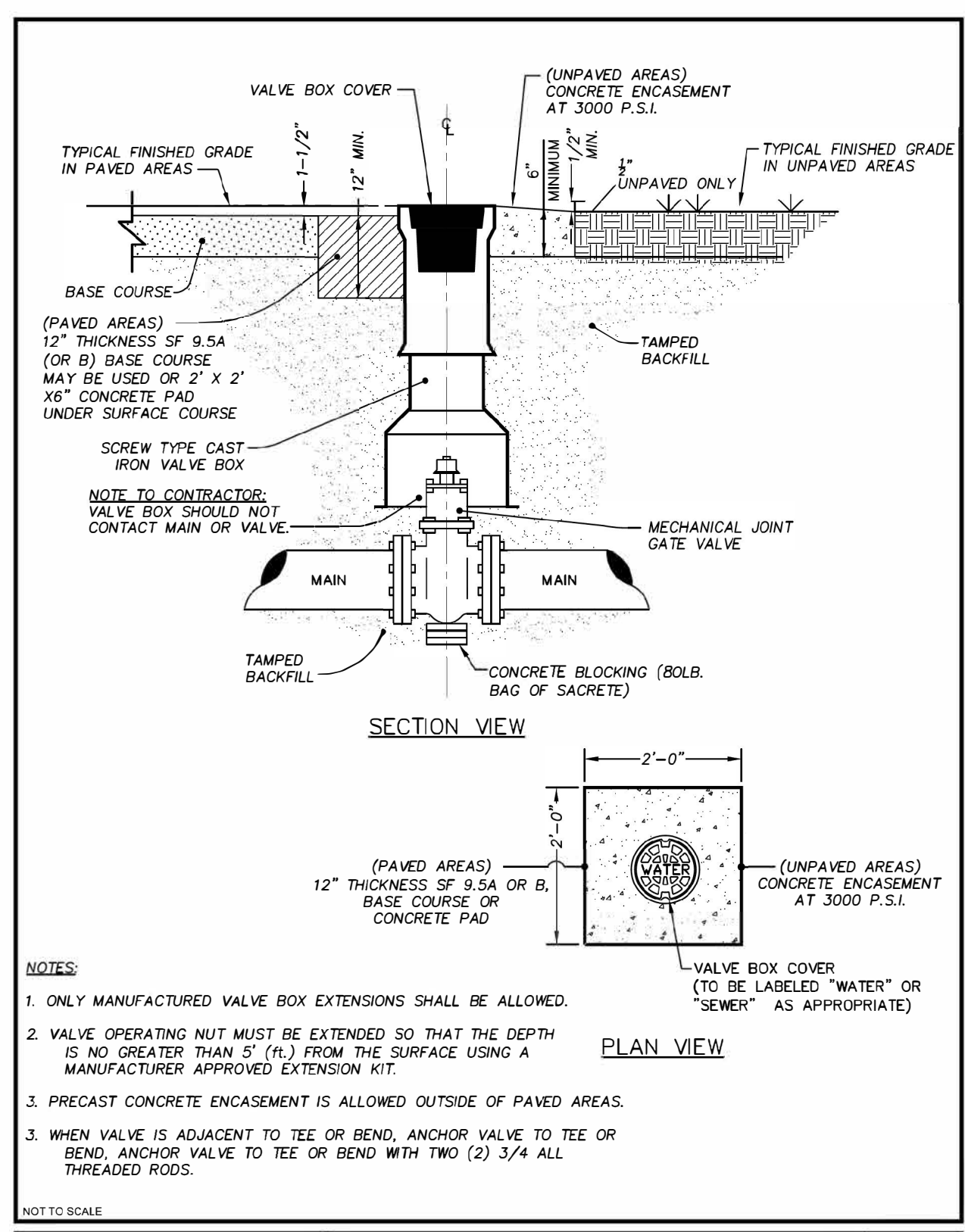

TOWN OF SOUTHERN PINES GATE VALVE ASSEMBLY W-1
DATE: JANUARY 2009

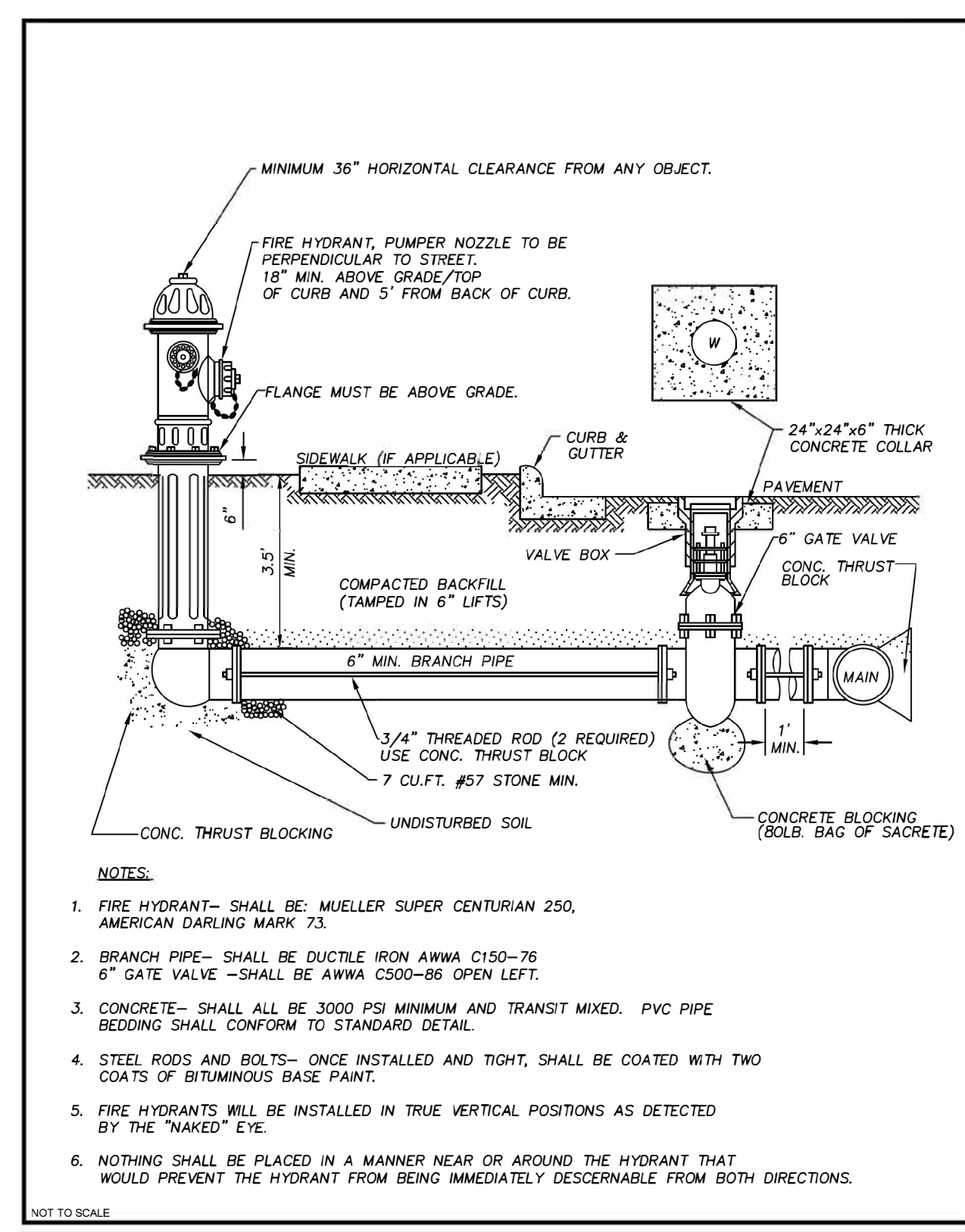

TOWN OF SOUTHERN PINES FIRE HYDRANT ASSEMBLY DETAIL W-5
DATE: JANUARY 2009

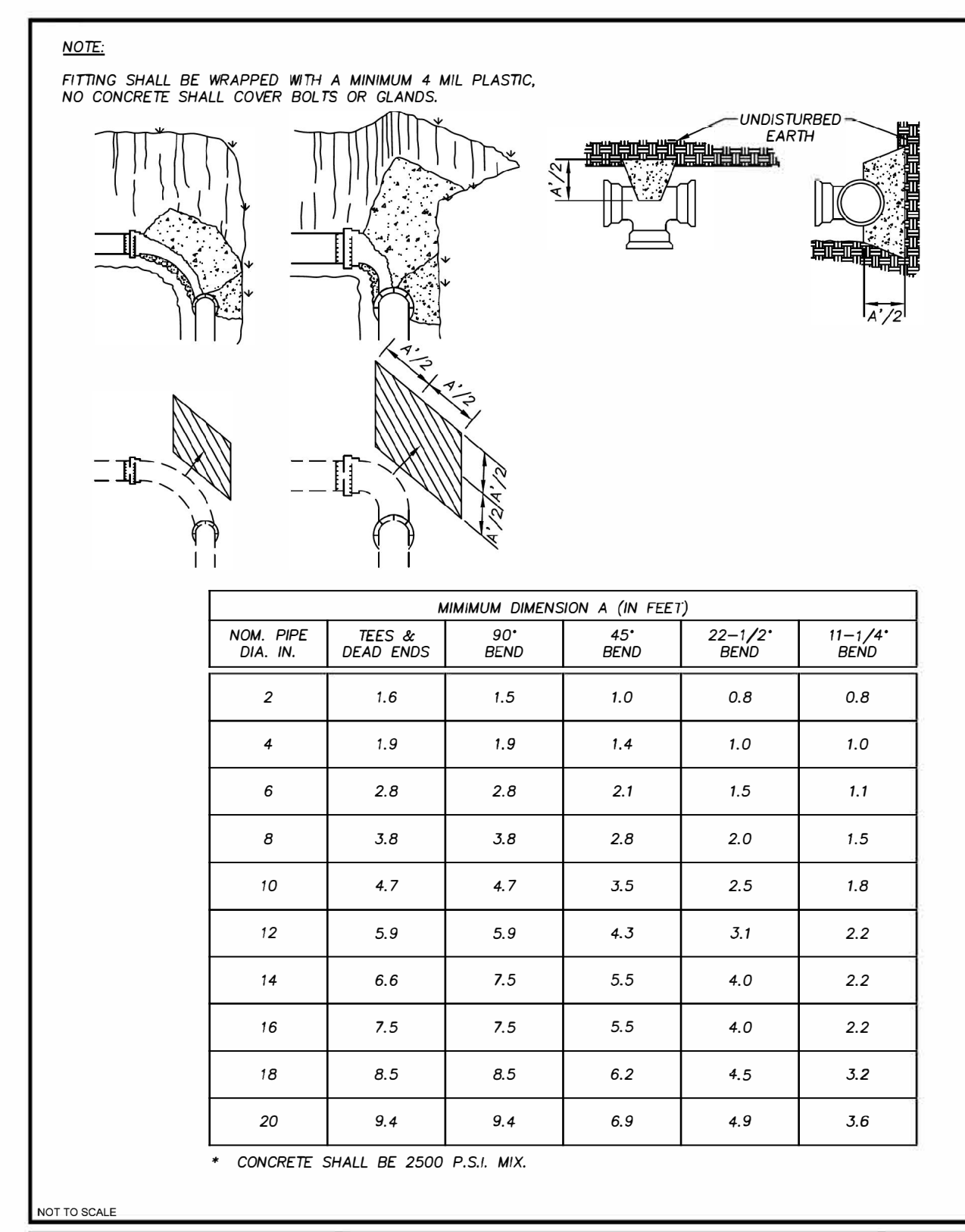

TOWN OF SOUTHERN PINES CONCRETE THURST BLOCK DETAIL W-9
DATE: JANUARY 2009

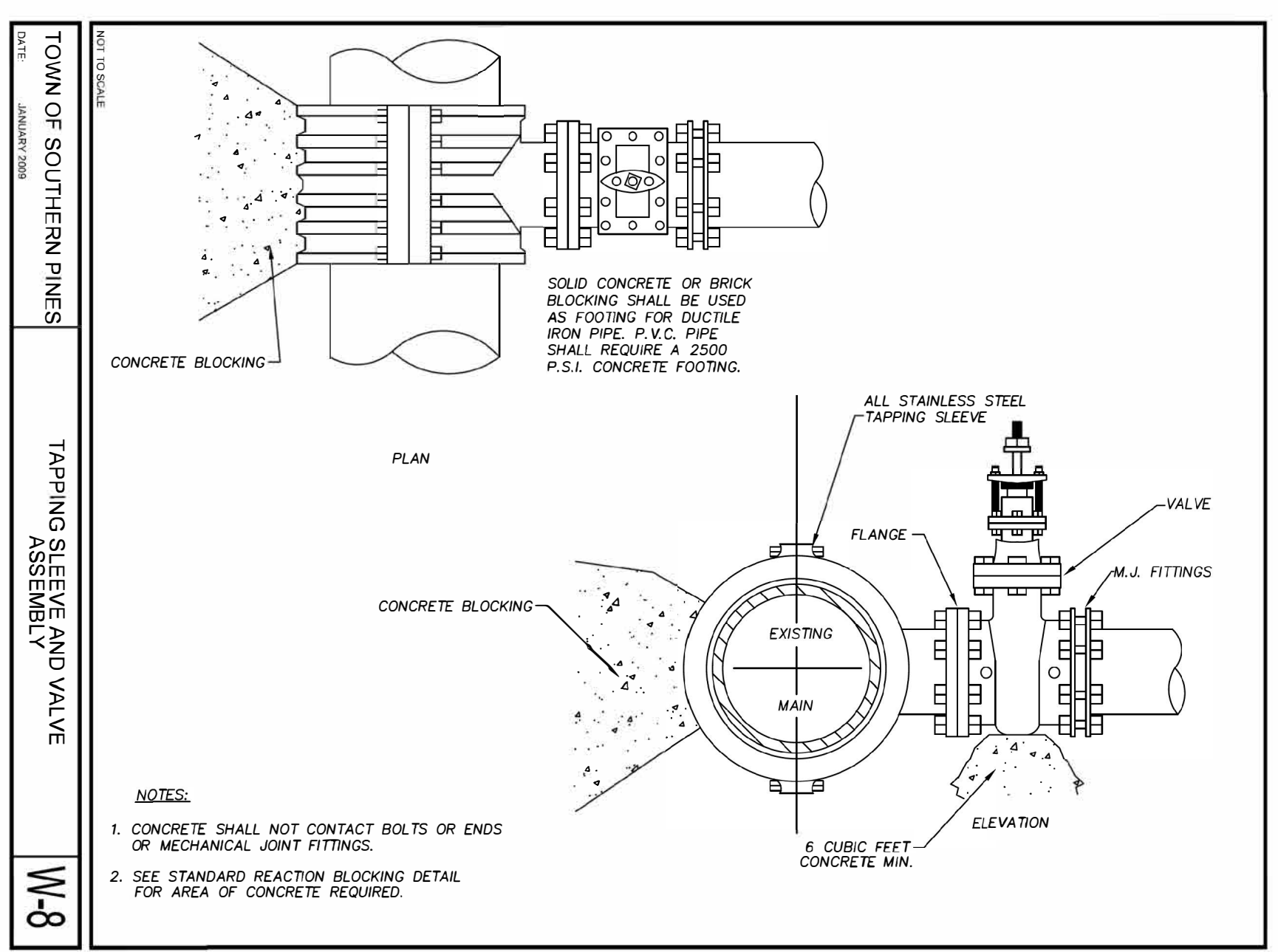

TOWN OF SOUTHERN PINES TAPPING SLEEVE AND VALVE ASSEMBLY W-8
DATE: JANUARY 2009

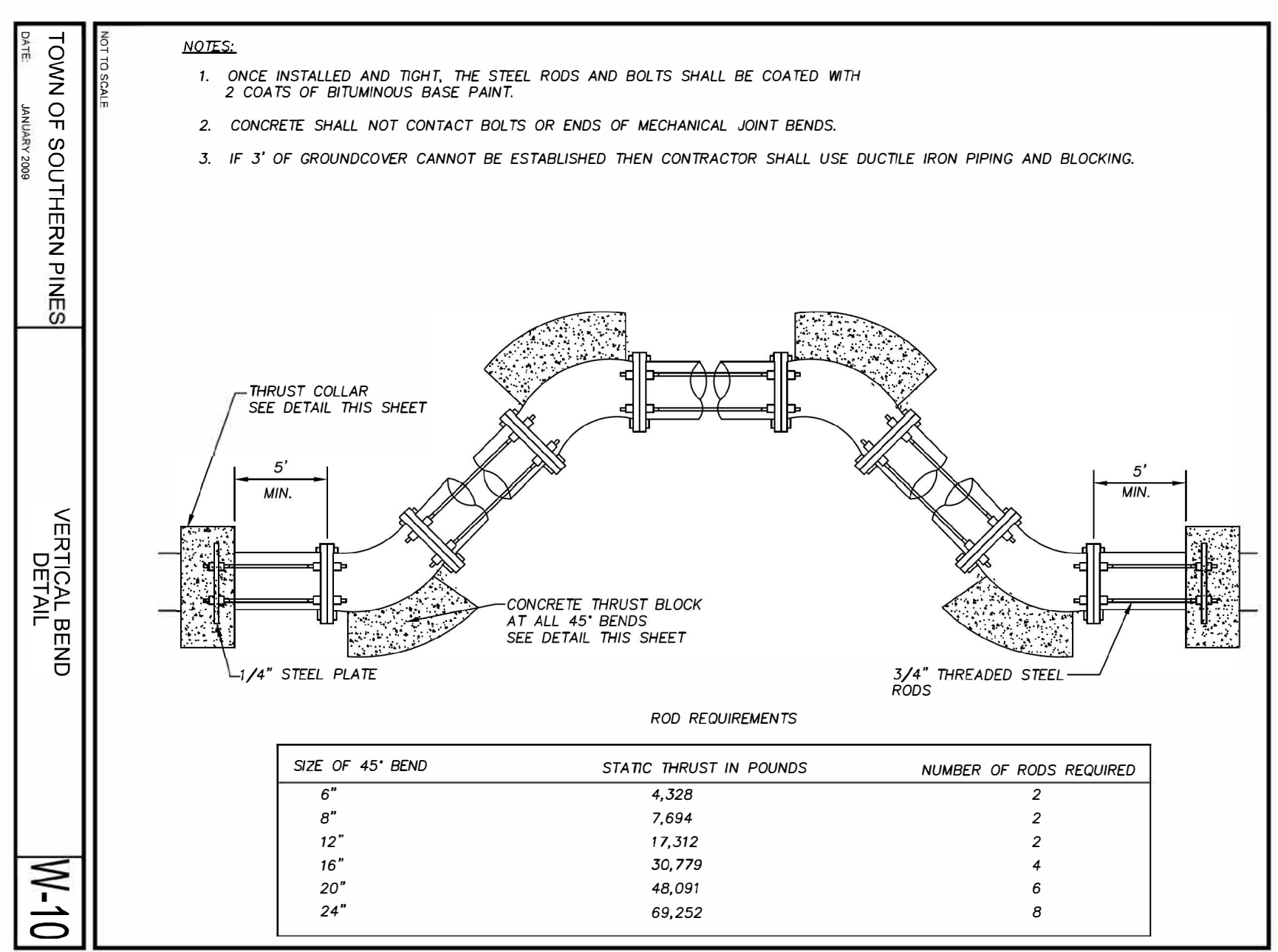

TOWN OF SOUTHERN PINES VERTICAL BEND DETAIL W-10
DATE: JANUARY 2009

01
02
03
04
05
06
07
08
09
10
11
12
13
14
15
16
17
18
19
20
21
22
23
24
25
26
27
28
29
30
31
32
33
34
35
36
37
38
39
40
41
42
43
44
45
46
47
48
49
50
51
52
53
54
55
56
57
58
59
60
61
62
63
64
65
66
67
68
69
70
71
72
73
74
75
76
77
78
79
80
81
82
83
84
85
86
87
88
89
90
91
92
93
94
95
96
97
98
99
00

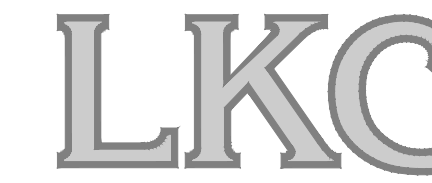

Engineering
Landscape Architecture
Surveying

LKC Engineering, PLLC
140 Aqua Shed Court
Aberdeen, NC 28315
O: 910.420.1437
F: 910.637.0096
lkceengineering.com
License No. P-1095

PROJECT TYPICAL DETAILS

TOWN OF CARTHAGE

PROJECT REFERENCE NO. BR-0035	SHEET NO. UC-3D
DESIGNED BY: MAL	
DRAWN BY: BCS	
CHECKED BY: MAL	
APPROVED BY:	
REVISED:	NORTH CAROLINA DEPARTMENT OF TRANSPORTATION 10/12/2021 UTILITY CONSTRUCTION PLANS ONLY
UTILITY CONSTRUCTION	
DOCUMENT NOT CONSIDERED FINAL UNLESS ALL SIGNATURES COMPLETED	

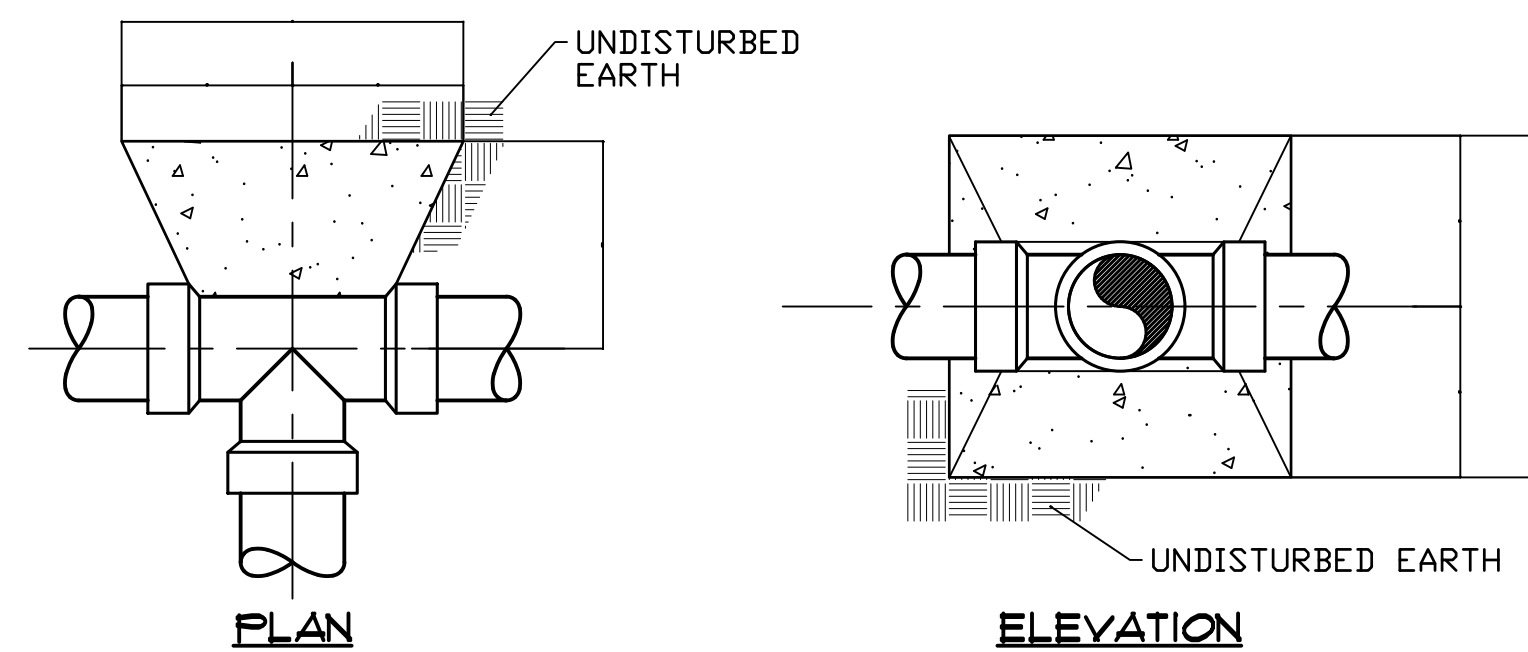
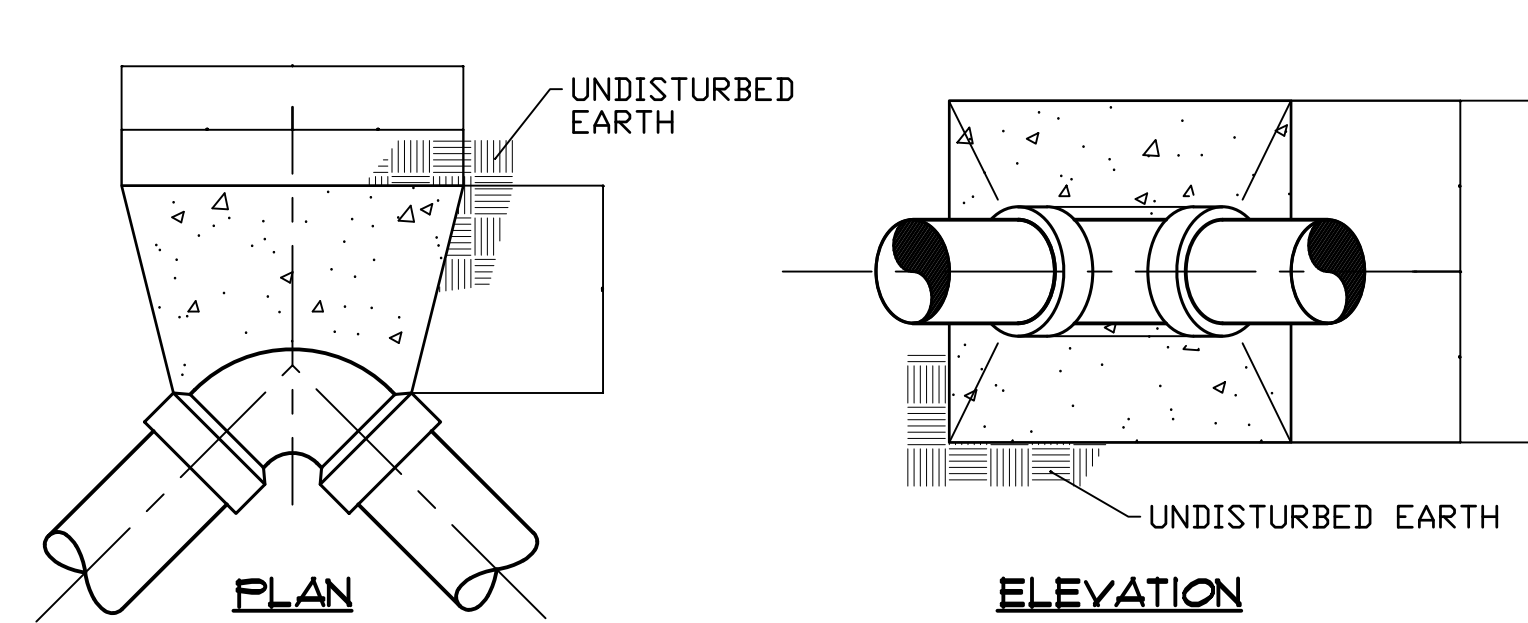

- NOTES:
1. THRUST BLOCKS SHALL BE CONSTRUCTED OF 2500 P.S.I. CONCRETE.
2. INSTALL TAR PAPER AROUND BEND OR FITTING TO PREVENT BONDING OF CONCRETE.

BEND / FITTING	DIMENSION A (FEET)								
	PIPE SIZE (NOM. DIA. IN INCHES)								
	4	6	8	10	12	16	18	20	24
90° BEND	1.4	2.0	2.7	3.4	4.0	5.4	6.0	6.7	8.0
45° BEND	1.0	1.5	2.0	2.5	3.0	4.0	4.5	5.0	5.9
22 1/2° BEND	0.8	1.1	1.5	1.8	2.2	2.9	3.2	3.6	4.3
11 1/4° BEND	0.5	0.8	1.0	1.3	1.5	2.0	2.3	2.5	3.0
TEE BRANCH/DEAD END	1.2	1.7	2.3	2.9	3.4	4.5	5.1	5.7	6.8

**CONCRETE THRUST BLOCK DETAIL
FOR PRESSURE MAIN HORIZONTAL BENDS AND TEES**
N.T.S.

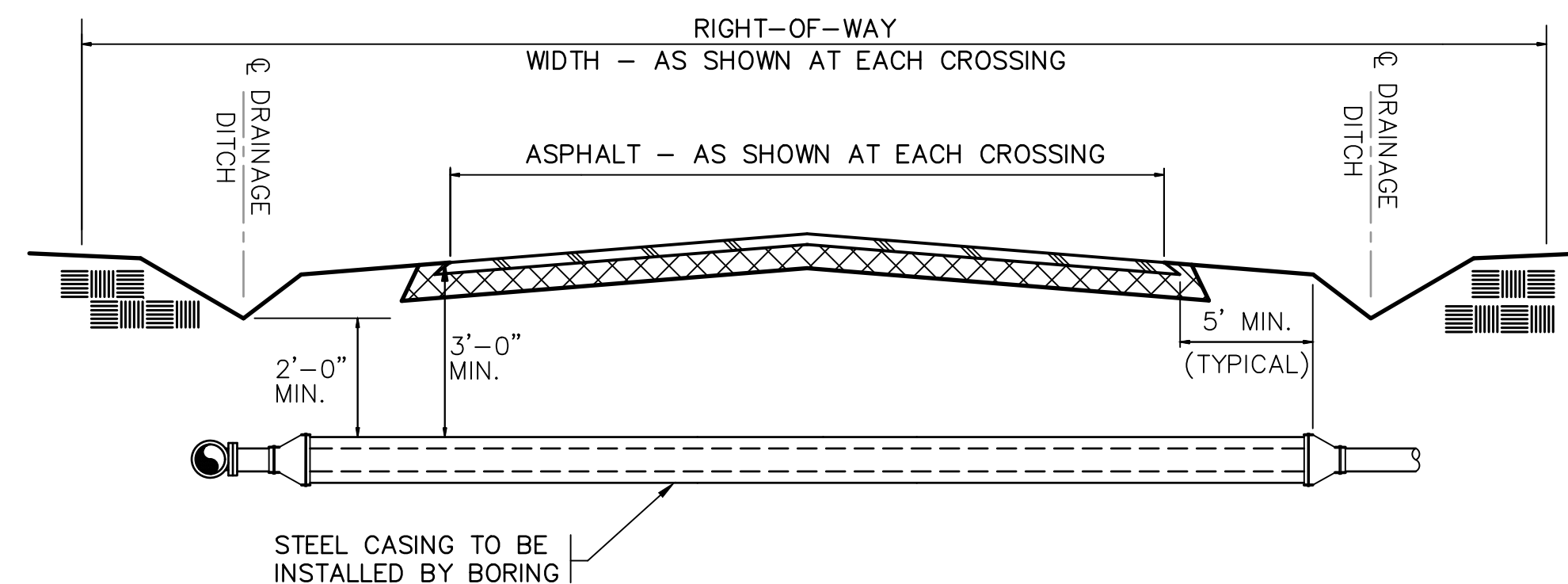
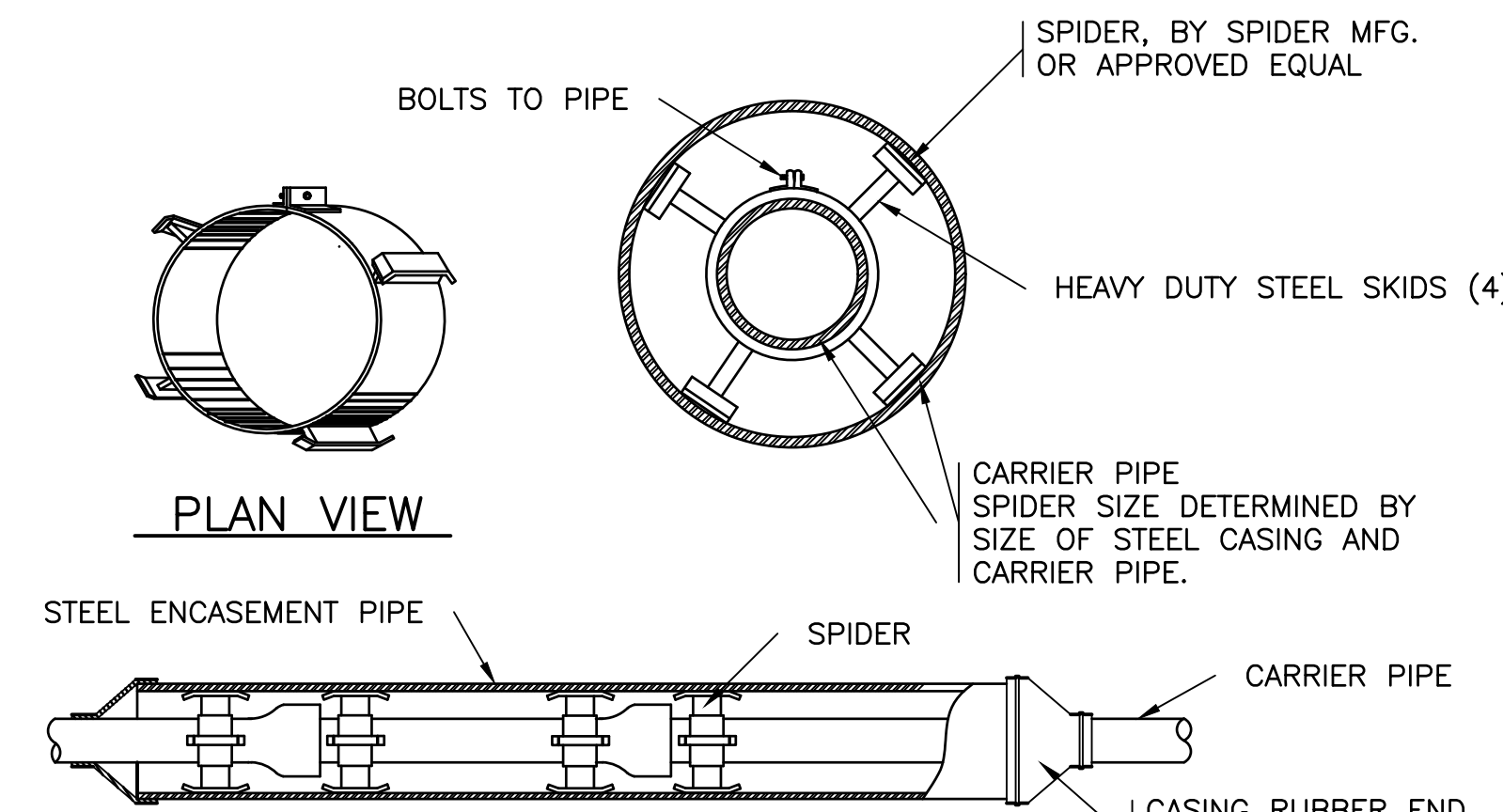

NOMINAL D.I. CARRIER PIPE DIA. (INCHES)	STEEL CASING MINIMUM O.D. (INCHES)	MIN. WALL THICKNESS FOR HIGHWAYS (INCHES)	MIN. WALL THICKNESS FOR RAILROADS (INCHES)
3	8.625	0.250	0.250
4	10.750	0.250	0.250
6	14.0	0.250	0.250
8	16.0	0.250	0.312
10	18.0	0.250	0.312
12	20.0	0.250	0.375
14	24.0	0.250	0.375
16	26.0	0.312	0.500
18	28.0	0.312	0.500
20	30.0	0.312	0.500
24	34.0	0.500	0.625

NOTE:
BEDDING SHALL BE 4" MINIMUM LOOSE SOIL, FREE FROM ROCKS, AND SHALL PROVIDE UNIFORM SUPPORT FOR THE FULL LENGTH OF PIPE.

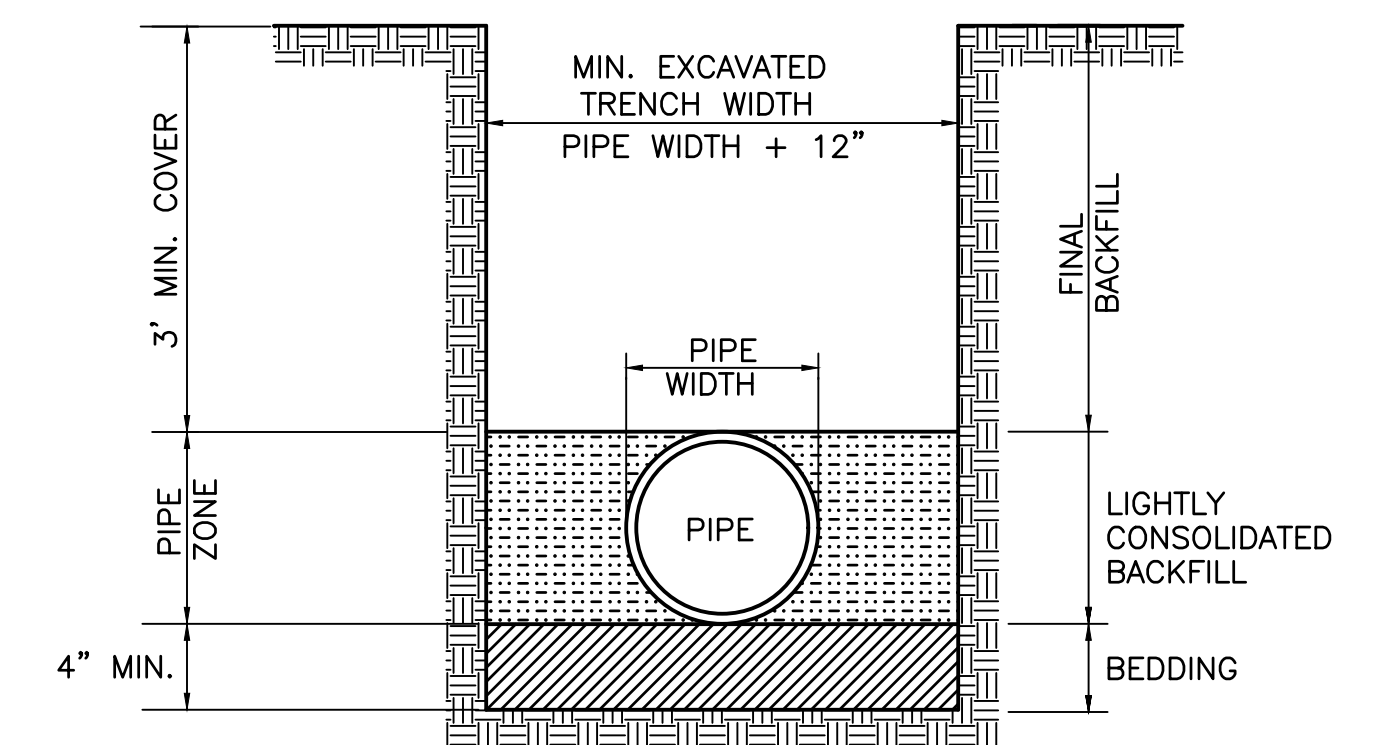

**TRENCH DETAIL
TYPE 3 LAYING CONDITIONS**
N.T.S.

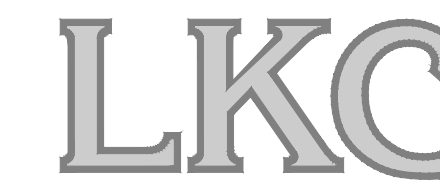

Engineering
Landscape Architecture
Surveying

LKC Engineering, PLLC
140 Aqua Shed Court
Aberdeen, NC 28315
O: 910.420.1437
F: 910.637.0096
lkceengineering.com
License No. P-1095

PROJECT TYPICAL DETAILS

TOWN OF CARTHAGE

PROJECT REFERENCE NO.	SHEET NO.
BR-0035	UC-3E
DESIGNED BY: MAL	
DRAWN BY: BCS	
CHECKED BY: MAL	
APPROVED BY:	
REVISED:	
NORTH CAROLINA DEPARTMENT OF TRANSPORTATION	10/12/2021
UTILITIES ENGINEERING SEC. PHONE: (919) 707-6690 FAX: (919) 250-4151	UTILITY CONSTRUCTION PLANS ONLY
UTILITY CONSTRUCTION	
DOCUMENT NOT CONSIDERED FINAL UNLESS ALL SIGNATURES COMPLETED	

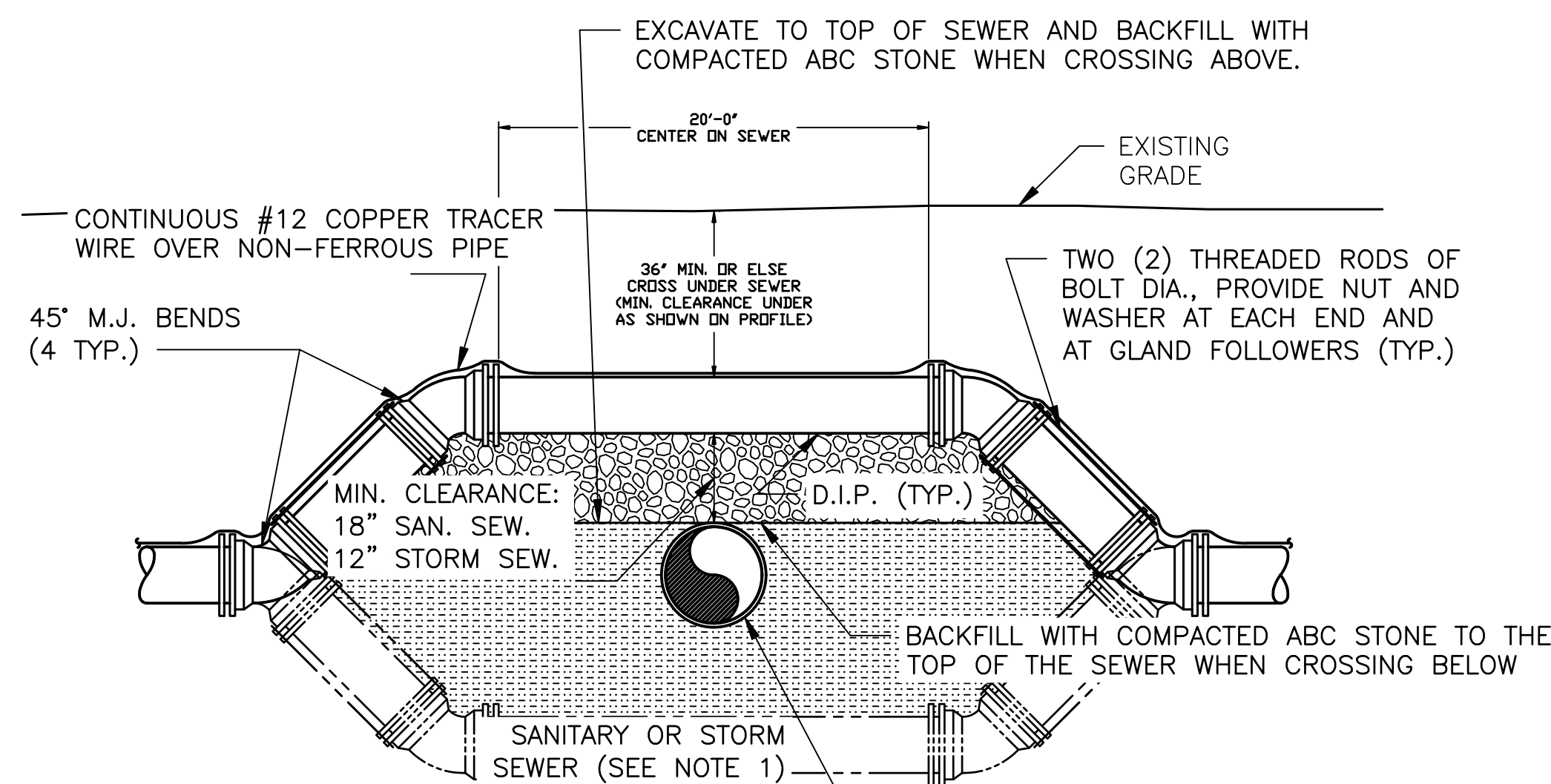

NOTES:

1. WHEN IT IS NECESSARY FOR A WATER MAIN TO CROSS UNDER A SEWER, BOTH THE WATER MAIN AND THE SEWER SHALL BE CONSTRUCTED OF FERROUS MATERIALS AND WITH JOINTS EQUIVALENT TO WATER MAIN STANDARDS FOR A DISTANCE OF 10 FEET ON EACH SIDE OF THE POINT OF CROSSING. A SECTION OF WATER MAIN PIPE SHALL BE CENTERED AT THE POINT OF CROSSING.
2. ALLOWABLE PIPE AND/OR JOINT DEFLECTIONS MAY BE USED IN LIEU OF BENDS TO ACHIEVE REQUIRED CLEARANCE OVER OR UNDER SEWER.

SANITARY AND STORM SEWER CROSSING DETAIL

N.T.S.

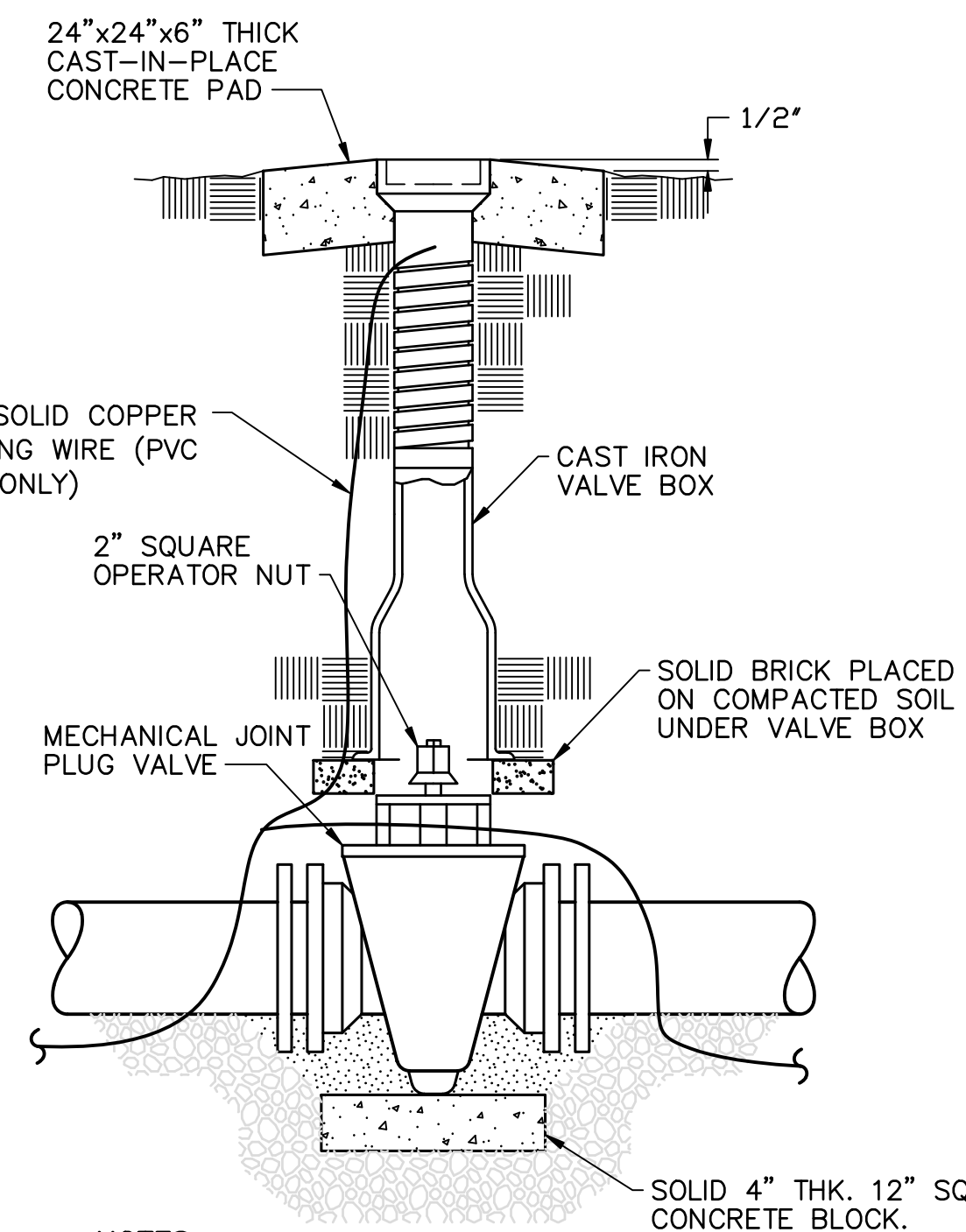

NOTES:

1. PLACE PLUG VALVES ON 4" CONCRETE BLOCK.
2. WHERE PVC PIPE IS BEING INSTALLED, 6 IN. OF COMPACTED #57 STONE MAY BE USED IN LIEU OF THE 4" CONCRETE BLOCK.
3. MAXIMUM SPACING FOR SEWER FORCE MAIN ISOLATION VALVES IS 1,000 LF.

PLUG VALVE ASSEMBLY

N.T.S.

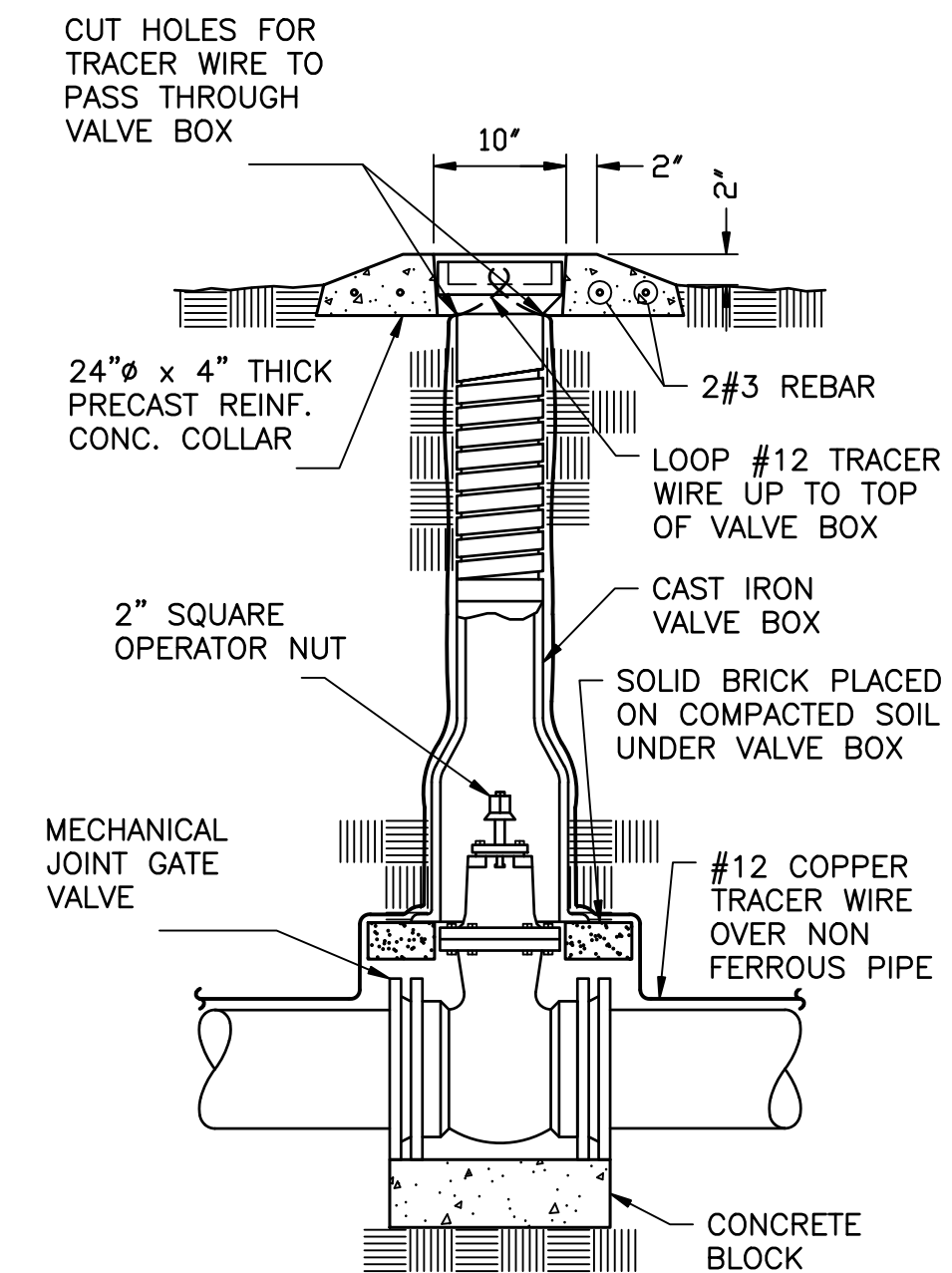

NOTE:

SEPARATION FROM ADJACENT FITTINGS SHOWN ON PLANS AND PROFILES IS FOR CLARITY. ACTUAL SEPARATION MAY BE ADJUSTED TO FIT LAYING CONDITIONS.

GATE VALVE ASSEMBLY

N.T.S.

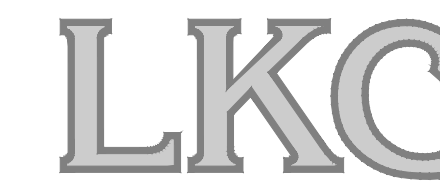

Engineering
Landscape Architecture
Surveying

LKC Engineering, PLLC
140 Aqua Shed Court
Aberdeen, NC 28315
O: 910.420.1437
F: 910.637.0096
lkceengineering.com
License No. P-1095

PROJECT TYPICAL DETAILS

TOWN OF CARTHAGE

PROJECT REFERENCE NO. BR-0035	SHEET NO. UC-3F
DESIGNED BY: MAL	
DRAWN BY: BCS	
CHECKED BY: MAL	
APPROVED BY:	
REVISED:	
NORTH CAROLINA DEPARTMENT OF TRANSPORTATION	10/12/2021 UTILITY CONSTRUCTION PLANS ONLY
UTILITIES ENGINEERING SEC. PHONE: (919) 707-6690 FAX: (919) 250-4151	
UTILITY CONSTRUCTION	
DOCUMENT NOT CONSIDERED FINAL UNLESS ALL SIGNATURES COMPLETED	

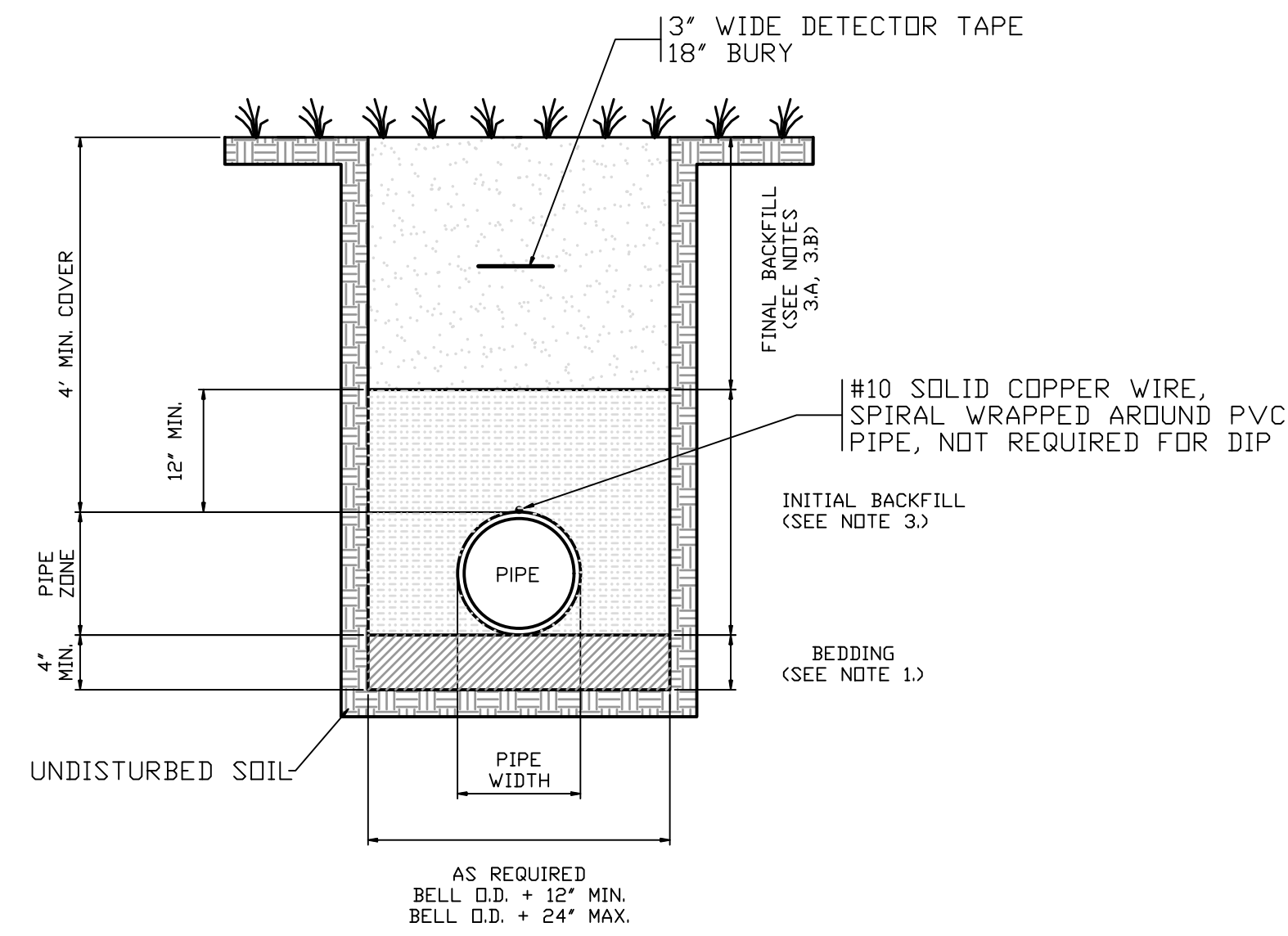

FORCE MAIN TRENCH DETAILS
TYPE 3 LAYING CONDITIONS
N.T.S.

NOTES:

- LAYING CONDITIONS AS PER AWWA C600 AND C605 STANDARDS.
- BEDDING MATERIAL SHALL BE 4" MINIMUM THICKNESS, LOOSE SOIL (DEFINED AS NATIVE SOIL EXCAVATED FROM THE TRENCH), FREE FROM ROCKS AND SHALL PROVIDE UNIFORM SUPPORT FOR THE FULL LENGTH OF PIPE. COMPACT TO 95% MAXIMUM DENSITY.
- INITIAL BACKFILL SHALL BE LIGHTLY CONSOLIDATED IN MAXIMUM 6" LOOSE LIFTS, COMPACTED TO 95% OF MAXIMUM DENSITY.
- UNDER AREAS TO BE SEEDED OR SODDED, COMPACT SUCCEEDING LAYERS OF FINAL BACKFILL IN 12" LOOSE LIFTS TO 85% MAXIMUM DENSITY.
- UNDER STRUCTURES, PAVEMENTS AND ROAD SHOULDERS, COMPACT SUCCEEDING LAYERS OF FINAL BACKFILL IN 6" LOOSE LIFTS TO 95% MAXIMUM DENSITY EXCEPT COMPACT TOP 12" OF SUBGRADE TO 98% MAXIMUM DENSITY.
- PROVIDE #10 SOLID COPPER WIRE IN SUFFICIENT LENGTH TO BE CONTINUOUS OVER EACH SEPARATE RUN OF ALL BURIED PVC PIPING. AT VALVE BOXES, BRING WIRE TO WITHIN 6 IN. OF TOP OF BOX AND INSERT INTO BOX THROUGH DRILLED HOLE. NOT REQUIRED FOR DUCTILE IRON PIPE.
- INSTALL 3' WIDE DETECTOR TAPE AT 18" DEPTH. TAPE SHALL HAVE MIDDLE FOIL LAYER.

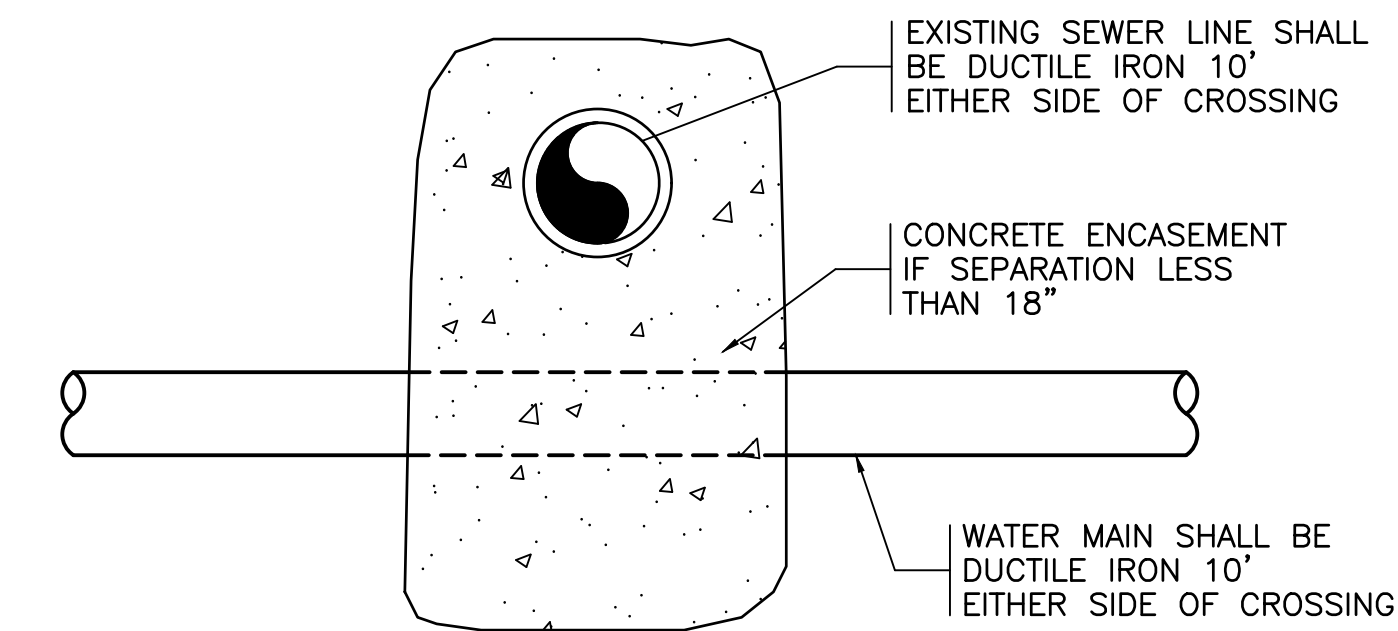

SEWER AND WATER CROSSING
N.T.S.

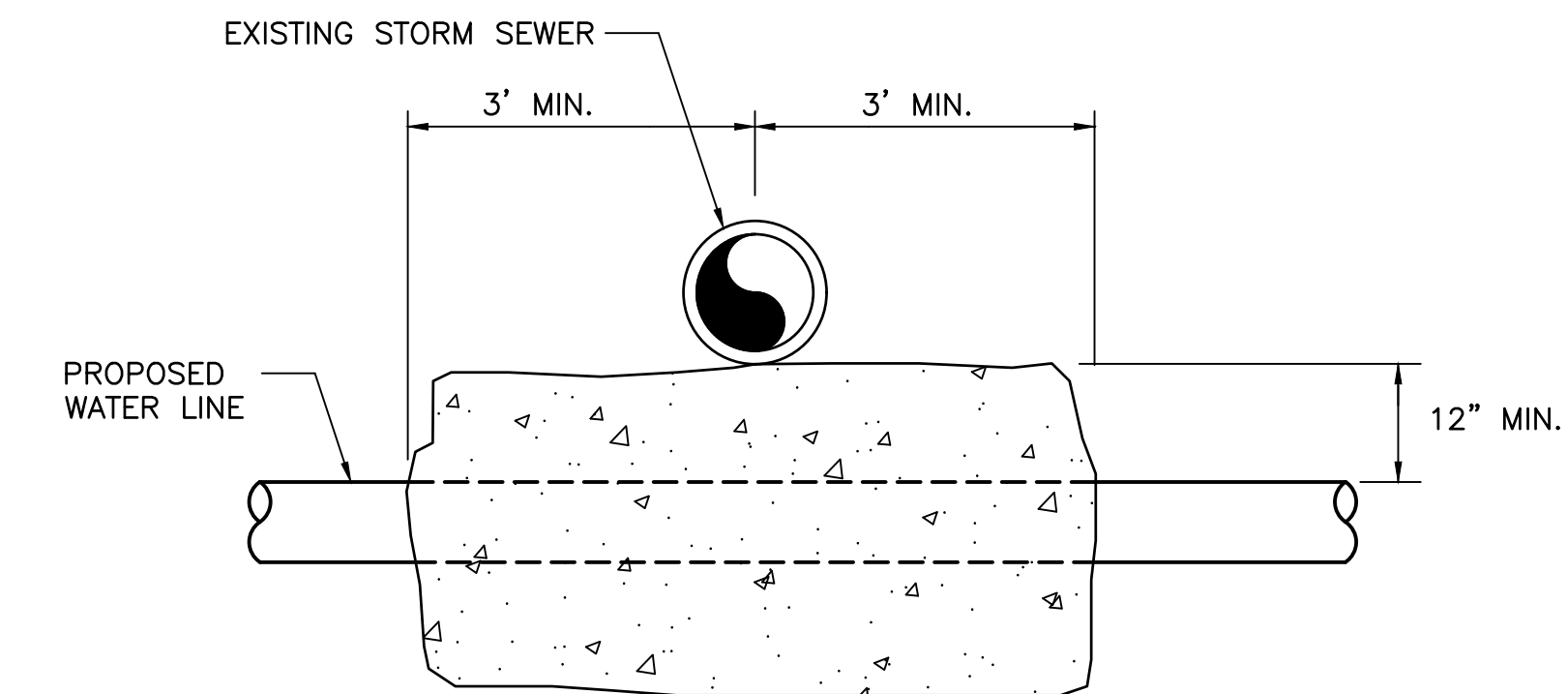

STORM SEWER CROSSING
N.T.S.

NOTE:
12" CONC. ENCASEMENT ALL AROUND PROPOSED WATER LINE AND Poured TO THE BOTTOM OF THE EXISTING PIPE.

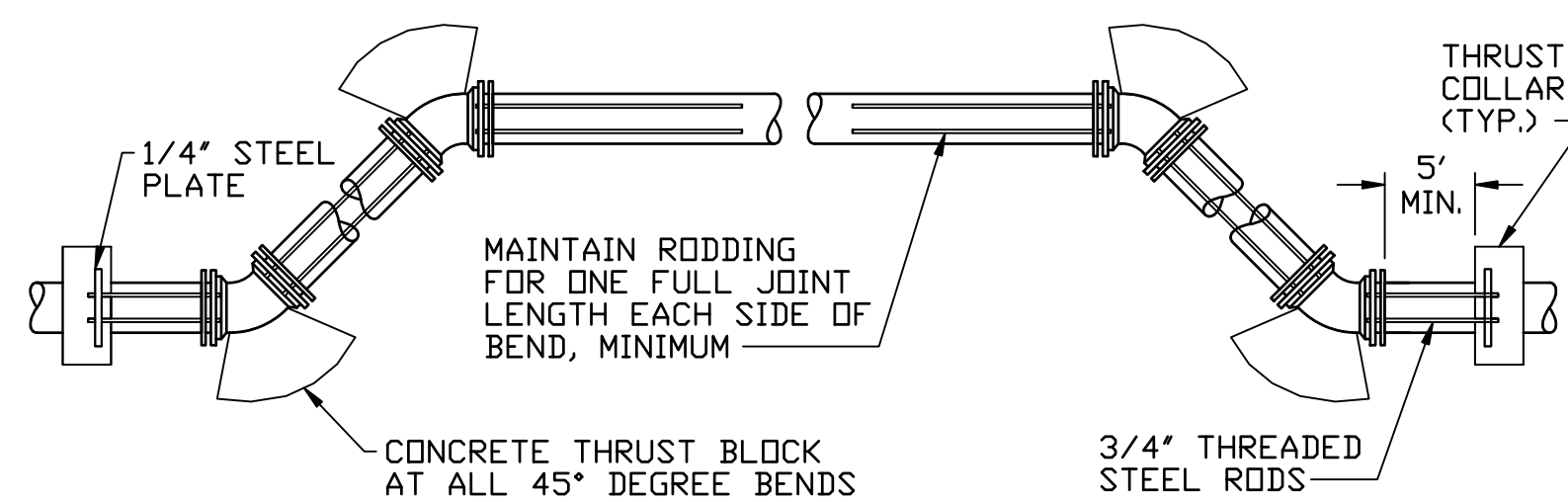

STATIC THRUST SIZE OF 45° BEND	NUMBER OF IN POUNDS	NUMBER OF RODS REQUIRED
6"	4,328	2
8"	7,694	2
12"	17,312	4
16"	30,779	4
20"	48,091	6
24"	69,252	8

NOTES:

- ONCE INSTALLED AND TIGHT, THE STEEL RODS AND BOLTS SHALL RECEIVE 2 COATS OF BITUMINOUS MATERIAL OR SHALL BE GALVANIZED.
- CONCRETE SHALL NOT CONTACT BOLTS OR ENDS OF MECHANICAL JOINT BENDS.

VERTICAL BENDS
N.T.S.

PROJECT TYPICAL DETAILS

TOWN OF CARTHAGE



PROJECT REFERENCE NO.	SHEET NO.
BR-0035	UC-3G
DESIGNED BY: MAL	
DRAWN BY: BCS	
CHECKED BY: MAL	
APPROVED BY:	
REVISED:	
NORTH CAROLINA DEPARTMENT OF TRANSPORTATION UTILITIES ENGINEERING SECTION PHONE: (919) 707-6690 FAX: (919) 250-4151	
10/12/2021 UTILITY CONSTRUCTION PLANS ONLY	
UTILITY CONSTRUCTION DOCUMENT NOT CONSIDERED FINAL UNLESS ALL SIGNATURES COMPLETED	

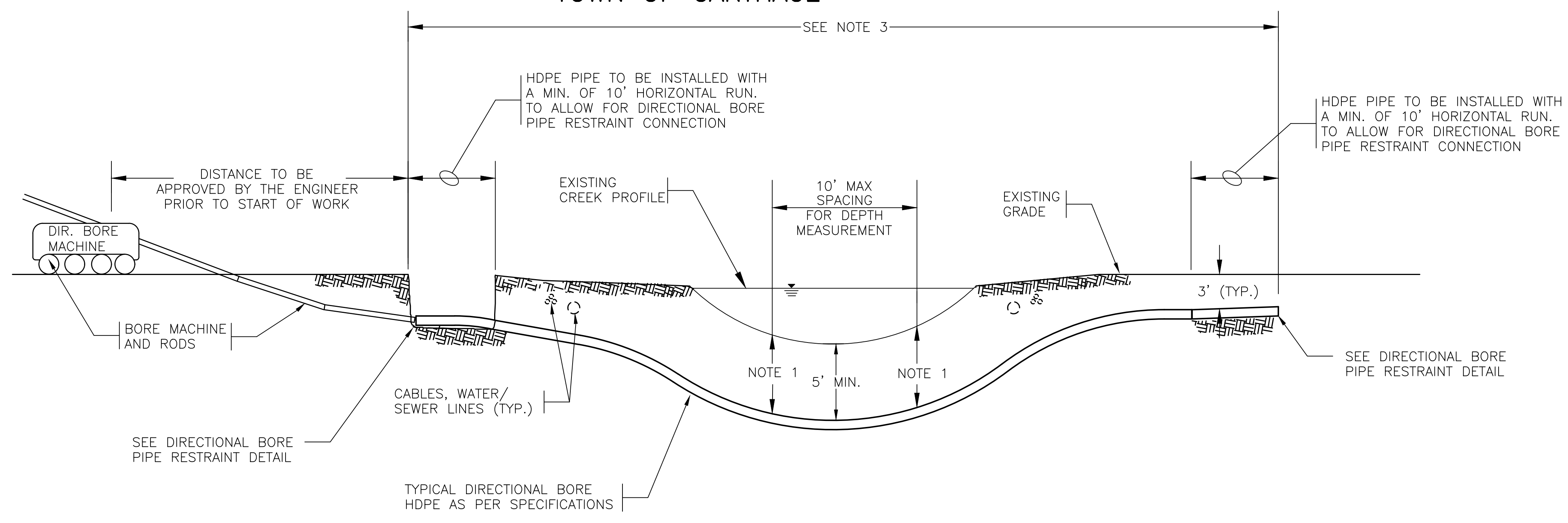

TYPICAL DIRECTIONAL BORE FOR HIGH-DENSITY POLYETHYLENE (HDPE) PIPE

N.T.S.

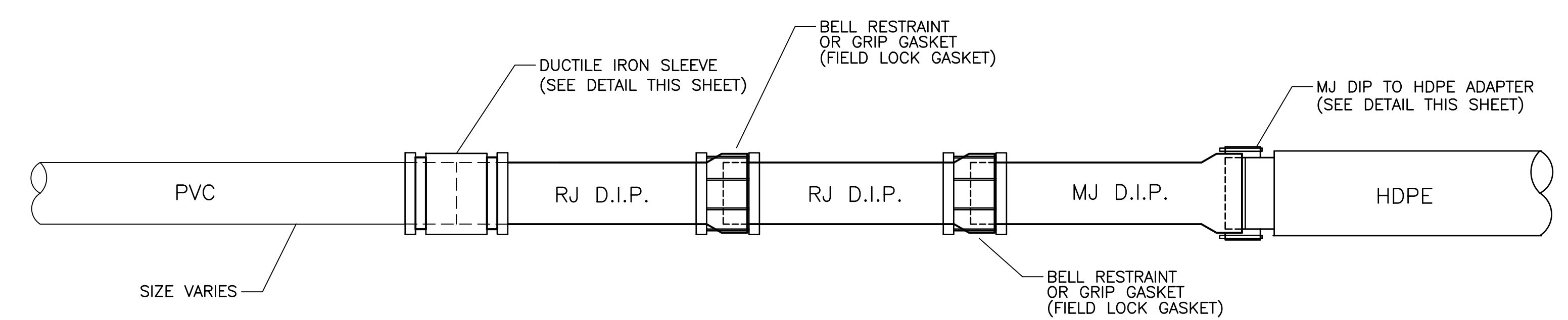

DIRECTIONAL BORE PIPE RESTRAINT

N.T.S.

NOTES:

1. A PROFILE AND PLAN SHALL BE PROVIDED FROM ENTRY TO EXIT FOR EACH DIRECTIONAL BORE SECTION BY THE DIRECTIONAL BORE CONTRACTOR.
2. ALL BORE SECTIONS SHALL BE HYDROSTATICALLY TESTED PER SPECIFICATION STANDARDS UPON COMPLETION OF INSTALLATION AND PRIOR TO PLACING HDPE IN SERVICE.
3. LENGTH OF CROSSING, LOCATION OF INSPECTION/OBSERVATION EXCAVATION, NUMBER OF PIPE JOINTS, LOCATION OF BORE MACHINE, AUGER ENTRANCE LOCATION, AND TIE-IN POINTS ARE TO BE APPROVED BY THE ENGINEER PRIOR TO ANY START OF WORK.
4. THIS DETAIL IS ALSO APPLICABLE TO STREAMS, WETLANDS, LARGE STORM DRAINS, AND SIMILAR APPLICATIONS FOR DIRECTIONAL BORE WITH POLY-ETHYLENE PIPE.
5. THE BORE DEVELOPED FOR THE LEAD IN END OF THE PIPE SHALL BE KEPT AT A MINIMUM DIAMETER FOR THE PIPE INSTALLATION. THE LEAD IN END SHALL BE PULLED THROUGH WITHOUT THE M.J. FLANGE ATTACHED FOR LARGER THAN 6" PIPE INSTALLATIONS. THE M.J. FLANGE FOR SAID LEAD IN END SHALL BE INSTALLED AFTER THE PIPE INSTALLATION WITH THE USE OF A SPLIT M.J. FLANGE PER THE DETAIL ON THIS DRAWING.

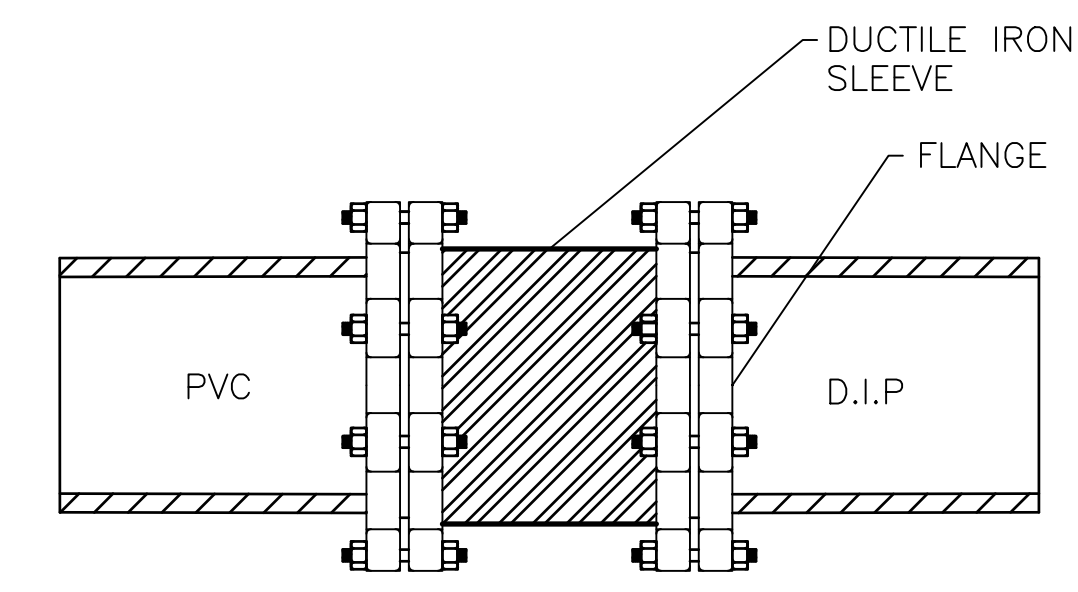

DIP/PVC TRANSITION ASSEMBLY

N.T.S.

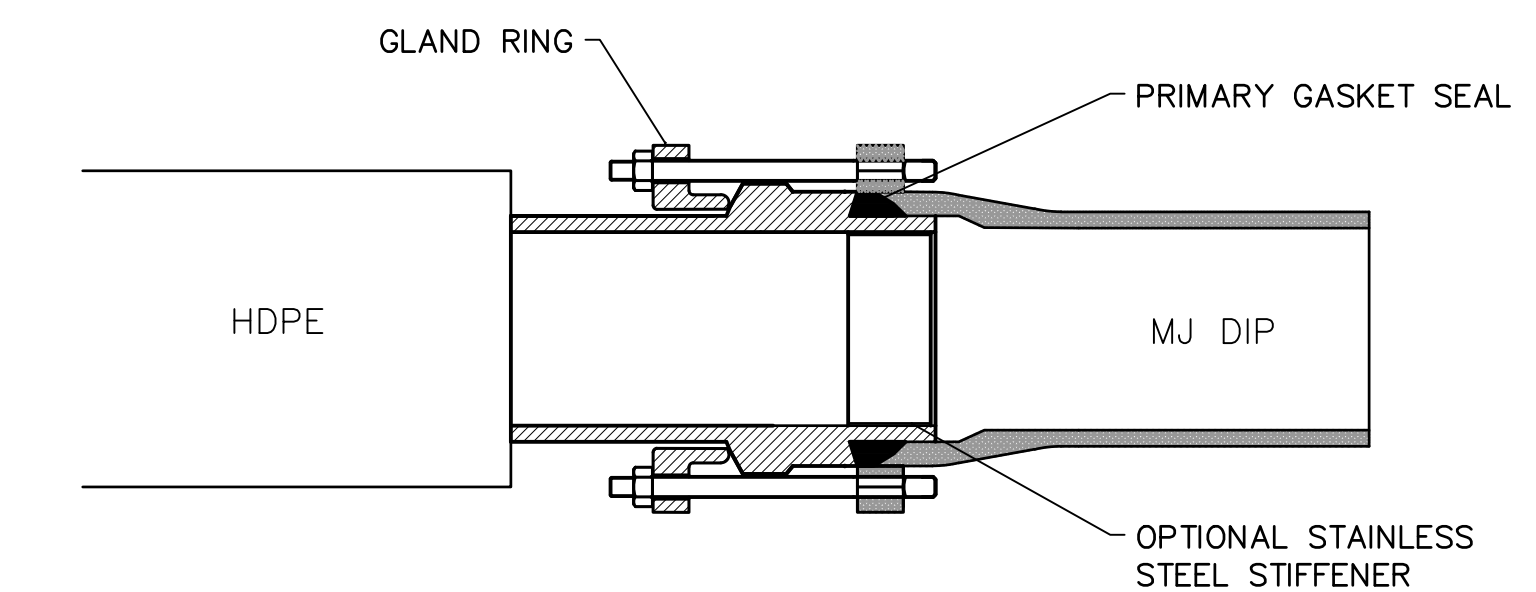

HDPE TO MECHANICAL JOINT ADAPTER

N.T.S.

L:\Cart-19.02_Hwy 22 Utility Relocation\800 - Drawings\DOT\Cart-19.02 Directional Bore Detail.dwg: Last Saved By: BRYAN, 10/6/2021 4:31:31 PM; Layout1: Plotted By: Bryn Stone, 10/07/21 02:09:48 PM
 No Xrefs; IMAGE; No Images

PROJECT REFERENCE NO.	SHEET NO.
BR-0035	UC-4
DESIGNED BY: MRJ	
DRAWN BY: ALH	
CHECKED BY: MRJ	
APPROVED BY: DLH	
REVISED:	
NORTH CAROLINA DEPARTMENT OF TRANSPORTATION UTILITIES ENGINEERING SEC. PHONE: (919) 707-6690 FAX: (919) 250-4151	
UTILITY CONSTRUCTION PLANS ONLY	

THE ESTIMATED QUANTITY OF DUCTILE IRON WATER PIPE FITTINGS ON THIS PLAN SHEET IS 1,115 POUNDS. THE ACTUAL QUANTITY AND TYPE OF FITTINGS WILL VARY BASED ON FIELD CONDITIONS.

UTILITY CONSTRUCTION

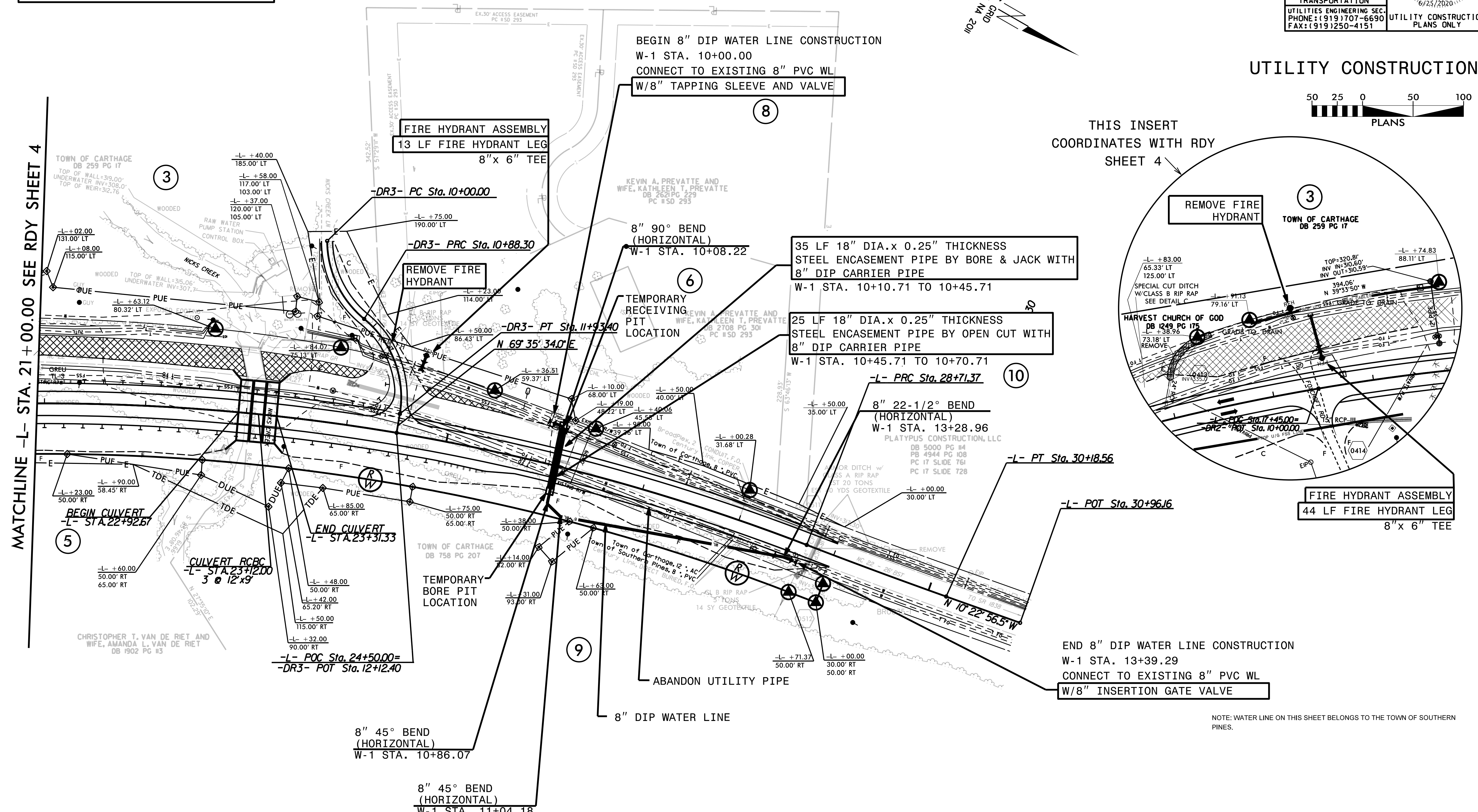

THIS INSERT COORDINATES WITH RDY SHEET 4

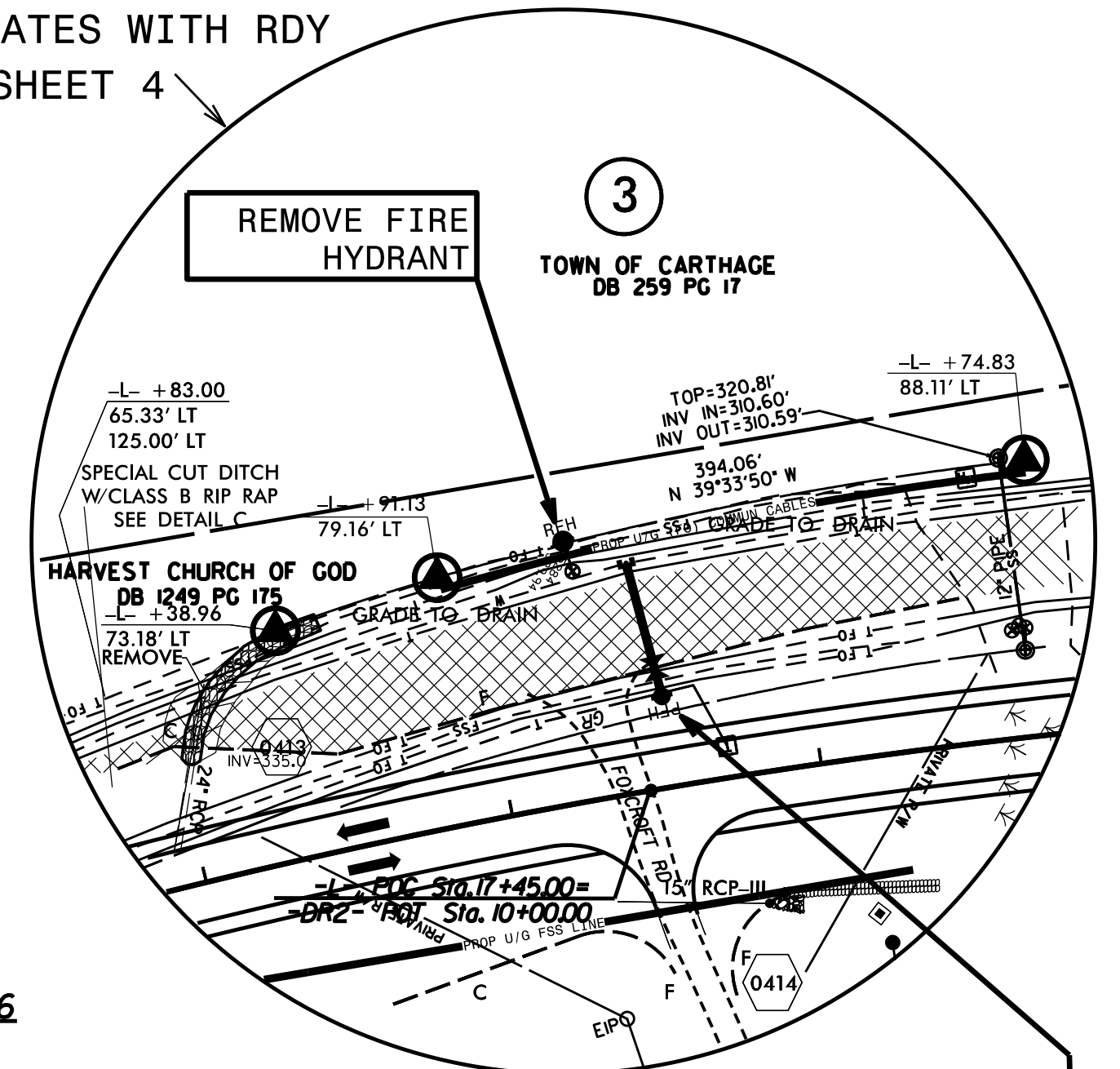

FIRE HYDRANT ASSEMBLY 44 LF FIRE HYDRANT LEG 8" x 6" TEE

NOTE: WATER LINE ON THIS SHEET BELONGS TO THE TOWN OF SOUTHERN PINES.

PROPOSED 60 LF OF 18" STEEL ENCASEMENT PIPE
 ABANDON EXISTING 8" WATER MAIN SHEET UC-4
 TOTAL LENGTH = 307 LF

PROPOSED 280 LF OF 8" WATER MAIN
 PROPOSED 60 LF OF 8" CARRIER PIPE

MATCHLINE -L- STA. 21+00.00 SEE RDY SHEET 4

UTILITY CONSTRUCTION PLANS ONLY

3/31/20



PROJECT REFERENCE NO. BR-0035	SHEET NO. UC-5
DESIGNED BY: MWJ	
DRAWN BY: ALH	
CHECKED BY: MWJ	
APPROVED BY: DLH	
REVISED:	
NORTH CAROLINA DEPARTMENT OF TRANSPORTATION	
UTILITIES ENGINEERING SEC. PHONE: (919) 707-6690 FAX: (919) 250-4151	UTILITY CONSTRUCTION PLANS ONLY
DOCUMENT NOT CONSIDERED FINAL UNTIL ALL SIGNATURES ARE COMPLETED	

WATER LINE W-1 PROFILE

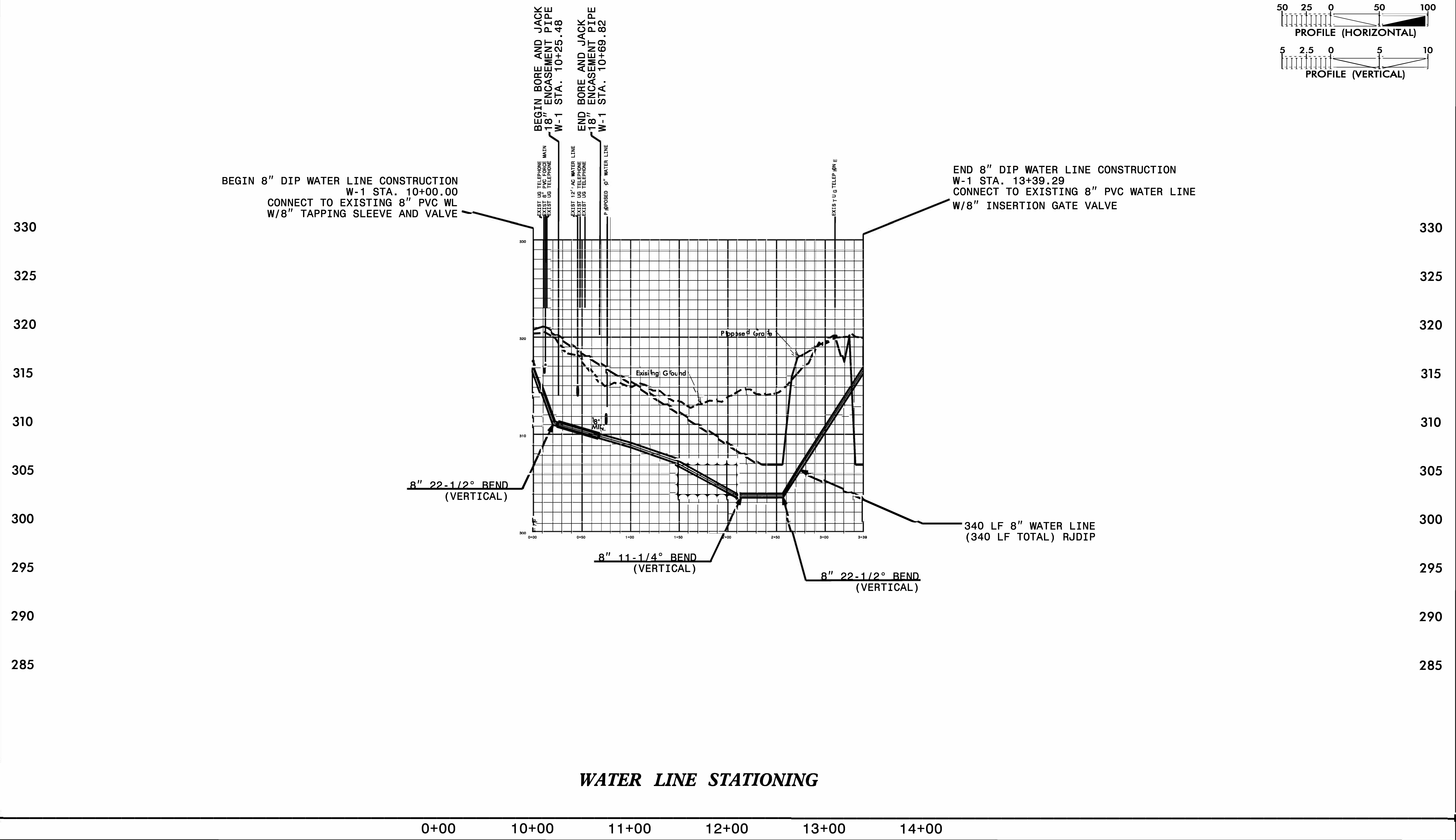
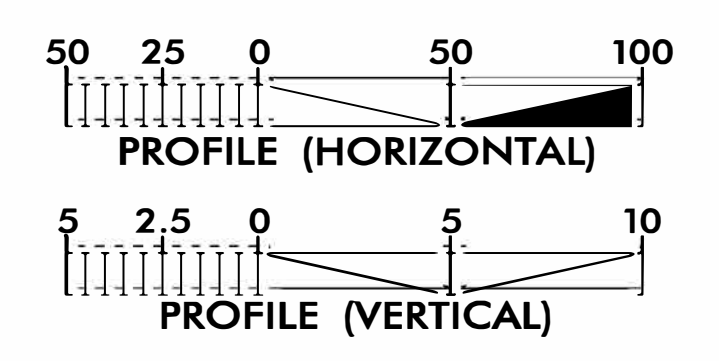

\$\$\$\$\$SYTIME\$\$\$\$\$
\$\$\$\$\$SERNAME\$\$\$\$\$

8/17/99

THE ESTIMATE QUANTITY OF DUCTILE IRON SEWER MAIN FITTING ON THIS PLAN SHEET IS 110 POUNDS. THE ACTUAL QUANTITY WILL VARY BASED UPON FIELD CONDITIONS.



LKC Engineering, PLLC
140 Aqua Street Court
Aberdeen, NC 28313
P: 910.637.0095
F: 910.637.0096
lkcengineering.com
License No. P-1095

PROJECT REFERENCE NO.	SHEET NO.
BR-0035	UC-6
DESIGNED BY: MAL	
DRAWN BY: BCS	
CHECKED BY: MAL	
APPROVED BY: -	
REVISD:	
NORTH CAROLINA DEPARTMENT OF TRANSPORTATION	
UTILITIES ENGINEERING SECTION	
PHONE: (919) 707-6690	10/12/2021
FAX: (919) 250-4151	UTILITY CONSTRUCTION PLANS ONLY
UTILITY CONSTRUCTION	
DOCUMENT NOT CONSIDERED FINAL UNLESS ALL SIGNATURES COMPLETED	

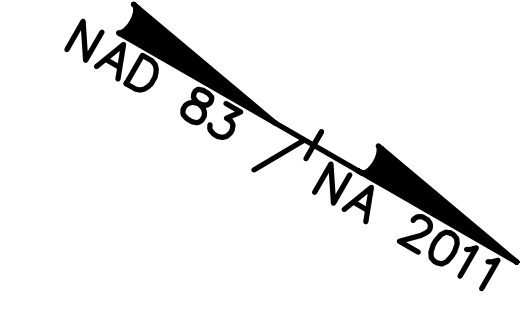

NOTE:
ALL PROPOSED UTILITIES SHALL BE TESTED AND ACCEPTED PRIOR TO MAKING CONNECTION TO EXISTING MAINS.

REVISIONS

PLAN SHEET LAYOUT NESTED_12167
 PLAN SHEET LAYOUT NESTED_12168
 PLAN SHEET LAYOUT NESTED_12169

MATCHLINE - L - STA. 21+00.00 SEE SHEET 5

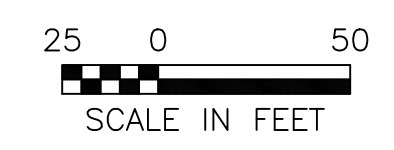
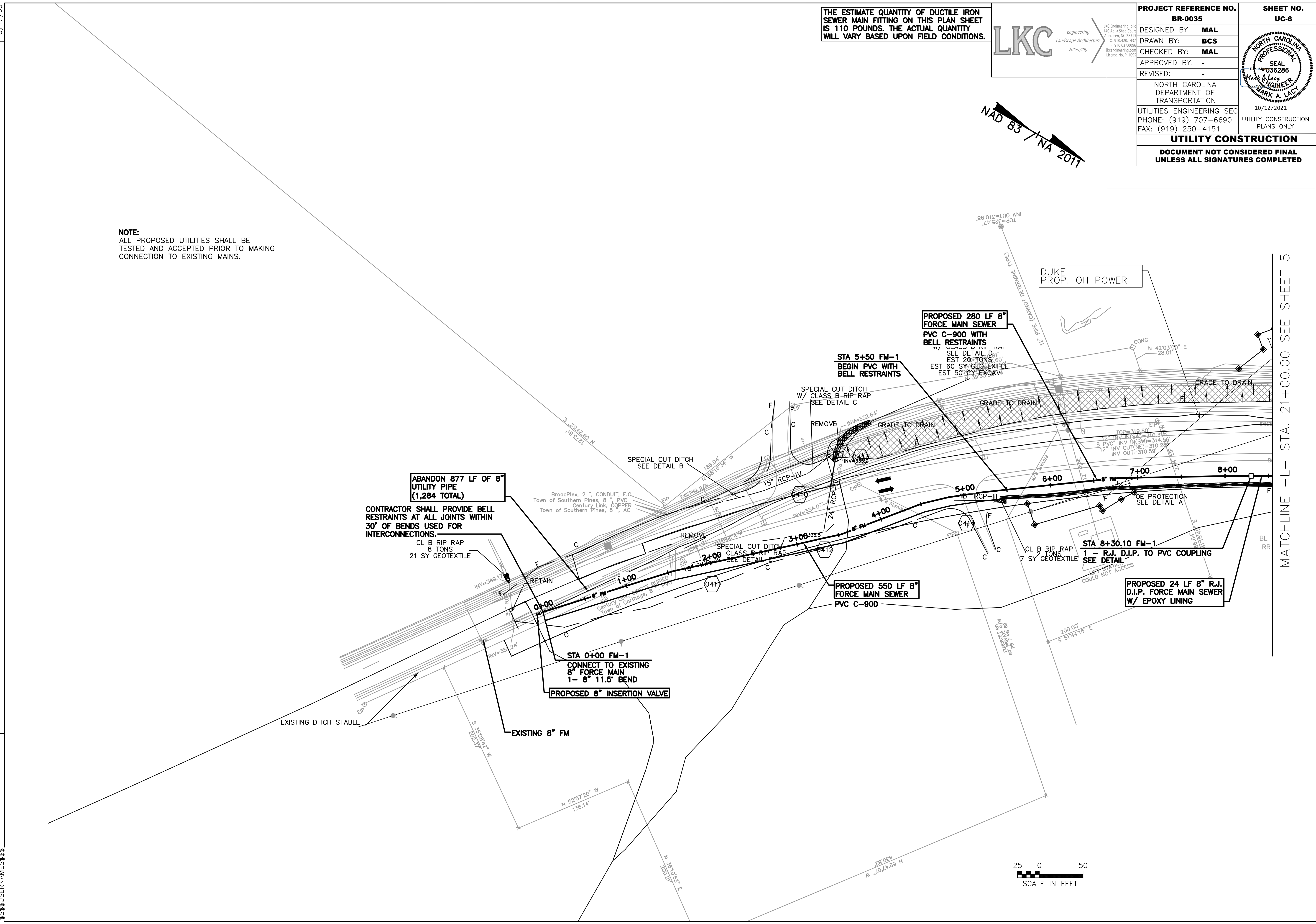

CONSTRUCTION
 CONTRACTOR'S NAME

PROJECT REFERENCE NO. BR-0035	SHEET NO. UC-8
DESIGNED BY: MAL	
DRAWN BY: BCS	
CHECKED BY: MAL	
APPROVED BY: -	
REVISED: -	
NORTH CAROLINA DEPARTMENT OF TRANSPORTATION	10/13/2021 UTILITY CONSTRUCTION PLANS ONLY
UTILITY CONSTRUCTION DOCUMENT NOT CONSIDERED FINAL UNLESS ALL SIGNATURES COMPLETED	

