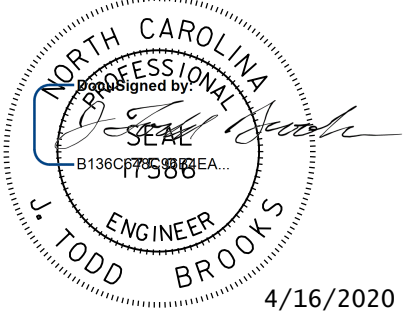

TIP NO. R-2233BB	SHEET NO. PMP-1
APPROVED: _____	
DATE: _____	
SEAL 	
DOCUMENT NOT CONSIDERED FINAL UNLESS ALL SIGNATURES COMPLETED	

STATE OF NORTH CAROLINA  
DEPARTMENT OF TRANSPORTATION

PAVEMENT MARKING PLAN  
RUTHERFORD COUNTY

T.I.P.: R-2233BB

CONTRACT: C204397

**INDEX**

SHEET NO.	DESCRIPTION
PMP-1	PAVEMENT MARKING PLAN TITLE SHEET
PMP-2	SCHEDULE SHEET
PMP-3-36	PAVEMENT MARKING DETAIL

**ROADWAY STANDARD DRAWING**

THE FOLLOWING ROADWAY STANDARDS AS APPEAR IN "ROADWAY STANDARD DRAWINGS" - N.C. DEPARTMENT OF TRANSPORTATION - RALEIGH, N.C., DATED JANUARY 2018 ARE APPLICABLE TO THIS PROJECT AND BY REFERENCE HEREBY ARE CONSIDERED A PART OF THESE PLANS:

STD. NO.	TITLE
1205.01	PAVEMENT MARKINGS - LINE TYPES AND OFFSETS
1205.02	PAVEMENT MARKINGS - TWO-LANE AND MULTILANE ROADWAYS
1205.03	PAVEMENT MARKINGS - EXIT AND ENTRANCE RAMP
1205.04	PAVEMENT MARKINGS - INTERSECTIONS
1205.05	PAVEMENT MARKINGS - TURN LANES
1205.07	PAVEMENT MARKINGS - PEDESTRIAN CROSSWALKS
1205.08	PAVEMENT MARKINGS - SYMBOLS AND WORD MESSAGES
1205.09	PAVEMENT MARKINGS - PAINTED ISLANDS
1205.10	PAVEMENT MARKINGS - SCHOOL AREAS
1205.12	PAVEMENT MARKINGS - BRIDGES
1205.13	PAVEMENT MARKINGS - LANE REDUCTIONS
1205.14	PAVEMENT MARKINGS - ROUNDABOUTS
1205.15	PAVEMENT MARKINGS - SUPERSTREETS
1250.01	RAISED PAVEMENT MARKERS - INSTALLATION SPACING
1251.01	RAISED PAVEMENT MARKERS - PERMANENT AND TEMPORARY
1253.01	RAISED PAVEMENT MARKERS - SNOWPLOWABLE
1261.01	GUARDRAIL AND BARRIER DELINEATORS - INSTALLATION SPACING
1261.02	GUARDRAIL AND BARRIER DELINEATORS - TYPES AND MOUNTING
1262.01	GUARDRAIL END DELINEATION
1264.01	OBJECT MARKERS - TYPES
1264.02	OBJECT MARKERS - INSTALLATION

**GENERAL NOTES**

THE FOLLOWING GENERAL NOTES APPLY AT ALL TIMES FOR THE DURATION OF THE CONSTRUCTION PROJECT, EXCEPT WHEN OTHERWISE NOTED IN THE PLAN, OR DIRECTED BY THE ENGINEER.

- A) INSTALL PAVEMENT MARKINGS AND PAVEMENT MARKERS ON THE FINAL SURFACE AS FOLLOWS:
 

ROAD NAME	MARKING	MARKER
ALL ROADS	POLYUREA	SNOWPLOWABLE
- B) TIE PROPOSED PAVEMENT MARKING LINES TO EXISTING PAVEMENT MARKING LINES.
- C) REMOVE/REPLACE ANY CONFLICTING/DAMAGED PAVEMENT MARKINGS AND MARKERS.
- D) PASSING ZONES WILL BE DETERMINED IN THE FIELD AND MUST BE APPROVED BY THE ENGINEER.
- E) REMOVE ALL RESIDUE AND SURFACE LAITANCE BY ACCEPTABLE METHODS ON CONCRETE BRIDGE DECKS PRIOR TO PLACING POLYUREA PAVEMENT MARKING MATERIAL.
- F) UNLESS OTHERWISE SPECIFIED, HEATED-IN-PLACE THERMOPLASTIC MAY BE USED IN LIEU OF EXTRUDED THERMOPLASTIC FOR STOP BARS, SYMBOLS, CHARACTERS AND DIAGONALS. IF HEATED-IN-PLACE IS USED, IT SHALL BE PAID FOR USING THE EXTRUDED THERMOPLASTIC PAY ITEM.
- G) UNLESS OTHERWISE SPECIFIED, HEATED-IN-PLACE THERMOPLASTIC MAY BE USED IN LIEU OF COLD APPLIED PLASTIC FOR STOP BARS, SYMBOLS, CHARACTERS AND DIAGONALS ON ASPHALT OR CONCRETE ROADWAYS. IF HEATED-IN-PLACE IS USED, IT SHALL BE PAID FOR USING THE COLD APPLIED PAY ITEM.

PLAN REVIEWED BY: N.C.D.O.T. SIGNING AND DELINEATION UNIT

KELVIN L. JORDAN SIGNING & DELINEATION REGIONAL ENGINEER

JOSE G. MARTINEZ, PE SIGNING & DELINEATION PROJECT DESIGN ENGINEER

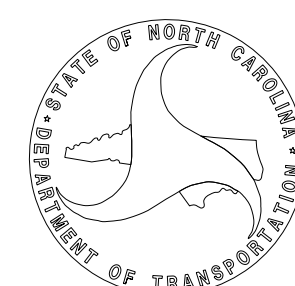

PLAN PREPARED BY:

J. TODD BROOKS, PE PROJECT ENGINEER

ABRAHAM WILES PROJECT DESIGN ENGINEER



2610 WYCLIFF ROAD  
SUITE 410  
RALEIGH, NC 27607  
PHONE: 919-881-9939  
NC COA No. F-0929

# PAVEMENT MARKING SCHEDULE

## PAVEMENT MARKING LINES

C20	WHITE EDGELINE	TYPE 4 REMOVABLE TAPE (6")
C30	YELLOW EDGELINE	TYPE 4 REMOVABLE TAPE (6")
P1	WHITE EDGELINE	PAINT (4")
P20	WHITE EDGELINE	PAINT (6")
P22	10 FT. WHITE SKIP	PAINT (6")
P23	3' - 9' SP WHITE MINISKIP	PAINT (6")
P30	YELLOW EDGELINE	PAINT (6")
P50	WHITE GORE LINE	PAINT (12")
T41	WHITE DIAGONAL	THERMOPLASTIC (8", 90 mils)
T42	YELLOW DIAGONAL	THERMOPLASTIC (8", 90 mils)
T46	WHITE CROSSWALK LINE	THERMOPLASTIC (8", 90 mils)
T61	WHITE STOPBAR	THERMOPLASTIC (24", 90 mils)
T62	WHITE CROSSWALK LINE	THERMOPLASTIC (24", 90 mils)
T103	24" YIELD LINE TRIANGLE	THERMOPLASTIC
V1	WHITE EDGELINE	POLYUREA (4", 20 mils)
V2	WHITE SOLID LANE LINE	POLYUREA (4", 20 mils)
V3	10 FT. WHITE SKIP	POLYUREA (4", 20 mils)
V4	3' - 9' SP WHITE MINISKIP	POLYUREA (4", 20 mils)
V5	2' - 6' SP WHITE MINISKIP	POLYUREA (4", 20 mils)
V10	YELLOW EDGELINE	POLYUREA (4", 20 mils)
V11	YELLOW SINGLE CENTER LINE	POLYUREA (4", 20 mils)
V12	10 FT. YELLOW SKIP	POLYUREA (4", 20 mils)
V13	YELLOW DOUBLE CENTER LINE	POLYUREA (4", 20 mils)
V20	WHITE EDGELINE	POLYUREA (6", 20 mils)
V21	WHITE SOLID LANE LINE	POLYUREA (6", 20 mils)
V22	10 FT. WHITE SKIP	POLYUREA (6", 20 mils)
V23	3' - 9' SP WHITE MINISKIP	POLYUREA (6", 20 mils)
V24	2' - 6' SP WHITE MINISKIP	POLYUREA (6", 20 mils)
V30	YELLOW EDGELINE	POLYUREA (6", 20 mils)
V33	YELLOW DOUBLE CENTER LINE	POLYUREA (6", 20 mils)
V34	2' - 6' SP YELLOW MINISKIP	POLYUREA (6", 20 mils)
V40	WHITE GORE LINE	POLYUREA (8", 20 mils)
V43	WHITE SOLID LANE LINE	POLYUREA (8", 20 mils)
V44	3' - 9' SP WHITE MINISKIP	POLYUREA (8", 20 mils)
V45	3' - 3' SP WHITE MINISKIP	POLYUREA (8", 20 mils)
V50	WHITE GORE LINE	POLYUREA (12", 20 mils)
V53	WHITE SOLID LANE LINE	POLYUREA (12", 20 mils)

## PAVEMENT MARKING SYMBOLS

C70	LEFT TURN ARROW	COLD APPLIED PLASTIC
P79	MERGE ARROW	PAINT
T70	LEFT TURN ARROW	THERMOPLASTIC
T71	RIGHT TURN ARROW	THERMOPLASTIC
T72	STRAIGHT ARROW	THERMOPLASTIC
T73	COMBO STRAIGHT / LEFT ARROW	THERMOPLASTIC
T74	COMBO STRAIGHT / RIGHT ARROW	THERMOPLASTIC
T77	U-TURN ARROW	THERMOPLASTIC
T79	MERGE ARROW	THERMOPLASTIC
T80	WRONG WAY RAMP ARROW	THERMOPLASTIC
T81	ELONGATED RAMP ARROW	THERMOPLASTIC
T100	ALPHANUMERIC CHARACTER	THERMOPLASTIC

## PAVEMENT MARKERS

MA	YELLOW AND YELLOW	PERMANENT RAISED
MB	CRYSTAL AND RED	PERMANENT RAISED
ME	YELLOW AND YELLOW	PERMANENT SNOWPLOWABLE
MF	CRYSTAL AND RED	PERMANENT SNOWPLOWABLE
MI	CRYSTAL AND RED	TEMPORARY RAISED

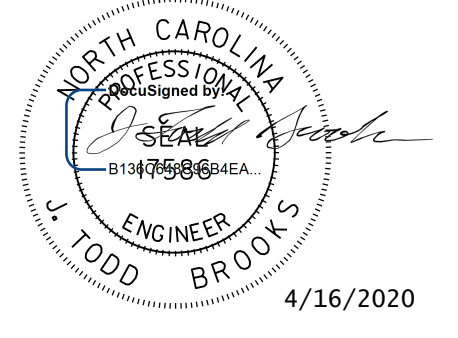
TIP NO.	SHEET NO.
R-2233BB	PMP-2
APPROVED:	_____
DATE:	_____
SEAL	
<b>DOCUMENT NOT CONSIDERED FINAL UNLESS ALL SIGNATURES COMPLETED</b>	

I6-APP-2020\_1041  
P:\50075420\CAD\Civil\N-2233BB\Tr-off\fig\PM\Plans\R2233BB\_PMP\_PMP\_2.dgn  
JTB  
4/16/2020



2610 WYCLIFF ROAD  
SUITE 410  
RALEIGH, NC 27607  
PHONE: 919-881-9939  
NC COA No. F-0929

# PAVEMENT MARKING SCHEDULE



TIP NO. R-2233BB	SHEET NO. PMP-3
APPROVED: _____	
DATE: _____	
SEAL	
<p>4/16/2020</p> <p><b>DOCUMENT NOT CONSIDERED FINAL UNLESS ALL SIGNATURES COMPLETED</b></p>	

**PAVEMENT MARKING SCHEDULE**

PAVEMENT MARKING LINES		
T61	WHITE STOPBAR	THERMOPLASTIC (24", 90 mils)
V1	WHITE EDGELINE	POLYUREA (4", 20 mils)
V2	WHITE SOLID LANE LINE	POLYUREA (4", 20 mils)
V3	10 FT. WHITE SKIP	POLYUREA (4", 20 mils)
V4	3' - 9" SP WHITE MINISKIP	POLYUREA (4", 20 mils)
V10	YELLOW EDGELINE	POLYUREA (4", 20 mils)
V13	YELLOW DOUBLE CENTER LINE	POLYUREA (4", 20 mils)
PAVEMENT MARKING SYMBOLS		
T70	LEFT TURN ARROW	THERMOPLASTIC
T71	RIGHT TURN ARROW	THERMOPLASTIC
PAVEMENT MARKERS		
ME	YELLOW AND YELLOW	PERMANENT SNOWPLOWABLE
MF	CRYSTAL AND RED	PERMANENT SNOWPLOWABLE

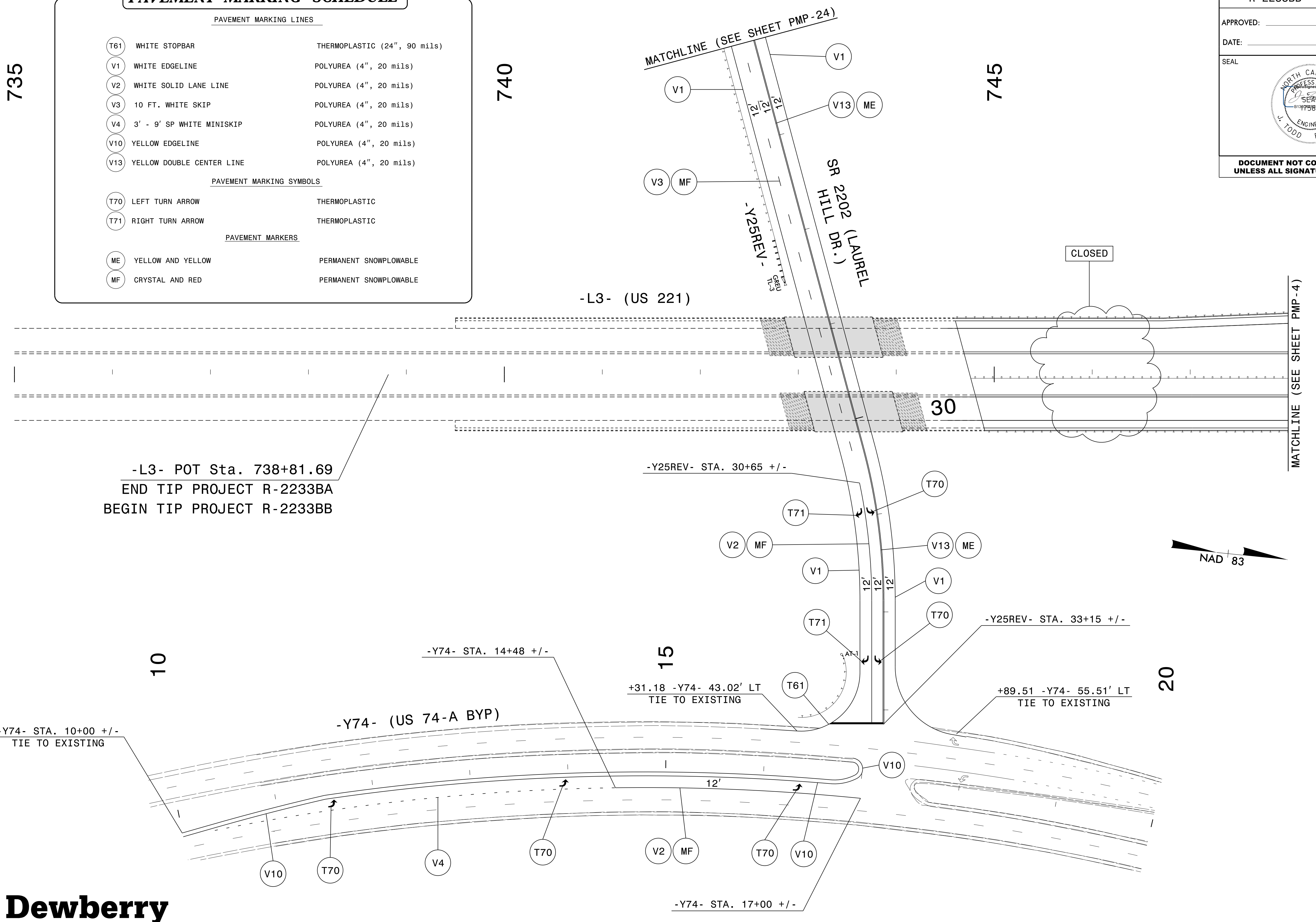

-L3- POT Sta. 738+81.69  
END TIP PROJECT R-2233BA  
BEGIN TIP PROJECT R-2233BB

+31.18 -Y74- 43.02' LT  
TIE TO EXISTING

+89.51 -Y74- 55.51' LT  
TIE TO EXISTING



2610 WYCLIFF ROAD  
SUITE 410  
RALEIGH, NC 27607  
PHONE: 919-881-9939  
NC COA No. F-0929

**PAVEMENT MARKING DETAIL**

I6-APP-2020\_10.dwg  
 P:\500715\20\CAD\Civil\N-2233BB\Tr of fig\PM\Plans\R2233BB\_PMP\_PMP\_3.dwg  
 JTB

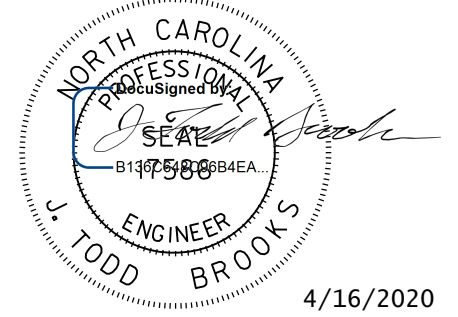
TIP NO. R-2233BB	SHEET NO. PMP-4
APPROVED: _____	
DATE: _____	
SEAL	
	
DOCUMENT NOT CONSIDERED FINAL UNLESS ALL SIGNATURES COMPLETED	

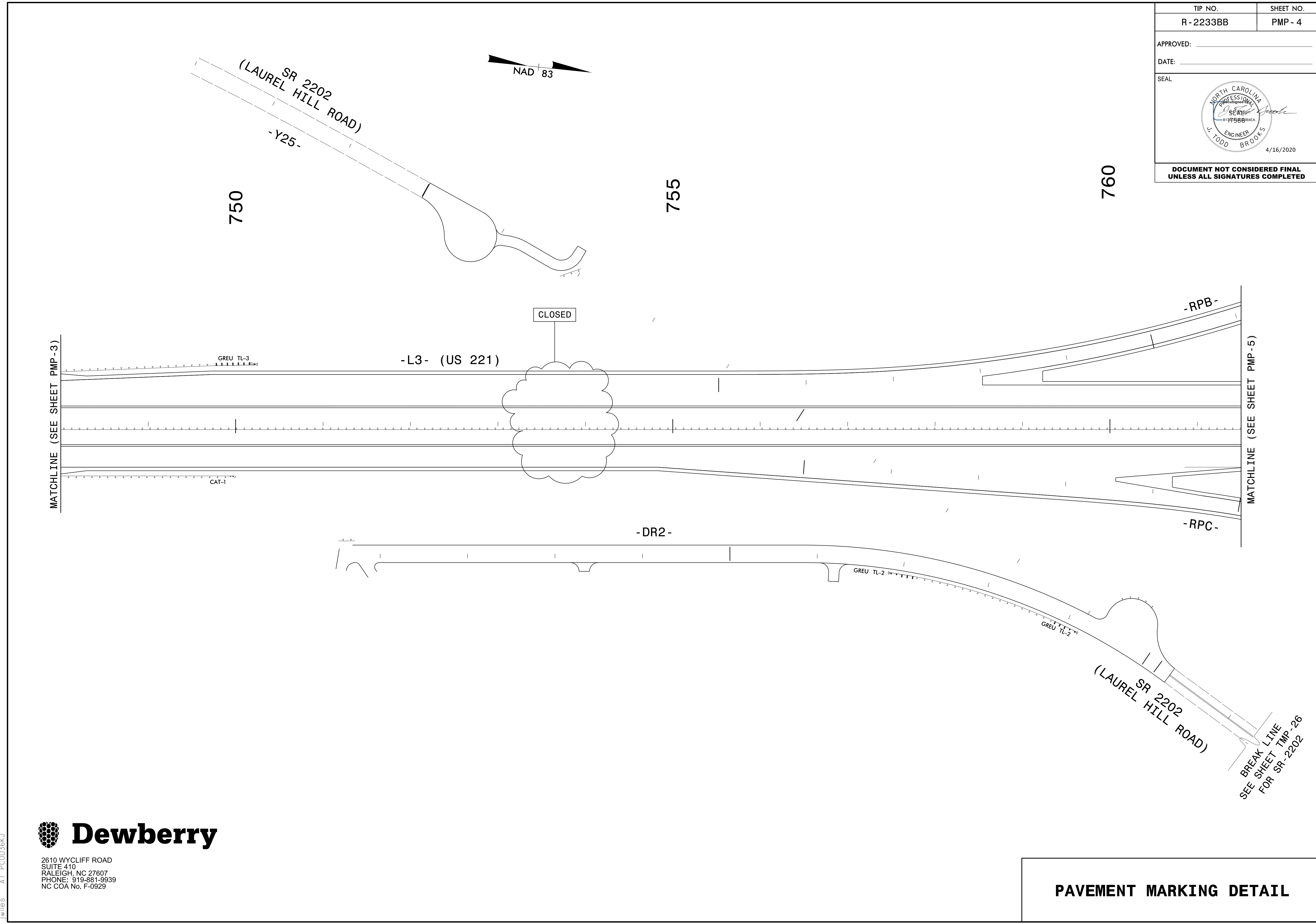

I6-APP-2020\_10.dwg  
P:\50075\20\CAD\CIVIL\N-2233BB\Tr of fig\PMP\Plans\R2233BB\_PMP\_PMP\_4.dgn  
JTB



**Dewberry**  
2610 WYCLIFF ROAD  
SUITE 410  
RALEIGH, NC 27607  
PHONE: 919-881-9939  
NC COA No. F-0929

**PAVEMENT MARKING DETAIL**

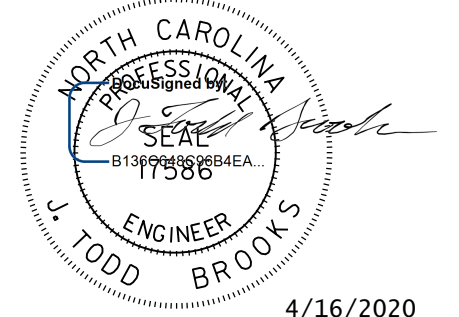

TIP NO. R-2233BB	SHEET NO. PMP-5
APPROVED: _____	
DATE: _____	
SEAL	
 J. TODD BROOKS ENGINEER 4/16/2020	
<b>DOCUMENT NOT CONSIDERED FINAL UNLESS ALL SIGNATURES COMPLETED</b>	

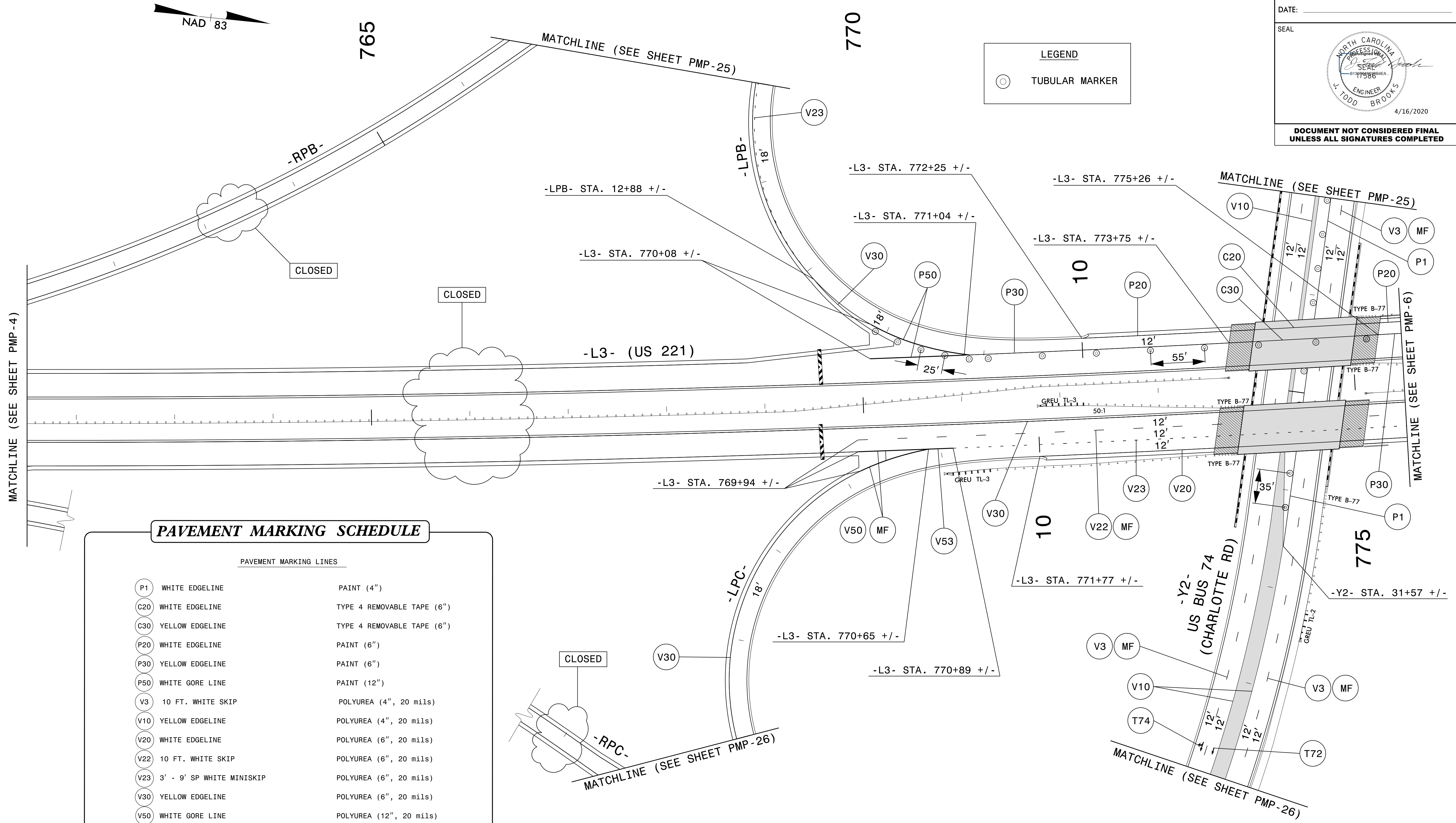

**PAVEMENT MARKING SCHEDULE**

PAVEMENT MARKING LINES	
P1	WHITE EDGELINE PAINT (4")
C20	WHITE EDGELINE TYPE 4 REMOVABLE TAPE (6")
C30	YELLOW EDGELINE TYPE 4 REMOVABLE TAPE (6")
P20	WHITE EDGELINE PAINT (6")
P30	YELLOW EDGELINE PAINT (6")
P50	WHITE GORE LINE PAINT (12")
V3	10 FT. WHITE SKIP POLYUREA (4", 20 mils)
V10	YELLOW EDGELINE POLYUREA (4", 20 mils)
V20	WHITE EDGELINE POLYUREA (6", 20 mils)
V22	10 FT. WHITE SKIP POLYUREA (6", 20 mils)
V23	3' - 9' SP WHITE MINISKIP POLYUREA (6", 20 mils)
V30	YELLOW EDGELINE POLYUREA (6", 20 mils)
V50	WHITE GORE LINE POLYUREA (12", 20 mils)
V53	WHITE SOLID LANE LINE POLYUREA (12", 20 mils)
PAVEMENT MARKING SYMBOLS	
T72	STRAIGHT ARROW THERMOPLASTIC
T74	COMBO STRAIGHT / RIGHT ARROW THERMOPLASTIC
PAVEMENT MARKERS	
MF	CRYSTAL AND RED PERMANENT SNOWFLOWABLE



2610 WYCLIFF ROAD  
SUITE 410  
RALEIGH, NC 27607  
PHONE: 919-881-9939  
NC COA No. F-0929

**PAVEMENT MARKING DETAIL**

I6-APP-2020\_10.dwg  
 P:\500715420\CAD\Civil\N-2233BB\Trg\fig\PM\Plans\R2233BB\_PMP\_PMP\_5.dgn  
 AT PC0036KJ

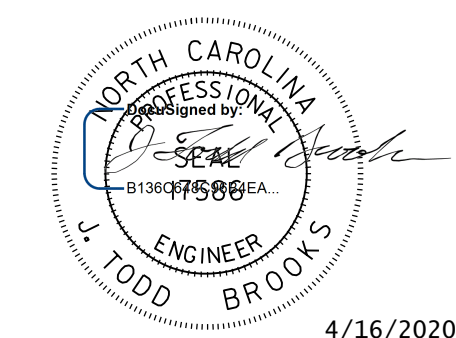
TIP NO. R-2233BB	SHEET NO. PMP-6
APPROVED: _____	
DATE: _____	
SEAL	
	
4/16/2020	
<b>DOCUMENT NOT CONSIDERED FINAL UNLESS ALL SIGNATURES COMPLETED</b>	

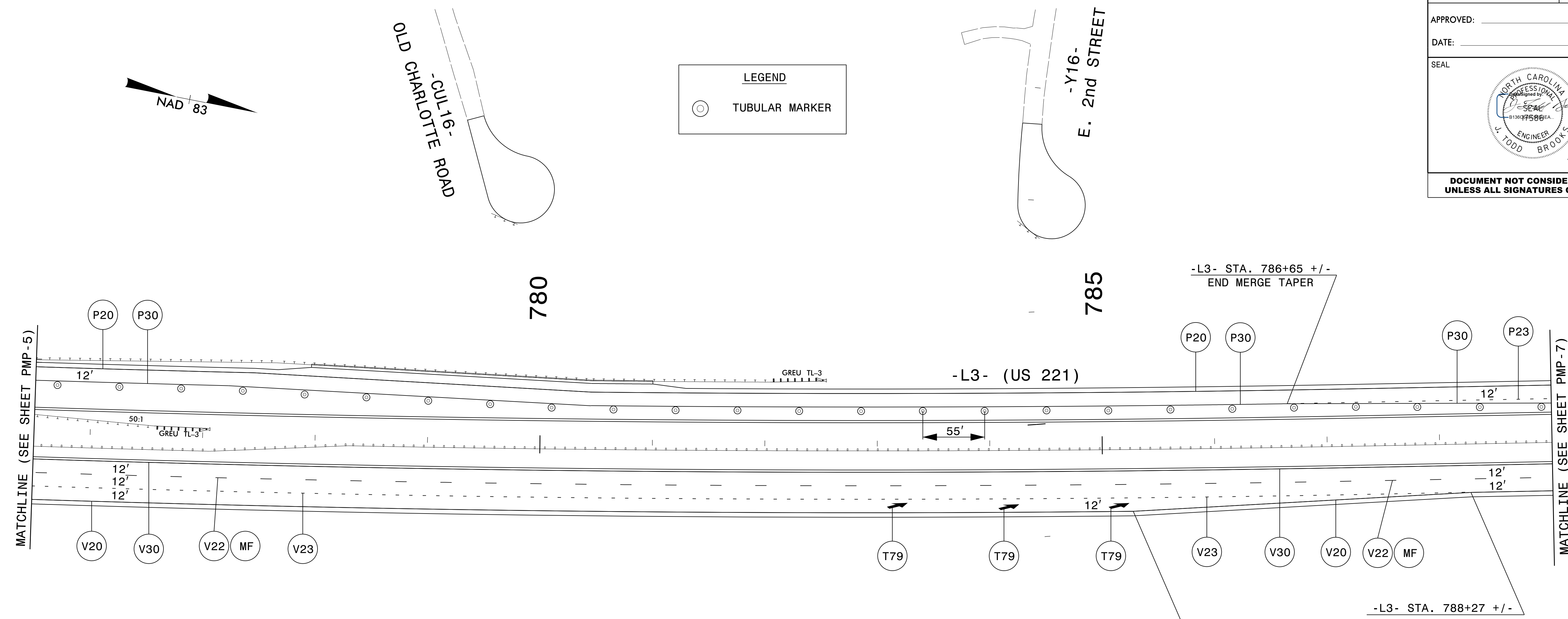

**PAVEMENT MARKING SCHEDULE**

PAVEMENT MARKING LINES

P20	WHITE EDGELINE	PAINT (6")
P23	3' - 9' SP WHITE MINISKIP	PAINT (6")
P30	YELLOW EDGELINE	PAINT (6")
V20	WHITE EDGELINE	POLYUREA (6", 20 mils)
V22	10 FT. WHITE SKIP	POLYUREA (6", 20 mils)
V23	3' - 9' SP WHITE MINISKIP	POLYUREA (6", 20 mils)
V30	YELLOW EDGELINE	POLYUREA (6", 20 mils)

PAVEMENT MARKING SYMBOLS

T79	MERGE ARROW	THERMOPLASTIC
-----	-------------	---------------

PAVEMENT MARKERS

MF	CRYSTAL AND RED	PERMANENT SNOWPLOWABLE
----	-----------------	------------------------

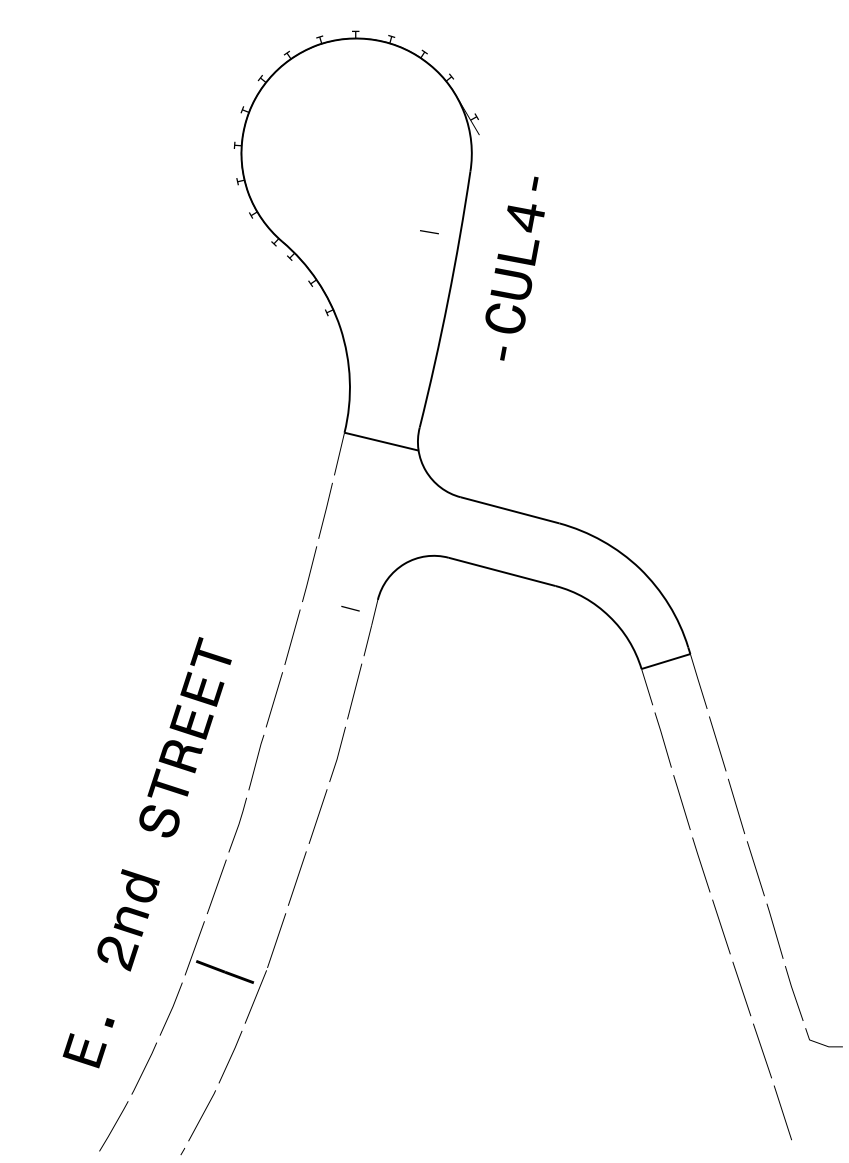

2610 WYCLIFF ROAD  
SUITE 410  
RALEIGH, NC 27607  
PHONE: 919-881-9939  
NC COA No. F-0929

**PAVEMENT MARKING DETAIL**

I6-APP-2020\_10.dwg  
 P:\50075\20\CAD\Civil\N-2233BB\Tr of fig\PM\Plans\R2233BB\_PMP\_PMP\_6.dgn  
 JTB



TIP NO. R-2233BB	SHEET NO. PMP-7
APPROVED: _____	
DATE: _____	
SEAL	
<b>DOCUMENT NOT CONSIDERED FINAL UNLESS ALL SIGNATURES COMPLETED</b>	

**LEGEND**

TUBULAR MARKER

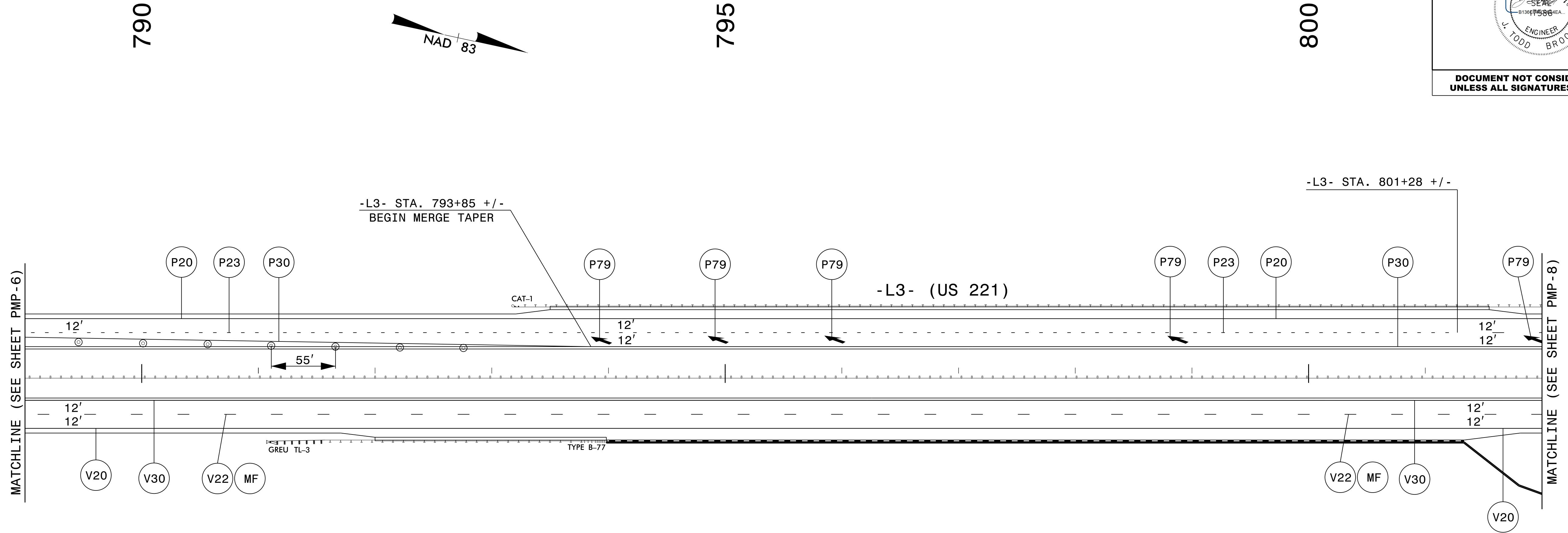

<b>PAVEMENT MARKING SCHEDULE</b>		
<u>PAVEMENT MARKING LINES</u>		
P20	WHITE EDGELINE	PAINT (6")
P23	3' - 9' SP WHITE MINISKIP	PAINT (6")
P30	YELLOW EDGELINE	PAINT (6")
V20	WHITE EDGELINE	POLYUREA (6", 20 mils)
V22	10 FT. WHITE SKIP	POLYUREA (6", 20 mils)
V30	YELLOW EDGELINE	POLYUREA (6", 20 mils)
<u>PAVEMENT MARKING SYMBOLS</u>		
P79	MERGE ARROW	PAINT
<u>PAVEMENT MARKERS</u>		
MF	CRYSTAL AND RED	PERMANENT SNOWPLOWABLE



2610 WYCLIFF ROAD  
SUITE 410  
RALEIGH, NC 27607  
PHONE: 919-881-9939  
NC COA No. F-0929

**PAVEMENT MARKING DETAIL**

I6-APP-2020\_10.dwg  
 P:\50075\20\CAD\Civil\N-2233BB\Tr of fig\PM\Plans\R2233BB\_PMP\_PMP\_7.dgn  
 JTB



TIP NO. R-2233BB	SHEET NO. PMP-8
APPROVED: _____	
DATE: _____	
SEAL	
<b>DOCUMENT NOT CONSIDERED FINAL UNLESS ALL SIGNATURES COMPLETED</b>	

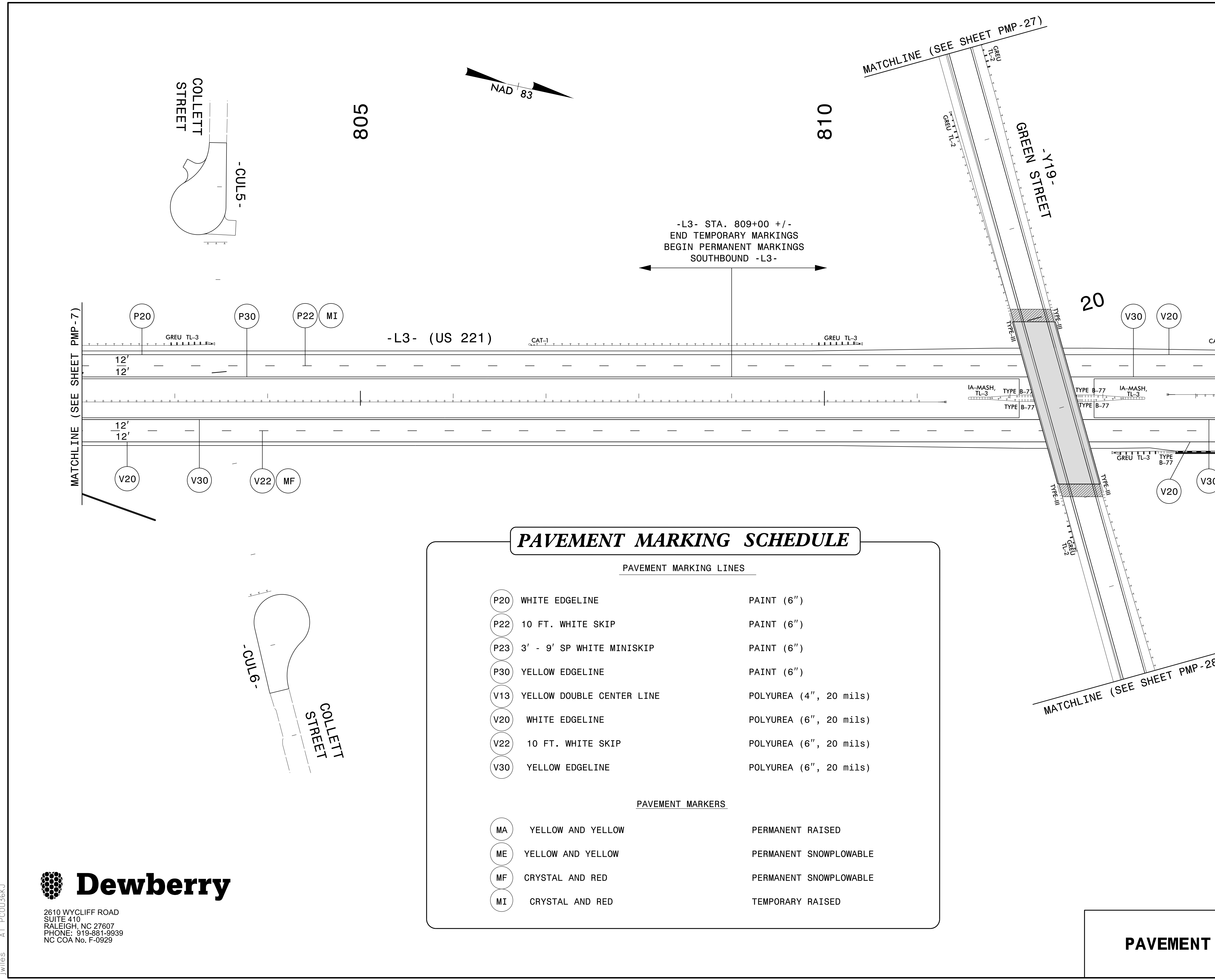

**PAVEMENT MARKING SCHEDULE**

PAVEMENT MARKING LINES

(P20)	WHITE EDGELINE	PAINT (6")
(P22)	10 FT. WHITE SKIP	PAINT (6")
(P23)	3' - 9' SP WHITE MINISKIP	PAINT (6")
(P30)	YELLOW EDGELINE	PAINT (6")
(V13)	YELLOW DOUBLE CENTER LINE	POLYUREA (4", 20 mils)
(V20)	WHITE EDGELINE	POLYUREA (6", 20 mils)
(V22)	10 FT. WHITE SKIP	POLYUREA (6", 20 mils)
(V30)	YELLOW EDGELINE	POLYUREA (6", 20 mils)

PAVEMENT MARKERS

(MA)	YELLOW AND YELLOW	PERMANENT RAISED
(ME)	YELLOW AND YELLOW	PERMANENT SNOWPLOWABLE
(MF)	CRYSTAL AND RED	PERMANENT SNOWPLOWABLE
(MI)	CRYSTAL AND RED	TEMPORARY RAISED

**PAVEMENT MARKING DETAIL**

I6-APP-2020\_10.dwg  
 P:\50075420\CAD\CIVIL\N-2233BB\Tr of fig\PM\Plans\R2233BB\_PMP\_PMP\_8.dgn  
 JTB  
 AT PC0036KJ

2610 WYCLIFF ROAD  
 SUITE 410  
 RALEIGH, NC 27607  
 PHONE: 919-881-9939  
 NC COA No. F-0929

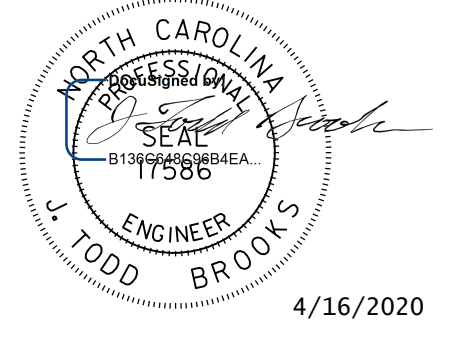
TIP NO. R-2233BB	SHEET NO. PMP-9
APPROVED: _____	
DATE: _____	
SEAL  4/16/2020	
DOCUMENT NOT CONSIDERED FINAL UNLESS ALL SIGNATURES COMPLETED	

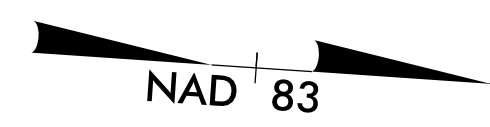

### PAVEMENT MARKING SCHEDULE

PAVEMENT MARKING LINES		
V20	WHITE EDGELINE	POLYUREA (6", 20 mils)
V22	10 FT. WHITE SKIP	POLYUREA (6", 20 mils)
V30	YELLOW EDGELINE	POLYUREA (6", 20 mils)
PAVEMENT MARKERS		
MF	CRYSTAL AND RED	PERMANENT SNOWPLOWABLE

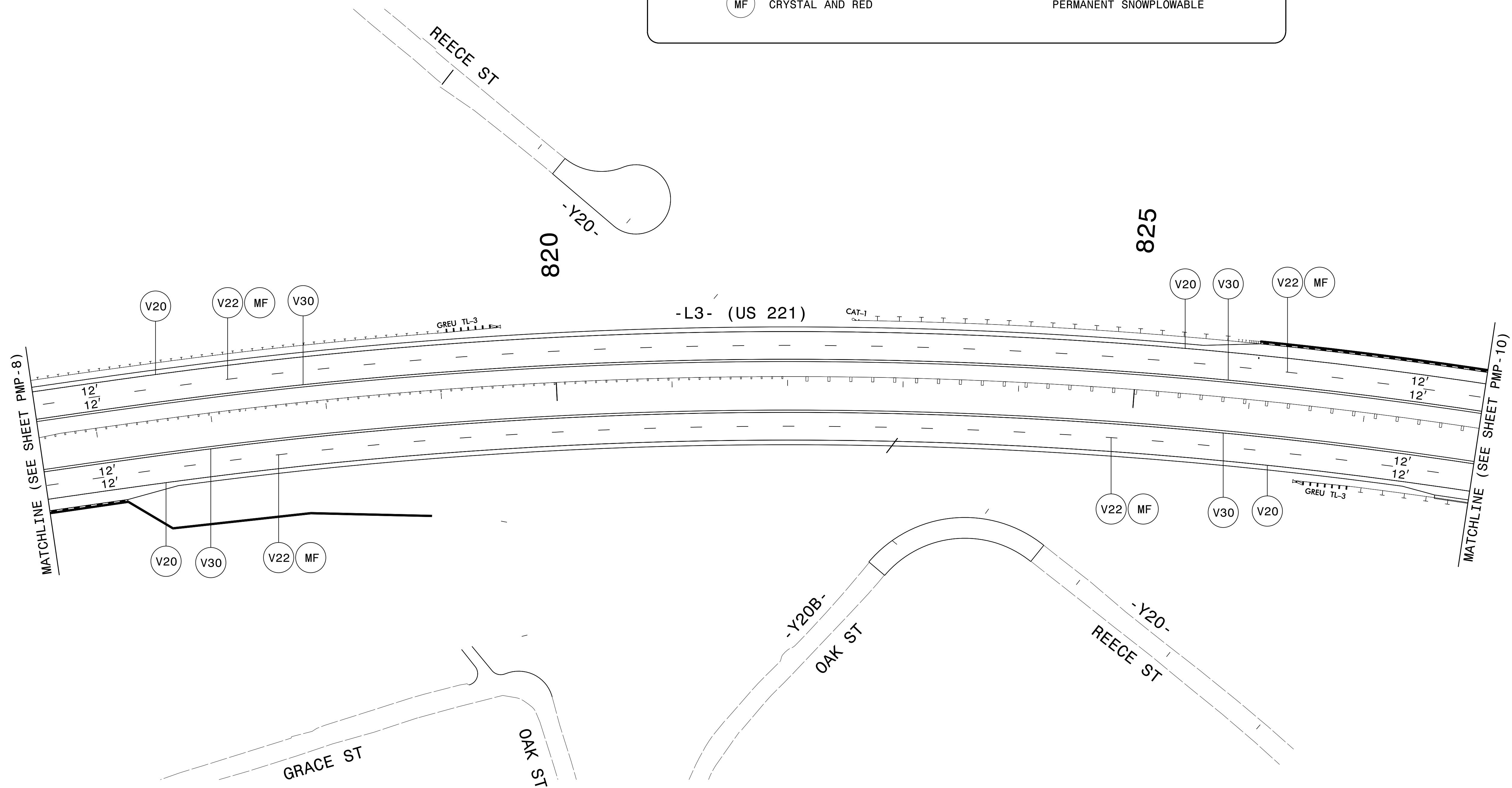

I6-APP-2020\_10.dwg  
 P:\50075\20\CAD\Civil\N-2233BB\Tr of fic\PM\Plans\R2233BB\_PMP\_PMP\_9.dgn  
 JTB  
 AT PC0036KJ



**Dewberry**  
 2610 WYCLIFF ROAD  
 SUITE 410  
 RALEIGH, NC 27607  
 PHONE: 919-881-9939  
 NC COA No. F-0929

**PAVEMENT MARKING DETAIL**

APPROVED: \_\_\_\_\_

DATE: \_\_\_\_\_

SEAL

4/16/2020

**DOCUMENT NOT CONSIDERED FINAL UNLESS ALL SIGNATURES COMPLETED**

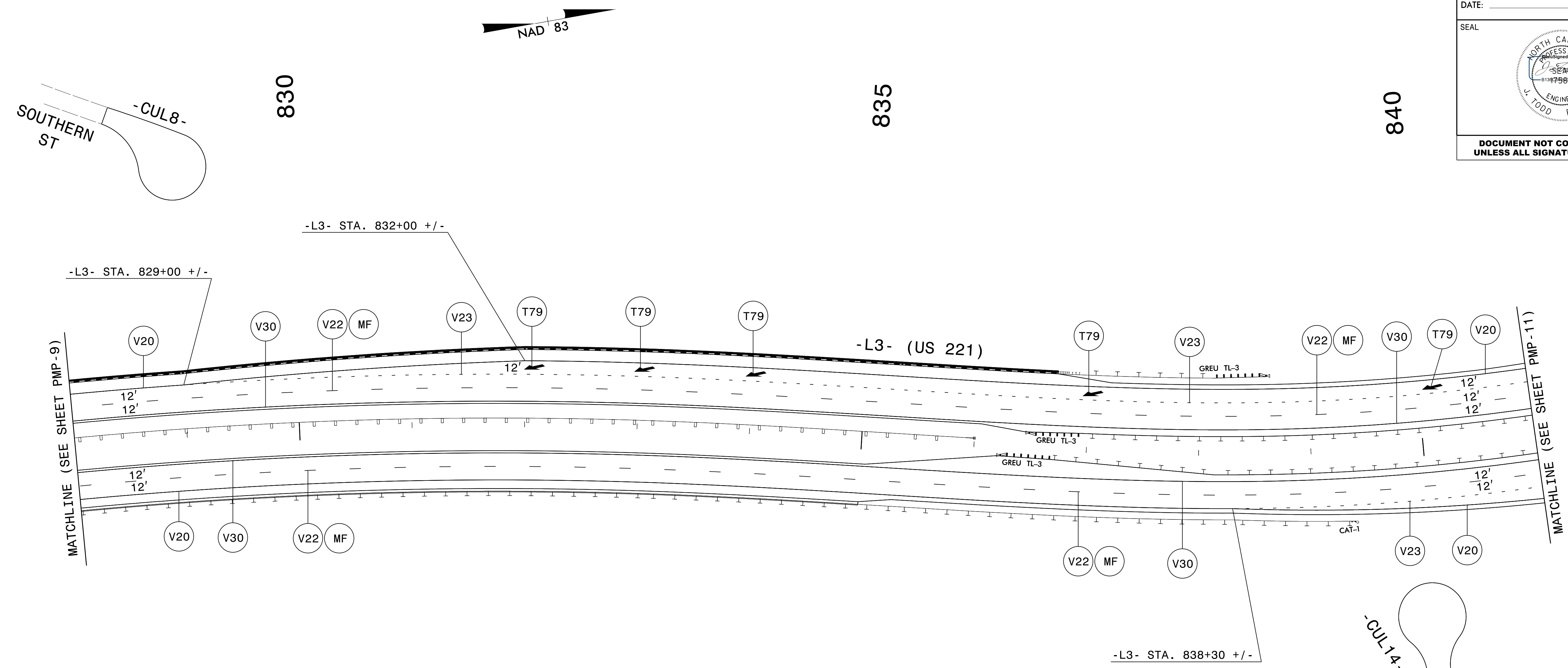

### PAVEMENT MARKING SCHEDULE

#### PAVEMENT MARKING LINES

- |     |                           |                        |
|-----|---------------------------|------------------------|
| V20 | WHITE EDGELINE            | POLYUREA (6", 20 mils) |
| V22 | 10 FT. WHITE SKIP         | POLYUREA (6", 20 mils) |
| V23 | 3' - 9' SP WHITE MINISKIP | POLYUREA (6", 20 mils) |
| V30 | YELLOW EDGELINE           | POLYUREA (6", 20 mils) |

#### PAVEMENT MARKING SYMBOLS

- |     |             |               |
|-----|-------------|---------------|
| T79 | MERGE ARROW | THERMOPLASTIC |
|-----|-------------|---------------|

#### PAVEMENT MARKERS

- |    |                 |                        |
|----|-----------------|------------------------|
| MF | CRYSTAL AND RED | PERMANENT SNOWPLOWABLE |
|----|-----------------|------------------------|



2610 WYCLIFF ROAD  
SUITE 410  
RALEIGH, NC 27607  
PHONE: 919-881-9939  
NC COA No. F-0929

I6-APP-2020\_10.dwg  
 P:\50075420\CAD\Civil\N-2233BB\Tr of fic\PM\Plans\R2233BB\_PMP\_PMP\_10.dgn  
 JTB  
 PC0036KJ

## PAVEMENT MARKING DETAIL

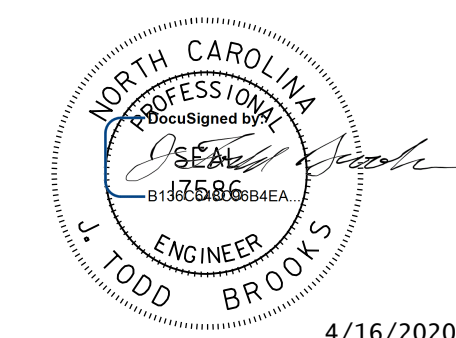

TIP NO. R-2233BB	SHEET NO. PMP-11
APPROVED: _____	
DATE: _____	
SEAL	
	
4/16/2020	
<b>DOCUMENT NOT CONSIDERED FINAL UNLESS ALL SIGNATURES COMPLETED</b>	

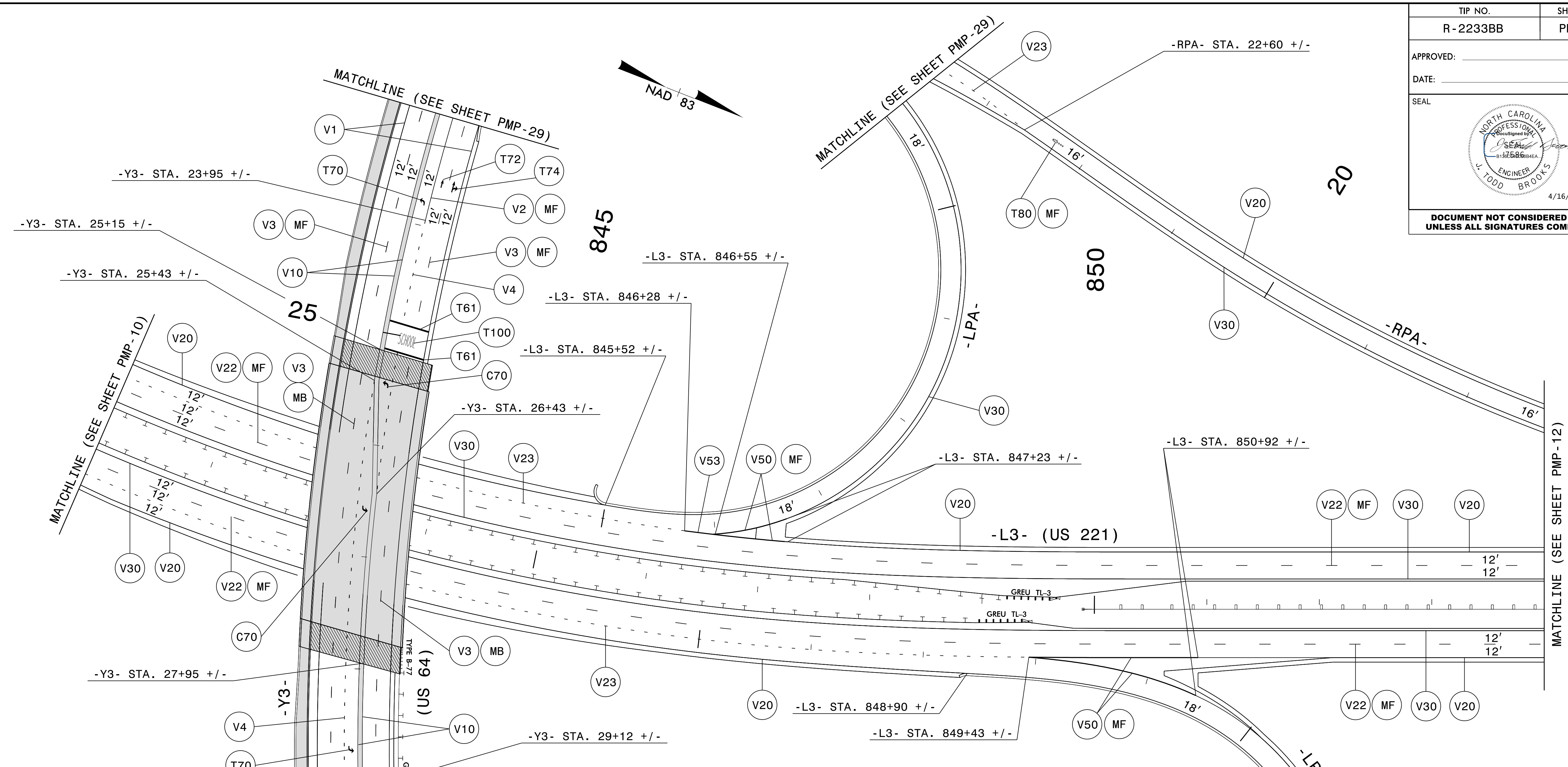

PAVEMENT MARKING SCHEDULE	
PAVEMENT MARKING LINES	
(T61) WHITE STOPBAR	THERMOPLASTIC (24", 90 mils)
(V1) WHITE EDGELINE	POLYUREA (4", 20 mils)
(V2) WHITE SOLID LANE LINE	POLYUREA (4", 20 mils)
(V3) 10 FT. WHITE SKIP	POLYUREA (4", 20 mils)
(V4) 3' - 9" SP WHITE MINISKIP	POLYUREA (4", 20 mils)
(V10) YELLOW EDGELINE	POLYUREA (4", 20 mils)
(V20) WHITE EDGELINE	POLYUREA (6", 20 mils)
(V22) 10 FT. WHITE SKIP	POLYUREA (6", 20 mils)
(V23) 3' - 9" SP WHITE MINISKIP	POLYUREA (6", 20 mils)
(V30) YELLOW EDGELINE	POLYUREA (6", 20 mils)
(V50) WHITE GORE LINE	POLYUREA (12", 20 mils)
(V53) WHITE SOLID LANE LINE	POLYUREA (12", 20 mils)
PAVEMENT MARKING SYMBOLS	
(C70) LEFT TURN ARROW	TYPE 1 - COLD APPLIED PLASTIC
(T70) LEFT TURN ARROW	THERMOPLASTIC
(T72) STRAIGHT ARROW	THERMOPLASTIC
(T74) COMBO STRAIGHT / RIGHT ARROW	THERMOPLASTIC
(T80) RAMP ARROW MARKER	THERMOPLASTIC
(T100) ALPHANUMERIC CHARACTER	THERMOPLASTIC
PAVEMENT MARKERS	
(MB) CRYSTAL AND RED	PERMANENT RAISED
(MF) CRYSTAL AND RED	PERMANENT SNOWPLOWABLE

**PAVEMENT MARKING DETAIL**

I6-APP-2020\_I041  
 P:\50075\20\CAD\CIVIL\N-2233BB\Trg\fig\PM\Plans\2233BB\_PMP\_PMP\_IL.dgn  
 JTB  
 AT PC0036KJ

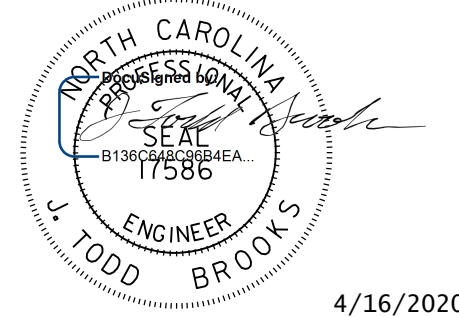

2610 WYCLIFF ROAD  
 SUITE 410  
 RALEIGH, NC 27607  
 PHONE: 919-881-9939  
 NC COA No. F-0929

TIP NO. R-2233BB	SHEET NO. PMP-12
APPROVED: _____	
DATE: _____	
SEAL  4/16/2020 <b>DOCUMENT NOT CONSIDERED FINAL UNLESS ALL SIGNATURES COMPLETED</b>	

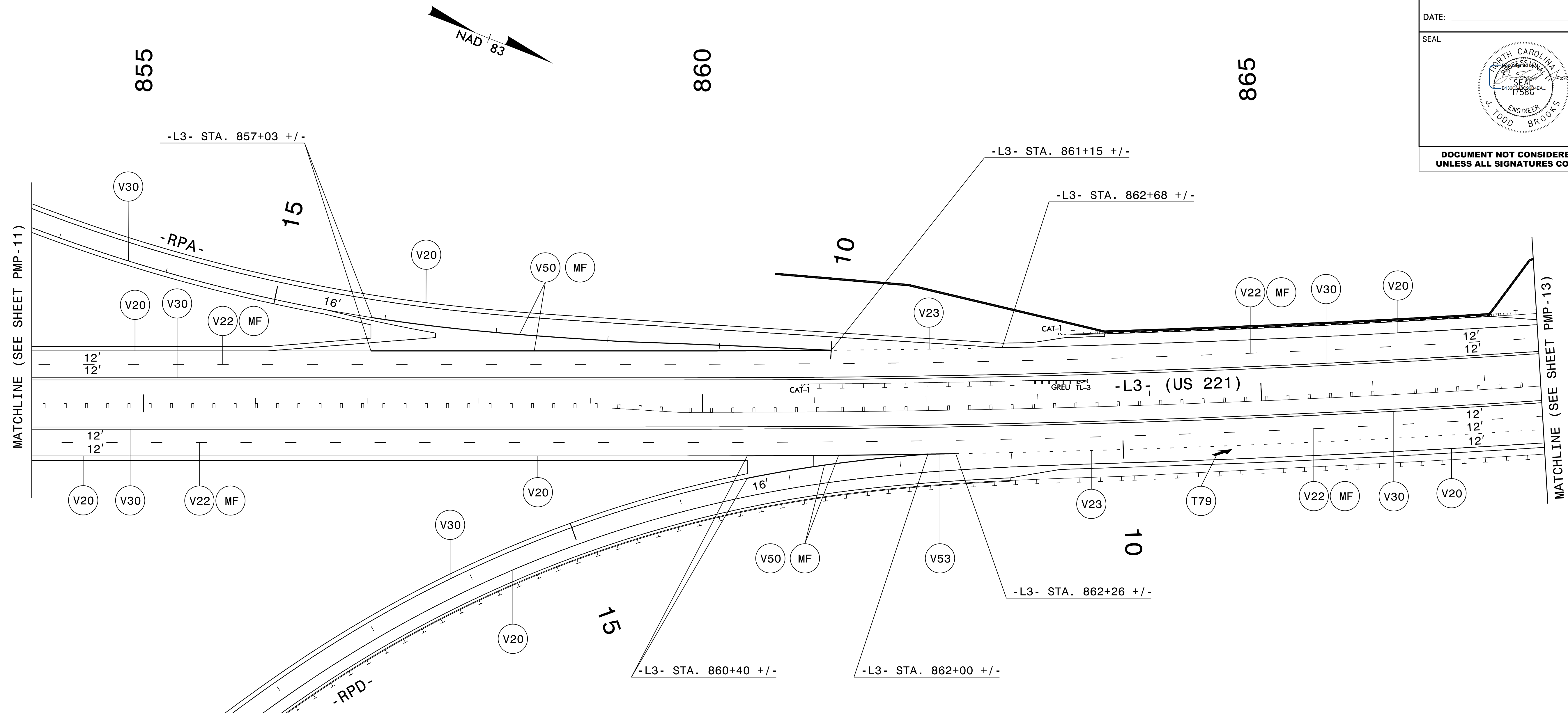

**PAVEMENT MARKING SCHEDULE**

PAVEMENT MARKING LINES	
V20	WHITE EDGELINE POLYUREA (6", 20 mils)
V22	10 FT. WHITE SKIP POLYUREA (6", 20 mils)
V23	3' - 9' SP WHITE MINISKIP POLYUREA (6", 20 mils)
V30	YELLOW EDGELINE POLYUREA (6", 20 mils)
V50	WHITE GORE LINE POLYUREA (12", 20 mils)
V53	WHITE SOLID LANE LINE POLYUREA (12", 20 mils)
PAVEMENT MARKING SYMBOLS	
T79	MERGE ARROW THERMOPLASTIC
PAVEMENT MARKERS	
MF	CRYSTAL AND RED PERMANENT SNOWPLOWABLE

**PAVEMENT MARKING DETAIL**

I6-APP-2020\_10.dwg  
 P:\50075420\CAD\CIVIL\N-2233BB\Tr of fig\PMP\Plans\R2233BB\_PMP\_PMP\_12.dgn  
 JTB  
 4/16/2020



**Dewberry**  
 2610 WYCLIFF ROAD  
 SUITE 410  
 RALEIGH, NC 27607  
 PHONE: 919-881-9939  
 NC COA No. F-0929



TIP NO. R-2233BB	SHEET NO. PMP-13
APPROVED: _____	
DATE: _____	
SEAL	
4/16/2020	
<b>DOCUMENT NOT CONSIDERED FINAL UNLESS ALL SIGNATURES COMPLETED</b>	

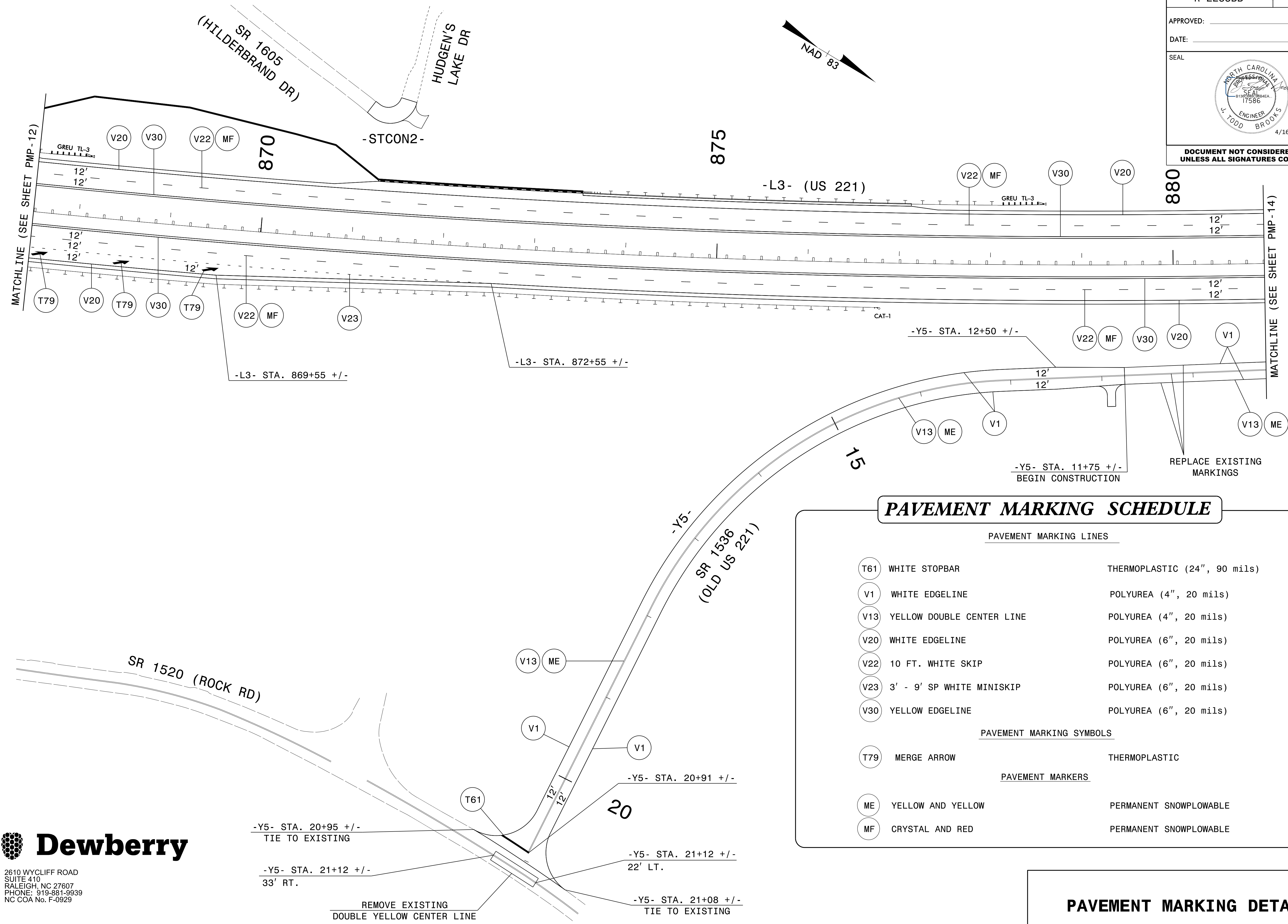

**PAVEMENT MARKING SCHEDULE**

PAVEMENT MARKING LINES		
T61	WHITE STOPBAR	THERMOPLASTIC (24", 90 mils)
V1	WHITE EDGELINE	POLYUREA (4", 20 mils)
V13	YELLOW DOUBLE CENTER LINE	POLYUREA (4", 20 mils)
V20	WHITE EDGELINE	POLYUREA (6", 20 mils)
V22	10 FT. WHITE SKIP	POLYUREA (6", 20 mils)
V23	3' - 9' SP WHITE MINISKIP	POLYUREA (6", 20 mils)
V30	YELLOW EDGELINE	POLYUREA (6", 20 mils)
PAVEMENT MARKING SYMBOLS		
T79	MERGE ARROW	THERMOPLASTIC
PAVEMENT MARKERS		
ME	YELLOW AND YELLOW	PERMANENT SNOWPLOWABLE
MF	CRYSTAL AND RED	PERMANENT SNOWPLOWABLE

**PAVEMENT MARKING DETAIL**

2610 WYCLIFF ROAD  
SUITE 410  
RALEIGH, NC 27607  
PHONE: 919-881-9939  
NC COA No. F-0929

I6-APP-2020\_10.dwg  
 P:\50015\20\CAD\CIVIL\N-2233BB\Tr\of\ic\pmp\Plans\R2233BB\_PMP\_PMP\_13.dwg  
 JTB  
 AT PC0036KJ



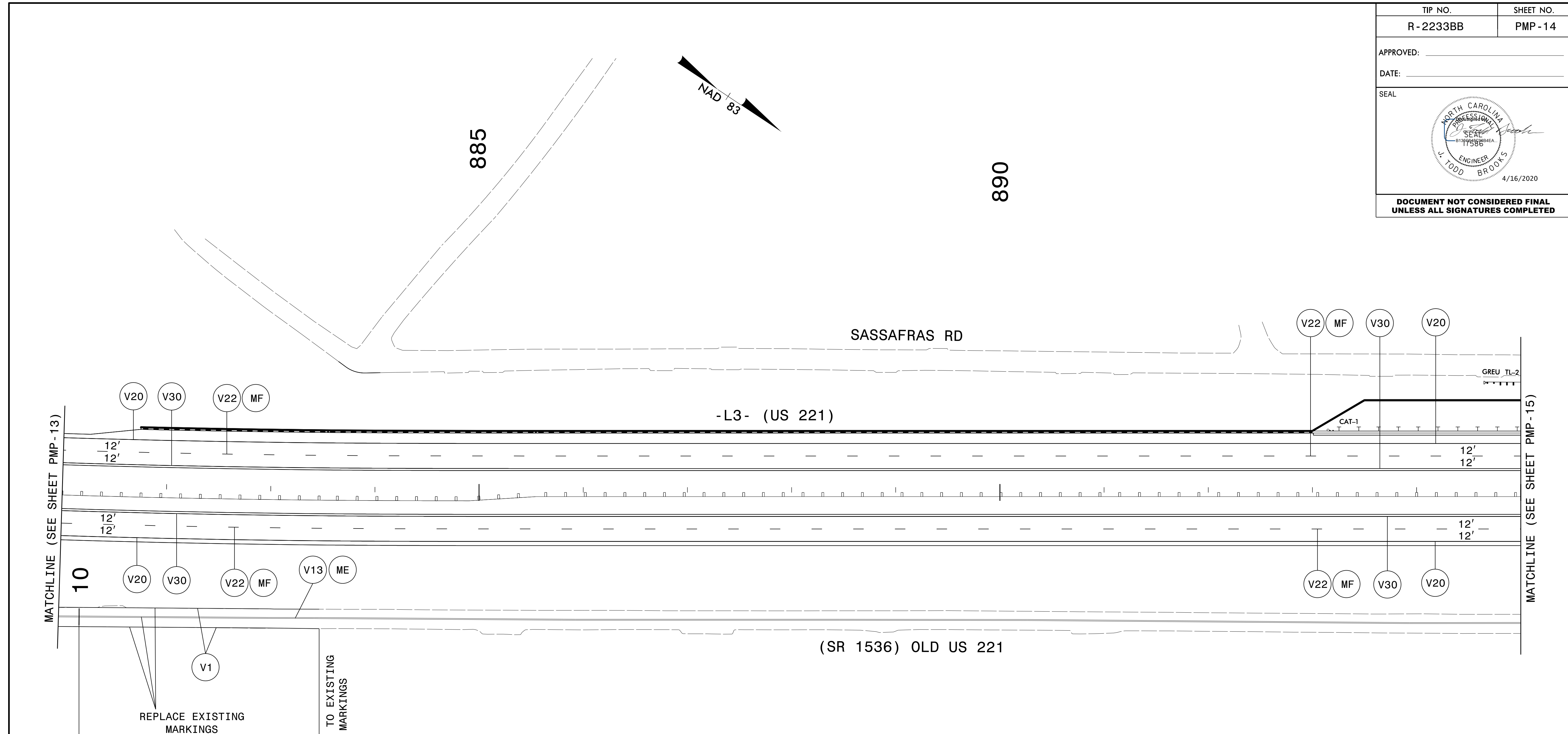

**PAVEMENT MARKING SCHEDULE**

PAVEMENT MARKING LINES

- |     |                           |                        |
|-----|---------------------------|------------------------|
| V1  | WHITE EDGELINE            | POLYUREA (4", 20 mils) |
| V13 | YELLOW DOUBLE CENTER LINE | POLYUREA (4", 20 mils) |
| V20 | WHITE EDGELINE            | POLYUREA (6", 20 mils) |
| V22 | 10 FT. WHITE SKIP         | POLYUREA (6", 20 mils) |
| V30 | YELLOW EDGELINE           | POLYUREA (6", 20 mils) |

PAVEMENT MARKERS

- |    |                   |                        |
|----|-------------------|------------------------|
| ME | YELLOW AND YELLOW | PERMANENT SNOWPLOWABLE |
| MF | CRYSTAL AND RED   | PERMANENT SNOWPLOWABLE |

**PAVEMENT MARKING DETAIL**

I6-APP-2020\_10.dwg  
 P:\50075420\CAD\Civil\N-2233BB\Tr of fig\PMP\Plans\R2233BB\_PMP\_PMP\_14.dgn  
 JTB  
 AT PC0036KJ

2610 WYCLIFF ROAD  
 SUITE 410  
 RALEIGH, NC 27607  
 PHONE: 919-881-9939  
 NC COA No. F-0929

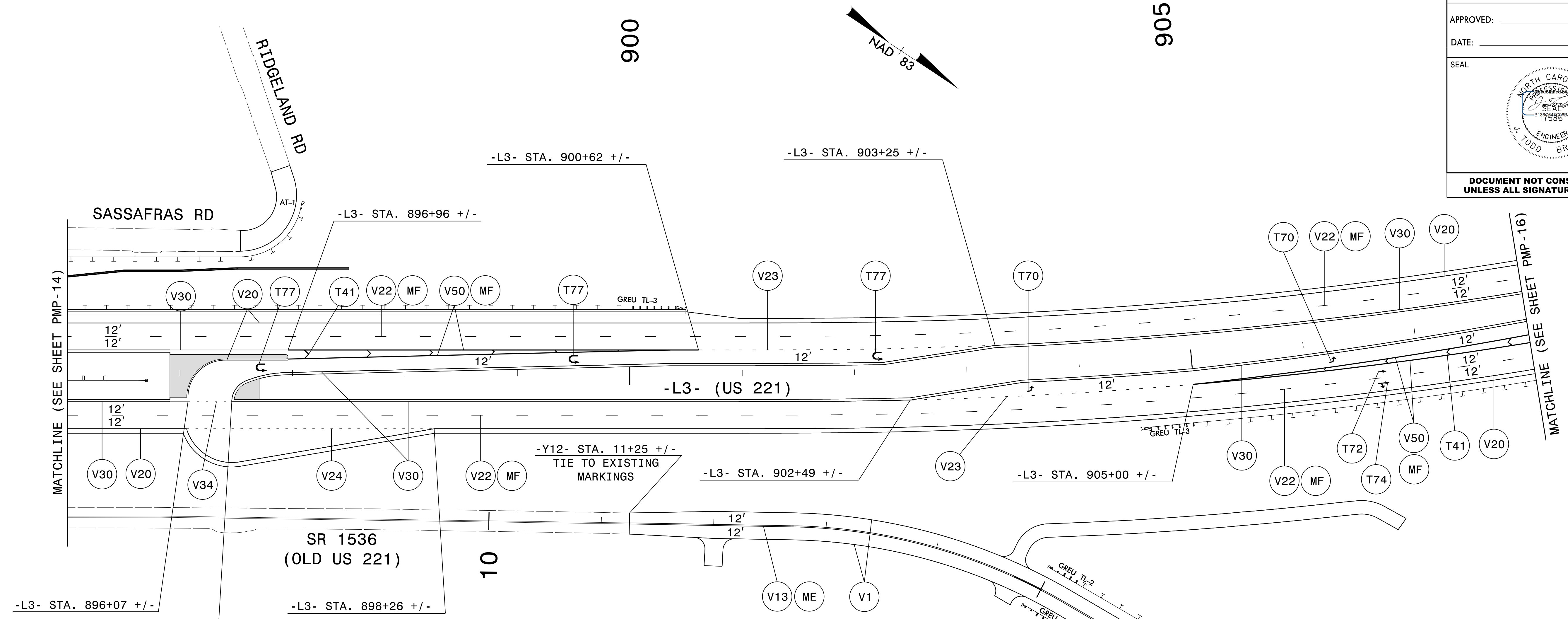

**PAVEMENT MARKING SCHEDULE**

PAVEMENT MARKING LINES

(T41)	WHITE DIAGONAL	THERMOPLASTIC (8", 90 mils)
(V1)	WHITE EDGELINE	POLYUREA (4", 20 mils)
(V13)	YELLOW DOUBLE CENTER LINE	POLYUREA (4", 20 mils)
(V20)	WHITE EDGELINE	POLYUREA (6", 20 mils)
(V22)	10 FT. WHITE SKIP	POLYUREA (6", 20 mils)
(V23)	3' - 9' SP WHITE MINISKIP	POLYUREA (6", 20 mils)
(V24)	2' - 6' SP WHITE MINISKIP	POLYUREA (6", 20 mils)
(V30)	YELLOW EDGELINE	POLYUREA (6", 20 mils)
(V34)	2' - 6' SP YELLOW MINISKIP	POLYUREA (6", 20 mils)
(V50)	WHITE GORE LINE	POLYUREA (12", 20 mils)

PAVEMENT MARKING SYMBOLS

(T70)	LEFT TURN ARROW	THERMOPLASTIC
(T72)	STRAIGHT ARROW	THERMOPLASTIC
(T74)	COMBO STRAIGHT / RIGHT ARROW	THERMOPLASTIC
(T77)	U-TURN ARROW	THERMOPLASTIC

PAVEMENT MARKERS

(ME)	YELLOW AND YELLOW	PERMANENT SNOWPLOWABLE
(MF)	CRYSTAL AND RED	PERMANENT SNOWPLOWABLE

**PAVEMENT MARKING DETAIL**

I6-APP-2020\_I04I  
 P:\50071520\CAD\CIVIL\NR-2233BB\Tr of fic\PM\Plans\R2233BB\_PMP\_PMP\_15.dgn  
 JTB  
 AT PC0036KJ



**Dewberry**  
 2610 WYCLIFF ROAD  
 SUITE 410  
 RALEIGH, NC 27607  
 PHONE: 919-881-9939  
 NC COA No. F-0929

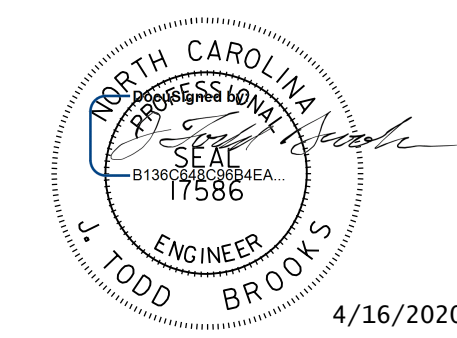

TIP NO. R-2233BB	SHEET NO. PMP-16
APPROVED: _____	
DATE: _____	
SEAL	
	
4/16/2020	
<b>DOCUMENT NOT CONSIDERED FINAL UNLESS ALL SIGNATURES COMPLETED</b>	

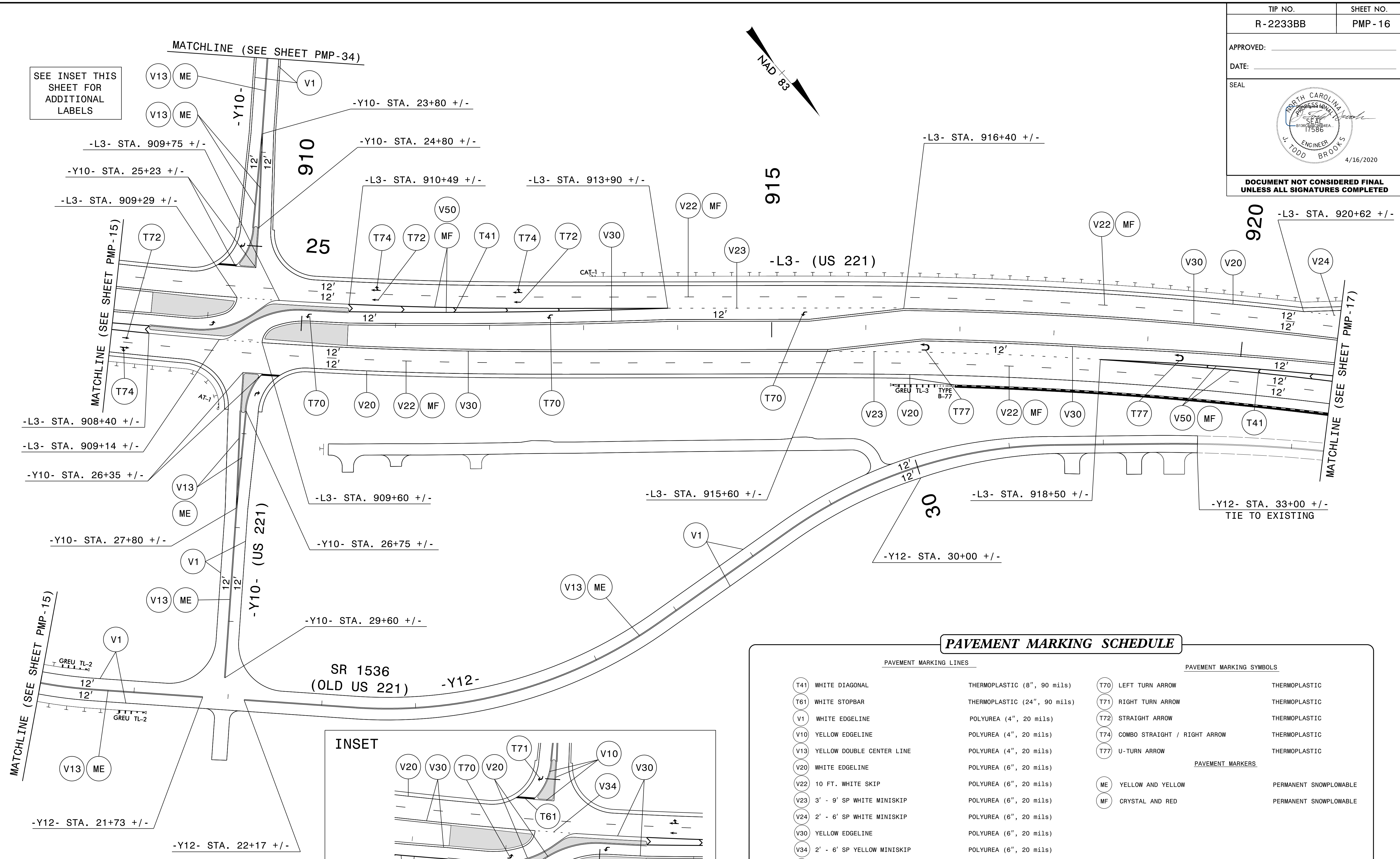

SEE INSET THIS SHEET FOR ADDITIONAL LABELS

MATCHLINE (SEE SHEET PMP-15)

MATCHLINE (SEE SHEET PMP-15)

MATCHLINE (SEE SHEET PMP-17)

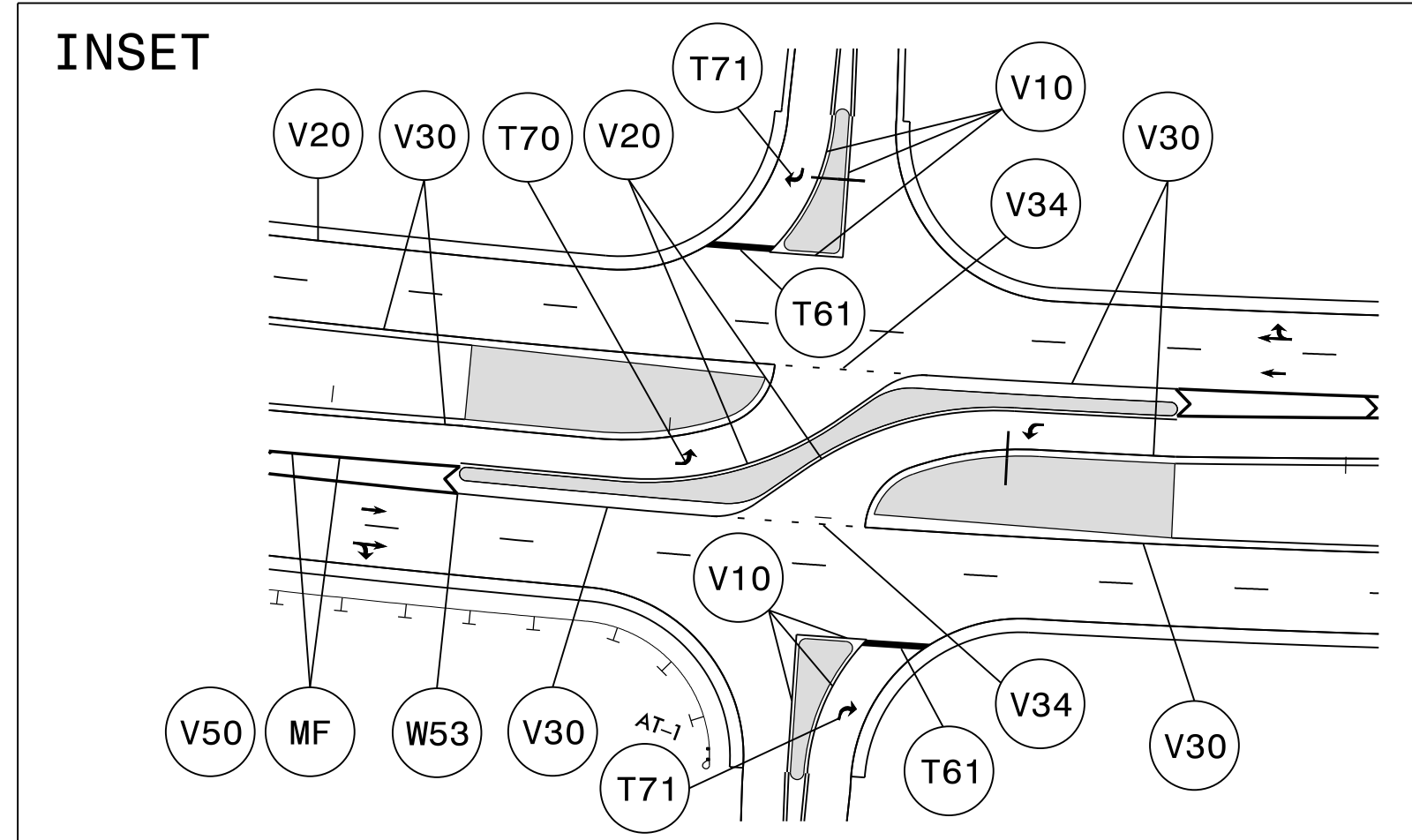

**PAVEMENT MARKING SCHEDULE**

PAVEMENT MARKING LINES		PAVEMENT MARKING SYMBOLS	
T41	WHITE DIAGONAL THERMOPLASTIC (8", 90 mils)	T70	LEFT TURN ARROW THERMOPLASTIC
T61	WHITE STOPBAR THERMOPLASTIC (24", 90 mils)	T71	RIGHT TURN ARROW THERMOPLASTIC
V1	WHITE EDGELINE POLYUREA (4", 20 mils)	T72	STRAIGHT ARROW THERMOPLASTIC
V10	YELLOW EDGELINE POLYUREA (4", 20 mils)	T74	COMBO STRAIGHT / RIGHT ARROW THERMOPLASTIC
V13	YELLOW DOUBLE CENTER LINE POLYUREA (4", 20 mils)	T77	U-TURN ARROW THERMOPLASTIC
V20	WHITE EDGELINE POLYUREA (6", 20 mils)		
V22	10 FT. WHITE SKIP POLYUREA (6", 20 mils)		
V23	3' - 9' SP WHITE MINISKIP POLYUREA (6", 20 mils)		
V24	2' - 6' SP WHITE MINISKIP POLYUREA (6", 20 mils)		
V30	YELLOW EDGELINE POLYUREA (6", 20 mils)		
V34	2' - 6' SP YELLOW MINISKIP POLYUREA (6", 20 mils)		
V50	WHITE GORE LINE POLYUREA (12", 20 mils)		
		PAVEMENT MARKERS	
		ME	YELLOW AND YELLOW PERMANENT SNOWPLOWABLE
		MF	CRYSTAL AND RED PERMANENT SNOWPLOWABLE



2610 WYCLIFF ROAD  
SUITE 410  
RALEIGH, NC 27607  
PHONE: 919-881-9939  
NC COA No. F-0929

**PAVEMENT MARKING DETAIL**

16-APR-2020 10:41 P:\500715420\CAD\CIVIL\N-2233BB\Tr\of\ic\pmp\Plans\R2233BB\_PMP\_PMP\_16.dgn AT PC0036KJ

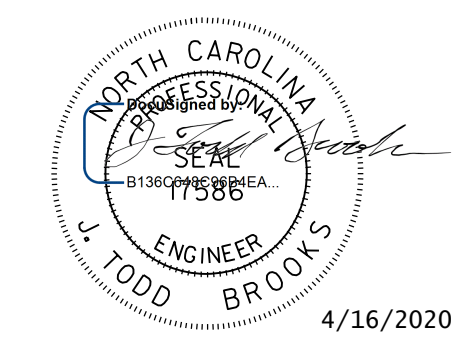
TIP NO. R-2233BB	SHEET NO. PMP-17
APPROVED: _____	
DATE: _____	
SEAL 	
<b>DOCUMENT NOT CONSIDERED FINAL UNLESS ALL SIGNATURES COMPLETED</b>	

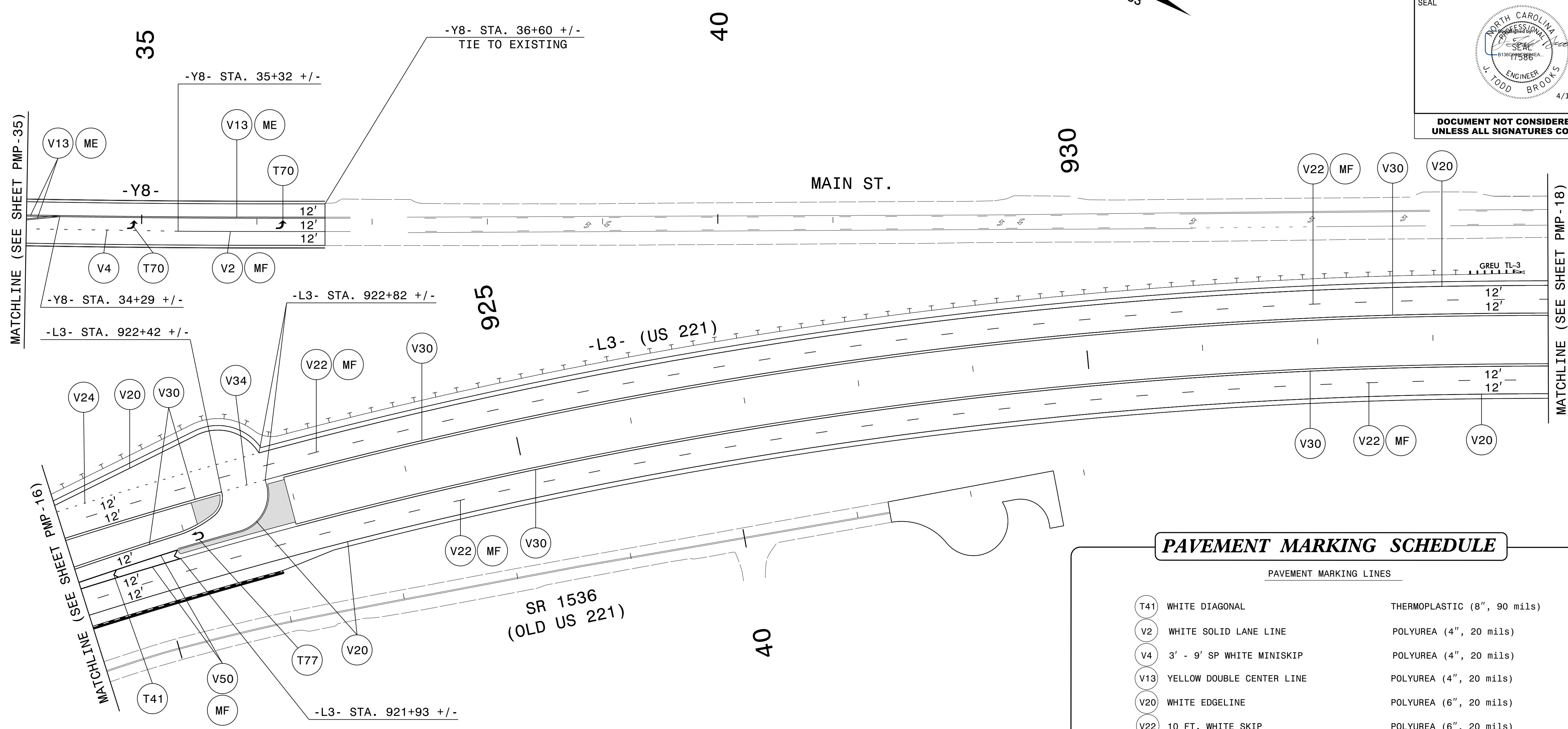

PAVEMENT MARKING SCHEDULE		
PAVEMENT MARKING LINES		
T41	WHITE DIAGONAL	THERMOPLASTIC (8", 90 mils)
V2	WHITE SOLID LANE LINE	POLYUREA (4", 20 mils)
V4	3' - 9' SP WHITE MINISKIP	POLYUREA (4", 20 mils)
V13	YELLOW DOUBLE CENTER LINE	POLYUREA (4", 20 mils)
V20	WHITE EDGELINE	POLYUREA (6", 20 mils)
V22	10 FT. WHITE SKIP	POLYUREA (6", 20 mils)
V24	2' - 6' SP WHITE MINISKIP	POLYUREA (6", 20 mils)
V30	YELLOW EDGELINE	POLYUREA (6", 20 mils)
V34	2' - 6' SP YELLOW MINISKIP	POLYUREA (6", 20 mils)
V50	WHITE GORE LINE	POLYUREA (12", 20 mils)
PAVEMENT MARKING SYMBOLS		
T70	LEFT TURN ARROW	THERMOPLASTIC
T77	U-TURN ARROW	THERMOPLASTIC
PAVEMENT MARKERS		
ME	YELLOW AND YELLOW	PERMANENT SNOWFLOWABLE
MF	CRYSTAL AND RED	PERMANENT SNOWFLOWABLE

16-APP-2020-1041  
P:\50075\20\CAD\Civil\N-2233BB\Tr of fic\PM\Plans\R2233BB\_PMP\_PMP\_17.dgn  
writes  
AT PC0036KJ



**Dewberry**  
2610 WYCLIFF ROAD  
SUITE 410  
RALEIGH, NC 27607  
PHONE: 919-881-9939  
NC COA No. F-0929

**PAVEMENT MARKING DETAIL**



TIP NO. R-2233BB	SHEET NO. PMP-18
APPROVED: _____	
DATE: _____	
SEAL	
<b>DOCUMENT NOT CONSIDERED FINAL UNLESS ALL SIGNATURES COMPLETED</b>	

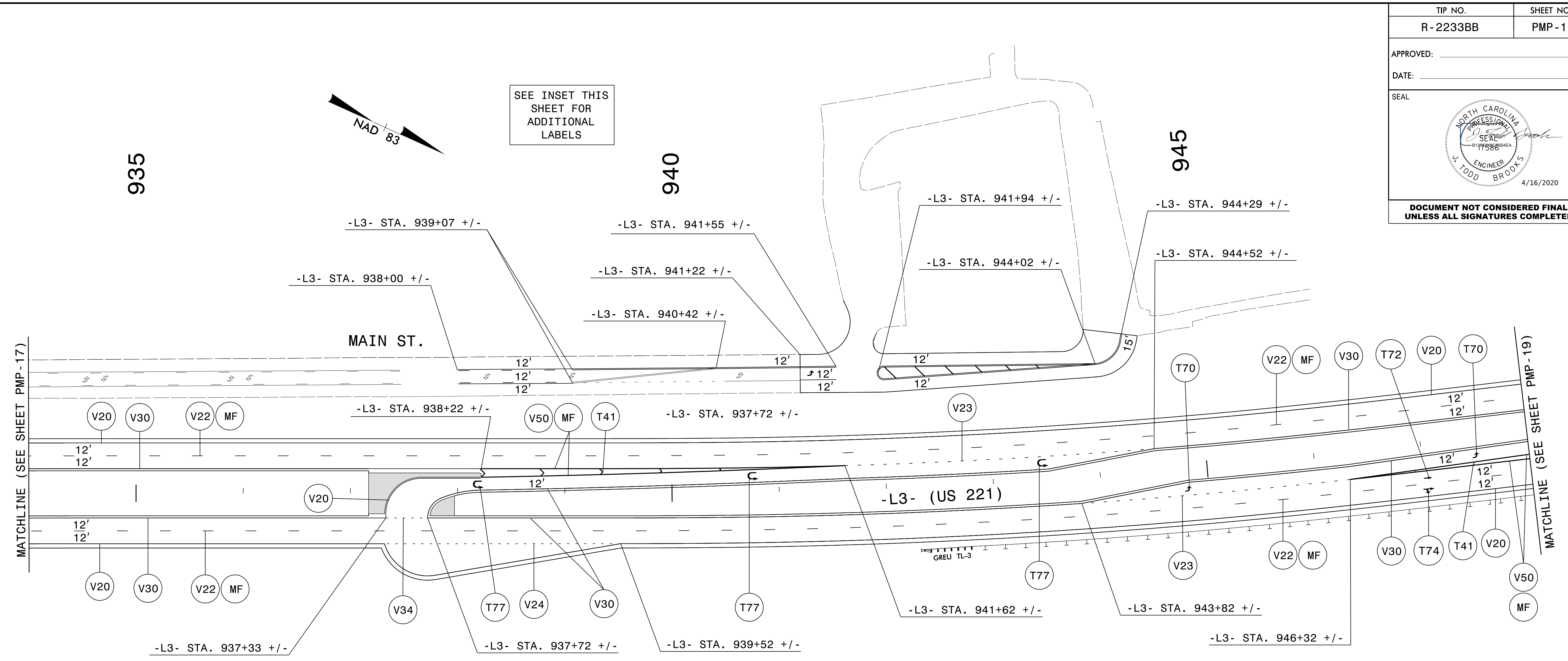

**PAVEMENT MARKING SCHEDULE**

PAVEMENT MARKING LINES	
T41	WHITE DIAGONAL THERMOPLASTIC (8", 90 mils)
T42	YELLOW DIAGONAL THERMOPLASTIC (8", 90 mils)
V1	WHITE EDGELINE POLYUREA (4", 20 mils)
V2	WHITE SOLID LANE LINE POLYUREA (4", 20 mils)
V11	YELLOW SINGLE CENTER POLYUREA (4", 20 mils)
V12	10 FT. YELLOW SKIP POLYUREA (4", 20 mils)
V13	YELLOW DOUBLE CENTER POLYUREA (4", 20 mils)
V20	WHITE EDGELINE POLYUREA (6", 20 mils)
V22	10 FT. WHITE SKIP POLYUREA (6", 20 mils)
V23	3' - 9" SP WHITE MINISKIP POLYUREA (6", 20 mils)
V24	2' - 6" SP WHITE MINISKIP POLYUREA (6", 20 mils)
V30	YELLOW EDGELINE POLYUREA (6", 20 mils)
V34	2' - 6" SP YELLOW MINISKIP POLYUREA (6", 20 mils)
V50	WHITE GORE LINE POLYUREA (12", 20 mils)
PAVEMENT MARKING SYMBOLS	
T70	LEFT TURN ARROW THERMOPLASTIC
T72	STRAIGHT ARROW THERMOPLASTIC
T74	COMBO STRAIGHT / RIGHT ARROW THERMOPLASTIC
T77	U-TURN ARROW THERMOPLASTIC
PAVEMENT MARKERS	
ME	YELLOW AND YELLOW PERMANENT SNOWPLOWABLE
MF	CRYSTAL AND RED PERMANENT SNOWPLOWABLE

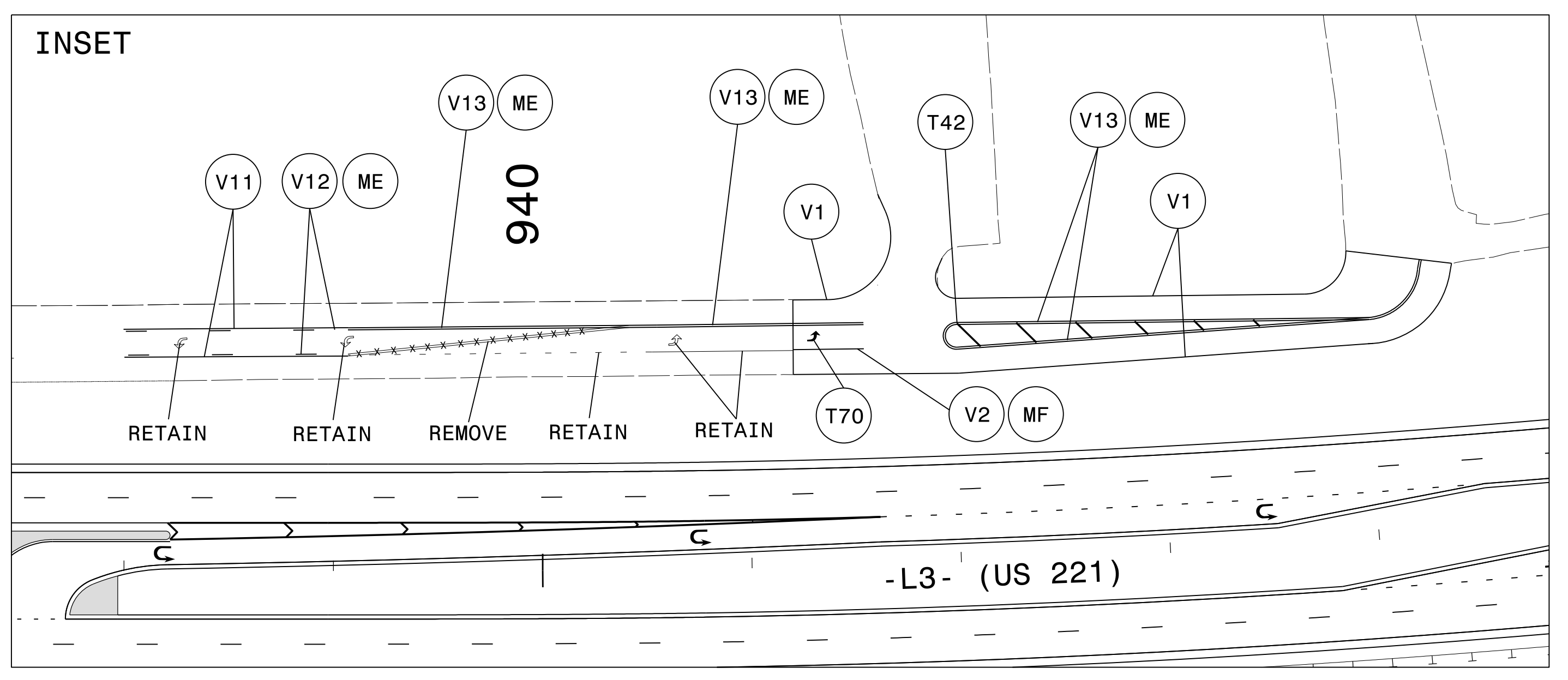

**PAVEMENT MARKING DETAIL**

I6-APP-2020\_10.dwg  
 P:\500715\20\CAD\CIVIL\NR-2233BB\Tr of fic\PMP\Plans\R2233BB\_PMP\_PMP\_18.dwg  
 JTB

2610 WYCLIFF ROAD  
 SUITE 410  
 RALEIGH, NC 27607  
 PHONE: 919-881-9939  
 NC COA No. F-0929



APPROVED: \_\_\_\_\_

DATE: \_\_\_\_\_

SEAL

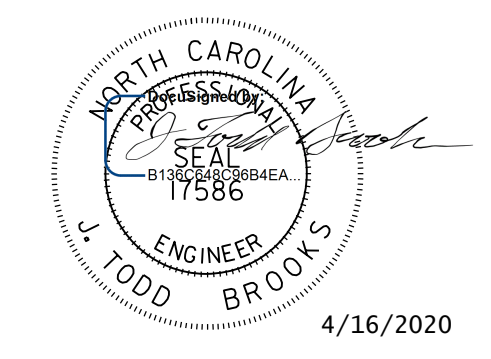

**DOCUMENT NOT CONSIDERED FINAL  
UNLESS ALL SIGNATURES COMPLETED**

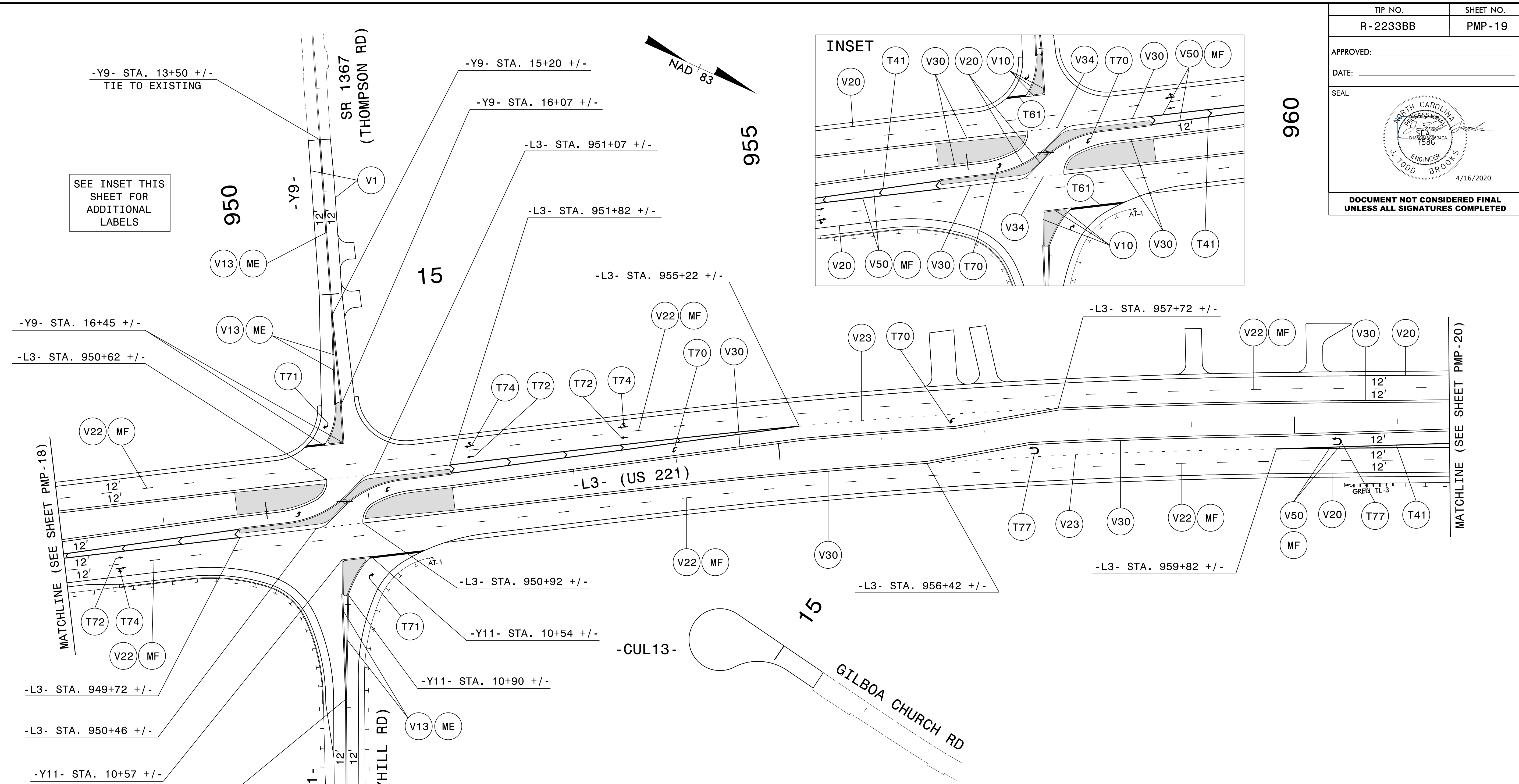

SEE INSET THIS SHEET FOR ADDITIONAL LABELS

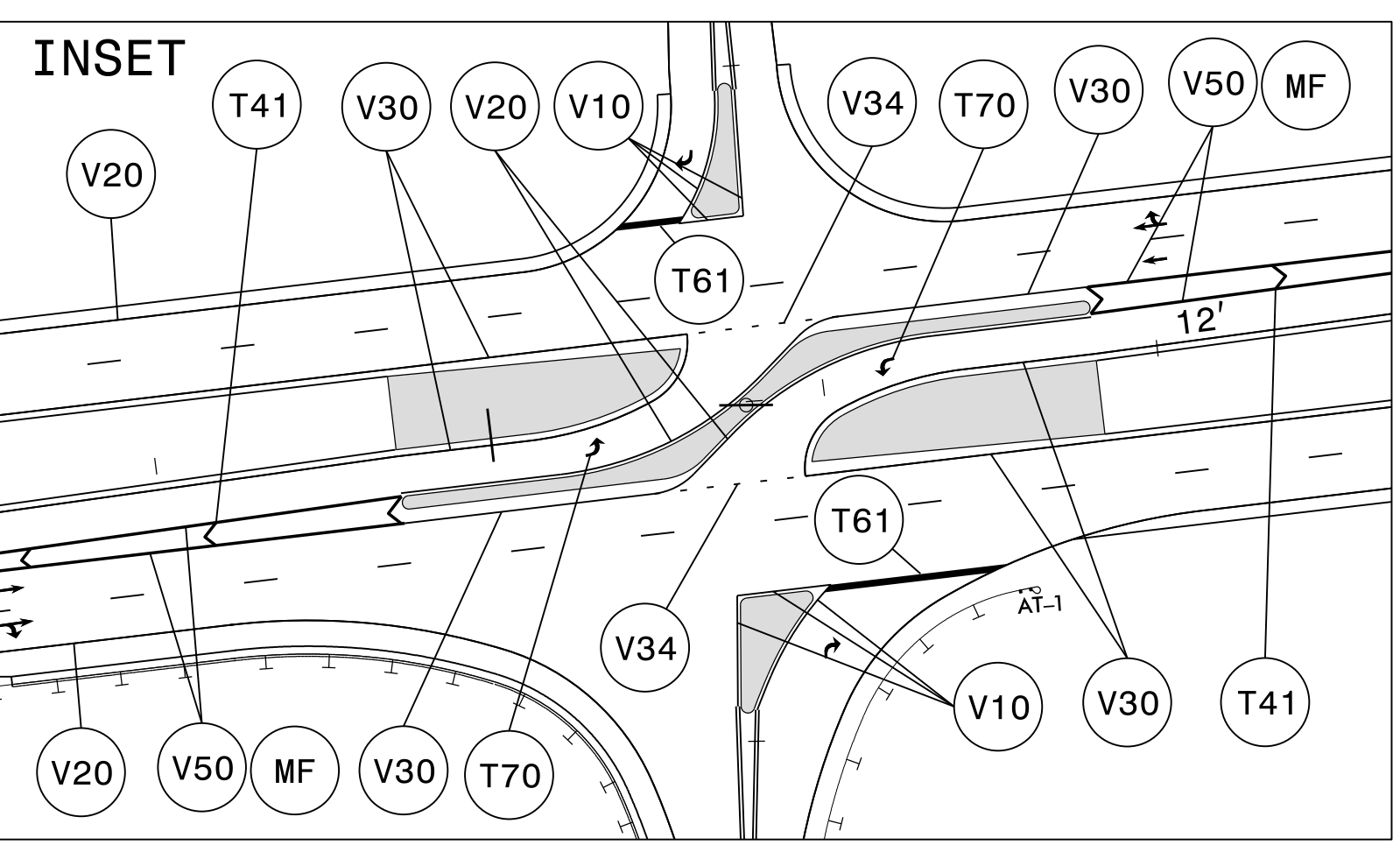

**PAVEMENT MARKING SCHEDULE**

PAVEMENT MARKING LINES		PAVEMENT MARKING SYMBOLS	
T41	WHITE DIAGONAL	T70	LEFT TURN ARROW
T61	WHITE STOPBAR	T71	RIGHT TURN ARROW
V1	WHITE EDGELINE	T72	STRAIGHT ARROW
V10	YELLOW EDGELINE	T74	COMBO STRAIGHT / RIGHT ARROW
V13	YELLOW DOUBLE CENTER LINE	T77	U-TURN ARROW
V20	WHITE EDGELINE		
V22	10 FT. WHITE SKIP	ME	YELLOW AND YELLOW
V23	3' - 9' SP WHITE MINISKIP	MF	CRYSTAL AND RED
V24	2' - 6' SP WHITE MINISKIP		
V30	YELLOW EDGELINE		
V34	2' - 6' SP YELLOW MINISKIP		
V50	WHITE GORE LINE		

**PAVEMENT MARKING DETAIL**



2610 WYCLIFF ROAD  
 SUITE 410  
 RALEIGH, NC 27607  
 PHONE: 919-881-9939  
 NC COA No. F-0929

16-APP-2020\_1042  
 P:\5007\5020\CAD\CIVIL\NR-2233BB\Tr-off\ic:\PMP\Plans\NR-2233BB\_PMP\_PMP\_19.dgn  
 JTB



TIP NO. R-2233BB	SHEET NO. PMP-20
APPROVED: _____	
DATE: _____	
SEAL	
<b>DOCUMENT NOT CONSIDERED FINAL UNLESS ALL SIGNATURES COMPLETED</b>	

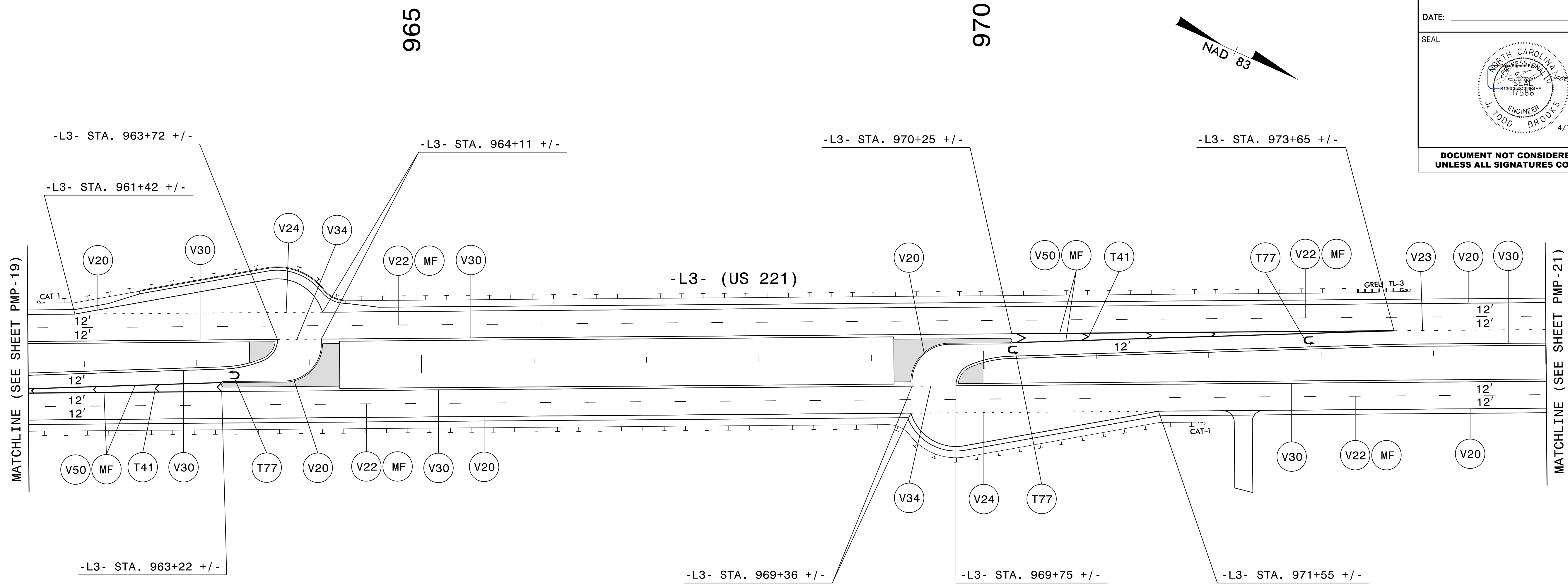

**PAVEMENT MARKING SCHEDULE**

PAVEMENT MARKING LINES

(T41)	WHITE DIAGONAL	THERMOPLASTIC (8", 90 mils)
(V20)	WHITE EDGELINE	POLYUREA (6", 20 mils)
(V22)	10 FT. WHITE SKIP	POLYUREA (6", 20 mils)
(V23)	3' - 9' SP WHITE MINISKIP	POLYUREA (6", 20 mils)
(V24)	2' - 6' SP WHITE MINISKIP	POLYUREA (6", 20 mils)
(V30)	YELLOW EDGELINE	POLYUREA (6", 20 mils)
(V34)	2' - 6' SP YELLOW MINISKIP	POLYUREA (6", 20 mils)
(V50)	WHITE GORE LINE	POLYUREA (12", 20 mils)

PAVEMENT MARKING SYMBOLS

(T77)	U-TURN ARROW	THERMOPLASTIC
-------	--------------	---------------

PAVEMENT MARKERS

(MF)	CRYSTAL AND RED	PERMANENT SNOWPLOWABLE
------	-----------------	------------------------

I6-APP-2020\_1042  
 P:\50075\20\CAD\Civil\N-2233BB\Tr of fic\PM\Plans\R2233BB\_PMP\_PMP\_20.dgn  
 JTB  
 AT PC0036KJ



2610 WYCLIFF ROAD  
 SUITE 410  
 RALEIGH, NC 27607  
 PHONE: 919-881-9939  
 NC COA No. F-0929

**PAVEMENT MARKING DETAIL**

TIP NO. R-2233BB	SHEET NO. PMP - 21
APPROVED: _____	
DATE: _____	
SEAL	
<b>DOCUMENT NOT CONSIDERED FINAL UNLESS ALL SIGNATURES COMPLETED</b>	

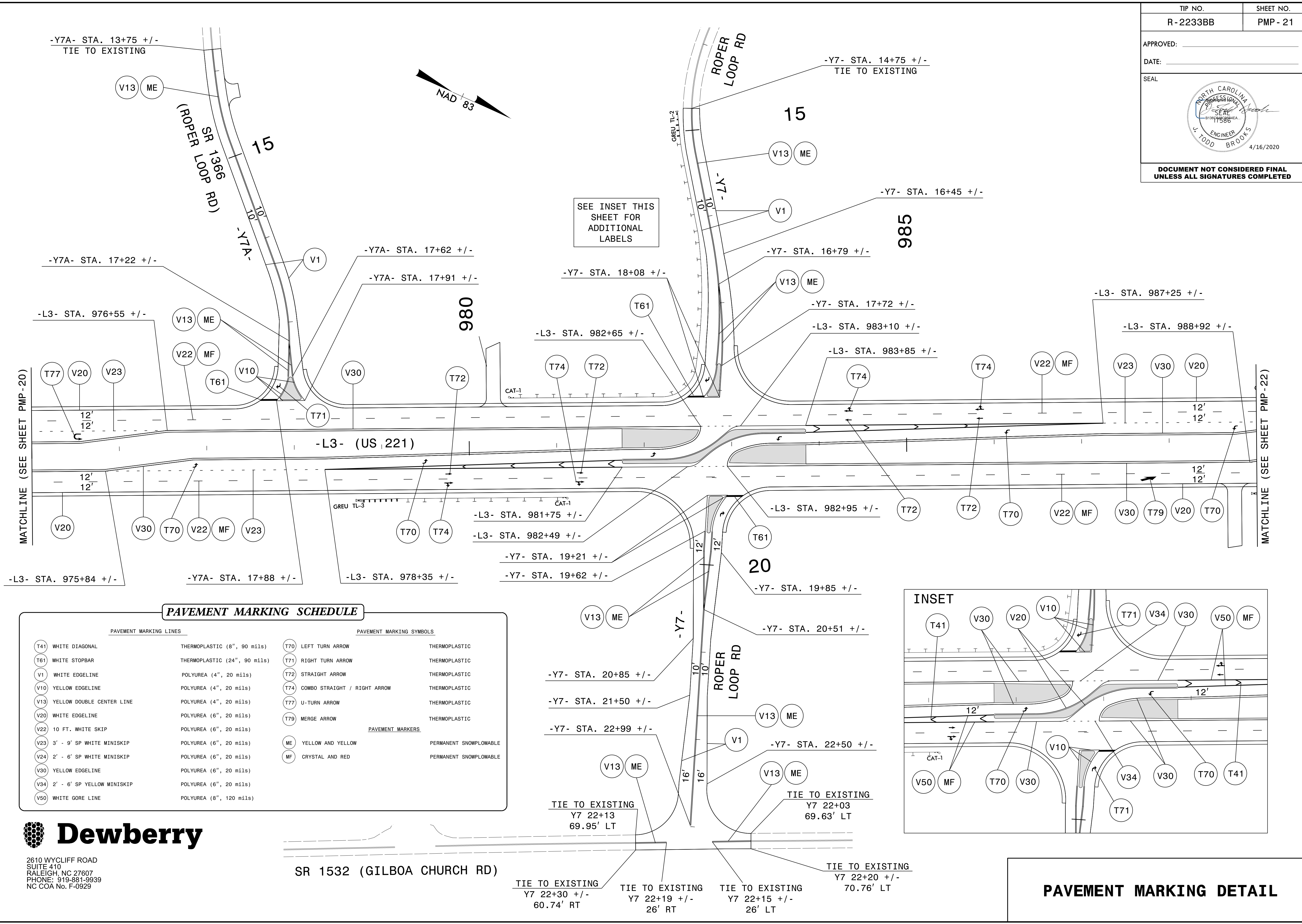

SEE INSET THIS SHEET FOR ADDITIONAL LABELS

MATCHLINE (SEE SHEET PMP-20)

MATCHLINE (SEE SHEET PMP-22)

**PAVEMENT MARKING SCHEDULE**

PAVEMENT MARKING LINES		PAVEMENT MARKING SYMBOLS	
(T41) WHITE DIAGONAL	THERMOPLASTIC (8", 90 mils)	(T70) LEFT TURN ARROW	THERMOPLASTIC
(T61) WHITE STOPBAR	THERMOPLASTIC (24", 90 mils)	(T71) RIGHT TURN ARROW	THERMOPLASTIC
(V1) WHITE EDGELINE	POLYUREA (4", 20 mils)	(T72) STRAIGHT ARROW	THERMOPLASTIC
(V10) YELLOW EDGELINE	POLYUREA (4", 20 mils)	(T74) COMBO STRAIGHT / RIGHT ARROW	THERMOPLASTIC
(V13) YELLOW DOUBLE CENTER LINE	POLYUREA (4", 20 mils)	(T77) U-TURN ARROW	THERMOPLASTIC
(V20) WHITE EDGELINE	POLYUREA (6", 20 mils)	(T79) MERGE ARROW	THERMOPLASTIC
(V22) 10 FT. WHITE SKIP	POLYUREA (6", 20 mils)	(ME) YELLOW AND YELLOW	PERMANENT SNOWPLOWABLE
(V23) 3' - 9" SP WHITE MINISKIP	POLYUREA (6", 20 mils)	(MF) CRYSTAL AND RED	PERMANENT SNOWPLOWABLE
(V24) 2' - 6" SP WHITE MINISKIP	POLYUREA (6", 20 mils)		
(V30) YELLOW EDGELINE	POLYUREA (6", 20 mils)		
(V34) 2' - 6" SP YELLOW MINISKIP	POLYUREA (6", 20 mils)		
(V50) WHITE GOORE LINE	POLYUREA (8", 120 mils)		

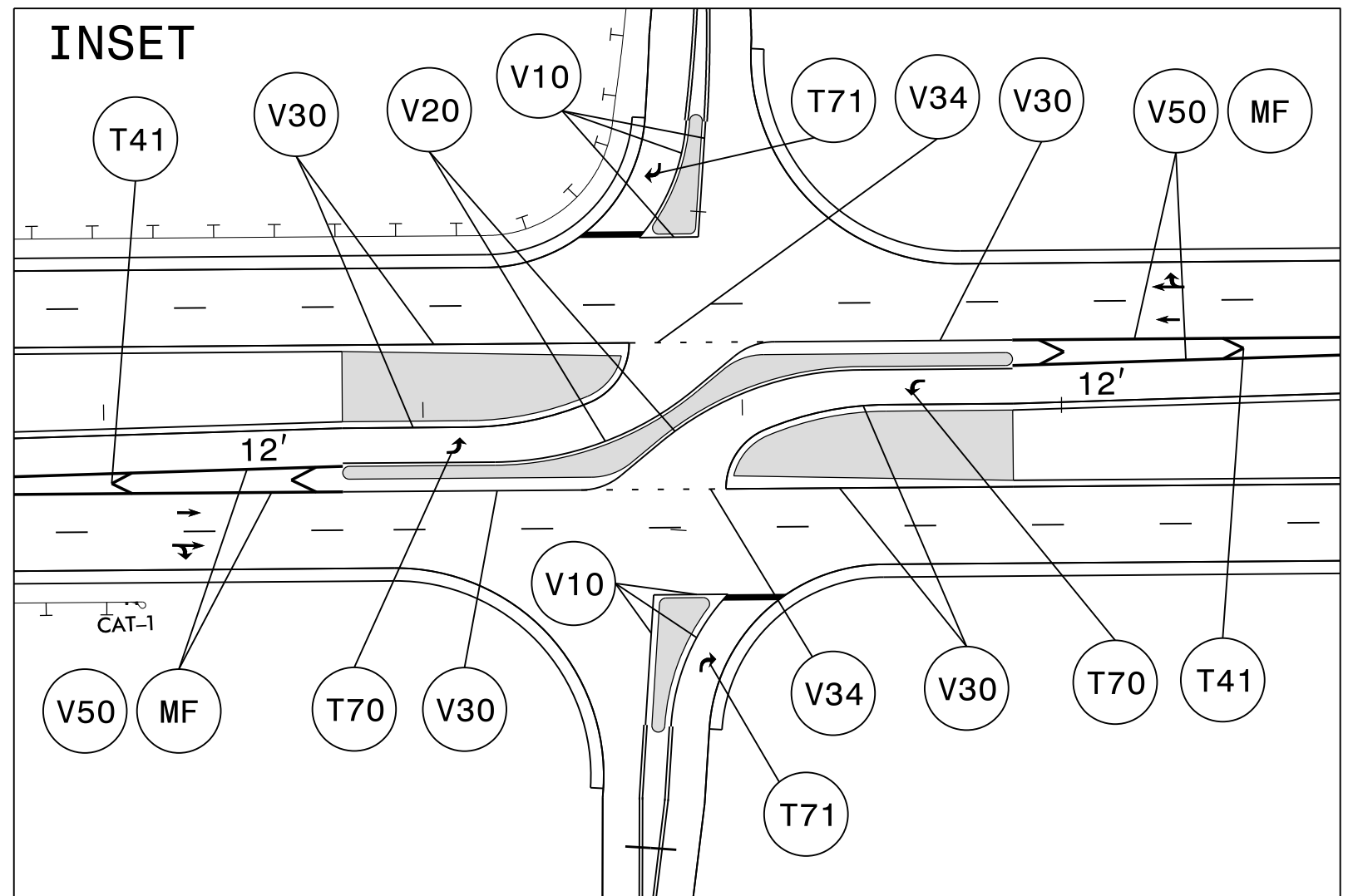

**PAVEMENT MARKING DETAIL**

2610 WYCLIFF ROAD  
SUITE 410  
RALEIGH, NC 27607  
PHONE: 919-881-9939  
NC COA No. F-0929

16-APR-2020 10:42 P:\50075420\CAD\CIVIL\N-2233BB\Tr-offic\PM\Plans\R2233BB\_PMP\_PMP\_21.dgn  
JTB



TIP NO. R-2233BB	SHEET NO. PMP-22
APPROVED: _____	
DATE: _____	
SEAL	
<b>DOCUMENT NOT CONSIDERED FINAL UNLESS ALL SIGNATURES COMPLETED</b>	

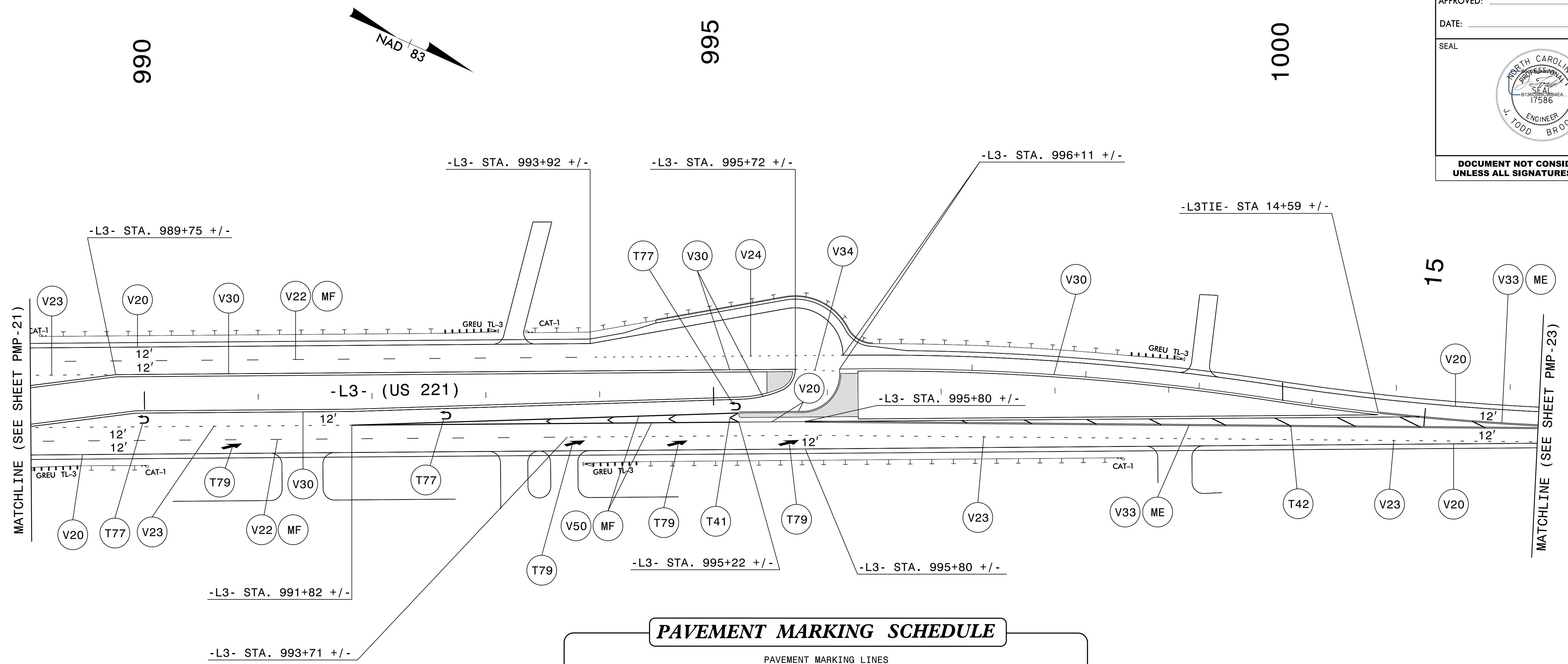

**PAVEMENT MARKING SCHEDULE**

PAVEMENT MARKING LINES		
(T41)	WHITE DIAGONAL	THERMOPLASTIC (8", 90 mils)
(T42)	YELLOW DIAGONAL	THERMOPLASTIC (8", 90 mils)
(V20)	WHITE EDGELINE	POLYUREA (6", 20 mils)
(V22)	10 FT. WHITE SKIP	POLYUREA (6", 20 mils)
(V23)	3' - 9' SP WHITE MINISKIP	POLYUREA (6", 20 mils)
(V24)	2' - 6' SP WHITE MINISKIP	POLYUREA (6", 20 mils)
(V30)	YELLOW EDGELINE	POLYUREA (6", 20 mils)
(V33)	YELLOW DOUBLE CENTER LINE	POLYUREA (6", 20 mils)
(V34)	2' - 6' SP YELLOW MINISKIP	POLYUREA (6", 20 mils)
(V50)	WHITE GORE LINE	POLYUREA (12", 20 mils)
PAVEMENT MARKING SYMBOLS		
(T77)	U-TURN ARROW	THERMOPLASTIC
(T79)	MERGE ARROW	THERMOPLASTIC
PAVEMENT MARKERS		
(ME)	YELLOW AND YELLOW	PERMANENT SNOWPLOWABLE
(MF)	CRYSTAL AND RED	PERMANENT SNOWPLOWABLE

**PAVEMENT MARKING DETAIL**

I6-APP-2020\_1042  
 P:\50075420\CAD\CIVIL\N-2233BB\Tr-offic\PM\Plans\R2233BB\_PMP\_PMP\_22.dgn  
 JTB  
 AT PC0036KJ

2610 WYCLIFF ROAD  
 SUITE 410  
 RALEIGH, NC 27607  
 PHONE: 919-881-9939  
 NC COA No. F-0929

TIP NO. R-2233BB	SHEET NO. PMP-23
APPROVED: _____	
DATE: _____	
SEAL	
DOCUMENT NOT CONSIDERED FINAL UNLESS ALL SIGNATURES COMPLETED	

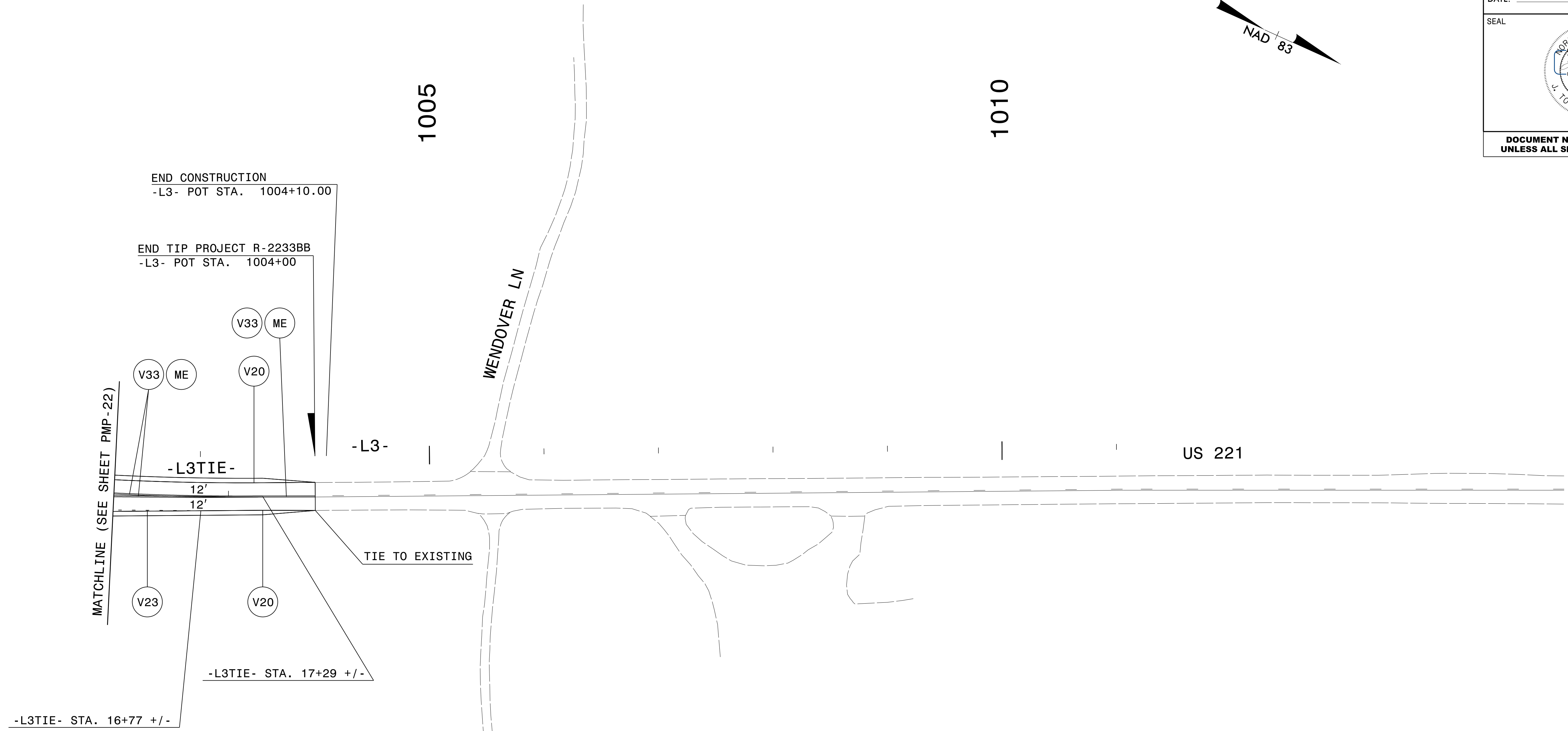
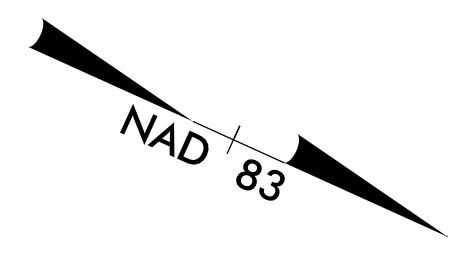

PAVEMENT MARKING SCHEDULE		
PAVEMENT MARKING LINES		
V20	WHITE EDGELINE	POLYUREA (4", 20 mils)
V23	3' - 9' SP WHITE MINISKIP	POLYUREA (4", 20 mils)
V33	YELLOW DOUBLE CENTER LINE	POLYUREA (4", 20 mils)
PAVEMENT MARKERS		
ME	YELLOW AND YELLOW	PERMANENT SNOWPLOWABLE



2610 WYCLIFF ROAD  
SUITE 410  
RALEIGH, NC 27607  
PHONE: 919-881-9939  
NC COA No. F-0929

**PAVEMENT MARKING DETAIL**

I6-APP-2020\_1042  
P:\50075\20\CAD\CIVIL\N-2233BB\Tr of fig\PM\Plans\R2233BB\_PMP\_PMP\_23.dgn  
writes AT PC0036KJ

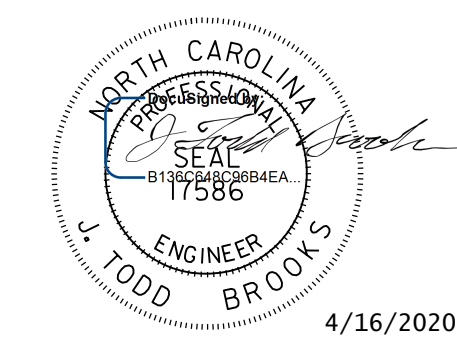

TIP NO. R-2233BB	SHEET NO. PMP-24
APPROVED: _____	
DATE: _____	
SEAL	
	
DOCUMENT NOT CONSIDERED FINAL UNLESS ALL SIGNATURES COMPLETED	

### PAVEMENT MARKING SCHEDULE

PAVEMENT MARKING LINES		
T42	YELLOW DIAGONAL	THERMOPLASTIC (8", 90 mils)
T61	WHITE STOPBAR	THERMOPLASTIC (24", 90 mils)
V1	WHITE EDGELINE	POLYUREA (4", 20 mils)
V2	WHITE SOLID LANE LINE	POLYUREA (4", 20 mils)
V3	10 FT. WHITE SKIP	POLYUREA (4", 20 mils)
V4	3' - 9' SP WHITE MINISKIP	POLYUREA (4", 20 mils)
V5	2' - 6' SP WHITE MINISKIP	POLYUREA (4", 20 mils)
V10	YELLOW EDGELINE	POLYUREA (4", 20 mils)
V13	YELLOW DOUBLE CENTER LINE	POLYUREA (4", 20 mils)
V34	2' - 6' SP YELLOW MINISKIP	POLYUREA (6", 20 mils)
PAVEMENT MARKING SYMBOLS		
T70	LEFT TURN ARROW	THERMOPLASTIC
T71	RIGHT TURN ARROW	THERMOPLASTIC
T72	STRAIGHT ARROW	THERMOPLASTIC
T74	COMBO STRAIGHT / RIGHT ARROW	THERMOPLASTIC
PAVEMENT MARKERS		
ME	YELLOW AND YELLOW	PERMANENT SNOWPLOWABLE
MF	CRYSTAL AND RED	PERMANENT SNOWPLOWABLE

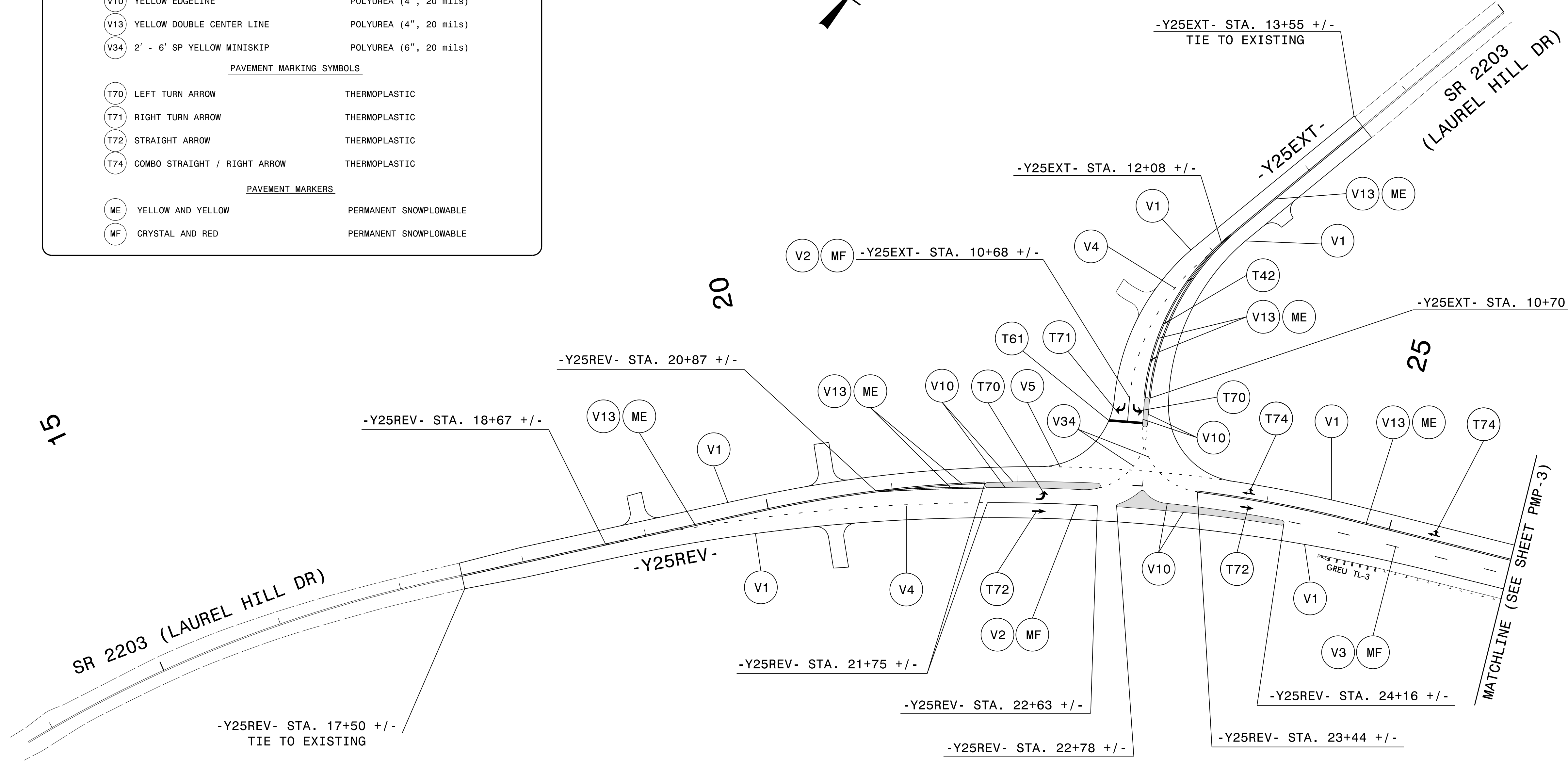
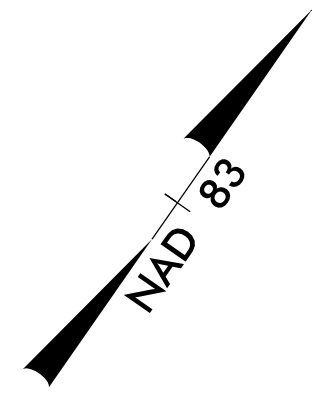

I6-APP-2020\_1042  
P:\500715\20\CAD\CIVIL\N-2233BB\Tr of fic\PM\Plans\2233BB\_PMP\_PMP\_24.dgn  
JTB



2610 WYCLIFF ROAD  
SUITE 410  
RALEIGH, NC 27607  
PHONE: 919-881-9939  
NC COA No. F-0929

**PAVEMENT MARKING DETAIL**

TIP NO. R-2233BB	SHEET NO. PMP-25
APPROVED: _____	
DATE: _____	
SEAL	
<b>DOCUMENT NOT CONSIDERED FINAL UNLESS ALL SIGNATURES COMPLETED</b>	

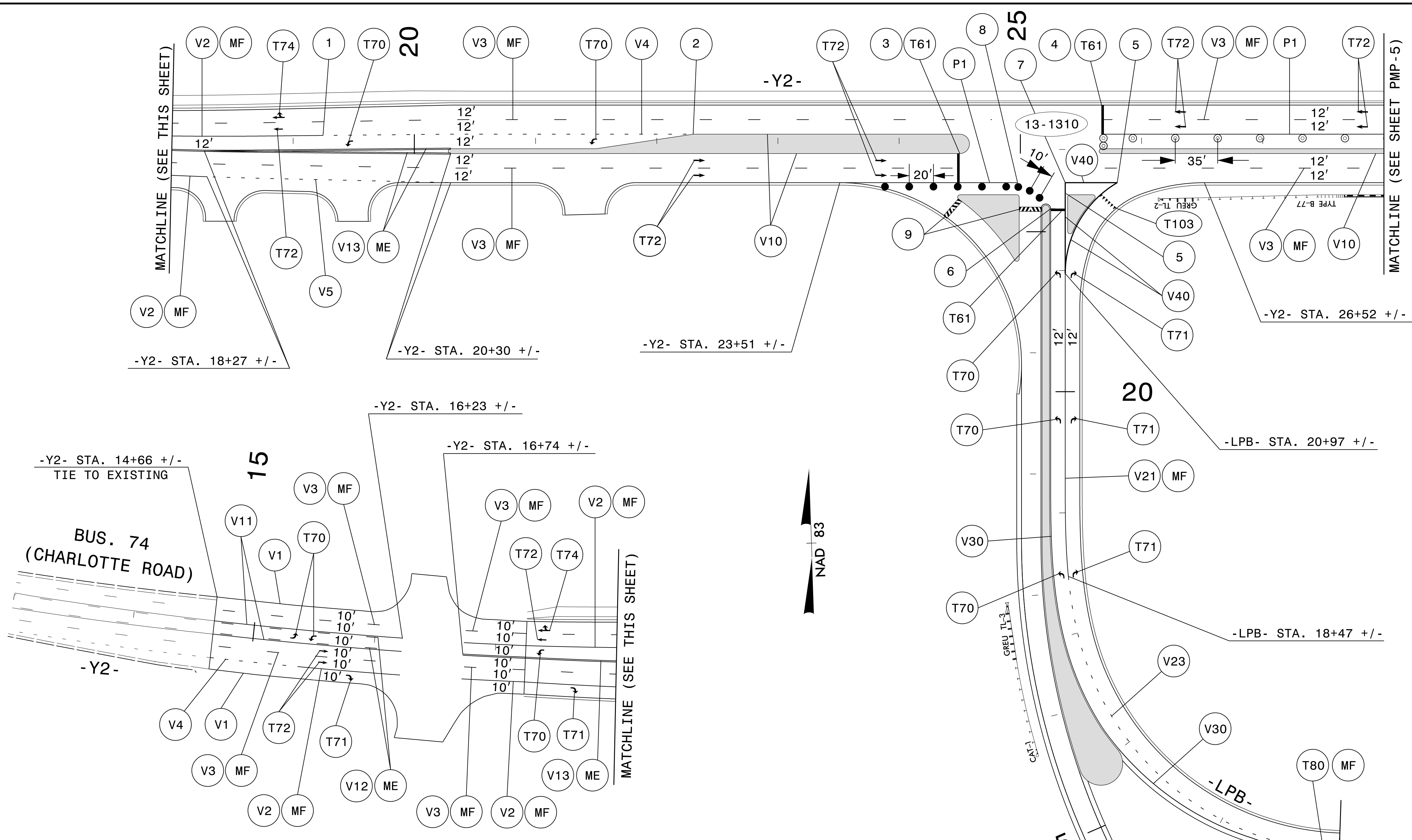

SEE SIGNAL PLANS FOR  
FINAL STOP BAR LOCATIONS

- 1 -Y2- STA. 19+25 +/-
- 2 -Y3- STA. 22+30 +/-
- 3 -Y2- STA. 24+50 +/-
- 4 -Y2- STA. 25+67 +/-
- 5 -Y2- STA. 25+80 +/-
- 6 -LPB- STA. 21+51 +/-
- 7 -Y2- STA. 25+37 +/-
- 8 -Y2- STA. 25+00 +/-

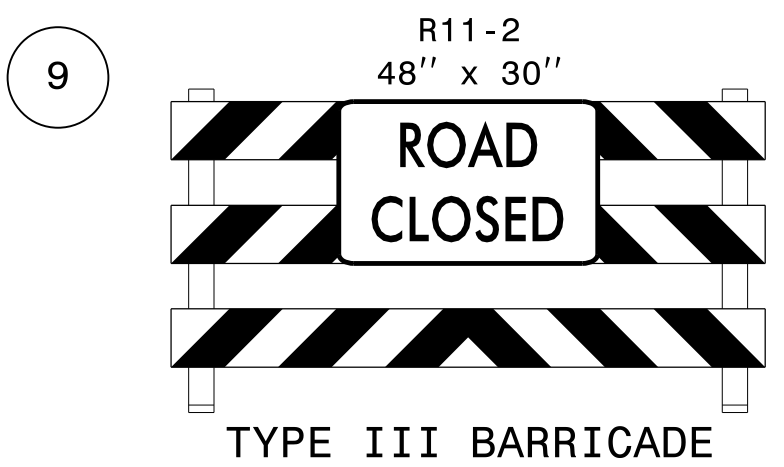

**PAVEMENT MARKING SCHEDULE**

PAVEMENT MARKING LINES		PAVEMENT MARKING SYMBOLS			
P1	WHITE EDGELINE	PAINT (4")			
T61	WHITE STOPBAR	THERMOPLASTIC (24", 90 mils)			
T103	YIELD LINE TRIANGLE	THERMOPLASTIC (24")			
V1	WHITE EDGELINE	POLYUREA (4", 20 mils)	T70	LEFT TURN ARROW	THERMOPLASTIC
V2	WHITE SOLID LANE LINE	POLYUREA (4", 20 mils)	T71	RIGHT TURN ARROW	THERMOPLASTIC
V3	10 FT. WHITE SKIP	POLYUREA (4", 20 mils)	T72	STRAIGHT ARROW	THERMOPLASTIC
V4	3' - 9" SP WHITE MINISKIP	POLYUREA (4", 20 mils)	T74	COMBO STRAIGHT / RIGHT ARROW	THERMOPLASTIC
V5	2' - 6" SP WHITE MINISKIP	POLYUREA (4", 20 mils)	T80	WRONG WAY RAMP ARROW	THERMOPLASTIC
V10	YELLOW EDGELINE	POLYUREA (4", 20 mils)			
V11	YELLOW SINGLE CENTER LINE	POLYUREA (4", 20 mils)	ME	YELLOW AND YELLOW	PERMANENT SNOWPLOWABLE
V12	10 FT. YELLOW SKIP	POLYUREA (4", 20 mils)	MF	CRYSTAL AND RED	PERMANENT SNOWPLOWABLE
V13	YELLOW DOUBLE CENTER LINE	POLYUREA (4", 20 mils)			
V20	WHITE EDGELINE	POLYUREA (6", 20 mils)			
V21	WHITE SOLID LANE LINE	POLYUREA (6", 20 mils)			
V23	3' - 9" SP WHITE MINISKIP	POLYUREA (6", 20 mils)			
V30	YELLOW EDGELINE	POLYUREA (6", 20 mils)			
V40	WHITE GORE LINE	POLYUREA (8", 20 mils)			

**LEGEND**

- 13-XXXX SIGNAL INVENTORY NUMBER
- TUBULAR MARKER
- DRUM
- TYPE III BARRICADE

**PAVEMENT MARKING DETAIL**

I6-APP-2020\_1042  
 P:\500715\20\CAD\CIVIL\N-2233BB\Tr of fic\PMP\Plans\R2233BB\_PMP\_PMP\_25.dgn  
 J:\wiles

2610 WYCLIFF ROAD  
SUITE 410  
RALEIGH, NC 27607  
PHONE: 919-881-9939  
NC COA No. F-0929



TIP NO. R-2233BB	SHEET NO. PMP-26
APPROVED: _____	
DATE: _____	
SEAL	
<b>DOCUMENT NOT CONSIDERED FINAL UNLESS ALL SIGNATURES COMPLETED</b>	

13-XXXX SIGNAL INVENTORY NUMBER

TYPE III BARRICADE

SEE SIGNAL PLANS FOR  
FINAL STOP BAR LOCATIONS

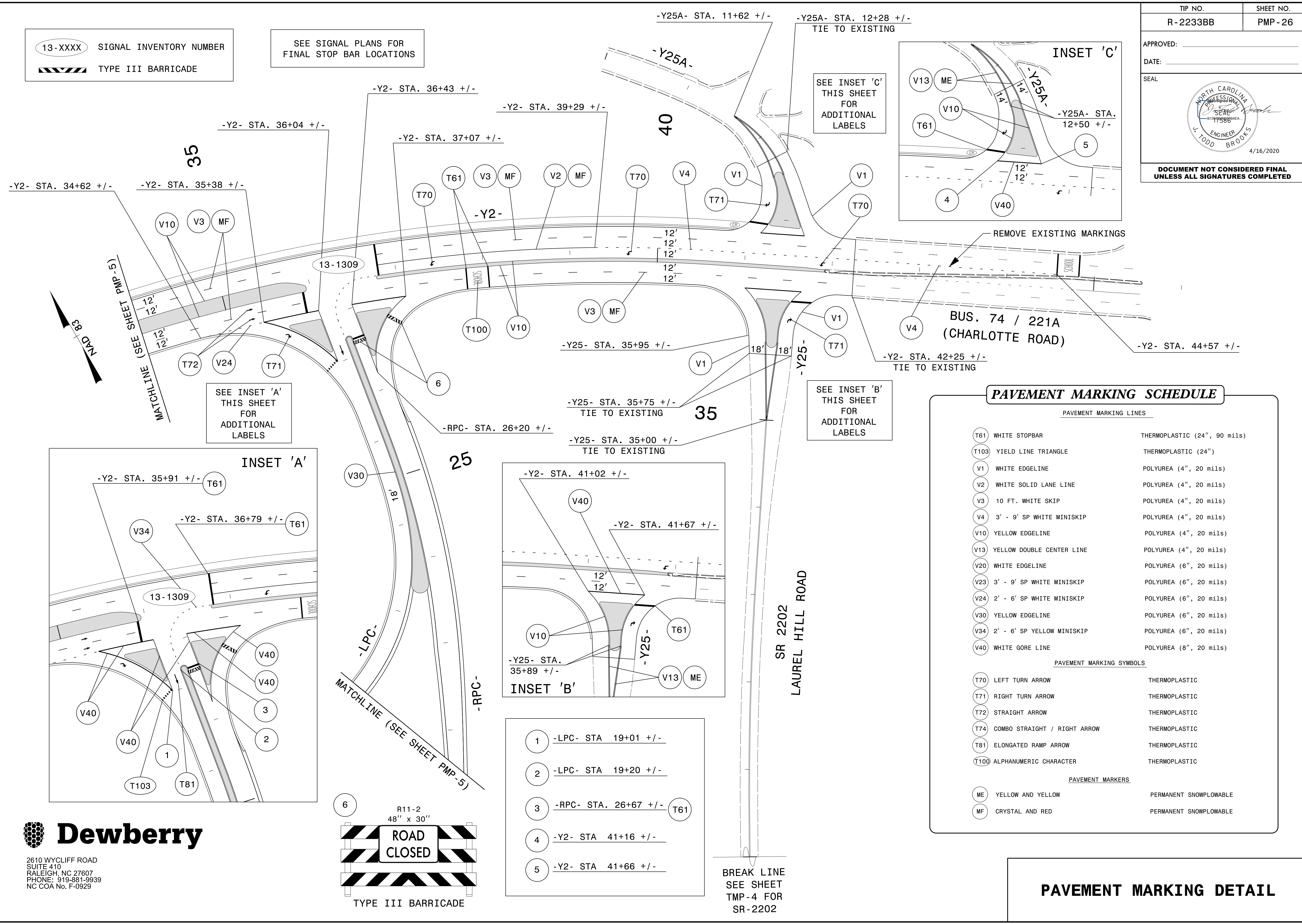

**PAVEMENT MARKING SCHEDULE**

PAVEMENT MARKING LINES	
T61	WHITE STOPBAR THERMOPLASTIC (24", 90 mils)
T103	YIELD LINE TRIANGLE THERMOPLASTIC (24")
V1	WHITE EDGELINE POLYUREA (4", 20 mils)
V2	WHITE SOLID LANE LINE POLYUREA (4", 20 mils)
V3	10 FT. WHITE SKIP POLYUREA (4", 20 mils)
V4	3' - 9' SP WHITE MINISKIP POLYUREA (4", 20 mils)
V10	YELLOW EDGELINE POLYUREA (4", 20 mils)
V13	YELLOW DOUBLE CENTER LINE POLYUREA (4", 20 mils)
V20	WHITE EDGELINE POLYUREA (6", 20 mils)
V23	3' - 9' SP WHITE MINISKIP POLYUREA (6", 20 mils)
V24	2' - 6' SP WHITE MINISKIP POLYUREA (6", 20 mils)
V30	YELLOW EDGELINE POLYUREA (6", 20 mils)
V34	2' - 6' SP YELLOW MINISKIP POLYUREA (6", 20 mils)
V40	WHITE GORE LINE POLYUREA (8", 20 mils)
PAVEMENT MARKING SYMBOLS	
T70	LEFT TURN ARROW THERMOPLASTIC
T71	RIGHT TURN ARROW THERMOPLASTIC
T72	STRAIGHT ARROW THERMOPLASTIC
T74	COMBO STRAIGHT / RIGHT ARROW THERMOPLASTIC
T81	ELONGATED RAMP ARROW THERMOPLASTIC
T100	ALPHANUMERIC CHARACTER THERMOPLASTIC
PAVEMENT MARKERS	
ME	YELLOW AND YELLOW PERMANENT SNOWPLOWABLE
MF	CRYSTAL AND RED PERMANENT SNOWPLOWABLE

- 1 -LPC- STA 19+01 +/-
- 2 -LPC- STA 19+20 +/-
- 3 -RPC- STA. 26+67 +/- (T61)
- 4 -Y2- STA 41+16 +/-
- 5 -Y2- STA 41+66 +/-

2610 WYCLIFF ROAD  
SUITE 410  
RALEIGH, NC 27607  
PHONE: 919-881-9939  
NC COA No. F-0929

**PAVEMENT MARKING DETAIL**

16-APR-2020 10:42  
 P:\500715\20\CAD\CIVIL\N-2233BB\Traffic\Plans\R2233BB\_PMP\_PMP\_26.dgn  
 JTB

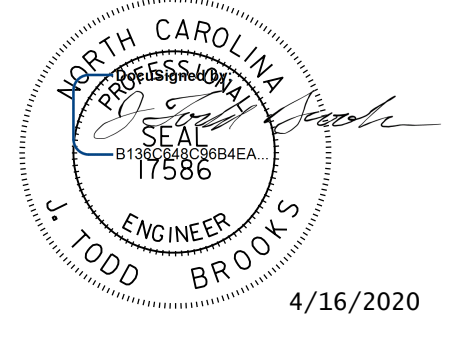
TIP NO. R-2233BB	SHEET NO. PMP - 27
APPROVED: _____	
DATE: _____	
SEAL	
	
DOCUMENT NOT CONSIDERED FINAL UNLESS ALL SIGNATURES COMPLETED	

NO PROPOSED MARKINGS THIS SHEET

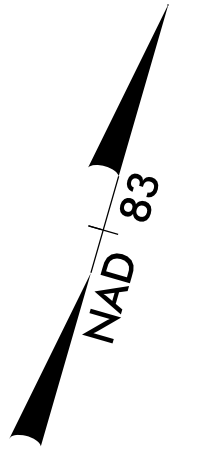

5

10

15

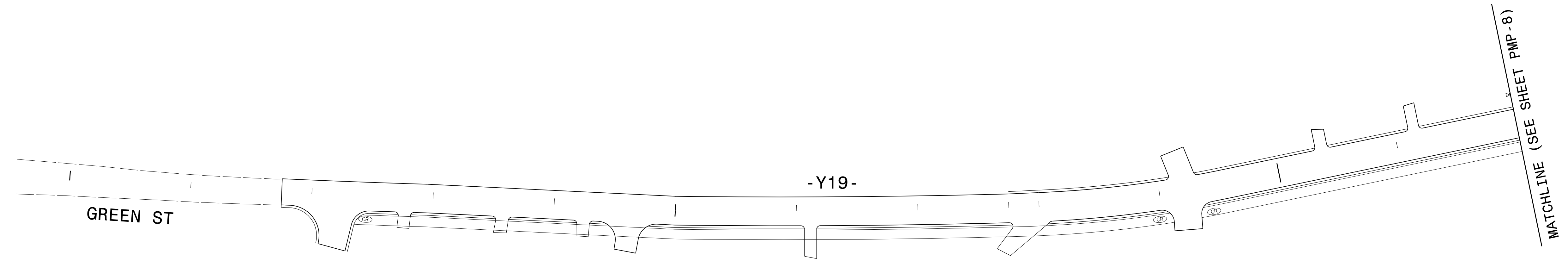

I6-APP-2020\_1042  
P:\50075420\CAD\Civil\N-2233BB\Tr of fig\PM\Plans\R2233BB\_PMP\_PMP\_27.dgn  
JTB



2610 WYCLIFF ROAD  
SUITE 410  
RALEIGH, NC 27607  
PHONE: 919-881-9939  
NC COA No. F-0929

PAVEMENT MARKING DETAIL

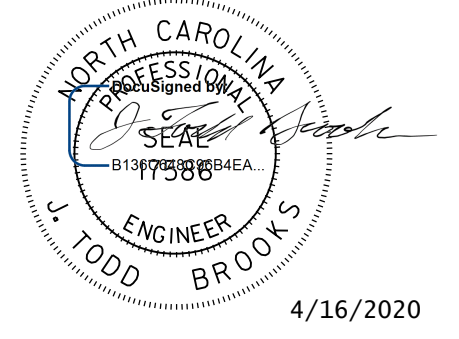

TIP NO. R-2233BB	SHEET NO. PMP-28
APPROVED: _____	
DATE: _____	
SEAL	
	
DOCUMENT NOT CONSIDERED FINAL UNLESS ALL SIGNATURES COMPLETED	

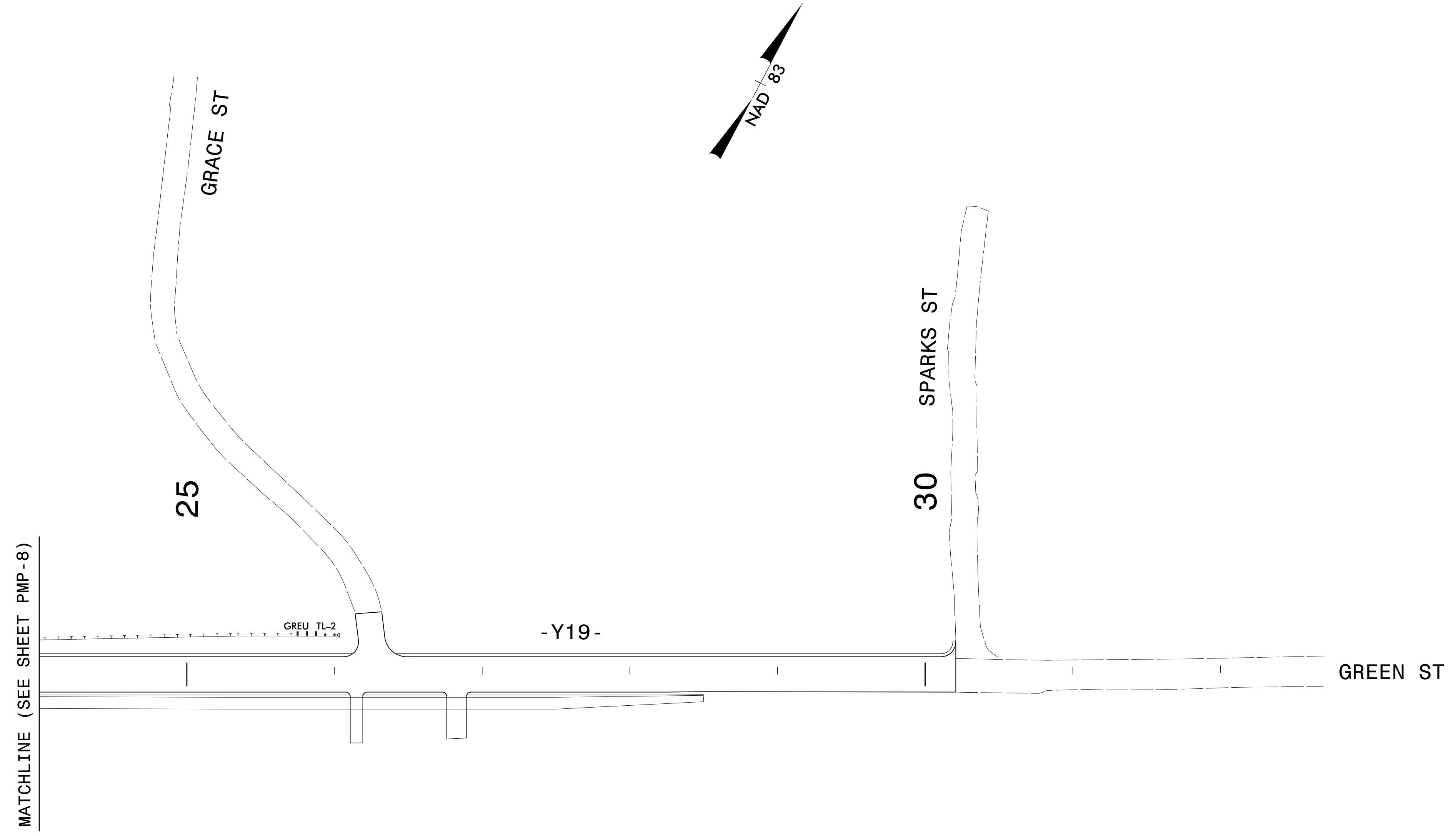

NO PROPOSED MARKINGS THIS SHEET

I6-APP-2020\_1042  
P:\50075420\CAD\CIVIL\N-2233BB\Tr of fig\PM\Plans\R2233BB\_PMP\_PMP\_28.dgn  
JTB



2610 WYCLIFF ROAD  
SUITE 410  
RALEIGH, NC 27607  
PHONE: 919-881-9939  
NC COA No. F-0929

**PAVEMENT MARKING DETAIL**

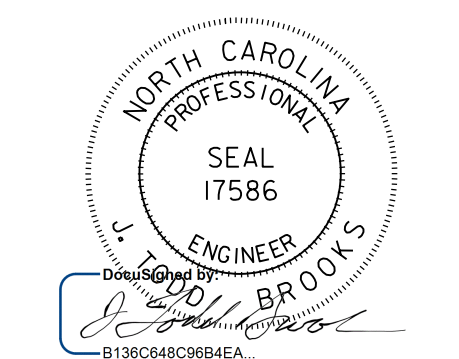
TIP NO. R-2233BB	SHEET NO. PMP - 29
APPROVED: _____	
DATE: _____	
SEAL	
	
<b>DOCUMENT NOT CONSIDERED FINAL UNLESS ALL SIGNATURES COMPLETED</b>	

1 05/02/2022 ROADWAY PLAN REVISIONS

SEE INSET THIS SHEET FOR ADDITIONAL LABELS

13-XXXX SIGNAL INVENTORY NUMBER

SEE SIGNAL PLANS FOR FINAL STOP BAR LOCATIONS

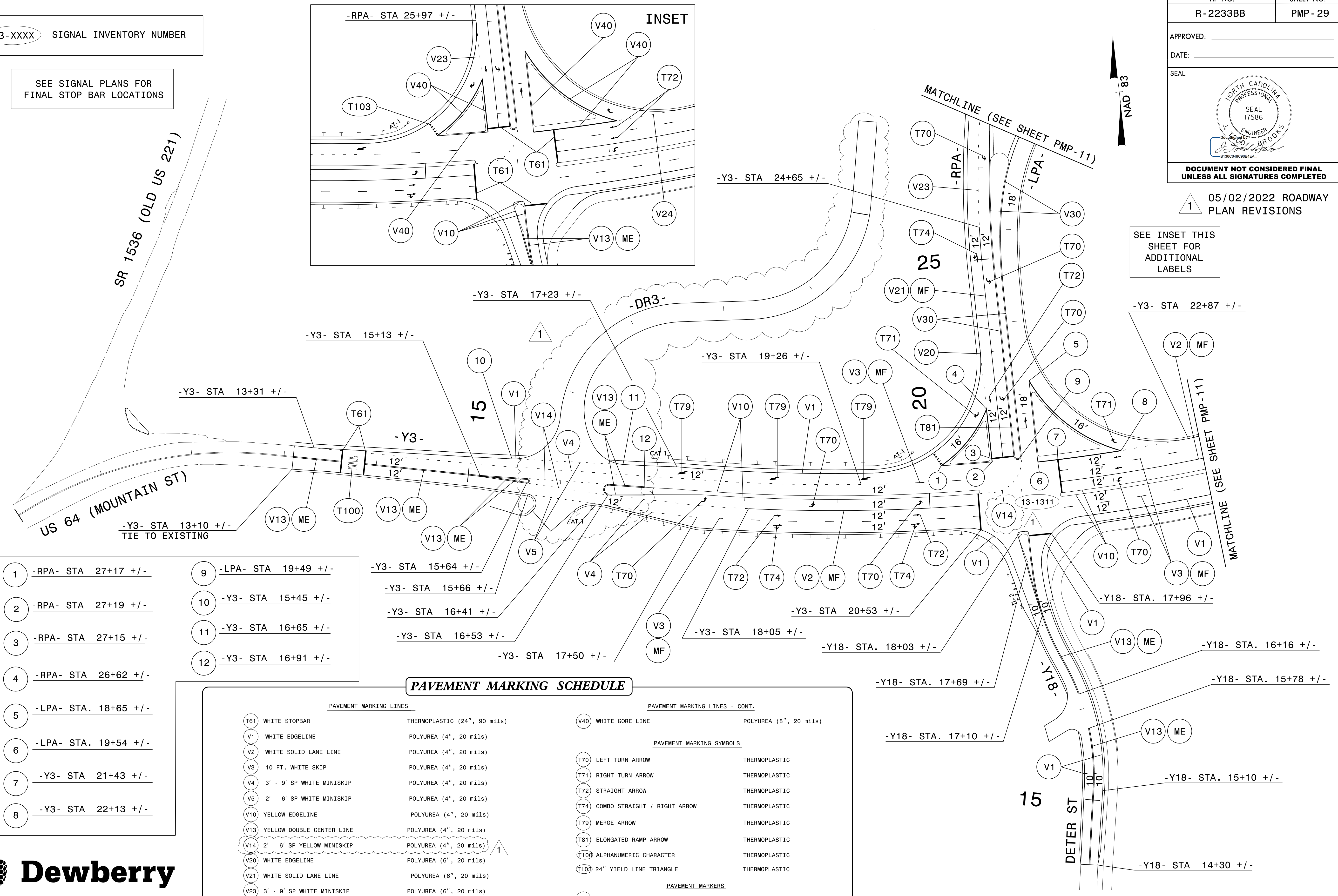

- 1 -RPA- STA 27+17 +/-
- 2 -RPA- STA 27+19 +/-
- 3 -RPA- STA 27+15 +/-
- 4 -RPA- STA 26+62 +/-
- 5 -LPA- STA. 18+65 +/-
- 6 -LPA- STA. 19+54 +/-
- 7 -Y3- STA 21+43 +/-
- 8 -Y3- STA 22+13 +/-
- 9 -LPA- STA 19+49 +/-
- 10 -Y3- STA 15+45 +/-
- 11 -Y3- STA 16+65 +/-
- 12 -Y3- STA 16+91 +/-
- Y3- STA 15+64 +/-
- Y3- STA 15+66 +/-
- Y3- STA 16+41 +/-
- Y3- STA 16+53 +/-
- Y3- STA 17+50 +/-
- Y3- STA 15+13 +/-
- Y3- STA 13+31 +/-
- Y3- STA 13+10 +/- TIE TO EXISTING
- Y3- STA 17+23 +/-
- Y3- STA 19+26 +/-
- Y3- STA 20+53 +/-
- Y18- STA. 18+03 +/-
- Y18- STA. 17+69 +/-
- Y18- STA. 17+10 +/-
- Y18- STA. 17+96 +/-
- Y18- STA. 16+16 +/-
- Y18- STA. 15+78 +/-
- Y18- STA. 15+10 +/-
- Y18- STA 14+30 +/-

**PAVEMENT MARKING SCHEDULE**

PAVEMENT MARKING LINES		PAVEMENT MARKING LINES - CONT.	
T61	WHITE STOPBAR	THERMOPLASTIC (24", 90 mils)	
V1	WHITE EDGELINE	POLYUREA (4", 20 mils)	
V2	WHITE SOLID LANE LINE	POLYUREA (4", 20 mils)	
V3	10 FT. WHITE SKIP	POLYUREA (4", 20 mils)	
V4	3' - 9" SP WHITE MINISKIP	POLYUREA (4", 20 mils)	
V5	2' - 6" SP WHITE MINISKIP	POLYUREA (4", 20 mils)	
V10	YELLOW EDGELINE	POLYUREA (4", 20 mils)	
V13	YELLOW DOUBLE CENTER LINE	POLYUREA (4", 20 mils)	
V14	2' - 6" SP YELLOW MINISKIP	POLYUREA (4", 20 mils)	
V20	WHITE EDGELINE	POLYUREA (6", 20 mils)	
V21	WHITE SOLID LANE LINE	POLYUREA (6", 20 mils)	
V23	3' - 9" SP WHITE MINISKIP	POLYUREA (6", 20 mils)	
V24	2' - 6" SP WHITE MINISKIP	POLYUREA (6", 20 mils)	
V30	YELLOW EDGELINE	POLYUREA (6", 20 mils)	
V34	2' - 6" SP YELLOW MINISKIP	POLYUREA (6", 20 mils)	
V40	WHITE GORE LINE	POLYUREA (8", 20 mils)	
PAVEMENT MARKING SYMBOLS			
T70	LEFT TURN ARROW	THERMOPLASTIC	
T71	RIGHT TURN ARROW	THERMOPLASTIC	
T72	STRAIGHT ARROW	THERMOPLASTIC	
T74	COMBO STRAIGHT / RIGHT ARROW	THERMOPLASTIC	
T79	MERGE ARROW	THERMOPLASTIC	
T81	ELONGATED RAMP ARROW	THERMOPLASTIC	
T100	ALPHANUMERIC CHARACTER	THERMOPLASTIC	
T103	24" YIELD LINE TRIANGLE	THERMOPLASTIC	
PAVEMENT MARKERS			
ME	YELLOW AND YELLOW	PERMANENT SNOWPLOWABLE	
MF	CRYSTAL AND RED	PERMANENT SNOWPLOWABLE	

**PAVEMENT MARKING DETAIL**

02-MAY-2022 16:57  
 P:\50075420\CAD\CIVIL\NR-2233BB\Trg\fig\pmp\Plans\R2233BB\_PMP\_PMP\_29.dgn  
 AT R90K8AV4  
 dbeshed@s



2610 WYCLIFF ROAD  
SUITE 410  
RALEIGH, NC 27607  
PHONE: 919-881-9939  
NC COA No. F-0929



APPROVED: \_\_\_\_\_  
 DATE: \_\_\_\_\_

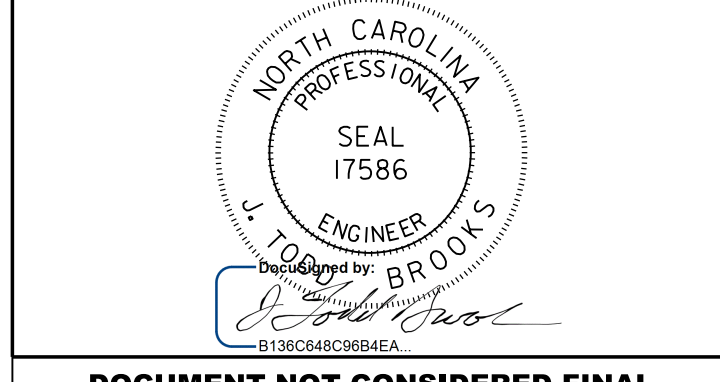

**DOCUMENT NOT CONSIDERED FINAL UNLESS ALL SIGNATURES COMPLETED**

- 1 05/02/2022 ROADWAY PLAN REVISIONS
- 2 05/02/2022 REVISED LINE STYLE

**PAVEMENT MARKING SCHEDULE**

PAVEMENT MARKING LINES		PAVEMENT MARKING SYMBOLS	
T61	WHITE STOPBAR	T70	LEFT TURN ARROW
T62	WHITE CROSSWALK LINE	T71	RIGHT TURN ARROW
V1	WHITE EDGELINE	T72	STRAIGHT ARROW
V2	WHITE SOLID LANE LINE	T73	COMBO STRAIGHT / LEFT ARROW
V3	10 FT. WHITE SKIP	T74	COMBO STRAIGHT / RIGHT ARROW
V4	3' - 9' SP WHITE MINISKIP	T80	WRONG WAY RAMP ARROW
V10	YELLOW EDGELINE	T81	ELONGATED RAMP ARROW
V13	YELLOW DOUBLE CENTER LINE	T100	ALPHANUMERIC CHARACTER
V20	WHITE EDGELINE	T103	24" YIELD LINE TRIANGLE
V21	WHITE SOLID LANE LINE		
V23	3' - 9' SP WHITE MINISKIP	ME	YELLOW AND YELLOW PERMANENT SNOWPLOWABLE
V30	YELLOW EDGELINE	MF	CRYSTAL AND RED PERMANENT SNOWPLOWABLE
V34	2' - 6' SP YELLOW MINISKIP		
V40	WHITE GORE LINE		
V44	3' - 9' SP WHITE MINISKIP		

13-XXXX SIGNAL INVENTORY NUMBER

SEE SIGNAL PLANS FOR FINAL STOP BAR LOCATIONS

SEE INSET THIS SHEET FOR ADDITIONAL LABELS

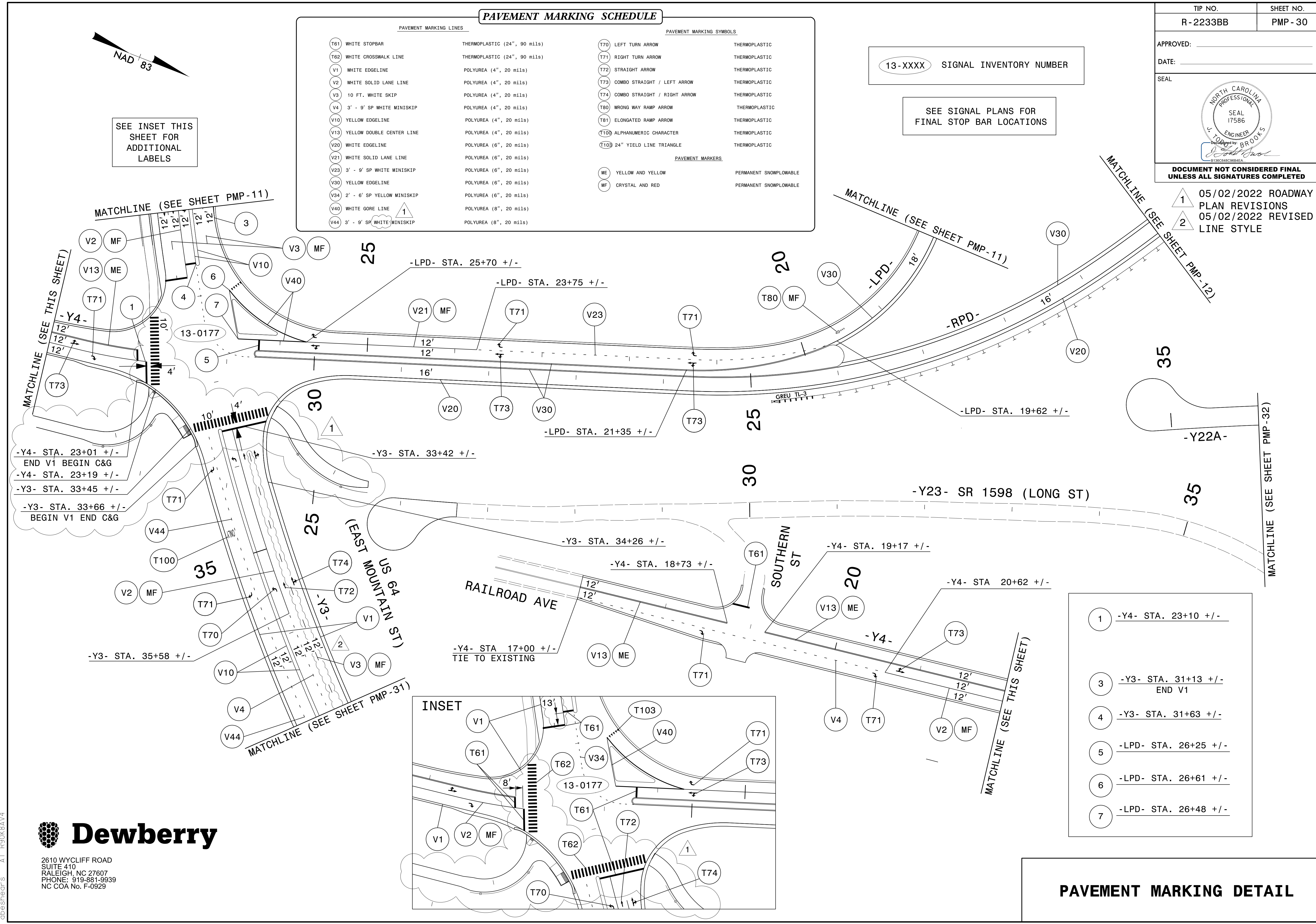

-Y4- STA. 23+01 +/-  
 END V1 BEGIN C&G  
 -Y4- STA. 23+19 +/-  
 -Y3- STA. 33+45 +/-  
 -Y3- STA. 33+66 +/-  
 BEGIN V1 END C&G

-Y3- STA. 35+58 +/-

-Y3- STA. 33+42 +/-

-LPD- STA. 21+35 +/-

-Y3- STA. 34+26 +/-

-Y4- STA. 18+73 +/-

-Y4- STA. 17+00 +/-  
 TIE TO EXISTING

-Y4- STA. 19+17 +/-

-Y4- STA. 20+62 +/-

1 -Y4- STA. 23+10 +/-

3 -Y3- STA. 31+13 +/-  
 END V1

4 -Y3- STA. 31+63 +/-

5 -LPD- STA. 26+25 +/-

6 -LPD- STA. 26+61 +/-

7 -LPD- STA. 26+48 +/-

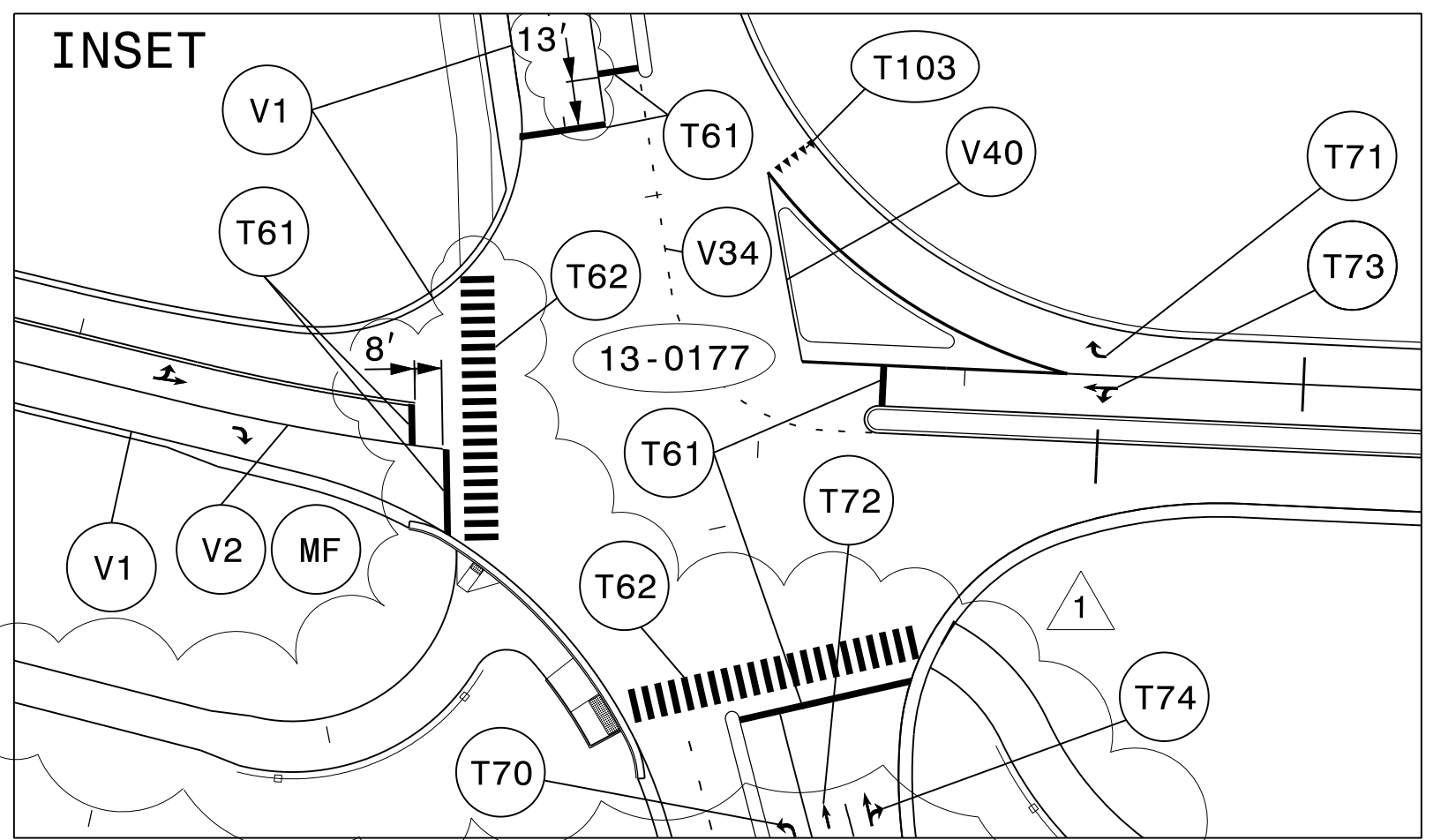

**PAVEMENT MARKING DETAIL**



2610 WYCLIFF ROAD  
 SUITE 410  
 RALEIGH, NC 27607  
 PHONE: 919-881-9939  
 NC COA No. F-0929

02-MAY-2022 16:57  
 P:\50075420\CAD\Projects\R22333BB\Traffic\Plans\R22333BB\_PMP\_PMP\_30.dgn  
 AT R90K8AV4  
 dbeshed@s

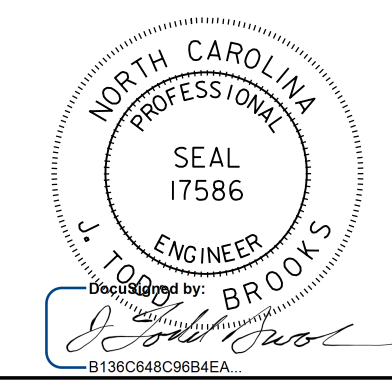
TIP NO. R-2233BB	SHEET NO. PMP-31
APPROVED: _____	
DATE: _____	
SEAL	
	
<b>DOCUMENT NOT CONSIDERED FINAL UNLESS ALL SIGNATURES COMPLETED</b>	

1 05/02/2022 REVISED  
LINE STYLE

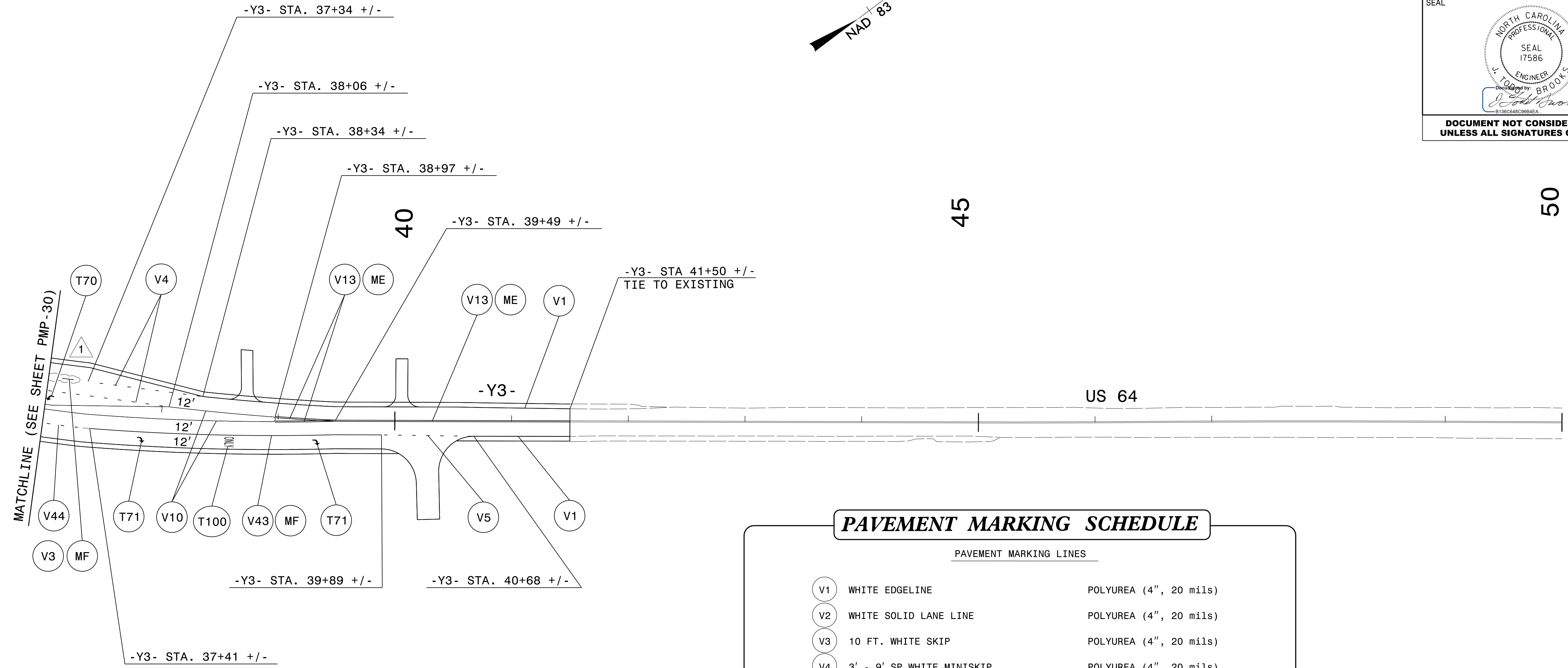
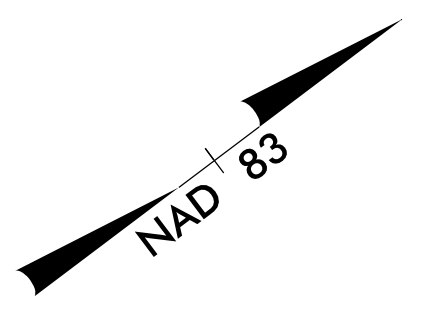

**PAVEMENT MARKING SCHEDULE**

PAVEMENT MARKING LINES		
V1	WHITE EDGELINE	POLYUREA (4", 20 mils)
V2	WHITE SOLID LANE LINE	POLYUREA (4", 20 mils)
V3	10 FT. WHITE SKIP	POLYUREA (4", 20 mils)
V4	3' - 9' SP WHITE MINISKIP	POLYUREA (4", 20 mils)
V5	3' - 9' SP WHITE MINISKIP	POLYUREA (4", 20 mils)
V10	YELLOW EDGELINE	POLYUREA (4", 20 mils)
V13	YELLOW DOUBLE CENTER LINE	POLYUREA (4", 20 mils)
V43	WHITE SOLID LANE LINE	POLYUREA (8", 20 mils)
V44	3' - 9' SP WHITE MINISKIP	POLYUREA (8", 20 mils)
PAVEMENT MARKING SYMBOLS		
T70	LEFT TURN ARROW	THERMOPLASTIC
T71	RIGHT TURN ARROW	THERMOPLASTIC
T100	ALPHANUMERIC CHARACTER	THERMOPLASTIC
PAVEMENT MARKERS		
MF	CRYSTAL AND RED	PERMANENT SNOWFLOWABLE
ME	YELLOW AND YELLOW	PERMANENT SNOWFLOWABLE

**PAVEMENT MARKING DETAIL**

02-MAY-2022 16:57  
 P:\50075420\CAD\CIVIL\NR-2233BB\Tr of fic\MP\Plans\2233BB\_PMP\_PMP\_31.dgn  
 AT R90K8AV4  
 abeshed@s



2610 WYCLIFF ROAD  
 SUITE 410  
 RALEIGH, NC 27607  
 PHONE: 919-881-9939  
 NC COA No. F-0929

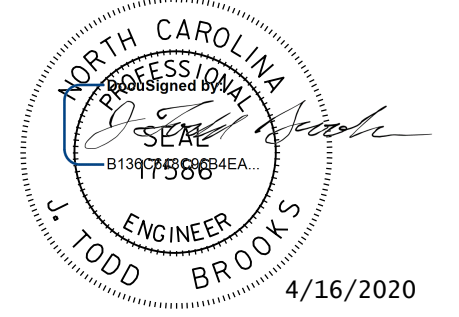

APPROVED: \_\_\_\_\_  
 DATE: \_\_\_\_\_

SEAL  
  
 J. TODD BROOKS  
 4/16/2020

**DOCUMENT NOT CONSIDERED FINAL  
 UNLESS ALL SIGNATURES COMPLETED**

### PAVEMENT MARKING SCHEDULE

PAVEMENT MARKING LINES		
T62	WHITE CROSSWALK LINE	THERMOPLASTIC (24", 90 mils)
V1	WHITE EDGELINE	POLYUREA (4", 20 mils)
V13	YELLOW DOUBLE CENTER LINE	POLYUREA (4", 20 mils)
PAVEMENT MARKERS		
ME	YELLOW AND YELLOW	PERMANENT SNOWPLOWABLE

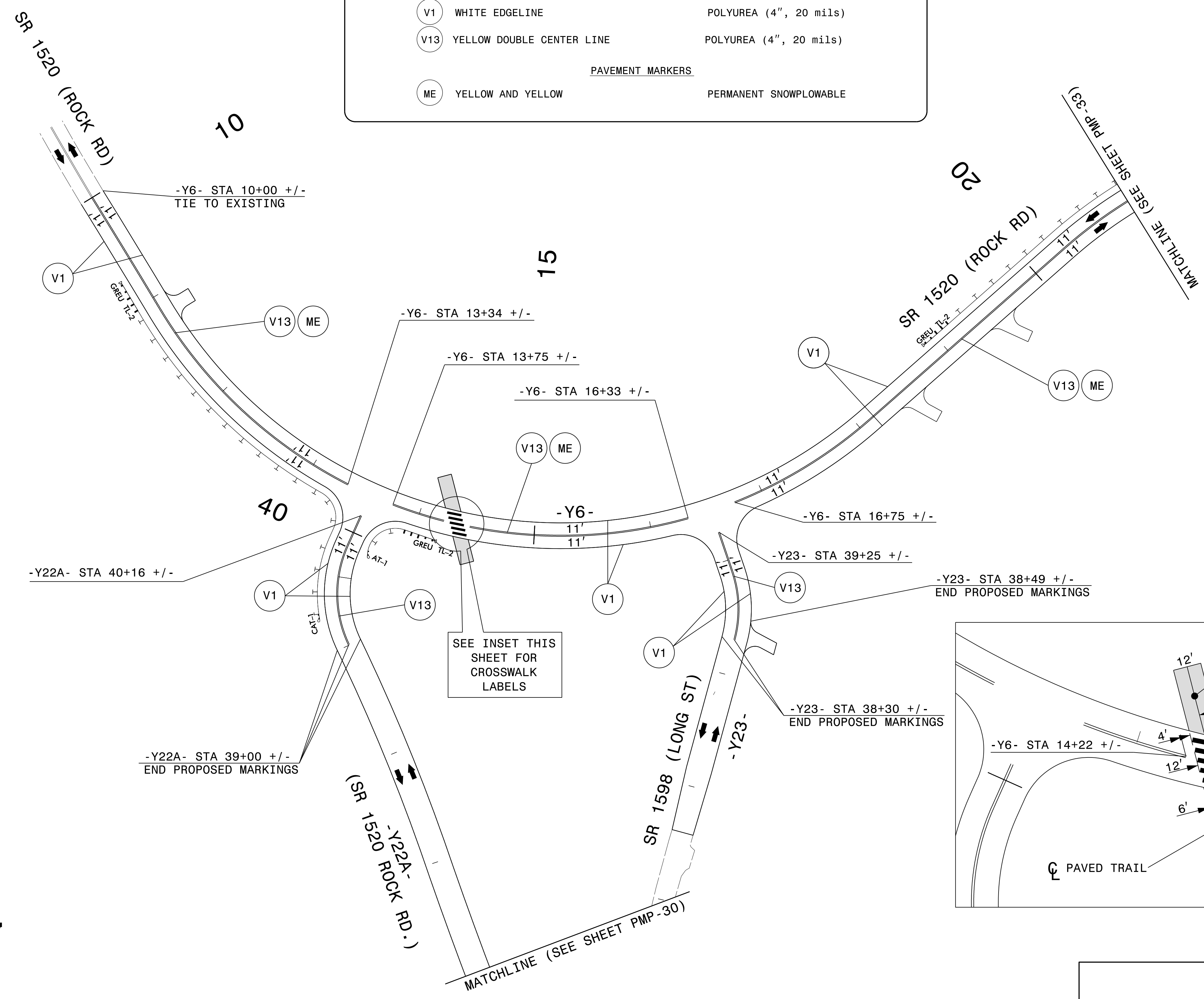
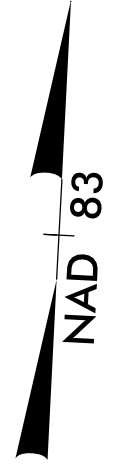

SEE INSET THIS SHEET FOR CROSSWALK LABELS

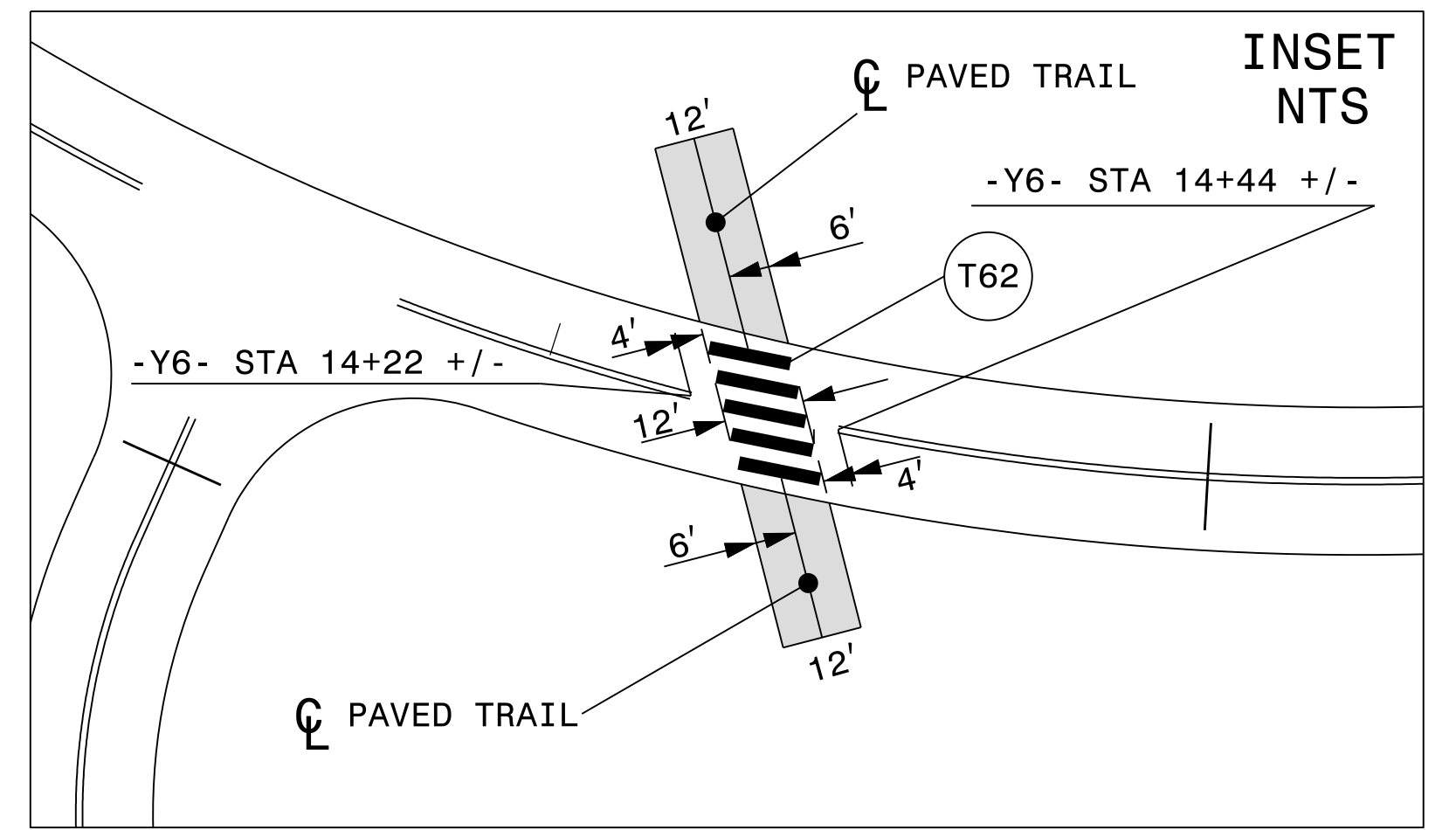

**PAVEMENT MARKING DETAIL**

I6-APP-2020\_1042  
 P:\50075420\CAD\CIVIL\N-2233BB\Plans\R2233BB\_PMP\_PMP\_32.dgn  
 JTB  
 4/16/20



2610 WYCLIFF ROAD  
 SUITE 410  
 RALEIGH, NC 27607  
 PHONE: 919-881-9939  
 NC COA No. F-0929

APPROVED: \_\_\_\_\_  
 DATE: \_\_\_\_\_

SEAL

4/16/2020

**DOCUMENT NOT CONSIDERED FINAL  
UNLESS ALL SIGNATURES COMPLETED**

### PAVEMENT MARKING SCHEDULE

PAVEMENT MARKING LINES

- V1 WHITE EDGELINE POLYUREA (4", 20 mils)
- V5 2' - 6' SP WHITE MINISKIP POLYUREA (4", 20 mils)
- V13 YELLOW DOUBLE CENTER LINE POLYUREA (4", 20 mils)

PAVEMENT MARKERS

- ME YELLOW AND YELLOW PERMANENT SNOWPLOWABLE

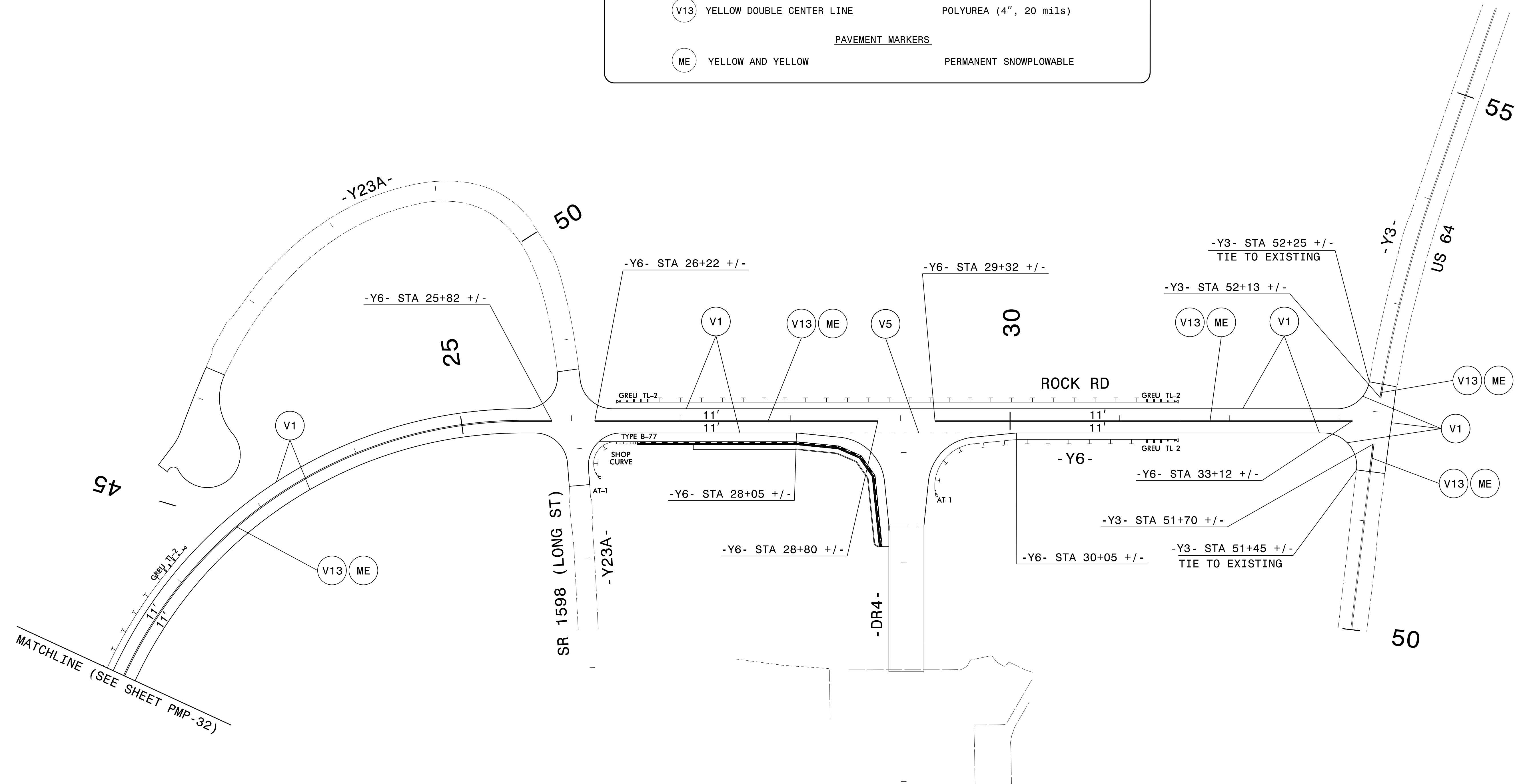
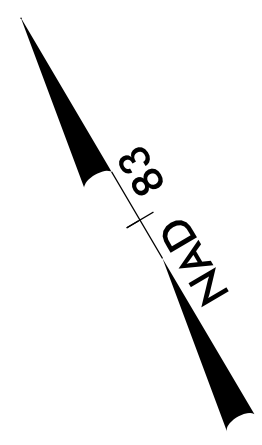

I6-APP-2020\_1042  
 P:\50075420\CAD\CIVIL\N-2233BB\Tr of fig\PM\Plans\R2233BB\_PMP\_PMP\_33.dgn  
 JTB  
 AT PC0036KJ



2610 WYCLIFF ROAD  
 SUITE 410  
 RALEIGH, NC 27607  
 PHONE: 919-881-9939  
 NC COA No. F-0929

**PAVEMENT MARKING DETAIL**

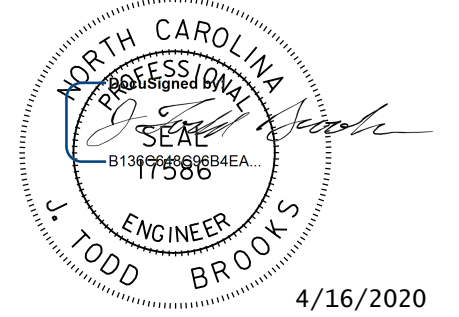

TIP NO. R-2233BB	SHEET NO. PMP-34
APPROVED: _____	
DATE: _____	
SEAL	
	
4/16/2020	
DOCUMENT NOT CONSIDERED FINAL UNLESS ALL SIGNATURES COMPLETED	

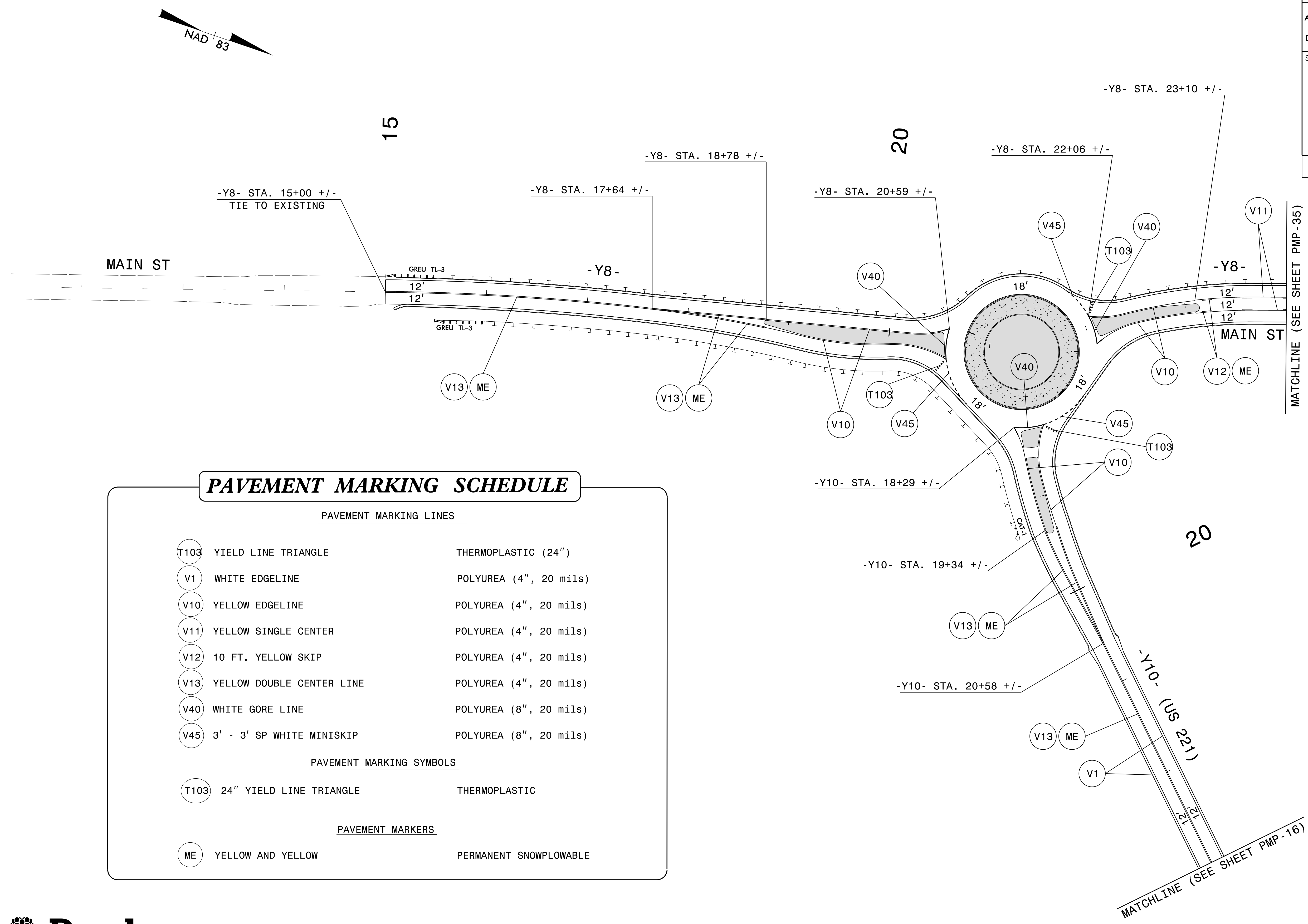

**PAVEMENT MARKING SCHEDULE**

PAVEMENT MARKING LINES

(T103)	YIELD LINE TRIANGLE	THERMOPLASTIC (24")
(V1)	WHITE EDGELINE	POLYUREA (4", 20 mils)
(V10)	YELLOW EDGELINE	POLYUREA (4", 20 mils)
(V11)	YELLOW SINGLE CENTER	POLYUREA (4", 20 mils)
(V12)	10 FT. YELLOW SKIP	POLYUREA (4", 20 mils)
(V13)	YELLOW DOUBLE CENTER LINE	POLYUREA (4", 20 mils)
(V40)	WHITE GORE LINE	POLYUREA (8", 20 mils)
(V45)	3' - 3' SP WHITE MINISKIP	POLYUREA (8", 20 mils)

PAVEMENT MARKING SYMBOLS

(T103)	24" YIELD LINE TRIANGLE	THERMOPLASTIC
--------	-------------------------	---------------

PAVEMENT MARKERS

(ME)	YELLOW AND YELLOW	PERMANENT SNOWPLOWABLE
------	-------------------	------------------------

I6-APP-2020\_10h2  
 P:\50075\20\CAD\Civil\N-2233BB\Tr of fic\PM\Plans\R2233BB\_PMP\_PMP\_34.dgn  
 JTB



2610 WYCLIFF ROAD  
 SUITE 410  
 RALEIGH, NC 27607  
 PHONE: 919-881-9939  
 NC COA No. F-0929

**PAVEMENT MARKING DETAIL**

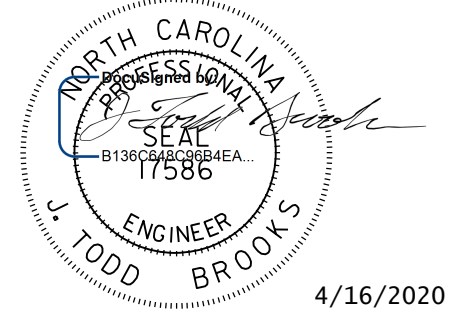
TIP NO. R-2233BB	SHEET NO. PMP-35
APPROVED: _____	
DATE: _____	
SEAL	
	
4/16/2020	
DOCUMENT NOT CONSIDERED FINAL UNLESS ALL SIGNATURES COMPLETED	

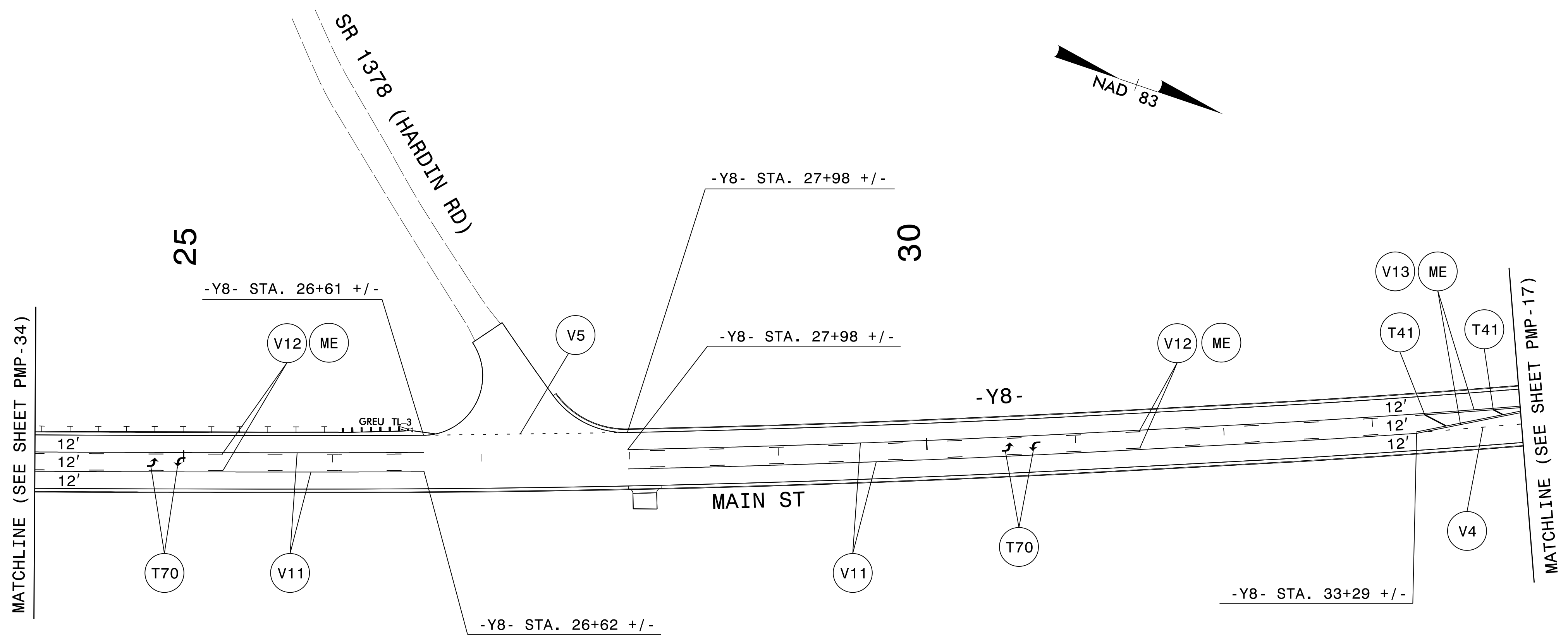

### PAVEMENT MARKING SCHEDULE

#### PAVEMENT MARKING LINES

(T41)	WHITE DIAGONAL	THERMOPLASTIC (8", 90 mils)
(V4)	3' - 9' SP WHITE MINISKIP	POLYUREA (4", 20 mils)
(V5)	2' - 6' SP WHITE MINISKIP	POLYUREA (4", 20 mils)
(V11)	YELLOW SINGLE CENTER	POLYUREA (4", 20 mils)
(V12)	10 FT. YELLOW SKIP	POLYUREA (4", 20 mils)
(V13)	YELLOW DOUBLE CENTER LINE	POLYUREA (4", 20 mils)

#### PAVEMENT MARKING SYMBOLS

(T70)	LEFT TURN ARROW	THERMOPLASTIC
-------	-----------------	---------------

#### PAVEMENT MARKERS

(ME)	YELLOW AND YELLOW	PERMANENT SNOWPLOWABLE
------	-------------------	------------------------

I6-APP-2020\_1042  
 P:\50075\20\CAD\Civil\N-2233BB\Tr of fig\PMP\Plans\R2233BB\_PMP\_PMP\_35.dgn  
 JTB



2610 WYCLIFF ROAD  
 SUITE 410  
 RALEIGH, NC 27607  
 PHONE: 919-881-9939  
 NC COA No. F-0929

PAVEMENT MARKING DETAIL



TIP NO. R-2233BB	SHEET NO. PMP-36
APPROVED: _____	
DATE: _____	
SEAL	
<b>DOCUMENT NOT CONSIDERED FINAL UNLESS ALL SIGNATURES COMPLETED</b>	

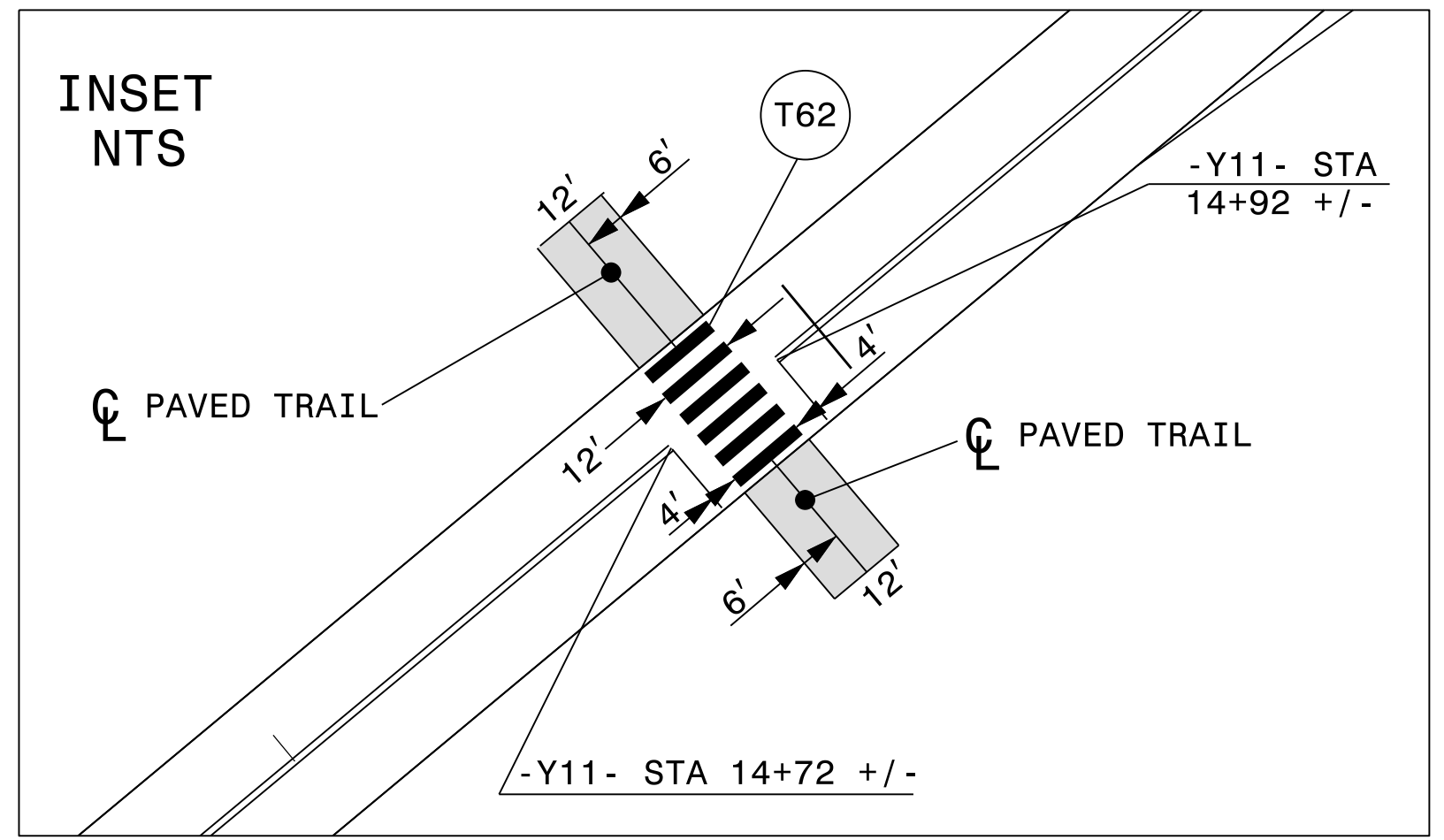

20

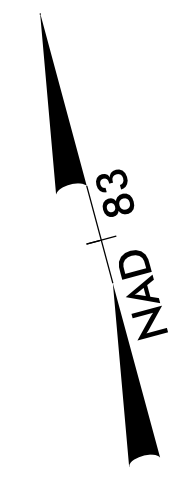

25

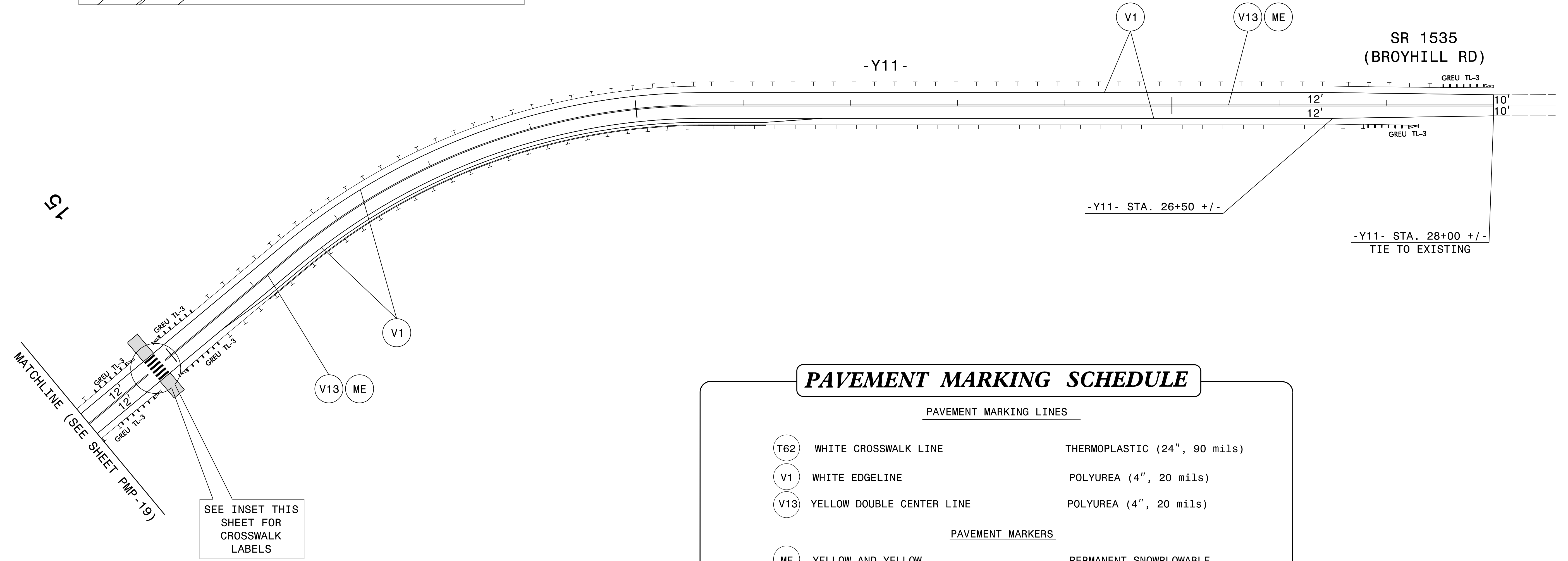

### PAVEMENT MARKING SCHEDULE

PAVEMENT MARKING LINES

- |       |                           |                              |
|-------|---------------------------|------------------------------|
| (T62) | WHITE CROSSWALK LINE      | THERMOPLASTIC (24", 90 mils) |
| (V1)  | WHITE EDGELINE            | POLYUREA (4", 20 mils)       |
| (V13) | YELLOW DOUBLE CENTER LINE | POLYUREA (4", 20 mils)       |

PAVEMENT MARKERS

- |      |                   |                        |
|------|-------------------|------------------------|
| (ME) | YELLOW AND YELLOW | PERMANENT SNOWPLOWABLE |
|------|-------------------|------------------------|

SEE INSET THIS SHEET FOR CROSSWALK LABELS



2610 WYCLIFF ROAD  
SUITE 410  
RALEIGH, NC 27607  
PHONE: 919-881-9939  
NC COA No. F-0929

**PAVEMENT MARKING DETAIL**

I6-APP-2020\_1042  
P:\50075420\CAD\CIVIL\N-2233BB\Tr of fig\PM\Plans\N-2233BB\_PMP\_PMP\_36.dgn  
AT PC0036KJ