

09\_08/2019

TIP PROJECT: R-2233BB

CONTRACT: C204397

See Sheet 1A For Index of Sheets  
See Sheet 1B For Conventional Symbols

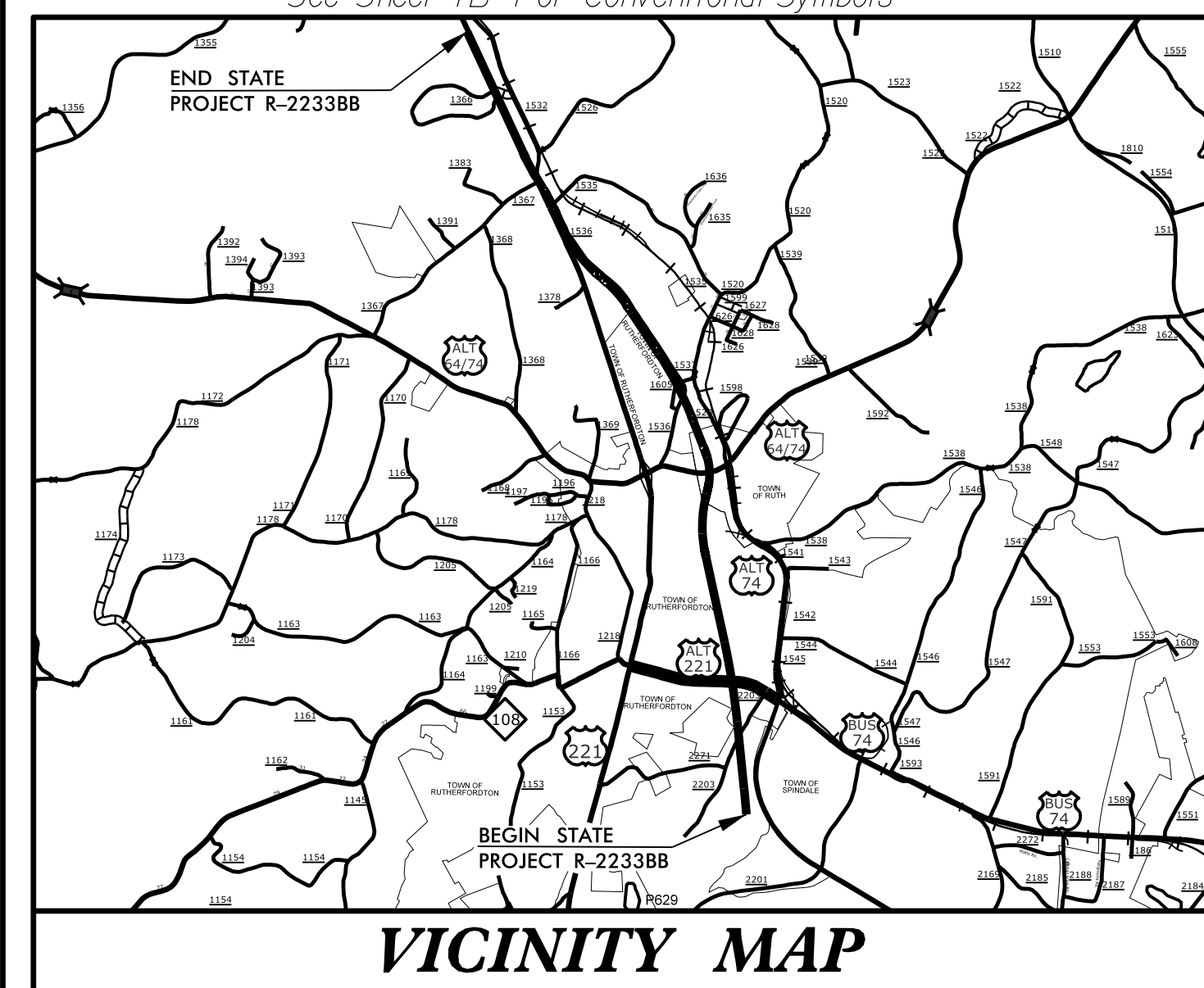

# STATE OF NORTH CAROLINA DIVISION OF HIGHWAYS RUTHERFORD COUNTY

LOCATION: US 221 SOUTH OF US 74 BUSINESS (CHARLOTTE ROAD)  
TO NORTH OF SR 1366 (ROPER LOOP ROAD)

TYPE OF WORK: GRADING, DRAINAGE, PAVING, RETAINING WALL  
AND STRUCTURES

STATE	STATE PROJECT REFERENCE NO.	SHEET NO.	TOTAL SHEETS
N.C.	R-2233BB	1	
STATE PROJ. NO.	F.A. PROJ. NO.	DESCRIPTION	
34400.1.S5		PE	
34400.2.5		RW	
34400.2.7		UTIL.	
34400.3.4		CONST.	

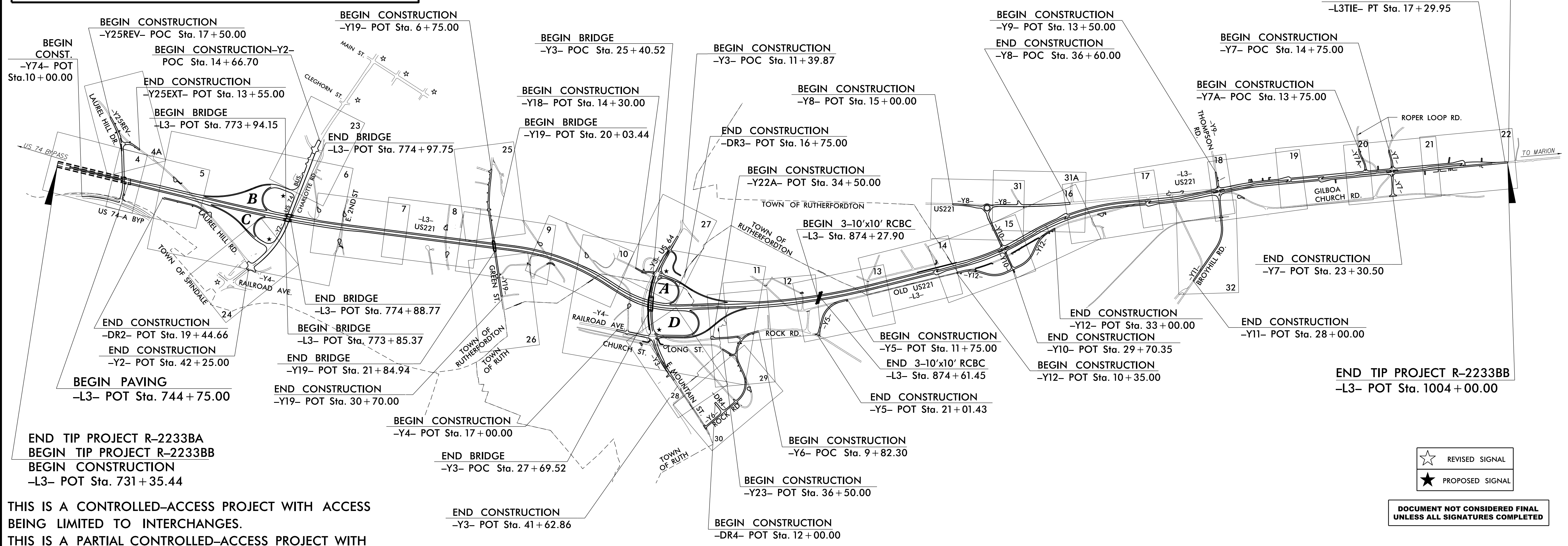

THIS IS A CONTROLLED-ACCESS PROJECT WITH ACCESS BEING LIMITED TO INTERCHANGES.  
THIS IS A PARTIAL CONTROLLED-ACCESS PROJECT WITH ACCESS BEING LIMITED TO POINTS AS SHOWN ON THE PLANS.

☆ REVISED SIGNAL  
★ PROPOSED SIGNAL

DOCUMENT NOT CONSIDERED FINAL  
UNLESS ALL SIGNATURES COMPLETED

NCDOT CONTACT: NATHAN ADIMA, P.E.

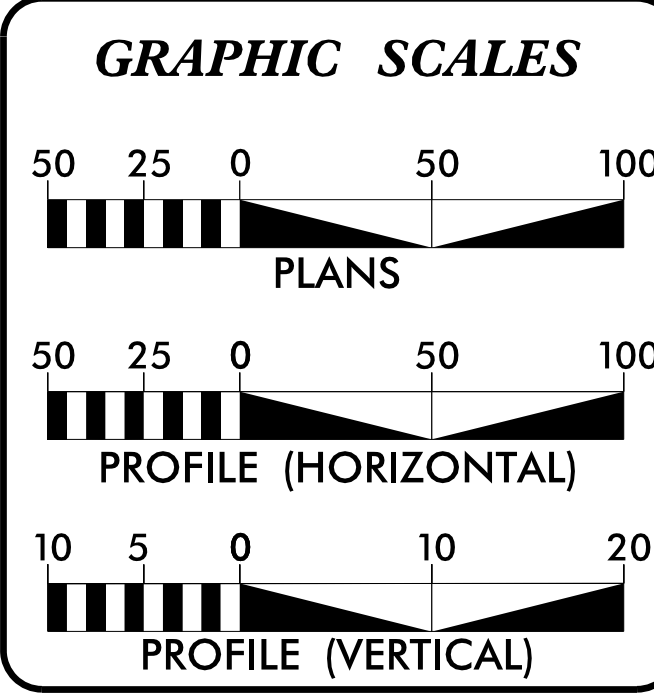

**DESIGN DATA**

ADT 2020 =	13300
ADT 2040 =	14500
K =	9 %
D =	60 %
T =	9 % *
V =	70 MPH
* TTST	5% DUAL 4%
FUNC CLASS =	ARTERIAL
REGIONAL	TIER

**PROJECT LENGTH**

LENGTH ROADWAY TIP PROJECT R-2233BB =	5.138 MILES
LENGTH STRUCTURE TIP PROJECT R-2233BB =	0.026 MILES
TOTAL LENGTH TIP PROJECT R-2233BB =	5.164 MILES

STRUCTURE LENGTH BASED ON -L3- NB STATIONING.

PLANS PREPARED FOR NCDOT BY:

**Dewberry**  
2610 WYCLIFF ROAD  
SUITE 410  
RALEIGH, NC 27607  
PHONE: 919.881.9939  
NC COA No. F-0929

2018 STANDARD SPECIFICATIONS

RIGHT OF WAY DATE: JULY 28, 2017

LETTING DATE: DECEMBER 21, 2021

DENNIS J. MORY, P.E.  
PROJECT ENGINEER

BRYAN LAMBETH, P.E.  
PROJECT DESIGN ENGINEER

HYDRAULICS ENGINEER

9/10/2021

DocuSigned by:  
Steven M. Bandler  
SIGNATURE: Steven M. Bandler

ROADWAY DESIGN ENGINEER

9/10/2021

DocuSigned by:  
Dennis J. Mory, PE  
SIGNATURE: Dennis J. Mory, PE

Professional Engineer Seals for Steven M. Bandler and Dennis J. Mory, PE.

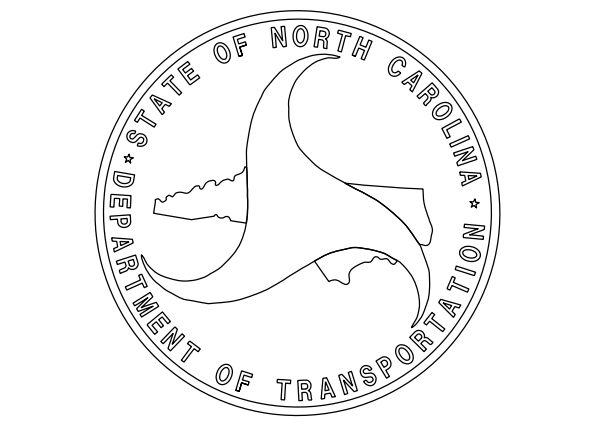



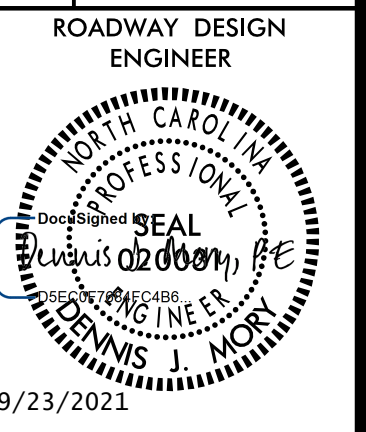

**DOCUMENT NOT CONSIDERED FINAL  
UNLESS ALL SIGNATURES COMPLETED**

TIP: R-2233BB	INDEX OF SHEETS
SHEET NUMBER	SHEET
1	TITLE SHEET
1A	INDEX OF SHEETS, GENERAL NOTES, AND LIST OF STANDARD DRAWINGS
1B	CONVENTIONAL SYMBOLS
2A-1 THRU 2A-9	PAVEMENT SCHEDULE, TYPICAL SECTIONS, AND PAVEMENT WEDGE DETAILS
2B-1 THRU 2B-8	INTERSECTION AND BULB OUT DETAIL SHEETS
2B-9 THRU 2B-10	SHEAR POINT LAYOUT
2B-11 THRU 2B-12	DETOUR DETAIL SHEETS
2C-1 THRU 2C-17	DETAIL OF TYPE III BRIDGE APPROACH FILLS DETAIL OF GUARDRAIL TYPE III ANCHOR UNITS DETAIL OF W-BEAM RAIL SECTION DETAIL OF CABLE GUIDERAIL TREATMENT AT MEDIAN HAZARDS DETAIL OF GUARDRAIL AT-1 END UNIT DETAIL OF COAL COMBUSTION PRODUCT PLACEMENT DETAIL OF STEEL BOLLARDS DETAIL OF BIKE & PEDESTRIAN SAFETY RAIL DETAIL OF GUIDE FOR BERM DRAINAGE OUTLET FOR 36" PIPE DETAIL OF SPECIAL DROP INLET 840D14 FOR 60" PIPE DETAIL OF MINIMUM DEPTH CONCRETE CATCH BASIN DETAIL OF SINGLE SLOPE CONCRETE BARRIER (-Y3- OMVT) DETAIL OF DROP INLETS IN CONCRETE ISLAND DETAIL OF CURB RAMPS IN CONCRETE ISLAND DETAIL OF EXTRA DEPTH CONCRETE CATCH BASIN 12" THRU 84" PIPE DETAIL OF MEDIAN DI TYPE A EXTRA DEPTH OVER 12' TO 25' DETAIL OF WOVEN WIRE FENCE WITH DOUBLE GATE
2D-1 THRU 2D-9	DRAINAGE DETAIL SHEETS
2H-1	GEOENVIRONMENTAL DETAILS
2N-1 THRU 2N-8	NOISE WALL ENVELOPES
3B-1 THRU 3B-5	SUMMARY OF ROADWAY QUANTITIES
3D-1 THRU 3D-22	SUMMARY OF DRAINAGE QUANTITIES
3G-1	SUMMARY OF GEOTECHNICAL QUANTITIES
3P-1 THRU 3P-3	PARCEL INDEX SHEET
4 THRU 86	PLAN AND PROFILE SHEETS
RW-01 THRU RW-32	SURVEY CONTROL, EXISTING CENTERLINES, RIGHT OF WAY SHEETS, EASEMENT AND PROPERTY TIE
TMP-1 THRU TMP-69	TRAFFIC MANAGEMENT PLANS
PMP-1 THRU PMP-36	PAVEMENT MARKING PLANS
EC-1 THRU EC-61	EROSION CONTROL PLANS
SIGN-1 THRU SIGN-5BB	SIGNING PLANS
SIG-1.0 THRU SIG-22.1	SIGNAL PLANS
SIG-M1 THRU SIG-M8	SIGNAL METAL POLE STANDARD DRAWINGS
SCP-1 THRU SCP-3	SIGNAL COMMUNICATION PLANS
UC-1 THRU UC-48	UTILITY CONSTRUCTION PLANS
UO-1 THRU UO-33	UTILITIES BY OTHER PLANS
X-0 THRU X-0F	CROSS-SECTION SUMMARY SHEET AND INDEX
X-1 THRU X-482	CROSS-SECTIONS
S1-1 THRU S1-28	STRUCTURE PLANS BRIDGE NO. 660
S2-1 THRU S2-28	STRUCTURE PLANS BRIDGE NO. 661
S3-1 THRU S3-34	STRUCTURE PLANS BRIDGE NO. 662
S4-1 THRU S4-45	STRUCTURE PLANS BRIDGE NO. 663
C1-1 THRU C1-5	CULVERT PLANS STA. 797+60.00 -L3-
C2-1 THRU C2-5	CULVERT PLANS STA. 832+02.00 -L3-
C3-1 THRU C3-5	CULVERT PLANS STA. 874+45.00 -L3-
C4-1 THRU C4-6	CULVERT PLANS STA. 735+39.00 -L3-
W-1 THRU W-11	RETAINING WALL PLANS
NW-1 THRU NW-8	NOISE WALL PLANS

2018 ROADWAY ENGLISH STANDARD DRAWINGS

The following Roadway Standards as appear in "Roadway Standard Drawings" Highway Design Branch - N. C. Department of Transportation - Raleigh, N. C., Dated January, 2018 are applicable to this project and by reference hereby are considered a part of these plans:

STD.NO.	TITLE
DIVISION 2 - EARTHWORK	
200.02	Method of Clearing - Method II
225.01	Guide for Grading Subgrade - Interstate and Freeway
225.02	Guide for Grading Subgrade - Secondary and Local
225.03	Deceleration and Acceleration Lanes
225.04	Method of Obtaining Superelevation - Two Lane Pavement
225.05	Method of Obtaining Superelevation - Divided Highways
225.06	Method of Grading Sight Distance at Intersections
240.01	Guide for Berm Ditch Construction
DIVISION 3 - PIPE CULVERTS	
300.01	Method of Pipe Installation
310.10	Driveway Pipe Construction
DIVISION 4 - MAJOR STRUCTURES	
422.01	Bridge Approach Fills - Type I Standard Approach Fill
422.03	Reinforced Bridge Approach Fills - Type A Alternate Approach Fill for Integral Abutment
DIVISION 5 - SUBGRADE, BASES AND SHOULDERS	
560.01	Method of Shoulder Construction - High Side of Superelevated Curve - Method I
560.02	Method of Shoulder Construction - High Side of Superelevated Curve - Method II
DIVISION 6 - ASPHALT BASES AND PAVEMENTS	
610.03	Guide for Paving Shoulders Under Bridges - Method III
654.01	Pavement Repairs
DIVISION 8 - INCIDENTALS	
806.01	Concrete Right-of-Way Marker
806.02	Granite Right-of-Way Marker
815.02	Subsurface Drain
815.03	Pipe Underdrain and Blind Drain
816.01	Concrete Pads - for Shoulder Drain Installation
816.02	Aggregate Shoulder Drain
816.03	Geocomposite Shoulder Drain
816.04	Markers for Drainage Structure and Concrete Pad
838.01	Concrete Endwall for Single and Double Pipe Culverts - 15' thru 48" Pipe 90 Skew
838.11	Brick Endwall for Single and Double Pipe Culverts - 15' thru 48" Pipe 90 Skew
838.21	Reinforced Concrete Endwall - for Single 54" Pipe 90 Skew
838.39	Reinforced Concrete Endwall - for Single 72" Pipe 90 Skew
838.45	Notes for Reinforced Concrete Endwall - Std. Dwg 838.21 thru 838.40
838.51	Reinforced Brick Endwall - for Single 54" Pipe 90 Skew
838.69	Reinforced Brick Endwall - for Single 72" Pipe 90 Skew
838.75	Notes for Reinforced Brick Endwall - Std. Dwg 838.51 thru 838.70
838.80	Precast Endwalls - 12" thru 72" Pipe 90 Skew
840.00	Concrete Base Pad for Drainage Structures
840.01	Brick Catch Basin - 12" thru 54" Pipe
840.02	Concrete Catch Basin - 12" thru 54" Pipe
840.03	Frame, Grates and Hood - for Use on Standard Catch Basin
840.04	Concrete Open Throat Catch Basin - 12" thru 48" Pipe
840.05	Brick Open Throat Catch Basin - 12" thru 48" Pipe
840.14	Concrete Drop Inlet - 12" thru 30" Pipe
840.15	Brick Drop Inlet - 12" thru 30" Pipe
840.16	Drop Inlet Frame and Grates - for use with Std. Dwg 840.14 and 840.15
840.17	Concrete Grated Drop Inlet Type 'A' - 12" thru 72" Pipe
840.18	Concrete Grated Drop Inlet Type 'B' - 12" thru 36" Pipe
840.19	Concrete Grated Drop Inlet Type 'D' - 12" thru 36" Pipe
840.20	Frames and Wide Slot Flat Grates
840.22	Frames and Narrow Slot Sag Grates
840.24	Anchorage for Frames - Brick or Concrete or Precast
840.25	Brick Grated Drop Inlet Type 'A' - 12" thru 72" Pipe
840.26	Brick Grated Drop Inlet Type 'B' - 12" thru 36" Pipe
840.27	Brick Grated Drop Inlet Type 'D' - 12" thru 36" Pipe
840.28	Frames and Narrow Slot Flat Grates
840.29	Concrete Junction Box - 12" thru 66" Pipe
840.31	Brick Junction Box - 12" thru 66" Pipe
840.32	Traffic Bearing Grated Drop Inlet - for Cast Iron Double Frame and Grates
840.35	Traffic Bearing Grated Drop Inlet - for Steel (840.37) Double Frame and Grates
840.36	Steel Grate and Frame
840.37	Spring Box - Concrete or Brick
840.41	Precast Drainage Structure
840.45	Traffic Bearing Precast Drainage Structure
840.46	Manhole Frame and Cover
840.54	Drainage Structure Steps
840.66	Concrete and Brick Pipe Plug
840.71	Pipe Collar
840.72	Concrete Curb, Gutter and Curb & Gutter
846.01	Drop Inlet Installation in Shoulder Berm Gutter
846.04	Concrete Sidewalk
848.01	Driveway Turnout - Radius Type
848.02	Street Turnout
848.04	Curb Ramp - Proposed Curb & Gutter
848.05	Curb Ramp - Existing Curb & Gutter
850.01	Concrete Paved Ditches
850.10	Guide for Berm Drainage Outlet - 15' and 18" Pipe
850.11	Guide for Berm Drainage Outlet - 24" and 30" Pipe
852.01	Concrete Islands
852.02	Concrete Mountable Median - for Use with Rigid or Flexible Pavement
852.04	Method for Placement of Drop Inlets in Grassed Median - Using 1'-6" Curb and Gutter
852.06	Method for Placement of Drop Inlets in Concrete Islands
857.01	Precast Reinforced Concrete Barrier - 41' Single Faced
862.01	Guardrail Placement
862.02	Guardrail Installation
862.03	Structure Anchor Units
862.04	Anchoring End of Guardrail - B-77 and B-83 Anchor Units
865.01	Cable Guiderail
866.02	Woven Wire Fence - with Wood Post
876.01	Rip Rap in Channels
876.02	Guide for Rip Rap at Pipe Outlets
876.04	Drainage Ditches with Class 'B' Rip Rap

EFF. 01-16-2018  
REV.

GENERAL NOTES:

2018 SPECIFICATIONS  
EFFECTIVE: 01-16-2018  
REVISED:

GRADING AND SURFACING OR RESURFACING AND WIDENING:

THE GRADE LINES SHOWN DENOTE THE FINISHED ELEVATION OF THE PROPOSED SURFACING AT GRADE POINTS SHOWN ON THE TYPICAL SECTIONS. WHERE NO GRADE LINES ARE SHOWN, THE PROFILES SHOWN DENOTE THE TOP ELEVATION OF THE EXISTING PAVEMENT ALONG THE CENTER LINE OF SURVEY ON WHICH THE PROPOSED RESURFACING WILL BE PLACED. GRADE LINES MAY BE ADJUSTED BY THE ENGINEER IN ORDER TO SECURE A PROPER TIE-IN.

CLEARING:

CLEARING ON THIS PROJECT SHALL BE PERFORMED TO THE LIMITS ESTABLISHED BY METHOD II.

SUPERELEVATION:

ALL CURVES ON THIS PROJECT SHALL BE SUPERELEVATED IN ACCORDANCE WITH STD. NO. 225.04 AND 225.05 SUPERELEVATION IS TO BE REVOLVED ABOUT THE GRADE POINTS SHOWN ON THE TYPICAL SECTIONS.

SHOULDER CONSTRUCTION:

ASPHALT, EARTH, AND CONCRETE SHOULDER CONSTRUCTION ON THE HIGH SIDE OF SUPERELEVATED CURVES SHALL BE IN ACCORDANCE WITH STD. NO. 560.01 AND 560.02.

SIDE ROADS:

THE CONTRACTOR WILL BE REQUIRED TO DO ALL NECESSARY WORK TO PROVIDE SUITABLE CONNECTIONS WITH ALL ROADS, STREETS, AND DRIVES ENTERING THIS PROJECT. THIS WORK WILL BE PAID FOR AT THE CONTRACT UNIT PRICE FOR THE PARTICULAR ITEMS INVOLVED.

BERM DITCHES:

BERM DITCHES SHALL BE CONSTRUCTED IN ACCORDANCE WITH STD. NO. 240.01 AT LOCATIONS SHOWN ON THE PLANS OR AS DIRECTED BY THE ENGINEER.

SUBSURFACE DRAINS:

SUBSURFACE DRAINS SHALL BE CONSTRUCTED IN ACCORDANCE WITH STD. NO. 815.02 AT LOCATIONS DIRECTED BY THE ENGINEER.

UNDERDRAINS:

UNDERDRAINS SHALL BE CONSTRUCTED IN ACCORDANCE WITH STD. NO. 815.03 AT LOCATIONS DIRECTED BY THE ENGINEER.

SHOULDER DRAINS:

SHOULDER DRAINS SHALL BE CONSTRUCTED IN ACCORDANCE WITH STD. NO. 816.03 AND DETAILS IN PLANS AT LOCATIONS DIRECTED BY THE ENGINEER.

DRIVEWAYS:

DRIVEWAYS SHALL BE CONSTRUCTED IN ACCORDANCE WITH STD. 848.02 USING 3 FOOT RADII OR RADII AS SHOWN ON THE PLANS. LOCATIONS OF DRIVES WILL BE AS SHOWN ON THE PLANS OR AS DIRECTED BY THE ENGINEER.

STREET TURNOUT:

STREET RETURNS SHALL BE CONSTRUCTED IN ACCORDANCE WITH STD. NO. 848.04 USING THE RADII NOTED ON PLANS.

GUARDRAIL:

THE GUARDRAIL LOCATIONS SHOWN ON THE PLANS MAY BE ADJUSTED DURING CONSTRUCTION AS DIRECTED BY THE ENGINEER. THE CONTRACTOR SHOULD CONSULT WITH THE ENGINEER PRIOR TO ORDERING GUARDRAIL MATERIAL.

TEMPORARY SHORING:

SHORING REQUIRED FOR THE MAINTENANCE OF TRAFFIC WILL BE PAID FOR AS "EXTRA WORK" IN ACCORDANCE WITH SECTION 104-7.

END BENTS:

THE ENGINEER SHALL CHECK THE STRUCTURE END BENT PLANS, DETAILS, AND CROSS-SECTION PRIOR TO SETTING OF THE SLOPE STAKES FOR THE EMBANKMENT OR EXCAVATION APPROACHING A BRIDGE.

UTILITIES:

UTILITY OWNERS ON THIS PROJECT ARE: AT&T DISTRIBUTION, DUKE ENERGY DISTRIBUTION, DUKE ENERGY TRANSMISSION, BROAD RIVER WATER AUTHORITY (WATER), PANGAEA INTERNET, PANGAEA INTERNET OSP EMAIL, NORTHLAND COMMUNICATIONS, DOMINION ENERGY (GAS), TOWN OF RUTHERFORDTON (SEWER)

ANY RELOCATION OF EXISTING UTILITIES WILL BE ACCOMPLISHED BY OTHERS, EXCEPT AS SHOWN ON THE PLANS.

RIGHT-OF-WAY MARKERS:

ALL RIGHT-OF-WAY MARKERS ON THIS PROJECT SHALL BE PLACED BY CONTRACT.

CURB RAMPS:

CURB RAMPS ARE SHOWN ON THE PLANS AT APPROXIMATE LOCATIONS. CONSTRUCT ALL CURB RAMPS ACCORDANCE WITH STD 848.05 and/or 848.06

ROCK:

ROCK IS ANTICIPATED BETWEEN:  
 -L- STA. 842+25 TO 845+25, -L- STA. 977+75 TO 978+25 RT, -Y2- STA. 25+25 TO 28+75,  
 -LPC- 17+25 TO 17+99, -RPC- 22+65 TO 25+90, -RPB- 15+25 TO 16+25,  
 -RPB- 18+25 TO 19+60, -RPB- 20+30 TO 24+75, -L3- 761+00 TO 763+00,  
 -L3- 769+00 TO 771+00, -L3- 774+25 TO 774+75, -L3- 776+50 TO 778+00,  
 -L3- 842+00 TO 845+50, -L3- 974+50 TO 974+50, -Y2- 28+51 TO 30+75 LT,  
 -RPB- 13+25 TO 16+50, -RPB- 20+50 TO 20+75, -RPB- 23+00 TO 25+40,  
 -RPC- 14+75 TO 15+75, -RPC- 18+30 TO 26+50, -LPC- 11+25 TO 11+90,  
 -LPC- 14+00 TO 19+20

BLASTING MAY BE REQUIRED FOR EXCAVATION ON THE PROJECT. SEE SECTION 220 OF THE STANDARD SPECIFICATIONS AND IF APPLICABLE, ROCK BLASTING PROVISION.

# STATE OF NORTH CAROLINA, DIVISION OF HIGHWAYS

## CONVENTIONAL PLAN SHEET SYMBOLS

12/2/2016

### BOUNDARIES AND PROPERTY:

State Line	-----
County Line	-----
Township Line	-----
City Line	-----
Reservation Line	-----
Property Line	-----
Existing Iron Pin	○ EIP
Computed Property Corner	✕
Property Monument	□ ECM
Parcel/Sequence Number	⑩③
Existing Fence Line	-x-x-x-
Proposed Woven Wire Fence	○
Proposed Chain Link Fence	□
Proposed Barbed Wire Fence	◇
Existing Wetland Boundary	--- WLB ---
Proposed Wetland Boundary	--- WLB ---
Existing Endangered Animal Boundary	--- EAB ---
Existing Endangered Plant Boundary	--- EPB ---
Existing Historic Property Boundary	--- HPB ---
Known Contamination Area: Soil	☠ S ☠
Potential Contamination Area: Soil	☠ S ☠
Known Contamination Area: Water	☠ W ☠
Potential Contamination Area: Water	☠ W ☠
Contaminated Site: Known or Potential	☠ ? ☠

### BUILDINGS AND OTHER CULTURE:

Gas Pump Vent or U/G Tank Cap	○
Sign	○ S
Well	○ W
Small Mine	✕
Foundation	□
Area Outline	□
Cemetery	□ †
Building	□
School	□
Church	□
Dam	□

### HYDROLOGY:

Stream or Body of Water	~~~~~
Hydro, Pool or Reservoir	□
Jurisdictional Stream	--- JS ---
Buffer Zone 1	--- BZ 1 ---
Buffer Zone 2	--- BZ 2 ---
Flow Arrow	←
Disappearing Stream	→
Spring	○
Wetland	--- WLB ---
Proposed Lateral, Tail, Head Ditch	--- FLOW ---
False Sump	▽

### RAILROADS:

Standard Gauge	-----
RR Signal Milepost	○ CSX TRANSPORTATION MILEPOST 35
Switch	□ SWITCH
RR Abandoned	-----
RR Dismantled	-----

*Note: Not to Scale*      \*S.U.E. = *Subsurface Utility Engineering*

### RIGHT OF WAY & PROJECT CONTROL:

Secondary Horiz and Vert Control Point	◆
Primary Horiz Control Point	○
Primary Horiz and Vert Control Point	●
Exist Permanent Easment Pin and Cap	◇
New Permanent Easment Pin and Cap	◆
Vertical Benchmark	⊠
Existing Right of Way Marker	△
Existing Right of Way Line	-----
New Right of Way Line	--- R/W ---
New Right of Way Line with Pin and Cap	--- R/W --- ◆
New Right of Way Line with Concrete or Granite R/W Marker	--- R/W --- ●
New Control of Access Line with Concrete C/A Marker	--- C/A --- ●
Existing Control of Access	--- C/A --- ○
New Control of Access	--- C/A --- ●
Existing Easement Line	--- E ---
New Temporary Construction Easement	--- E ---
New Temporary Drainage Easement	--- TDE ---
New Permanent Drainage Easement	--- PDE ---
New Permanent Drainage /Utility Easement	--- DUE ---
New Permanent Utility Easement	--- PUE ---
New Temporary Utility Easement	--- TUE ---
New Aerial Utility Easement	--- AUE ---

### ROADS AND RELATED FEATURES:

Existing Edge of Pavement	-----
Existing Curb	-----
Proposed Slope Stakes Cut	--- C ---
Proposed Slope Stakes Fill	--- F ---
Proposed Curb Ramp	--- CR ---
Existing Metal Guardrail	--- T ---
Proposed Guardrail	--- T ---
Existing Cable Guiderail	--- T ---
Proposed Cable Guiderail	--- T ---
Equality Symbol	⊕
Pavement Removal	⊠

### VEGETATION:

Single Tree	○
Single Shrub	●

Hedge	~~~~~
Woods Line	~~~~~
Orchard	○ ○ ○ ○
Vineyard	□ Vineyard

### EXISTING STRUCTURES:

MAJOR:	
Bridge, Tunnel or Box Culvert	--- CONC ---
Bridge Wing Wall, Head Wall and End Wall	--- CONC WW ---
MINOR:	
Head and End Wall	--- CONC HW ---
Pipe Culvert	--- ---
Footbridge	--- ---
Drainage Box: Catch Basin, DI or JB	□ CB
Paved Ditch Gutter	-----
Storm Sewer Manhole	○ S
Storm Sewer	--- S ---

### UTILITIES:

POWER:	
Existing Power Pole	●
Proposed Power Pole	○
Existing Joint Use Pole	●
Proposed Joint Use Pole	○
Power Manhole	⊕
Power Line Tower	⊠
Power Transformer	⊠
U/G Power Cable Hand Hole	○
H-Frame Pole	●
U/G Power Line LOS B (S.U.E.*)	--- P ---
U/G Power Line LOS C (S.U.E.*)	--- P ---
U/G Power Line LOS D (S.U.E.*)	--- P ---

### TELEPHONE:

Existing Telephone Pole	●
Proposed Telephone Pole	○
Telephone Manhole	⊕
Telephone Pedestal	⊠
Telephone Cell Tower	⊠
U/G Telephone Cable Hand Hole	○
U/G Telephone Cable LOS B (S.U.E.*)	--- T ---
U/G Telephone Cable LOS C (S.U.E.*)	--- T ---
U/G Telephone Cable LOS D (S.U.E.*)	--- T ---
U/G Telephone Conduit LOS B (S.U.E.*)	--- TC ---
U/G Telephone Conduit LOS C (S.U.E.*)	--- TC ---
U/G Telephone Conduit LOS D (S.U.E.*)	--- TC ---
U/G Fiber Optics Cable LOS B (S.U.E.*)	--- T FO ---
U/G Fiber Optics Cable LOS C (S.U.E.*)	--- T FO ---
U/G Fiber Optics Cable LOS D (S.U.E.*)	--- T FO ---

### WATER:

Water Manhole	⊕
Water Meter	○
Water Valve	⊗
Water Hydrant	⊕
U/G Water Line LOS B (S.U.E.*)	--- W ---
U/G Water Line LOS C (S.U.E.*)	--- W ---
U/G Water Line LOS D (S.U.E.*)	--- W ---
Above Ground Water Line	--- A/G Water ---

### TV:

TV Pedestal	⊕
TV Tower	⊗
U/G TV Cable Hand Hole	○
U/G TV Cable LOS B (S.U.E.*)	--- TV ---
U/G TV Cable LOS C (S.U.E.*)	--- TV ---
U/G TV Cable LOS D (S.U.E.*)	--- TV ---
U/G Fiber Optic Cable LOS B (S.U.E.*)	--- TV FO ---
U/G Fiber Optic Cable LOS C (S.U.E.*)	--- TV FO ---
U/G Fiber Optic Cable LOS D (S.U.E.*)	--- TV FO ---

### GAS:

Gas Valve	◇
Gas Meter	⊕
U/G Gas Line LOS B (S.U.E.*)	--- G ---
U/G Gas Line LOS C (S.U.E.*)	--- G ---
U/G Gas Line LOS D (S.U.E.*)	--- G ---
Above Ground Gas Line	--- A/G Gas ---

### SANITARY SEWER:

Sanitary Sewer Manhole	⊕
Sanitary Sewer Cleanout	⊕
U/G Sanitary Sewer Line	--- SS ---
Above Ground Sanitary Sewer	--- A/G Sanitary Sewer ---
SS Forced Main Line LOS B (S.U.E.*)	--- FSS ---
SS Forced Main Line LOS C (S.U.E.*)	--- FSS ---
SS Forced Main Line LOS D (S.U.E.*)	--- FSS ---

### MISCELLANEOUS:

Utility Pole	●
Utility Pole with Base	□
Utility Located Object	○
Utility Traffic Signal Box	⊠
Utility Unknown U/G Line LOS B (S.U.E.*)	--- ZUTL ---
U/G Tank; Water, Gas, Oil	□
Underground Storage Tank, Approx. Loc.	⊕
A/G Tank; Water, Gas, Oil	□
Geoenvironmental Boring	⊕
U/G Test Hole LOS A (S.U.E.*)	⊕
Abandoned According to Utility Records	AATUR
End of Information	E.O.I.



6/2/2021

# PAVEMENT SCHEDULE (FINAL)

PROJECT REFERENCE NO. R-2233BB SHEET NO. 2A-1

ITEM	DESCRIPTION	ITEM	DESCRIPTION	ITEM	DESCRIPTION		
A1	7" CONCRETE TRUCK APRON	E4	PROP. APPROX. 5.0" ASPHALT CONCRETE BASE COURSE, TYPE B25.0C, AT AN AVERAGE RATE OF 570 LBS. PER SQ. YARD.	R4	PROPOSED 2'-0" MODIFIED VALLEY GUTTER		
C1	PROP. APPROX. 1.5" ASPHALT CONCRETE SURFACE COURSE, TYPE S9.5B, AT AN AVERAGE RATE OF 165 LBS. PER SQ. YARD.	E5	PROP. VAR. DEPTH ASPHALT CONCRETE BASE COURSE, TYPE B25.0C, AT AN AVERAGE RATE OF 114 LBS. PER SQ. YARD PER 1" DEPTH TO BE PLACED IN LAYERS NOT LESS THAN 3" OR GREATER THAN 5.5" IN DEPTH.	R5	PROPOSED 8" x 12" CONCRETE CURB		
C2	PROP. APPROX. 3" ASPHALT CONCRETE SURFACE COURSE, TYPE S9.5B, AT AN AVERAGE RATE OF 165 LBS. PER SQ. YARD IN EACH OF TWO LAYERS.	J1	PROP. 6" AGGREGATE BASE COURSE	R6	PROPOSED CONCRETE EXPRESSWAY GUTTER		
C3	PROP. VAR. DEPTH ASPHALT CONCRETE SURFACE COURSE, TYPE S9.5B, AT AN AVERAGE RATE OF 110 LBS. PER SQ. YARD PER 1" IN DEPTH TO BE PLACED IN LAYERS NOT TO EXCEED 1.5" IN DEPTH.	J2	PROP. 8" AGGREGATE BASE COURSE	S	4" CONCRETE SIDEWALK		
C4	PROP. APPROX. 3.0" ASPHALT CONCRETE SURFACE COURSE, TYPE S9.5C, AT AN AVERAGE RATE OF 168 LBS. PER SQ. YARD IN EACH OF TWO LAYERS.	K1	PROP. CHEMICAL STABILIZATION (SOIL-CEMENT BASE/LIME-TREATED SOIL). BASE TREATED WITH CEMENT AT A RATE OF 56 LBS. PER SQ. YARD @ 7" DEPTH OR SOIL TREATED WITH LIME AT A RATE OF 24 LBS. PER SQ. YARD @ 8" DEPTH.	T	EARTH		
C5	PROP. VAR. DEPTH ASPHALT CONCRETE SURFACE COURSE, TYPE S9.5C, AT AN AVERAGE RATE OF 112 LBS. PER SQ. YARD PER 1" IN DEPTH TO BE PLACED IN LAYERS NOT TO EXCEED 2" IN DEPTH.	K2	PROP. 8" CLASS IV SUBGRADE STABILIZATION	U	EXISTING PAVEMENT		
D1	PROP. APPROX. 2.5" ASPHALT CONCRETE INTERMEDIATE COURSE, TYPE I19.0C, AT AN AVERAGE RATE OF 285 LBS. PER SQ. YARD.	N1	GEOTEXTILE FOR SOIL STABILIZATION	V1	INCIDENTAL MILLING (SEE MILLING DETAIL V1)		
D2	PROP. APPROX. 4.0" ASPHALT CONCRETE INTERMEDIATE COURSE, TYPE I19.0C, AT AN AVERAGE RATE OF 456 LBS. PER SQ. YARD.	N2	GEOTEXTILE FOR PAVEMENT STABILIZATION	V2	INCIDENTAL MILLING (SEE MILLING DETAIL V2)		
D3	PROP. VAR. DEPTH ASPHALT CONC. INTERMEDIATE COURSE, TYPE I19.0C, AT AN AVERAGE RATE OF 114 LBS. PER SQ. YARD PER 1" DEPTH TO BE PLACED IN LAYERS NOT LESS THAN 2.5" OR GREATER THAN 4" IN DEPTH.	P	PRIME COAT AT THE NORMAL APPLICATION RATE OF 0.35 GAL. PER SQ. YARD	V3	1.5" PAVEMENT MILLING		
E1	PROP. APPROX. 3.0" ASPHALT CONCRETE BASE COURSE, TYPE B25.0C, AT AN AVERAGE RATE OF 342 LBS. PER SQ. YARD.	R1	2'-6" CONCRETE CURB AND GUTTER	V4	0" TO 3" PAVEMENT MILLING		
E2	PROP. APPROX. 4.0" ASPHALT CONCRETE BASE COURSE, TYPE B25.0C, AT AN AVERAGE RATE OF 456 LBS. PER SQ. YARD.	R2	SHOULDER BERM GUTTER (SBG)	Z	MILLED RUMBLE STRIP		
E3	PROP. APPROX. 4.5" ASPHALT CONCRETE BASE COURSE, TYPE B25.0C, AT AN AVERAGE RATE OF 513 LBS. PER SQ. YARD.	R3	5" MONOLITHIC CONCRETE ISLAND (KEYED IN)	W1	W2	W3	VARIABLE DEPTH ASPHALT (SEE WEDGING DETAILS ON THIS SHEET)

ROADWAY DESIGN ENGINEER

PAVEMENT DESIGN ENGINEER

**DOCUMENT NOT CONSIDERED FINAL UNLESS ALL SIGNATURES COMPLETED**

2410 WYCLIFF ROAD  
SUITE 410  
RALEIGH, NC 27607  
PHONE: 919.881.9939  
NC REG. NO. F-00693

NC DEPARTMENT OF TRANSPORTATION  
PAVEMENT MANAGEMENT UNIT  
1593 MAIL SERVICE CENTER  
RALEIGH, NC 27699-1593

- NOTES:
1. ALL PAVEMENT EDGE SLOPES ARE 1:1 UNLESS OTHERWISE NOTED.
  2. USE 4:1 MAX SLOPES ON THE INSIDE OF INTERCHANGE AREAS.
  3. SEE PLANS FOR LOCATION OF ACCELERATION AND DECELERATION LANES.
  4. SEE PLANS FOR LOCATION OF TURN LANE AND INTERSECTION TURNOUTS.
  5. SEE PLANS FOR LOCATION OF ALL PAVEMENT TAPERS.
  6. ALL DRIVEWAY RADII ARE 10' UNLESS SHOWN OTHERWISE ON PLANS.

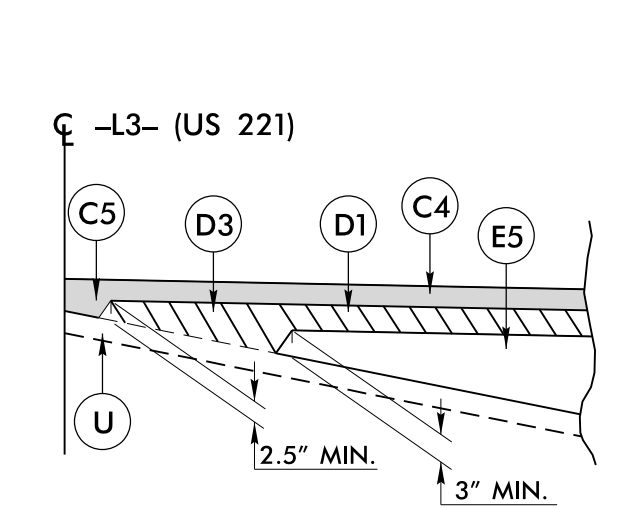

**WEDGING DETAIL - W1**  
USE IN CONJUNCTION WITH TS Nos. 5 & 5A

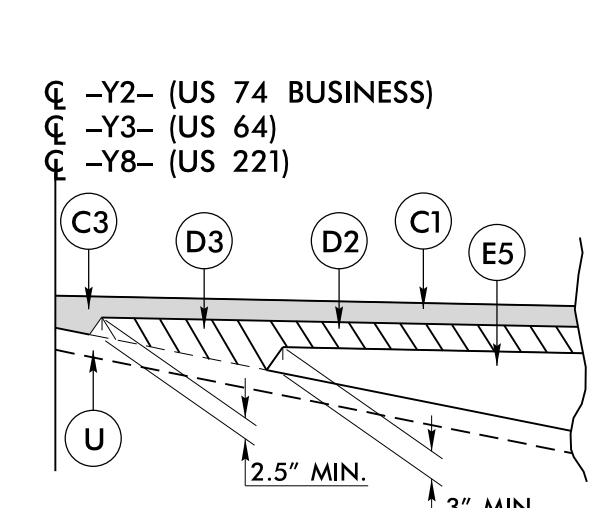

**WEDGING DETAIL - W2**  
USE IN CONJUNCTION WITH TS Nos. 6, 7A, & 19A

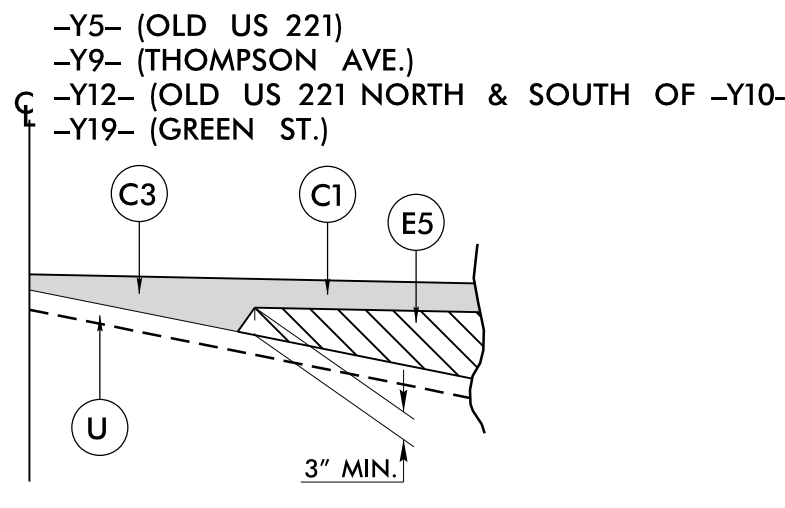

**WEDGING DETAIL - W3**  
USE IN CONJUNCTION WITH TS No. 8A, 15 & 20

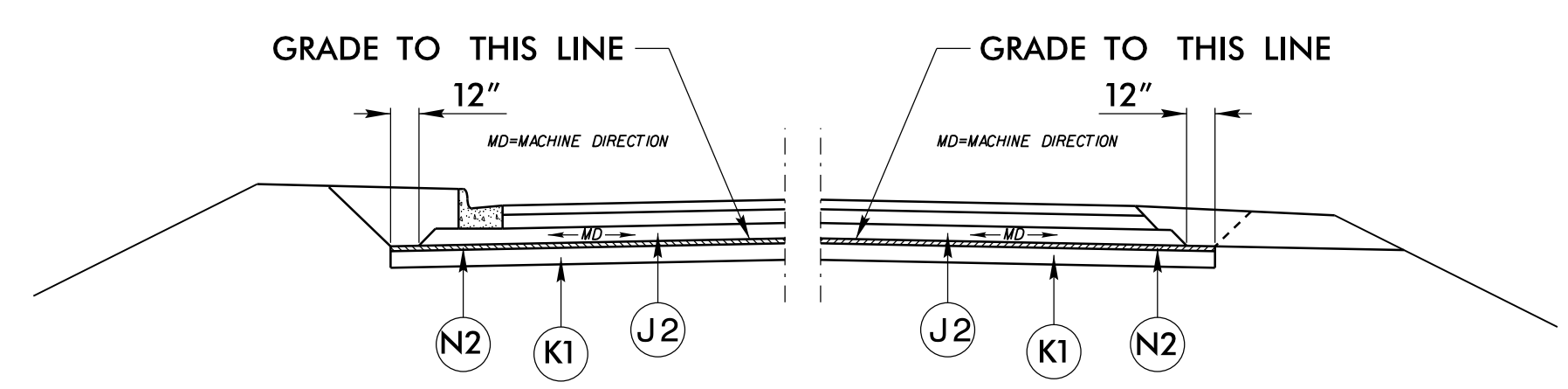

**DETAIL FOR CHEMICAL STABILIZATION-GEOTEXTILE FOR PAVEMENT STABILIZATION WITH ABC**  
USE IN CONJUNCTION WITH TYPICAL SECTIONS No. 1, 5, 13, & 14 WHERE GEOTEXTILE IS REQUIRED. FOR LOCATIONS SEE SHEET 3G-1.

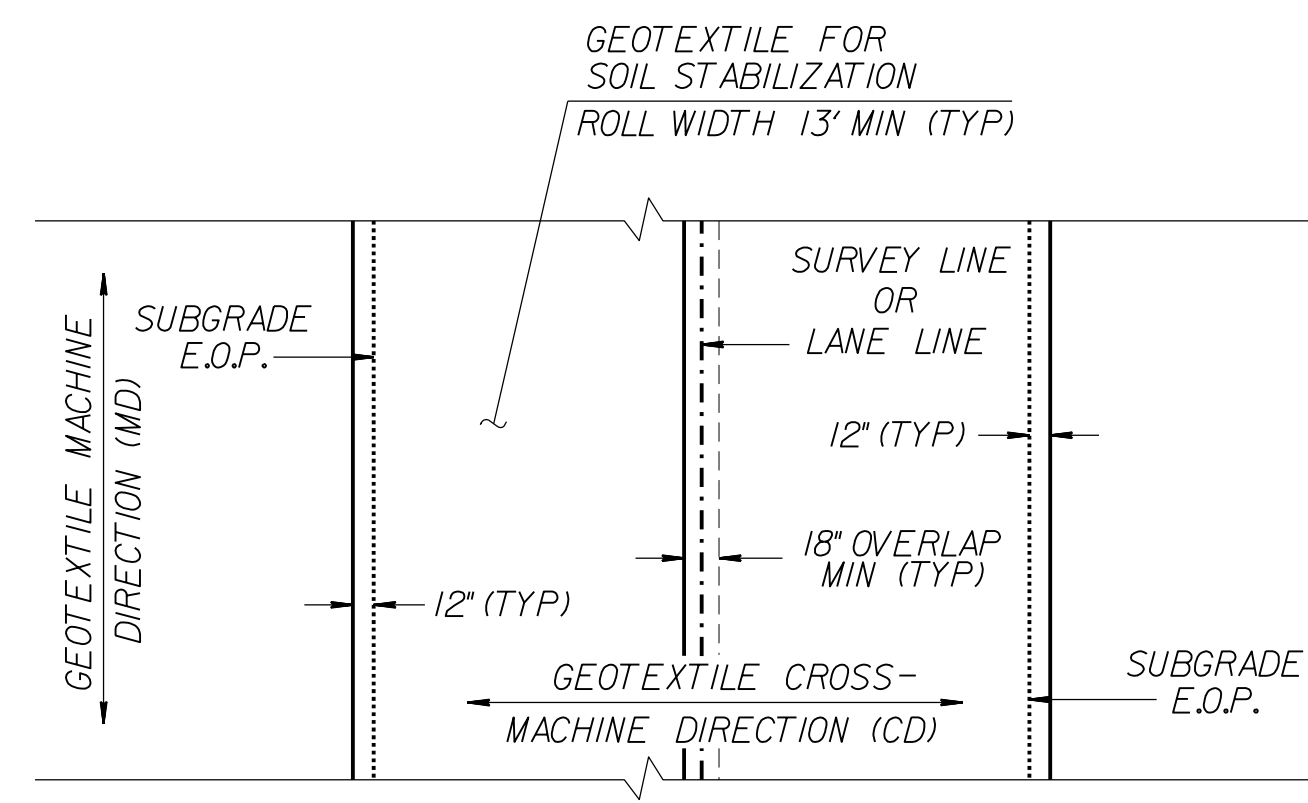

**GEOTEXTILE FOR SOIL STABILIZATION PLACEMENT (PLAN VIEW)**  
**(100% COVERAGE REQUIRED)**

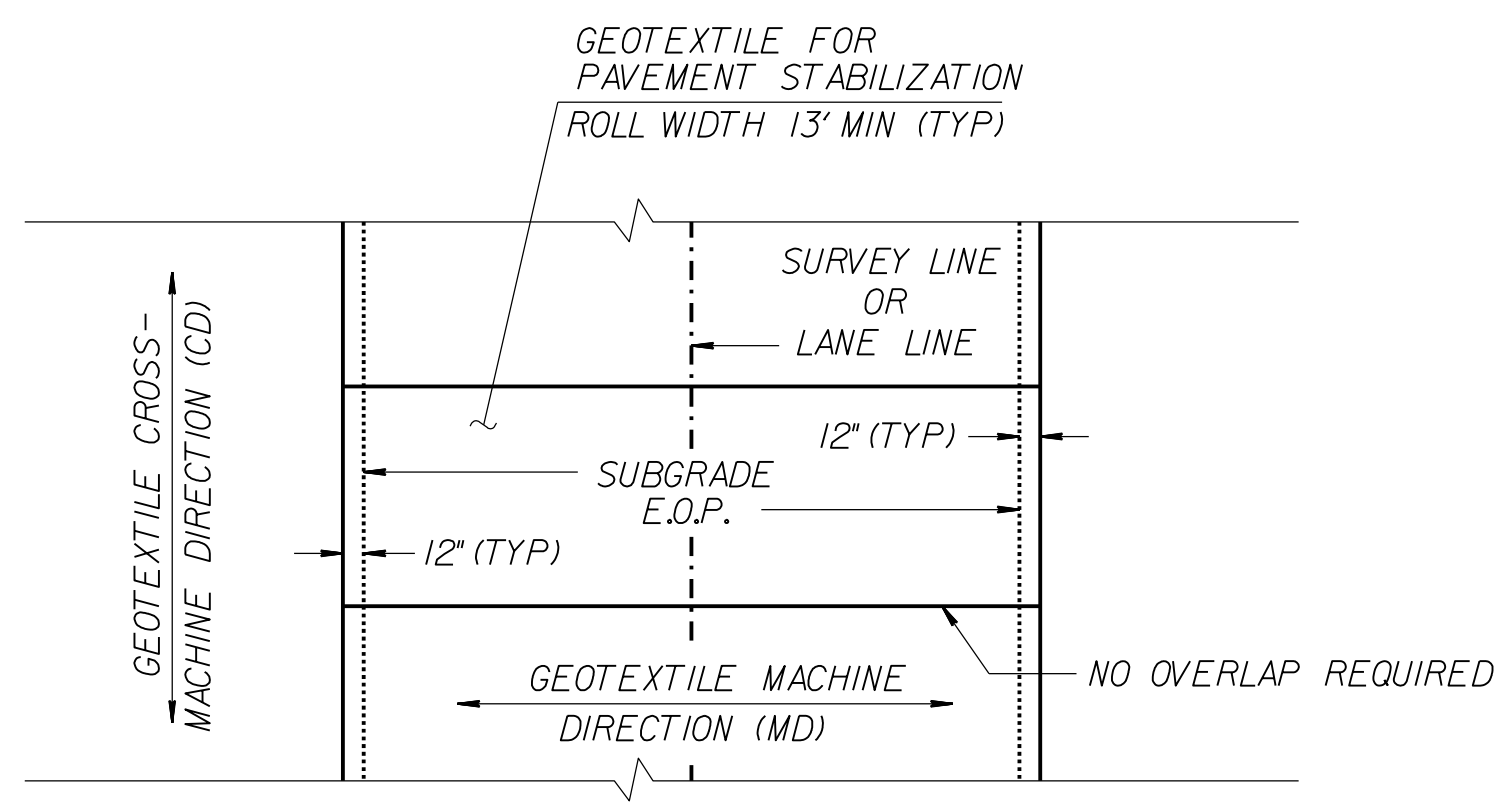

**GEOTEXTILE FOR PAVEMENT STABILIZATION PLACEMENT (PLAN VIEW)**  
**(100% COVERAGE REQUIRED)**

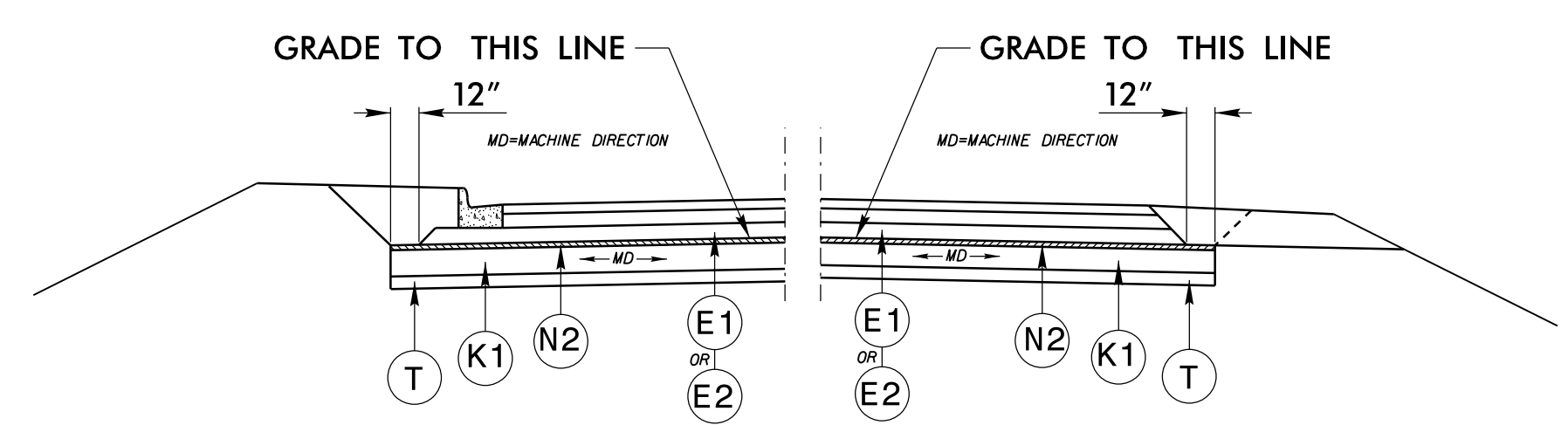

**DETAIL FOR CHEMICAL STABILIZATION-GEOTEXTILE FOR PAVEMENT STABILIZATION WITH ASPHALT BASE**  
USE IN CONJUNCTION WITH TYPICAL SECTIONS No. 7, 7A, 8, 9, 9A, 9B, 10, 12, 15, 16, 17, 18, 19, 19A, 21, 22 & 23 WHERE GEOTEXTILE IS REQUIRED. FOR LOCATIONS SEE SHEET 3G-1.

8/10/2021 3:49:27 PM  
R-2233BB-RD-TYP\_2A-1.DGN



6/2/2021

**PAVEMENT SCHEDULE (FINAL)**

ITEM	DESCRIPTION	ITEM	DESCRIPTION	ITEM	DESCRIPTION	ITEM	DESCRIPTION	ITEM	DESCRIPTION	ITEM	DESCRIPTION	ITEM	DESCRIPTION	ITEM	DESCRIPTION
(A1)	7" CONCRETE	(C4)	3" S9.5C	(D3)	VAR DEPTH I19.0C	(E4)	5" B25.0C	(K1)	CHEMICAL STABILIZATION: 7" SOIL-CEMENT BASE OR 8" LIME-TREATED SOIL	(R1)	2'-6" CONCRETE CURB & GUTTER	(R5)	8"x12" CONCRETE CURB	(U)	EXIST. PAVEMENT
(C1)	1.5" S9.5B	(C5)	VAR DEPTH S9.5C	(E1)	3" B25.0C	(E5)	VAR DEPTH B25.0C	(K2)	8" CLASS IV SUBGRADE STABILIZATION	(R2)	SHOULDER BERM GUTTER	(R6)	CONCRETE EXPRESSWAY GUTTER	(Z)	MILLED RUMBLE STRIP
(C2)	3" S9.5B	(D1)	2.5" I19.0C	(E2)	4" B25.0C	(J1)	6" ABC	(N1)	GEOTEXTILE FOR SOIL STABILIZATION	(R3)	5" CONC. ISLAND	(S)	4" CONC. SIDEWALK	(V1) (V2) (V3) (V4)	PAVEMENT MILLING
(C3)	VAR DEPTH S9.5B	(D2)	4" I19.0C	(E3)	4.5" B25.0C	(J2)	8" ABC	(N2)	GEOTEXTILE FOR PAVEMENT STABILIZATION	(P)	PRIME COAT	(R4)	2' MODIFIED VALLEY GUTTER	(T)	EARTH
														(W1) (W2) (W3)	VARIABLE DEPTH PAVEMENT WEDGING

PROJECT REFERENCE NO. R-2233BB	SHEET NO. 2A-2
ROADWAY DESIGN ENGINEER 	PAVEMENT DESIGN ENGINEER 
DOCUMENT NOT CONSIDERED FINAL UNLESS ALL SIGNATURES COMPLETED	
 2410 WYCLIFF ROAD SUITE 410 RALEIGH, NC 27607 PHONE: 919.881.9539 NC. REG. NO. F-09029	
NC DEPARTMENT OF TRANSPORTATION PAVEMENT MANAGEMENT UNIT 1593 MAIL SERVICE CENTER RALEIGH, NC 27699-1593	

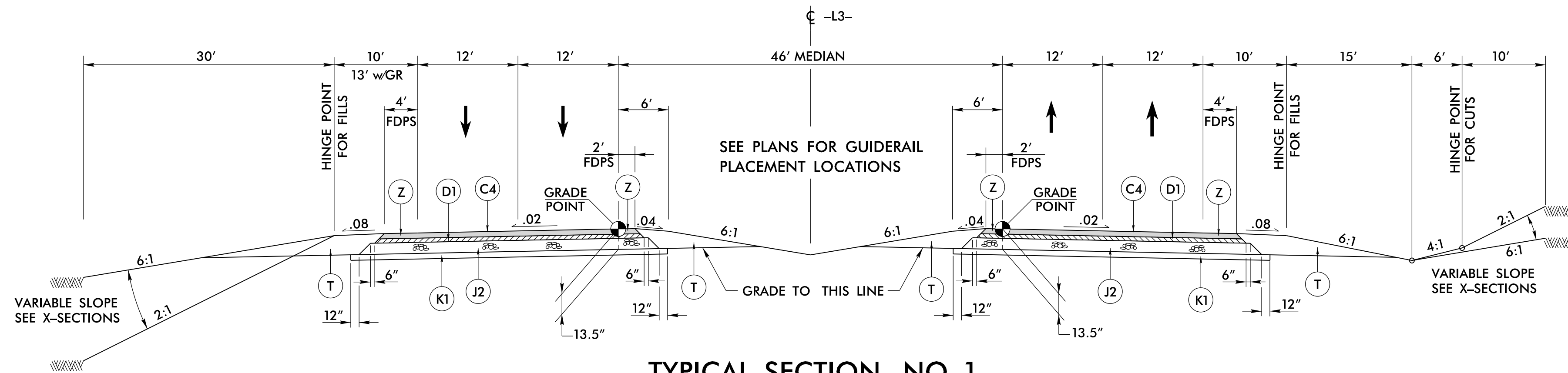

**TYPICAL SECTION NO. 1**  
NOTE: SEE SHEET 2A-9 FOR THE GRADING ONLY  
TYPICAL SECTION FROM -L3- 732+00.00 TO -L3- 743+00

**SOUTHBOUND LANES**  
-L3- 744+75.00 TO -L3- 773+94.15 (BRIDGE)  
-L3- 774+97.75 (BRIDGE) TO -L3- 948+00.00

**NORTHBOUND LANES**  
-L3- 744+75.00 TO -L3- 773+85.37 (BRIDGE)  
-L3- 774+88.77 (BRIDGE) TO -L3- 955+00.00

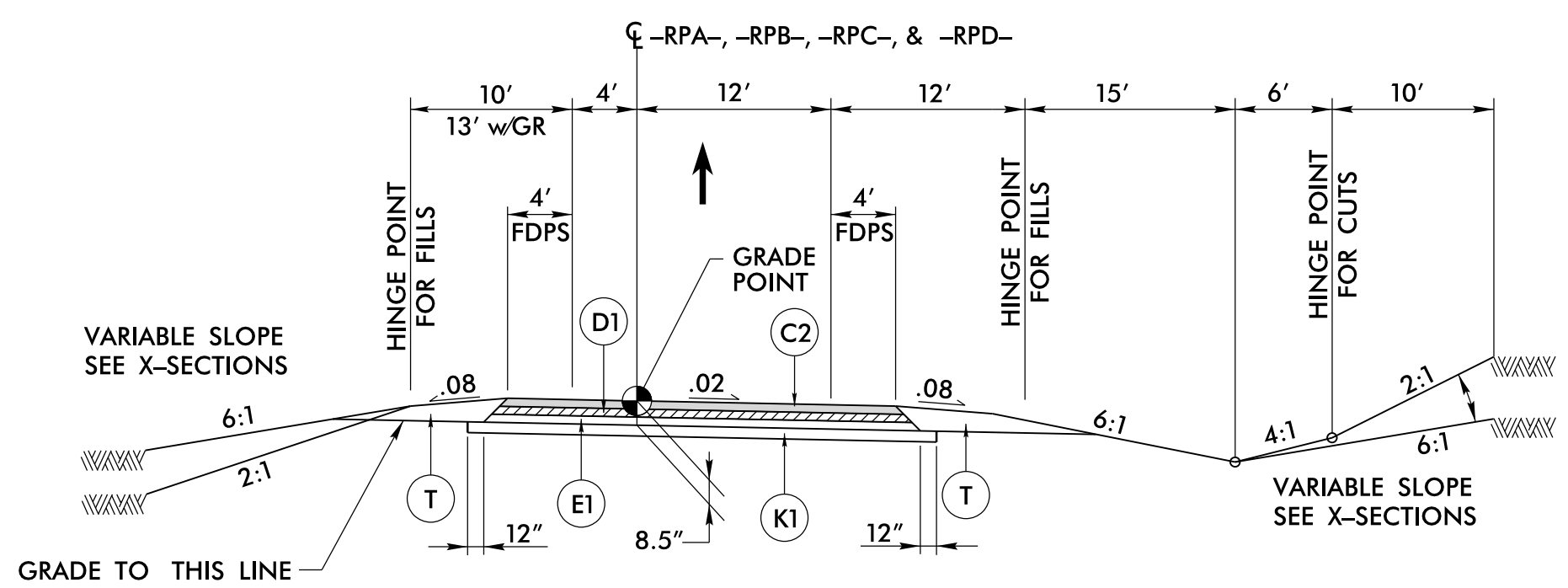

**TYPICAL SECTION NO. 2**  
-RPA- 14+53.78 TO -RPA- 23+94.24    -RPB- 13+70.55 TO -RPB- 25+50.13  
-RPC- 14+56.68 TO -RPC- 23+71.04    -RPD- 13+36.43 TO -RPD- 24+00.00

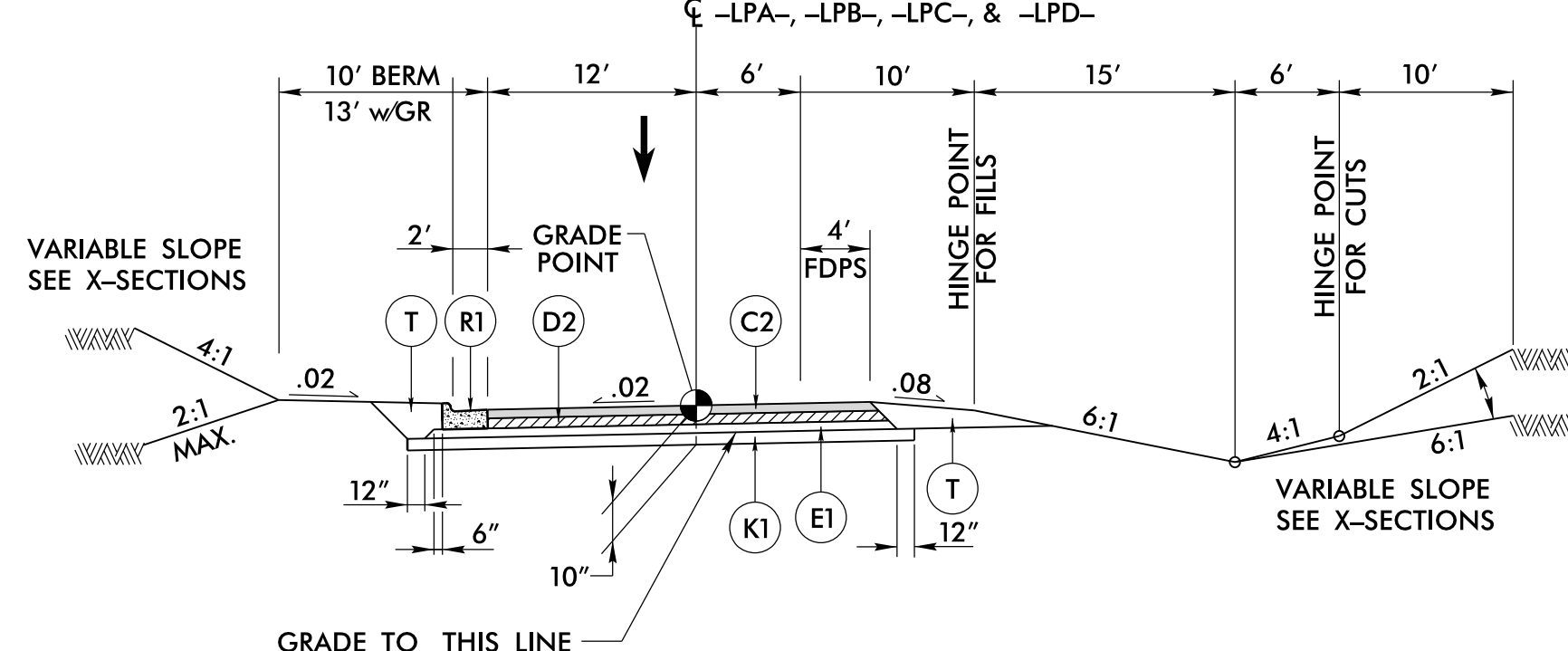

**TYPICAL SECTION NO. 3**  
-LPA- 11+61.84 TO -LPA- 16+31.16    -LPB- 12+89.84 TO -LPB- 17+01.04  
-LPC- 11+83.18 TO -LPC- 16+33.37    -LPD- 15+12.97 TO -LPD- 19+71.53

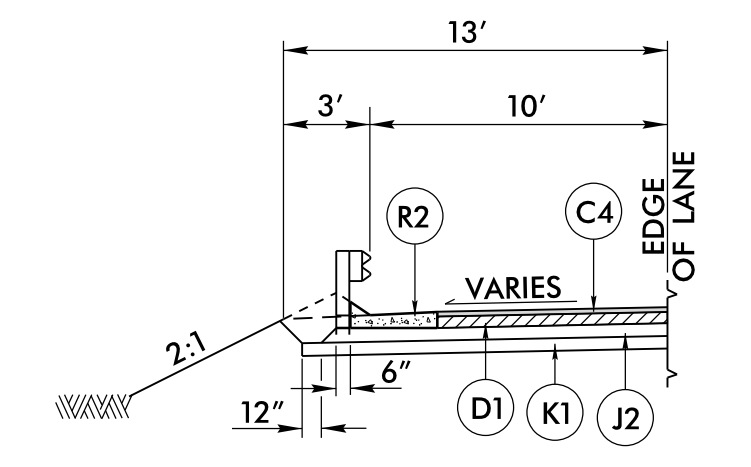

**DETAIL FOR SHOULDER BERM GUTTER**  
USE IN CONJUNCTION WITH -L3- TYPICAL SECTION No.1

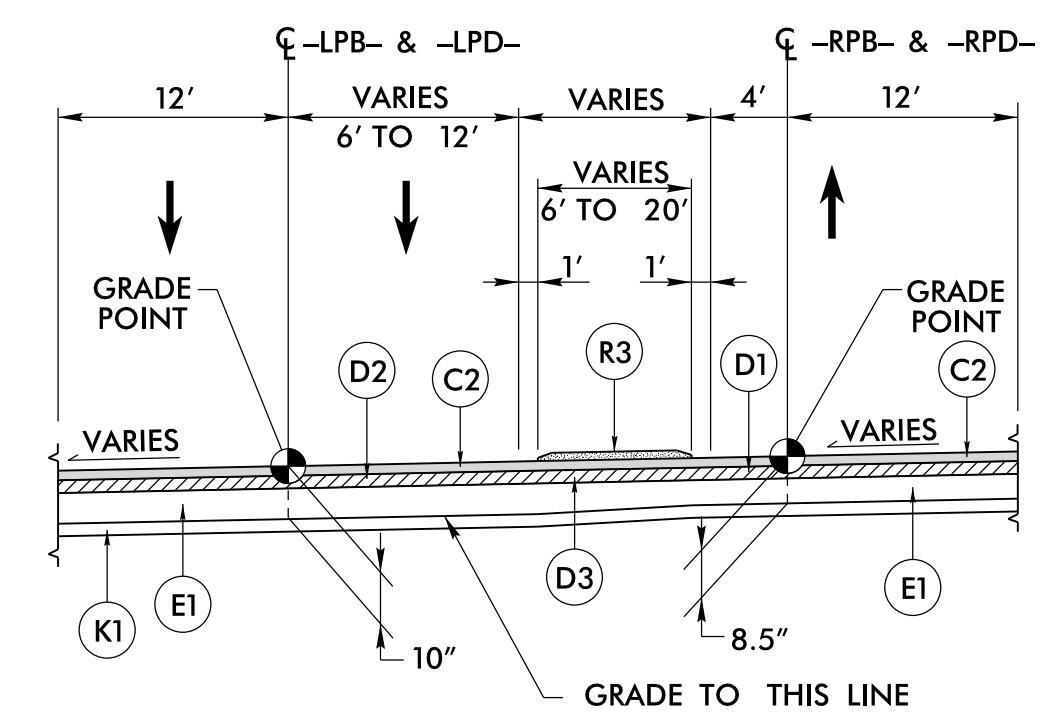

**TYPICAL SECTION NO. 4**  
-LPB- 17+01.04 TO -LPB- 21+72.55    -LPD- 19+71.53 TO -LPD- 26+53.27  
-RPB- 25+50.13 TO -RPB- 30+40.47    -RPD- 24+00.00 TO -RPD- 30+87.27

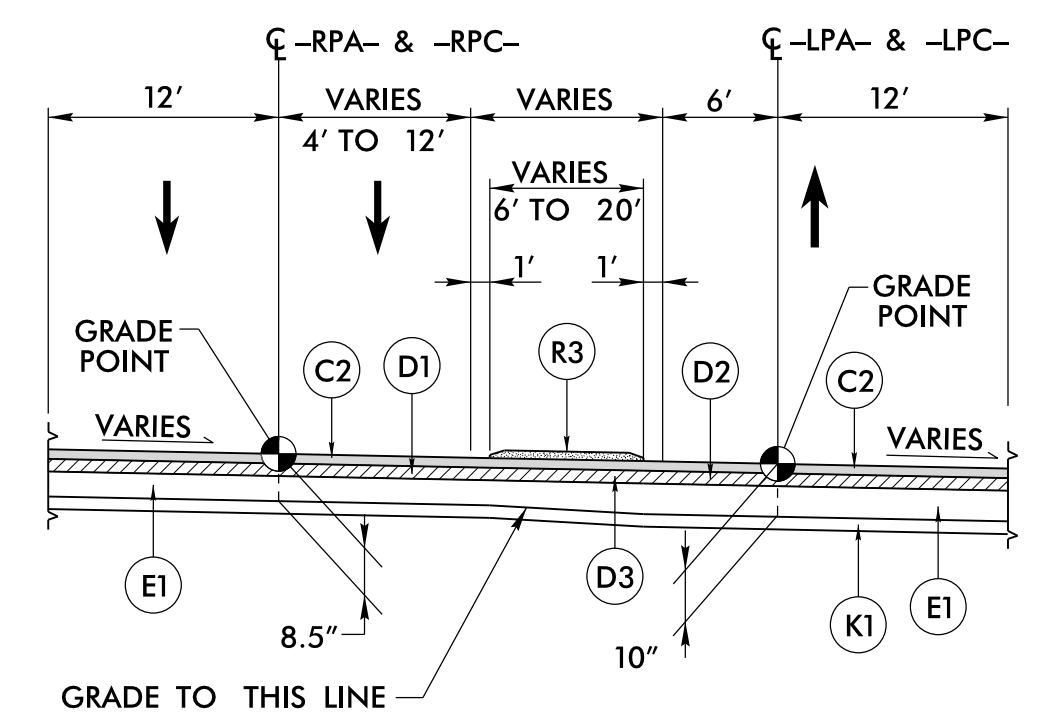

**TYPICAL SECTION NO. 4A**  
-LPC- 16+33.37 TO -LPC- 19+61.65    -LPA- 16+31.16 TO -LPA- 19+53.84  
-RPC- 23+71.04 TO -RPC- 27+03.60    -RPA- 23+94.24 TO -RPA- 27+23.95

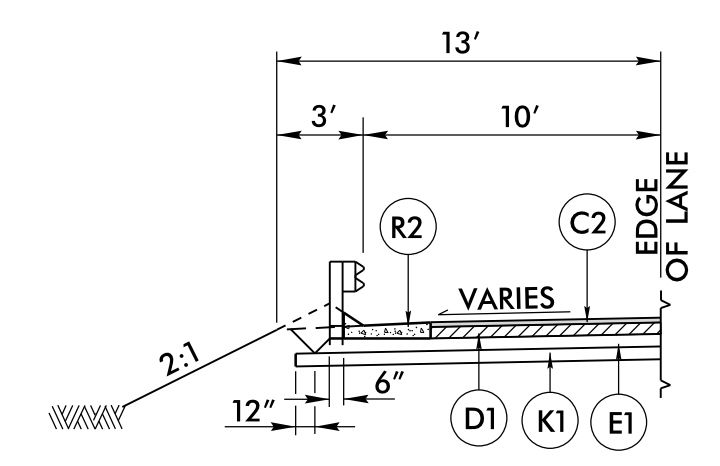



**DETAIL FOR SHOULDER BERM GUTTER**  
USE IN CONJUNCTION WITH -RPD- TYPICAL SECTION No.2

8/10/2021 3:20:40 PM  
R-2233BB.P01\_TYP\_2A-2.DGN

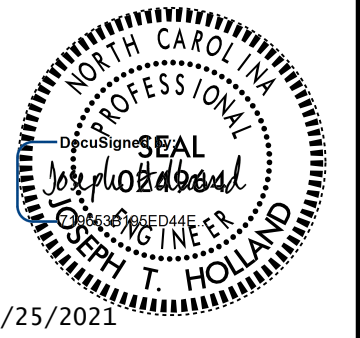

**PAVEMENT SCHEDULE (FINAL)**

ITEM	DESCRIPTION	ITEM	DESCRIPTION	ITEM	DESCRIPTION	ITEM	DESCRIPTION	ITEM	DESCRIPTION	ITEM	DESCRIPTION	ITEM	DESCRIPTION	ITEM	DESCRIPTION				
(A1)	7" CONCRETE	(C4)	3" S9.5C	(D3)	VAR DEPTH I19.0C	(E4)	5" B25.0C	(K1)	CHEMICAL STABILIZATION: 7" SOIL-CEMENT BASE OR 8" LIME-TREATED SOIL	(R1)	2'-6" CONCRETE CURB & GUTTER	(R5)	8"x12" CONCRETE CURB	(U)	EXIST. PAVEMENT				
(C1)	1.5" S9.5B	(C5)	VAR DEPTH S9.5C	(E1)	3" B25.0C	(E5)	VAR DEPTH B25.0C	(K2)	8" CLASS IV SUBGRADE STABILIZATION	(R2)	SHOULDER BERM GUTTER	(R6)	CONCRETE EXPRESSWAY GUTTER	(Z)	MILLED RUMBLE STRIP				
(C2)	3" S9.5B	(D1)	2.5" I19.0C	(E2)	4" B25.0C	(J1)	6" ABC	(N1)	GEOTEXTILE FOR SOIL STABILIZATION	(R3)	5" CONC. ISLAND	(S)	4" CONC. SIDEWALK	(V1)	(V2)	(V3)	(V4)	PAVEMENT MILLING	
(C3)	VAR DEPTH S9.5B	(D2)	4" I19.0C	(E3)	4.5" B25.0C	(J2)	8" ABC	(N2)	GEOTEXTILE FOR PAVEMENT STABILIZATION	(P)	PRIME COAT	(R4)	2' MODIFIED VALLEY GUTTER	(T)	EARTH	(W1)	(W2)	(W3)	VARIABLE DEPTH PAVEMENT WEDGING

PROJECT REFERENCE NO. R-2233BB	SHEET NO. 2A-3
ROADWAY DESIGN ENGINEER 	PAVEMENT DESIGN ENGINEER 
<b>DOCUMENT NOT CONSIDERED FINAL UNLESS ALL SIGNATURES COMPLETED</b>	
	
2410 WYCLIFF ROAD SUITE 410 RALEIGH, NC 27607 PHONE: 919.881.9939 NC CCA No. F-0929 NC DEPARTMENT OF TRANSPORTATION PAVEMENT MANAGEMENT UNIT 1593 MAIL SERVICE CENTER RALEIGH, NC 27699-1393	

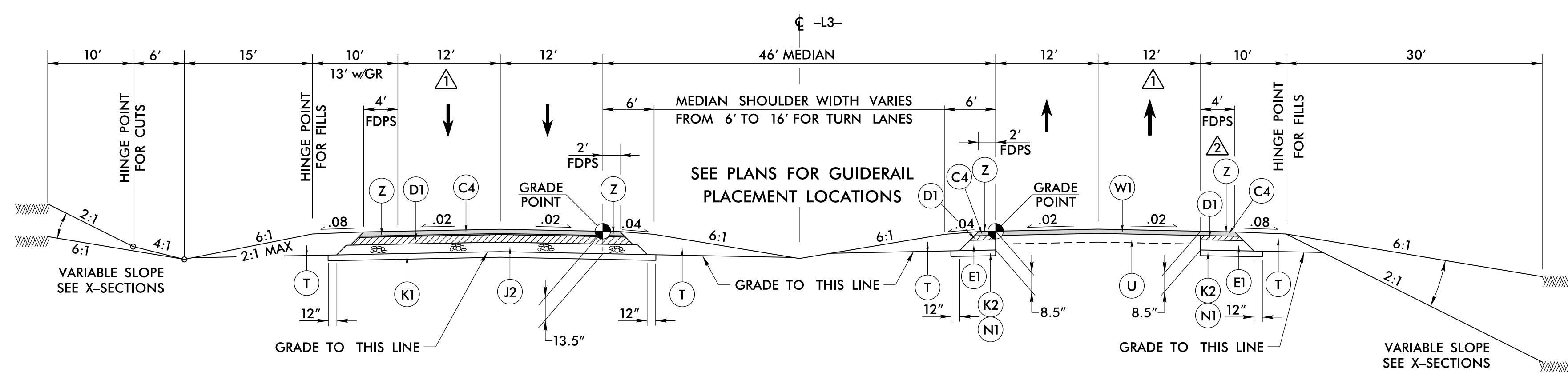

▲ PAVEMENT WIDTH VARIES FROM 12' TO 30' FOR SUPERSTREET BULB-OUTS.      ▲ PAVEMENT WIDENING WIDTH VARIES FROM 4' TO 22' FOR SUPERSTREET BULB-OUTS.

**TYPICAL SECTION NO. 5**

**SOUTHBOUND LANES**

-L3- 948+00.00 TO -L3- 952+00.00  
(PAVEMENT WEDGING FROM 0' TO 24')  
-L3- 952+00.00 TO -L3- 996+27.26  
(FULL DEPTH PAVEMENT)

**NORTHBOUND LANES**

-L3- 955+00.00 TO -L3- 996+27.26

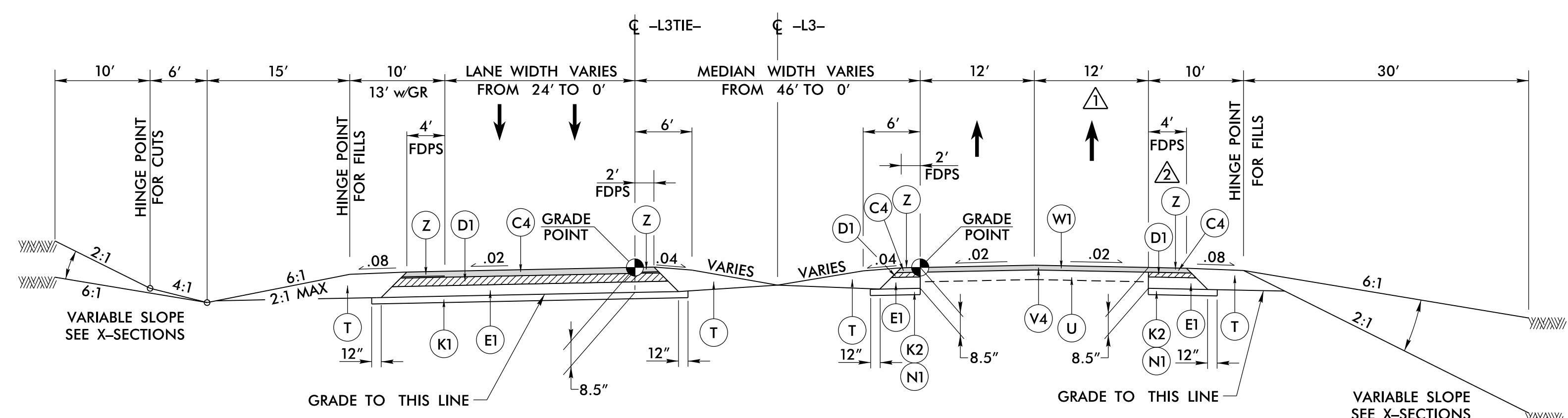

**TYPICAL SECTION NO. 5A**

**SOUTHBOUND LANES**

-L3TIE- 10+00.00 TO -L3TIE- 17+29.95

**NORTHBOUND LANES**

-L3- 996+27.26 TO -L3- 1004+00.00

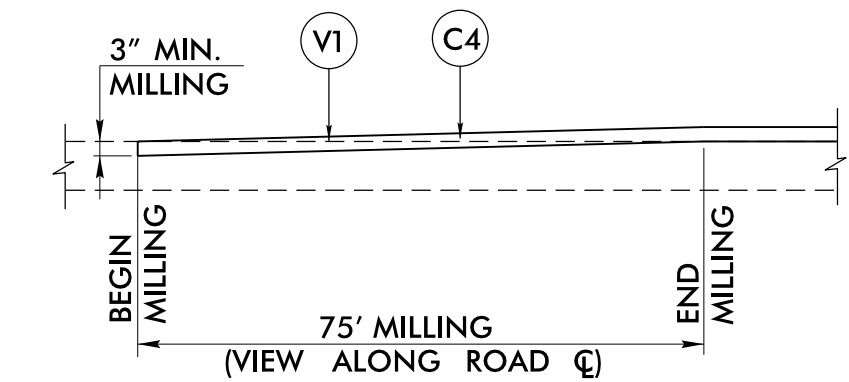

**INCIDENTAL MILLING DETAIL - V1**  
USE IN CONJUNCTION WITH TYPICAL SECTION No. 5A  
-L3- 1003+25.00 TO -L3- 1004+00.00

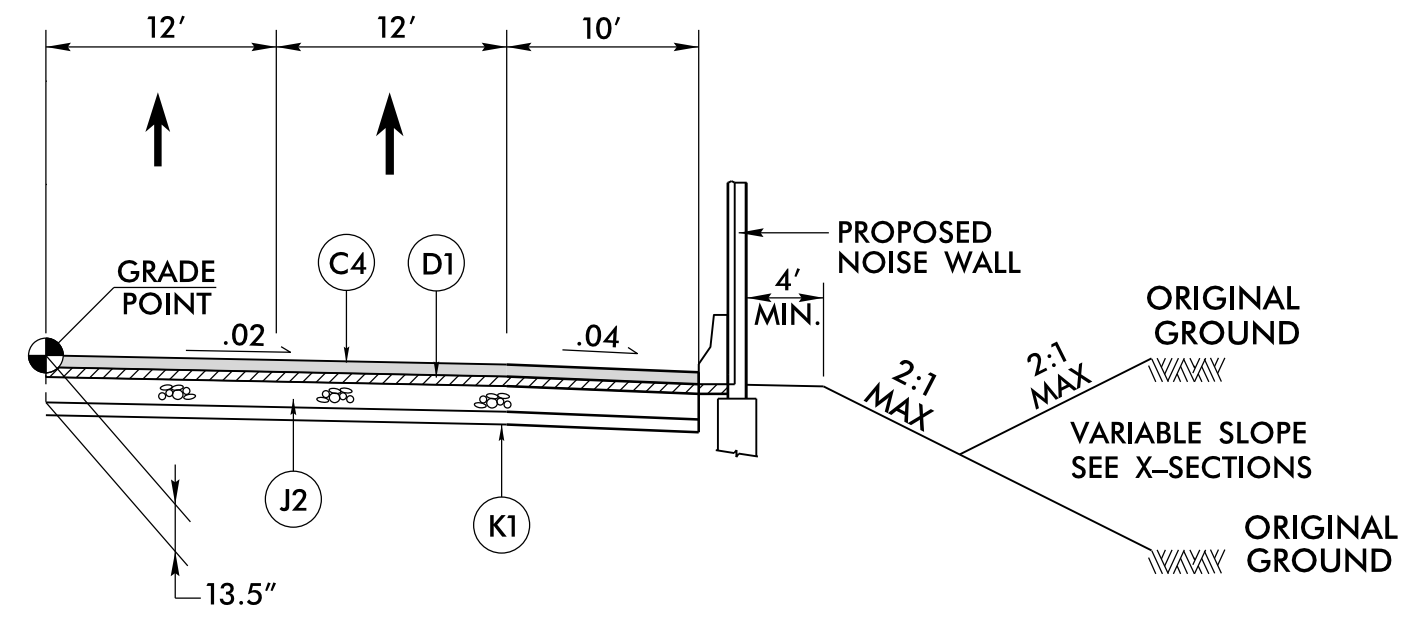

**DETAIL NO. 1 FOR NOISE WALLS**  
USE IN CONJUNCTION WITH -L3- TYPICAL SECTION No.1

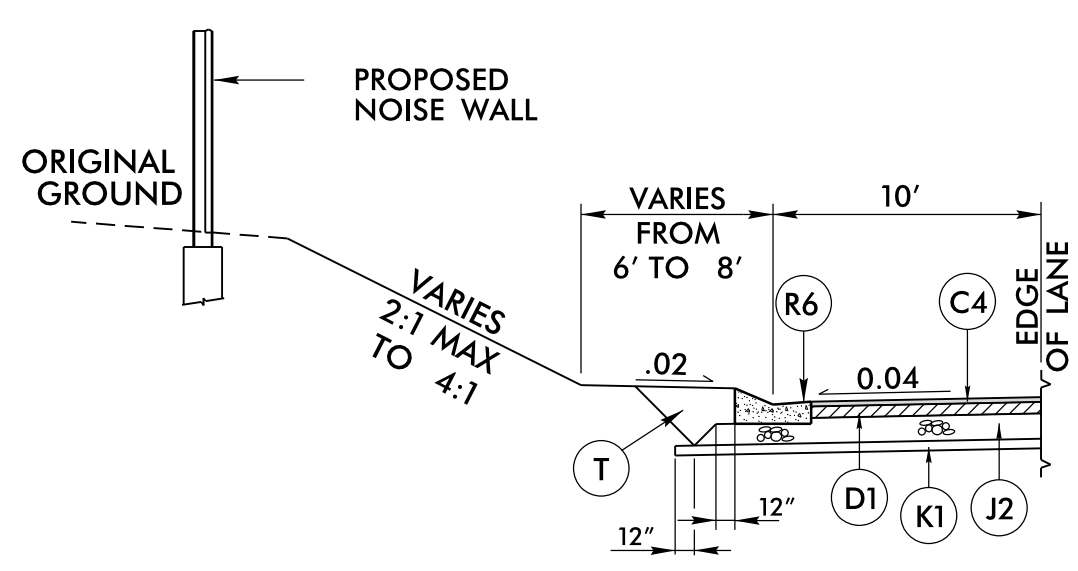

**DETAIL NO. 2 FOR NOISE WALLS**  
USE IN CONJUNCTION WITH -L3- TYPICAL SECTION No.1

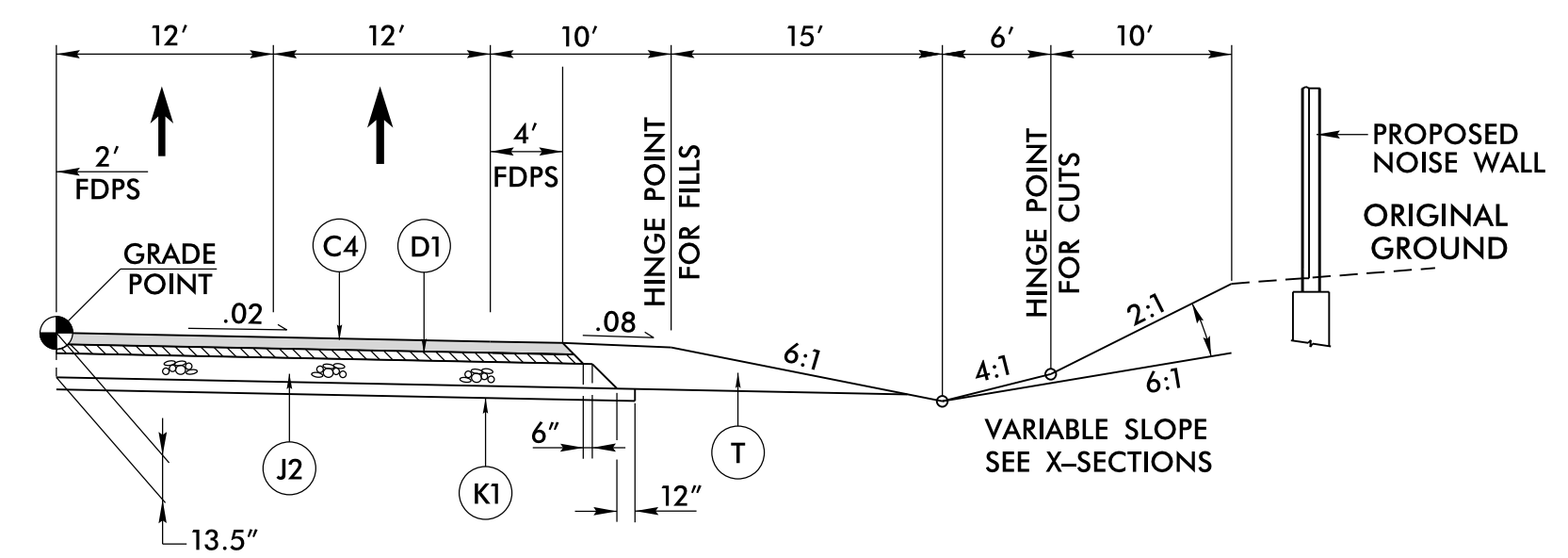

**DETAIL NO. 3 FOR NOISE WALLS**  
USE IN CONJUNCTION WITH -L3- TYPICAL SECTION No.1

6/2/2021

8/10/2021 3:24:40 PM  
R:\2233\338E\_R0Y\_TYP\_2A-3.DGN  
11:55:56 AM



6/2/2021

PAVEMENT SCHEDULE (FINAL)

ITEM	DESCRIPTION	ITEM	DESCRIPTION	ITEM	DESCRIPTION	ITEM	DESCRIPTION	ITEM	DESCRIPTION	ITEM	DESCRIPTION	ITEM	DESCRIPTION	ITEM	DESCRIPTION				
(A1)	7" CONCRETE	(C4)	3" S9.5C	(D3)	VAR DEPTH I19.0C	(E4)	5" B25.0C	(K1)	CHEMICAL STABILIZATION: 7" SOIL-CEMENT BASE OR 8" LIME-TREATED SOIL	(R1)	2'-6" CONCRETE CURB & GUTTER	(R5)	8"x12" CONCRETE CURB	(U)	EXIST. PAVEMENT				
(C1)	1.5" S9.5B	(C5)	VAR DEPTH S9.5C	(E1)	3" B25.0C	(E5)	VAR DEPTH B25.0C	(K2)	8" CLASS IV SUBGRADE STABILIZATION	(R2)	SHOULDER BERM GUTTER	(R6)	CONCRETE EXPRESSWAY GUTTER	(Z)	MILLED RUMBLE STRIP				
(C2)	3" S9.5B	(D1)	2.5" I19.0C	(E2)	4" B25.0C	(J1)	6" ABC	(N1)	GEOTEXTILE FOR SOIL STABILIZATION	(R3)	5" CONC. ISLAND	(S)	4" CONC. SIDEWALK	(V1)	(V2)	(V3)	(V4)	PAVEMENT MILLING	
(C3)	VAR DEPTH S9.5B	(D2)	4" I19.0C	(E3)	4.5" B25.0C	(J2)	8" ABC	(N2)	GEOTEXTILE FOR PAVEMENT STABILIZATION	(P)	PRIME COAT	(R4)	2' MODIFIED VALLEY GUTTER	(T)	EARTH	(W1)	(W2)	(W3)	VARIABLE DEPTH PAVEMENT WEDGING

PROJECT REFERENCE NO. R-2233BB	SHEET NO. 2A-4
ROADWAY DESIGN ENGINEER 	PAVEMENT DESIGN ENGINEER 
<b>DOCUMENT NOT CONSIDERED FINAL UNLESS ALL SIGNATURES COMPLETED</b>	
 2510 WYCLIFF ROAD RALEIGH, NC 27607 PHONE: 919.881.9739 NC O&A No. F-08029	
NC DEPARTMENT OF TRANSPORTATION PAVEMENT MANAGEMENT UNIT 1593 MAIL SERVICE CENTER RALEIGH, NC 27699-1593	

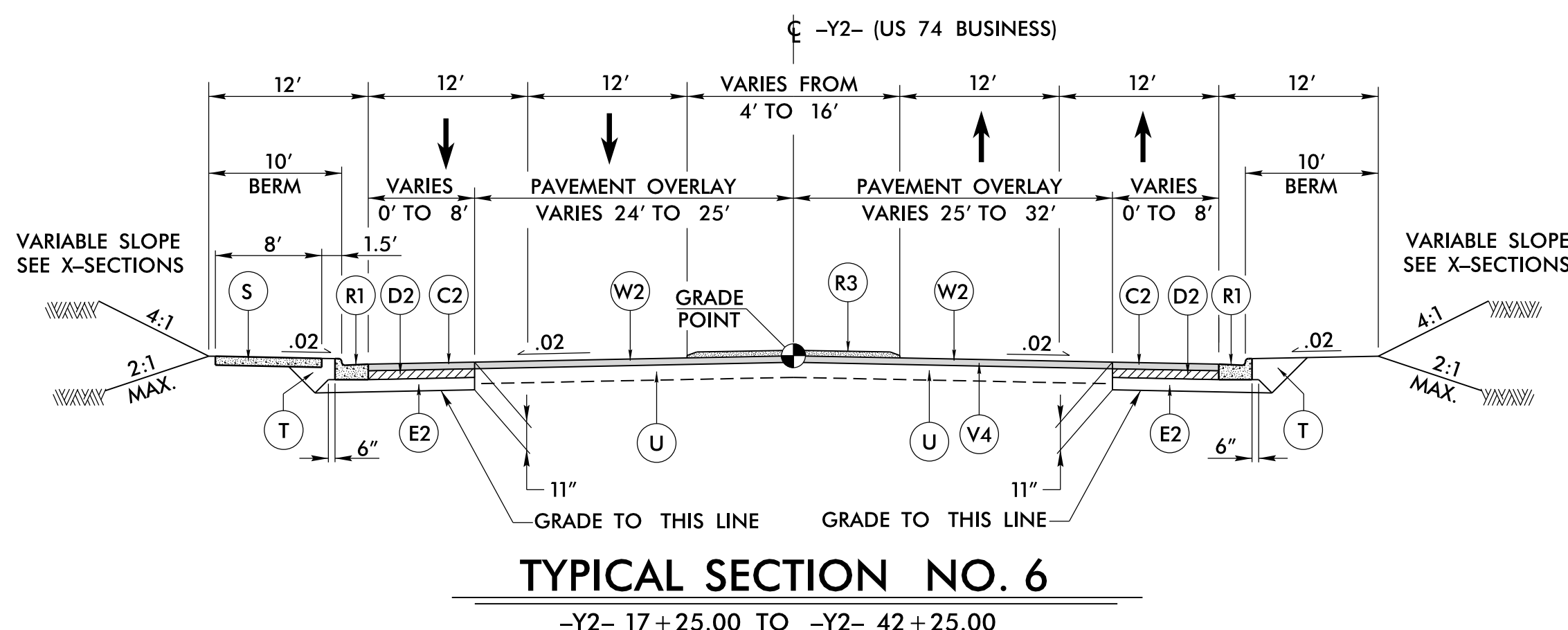

**TYPICAL SECTION NO. 6**  
-Y2- 17+25.00 TO -Y2- 42+25.00

**PROPOSED RETAINING WALL**  
-Y2- 27+67+/- TO -Y2- 31+45+/- - EASTBOUND  
-Y2- 28+41+/- TO -Y2- 30+91+/- - WESTBOUND  
NOTE: SIDEWALK ON WESTBOUND SIDE ONLY.  
SEE BRIDGE PLANS FOR WALL LOCATION & DETAILS

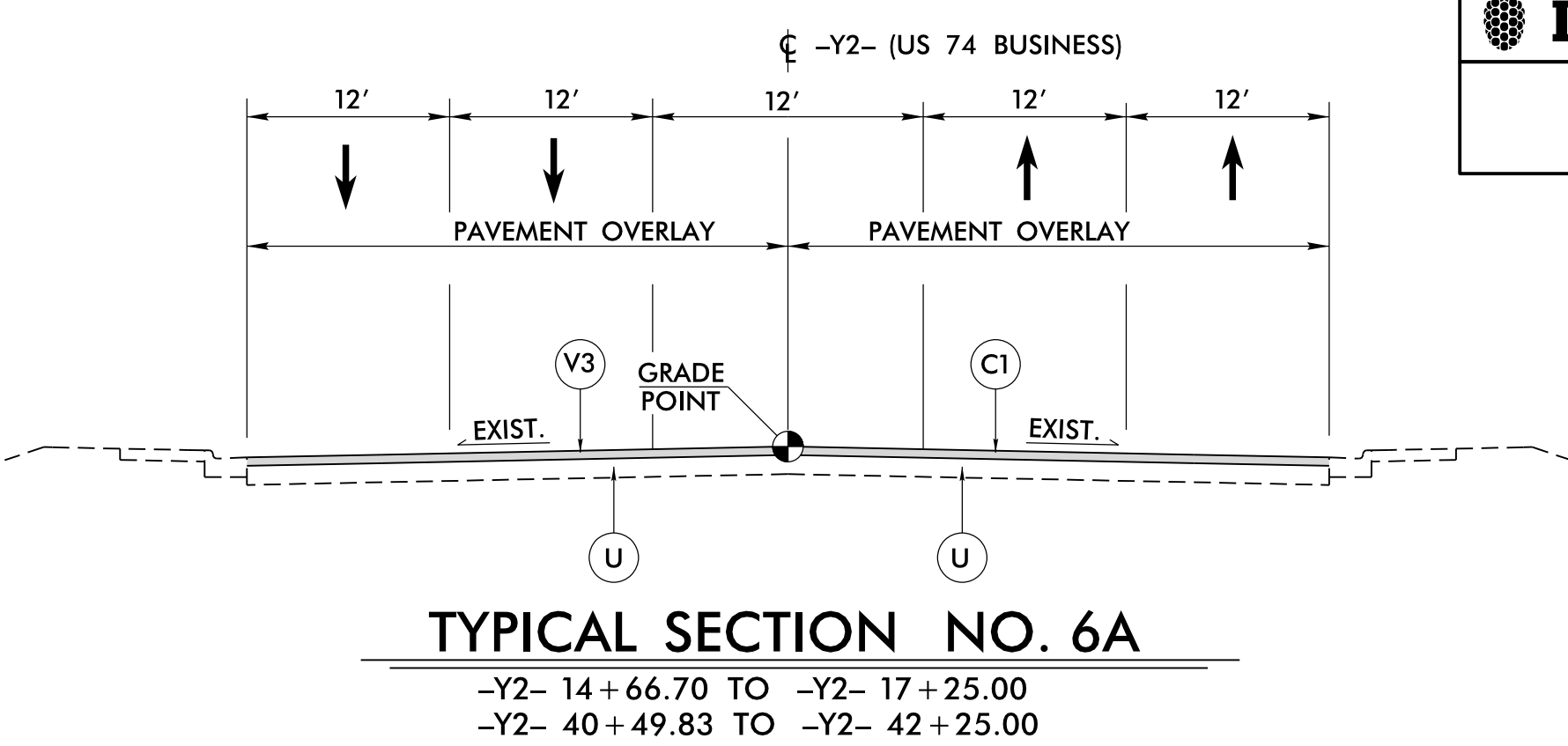

**TYPICAL SECTION NO. 6A**  
-Y2- 14+66.70 TO -Y2- 17+25.00  
-Y2- 40+49.83 TO -Y2- 42+25.00

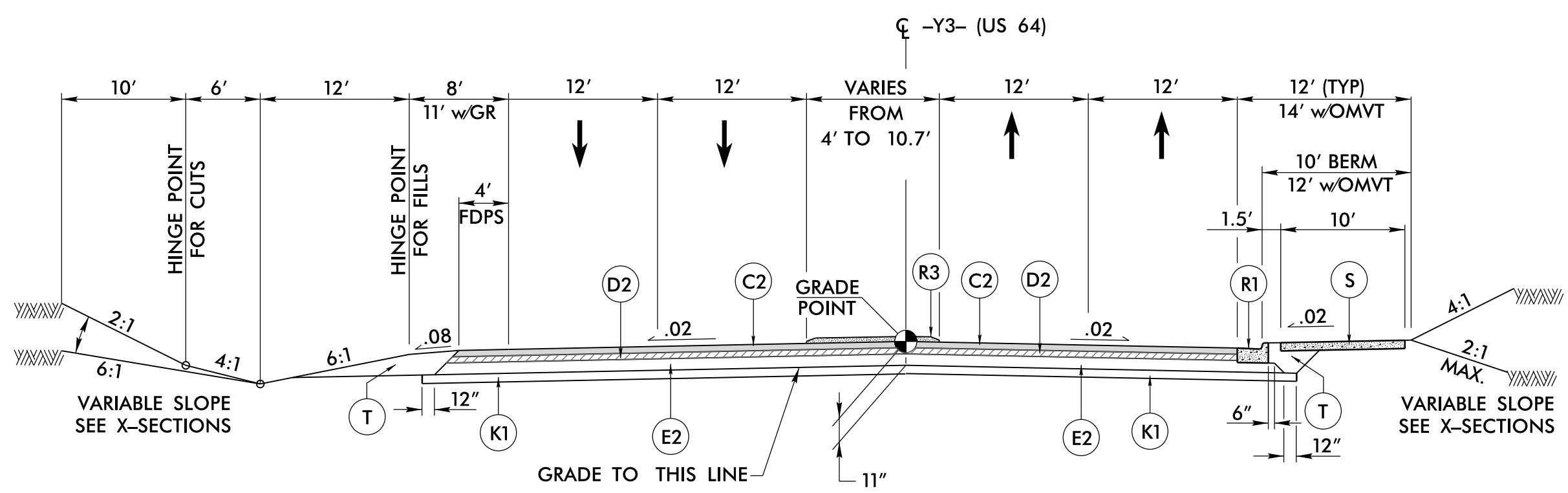

**TYPICAL SECTION NO. 7**  
**WESTBOUND LANES**  
-Y3- 14+75.00 TO -Y3- 25+40.52 BRIDGE  
-Y3- 27+69.52 BRIDGE TO -Y3- 37+25.00

**TYPICAL SECTION NO. 7**  
**EASTBOUND LANES**  
-Y3- 14+75.00 TO -Y3- 25+40.52 BRIDGE  
-Y3- 27+69.52 BRIDGE TO -Y3- 32+05.00  
(SEE DETAIL FOR OMTV THIS SHEET)

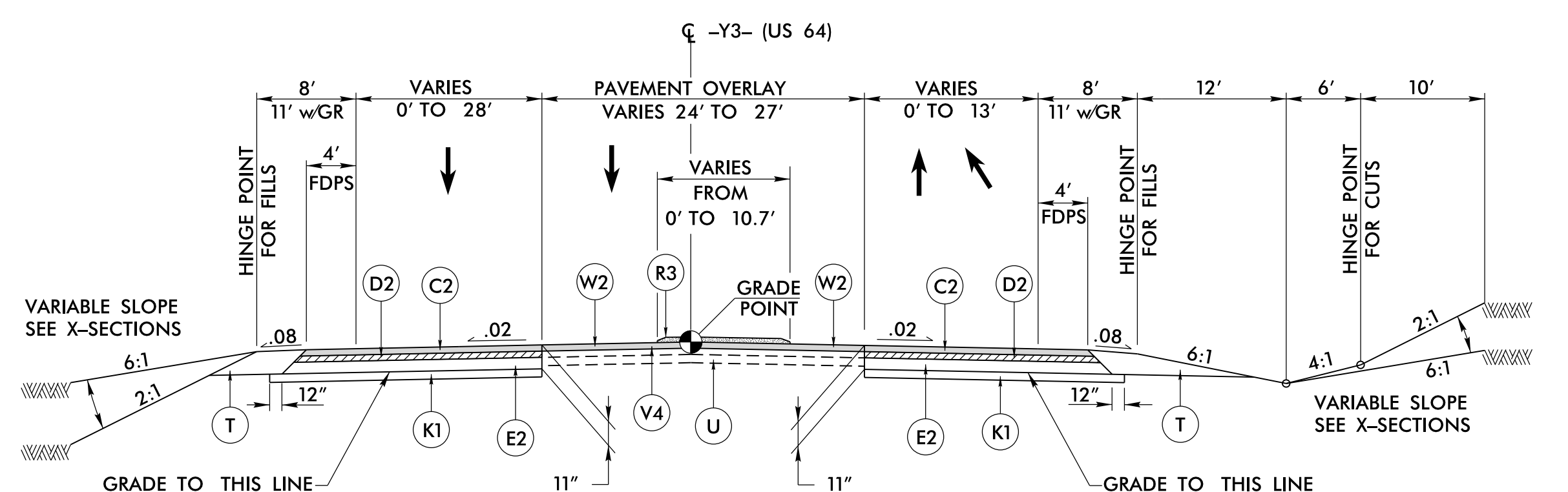

**TYPICAL SECTION NO. 7A**  
**WESTBOUND LANES**  
-Y3- 13+10.00 TO -Y3- 14+75.00  
-Y3- 37+25.00 TO -Y3- 41+50.00

**TYPICAL SECTION NO. 7A**  
**EASTBOUND LANES**  
-Y3- 13+10.00 TO -Y3- 14+75.00  
-Y3- 33+96.00 TO -Y3- 39+88.56  
-Y3- 40+67.67 TO -Y3- 41+50.00

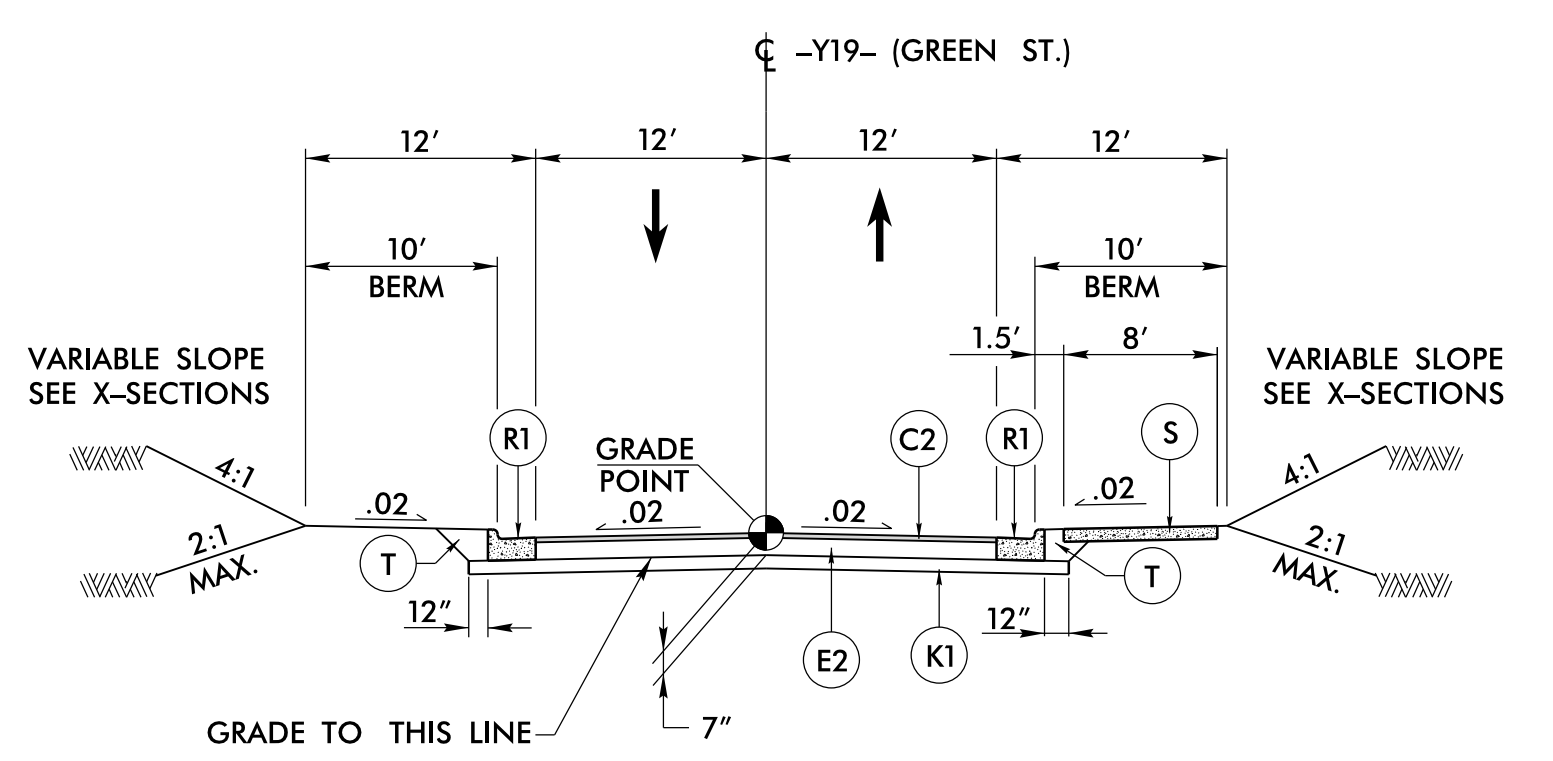

**TYPICAL SECTION NO. 8**  
-Y19- 12+75.00 TO -Y19- 20+03.44 (BRIDGE)  
-Y19- 21+84.94 (BRIDGE) TO -Y19- 28+50.00

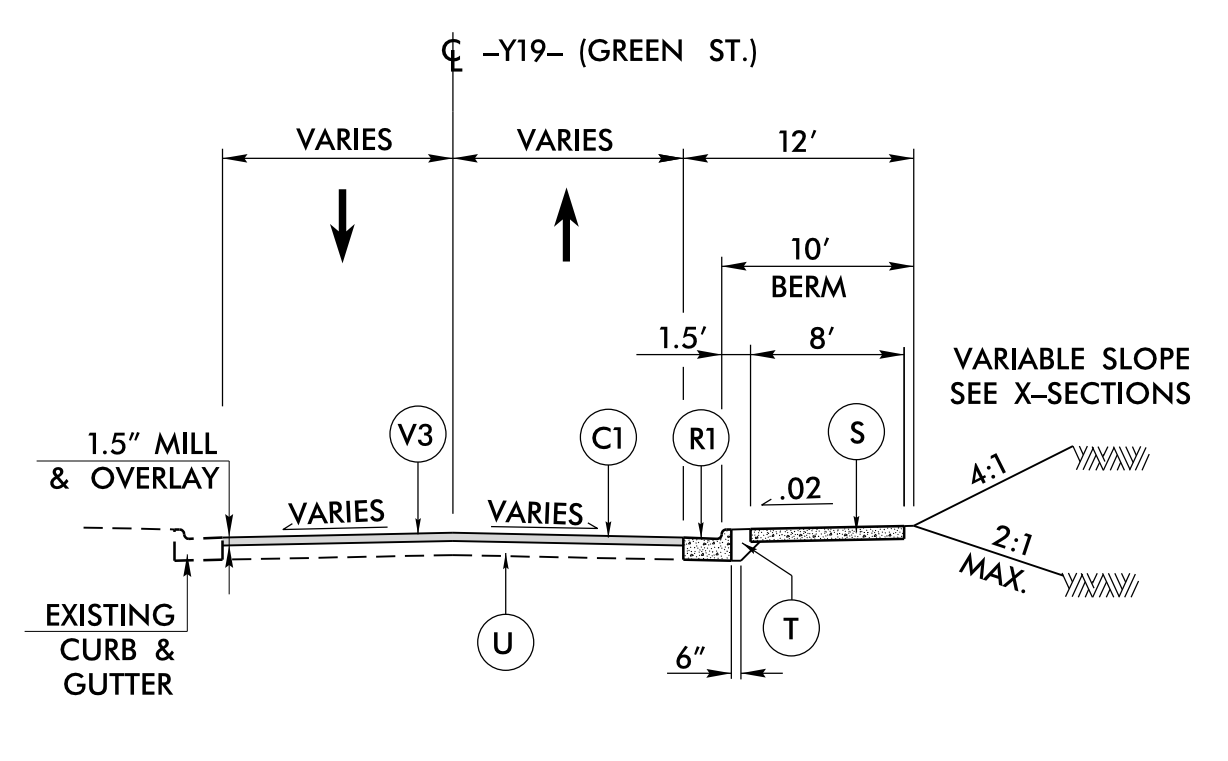

**TYPICAL SECTION NO. 8A**  
-Y19- 6+75.00 TO -Y19- 12+75.00 SIDEWALK - RIGHT  
-Y19- 28+50.00 TO -Y19- 30+20.73 CURB & GUTTER /NO SIDEWALK - LEFT

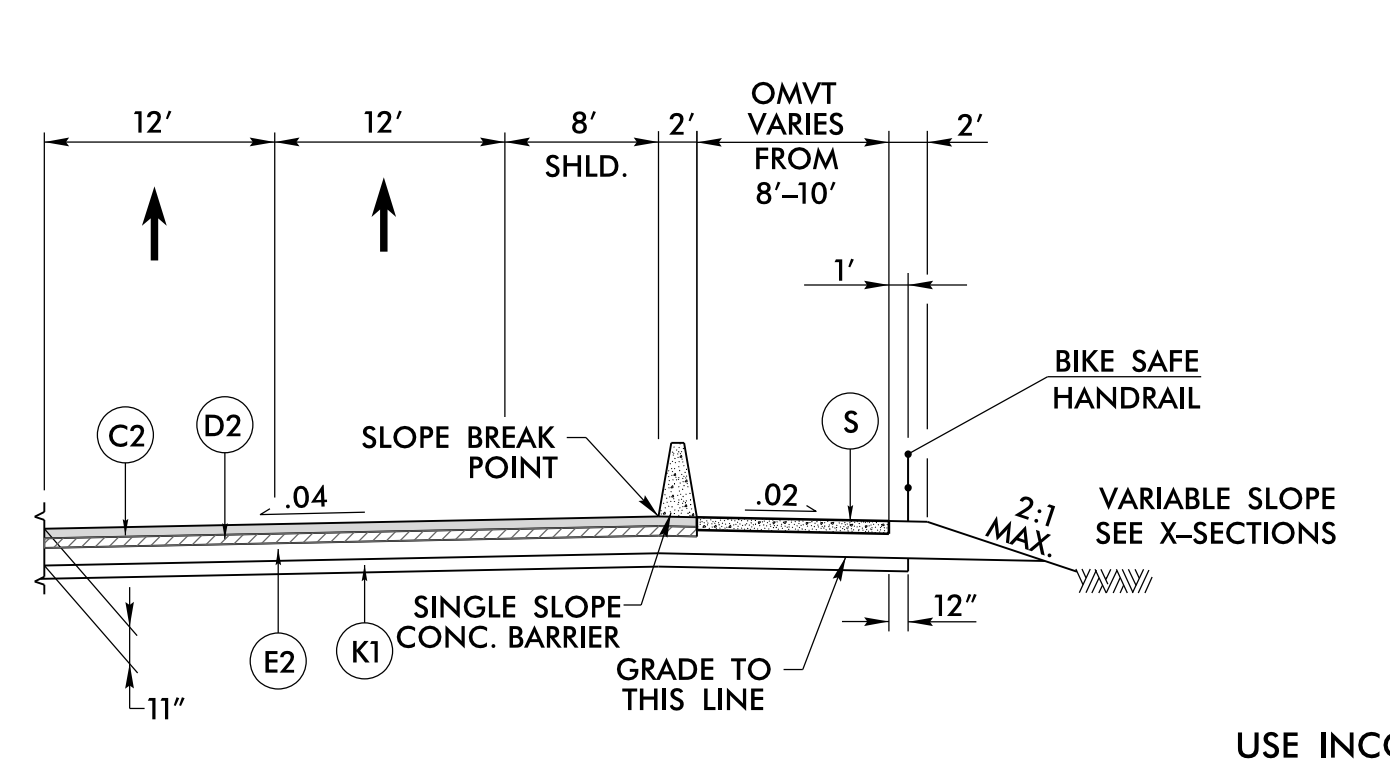

**OVER MOUNTAIN VICTORY TRAIL (OMVT)**  
**-Y3- EASTBOUND LANES**  
-Y3- 21+60.55 TO -Y3- 25+12.73 APPROACH SLAB  
-Y3- 27+86.31 APPROACH SLAB TO -Y3- 32+05.00

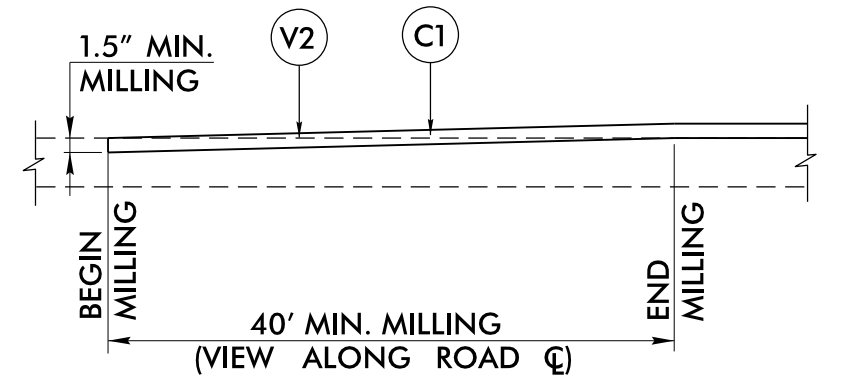

**INCIDENTAL MILLING DETAIL - V2**  
USE INCONJUNCTION WITH ALL -Y- LINE TIE-INS  
-Y3- 13+10.00 TO -Y3- 13+50.00  
-Y3- 41+10.00 TO -Y3- 41+50.00

USE INCONJUNCTION WITH TS No. 7  
-Y3- 21+52.58 TO -Y3- 31+35.00 (CONCRETE BARRIER)  
-Y3- 22+00.00 TO -Y3- 25+40.52 BRIDGE (BIKE SAFE HANDRAIL-RIGHT)  
-Y3- 27+69.52 BRIDGE TO -Y3- 31+35.00 (BIKE SAFE HANDRAIL-RIGHT)  
-Y3- 24+50.00 TO -Y3- 25+10.00 WIDTH VARIES FROM 10' TO 8'  
-Y3- 27+84.00 TO -Y3- 28+50.00 WIDTH VARIES FROM 8' TO 10'  
SIDEWALK WIDTH IS 8' ON THE PROPOSED BRIDGE.  
SEE CROSS SECTIONS & BRIDGE PLANS.

9/26/2021 11:36:14 AM  
ITS:FCOJNR2233BB.RDY..TYP..2A-4.DGN

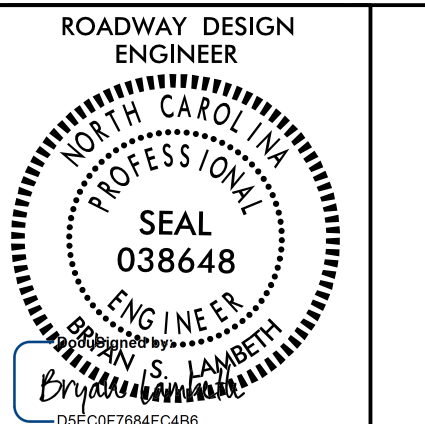

PAVEMENT SCHEDULE (FINAL)

PROJECT REFERENCE NO. R-2233BB	SHEET NO. 2A-5
ROADWAY DESIGN ENGINEER DENNIS J. MORY PE# 020031 ON 8/25/2021	PAVEMENT DESIGN ENGINEER SEAL 024964 DENNIS J. MORY
NOT A CERTIFIED DOCUMENT AS TO THE ORIGINAL DOCUMENT BUT ONLY AS TO THE REVISIONS. THIS DOCUMENT ORIGINALLY ISSUED AND SEALED BY: DENNIS J. MORY PE# 020031 ON 8/25/2021 THIS DOCUMENT IS ONLY CERTIFIED AS TO THE REVISIONS.	
<b>DOCUMENT NOT CONSIDERED FINAL UNLESS ALL SIGNATURES COMPLETED</b>	
 2410 WYCLIFF ROAD SUITE 410 RALEIGH, NC 27607 PHONE: 919.881.9959 NC REG. NO. F-0929	
 ROADWAY DESIGN ENGINEER SEAL 038648 DENNIS J. MORY DSE#007884FC488	

ITEM	DESCRIPTION	ITEM	DESCRIPTION	ITEM	DESCRIPTION	ITEM	DESCRIPTION	ITEM	DESCRIPTION	ITEM	DESCRIPTION	ITEM	DESCRIPTION	ITEM	DESCRIPTION				
(A1)	7" CONCRETE	(C4)	3" S9.5C	(D3)	VAR DEPTH I19.0C	(E4)	5" B25.0C	(K1)	CHEMICAL STABILIZATION: 7" SOIL-CEMENT BASE OR 8" LIME-TREATED SOIL	(R1)	2'-6" CONCRETE CURB & GUTTER	(R5)	8"x12" CONCRETE CURB	(U)	EXIST. PAVEMENT				
(C1)	1.5" S9.5B	(C5)	VAR DEPTH S9.5C	(E1)	3" B25.0C	(E5)	VAR DEPTH B25.0C	(K2)	8" CLASS IV SUBGRADE STABILIZATION	(R2)	SHOULDER BERM GUTTER	(R6)	CONCRETE EXPRESSWAY GUTTER	(Z)	MILLED RUMBLE STRIP				
(C2)	3" S9.5B	(D1)	2.5" I19.0C	(E2)	4" B25.0C	(J1)	6" ABC	(N1)	GEOTEXTILE FOR SOIL STABILIZATION	(R3)	5" CONC. ISLAND	(S)	4" CONC. SIDEWALK	(V1)	(V2)	(V3)	(V4)	PAVEMENT MILLING	
(C3)	VAR DEPTH S9.5B	(D2)	4" I19.0C	(E3)	4.5" B25.0C	(J2)	8" ABC	(N2)	GEOTEXTILE FOR PAVEMENT STABILIZATION	(P)	PRIME COAT	(R4)	2' MODIFIED VALLEY GUTTER	(T)	EARTH	(W1)	(W2)	(W3)	VARIABLE DEPTH PAVEMENT WEDGING

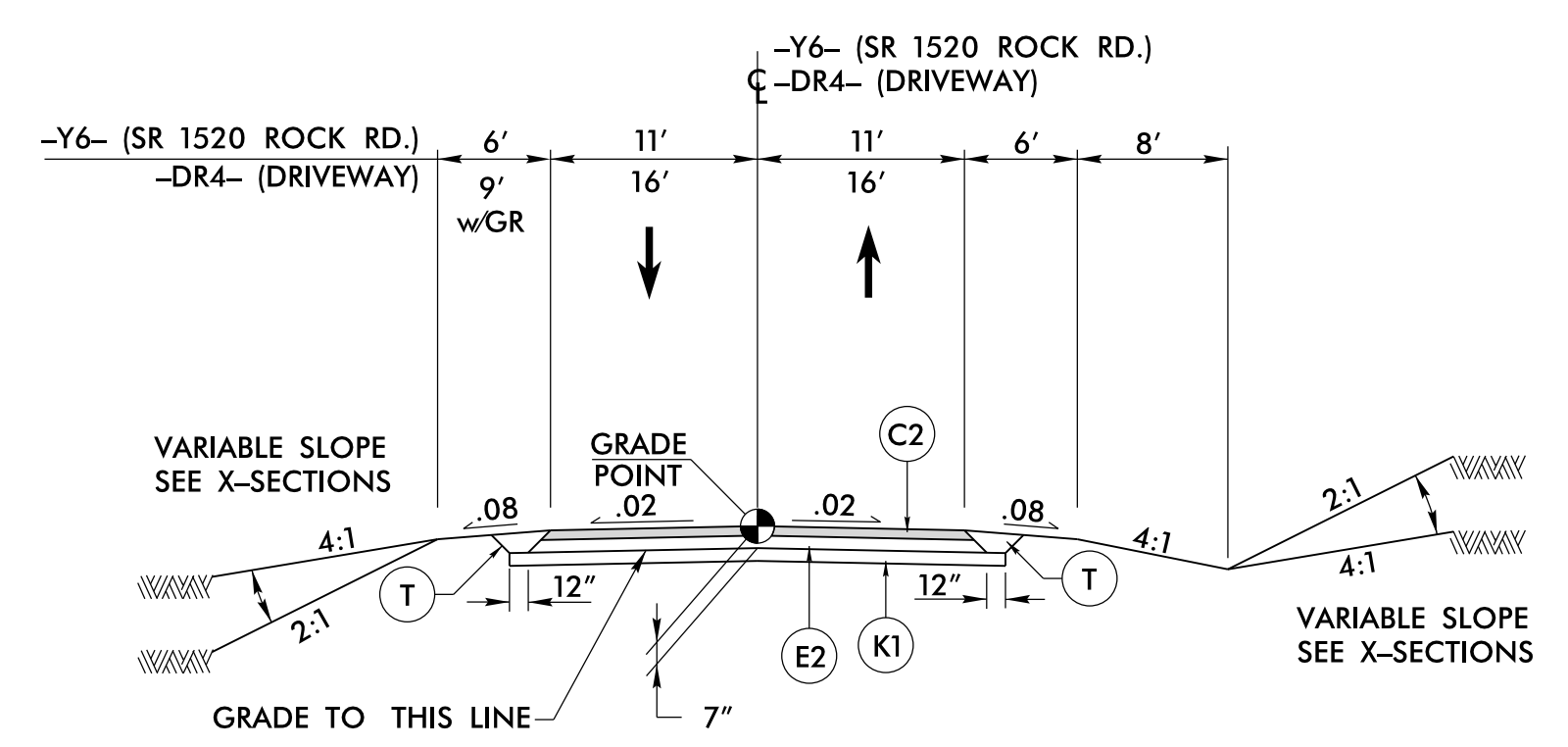

**TYPICAL SECTION NO. 9**

-Y6- 10+00.00 TO -Y6- 25+92.57  
 -Y6- 26+12.41 TO -Y6- 33+21.90  
 -DR4- 12+00.00 TO -DR4- 14+17.87  
 NOTE - STABILIZATION NOT REQUIRED FOR DRIVEWAY -DR4-

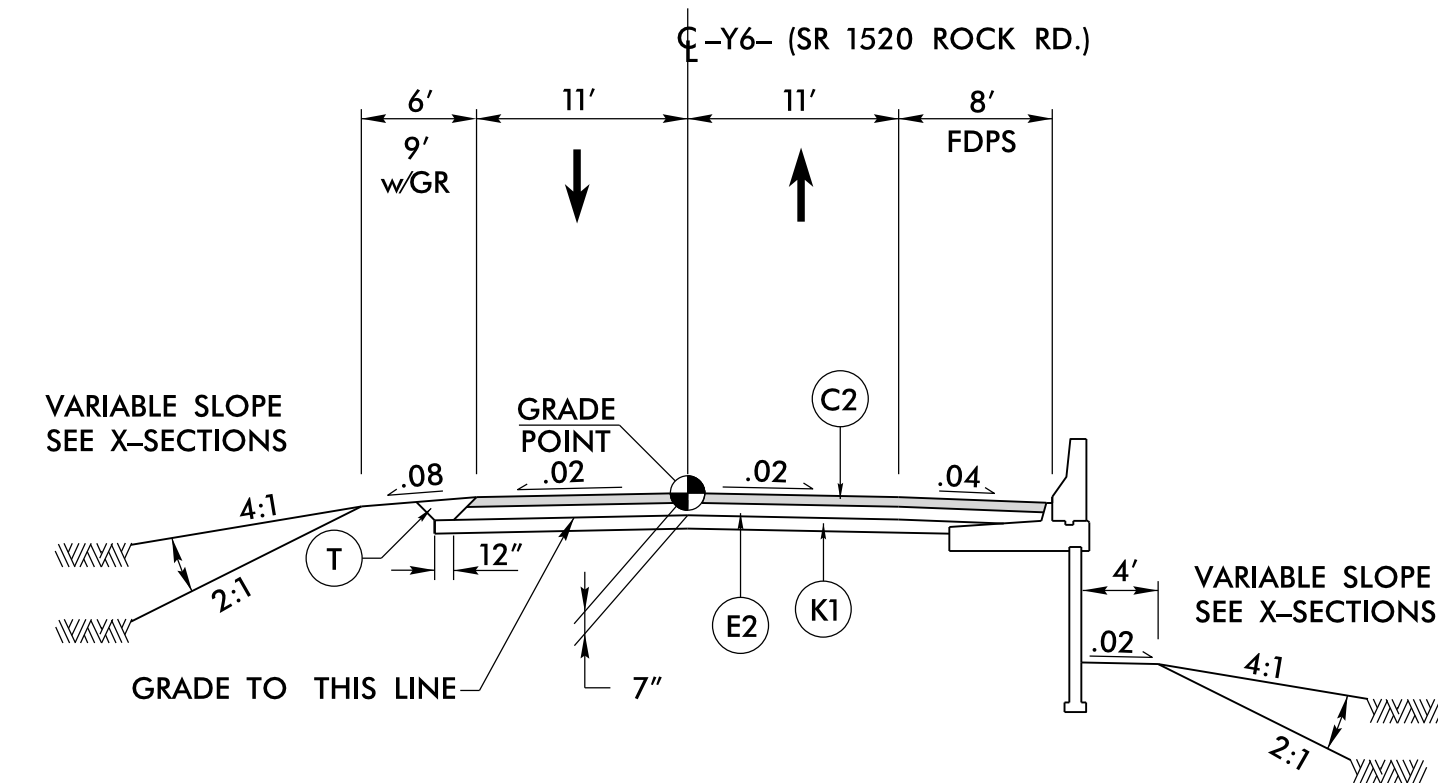

**TYPICAL SECTION NO. 9A**

-Y6- 26+60.00 TO -Y6- 27+11.00 - RIGHT  
 -Y6- 26+25.06 TO -Y6- 26+64.31 (FDPS - RIGHT)

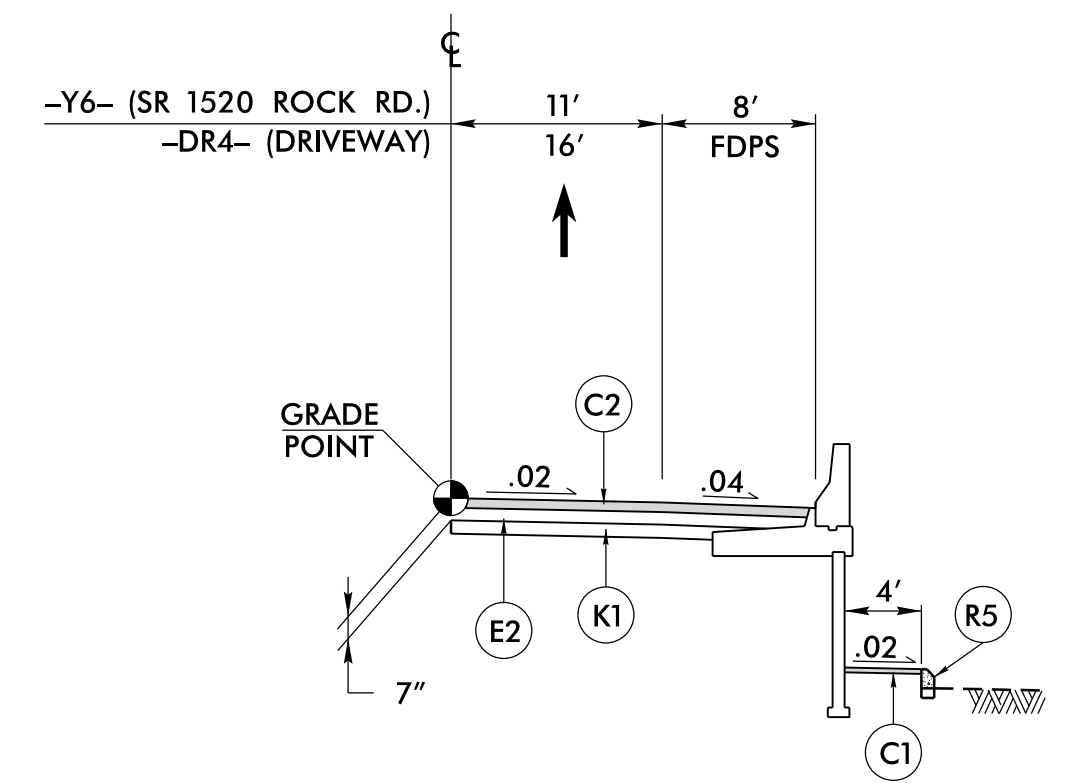

**TYPICAL SECTION NO. 9B**

-Y6- 27+11.00 TO -Y6- 26+60.00 - RIGHT  
 -DR4 13+14.00 TO 13+97.10 - LEFT  
 NOTE - STABILIZATION NOT REQUIRED FOR DRIVEWAY -DR4-

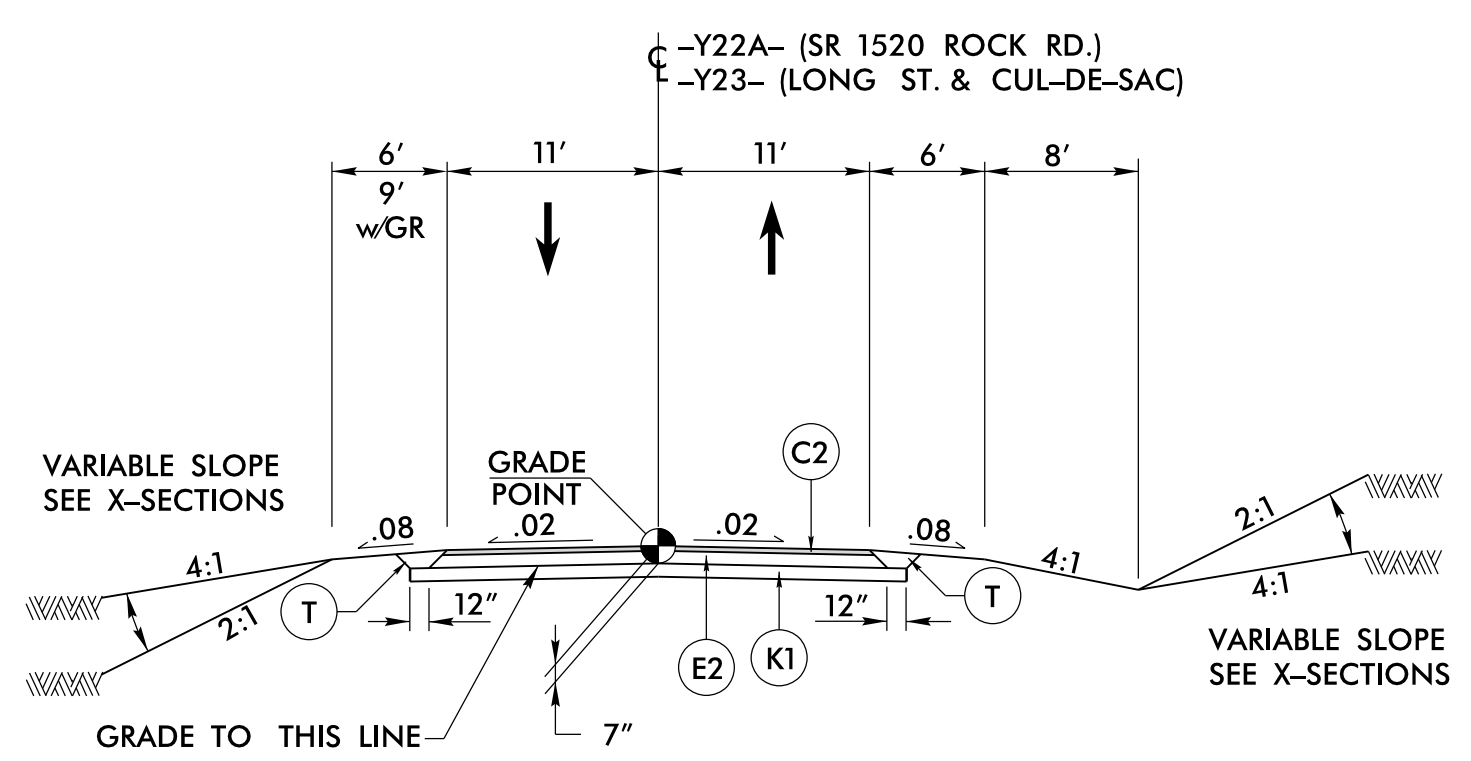

**TYPICAL SECTION NO. 10**

-Y22A- 34+50.00 TO -Y22A- 40+24.15  
 -Y23- 36+60.00 TO -Y23- 39+33.33

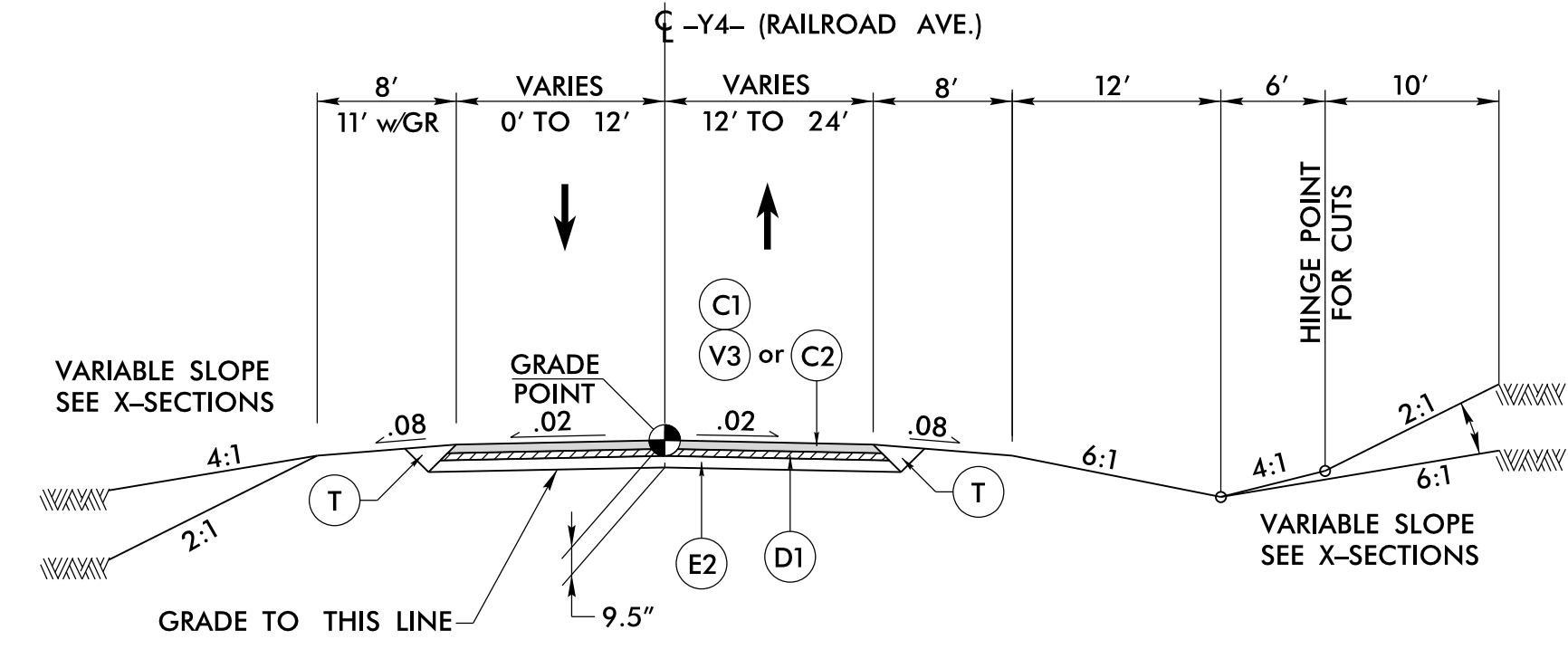

**TYPICAL SECTION NO. 11**

-Y4- 17+00.00 TO -Y4- 18+50.00 - LEFT (MILL & OVERLAY)  
 -Y4- 18+50.00 TO -Y4- 23+45.84

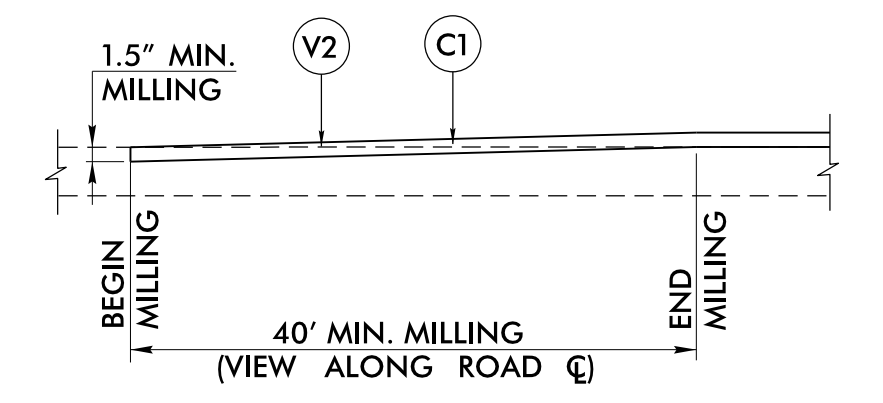

**INCIDENTAL MILLING DETAIL - V2**  
 USE IN CONJUNCTION WITH ALL -Y- LINE TIE-INS  
 -Y23- 36+60.00 TO -Y23- 37+00.00

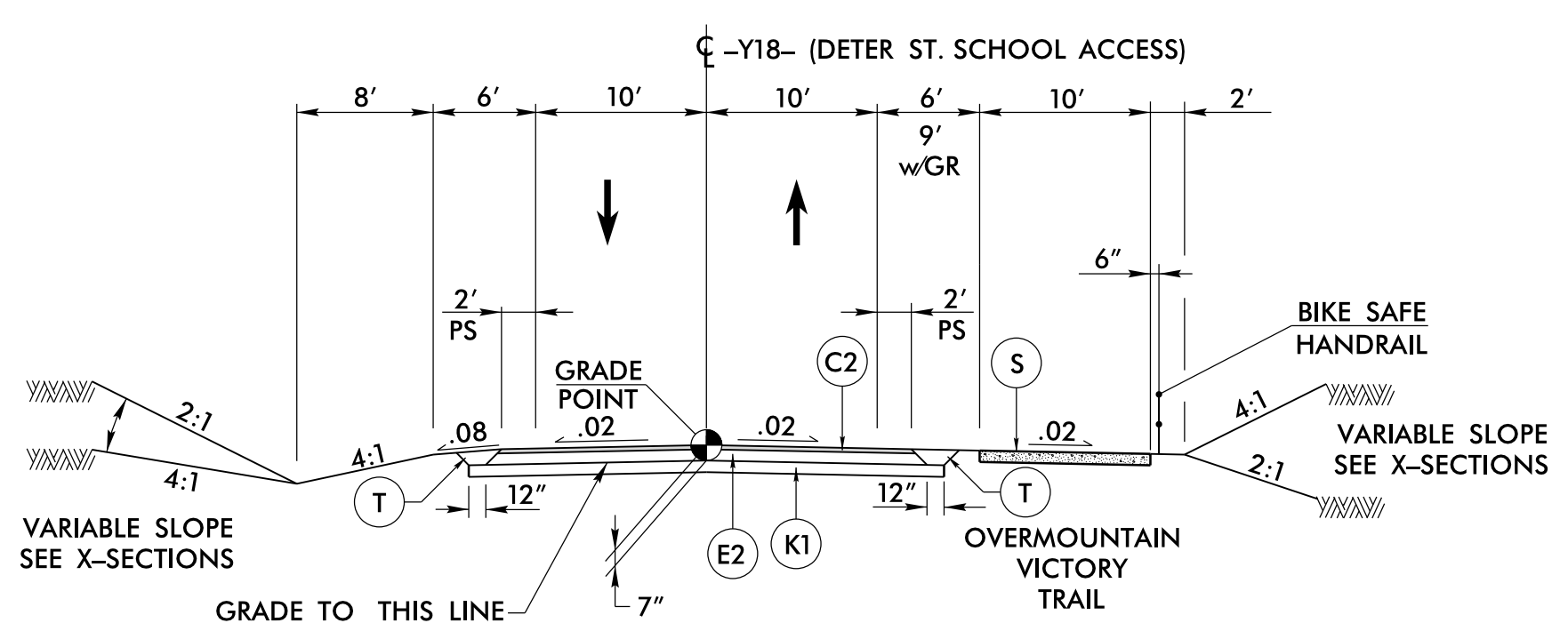

**TYPICAL SECTION NO. 12**

-Y18- 14+30.00 TO -Y18- 18+11.97  
 -Y18- 15+50.00 TO -Y18- 16+50.00 - RIGHT w/HANDRAIL

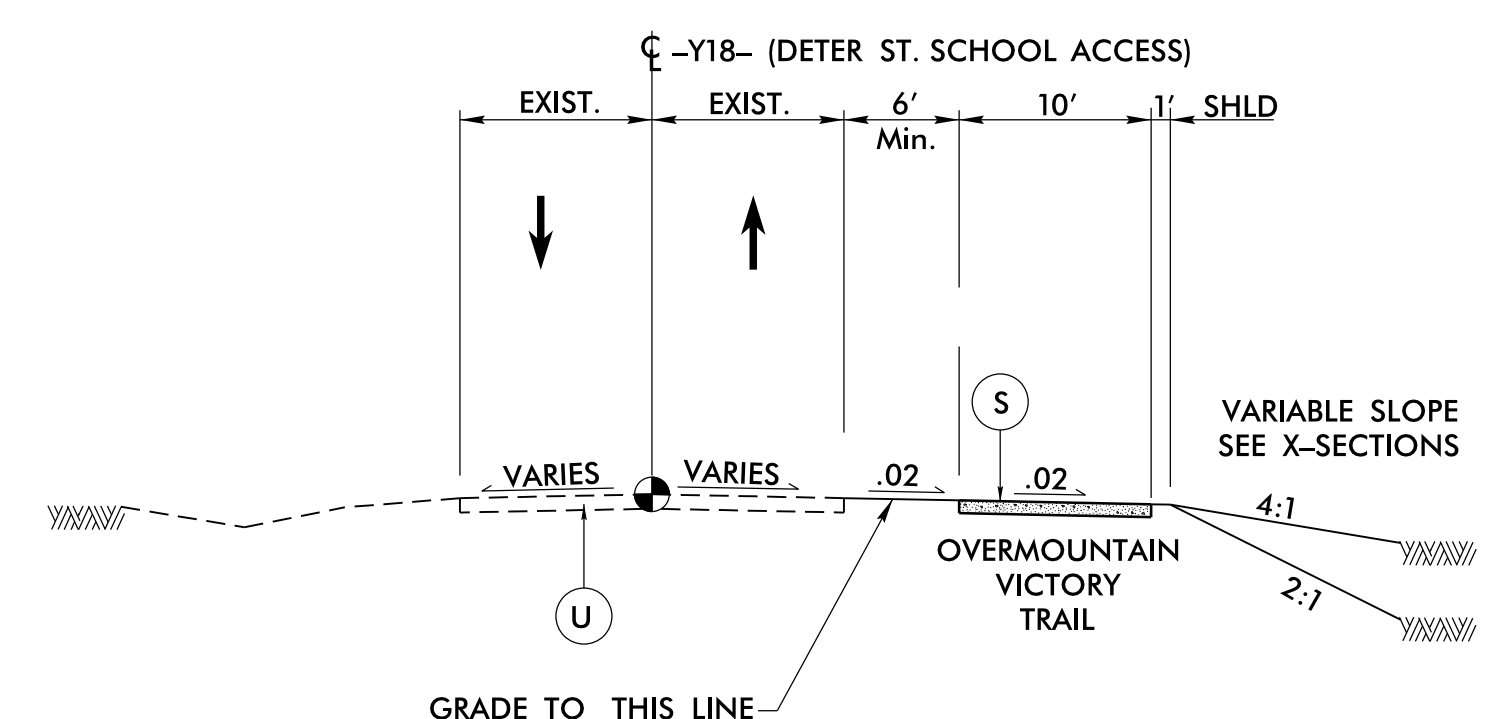

**TYPICAL SECTION NO. 12A**

-Y18- 10+30.42 TO -Y18- 14+30.00

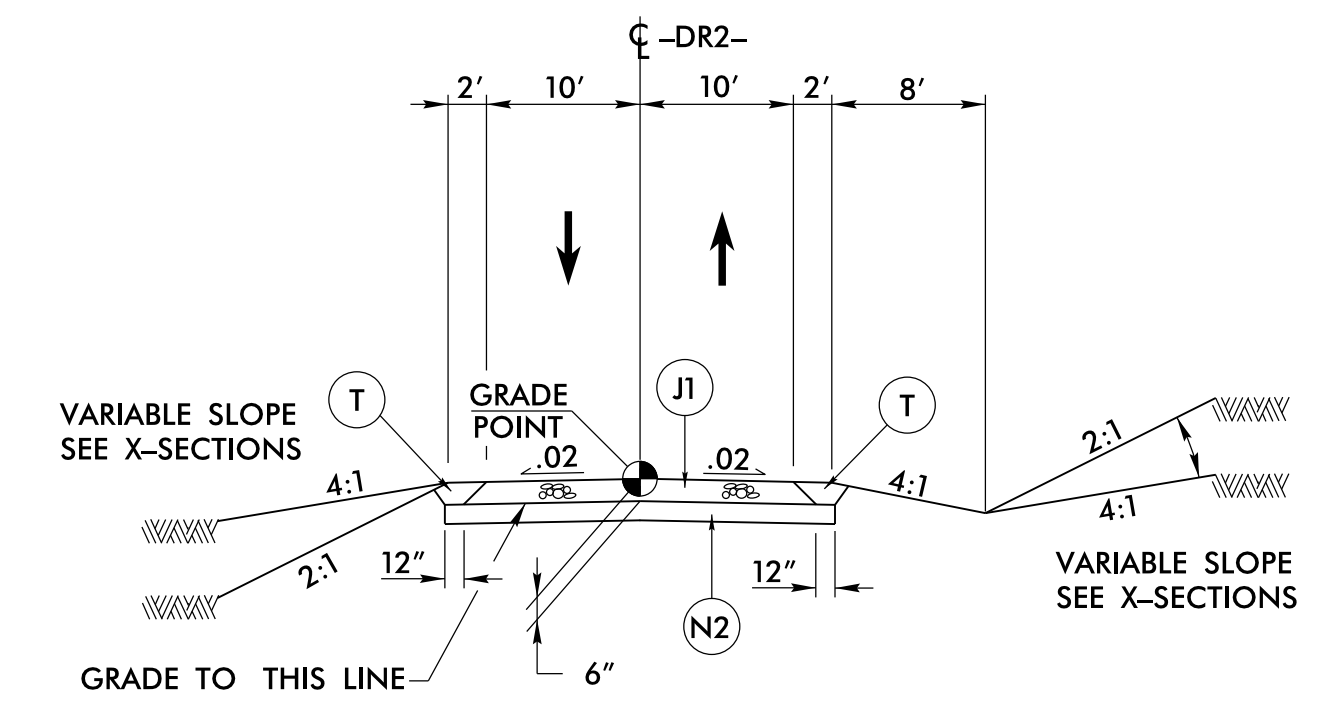

**TYPICAL SECTION NO. 13**

-DR2- 9+67.72 TO -DR2- 19+44.66

REVISIONS  
 CONSTRUCTION REV. - APRIL 29, 2022 - Removed -DR3- from typical section 13 and moved typical 13 to this sheet.

4/28/2022 12:51 PM  
 R-2233BB\_P01\_TYP\_2A-5.DGN  
 11:55:16 AM



### PAVEMENT SCHEDULE (FINAL)

ITEM	DESCRIPTION	ITEM	DESCRIPTION	ITEM	DESCRIPTION	ITEM	DESCRIPTION	ITEM	DESCRIPTION	ITEM	DESCRIPTION	ITEM	DESCRIPTION	ITEM	DESCRIPTION				
(A1)	7" CONCRETE	(C4)	3" S9.5C	(D3)	VAR DEPTH I19.0C	(E4)	5" B25.0C	(K1)	CHEMICAL STABILIZATION: 7" SOIL-CEMENT BASE OR 8" LIME-TREATED SOIL	(R1)	2'-6" CONCRETE CURB & GUTTER	(R5)	8"x12" CONCRETE CURB	(U)	EXIST. PAVEMENT				
(C1)	1.5" S9.5B	(C5)	VAR DEPTH S9.5C	(E1)	3" B25.0C	(E5)	VAR DEPTH B25.0C	(K2)	8" CLASS IV SUBGRADE STABILIZATION	(R2)	SHOULDER BERM GUTTER	(R6)	CONCRETE EXPRESSWAY GUTTER	(Z)	MILLED RUMBLE STRIP				
(C2)	3" S9.5B	(D1)	2.5" I19.0C	(E2)	4" B25.0C	(J1)	6" ABC	(N1)	GEOTEXTILE FOR SOIL STABILIZATION	(R3)	5" CONC. ISLAND	(S)	4" CONC. SIDEWALK	(V1)	(V2)	(V3)	(V4)	PAVEMENT MILLING	
(C3)	VAR DEPTH S9.5B	(D2)	4" I19.0C	(E3)	4.5" B25.0C	(J2)	8" ABC	(N2)	GEOTEXTILE FOR PAVEMENT STABILIZATION	(P)	PRIME COAT	(R4)	2' MODIFIED VALLEY GUTTER	(T)	EARTH	(W1)	(W2)	(W3)	VARIABLE DEPTH PAVEMENT WEDGING

PROJECT REFERENCE NO. R-2233BB	SHEET NO. 2A-6
ROADWAY DESIGN ENGINEER DENNIS J. MORY PE# 020031 ON 8/25/2021	PAVEMENT DESIGN ENGINEER SEAL 024964 DENNIS J. MORY
DOCUMENT NOT CONSIDERED FINAL UNLESS ALL SIGNATURES COMPLETED	
 2410 WYCLIFF ROAD SUITE 410 RALEIGH, NC 27607 PHONE: 919.881.9939 NC REG. NO. F-0628	
NC DEPARTMENT OF TRANSPORTATION PAVEMENT MANAGEMENT UNIT 1593 MAIL SERVICE CENTER RALEIGH, NC 27699-1993	
ROADWAY DESIGN ENGINEER SEAL 038648 DENNIS J. MORY	

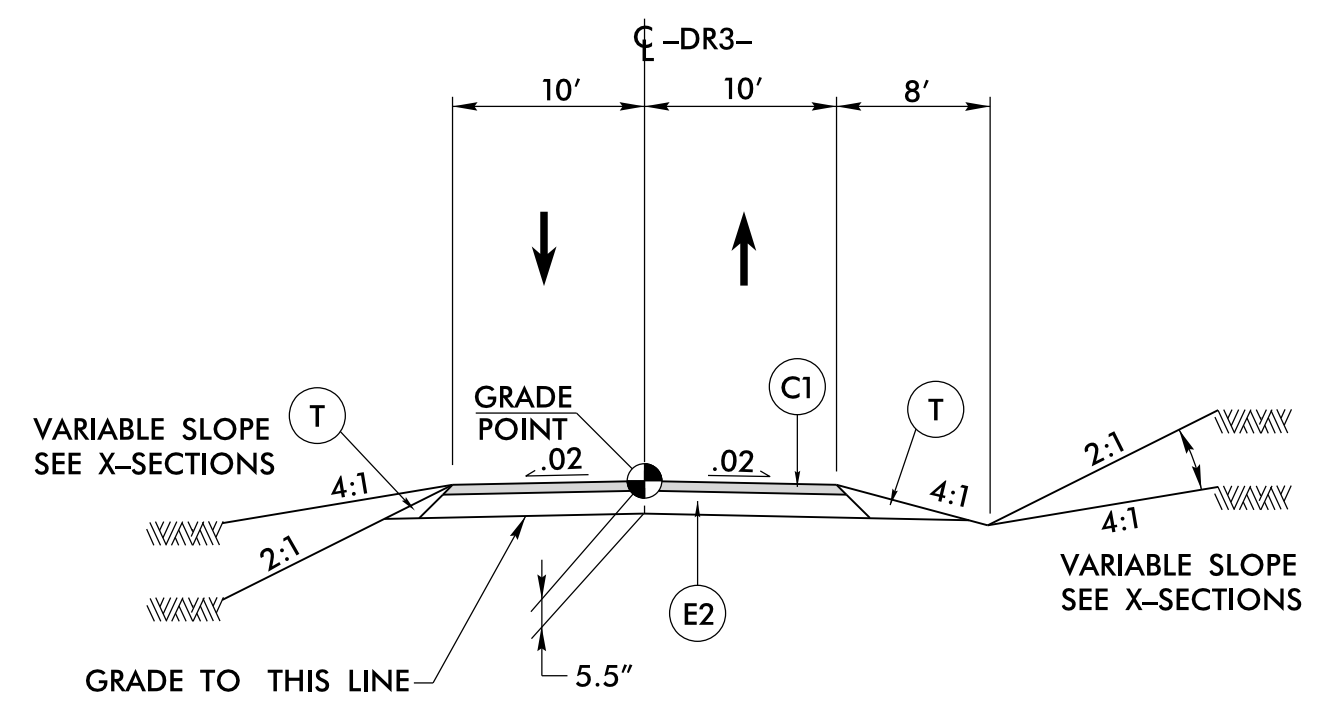

**TYPICAL SECTION NO. 13A**  
-DR3- 10+25.16 TO -DR3- 16+00.00

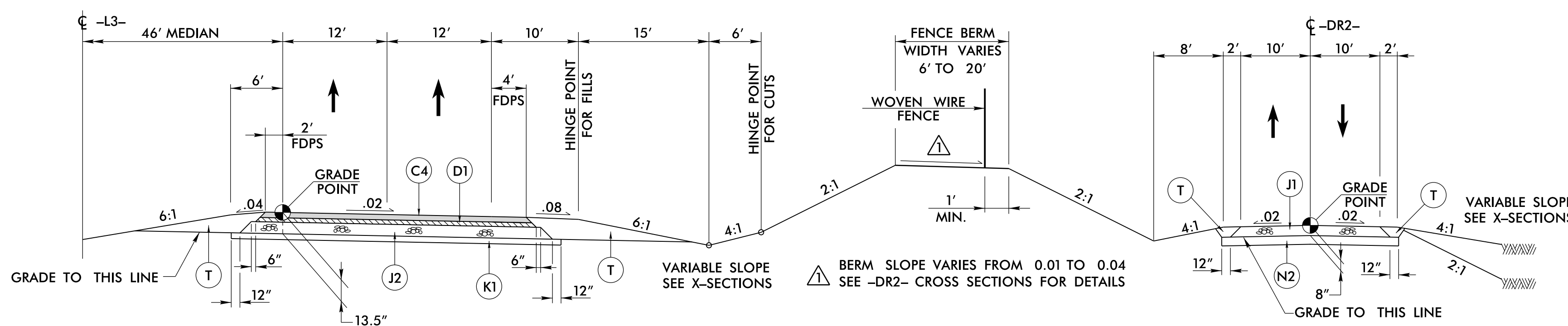

**TYPICAL SECTION 14**  
**WOVEN WIRE FENCE BERM DETAIL**  
-L3- 751+20.89 TO -L3- 759+00.00 NORTHBOUND LANES  
-DR2- 11+80.00 TO -DR2- 19+44.00

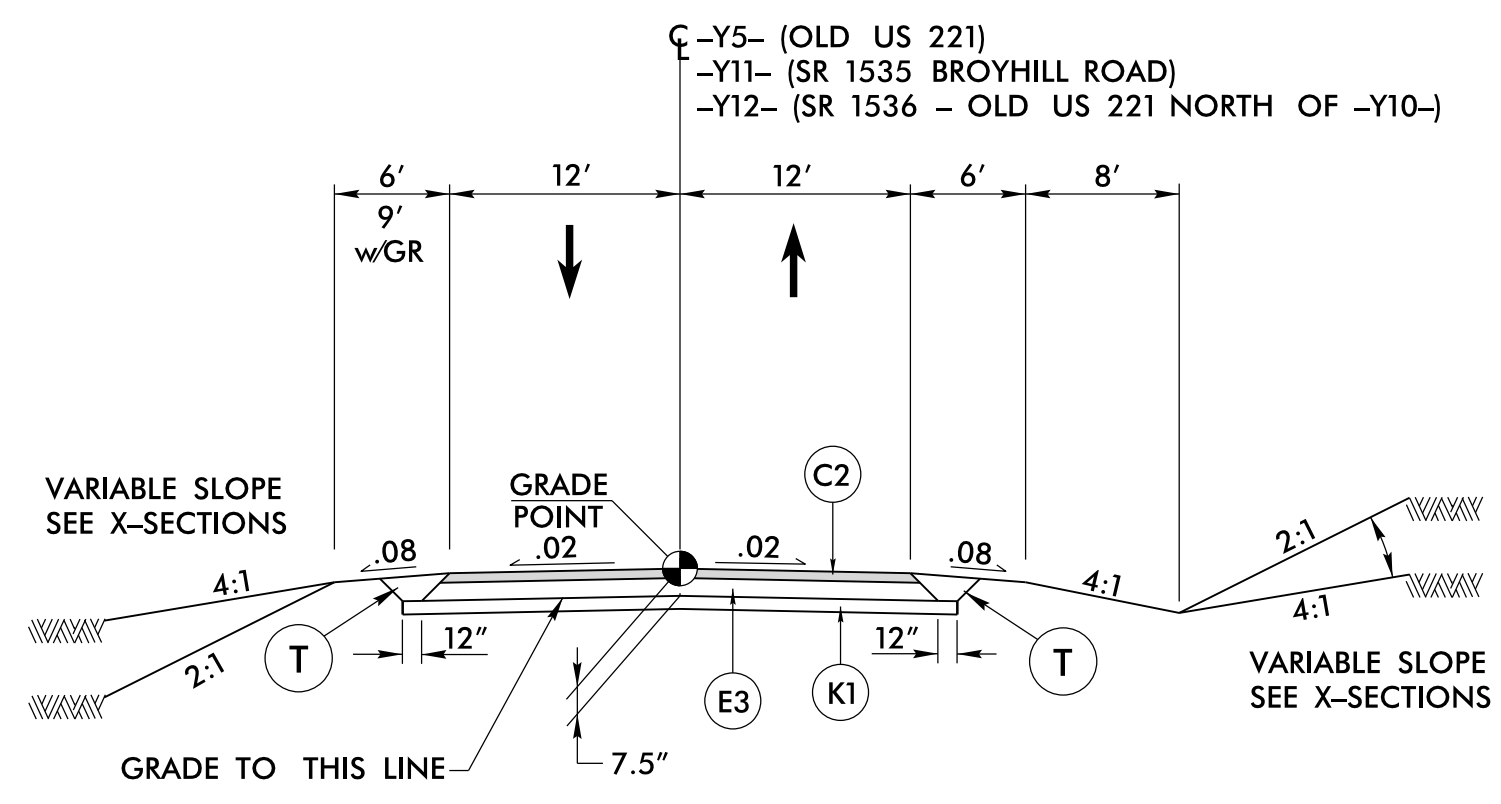

**TYPICAL SECTION NO. 15**  
-Y5- 11+75.00 TO -Y5- 21+01.44  
-Y11- 10+47.29 TO -Y11- 28+00.00  
-Y12- 11+25.00 TO -Y12- 33+00.00

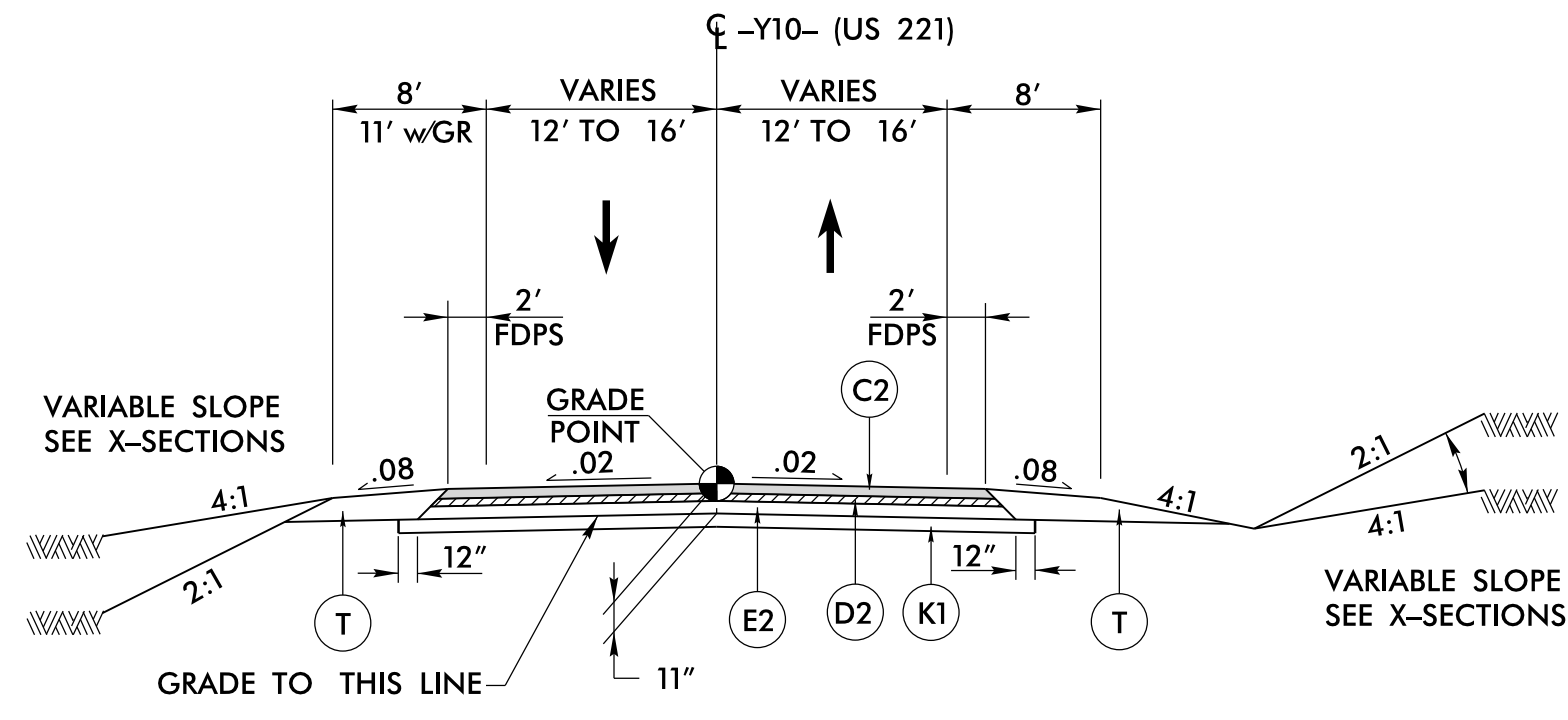

**TYPICAL SECTION NO. 16**  
-Y10- 20+58.96 TO -Y10- 24+81.26 - LEFT  
-Y10- 20+58.96 TO -Y10- 24+81.26 - RIGHT

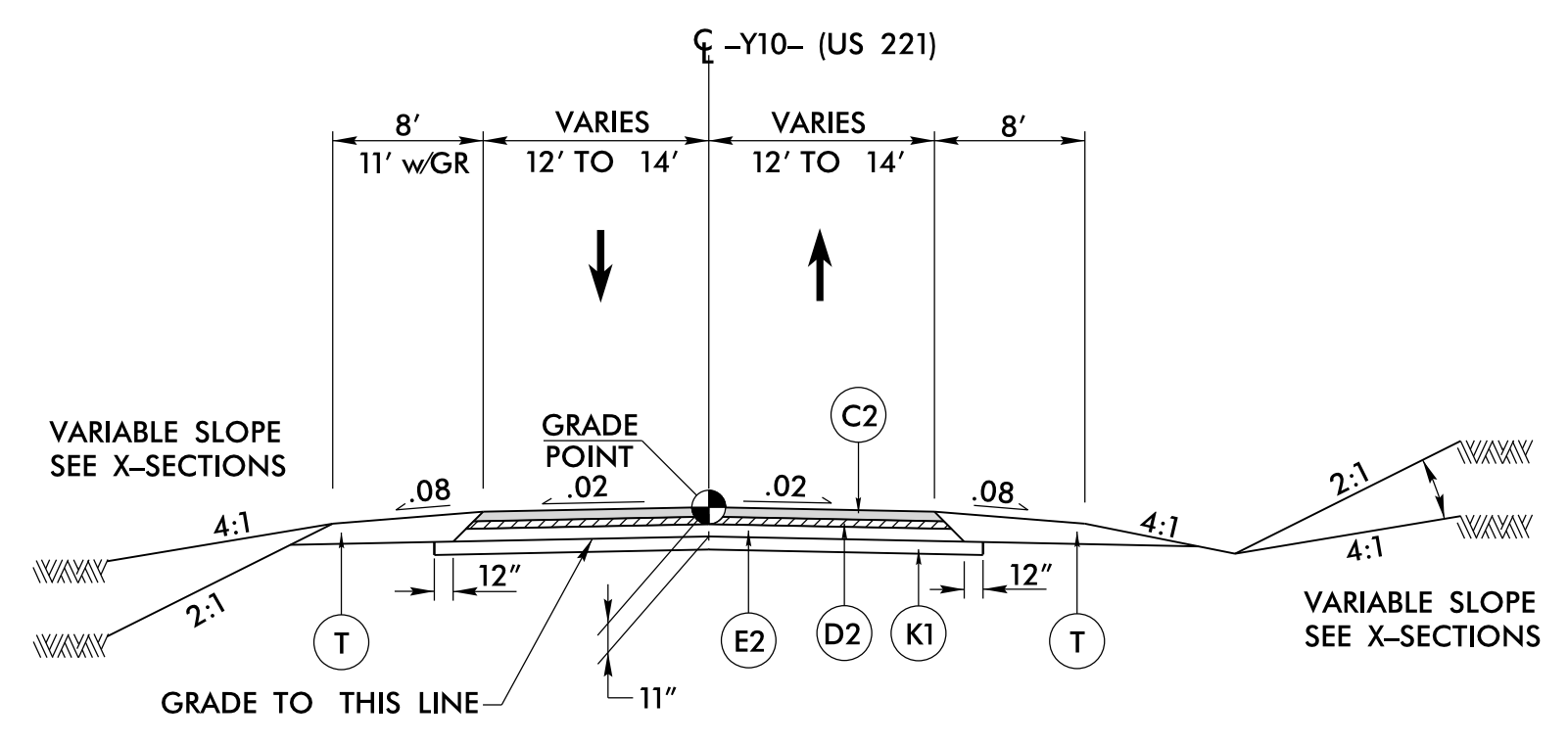

**TYPICAL SECTION NO. 17**  
-Y10- 26+75.30 TO -Y10- 29+70.35 - RIGHT  
-Y10- 26+75.66 TO -Y10- 29+70.35 - LEFT

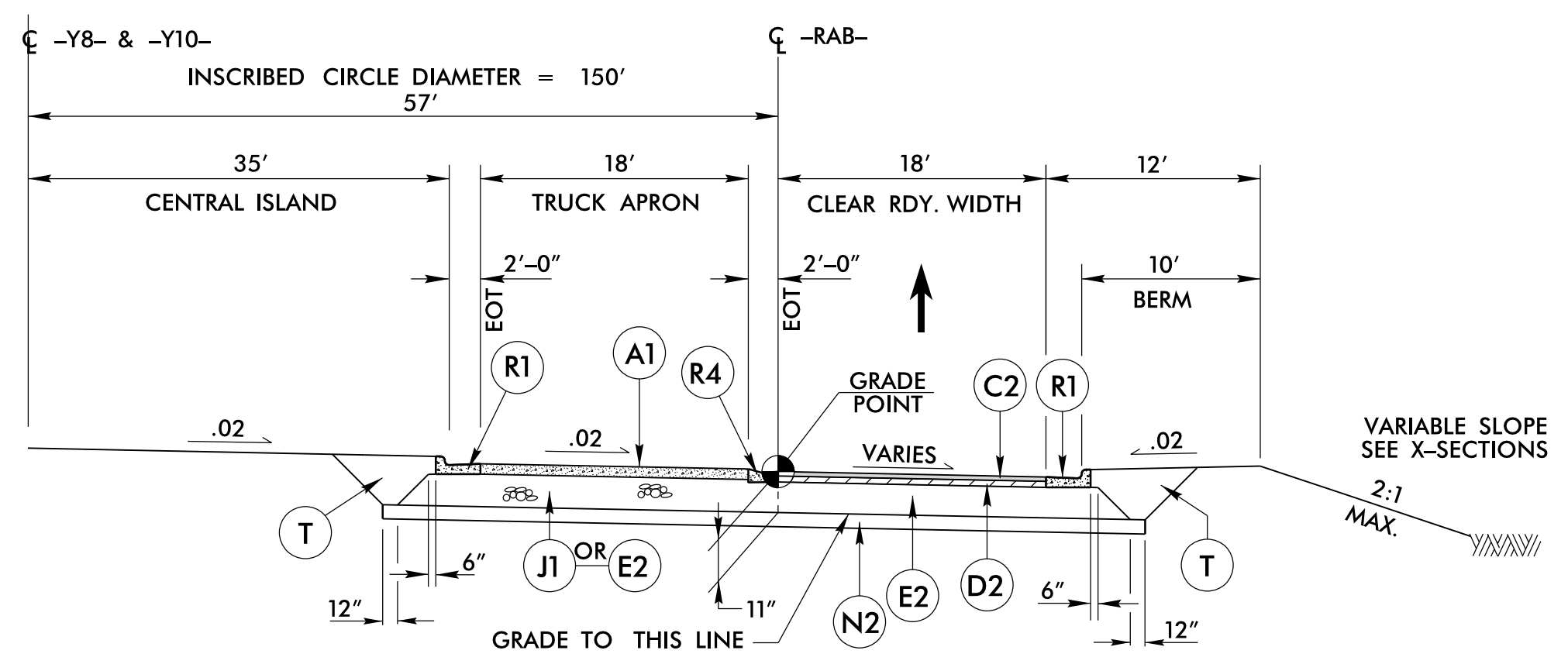

**TYPICAL SECTION NO. 18**  
**ROUNDABOUT -RAB-**  
-RAB- STA 0+00.00 TO -RAB- STA 3+58.14

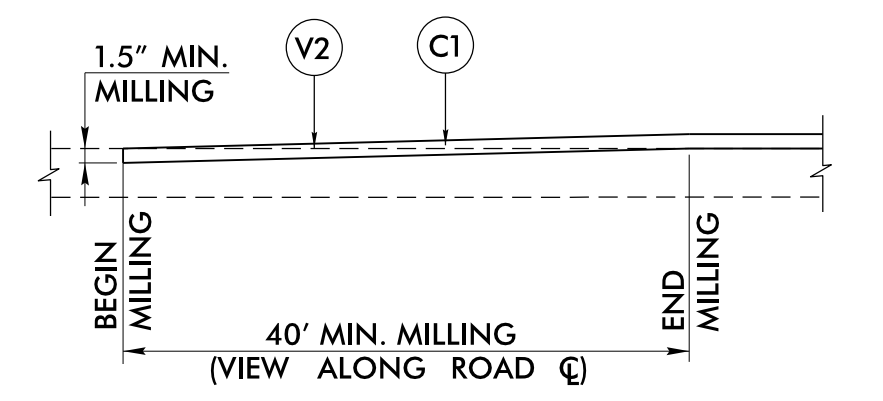

**INCIDENTAL MILLING DETAIL - V2**  
USE IN CONJUNCTION WITH ALL -Y- LINE TIE-INS  
-Y5- 11+75.00 TO -Y5- 12+15.00  
-Y12- 11+25.00 TO -Y12- 11+65.00  
-Y12- 32+60.00 TO -Y12- 33+00.00

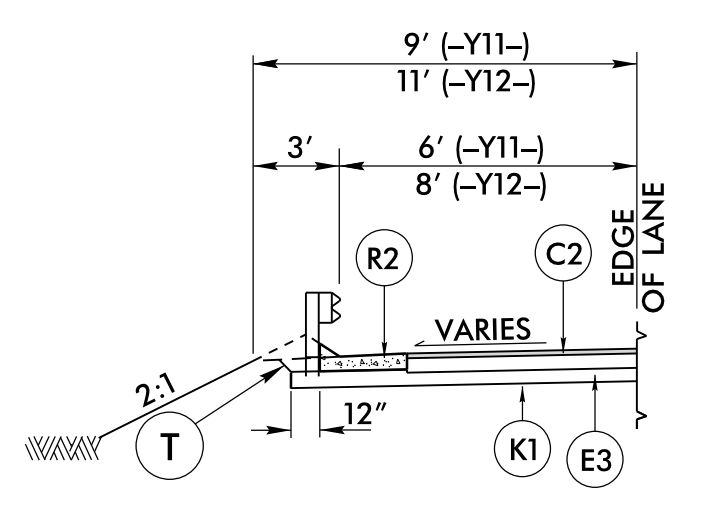

**DETAIL FOR SHOULDER BERM GUTTER**  
USE IN CONJUNCTION WITH TYPICAL SECTION No. 15

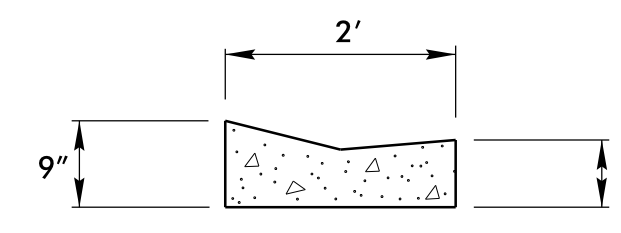

**DETAIL FOR MODIFIED VALLEY GUTTER**  
USE IN CONJUNCTION WITH TYPICAL SECTION No. 18  
FOR ROUNDABOUT TRUCK APRON

REVISIONS  
CONSTRUCTION REV. - APRIL 29, 2022 - Added typical section 13A to include new pavement design for -DR3-

4/29/2022 10:38 AM TYP\_2A-6.DGN



**PAVEMENT SCHEDULE (FINAL)**

PROJECT REFERENCE NO. R-2233BB	SHEET NO. 2A-7
ROADWAY DESIGN ENGINEER 	PAVEMENT DESIGN ENGINEER 
<b>DOCUMENT NOT CONSIDERED FINAL UNLESS ALL SIGNATURES COMPLETED</b>	
<small>2410 WYCLIFF ROAD SUITE 410 RALEIGH, NC 27607 PHONE: 919.881.9959 NC CEA No. F-0928</small> <small>NC DEPARTMENT OF TRANSPORTATION PAVEMENT MANAGEMENT UNIT 1593 MAIL SERVICE CENTER RALEIGH, NC 27699-1393</small>	

ITEM	DESCRIPTION	ITEM	DESCRIPTION	ITEM	DESCRIPTION	ITEM	DESCRIPTION	ITEM	DESCRIPTION	ITEM	DESCRIPTION	ITEM	DESCRIPTION	ITEM	DESCRIPTION				
(A1)	7" CONCRETE	(C4)	3" S9.5C	(D3)	VAR DEPTH I19.0C	(E4)	5" B25.0C	(K1)	CHEMICAL STABILIZATION: 7" SOIL-CEMENT BASE OR 8" LIME-TREATED SOIL	(R1)	2'-6" CONCRETE CURB & GUTTER	(R5)	8"x12" CONCRETE CURB	(U)	EXIST. PAVEMENT				
(C1)	1.5" S9.5B	(C5)	VAR DEPTH S9.5C	(E1)	3" B25.0C	(E5)	VAR DEPTH B25.0C	(K2)	8" CLASS IV SUBGRADE STABILIZATION	(R2)	SHOULDER BERM GUTTER	(R6)	CONCRETE EXPRESSWAY GUTTER	(Z)	MILLED RUMBLE STRIP				
(C2)	3" S9.5B	(D1)	2.5" I19.0C	(E2)	4" B25.0C	(J1)	6" ABC	(N1)	GEOTEXTILE FOR SOIL STABILIZATION	(R3)	5" CONC. ISLAND	(S)	4" CONC. SIDEWALK	(V1)	(V2)	(V3)	(V4)	PAVEMENT MILLING	
(C3)	VAR DEPTH S9.5B	(D2)	4" I19.0C	(E3)	4.5" B25.0C	(J2)	8" ABC	(N2)	GEOTEXTILE FOR PAVEMENT STABILIZATION	(P)	PRIME COAT	(R4)	2' MODIFIED VALLEY GUTTER	(T)	EARTH	(W1)	(W2)	(W3)	VARIABLE DEPTH PAVEMENT WEDGING

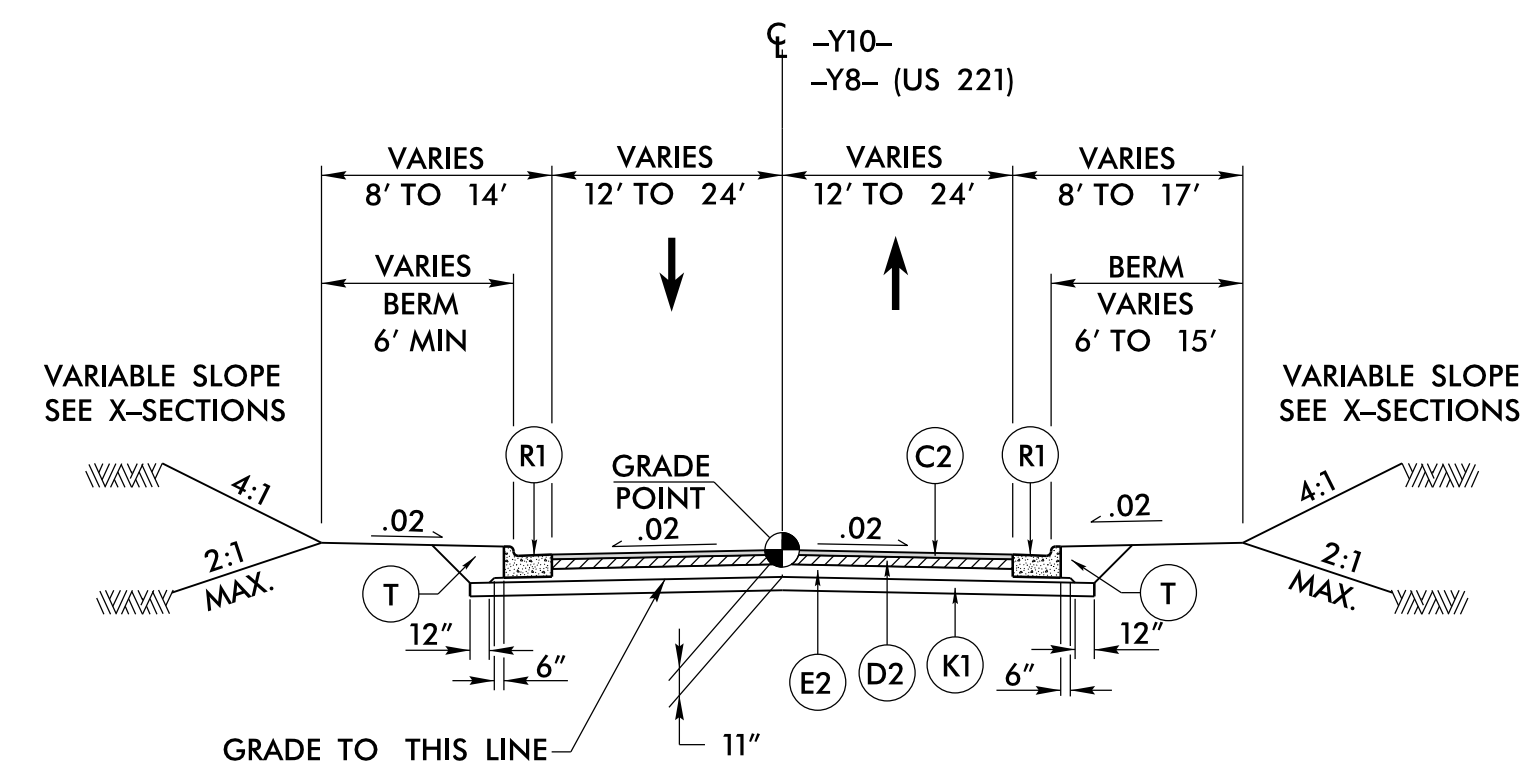

**TYPICAL SECTION NO. 19**  
 -Y8- 15+00.00 TO -Y8- 20+57.13  
 -Y10- 18+30.59 TO -Y10- 20+58.16

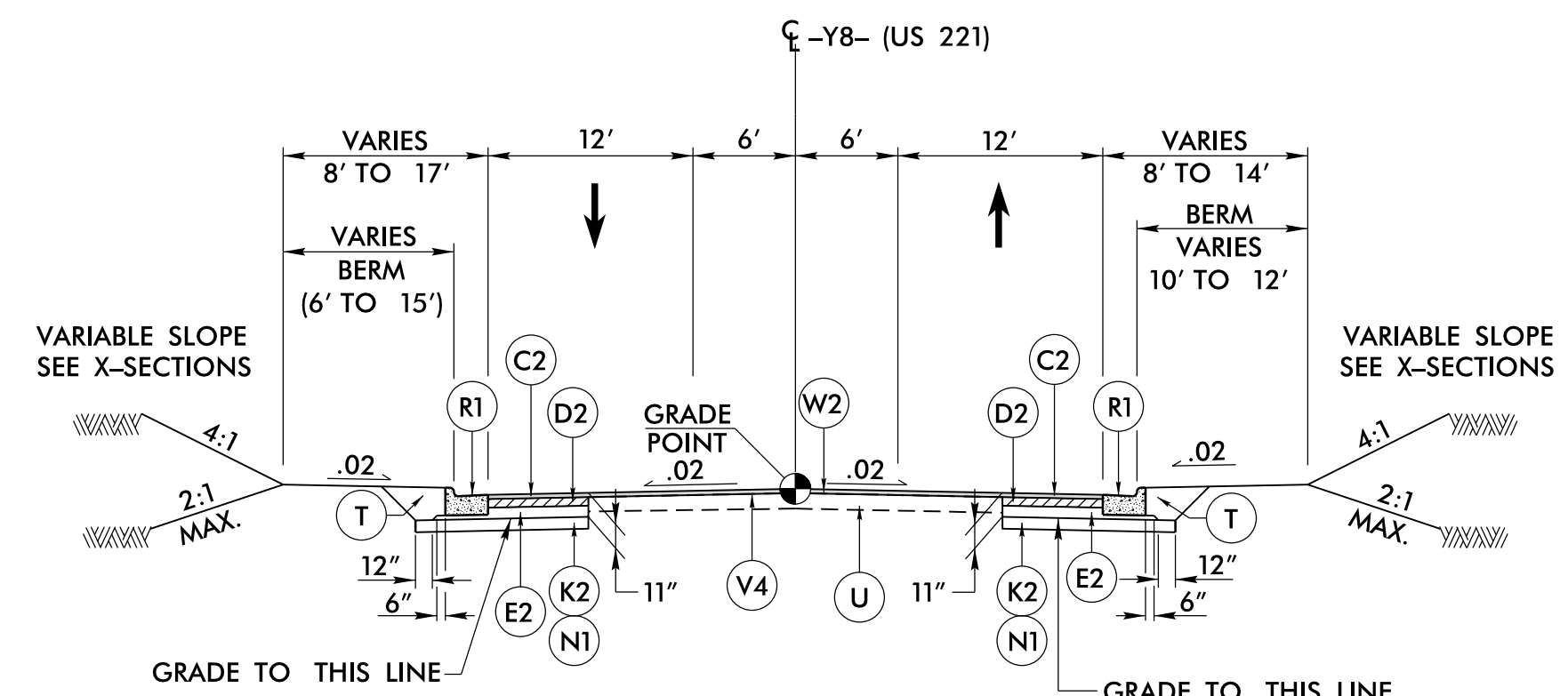

**TYPICAL SECTION NO. 19A**  
 -Y8- 22+07.13 TO -Y8- 36+60.00

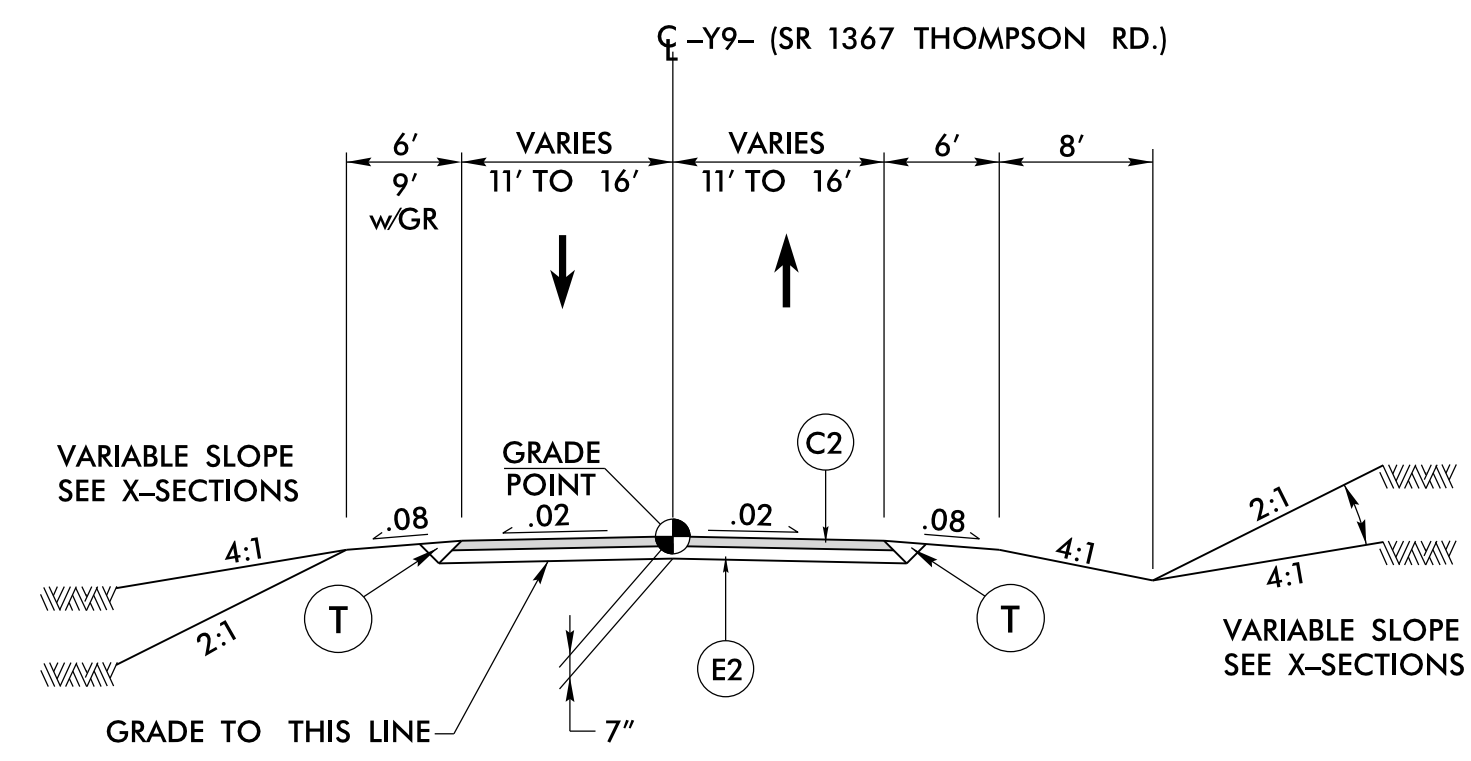

**TYPICAL SECTION NO. 20**  
 -Y9- 13+50.00 TO -Y9- 16+53.96

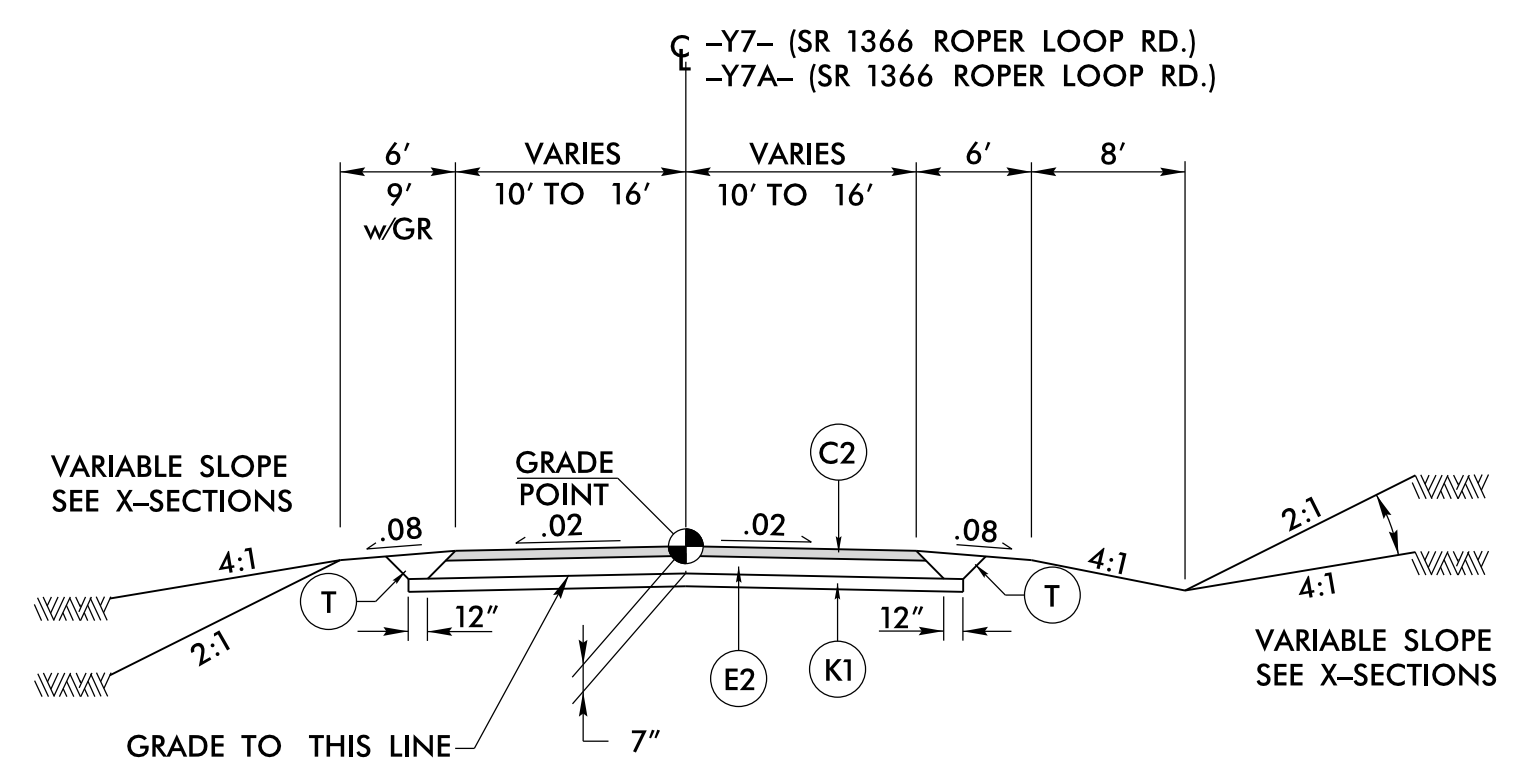

**TYPICAL SECTION NO. 21**  
 -Y7- 14+75.00 TO -Y7- 23+08.78  
 -Y7A- 13+75.00 TO -Y7A- 17+98.84

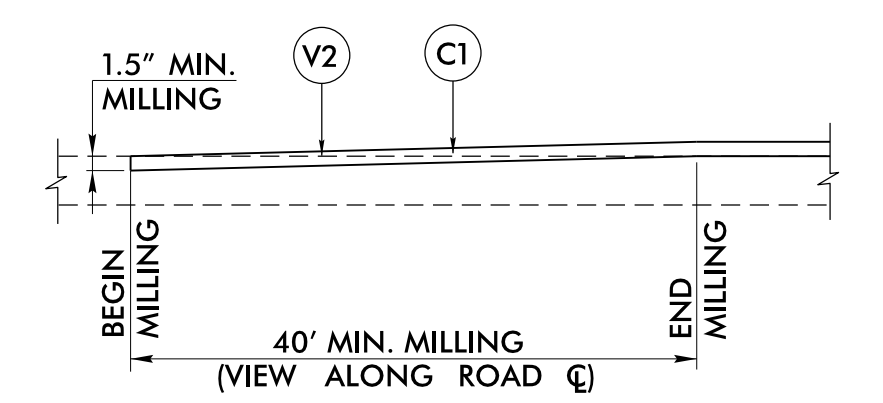

**INCIDENTAL MILLING DETAIL - V2**  
 USE IN CONJUNCTION WITH ALL -Y- LINE TIE-INS  
 -Y7- 14+75.00 TO -Y7- 15+15.00  
 -Y7A- 13+75.00 TO -Y7A- 14+15.00  
 -Y8- 15+00.00 TO -Y8- 15+40.00  
 -Y8- 36+20.00 TO -Y8- 36+60.00  
 -Y9- 13+50.00 TO -Y9- 13+90.00  
 -Y25EXT- 13+00.00 TO -Y25EXT- 13+55.00

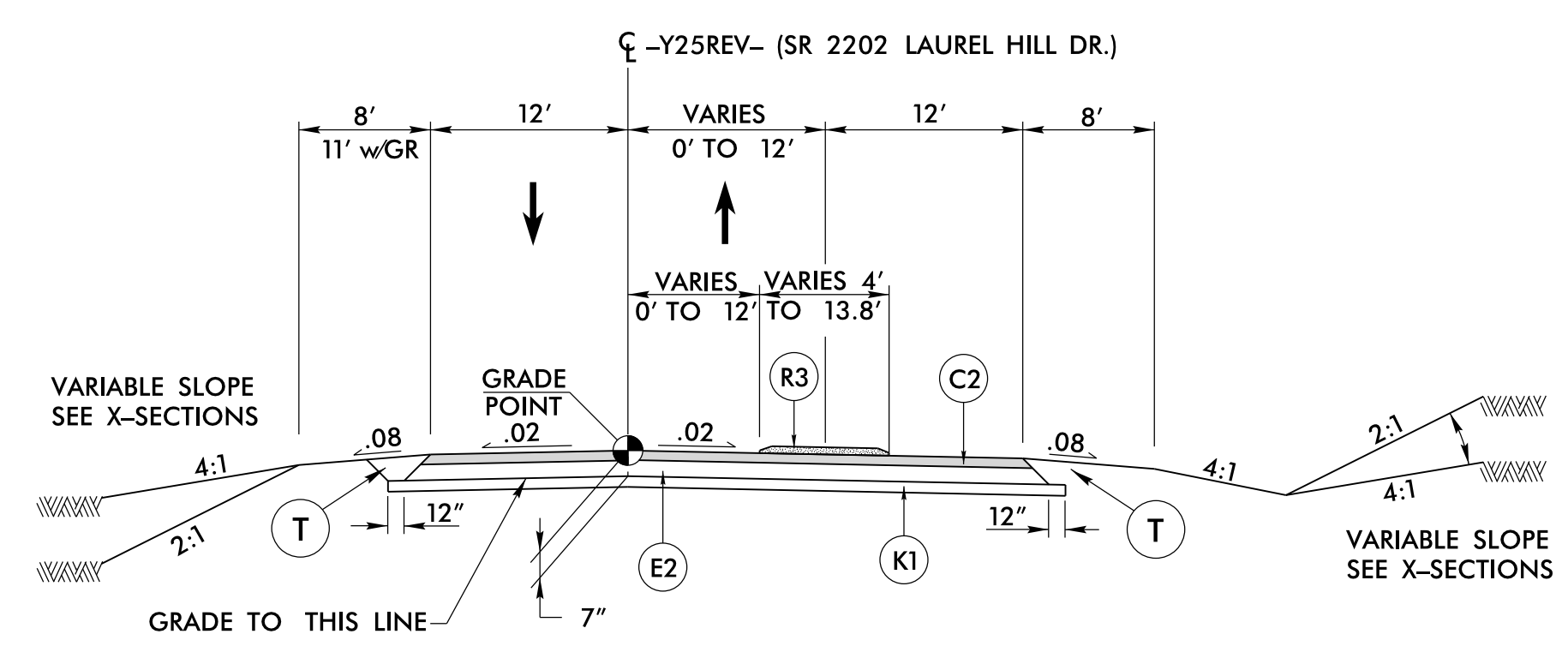

**TYPICAL SECTION NO. 22**  
 -Y25REV- 17+50.00 TO -Y25REV- 33+28.28

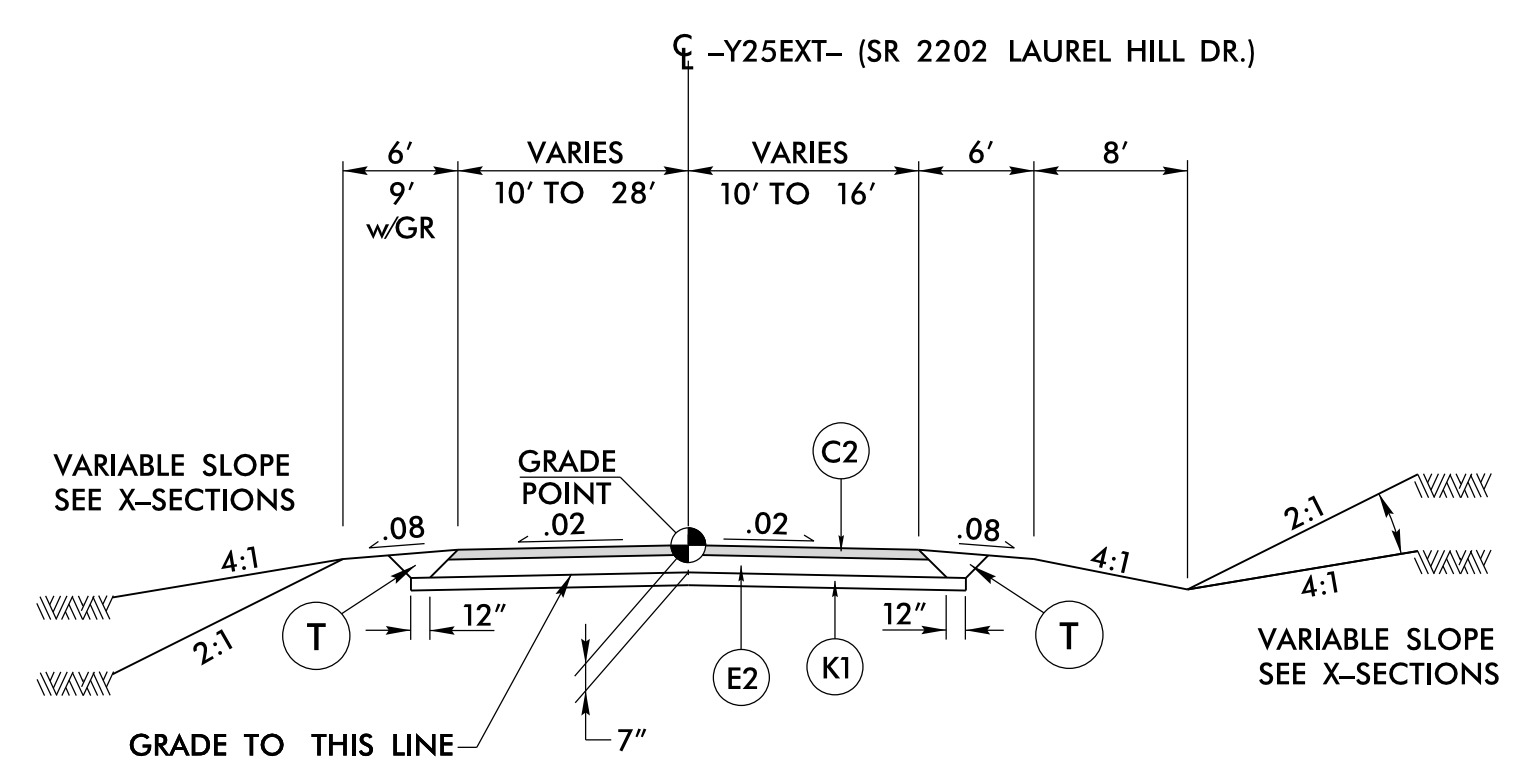

**TYPICAL SECTION NO. 23**  
 -Y25EXT- 10+12.00 TO -Y25EXT- 13+00.00

8/10/2021 3:25:56 PM  
 R-2233BB\_PAV\_TYP\_2A-7.DGN  
 11:58:56 AM



PAVEMENT SCHEDULE (FINAL)

ITEM	DESCRIPTION	ITEM	DESCRIPTION	ITEM	DESCRIPTION	ITEM	DESCRIPTION	ITEM	DESCRIPTION	ITEM	DESCRIPTION	ITEM	DESCRIPTION	ITEM	DESCRIPTION
(A1)	7" CONCRETE	(C4)	3" S9.5C	(D3)	VAR DEPTH I19.0C	(E4)	5" B25.0C	(K1)	CHEMICAL STABILIZATION: 7" SOIL-CEMENT BASE OR 8" LIME-TREATED SOIL	(R1)	2'-6" CONCRETE CURB & GUTTER	(R5)	8"x12" CONCRETE CURB	(U)	EXIST. PAVEMENT
(C1)	1.5" S9.5B	(C5)	VAR DEPTH S9.5C	(E1)	3" B25.0C	(E5)	VAR DEPTH B25.0C	(K2)	8" CLASS IV SUBGRADE STABILIZATION	(R2)	SHOULDER BERM GUTTER	(R6)	CONCRETE EXPRESSWAY GUTTER	(Z)	MILLED RUMBLE STRIP
(C2)	3" S9.5B	(D1)	2.5" I19.0C	(E2)	4" B25.0C	(J1)	6" ABC	(N1)	GEOTEXTILE FOR SOIL STABILIZATION	(R3)	5" CONC. ISLAND	(S)	4" CONC. SIDEWALK	(V1) (V2) (V3) (V4)	PAVEMENT MILLING
(C3)	VAR DEPTH S9.5B	(D2)	4" I19.0C	(E3)	4.5" B25.0C	(J2)	8" ABC	(N2)	GEOTEXTILE FOR PAVEMENT STABILIZATION	(P)	PRIME COAT	(R4)	2' MODIFIED VALLEY GUTTER	(T)	EARTH
														(W1) (W2) (W3)	VARIABLE DEPTH PAVEMENT WEDGING

PROJECT REFERENCE NO. R-2233BB SHEET NO. 2A-8

ROADWAY DESIGN ENGINEER DENNIS J. MORY  
NOT A CERTIFIED DOCUMENT AS TO THE ORIGINAL DOCUMENT BUT ONLY AS TO THE REVISIONS.  
THIS DOCUMENT ORIGINALLY ISSUED AND SEALED BY:  
DENNIS J. MORY  
PE# 020031 ON 8/25/2021  
THIS DOCUMENT IS ONLY CERTIFIED AS TO THE REVISIONS.

PAVEMENT DESIGN ENGINEER  
SEAL 024964

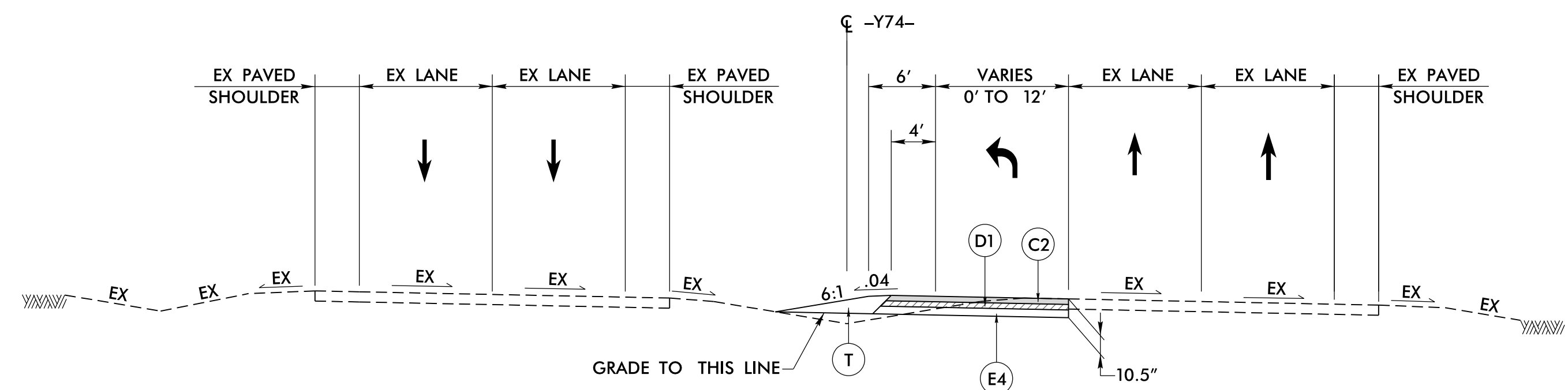

TYPICAL SECTION NO. 24  
-Y74- 10+00.00 TO -Y74- 17+89.51

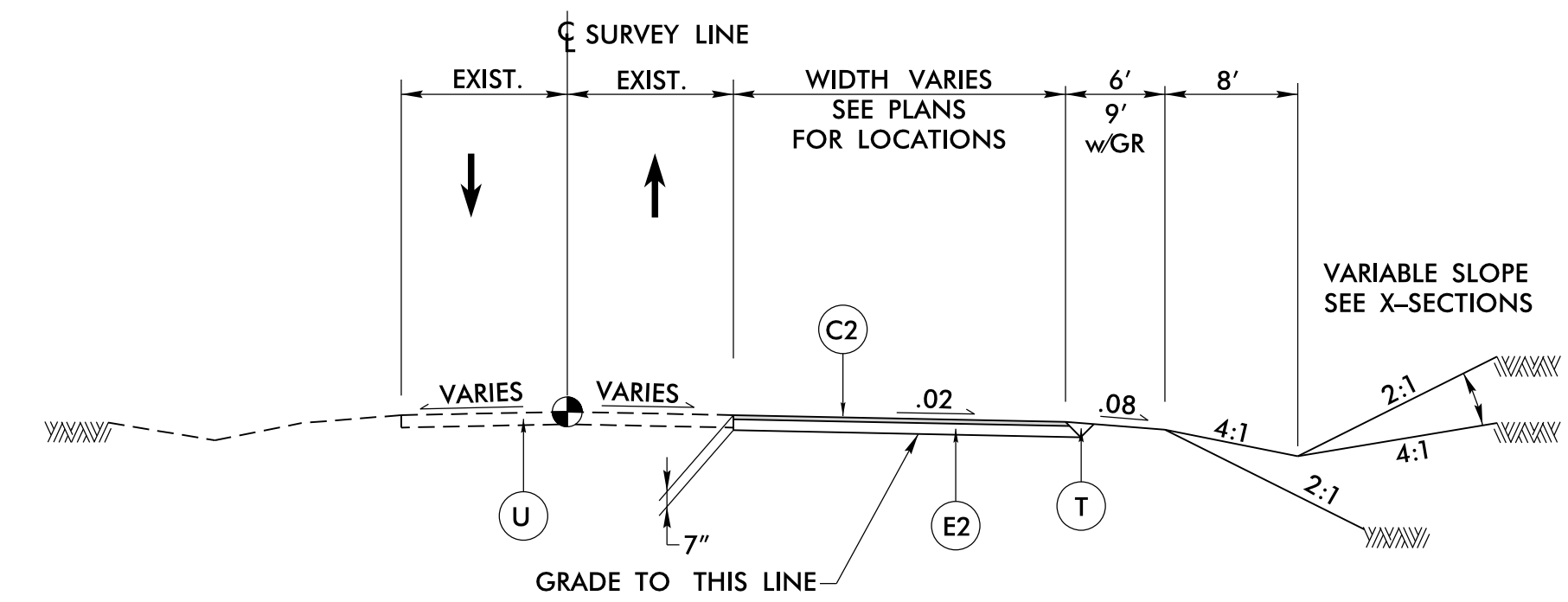

TYPICAL SECTION NO. 25  
CUL-DE-SACS & STREET CONNECTIONS

CUL-DE-SACS			
LABEL	STREET	CENTER	PAVING LIMITS
-CUL1-	LAUREL HILL RD.	-Y25- 15 + 70.10 (20.25' RT.)	-Y25- 15 + 00.65
-CUL2-	LAUREL HILL RD.	-DR2- 10 + 34.38 (23.69' RT.)	-Y25- 25 + 16.69
-CUL3-	EAST 2ND ST.	-Y16- 13 + 03.91 (20.92' LT.)	-Y16- 12 + 32.17
-CUL4-	EAST 2ND ST.	-Y16- 17 + 82.39 (19.25' RT.)	-Y16- 18 + 55.84
-CUL5-	COLLETT ST.	-Y17- 13 + 21.98 (20.16' RT.)	-Y17- 12 + 52.47
-CUL6-	COLLETT ST.	-Y17- 17 + 78.13 (17.44' LT)	-Y17- 18 + 50.00
-CUL7-	REESE ST.	-Y20- 11 + 92.83 (20.91' LT.)	-Y20- 11 + 23.32
-CUL8-	SOUTHERN ST.	-Y21- 17 + 36.58 (22.04' RT.)	-Y21- 16 + 64.63
-CUL9-	LONG ST.	-Y23- 25 + 93.98 (22.00' RT.)	-Y23- 26 + 64.82
-CUL10-	ROCK RD.	-Y22A- 34 + 80.00 (19.00' LT.)	-Y22A- 39 + 96.06
-CUL13-	GILBOA CHURCH RD.	-Y42- 14 + 45.32 (21.36' RT.)	-Y42- 15 + 46.08
-CUL14-	SOUTHERN ST.	-L3- 839 + 94.99 (150.79' RT.)	-L3- 840 + 01.33 (211.66' RT)
-CUL11-	OLD US 221	-Y12- 41 + 97.56 (21.19' LT)	-Y12- 41 + 28.01
-CUL15-	LONG ST.	-Y23A- 45 + 53.87 (21.00' RT.)	-Y23A- 46 + 28.28
-CUL16-	OLD CHARLOTTE RD.	-L3- 779 + 79.91 (226.59' LT.)	-L3- 779 + 38.74 (289.42' LT.)

STREET CONNECTIONS		
LABEL	DESCRIPTION	LOCATION
-STCON1-	OAK ST. TO REECE ST.	-Y20- 13 + 72.71 TO -Y20- 16 + 56.66
-STCON2-	HILDERBRAND DR. TO HUDGEN'S LAKE DR.	-L3- 871 + 07.28 (131.42' LT.) TO -L3- 871 + 55.28 (147.40' LT.)
-STCON3-	SASAFFRAS DR. TO RIDGELAND DR.	-L3- 896 + 53.63 (129.30' LT.) TO -L3- 896 + 89.24 (185.15' LT.)
-STCON4-	CHURCH ST. TO SANDY WOODS LN.	-Y23- 21 + 23.17 TO -Y23- 21 + 52.30 (43.68' RT.)
-STCON5-	US 221 TO GOLD HILL MISSIONARY BAPTIST CHURCH	-L3- 941 + 22.37 (127.71' LT.) TO -L3- 944 + 44.60 (129.15' LT.)

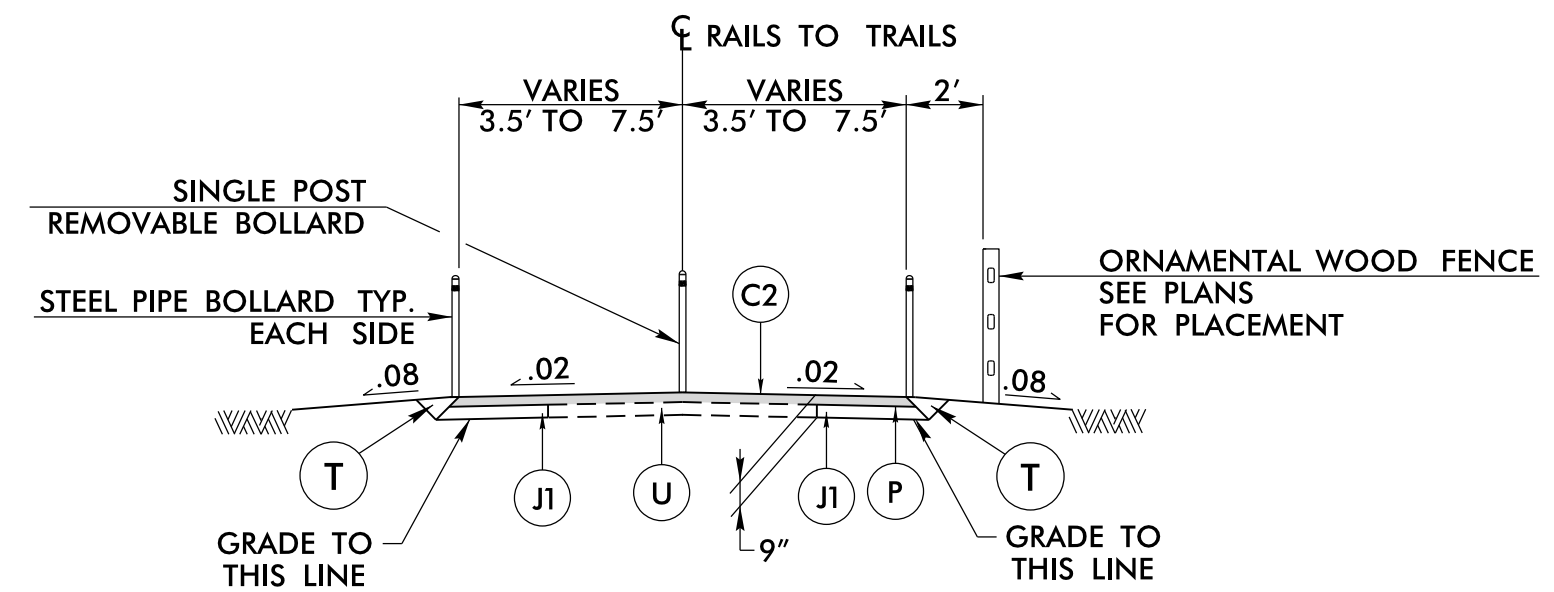

RAILS TO TRAILS PAVEMENT CONNECTIONS

LOCATION	DESCRIPTION	PAVING LENGTH	BOLLARD LOCATIONS
-Y6- 14+11 LT.	EXISTING TRAIL IS 7' GRAVEL	LENGTH = 30'	PLACE 38' LT.
-Y6- 14+48 RT.	EXISTING TRAIL IS 7' GRAVEL	LENGTH = 24'	PLACE 32' RT.
-Y11- 14+82 RT.	EXISTING TRAIL IS 12' PAVED	LENGTH = 21'	PLACE 35' RT.
-Y11- 14+82 LT.	EXISTING TRAIL IS 12' PAVED	LENGTH = 21'	PLACE 35' LT.
-TR1-	EXISTING TRAIL IS 12' PAVED	LENGTH = 247'	SEE SHEET 11
-TR2-	EXISTING TRAIL IS 7' GRAVEL	LENGTH = 142'	SEE SHEET 11

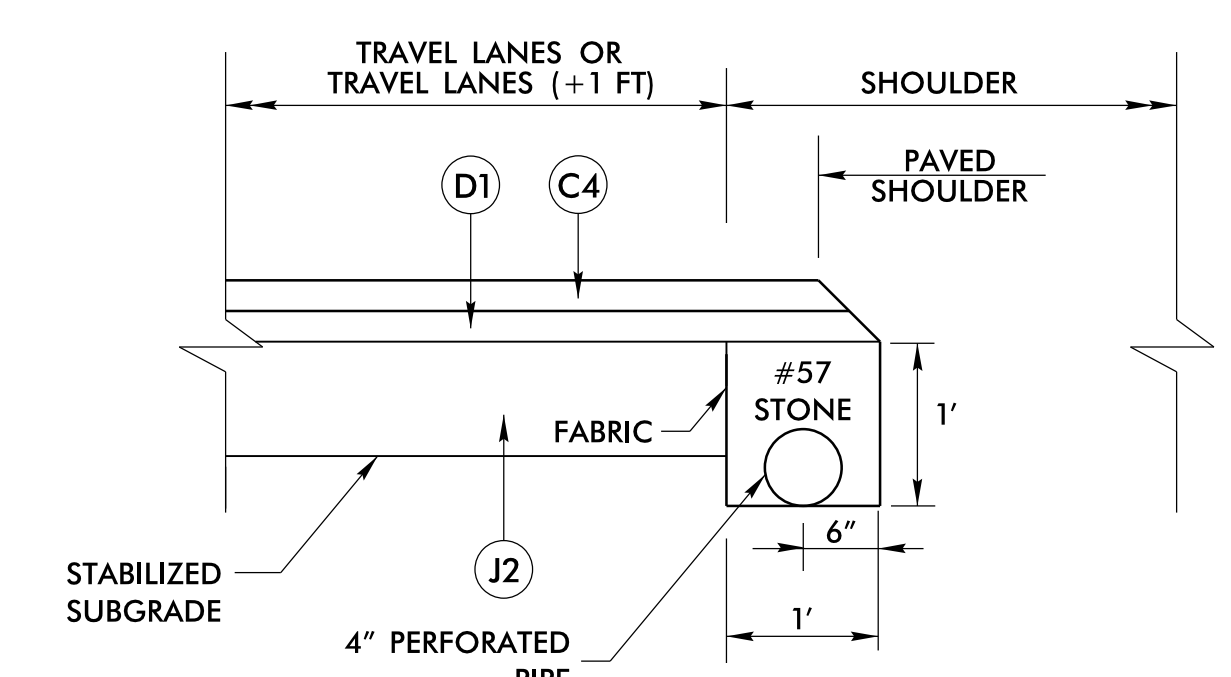

SHOULDER DRAIN DETAIL WITH ABC  
NOT TO SCALE

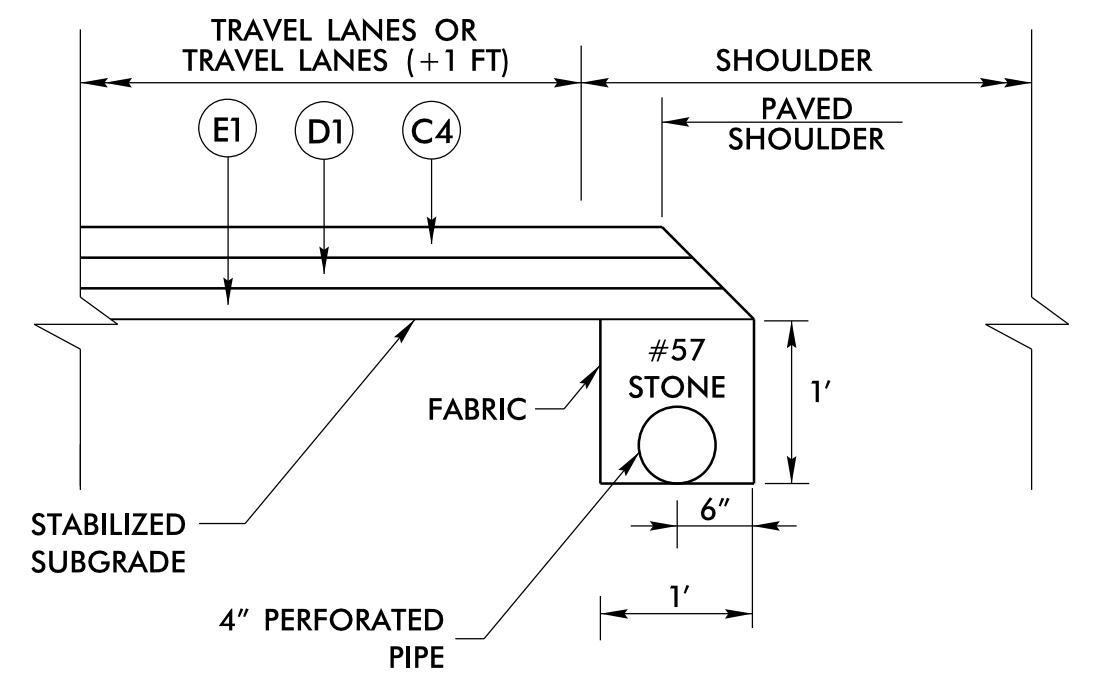

SHOULDER DRAIN DETAIL B25.0C  
NOT TO SCALE

NOTE: SEE SHEET 3B-4 FOR STATION LOCATIONS AND QUANTITY SUMMARY.

DOCUMENT NOT CONSIDERED FINAL UNLESS ALL SIGNATURES COMPLETED

**Dewberry**  
2510 WYCLIFF ROAD  
RALEIGH, NC 27607  
PHONE: 919 881 9739  
NC REG. NO. F08229

NC DEPARTMENT OF TRANSPORTATION  
PAVEMENT MANAGEMENT UNIT  
1593 MAIL SERVICE CENTER  
RALEIGH, NC 27699-1593

ROADWAY DESIGN ENGINEER  
SEAL 038648  
DENNIS J. MORY  
PE# 020031

REVISIONS  
CONSTRUCTION REV. - APRIL 29, 2022 - Revised Rails to Trails typical to include wider widths and ornamental wood fence

6/2/2022

Inv. valid exp. professional seal 024964  
DENNIS J. MORY, P.E., R-2233BB, RDY-TYP-2A-8.DGN



PAVEMENT SCHEDULE (FINAL)

ITEM	DESCRIPTION	ITEM	DESCRIPTION	ITEM	DESCRIPTION	ITEM	DESCRIPTION	ITEM	DESCRIPTION	ITEM	DESCRIPTION	ITEM	DESCRIPTION	ITEM	DESCRIPTION				
(A1)	7" CONCRETE	(C4)	3" S9.5C	(D3)	VAR DEPTH I19.0C	(E4)	5" B25.0C	(K1)	CHEMICAL STABILIZATION: 7" SOIL-CEMENT BASE OR 8" LIME-TREATED SOIL	(R1)	2'-6" CONCRETE CURB & GUTTER	(R5)	8"x12" CONCRETE CURB	(U)	EXIST. PAVEMENT				
(C1)	1.5" S9.5B	(C5)	VAR DEPTH S9.5C	(E1)	3" B25.0C	(E5)	VAR DEPTH B25.0C	(K2)	8" CLASS IV SUBGRADE STABILIZATION	(R2)	SHOULDER BERM GUTTER	(R6)	CONCRETE EXPRESSWAY GUTTER	(Z)	MILLED RUMBLE STRIP				
(C2)	3" S9.5B	(D1)	2.5" I19.0C	(E2)	4" B25.0C	(J1)	6" ABC	(N1)	GEOTEXTILE FOR SOIL STABILIZATION	(R3)	5" CONC. ISLAND	(S)	4" CONC. SIDEWALK	(V1)	(V2)	(V3)	(V4)	PAVEMENT MILLING	
(C3)	VAR DEPTH S9.5B	(D2)	4" I19.0C	(E3)	4.5" B25.0C	(J2)	8" ABC	(N2)	GEOTEXTILE FOR PAVEMENT STABILIZATION	(P)	PRIME COAT	(R4)	2' MODIFIED VALLEY GUTTER	(T)	EARTH	(W1)	(W2)	(W3)	VARIABLE DEPTH PAVEMENT WEDGING

PROJECT REFERENCE NO. R-2233BB	SHEET NO. 2A-9
ROADWAY DESIGN ENGINEER 	PAVEMENT DESIGN ENGINEER 
DOCUMENT NOT CONSIDERED FINAL UNLESS ALL SIGNATURES COMPLETED	
2410 WYCLIFF ROAD RALEIGH, NC 27607 PHONE: 919 881-9959 NC CCA No. F-0628	
NC DEPARTMENT OF TRANSPORTATION PAVEMENT MANAGEMENT UNIT 1593 MAIL SERVICE CENTER RALEIGH, NC 27699-1593	

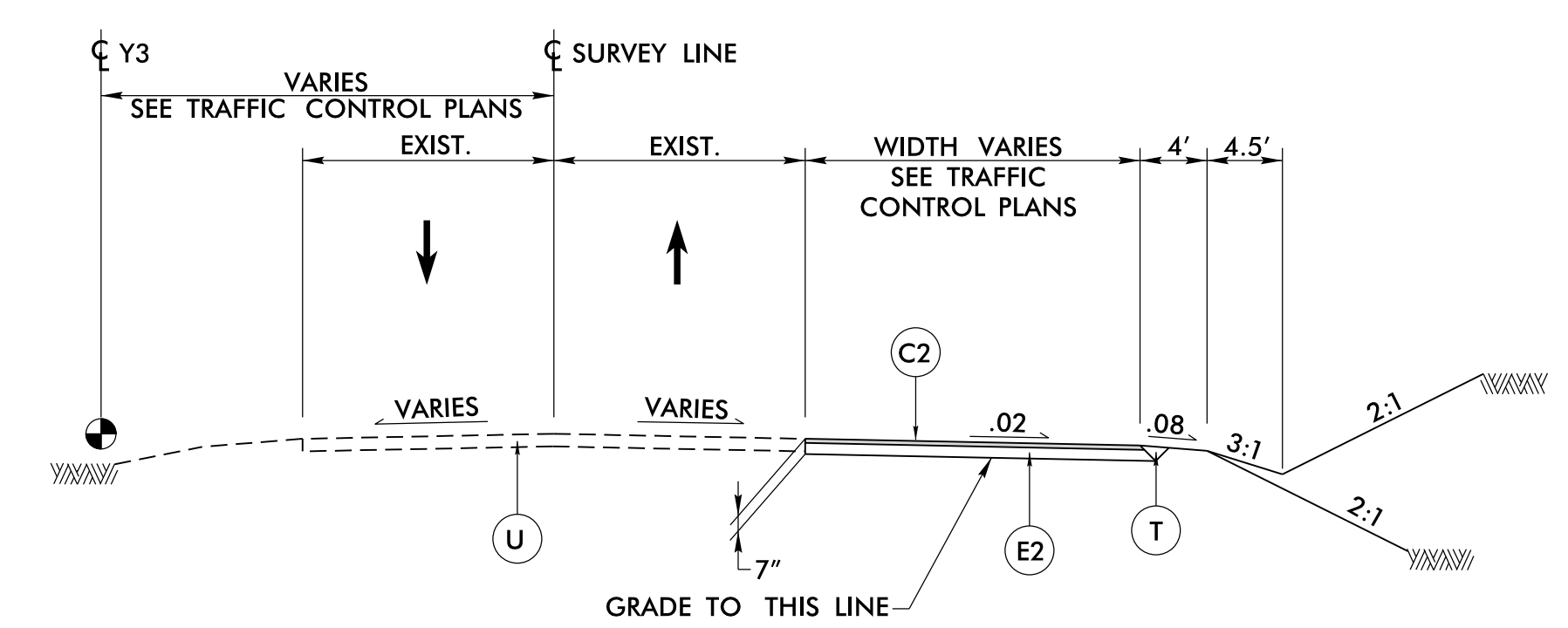

**TYPICAL SECTION NO. 26**

TEMPORARY PAVEMENT FROM  
-Y3- 13+75.00 TO 23+00.00 RT

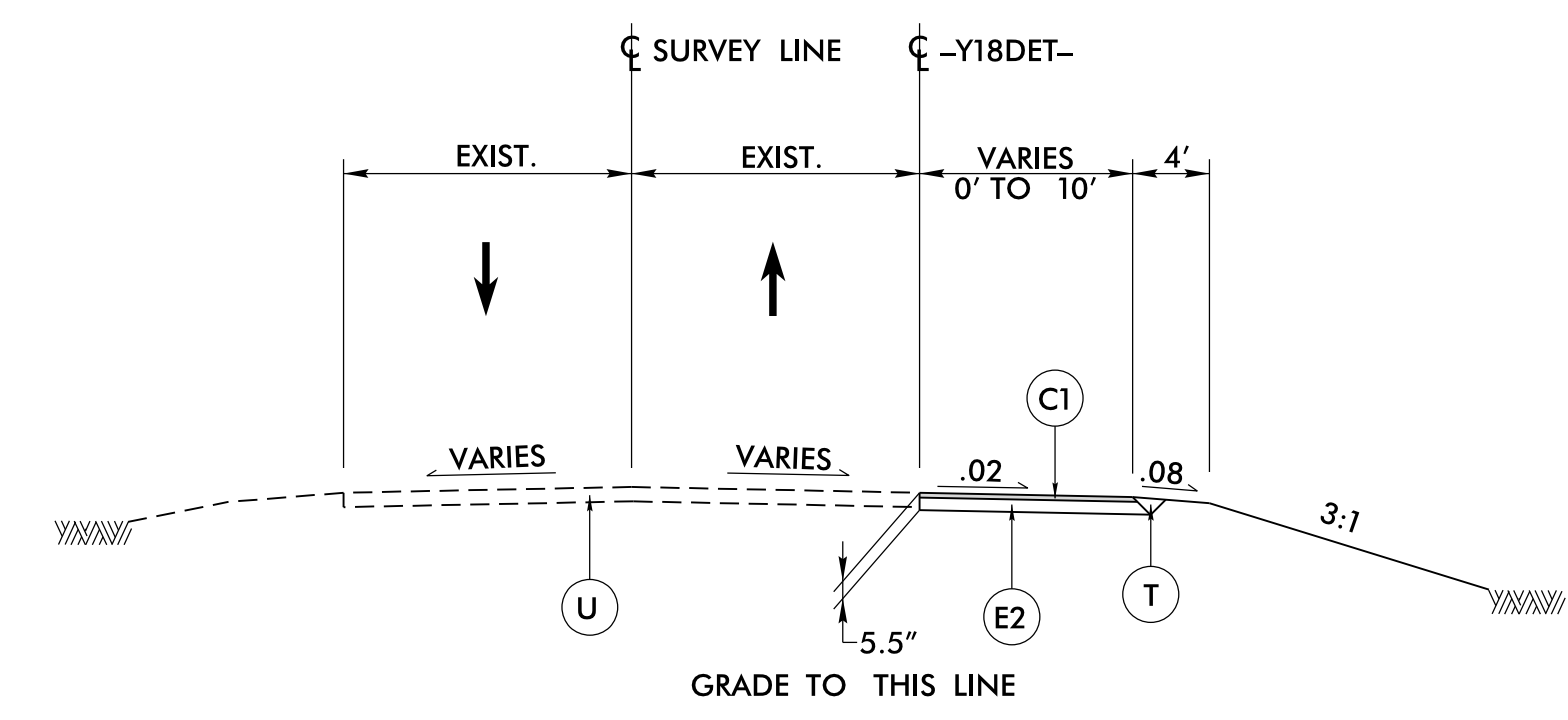

**TYPICAL SECTION NO. 28**

TEMPORARY PAVEMENT FROM  
-Y18DET- 10+00.00 TO 10.76.97

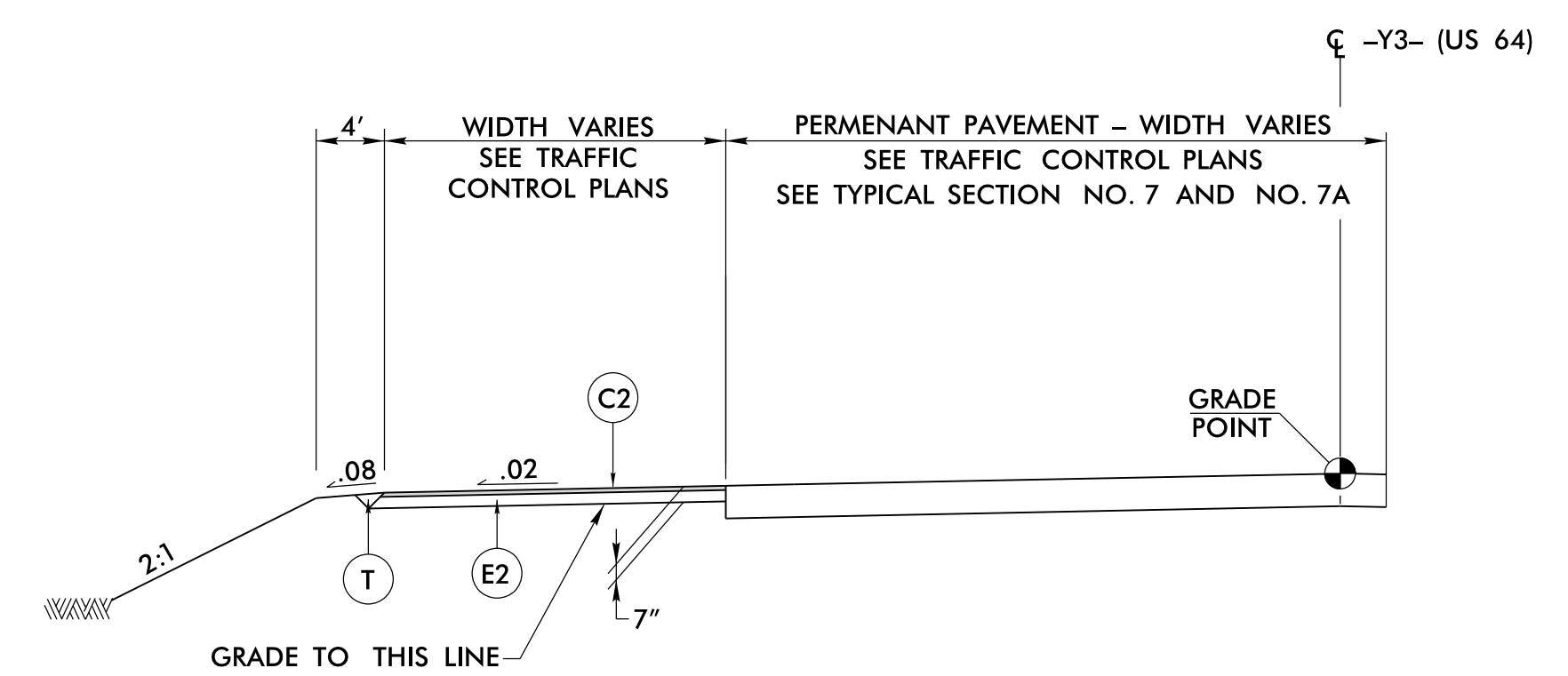

**TYPICAL SECTION NO. 27**

TEMPORARY PAVEMENT FROM  
-Y3- 12+50.00 TO 19+50.00

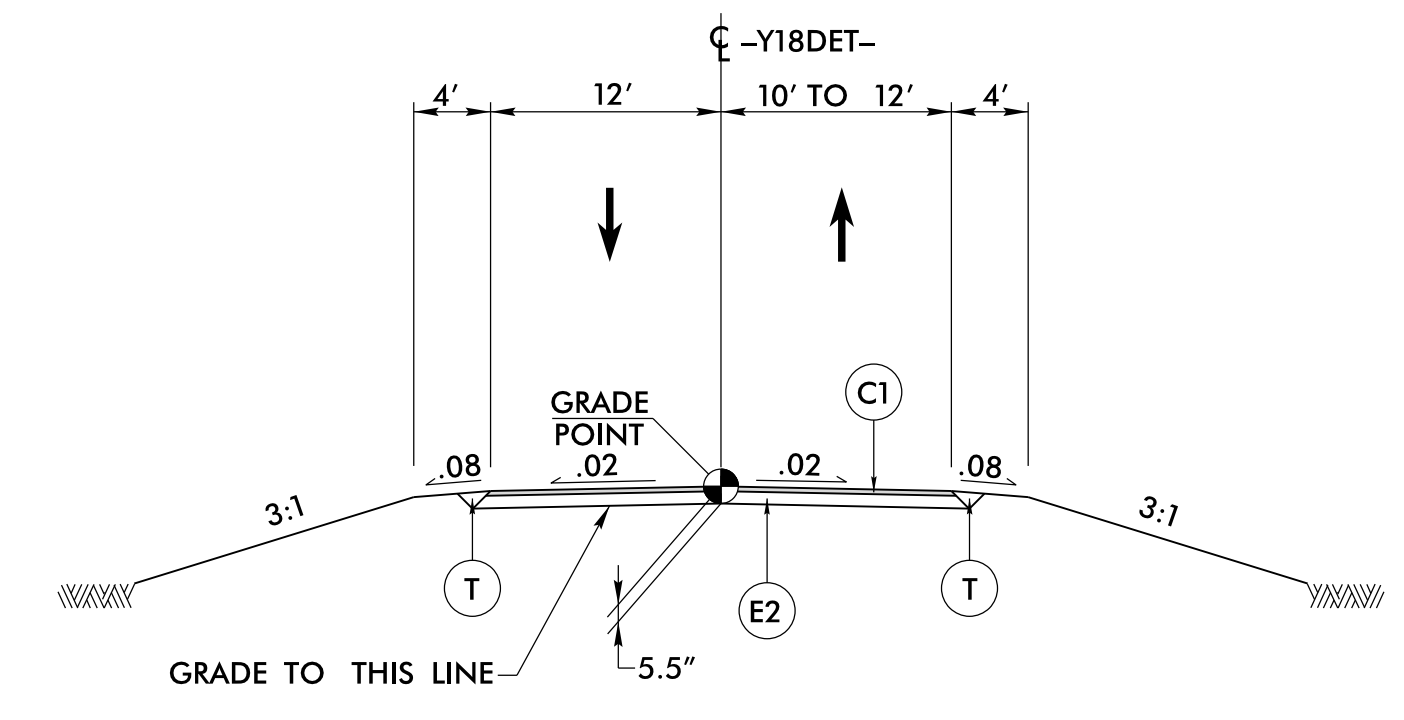

**TYPICAL SECTION NO. 29**

TEMPORARY PAVEMENT FROM  
-Y18DET- 10+76.97 TO 13+80.03

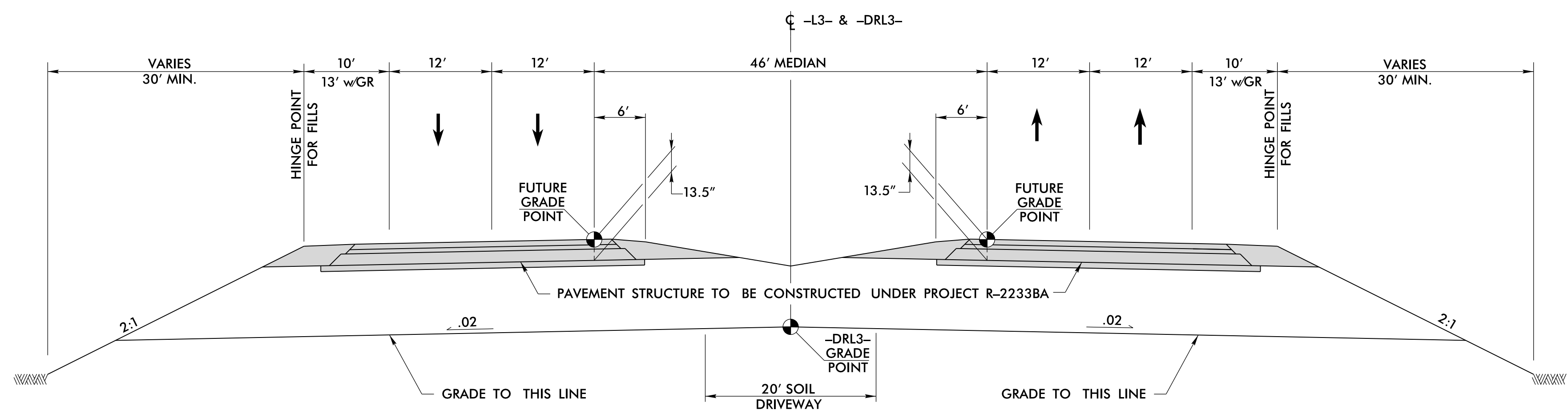

**TYPICAL SECTION NO. 30**

**SOUTHBOUND LANES**  
-L3- 733+30.00 TO -L3- 743+21.39

**NORTHBOUND LANES**  
-L3- 733+30.00 TO -L3- 743+21.39

6/2/2019

8/10/2019 3:28:10 PM  
R-2233BBE\_R0Y\_TYP\_2A-9.DGN



5/14/20

20

25



2610 WYCLIFF ROAD  
SUITE 410  
RALEIGH, NC 27607  
PHONE: 919.881.9999  
NC COA No. F-09251

PROJECT REFERENCE NO. R-2233BB	SHEET NO. 2B-1
RW SHEET NO.	
ROADWAY DESIGN ENGINEER	HYDRAULICS ENGINEER
	
6/15/2021	
<b>DOCUMENT NOT CONSIDERED FINAL UNLESS ALL SIGNATURES COMPLETED</b>	

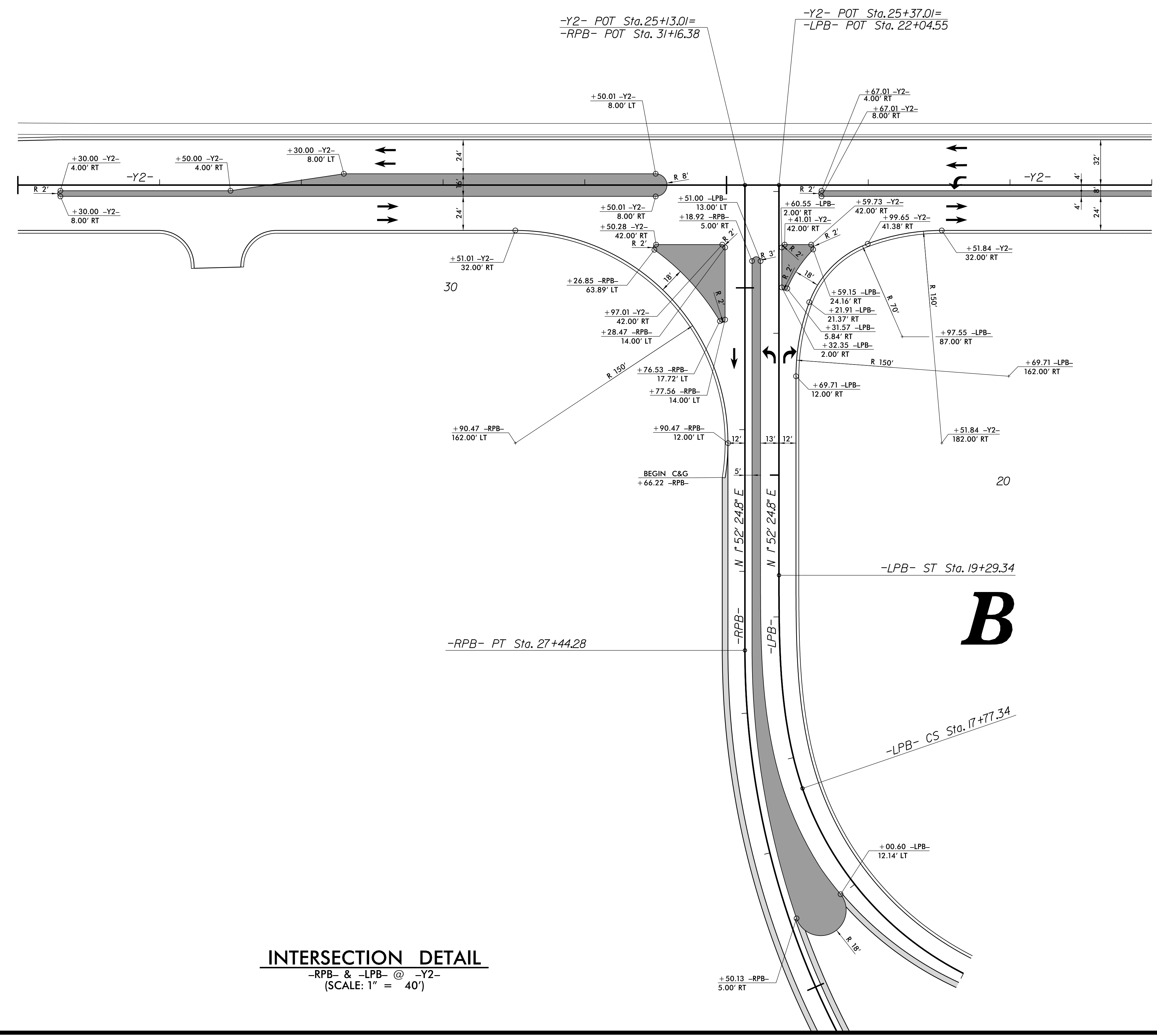
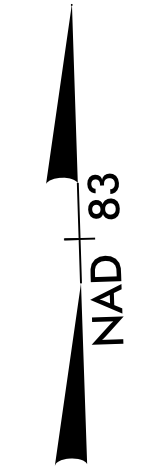

**INTERSECTION DETAIL**  
-RPB- & -LPB- @ -Y2-  
(SCALE: 1" = 40')

6/15/2021 9:20:41 AM  
C:\Users\jmorley\OneDrive\Documents\2022\2233BB\2B-1.dgn







5/14/2022

R/W SHEET NO.	HYDRAULICS ENGINEER
ROADWAY DESIGN ENGINEER	
NOT A CERTIFIED DOCUMENT AS TO THE ORIGINAL DOCUMENT BUT ONLY AS TO THE REVISIONS.	
THIS DOCUMENT ORIGINALLY ISSUED AND SEALED BY:	
DENNIS J. MORY	
PE# 020031 ON 6/15/2021	
THIS DOCUMENT IS ONLY CERTIFIED AS TO THE REVISIONS.	

**DOCUMENT NOT CONSIDERED FINAL UNLESS ALL SIGNATURES COMPLETED**

ROADWAY DESIGN ENGINEER

Bryan Lambeth  
 038648  
 NORTH CAROLINA PROFESSIONAL ENGINEER  
 SEAL  
 STATE OF NORTH CAROLINA  
 LICENSE NO. 038648  
 EXPIRES 12/31/2024

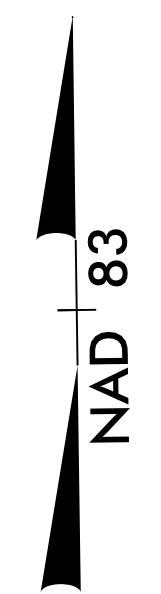

REVISIONS  
 CONSTRUCTION REV - APRIL 29, 2022 - Revised payment width of -DR3- to be 20' and increased radii of driveway tie to -Y3- to accommodate WB-62. Also pulled back nose of concrete island along -Y3- at -DR3- to allow left turn of a WB-62 onto -Y3-

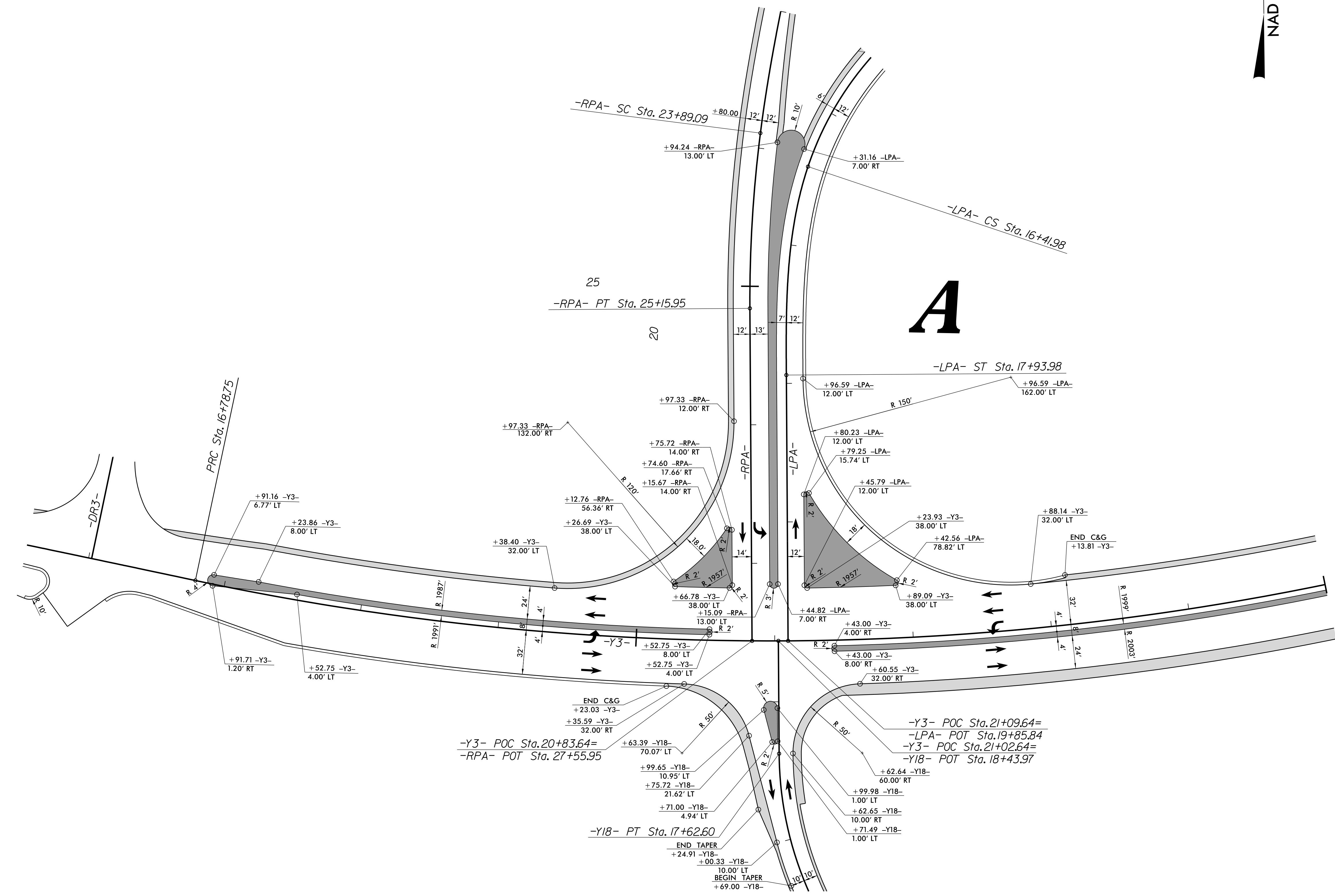

4/29/2022 10:45 PM  
 L:\EST\103\2233BB\_Rdy.dtl\_2B-3.dgn

**INTERSECTION DETAIL**  
 -RPA- & -LPA- @ -Y3-  
 (SCALE: 1" = 40')



5/14/2022

R/W SHEET NO.	
ROADWAY DESIGN ENGINEER	HYDRAULICS ENGINEER
NOT A CERTIFIED DOCUMENT AS TO THE ORIGINAL DOCUMENT BUT ONLY AS TO THE REVISIONS.	
THIS DOCUMENT ORIGINALLY ISSUED AND SEALED BY:	
DENNIS J. MORY	
PE# 020031 ON 6/15/2021	
THIS DOCUMENT IS ONLY CERTIFIED AS TO THE REVISIONS.	

**DOCUMENT NOT CONSIDERED FINAL UNLESS ALL SIGNATURES COMPLETED**

ROADWAY DESIGN ENGINEER

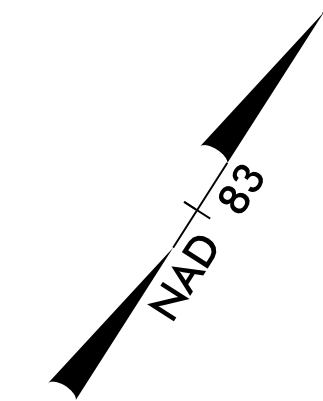

REVISIONS  
CONSTRUCTION REV. - APRIL 29, 2022 - Revised alignment and widths of -TR1- and -TR2-. Removed channelized island in north corner of intersection and pulled back island nose along -Y3- on northeast approach to intersection. Added curb and gutter to east side of intersection to accommodate redesign of -TR1- curb ramps.

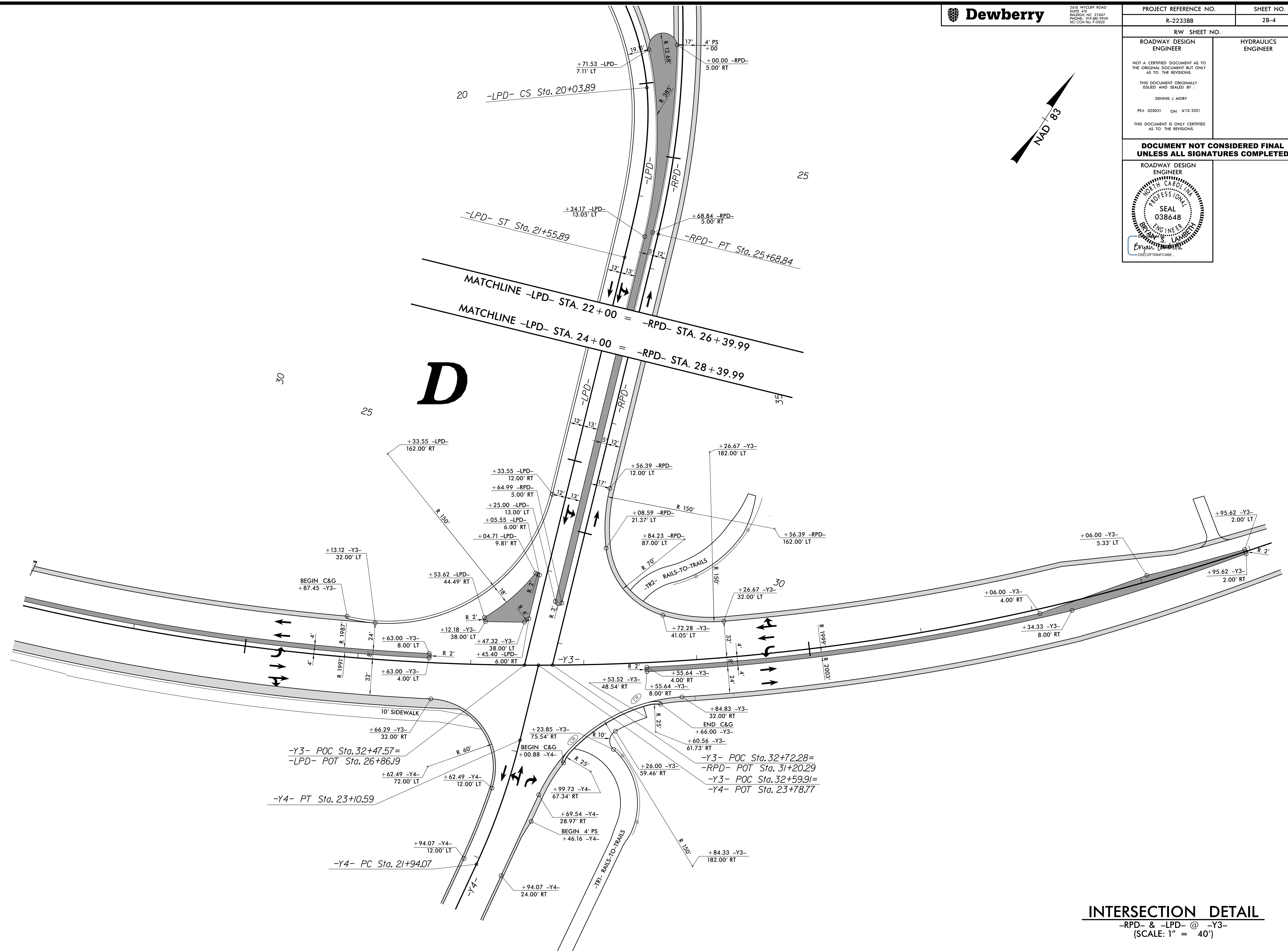

**INTERSECTION DETAIL**  
-RPD- & -LPD- @ -Y3-  
(SCALE: 1" = 40')

4/29/2022 10:34:06 PM  
LISTENING TO R2233BB-Rdy.dtl\_2B-4.dgn



PROJECT REFERENCE NO. R-2233BB	SHEET NO. 28-5
RW SHEET NO.	
ROADWAY DESIGN ENGINEER	HYDRAULICS ENGINEER
6/15/2021	

**DOCUMENT NOT CONSIDERED FINAL  
UNLESS ALL SIGNATURES COMPLETED**

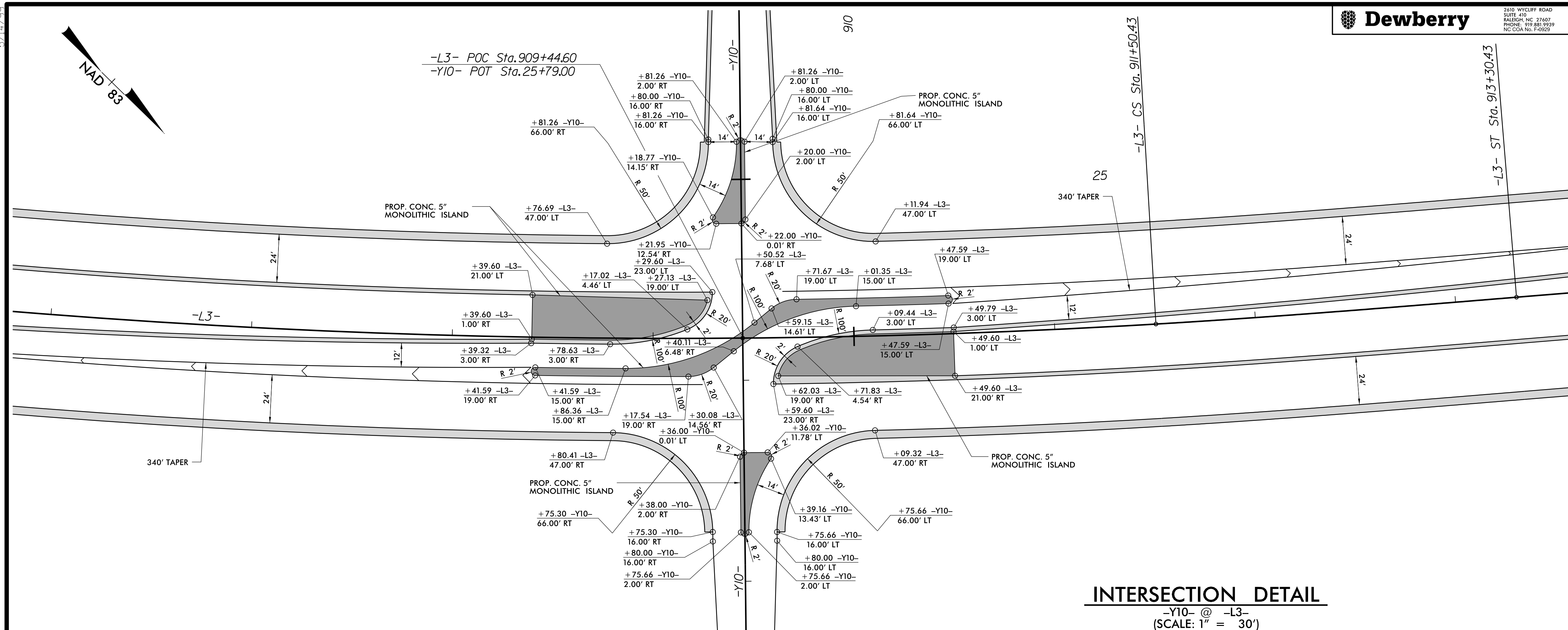

**INTERSECTION DETAIL**  
-Y10 @ -L3  
(SCALE: 1" = 30')

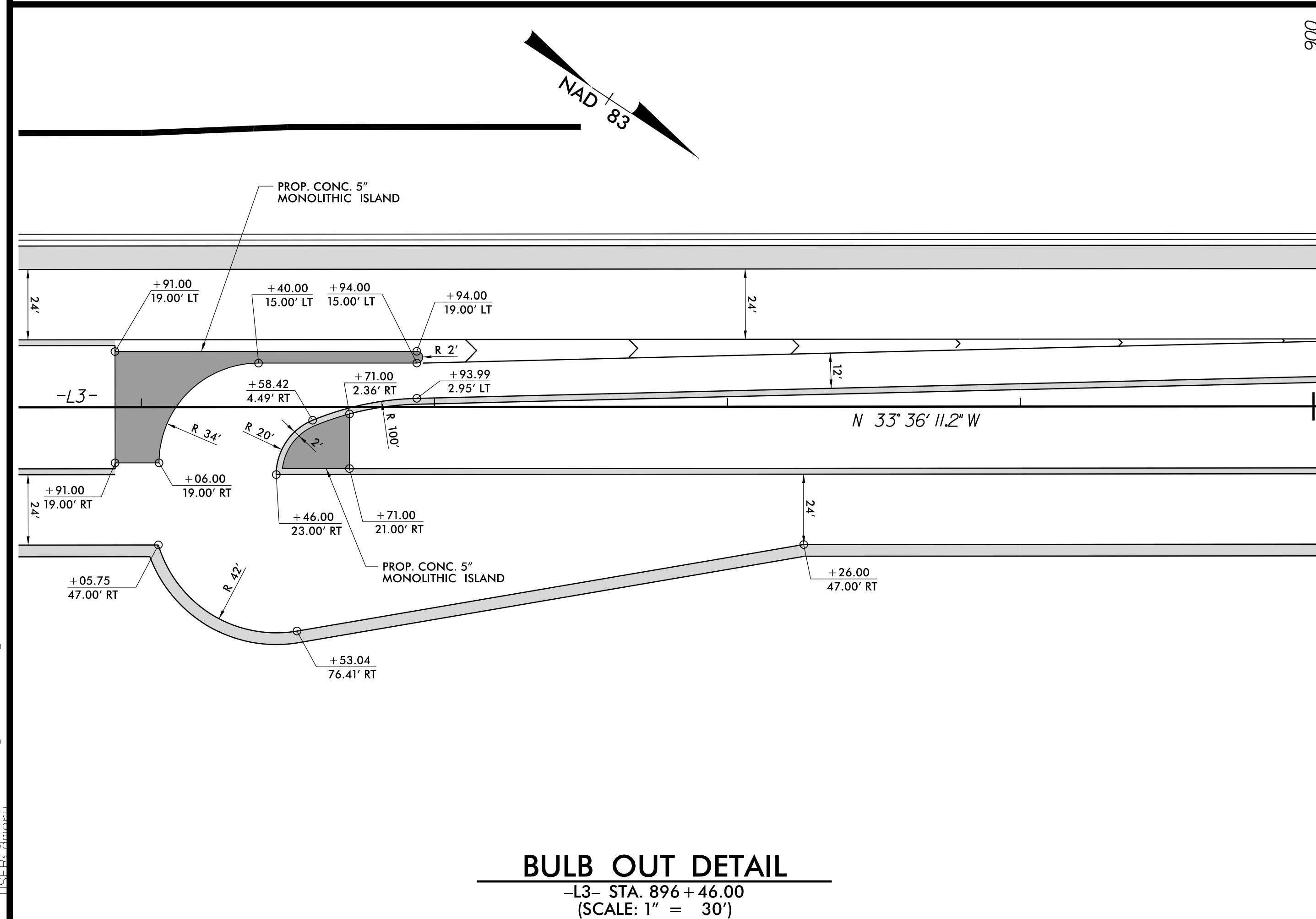

**BULB OUT DETAIL**  
-L3 STA. 896 + 46.00  
(SCALE: 1" = 30')

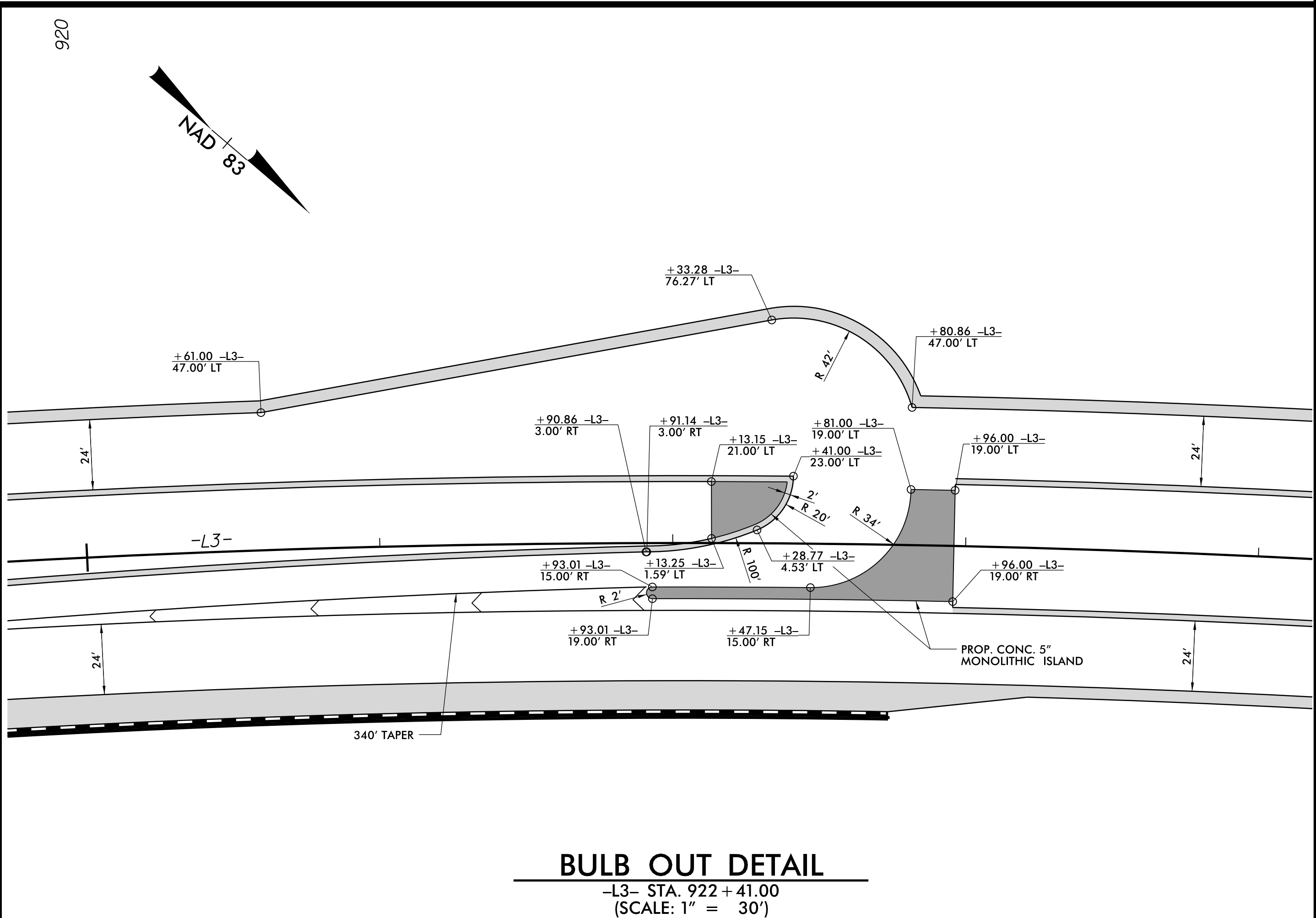

**BULB OUT DETAIL**  
-L3 STA. 922 + 41.00  
(SCALE: 1" = 30')

5/14/2021  
6/15/2021 9:05:07 AM  
T:\Projects\2233BB\28-5.dgn



5/14/2021



2610 WYCLIFF ROAD  
SUITE 410  
RALEIGH, NC 27607  
PHONE: 919.881.9999  
NC COA No. F-09251

PROJECT REFERENCE NO. R-2233BB	SHEET NO. 2B-6
RW SHEET NO.	
ROADWAY DESIGN ENGINEER Dewberry 020031 6/15/2021	HYDRAULICS ENGINEER

DOCUMENT NOT CONSIDERED FINAL  
UNLESS ALL SIGNATURES COMPLETED

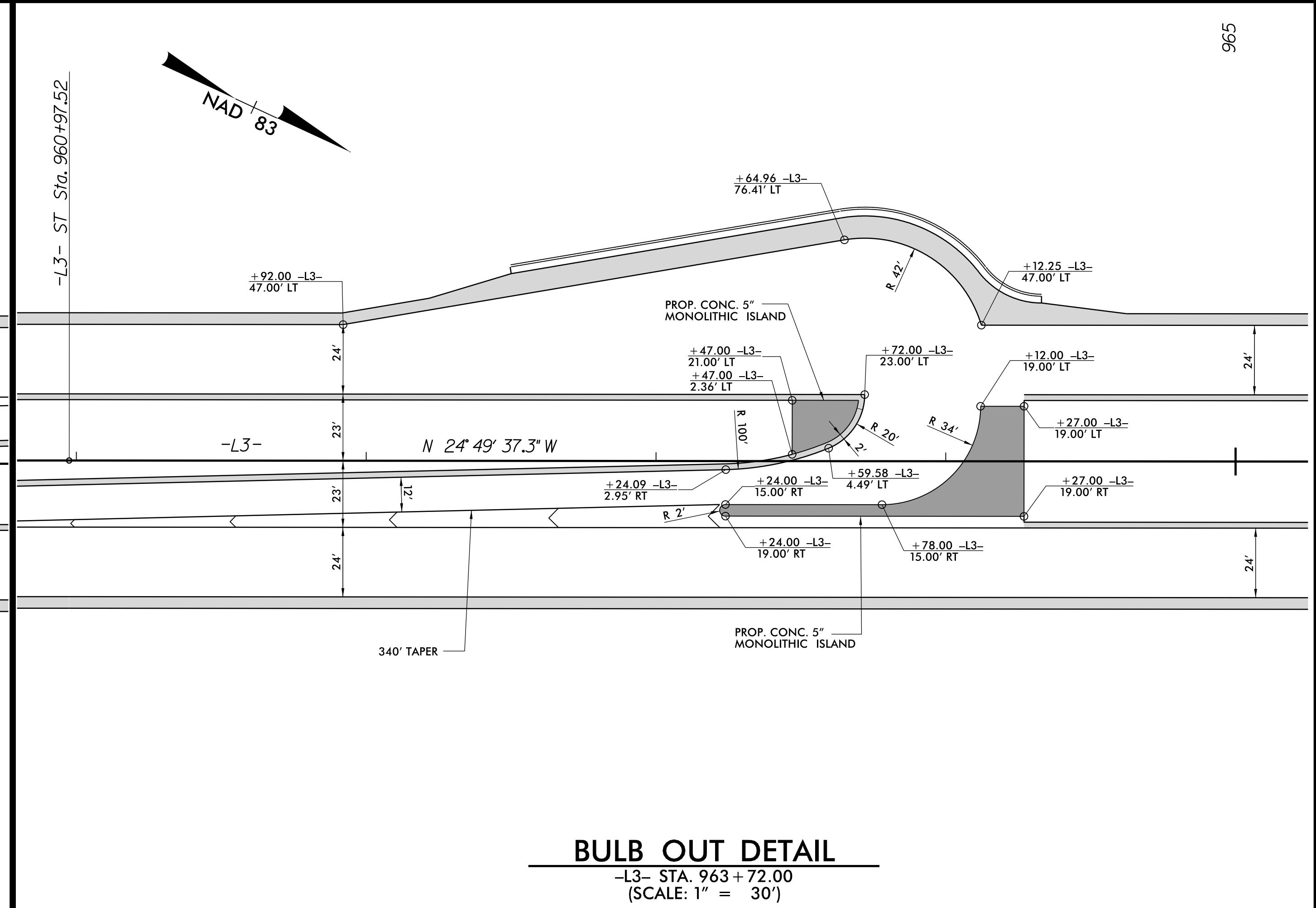
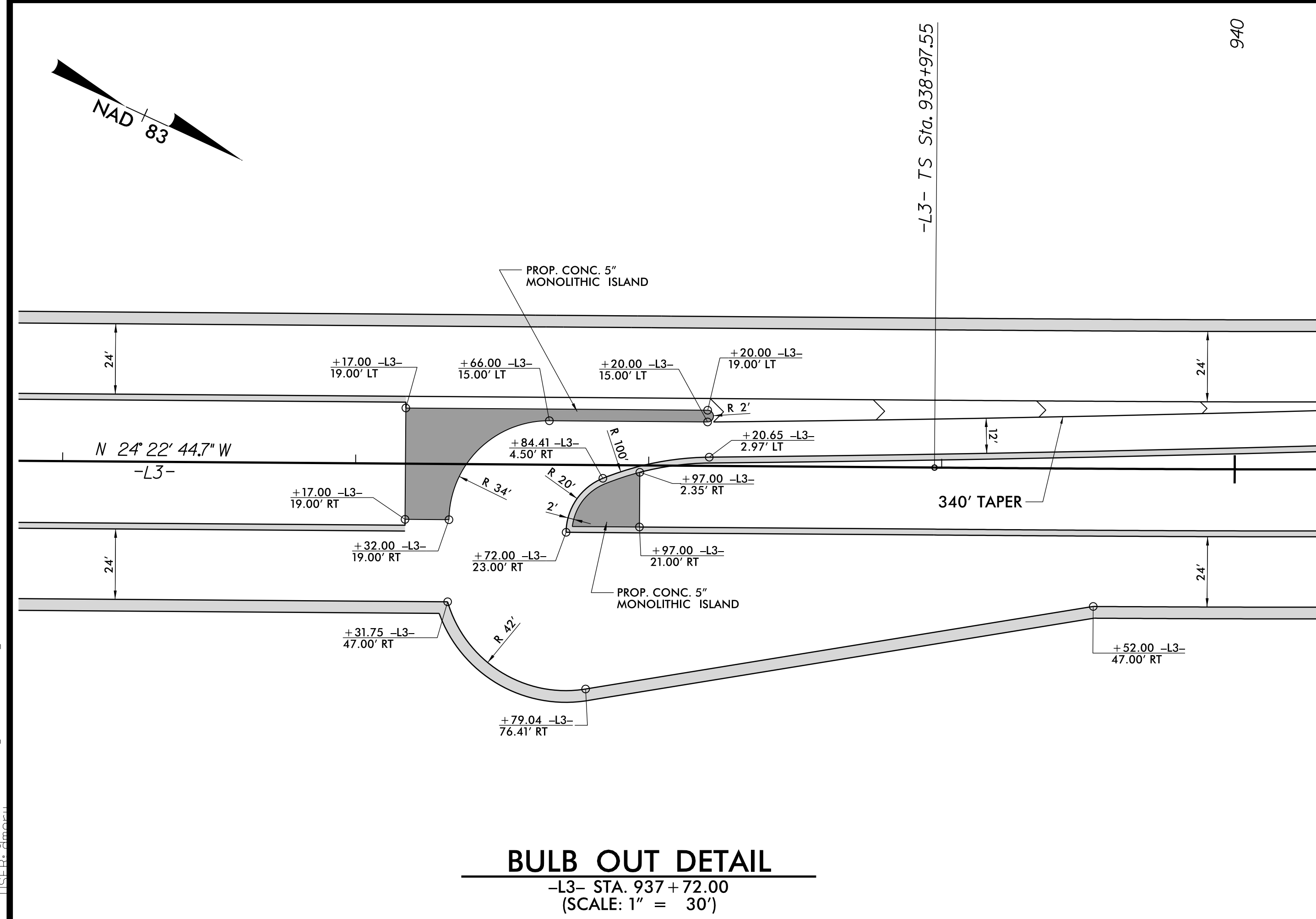
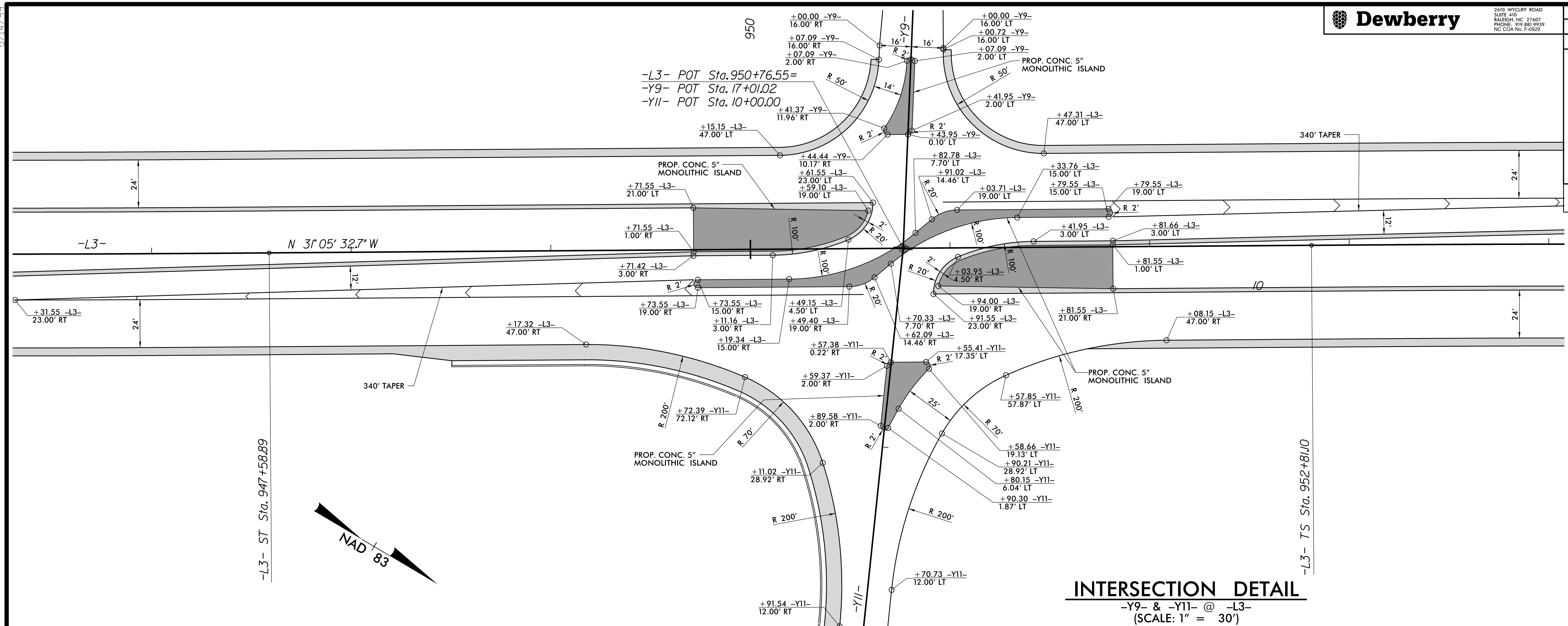

6/15/2021 9:05:21 AM  
TitleBlock.dwg - Rdy - dtl - 2B-6.dgn



5/14/2021



2610 WYCLIFF ROAD  
SUITE 410  
RALEIGH, NC 27607  
PHONE: 919.881.9999  
NC COA No. F-09251

PROJECT REFERENCE NO. R-2233BB	SHEET NO. 2B-7
ROADWAY DESIGN ENGINEER	HYDRAULICS ENGINEER
DOCUMENT NOT CONSIDERED FINAL UNLESS ALL SIGNATURES COMPLETED	

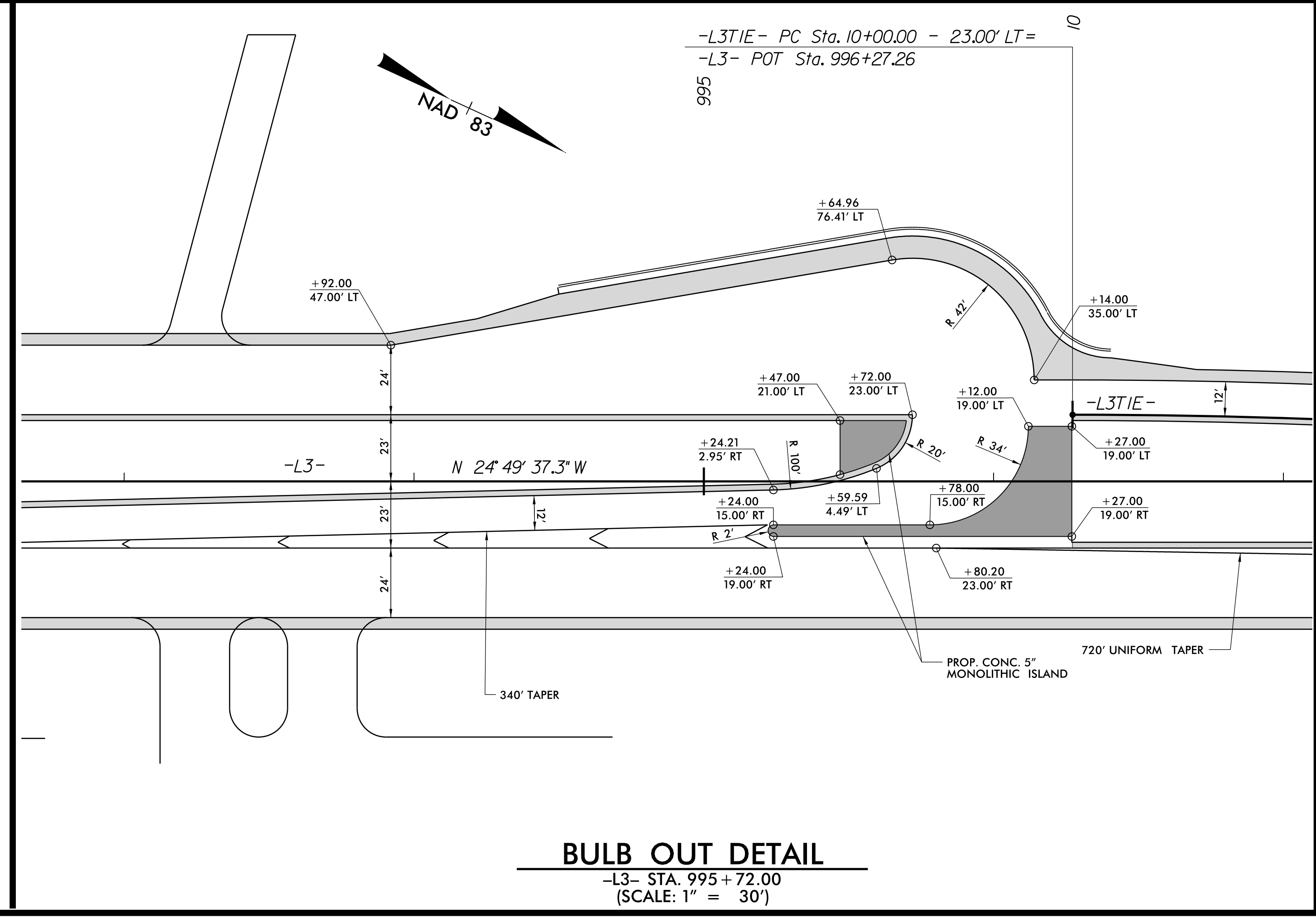
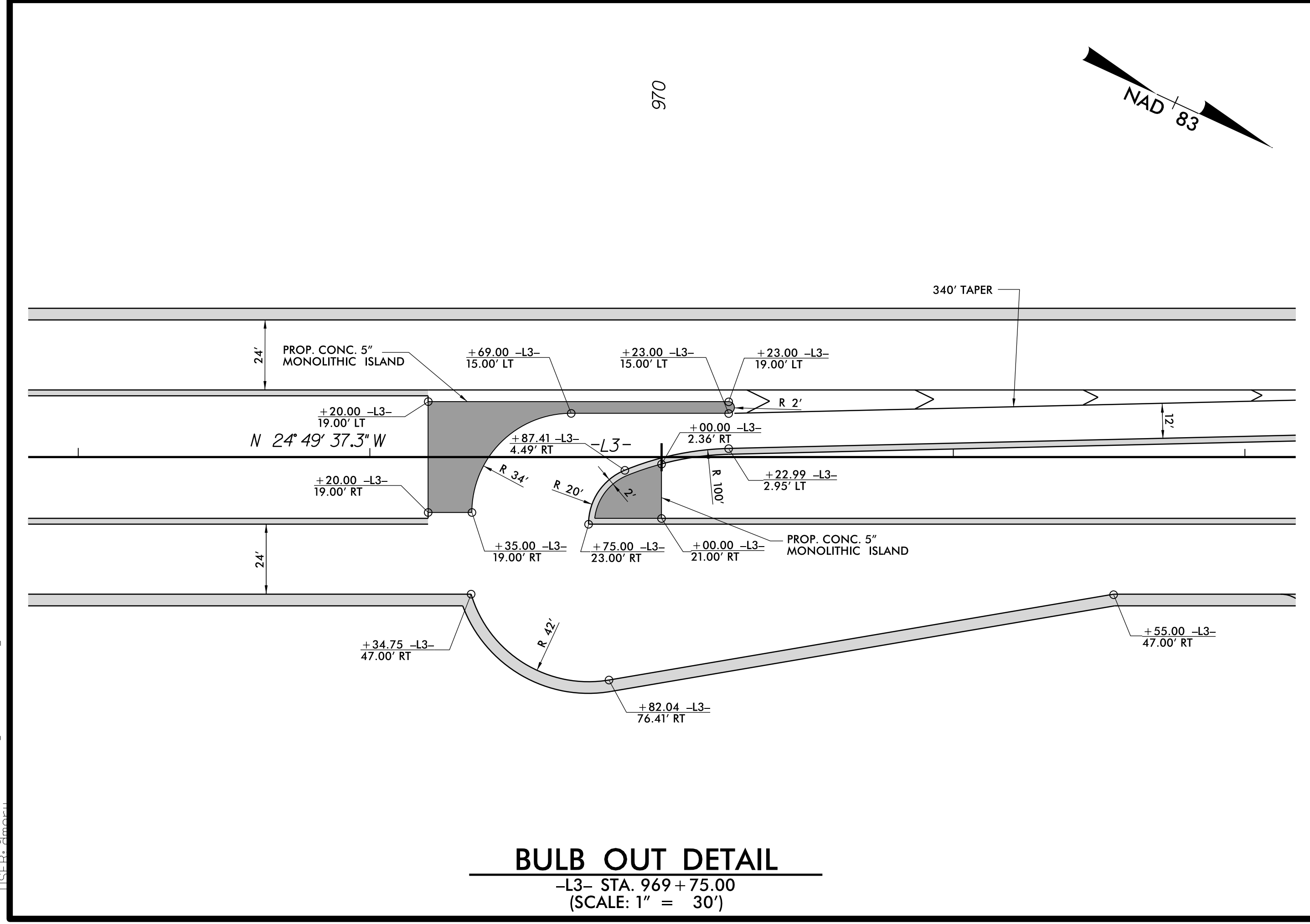
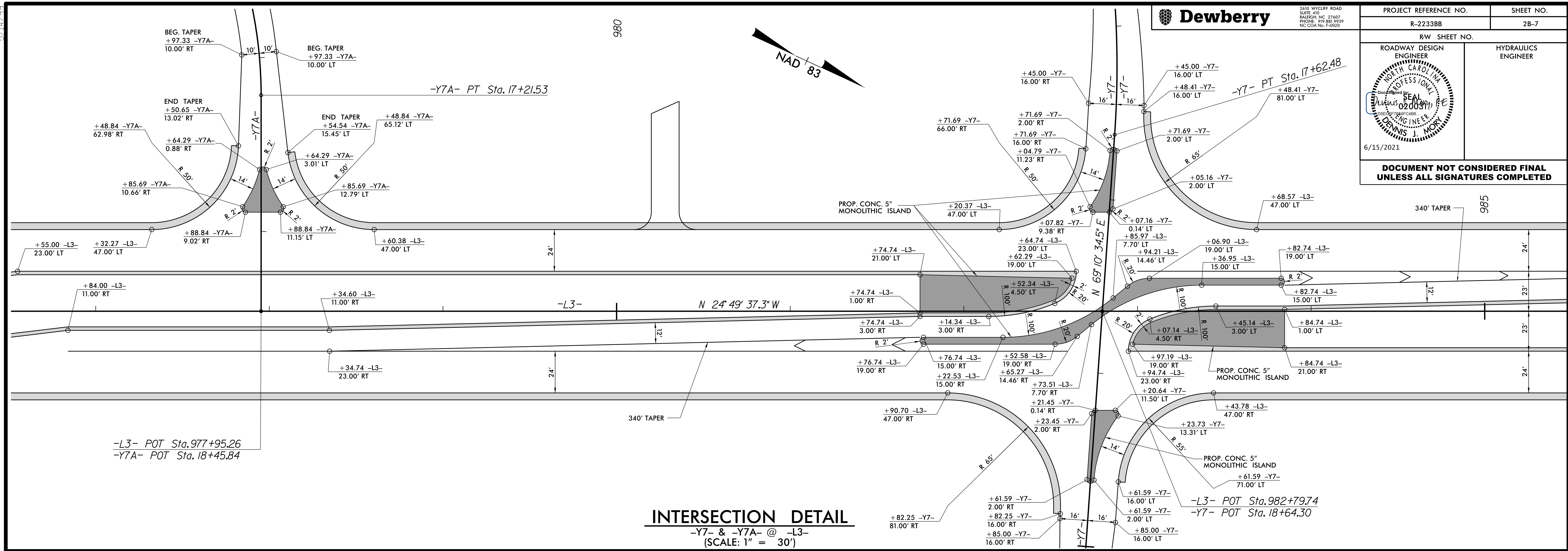

6/15/2021 9:07:21 AM  
Title: R-2233BB - Rdwy\_dtl\_2B-7.dgn



5/14/2021

20



2610 WYCLIFF ROAD  
SUITE 410  
RALEIGH, NC 27607  
PHONE: 919.881.9999  
NC COA No. F-09251

PROJECT REFERENCE NO. R-2233BB		SHEET NO. 2B-8
RW SHEET NO.		HYDRAULICS ENGINEER
ROADWAY DESIGN ENGINEER		
6/15/2021		
<b>DOCUMENT NOT CONSIDERED FINAL UNLESS ALL SIGNATURES COMPLETED</b>		

-Y25REV- PC Sta. 19+90.04

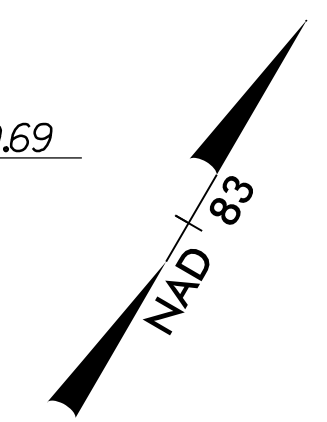
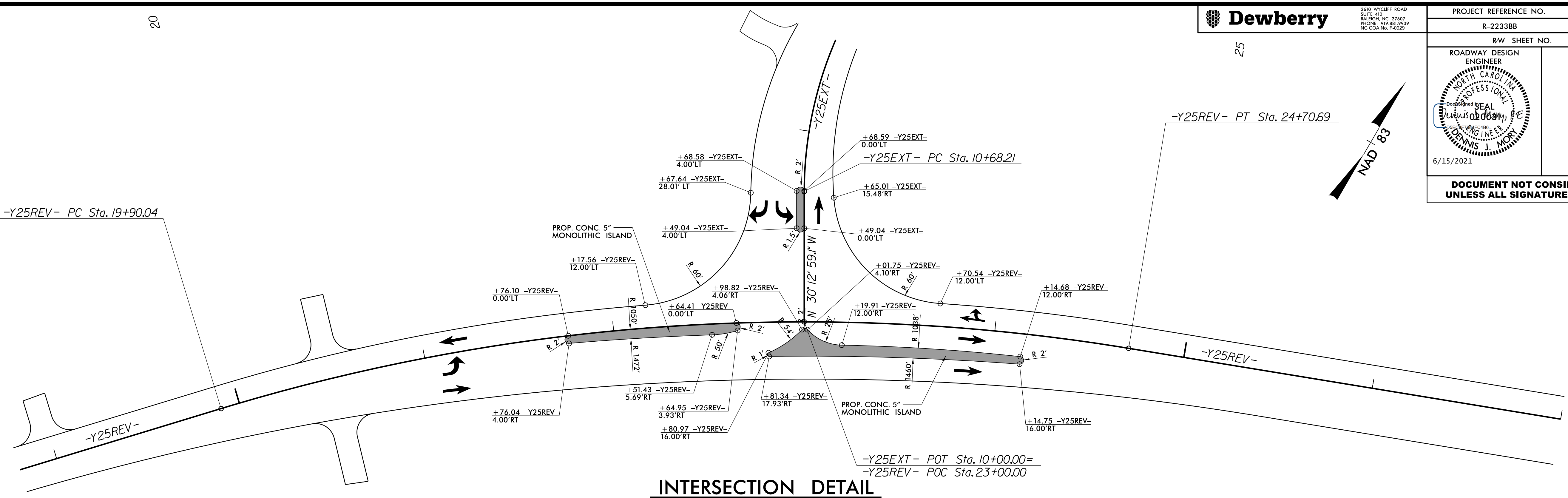

**INTERSECTION DETAIL**

-Y25REV- @ -Y25EXT-  
(SCALE: 1" = 30')

20

-Y8- PI Sta. 21+32.13=  
-Y10- POC Sta. 17+55.52

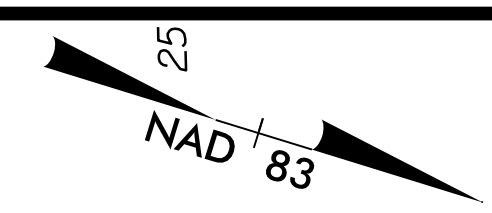
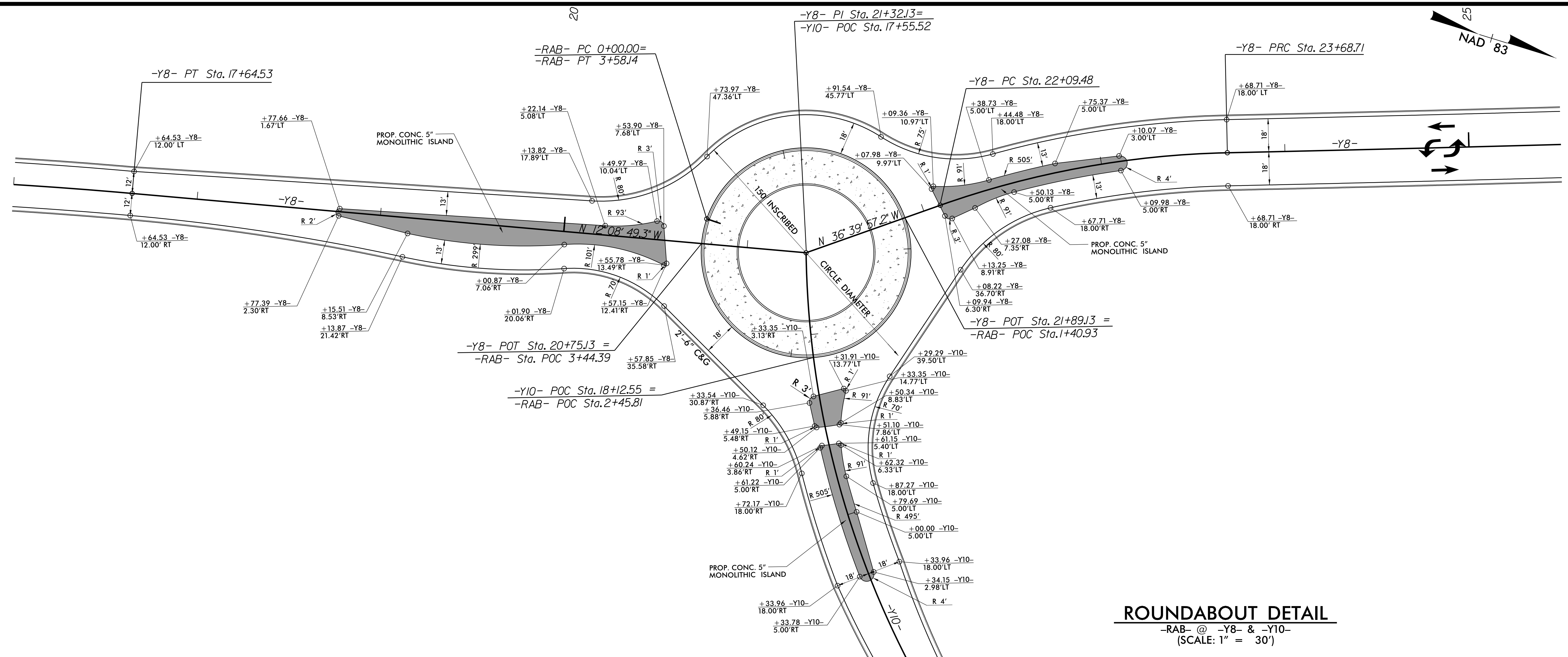

**ROUNDABOUT DETAIL**

-RAB- @ -Y8- & -Y10-  
(SCALE: 1" = 30')

6/15/2021 9:08:53 AM  
T:\Users\dmoran\OneDrive\Documents\2021\2B-8.dgn



5/14/19



2610 WYCLIFF ROAD  
SUITE 410  
RALEIGH, NC 27607  
PHONE: 919.883.9329  
NC CCA No. F-0029

PROJECT REFERENCE NO. R-2233BB		SHEET NO. 2B-9
RW SHEET NO.		
ROADWAY DESIGN ENGINEER	HYDRAULICS ENGINEER	
6/15/2021		
<b>DOCUMENT NOT CONSIDERED FINAL UNLESS ALL SIGNATURES COMPLETED</b>		

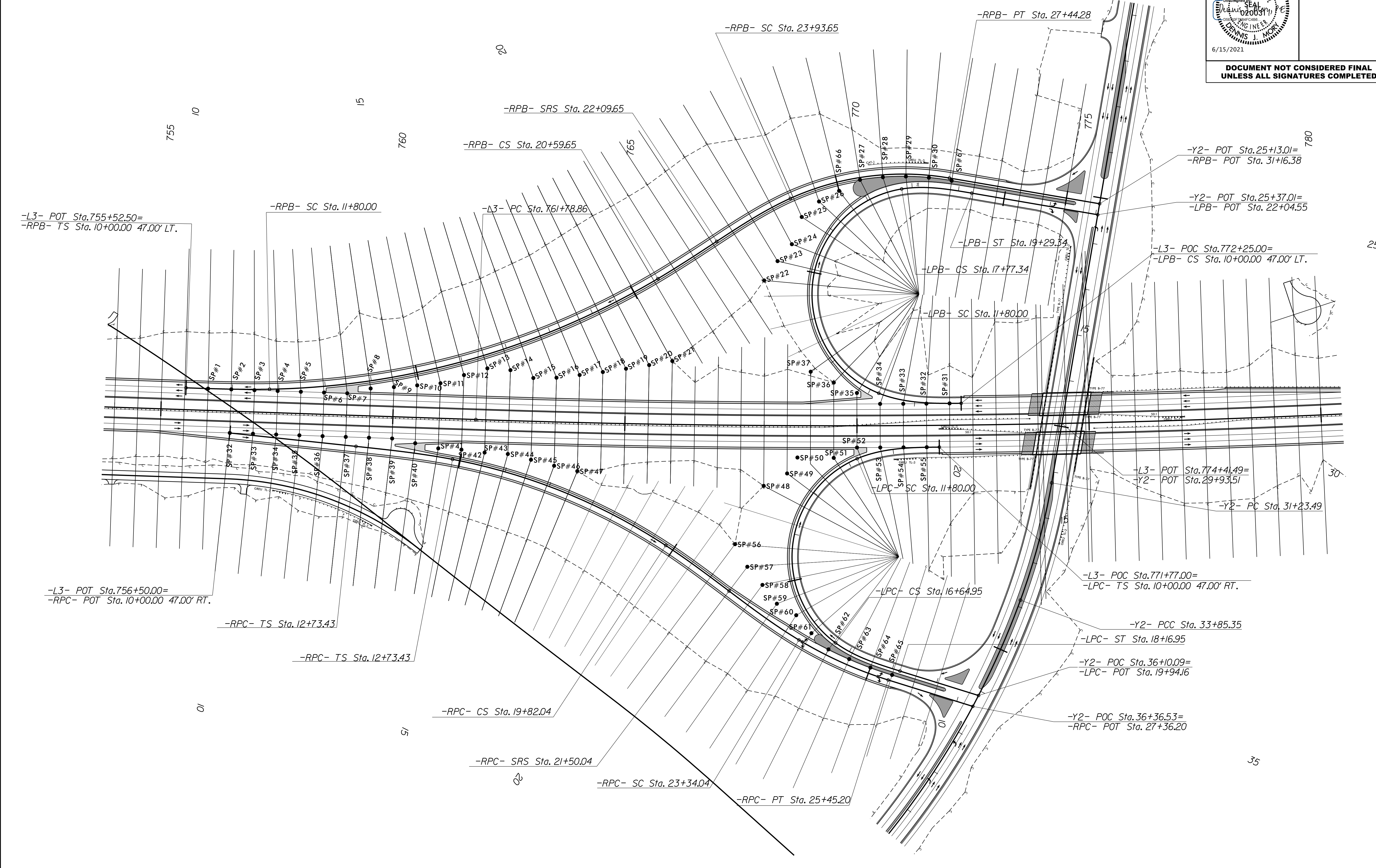
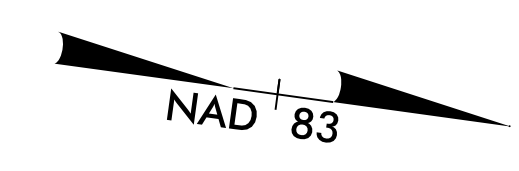

4/21/2020 3:49:57 PM  
T:\2233\223338B.Rdy\_SFD\_2B.dgn

35



PROJECT REFERENCE NO. R-2233BB	SHEET NO. 2B-10
RW SHEET NO.	
ROADWAY DESIGN ENGINEER	HYDRAULICS ENGINEER
6/15/2021	
<b>DOCUMENT NOT CONSIDERED FINAL UNLESS ALL SIGNATURES COMPLETED</b>	

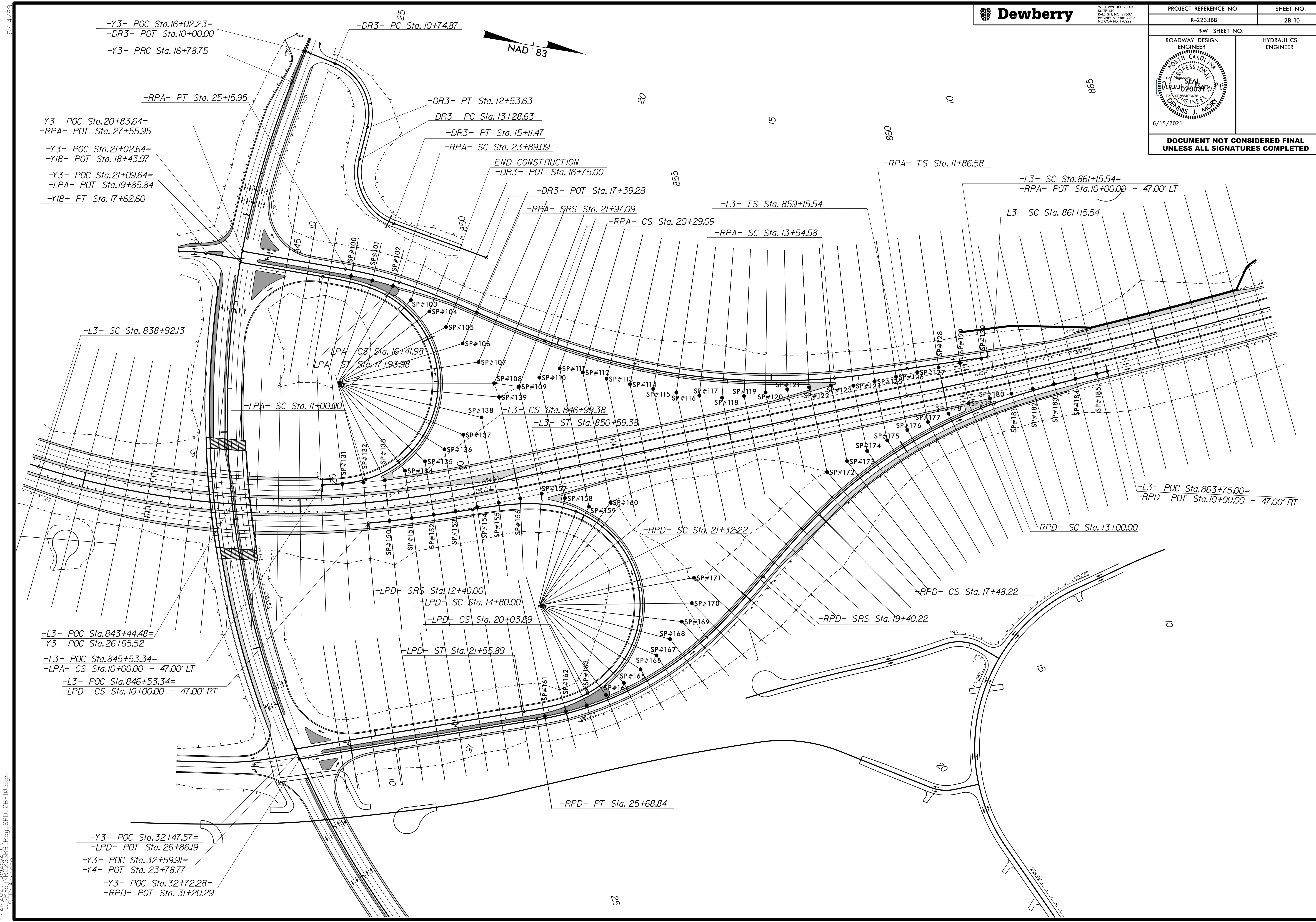

5/14/19  
4/21/2020 3:42:02 PM  
I:\SEF\J\N2233BB-Rwy-SPD\_2B-10.dgn



5/14/2021



2610 WYCLIFF ROAD  
SUITE 410  
RALEIGH, NC 27603  
PHONE: 919.881.9999  
NC COA No. F-09291

PROJECT REFERENCE NO.	SHEET NO.
R-2233BB	2B-11

RW SHEET NO.

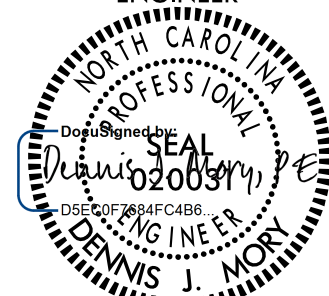
ROADWAY DESIGN ENGINEER	HYDRAULICS ENGINEER
	
6/15/2021	

DOCUMENT NOT CONSIDERED FINAL  
UNLESS ALL SIGNATURES COMPLETED

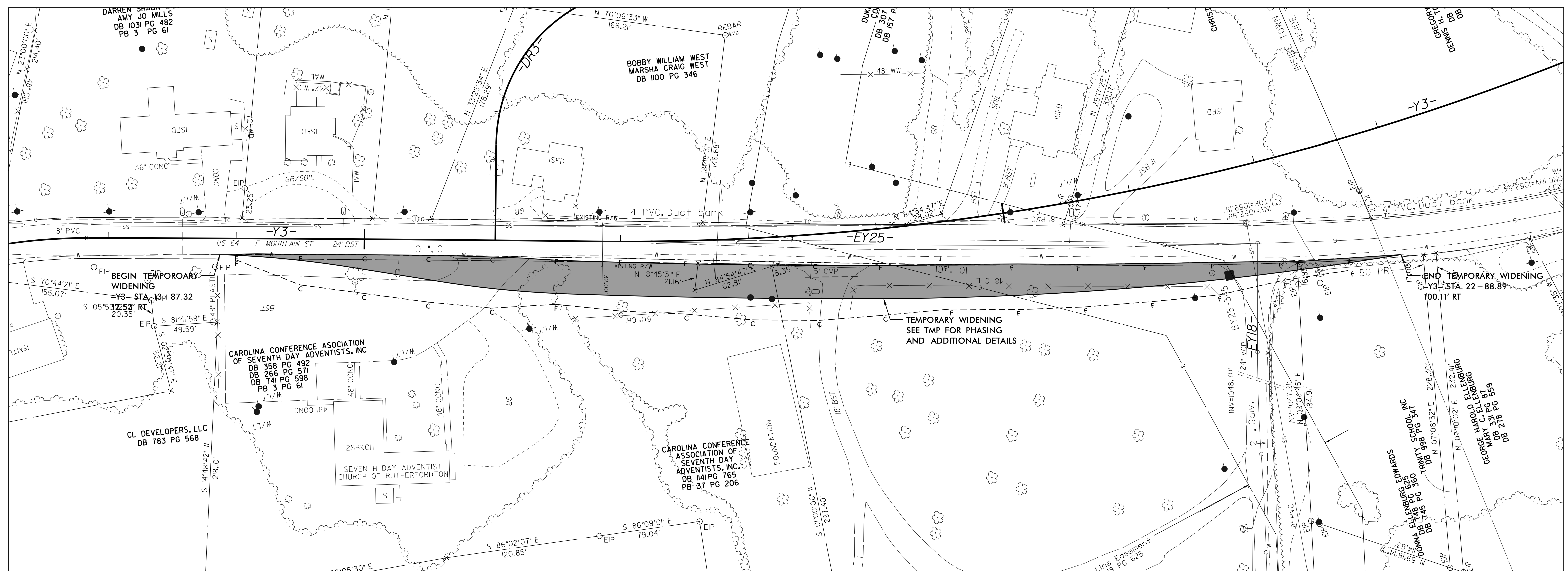

-Y3- TEMPORARY WIDENING DETAIL - RT

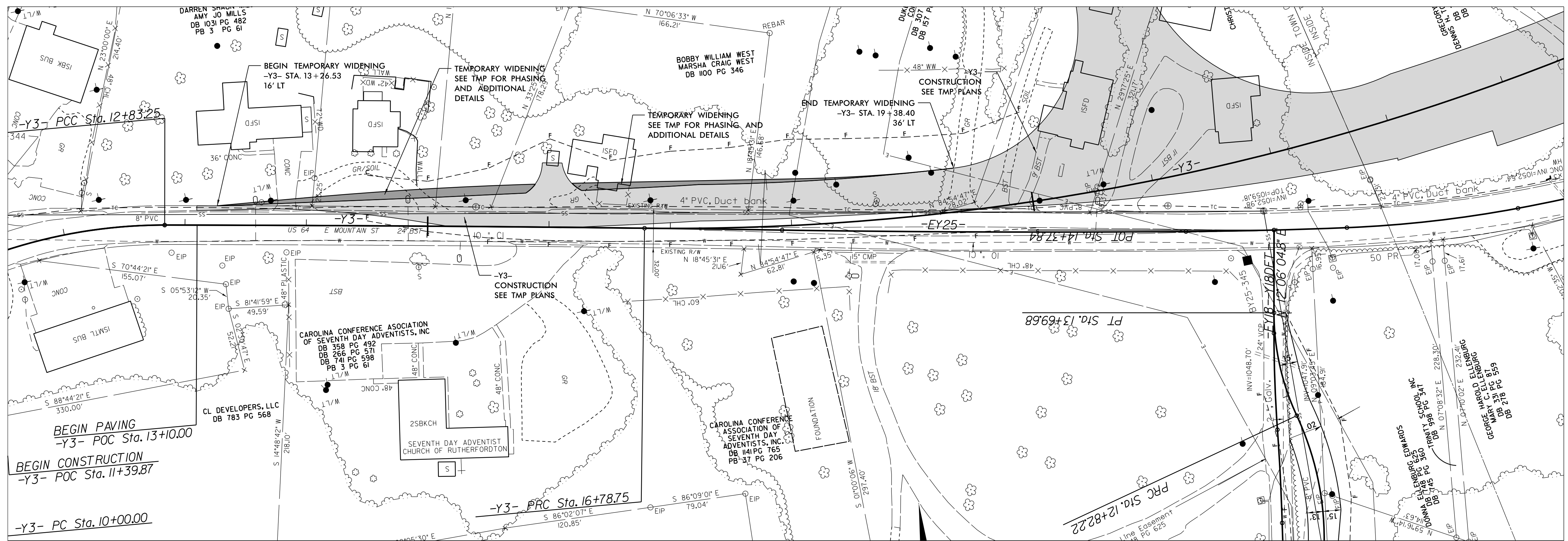
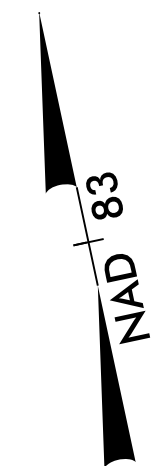

-Y3- TEMPORARY WIDENING DETAIL - LT



6/15/2021 9:30:58 AM d41\_2B-11 Det.dgn





2610 WYCLIFF ROAD  
SUITE 410  
RALEIGH, NC 27607  
PHONE: 919.881.9999  
NC COA No. F.09291

PROJECT REFERENCE NO. R-2233BB	SHEET NO. 2B-12
RW SHEET NO.	
ROADWAY DESIGN ENGINEER	
6/15/2021	
DOCUMENT NOT CONSIDERED FINAL UNLESS ALL SIGNATURES COMPLETED	

**CURVE DATA FOR -Y18DET-**

PI Sta 10+50.17	PI Sta 11+95.34	PI Sta 13+26.66
$\Delta = 22^\circ 41' 40.1''$ (RT)	$\Delta = 43^\circ 44' 03.4''$ (LT)	$\Delta = 25^\circ 03' 27.7''$ (RT)
D = 22' 55' 05.9"	D = 23' 52' 23.7"	D = 28' 38' 52.4"
L = 99.02'	L = 183.19'	L = 87.47'
T = 50.17'	T = 96.32'	T = 44.44'
R = 250.00'	R = 240.00'	R = 200.00'

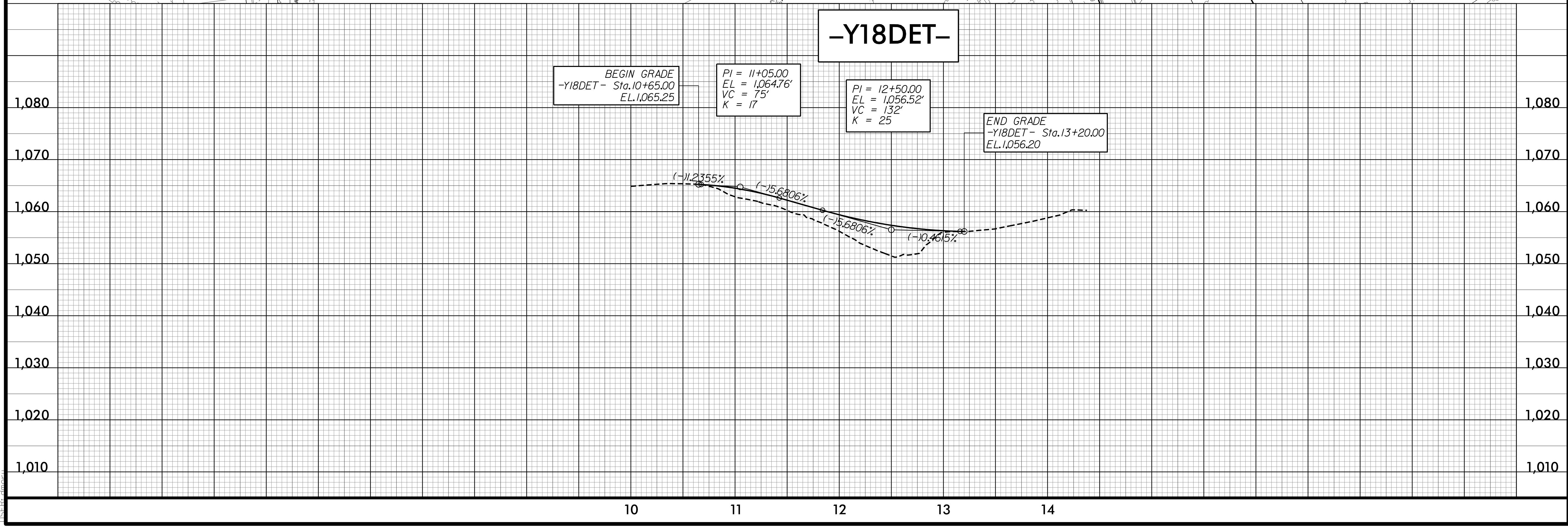
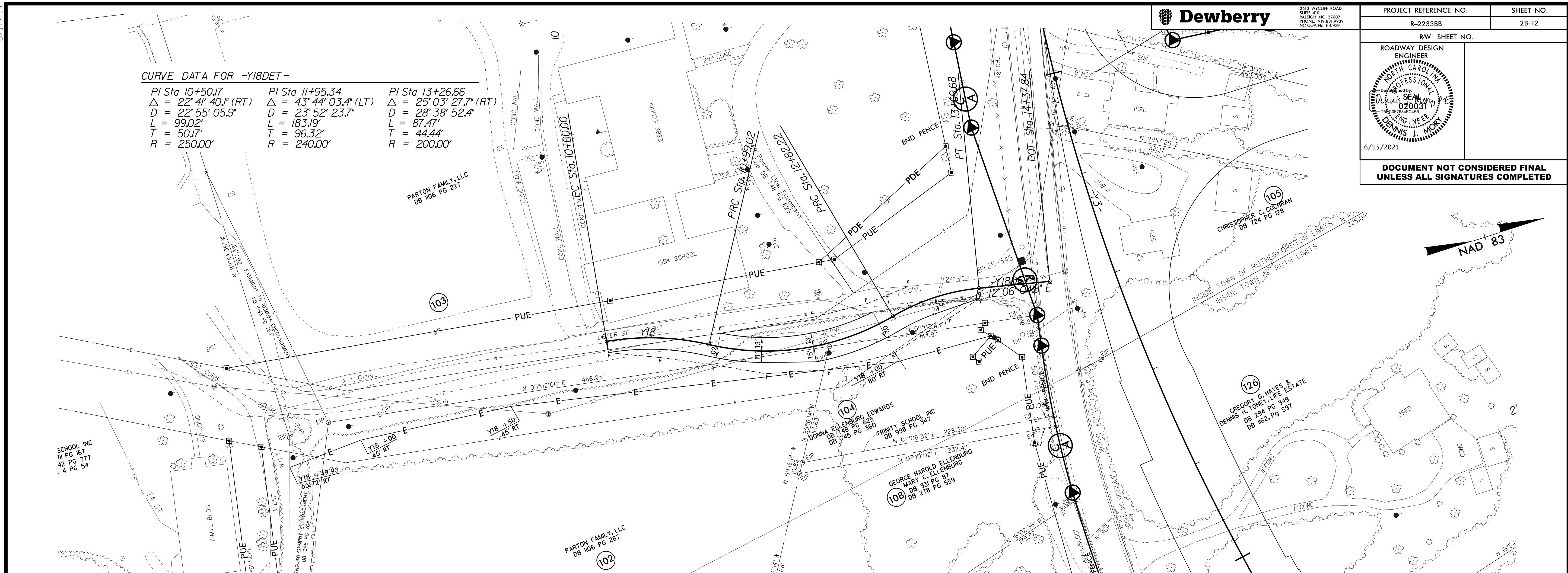



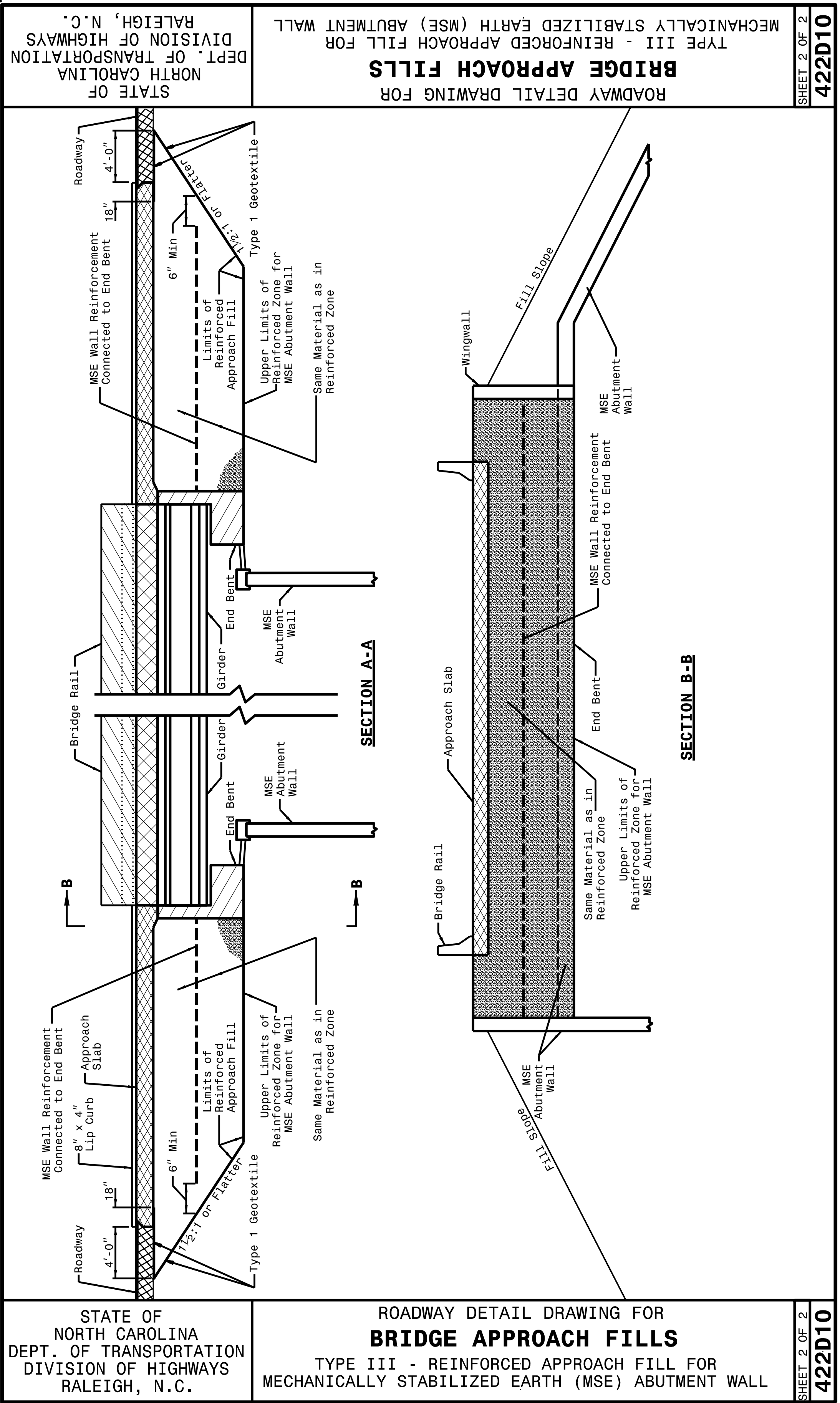
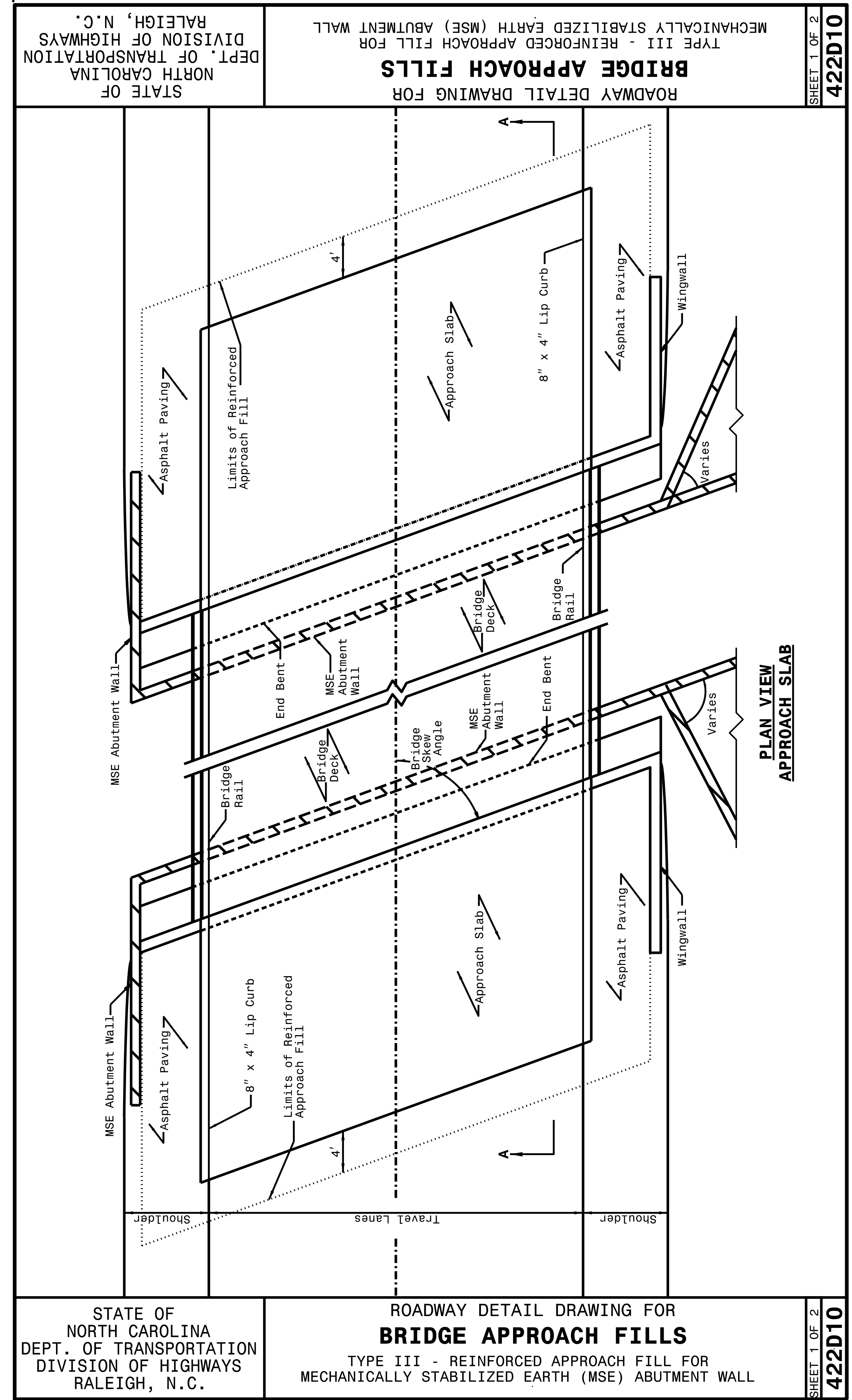

6/15/2021

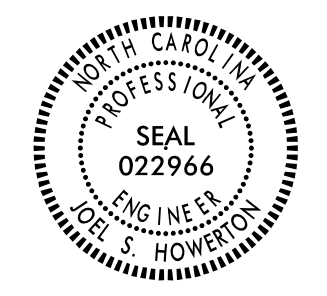

DocuSigned by: James S. Hunt 873F3D11DC0C45F

DOCUMENT NOT CONSIDERED FINAL UNLESS ALL SIGNATURES COMPLETED

**CONTRACTS STANDARDS AND DEVELOPMENT UNIT**  
 Office 919-707-6950 FAX 919-250-4119

**TYPE III REINFORCED APPROACH FILLS**

ORIGINAL BY: K. A. KEMPF DATE: JULY 2017  
 MODIFIED BY: DATE:  
 CHECKED BY: DATE:  
 FILE SPEC.: 2018 standard drawings\division 422d10.dgn



I4-DEC-2017 10:36  
 S:\Contracts\Special Details\Standard Drawings\Details in Lieu of Standards\Division 8\0862d0301.dgn  
 Jhowerton AT CSU-292895

STATE OF NORTH CAROLINA DEPT. OF TRANSPORTATION DIVISION OF HIGHWAYS RALEIGH, N.C.	ROADWAY DETAIL DRAWING FOR <b>STRUCTURE ANCHOR UNITS</b> GUARDRAIL ANCHOR UNIT, TYPE III FOR ATTACHMENT TO RAIL ON BRIDGE	SHEET 1 OF 7 <b>862D03</b>
<p><b>NOTE:</b></p> <ul style="list-style-type: none"> <li>**POST NOT REQUIRED FOR SKEW ANGLES GREATER THAN 150° OR LESS THAN 30° UNLESS OTHERWISE DIRECTED BY THE ENGINEER.</li> <li>*THE DISTANCE FROM END OF BRIDGE RAIL TO CENTER LINE OF THE FIRST POST SHOULD BE 11½" IF CONCRETE BACKWALL IS NOT PRESENT.</li> <li>-SHOULDER BERM GUTTER MUST BE INSTALLED TO THE LIMITS 8" x 4" LIP CURB IS SHOWN IF ANCHOR UNIT IS NOT ADJACENT TO AN APPROACH SLAB.</li> <li>-MEASURE GUARDRAIL HEIGHT FROM THE TOP OF ADJACENT SURFACE (SHOULDER, BERM, OR GUTTER).</li> <li>-LAP JOINTS IN THE DIRECTION OF TRAFFIC FLOW.</li> <li>-SEE SHEET 3 FOR POST SECTIONS 1 THRU 9.</li> </ul>		
<b>GUARDRAIL ANCHOR UNIT, TYPE III          FOR ATTACHMENT TO RAIL ON BRIDGE</b>		

STATE OF NORTH CAROLINA DEPT. OF TRANSPORTATION DIVISION OF HIGHWAYS RALEIGH, N.C.	ROADWAY DETAIL DRAWING FOR <b>STRUCTURE ANCHOR UNITS</b> GUARDRAIL ANCHOR UNIT, TYPE III FOR ATTACHMENT TO RAIL ON BRIDGE - SUB REGIONAL TIER	SHEET 2 OF 7 <b>862D03</b>
<p><b>NOTE:</b></p> <ul style="list-style-type: none"> <li>**POST NOT REQUIRED FOR SKEW ANGLES GREATER THAN 150° OR LESS THAN 30° UNLESS OTHERWISE DIRECTED BY THE ENGINEER.</li> <li>*THE DISTANCE FROM END OF BRIDGE RAIL TO CENTER LINE OF THE FIRST POST SHOULD BE 11½" IF CONCRETE BACKWALL IS NOT PRESENT.</li> <li>-SHOULDER BERM GUTTER MUST BE INSTALLED TO THE LIMITS 8" x 4" LIP CURB IS SHOWN IF ANCHOR UNIT IS NOT ADJACENT TO AN APPROACH SLAB.</li> <li>-MEASURE GUARDRAIL HEIGHT FROM THE TOP OF ADJACENT SURFACE (SHOULDER, BERM, OR GUTTER).</li> <li>-LAP JOINTS IN THE DIRECTION OF TRAFFIC FLOW.</li> <li>-SEE SHEET 3 FOR POST SECTIONS 1 THRU 9.</li> </ul>		
<b>GUARDRAIL ANCHOR UNIT, TYPE III FOR ATTACHMENT TO          RAIL ON BRIDGE - SUB REGIONAL TIER</b>		

<b>CONTRACT STANDARDS          AND DEVELOPMENT UNIT</b> Office 919-707-6950 FAX 919-250-4119	
<b>SEE TITLE BLOCK</b>	
ORIGINAL BY: J HOWERTON      DATE: 06-22-12 MODIFIED BY:                      DATE: CHECKED BY:                        DATE: FILE SPEC.:                         DATE:	<div style="text-align: center;"> </div> <p style="text-align: center; font-size: small;">         DOCUMENT NOT CONSIDERED FINAL          UNLESS ALL SIGNATURES COMPLETED       </p>



STATE OF NORTH CAROLINA  
DEPT. OF TRANSPORTATION  
DIVISION OF HIGHWAYS  
RALEIGH, N.C.

ROADWAY DETAIL DRAWING FOR  
**GUARDRAIL INSTALLATION**

SHEET 6 OF 8  
**862D02**

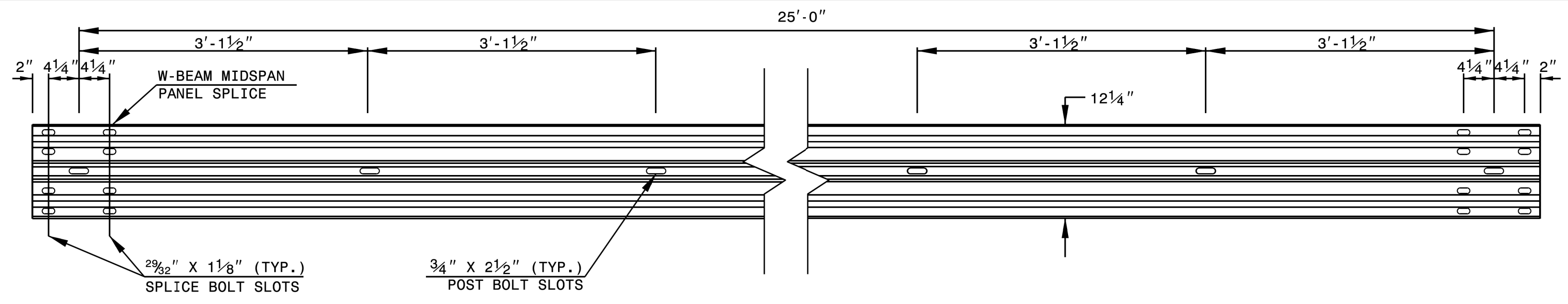

**STANDARD W-BEAM GUARDRAIL**

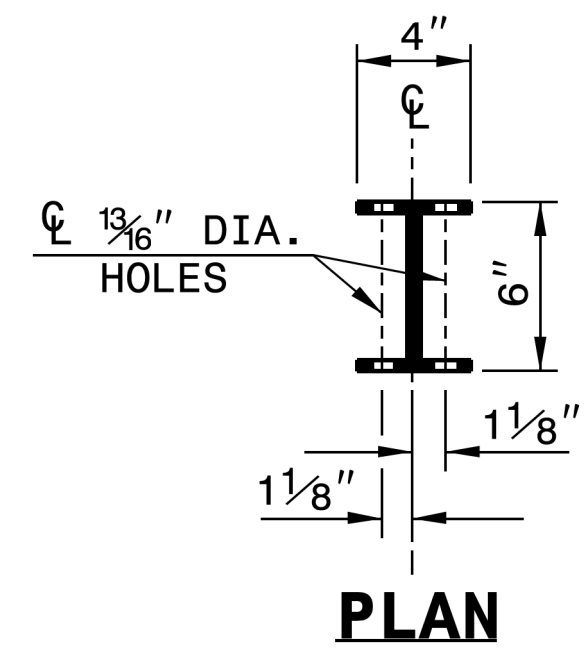

**PLAN**

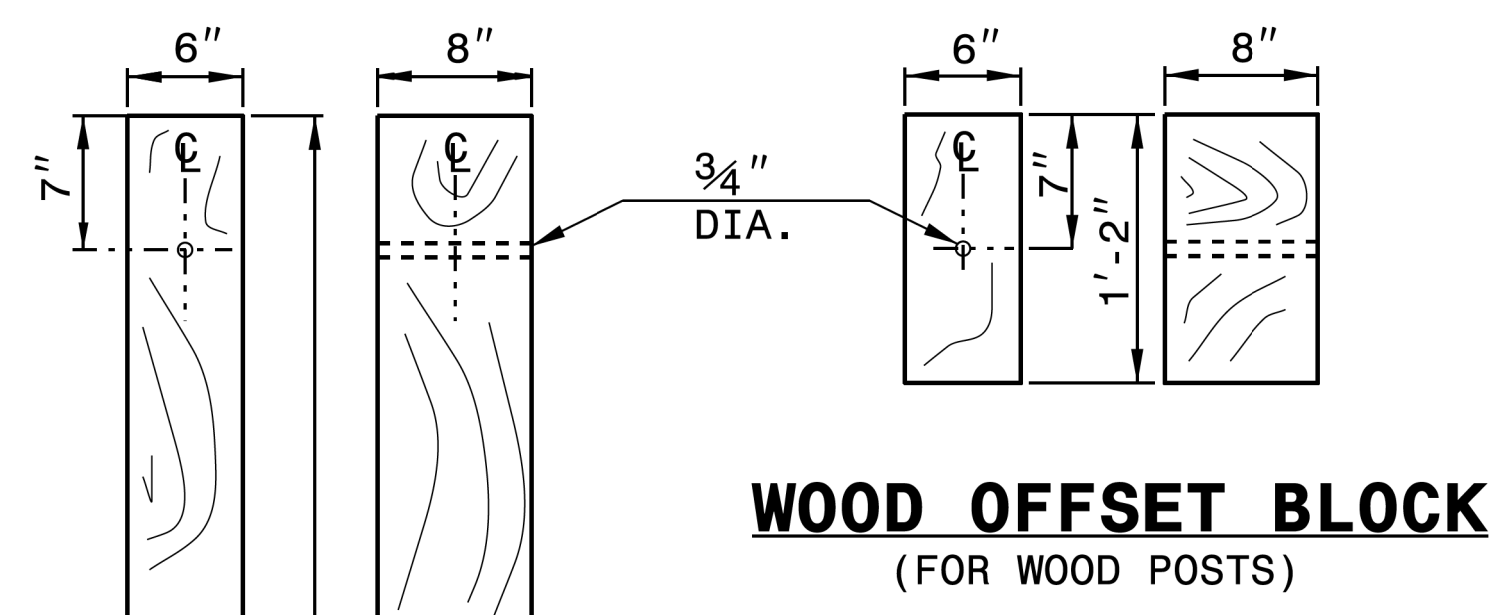

**WOOD OFFSET BLOCK  
(FOR WOOD POSTS)**

**STANDARD  
LINE POST**

**SHORT WOOD  
BREAKAWAY POST**

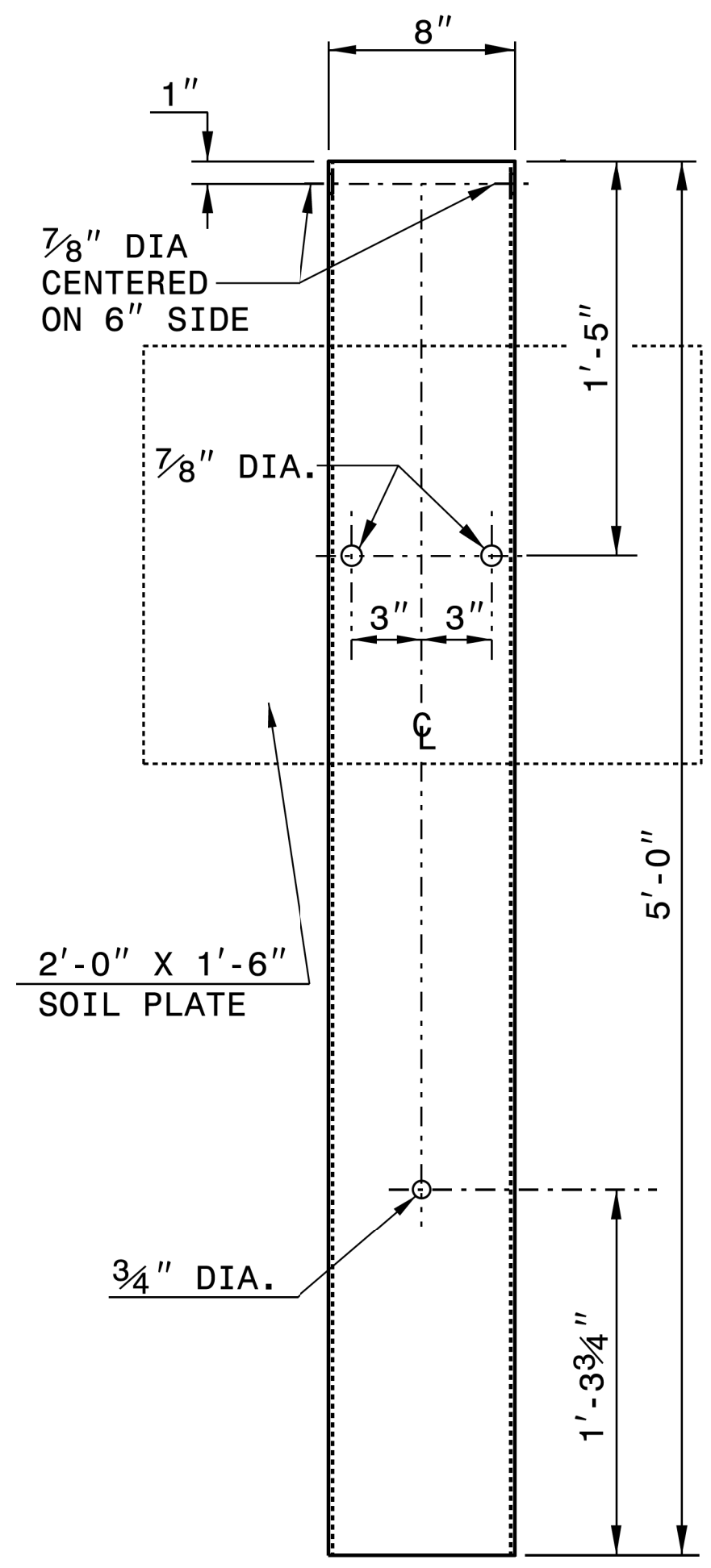

**STEEL TUBE  
TS 6"x8"x0.1875"**

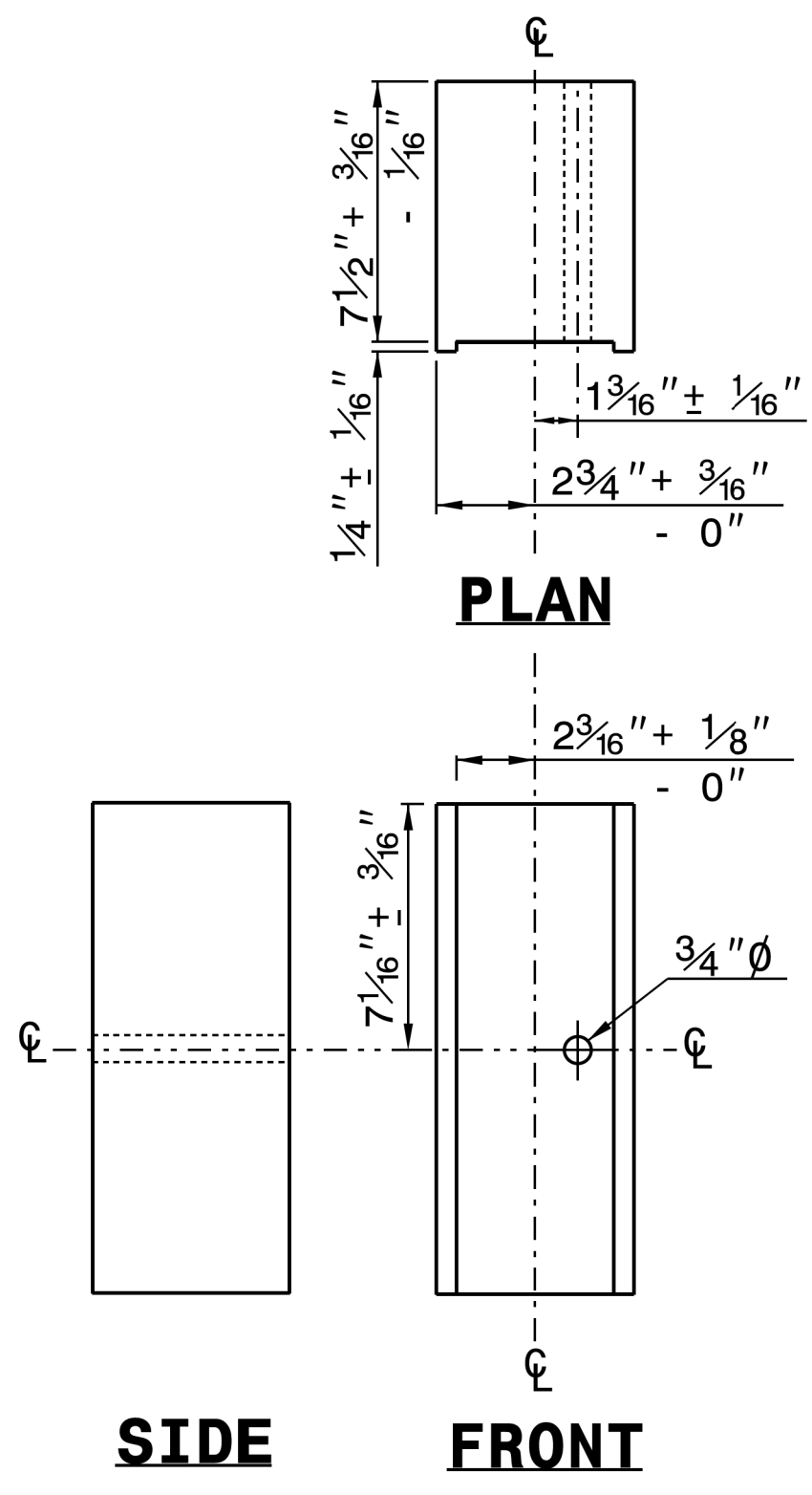

**PLAN**

**SIDE**

**FRONT**

**ROUTED  
OFFSET BLOCK**

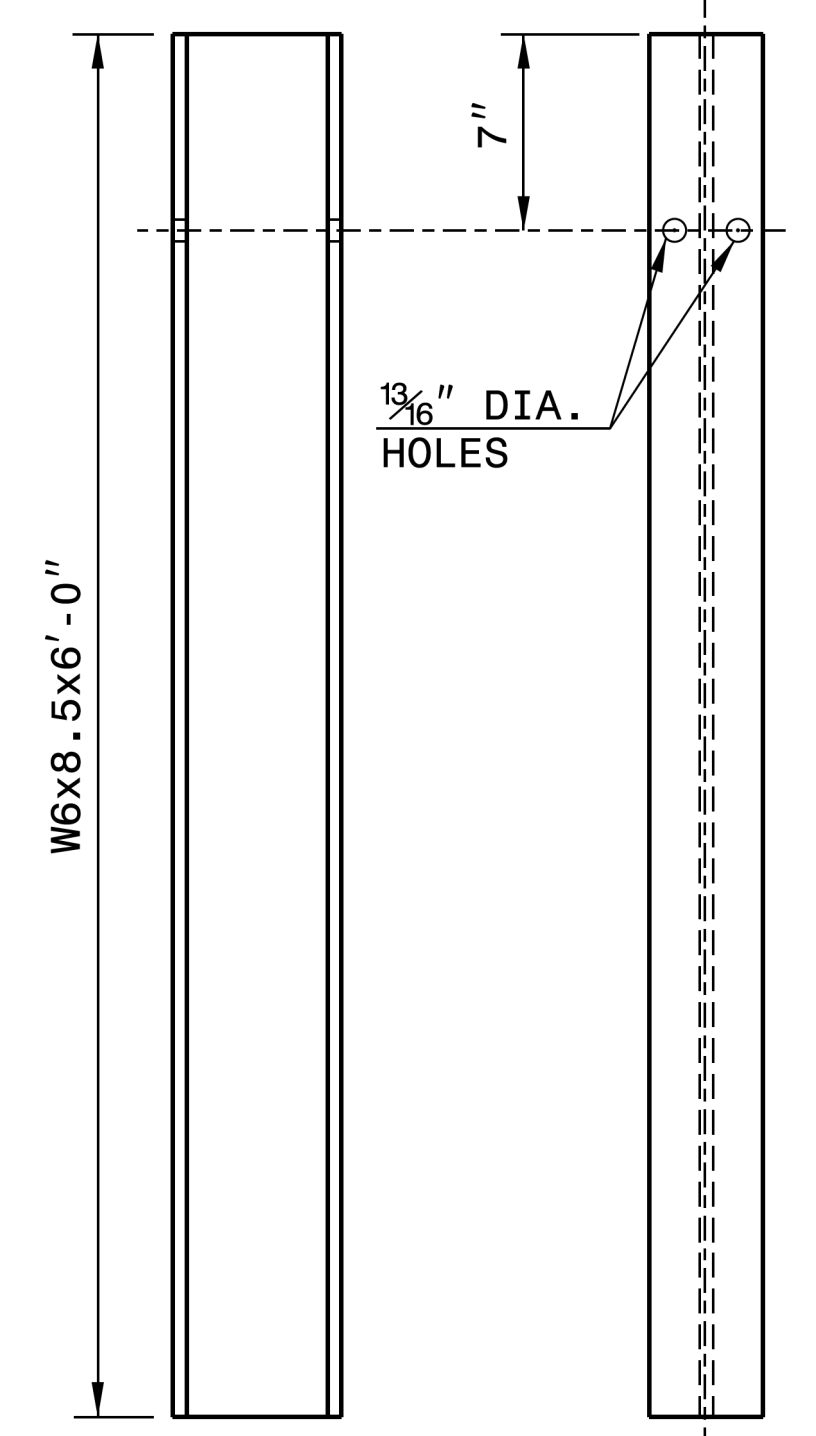

**SIDE**

**FRONT**

**"W6" STEEL POST**

**SYSTEM PARTS**

STATE OF NORTH CAROLINA  
DEPT. OF TRANSPORTATION  
DIVISION OF HIGHWAYS  
RALEIGH, N.C.

ROADWAY DETAIL DRAWING FOR  
**GUARDRAIL INSTALLATION**

SHEET 6 OF 8  
**862D02**

6/15/2021



DocuSigned by:  
*J. Howerton*  
873F3D77DCD48F...

**CONTRACTS STANDARDS  
AND DEVELOPMENT UNIT**  
Office 919-707-6950 FAX 919-250-4119

**SEE TITLE BLOCK**

ORIGINAL BY: J. HOWERTON DATE: 3-7-2018  
MODIFIED BY: DATE: \_\_\_\_\_  
CHECKED BY: DATE: \_\_\_\_\_  
FILE SPEC.: \_\_\_\_\_

STATE OF NORTH CAROLINA  
DEPT. OF TRANSPORTATION  
DIVISION OF HIGHWAYS  
RALEIGH, N.C.

ROADWAY DETAIL DRAWING FOR  
**CABLE GUIDERAIL**  
MEDIAN HAZARD GUIDERAIL LAYOUT

SHEET 1 OF 12  
**865D01**

STATE OF NORTH CAROLINA  
DEPT. OF TRANSPORTATION  
DIVISION OF HIGHWAYS  
RALEIGH, N.C.

ROADWAY DETAIL DRAWING FOR  
**CABLE GUIDERAIL**  
MEDIAN HAZARD GUIDERAIL LAYOUT

SHEET 1 OF 12  
**865D01**

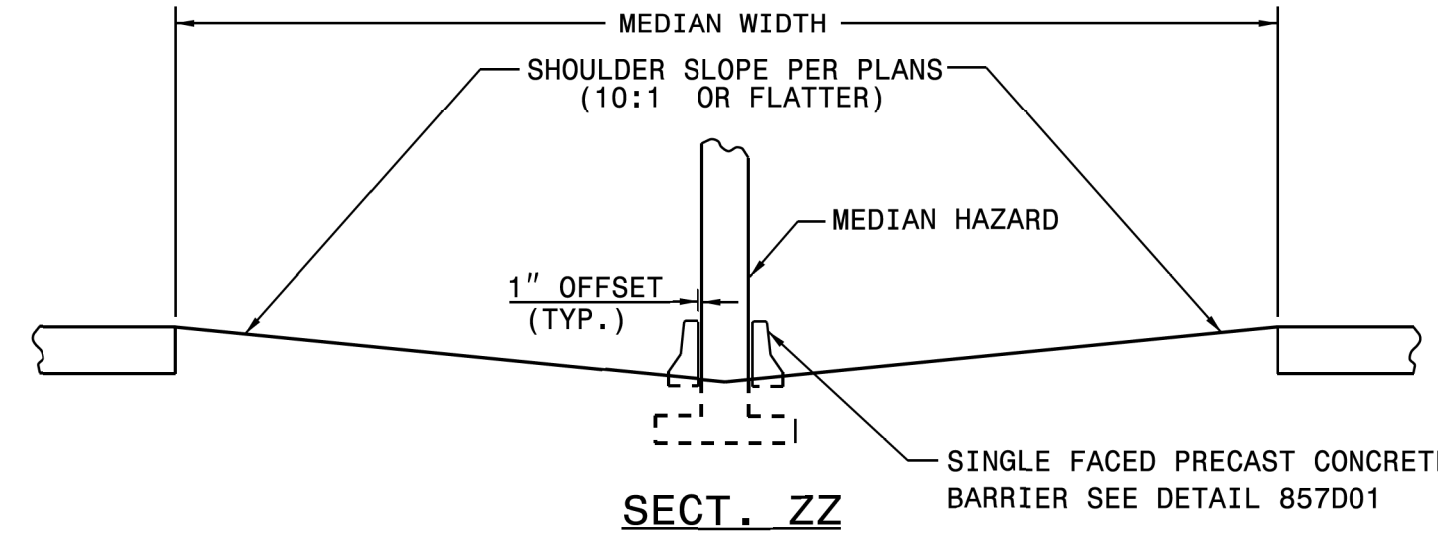
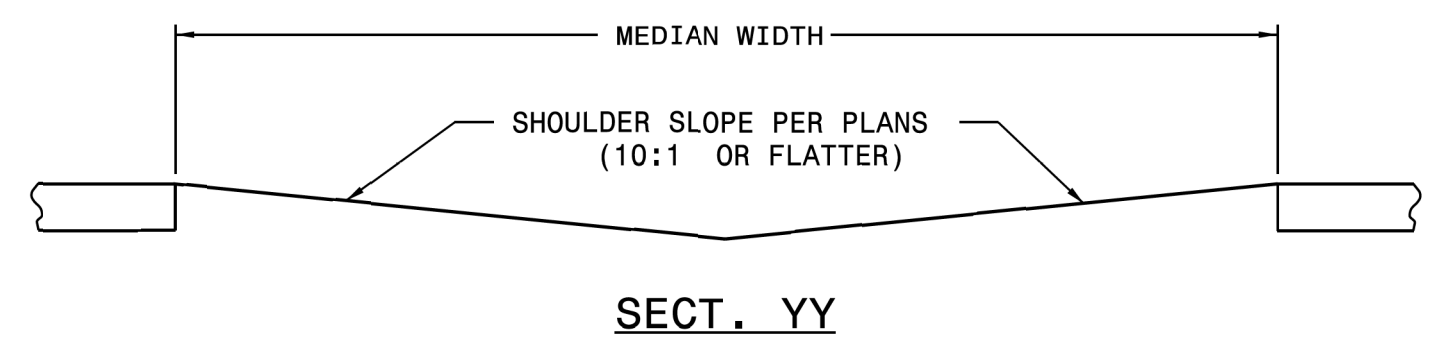
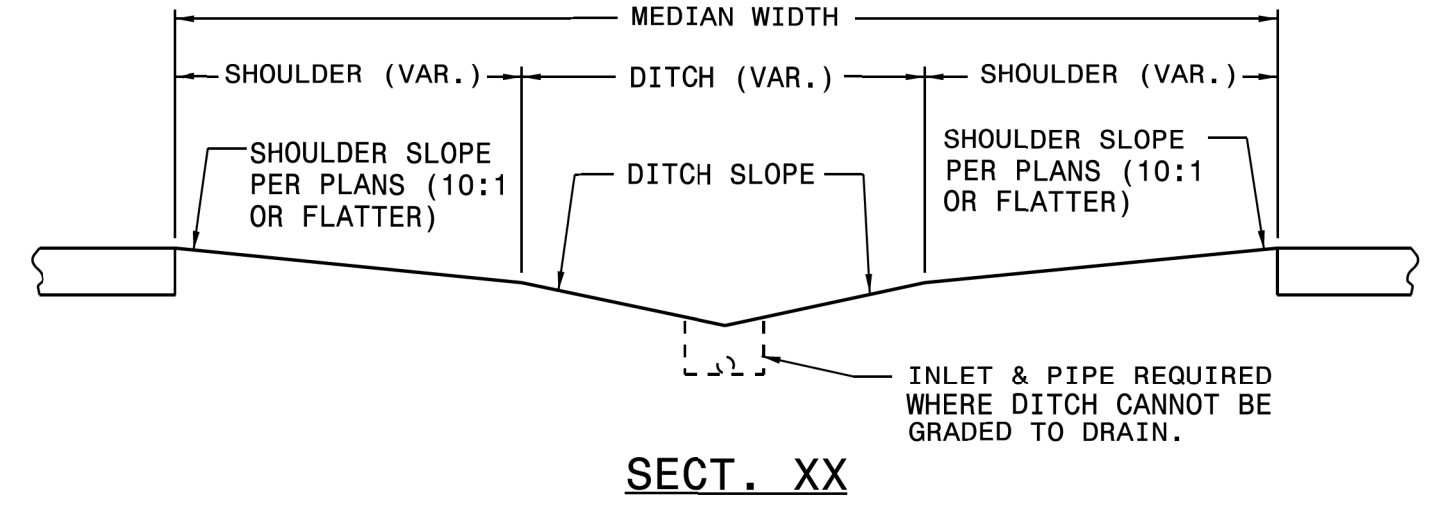
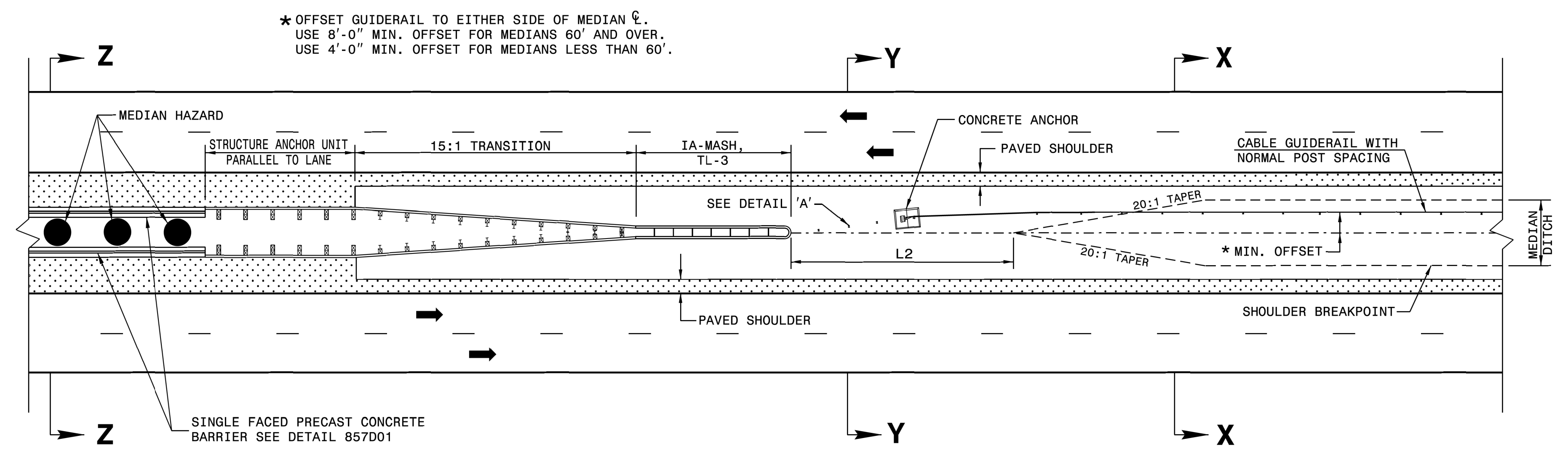

LIMITS OF -L2-	
MEDIAN WIDTH	-L2- DIMENSION
30'	80.0'
36'	60.0'
40' & ABOVE	40.0'

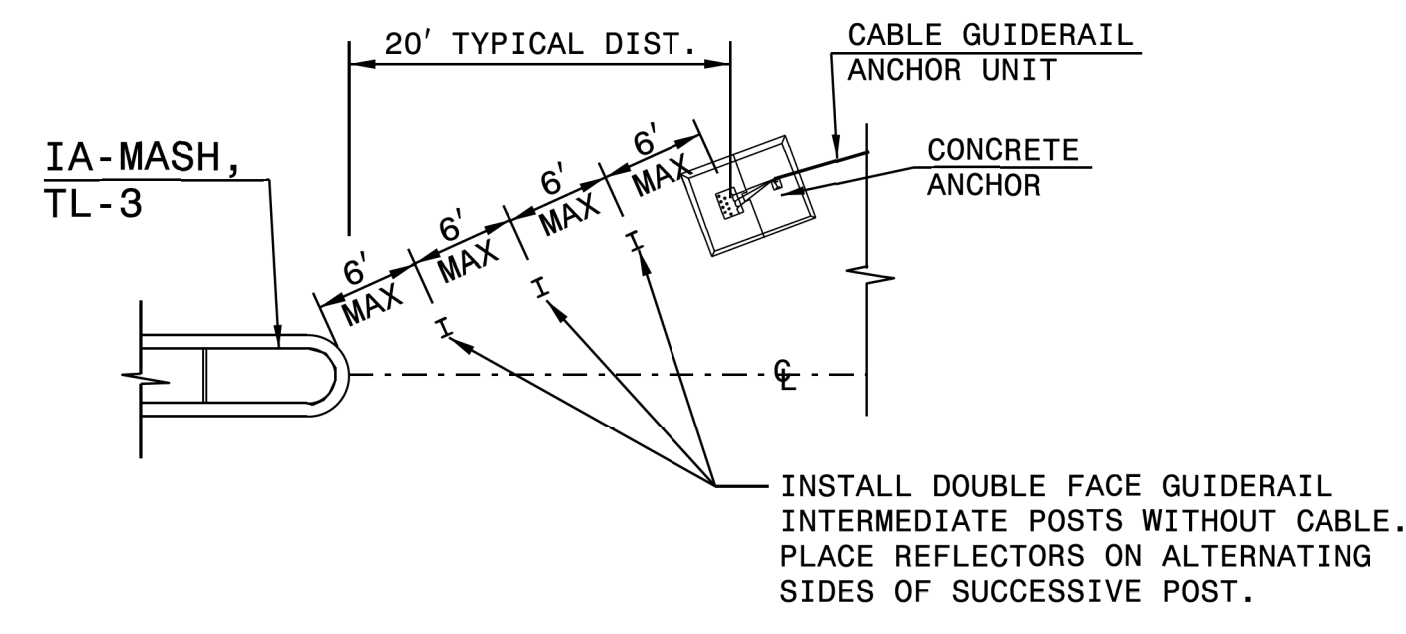

NOTE: POSTS WILL ONLY BE PLACED IN ONE OF THE TWO OPENINGS AT EACH MEDIAN HAZARD UNLESS OTHERWISE DIRECTED BY THE ENGINEER.

**DETAIL 'A'**

**DETAIL OF TREATMENT AT MEDIAN HAZARDS**

31-JAN-2019 10:43 S:\Contracts\Projects\865D01\Drawings\Standard Drawings\Details in Lieu of Standards\Division 8\865D01 Impact Attenuator-Sheet 1.dgn Jhowerton HT CS0-2/2/19

6/15/2021



DocuSigned by:  
J. S. Howerton  
073F3D170C0C45E

DOCUMENT NOT CONSIDERED FINAL  
UNLESS ALL SIGNATURES COMPLETED

**CONTRACT STANDARDS AND DEVELOPMENT UNIT**  
Office 919-707-6950 FAX 919-250-4119

**SEE TITLE BLOCK**

ORIGINAL BY: J. HOWERTON DATE: 08-23-18  
MODIFIED BY: DATE: \_\_\_\_\_  
CHECKED BY: DATE: \_\_\_\_\_  
FILE SPEC.: \_\_\_\_\_



STATE OF  
NORTH CAROLINA  
DEPT. OF TRANSPORTATION  
DIVISION OF HIGHWAYS  
RALEIGH, N.C.

ROADWAY DETAIL DRAWING FOR  
**GUARDRAIL INSTALLATION**

SHEET OF

STATE OF  
NORTH CAROLINA  
DEPT. OF TRANSPORTATION  
DIVISION OF HIGHWAYS  
RALEIGH, N.C.

ROADWAY DETAIL DRAWING FOR  
**GUARDRAIL INSTALLATION**

SHEET OF

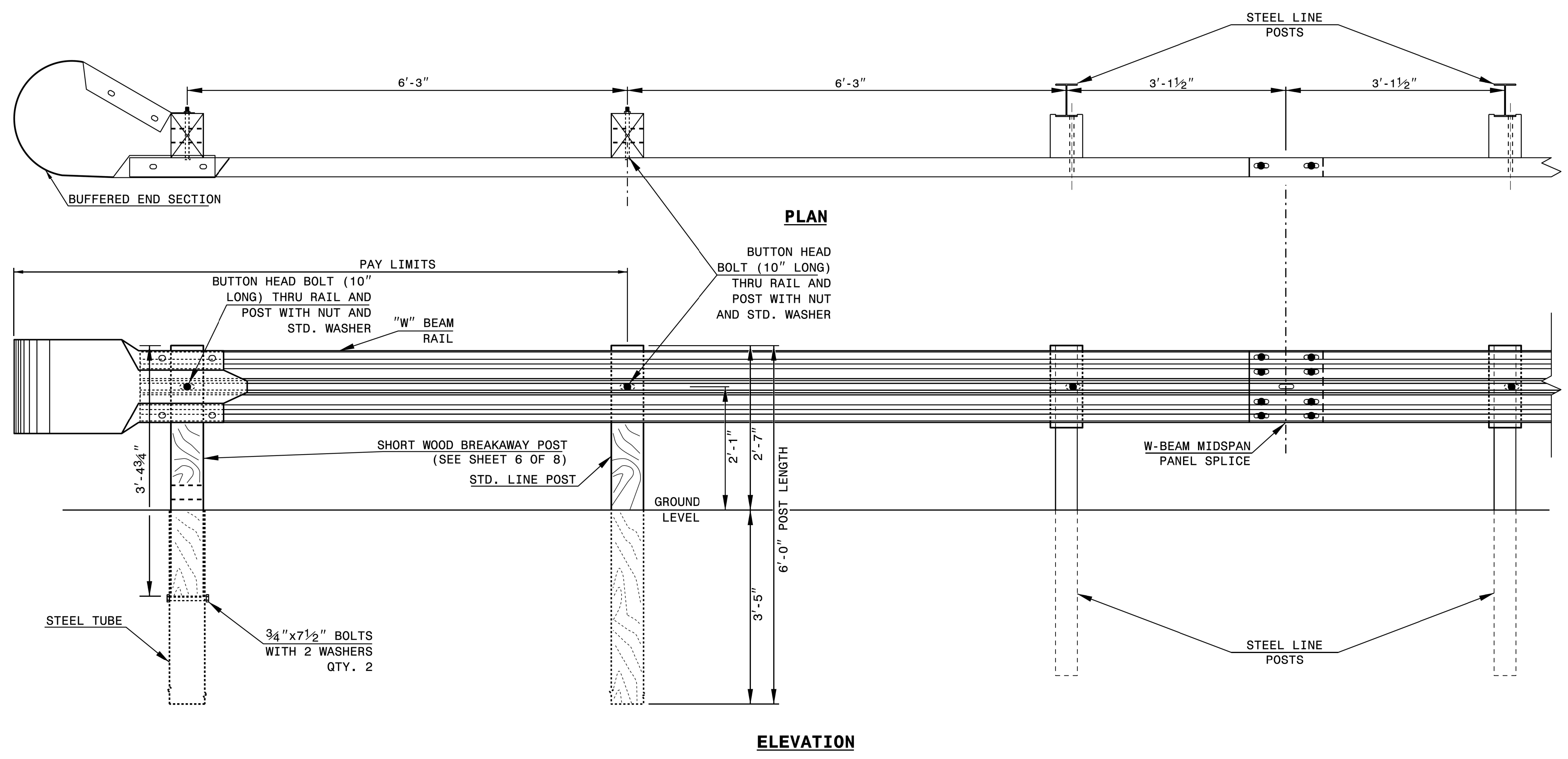

**TRAILING END UNIT ASSEMBLY**  
**A.T. - 1 SYSTEM**

6/15/2021



DocuSigned by:  
Joel S. Howerton  
473F3D17DC045F...

DOCUMENT NOT CONSIDERED FINAL  
UNLESS ALL SIGNATURES COMPLETED

<b>CONTRACTS STANDARDS AND DEVELOPMENT UNIT</b>	
Office 919-707-6950 FAX 919-250-4119	
<b>A.T. - 1 SYSTEM</b>	
ORIGINAL BY: _____	DATE: _____
MODIFIED BY: _____	DATE: _____
CHECKED BY: _____	DATE: _____
FILE SPEC.: _____	