

PLOT DRIVER: NCDOT... PENTABLE: NCDOT STRUCTURES DEFAULT PEN.tbl  
USER: PPETERSO DATE: 10/14/2021 TIME: 3:59:46 PM  
FILE: ... \SUPERS

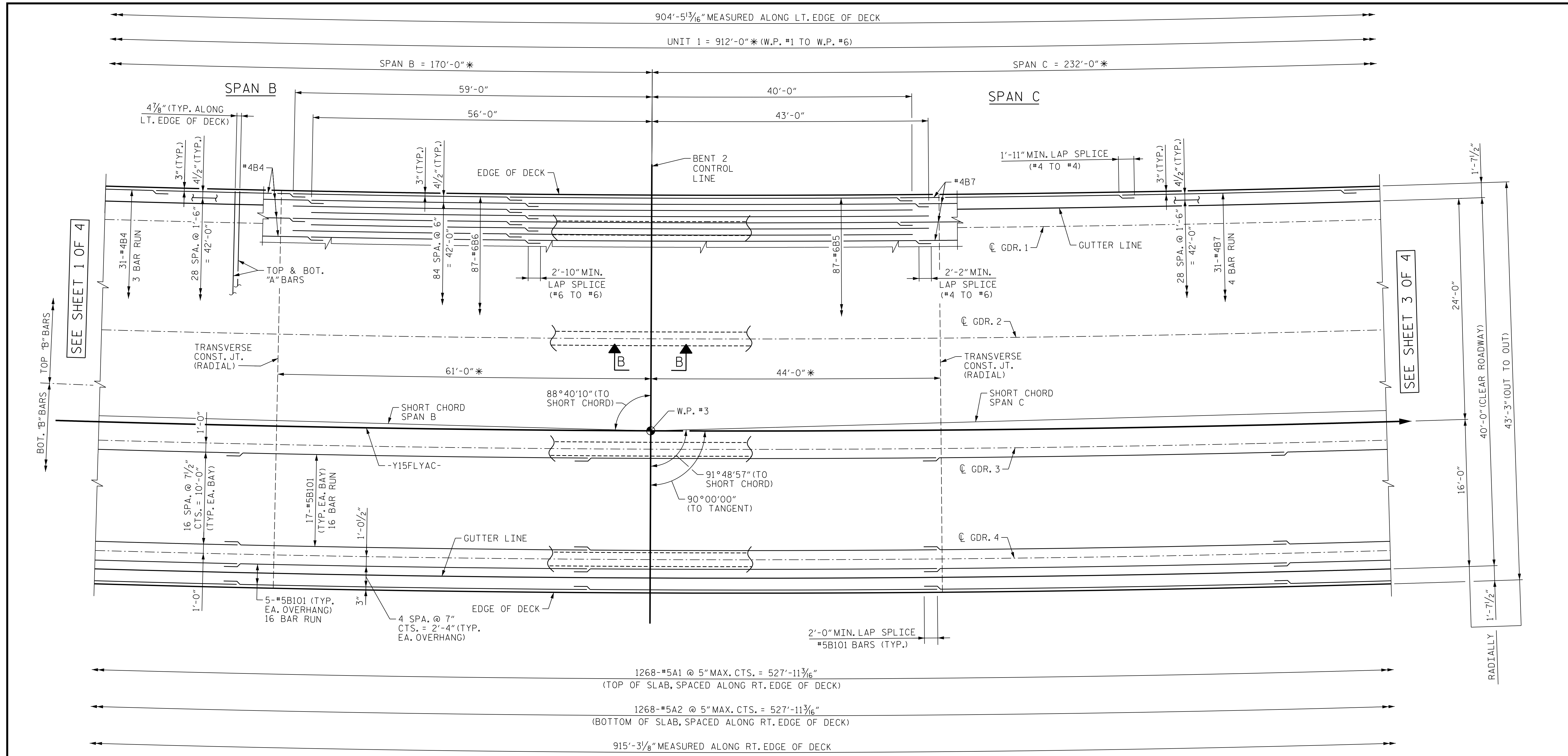

### PARTIAL PLAN OF SPANS - UNIT 1

\* = DIMENSIONS MEASURED ALONG -Y15FLYAC-

- NOTES**
- FOR SECTION B-B, SEE "SUPERSTRUCTURE TYPICAL SECTION" SHEET 2 OF 2.
  - SEE "SUPERSTRUCTURE PLAN OF SPANS ARC OFFSETS" SHEET 1 OF 4 FOR OUTSIDE EDGE OF DECK CURVE OFFSETS.
  - FOR REINFORCING STEEL IN CONCRETE BARRIER RAIL, SEE "SUPERSTRUCTURE CONCRETE BARRIER RAIL" SHEETS.
  - #5 "A" BARS ARE TO BE PLACED RADIALLY SPACED AT 5" MAX. CTS. ALONG RIGHT OUTSIDE EDGE OF SUPERSTRUCTURE.
  - FOR DECK POURING SEQUENCE, SEE "SUPERSTRUCTURE BILL OF MATERIAL" SHEET.
  - FOR TRANSVERSE CONST. JT. DETAIL, SEE SHEET 1 OF 4.



PROJECT NO. U-2579AB  
 FORSYTH COUNTY  
 STATION: 60+66.06 -Y15FLYAC-  
 SHEET 2 OF 4

STATE OF NORTH CAROLINA  
 DEPARTMENT OF TRANSPORTATION  
 RALEIGH

**SUPERSTRUCTURE PLAN OF SPANS UNIT 1**

REVISIONS					
NO.	BY:	DATE:	NO.	BY:	DATE:
1	--	--	3	--	--
2	--	--	4	--	--

SHEET NO. S04-021  
 TOTAL SHEETS 144

DES BY: <u>G. SCHMITZ</u>	DATE: <u>06/19</u>	DWG BY: <u>B. PETERSON</u>	DATE: <u>07/19</u>
DES CHK: <u>D. COLETTI</u>	DATE: <u>06/19</u>	CHK BY: <u>G. SCHMITZ</u>	DATE: <u>11/19</u>

**HDR** HDR Engineering, Inc. of the Carolinas  
 555 Fayetteville St., Suite 900 Raleigh, N.C. 27601  
 N.C.B.E.L.S. License Number: F-0116

DOCUMENT NOT CONSIDERED FINAL  
 UNLESS ALL SIGNATURES COMPLETED

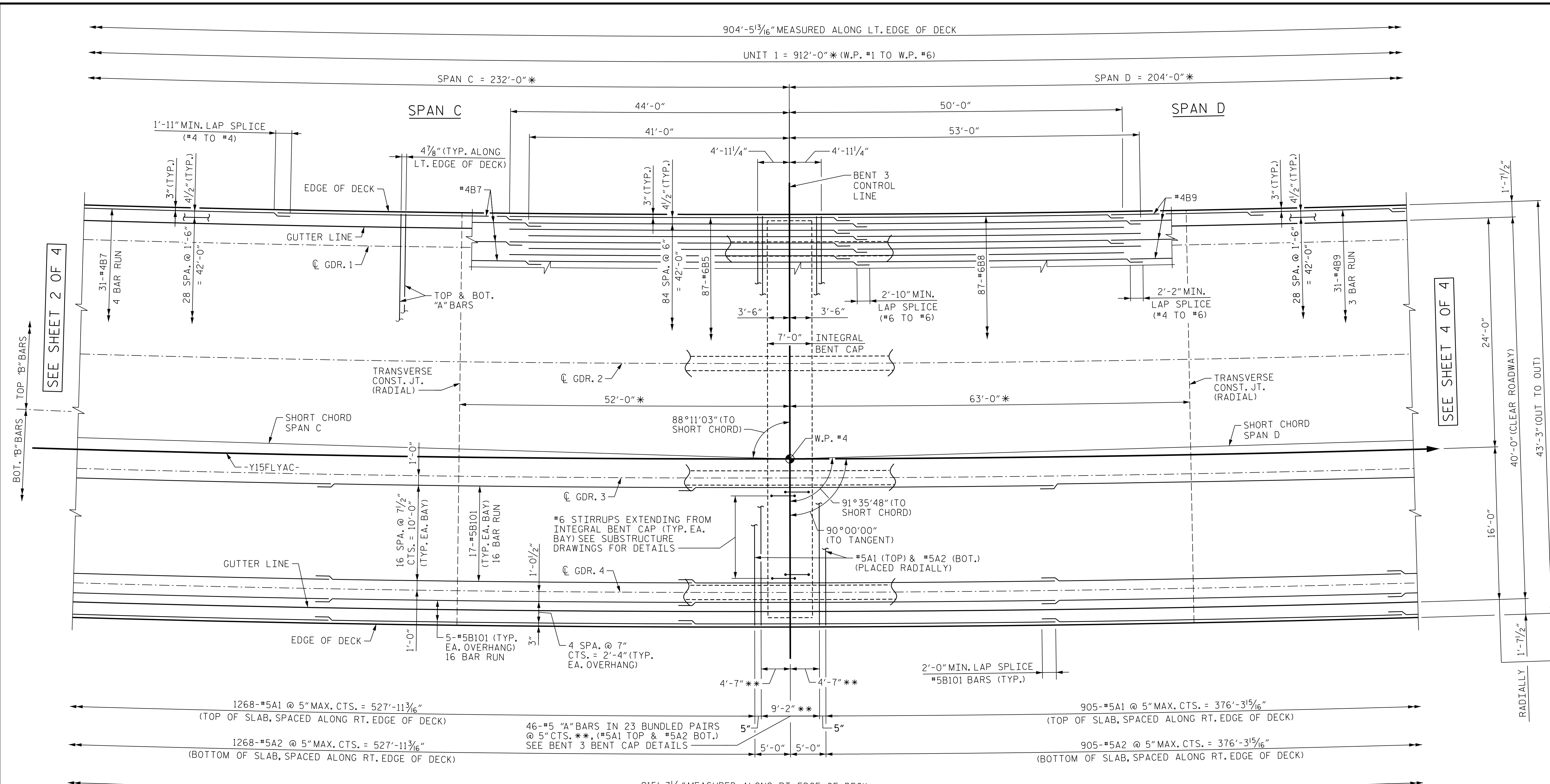

PARTIAL PLAN OF SPANS - UNIT 1

\* = DIMENSIONS MEASURED ALONG -Y15FLYAC-  
 \*\* = PARALLEL TO BENT

**NOTES**  
 SEE "SUPERSTRUCTURE PLAN OF SPANS ARC OFFSETS" SHEET 1 OF 4 FOR OUTSIDE EDGE OF DECK CURVE OFFSETS.  
 FOR REINFORCING STEEL IN CONCRETE BARRIER RAIL, SEE "SUPERSTRUCTURE CONCRETE BARRIER RAIL" SHEETS.  
 #5 "A" BARS ARE TO BE PLACED RADIALLY SPACED AT 5" MAX. CTS. ALONG RIGHT OUTSIDE EDGE OF SUPERSTRUCTURE.  
 FOR DECK POURING SEQUENCE, SEE "SUPERSTRUCTURE BILL OF MATERIAL" SHEET.  
 FOR TRANSVERSE CONST. JT. DETAIL, SEE SHEET 1 OF 4.



PROJECT NO. U-2579AB  
 FORSYTH COUNTY  
 STATION: 60+66.06 -Y15FLYAC-  
 SHEET 3 OF 4

STATE OF NORTH CAROLINA  
 DEPARTMENT OF TRANSPORTATION  
 RALEIGH

**SUPERSTRUCTURE PLAN OF SPANS UNIT 1**

REVISIONS					
NO.	BY:	DATE:	NO.	BY:	DATE:
1	--	--	3	--	--
2	--	--	4	--	--

SHEET NO. S04-022  
 TOTAL SHEETS 144

PLOT DRIVER: NCDOT.pdf\_color\_eng-50.ppt  
 USER: PPETERSO DATE: 10/14/2021  
 FILE: ... \SUPERS

DES BY: G. SCHMITZ DATE: 06/19  
 DES CHK: D. COLETTI DATE: 06/19  
 DWG BY: B. PETERSON DATE: 07/19  
 CHK BY: G. SCHMITZ DATE: 11/19

**HDR** HDR Engineering, Inc. of the Carolinas  
 555 Fayetteville St., Suite 900 Raleigh, N.C. 27601  
 N.C.B.E.L.S. License Number: F-0116

DOCUMENT NOT CONSIDERED FINAL  
 UNLESS ALL SIGNATURES COMPLETED

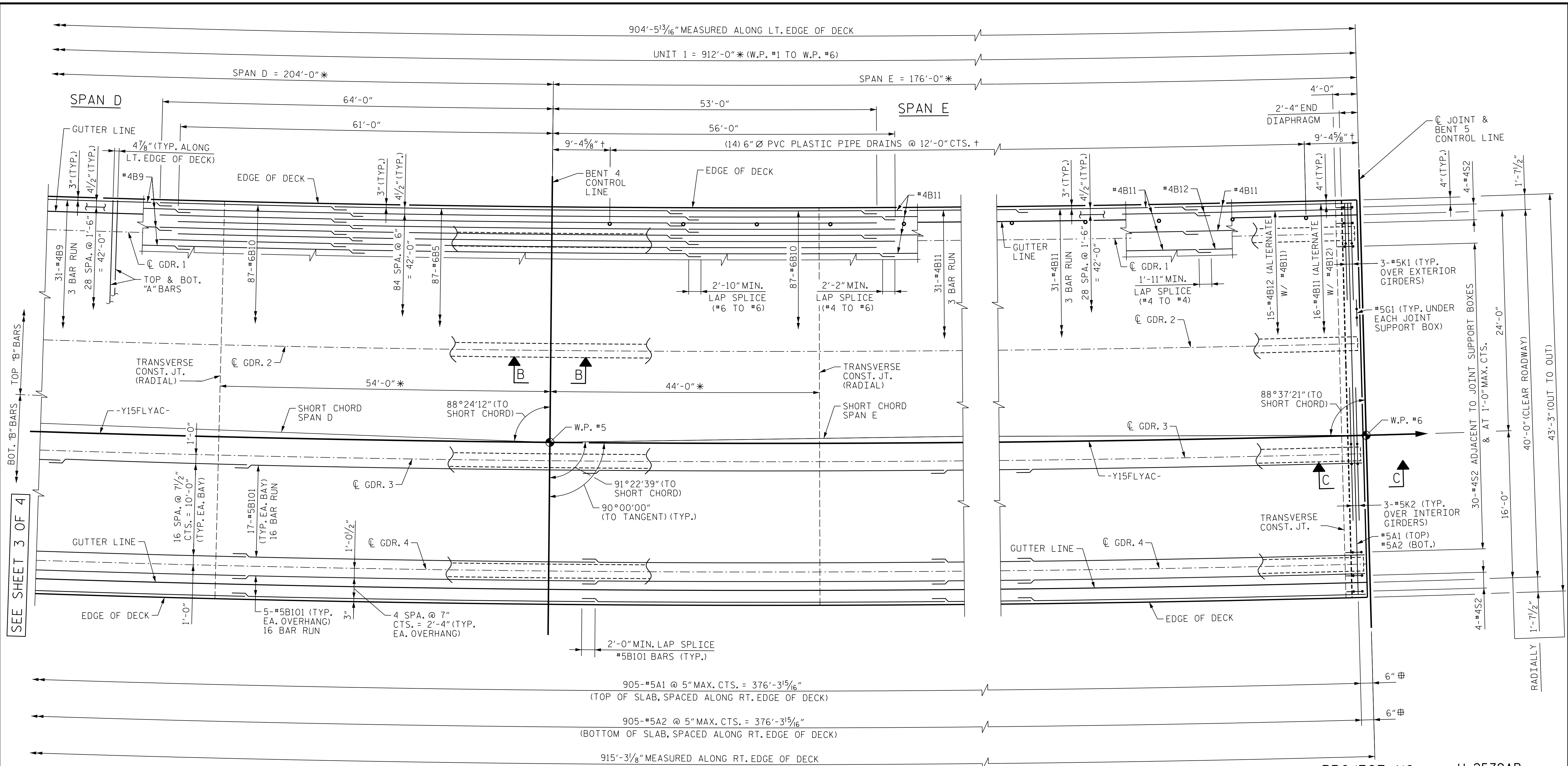

**PARTIAL PLAN OF SPANS - UNIT 1**

- \* = DIMENSIONS MEASURED ALONG -Y15FLYAC-
- # = ADJUST AS REQUIRED TO CLEAR MODULAR EXPANSION JOINT ASSEMBLY
- + = DIMENSIONS MEASURED ALONG LEFT EDGE OF DECK

**NOTES**

FOR SECTIONS B-B AND C-C, SEE "SUPERSTRUCTURE TYPICAL SECTION" SHEETS.

SEE "SUPERSTRUCTURE PLAN OF SPANS ARC OFFSETS" SHEETS 1 OF 4 AND 2 OF 4 FOR OUTSIDE EDGE OF DECK CURVE OFFSETS.

FOR REINFORCING STEEL IN CONCRETE BARRIER RAIL, SEE "SUPERSTRUCTURE CONCRETE BARRIER RAIL" SHEETS.

#5 "A" BARS ARE TO BE PLACED RADIALLY SPACED AT 5" MAX. CTS. ALONG RIGHT OUTSIDE EDGE OF SUPERSTRUCTURE.

FOR DECK POURING SEQUENCE, SEE "SUPERSTRUCTURE BILL OF MATERIAL" SHEET.

FOR TRANSVERSE CONST. JT. DETAIL, SEE SHEET 1 OF 4.



PROJECT NO. U-2579AB  
 FORSYTH COUNTY  
 STATION: 60+66.06 -Y15FLYAC-  
 SHEET 4 OF 4

STATE OF NORTH CAROLINA  
 DEPARTMENT OF TRANSPORTATION  
 RALEIGH

**SUPERSTRUCTURE PLAN OF SPANS UNIT 1**

REVISIONS					
NO.	BY:	DATE:	NO.	BY:	DATE:
1	--	--	3	--	--
2	--	--	4	--	--

SHEET NO. S04-023  
 TOTAL SHEETS 144

PLOT DRIVER: NCDOT.pdf\_color\_eng-50.ppt  
 USER: PPRETERSO      DATE: 10/14/2021  
 TIME: 3:59:49 PM  
 FILE: ... \SUPERS

DES BY: <u>G. SCHMITZ</u>	DATE: <u>06/19</u>	DWG BY: <u>B. PETERSON</u>	DATE: <u>07/19</u>
DES CHK: <u>D. COLETTI</u>	DATE: <u>06/19</u>	CHK BY: <u>G. SCHMITZ</u>	DATE: <u>11/19</u>

**HDR** Engineering, Inc. of the Carolinas  
 555 Fayetteville St., Suite 900 Raleigh, N.C. 27601  
 N.C.B.E.L.S. License Number: F-0116

10/15/2021  
 DOCUMENT NOT CONSIDERED FINAL  
 UNLESS ALL SIGNATURES COMPLETED

PLOT DRIVER: NCDOT... PENTABLE: NCDOT... USER: PPETERSO... DATE: 10/14/2021... FILE: ... \SUPERS

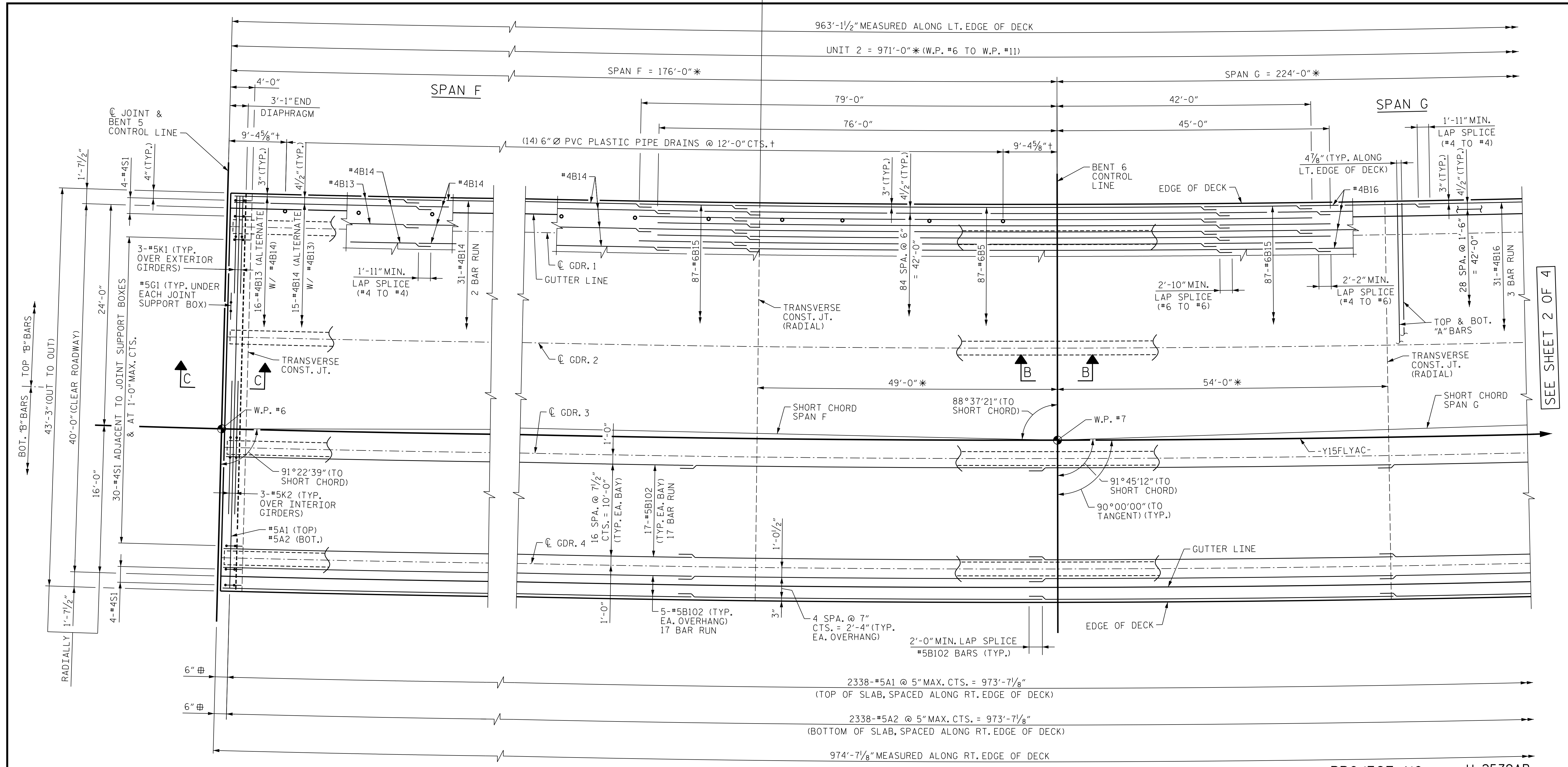

PARTIAL PLAN OF SPANS - UNIT 2

- \* = DIMENSIONS MEASURED ALONG -Y15FLYAC-
# = ADJUST AS REQUIRED TO CLEAR MODULAR EXPANSION JOINT ASSEMBLY
+ = DIMENSIONS MEASURED ALONG LEFT EDGE OF DECK

NOTES
FOR SECTIONS B-B AND C-C, SEE "SUPERSTRUCTURE TYPICAL SECTION" SHEETS.
SEE "SUPERSTRUCTURE PLAN OF SPANS ARC OFFSETS" SHEETS 2 OF 4 AND 3 OF 4 FOR OUTSIDE EDGE OF DECK CURVE OFFSETS.
FOR REINFORCING STEEL IN CONCRETE BARRIER RAIL, SEE "SUPERSTRUCTURE CONCRETE BARRIER RAIL" SHEETS.
#5 "A" BARS ARE TO BE PLACED RADIALLY SPACED AT 5" MAX. CTS. ALONG RIGHT OUTSIDE EDGE OF SUPERSTRUCTURE.
FOR DECK POURING SEQUENCE, SEE "SUPERSTRUCTURE BILL OF MATERIAL" SHEET.
FOR TRANSVERSE CONST. JT. DETAIL, SEE "PLAN OF SPANS - UNIT 1" SHEET 1 OF 4.



PROJECT NO. U-2579AB
FORSYTH COUNTY
STATION: 60+66.06 -Y15FLYAC-
SHEET 1 OF 4

DEPARTMENT OF TRANSPORTATION
RALEIGH
SUPERSTRUCTURE PLAN OF SPANS UNIT 2
REVISIONS table with columns for NO., BY, DATE, and SHEET NO.

Table with columns for DES BY, DATE, DWG BY, DATE, CHK BY, DATE. Includes names like T. ANDREWS, B. PETERSON, D. OLDS, G. SCHMITZ.

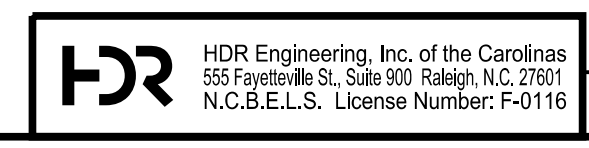

10/15/2021
DOCUMENT NOT CONSIDERED FINAL UNLESS ALL SIGNATURES COMPLETED

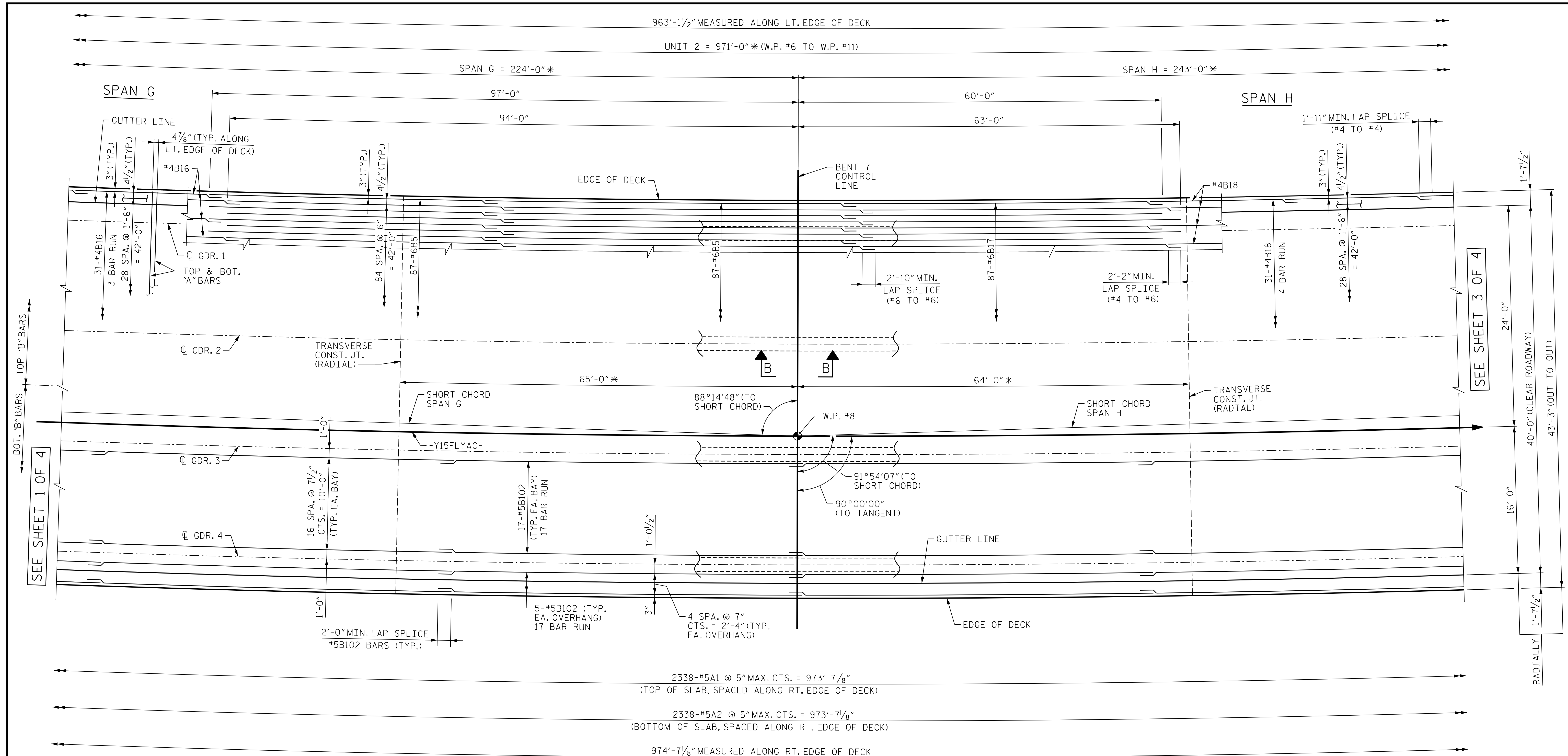

### PARTIAL PLAN OF SPANS - UNIT 2

\* = DIMENSIONS MEASURED ALONG -Y15FLYAC-

#### NOTES

- FOR SECTION B-B, SEE "SUPERSTRUCTURE TYPICAL SECTION" SHEET 2 OF 2.
- SEE "SUPERSTRUCTURE PLAN OF SPANS ARC OFFSETS" SHEET 3 OF 4 FOR OUTSIDE EDGE OF DECK CURVE OFFSETS.
- FOR REINFORCING STEEL IN CONCRETE BARRIER RAIL, SEE "SUPERSTRUCTURE CONCRETE BARRIER RAIL" SHEETS.
- #5 "A" BARS ARE TO BE PLACED RADIALLY SPACED AT 5" MAX. C.T.S. ALONG RIGHT OUTSIDE EDGE OF SUPERSTRUCTURE.
- FOR DECK POURING SEQUENCE, SEE "SUPERSTRUCTURE BILL OF MATERIAL" SHEET.
- FOR TRANSVERSE CONST. JT. DETAIL, SEE "PLAN OF SPANS - UNIT 1" SHEET 1 OF 4.



10/15/2021

PROJECT NO. U-2579AB  
 FORSYTH COUNTY  
 STATION: 60+66.06 -Y15FLYAC-  
 SHEET 2 OF 4

STATE OF NORTH CAROLINA  
 DEPARTMENT OF TRANSPORTATION  
 RALEIGH

## SUPERSTRUCTURE PLAN OF SPANS UNIT 2

REVISIONS					
NO.	BY:	DATE:	NO.	BY:	DATE:
1	--	--	3	--	--
2	--	--	4	--	--

SHEET NO. S04-025  
 TOTAL SHEETS 144

PLOT DRIVER: NCDOT...  
 USER: PETERSON  
 DATE: 10/14/2021

DES BY: T. ANDREWS	DATE: 06/19	DWG BY: B. PETERSON	DATE: 07/19
DES CHK: D. OLDS	DATE: 06/19	CHK BY: G. SCHMITZ	DATE: 11/19



DOCUMENT NOT CONSIDERED FINAL UNLESS ALL SIGNATURES COMPLETED

PLOT DRIVER: NCDOT.pdf\_color\_eng-50a.plt  
USER: PETERSON DATE: 10/14/2021  
TIME: 3:59:53 PM  
FILE: ... \ASUPERS

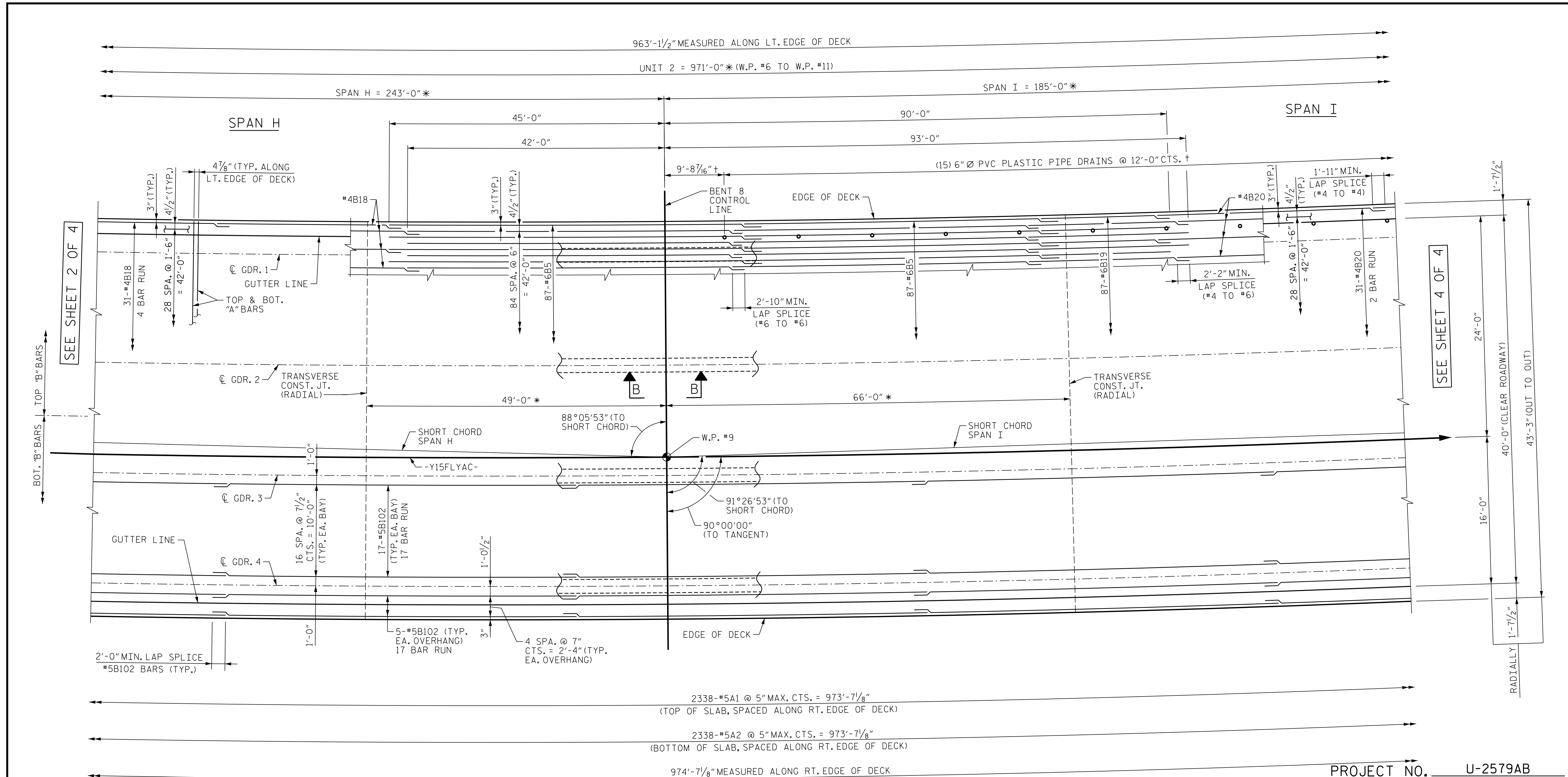

### PARTIAL PLAN OF SPANS - UNIT 2

\* = DIMENSIONS MEASURED ALONG -Y15FLYAC-  
+ = DIMENSIONS MEASURED ALONG LEFT EDGE OF DECK

**NOTES**  
FOR SECTION B-B, SEE "SUPERSTRUCTURE TYPICAL SECTION" SHEET 2 OF 2.  
SEE "SUPERSTRUCTURE PLAN OF SPANS ARC OFFSETS" SHEETS 3 OF 4 AND 4 OF 4 FOR OUTSIDE EDGE OF DECK CURVE OFFSETS.  
FOR REINFORCING STEEL IN CONCRETE BARRIER RAIL, SEE "SUPERSTRUCTURE CONCRETE BARRIER RAIL" SHEETS.  
#5 "A" BARS ARE TO BE PLACED RADIALLY SPACED AT 5" MAX. CTS. ALONG RIGHT OUTSIDE EDGE OF SUPERSTRUCTURE.  
FOR DECK POURING SEQUENCE, SEE "SUPERSTRUCTURE BILL OF MATERIAL" SHEET.  
FOR TRANSVERSE CONST. JT. DETAIL, SEE "PLAN OF SPANS - UNIT 1" SHEET 1 OF 4.

PROJECT NO. U-2579AB  
FORSYTH COUNTY  
STATION: 60+66.06 -Y15FLYAC-  
SHEET 3 OF 4



STATE OF NORTH CAROLINA  
DEPARTMENT OF TRANSPORTATION  
RALEIGH

## SUPERSTRUCTURE PLAN OF SPANS UNIT 2

REVISIONS					
NO.	BY:	DATE:	NO.	BY:	DATE:
1	--	--	3	--	--
2	--	--	4	--	--

SHEET NO. S04-026  
TOTAL SHEETS 144

**HDR** HDR Engineering, Inc. of the Carolinas  
555 Fayetteville St., Suite 900 Raleigh, N.C. 27601  
N.C.B.E.L.S. License Number: F-0116

DOCUMENT NOT CONSIDERED FINAL  
UNLESS ALL SIGNATURES COMPLETED

DES BY: T. ANDREWS	DATE: 06/19	DWG BY: B. PETERSON	DATE: 07/19
DES CHK: D. OLDS	DATE: 06/19	CHK BY: G. SCHMITZ	DATE: 11/19

PLOT DRIVER: NCDOT...  
 USER: PETERSON...  
 DATE: 10/14/2021...  
 TIME: 3:59:54 PM...  
 FILE: ...SUPERS

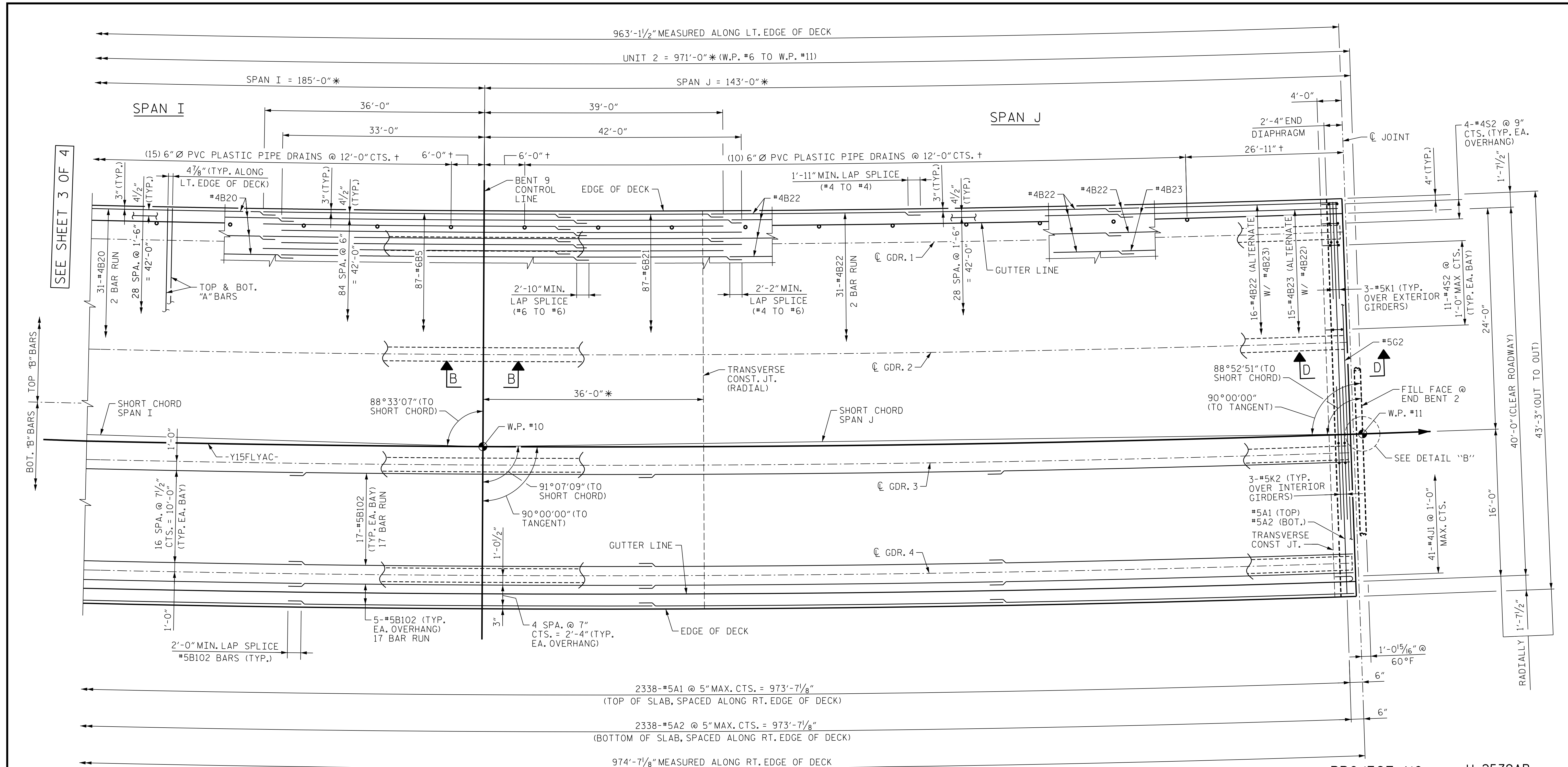

**PARTIAL PLAN OF SPANS - UNIT 2**

\* = DIMENSIONS MEASURED ALONG -Y15FLYAC-  
 + = DIMENSIONS MEASURED ALONG LEFT EDGE OF DECK

**NOTES**

FOR SECTIONS B-B AND D-D, SEE "SUPERSTRUCTURE TYPICAL SECTION" SHEET 1 OF 2.

SEE "SUPERSTRUCTURE PLAN OF SPANS ARC OFFSETS" SHEET 4 OF 4 FOR OUTSIDE EDGE OF DECK CURVE OFFSETS.

FOR REINFORCING STEEL IN CONCRETE BARRIER RAIL, SEE "SUPERSTRUCTURE CONCRETE BARRIER RAIL" SHEETS.

#5 "A" BARS ARE TO BE PLACED RADIALLY SPACED AT 5" MAX. CTS. ALONG RIGHT OUTSIDE EDGE OF SUPERSTRUCTURE.

FOR DECK POURING SEQUENCE, SEE "SUPERSTRUCTURE BILL OF MATERIAL" SHEET.

FOR TRANSVERSE CONST. JT. DETAIL, SEE "PLAN OF SPANS - UNIT 1" SHEET 1 OF 4.

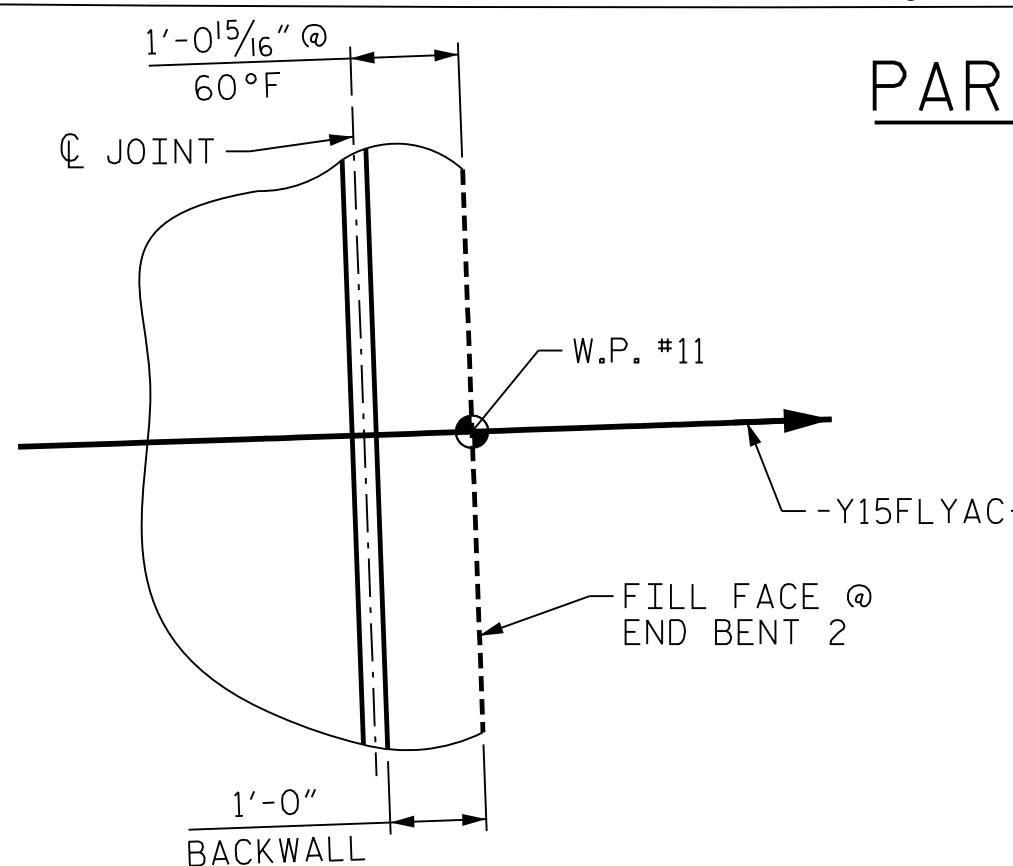

**DETAIL "B"**

PROJECT NO. U-2579AB  
 FORSYTH COUNTY  
 STATION: 60+66.06 -Y15FLYAC-  
 SHEET 4 OF 4

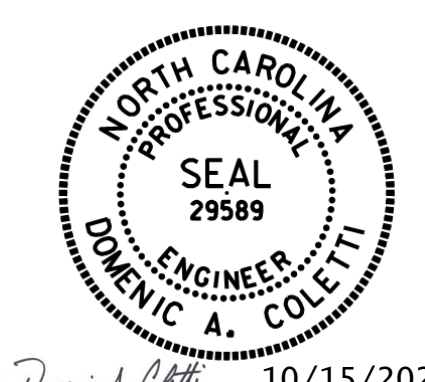

STATE OF NORTH CAROLINA  
DEPARTMENT OF TRANSPORTATION  
RALEIGH

**SUPERSTRUCTURE PLAN OF SPANS UNIT 2**

REVISIONS					
NO.	BY:	DATE:	NO.	BY:	DATE:
1	--	--	3	--	--
2	--	--	4	--	--

SHEET NO. S04-027  
 TOTAL SHEETS 144

DES BY: T. ANDREWS	DATE: 06/19	DWG BY: B. PETERSON	DATE: 07/19
DES CHK: D. OLDS	DATE: 06/19	CHK BY: G. SCHMITZ	DATE: 11/19

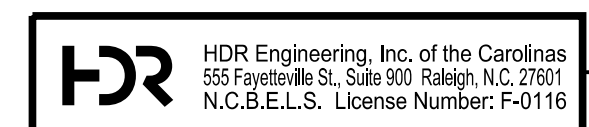

10/15/2021  
 DOCUMENT NOT CONSIDERED FINAL UNLESS ALL SIGNATURES COMPLETED

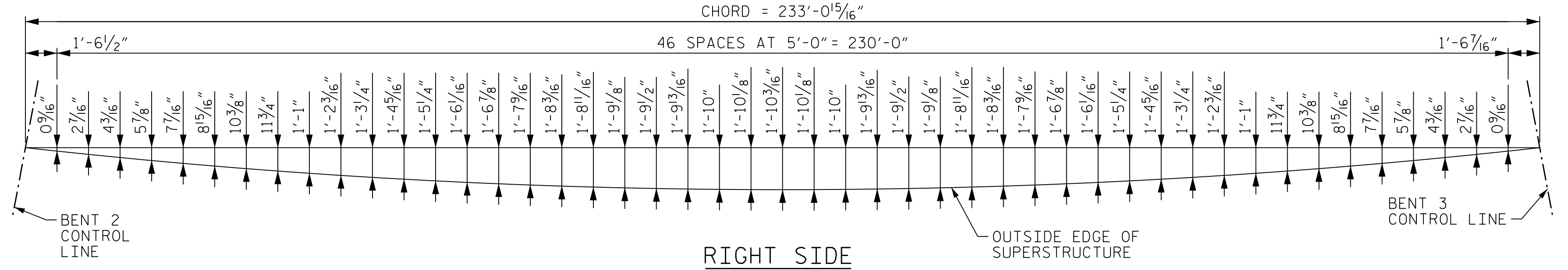
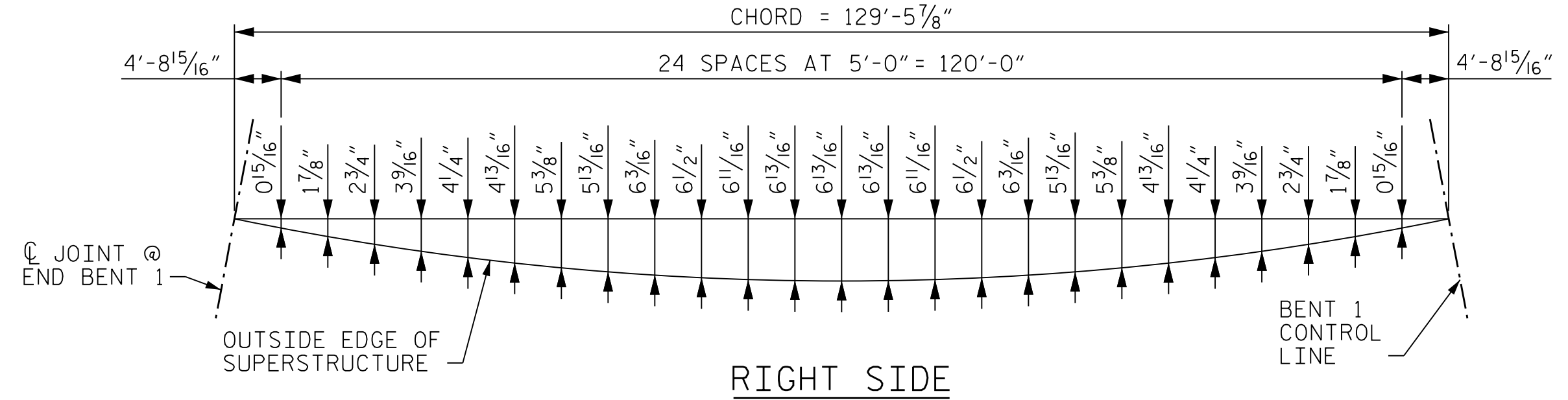
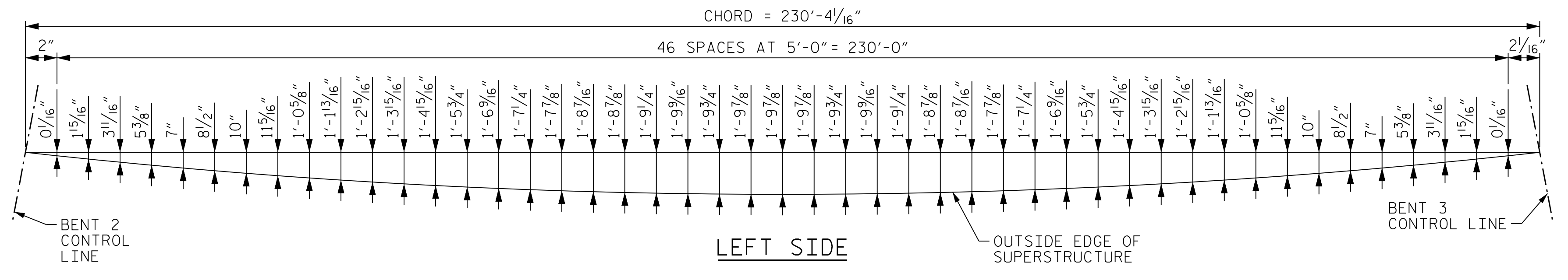
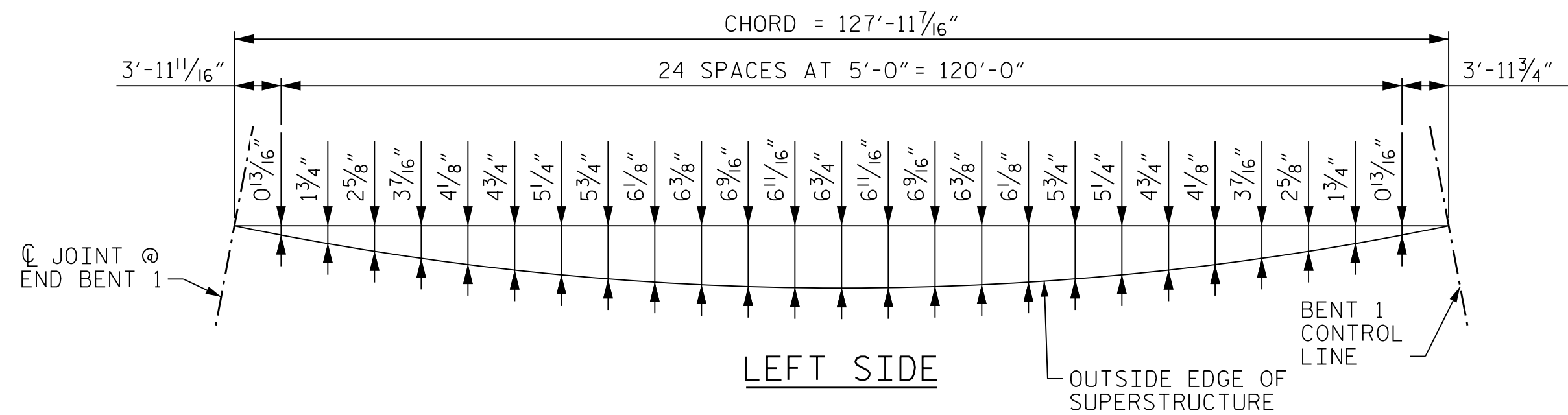

OUTSIDE EDGE ARC OFFSETS - SPAN A

OUTSIDE EDGE ARC OFFSETS - SPAN C

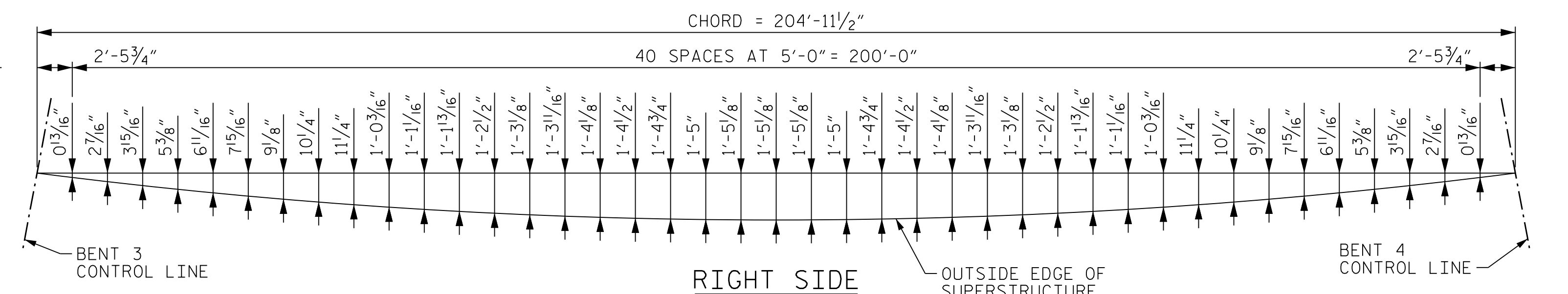
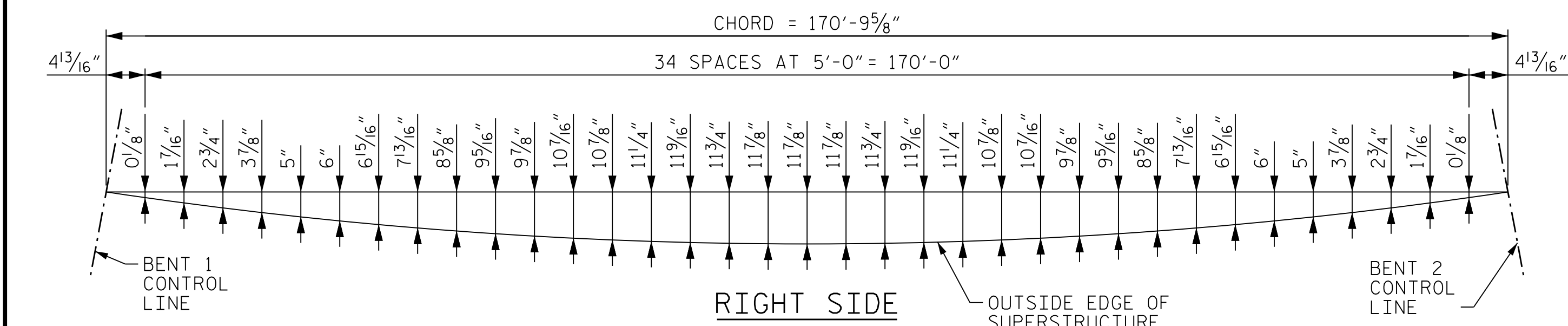
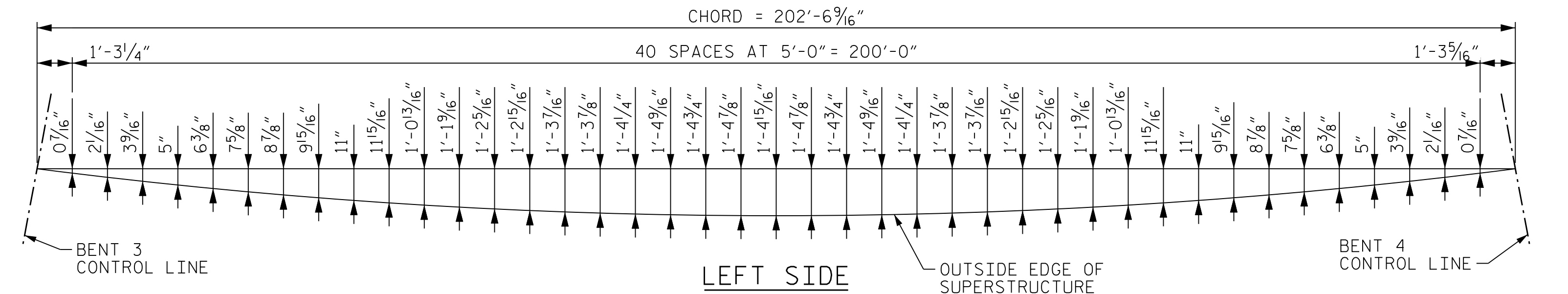
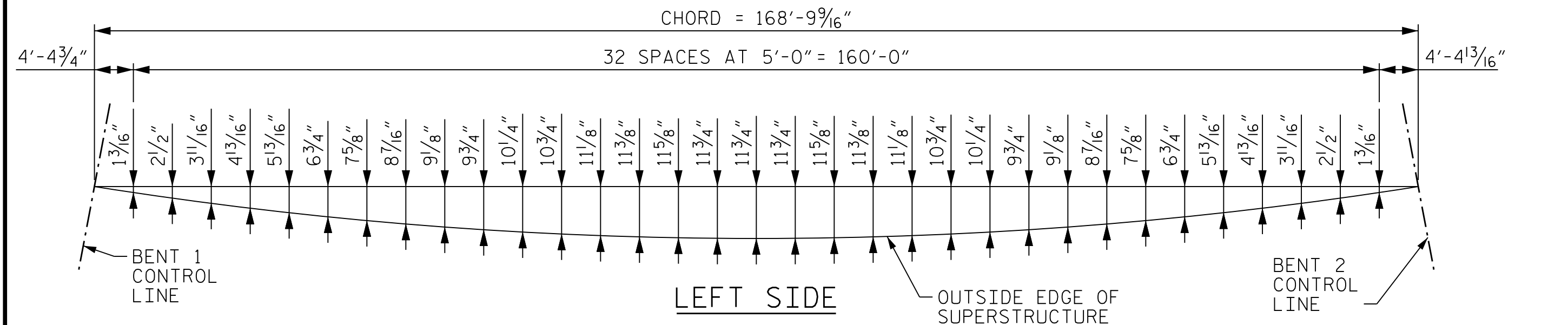

OUTSIDE EDGE ARC OFFSETS - SPAN B

OUTSIDE EDGE ARC OFFSETS - SPAN D

PROJECT NO. U-2579AB

FORSYTH COUNTY

STATION: 60+66.06 -Y15FLYAC-

SHEET 1 OF 4

STATE OF NORTH CAROLINA  
 DEPARTMENT OF TRANSPORTATION  
 RALEIGH

SUPERSTRUCTURE  
 PLAN OF SPANS  
 ARC OFFSETS

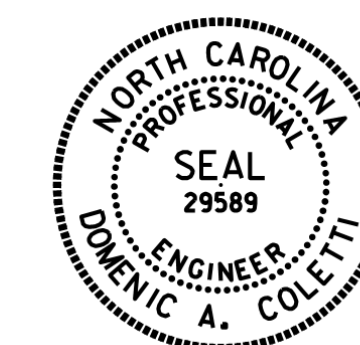

10/15/2021

DES BY: B. PETERSON	DATE: 06/19	DWG BY: B. PETERSON	DATE: 06/19
DES CHK: S. NIFONG	DATE: 06/19	CHK BY: G. SCHMITZ	DATE: 09/19

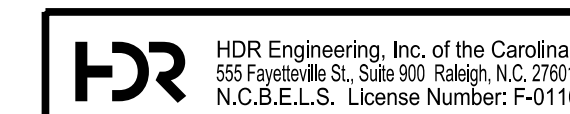

DOCUMENT NOT CONSIDERED FINAL  
 UNLESS ALL SIGNATURES COMPLETED

REVISIONS					
NO.	BY:	DATE:	NO.	BY:	DATE:
1	--	--	3	--	--
2	--	--	4	--	--

SHEET NO. S04-028
TOTAL SHEETS 144

PLOT DRIVER: NCDOT\_pdf\_color\_eng-50.ppt  
 USER: PPETERSO  
 DATE: 10/14/2021  
 TIME: 4:00:15 PM  
 FILE: ... \SUPERS



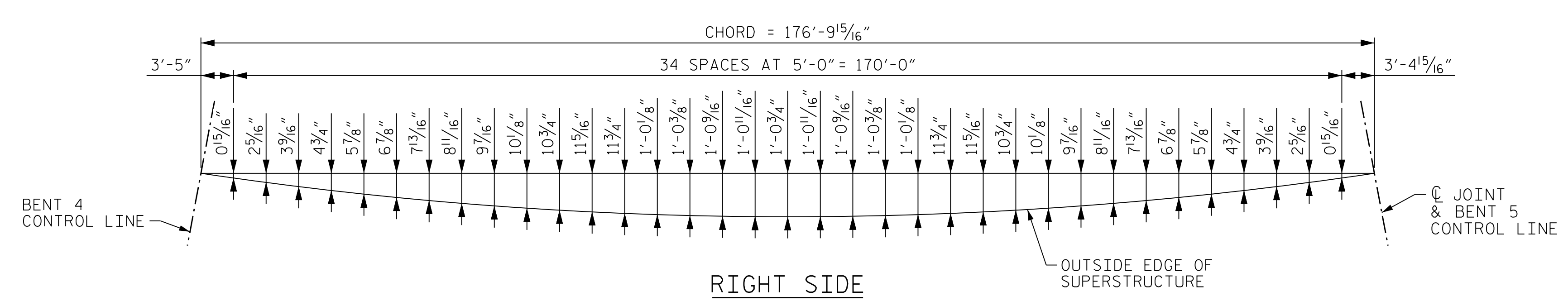
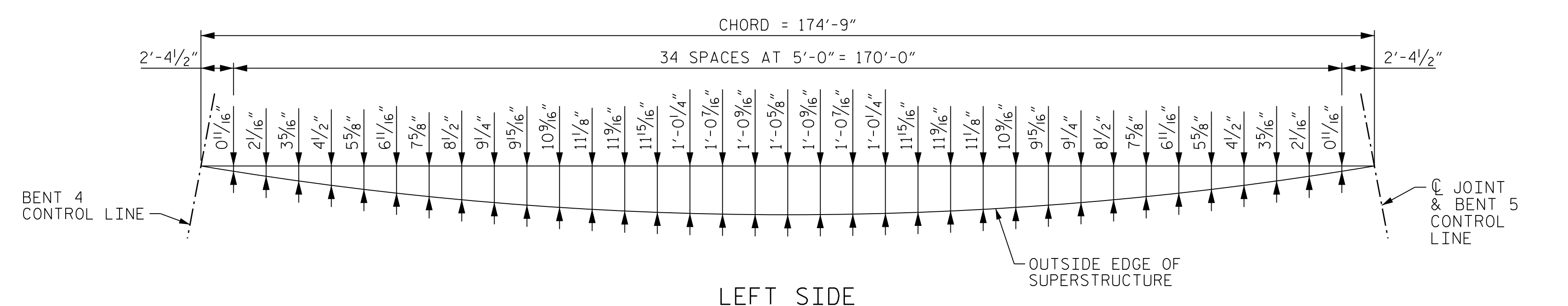

OUTSIDE EDGE ARC OFFSETS - SPAN E

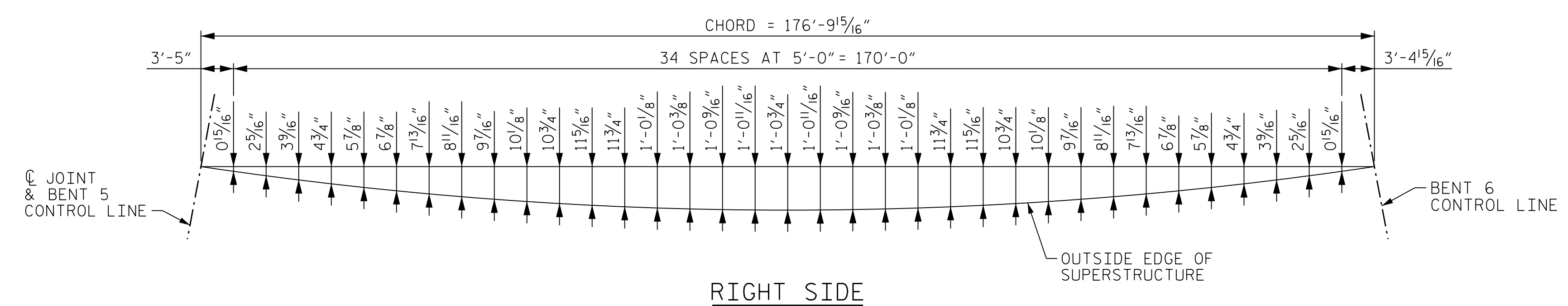
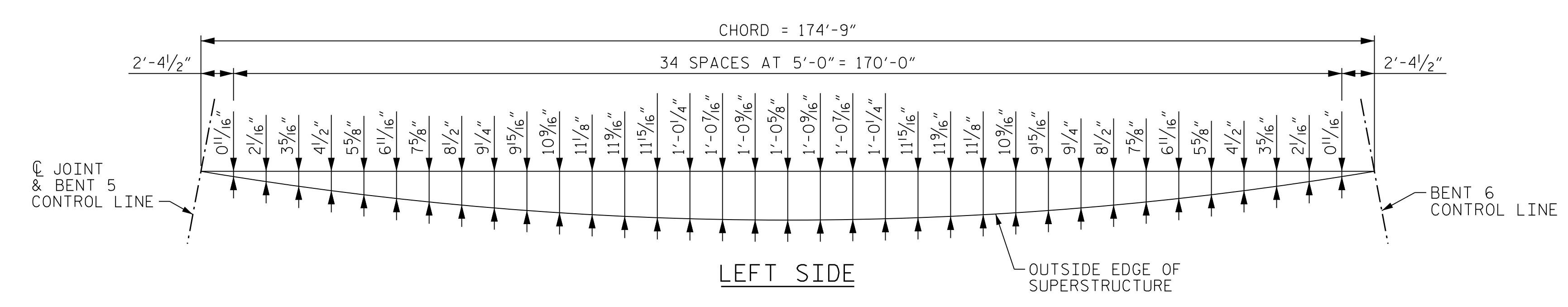

OUTSIDE EDGE ARC OFFSETS - SPAN F

PROJECT NO. U-2579AB  
 FORSYTH COUNTY  
 STATION: 60+66.06 -Y15FLYAC-  
 SHEET 2 OF 4

STATE OF NORTH CAROLINA  
 DEPARTMENT OF TRANSPORTATION  
 RALEIGH

SUPERSTRUCTURE  
 PLAN OF SPANS  
 ARC OFFSETS



REVISIONS					
NO.	BY:	DATE:	NO.	BY:	DATE:
1	--	--	3	--	--
2	--	--	4	--	--



10/15/2021  
 DOCUMENT NOT CONSIDERED FINAL  
 UNLESS ALL SIGNATURES COMPLETED

PLOT DRIVER: NCDOT\_pdf\_color\_eng-50.ppt  
 USER: PPETERSO DATE: 10/14/2021  
 PENTABLE: NCDOT\_STRUCTURES\_DEFAULT\_PEN.tbl  
 TIME: 4:00:17 PM  
 FILE: ... \SUPERS

DES BY: B. PETERSON	DATE: 06/19	DWG BY: B. PETERSON	DATE: 06/19
DES CHK: S. NIFONG	DATE: 06/19	CHK BY: G. SCHMITZ	DATE: 09/19

PLOT DRIVER: NCDOT\_PDF\_PEN\_COLOR\_eng-50.ppt  
 USER: PPETERSO DATE: 10/14/2021  
 TIME: 4:00:18 PM  
 FILE: ... \ASUPERS

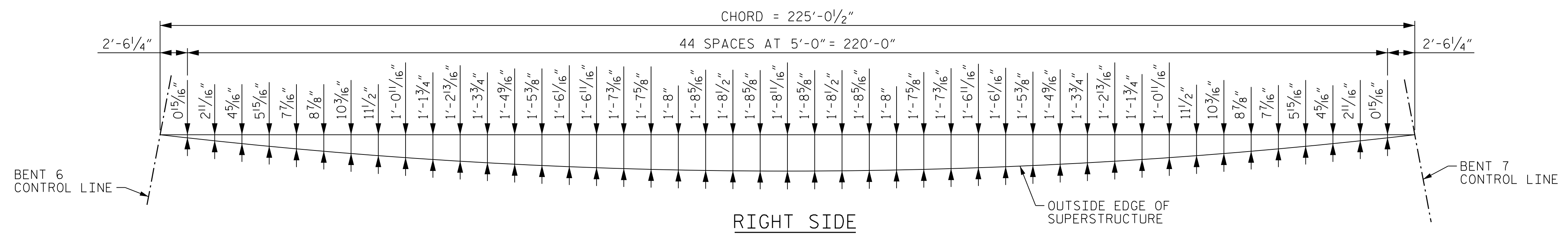
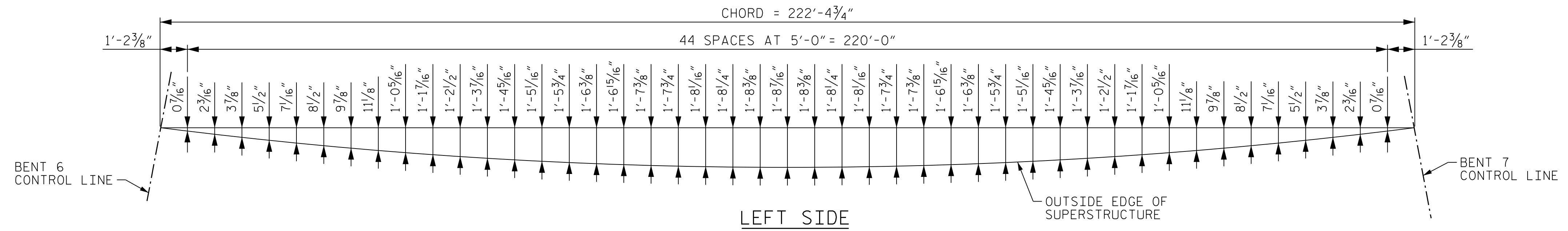

OUTSIDE EDGE ARC OFFSETS - SPAN G

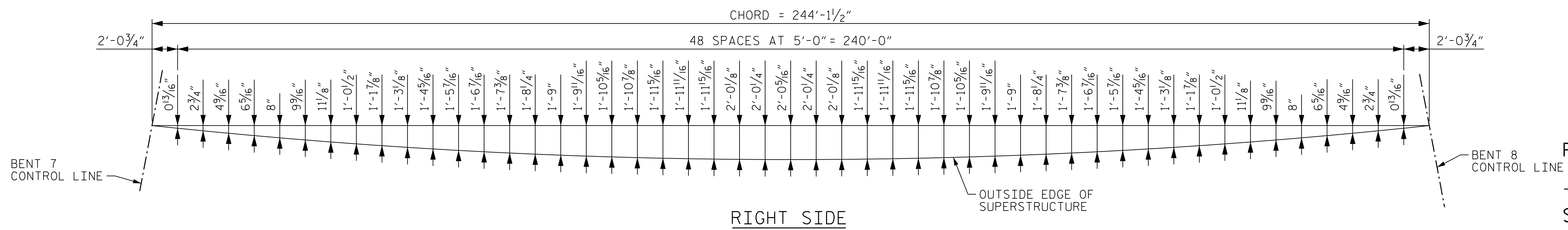
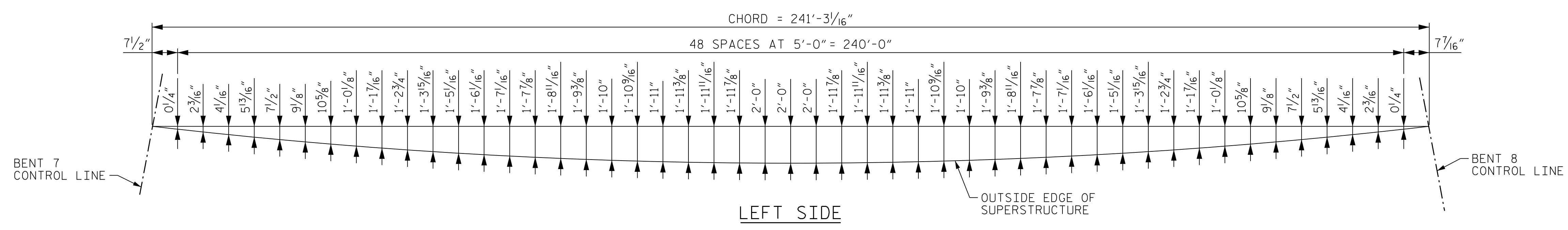

OUTSIDE EDGE ARC OFFSETS - SPAN H

PROJECT NO. U-2579AB  
 FORSYTH COUNTY  
 STATION: 60+66.06 -Y15FLYAC-  
 SHEET 3 OF 4

STATE OF NORTH CAROLINA  
 DEPARTMENT OF TRANSPORTATION  
 RALEIGH

SUPERSTRUCTURE  
 PLAN OF SPANS  
 ARC OFFSETS

REVISIONS					
NO.	BY:	DATE:	NO.	BY:	DATE:
1	--	--	3	--	--
2	--	--	4	--	--

SEAL  
 29589  
 ENGINEER  
 DOMENIC A. COLETTI

10/15/2021

SHEET NO. 144  
 TOTAL SHEETS 144

DES BY: B. PETERSON	DATE: 06/19	DWG BY: B. PETERSON	DATE: 06/19
DES CHK: S. NIFONG	DATE: 06/19	CHK BY: G. SCHMITZ	DATE: 09/19



DOCUMENT NOT CONSIDERED FINAL  
 UNLESS ALL SIGNATURES COMPLETED

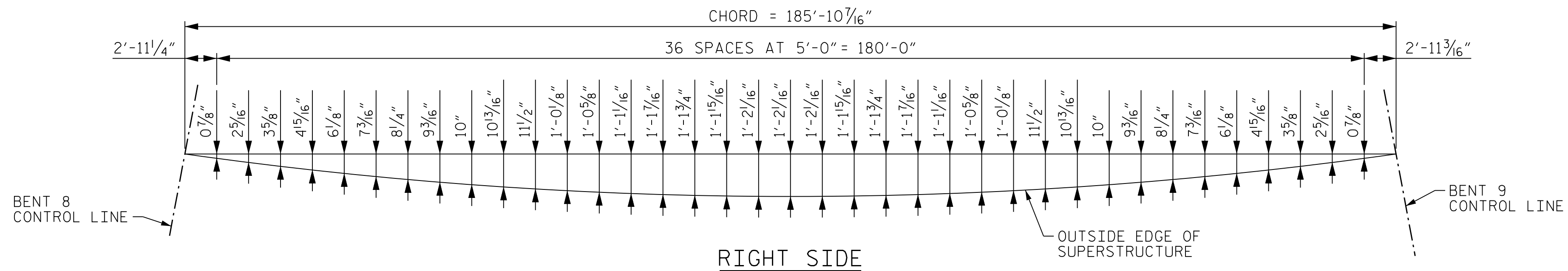
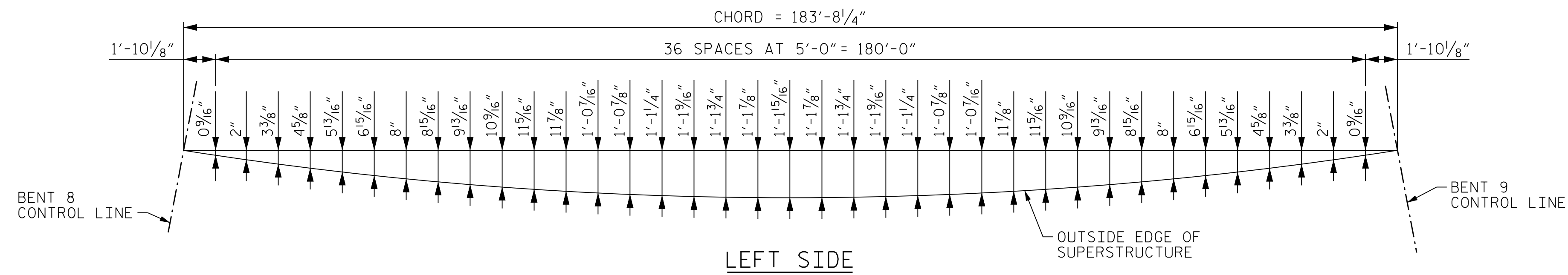

OUTSIDE EDGE ARC OFFSETS - SPAN I

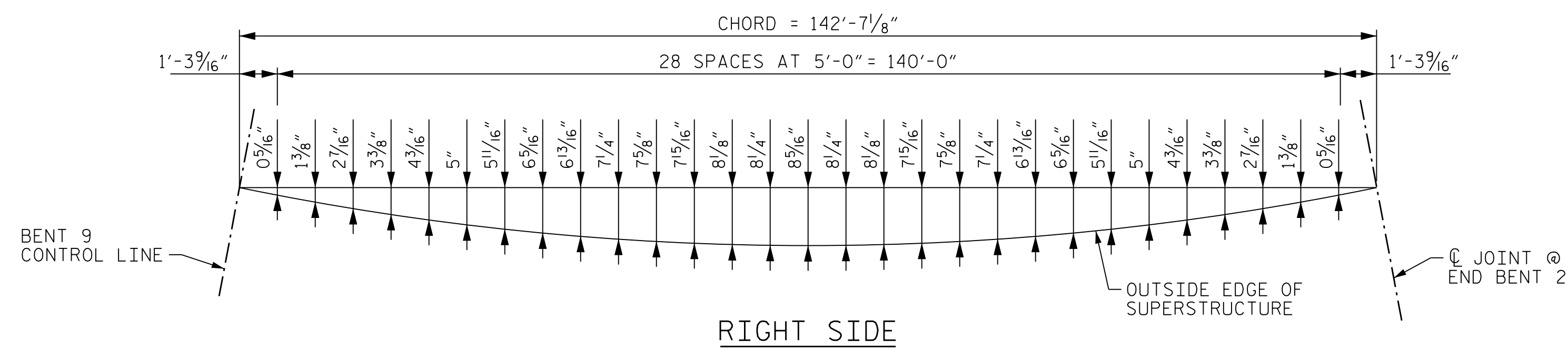
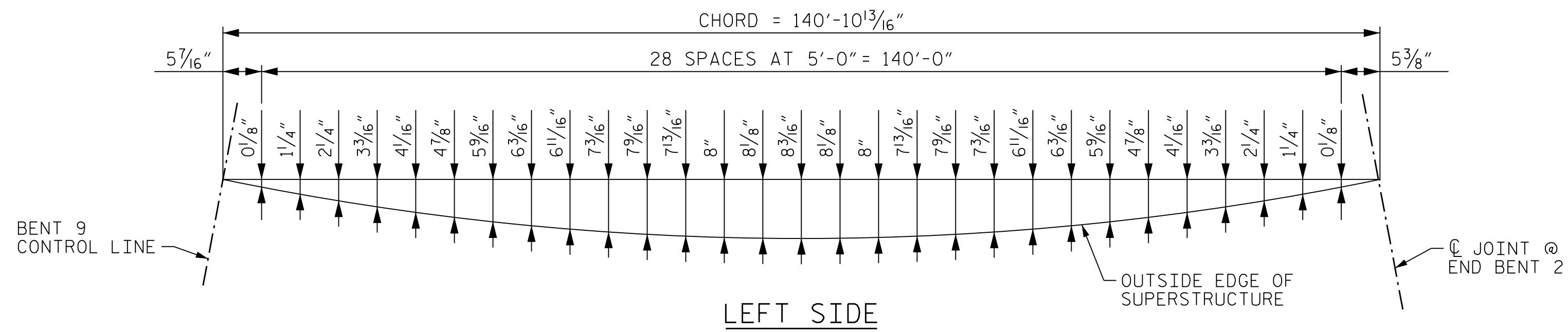

OUTSIDE EDGE ARC OFFSETS - SPAN J

PROJECT NO. U-2579AB  
 FORSYTH COUNTY  
 STATION: 60+66.06 -Y15FLYAC-  
 SHEET 4 OF 4

STATE OF NORTH CAROLINA  
 DEPARTMENT OF TRANSPORTATION  
 RALEIGH

SUPERSTRUCTURE  
 PLAN OF SPANS  
 ARC OFFSETS

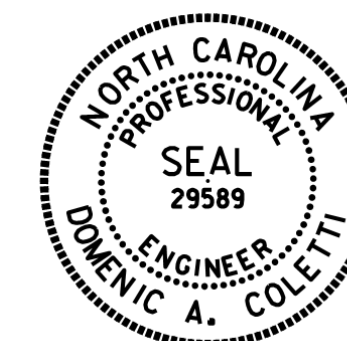

10/15/2021

REVISIONS

NO.	BY:	DATE:	NO.	BY:	DATE:
1	--	--	3	--	--
2	--	--	4	--	--

SHEET NO. S04-031  
 TOTAL SHEETS 144



HDR Engineering, Inc. of the Carolinas  
 555 Fayetteville St., Suite 900 Raleigh, N.C. 27601  
 N.C.B.E.L.S. License Number: F-0116

DOCUMENT NOT CONSIDERED FINAL  
 UNLESS ALL SIGNATURES COMPLETED

PLOT DRIVER: NCDOT\_pdf\_color\_eng\_50.ppt  
 USER: PPETERSO  
 FILE: ... \SUPERS  
 PENTABLE: NCDOT\_STRUCTURES\_DEFAULT\_PEN.tbl  
 TIME: 4:00:19 PM  
 DATE: 10/14/2021

DES BY: B. PETERSON	DATE: 06/19	DWG BY: B. PETERSON	DATE: 06/19
DES CHK: S. NIFONG	DATE: 06/19	CHK BY: G. SCHMITZ	DATE: 09/19

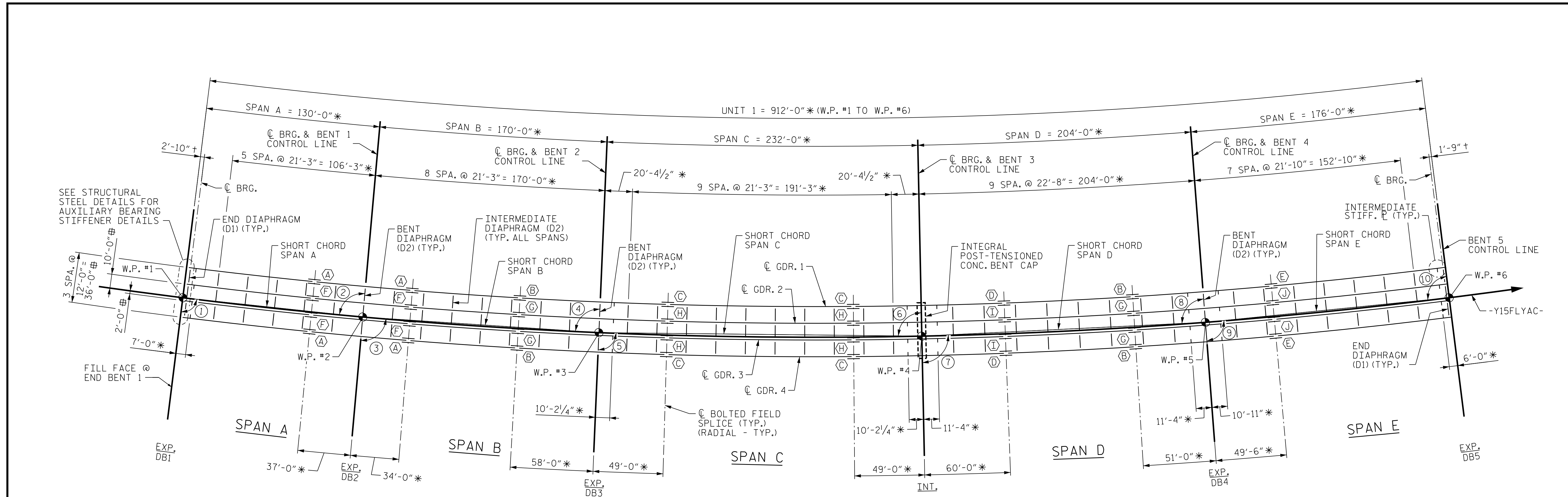

**FRAMING PLAN - UNIT 1**

**STRUCTURAL STEEL NOTES**

ALL STRUCTURAL STEEL SHALL BE AASHTO M270 GRADE 50W AND PAINTED IN ACCORDANCE WITH SYSTEM 5 OR SYSTEM 6 OF THE STRUCTURAL STEEL SHOP COATINGS PROGRAM AND SECTION 442-8 OF THE STANDARD SPECIFICATIONS UNLESS OTHERWISE NOTED IN THE PLANS.

ALL DIMENSIONS SHOWN ARE HORIZONTAL OR VERTICAL, UNLESS OTHERWISE NOTED.

ALL FIELD CONNECTIONS TO BE 7/8" Ø DIA. HIGH STRENGTH BOLTS UNLESS OTHERWISE NOTED.

BEARING STIFFENERS ARE TO BE PLACED NORMAL TO THE WEB OF THE GIRDER AND SHALL BE PLUMB IN THE FINAL CONDITION.

PERMITTED FLANGE AND WEB SHOP SPLICES SHALL NOT BE LOCATED WITHIN 15 FEET OF MAXIMUM DEAD LOAD DEFLECTION (NOR WITHIN 15 FEET OF INTERMEDIATE BEARINGS OF CONTINUOUS UNITS). KEEP 2 FEET MINIMUM BETWEEN WEB AND FLANGE SHOP SPLICES. KEEP 6" MINIMUM BETWEEN CONNECTOR PLATE OR TRANSVERSE STIFFENER WELD AND WEB OR FLANGE SHOP SPLICES.

STUDS ON GIRDERS MAY BE SHIFTED UP TO 1" IF NECESSARY TO CLEAR FLANGE SPLICE WELDS.

TENSION ON THE AASHTO M164 BOLTS SHALL BE CALIBRATED USING DIRECT TENSION INDICATOR WASHERS IN ACCORDANCE WITH ARTICLE 440-8 OF THE STANDARD SPECIFICATIONS.

ENDS OF GIRDERS SHALL BE PLUMB IN THE FINAL CONDITION.

BEARING STIFFENER MAY REQUIRE COPING IF WIDER THAN BOTTOM FLANGE.

STRUCTURAL STEEL ERECTION IN A CONTINUOUS UNIT SHALL BE COMPLETE BEFORE FALSEWORK OR FORMS ARE PLACED ON THE UNIT.

FOR TEMPORARY BENTS, SEE SPECIAL PROVISIONS.

FABRICATORS SHALL DETAIL DIAPHRAGM MEMBERS AND CONNECTIONS FOR NO-LOAD FIT UP.

FOR FIELD SPLICE TYPES, SEE "SUPERSTRUCTURE BOLTED FIELD SPLICE DETAILS" SHEETS.

FOR DIAPHRAGM TYPES, SEE "SUPERSTRUCTURE STRUCTURAL STEEL DETAILS" SHEETS.

**ANGLES TO SHORT CHORD**

- ① 91°01'03"
- ② 88°58'57"
- ③ 91°19'50"
- ④ 88°40'10"
- ⑤ 91°48'57"
- ⑥ 88°11'03"
- ⑦ 91°35'48"
- ⑧ 88°24'12"
- ⑨ 91°22'39"
- ⑩ 88°37'21"

PROJECT NO. U-2579AB  
 FORSYTH COUNTY  
 STATION: 60+66.06 -Y15FLYAC-

STATE OF NORTH CAROLINA  
 DEPARTMENT OF TRANSPORTATION  
 RALEIGH

**SUPERSTRUCTURE FRAMING PLAN UNIT 1**



10/15/2021

DES BY: G. SCHMITZ	DATE: 07/19	DWG BY: B. PETERSON	DATE: 07/19
DES CHK: D. COLETTI	DATE: 08/19	CHK BY: G. SCHMITZ	DATE: 10/19

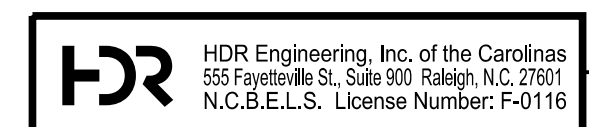

DOCUMENT NOT CONSIDERED FINAL UNLESS ALL SIGNATURES COMPLETED

REVISIONS						SHEET NO.	
NO.	BY:	DATE:	NO.	BY:	DATE:	TOTAL SHEETS	
1	--	--	3	--	--	144	
2	--	--	4	--	--	144	

PLOT DRIVER: NCDOT.pdf\_color\_eng-50dpi  
 USER: PETERSON  
 DATE: 10/14/2021  
 TIME: 4:00:29 PM  
 FILE: ... \SUSPERS

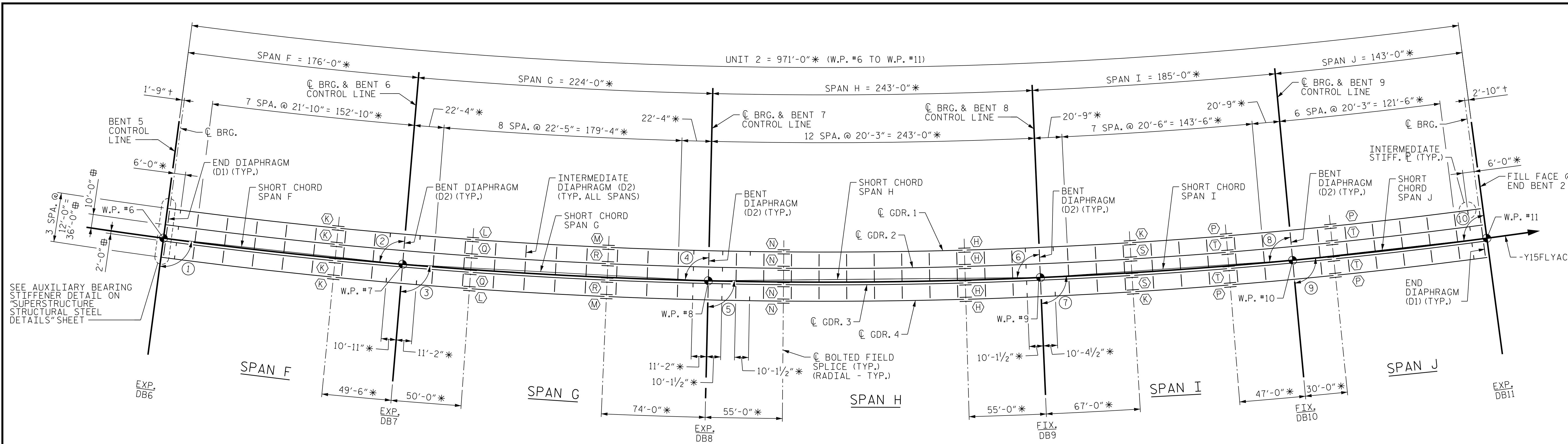

SEE AUXILIARY BEARING STIFFENER DETAIL ON "SUPERSTRUCTURE STRUCTURAL STEEL DETAILS" SHEET

EXP. DB6

EXP. DB7

EXP. DB8

FIX. DB9

FIX. DB10

EXP. DB11

### FRAMING PLAN - UNIT 2

\* = ARC LENGTH ALONG -Y15FLYAC-  
 # = RADIAL DIMENSION  
 † = MEASURED PERPENDICULAR TO BENT CONTROL LINE OR END BENT FILL FACE  
 ⊗ = FIELD SPLICE TYPE

#### ANGLES TO SHORT CHORD

- ① 91°22'39"
- ② 88°37'21"
- ③ 91°45'12"
- ④ 88°14'48"
- ⑤ 91°54'07"
- ⑥ 88°05'53"
- ⑦ 91°26'53"
- ⑧ 88°33'07"
- ⑨ 91°07'09"
- ⑩ 88°52'51"

#### NOTE

SEE "SUPERSTRUCTURE FRAMING PLAN - UNIT 1" SHEET FOR STRUCTURAL STEEL NOTES.

PROJECT NO. U-2579AB  
 FORSYTH COUNTY  
 STATION: 60+66.06 -Y15FLYAC-

STATE OF NORTH CAROLINA  
 DEPARTMENT OF TRANSPORTATION  
 RALEIGH

**SUPERSTRUCTURE FRAMING PLAN  
 UNIT 2**

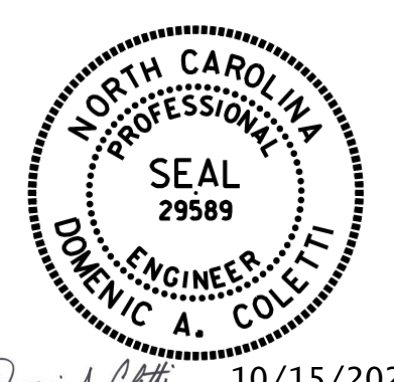

10/15/2021

DES BY: T. ANDREWS	DATE: 07/19	DWG BY: B. PETERSON	DATE: 07/19
DES CHK: D. OLDS	DATE: 08/19	CHK BY: T. ANDREWS	DATE: 10/19

**HDR** HDR Engineering, Inc. of the Carolinas  
 555 Fayetteville St., Suite 900 Raleigh, N.C. 27601  
 N.C.B.E.L.S. License Number: F-0116

DOCUMENT NOT CONSIDERED FINAL  
 UNLESS ALL SIGNATURES COMPLETED

REVISIONS						SHEET NO. S04-033 TOTAL SHEETS 144
NO.	BY:	DATE:	NO.	BY:	DATE:	
1	--	--	3	--	--	
2	--	--	4	--	--	

PLOT DRIVER: NCDOT.pdf\_color\_eng-50.ppt  
 USER: PPETERSO DATE: 10/14/2021  
 PENTABLE: NCDOT\_STRUCTURES\_DEFAULT\_PEN.tbl  
 TIME: 4:00:38 PM  
 FILE: ... \SUSPERS

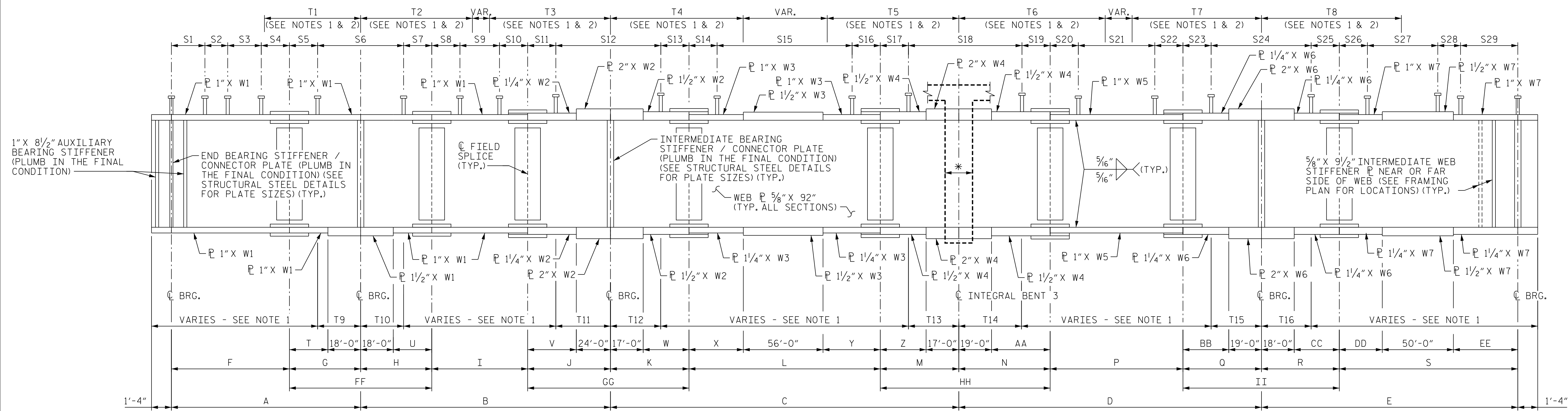

**ELEVATION**

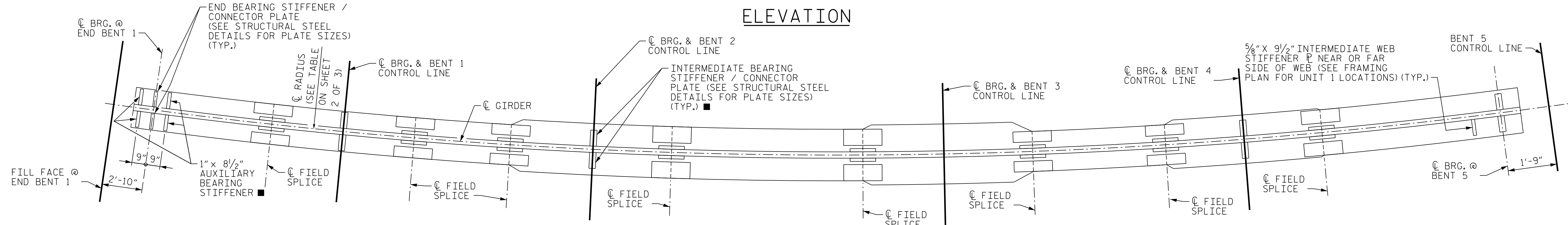

**PLAN OF BOTTOM FLANGE NOTES**

1. CHARPY V-NOTCH TESTS ARE REQUIRED FOR ALL TOP OR BOTTOM FLANGE PLATES WHICH FALL WITHIN THESE LIMITS, ALL WEB PLATES AND ALL SPLICE PLATES. IF A PERMITTED SHOP FLANGE SPLICE IS NOT USED, CHARPY V-NOTCH TESTS WILL BE REQUIRED FOR THE ENTIRE FLANGE PLATE. FOR CHARPY V-NOTCH TESTS, SEE ARTICLE 1072-7 OF THE STANDARD SPECIFICATIONS.
2. NO WELDING OF FORMS OR FALSEWORK TO THE TOP FLANGE WILL BE PERMITTED IN THIS REGION.
3. DIMENSIONS ARE HORIZONTAL ARC DIMENSIONS ALONG THE C OF GIRDER. NO CORRECTIONS HAVE BEEN MADE TO ADJUST FOR THE DISTANCE ALONG THE GRADE.
4. FOR SHEAR CONNECTOR TRANSVERSE SPACING, SEE "STRUCTURAL STEEL DETAILS" SHEET.
5. FOR CHARPY V-NOTCH TEST, SEE SPECIAL PROVISIONS.
6. FOR DIMENSIONS, SEE SHEET 2 OF 3.
7. SEE SHEET "FRAMING PLAN - UNIT 1" FOR FIELD SPLICE TYPES.

\* = INTEGRAL BENT CAP - SEE SHEET 3 OF 3 FOR STEEL FABRICATION DETAILS AT BENT 3

■ = SEE TABLE OF BEARING STIFFENERS ON "STRUCTURAL STEEL DETAILS" SHEET 1 OF 2.

PROJECT NO. U-2579AB  
 FORSYTH COUNTY  
 STATION: 60+66.06 -Y15FLYAC-

SHEET 1 OF 3

STATE OF NORTH CAROLINA  
 DEPARTMENT OF TRANSPORTATION  
 RALEIGH

**SUPERSTRUCTURE GIRDER DETAILS UNIT 1**



10/15/2021

REVISIONS					
NO.	BY:	DATE:	NO.	BY:	DATE:
1	--	--	3	--	--
2	--	--	4	--	--

SHEET NO. 504-034  
 TOTAL SHEETS 144

DOCUMENT NOT CONSIDERED FINAL UNLESS ALL SIGNATURES COMPLETED

PLOT DRIVER: NCDOT.pdf\_color\_eng-50dpi  
 USER: PPETERSO DATE: 10/14/2021  
 PENTABLE: NCDOT\_STRUCTURES\_DEFAULT\_PEN.tbl  
 TIME: 4:00:45 PM  
 FILE: ... \ASUPERS

DES BY: G. SCHMITZ	DATE: 07/19	DWG BY: B. PETERSON	DATE: 07/19
DES CHK: D. COLETTI	DATE: 08/19	CHK BY: G. SCHMITZ	DATE: 10/19

GIRDER DIMENSIONS

GIRDER	CL RADIUS	A	B	C	D	E	F	G	H	I	J	K	L	M	N	P	Q	R	S	T	U	V	W	X	Y	Z
1	3638'-0"	126'-4 <sup>5</sup> / <sub>8</sub> "	168'-11 <sup>3</sup> / <sub>4</sub> "	230'-7 <sup>1</sup> / <sub>4</sub> "	202'-9 <sup>5</sup> / <sub>16</sub> "	173'-2 <sup>5</sup> / <sub>16</sub> "	89'-7 <sup>5</sup> / <sub>16</sub> "	36'-9 <sup>5</sup> / <sub>16</sub> "	33'-9 <sup>9</sup> / <sub>16</sub> "	77'-6 <sup>3</sup> / <sub>8</sub> "	57'-7 <sup>3</sup> / <sub>16</sub> "	48'-8 <sup>7</sup> / <sub>16</sub> "	133'-2 <sup>3</sup> / <sub>8</sub> "	48'-8 <sup>7</sup> / <sub>16</sub> "	59'-7 <sup>11</sup> / <sub>16</sub> "	92'-5 <sup>5</sup> / <sub>16</sub> "	50'-8 <sup>5</sup> / <sub>16</sub> "	49'-2 <sup>7</sup> / <sub>16</sub> "	123'-11 <sup>7</sup> / <sub>8</sub> "	18'-9 <sup>5</sup> / <sub>16</sub> "	15'-9 <sup>9</sup> / <sub>16</sub> "	33'-7 <sup>3</sup> / <sub>16</sub> "	31'-8 <sup>7</sup> / <sub>16</sub> "	37'-7 <sup>1</sup> / <sub>4</sub> "	39'-7 <sup>1</sup> / <sub>16</sub> "	31'-8 <sup>7</sup> / <sub>16</sub> "
2	3650'-0"	126'-9 <sup>3</sup> / <sub>4</sub> "	169'-6 <sup>7</sup> / <sub>16</sub> "	231'-4 <sup>3</sup> / <sub>8</sub> "	203'-5 <sup>5</sup> / <sub>16</sub> "	173'-9 <sup>1</sup> / <sub>4</sub> "	89'-10 <sup>5</sup> / <sub>16</sub> "	36'-10 <sup>13</sup> / <sub>16</sub> "	33'-10 <sup>7</sup> / <sub>8</sub> "	77'-9 <sup>7</sup> / <sub>16</sub> "	57'-10 <sup>1</sup> / <sub>8</sub> "	48'-10 <sup>3</sup> / <sub>8</sub> "	133'-7 <sup>5</sup> / <sub>8</sub> "	48'-10 <sup>3</sup> / <sub>8</sub> "	59'-10 <sup>1</sup> / <sub>16</sub> "	92'-8 <sup>15</sup> / <sub>16</sub> "	50'-10 <sup>5</sup> / <sub>16</sub> "	49'-4 <sup>3</sup> / <sub>8</sub> "	124'-4 <sup>7</sup> / <sub>8</sub> "	18'-10 <sup>3</sup> / <sub>16</sub> "	15'-10 <sup>7</sup> / <sub>8</sub> "	33'-10 <sup>1</sup> / <sub>8</sub> "	31'-10 <sup>3</sup> / <sub>8</sub> "	37'-9 <sup>3</sup> / <sub>16</sub> "	39'-9 <sup>3</sup> / <sub>4</sub> "	31'-10 <sup>3</sup> / <sub>8</sub> "
3	3662'-0"	127'-2 <sup>7</sup> / <sub>8</sub> "	170'-1 <sup>1</sup> / <sub>8</sub> "	232'-1 <sup>1</sup> / <sub>2</sub> "	204'-1 <sup>5</sup> / <sub>16</sub> "	174'-4 <sup>1</sup> / <sub>8</sub> "	90'-2 <sup>5</sup> / <sub>8</sub> "	37'-0 <sup>1</sup> / <sub>4</sub> "	34'-0 <sup>1</sup> / <sub>4</sub> "	78'-0 <sup>1</sup> / <sub>2</sub> "	58'-0 <sup>3</sup> / <sub>8</sub> "	49'-0 <sup>5</sup> / <sub>16</sub> "	134'-0 <sup>7</sup> / <sub>8</sub> "	49'-0 <sup>5</sup> / <sub>16</sub> "	60'-0 <sup>3</sup> / <sub>8</sub> "	93'-0 <sup>5</sup> / <sub>8</sub> "	51'-0 <sup>5</sup> / <sub>16</sub> "	49'-6 <sup>5</sup> / <sub>16</sub> "	124'-9 <sup>3</sup> / <sub>16</sub> "	19'-0 <sup>1</sup> / <sub>4</sub> "	16'-0 <sup>1</sup> / <sub>4</sub> "	34'-0 <sup>3</sup> / <sub>8</sub> "	32'-0 <sup>5</sup> / <sub>16</sub> "	38'-0 <sup>7</sup> / <sub>16</sub> "	40'-0 <sup>7</sup> / <sub>16</sub> "	32'-0 <sup>5</sup> / <sub>16</sub> "
4	3674'-0"	127'-7 <sup>5</sup> / <sub>16</sub> "	170'-7 <sup>3</sup> / <sub>16</sub> "	232'-10 <sup>5</sup> / <sub>16</sub> "	204'-9 <sup>3</sup> / <sub>8</sub> "	174'-11 <sup>1</sup> / <sub>16</sub> "	90'-6 <sup>1</sup> / <sub>4</sub> "	37'-1 <sup>11</sup> / <sub>16</sub> "	34'-1 <sup>9</sup> / <sub>16</sub> "	78'-3 <sup>9</sup> / <sub>16</sub> "	58'-2 <sup>11</sup> / <sub>16</sub> "	49'-2 <sup>1</sup> / <sub>4</sub> "	134'-6 <sup>1</sup> / <sub>8</sub> "	49'-2 <sup>1</sup> / <sub>4</sub> "	60'-2 <sup>3</sup> / <sub>4</sub> "	93'-4 <sup>5</sup> / <sub>16</sub> "	51'-2 <sup>5</sup> / <sub>16</sub> "	49'-8 <sup>1</sup> / <sub>4</sub> "	125'-2 <sup>13</sup> / <sub>16</sub> "	19'-1 <sup>11</sup> / <sub>16</sub> "	16'-1 <sup>9</sup> / <sub>16</sub> "	34'-2 <sup>11</sup> / <sub>16</sub> "	32'-2 <sup>1</sup> / <sub>4</sub> "	38'-3"	40'-3 <sup>1</sup> / <sub>8</sub> "	32'-2 <sup>1</sup> / <sub>4</sub> "

STUD SPACING DIMENSIONS																							
GIRDER	S1	S2	S3	S4	S5	S6	S7	S8	S9	S10	S11	S12	S13	S14	S15	S16	S17	S18	S19	S20			
1	20 SPA. @ 1'-1"	1'-1"	46 SPA. @ 1'-5"	1'-8 <sup>5</sup> / <sub>16</sub> "	2'-3 <sup>7</sup> / <sub>16</sub> "	72 SPA. @ 0'-11"	2'-3 <sup>7</sup> / <sub>16</sub> "	2'-6 <sup>3</sup> / <sub>16</sub> "	58 SPA. @ 1'-3"	2'-6 <sup>3</sup> / <sub>16</sub> "	2'-1 <sup>7</sup> / <sub>8</sub> "	79 SPA. @ 1'-3 <sup>1</sup> / <sub>2</sub> "	2'-1 <sup>7</sup> / <sub>8</sub> "	1'-11 <sup>3</sup> / <sub>16</sub> "	97 SPA. @ 1'-4"	1'-11 <sup>3</sup> / <sub>16</sub> "	2'-2 <sup>1</sup> / <sub>16</sub> "	78 SPA. @ 1'-4"	2'-2 <sup>1</sup> / <sub>16</sub> "	2'-2 <sup>5</sup> / <sub>8</sub> "			
2	49 SPA. @ 1'-1 <sup>1</sup> / <sub>2</sub> "	7"	39 SPA. @ 0'-10"	1'-8 <sup>7</sup> / <sub>16</sub> "	2'-0 <sup>13</sup> / <sub>16</sub> "	80 SPA. @ 0'-10"	2'-0 <sup>13</sup> / <sub>16</sub> "	2'-0 <sup>3</sup> / <sub>4</sub> "	52 SPA. @ 1'-5"	2'-0 <sup>3</sup> / <sub>4</sub> "	2'-0 <sup>1</sup> / <sub>4</sub> "	112 SPA. @ 0'-11"	2'-0 <sup>1</sup> / <sub>4</sub> "	2'-3 <sup>3</sup> / <sub>16</sub> "	86 SPA. @ 1'-6"	2'-3 <sup>3</sup> / <sub>16</sub> "	1'-11 <sup>3</sup> / <sub>16</sub> "	74 SPA. @ 1'-5"	1'-11 <sup>3</sup> / <sub>16</sub> "	2'-0 <sup>1</sup> / <sub>2</sub> "			
3	49 SPA. @ 1'-1 <sup>1</sup> / <sub>2</sub> "	7"	39 SPA. @ 0'-10"	2'-0 <sup>1</sup> / <sub>8</sub> "	2'-2 <sup>1</sup> / <sub>4</sub> "	80 SPA. @ 0'-10"	2'-2 <sup>1</sup> / <sub>4</sub> "	2'-2 <sup>1</sup> / <sub>4</sub> "	52 SPA. @ 1'-5"	2'-2 <sup>1</sup> / <sub>4</sub> "	2'-2 <sup>3</sup> / <sub>8</sub> "	112 SPA. @ 0'-11"	2'-2 <sup>3</sup> / <sub>8</sub> "	2'-6 <sup>7</sup> / <sub>16</sub> "	86 SPA. @ 1'-6"	2'-6 <sup>7</sup> / <sub>16</sub> "	2'-1 <sup>3</sup> / <sub>8</sub> "	74 SPA. @ 1'-5"	2'-1 <sup>3</sup> / <sub>8</sub> "	2'-2 <sup>5</sup> / <sub>16</sub> "			
4	20 SPA. @ 1'-1"	1'-5"	46 SPA. @ 1'-5"	2'-3 <sup>1</sup> / <sub>4</sub> "	2'-2 <sup>1</sup> / <sub>8</sub> "	73 SPA. @ 0'-11"	2'-2 <sup>1</sup> / <sub>8</sub> "	2'-10 <sup>3</sup> / <sub>16</sub> "	58 SPA. @ 1'-3"	2'-10 <sup>3</sup> / <sub>16</sub> "	2'-8 <sup>3</sup> / <sub>16</sub> "	79 SPA. @ 1'-3 <sup>1</sup> / <sub>2</sub> "	2'-8 <sup>3</sup> / <sub>16</sub> "	2'-7 <sup>1</sup> / <sub>16</sub> "	97 SPA. @ 1'-4"	2'-7 <sup>1</sup> / <sub>16</sub> "	2'-8 <sup>1</sup> / <sub>2</sub> "	78 SPA. @ 1'-4"	2'-8 <sup>1</sup> / <sub>2</sub> "	2'-8 <sup>1</sup> / <sub>8</sub> "			

LIMITS OF TENSION FLANGES FOR CHARPY V-NOTCH TESTS																
GIRDER	T1	T2	T3	T4	T5	T6	T7	T8	T9	T10	T11	T12	T13	T14	T15	T16
1	50'-0"	168'-11 <sup>3</sup> / <sub>4</sub> "	0	58'-0"	63'-0"	86'-0"	78'-0"	61'-0"	19'-0"	21'-0"	41'-0"	32'-0"	34'-0"	44'-0"	37'-0"	32'-0"
2	46'-0"	50'-0"	85'-0"	55'-0"	62'-0"	85'-0"	73'-0"	58'-0"	19'-0"	25'-0"	41'-0"	35'-0"	34'-0"	45'-0"	37'-0"	32'-0"
3	46'-0"	52'-0"	90'-0"	55'-0"	63'-0"	88'-0"	76'-0"	58'-0"	19'-0"	25'-0"	41'-0"	35'-0"	34'-0"	45'-0"	37'-0"	32'-0"
4	49'-0"	170'-7 <sup>3</sup> / <sub>16</sub> "	0	58'-0"	65'-0"	93'-0"	80'-0"	60'-0"	19'-0"	24'-0"	41'-0"	33'-0"	34'-0"	45'-0"	37'-0"	32'-0"

GIRDER FLANGE WIDTHS								
GIRDER	FLANGE	W1	W2	W3	W4	W5	W6	W7
1 & 4	TOP	18"	26"	24"	30"	18"	24"	18"
	BOTTOM	20"	30"	30"	36"	20"	28"	24"
2 & 3	TOP	18"	26"	24"	28"	18"	24"	18"
	BOTTOM	18"	26"	26"	34"	18"	24"	22"

NOTE  
SEE "SUPERSTRUCTURE GIRDER DETAILS,  
UNIT 1" SHEET 1 OF 3 FOR NOTES.

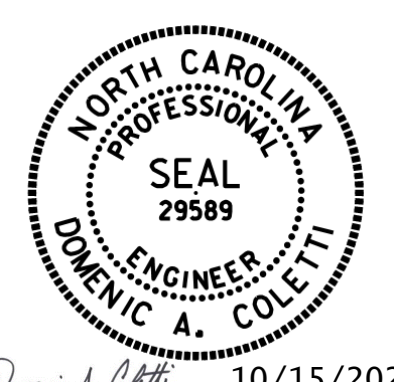

10/15/2021

PROJECT NO. U-2579AB  
FORSYTH COUNTY  
 STATION: 60+66.06 -Y15FLYAC-  
 SHEET 2 OF 3

STATE OF NORTH CAROLINA  
 DEPARTMENT OF TRANSPORTATION  
 RALEIGH

**SUPERSTRUCTURE  
 GIRDER DETAILS  
 UNIT 1**

REVISIONS						SHEET NO.
NO.	BY:	DATE:	NO.	BY:	DATE:	NO.
1	--	--	3	--	--	TOTAL SHEETS 144
2	--	--	4	--	--	

PLOT DRIVER: NCDOT.pdf\_color\_eng-50.ppt  
 USER: PPEIERSO DATE: 10/14/2021  
 FILE: ... \SUSPERS  
 PENTABLE: NCDOT STRUCTURES DEFAULT PEN.tbl  
 TIME: 4:00:53 PM

DES BY: <u>G. SCHMITZ</u>	DATE: <u>07/19</u>	DWG BY: <u>T. SAS</u>	DATE: <u>08/19</u>
DES CHK: <u>D. COLETTI</u>	DATE: <u>08/19</u>	CHK BY: <u>G. SCHMITZ</u>	DATE: <u>10/19</u>

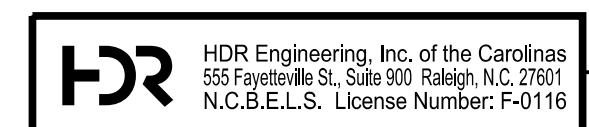

DOCUMENT NOT CONSIDERED FINAL  
 UNLESS ALL SIGNATURES COMPLETED

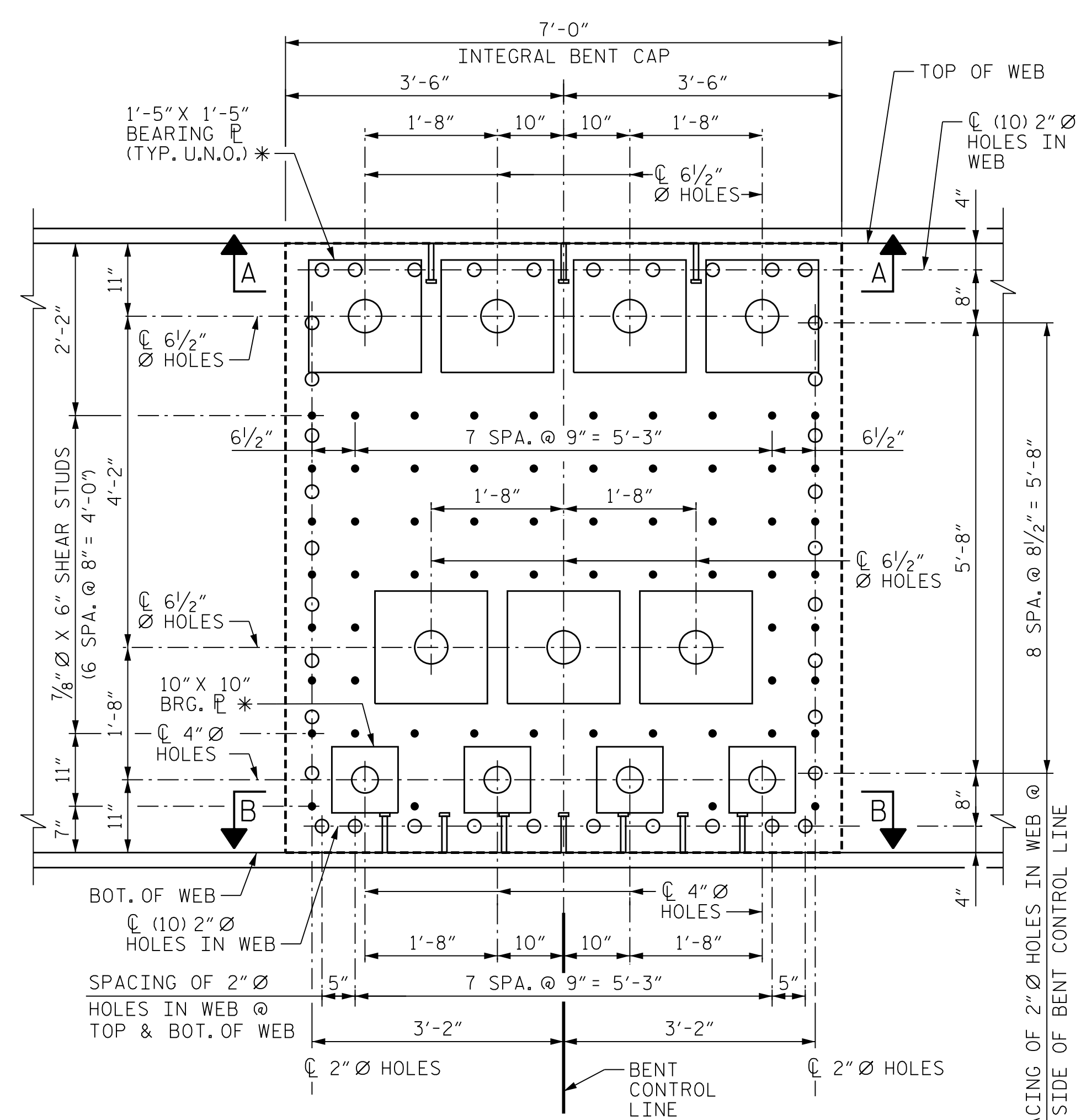

**GIRDERS 1 & 4 (EXTERIOR FACE)**  
(72 SHEAR STUDS REQ'D PER FACE)

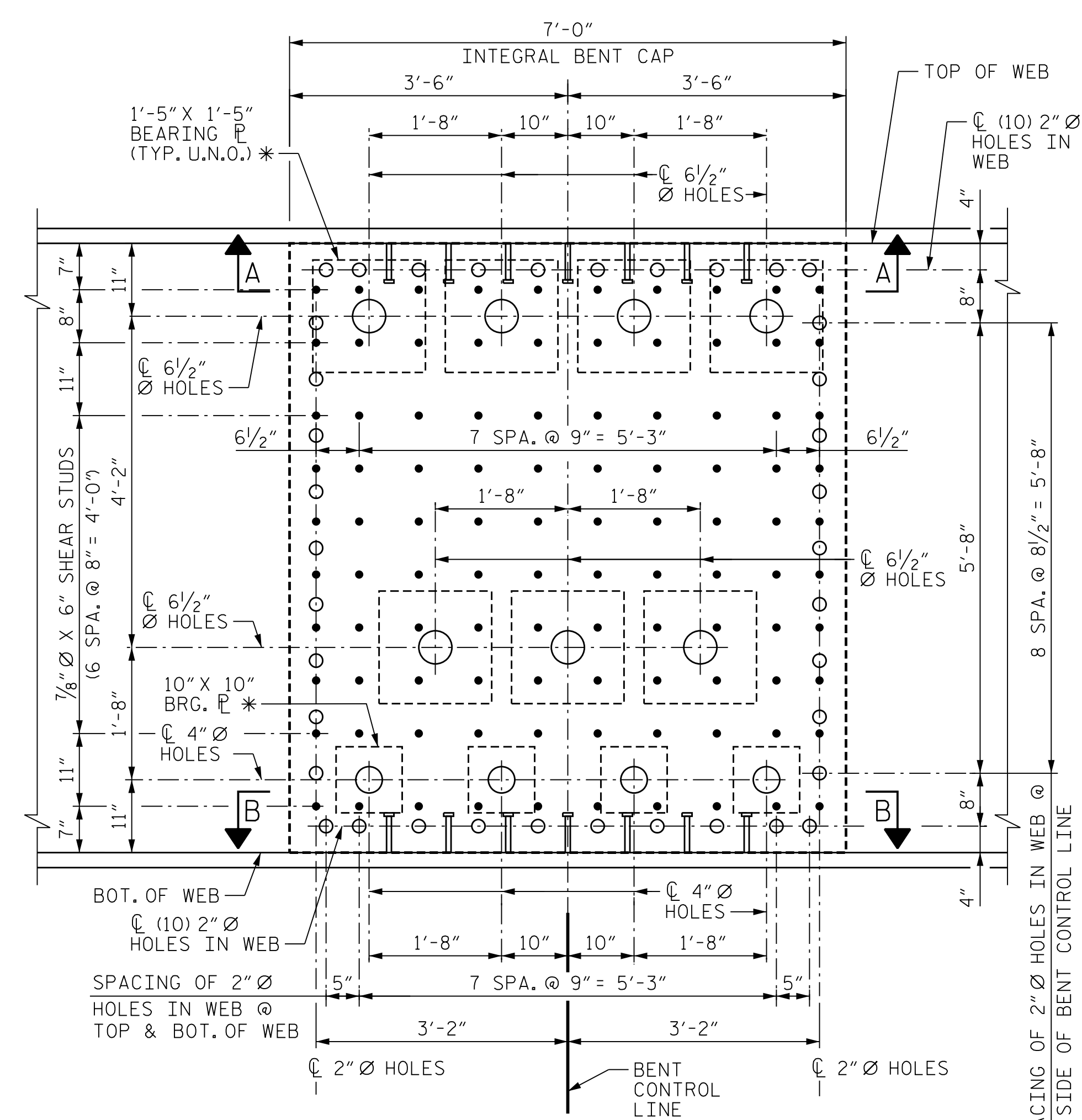

**GIRDERS 1 & 4 (INTERIOR FACE)**  
(114 SHEAR STUDS REQ'D PER FACE)

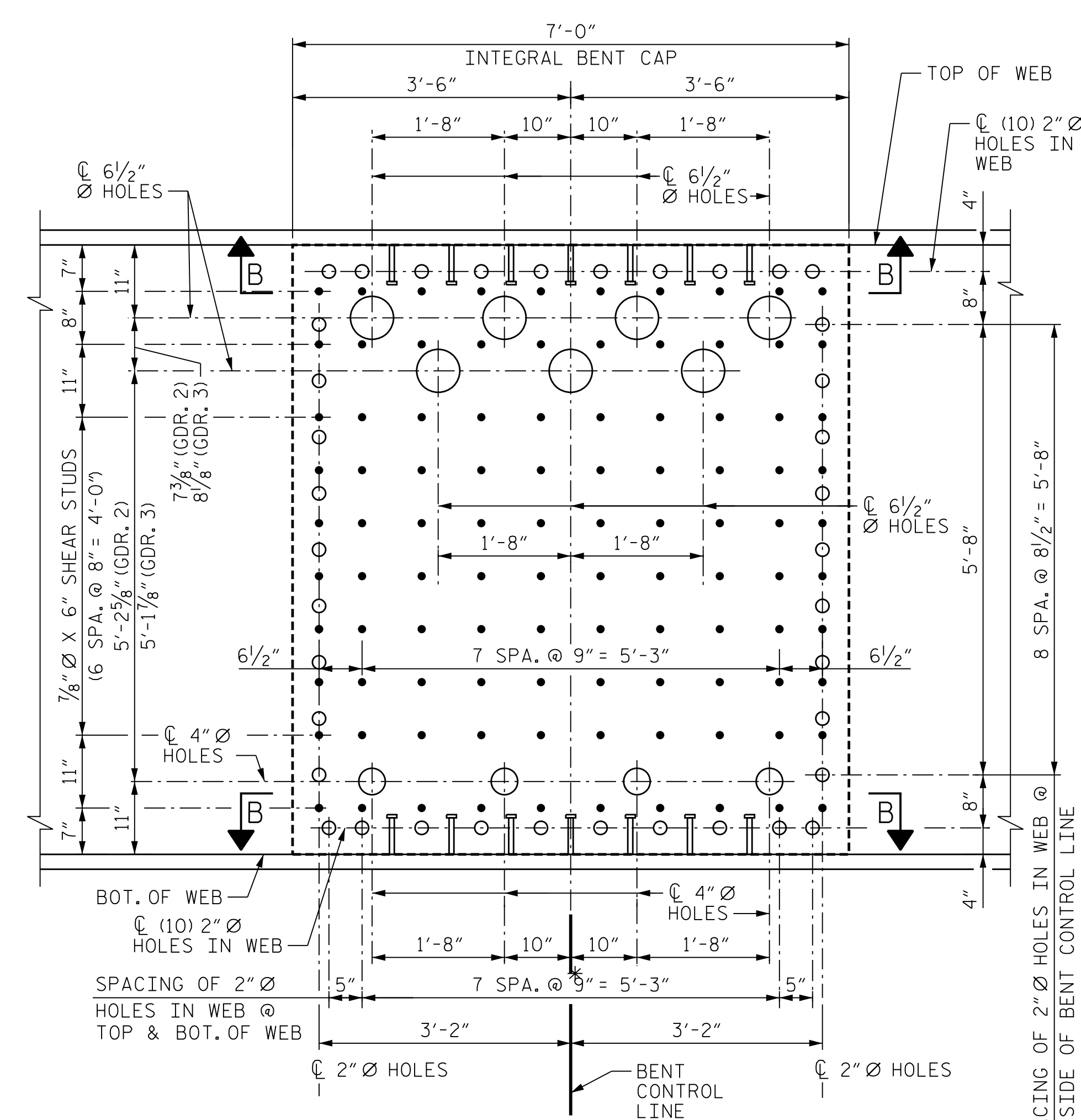

**GIRDERS 2 & 3 (BOTH FACES)**  
(114 SHEAR STUDS REQ'D PER FACE)

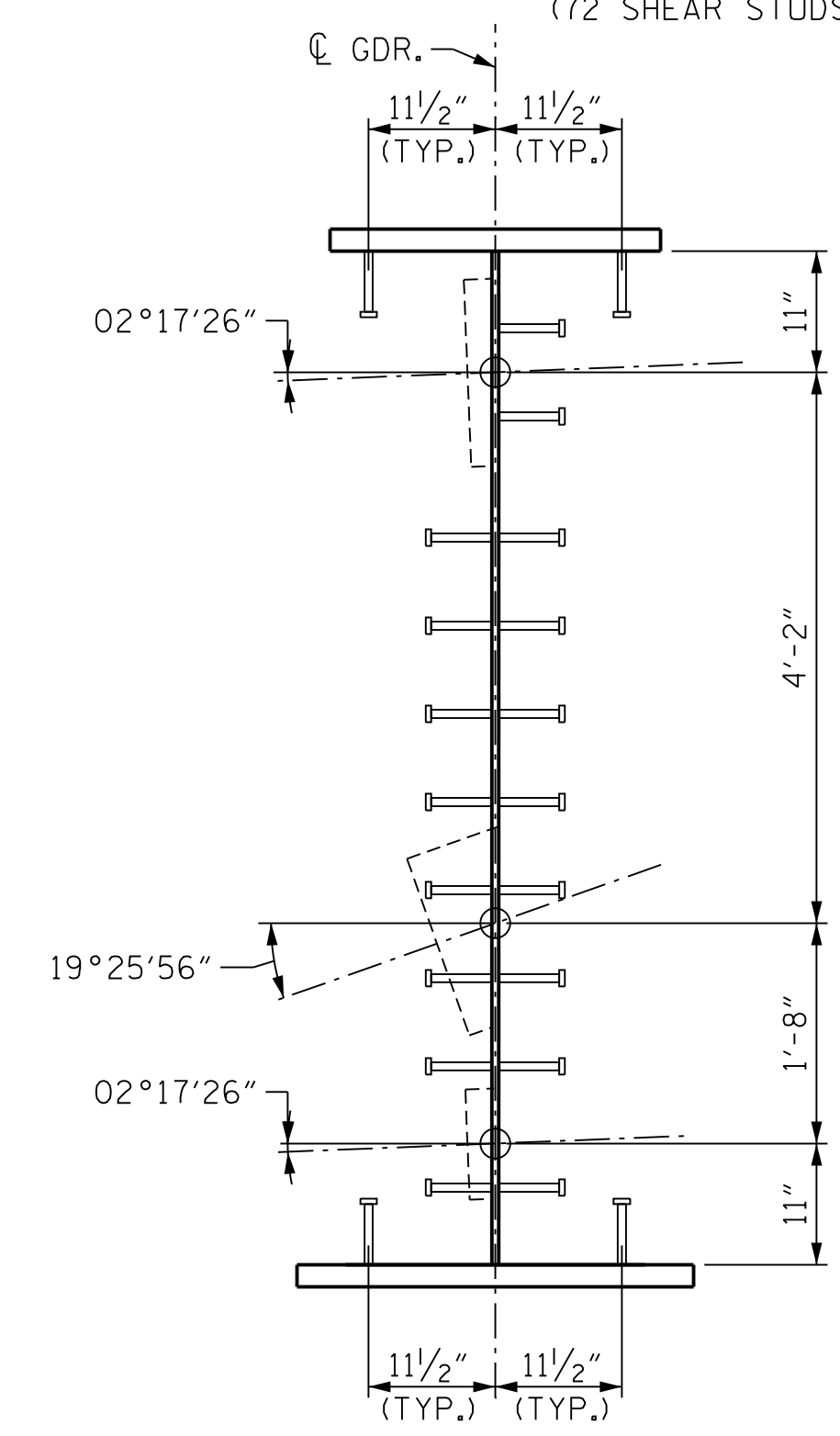

**GIRDER 1**

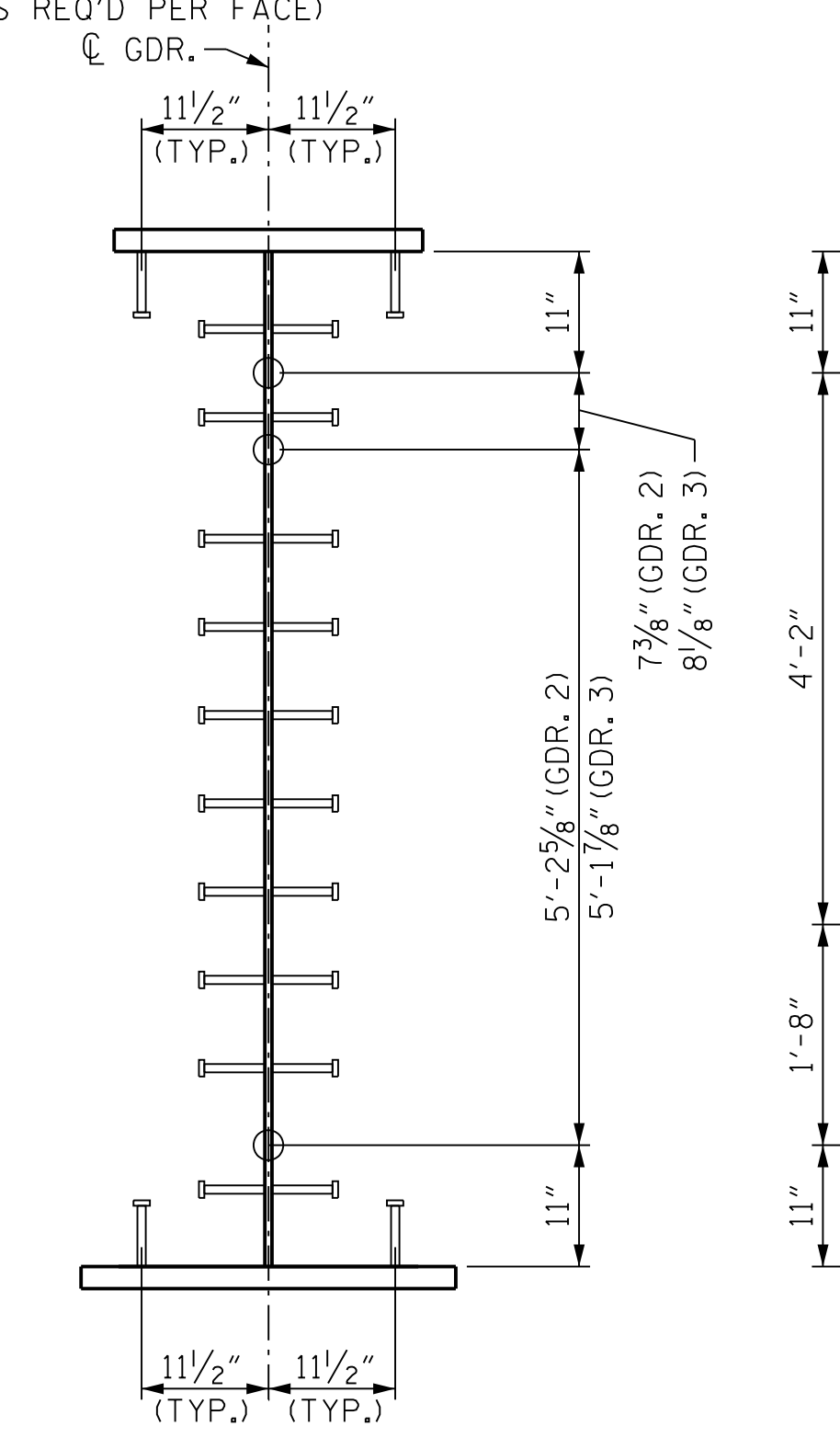

**GIRDERS 2 & 3**

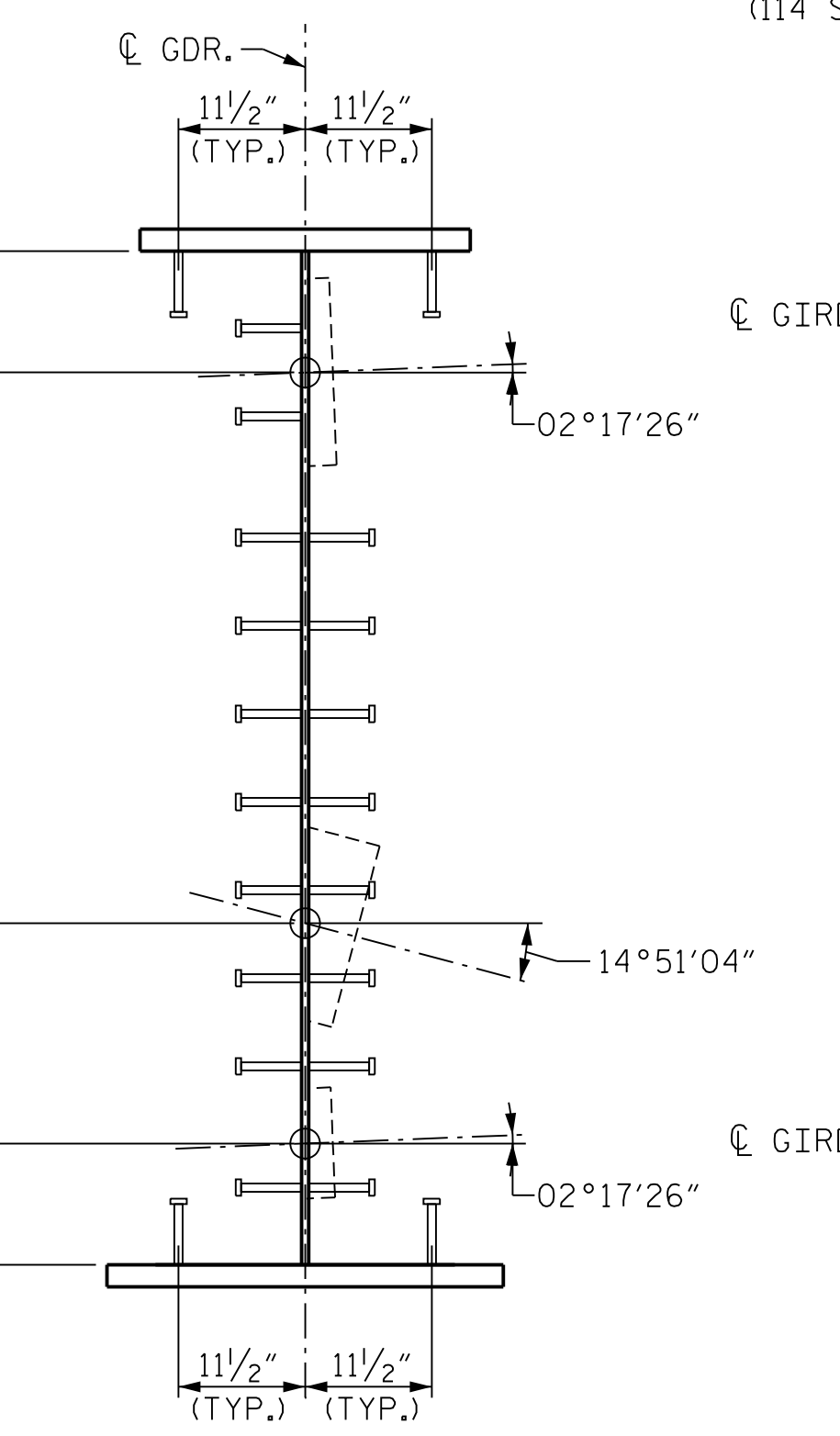

**GIRDER 4**

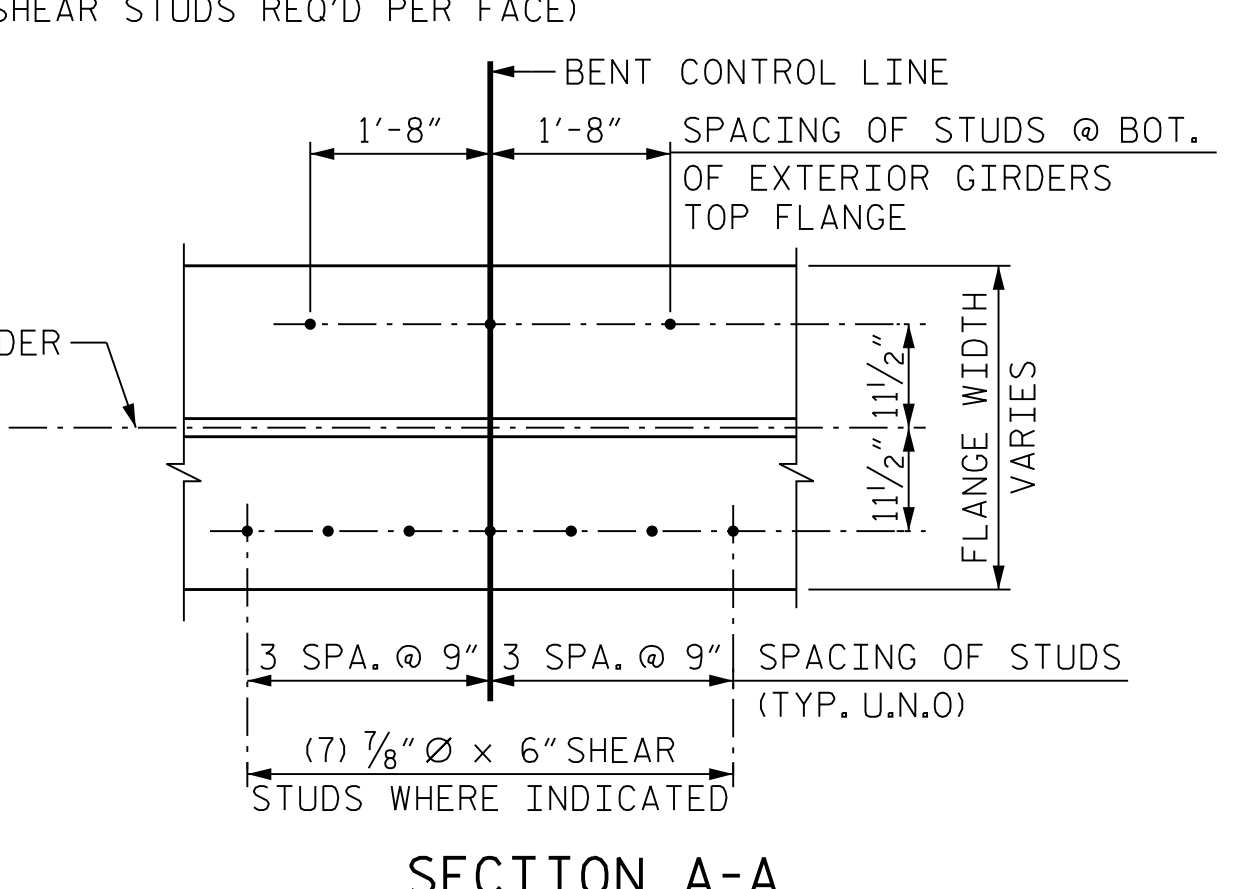

**SECTION A-A**

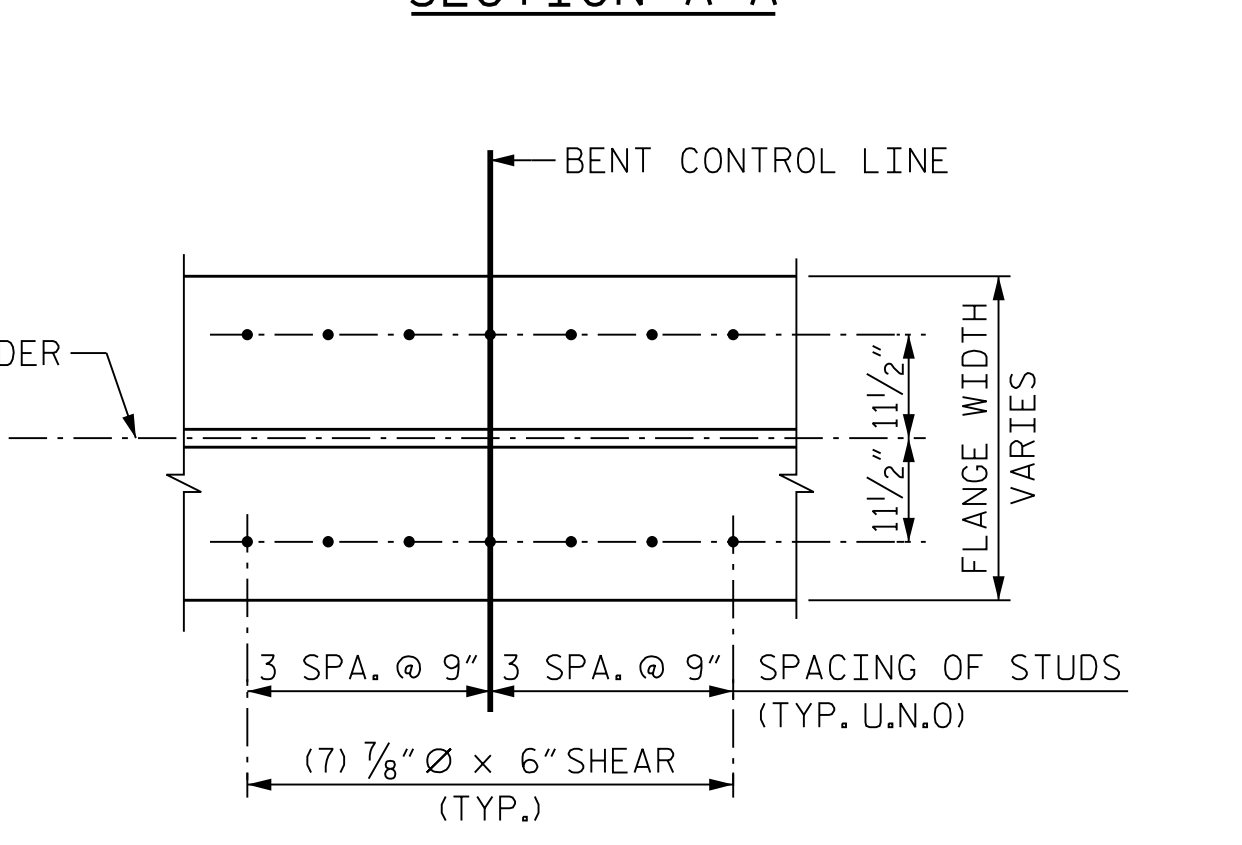

**SECTION B-B**

**NOTES**

- \* THE ITEMS LISTED BELOW SHALL BE VERIFIED BY THE POST-TENSIONING SUPPLIER PRIOR TO FABRICATION:
  - 1. SIZE, SHAPE & THICKNESS OF BEARING PLATE.
  - 2. DIAMETER OF THE BEARING PLATE HOLES.
  - 3. DIAMETER & LOCATION OF WEB HOLES.
- LOCATIONS OF SHEAR STUDS ON THE WEB MAY BE SHIFTED SLIGHTLY TO PROVIDE ADEQUATE CLEARANCE TO BEARING PLATES AND WEB HOLES, MAINTAINING A MINIMUM CLEAR DISTANCE OF 1/2" FROM ALL EDGES.
- PERMISSIBLE TO ADJUST SHEAR STUD LOCATIONS SLIGHTLY TO MAINTAIN 2" EDGE DISTANCE FROM HOLES PROVIDED IN GIRDER WEBS FOR POST-TENSIONING DUCT PENETRATIONS.
- SEE GIRDER ELEVATIONS FOR SPACING OF SHEAR STUDS ON TOP OF THE TOP FLANGE.
- FOR ADDITIONAL NOTES ON POST-TENSIONING AND ANCHORAGE, SEE "SCHEMATIC SEQUENCE OF CONSTRUCTION AND NOTES INTEGRAL BENTS 3" SHEET.
- HOLES IN WEB MAY NEED TO BE A GREATER DIAMETER TO ACCEPT BEARING PLATE TO TRUMPET WELD.

PROJECT NO. U-2579AB  
 FORSYTH COUNTY  
 STATION: 60+66.06 -Y15FLYAC-

SHEET 3 OF 3



10/15/2021

STATE OF NORTH CAROLINA  
 DEPARTMENT OF TRANSPORTATION  
 RALEIGH

**SUPERSTRUCTURE GIRDER DETAILS UNIT 1**

REVISIONS						SHEET NO.	
NO.	BY:	DATE:	NO.	BY:	DATE:	SHEET NO.	
1	--	--	3	--	--	TOTAL SHEETS	
2	--	--	4	--	--	144	

PLOT DRIVER: NCDOT\_pdf\_color\_eng-50.ppt  
 USER: PETERSON  
 DATE: 10/14/2021  
 TIME: 4:01:01 PM  
 FILE: ... \SUPERS

DES BY: S. JING	DATE: 11/19	DWG BY: B. PETERSON	DATE: 11/19
DES CHK: J. CABABE	DATE: 11/19	CHK BY: J. CABABE	DATE: 11/19

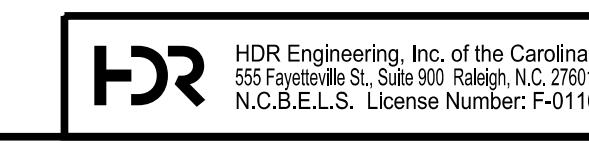

DOCUMENT NOT CONSIDERED FINAL UNLESS ALL SIGNATURES COMPLETED



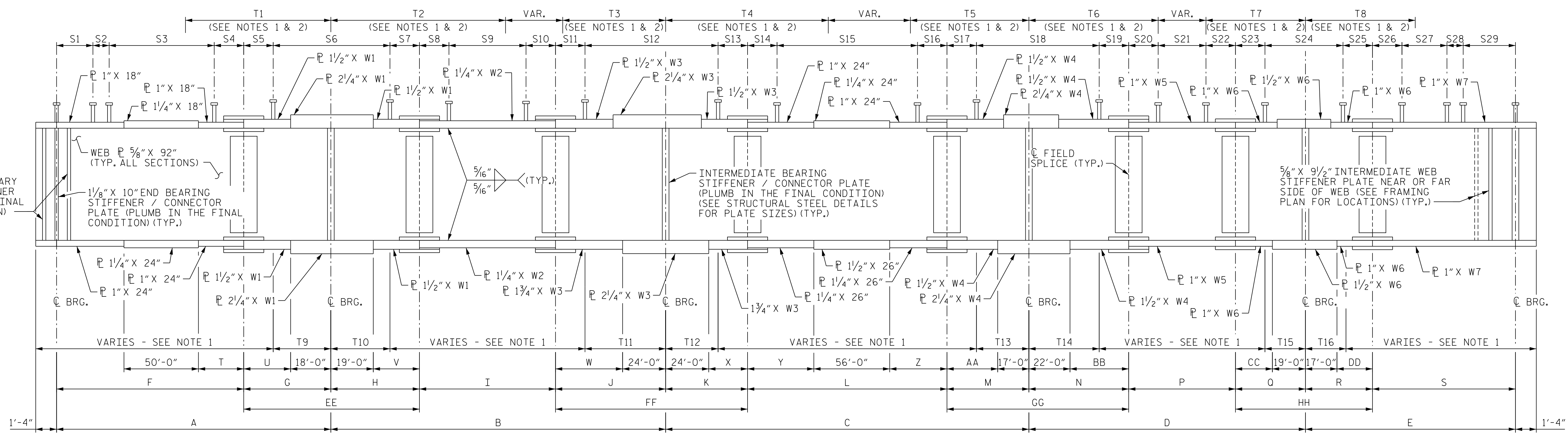

ELEVATION

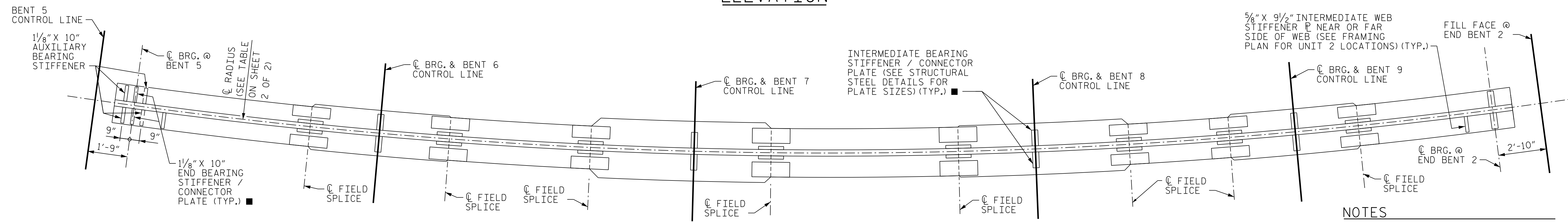

PLAN OF BOTTOM FLANGE

■ = SEE TABLE OF BEARING STIFFENERS ON "STRUCTURAL STEEL DETAILS" SHEET 1 OF 2.

- NOTES**
- SEE "SUPERSTRUCTURE GIRDER DETAILS - UNIT 1" SHEET 1 OF 3 FOR NOTES.
  - FOR DIMENSIONS, SEE SHEET 2 OF 2.
  - SEE SHEET "FRAMING PLAN - UNIT 2" FOR FIELD SPLICE TYPES.

PROJECT NO. U-2579AB  
 FORSYTH COUNTY  
 STATION: 60+66.06 -Y15FLYAC-  
 SHEET 1 OF 2

STATE OF NORTH CAROLINA  
 DEPARTMENT OF TRANSPORTATION  
 RALEIGH

**SUPERSTRUCTURE GIRDER DETAILS UNIT 2**

REVISIONS						SHEET NO.	
NO.	BY:	DATE:	NO.	BY:	DATE:	NO.	DATE:
1	--	--	3	--	--	TOTAL SHEETS	144
2	--	--	4	--	--		



10/15/2021

PLOT DRIVER: NCDOT...  
 USER: PETERSON...  
 DATE: 10/14/2021...  
 TIME: 4:01:09 PM

DES BY: T. ANDREWS	DATE: 07/19	DWG BY: B. PETERSON	DATE: 07/19
DES CHK: D. OLDS	DATE: 08/19	CHK BY: T. ANDREWS	DATE: 10/19

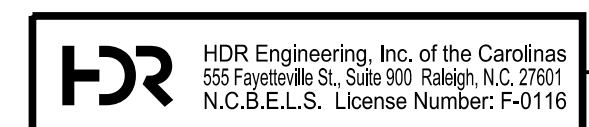

DOCUMENT NOT CONSIDERED FINAL UNLESS ALL SIGNATURES COMPLETED

PLOT DRIVER: NCDOT.pdf\_color\_eng-50.ppt  
USER: PPEIERSO DATE: 10/14/2021  
TIME: 4:01:17 PM  
FILE: ... \SUPERS

GIRDER DIMENSIONS

Table with 25 columns (GIRDER, C RADIUS, A, B, C, D, E, F, G, H, I, J, K, L, M, N, P, Q, R, S, T, U, V, W, X, Y, Z, AA) and 4 rows of data for girder dimensions.

STUD SPACING DIMENSIONS

Table with 22 columns (GIRDER, S1, S2, S3, S4, S5, S6, S7, S8, S9, S10, S11, S12, S13, S14, S15, S16, S17, S18, S19, S20) and 4 rows of data for stud spacing dimensions.

LIMITS OF TENSION FLANGES FOR CHARPY V-NOTCH TESTS

Table with 17 columns (GIRDER, T1, T2, T3, T4, T5, T6, T7, T8, T9, T10, T11, T12, T13, T14, T15, T16) and 4 rows of data for tension flange limits.

GIRDER FLANGE WIDTHS

Table with 9 columns (GIRDER, FLANGE, W1, W2, W3, W4, W5, W6, W7) and 4 rows of data for girder flange widths.

NOTE  
SEE "SUPERSTRUCTURE GIRDER DETAILS - UNIT 1"  
SHEET 1 OF 3 FOR NOTES.

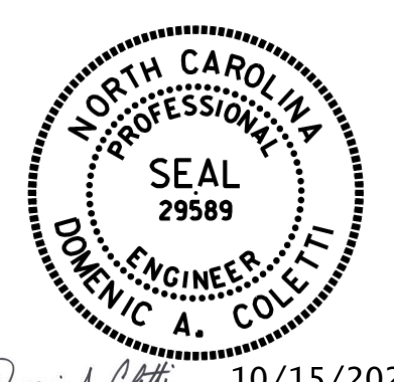

PROJECT NO. U-2579AB  
FORSYTH COUNTY  
STATION: 60+66.06 -Y15FLYAC-

DEPARTMENT OF TRANSPORTATION  
RALEIGH  
SUPERSTRUCTURE  
GIRDER DETAILS  
UNIT 2  
SHEET 2 OF 2  
REVISIONS table with columns NO., BY, DATE, NO., BY, DATE, SHEET NO., TOTAL SHEETS.

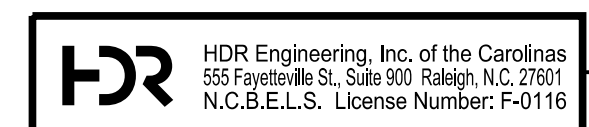

DOCUMENT NOT CONSIDERED FINAL  
UNLESS ALL SIGNATURES COMPLETED

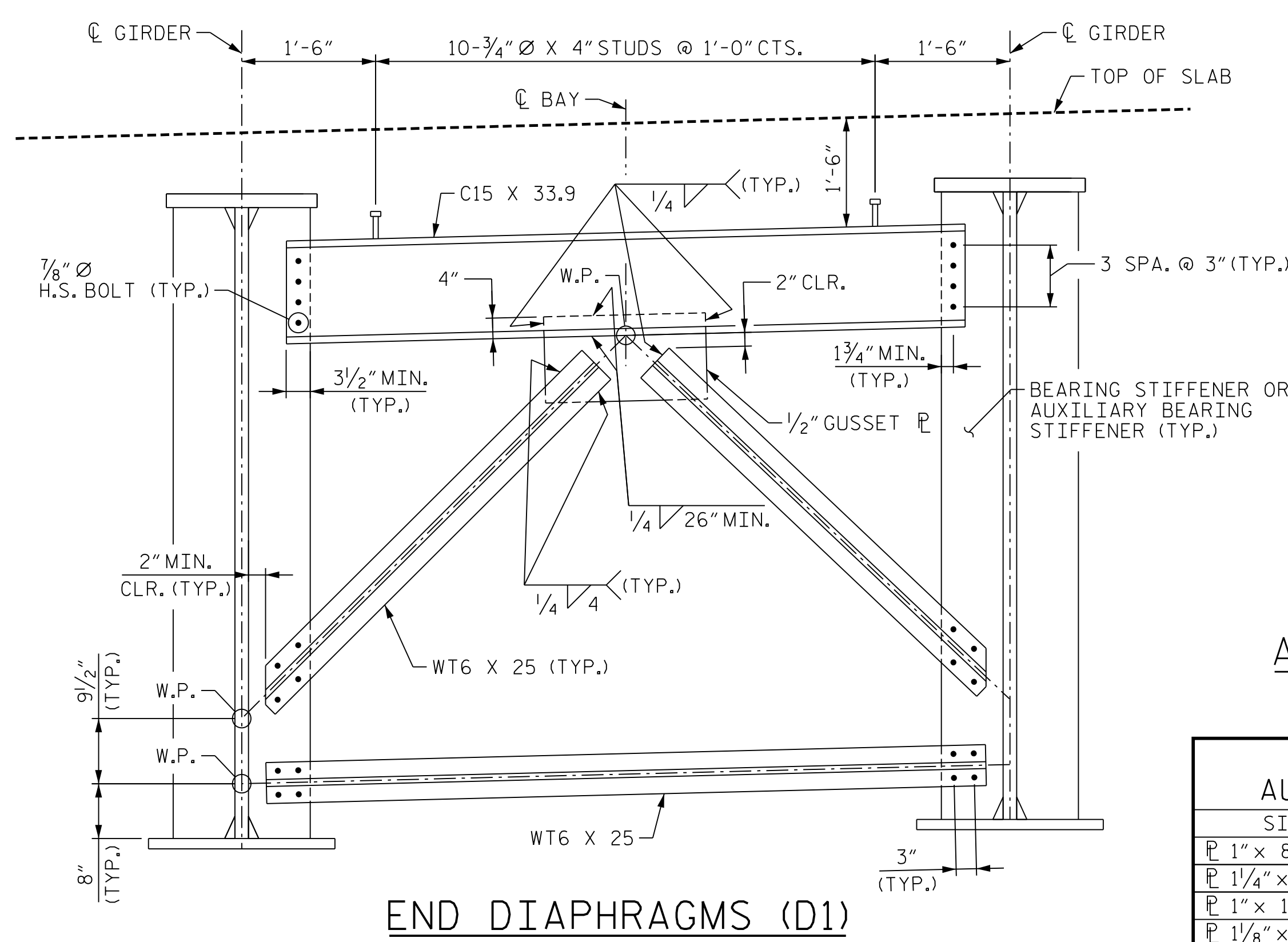

**END DIAPHRAGMS (D1)**

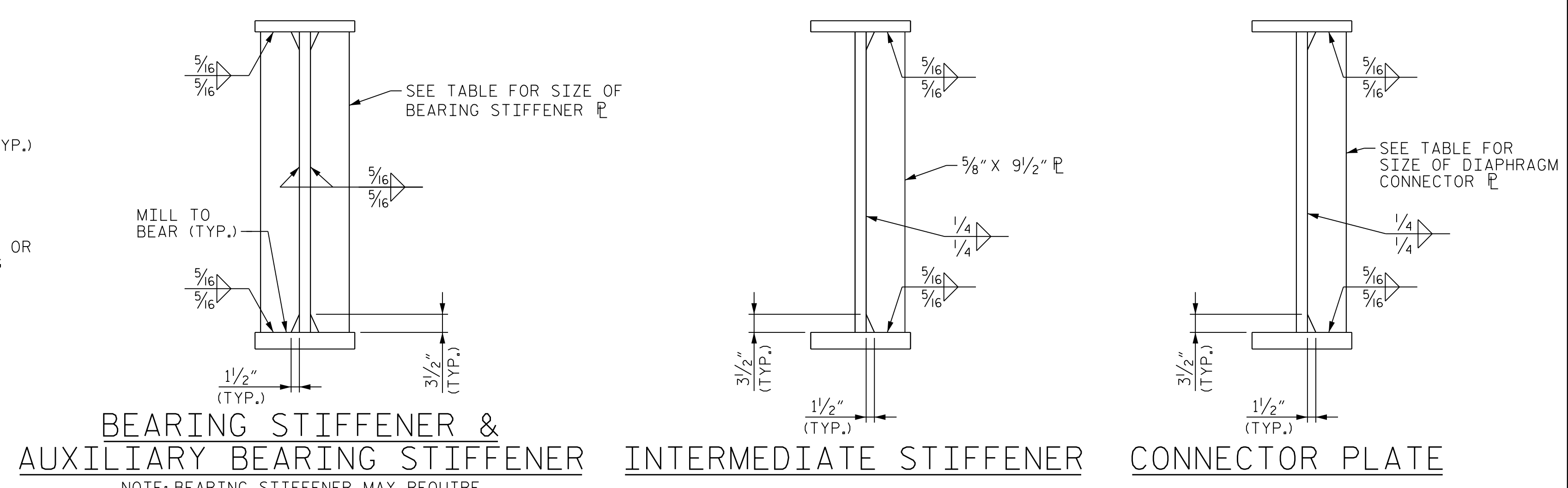

**BEARING STIFFENER & AUXILIARY BEARING STIFFENER**

**INTERMEDIATE STIFFENER**

**CONNECTOR PLATE**

NOTE: BEARING STIFFENER MAY REQUIRE COPING IF WIDER THAN BOT. FLANGE

BEARING STIFFENERS & AUXILIARY BEARING STIFFENERS	
SIZE	LOCATIONS *
P 1" x 8 1/2"	END BENT 1, BENT 1
P 1 1/4" x 11 1/2"	BENTS 2 & 4
P 1" x 10 1/2"	BENT 5 BK
P 1 1/8" x 10"	BENT 5 AH, BENTS 6 & 9, END BENT 2
P 1 3/8" x 15"	BENT 7
P 1 1/4" x 13"	BENT 8

DIAPHRAGM CONNECTOR PLATES	
MAXIMUM FLANGE PLATE WIDTH	MIN. SIZE
≤ 34"	5/8" x 8 1/2"
36" & 38"	5/8" x 9 1/2"

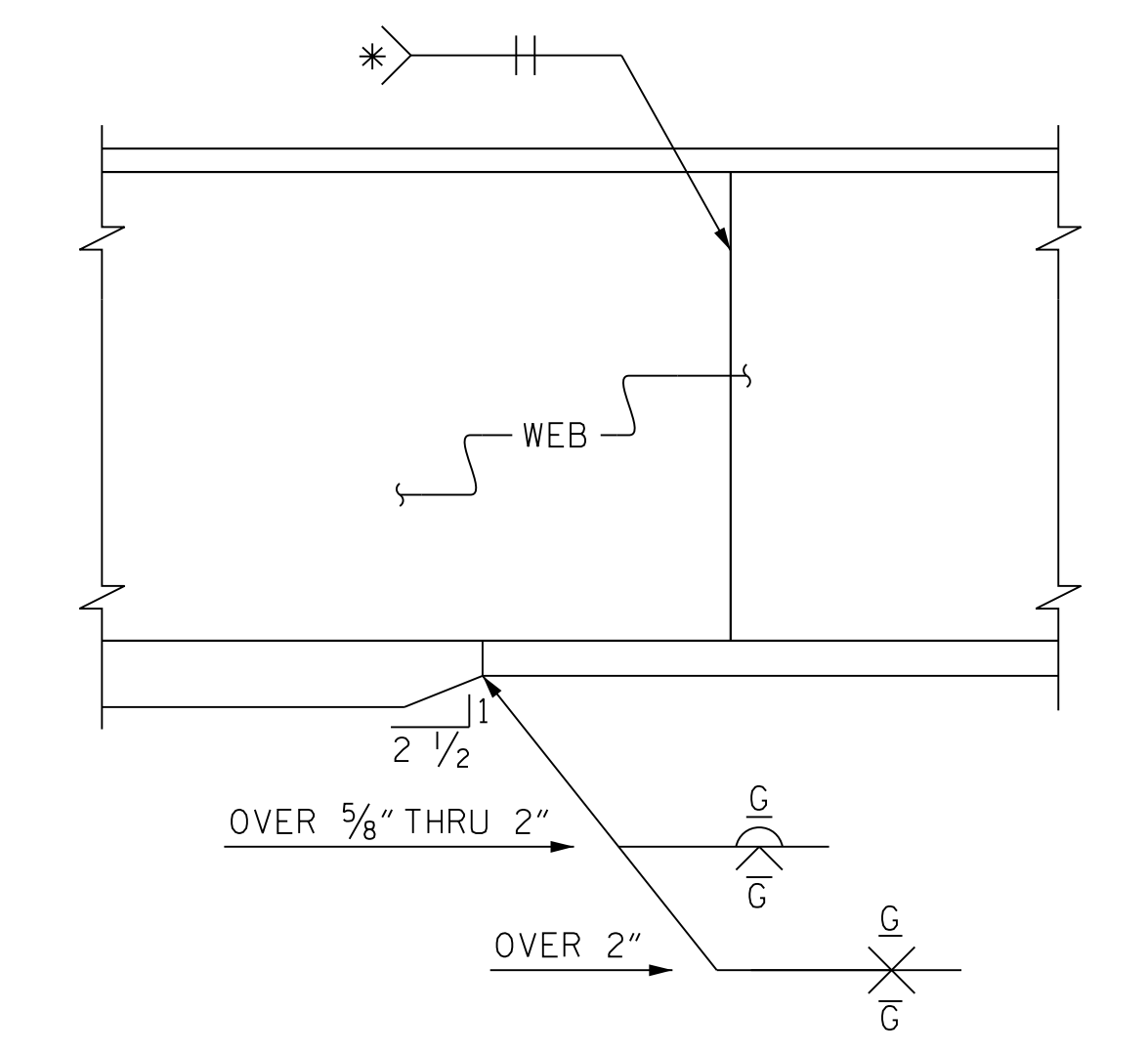

**TYPICAL FLANGE AND WEB BUTT JOINT SHOP SPLICE DETAILS**

\* GRIND SMOOTH AND FLUSH ON OUTER FACE OF EXTERIOR BEAMS/ GIRDERS.

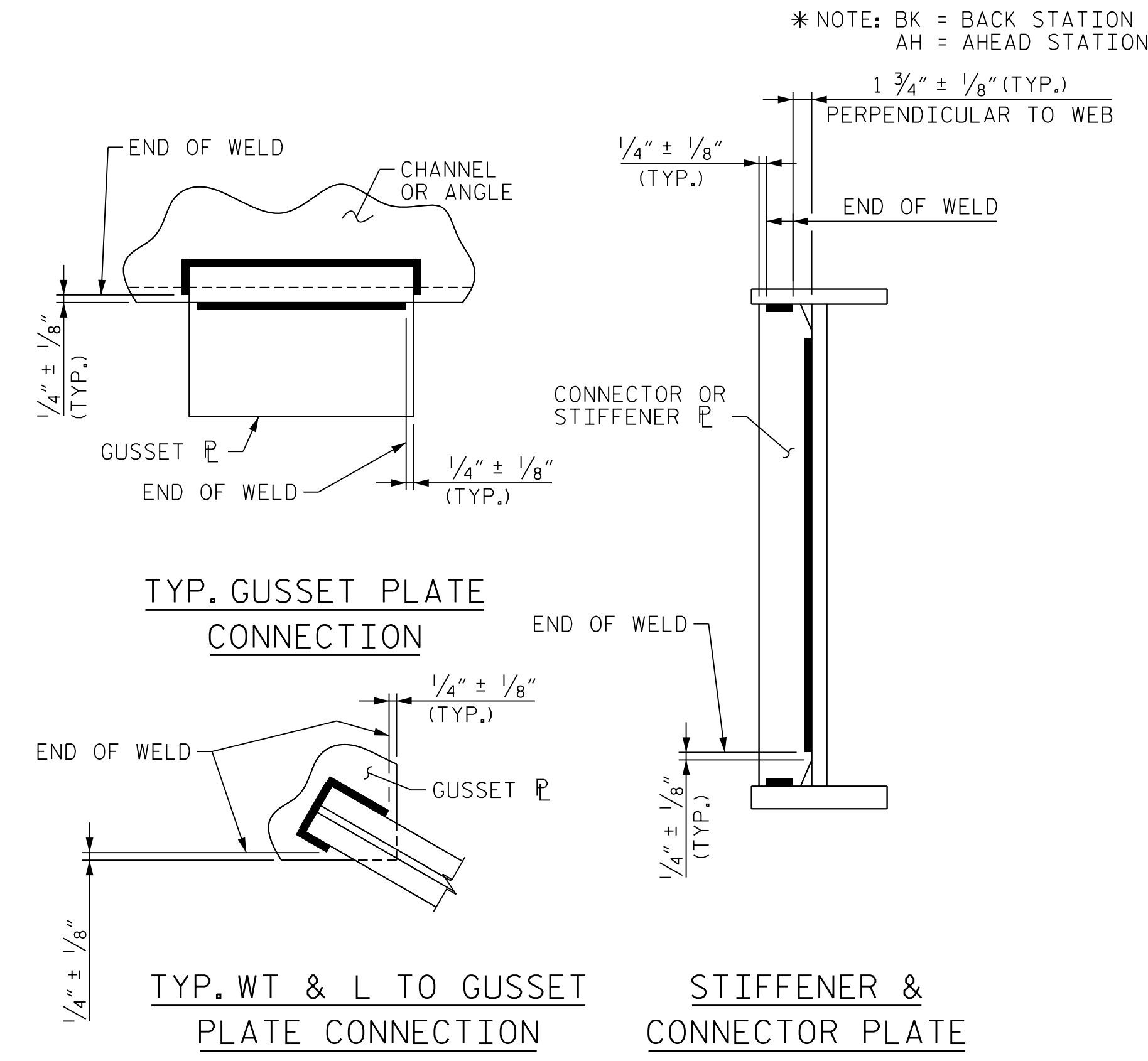

**WELD TERMINATION DETAILS**

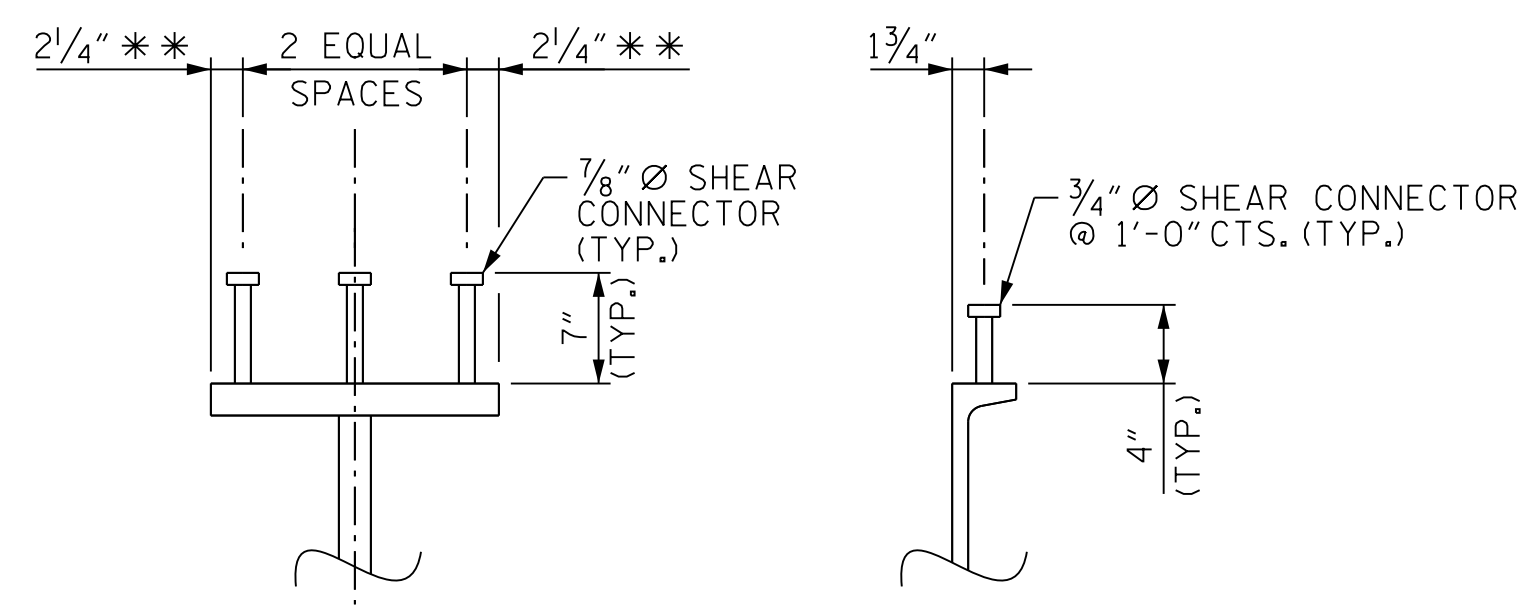

**GIRDER SHEAR CONNECTORS**  
**DIAPHRAGM SHEAR CONNECTORS**  
**SHEAR CONNECTOR DETAILS**

\*\* FOR SPACING OF SHEAR CONNECTORS ON TOP PLATE OF FIELD SPLICES, SEE "SUPERSTRUCTURE BOLTED FIELD SPLICE DETAILS" SHEETS.

PROJECT NO. U-2579AB  
FORSYTH COUNTY  
 STATION: 60+66.06 -Y15FLYAC-

SHEET 1 OF 2

STATE OF NORTH CAROLINA  
 DEPARTMENT OF TRANSPORTATION  
 RALEIGH

**SUPERSTRUCTURE STRUCTURAL STEEL DETAILS**



10/15/2021

REVISIONS						SHEET NO. S04-039 TOTAL SHEETS 144
NO.	BY:	DATE:	NO.	BY:	DATE:	
1	--	--	3	--	--	
2	--	--	4	--	--	



DOCUMENT NOT CONSIDERED FINAL UNLESS ALL SIGNATURES COMPLETED

PLOT DRIVER: NCDOT\_pdf\_color\_eng-50.ppt  
 USER: PETERSON DATE: 10/14/2021  
 FILE: ... \SUPERS

DES BY: <u>G. SCHMITZ</u>	DATE: <u>07/19</u>	DWG BY: <u>B. PETERSON</u>	DATE: <u>07/19</u>
DES CHK: <u>D. COLETTI</u>	DATE: <u>08/19</u>	CHK BY: <u>G. SCHMITZ</u>	DATE: <u>10/19</u>

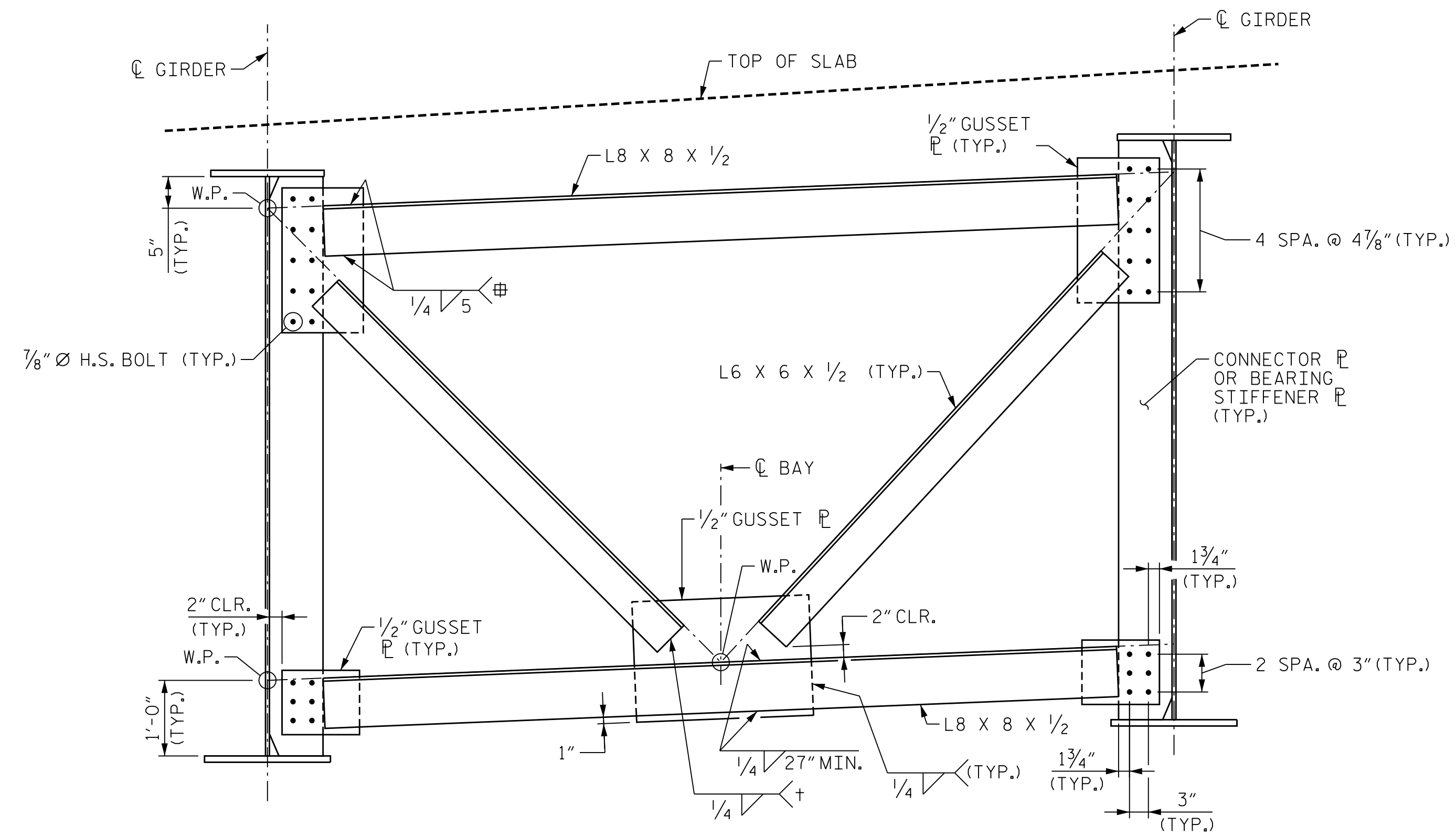

**INTERMEDIATE DIAPHRAGMS AND BENT DIAPHRAGMS (D2)**

⊕ = TYP. ALONG SIDES OF ALL ANGLES  
 † = TYP. @ ENDS OF ALL ANGLES

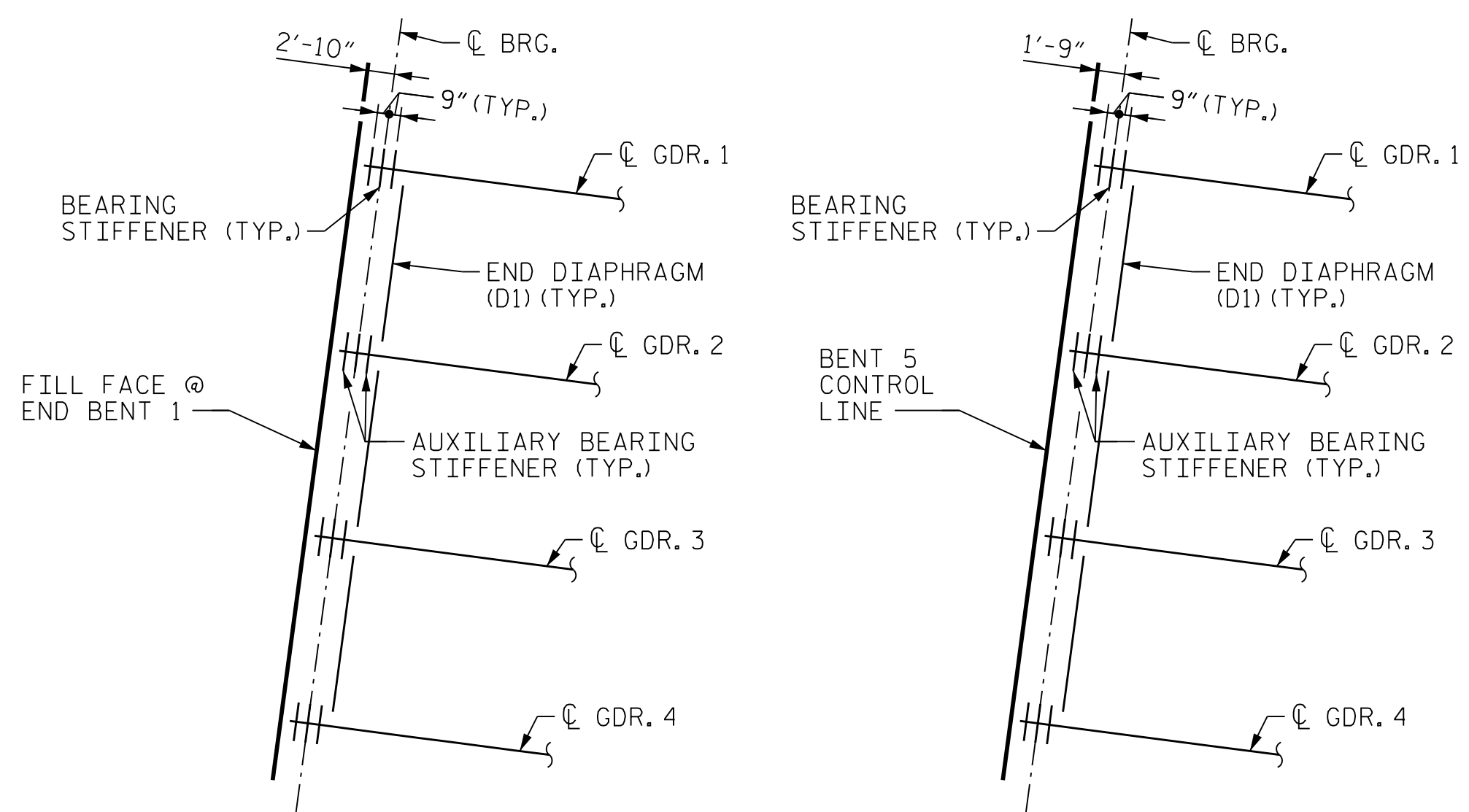

**UNIT 1 END BENT 1      UNIT 2 BENT 5**  
**AUXILIARY BEARING STIFFENER DETAIL**

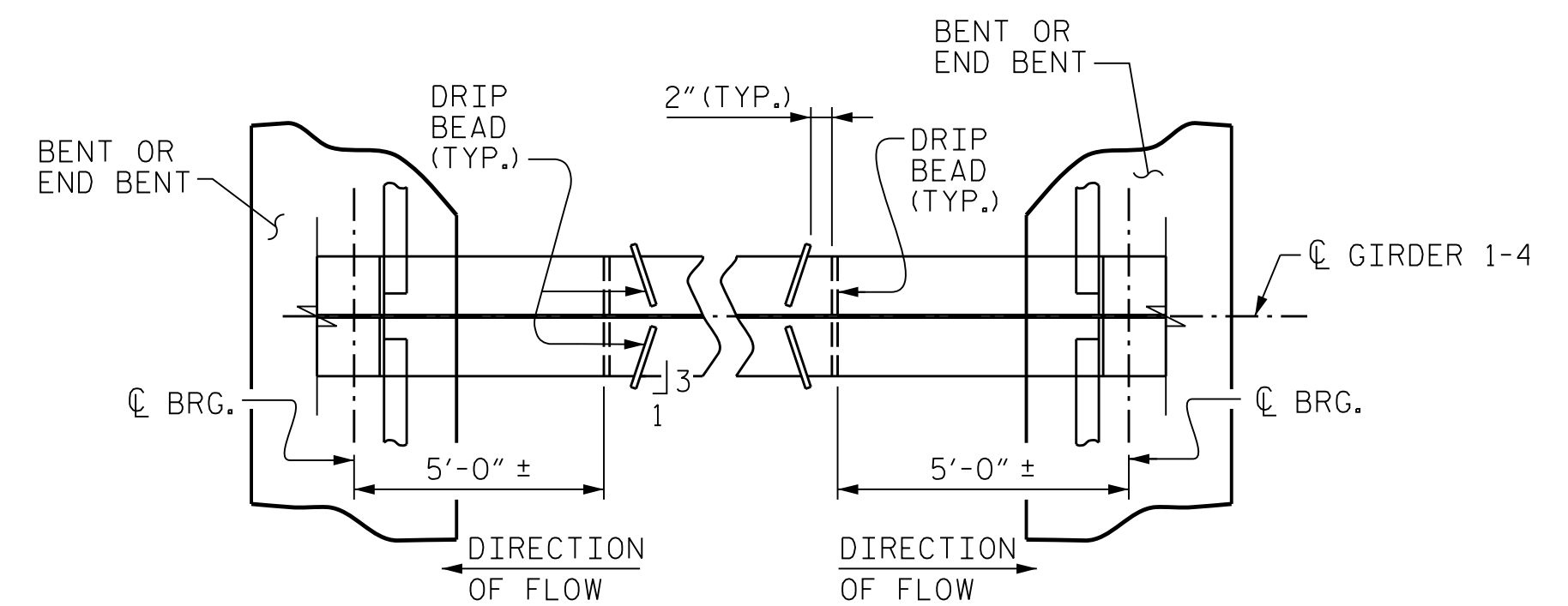

**PART PLAN - BOTTOM FLANGE**

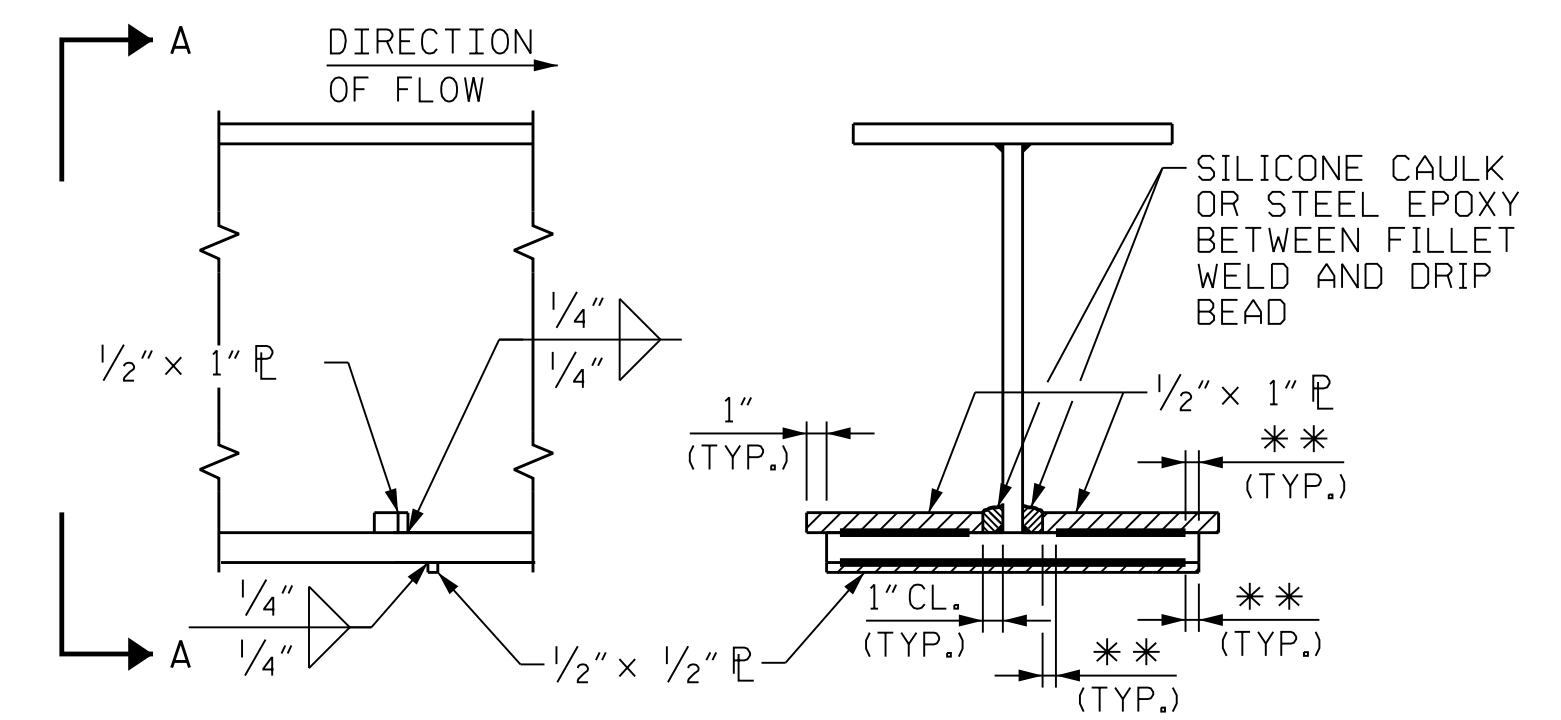

**SECTION**

**VIEW A-A**

\*\* SEE "WELD TERMINATION DETAILS"

**DRIP BEAD DETAILS**

PROJECT NO. U-2579AB  
 FORSYTH COUNTY  
 STATION: 60+66.06 -Y15FLYAC-

SHEET 2 OF 2

STATE OF NORTH CAROLINA  
 DEPARTMENT OF TRANSPORTATION  
 RALEIGH

**SUPERSTRUCTURE  
 STRUCTURAL STEEL  
 DETAILS**



10/15/2021

DES BY: G. SCHMITZ	DATE: 07/19	DWG BY: B. PETERSON	DATE: 07/19
DES CHK: D. COLETTI	DATE: 08/19	CHK BY: G. SCHMITZ	DATE: 10/19

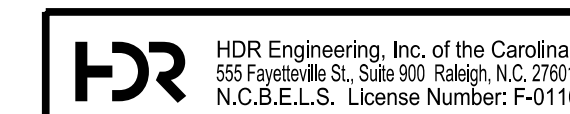

DOCUMENT NOT CONSIDERED FINAL  
 UNLESS ALL SIGNATURES COMPLETED

REVISIONS						SHEET NO. SD4-040 TOTAL SHEETS 144
NO.	BY:	DATE:	NO.	BY:	DATE:	
1	--	--	3	--	--	
2	--	--	4	--	--	

PLOT DRIVER: NCDOT\_pdf\_color\_eng-50dpi  
 USER: PPETERSO  
 DATE: 10/14/2021  
 TIME: 4:01:33 PM  
 FILE: ... \SUPERS

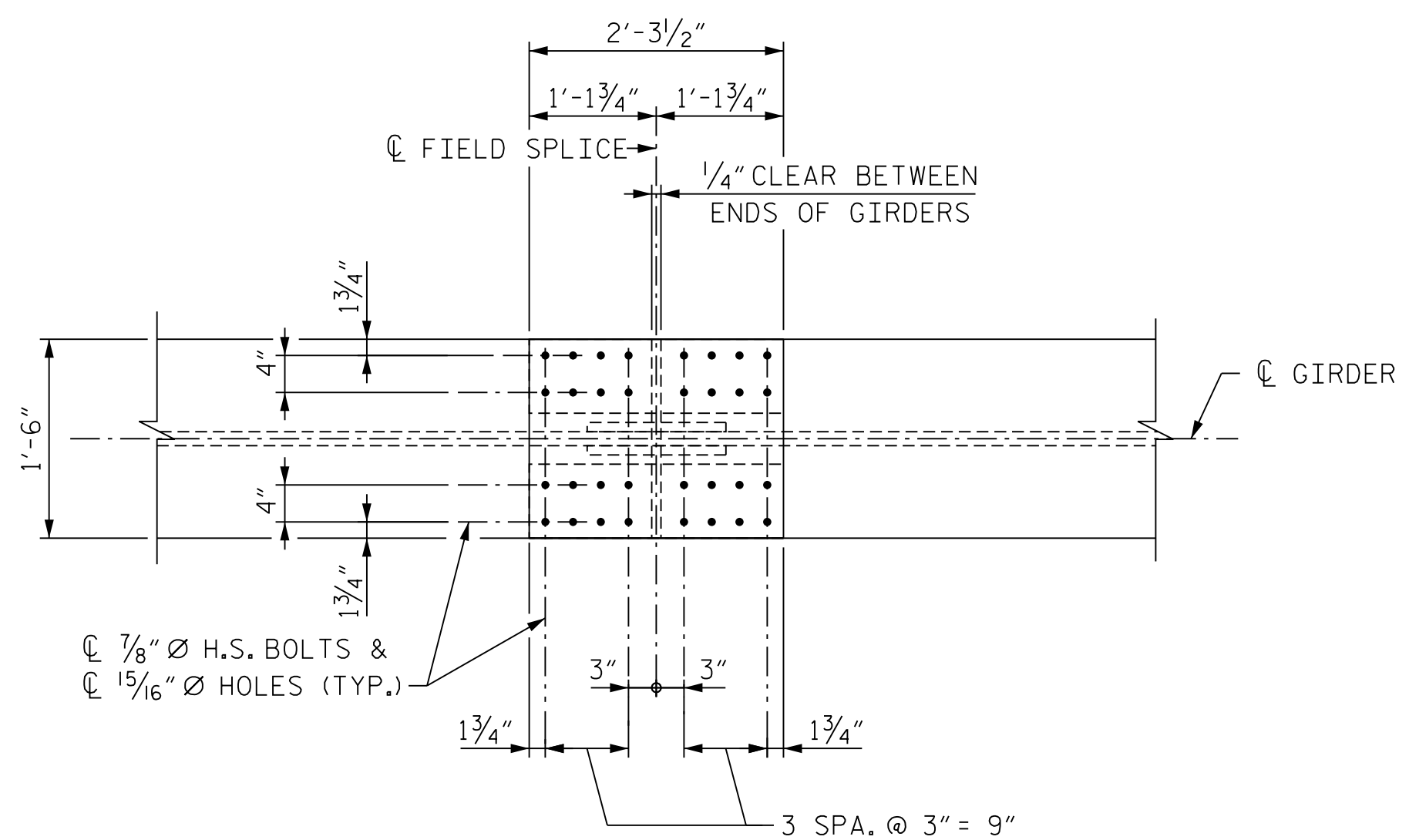

**PLAN (TOP OF TOP FLANGE)**

(STUDS NOT SHOWN FOR CLARITY)

\* = SHEAR STUDS ARE TO BE SHOP WELDED ON TOP OF PLATE BEFORE FIELD ASSEMBLY

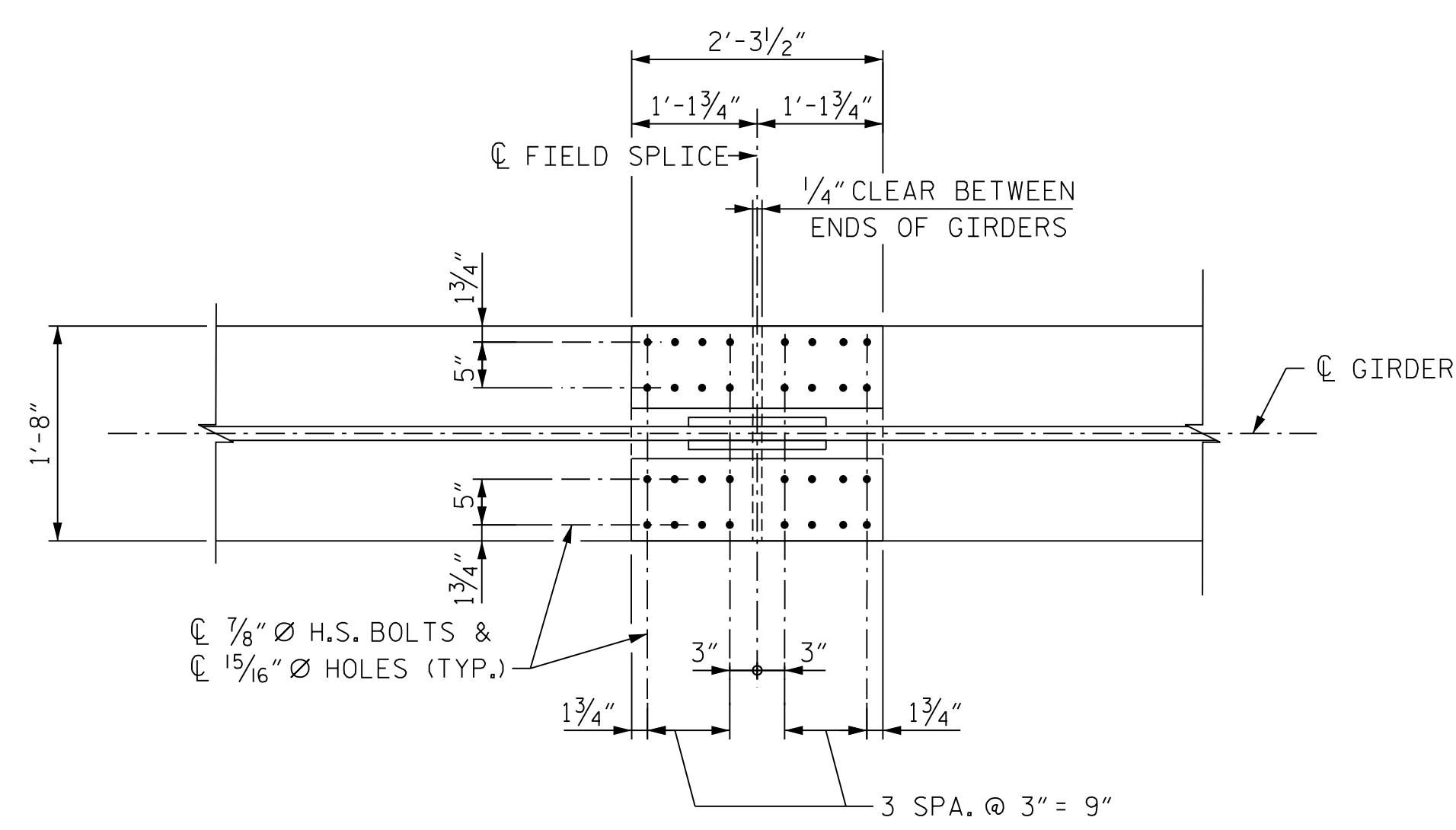

**PLAN (TOP OF BOTTOM FLANGE)**

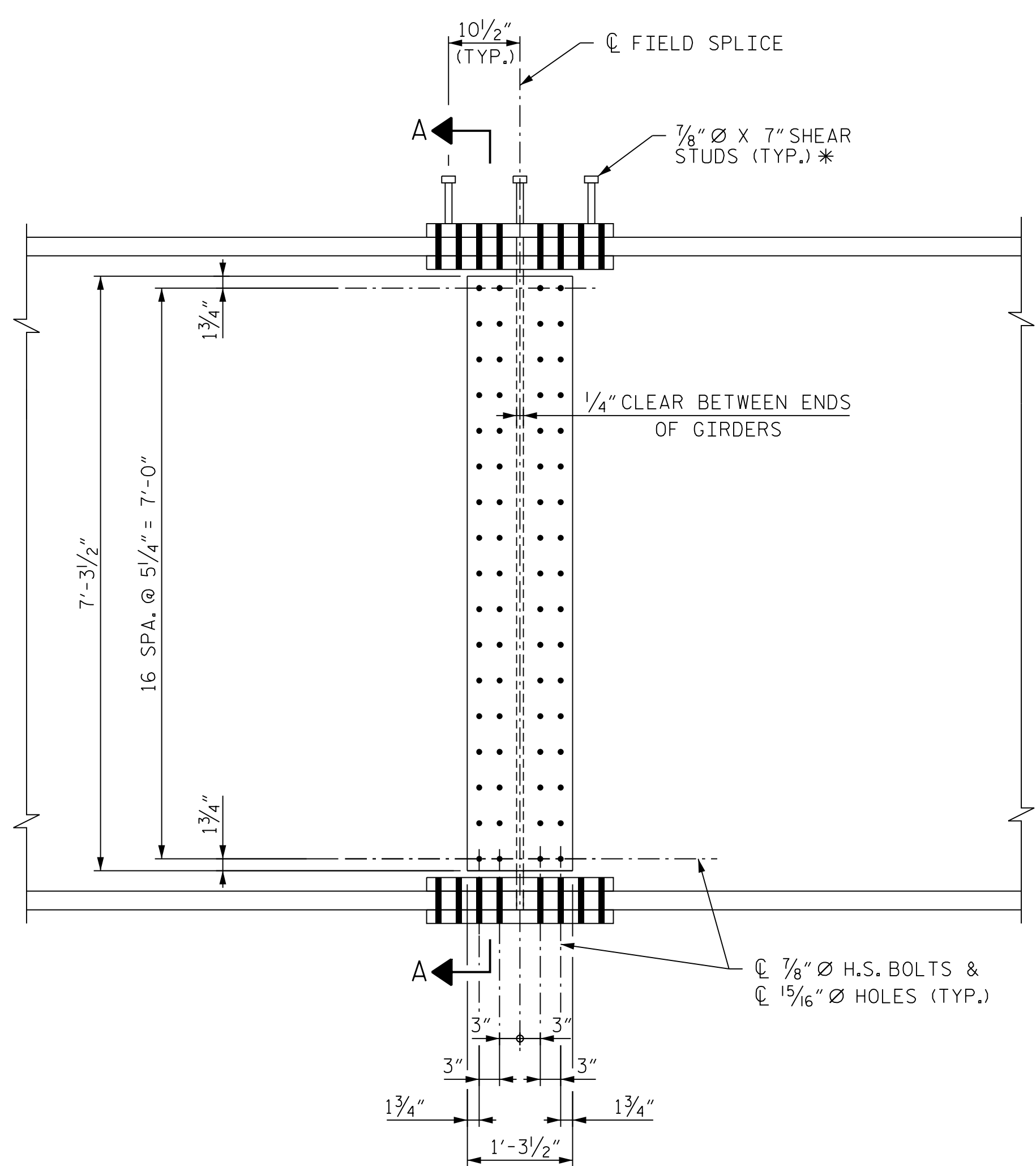

**ELEVATION**

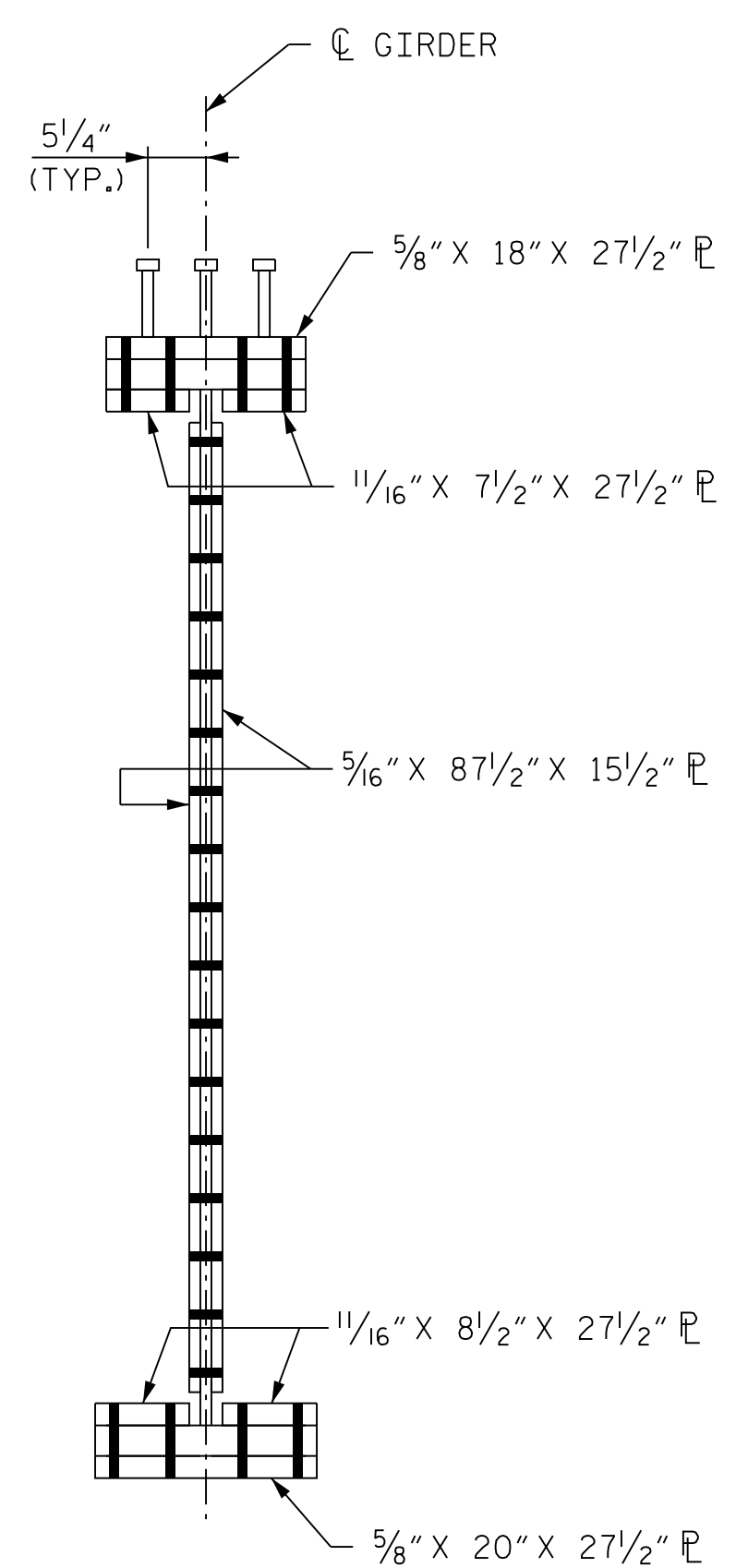

**SECTION A-A**

**NOTE**

ORIENTATION OF PLAN AND ELEVATION VIEWS MAY VARY BASED ON FIELD SPLICE LOCATION

PROJECT NO. U-2579AB  
FORSYTH COUNTY  
 STATION: 60+66.06 -Y15FLYAC-

SHEET 1 OF 19

STATE OF NORTH CAROLINA  
 DEPARTMENT OF TRANSPORTATION  
 RALEIGH

**SUPERSTRUCTURE  
 BOLTED FIELD SPLICE  
 DETAILS - TYPE "A"**



*Dominic A. Colletti* 10/15/2021

**REVISIONS**

NO.	BY:	DATE:	NO.	BY:	DATE:
1	--	--	3	--	--
2	--	--	4	--	--

SHEET NO.  
S04-041  
 TOTAL SHEETS  
 144



**DOCUMENT NOT CONSIDERED FINAL  
 UNLESS ALL SIGNATURES COMPLETED**

PLOT DRIVER: NCDOT\_pdf\_color\_eng\_50dpi  
 USER: PPETERSO DATE: 10/14/2021  
 FILE: ... \SUPERS

DES BY: <u>G. SCHMITZ</u>	DATE: <u>07/19</u>	DWG BY: <u>B. PETERSON</u>	DATE: <u>07/19</u>
DES CHK: <u>D. OLDS</u>	DATE: <u>08/19</u>	CHK BY: <u>T. ANDREWS</u>	DATE: <u>10/19</u>

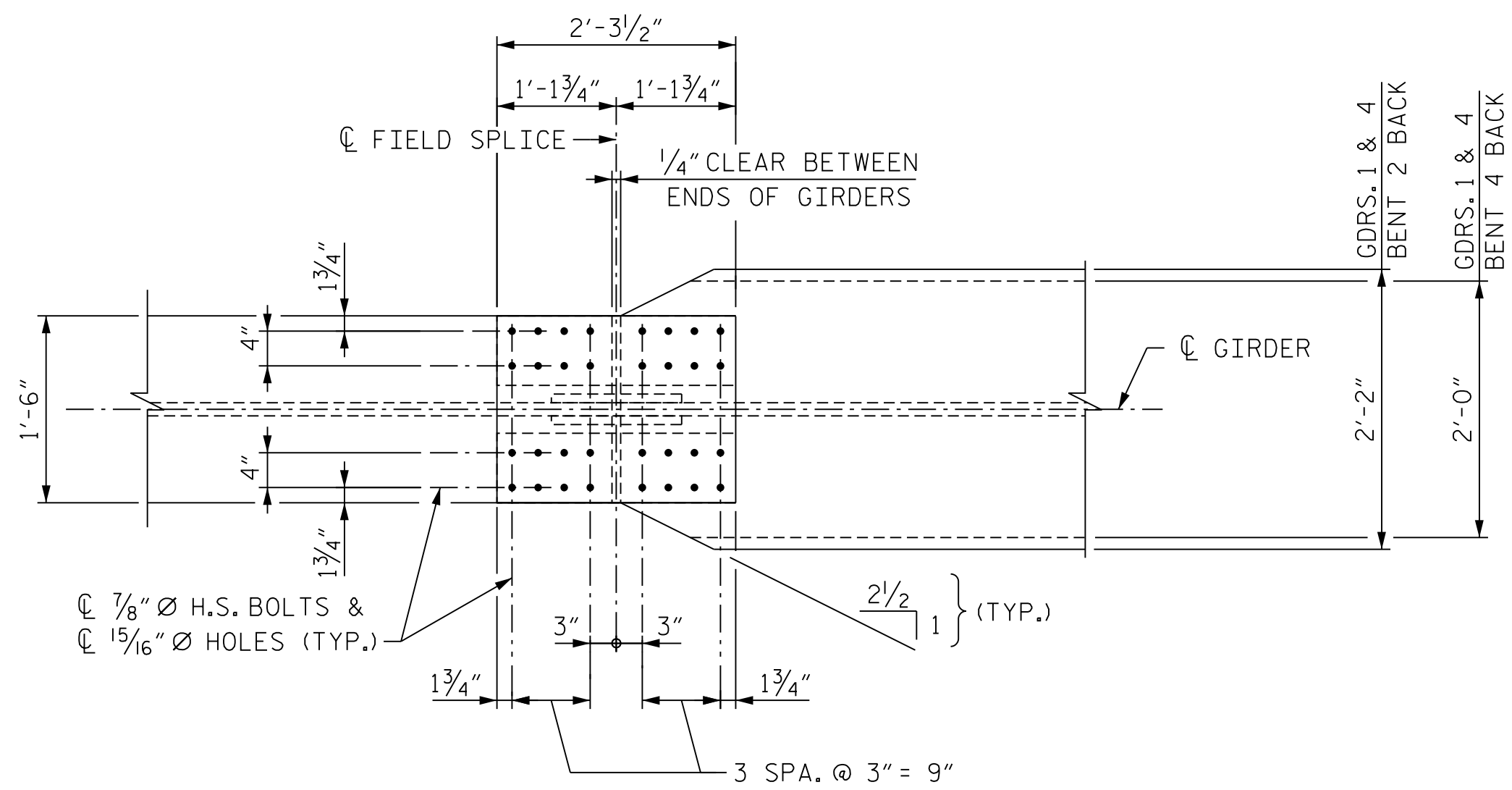

PLAN (TOP OF TOP FLANGE)

(STUDS NOT SHOWN FOR CLARITY)

\* = SHEAR STUDS ARE TO BE SHOP WELDED ON TOP OF PLATE BEFORE FIELD ASSEMBLY

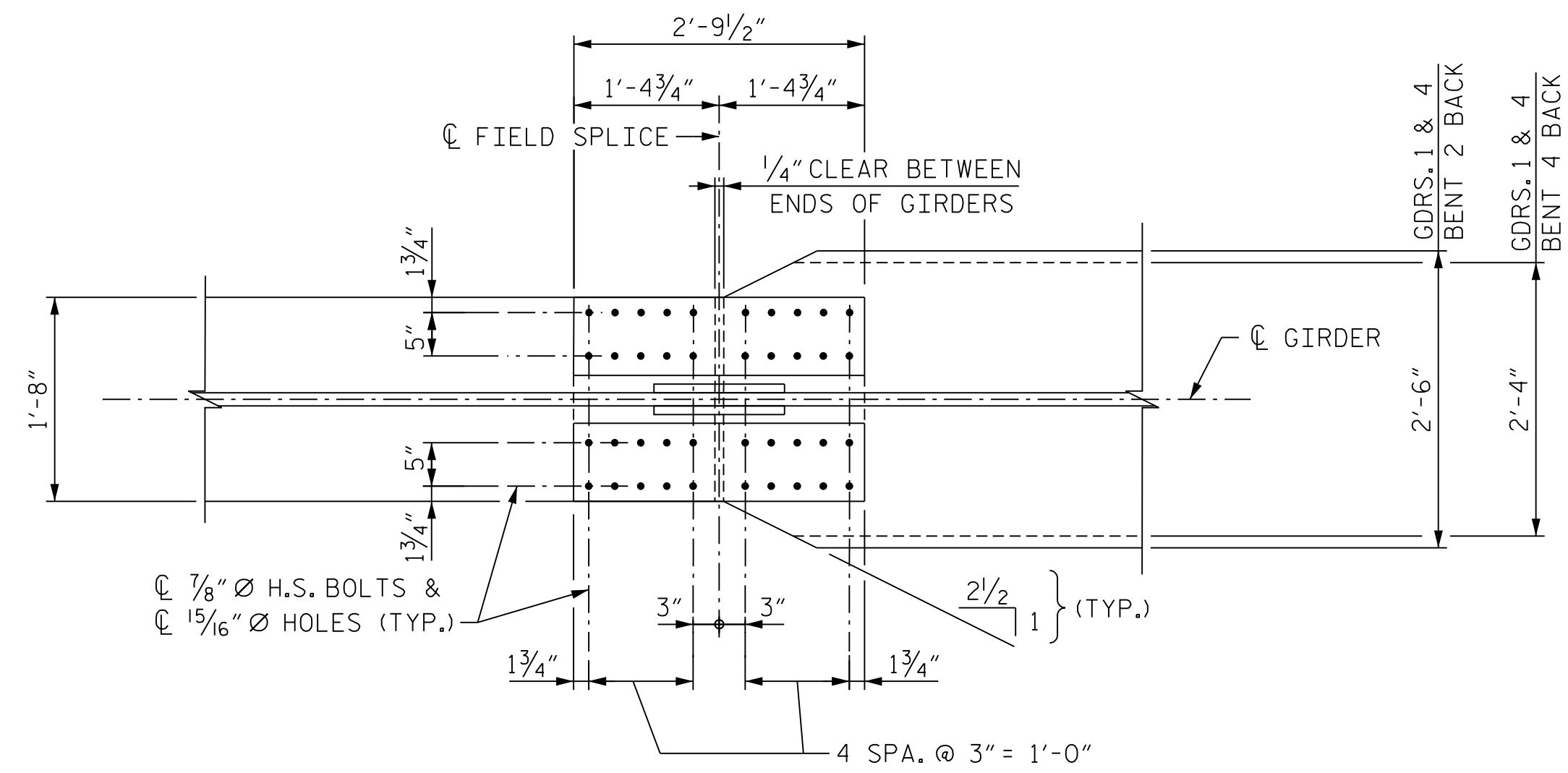

PLAN (TOP OF BOTTOM FLANGE)

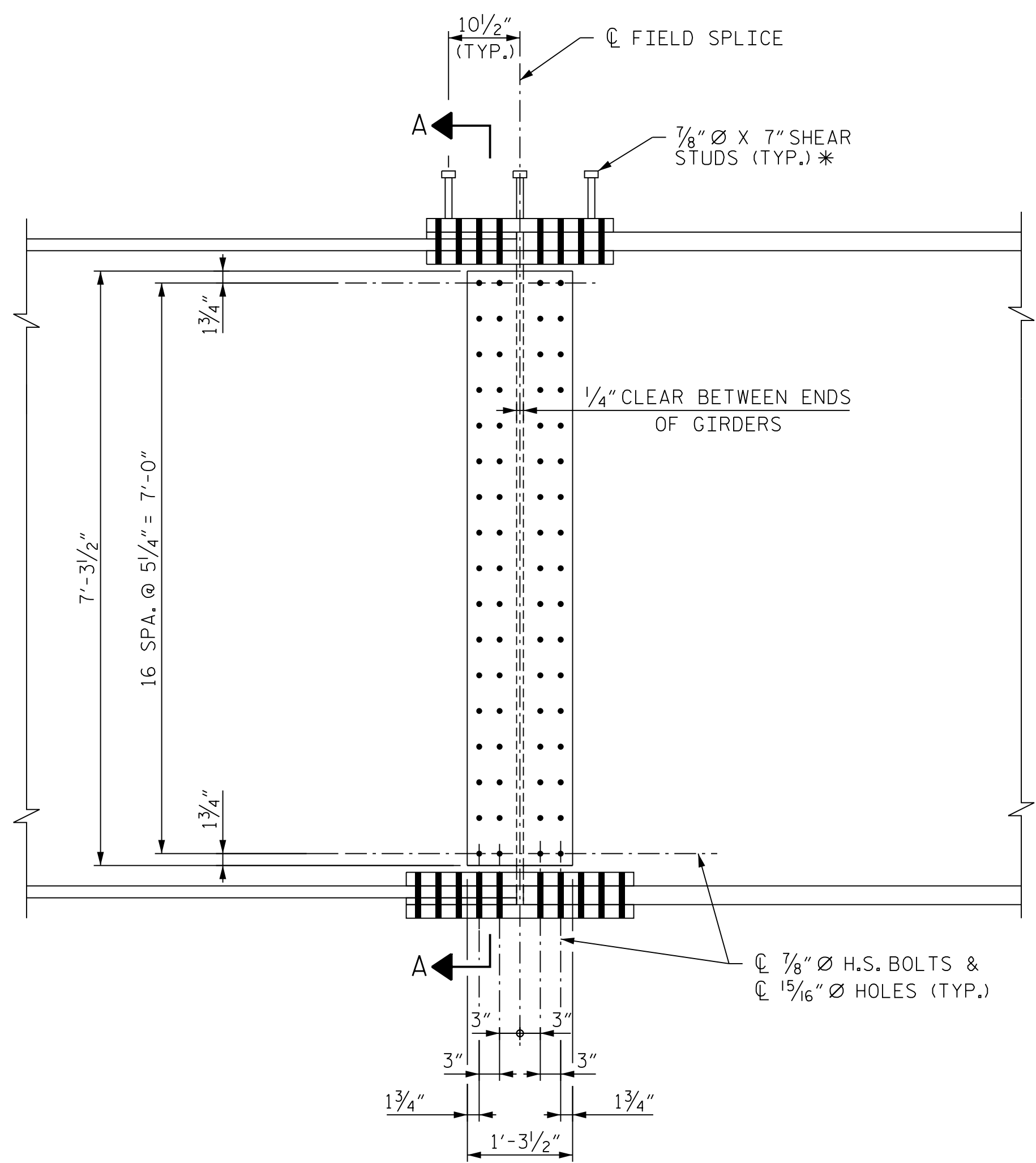

ELEVATION

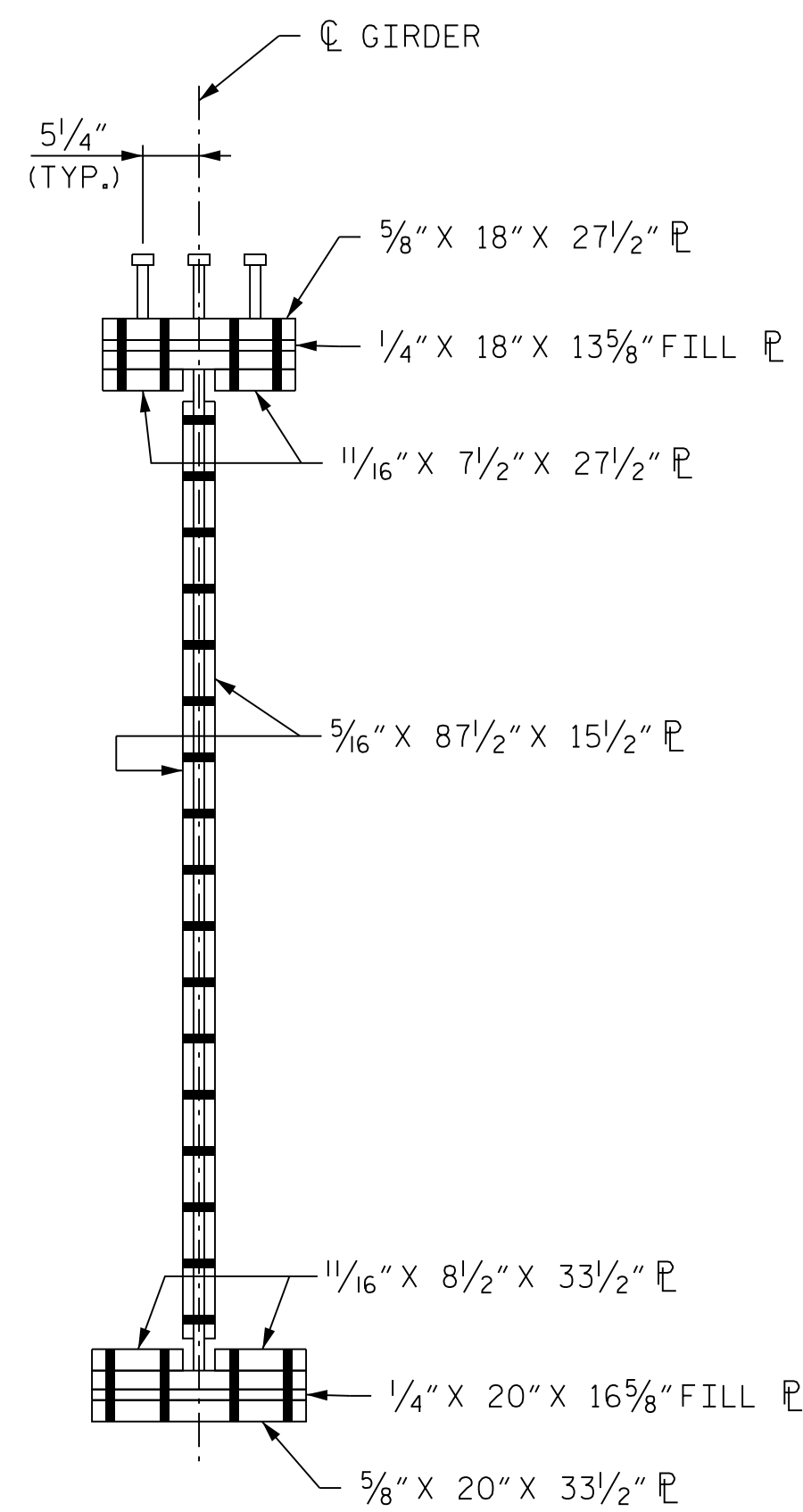

SECTION A-A

NOTE  
ORIENTATION OF PLAN AND ELEVATION VIEWS MAY VARY BASED ON FIELD SPLICE LOCATION

PROJECT NO. U-2579AB  
FORSYTH COUNTY  
 STATION: 60+66.06 -Y15FLYAC-

SHEET 2 OF 19

STATE OF NORTH CAROLINA  
 DEPARTMENT OF TRANSPORTATION  
 RALEIGH

SUPERSTRUCTURE  
 BOLTED FIELD SPLICE  
 DETAILS - TYPE "B"



10/15/2021

REVISIONS

NO.	BY:	DATE:	NO.	BY:	DATE:
1	--	--	3	--	--
2	--	--	4	--	--

SHEET NO. S04-042  
 TOTAL SHEETS 144



HDR Engineering, Inc. of the Carolinas  
 555 Fayetteville St., Suite 900 Raleigh, N.C. 27601  
 N.C.B.E.L.S. License Number: F-0116

DOCUMENT NOT CONSIDERED FINAL  
 UNLESS ALL SIGNATURES COMPLETED

PLOT DRIVER: NCDOT... PENTABLE: NCDOT STRUCTURES DEFAULT PEN.tbl  
 USER: PPETERSO DATE: 10/14/2021  
 FILE: ... \SUPERS

DES BY: G. SCHMITZ	DATE: 07/19	DWG BY: B. PETERSON	DATE: 07/19
DES CHK: D. OLDS	DATE: 08/19	CHK BY: T. ANDREWS	DATE: 10/19

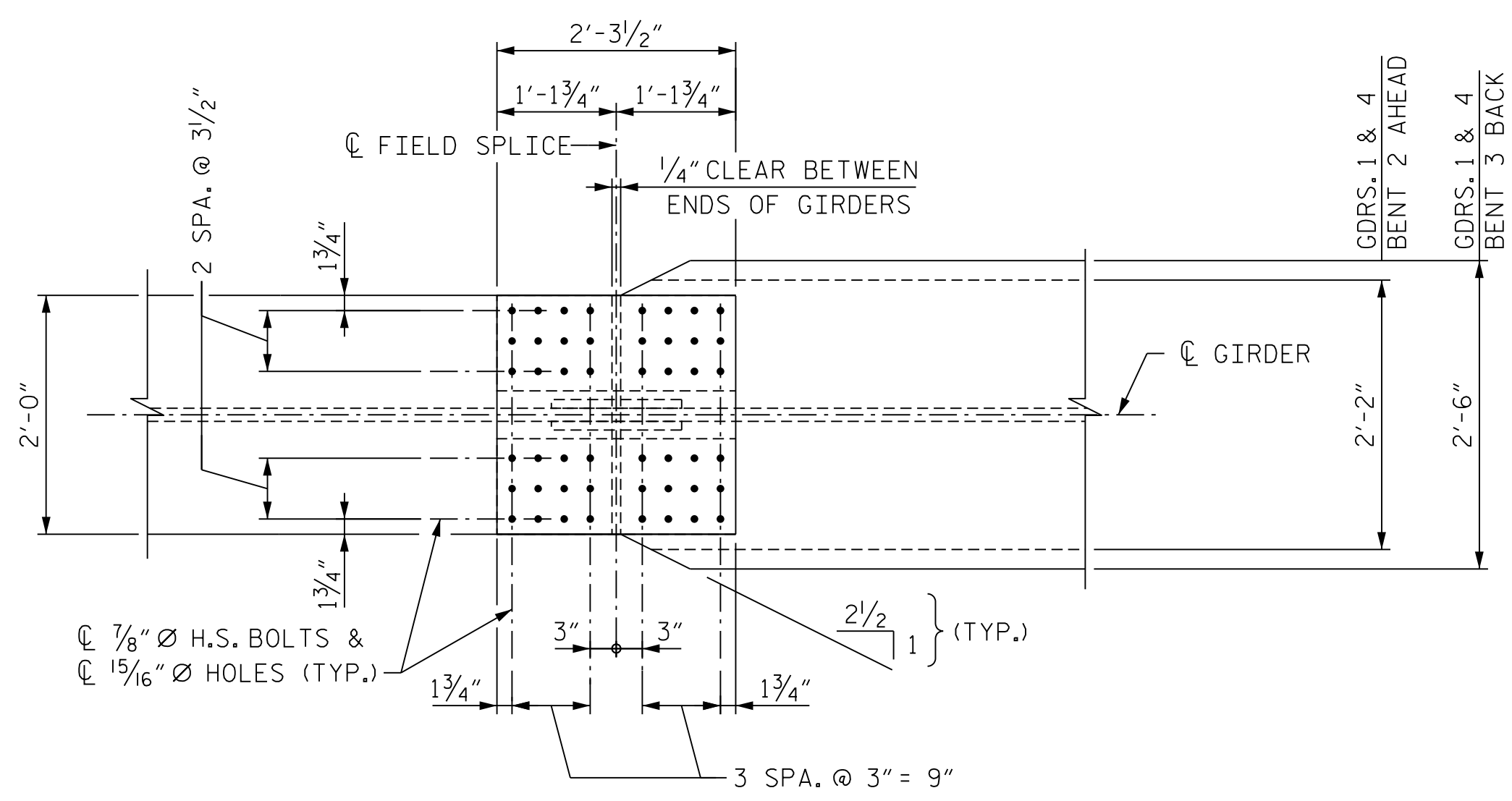

**PLAN (TOP OF TOP FLANGE)**

(STUDS NOT SHOWN FOR CLARITY)

\* = SHEAR STUDS ARE TO BE SHOP WELDED ON TOP OF PLATE BEFORE FIELD ASSEMBLY

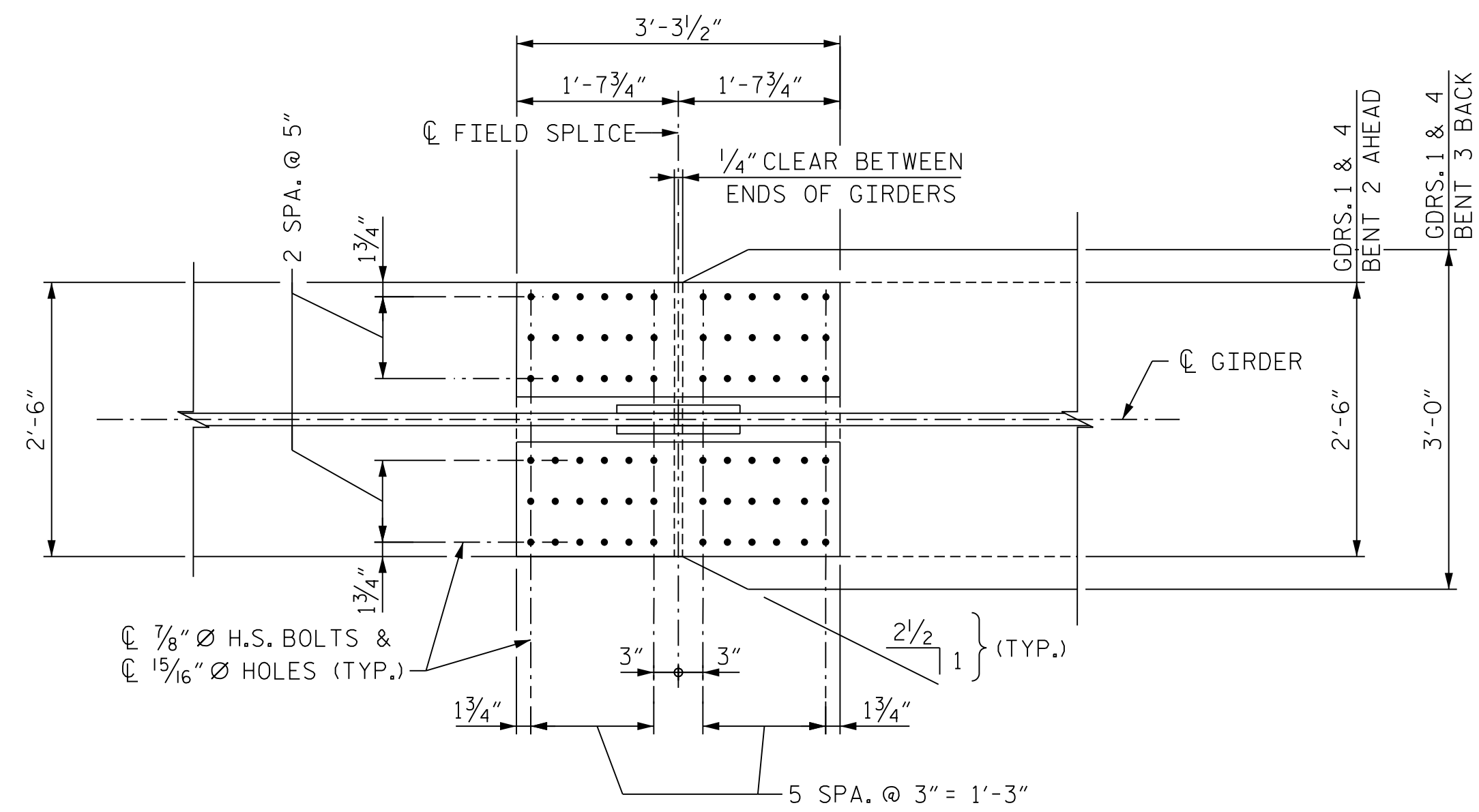

**PLAN (TOP OF BOTTOM FLANGE)**

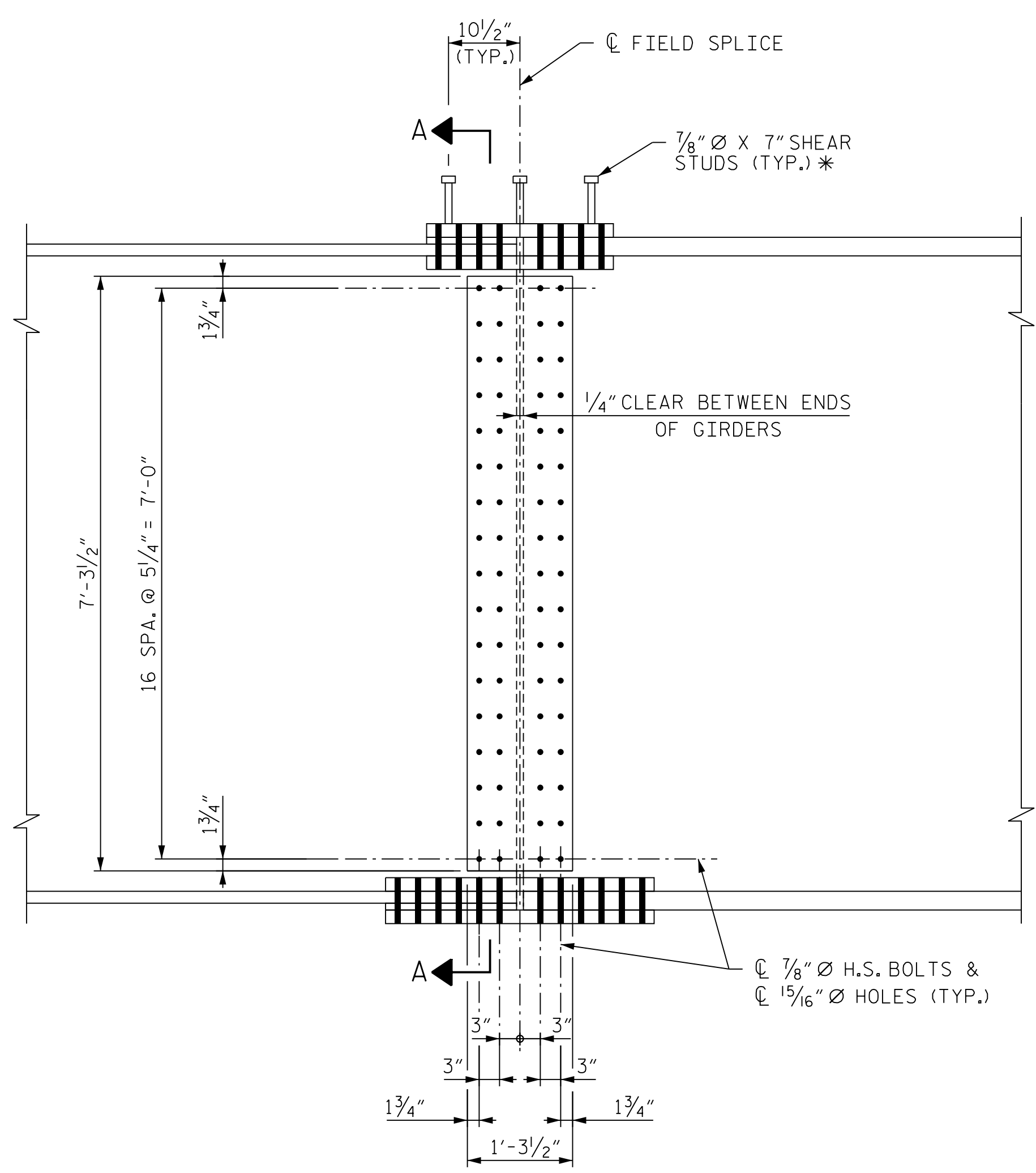

**ELEVATION**

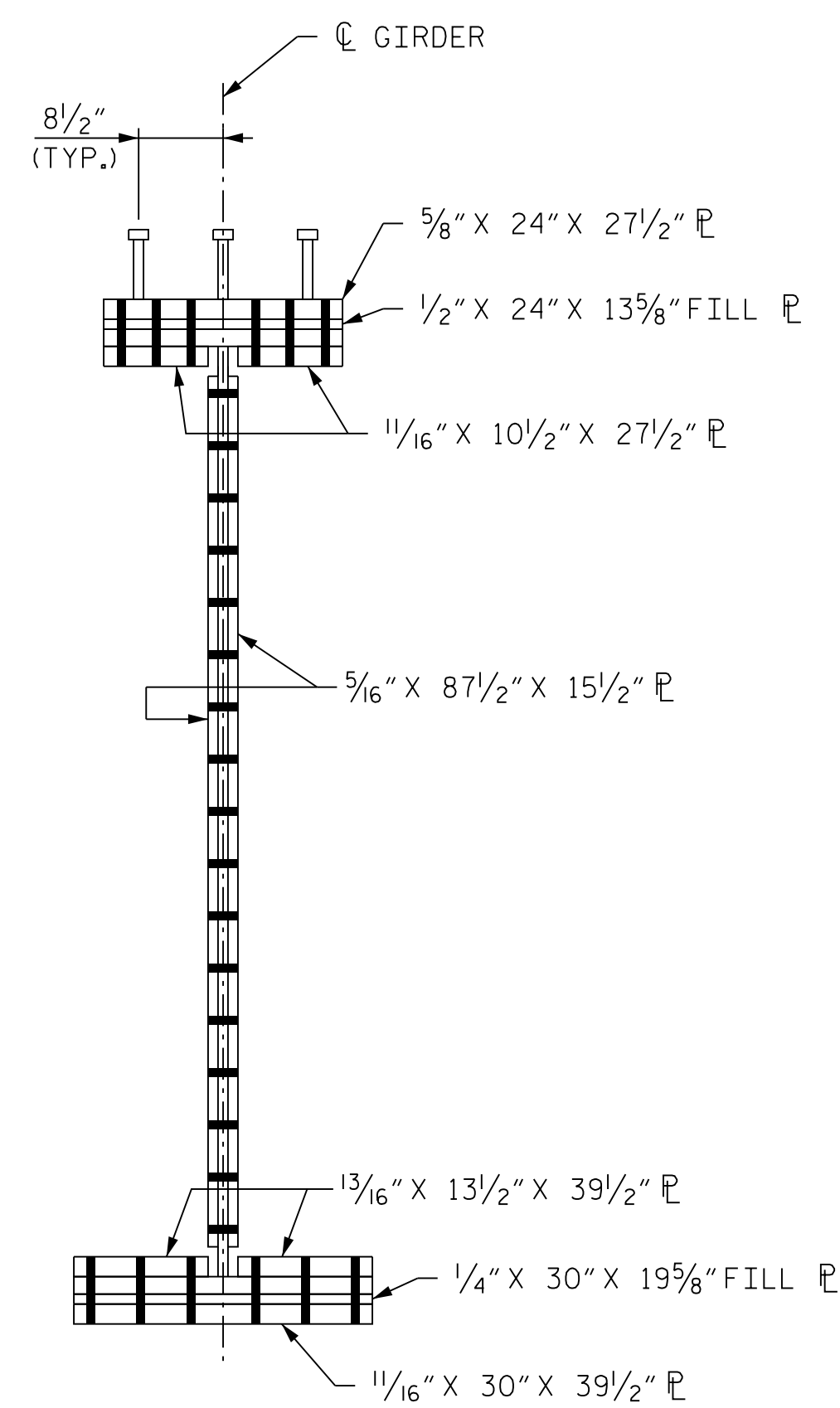

**SECTION A-A**

**NOTE**  
ORIENTATION OF PLAN AND ELEVATION VIEWS MAY VARY BASED ON FIELD SPLICE LOCATION

PROJECT NO. U-2579AB  
FORSYTH COUNTY  
 STATION: 60+66.06 -Y15FLYAC-

SHEET 3 OF 19

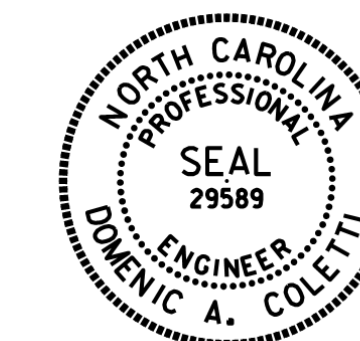

STATE OF NORTH CAROLINA  
 DEPARTMENT OF TRANSPORTATION  
 RALEIGH

**SUPERSTRUCTURE  
 BOLTED FIELD SPLICE  
 DETAILS - TYPE "C"**

REVISIONS						SHEET NO. S04-043 TOTAL SHEETS 144
NO.	BY:	DATE:	NO.	BY:	DATE:	
1	--	--	3	--	--	
2	--	--	4	--	--	

PLOT DRIVER: NCDOT... PENTABLE: NCDOT STRUCTURES DEFAULT PEN.tbl  
 USER: PPETERSO DATE: 10/14/2021 TIME: 4:01:43 PM  
 FILE: ... \SUPERS

DES BY: <u>G. SCHMITZ</u>	DATE: <u>07/19</u>	DWG BY: <u>B. PETERSON</u>	DATE: <u>07/19</u>
DES CHK: <u>D. OLDS</u>	DATE: <u>08/19</u>	CHK BY: <u>T. ANDREWS</u>	DATE: <u>10/19</u>

**HDR** HDR Engineering, Inc. of the Carolinas  
 555 Fayetteville St., Suite 900 Raleigh, N.C. 27601  
 N.C.B.E.L.S. License Number: F-0116

10/15/2021  
 DOCUMENT NOT CONSIDERED FINAL  
 UNLESS ALL SIGNATURES COMPLETED

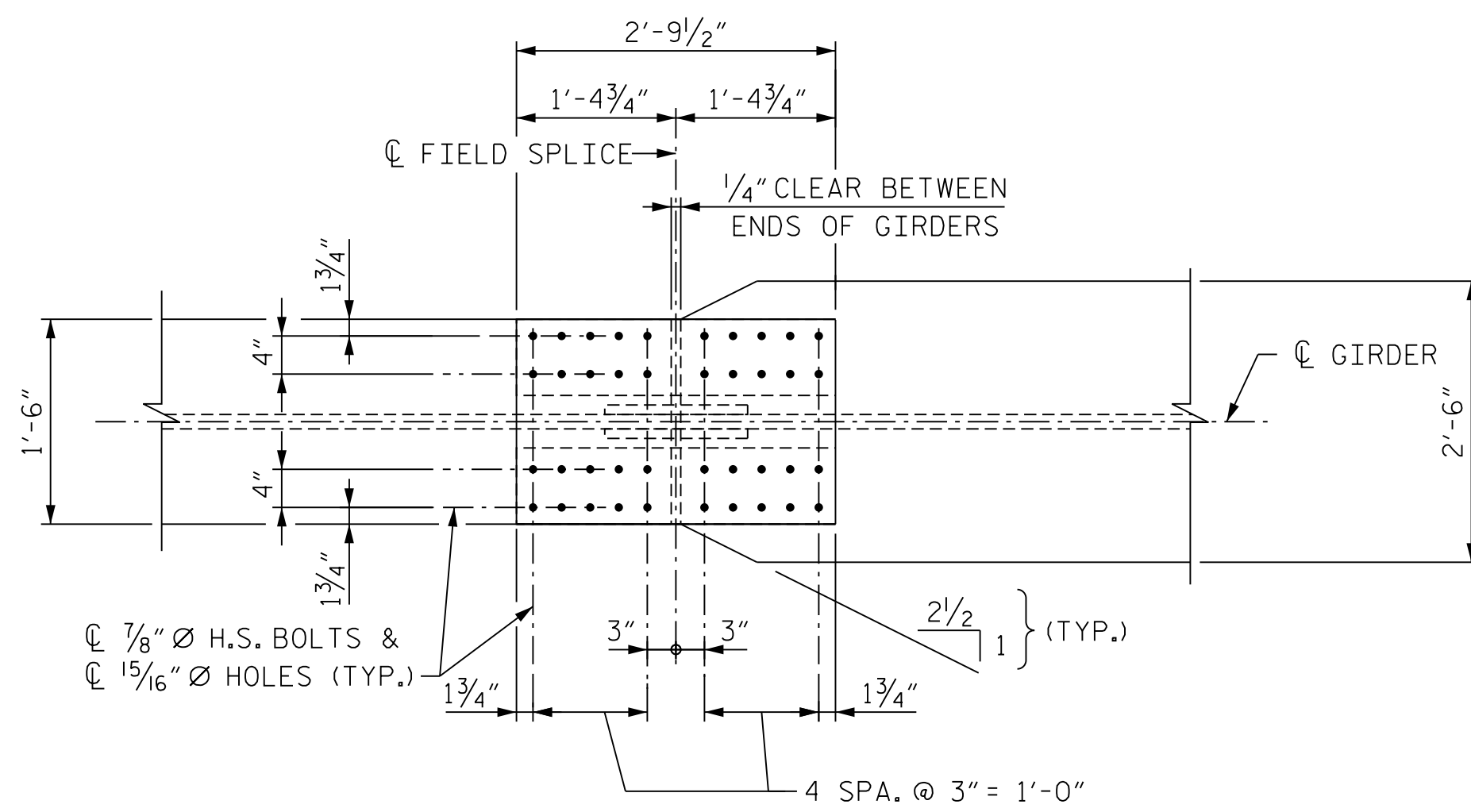

**PLAN (TOP OF TOP FLANGE)**

(STUDS NOT SHOWN FOR CLARITY)

\* = SHEAR STUDS ARE TO BE SHOP WELDED ON TOP OF PLATE BEFORE FIELD ASSEMBLY

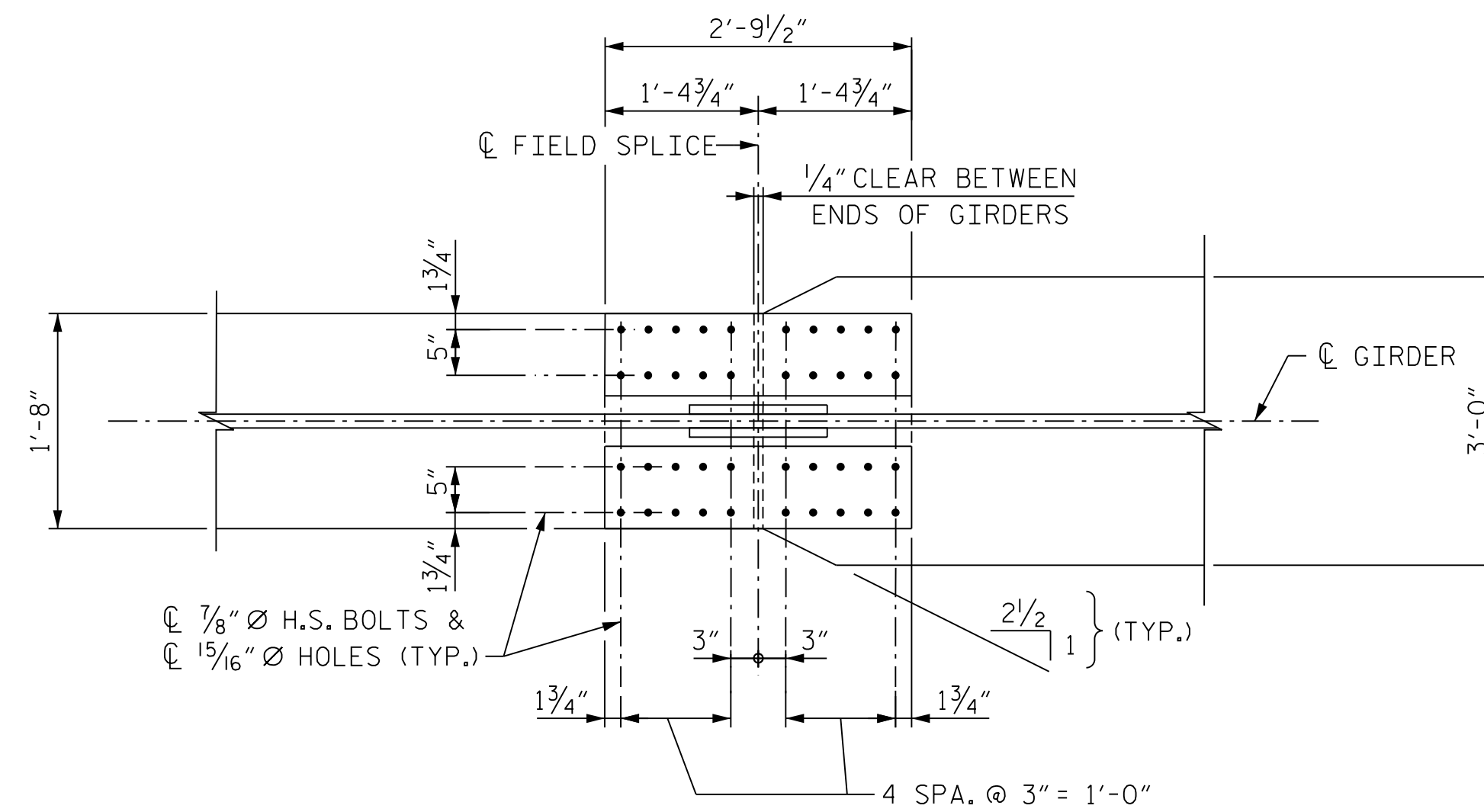

**PLAN (TOP OF BOTTOM FLANGE)**

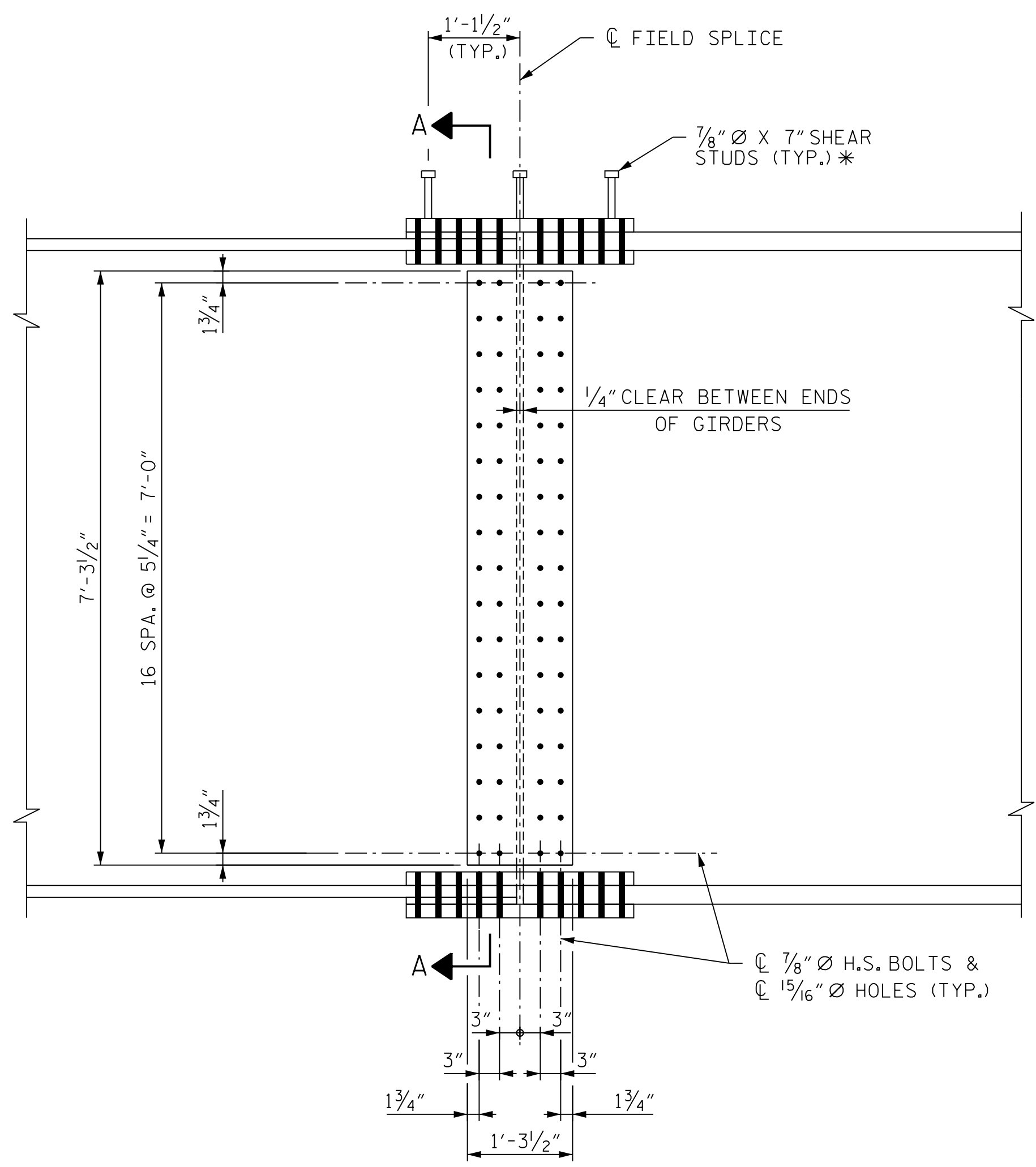

**ELEVATION**

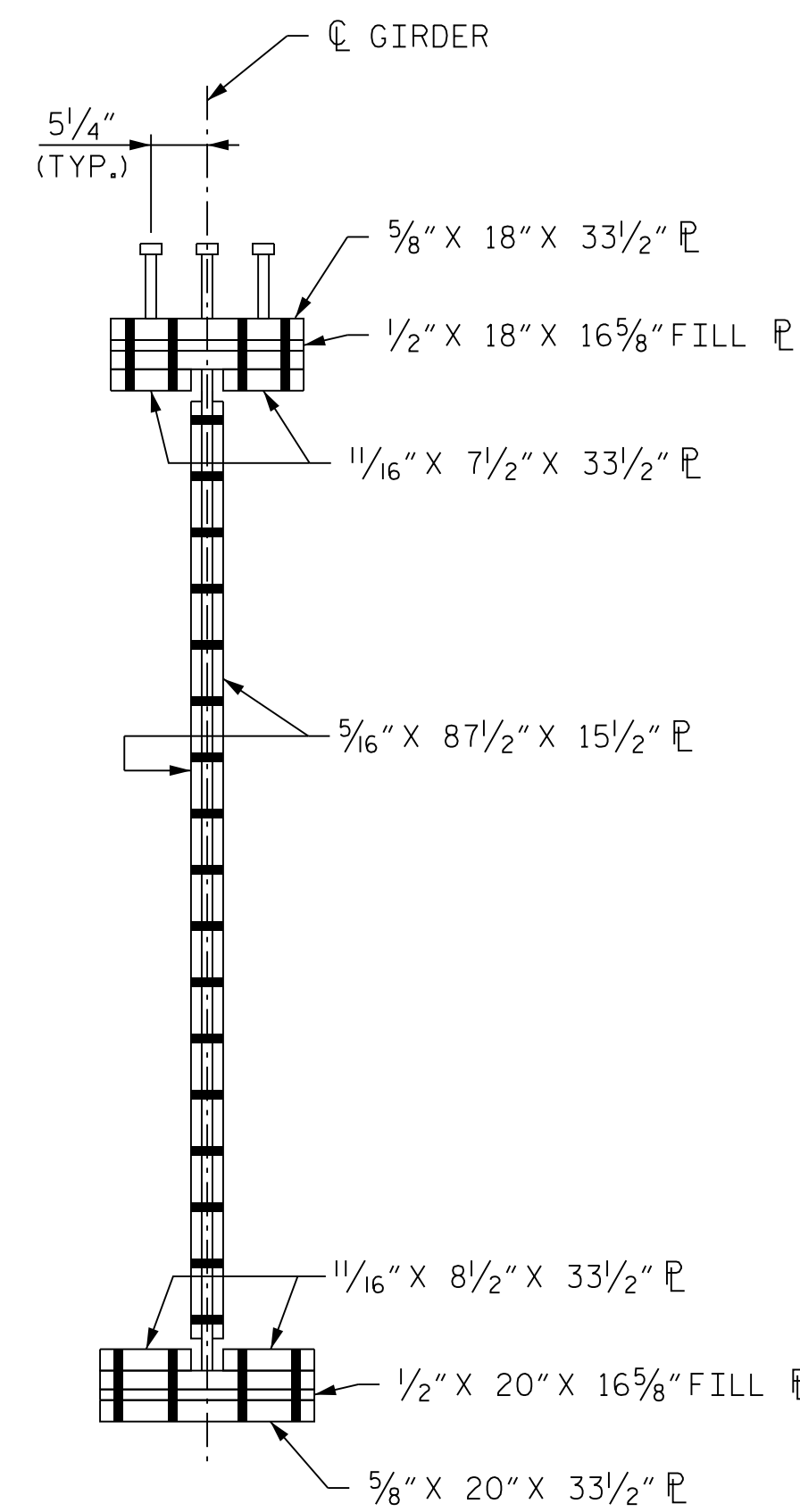

**SECTION A-A**

**NOTE**  
ORIENTATION OF PLAN AND ELEVATION VIEWS MAY VARY BASED ON FIELD SPLICE LOCATION

PROJECT NO. U-2579AB  
FORSYTH COUNTY  
STATION: 60+66.06 -Y15FLYAC-

SHEET 4 OF 19



10/15/2021

STATE OF NORTH CAROLINA  
DEPARTMENT OF TRANSPORTATION  
RALEIGH  
**SUPERSTRUCTURE  
BOLTED FIELD SPLICE  
DETAILS - TYPE "D"**

REVISIONS						SHEET NO. S04-044 TOTAL SHEETS 144
NO.	BY:	DATE:	NO.	BY:	DATE:	
1	--	--	3	--	--	
2	--	--	4	--	--	



DOCUMENT NOT CONSIDERED FINAL UNLESS ALL SIGNATURES COMPLETED

PLOT DRIVER: NCDOT\_pdf\_color\_eng-50.ppt  
 USER: PPETERSO DATE: 10/14/2021  
 FILE: ... \SUPERS

DES BY: <u>G. SCHMITZ</u>	DATE: <u>07/19</u>	DWG BY: <u>B. PETERSON</u>	DATE: <u>07/19</u>
DES CHK: <u>D. OLDS</u>	DATE: <u>08/19</u>	CHK BY: <u>T. ANDREWS</u>	DATE: <u>10/19</u>



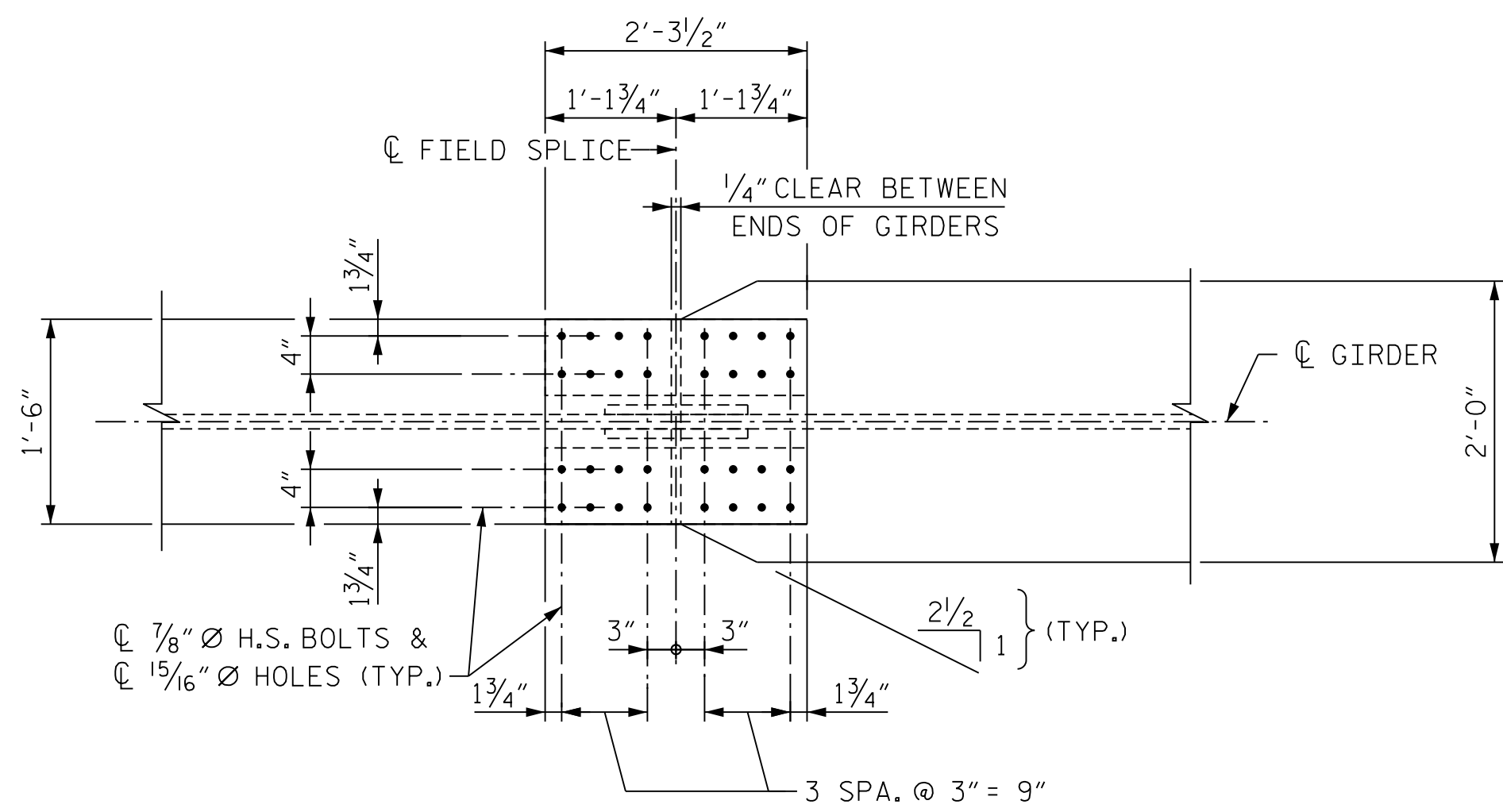

**PLAN (TOP OF TOP FLANGE)**

(STUDS NOT SHOWN FOR CLARITY)

\* = SHEAR STUDS ARE TO BE SHOP WELDED ON TOP OF PLATE BEFORE FIELD ASSEMBLY

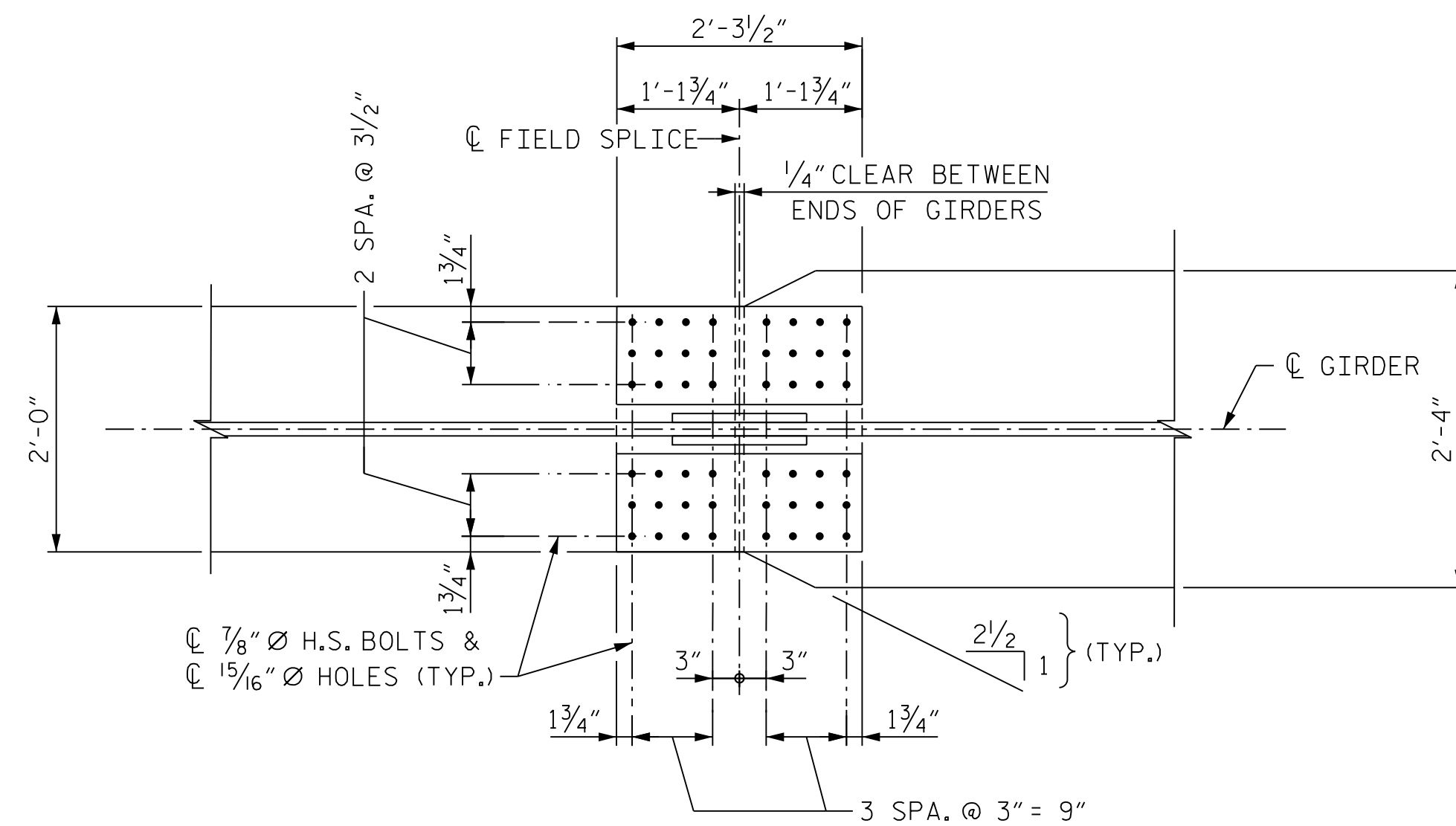

**PLAN (TOP OF BOTTOM FLANGE)**

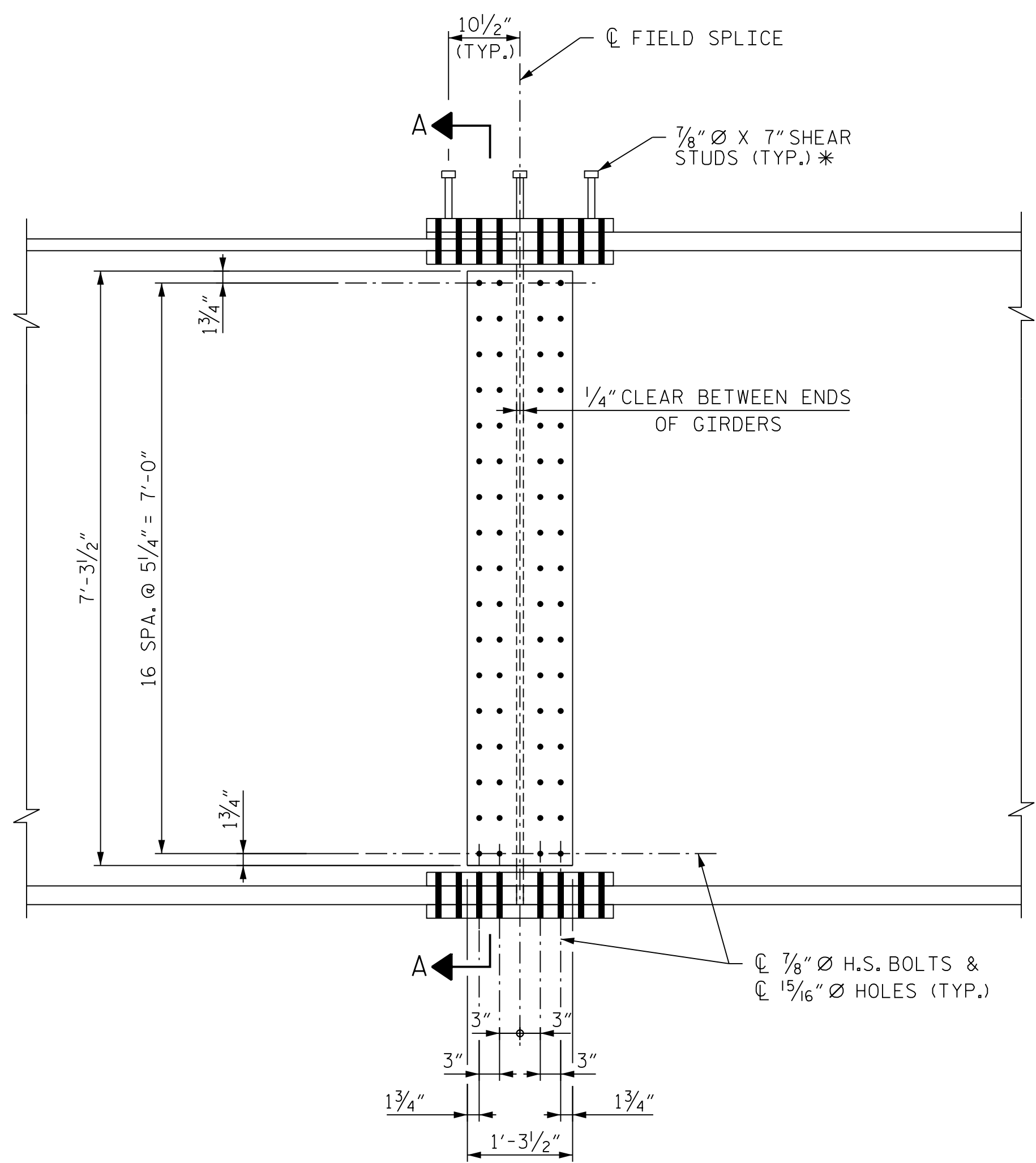

**ELEVATION**

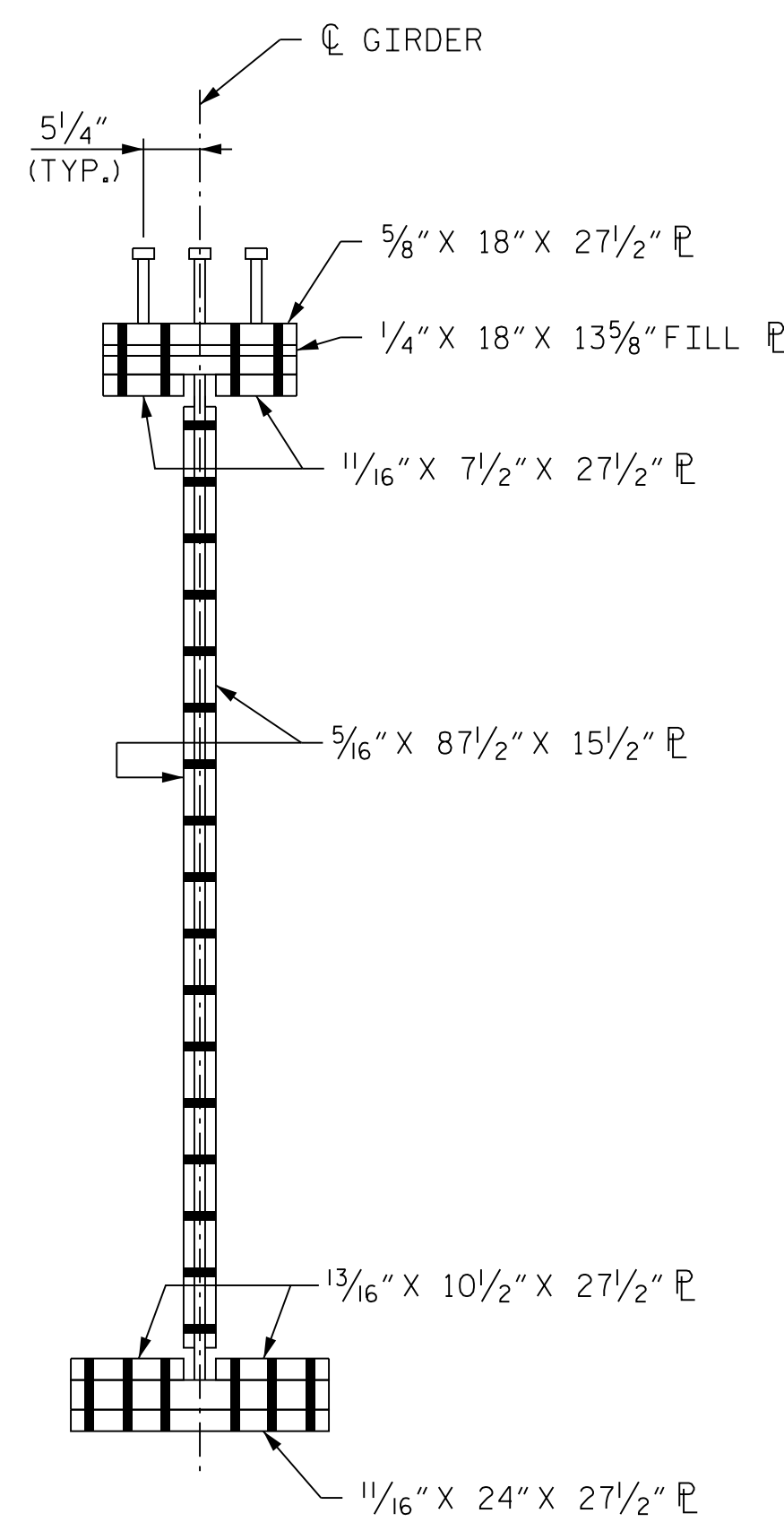

**SECTION A-A**

**NOTE**

ORIENTATION OF PLAN AND ELEVATION VIEWS MAY VARY BASED ON FIELD SPLICE LOCATION

PROJECT NO. U-2579AB  
FORSYTH COUNTY  
 STATION: 60+66.06 -Y15FLYAC-

SHEET 5 OF 19

STATE OF NORTH CAROLINA  
 DEPARTMENT OF TRANSPORTATION  
 RALEIGH

**SUPERSTRUCTURE  
 BOLTED FIELD SPLICE  
 DETAILS - TYPE "E"**



*Dominic A. Colletti* 10/15/2021

**REVISIONS**

NO.	BY:	DATE:	NO.	BY:	DATE:
1	--	--	3	--	--
2	--	--	4	--	--

SHEET NO. S04-045  
 TOTAL SHEETS 144



**DOCUMENT NOT CONSIDERED FINAL  
 UNLESS ALL SIGNATURES COMPLETED**

PLOT DRIVER: NCDOT... PENTABLE: NCDOT... USER: PPETERSO... DATE: 10/14/2021... FILE: ... \ASUPERS

DES BY: <u>G. SCHMITZ</u>	DATE: <u>07/19</u>	DWG BY: <u>B. PETERSON</u>	DATE: <u>07/19</u>
DES CHK: <u>D. OLDS</u>	DATE: <u>08/19</u>	CHK BY: <u>T. ANDREWS</u>	DATE: <u>10/19</u>

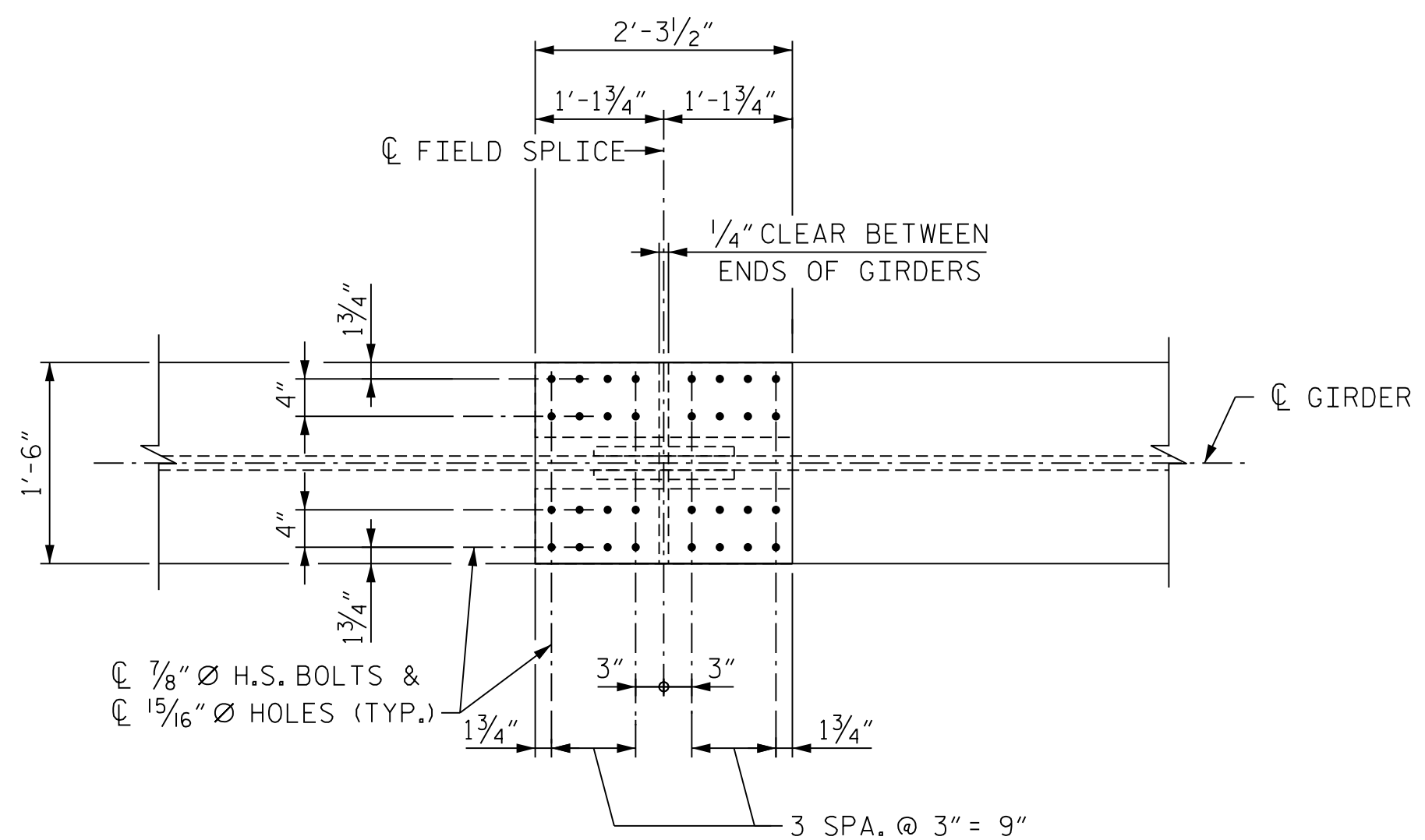

**PLAN (TOP OF TOP FLANGE)**  
(STUDS NOT SHOWN FOR CLARITY)

\* = SHEAR STUDS ARE TO BE SHOP WELDED ON TOP OF PLATE BEFORE FIELD ASSEMBLY

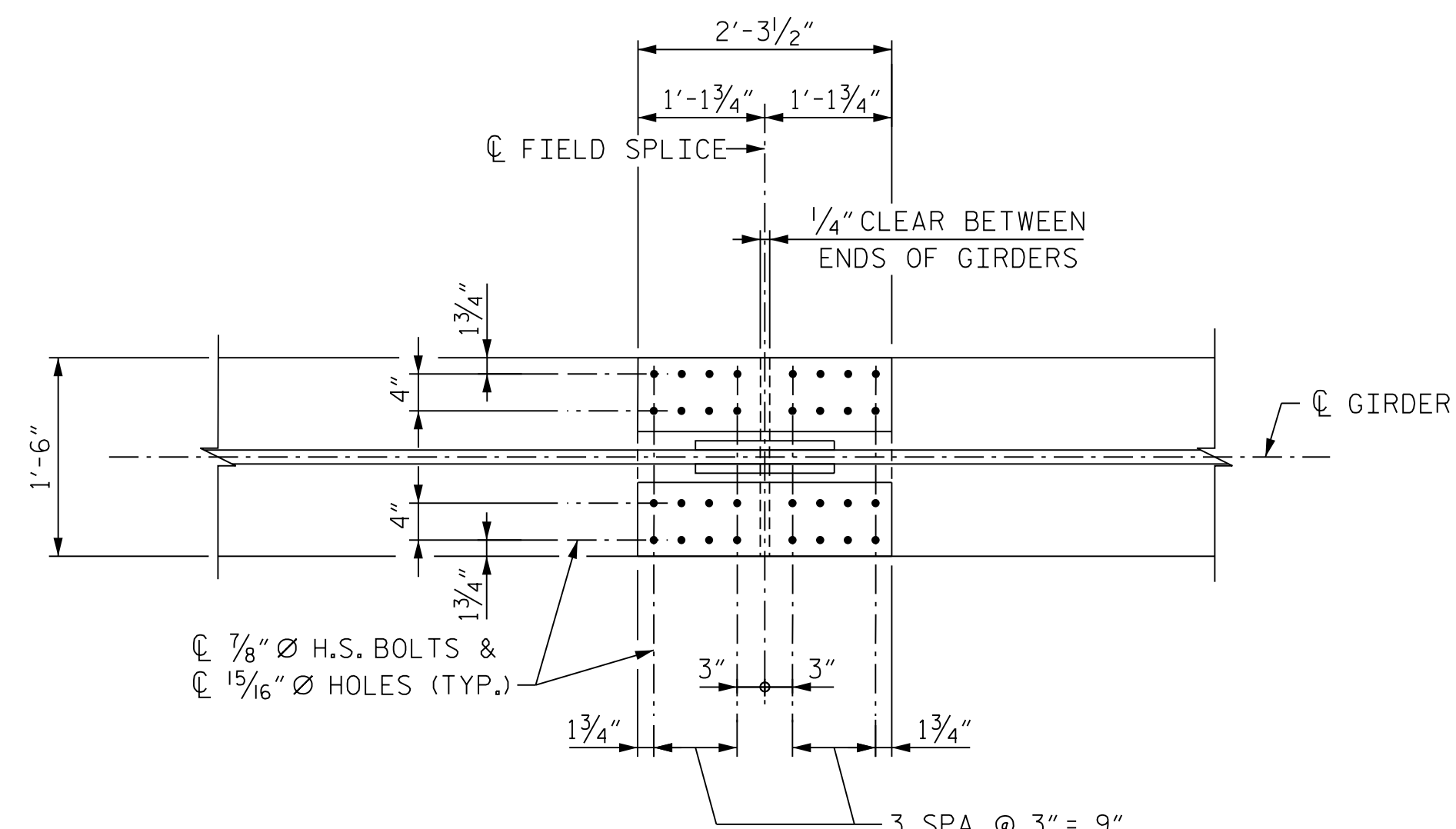

**PLAN (TOP OF BOTTOM FLANGE)**

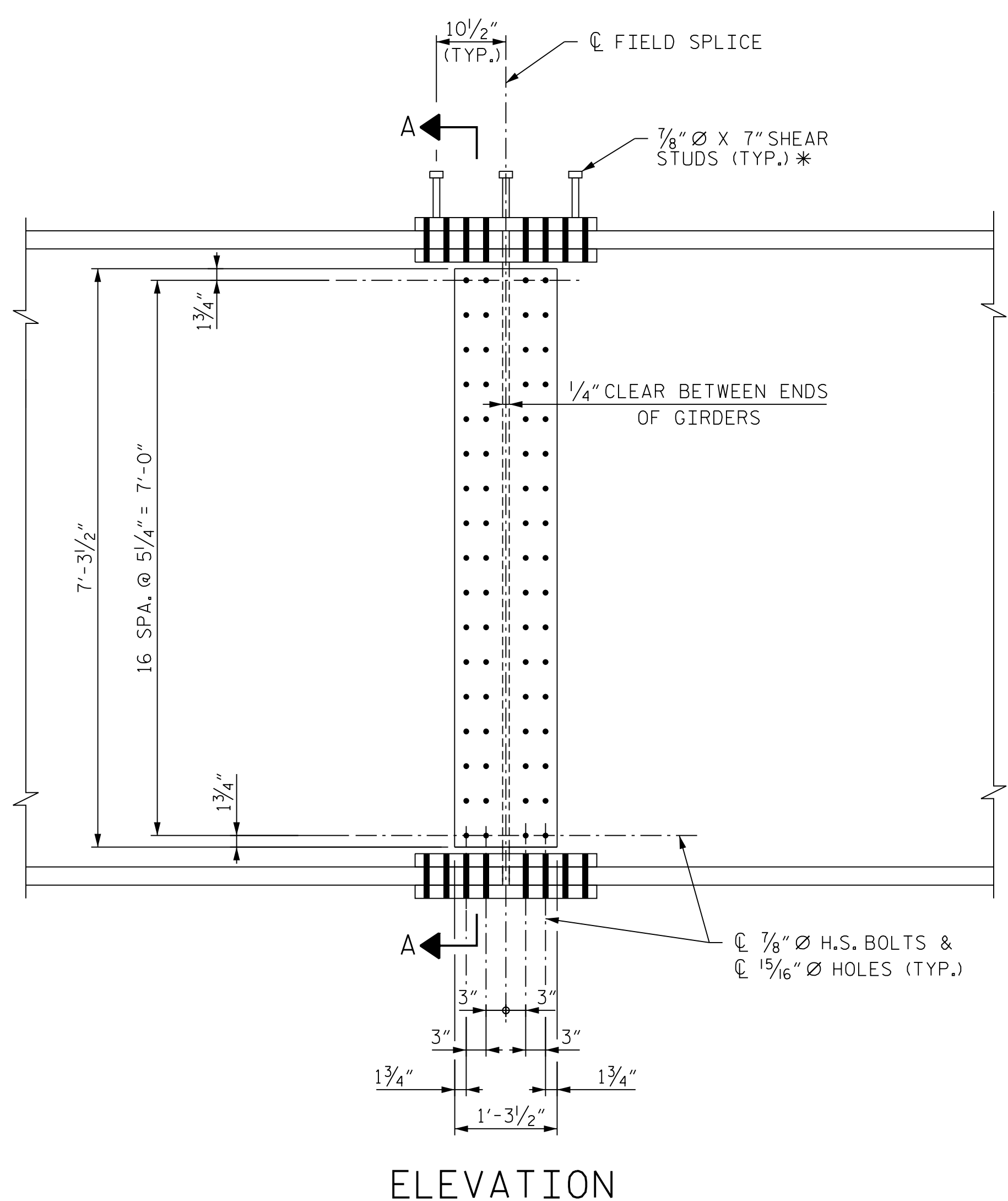

**ELEVATION**

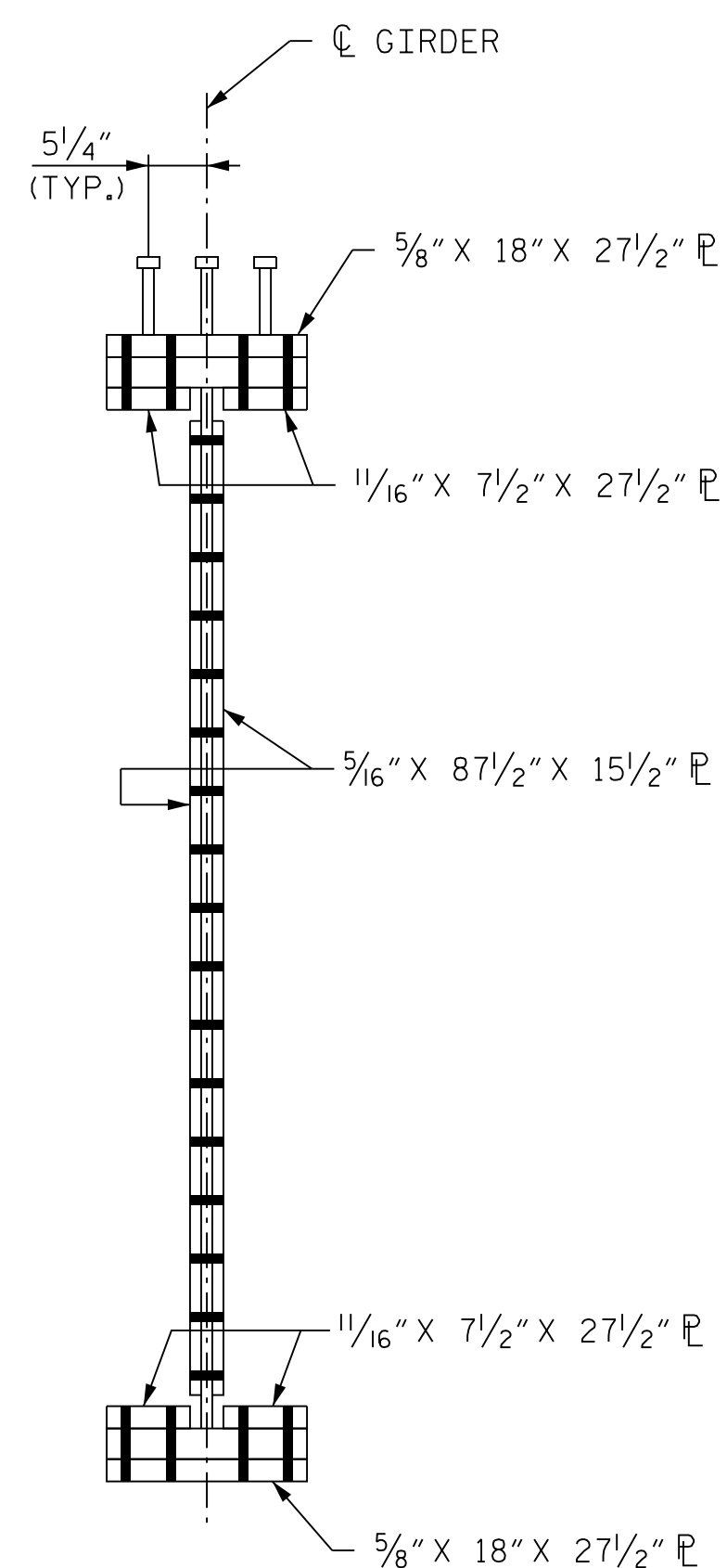

**SECTION A-A**

**NOTE**  
ORIENTATION OF PLAN AND ELEVATION VIEWS MAY VARY BASED ON FIELD SPLICE LOCATION

PROJECT NO. U-2579AB  
FORSYTH COUNTY  
STATION: 60+66.06 -Y15FLYAC-

SHEET 6 OF 19

STATE OF NORTH CAROLINA  
DEPARTMENT OF TRANSPORTATION  
RALEIGH

**SUPERSTRUCTURE  
BOLTED FIELD SPLICE  
DETAILS - TYPE "F"**



10/15/2021

REVISIONS						SHEET NO. SD4-046 TOTAL SHEETS 144
NO.	BY:	DATE:	NO.	BY:	DATE:	
1	--	--	3	--	--	
2	--	--	4	--	--	

**HDR** HDR Engineering, Inc. of the Carolinas  
555 Fayetteville St., Suite 900 Raleigh, N.C. 27601  
N.C.B.E.L.S. License Number: F-0116

DOCUMENT NOT CONSIDERED FINAL  
UNLESS ALL SIGNATURES COMPLETED

PLOT DRIVER: NCDOT\_pdf\_color\_eng-50.ppt  
USER: PPETERSO DATE: 10/14/2021  
PENTABLE: NCDOT\_STRUCTURES\_DEFAULT\_PEN.tbl  
TIME: 4:01:46 PM  
FILE: ... \SUPERS

DES BY: <u>G. SCHMITZ</u>	DATE: <u>07/19</u>	DWG BY: <u>B. PETERSON</u>	DATE: <u>07/19</u>
DES CHK: <u>D. OLDS</u>	DATE: <u>08/19</u>	CHK BY: <u>T. ANDREWS</u>	DATE: <u>10/19</u>

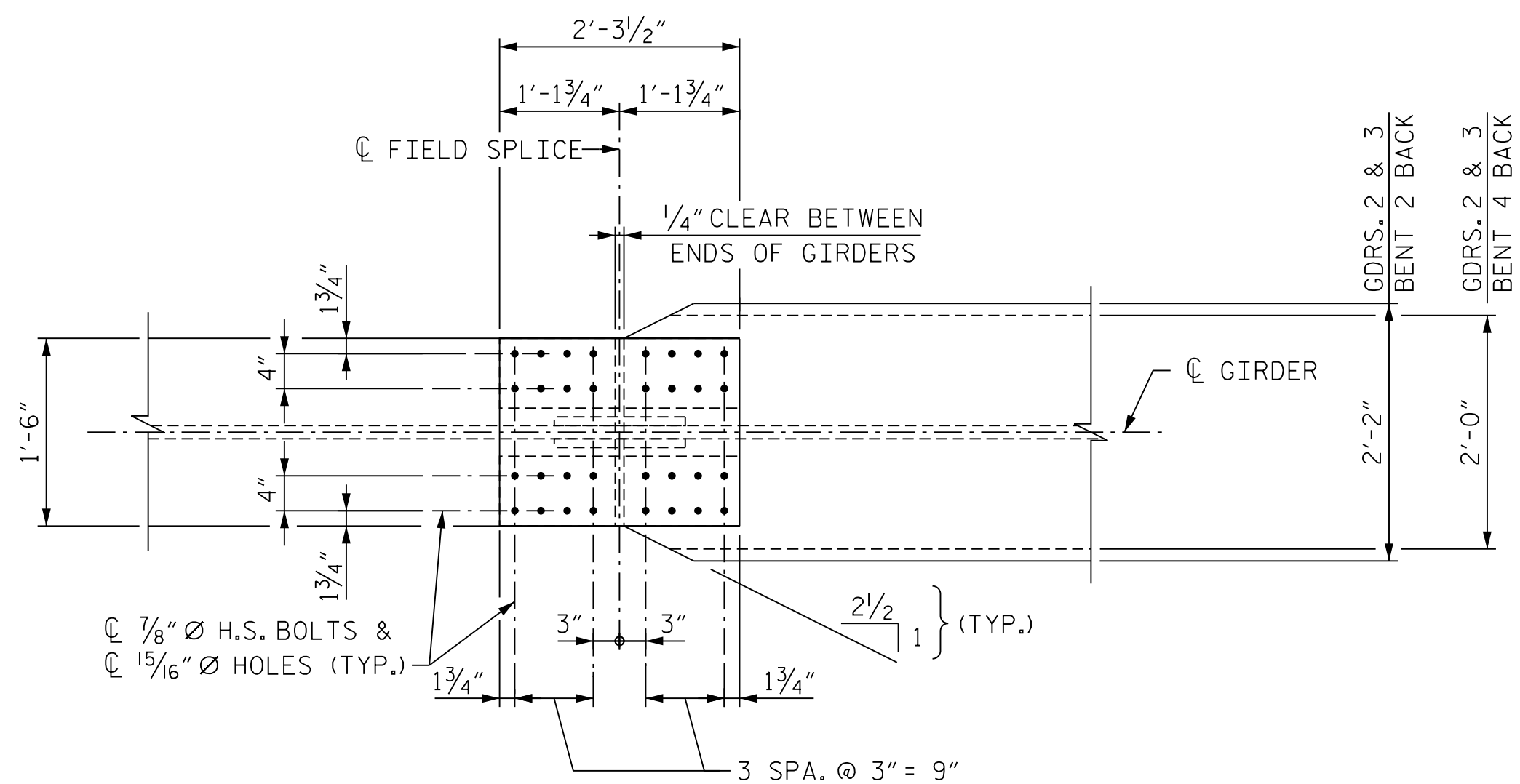

PLAN (TOP OF TOP FLANGE)

(STUDS NOT SHOWN FOR CLARITY)

\* = SHEAR STUDS ARE TO BE SHOP WELDED ON TOP OF PLATE BEFORE FIELD ASSEMBLY

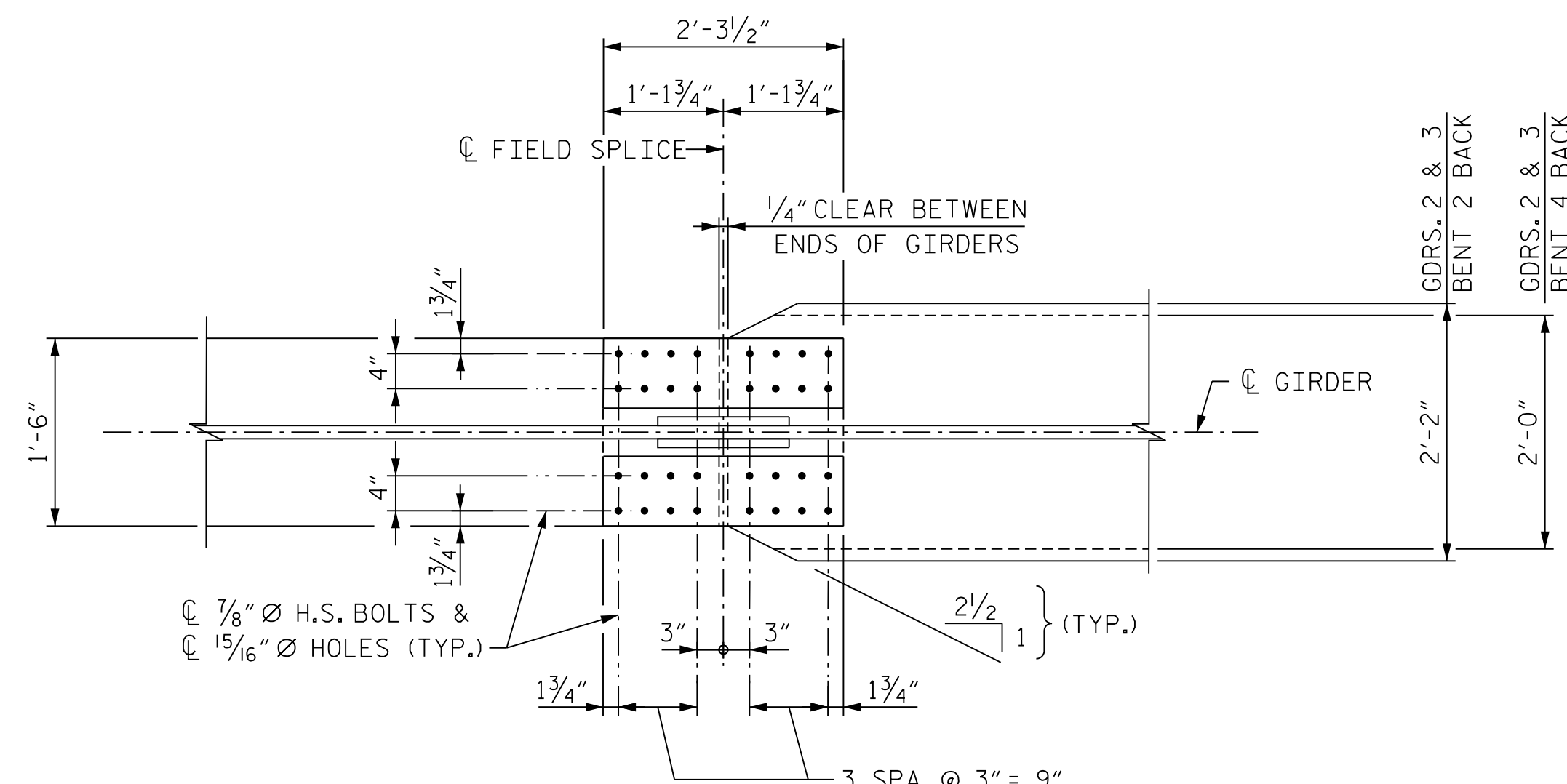

PLAN (TOP OF BOTTOM FLANGE)

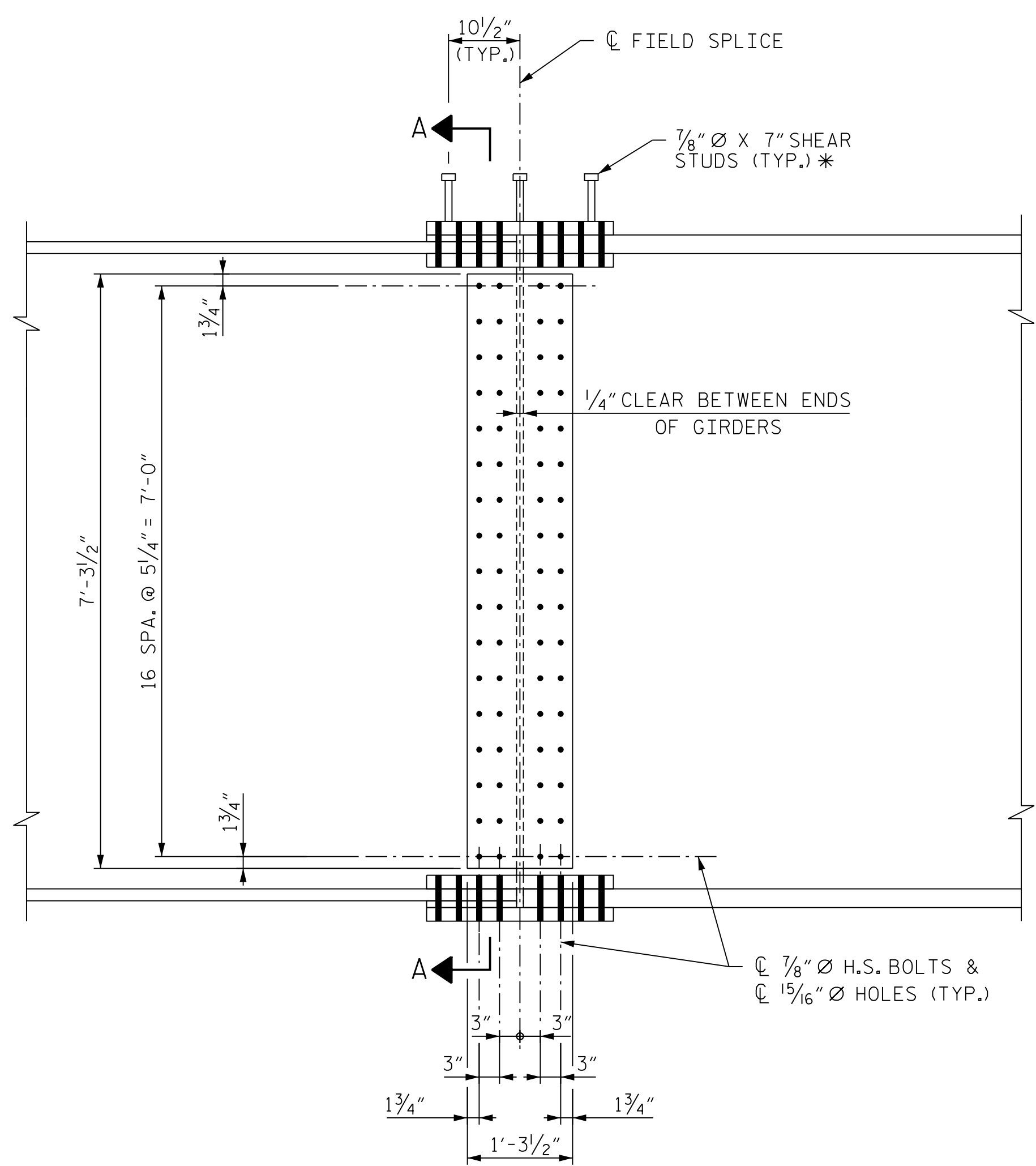

ELEVATION

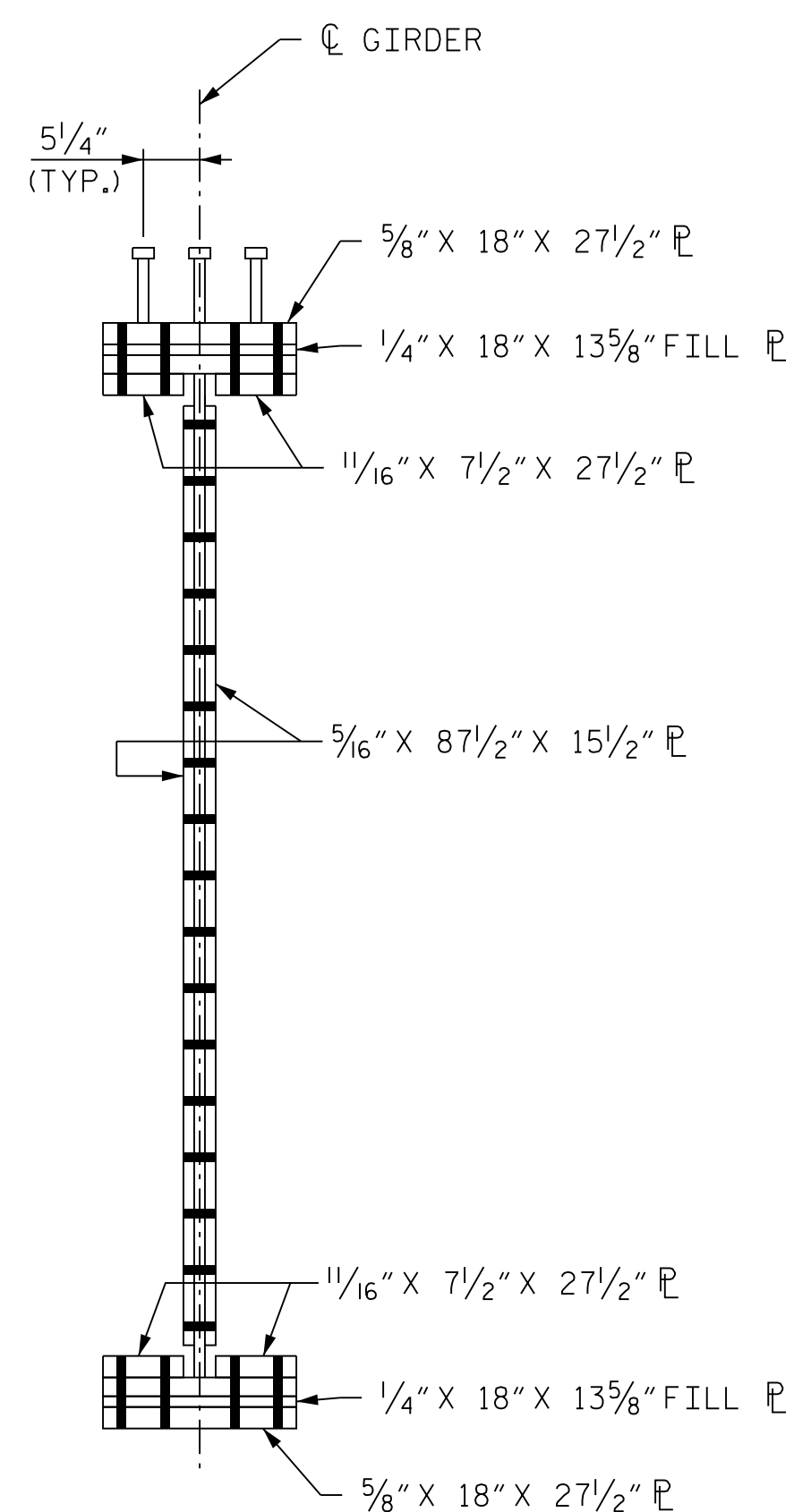

SECTION A-A

NOTE  
ORIENTATION OF PLAN AND ELEVATION VIEWS  
MAY VARY BASED ON FIELD SPLICE LOCATION

PROJECT NO. U-2579AB  
FORSYTH COUNTY  
STATION: 60+66.06 -Y15FLYAC-

SHEET 7 OF 19

STATE OF NORTH CAROLINA  
DEPARTMENT OF TRANSPORTATION  
RALEIGH

SUPERSTRUCTURE  
BOLTED FIELD SPLICE  
DETAILS - TYPE "G"

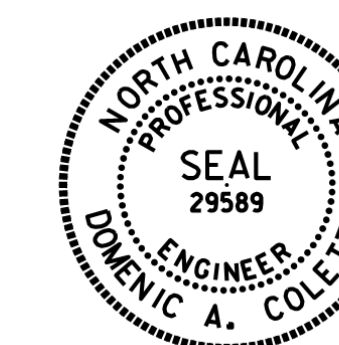

10/15/2021

REVISIONS

NO.	BY:	DATE:	NO.	BY:	DATE:
1	--	--	3	--	--
2	--	--	4	--	--

SHEET NO. S04-047  
TOTAL SHEETS 144

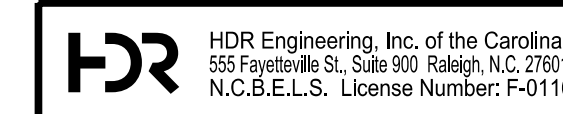

DOCUMENT NOT CONSIDERED FINAL  
UNLESS ALL SIGNATURES COMPLETED

PLOT DRIVER: NCDOT... PENTABLE: NCDOT... USER: PPETERSO... DATE: 10/14/2021... FILE: ... \ASUPERS

DES BY: G. SCHMITZ	DATE: 07/19	DWG BY: B. PETERSON	DATE: 07/19
DES CHK: D. OLDS	DATE: 08/19	CHK BY: T. ANDREWS	DATE: 10/19

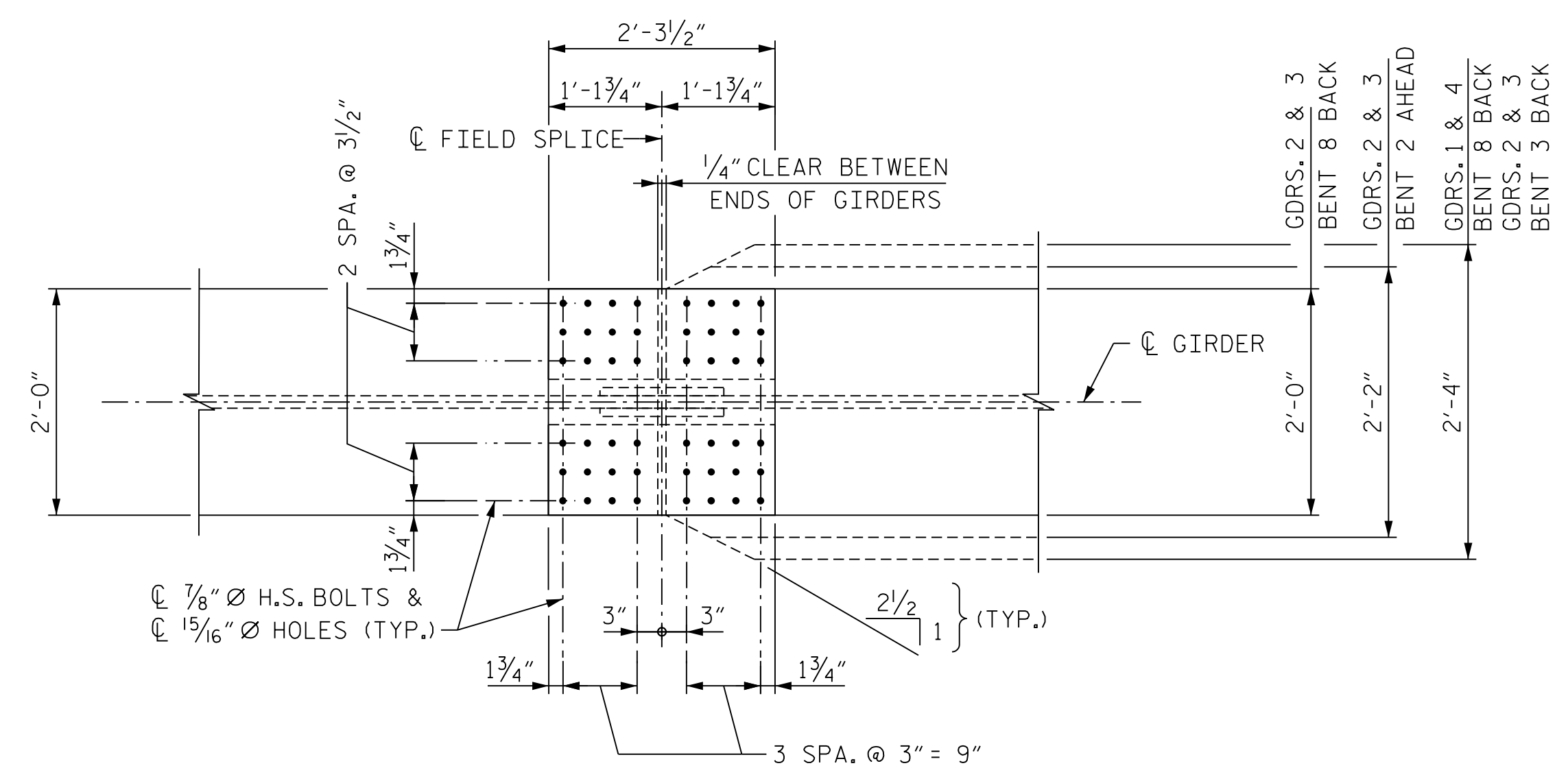

**PLAN (TOP OF TOP FLANGE)**  
(STUDS NOT SHOWN FOR CLARITY)

\* = SHEAR STUDS ARE TO BE SHOP WELDED ON TOP OF PLATE BEFORE FIELD ASSEMBLY

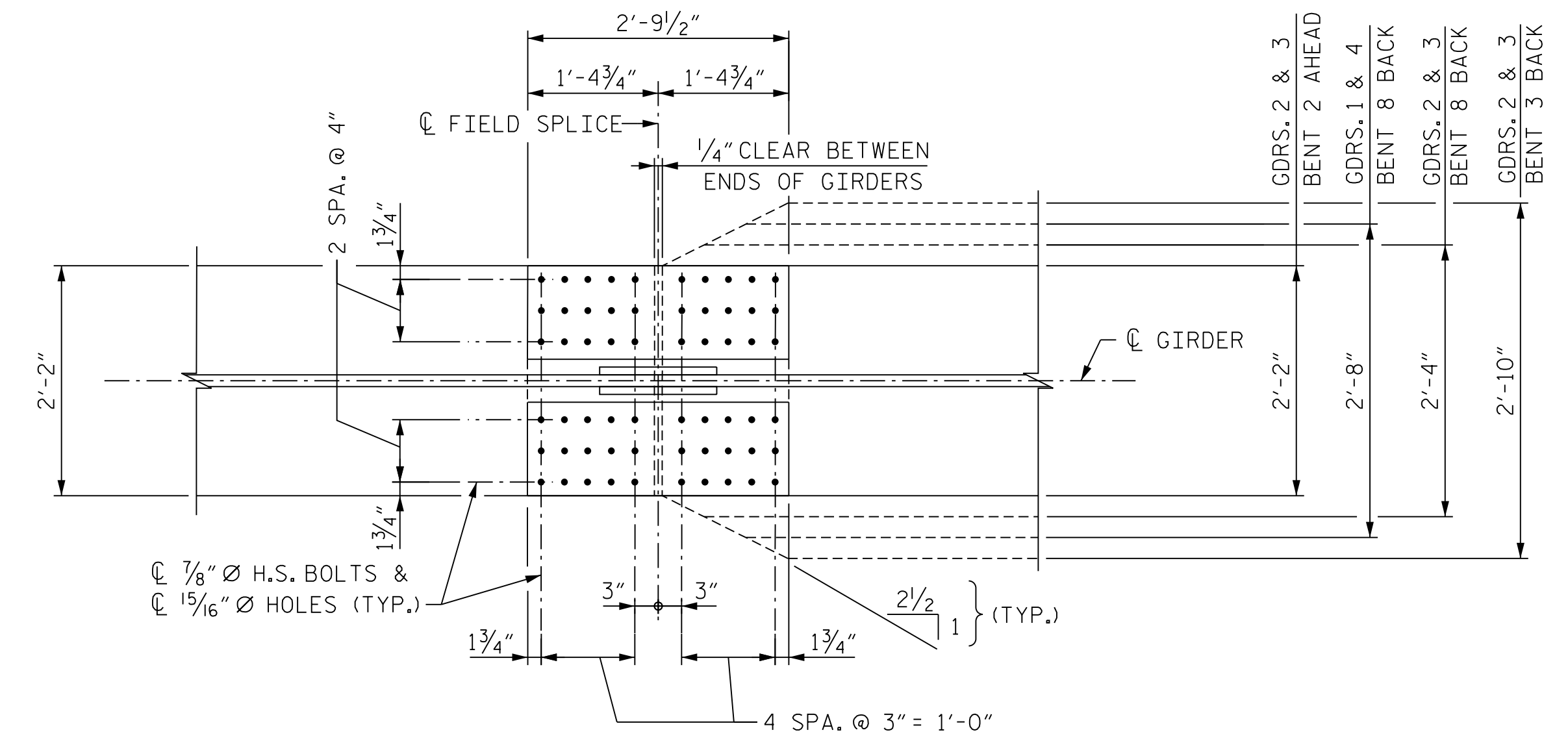

**PLAN (TOP OF BOTTOM FLANGE)**

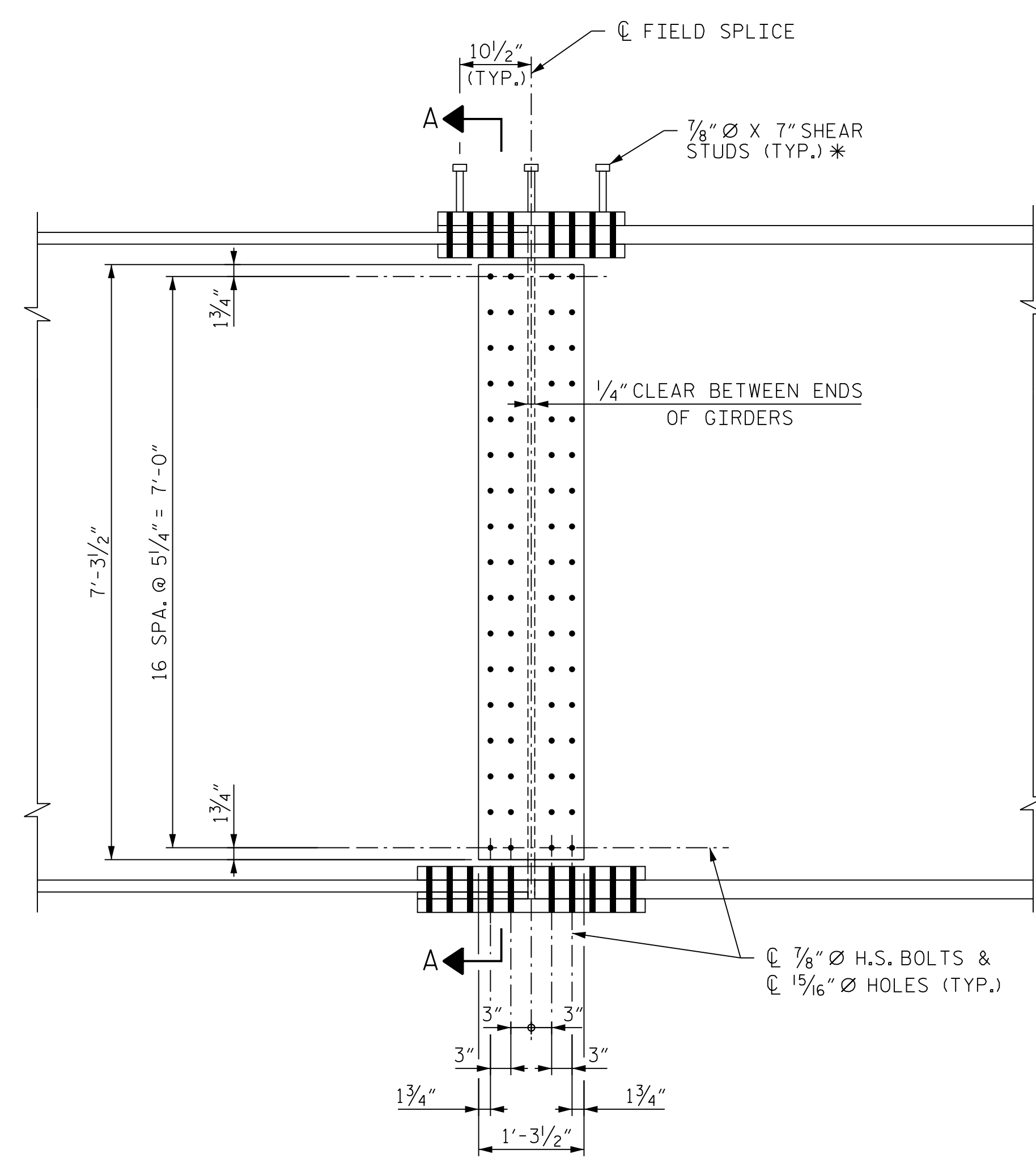

**ELEVATION**

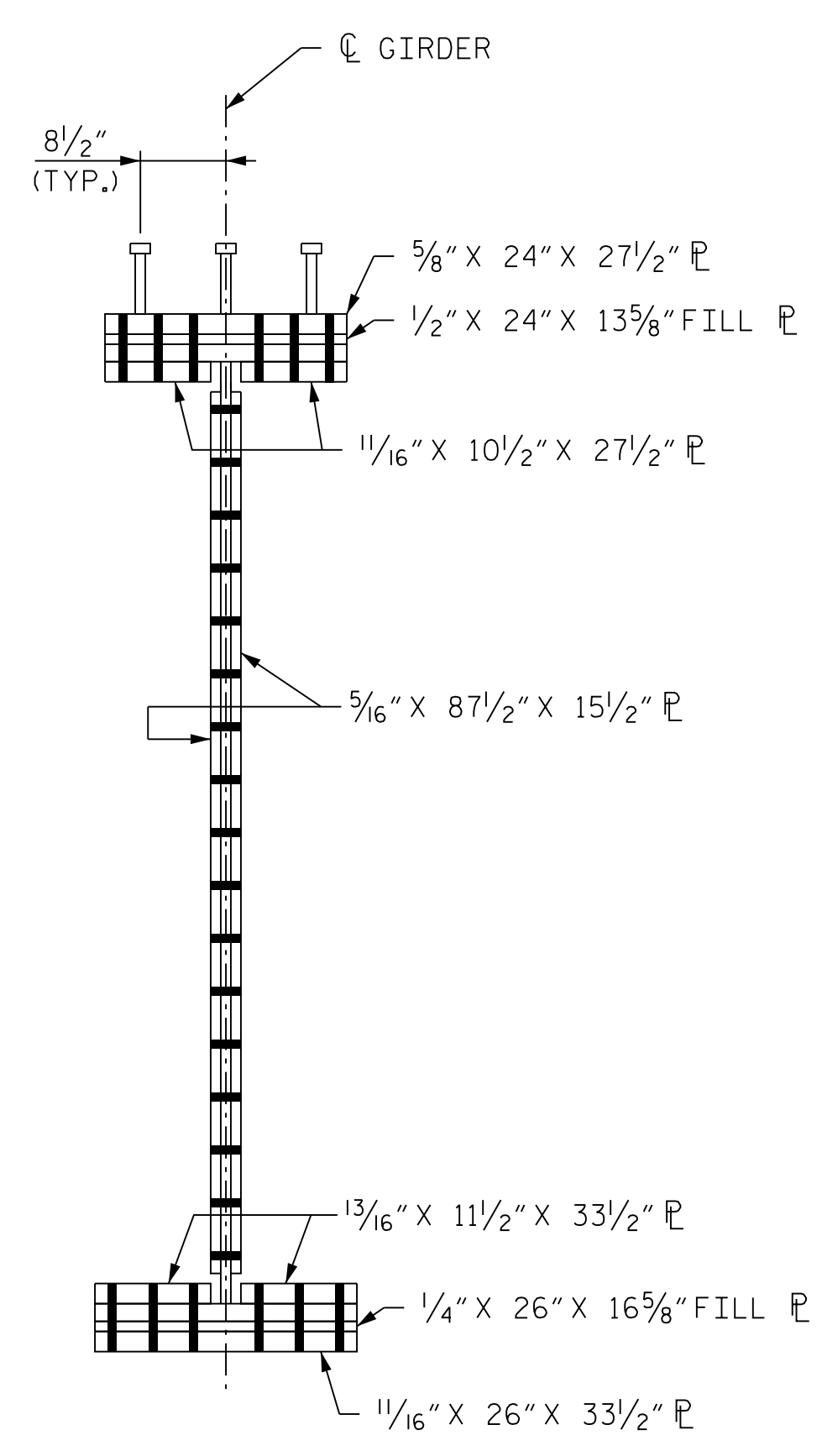

**SECTION A-A**

**NOTE**  
ORIENTATION OF PLAN AND ELEVATION VIEWS MAY VARY BASED ON FIELD SPLICE LOCATION

PROJECT NO. U-2579AB  
FORSYTH COUNTY  
STATION: 60+66.06 -Y15FLYAC-

SHEET 8 OF 19

STATE OF NORTH CAROLINA  
DEPARTMENT OF TRANSPORTATION  
RALEIGH

**SUPERSTRUCTURE  
BOLTED FIELD SPLICE  
DETAILS - TYPE "H"**



10/15/2021

DES BY: G. SCHMITZ	DATE: 07/19	DWG BY: B. PETERSON	DATE: 07/19
DES CHK: D. OLDS	DATE: 08/19	CHK BY: T. ANDREWS	DATE: 10/19

**HDR** HDR Engineering, Inc. of the Carolinas  
555 Fayetteville St., Suite 900 Raleigh, N.C. 27601  
N.C.B.E.L.S. License Number: F-0116

**DOCUMENT NOT CONSIDERED FINAL  
UNLESS ALL SIGNATURES COMPLETED**

REVISIONS						SHEET NO. S04-048 TOTAL SHEETS 144
NO.	BY:	DATE:	NO.	BY:	DATE:	
1	--	--	3	--	--	
2	--	--	4	--	--	

PLOT DRIVER: NCDOT\_pdf\_color\_eng-50.ppt  
 USER: PPETERSO DATE: 10/14/2021  
 PENTABLE: NCDOT\_STRUCTURES\_DEFAULT\_PEN.tbl  
 TIME: 4:01:49 PM  
 FILE: ... \SUPERS

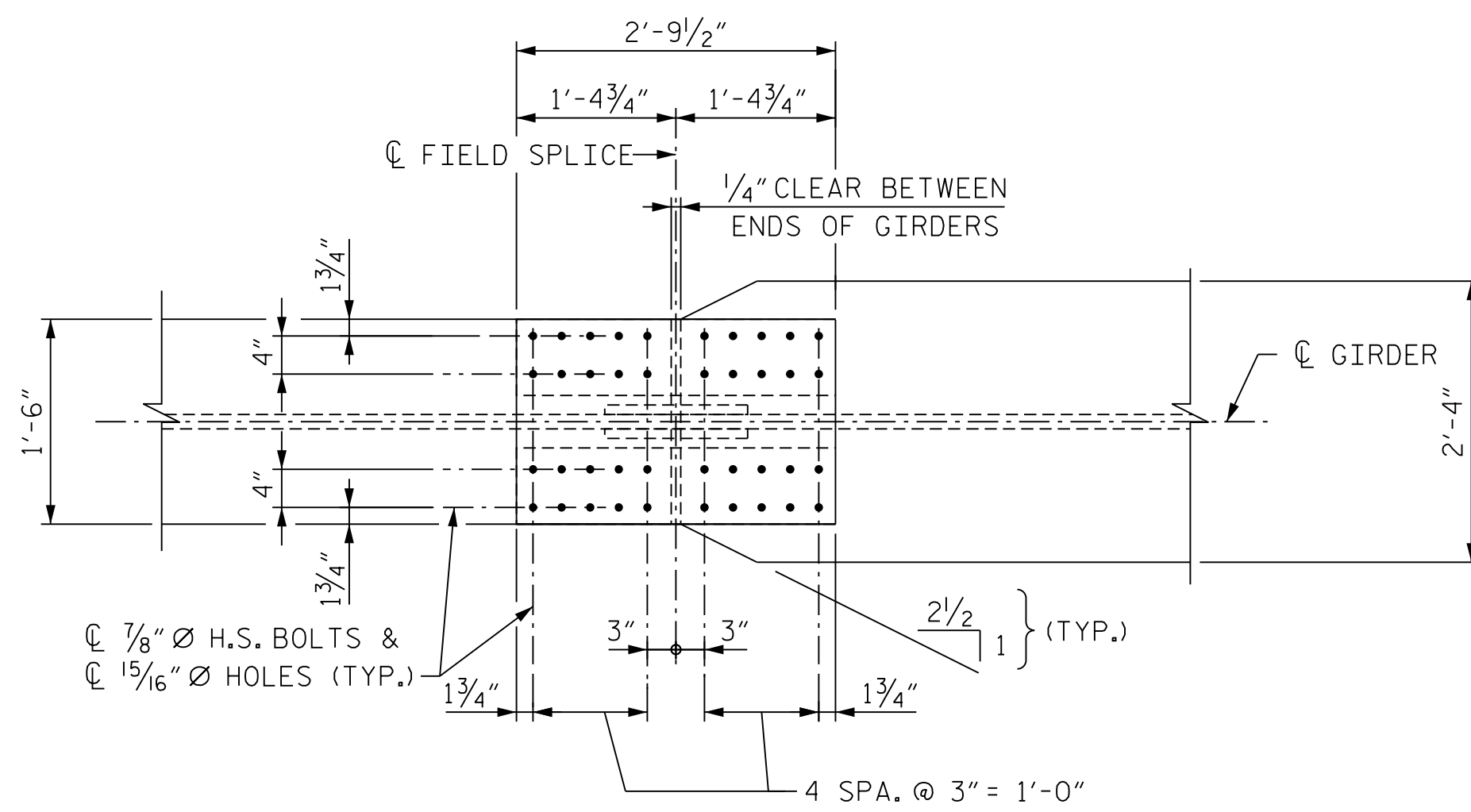

**PLAN (TOP OF TOP FLANGE)**  
(STUDS NOT SHOWN FOR CLARITY)

\* = SHEAR STUDS ARE TO BE SHOP WELDED ON TOP OF PLATE BEFORE FIELD ASSEMBLY

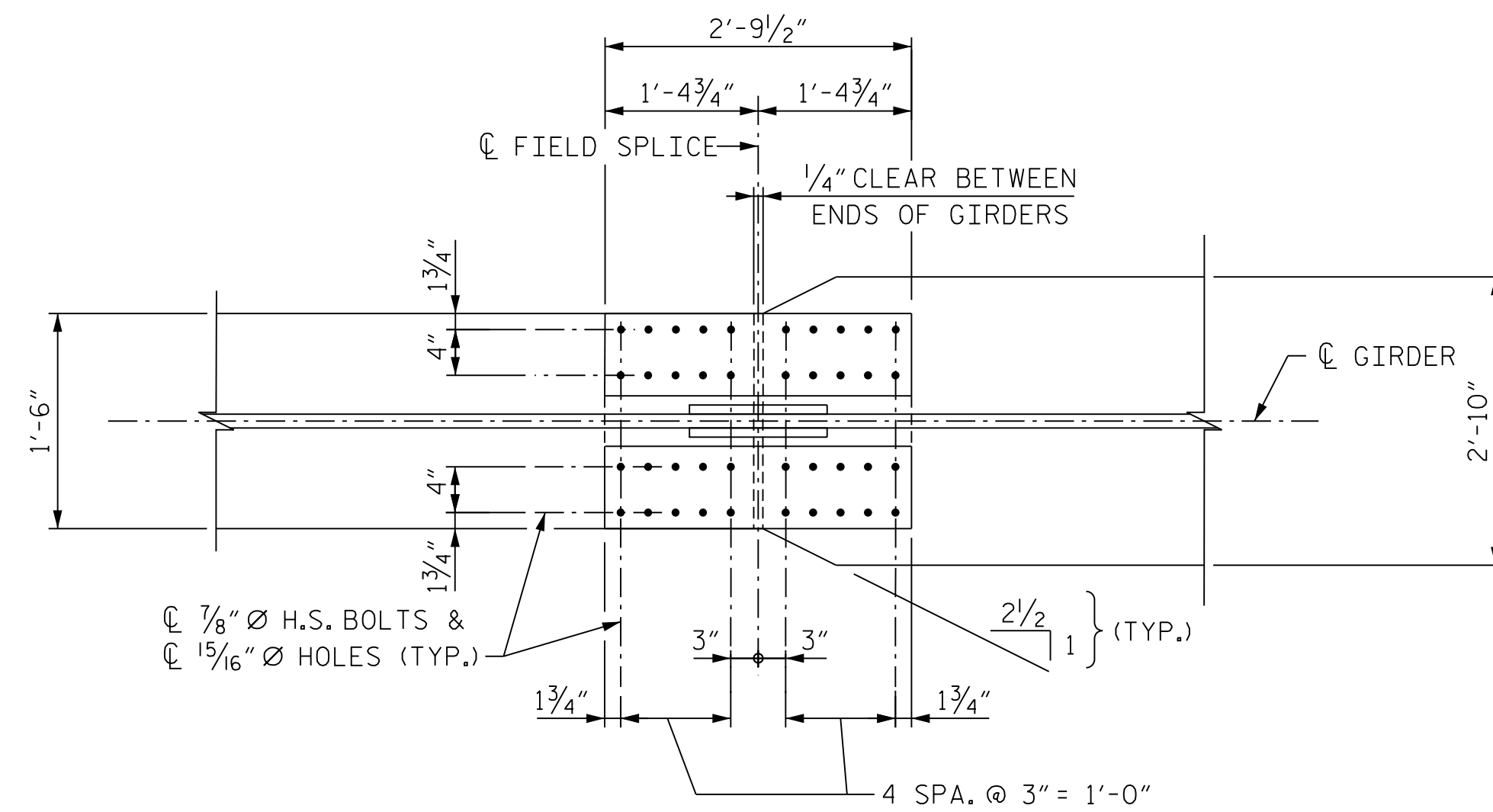

**PLAN (TOP OF BOTTOM FLANGE)**

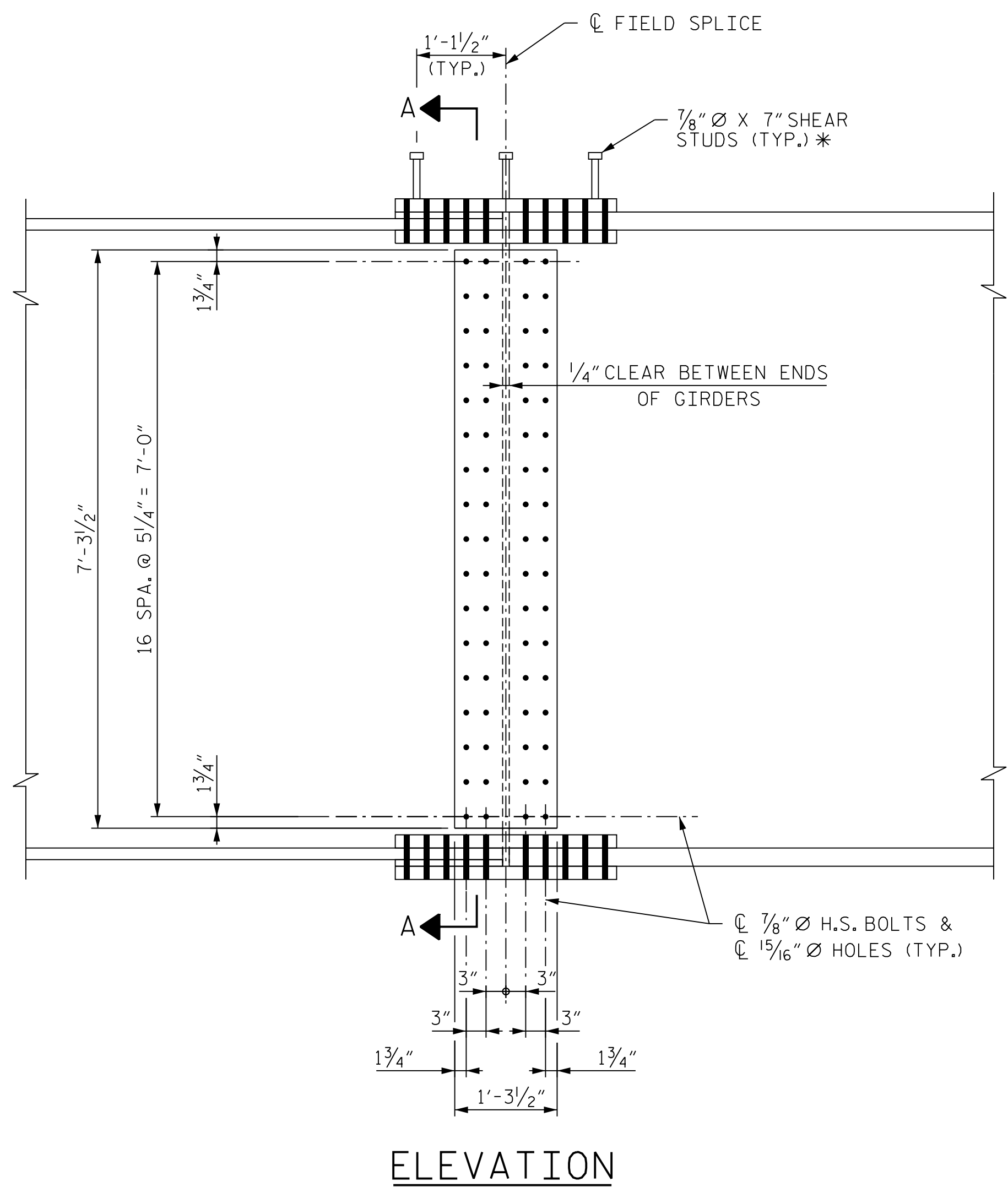

**ELEVATION**

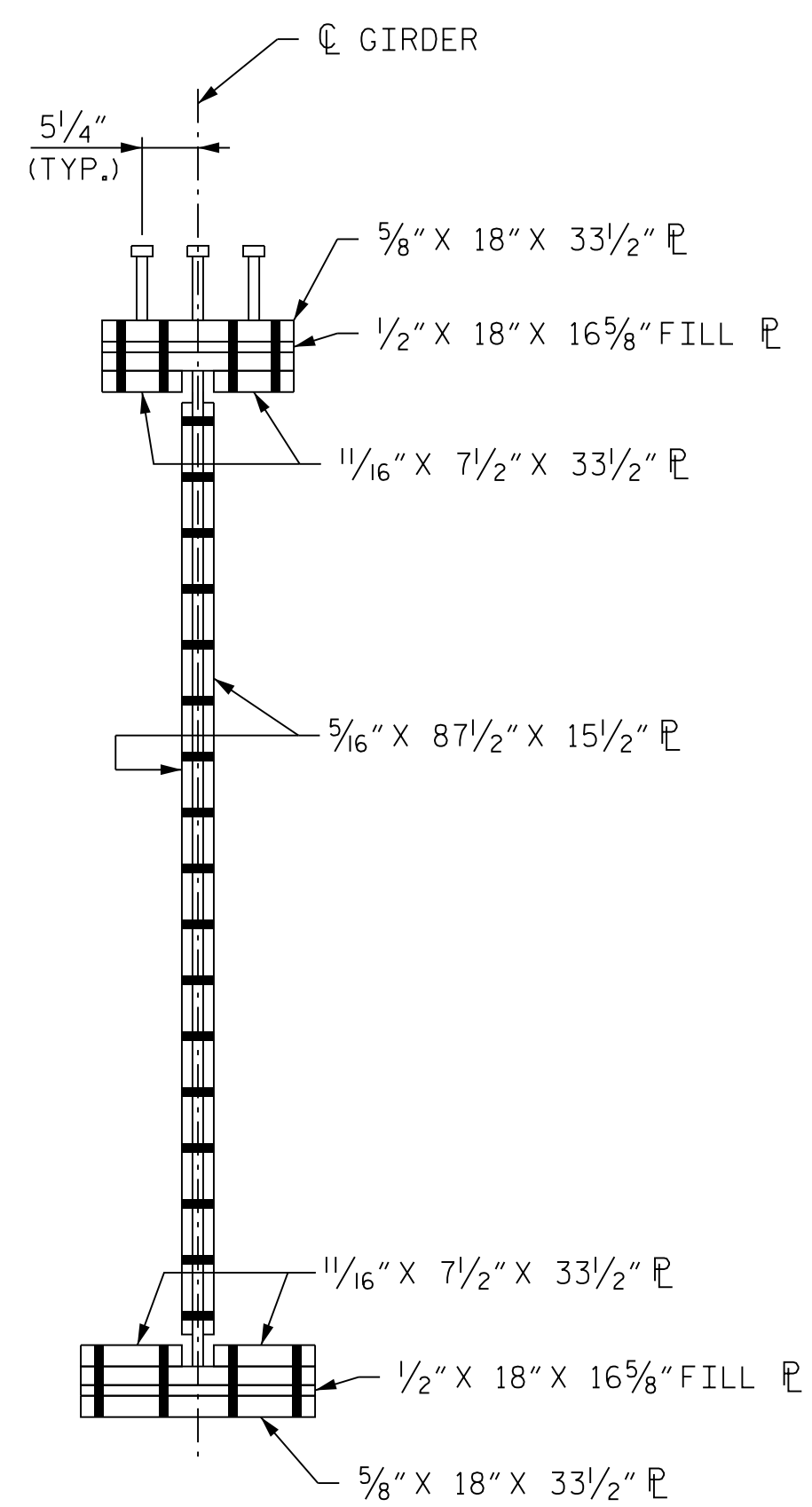

**SECTION A-A**

**NOTE**  
ORIENTATION OF PLAN AND ELEVATION VIEWS MAY VARY BASED ON FIELD SPLICE LOCATION

PROJECT NO. U-2579AB  
FORSYTH COUNTY  
STATION: 60+66.06 -Y15FLYAC-

SHEET 9 OF 19

STATE OF NORTH CAROLINA  
DEPARTMENT OF TRANSPORTATION  
RALEIGH

**SUPERSTRUCTURE  
BOLTED FIELD SPLICE  
DETAILS - TYPE "I"**



*Domenic A. Colletti* 10/15/2021

REVISIONS						SHEET NO. S04-049 TOTAL SHEETS 144
NO.	BY:	DATE:	NO.	BY:	DATE:	
1	--	--	3	--	--	
2	--	--	4	--	--	

**HDR** HDR Engineering, Inc. of the Carolinas  
555 Fayetteville St., Suite 900 Raleigh, N.C. 27601  
N.C.B.E.L.S. License Number: F-0116

**DOCUMENT NOT CONSIDERED FINAL  
UNLESS ALL SIGNATURES COMPLETED**

PLOT DRIVER: NCDOT\_pdf\_color\_eng-50.ppt  
USER: PPETERSO DATE: 10/14/2021  
PENTABLE: NCDOT\_STRUCTURES\_DEFAULT\_PEN.tbl  
TIME: 4:01:51 PM  
FILE: ... \SUPERS

DES BY: <u>G. SCHMITZ</u>	DATE: <u>07/19</u>	DWG BY: <u>B. PETERSON</u>	DATE: <u>07/19</u>
DES CHK: <u>D. OLDS</u>	DATE: <u>08/19</u>	CHK BY: <u>T. ANDREWS</u>	DATE: <u>10/19</u>

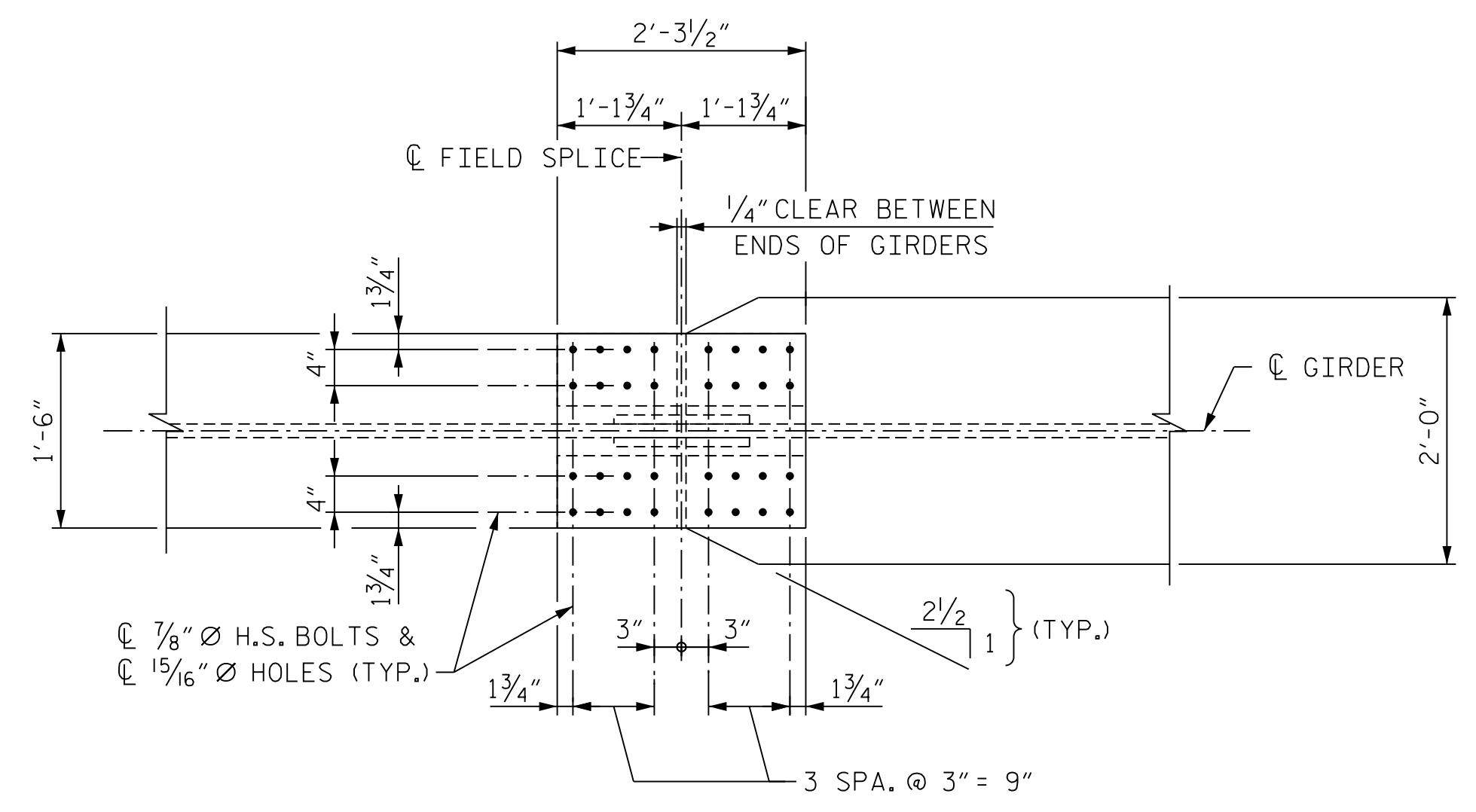

**PLAN (TOP OF TOP FLANGE)**  
(STUDS NOT SHOWN FOR CLARITY)

\* = SHEAR STUDS ARE TO BE SHOP WELDED ON TOP OF PLATE BEFORE FIELD ASSEMBLY

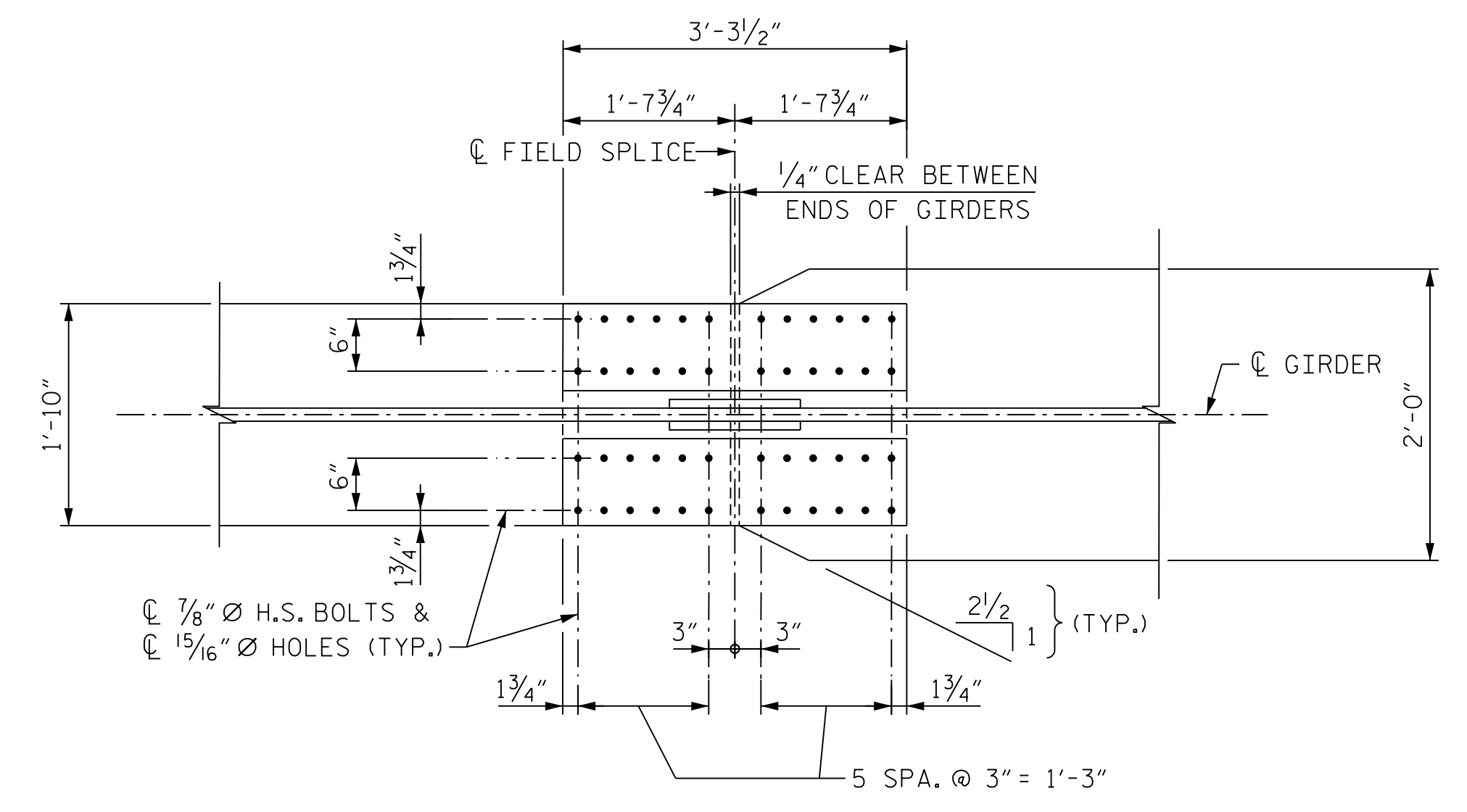

**PLAN (TOP OF BOTTOM FLANGE)**

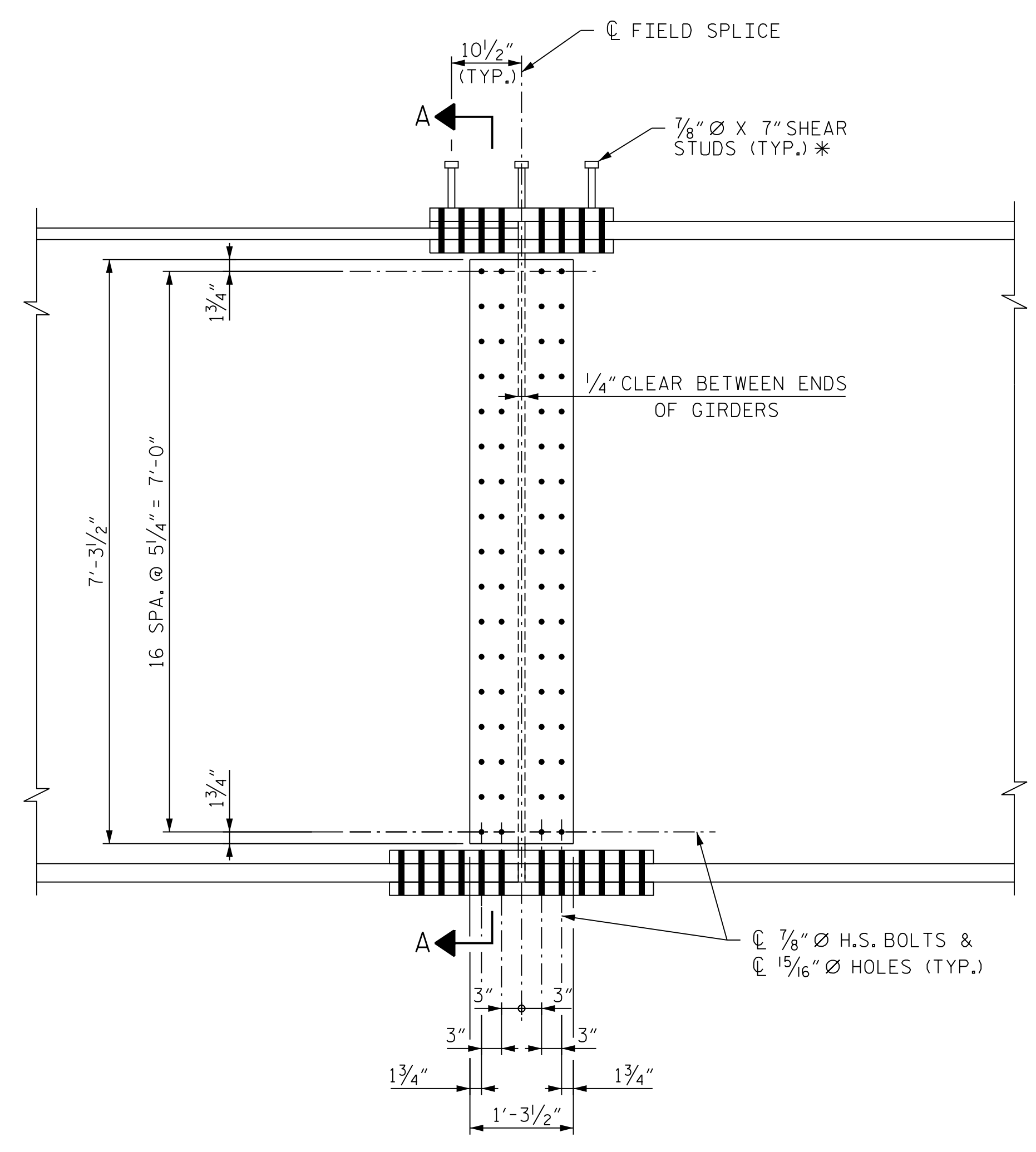

**ELEVATION**

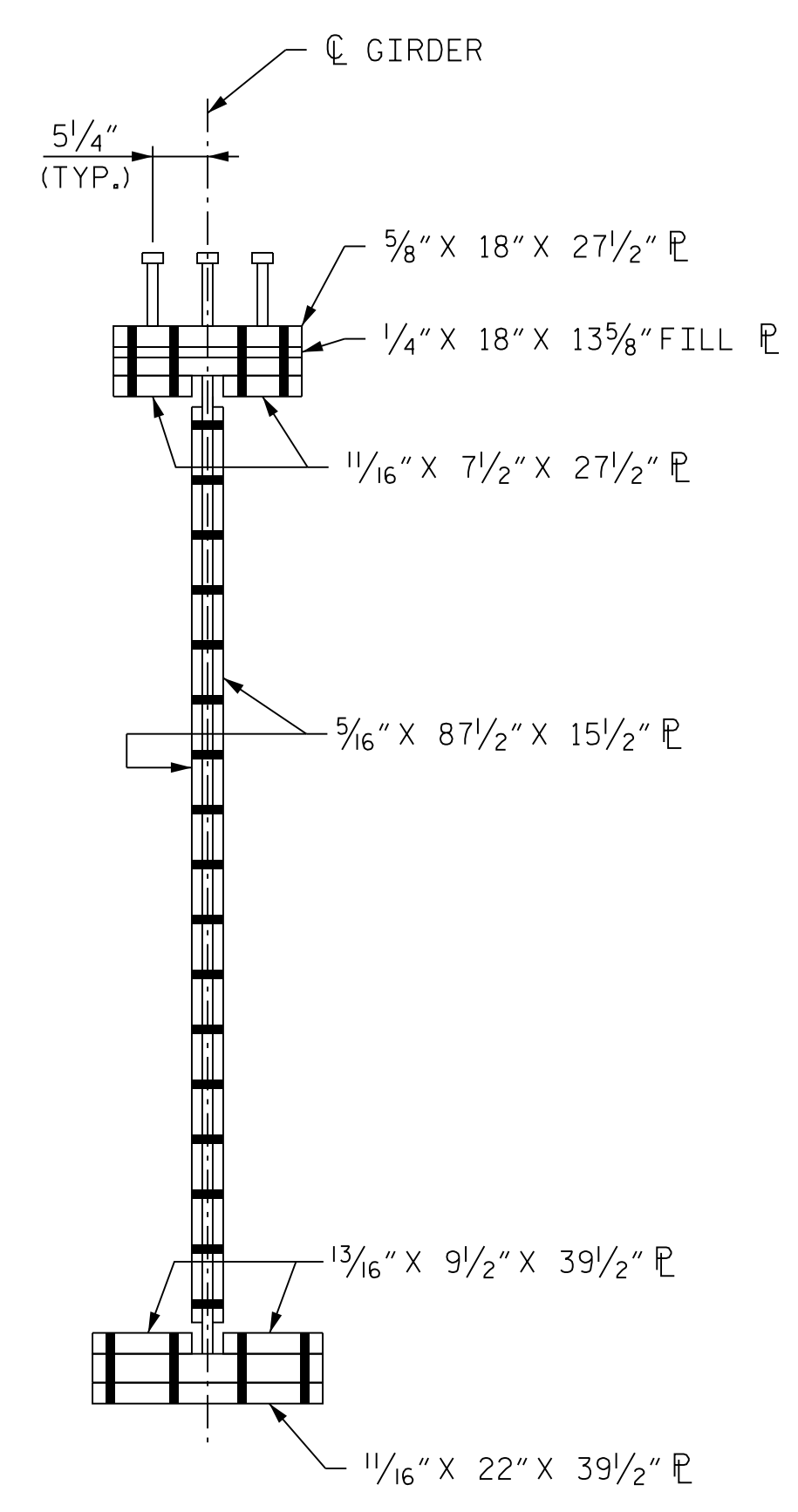

**SECTION A-A**

**NOTE**  
ORIENTATION OF PLAN AND ELEVATION VIEWS MAY VARY BASED ON FIELD SPLICE LOCATION

PROJECT NO. U-2579AB  
FORSYTH COUNTY  
 STATION: 60+66.06 -Y15FLYAC-  
 SHEET 10 OF 19



10/15/2021

STATE OF NORTH CAROLINA  
 DEPARTMENT OF TRANSPORTATION  
 RALEIGH

**SUPERSTRUCTURE  
 BOLTED FIELD SPLICE  
 DETAILS - TYPE "J"**

REVISIONS						SHEET NO. SD4-050 TOTAL SHEETS 144
NO.	BY:	DATE:	NO.	BY:	DATE:	
1	--	--	3	--	--	
2	--	--	4	--	--	

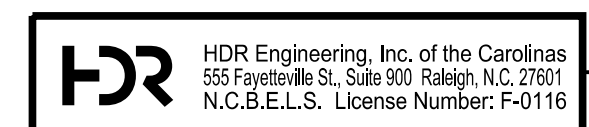

**DOCUMENT NOT CONSIDERED FINAL  
 UNLESS ALL SIGNATURES COMPLETED**

PLOT DRIVER: NCDOT... PENTABLE: NCDOT STRUCTURES DEFAULT PEN.tbl  
 USER: PPETERSO DATE: 10/14/2021 TIME: 4:01:53 PM  
 FILE: ... \SUPERS

DES BY: <u>G. SCHMITZ</u>	DATE: <u>07/19</u>	DWG BY: <u>B. PETERSON</u>	DATE: <u>07/19</u>
DES CHK: <u>D. OLDS</u>	DATE: <u>08/19</u>	CHK BY: <u>T. ANDREWS</u>	DATE: <u>10/19</u>

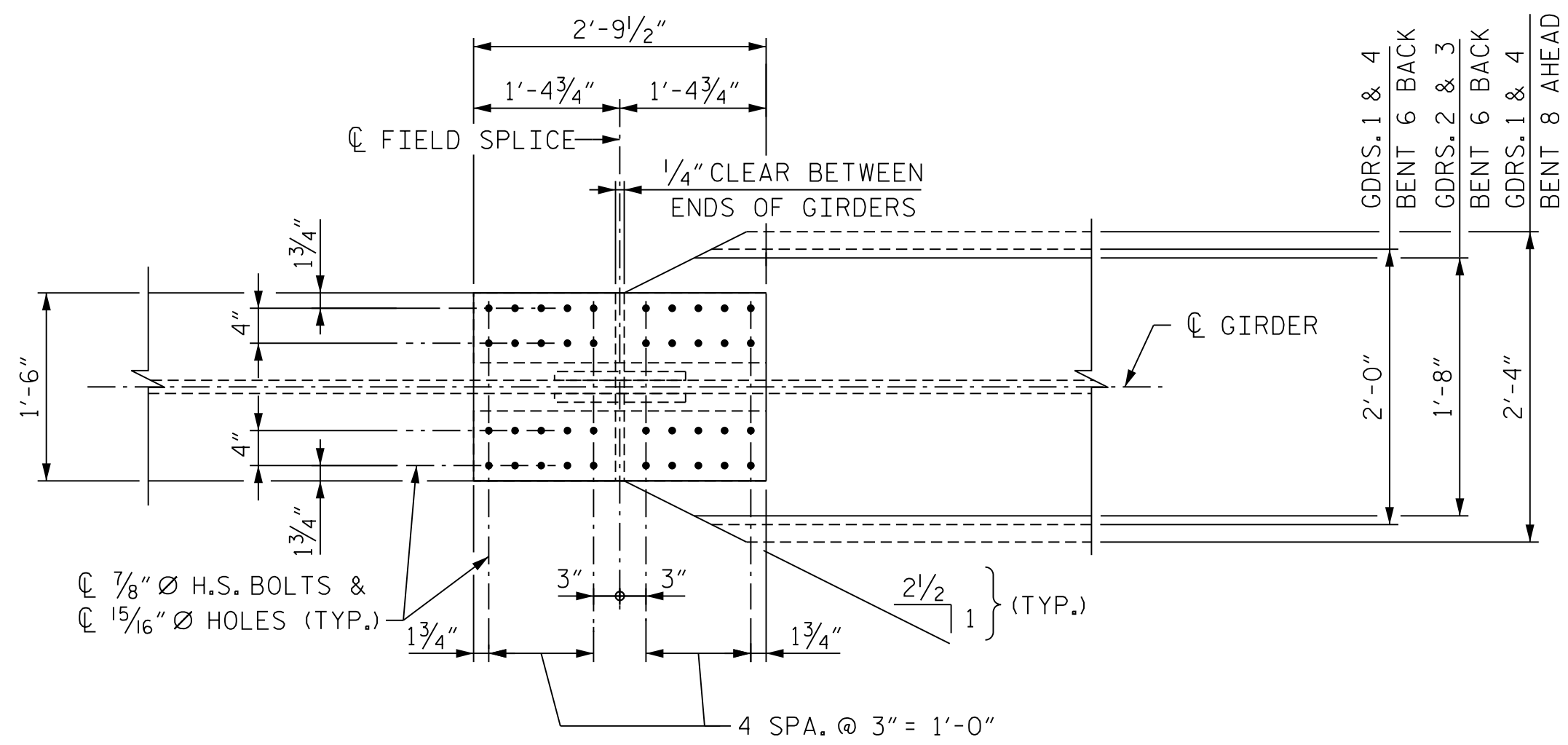

PLAN (TOP OF TOP FLANGE)

(STUDS NOT SHOWN FOR CLARITY)

\* = SHEAR STUDS ARE TO BE SHOP WELDED ON TOP OF PLATE BEFORE FIELD ASSEMBLY

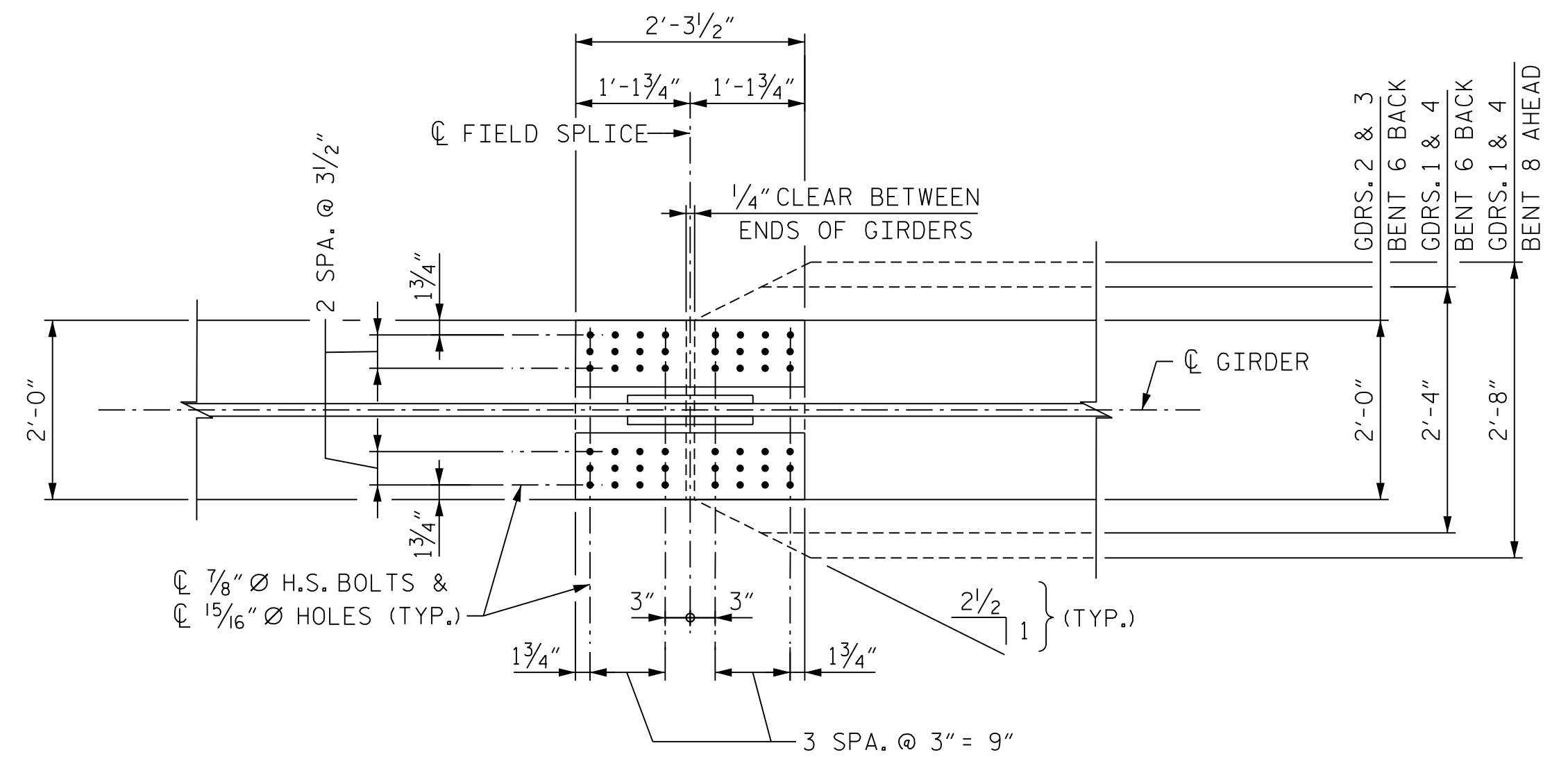

PLAN (TOP OF BOTTOM FLANGE)

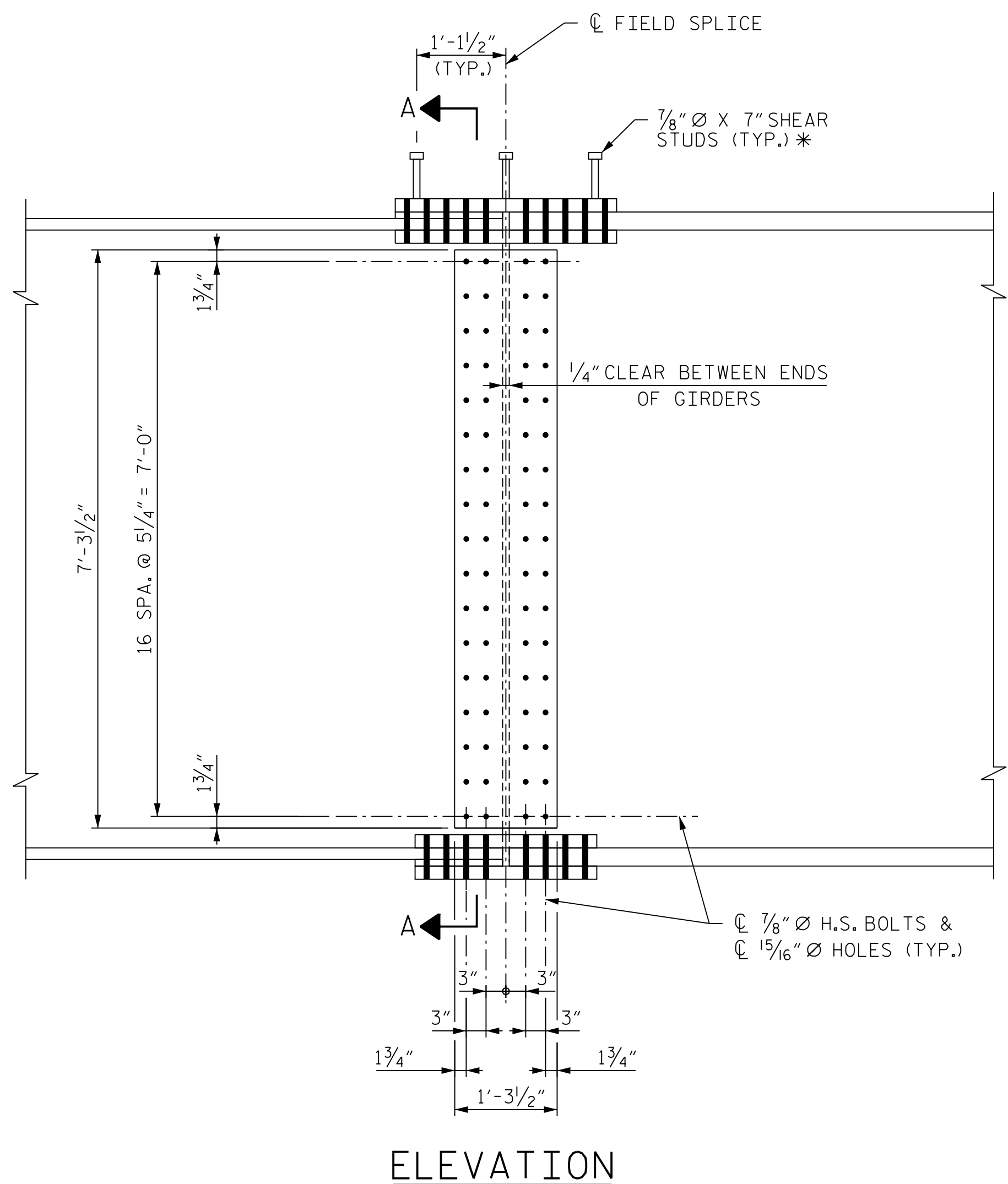

ELEVATION

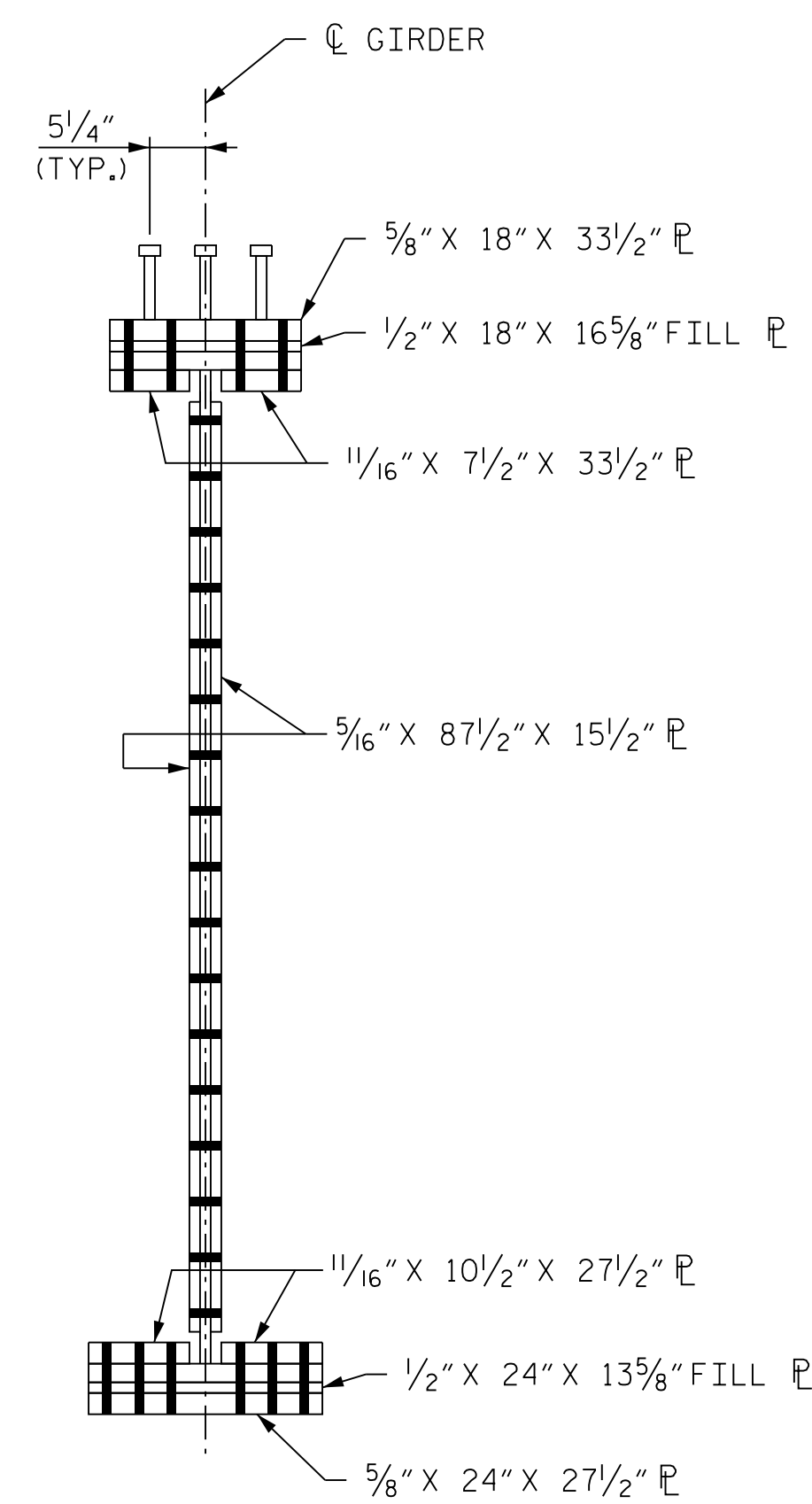

SECTION A-A

NOTE  
ORIENTATION OF PLAN AND ELEVATION VIEWS MAY VARY BASED ON FIELD SPLICE LOCATION

PROJECT NO. U-2579AB  
FORSYTH COUNTY  
 STATION: 60+66.06 -Y15FLYAC-

SHEET 11 OF 19

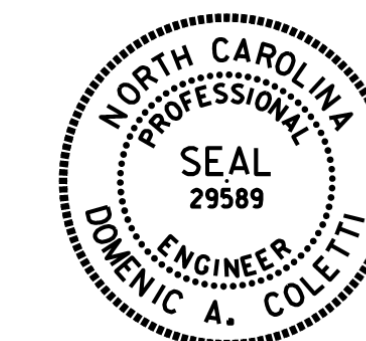

10/15/2021

STATE OF NORTH CAROLINA  
 DEPARTMENT OF TRANSPORTATION  
 RALEIGH  
 SUPERSTRUCTURE  
 BOLTED FIELD SPLICE  
 DETAILS - TYPE "K"

REVISIONS						SHEET NO.	
NO.	BY:	DATE:	NO.	BY:	DATE:	SHEET NO.	
1	--	--	3	--	--	TOTAL SHEETS	
2	--	--	4	--	--	144	



DOCUMENT NOT CONSIDERED FINAL  
 UNLESS ALL SIGNATURES COMPLETED

PLOT DRIVER: NCDOT... PENTABLE: NCDOT STRUCTURES DEFAULT PEN.tbl  
 USER: PPETERSO DATE: 10/14/2021 TIME: 4:01:54 PM  
 FILE: ... \SUPERS

DES BY: T. ANDREWS	DATE: 07/19	DWG BY: B. PETERSON	DATE: 07/19
DES CHK: D. OLDS	DATE: 08/19	CHK BY: T. ANDREWS	DATE: 10/19

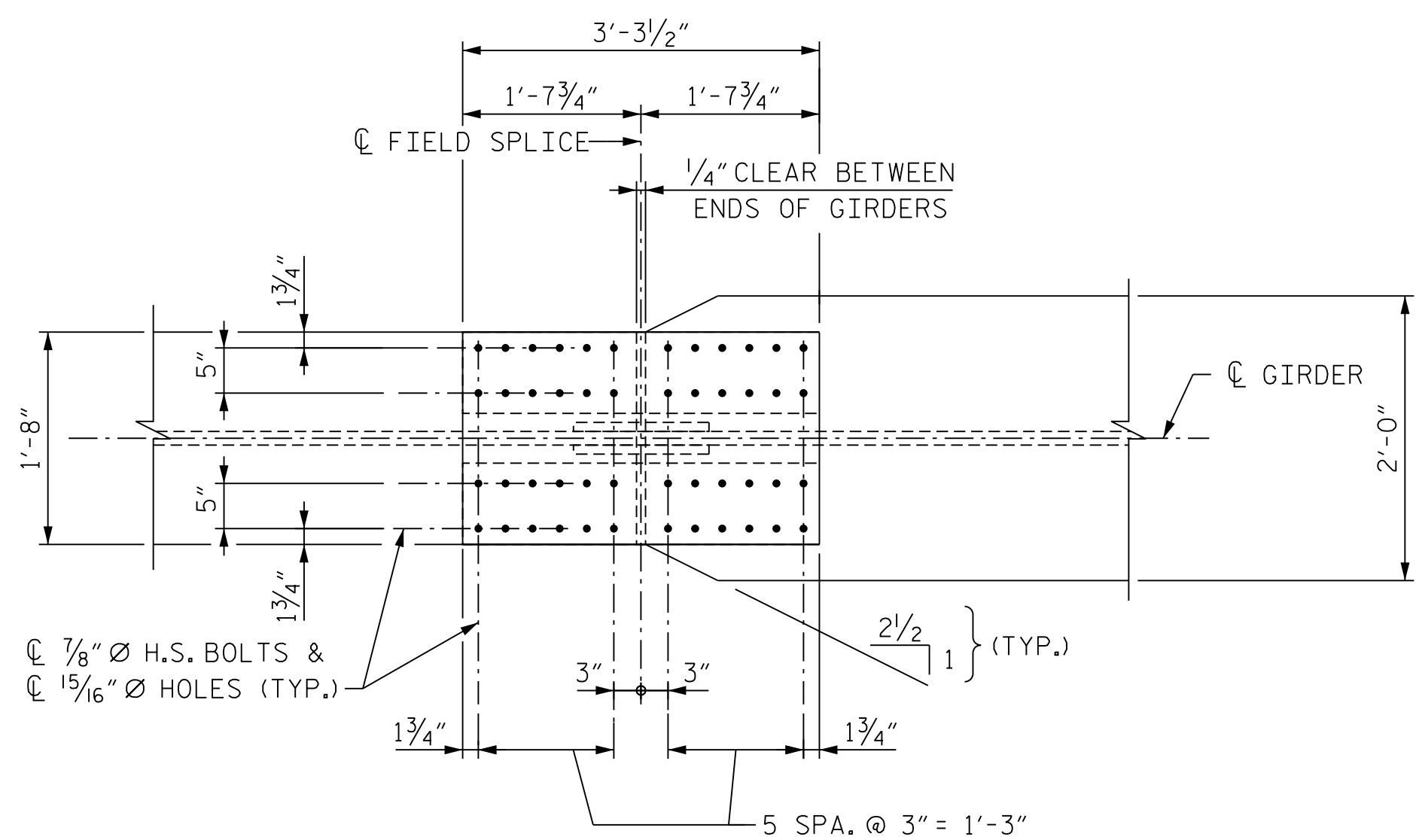

**PLAN (TOP OF TOP FLANGE)**

(STUDS NOT SHOWN FOR CLARITY)

\* = SHEAR STUDS ARE TO BE SHOP WELDED ON TOP OF PLATE BEFORE FIELD ASSEMBLY

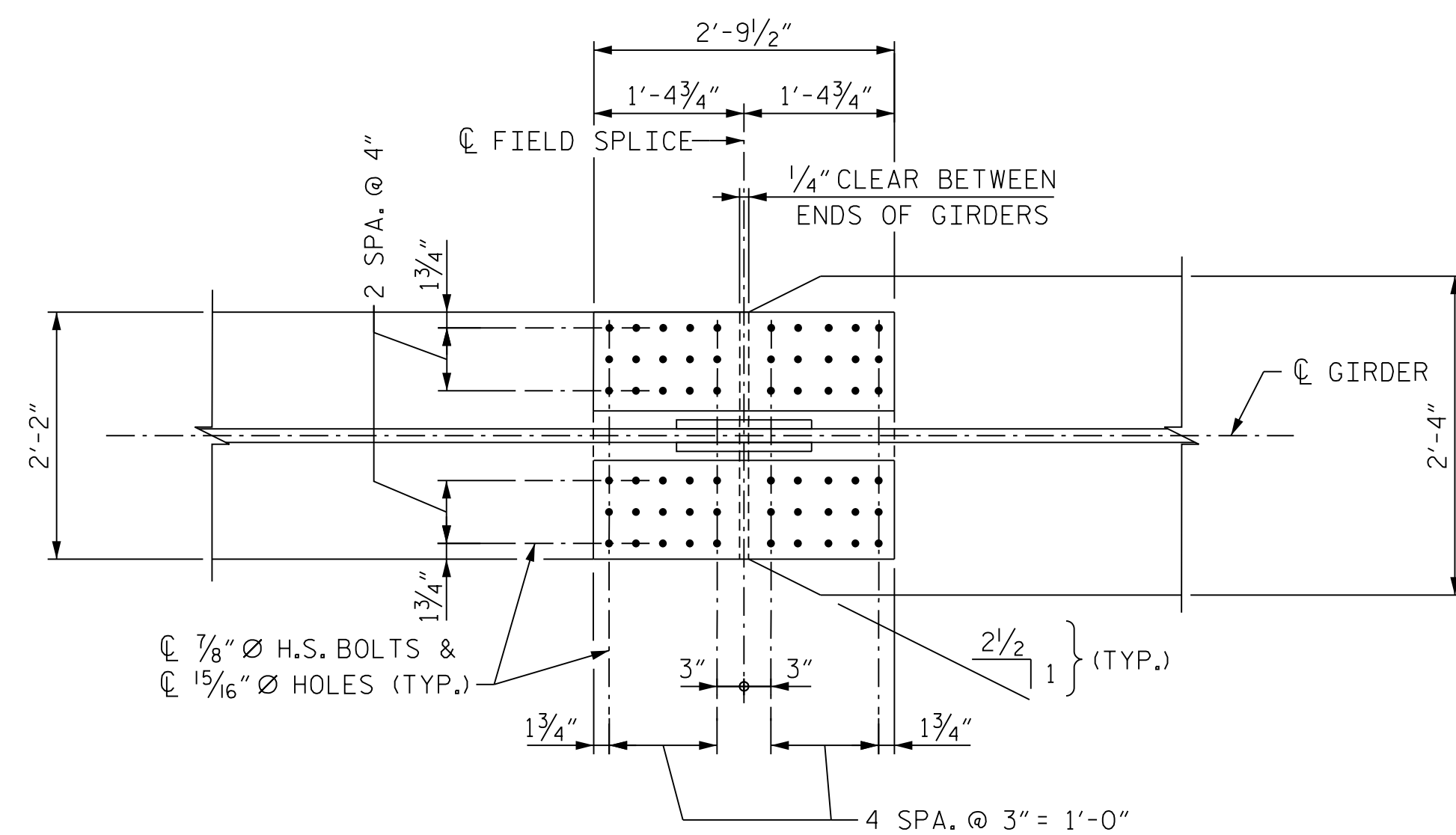

**PLAN (TOP OF BOTTOM FLANGE)**

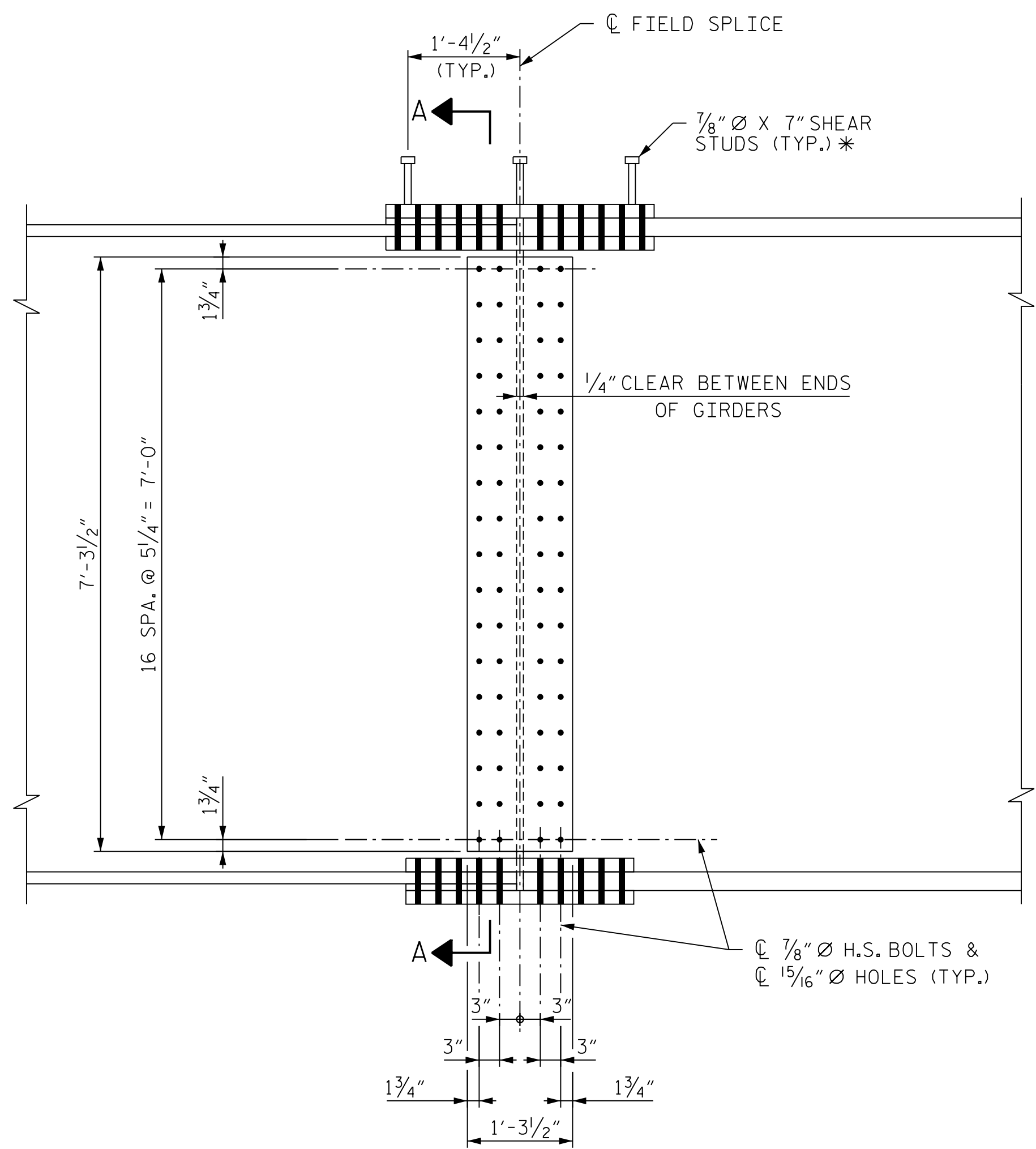

**ELEVATION**

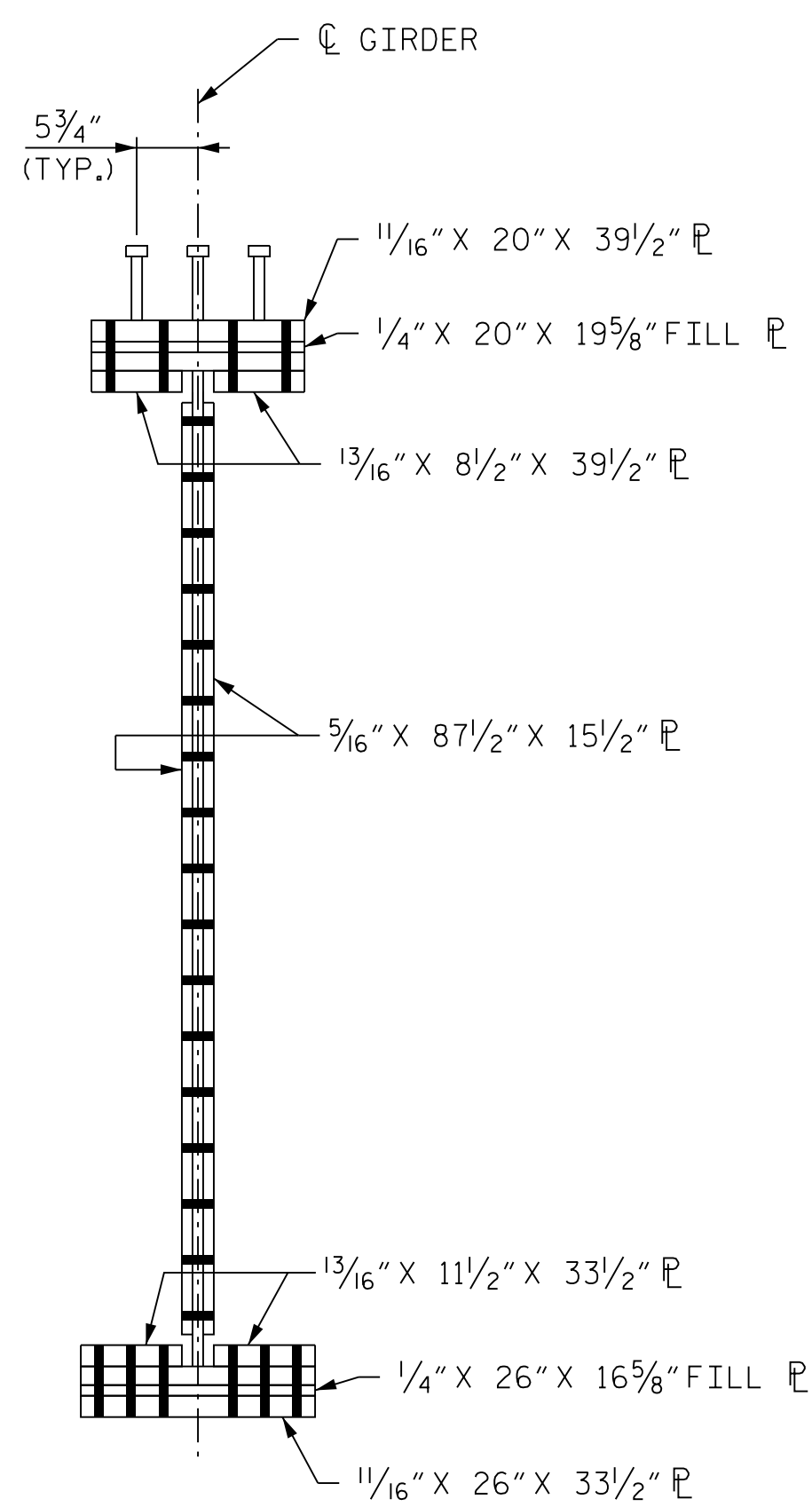

**SECTION A-A**

**NOTE**  
ORIENTATION OF PLAN AND ELEVATION VIEWS MAY VARY BASED ON FIELD SPLICE LOCATION

PROJECT NO. U-2579AB  
FORSYTH COUNTY  
STATION: 60+66.06 -Y15FLYAC-

SHEET 12 OF 19



10/15/2021

STATE OF NORTH CAROLINA  
DEPARTMENT OF TRANSPORTATION  
RALEIGH  
**SUPERSTRUCTURE  
BOLTED FIELD SPLICE  
DETAILS - TYPE "L"**

REVISIONS						SHEET NO. S04-052 TOTAL SHEETS 144
NO.	BY:	DATE:	NO.	BY:	DATE:	
1	--	--	3	--	--	
2	--	--	4	--	--	

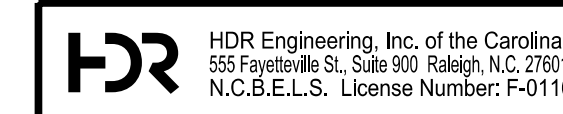

DOCUMENT NOT CONSIDERED FINAL UNLESS ALL SIGNATURES COMPLETED

PLOT DRIVER: NCDOT\_pdf\_color\_eng-50.ppt  
 USER: PPETERSO DATE: 10/14/2021  
 PENTABLE: NCDOT\_STRUCTURES\_DEFAULT\_PEN.tbl  
 TIME: 4:01:55 PM  
 FILE: ... \SUPERS

DES BY: <u>T. ANDREWS</u>	DATE: <u>07/19</u>	DWG BY: <u>B. PETERSON</u>	DATE: <u>07/19</u>
DES CHK: <u>D. OLDS</u>	DATE: <u>08/19</u>	CHK BY: <u>T. ANDREWS</u>	DATE: <u>10/19</u>



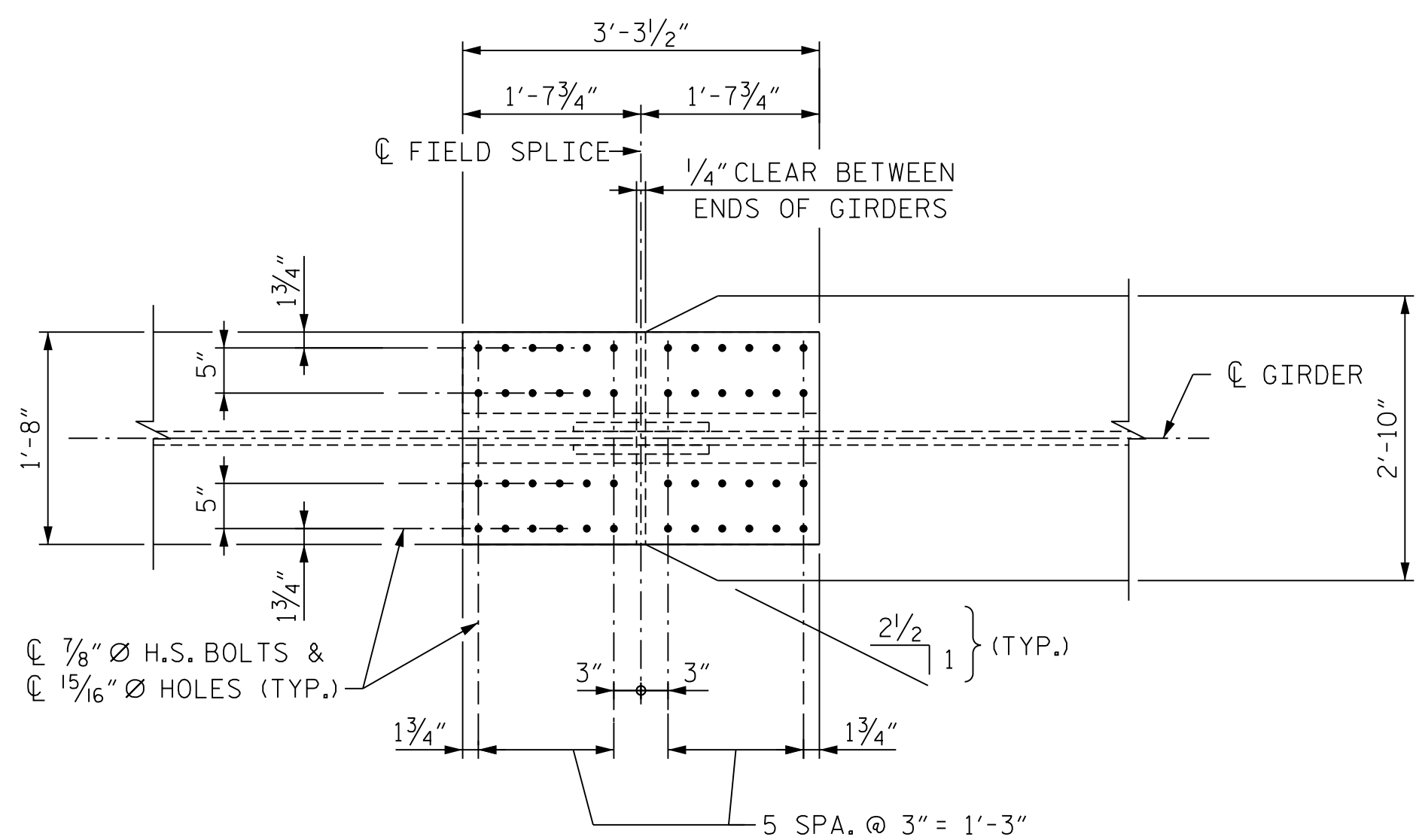

**PLAN (TOP OF TOP FLANGE)**

(STUDS NOT SHOWN FOR CLARITY)

\* = SHEAR STUDS ARE TO BE SHOP WELDED ON TOP OF PLATE BEFORE FIELD ASSEMBLY

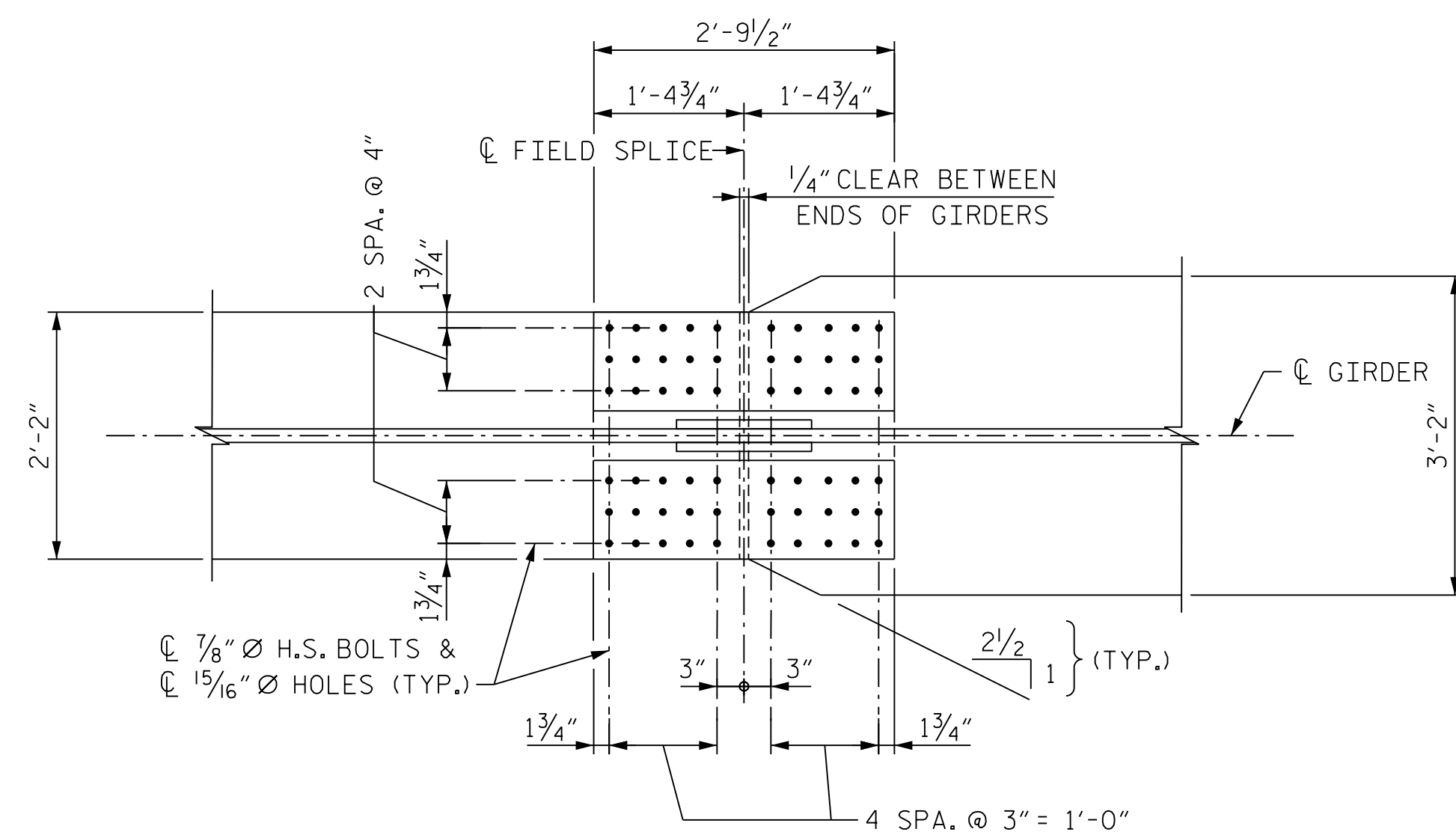

**PLAN (TOP OF BOTTOM FLANGE)**

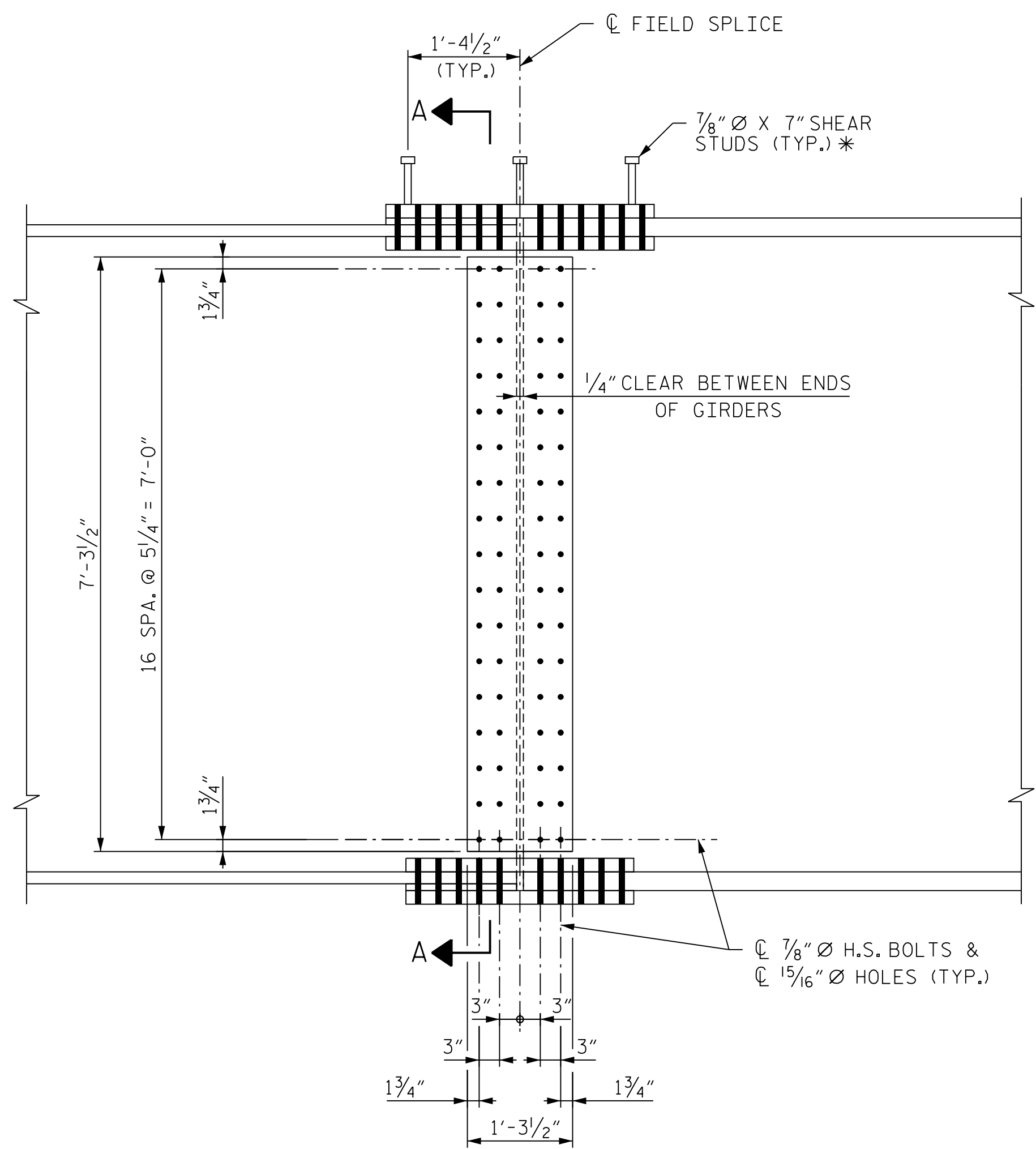

**ELEVATION**

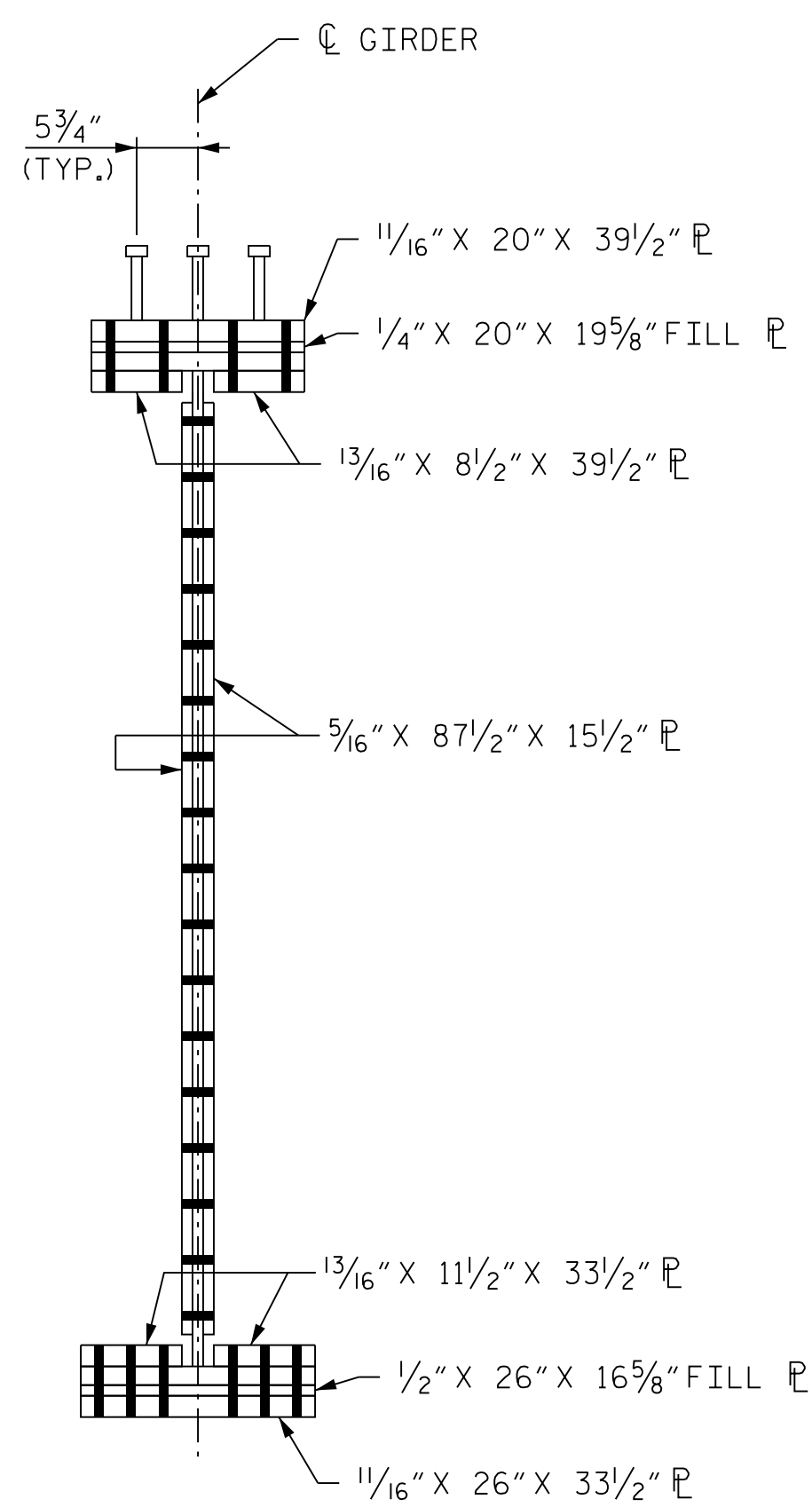

**SECTION A-A**

**NOTE**  
ORIENTATION OF PLAN AND ELEVATION VIEWS MAY VARY BASED ON FIELD SPLICE LOCATION

PROJECT NO. U-2579AB  
FORSYTH COUNTY  
STATION: 60+66.06 -Y15FLYAC-

SHEET 13 OF 19

STATE OF NORTH CAROLINA  
DEPARTMENT OF TRANSPORTATION  
RALEIGH

**SUPERSTRUCTURE  
BOLTED FIELD SPLICE  
DETAILS - TYPE "M"**



10/15/2021

REVISIONS

NO.	BY:	DATE:	NO.	BY:	DATE:
1	--	--	3	--	--
2	--	--	4	--	--

SHEET NO. S04-053  
TOTAL SHEETS 144

PLOT DRIVER: NCDOT... PENTABLE: NCDOT STRUCTURES DEFAULT PEN.tbl  
USER: PPETERSO DATE: 10/14/2021 TIME: 4:01:56 PM  
FILE: ... \SUPERS

DES BY: T. ANDREWS DATE: 07/19  
DES CHK: D. OLDS DATE: 08/19  
DWG BY: B. PETERSON DATE: 07/19  
CHK BY: T. ANDREWS DATE: 10/19

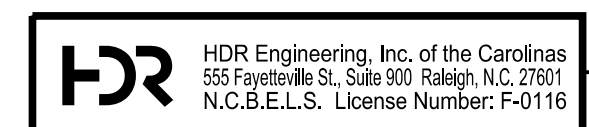

DOCUMENT NOT CONSIDERED FINAL  
UNLESS ALL SIGNATURES COMPLETED

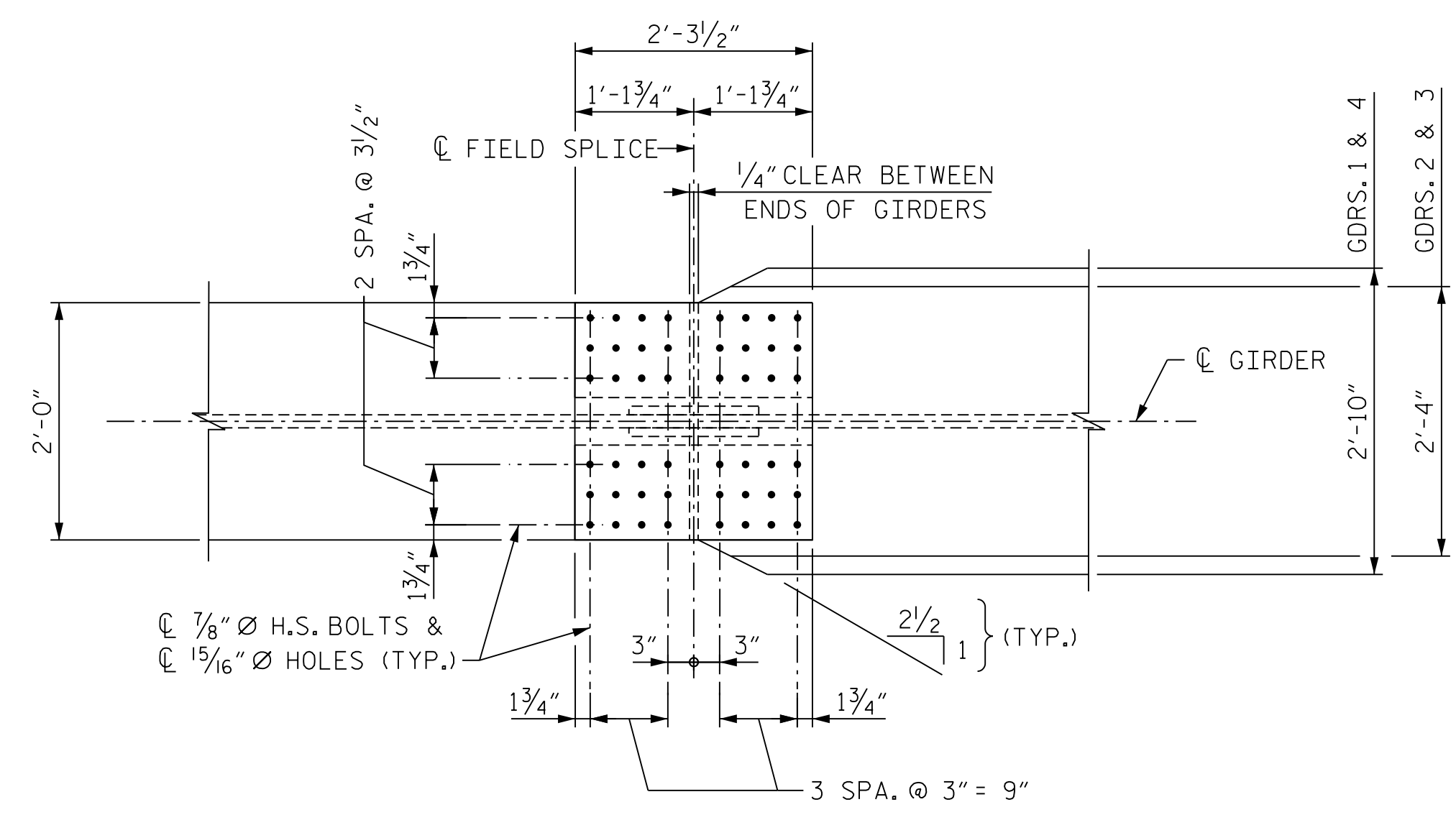

**PLAN (TOP OF TOP FLANGE)**  
(STUDS NOT SHOWN FOR CLARITY)

\* = SHEAR STUDS ARE TO BE SHOP WELDED ON TOP OF PLATE BEFORE FIELD ASSEMBLY

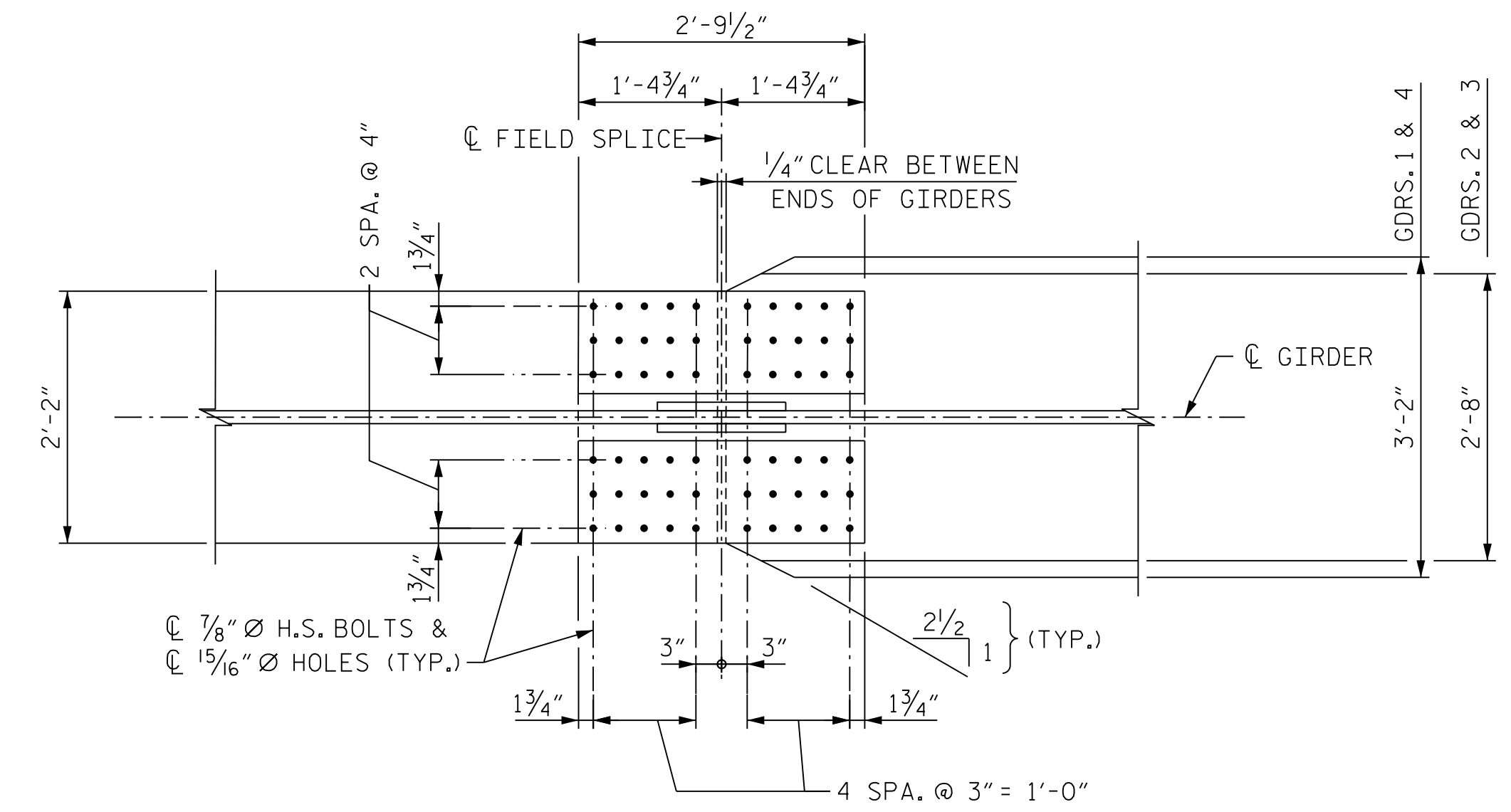

**PLAN (TOP OF BOTTOM FLANGE)**

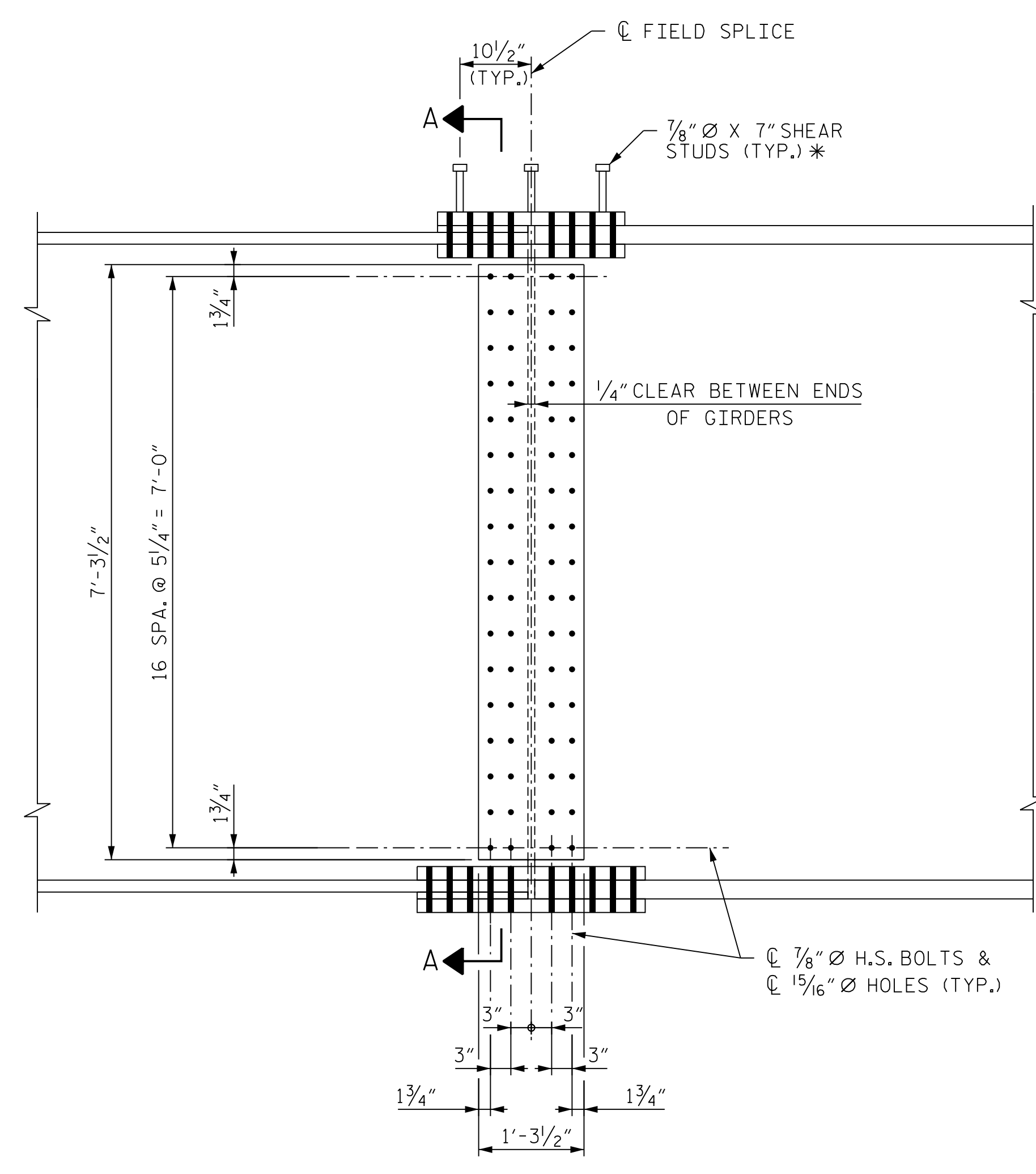

**ELEVATION**

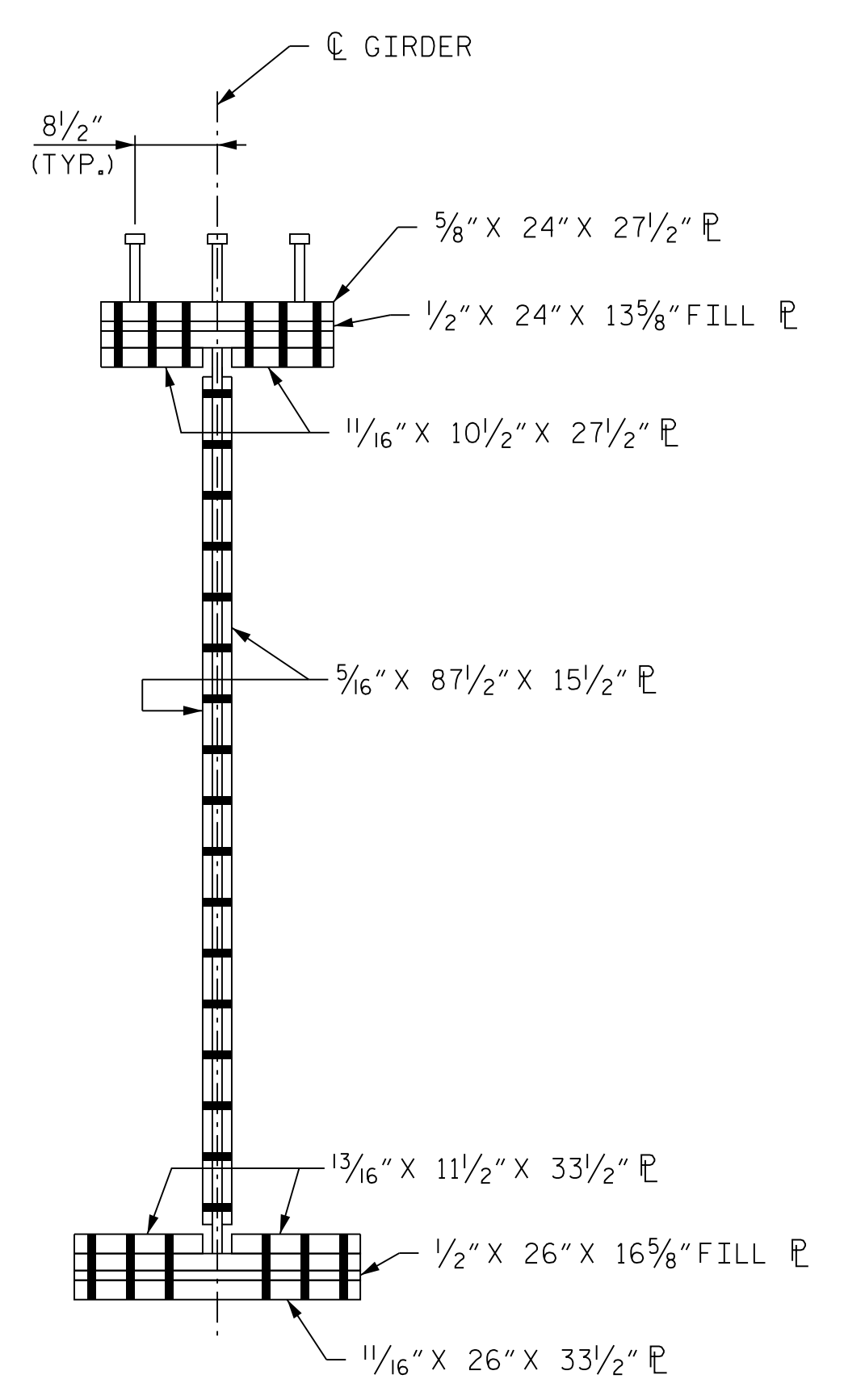

**SECTION A-A**

**NOTE**  
ORIENTATION OF PLAN AND ELEVATION VIEWS MAY VARY BASED ON FIELD SPLICE LOCATION

PROJECT NO. U-2579AB  
FORSYTH COUNTY  
 STATION: 60+66.06 -Y15FLYAC-  
 SHEET 14 OF 19



*Dominic A. Colletti* 10/15/2021

STATE OF NORTH CAROLINA  
 DEPARTMENT OF TRANSPORTATION  
 RALEIGH

**SUPERSTRUCTURE  
 BOLTED FIELD SPLICE  
 DETAILS - TYPE "N"**

REVISIONS						SHEET NO. S04-054 TOTAL SHEETS 144
NO.	BY:	DATE:	NO.	BY:	DATE:	
1	--	--	3	--	--	
2	--	--	4	--	--	

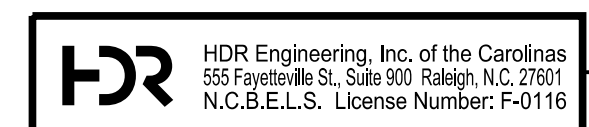

**DOCUMENT NOT CONSIDERED FINAL  
 UNLESS ALL SIGNATURES COMPLETED**

PLOT DRIVER: NCDOT\_pdf\_color\_eng-50.ppt  
 USER: PPETERSO DATE: 10/14/2021  
 PENTABLE: NCDOT\_STRUCTURES\_DEFAULT\_PEN.tbl  
 TIME: 4:01:58 PM  
 FILE: ... \SUPERS

DES BY: <u>T. ANDREWS</u>	DATE: <u>07/19</u>	DWG BY: <u>B. PETERSON</u>	DATE: <u>07/19</u>
DES CHK: <u>D. OLDS</u>	DATE: <u>08/19</u>	CHK BY: <u>T. ANDREWS</u>	DATE: <u>10/19</u>

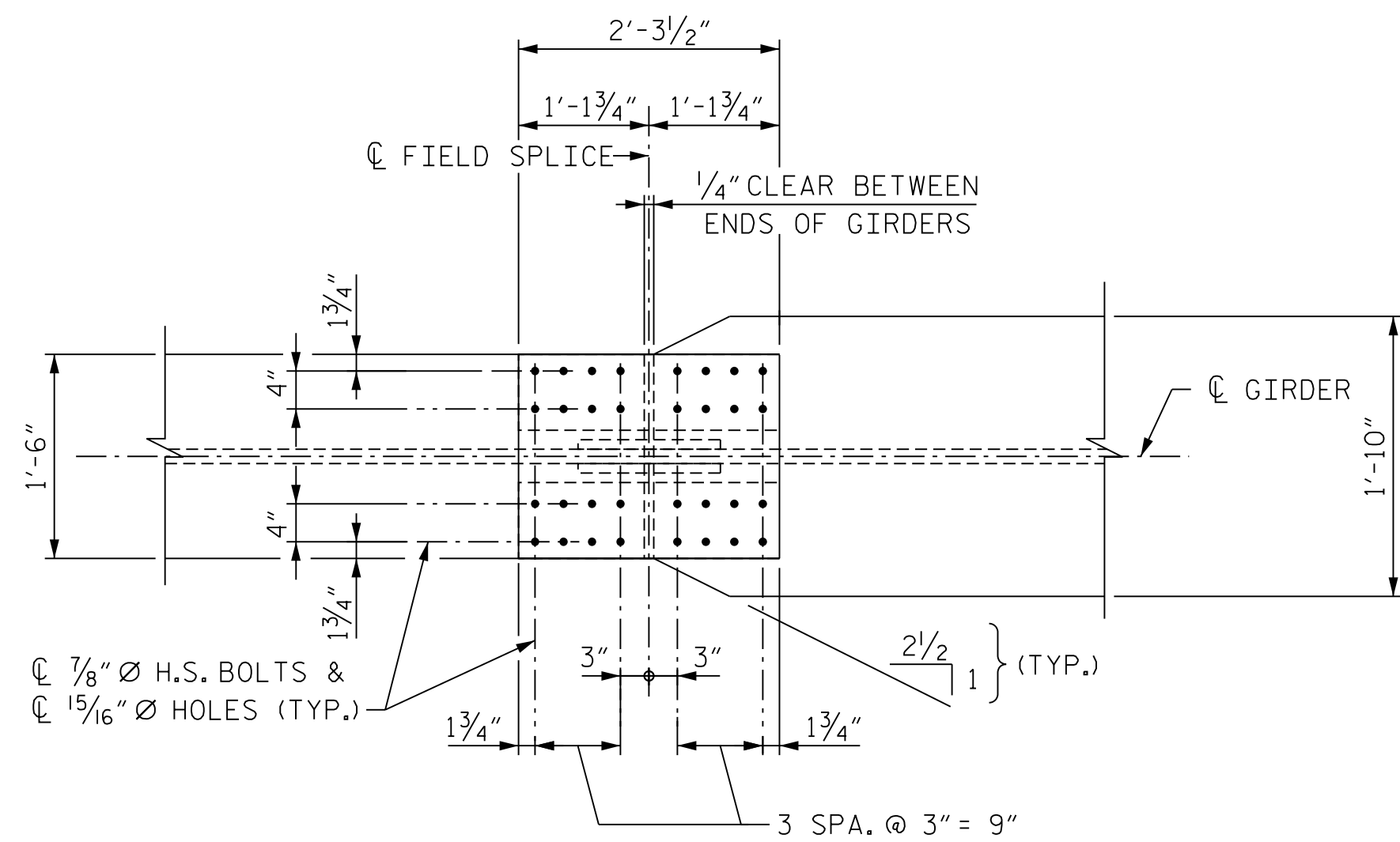

**PLAN (TOP OF TOP FLANGE)**

(STUDS NOT SHOWN FOR CLARITY)

\* = SHEAR STUDS ARE TO BE SHOP WELDED ON TOP OF PLATE BEFORE FIELD ASSEMBLY

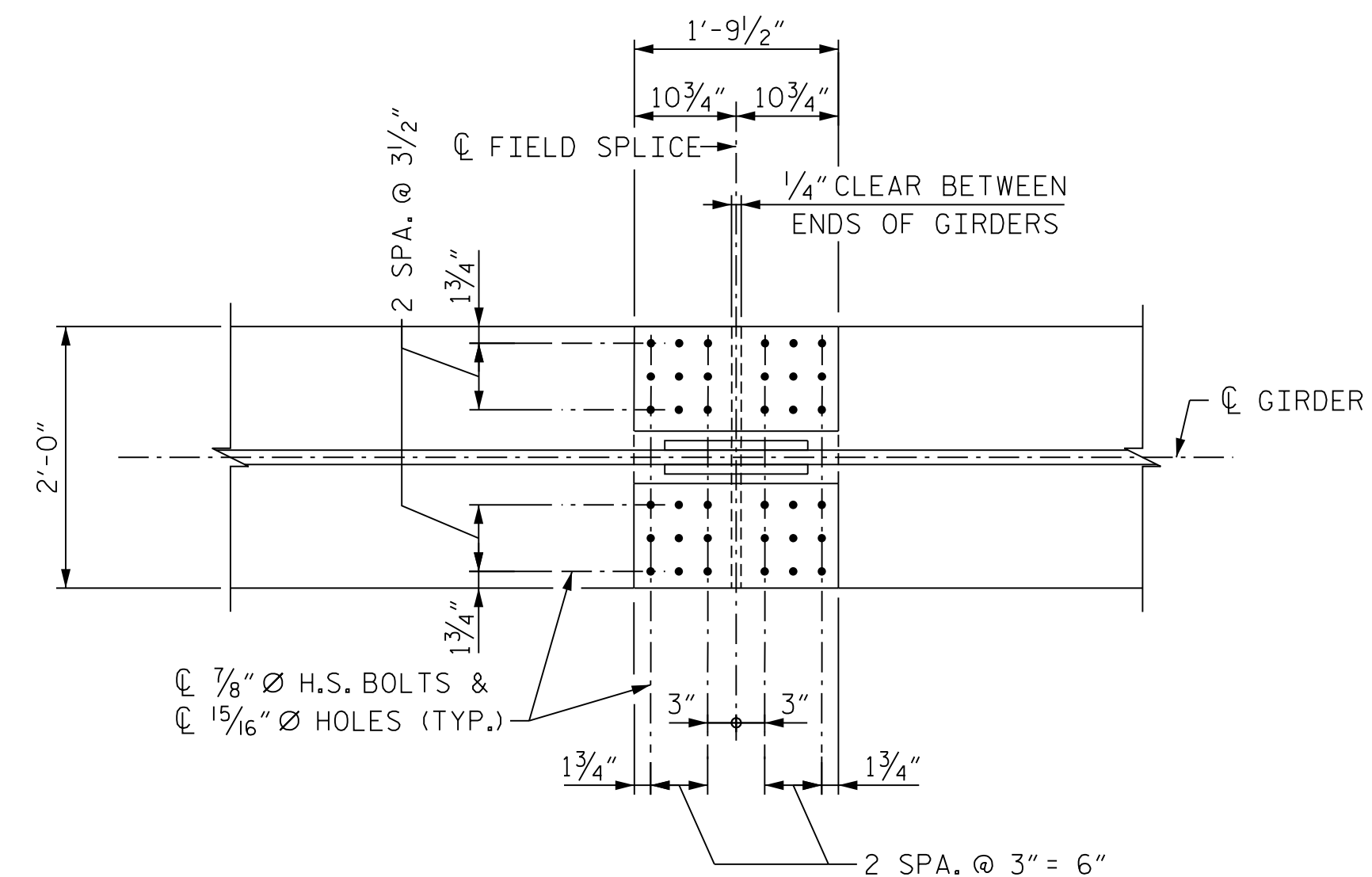

**PLAN (TOP OF BOTTOM FLANGE)**

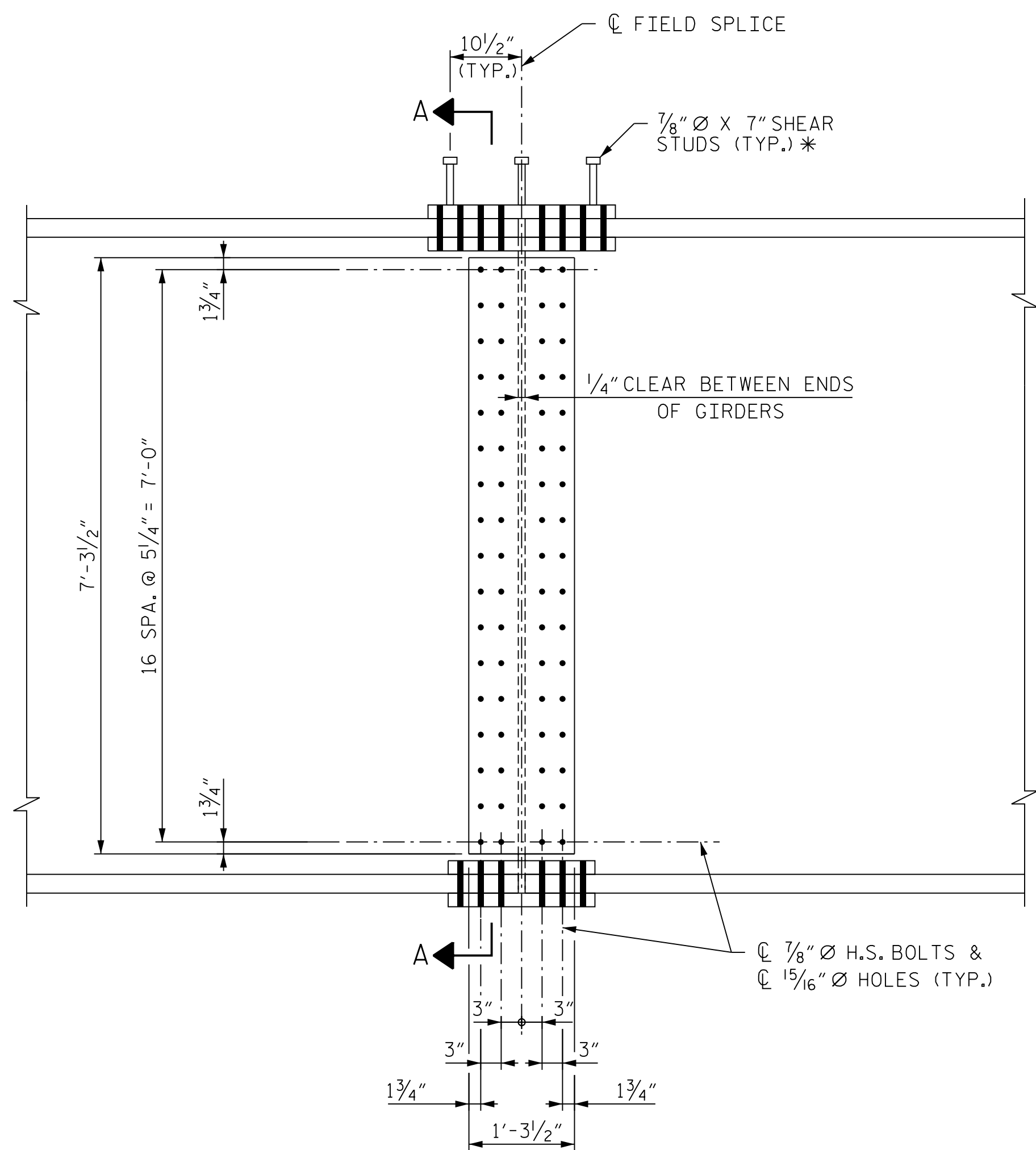

**ELEVATION**

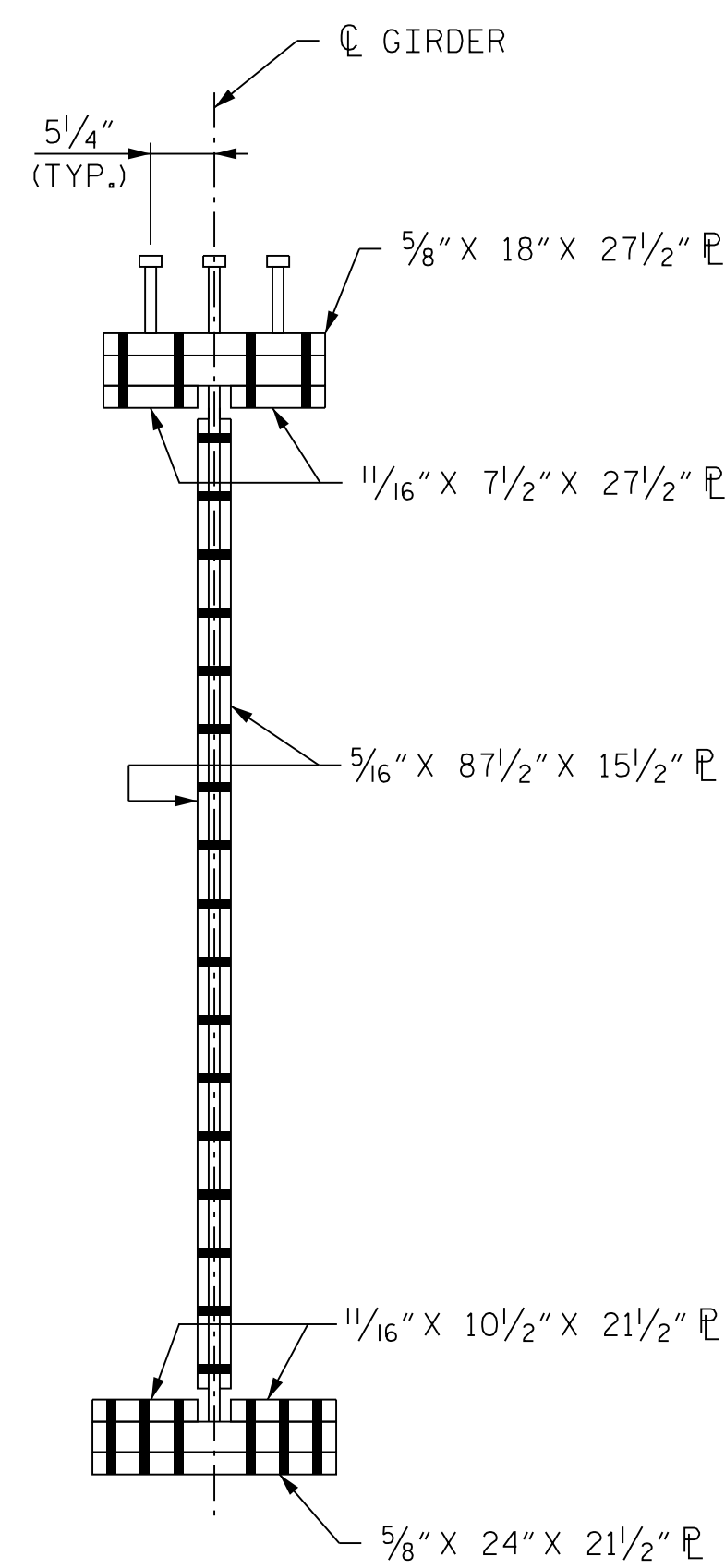

**SECTION A-A**

**NOTE**  
ORIENTATION OF PLAN AND ELEVATION VIEWS MAY VARY BASED ON FIELD SPLICE LOCATION

PROJECT NO. U-2579AB  
FORSYTH COUNTY  
STATION: 60+66.06 -Y15FLYAC-

SHEET 15 OF 19

STATE OF NORTH CAROLINA  
DEPARTMENT OF TRANSPORTATION  
RALEIGH

**SUPERSTRUCTURE  
BOLTED FIELD SPLICE  
DETAILS - TYPE "P"**



*Dominic A. Colletti* 10/15/2021

REVISIONS

NO.	BY:	DATE:	NO.	BY:	DATE:
1	--	--	3	--	--
2	--	--	4	--	--

SHEET NO.  
S04-055  
TOTAL SHEETS  
144



**DOCUMENT NOT CONSIDERED FINAL  
UNLESS ALL SIGNATURES COMPLETED**

PLOT DRIVER: NCDOT... PENTABLE: NCDOT STRUCTURES DEFAULT PEN.tbl  
 USER: PPETERSO DATE: 10/14/2021 TIME: 4:01:59 PM  
 FILE: ... \ASUPERS

DES BY: <u>T. ANDREWS</u>	DATE: <u>07/19</u>	DWG BY: <u>B. PETERSON</u>	DATE: <u>07/19</u>
DES CHK: <u>D. OLDS</u>	DATE: <u>08/19</u>	CHK BY: <u>T. ANDREWS</u>	DATE: <u>10/19</u>

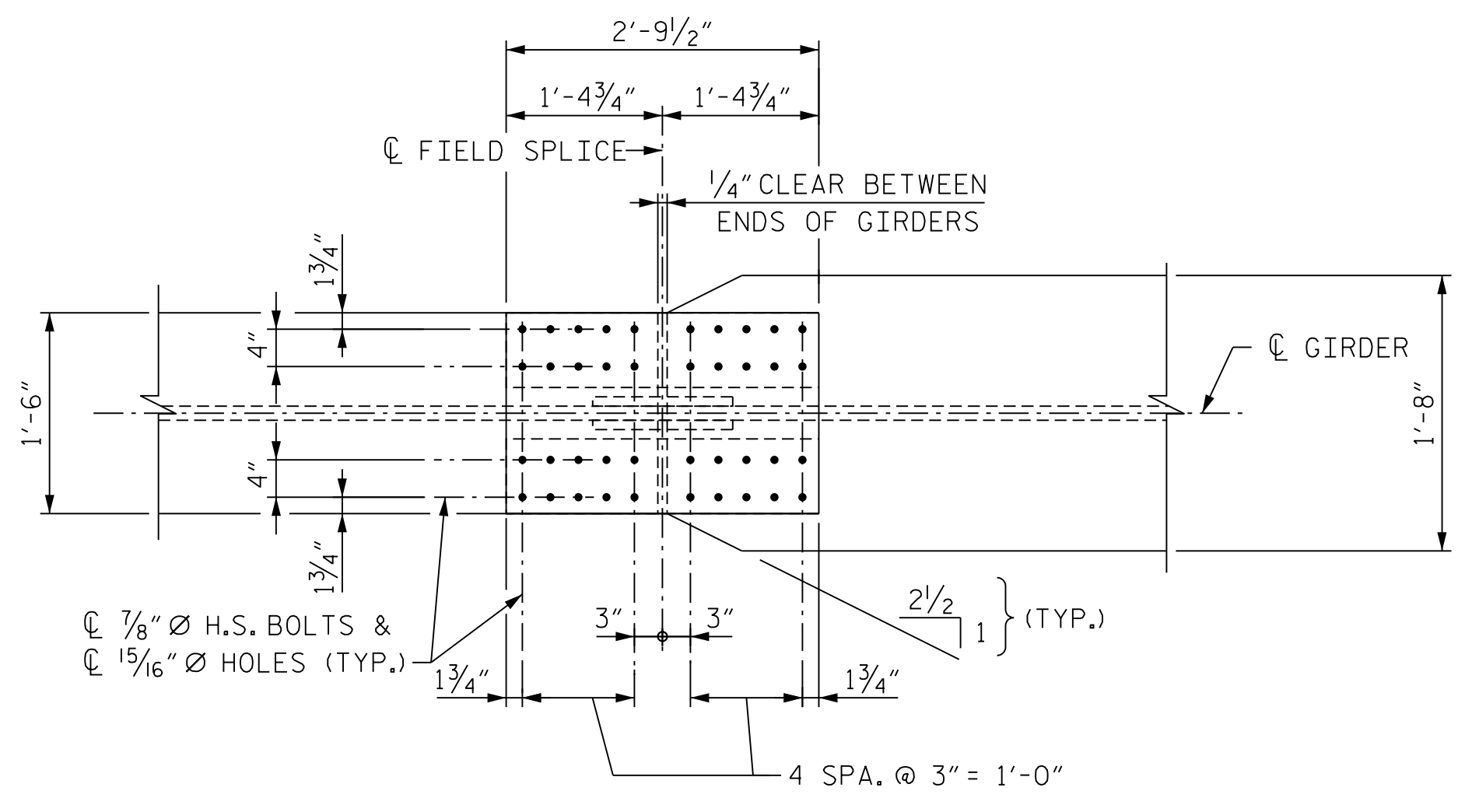

**PLAN (TOP OF TOP FLANGE)**  
(STUDS NOT SHOWN FOR CLARITY)

\* = SHEAR STUDS ARE TO BE SHOP WELDED ON TOP OF PLATE BEFORE FIELD ASSEMBLY

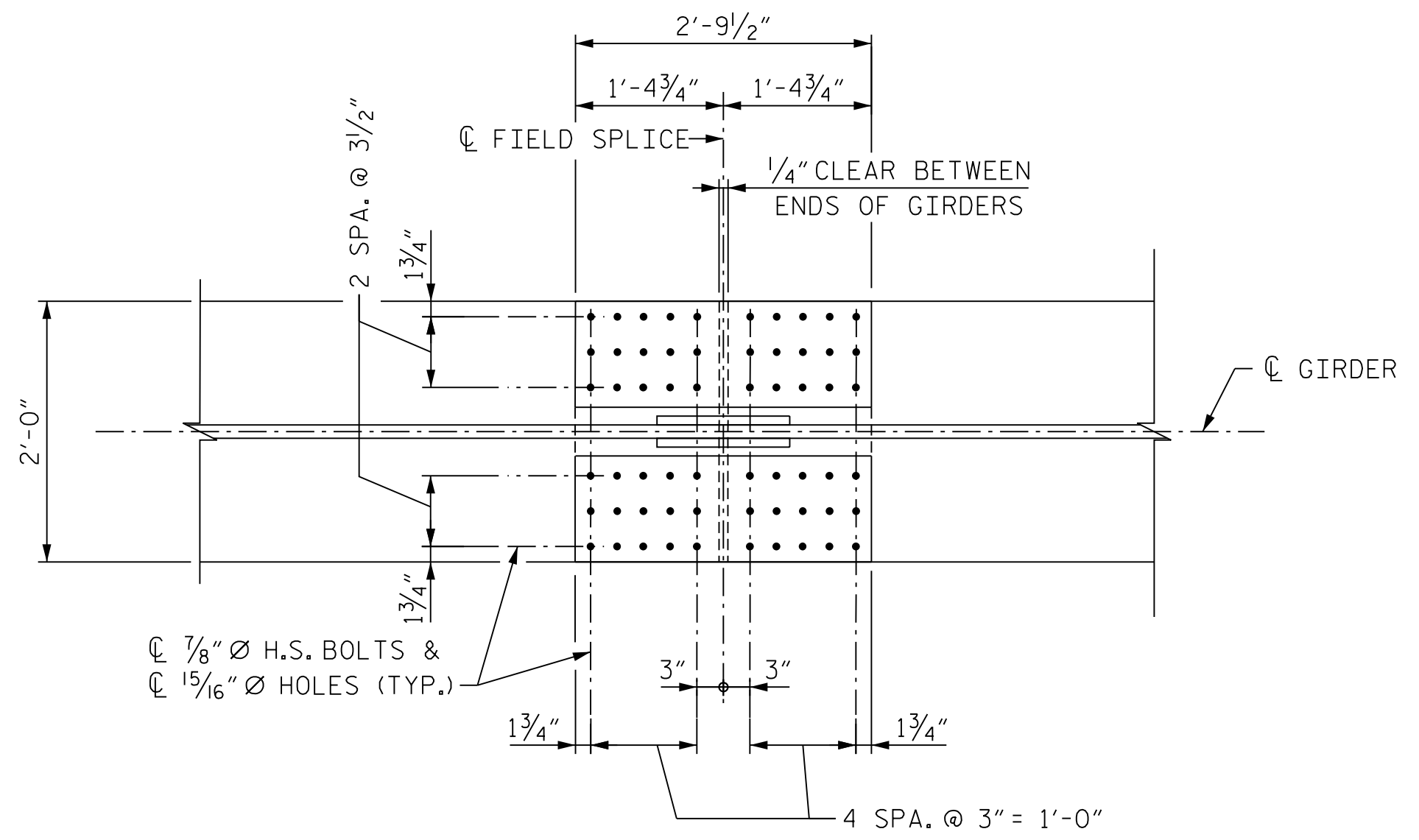

**PLAN (TOP OF BOTTOM FLANGE)**

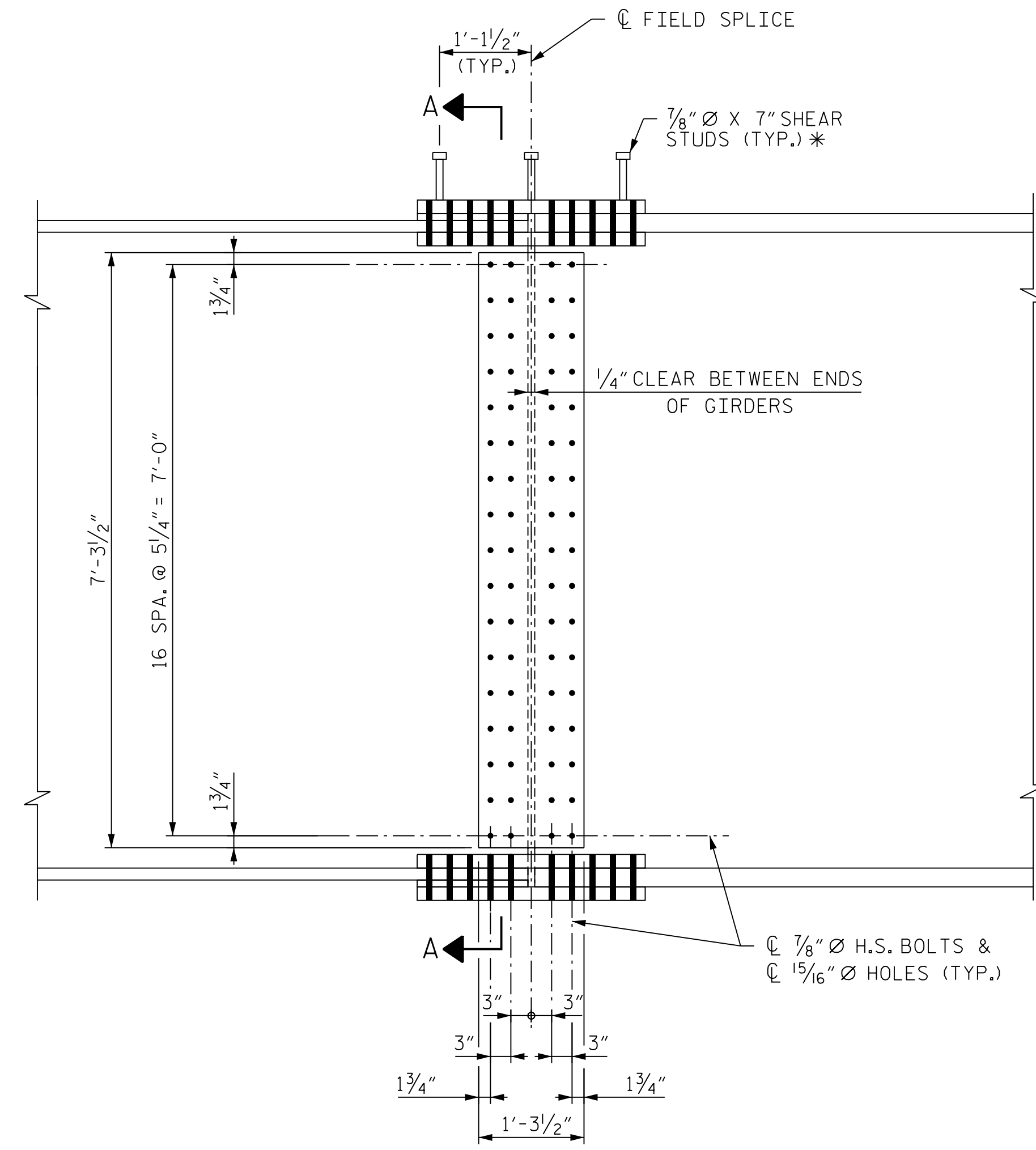

**ELEVATION**

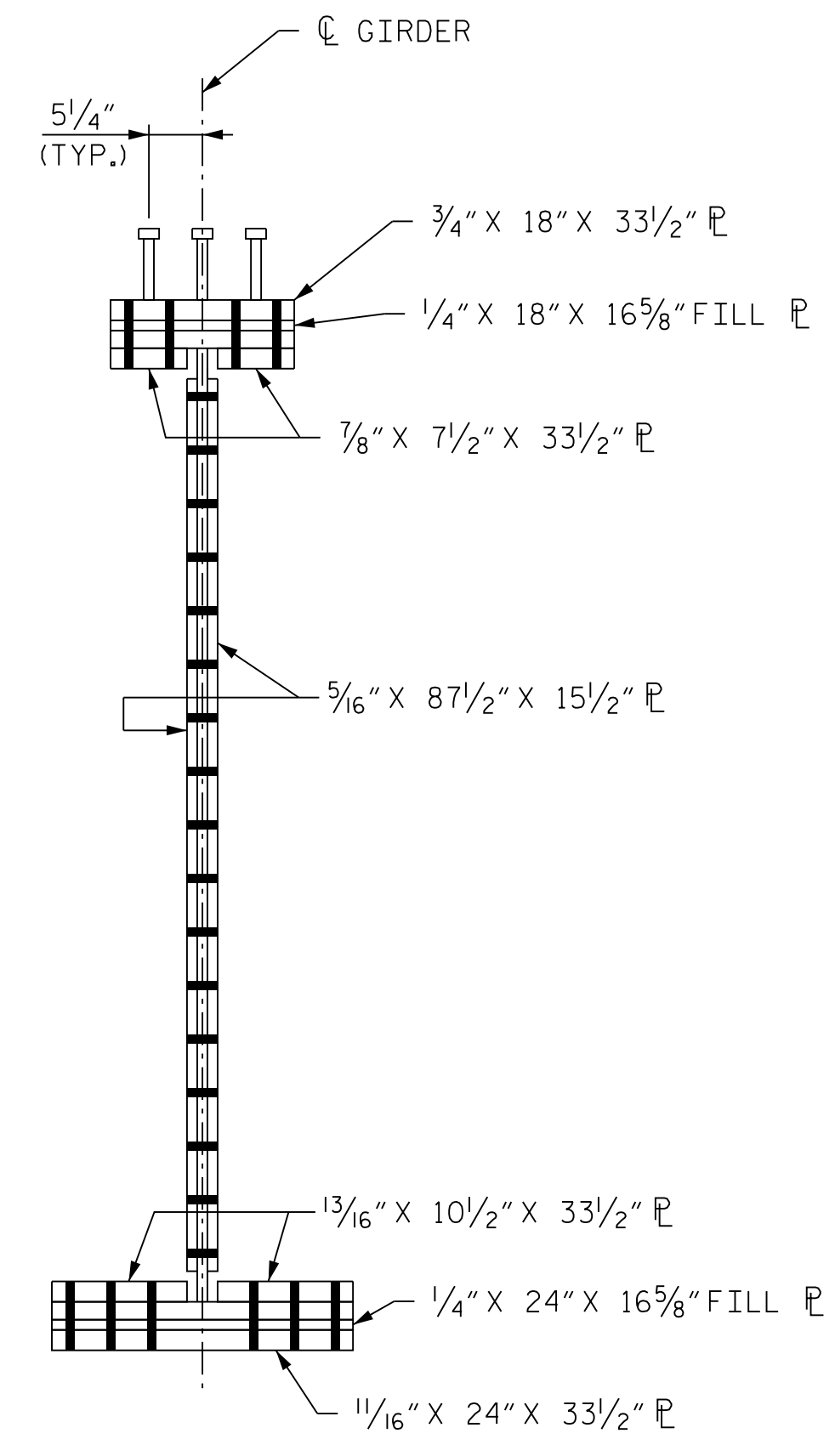

**SECTION A-A**

**NOTE**  
ORIENTATION OF PLAN AND ELEVATION VIEWS MAY VARY BASED ON FIELD SPLICE LOCATION

PROJECT NO. U-2579AB  
FORSYTH COUNTY  
 STATION: 60+66.06 -Y15FLYAC-  
 SHEET 16 OF 19

STATE OF NORTH CAROLINA  
 DEPARTMENT OF TRANSPORTATION  
 RALEIGH

**SUPERSTRUCTURE  
 BOLTED FIELD SPLICE  
 DETAILS - TYPE "Q"**

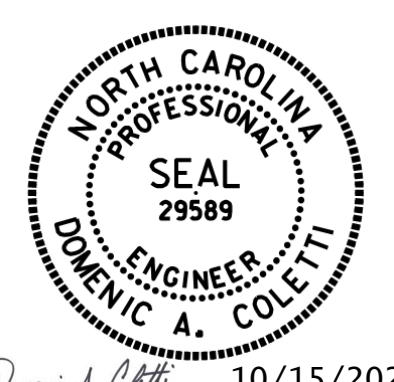

10/15/2021

REVISIONS						SHEET NO. S04-056 TOTAL SHEETS 144
NO.	BY:	DATE:	NO.	BY:	DATE:	
1	--	--	3	--	--	
2	--	--	4	--	--	

**HDR** HDR Engineering, Inc. of the Carolinas  
 555 Fayetteville St., Suite 900 Raleigh, N.C. 27601  
 N.C.B.E.L.S. License Number: F-0116

**DOCUMENT NOT CONSIDERED FINAL  
 UNLESS ALL SIGNATURES COMPLETED**

PLOT DRIVER: NCDOT\_pdf\_color\_eng-50dpi  
 USER: PPETERSO DATE: 10/14/2021  
 PENTABLE: NCDOT\_STRUCTURES\_DEFAULT\_PEN.tbl  
 TIME: 4:02:00 PM  
 FILE: ... \SUPERS

DES BY: <u>T. ANDREWS</u>	DATE: <u>07/19</u>	DWG BY: <u>B. PETERSON</u>	DATE: <u>07/19</u>
DES CHK: <u>D. OLDS</u>	DATE: <u>08/19</u>	CHK BY: <u>T. ANDREWS</u>	DATE: <u>10/19</u>

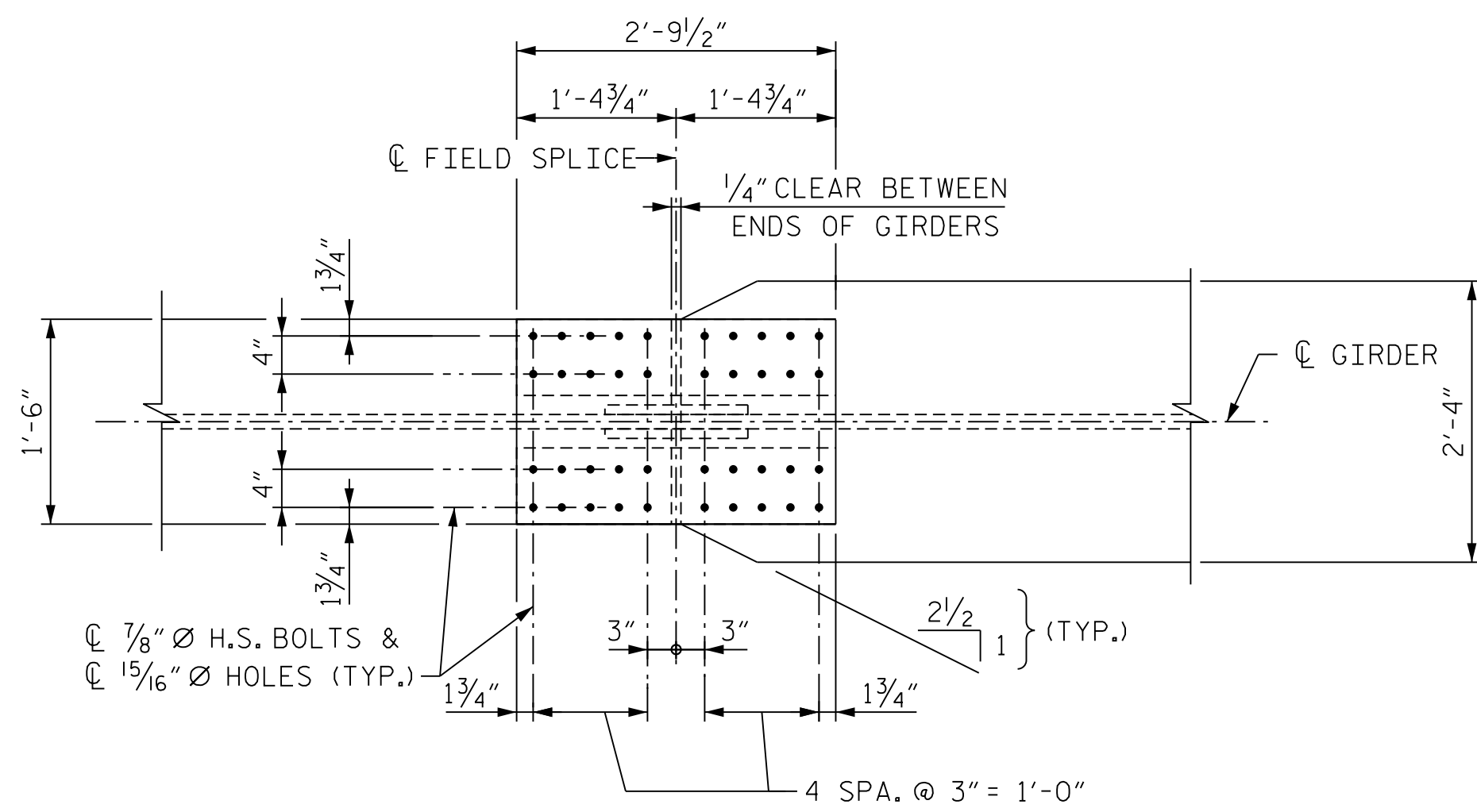

**PLAN (TOP OF TOP FLANGE)**

(STUDS NOT SHOWN FOR CLARITY)

\* = SHEAR STUDS ARE TO BE SHOP WELDED ON TOP OF PLATE BEFORE FIELD ASSEMBLY

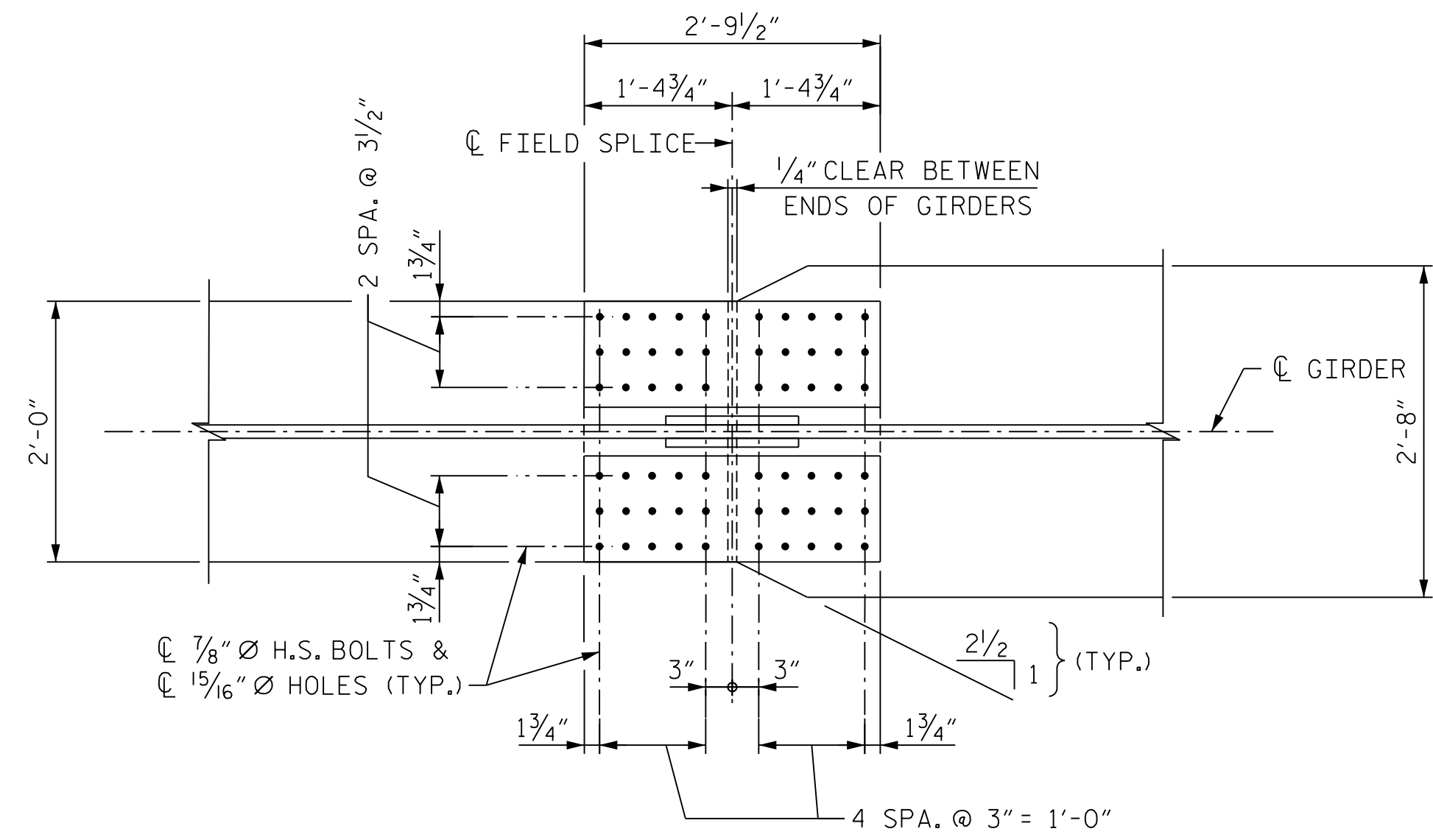

**PLAN (TOP OF BOTTOM FLANGE)**

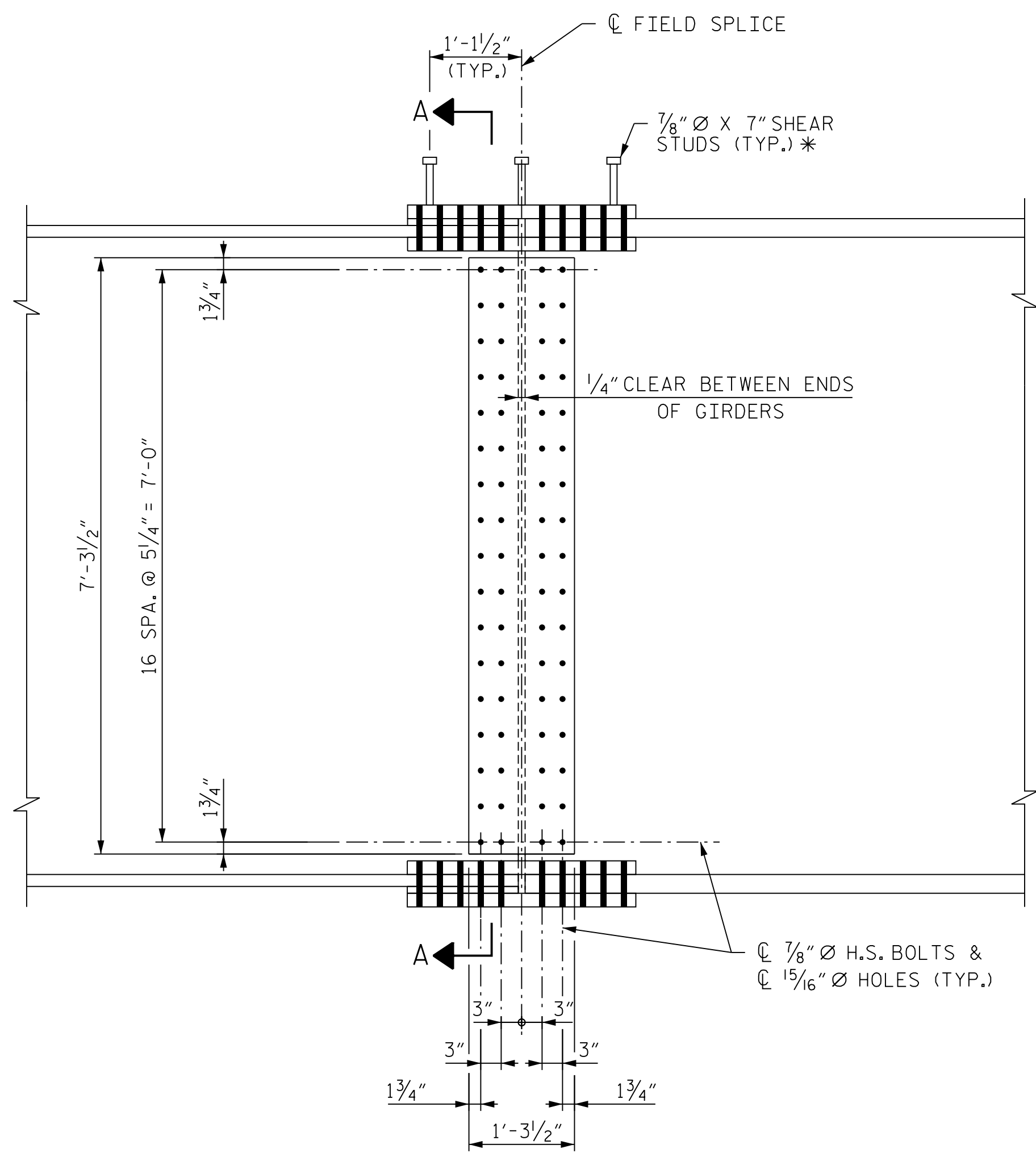

**ELEVATION**

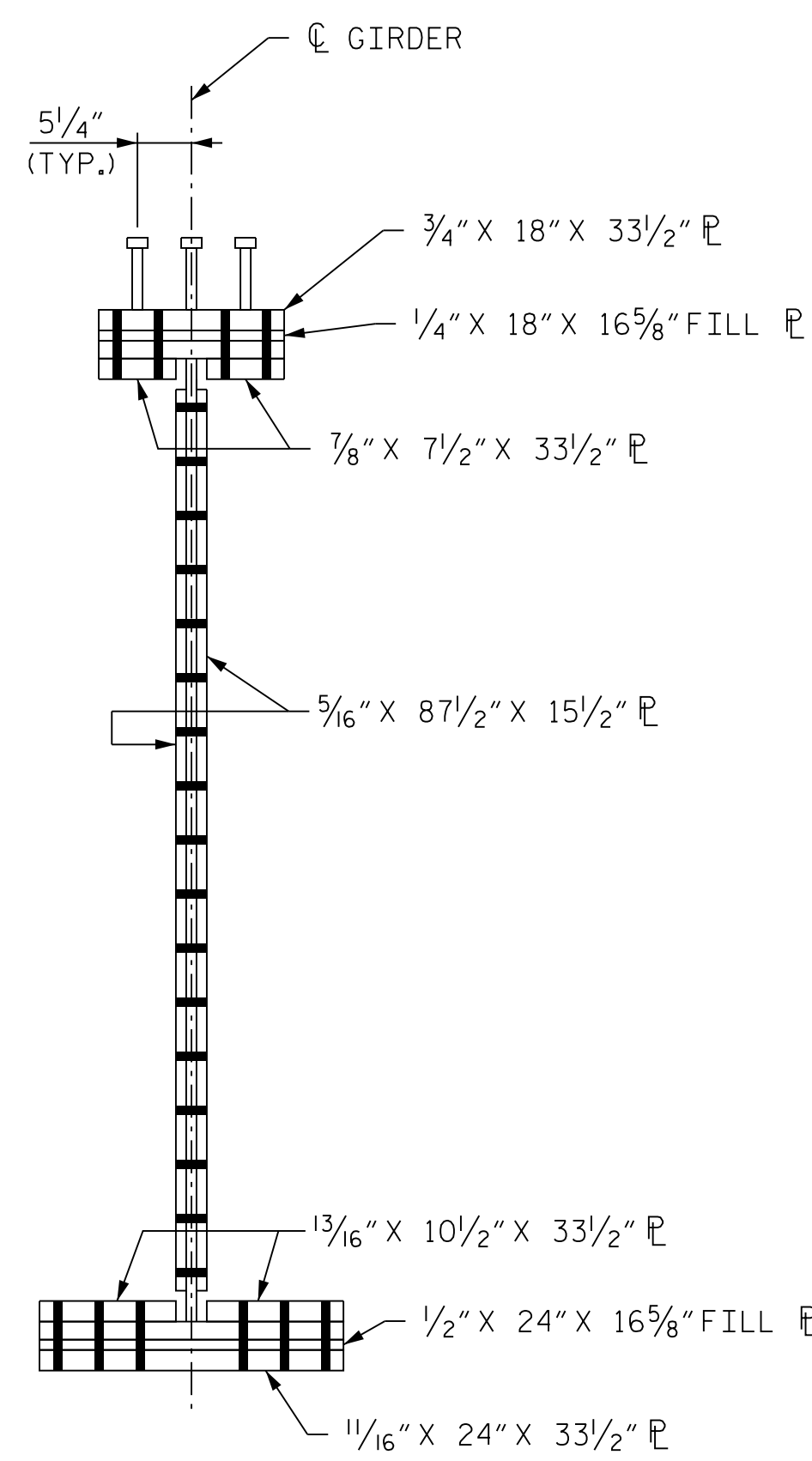

**SECTION A-A**

**NOTE**  
ORIENTATION OF PLAN AND ELEVATION VIEWS MAY VARY BASED ON FIELD SPLICE LOCATION

PROJECT NO. U-2579AB  
FORSYTH COUNTY  
STATION: 60+66.06 -Y15FLYAC-  
SHEET 17 OF 19

STATE OF NORTH CAROLINA  
DEPARTMENT OF TRANSPORTATION  
RALEIGH

**SUPERSTRUCTURE  
BOLTED FIELD SPLICE  
DETAILS - TYPE "R"**

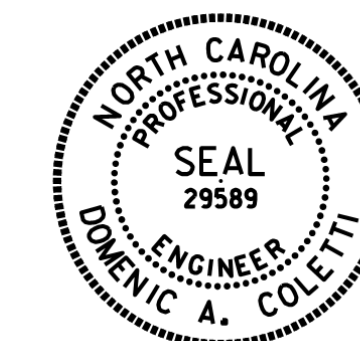

*Domenic A. Colletti* 10/15/2021

REVISIONS						SHEET NO. S04-057 TOTAL SHEETS 144
NO.	BY:	DATE:	NO.	BY:	DATE:	
1	--	--	3	--	--	
2	--	--	4	--	--	



**DOCUMENT NOT CONSIDERED FINAL  
UNLESS ALL SIGNATURES COMPLETED**

PLOT DRIVER: NCDOT... PENTABLE: NCDOT... USER: PPETERSO... FILE: ...

DES BY: <u>T. ANDREWS</u>	DATE : <u>07/19</u>	DWG BY: <u>B. PETERSON</u>	DATE : <u>07/19</u>
DES CHK: <u>D. OLDS</u>	DATE : <u>08/19</u>	CHK BY: <u>T. ANDREWS</u>	DATE : <u>10/19</u>

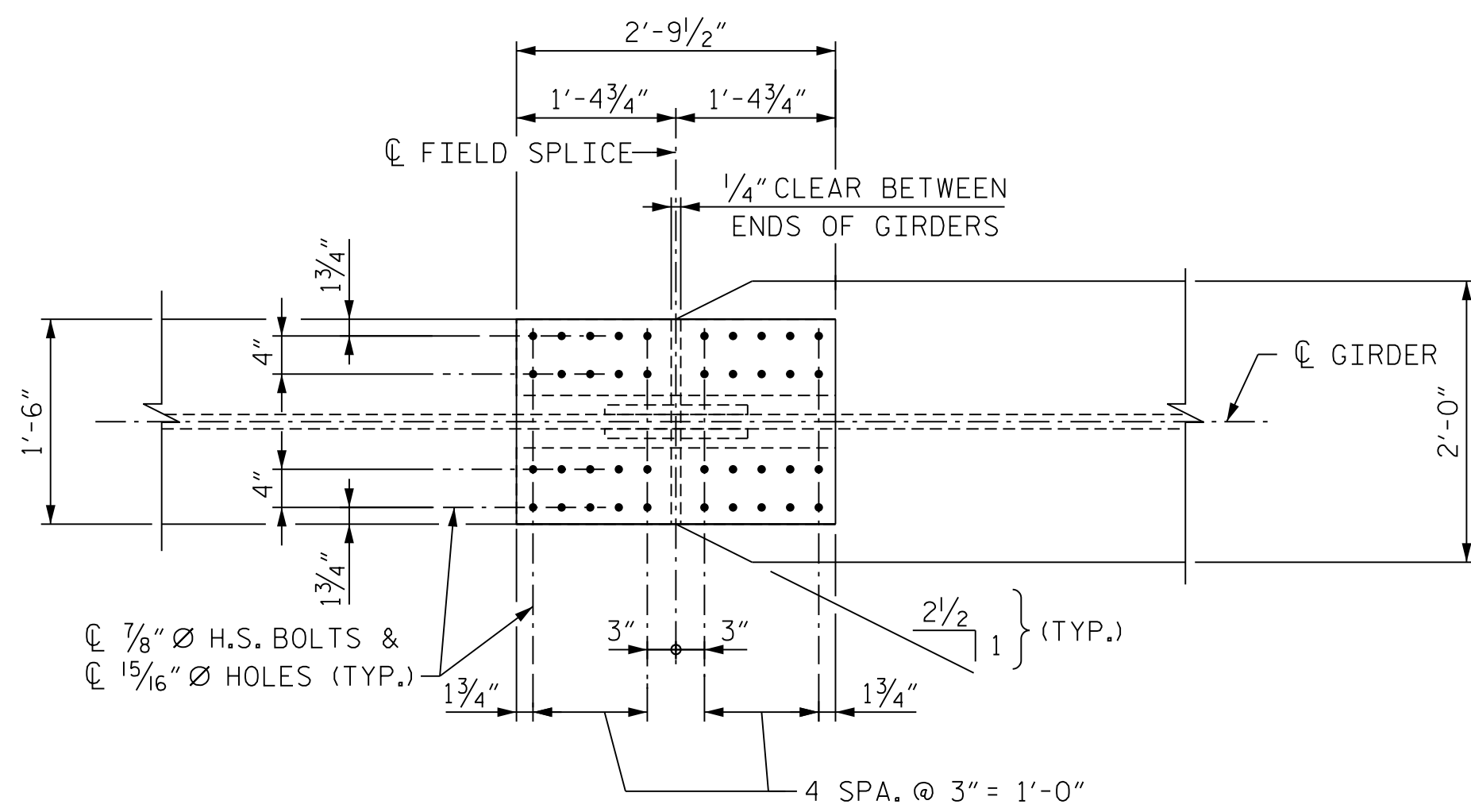

**PLAN (TOP OF TOP FLANGE)**

(STUDS NOT SHOWN FOR CLARITY)

\* = SHEAR STUDS ARE TO BE SHOP WELDED ON TOP OF PLATE BEFORE FIELD ASSEMBLY

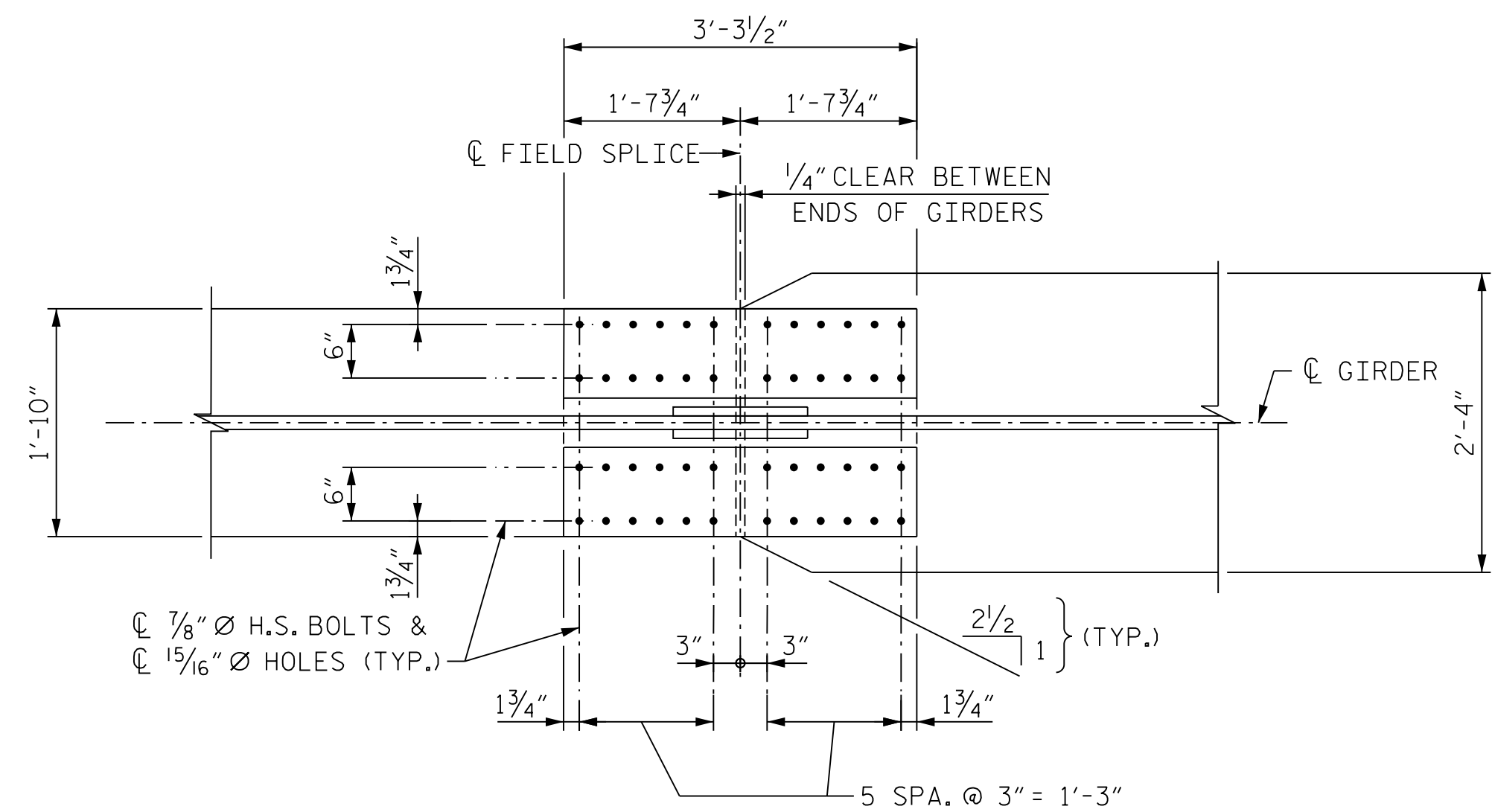

**PLAN (TOP OF BOTTOM FLANGE)**

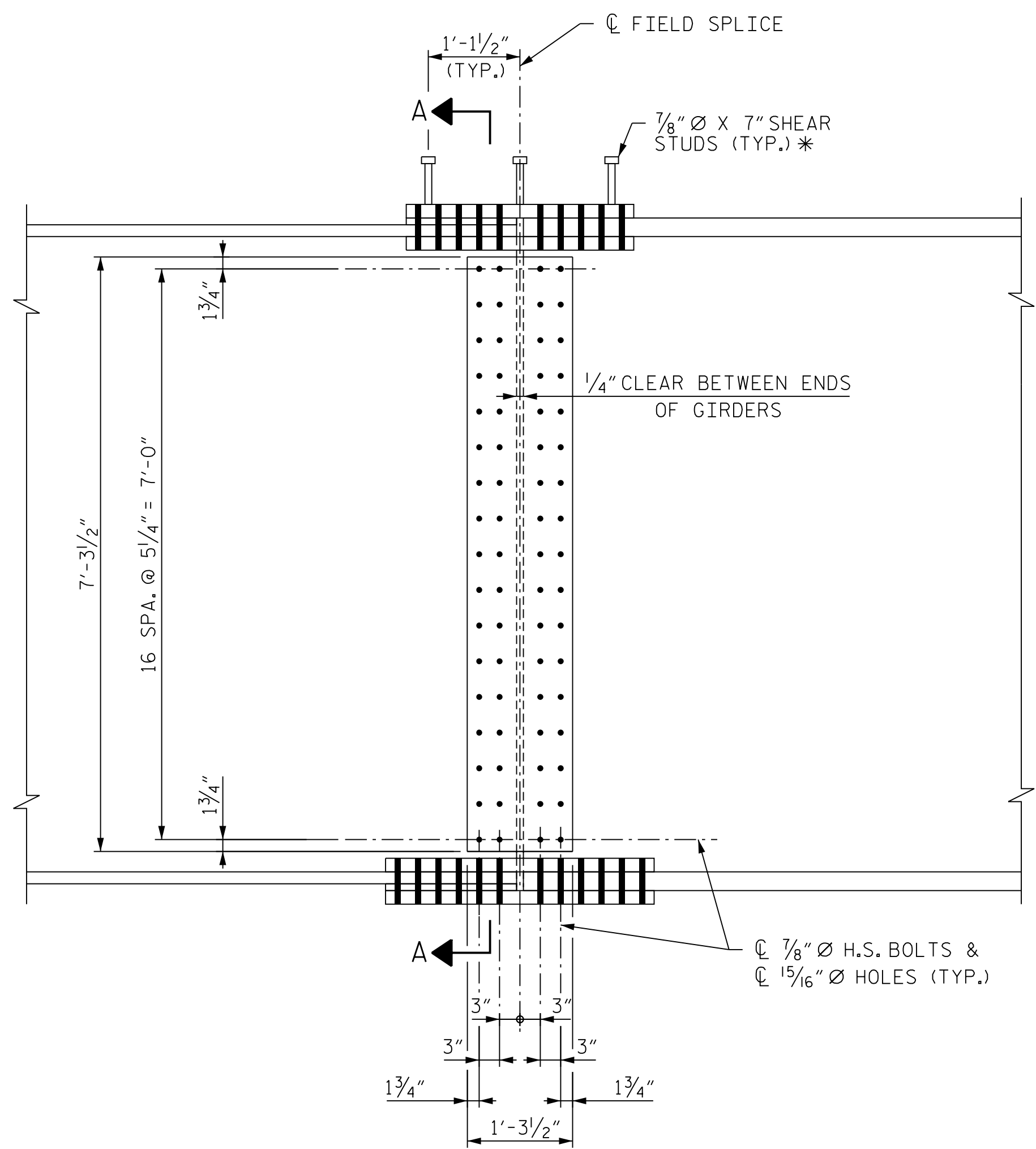

**ELEVATION**

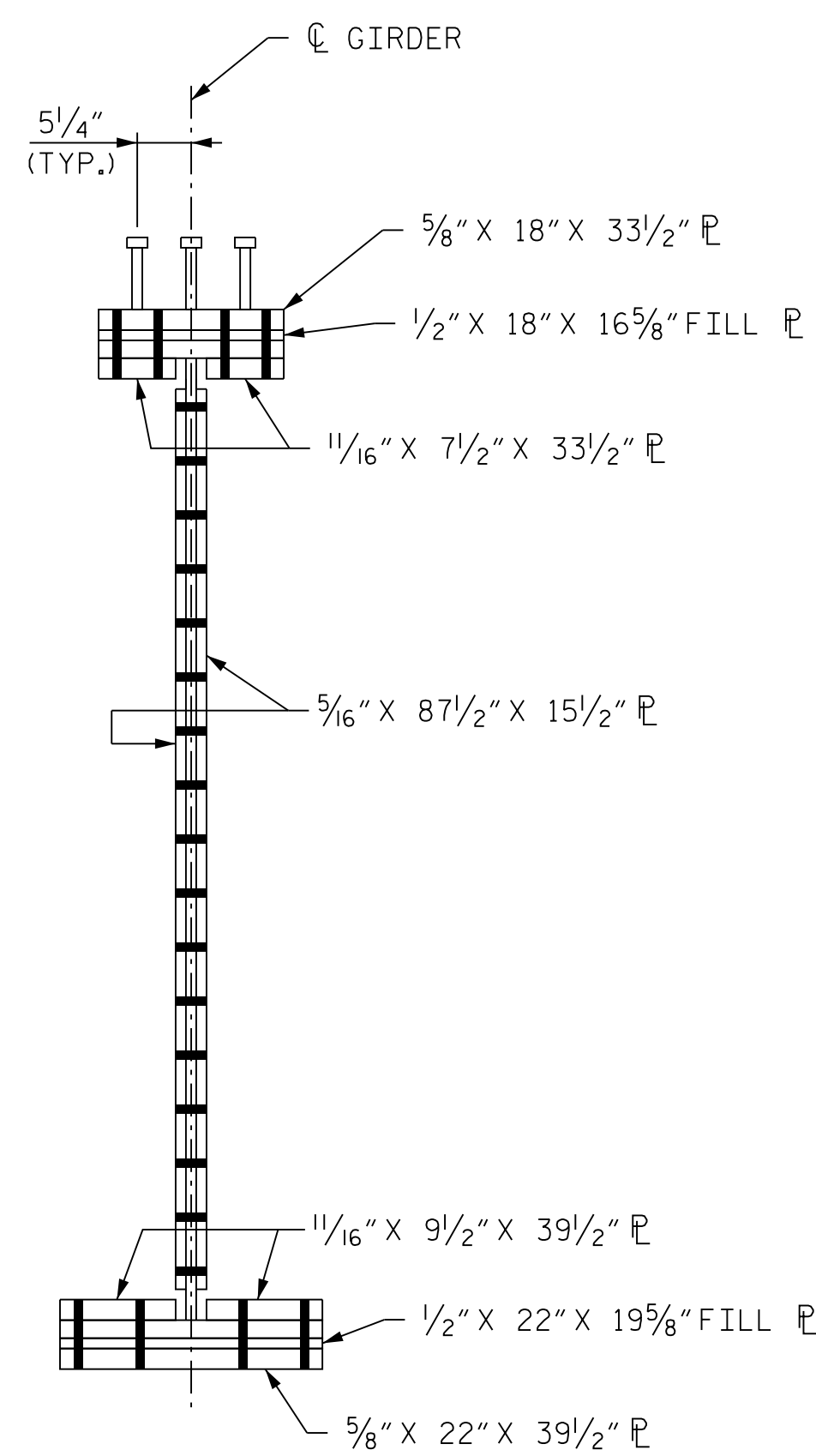

**SECTION A-A**

**NOTE**  
ORIENTATION OF PLAN AND ELEVATION VIEWS MAY VARY BASED ON FIELD SPLICE LOCATION

PROJECT NO. U-2579AB  
FORSYTH COUNTY  
STATION: 60+66.06 -Y15FLYAC-

SHEET 18 OF 19

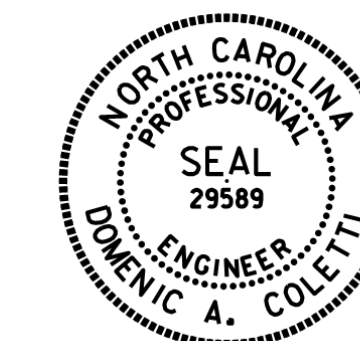

*Domini A. Colletti* 10/15/2021

STATE OF NORTH CAROLINA  
DEPARTMENT OF TRANSPORTATION  
RALEIGH

**SUPERSTRUCTURE  
BOLTED FIELD SPLICE  
DETAILS - TYPE "S"**

REVISIONS						SHEET NO. S04-058 TOTAL SHEETS 144
NO.	BY:	DATE:	NO.	BY:	DATE:	
1	--	--	3	--	--	
2	--	--	4	--	--	

**HDR** HDR Engineering, Inc. of the Carolinas  
555 Fayetteville St., Suite 900 Raleigh, N.C. 27601  
N.C.B.E.L.S. License Number: F-0116

**DOCUMENT NOT CONSIDERED FINAL  
UNLESS ALL SIGNATURES COMPLETED**

PLOT DRIVER: NCDOT\_pdf\_color\_eng-50.ppt  
USER: PPETERSO DATE: 10/14/2021  
PENTABLE: NCDOT\_STRUCTURES\_DEFAULT\_PEN.tbl  
TIME: 4:02:03 PM  
FILE: ... \SUPERS

DES BY: <u>T. ANDREWS</u>	DATE: <u>07/19</u>	DWG BY: <u>B. PETERSON</u>	DATE: <u>07/19</u>
DES CHK: <u>D. OLDS</u>	DATE: <u>08/19</u>	CHK BY: <u>T. ANDREWS</u>	DATE: <u>10/19</u>

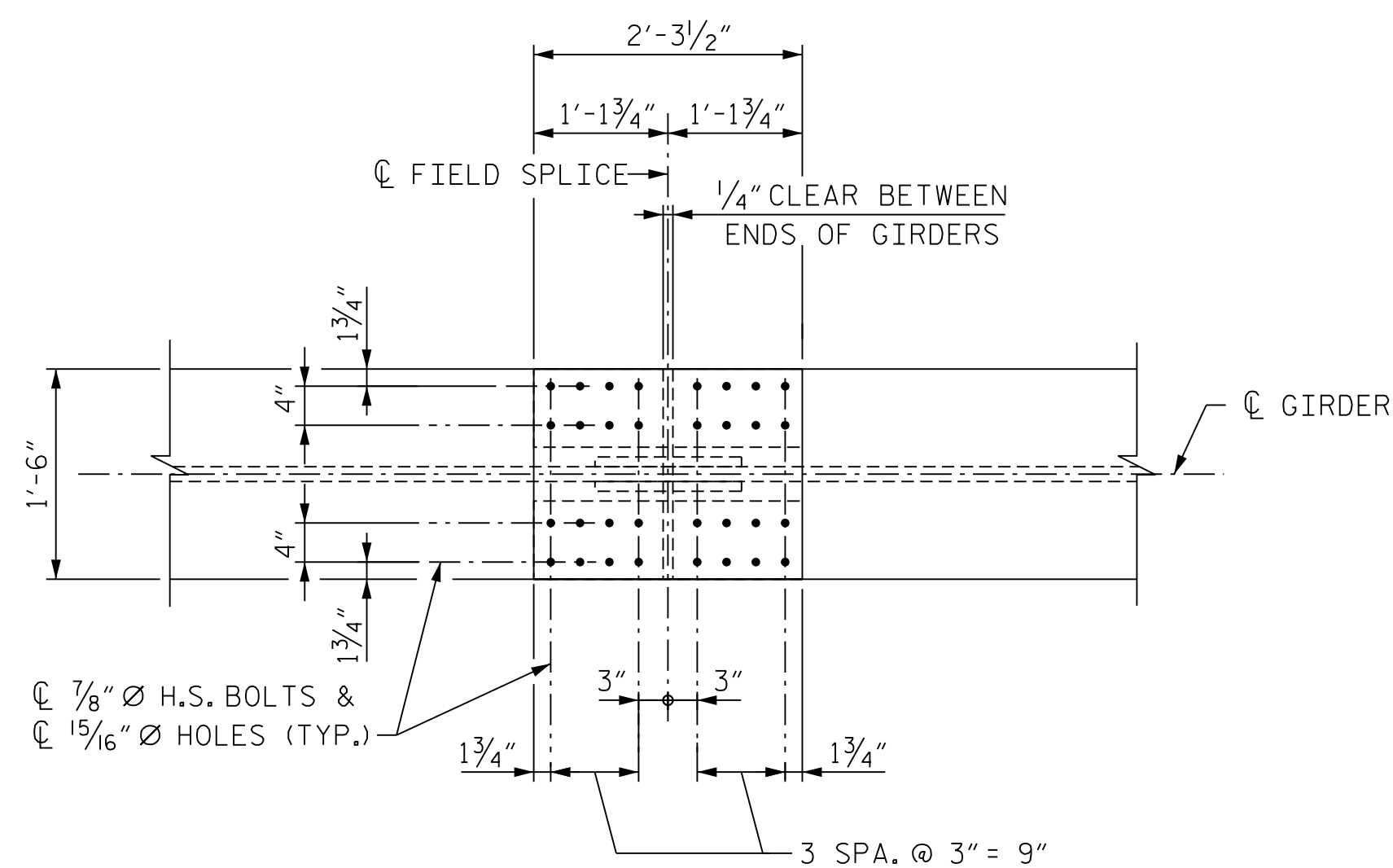

**PLAN (TOP OF TOP FLANGE)**  
(STUDS NOT SHOWN FOR CLARITY)

\* = SHEAR STUDS ARE TO BE SHOP WELDED ON TOP OF PLATE BEFORE FIELD ASSEMBLY

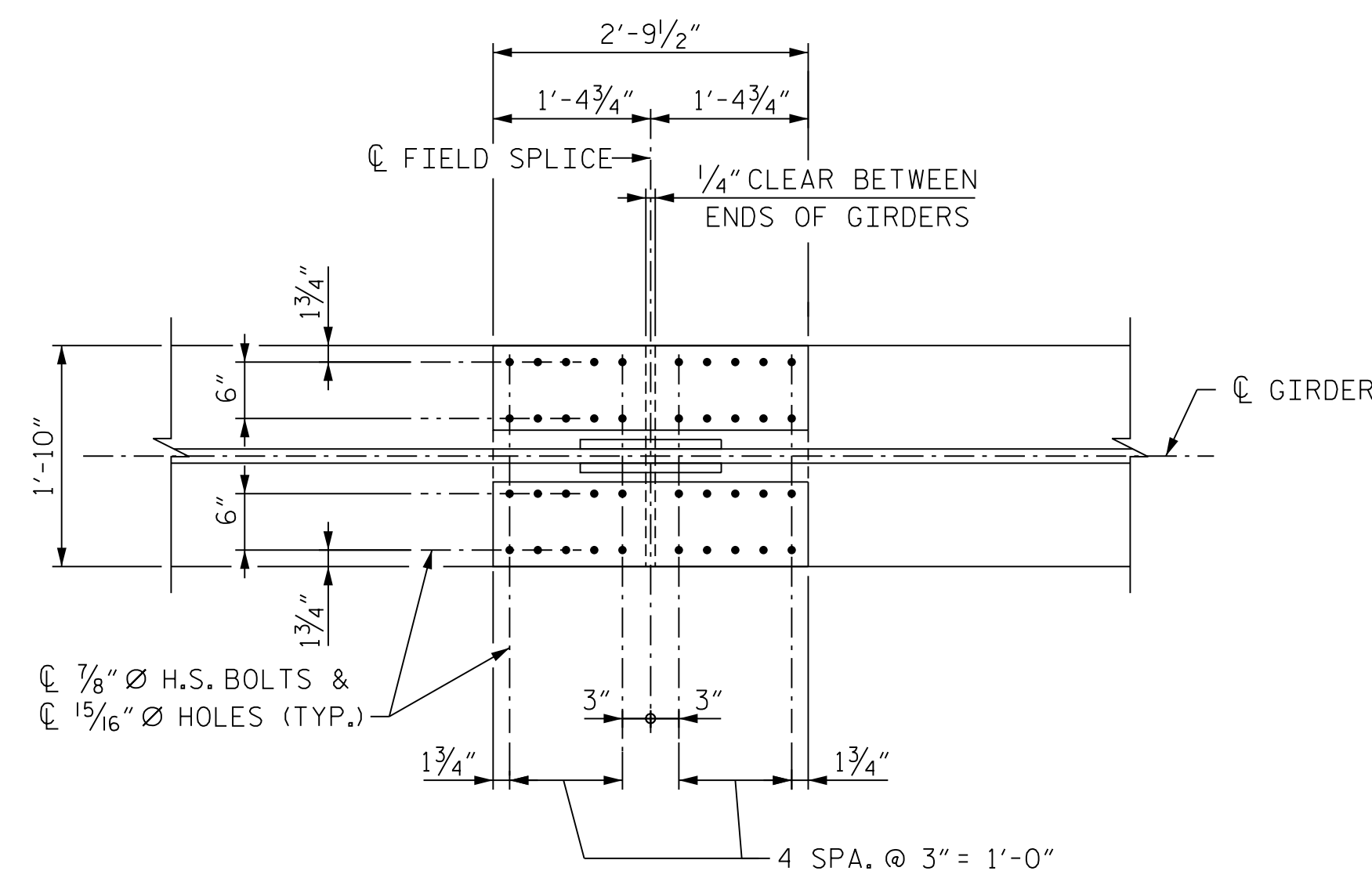

**PLAN (TOP OF BOTTOM FLANGE)**

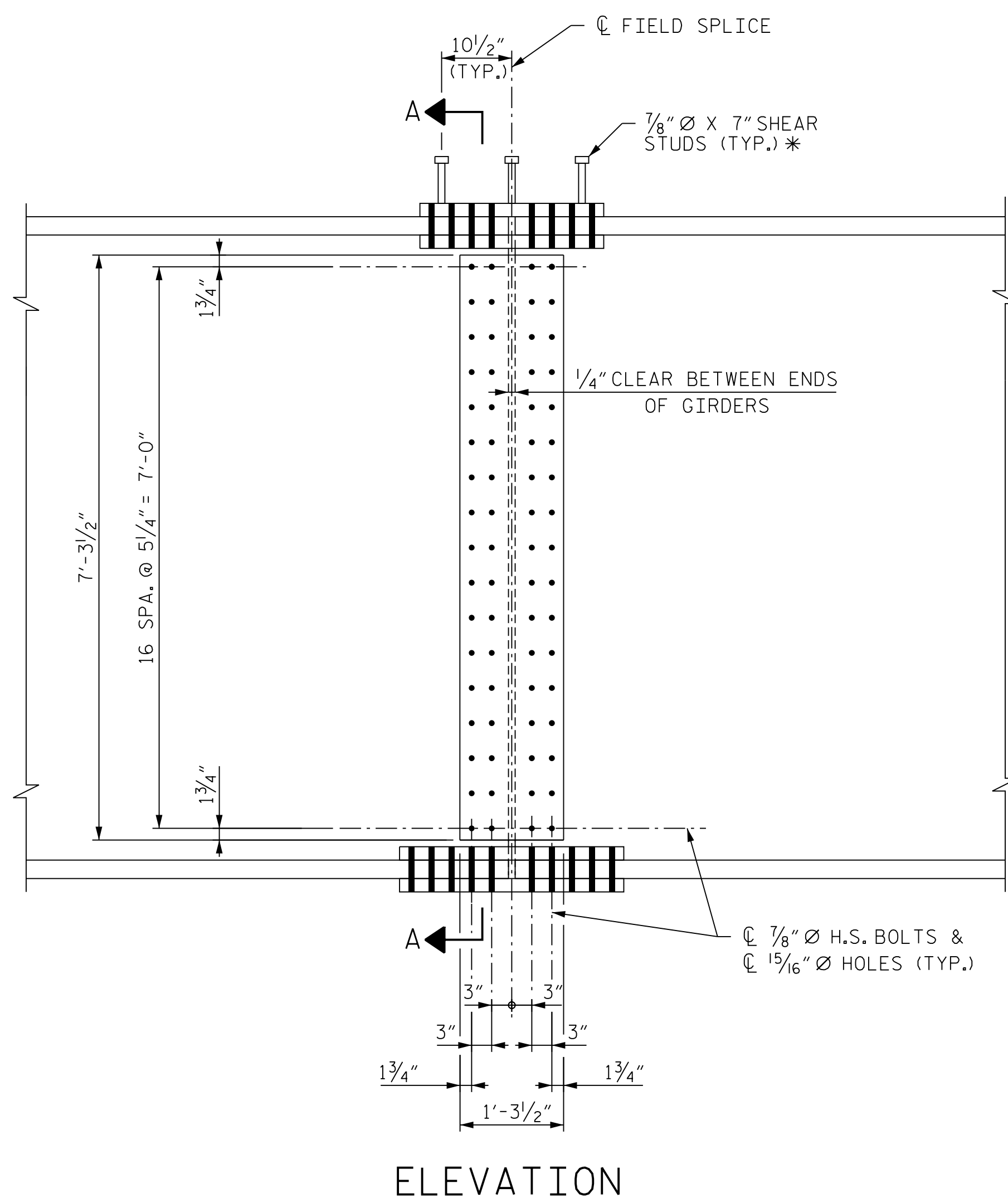

**ELEVATION**

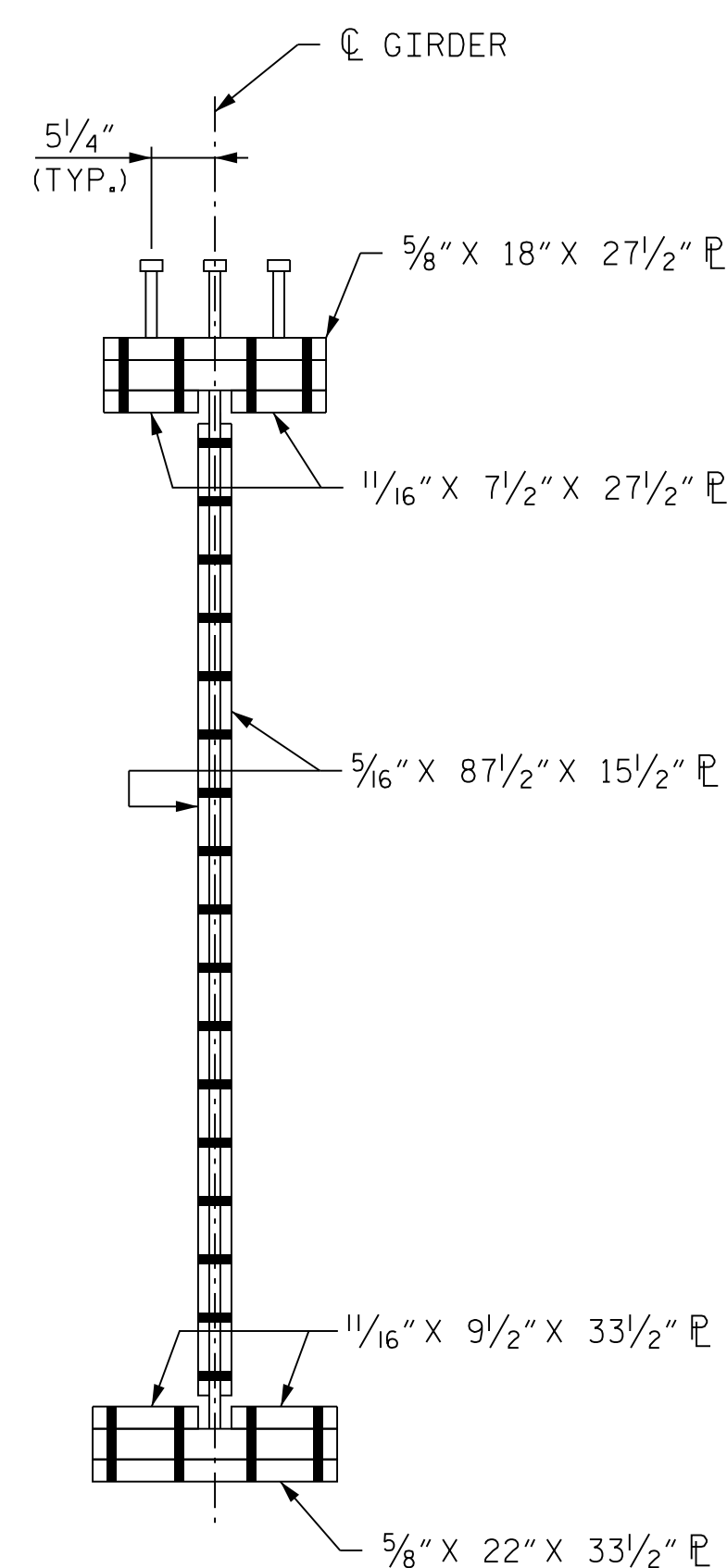

**SECTION A-A**

**NOTE**  
ORIENTATION OF PLAN AND ELEVATION VIEWS MAY VARY BASED ON FIELD SPLICE LOCATION

PROJECT NO. U-2579AB  
FORSYTH COUNTY  
STATION: 60+66.06 -Y15FLYAC-

SHEET 19 OF 19

STATE OF NORTH CAROLINA  
DEPARTMENT OF TRANSPORTATION  
RALEIGH

**SUPERSTRUCTURE  
BOLTED FIELD SPLICE  
DETAILS - TYPE "T"**



*Dominic A. Colletti* 10/15/2021

REVISIONS

NO.	BY:	DATE:	NO.	BY:	DATE:
1	--	--	3	--	--
2	--	--	4	--	--

SHEET NO.  
S04-059  
TOTAL SHEETS  
144



**DOCUMENT NOT CONSIDERED FINAL  
UNLESS ALL SIGNATURES COMPLETED**

PLOT DRIVER: NCDOT\_pdf\_color\_eng-50.ppt  
 USER: PPETERSO DATE: 10/14/2021  
 FILE: ... \SUPERS

DES BY: T. ANDREWS DATE: 07/19 DWG BY: B. PETERSON DATE: 07/19  
 DES CHK: D. OLDS DATE: 08/19 CHK BY: T. ANDREWS DATE: 10/19

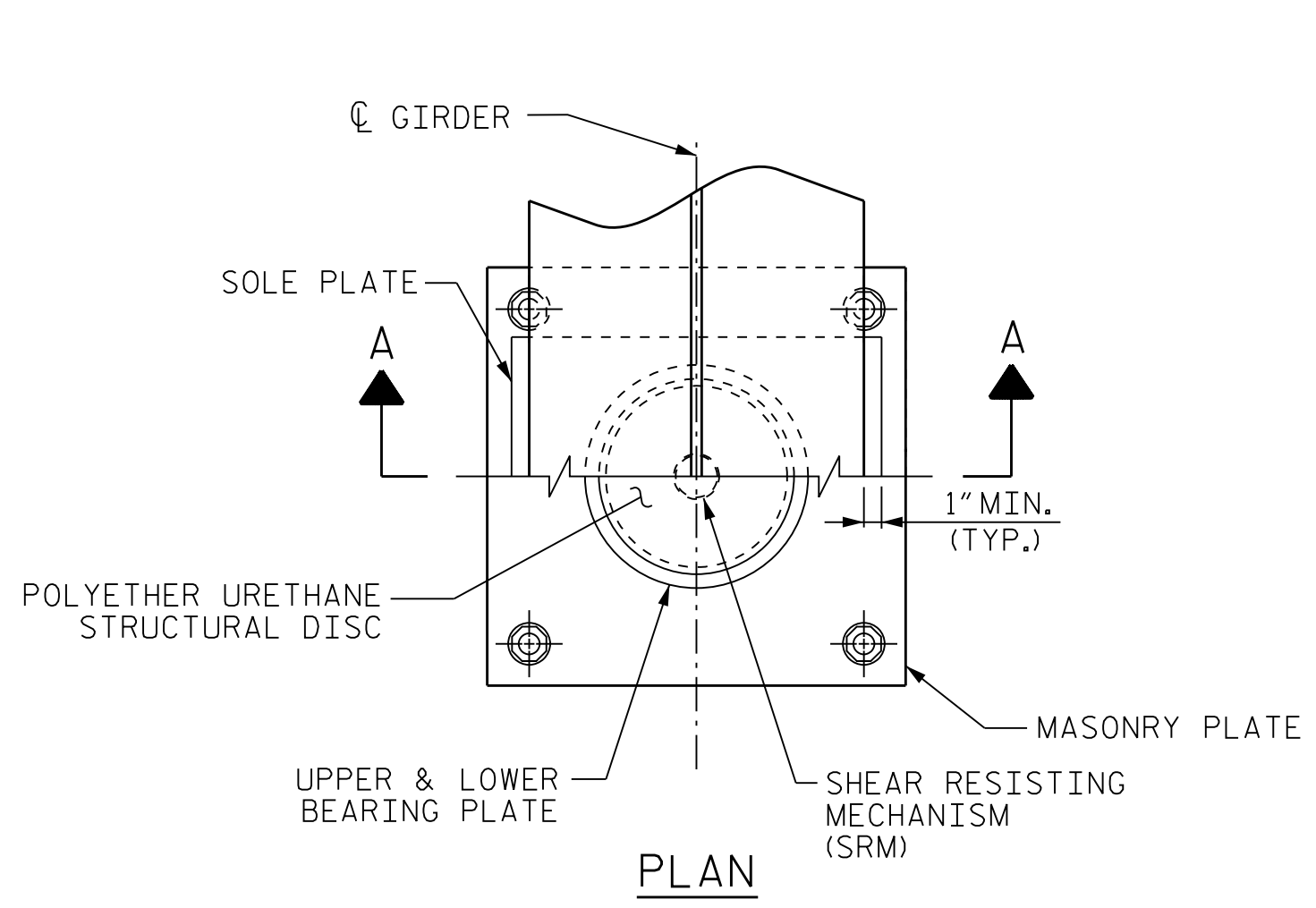

PLAN

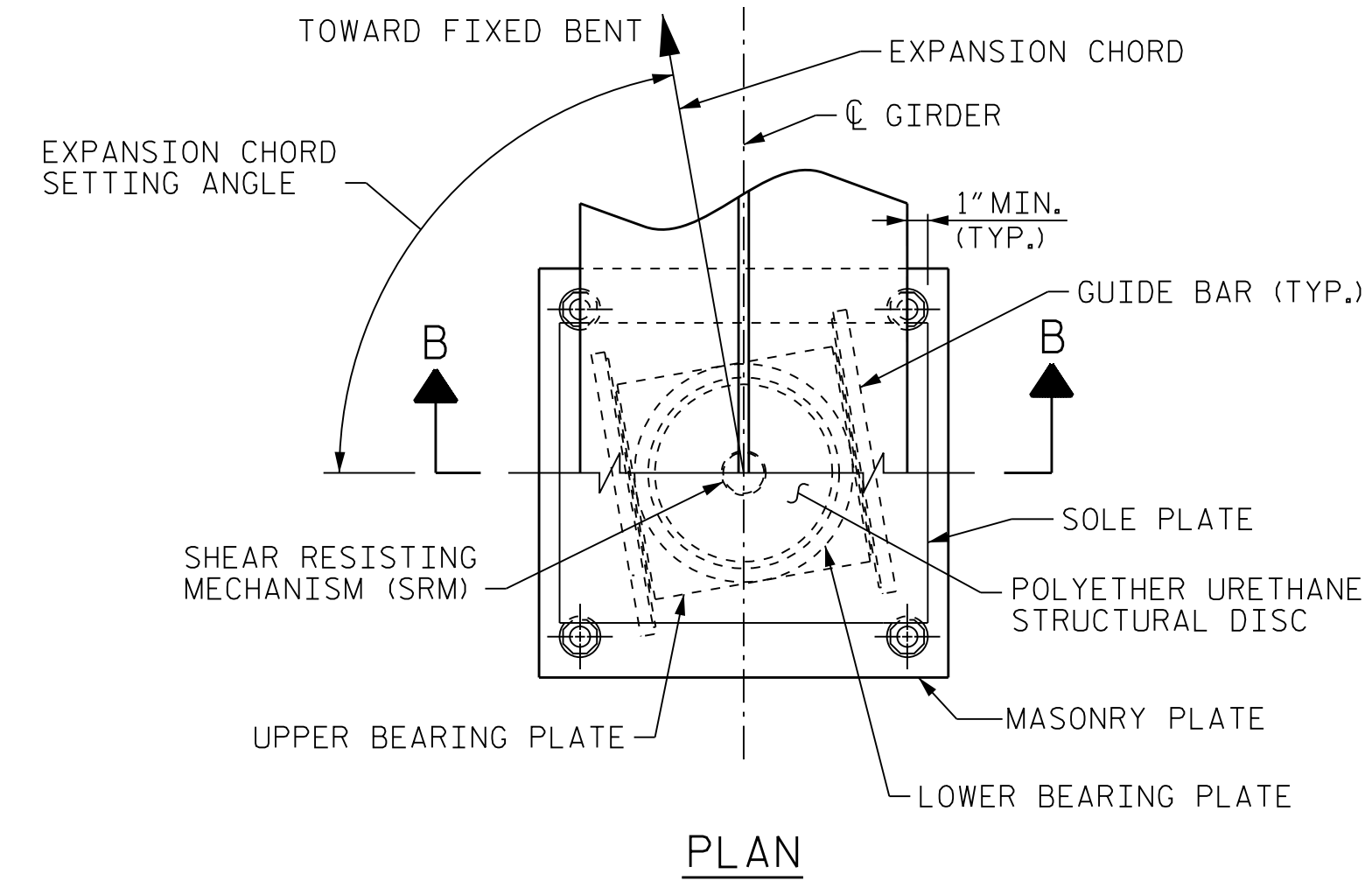

PLAN

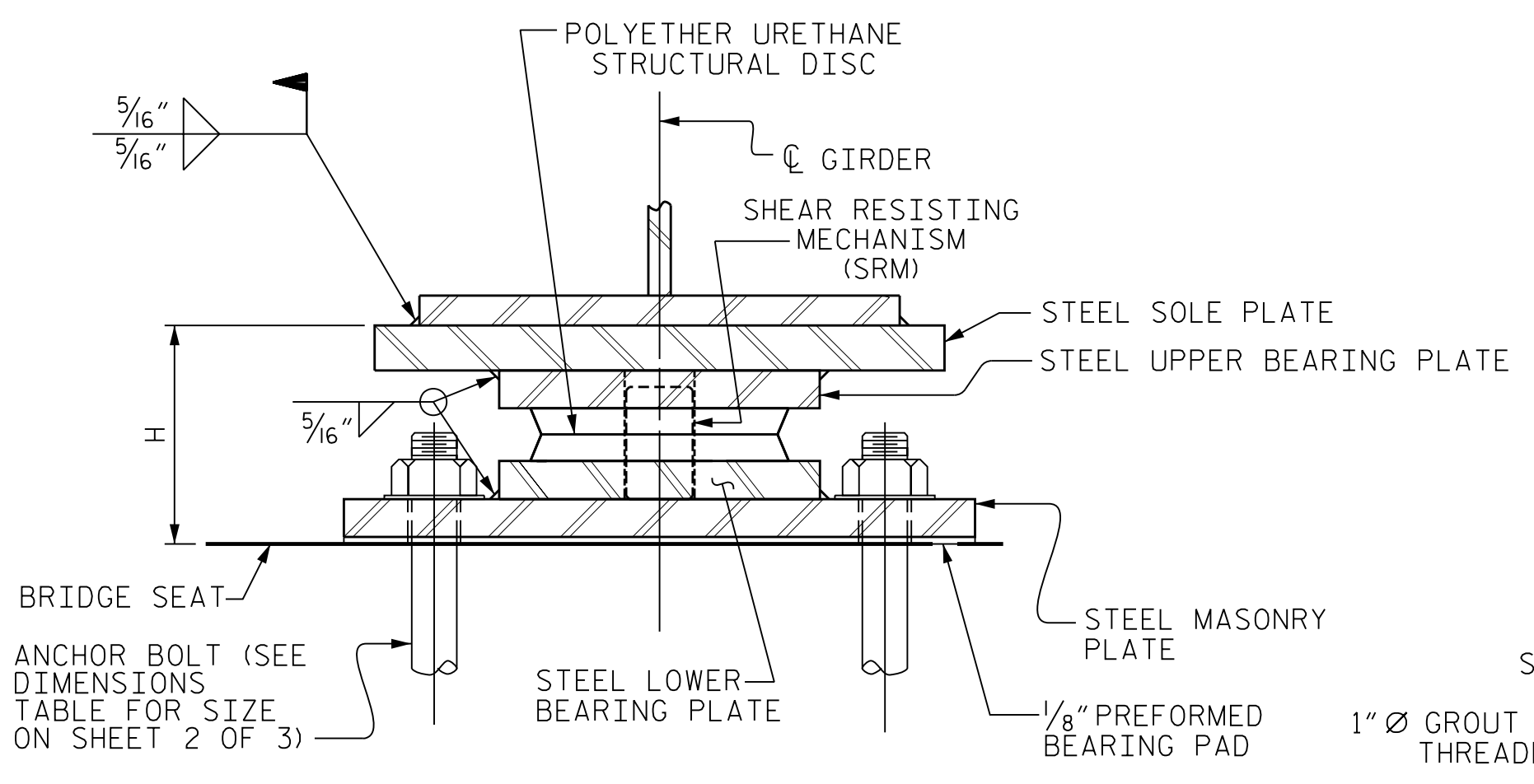

SECTION A-A  
FIXED

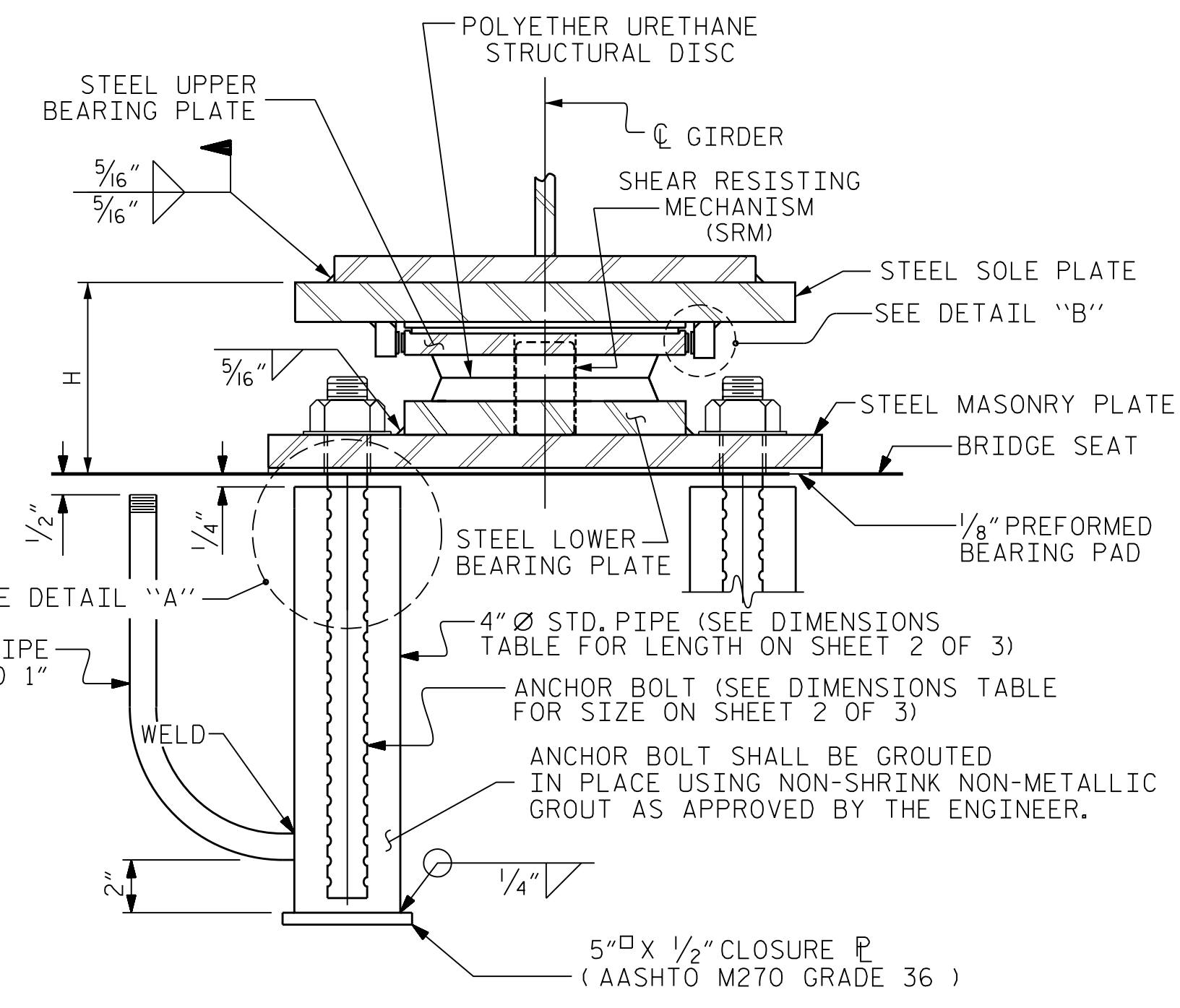

SECTION B-B  
EXPANSION

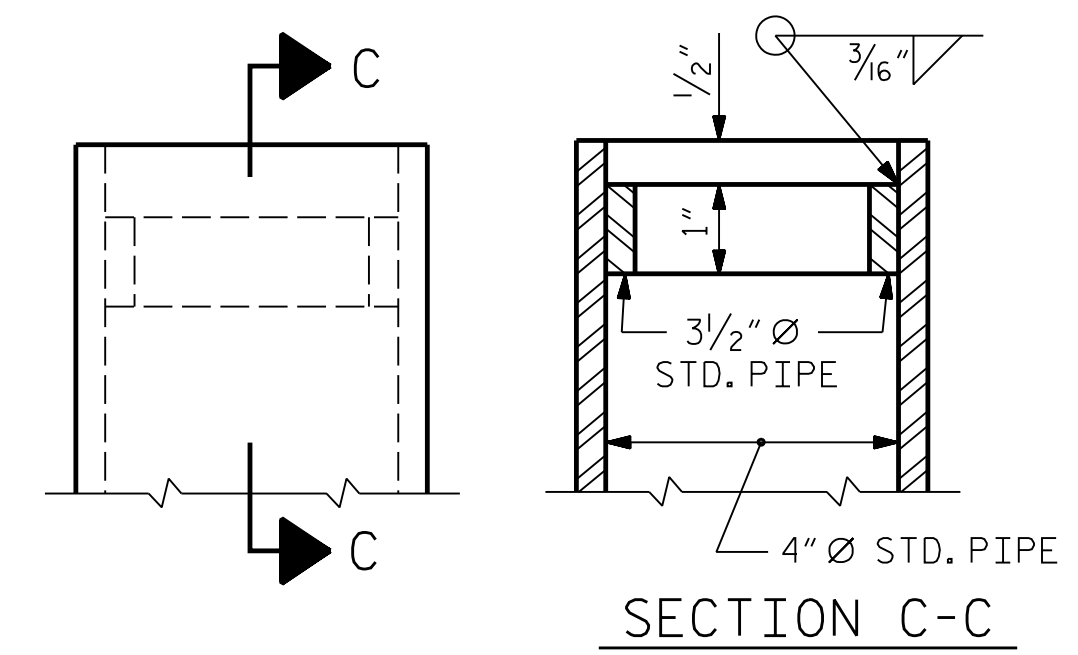

SECTION C-C

LOCATION	TEMPERATURE AT TIME OF SETTING			*
	45° F	60° F	90° F	
END BENT 1	- 5/8"	0"	1 1/4"	- 1/4"
BENT 1	- 1/2"	0"	15/16"	- 1/16"
BENT 2	- 1/4"	0"	9/16"	- 3/16"
BENT 4	- 1/4"	0"	1/2"	1/8"
BENT 5 BK	- 7/16"	0"	7/8"	- 3/16"
BEND 5 AHD	- 7/8"	0"	1 11/16"	- 1/16"
BENT 6	- 5/8"	0"	15/16"	- 1/8"
BENT 7	- 3/8"	0"	13/16"	- 3/16"
END BENT 2	- 1/4"	0"	9/16"	- 1/16"

\* CORRECTION FOR END ROTATION DUE TO WEIGHT OF SLAB AND COMPOSITE DEAD LOAD.

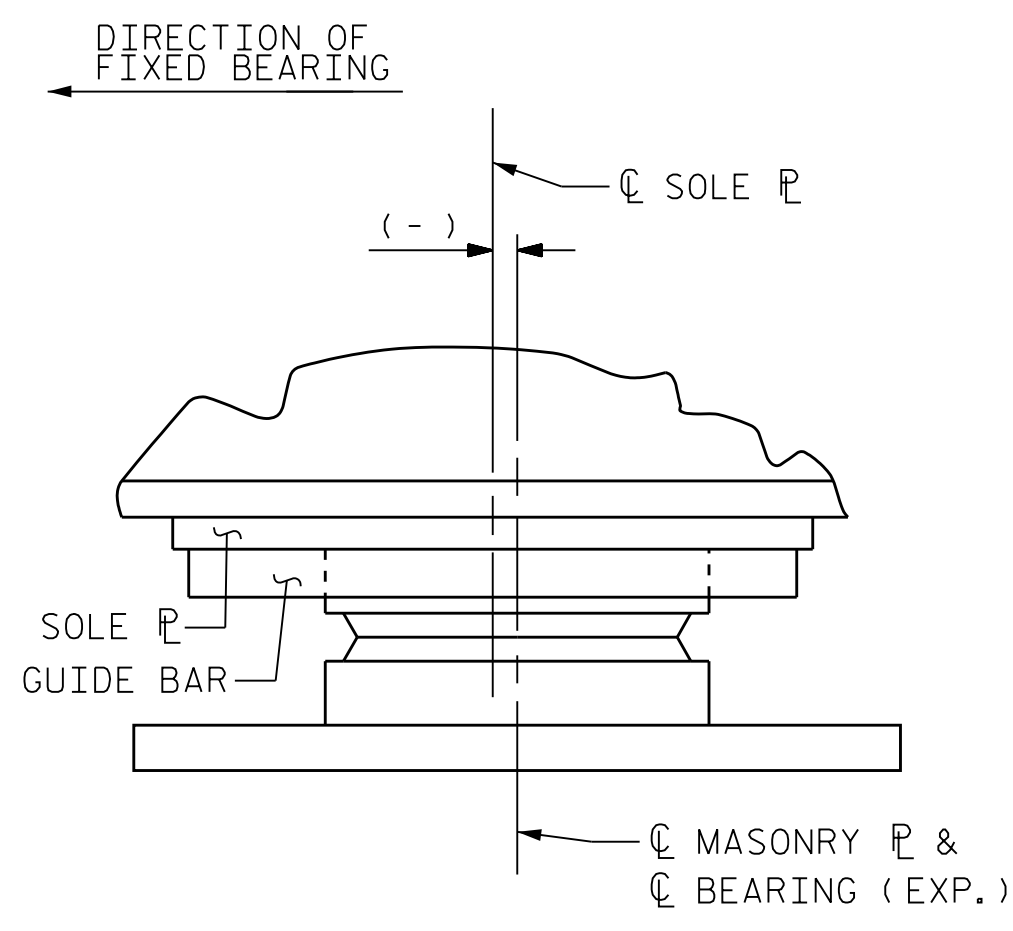

TEMPERATURE SETTING DETAIL

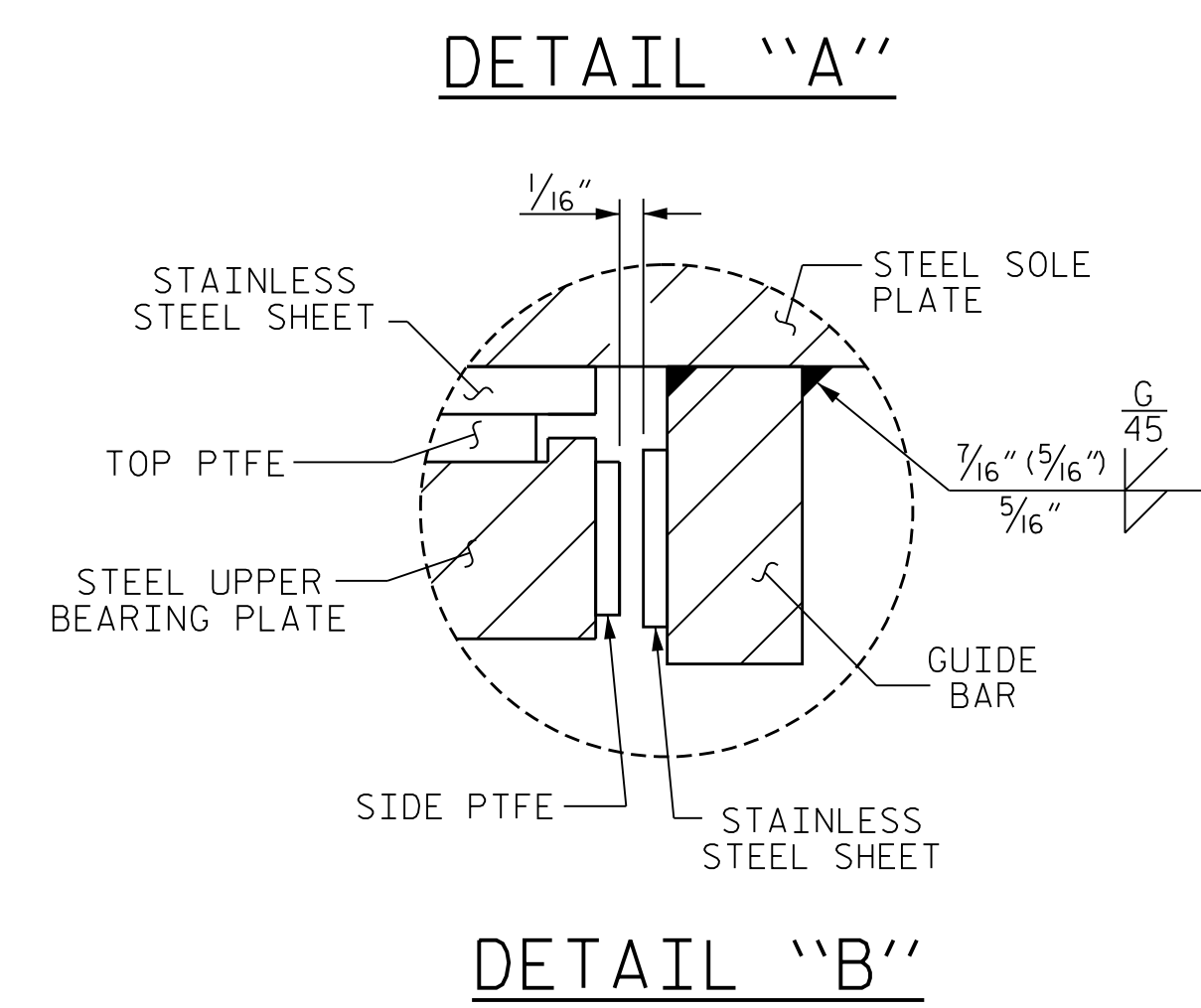

DETAIL "A"

DETAIL "B"

NOTES

- FOR DISC BEARINGS, SEE SPECIAL PROVISIONS.
- ALL BEARING PLATES SHALL BE AASHTO M270 GRADE 50W OR GRADE 50.
- AT ALL POINTS OF SUPPORT, NUTS FOR ANCHOR BOLTS SHALL BE FINGER-TIGHTENED PLUS AN ADDITIONAL 1/4 TURN. THE THREAD OF THE NUT AND BOLT SHALL THEN BE BURRED WITH A SHARP POINTED TOOL.
- WHEN WELDING THE SOLE PLATE TO THE GIRDER, USE TEMPERATURE INDICATING WAX PENS, OR OTHER SUITABLE MEANS, TO ENSURE THAT THE TEMPERATURE OF THE BEARING DOES NOT EXCEED 250°F. TEMPERATURES ABOVE THIS MAY DAMAGE THE TFE OR URETHANE DISC.
- AFTER BEARING ASSEMBLY IS IN PLACE AND ANCHOR BOLTS HAVE BEEN FINALLY POSITIONED, THEY SHALL BE GROUDED IN PLACE AS SHOWN.
- THE CLOSURE PLATE, GROUT PIPE, AND STANDARD PIPE FOR THIS ASSEMBLY NEED NOT BE GALVANIZED.
- SOLE PLATES SHOULD BE WELDED TO GIRDER FLANGES AND ANCHOR BOLTS SHOULD BE GROUDED BEFORE FALSEWORK IS PLACED.
- ALL SURFACES OF BEARING PLATES SHALL BE SMOOTH AND STRAIGHT.
- FOR ATTACHMENT OF THE STAINLESS STEEL SHEETS TO THE STEEL SOLE PLATE AND GUIDE BARS, AS WELL AS THE TOP AND SIDE PTFE SHEETS TO THE STEEL UPPER BEARING PLATE, SEE SPECIAL PROVISIONS.
- FOR THERMAL SPRAYED COATINGS (METALLIZATION), SEE SPECIAL PROVISIONS.
- THE MINIMUM ROTATIONAL CAPACITY FOR ALL BEARINGS SHALL BE 0.02 RADIAN.
- SEE SHEET 2 OF 3 FOR SOLE PLATE DETAILS.
- SEE TABLE ON SHEET 2 OF 3 FOR BEARING AND MASONRY PLATE DESIGNATIONS, LOCATIONS, BEARING HEIGHTS, MASONRY PLATE DIMENSIONS, TOP OF SOLE PLATE SLOPE, LOADS AND MOVEMENTS.
- SEE SHEET 3 OF 3 FOR EXPANSION CHORD SETTING ANGLES.

PROJECT NO. U-2579AB  
 FORSYTH COUNTY  
 STATION: 60+66.06 -Y15FLYAC-  
 SHEET 1 OF 3

STATE OF NORTH CAROLINA  
 DEPARTMENT OF TRANSPORTATION  
 RALEIGH

**SUPERSTRUCTURE  
 DISC BEARING  
 DETAILS**



10/15/2021

REVISIONS						SHEET NO. 504-060 TOTAL SHEETS 144
NO.	BY:	DATE:	NO.	BY:	DATE:	
1	--	--	3	--	--	
2	--	--	4	--	--	

**HDR** HDR Engineering, Inc. of the Carolinas  
 555 Fayetteville St., Suite 900 Raleigh, N.C. 27601  
 N.C.B.E.L.S. License Number: F-0116

DOCUMENT NOT CONSIDERED FINAL  
 UNLESS ALL SIGNATURES COMPLETED

PLOT DRIVER: NCDOT\_pdf\_color\_eng-50dpi  
 USER: PPETERSO DATE: 10/14/2021  
 FILE: ... \SUSPERS



DESIGNATIONS		LOCATION	NUMBER OF BEARINGS	DIMENSIONS											LOADS AND MOVEMENT					
BEARINGS	MASONRY			BEARING	MASONRY PLATE						SOLE PLATE	ANCHOR BOLT DIAMETER (IN.)	ANCHOR BOLT PROJECTION	TOTAL ANCHOR BOLT LENGTH	4" Ø STD. PIPE LENGTH	UNFACTORED VERTICAL LOAD (KIPS)			FACTORED HORIZONTAL LOAD (KIPS)	** ONE-WAY MOVEMENT
					H	A	B	C	D	E						F	TOP SLOPE (%)	DC		
DB1 (EXP.)	M1	END BENT 1	4	5 5/8"	2'-1 1/2"	2'-1 1/2"	3/4"	1'-7 1/2"	1'-7 1/2"	1 15/16"	- 0.4937	1 1/2"	2 1/8"	1'-6"	1'-3 1/4"	123	16	127	51	4 1/8"
DB2 (EXP.)	M2	BENT 1	4	7 3/4"	2'-8 1/2"	2'-8 1/2"	1"	2'-2 1/2"	2'-2 1/2"	1 15/16"	- 0.4937	1 1/2"	2 1/8"	1'-6 1/4"	1'-3 1/4"	365	52	239	135	3 7/8"
DB3 (EXP.)	M3	BENT 2	4	8 3/4"	3'-0"	3'-0"	1"	2'-6"	2'-6"	2 7/16"	- 0.4937	2"	2 1/2"	1'-10"	1'-6 1/4"	542	71	275	188	1 3/16"
DB4 (EXP.)	M3	BENT 4	4	8 3/4"	3'-0"	3'-0"	1"	2'-6"	2'-6"	2 7/16"	- 0.4937	2"	2 1/2"	1'-10"	1'-6 1/4"	510	70	270	179	1 9/16"
DB5 (EXP.)	M4	BENT 5 BK	4	6"	2'-3"	2'-3"	3/4"	1'-9"	1'-9"	1 15/16"	- 0.4937	1 1/2"	2 1/8"	1'-6"	1'-3 1/4"	170	22	131	65	2 5/16"
DB6 (EXP.)	M4	BENT 5 AHD	4	6"	2'-3"	2'-3"	3/4"	1'-9"	1'-9"	1 15/16"	- 0.4937	1 1/2"	2 1/8"	1'-6"	1'-3 1/4"	159	22	136	63	5 3/4"
DB7 (EXP.)	M5	BENT 6	4	8 7/8"	3'-2"	3'-2"	1 1/4"	2'-8"	2'-8"	2 7/16"	- 0.4937	2"	2 1/2"	1'-10"	1'-6 1/4"	559	72	284	194	4 3/8"
DB8 (EXP.)	M6	BENT 7	4	9 1/2"	3'-4"	3'-4"	1 1/4"	2'-10"	2'-10"	2 7/16"	- 0.4937	2"	2 1/2"	1'-10"	1'-6 1/4"	664	81	301	224	2 5/16"
DB9 (FIXED)	M7	BENT 8	4	7 3/4"	2'-8"	2'-8"	1 1/4"	2'-2"	2'-2"	2 7/16"	- 0.4937	2"	2 1/2"	1'-10"	N/A	580	74	290	200	0"
DB10 (FIXED)	M8	BENT 9	4	7 1/8"	2'-4 1/2"	2'-4 1/2"	1"	1'-10 1/2"	1'-10 1/2"	2 7/16"	- 0.4937	2"	2 1/2"	1'-10"	N/A	419	57	254	151	0"
DB11 (EXP.)	M1	END BENT 2	4	5 5/8"	2'-1 1/2"	2'-1 1/2"	3/4"	1'-7 1/2"	1'-7 1/2"	1 15/16"	- 0.4937	1 1/2"	2 1/8"	1'-6"	1'-3 1/4"	133	18	122	53	1 3/16"

\*\* "ONE-WAY MOVEMENT" REPRESENTS THE FULL MOVEMENT RANGE EXPECTED TO OCCUR OVER A TEMPERATURE RANGE FROM 10° F TO 110° F. THE BEARING SOLE PLATE AND UPPER SLIDING SURFACE SHOULD BE CENTERED ON THE BEARING AT 60° F. SEE TABLE FOR "PLATE SETTING DATA" FOR SETTING DATA FOR OTHER TEMPERATURES.

▲ ANCHOR BOLT PROJECTION IS MEASURED ABOVE TOP OF BEARING SEAT CONCRETE.

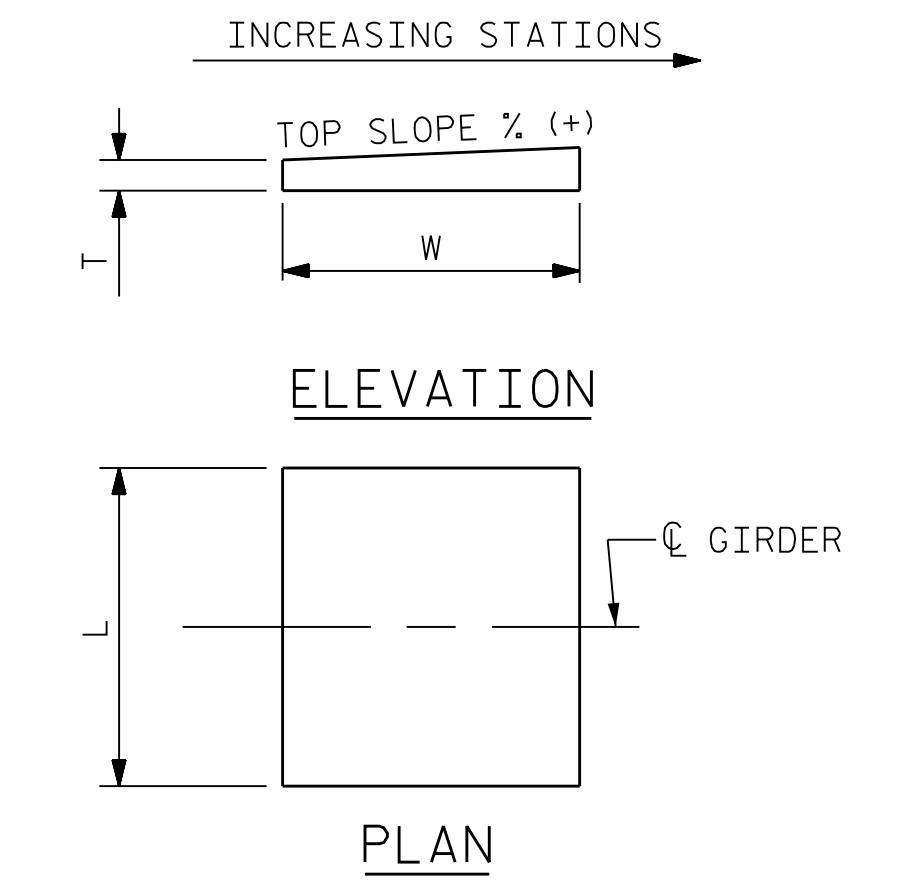
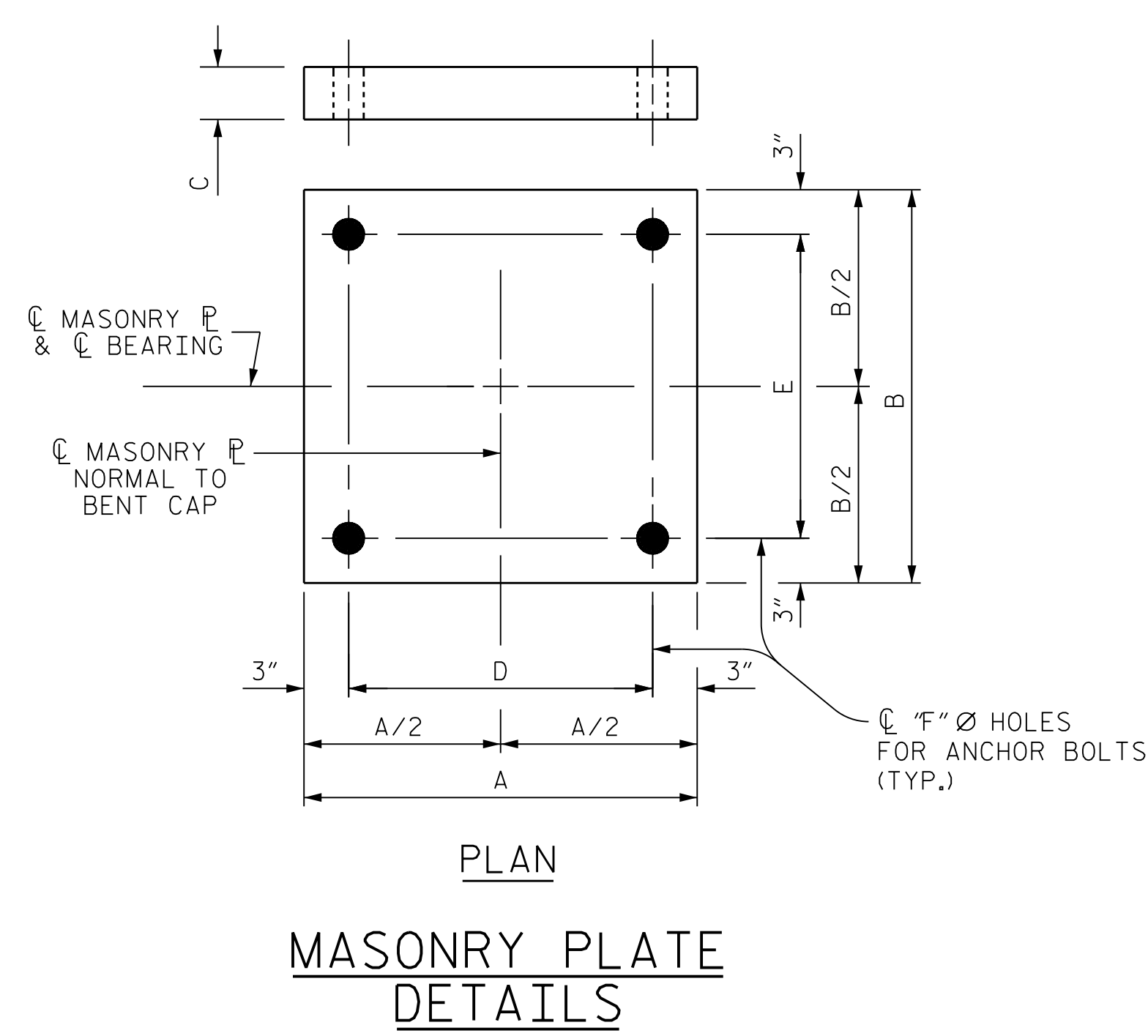

NOTE: DIMENSIONS "L", "W", AND "T" SHALL BE DETERMINED BY THE BEARING MANUFACTURER. SET DIMENSION "L" SUCH THAT THE MINIMUM EDGE DISTANCE TO THE GIRDER FLANGE IS 1".

PROJECT NO. U-2579AB  
 FORSYTH COUNTY  
 STATION: 60+66.06 -Y15FLYAC-  
 SHEET 2 OF 3



STATE OF NORTH CAROLINA  
 DEPARTMENT OF TRANSPORTATION  
 RALEIGH

**SUPERSTRUCTURE  
 DISC BEARING  
 DETAILS**

REVISIONS						SHEET NO.	
NO.	BY:	DATE:	NO.	BY:	DATE:	S04-061	
1	--	--	3	--	--	TOTAL SHEETS 144	
2	--	--	4	--	--		

DES BY: <u>G. SCHMITZ</u>	DATE: <u>07/19</u>	DWG BY: <u>B. PETERSON</u>	DATE: <u>07/19</u>
DES CHK: <u>D. COLETTI</u>	DATE: <u>07/19</u>	CHK BY: <u>D. OLDS</u>	DATE: <u>11/19</u>

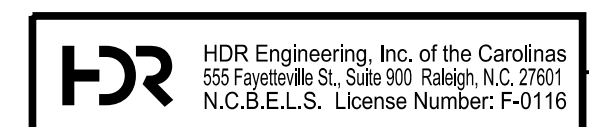

10/15/2021  
 DOCUMENT NOT CONSIDERED FINAL  
 UNLESS ALL SIGNATURES COMPLETED

PLOT DRIVER: NCDOT\_pdf\_color\_eng-50dpi  
 USER: PPETERSO  
 FILE: ... \SUPERS  
 PENTABLE: NCDOT\_STRUCTURES\_DEFAULT\_PEN.tbl  
 TIME: 4:02:18 PM  
 DATE: 10/14/2021

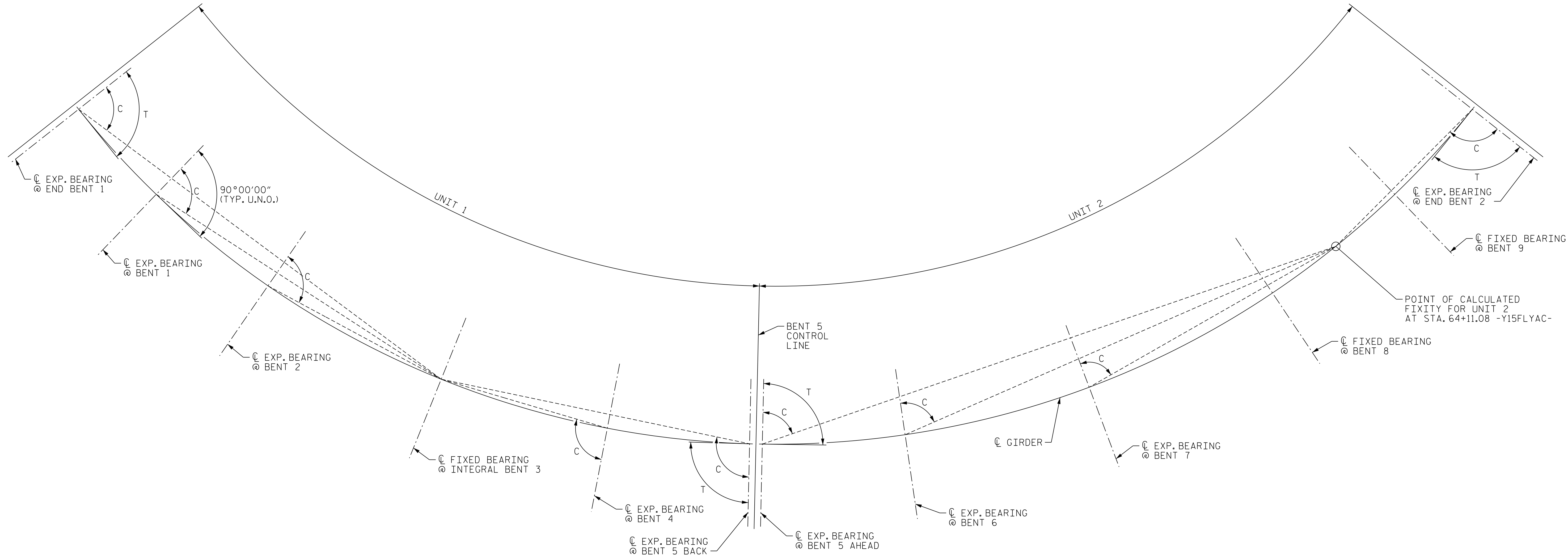

EXPANSION BEARING ORIENTATION DIAGRAM

EXPANSION CHORD SETTING ANGLES													
LOCATION	END BENT 1		BENT 1	BENT 2	BENT 4	BENT 5 (BACK)		BENT 5 (AHEAD)		BENT 6	BENT 7	END BENT 2	
	T	C	C	C	C	T	C	T	C	C	C	T	C
GIRDERS 1-4	89°57'19"	85°48'48"	86°51'12"	88°11'03"	91°35'48"	90°01'39"	92°59'17"	89°58'21"	84°12'55"	85°36'24"	87°21'35"	90°02'39"	91°51'04"

**NOTES**  
 C = ANGLE FROM  $\phi$  BRG TO EXPANSION CHORD  
 T = ANGLE FROM  $\phi$  BRG TO LOCAL TANGENT TO CURVE

PROJECT NO. U-2579AB  
FORSYTH COUNTY  
 STATION: 60+66.06 -Y15FLYAC-  
 SHEET 3 OF 3

STATE OF NORTH CAROLINA  
 DEPARTMENT OF TRANSPORTATION  
 RALEIGH

**SUPERSTRUCTURE  
 DISC BEARING  
 DETAILS**



REVISIONS						SHEET NO. S04-062 TOTAL SHEETS 144
NO.	BY:	DATE:	NO.	BY:	DATE:	
1	--	--	3	--	--	
2	--	--	4	--	--	

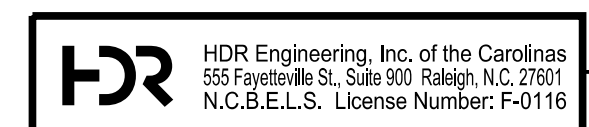

10/15/2021  
 DOCUMENT NOT CONSIDERED FINAL  
 UNLESS ALL SIGNATURES COMPLETED

PLOT DRIVER: NCDOT\_pdf\_color\_eng-50dpi  
 USER: PPETERSO DATE: 10/14/2021  
 PENTABLE: NCDOT\_STRUCTURES\_DEFAULT\_PEN.tbl  
 TIME: 4:02:27 PM  
 FILE: ... \SUPERS

DES BY: <u>G. SCHMITZ</u>	DATE: <u>07/19</u>	DWG BY: <u>B. PETERSON</u>	DATE: <u>07/19</u>
DES CHK: <u>D. COLETTI</u>	DATE: <u>07/19</u>	CHK BY: <u>D. OLDS</u>	DATE: <u>11/19</u>























PLOT DRIVER: NCDOT... PENTABLE: NCDOT STRUCTURES DEFAULT PEN.tbl  
USER: PPRET0... DATE: 10/14/2021  
FILE: ... \SUPERS

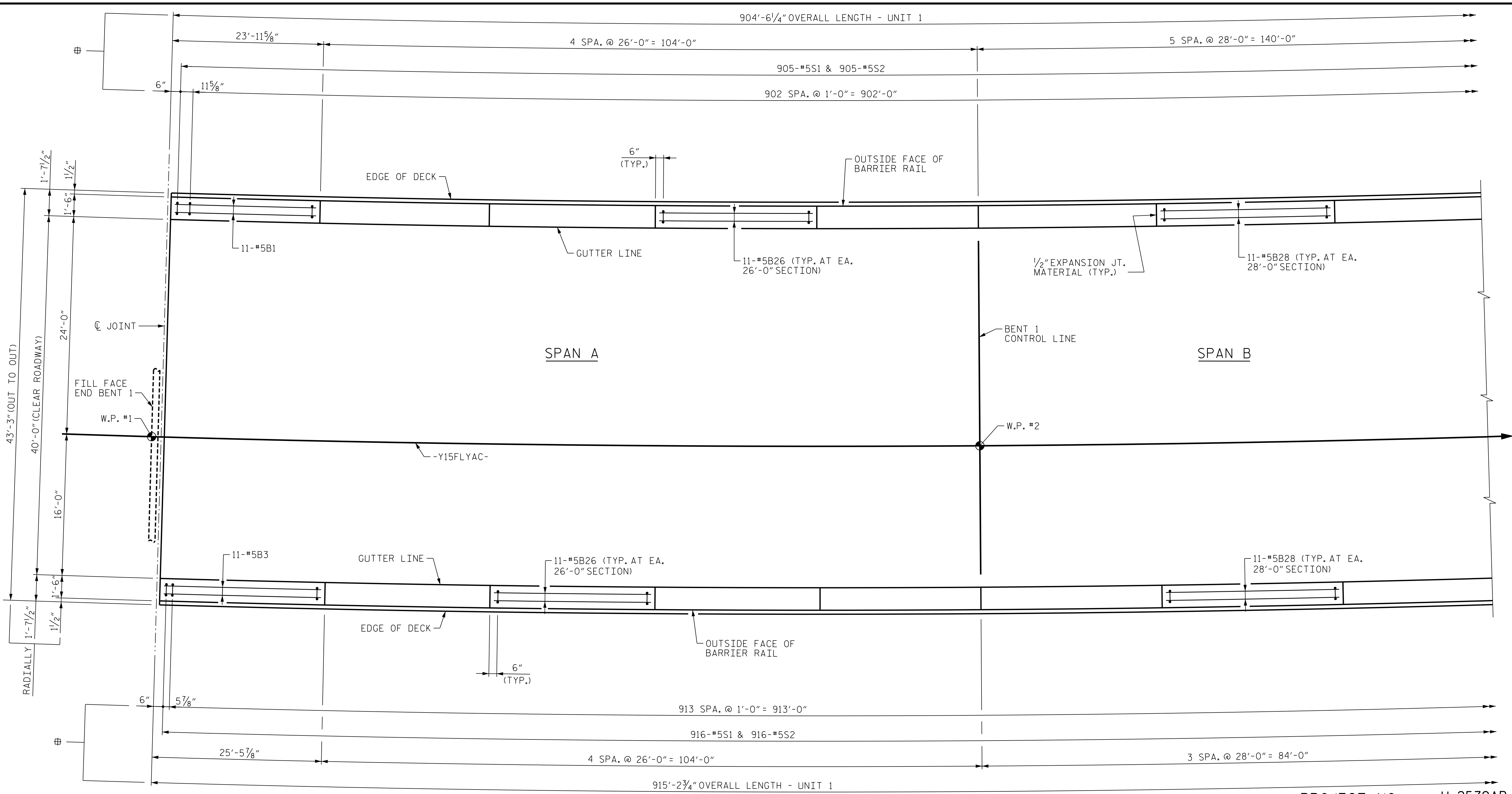

SEE SHEET 2 OF 4

### PARTIAL PLAN OF BARRIER RAIL - UNIT 1

# = MEASURED ALONG OUTSIDE FACE OF BARRIER RAIL

PROJECT NO. U-2579AB  
 FORSYTH COUNTY  
 STATION: 60+66.06 -Y15FLYAC-  
 SHEET 1 OF 4

STATE OF NORTH CAROLINA  
 DEPARTMENT OF TRANSPORTATION  
 RALEIGH

**SUPERSTRUCTURE  
 CONCRETE BARRIER RAIL  
 UNIT 1**



DES BY: <u>L. ZAMPETTI</u>	DATE: <u>07/19</u>	DWG BY: <u>B. PETERSON</u>	DATE: <u>07/19</u>
DES CHK: <u>J. ROBERTS</u>	DATE: <u>07/19</u>	CHK BY: <u>S. NIFONG</u>	DATE: <u>11/19</u>

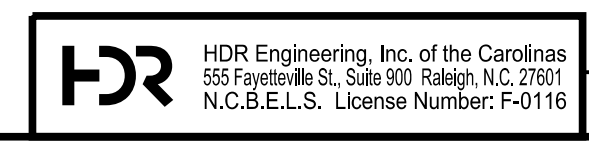

REVISIONS

NO.	BY:	DATE:	NO.	BY:	DATE:
1	--	--	3	--	--
2	--	--	4	--	--

DOCUMENT NOT CONSIDERED FINAL  
UNLESS ALL SIGNATURES COMPLETED

SHEET NO. <u>504-073</u>
TOTAL SHEETS <u>144</u>

PLOT DRIVER: NCDOT\_PDF\_PEN...  
 USER: PPETERSO  
 DATE: 10/14/2021  
 TIME: 4:03:16 PM  
 FILE: ... \SUPERS

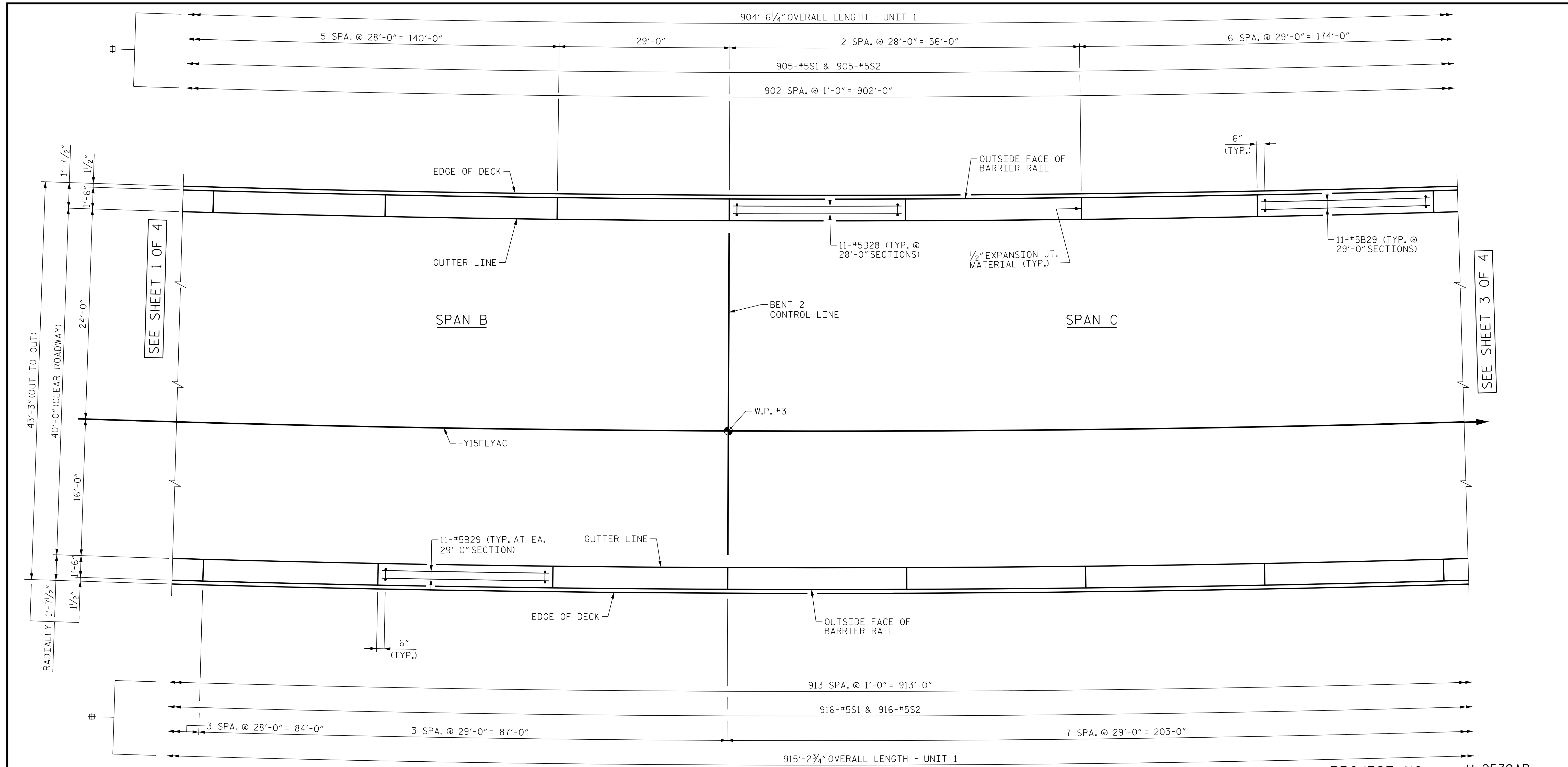

**PARTIAL PLAN OF BARRIER RAIL - UNIT 1**

⊕ = MEASURED ALONG OUTSIDE FACE OF BARRIER RAIL

PROJECT NO. U-2579AB  
 FORSYTH COUNTY  
 STATION: 60+66.06 -Y15FLYAC-  
 SHEET 2 OF 4

STATE OF NORTH CAROLINA  
 DEPARTMENT OF TRANSPORTATION  
 RALEIGH  
**SUPERSTRUCTURE  
 CONCRETE BARRIER RAIL  
 UNIT 1**



*Domenic A. Colletti* 10/15/2021

DES BY: <u>L. ZAMPETTI</u>	DATE: <u>07/19</u>	DWG BY: <u>B. PETERSON</u>	DATE: <u>07/19</u>
DES CHK: <u>J. ROBERTS</u>	DATE: <u>07/19</u>	CHK BY: <u>S. NIFONG</u>	DATE: <u>11/19</u>

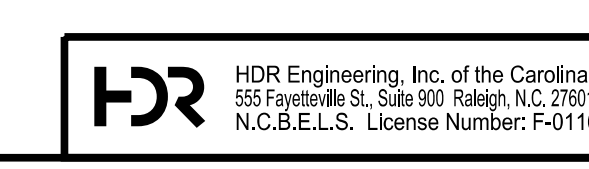

**DOCUMENT NOT CONSIDERED FINAL  
 UNLESS ALL SIGNATURES COMPLETED**

REVISIONS						SHEET NO.	
NO.	BY:	DATE:	NO.	BY:	DATE:	TOTAL SHEETS	
1	--	--	3	--	--	144	
2	--	--	4	--	--	144	

PLOT DRIVER: NCDOT... PENTABLE: NCDOT\_STRUCTURES\_DEFAULT\_PEN.tbl  
 USER: PPETERSO DATE: 10/14/2021 TIME: 4:03:19 PM  
 FILE: ... \SUPERS

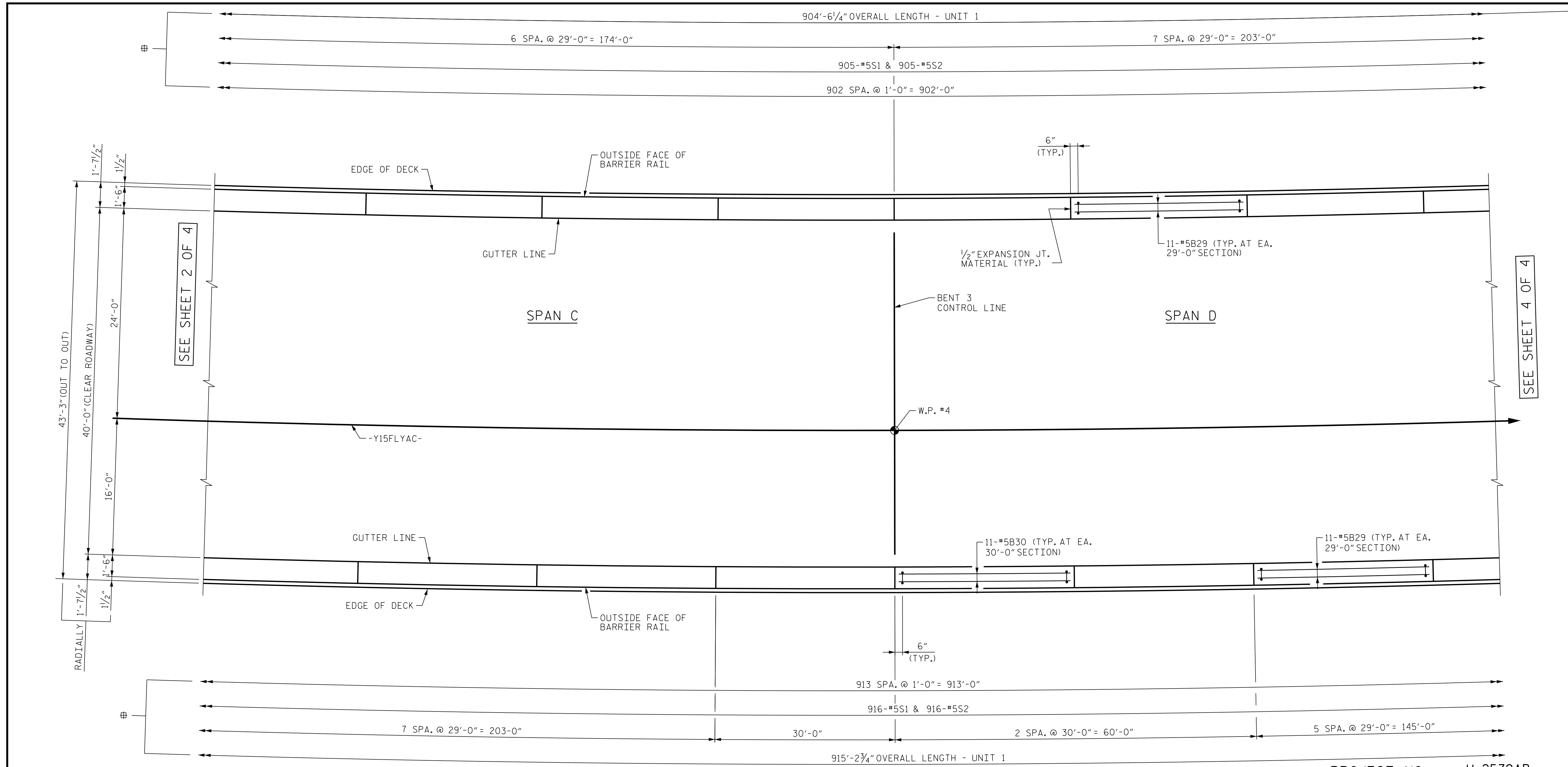

**PARTIAL PLAN OF BARRIER RAIL - UNIT 1**  
 # = MEASURED ALONG OUTSIDE FACE OF BARRIER RAIL

PROJECT NO. U-2579AB  
 FORSYTH COUNTY  
 STATION: 60+66.06 -Y15FLYAC-  
 SHEET 3 OF 4

STATE OF NORTH CAROLINA  
 DEPARTMENT OF TRANSPORTATION  
 RALEIGH

**SUPERSTRUCTURE  
 CONCRETE BARRIER RAIL  
 UNIT 1**



DES BY: <u>L. ZAMPETTI</u>	DATE: <u>07/19</u>	DWG BY: <u>B. PETERSON</u>	DATE: <u>07/19</u>
DES CHK: <u>J. ROBERTS</u>	DATE: <u>07/19</u>	CHK BY: <u>S. NIFONG</u>	DATE: <u>11/19</u>

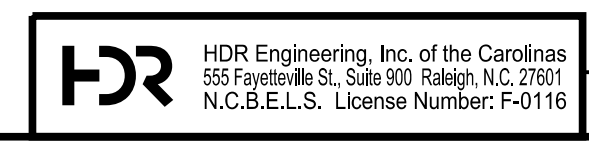

10/15/2021  
**DOCUMENT NOT CONSIDERED FINAL  
 UNLESS ALL SIGNATURES COMPLETED**

REVISIONS						SHEET NO. 504-075 TOTAL SHEETS 144
NO.	BY:	DATE:	NO.	BY:	DATE:	
1	--	--	3	--	--	
2	--	--	4	--	--	

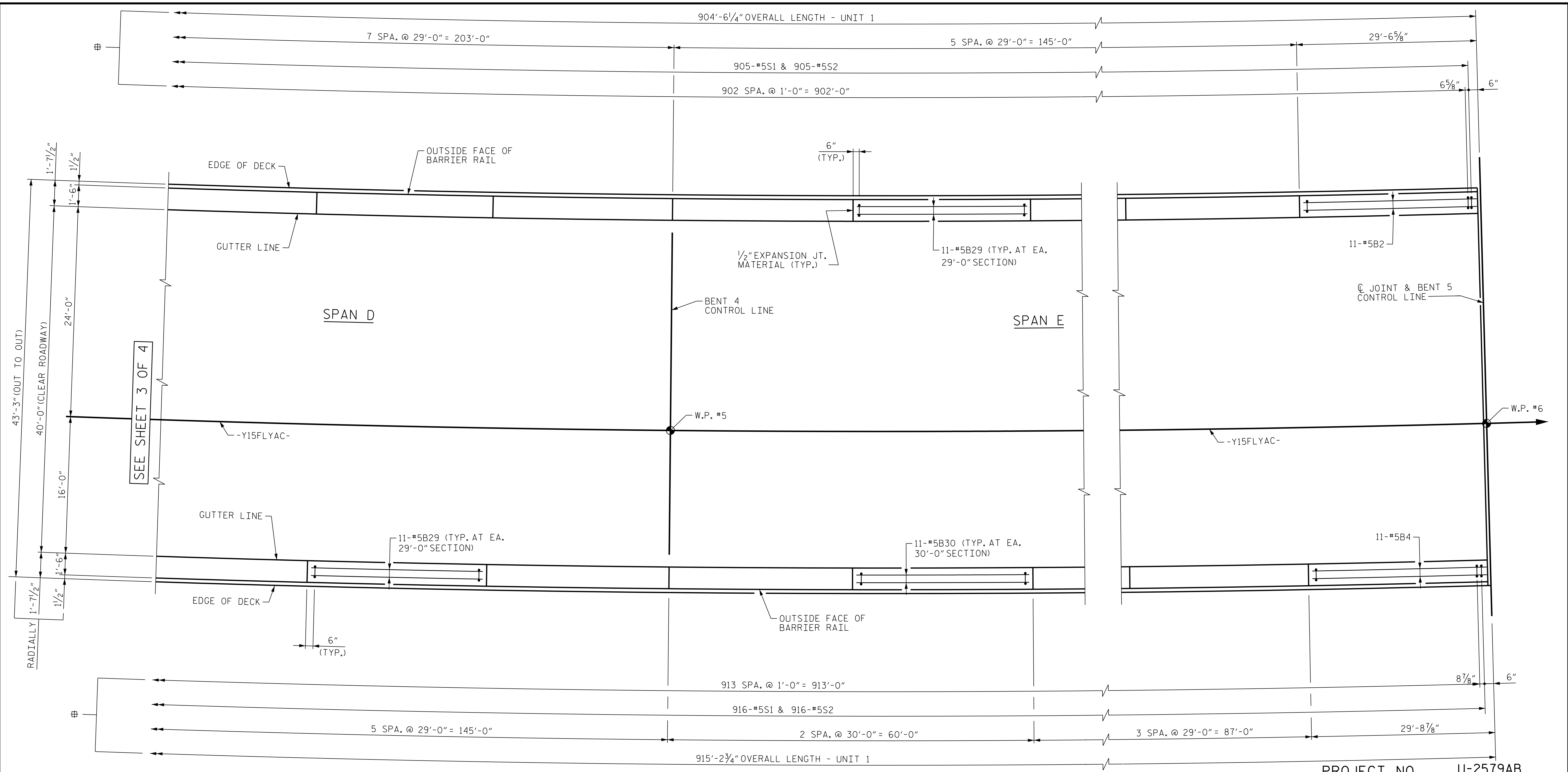

**PARTIAL PLAN OF BARRIER RAIL - UNIT 1**  
 # = MEASURED ALONG OUTSIDE FACE OF BARRIER RAIL

PROJECT NO. U-2579AB  
 FORSYTH COUNTY  
 STATION: 60+66.06 -Y15FLYAC-  
 SHEET 4 OF 4

STATE OF NORTH CAROLINA  
 DEPARTMENT OF TRANSPORTATION  
 RALEIGH

**SUPERSTRUCTURE  
 CONCRETE BARRIER RAIL  
 UNIT 1**

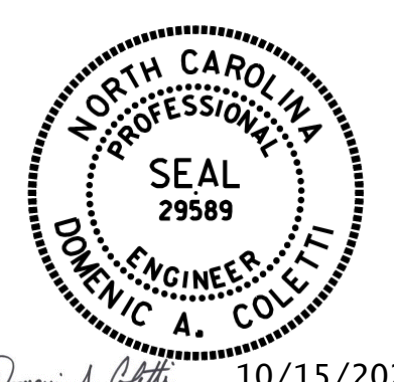

*Dominic A. Colletti* 10/15/2021

REVISIONS						SHEET NO.	
NO.	BY:	DATE:	NO.	BY:	DATE:	NO.	DATE:
1	--	--	3	--	--	TOTAL	
2	--	--	4	--	--	SHEETS	144

**HDR** HDR Engineering, Inc. of the Carolinas  
 555 Fayetteville St., Suite 900 Raleigh, N.C. 27601  
 N.C.B.E.L.S. License Number: F-0116

**DOCUMENT NOT CONSIDERED FINAL  
 UNLESS ALL SIGNATURES COMPLETED**

PLOT DRIVER: NCDOT... PENTABLE: NCDOT... USER: PPETERSO... DATE: 10/14/2021... FILE: ... \S\UPERS

DES BY: <u>L. ZAMPETTI</u>	DATE: <u>07/19</u>	DWG BY: <u>B. PETERSON</u>	DATE: <u>07/19</u>
DES CHK: <u>J. ROBERTS</u>	DATE: <u>07/19</u>	CHK BY: <u>S. NIFONG</u>	DATE: <u>11/19</u>



PLOT DRIVER: NCDOT... PENTABLE: NCDOT STRUCTURES DEFAULT PEN.tbl  
USER: PPRETerso DATE: 10/14/2021  
FILE: ... \SUPERS

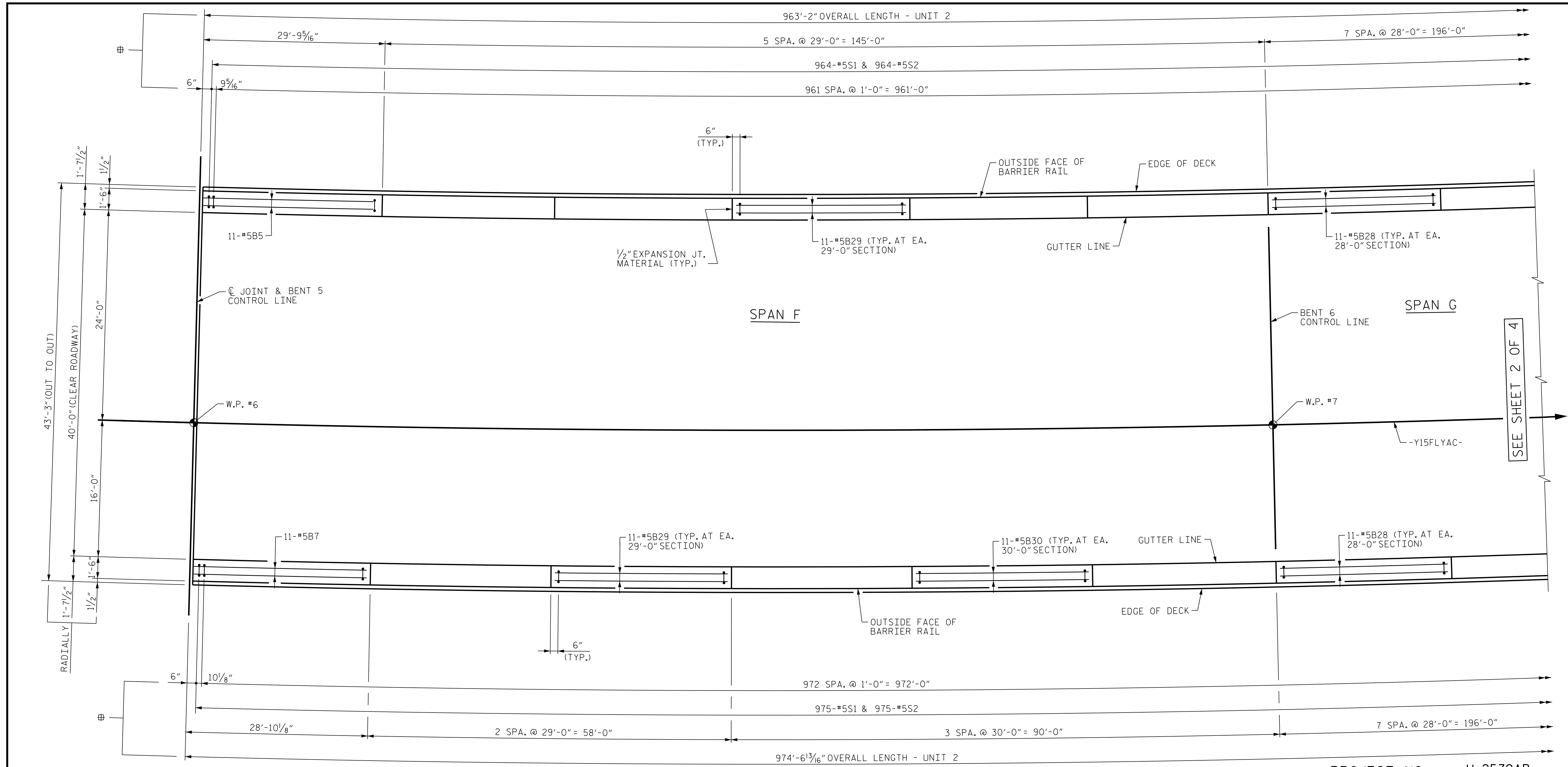

### PARTIAL PLAN OF BARRIER RAIL - UNIT 2

⊕ = MEASURED ALONG OUTSIDE FACE OF BARRIER RAIL

PROJECT NO. U-2579AB  
 FORSYTH COUNTY  
 STATION: 60+66.06 -Y15FLYAC-  
 SHEET 1 OF 4

STATE OF NORTH CAROLINA  
 DEPARTMENT OF TRANSPORTATION  
 RALEIGH

**SUPERSTRUCTURE  
 CONCRETE BARRIER RAIL  
 UNIT 2**



*Dominic A. Colletti* 10/15/2021

DES BY: <u>L. ZAMPETTI</u>	DATE: <u>07/19</u>	DWG BY: <u>B. PETERSON</u>	DATE: <u>07/19</u>
DES CHK: <u>J. ROBERTS</u>	DATE: <u>07/19</u>	CHK BY: <u>S. NIFONG</u>	DATE: <u>11/19</u>

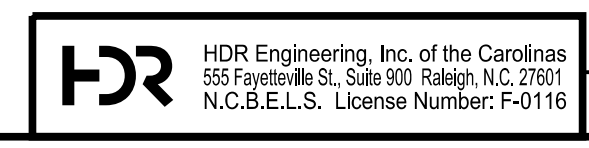

**DOCUMENT NOT CONSIDERED FINAL  
 UNLESS ALL SIGNATURES COMPLETED**

REVISIONS						SHEET NO. S04-077 TOTAL SHEETS 144
NO.	BY:	DATE:	NO.	BY:	DATE:	
1	--	--	3	--	--	
2	--	--	4	--	--	

PLOT DRIVER: NCDOT... PENTABLE: NCDOT STRUCTURES DEFAULT PEN.tbl  
 USER: PETERSON DATE: 10/14/2021  
 FILE: ... \ASUPERS

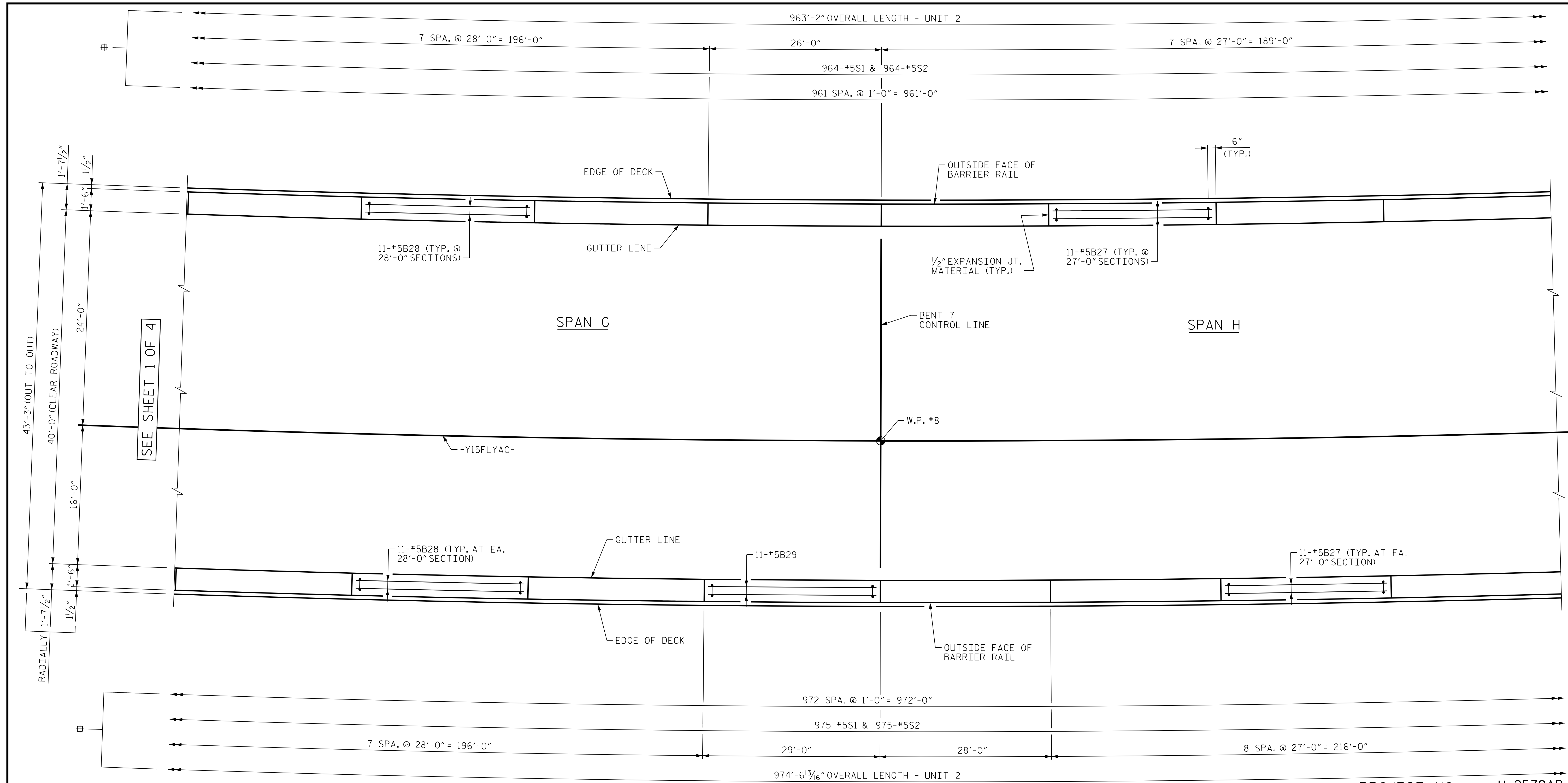

**PARTIAL PLAN OF BARRIER RAIL - UNIT 2**  
 # = MEASURED ALONG OUTSIDE FACE OF BARRIER RAIL

PROJECT NO. U-2579AB  
 FORSYTH COUNTY  
 STATION: 60+66.06 -Y15FLYAC-  
 SHEET 2 OF 4

STATE OF NORTH CAROLINA  
 DEPARTMENT OF TRANSPORTATION  
 RALEIGH

**SUPERSTRUCTURE  
 CONCRETE BARRIER RAIL  
 UNIT 2**



DES BY: <u>L. ZAMPETTI</u>	DATE: <u>07/19</u>	DWG BY: <u>B. PETERSON</u>	DATE: <u>07/19</u>
DES CHK: <u>J. ROBERTS</u>	DATE: <u>07/19</u>	CHK BY: <u>S. NIFONG</u>	DATE: <u>11/19</u>

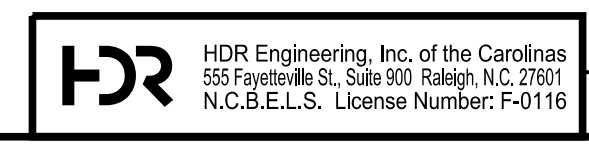

10/15/2021  
 DOCUMENT NOT CONSIDERED FINAL  
 UNLESS ALL SIGNATURES COMPLETED

REVISIONS						SHEET NO. 504-078 TOTAL SHEETS 144
NO.	BY:	DATE:	NO.	BY:	DATE:	
1	--	--	3	--	--	
2	--	--	4	--	--	

PLOT DRIVER: NCDOT\_PDF\_PDF\_color\_eng-50.ppt  
 USER: PPETERSO DATE: 10/14/2021  
 FILE: ... \SUPERS

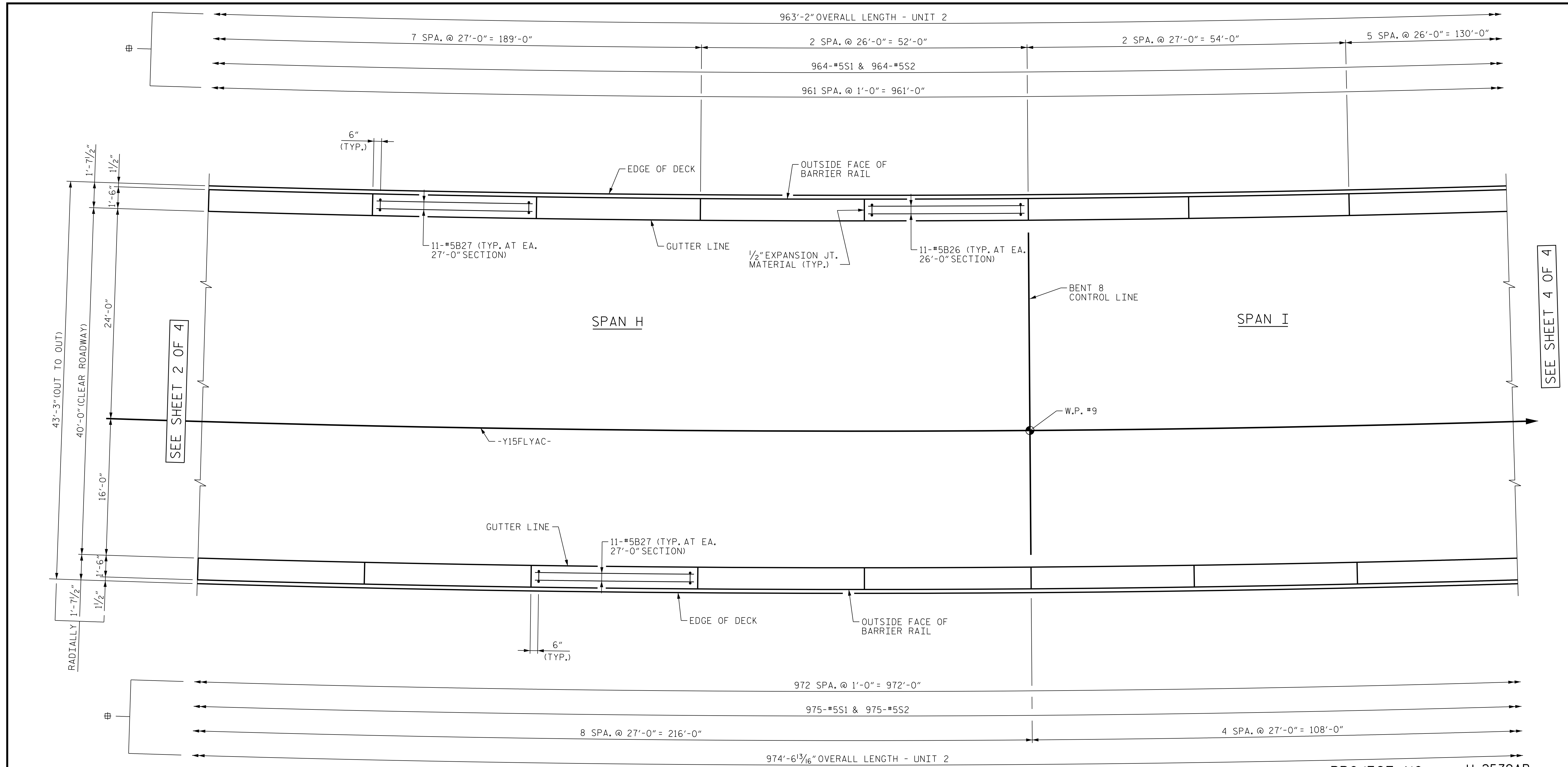

SEE SHEET 2 OF 4

SEE SHEET 4 OF 4

**PARTIAL PLAN OF BARRIER RAIL - UNIT 2**

# = MEASURED ALONG OUTSIDE FACE OF BARRIER RAIL

PROJECT NO. U-2579AB  
 FORSYTH COUNTY  
 STATION: 60+66.06 -Y15FLYAC-  
 SHEET 3 OF 4

STATE OF NORTH CAROLINA  
 DEPARTMENT OF TRANSPORTATION  
 RALEIGH

**SUPERSTRUCTURE  
 CONCRETE BARRIER RAIL  
 UNIT 2**



DES BY: <u>L. ZAMPETTI</u>	DATE: <u>07/19</u>	DWG BY: <u>B. PETERSON</u>	DATE: <u>07/19</u>
DES CHK: <u>J. ROBERTS</u>	DATE: <u>07/19</u>	CHK BY: <u>S. NIFONG</u>	DATE: <u>11/19</u>

**HDR** HDR Engineering, Inc. of the Carolinas  
 555 Fayetteville St., Suite 900 Raleigh, N.C. 27601  
 N.C.B.E.L.S. License Number: F-0116

10/15/2021  
**DOCUMENT NOT CONSIDERED FINAL  
 UNLESS ALL SIGNATURES COMPLETED**

REVISIONS						SHEET NO. 504-079 TOTAL SHEETS 144
NO.	BY:	DATE:	NO.	BY:	DATE:	
1	--	--	3	--	--	
2	--	--	4	--	--	

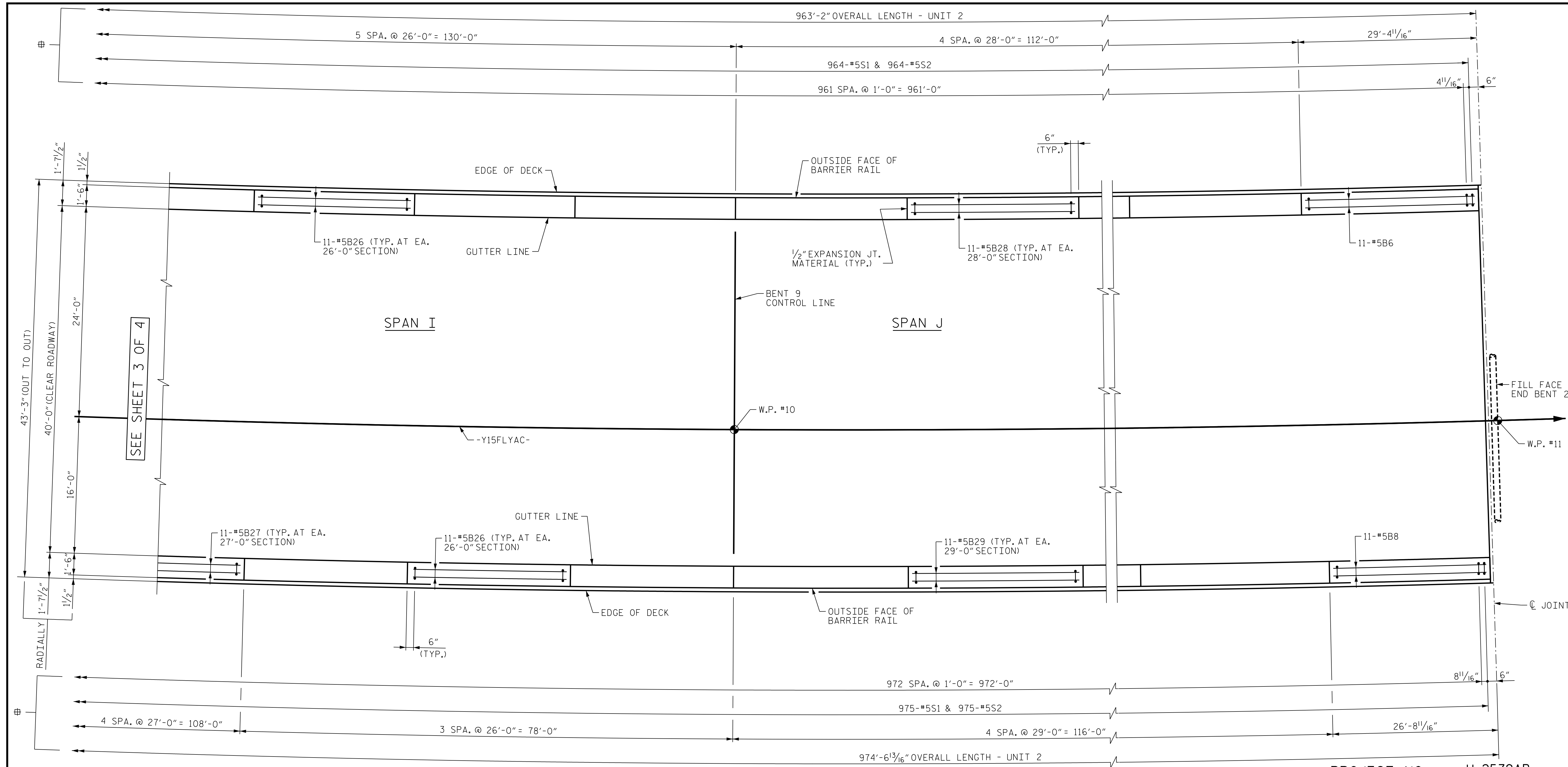

**PARTIAL PLAN OF BARRIER RAIL - UNIT 2**

# = MEASURED ALONG OUTSIDE FACE OF BARRIER RAIL

PROJECT NO. U-2579AB  
 FORSYTH COUNTY  
 STATION: 60+66.06 -Y15FLYAC-  
 SHEET 4 OF 4

STATE OF NORTH CAROLINA  
 DEPARTMENT OF TRANSPORTATION  
 RALEIGH

**SUPERSTRUCTURE  
 CONCRETE BARRIER RAIL  
 UNIT 2**

REVISIONS						SHEET NO.	
NO.	BY:	DATE:	NO.	BY:	DATE:	NO.	DATE:
1	--	--	3	--	--	TOTAL	
2	--	--	4	--	--	SHEETS	144



*Dominic A. Coletti* 10/15/2021



**DOCUMENT NOT CONSIDERED FINAL  
 UNLESS ALL SIGNATURES COMPLETED**

PLOT DRIVER: NCDOT... PENTABLE: NCDOT STRUCTURES DEFAULT PEN.tbl  
 USER: PETERSON DATE: 10/14/2021  
 FILE: ... \SUPERS

DES BY: <u>L. ZAMPETTI</u>	DATE: <u>07/19</u>	DWG BY: <u>B. PETERSON</u>	DATE: <u>07/19</u>
DES CHK: <u>J. ROBERTS</u>	DATE: <u>07/19</u>	CHK BY: <u>S. NIFONG</u>	DATE: <u>11/19</u>

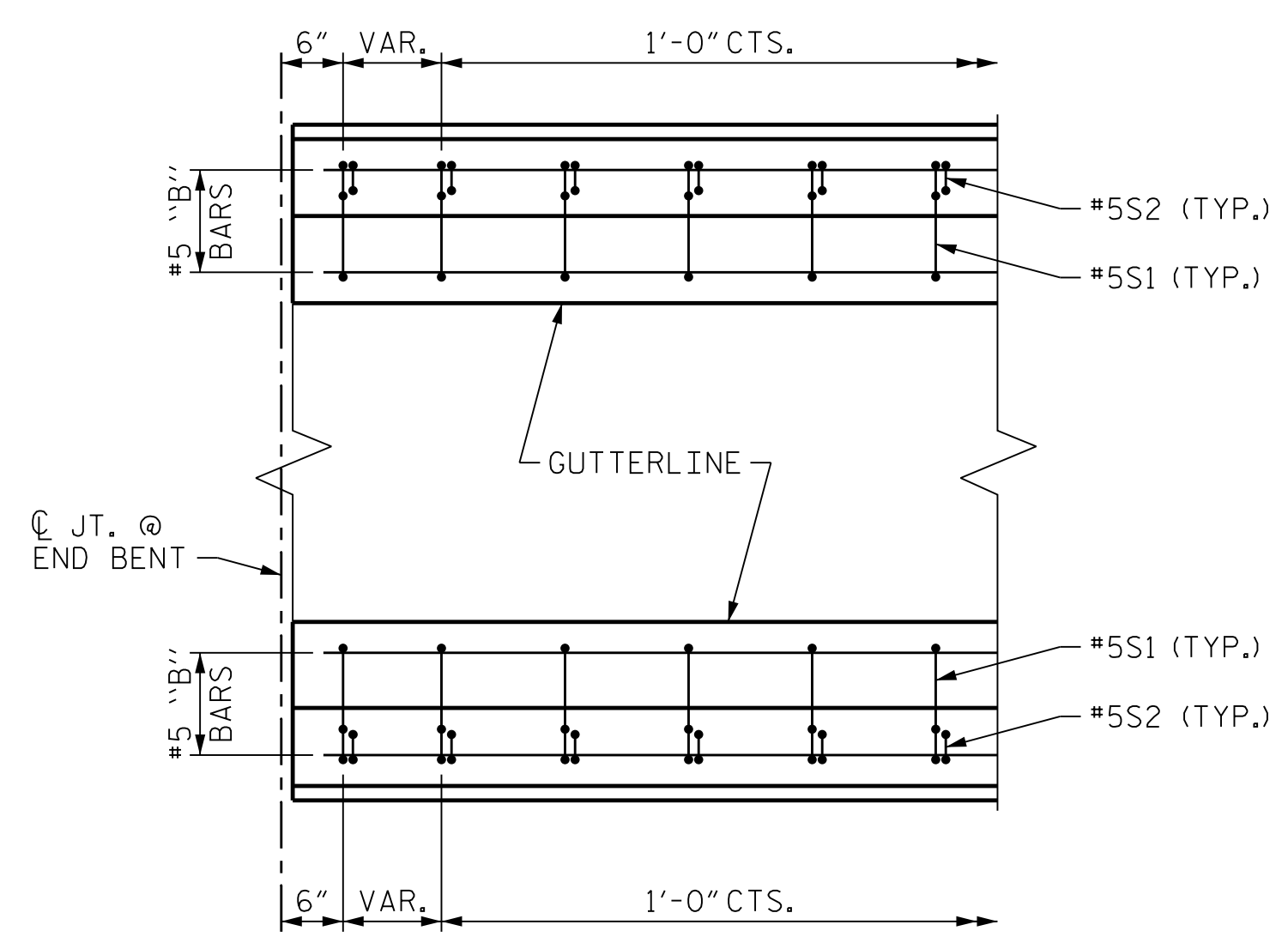

**PLAN**  
RAIL DETAILS AT EXPANSION JOINTS

**NOTES**

THE BARRIER RAIL IN EACH UNIT SHALL NOT BE CAST UNTIL ALL SLAB CONCRETE IN THAT UNIT HAS BEEN CAST AND HAS REACHED A MINIMUM COMPRESSIVE STRENGTH OF 3,000 PSI.

ALL REINFORCING STEEL IN BARRIER RAILS SHALL BE EPOXY COATED.

GROOVED CONTRACTION JOINTS, 1/2" IN DEPTH, SHALL BE TOOLED IN ALL EXPOSED FACES OF THE BARRIER RAIL AND IN ACCORDANCE WITH ARTICLE 825-10(B) OF THE STANDARD SPECIFICATIONS. THE CONTRACTION JOINT SHALL BE LOCATED AT EACH THIRD POINT BETWEEN BARRIER RAIL EXPANSION JOINTS. ONLY ONE CONTRACTION JOINT IS REQUIRED AT MIDPOINT OF BARRIER RAIL SEGMENTS LESS THAN 20 FEET IN LENGTH AND NO CONTRACTION JOINTS ARE REQUIRED FOR THOSE SEGMENTS LESS THAN 10 FEET IN LENGTH.

SEE "BRIDGE APPROACH SLAB" SHEETS FOR BARRIER RAIL CONSTRUCTED ON APPROACH SLABS AND END OF RAIL DETAILS.

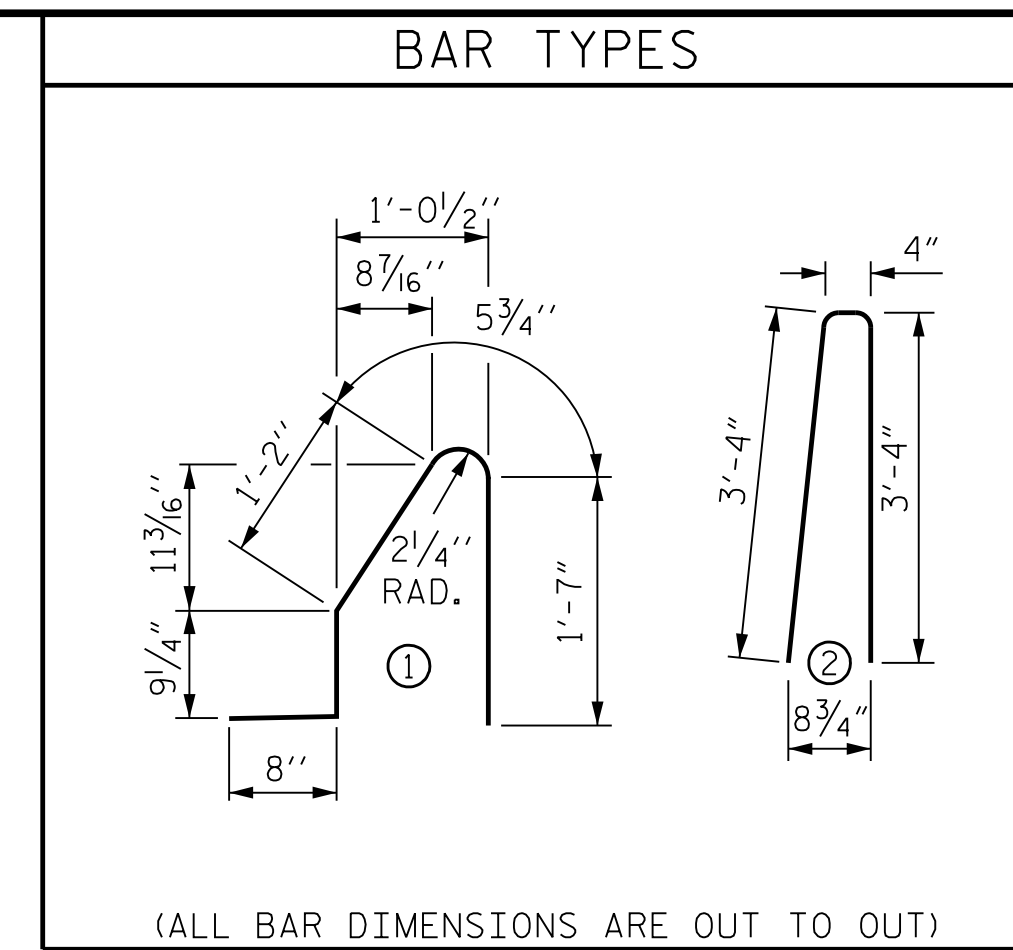

BILL OF MATERIAL					
FOR CONCRETE BARRIER RAIL ON BRIDGE DECK ONLY					
UNIT 1					
BAR NO.	SIZE	TYPE	LENGTH	WEIGHT	
*B1	11	# 5	23'-5"	269	
*B2	11	# 5	28'-11"	332	
*B3	11	# 5	25'-0"	287	
*B4	11	# 5	29'-1"	334	
*B26	88	# 5	25'-7"	2,349	
*B28	110	# 5	27'-7"	3,165	
*B29	407	# 5	28'-7"	12,134	
*B30	55	# 5	29'-7"	1,698	
*S1	1,821	# 5	1	4'-8"	8,864
*S2	1,821	# 5	2	7'-0"	13,296

\* EPOXY COATED REINFORCING STEEL 42,728 LBS.  
CLASS AA CONCRETE 247.3 CU. YDS.  
CONCRETE BARRIER RAIL 1,819.8 LIN. FT.

UNIT 2					
BAR NO.	SIZE	TYPE	LENGTH	WEIGHT	
*B5	11	# 5	29'-2"	335	
*B6	11	# 5	28'-11"	332	
*B7	11	# 5	28'-3"	325	
*B8	11	# 5	26'-3"	302	
*B26	121	# 5	25'-7"	3,229	
*B27	231	# 5	26'-7"	6,405	
*B28	209	# 5	27'-7"	6,013	
*B29	132	# 5	28'-7"	3,936	
*B30	33	# 5	29'-7"	1,019	
*S1	1,939	# 5	1	4'-8"	9,438
*S2	1,939	# 5	2	7'-0"	14,157

\* EPOXY COATED REINFORCING STEEL 45,491 LBS.  
CLASS AA CONCRETE 263.4 CU. YDS.  
CONCRETE BARRIER RAIL 1,937.7 LIN. FT.

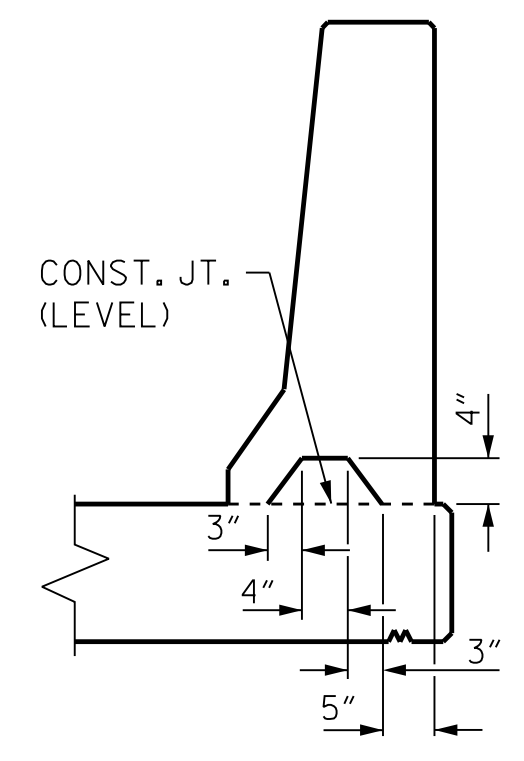

**SECTION S-S**  
AT DAM IN OPEN JOINT  
(THIS IS TO BE USED ONLY WHEN SLIP FORM IS USED)

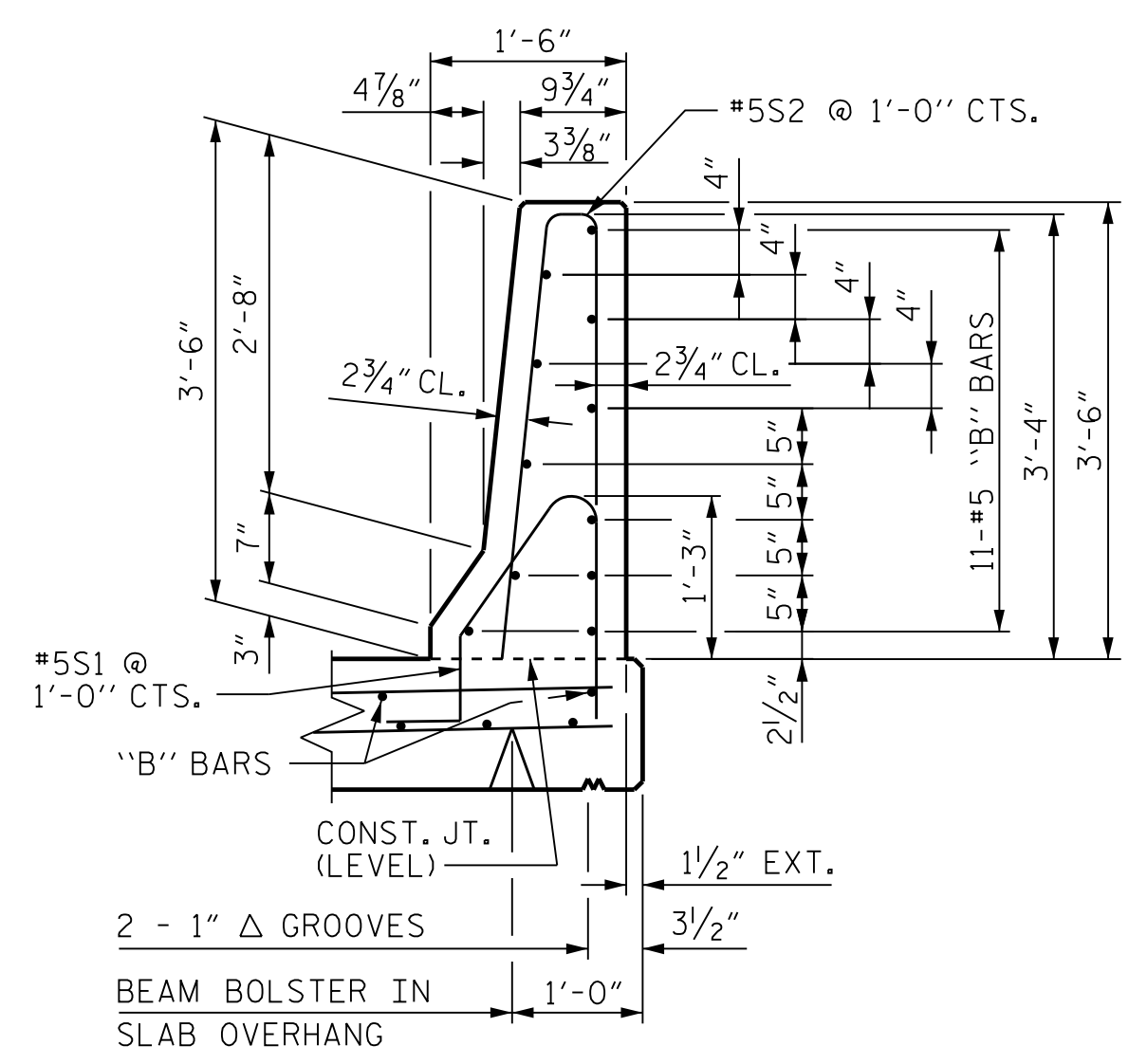

**SECTION THROUGH RAIL**

**BARRIER RAIL DETAILS**

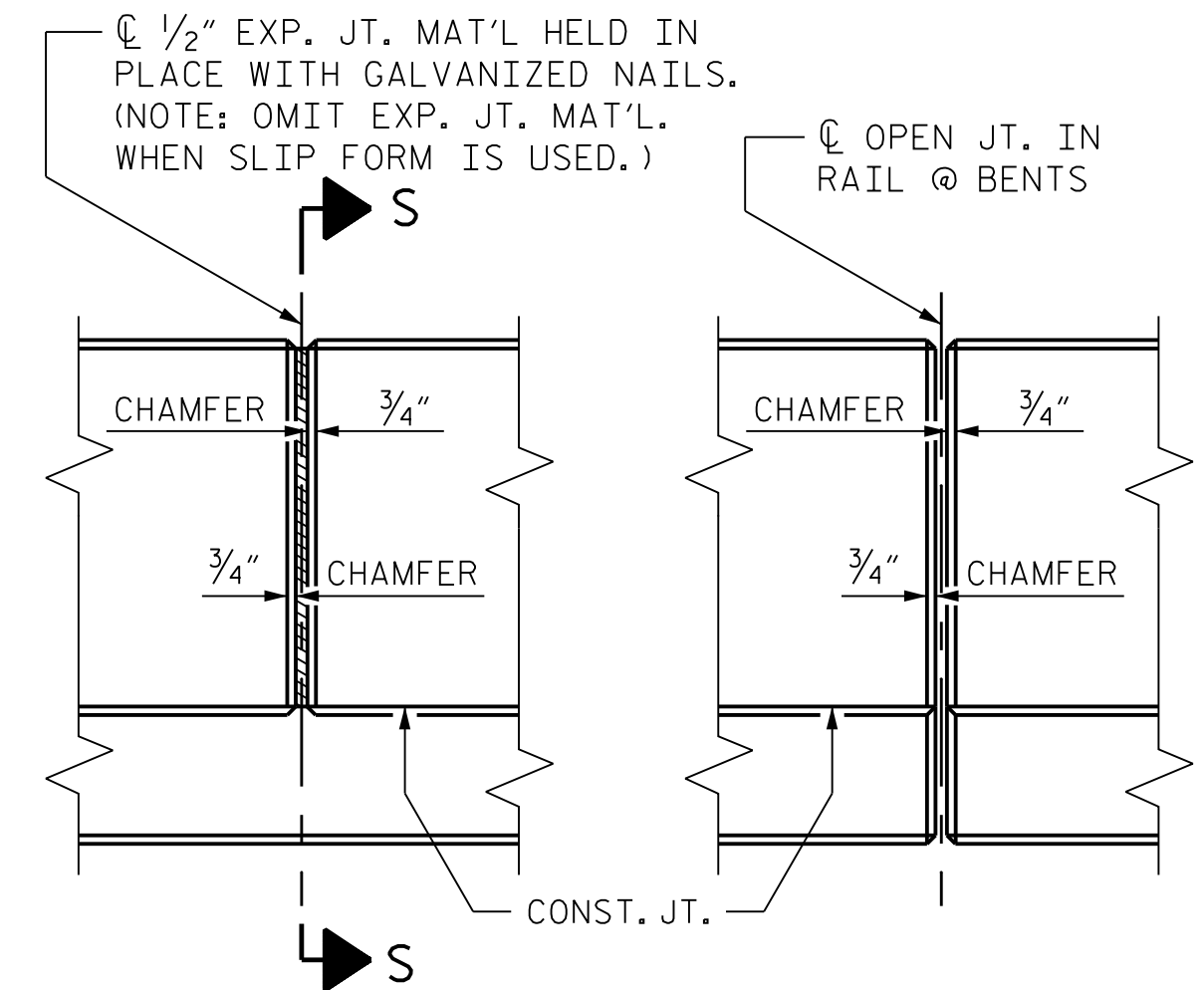

**ELEVATION AT EXPANSION JOINTS**

PROJECT NO. U-2579AB  
FORSYTH COUNTY  
STATION: 60+66.06 -Y15FLYAC-

STATE OF NORTH CAROLINA  
DEPARTMENT OF TRANSPORTATION  
RALEIGH

**SUPERSTRUCTURE  
CONCRETE BARRIER  
RAIL DETAILS**



REVISIONS					
NO.	BY:	DATE:	NO.	BY:	DATE:
1	--	--	3	--	--
2	--	--	4	--	--

SHEET NO. S04-081  
TOTAL SHEETS 144

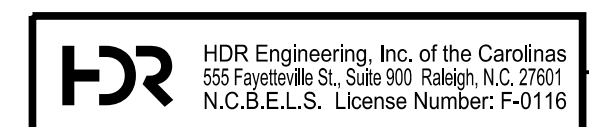

DOCUMENT NOT CONSIDERED FINAL  
UNLESS ALL SIGNATURES COMPLETED

PLOT DRIVER: NCDOT.pdf\_color\_eng-50.ppt  
 USER: PPETERSO  
 DATE: 10/14/2021  
 TIME: 4:03:38 PM  
 FILE: ... \SUPERS

DES BY: <u>L. ZAMPETTI</u>	DATE: <u>07/19</u>	DWG BY: <u>M. SELLS</u>	DATE: <u>07/19</u>
DES CHK: <u>J. ROBERTS</u>	DATE: <u>07/19</u>	CHK BY: <u>S. NIFONG</u>	DATE: <u>11/19</u>

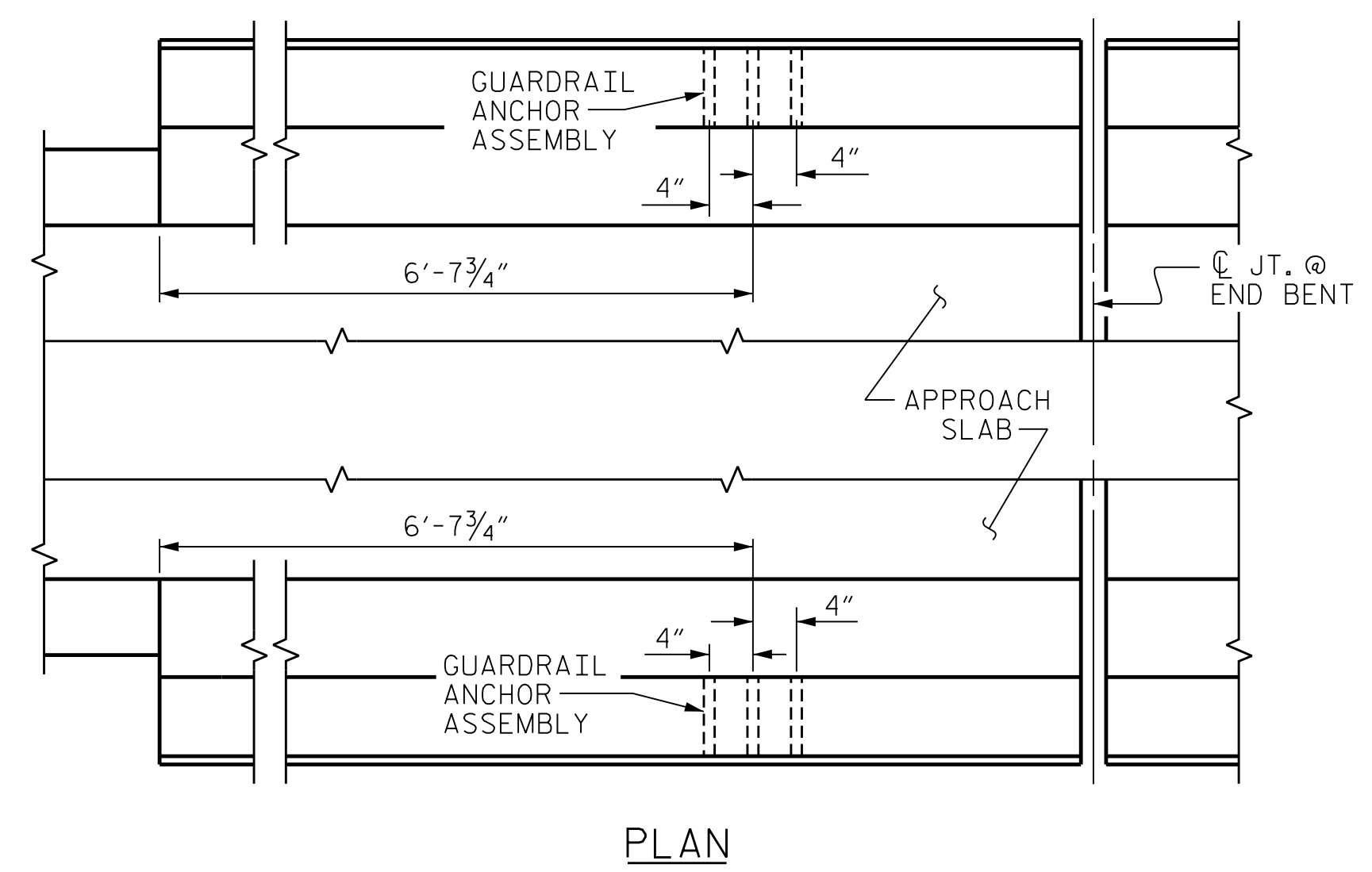
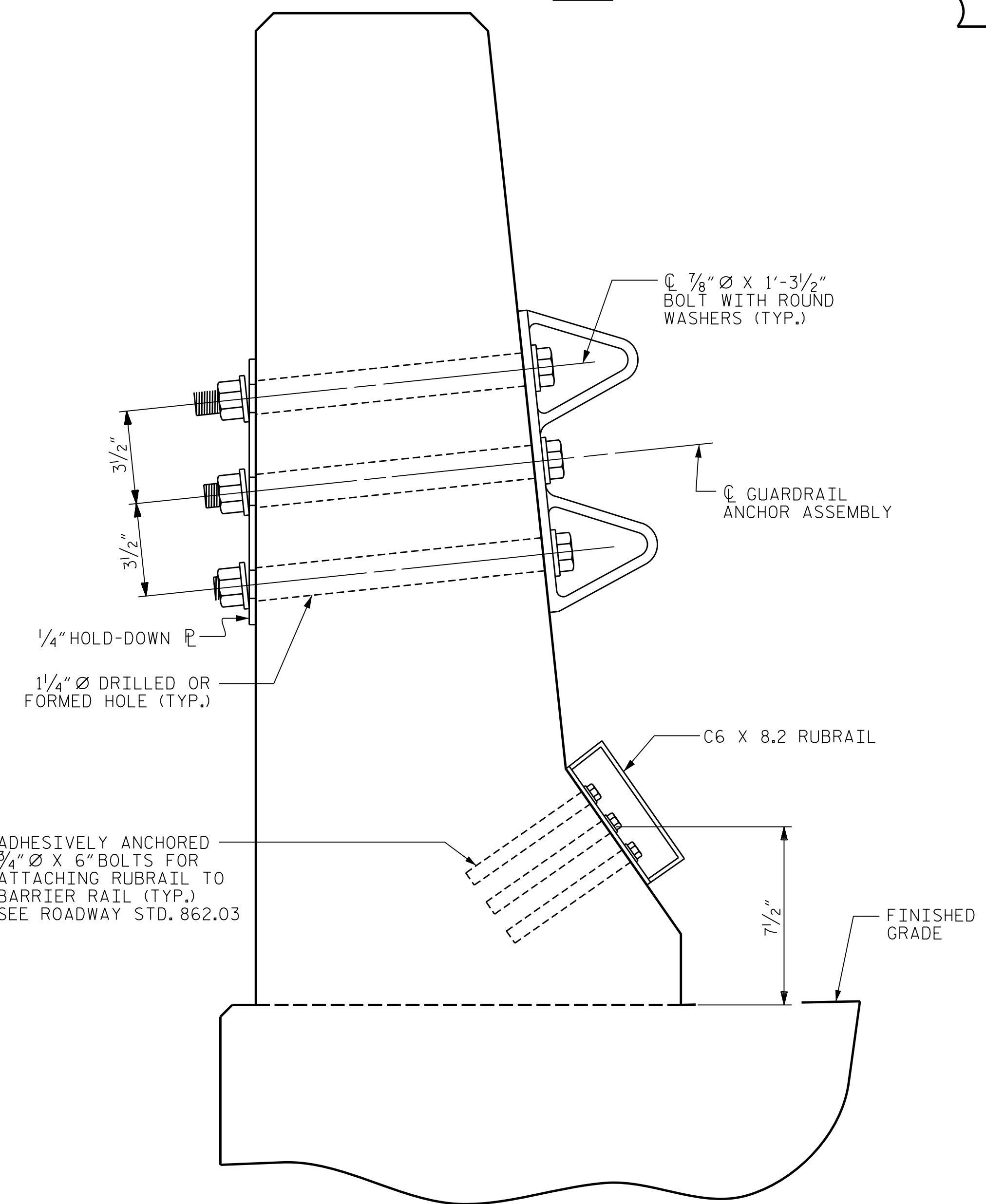
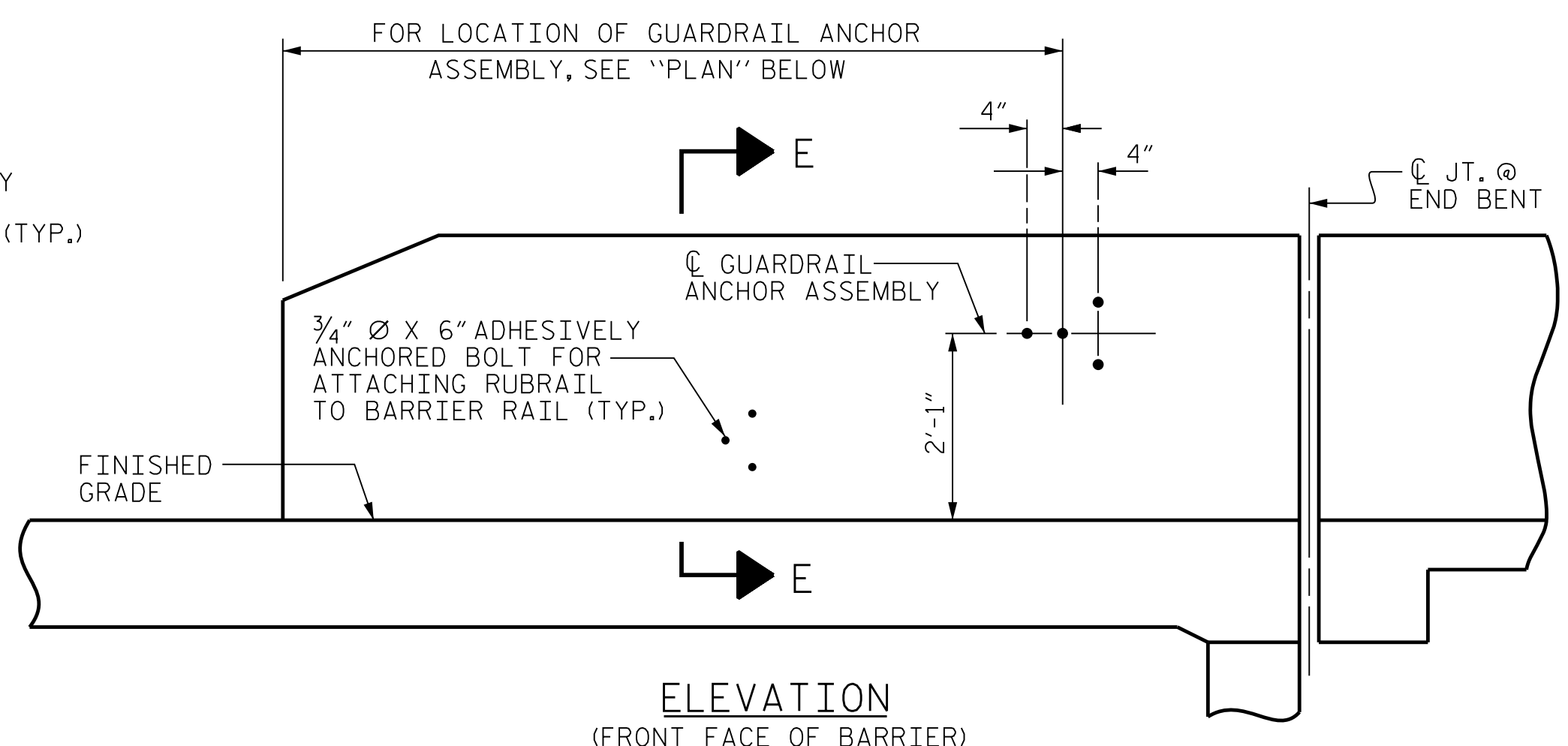
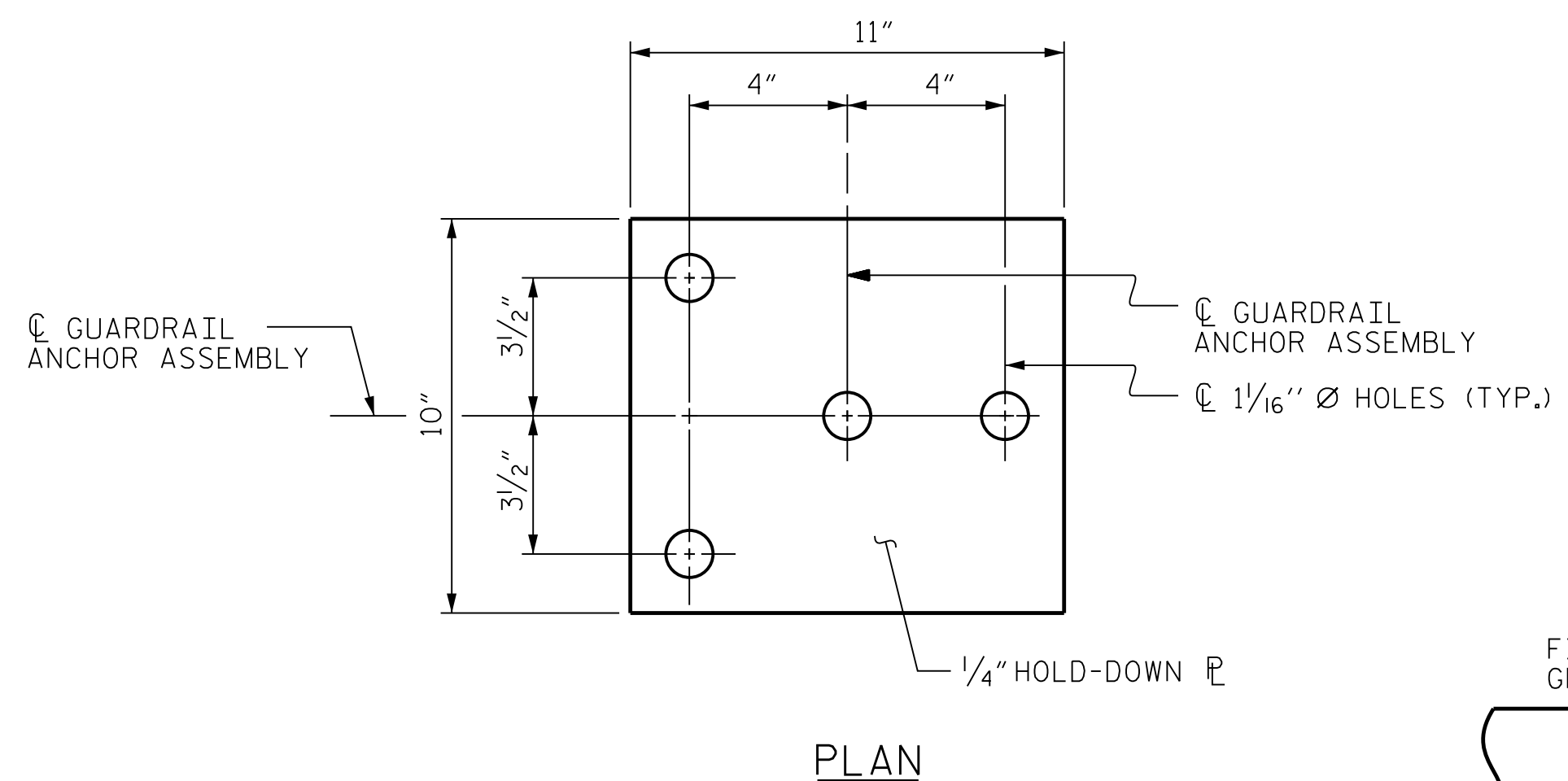

LOCATION OF ANCHORS FOR GUARDRAIL  
END BENT #1 SHOWN, END BENT #2 SIMILAR.

NOTES

THE GUARDRAIL ANCHOR ASSEMBLY SHALL CONSIST OF A 1/4" HOLD-DOWN PLATE AND 4 - 1/8" Ø BOLTS WITH NUTS AND WASHERS, RUBRAIL, AND ADHESIVELY ANCHORED BOLTS.

THE HOLD-DOWN PLATE SHALL CONFORM TO AASHTO M270 GRADE 36. AFTER FABRICATION, THE HOLD-DOWN PLATE SHALL BE HOT-DIP GALVANIZED IN ACCORDANCE WITH AASHTO M111.

BOLTS SHALL CONFORM TO THE REQUIREMENTS OF ASTM A307 AND NUTS SHALL CONFORM TO THE REQUIREMENTS OF AASHTO M291. BOLTS, NUTS AND WASHERS SHALL BE GALVANIZED. (AT THE CONTRACTOR'S OPTION, STAINLESS STEEL BOLTS, NUTS AND WASHERS MAY BE USED AS AN ALTERNATE FOR THE 1/8" Ø GALVANIZED BOLTS, NUTS AND WASHERS. THEY SHALL CONFORM TO OR EXCEED THE MECHANICAL REQUIREMENTS OF ASTM A307. THE USE OF THIS ALTERNATE SHALL BE APPROVED BY THE ENGINEER.)

THE GUARDRAIL ANCHOR ASSEMBLY IS REQUIRED AT ALL POINTS WHERE APPROACH GUARDRAIL IS TO BE ATTACHED TO THE END OF BARRIER RAIL. FOR POINTS OF ATTACHMENT, SEE SKETCH.

AFTER INSTALLATION, THE EXPOSED THREAD OF THE BOLT SHALL BE BURRED WITH A SHARP POINTED TOOL.

THE COST OF THE GUARDRAIL ANCHOR ASSEMBLY SHALL BE INCLUDED IN THE UNIT CONTRACT PRICE BID FOR CONCRETE BARRIER RAIL.

THE 1/4" Ø HOLES SHALL BE FORMED OR DRILLED WITH A CORE BIT. IMPACT TOOLS WILL NOT BE PERMITTED. ANY CONCRETE DAMAGED BY THIS WORK SHALL BE REPAIRED TO THE SATISFACTION OF THE ENGINEER.

THE C6 X 8.2 RUBRAIL IS TO BE ADHESIVELY ANCHORED TO THE RAIL USING THREE 3/4" Ø X 6" BOLTS WITH WASHERS. LEVEL ONE FIELD TESTING IS REQUIRED, AND THE YIELD LOAD OF THE 3/4" Ø BOLT IS 12 KIPS. FOR ADHESIVELY ANCHORED ANCHOR BOLTS OR DOWELS, SEE STANDARD SPECIFICATIONS. SEE ROADWAY STANDARD 862.03 FOR DETAILS AND LOCATION OF THE RUBRAIL.

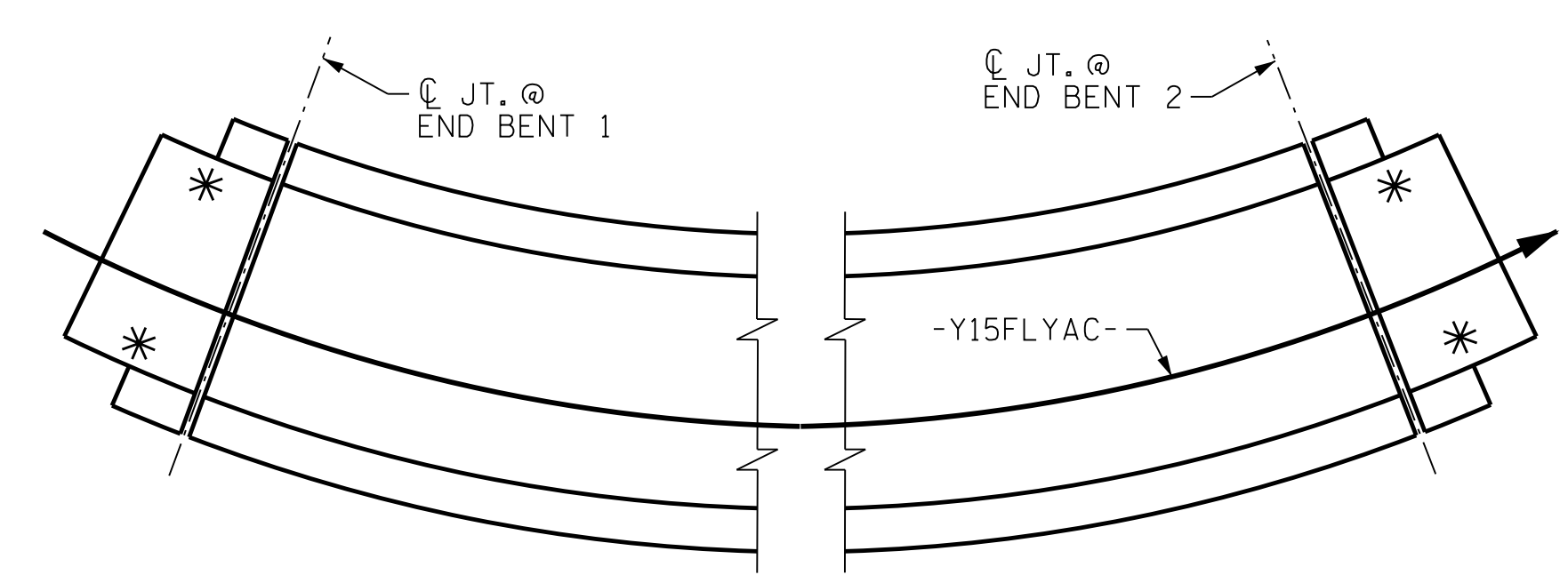

SKETCH SHOWING POINTS OF ATTACHMENTS  
\* = DENOTES GUARDRAIL ANCHOR ASSEMBLY

PROJECT NO. U-2579AB  
FORSYTH COUNTY  
STATION: 60+66.06 -Y15FLYAC-



STATE OF NORTH CAROLINA  
DEPARTMENT OF TRANSPORTATION  
RALEIGH  
STANDARD  
GUARDRAIL ANCHORAGE  
FOR BARRIER RAIL

ASSEMBLED BY : M. SELLS	DATE : 07/19
CHECKED BY : S. NIFONG	DATE : 11/19
DRAWN BY : TLA 5/06	REV. 7/12 MAA/GM
CHECKED BY : GM 5/06	REV. 6/13 MAA/GM
	REV. 12/17 MAA/THC

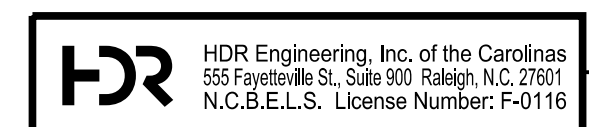

REVISIONS

NO.	BY:	DATE:	NO.	BY:	DATE:
1	--	--	3	--	--
2	--	--	4	--	--

DOCUMENT NOT CONSIDERED FINAL  
UNLESS ALL SIGNATURES COMPLETED

SHEET NO. S04-082
TOTAL SHEETS 144

PLOT DRIVER: NCDOT\_pdf\_color\_eng-50dpi  
 USER: PPEIERSO DATE: 10/14/2021  
 FILE: ... \SUPERS

+

+

**INSTALLATION PROCEDURE**

1. A TEMPLATE OR OTHER SUITABLE DEVICE SHALL BE USED TO FORM THE TOP OF THE EXPANSION JOINT SEAL BLOCKOUT TO THE PROPER DEPTH AND WIDTH. THE TEMPLATE SHALL BE 4/8" TO 4/4" WIDE AND OF SUCH THICKNESS AS TO PROVIDE FOR CORRECT FINAL ELEVATION OF TOP OF HOLD-DOWN PLATES. THE TEMPLATE SHALL BE ATTACHED TO THE BASE ANGLE ASSEMBLY WITH THE 3/4" Ø HEX HEAD BOLTS PROVIDED FOR THE HOLD-DOWN PLATES. A 1" Ø HOLE SHALL BE PROVIDED IN THE TEMPLATE CENTERED OVER EACH WEEP HOLE IN THE 4" X 4" X 1/2" BASE ANGLE. OTHER METHODS OF ENSURING DRAINAGE THROUGH WEEP HOLES MAY BE EMPLOYED SUBJECT TO ENGINEER'S APPROVAL.
2. AFTER THE CONCRETE HAS BEEN CAST ON BOTH SIDES OF THE JOINT, REMOVE THE TEMPLATE. THOROUGHLY CLEAN THE BOLT HOLES AND THE ANGLE PLATE. REMOVE ANY EXCESS CONCRETE THAT COMES OUT OF THE WEEP HOLES. ANY DAMAGED STEEL SHALL BE REPAIRED IN ACCORDANCE WITH THE SPECIAL PROVISION FOR THERMAL SPRAYED COATINGS (METALLIZATION).
3. LAY THE GLAND ON THE BASE ANGLE AND FIELD MARK THE GLAND FOR THE BOLT HOLES. HOLES IN THE GLAND SHALL BE PUNCHED 7/8" IN DIAMETER WITH A HAND PUNCH.
4. IN ORDER TO CHECK FOR PROPER ALIGNMENT, PLACE THE GLAND AND HOLD-DOWN PLATES ON THE BASE ANGLE. DO NOT APPLY NEOPRENE SEALANT. BOLT THE HOLD-DOWN PLATES TO THE BASE ANGLE BUT DO NOT TIGHTEN. THE ENGINEER SHALL INSPECT THE JOINT SEAL DEVICE FOR PROPER ALIGNMENT.
5. AFTER INSPECTION, REMOVE THE HOLD-DOWN PLATES AND GLAND. APPLY NEOPRENE SEALANT TO THE BASE ANGLE IN ACCORDANCE WITH THE "INSTALLATION SKETCH". PLACE GLAND AND HOLD-DOWN PLATES ON THE BASE ANGLE. BOLT THE HOLD-DOWN PLATES TO THE BASE ANGLE ASSEMBLY AND TORQUE THE BOLTS TO 88 FT-LBS WITH A TORQUE WRENCH. CHECK THE TORQUE AFTER THREE (3) HOURS AND, IF NECESSARY, RETIGHTEN TO 88 FT-LBS. A FINAL CHECK SHALL BE MADE AT SEVEN (7) DAYS. TORQUE SHALL NOT BE LESS THAN 80 FT-LBS AFTER SEVEN (7) DAYS.
6. AFTER PROPER TORQUING, CLEAN THE BOLT HOLE RECESSES AND THE RECESS BETWEEN THE JOINT SEAL DEVICE AND CONCRETE, AND THE LIFTING HOLES IN THE HOLD-DOWN PLATE, AND COMPLETELY FILL THE RECESSES AND LIFTING HOLES WITH NEOPRENE SEALANT.

**GENERAL NOTES**

1. FOR EXPANSION JOINT SEALS, SEE SPECIAL PROVISIONS.
2. ALL PLATES AND ANGLES SHALL CONFORM TO AASHTO M270 GRADE 36 STEEL OR APPROVED EQUAL. ALL HOLD-DOWN BOLTS SHALL CONFORM TO ASTM F593 ALLOY 304 STAINLESS STEEL AND WASHERS SHALL CONFORM TO ASTM F844 EXCEPT THEY SHALL BE MADE FROM ALLOY 304 STAINLESS STEEL. ALL STUD ANCHORS SHALL CONFORM TO AASHTO M169, GRADES 1010 THRU 1020 OR APPROVED EQUAL. ALL CONCRETE INSERTS SHALL BE CLOSED END AND SHALL CONFORM TO AASHTO M169, GRADE 12L14. TENSILE CAPACITY SHALL BE 3000 LBS. MINIMUM.
3. A PREMOLDED CORRUGATED OR NON-CORRUGATED GLAND SHALL BE USED FOR JOINTS SKEWED BETWEEN 50° THRU 130°. FOR JOINTS SKEWED LESS THAN 50° OR MORE THAN 130°, ONLY A CORRUGATED GLAND SHALL BE USED.
4. CLOSED END FERRULES AND STUD ANCHORS SHALL BE SHOP WELDED AND ALL HOLES SHALL BE SHOP DRILLED AS SHOWN ON PLANS. STUD ANCHORS SHALL BE ELECTRIC ARC END WELDED WITH COMPLETE FUSION.
5. SURFACES COMING IN CONTACT WITH NEOPRENE SHALL BE GROUND SMOOTH PRIOR TO METALLIZING.
6. UPON COMPLETION OF SHOP FABRICATION, THE HOLD DOWN PLATE AND BASE ANGLE ASSEMBLY, AS SHOWN IN THE "TYPICAL SECTION OF BASE ANGLE ASSEMBLY", SHALL BE METALLIZED IN ACCORDANCE WITH THE STANDARD SPECIFICATIONS FOR THERMAL SPRAYED COATINGS (METALLIZATION), SEE SPECIAL PROVISIONS.
7. THE COVER PLATES SHALL BE GALVANIZED OR METALLIZED IN ACCORDANCE WITH THE STANDARD SPECIFICATIONS FOR THERMAL SPRAYED COATINGS (METALLIZATION), SEE SPECIAL PROVISIONS.
8. BASE ANGLE ASSEMBLY SHALL BE CONTINUOUS FOR THE LENGTH OF THE JOINT. AT CROWN BREAKS, THE ENDS OF THE BASE ANGLE ASSEMBLY SHALL BE CUT PARALLEL TO THE BRIDGE CENTERLINE FOR SKEWS LESS THAN 80° AND GREATER THAN 100°. FINISHED WELD SHALL BE REPAIRED IN ACCORDANCE WITH THE SPECIAL PROVISION FOR THERMAL SPRAYED COATINGS (METALLIZATION).
9. FIELD SPLICES OF HOLD-DOWN PLATES SHALL BE KEPT TO A MINIMUM. CONTRACTOR SHALL FURNISH DETAILED PLANS SHOWING PROPOSED SPLICE LOCATIONS FOR APPROVAL. HOLD-DOWN PLATES SHALL NOT EXCEED 20' LENGTHS UNLESS APPROVED BY THE ENGINEER.
10. NO ALTERNATE JOINT DETAILS SHALL BE PERMITTED IN LIEU OF THOSE SHOWN ON THESE PLANS.
11. THE CONTRACTOR MAY, AT HIS OPTION, USE ADHESIVELY ANCHORED ANCHOR BOLTS IN PLACE OF CONCRETE INSERTS FOR COVER PLATES. THE YIELD LOAD OF THE 3/4" Ø BOLT IS 10 KIPS. FIELD TESTING OF THE ADHESIVE BONDING SYSTEM IS NOT REQUIRED.
12. THE FABRICATOR SHALL PROVIDE 1/2" Ø THREADED HOLES IN THE HOLD-DOWN PLATES TO ASSIST IN LIFTING AND PLACING. THE HOLES SHALL BE 3/4" DEEP AT 6'-0" MAXIMUM SPACING AND A MINIMUM OF TWO HOLES PER PLATE.

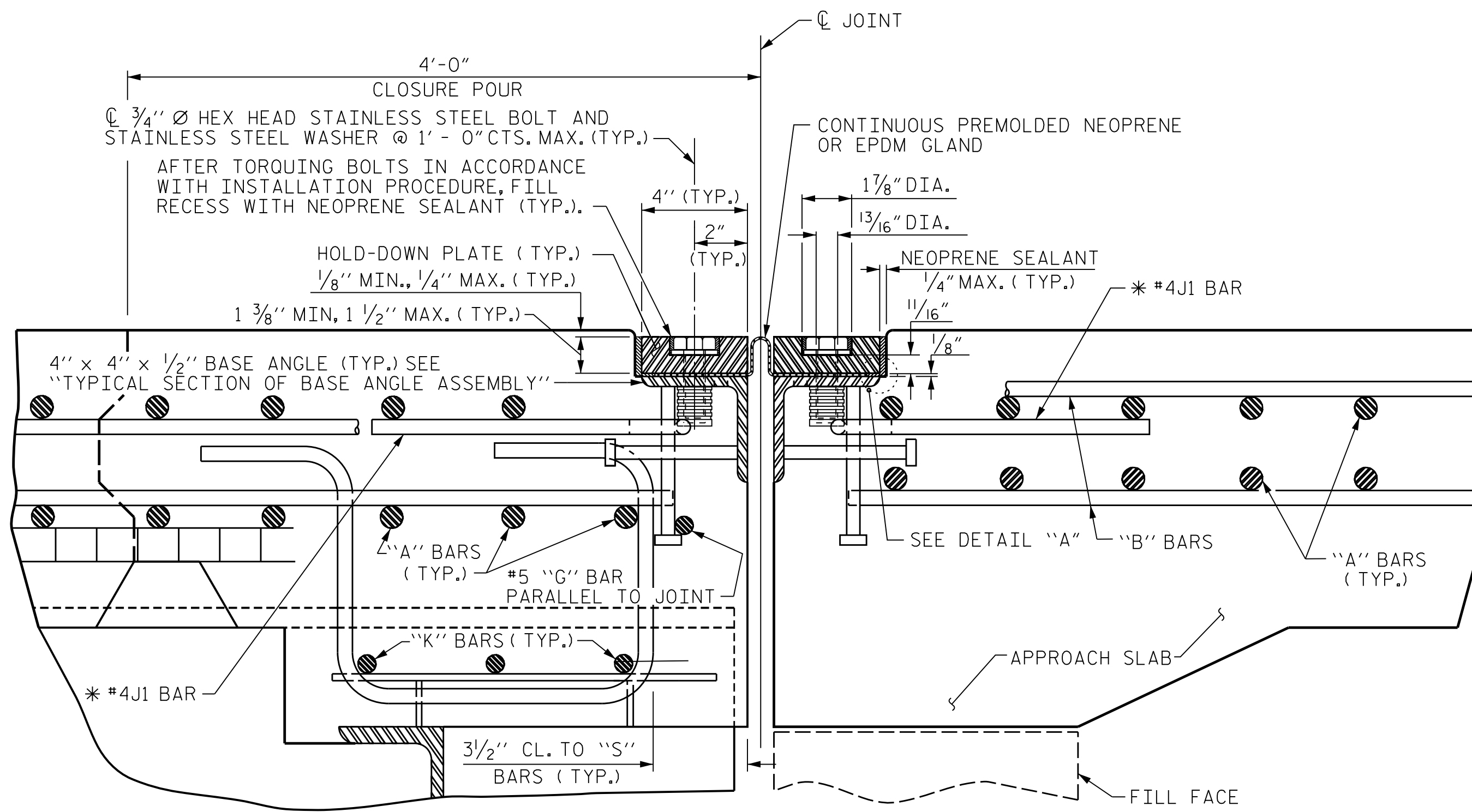

**EXPANSION JOINT DETAILS**

SECTION NORMAL TO JOINT -- STEEL SUPERSTRUCTURE

\* = THE QUANTITY OF #4J1 BARS ON THE BILL OF MATERIAL IS BASED ON 1'-0" CENTERS. J1 BARS SHALL BE PLACED AT EACH VERTICAL STUD ANCHOR BOLT. IN THE EVENT THAT THE NUMBER OF VERTICAL STUD ANCHORS EXCEEDS THE NUMBER OF J1 BARS SPECIFIED, ADDITIONAL J1 BARS WILL NOT BE REQUIRED.

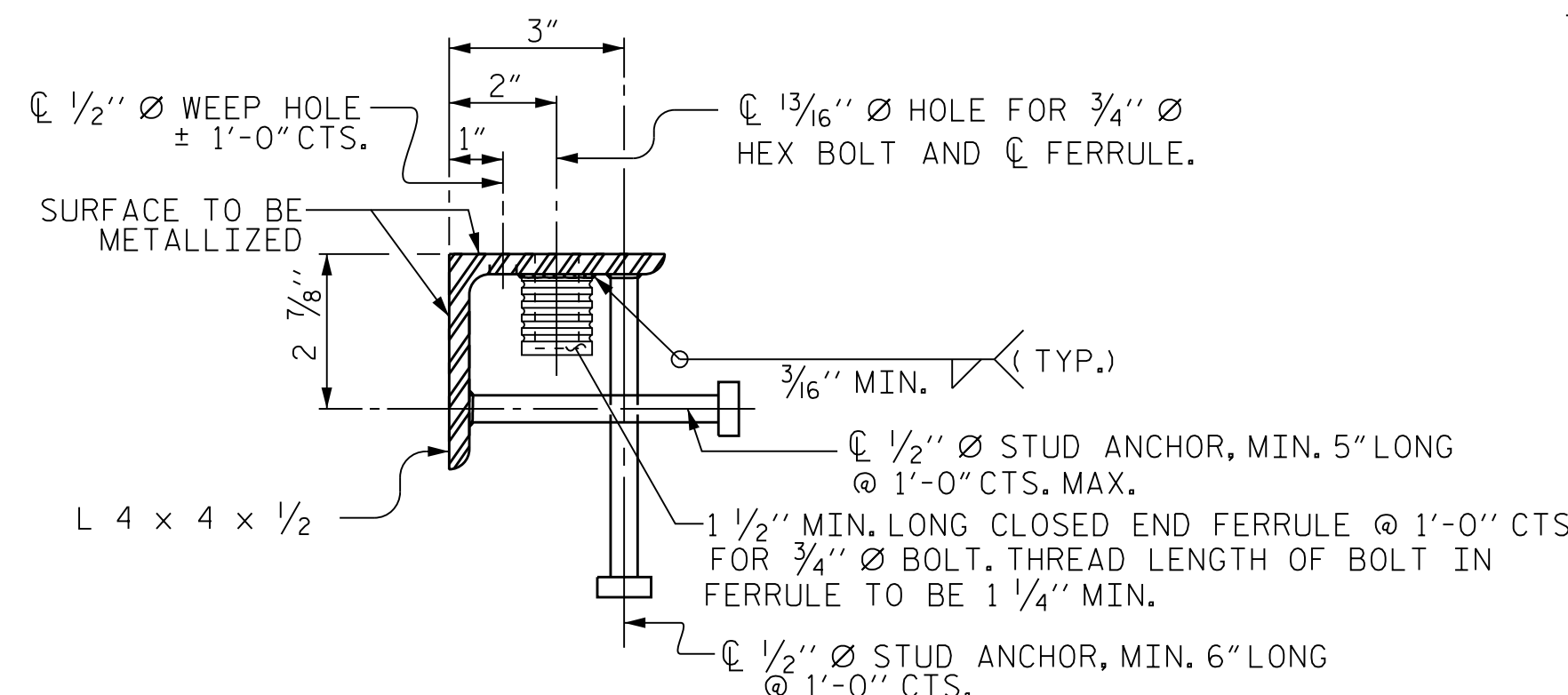
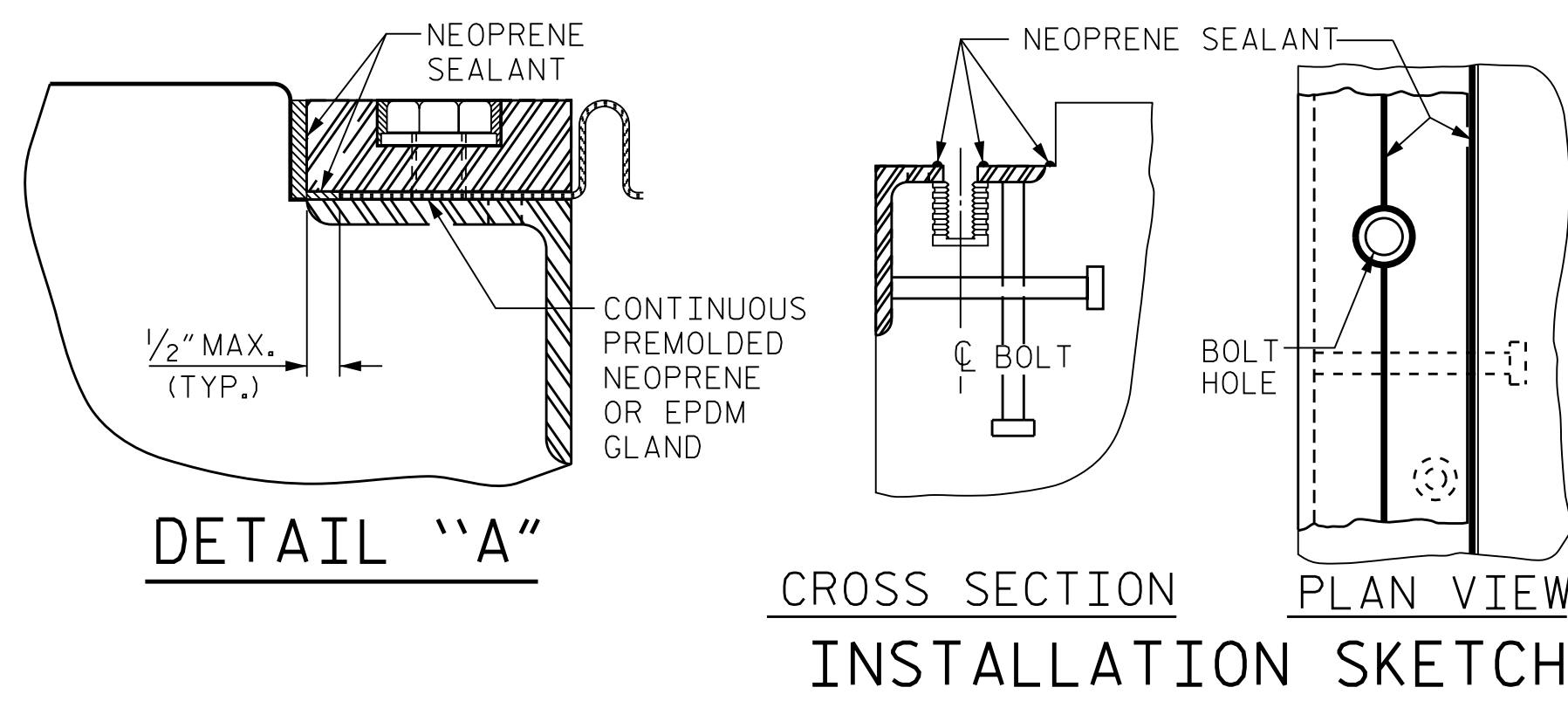

**TYPICAL SECTION OF BASE ANGLE ASSEMBLY**

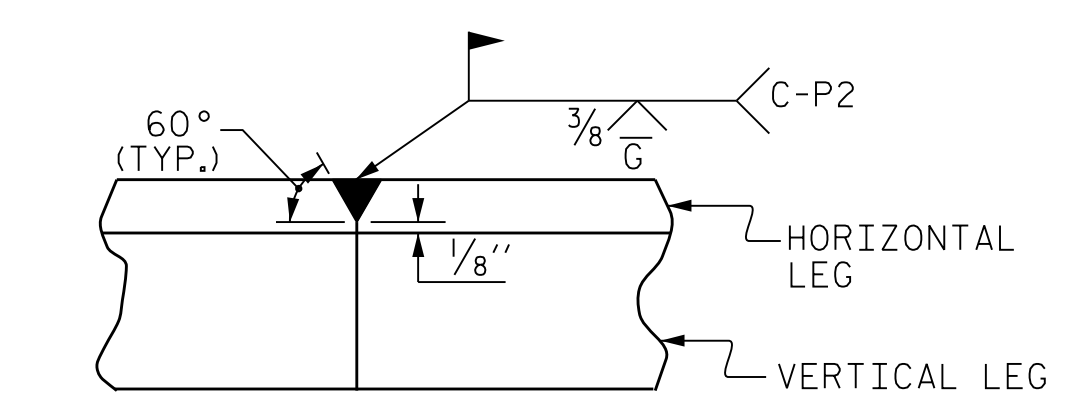

**DETAIL - FIELD WELD SPLICE OF BASE ANGLE**

MOVEMENT AND SETTING AT JOINT					
LOCATION	SKEW ANGLE	TOTAL MOVEMENT (ALONG CL RDWY)	PERPENDICULAR JOINT OPENING AT 45° F	PERPENDICULAR JOINT OPENING AT 60° F	PERPENDICULAR JOINT OPENING AT 90° F
END BENT #2	90°00'00"	1 13/16"	2 3/16"	1 7/8"	1 3/8"

PROJECT NO. U-2579AB  
FORSYTH COUNTY  
 STATION: 60+66.06 -Y15FLYAC-

STATE OF NORTH CAROLINA  
 DEPARTMENT OF TRANSPORTATION  
 RALEIGH  
 STANDARD  
**EXPANSION JOINT SEAL DETAILS**

REVISIONS						SHEET NO. S04-083 TOTAL SHEETS 144
NO.	BY:	DATE:	NO.	BY:	DATE:	
1	--	--	3	--	--	
2	--	--	4	--	--	



10/15/2021

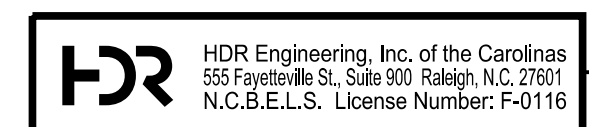

DOCUMENT NOT CONSIDERED FINAL UNLESS ALL SIGNATURES COMPLETED

PLOT DRIVER: NCDOT.pdf\_color\_eng-50dpi  
 USER: PPEIERSO  
 FILE: ... \SUPERS  
 PENTABLE: NCDOT STRUCTURES DEFAULT PEN.tbl  
 TIME: 4:03:52 PM  
 DATE: 10/14/2021

ASSEMBLED BY : T. SAS	DATE : 10/19
CHECKED BY : T. ANDREWS	DATE : 11/19
DRAWN BY : REK 9/87	REV. 10/1/11 MAA/GM
CHECKED BY : CRK 10/87	REV. 10/17 MAA/THC
	REV. 6/18 MAA/THC

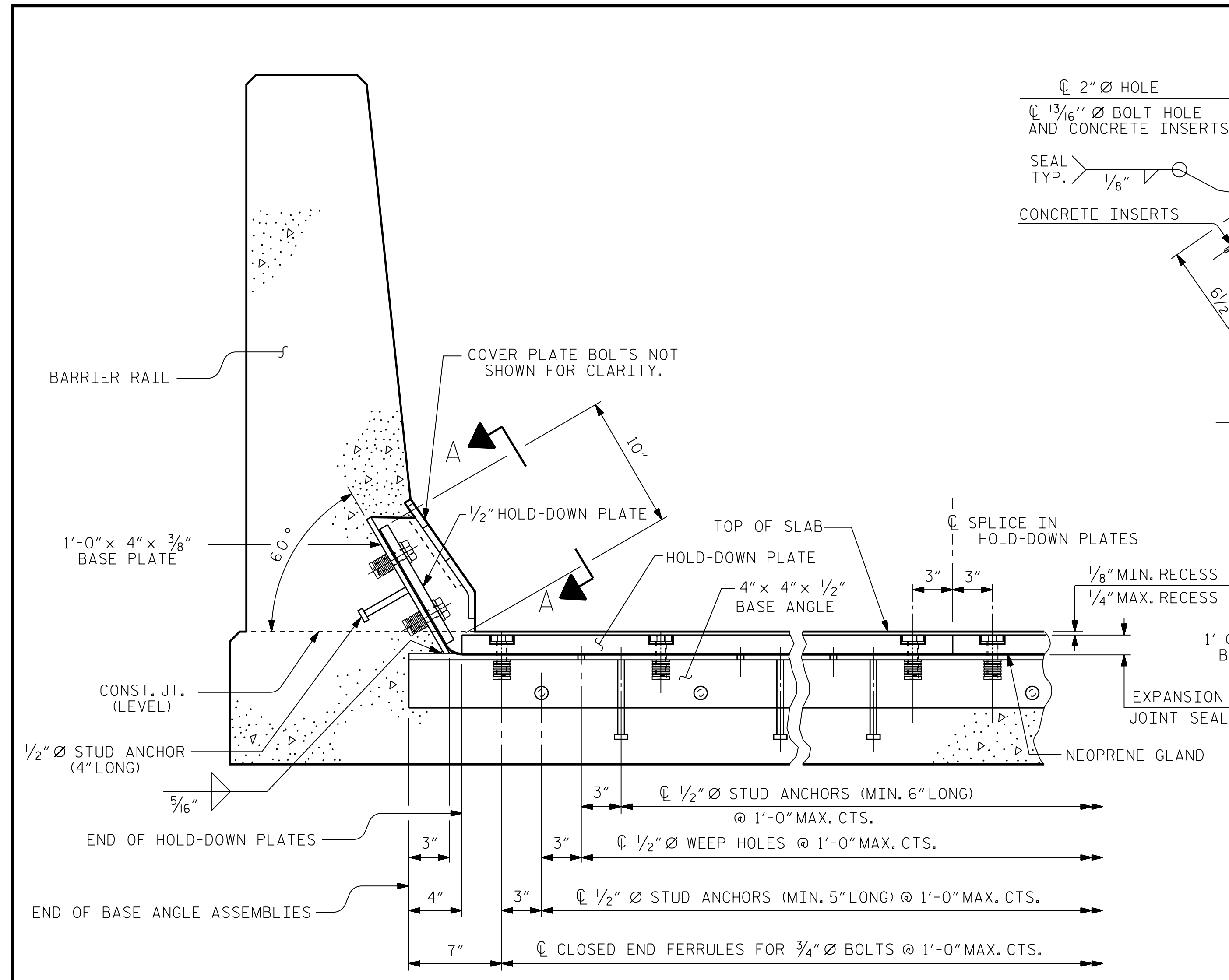

**SECTION THRU RAIL NORMAL TO JOINT**

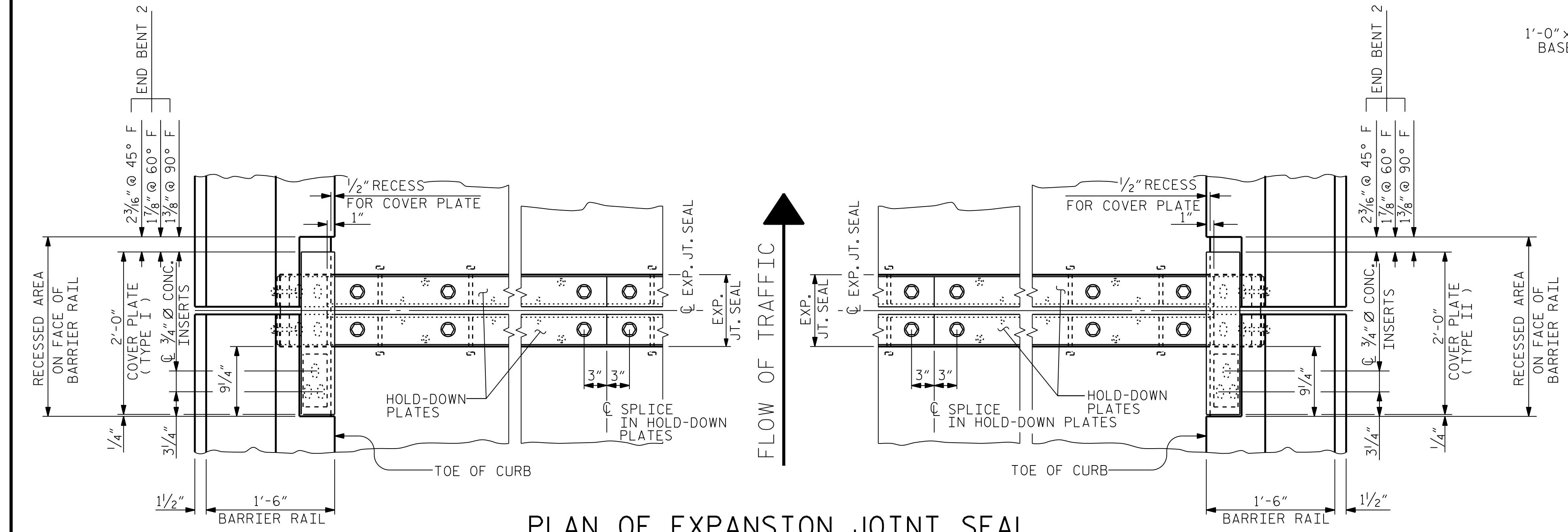

**PLAN OF EXPANSION JOINT SEAL**

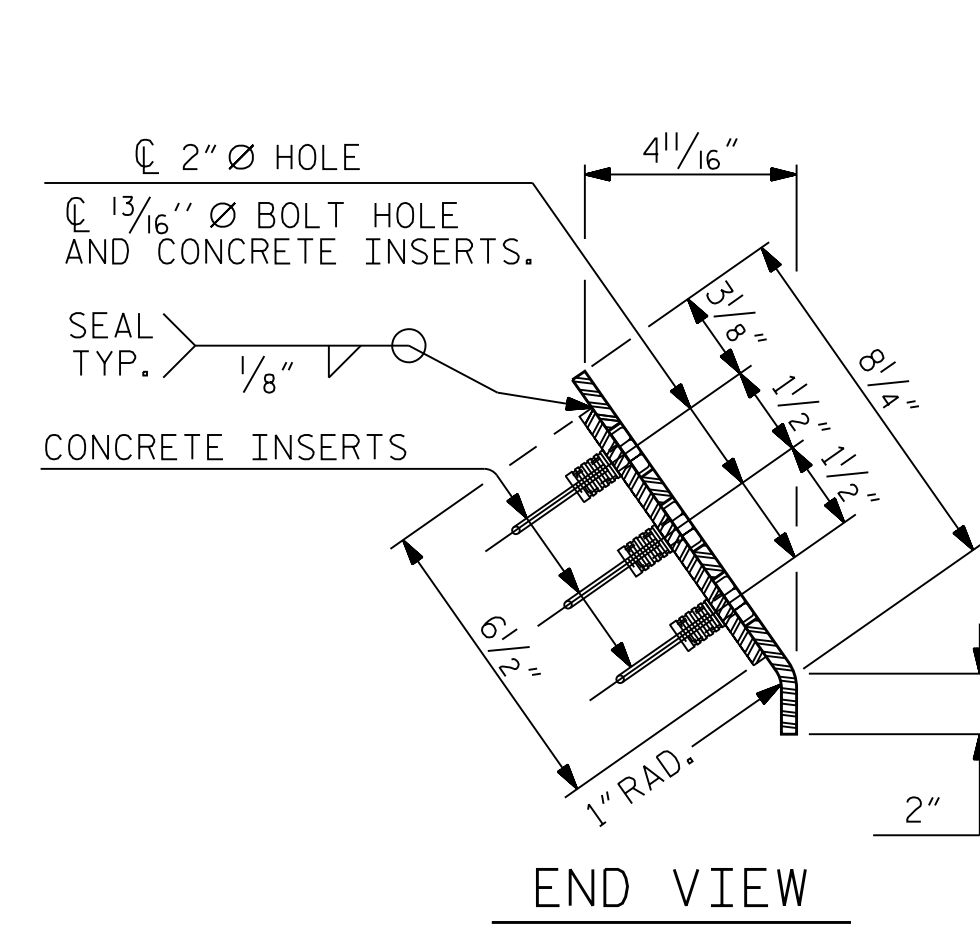

**END VIEW**

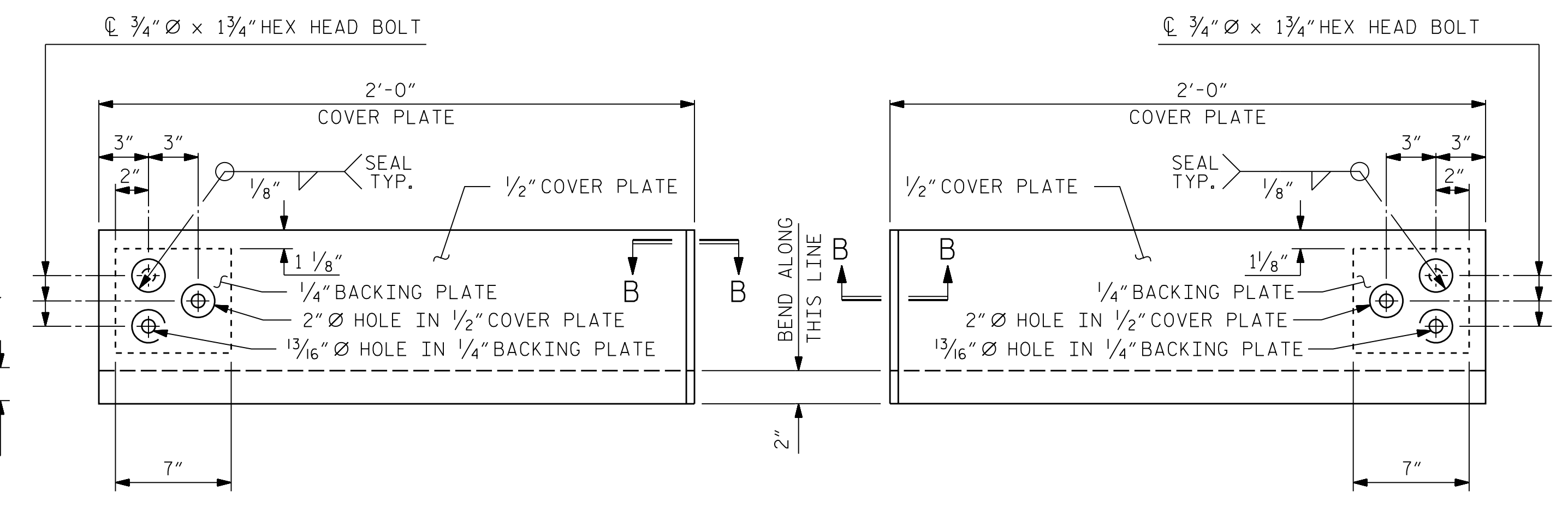

**TYPE I - ELEVATION VIEW**      **TYPE II - ELEVATION VIEW**

**COVER PLATE DETAILS**

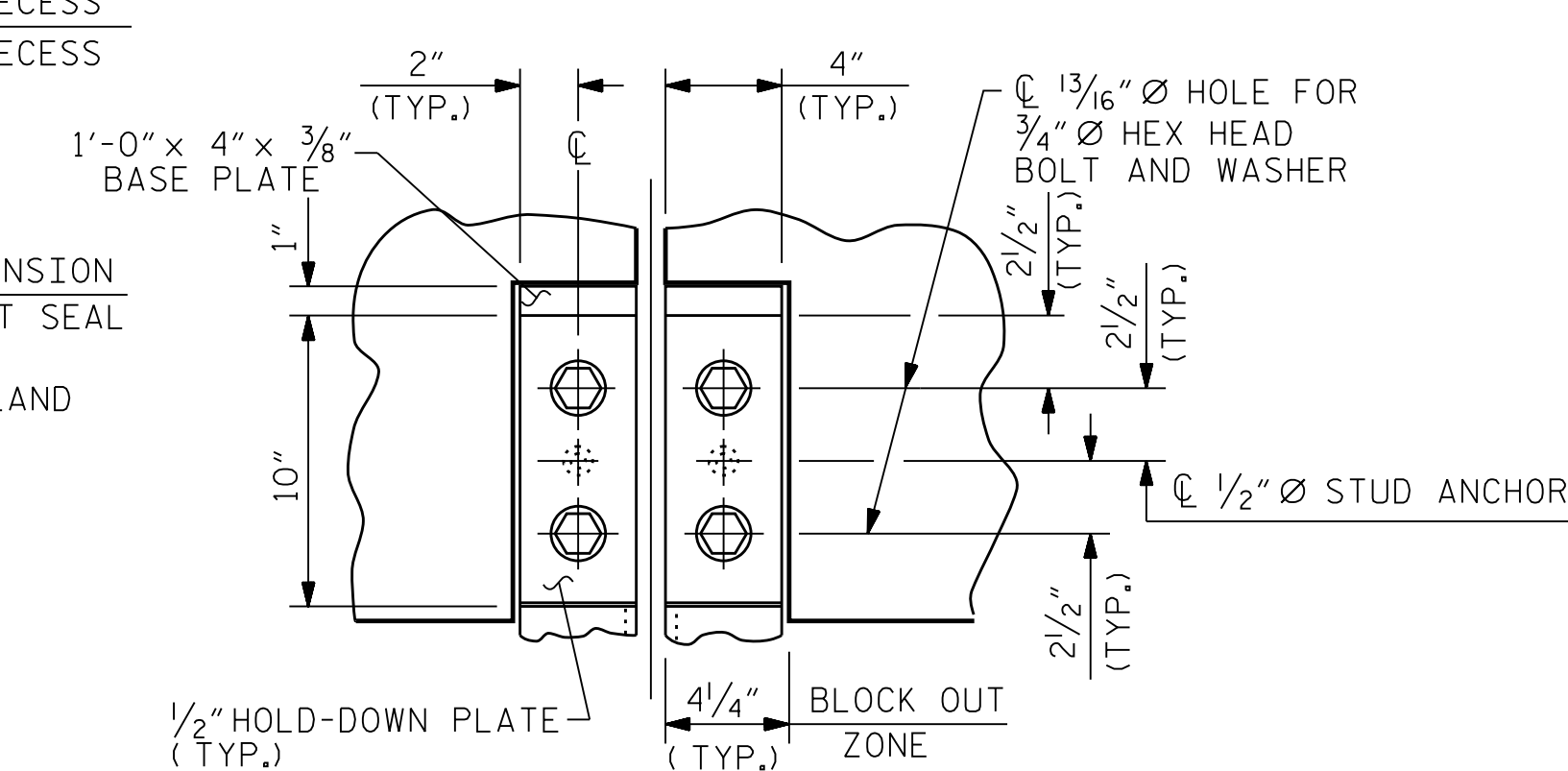

**SECTION A-A**

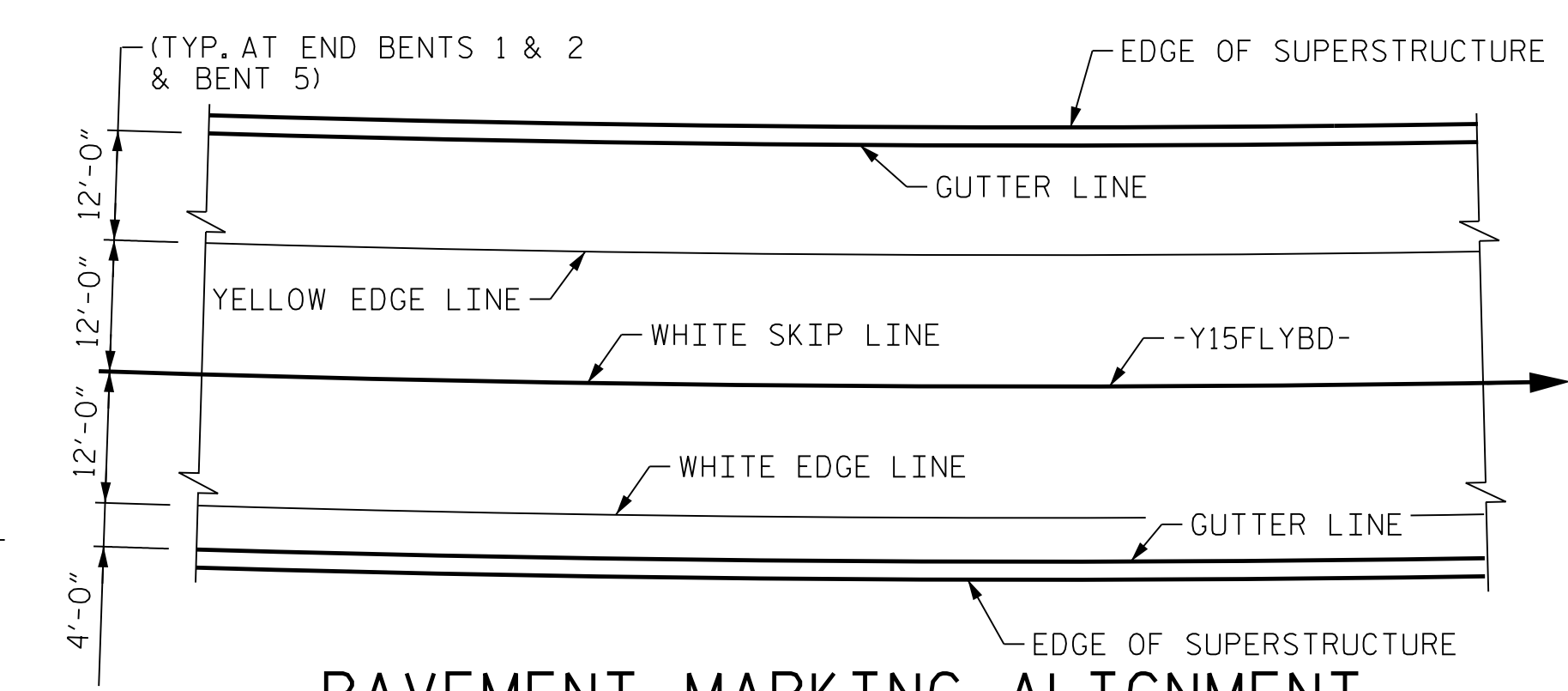

**PAVEMENT MARKING ALIGNMENT**

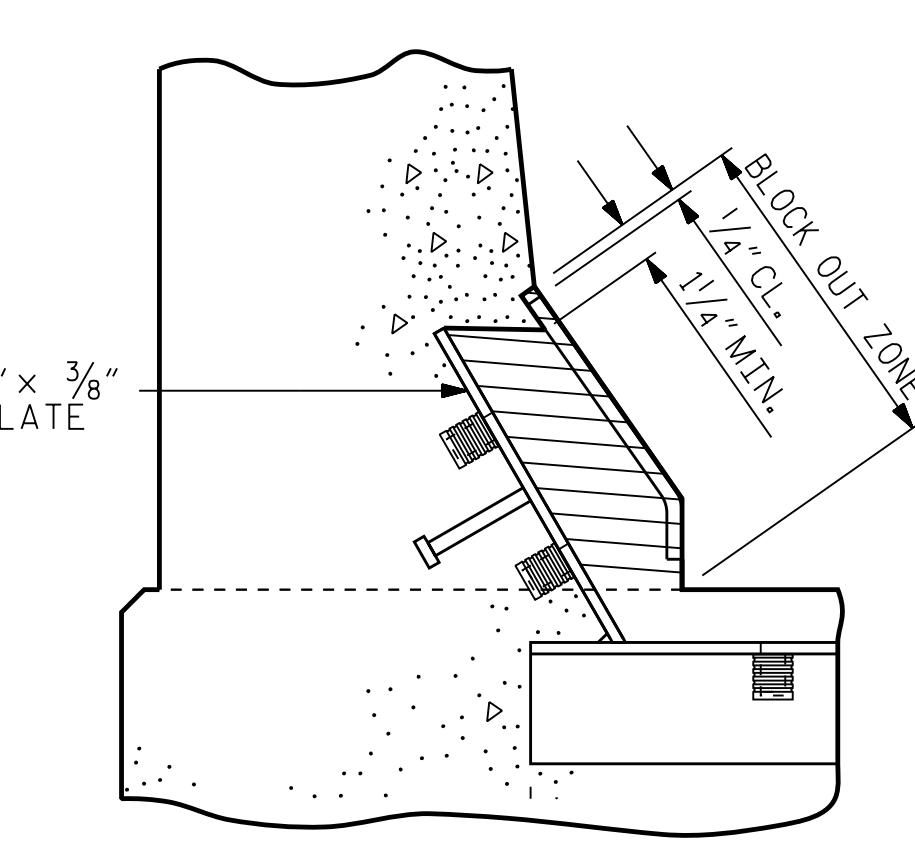

**BLOCK OUT DETAIL**

SEE "SECTION A - A" FOR OTHER DETAILS.

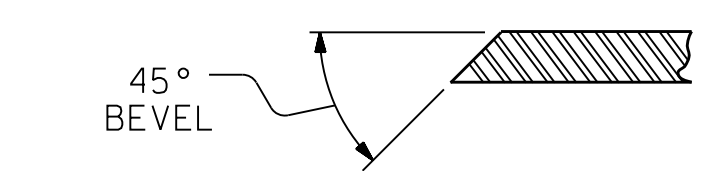

**SECTION B - B**

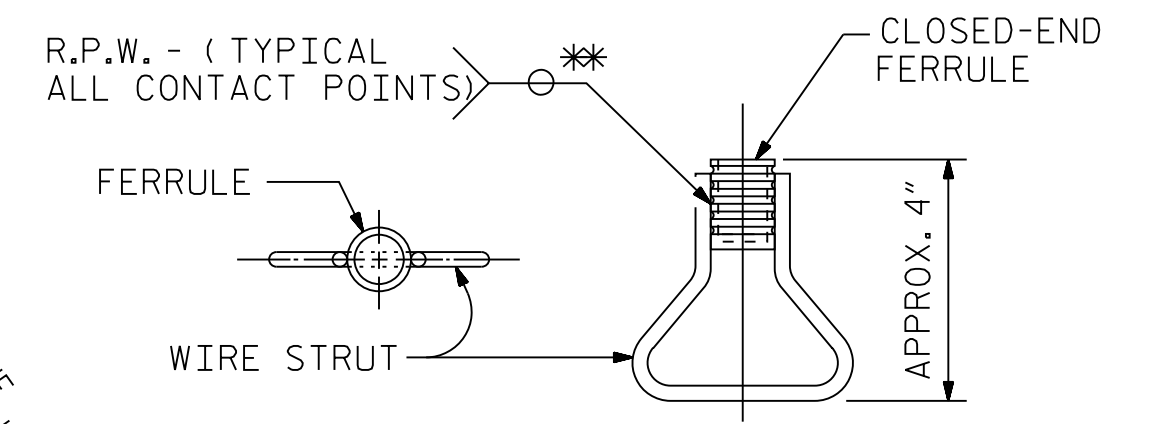

**CONCRETE INSERT**

\*\* = EACH WELDED ATTACHMENT OF WIRE TO FERRULE SHALL DEVELOP THE TENSILE STRENGTH OF THE WIRE.

PROJECT NO. U-2579AB  
 FORSYTH COUNTY  
 STATION: 60+66.06 -Y15FLYAC-



10/15/2021

ASSEMBLED BY : T. SAS	DATE : 10/19
CHECKED BY : T. ANDREWS	DATE : 11/19
DRAWN BY : REK 9/87	REV. 7/12 MAA/GM
CHECKED BY : CRK 10/87	REV. 6/13 MAA/GM
	REV. 12/17 MAA/THC

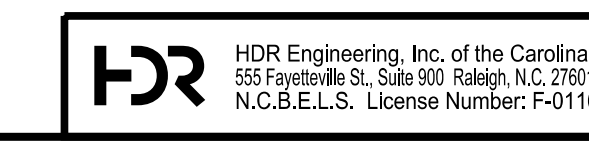

DOCUMENT NOT CONSIDERED FINAL UNLESS ALL SIGNATURES COMPLETED

REVISIONS						SHEET NO. 504-084
NO.	BY:	DATE:	NO.	BY:	DATE:	
1	--	--	3	--	--	TOTAL SHEETS 144
2	--	--	4	--	--	

PENTABLE: NCDOT\_STRUCTURES\_DEFAULT\_PEN.tbl  
 USER: PPRETOSO  
 DATE: 10/14/2021  
 TIME: 4:04:12 PM  
 FILE: ... \SUPERS



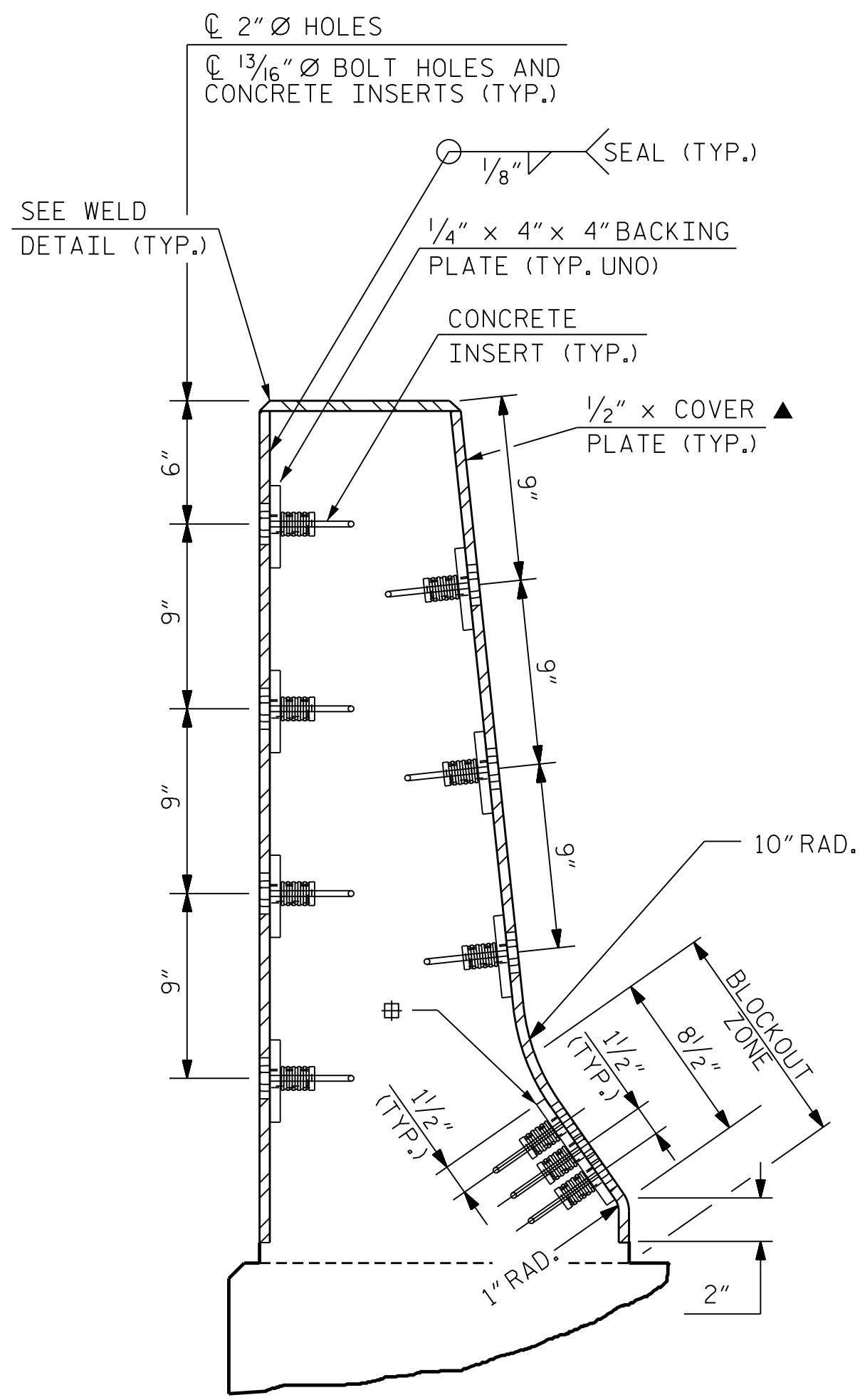

END VIEW

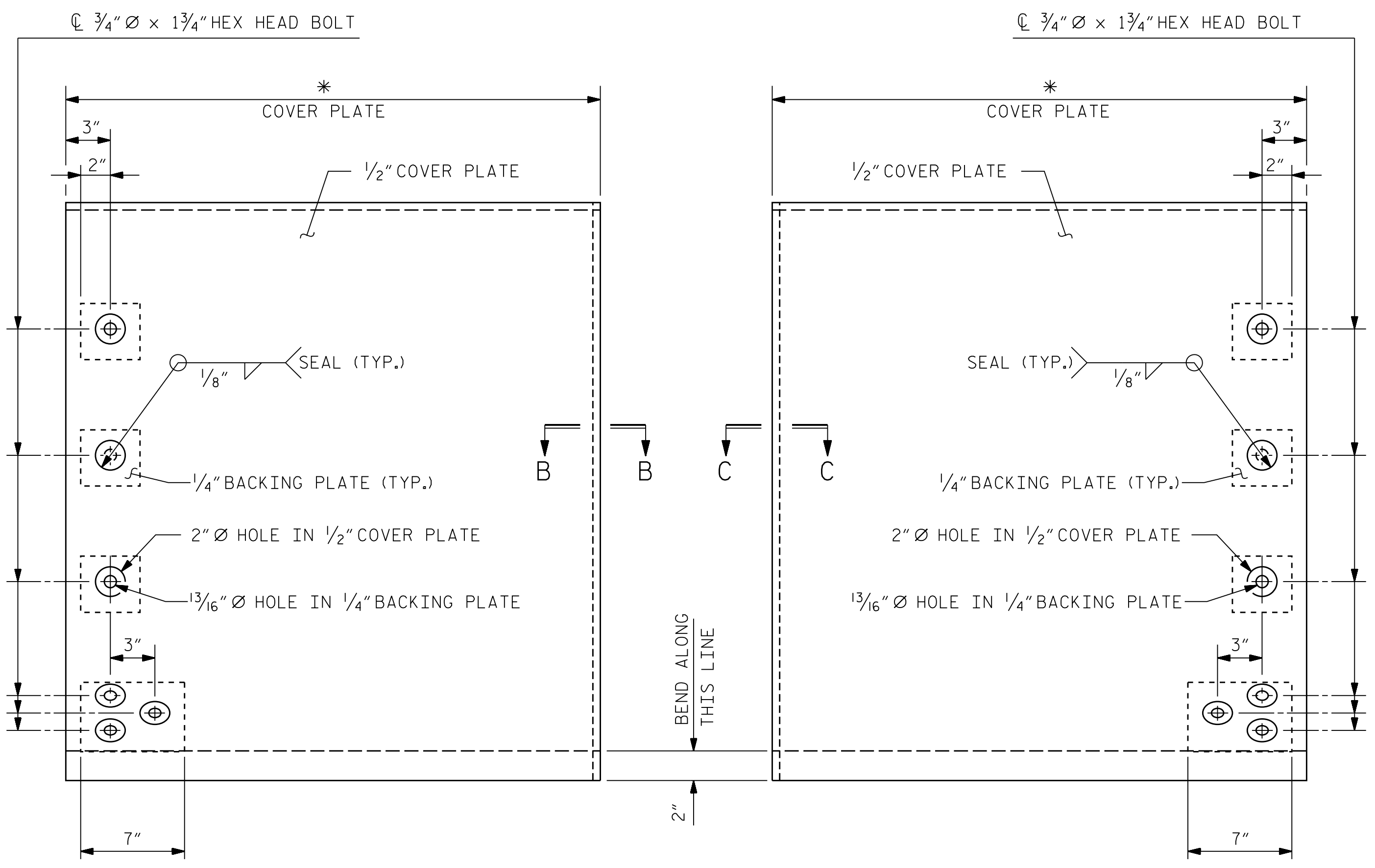

TYPE I - ELEVATION VIEW

TYPE II - ELEVATION VIEW

**NOTES**

FOR MODULAR EXPANSION JOINT SEALS, SEE SPECIAL PROVISIONS.

THE STEEL PLATES SHALL CONFORM TO AASHTO M270 GRADE 36 OR APPROVED EQUAL AND BE PAINTED IN ACCORDANCE WITH THE STANDARD SPECIFICATIONS. AT THE CONTRACTOR'S OPTION, THE PLATES MAY BE METALLIZED AFTER FABRICATION. SEE SPECIAL PROVISIONS FOR THERMAL SPRAYED COATINGS (METALLIZATION).

THE 3/4" Ø HEX HEAD BOLTS SHALL CONFORM TO ASTM F593 ALLOY 304 STAINLESS STEEL.

THE 3/4" CONCRETE INSERTS SHALL BE CLOSED-END FERRULES WITH LOOPED WIRE STRUTS ATTACHED TO THEM. THE INSERTS SHALL CONFORM TO AASHTO M169, GRADE 12L14 AND SHALL HAVE A TENSILE WORKING LOAD CAPACITY OF 3000 LBS.

APPLY A BOND BREAKER COATING TO THE INSIDE SURFACES OF THE STEEL COVER AND BACKING PLATES.

NO SEPARATE PAYMENT WILL BE MADE FOR FURNISHING AND INSTALLING THE COVER PLATE. THE ENTIRE COST OF THIS WORK SHALL BE INCLUDED IN THE LUMP SUM PRICE FOR "MODULAR EXPANSION JOINT SEALS".

FOR PAVEMENT MARKING ALIGNMENT SKETCH, SEE EXPANSION JOINT SEAL DETAILS SHEET.

LOCATION	SKWEW ANGLE	TOTAL MOVEMENT ALONG C. ROADWAY
END BENT 1	90°00'00"	4 1/8"
BENT 5	90°00'00"	8 1/16"

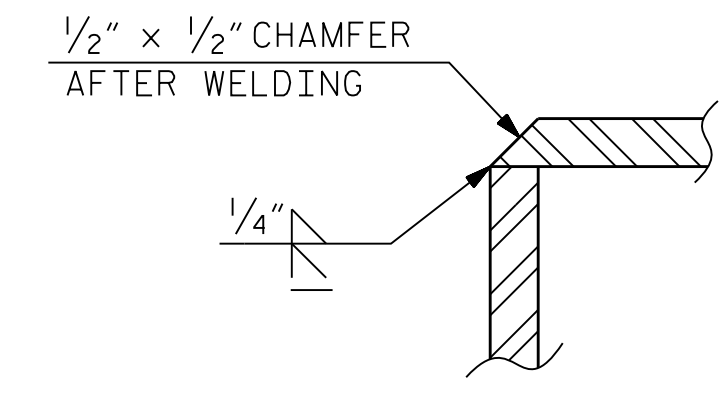

WELD DETAIL

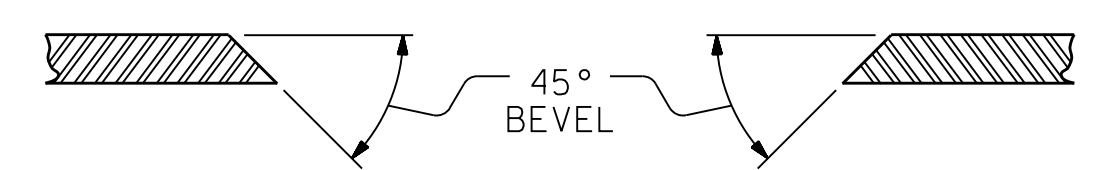

SECTION B-B

SECTION C-C

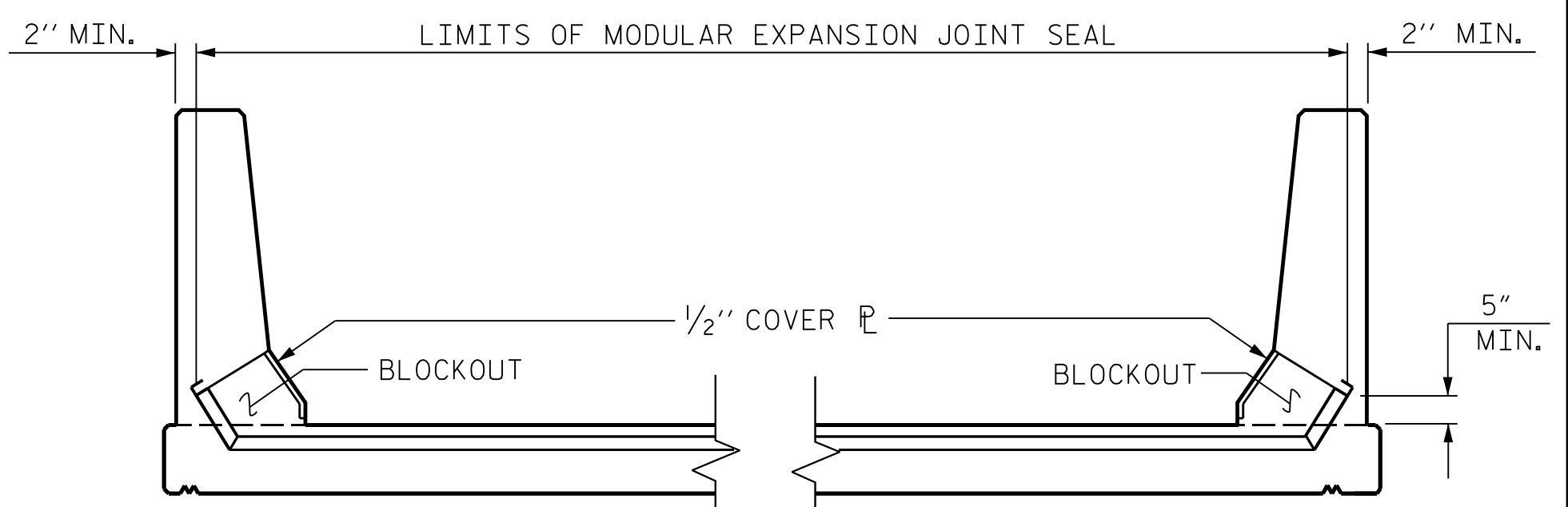

SKETCH SHOWING LIMITS OF MODULAR EXPANSION JOINT SEAL-BARRIER RAIL

▲ = OUTSIDE DIMENSIONS OF COVER PLATE TO MATCH OUTSIDE DIMENSIONS OF CONCRETE BARRIER RAIL  
 # = 1/4" x 6" x 7" BACKING PLATE

**COVER PLATE DETAILS**

\* = DETAILS OF COVER PLATES ARE SUBJECT TO CHANGE DEPENDING ON THE DETAILS OF THE MODULAR EXPANSION JOINT SEALS FURNISHED.

LOCATION	"A" (in.)		
	45° F	60° F	90° F
END BENT 1	3 1/16"	3 1/16"	1 3/16"
BENT 5	6 5/8"	5 5/16"	2 3/4"

LOCATION	"B" (in.)		
	45° F	60° F	90° F
END BENT 1	3 1/16"	3 1/16"	1 3/16"
BENT 5	6 5/8"	5 5/16"	2 3/4"

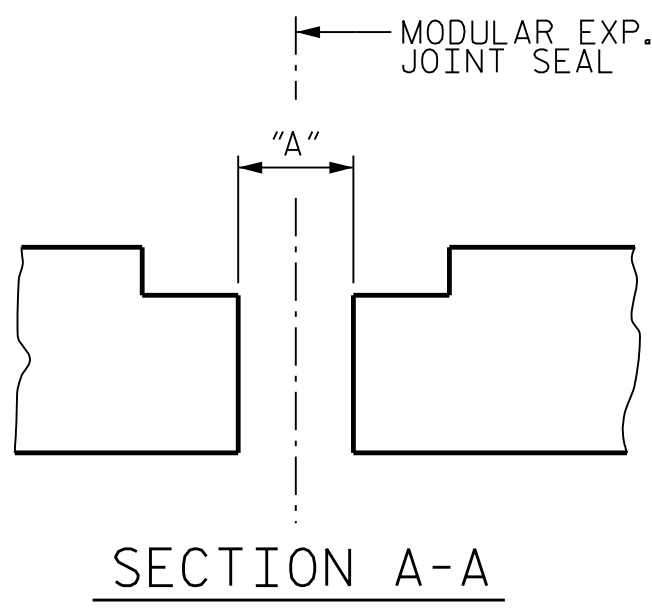

SECTION A-A

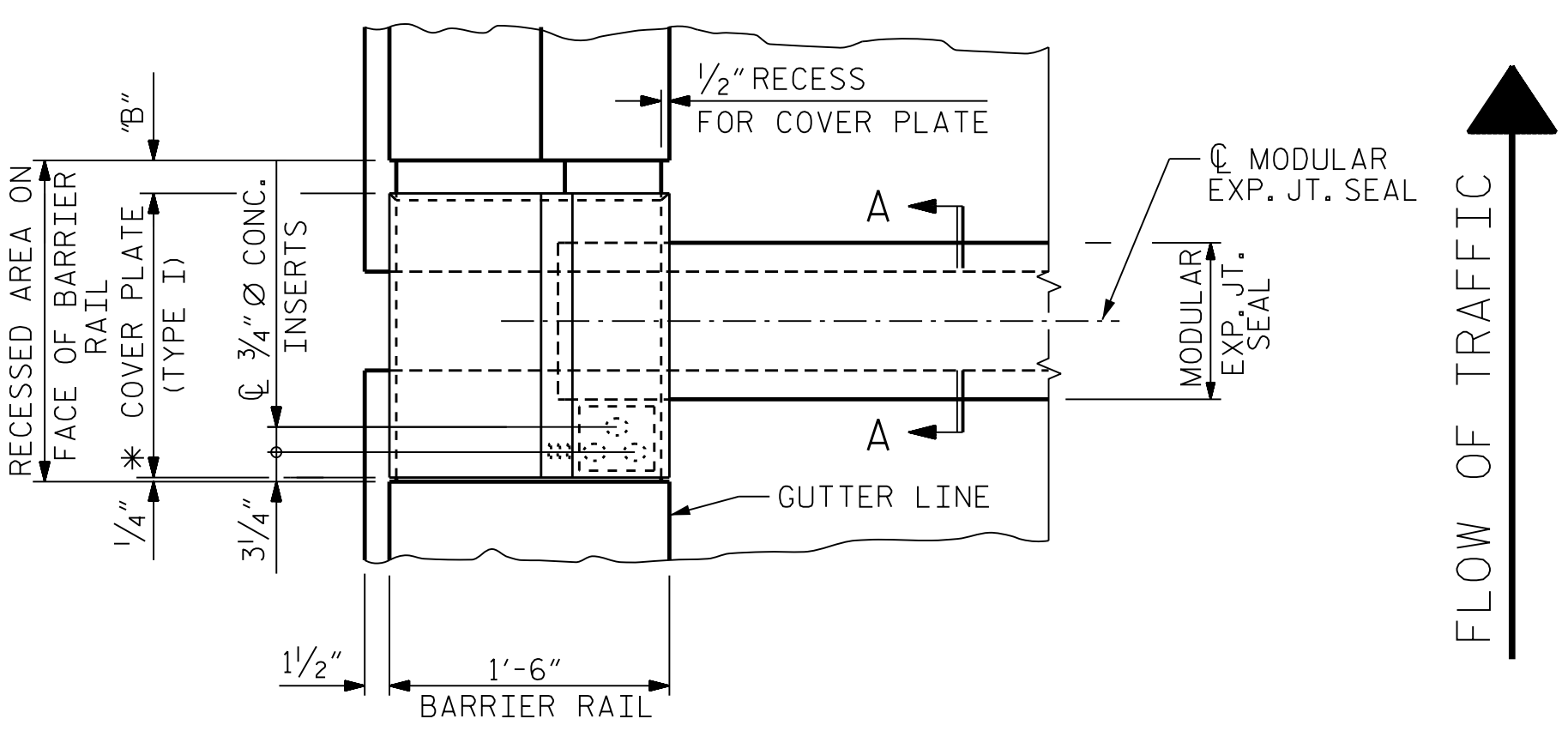

PLAN OF MODULAR EXPANSION JOINT SEAL - LEFT SIDE

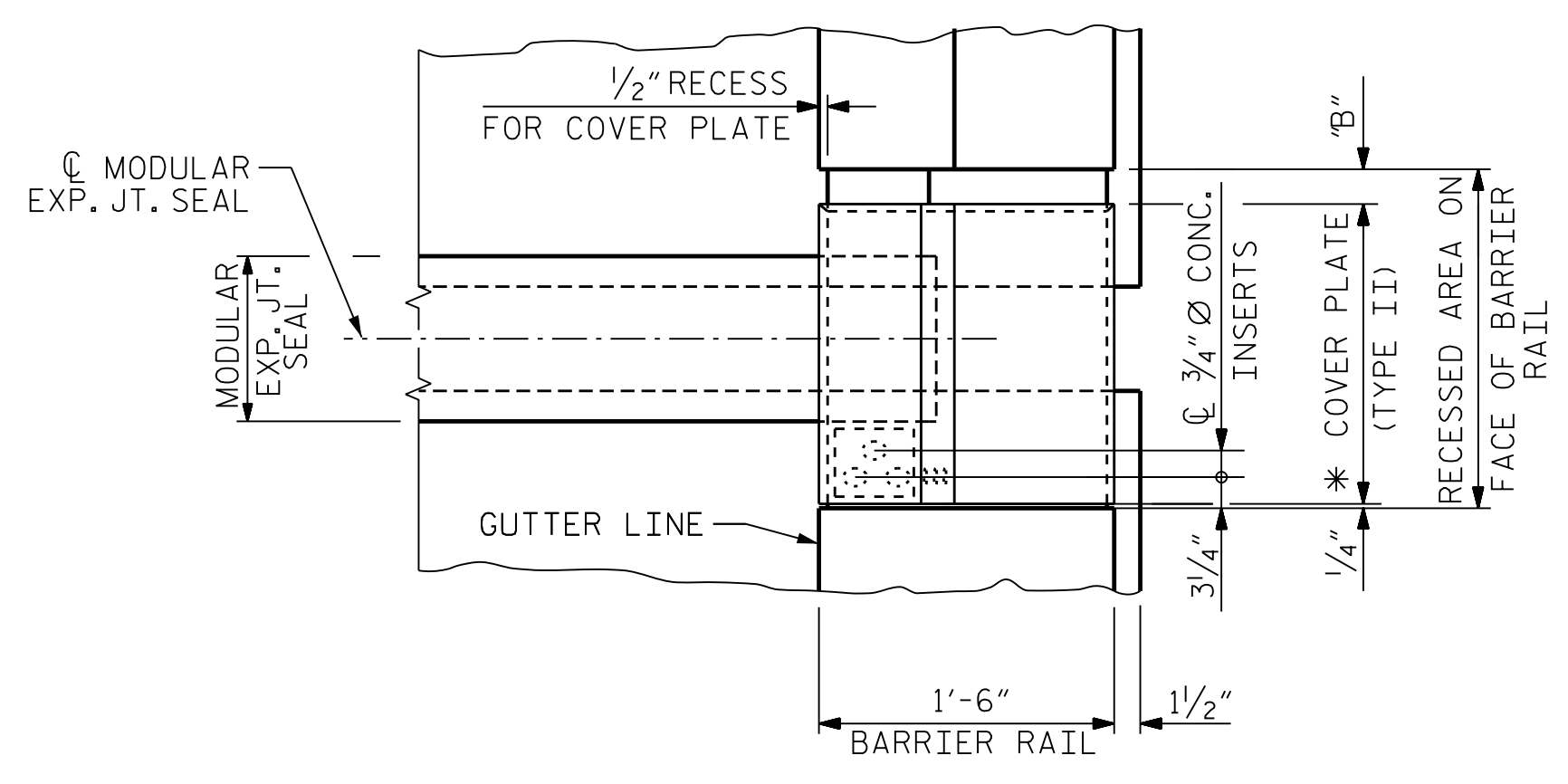

PLAN OF MODULAR EXPANSION JOINT SEAL - RIGHT SIDE

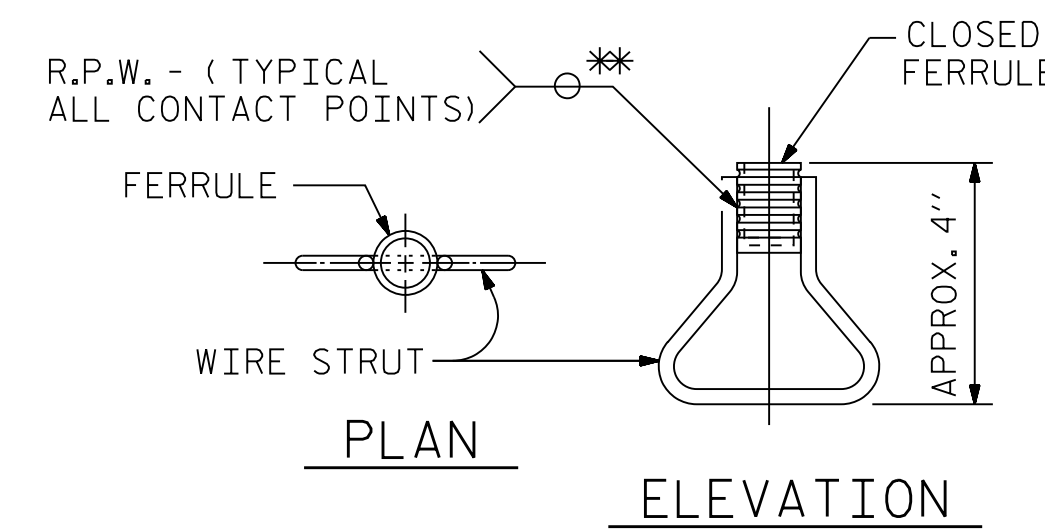

**CONCRETE INSERT**

\* EACH WELDED ATTACHMENT OF WIRE TO FERRULE SHALL DEVELOP THE TENSILE STRENGTH OF THE WIRE.



PROJECT NO. U-2579AB  
 FORSYTH COUNTY  
 STATION: 60+66.06 -Y15FLYAC-

STATE OF NORTH CAROLINA  
 DEPARTMENT OF TRANSPORTATION  
 RALEIGH  
 MODULAR EXPANSION JOINT SEAL DETAILS FOR BARRIER RAIL

REVISIONS						SHEET NO. S04-085
NO.	BY:	DATE:	NO.	BY:	DATE:	
1	--	--	3	--	--	TOTAL SHEETS 144
2	--	--	4	--	--	

PLOT DRIVER: NCDOT...  
 USER: PPRETERSO  
 FILE: ...

DES BY: T. ANDREWS DATE: 10/19  
 DES CHK: G. SCHMITZ DATE: 10/19  
 DWG BY: T. SAS DATE: 10/19  
 CHK BY: T. ANDREWS DATE: 11/19



DOCUMENT NOT CONSIDERED FINAL UNLESS ALL SIGNATURES COMPLETED

CONCRETE BREAKDOWN

POUR	UNIT 1 CU. YDS.	UNIT 2 CU. YDS.
1	198.5	158.8
2	135.7	241.7
3	152.8	204.0
4	213.1	179.0
5	179.7	163.5
6	112.3	201.5
7	163.8	191.3
8	142.7	159.7
9	109.2	8.8
10	8.9	8.3
11	8.0	-
TOTAL	1,424.7	1,516.6

GROOVING BRIDGE FLOORS

APPROACH SLABS	1,812 SQ.FT.
BRIDGE DECK	69,396 SQ.FT.
TOTAL	71,208 SQ.FT.

SUPERSTRUCTURE REINFORCING STEEL LENGTHS ARE BASED ON THE FOLLOWING MINIMUM SPLICE LENGTHS

BAR SIZE	SUPERSTRUCTURE EXCEPT APPROACH SLABS, PARAPET, AND BARRIER RAIL		APPROACH SLABS		PARAPET AND BARRIER RAIL
	EPOXY COATED	UNCOATED	EPOXY COATED	UNCOATED	
#4	1'-11"	1'-7"	1'-11"	1'-7"	2'-6"
#5	2'-5"	2'-0"	2'-5"	2'-0"	3'-1"
#6	2'-10"	2'-5"	3'-7"	2'-5"	3'-8"
#7	4'-2"	2'-9"			
#8	4'-9"	3'-2"			

NOTES

\*\* = QUANTITIES FOR BARRIER RAIL ARE NOT INCLUDED.

PERFORM BRIDGE DECK GROOVING IN ACCORDANCE WITH STANDARD SPEC. ITEM 420-14.

THE CONCRETE DECK QUANTITIES INCLUDE CONCRETE IN THE STAY-IN-PLACE FORM FLUTES. AN ADDITIONAL 1" OF DECK THICKNESS WAS CONSIDERED WHERE STAY-IN-PLACE FORMS ARE USED.

DECK SLAB TRANSVERSE CONSTRUCTION JOINTS ARE RADIAL (EXCEPT JOINTS FOR 4'-0" CLOSURE POURS AT EXPANSION JOINTS).

BILL OF MATERIAL DECK & DIAPHRAGM-UNIT 1

BAR NO.	NO.	SIZE	TYPE	LENGTH	WEIGHT
*A1	2,219	#5	STR	42'-11"	99,327
A2	2,219	#5	STR	42'-11"	99,327
*B1	16	#4	STR	34'-1"	364
*B2	77	#4	STR	37'-1"	1,907
*B3	87	#6	STR	57'-0"	7,448
*B4	93	#4	STR	30'-0"	1,864
*B5	261	#6	STR	60'-0"	23,521
*B6	87	#6	STR	41'-10"	5,467
*B7	124	#4	STR	39'-10"	3,299
*B8	87	#6	STR	36'-10"	4,813
*B9	93	#4	STR	33'-1"	2,055
*B10	174	#6	STR	31'-4"	8,189
*B11	109	#4	STR	32'-11"	2,397
*B12	15	#4	STR	29'-11"	300
B101	976	#5	STR	59'-1"	60,145
*G1	22	#5	5	3'-8"	84
*K1	12	#5	2	11'-8"	146
*K2	12	#5	3	16'-6"	207
*S1	38	#4	1	5'-4"	135
*S2	38	#4	1	4'-7"	116

\* EPOXY COATED BARS  
REINFORCING STEEL LBS. 159,472  
EPOXY COATED REINF. STEEL LBS. 161,639

BILL OF MATERIAL DECK & DIAPHRAGM-UNIT 2

BAR NO.	NO.	SIZE	TYPE	LENGTH	WEIGHT
*A1	2,338	#5	STR	42'-11"	104,654
A2	2,338	#5	STR	42'-11"	104,654
*B5	522	#6	STR	60'-0"	47,043
*B13	16	#4	STR	32'-6"	347
*B14	77	#4	STR	35'-6"	1,826
*B15	174	#6	STR	33'-4"	8,712
*B16	93	#4	STR	31'-5"	1,952
*B17	87	#6	STR	42'-8"	5,575
*B18	124	#4	STR	37'-4"	3,092
*B19	87	#6	STR	20'-8"	2,701
*B20	62	#4	STR	33'-1"	1,370
*B21	87	#6	STR	17'-10"	2,330
*B22	78	#4	STR	36'-6"	1,902
*B23	15	#4	STR	33'-6"	336
B102	1,037	#5	STR	59'-3"	64,084
*G1	11	#5	5	3'-8"	42
*G2	1	#5	STR	42'-11"	45
*J1	41	#4	4	1'-5"	39
*K1	12	#5	2	11'-8"	146
*K2	12	#5	3	16'-6"	207
*S1	38	#4	1	5'-4"	135
*S2	41	#4	1	4'-7"	126

\* EPOXY COATED BARS  
REINFORCING STEEL LBS. 168,738  
EPOXY COATED REINF. STEEL LBS. 182,580

BAR TYPES

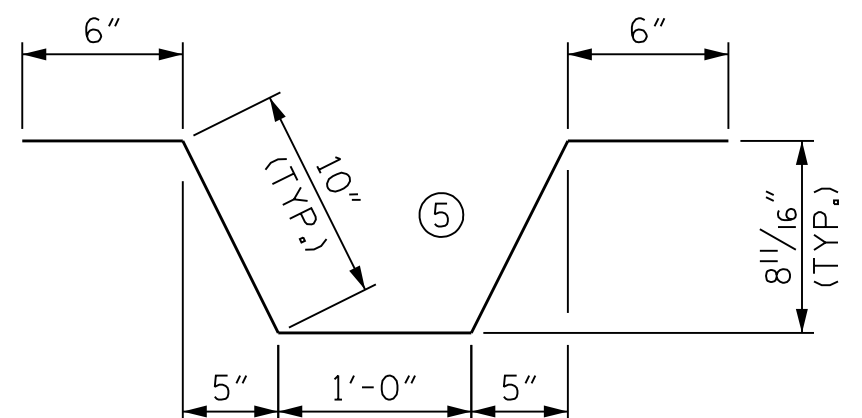
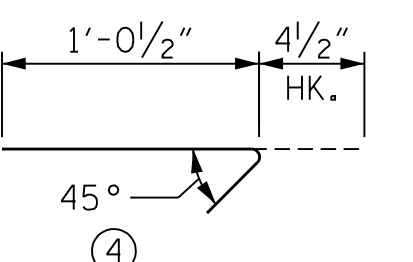
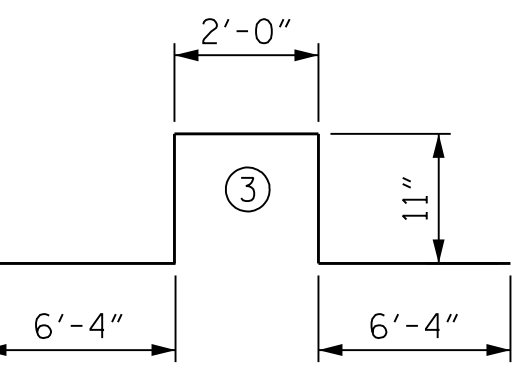
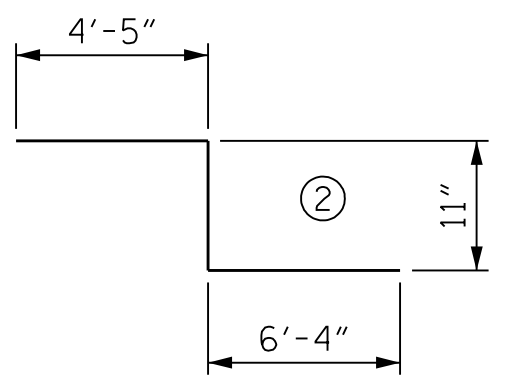
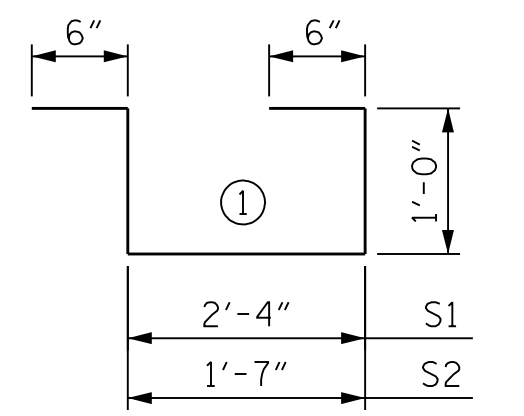

ALL BAR DIMENSIONS ARE OUT TO OUT

SUPERSTRUCTURE BILL OF MATERIAL

	CLASS AA CONCRETE	REINFORCING STEEL	EPOXY COATED REINFORCING STEEL
	CU. YARDS	LBS.	LBS.
UNIT 1	1,424.7	159,472	161,639
UNIT 2	1,516.6	168,738	182,580
TOTAL **	2,941.3	328,210	344,219

PROJECT NO. U-2579AB  
FORSYTH COUNTY  
STATION: 60+66.06 -Y15FLYAC-

STATE OF NORTH CAROLINA  
DEPARTMENT OF TRANSPORTATION  
RALEIGH

SUPERSTRUCTURE BILL OF MATERIAL

REVISIONS						SHEET NO.	
NO.	BY:	DATE:	NO.	BY:	DATE:	NO.	
1	--	--	3	--	--	TOTAL SHEETS	
2	--	--	4	--	--	144	

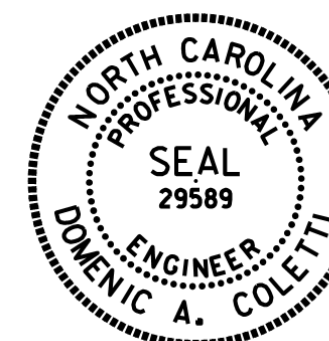

10/15/2021

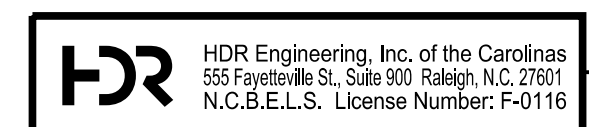

DOCUMENT NOT CONSIDERED FINAL UNLESS ALL SIGNATURES COMPLETED

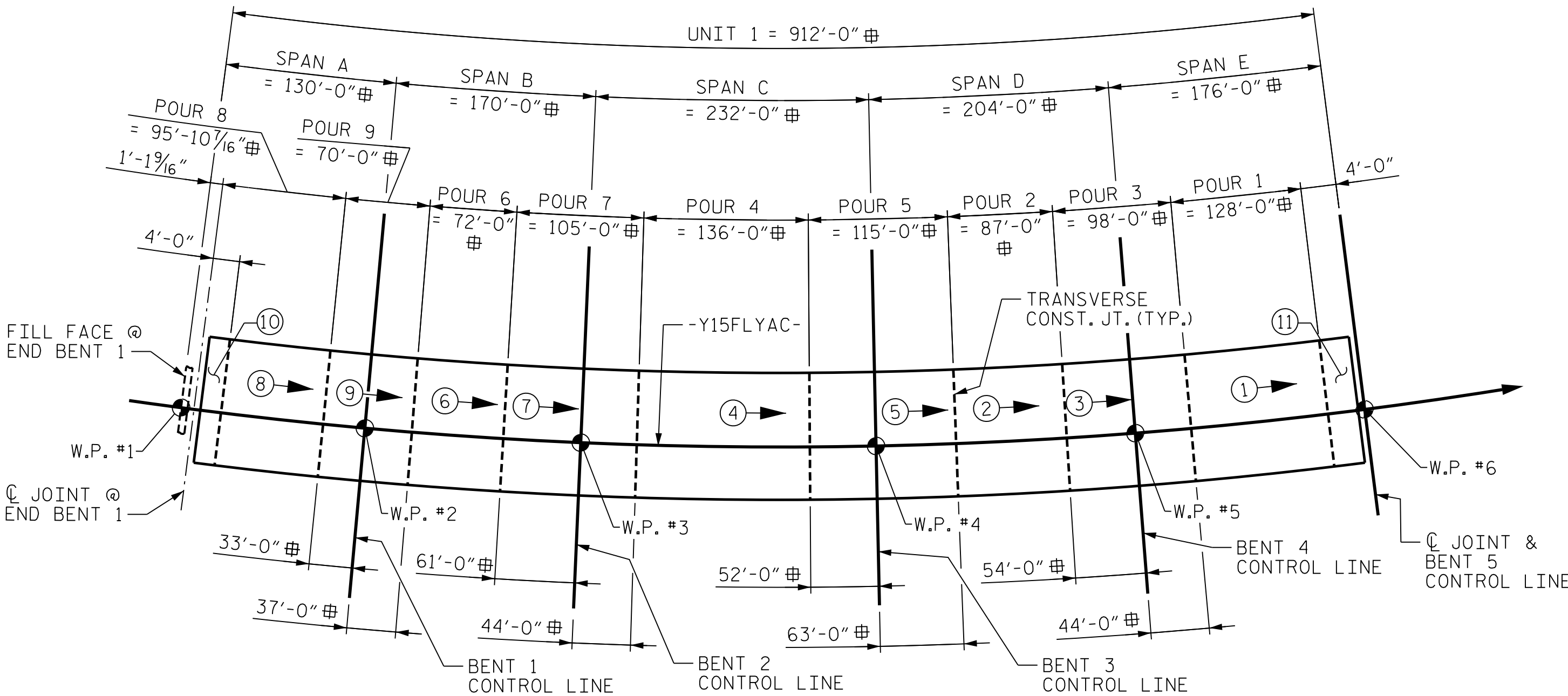

POUR DIAGRAM - UNIT 1

⊕ = DIMENSIONS ARE MEASURED ALONG -Y15FLYAC-

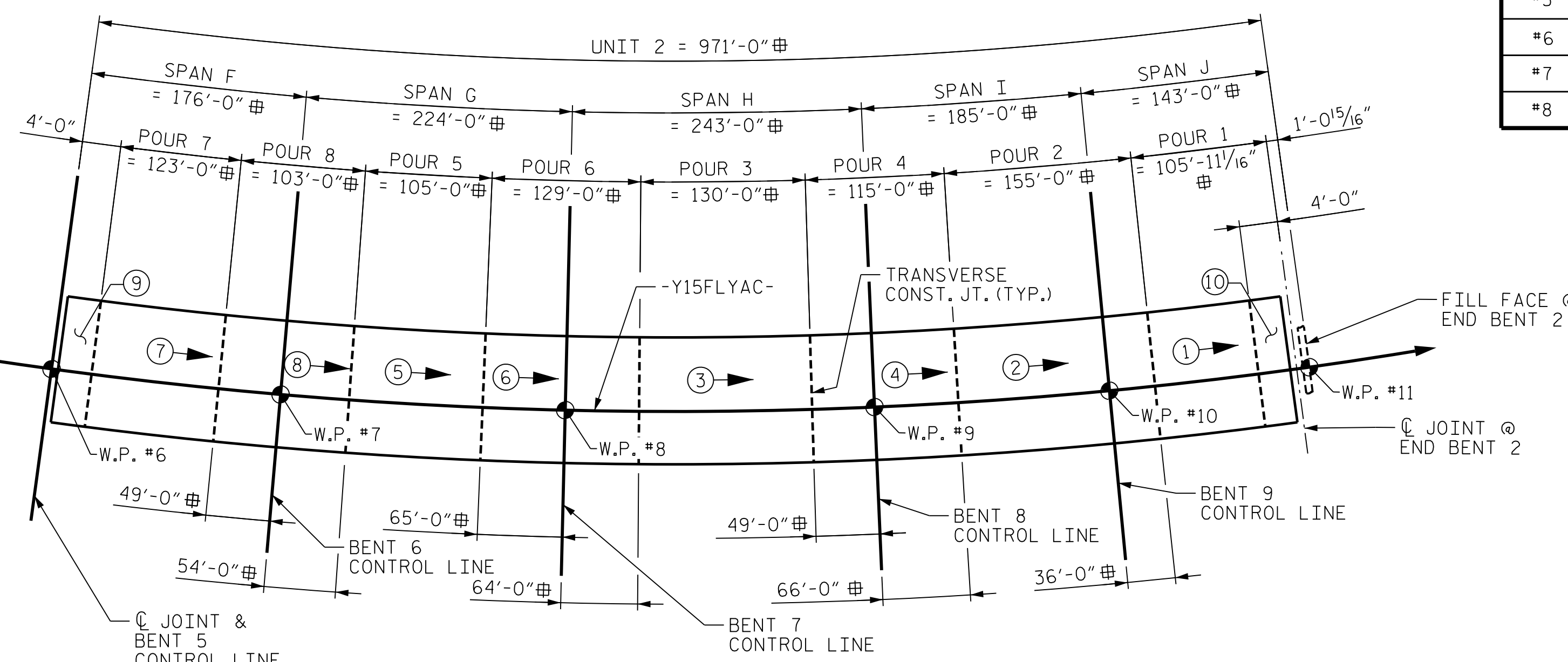

POUR DIAGRAM - UNIT 2

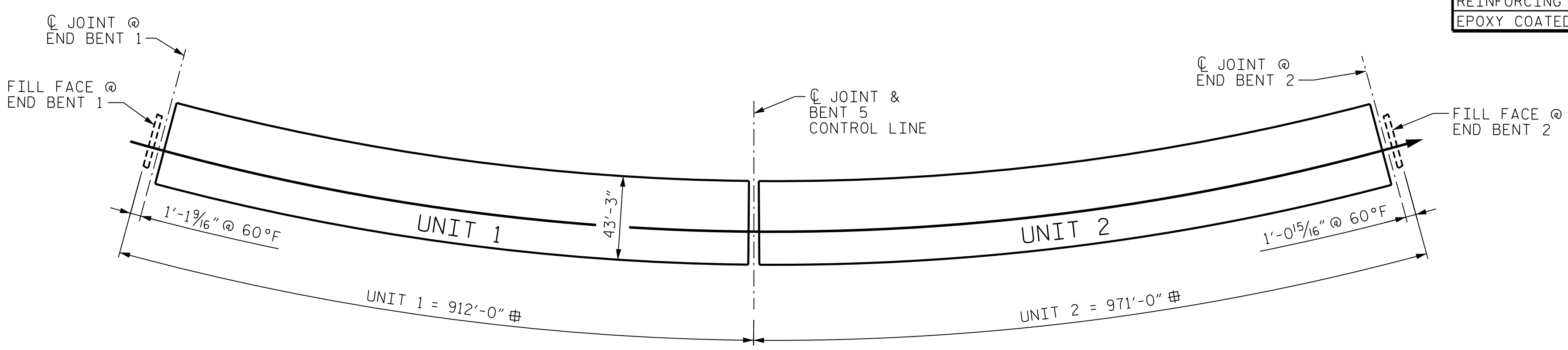

LAYOUT FOR COMPUTING AREA OF REINFORCED CONCRETE DECK SLAB (SQ. FEET = 81,227)

DES BY: T. ANDREWS DATE: 09/19 DWG BY: K. RYAN DATE: 09/19  
DES CHK: D. OLDS DATE: 09/19 CHK BY: G. SCHMITZ DATE: 11/19

PLOT DRIVER: NCDOT\_STRUCTURES\_DEFAULT.PEN.tbl  
USER: PPETERSO DATE: 10/14/2021  
FILE: ... \SUPERS

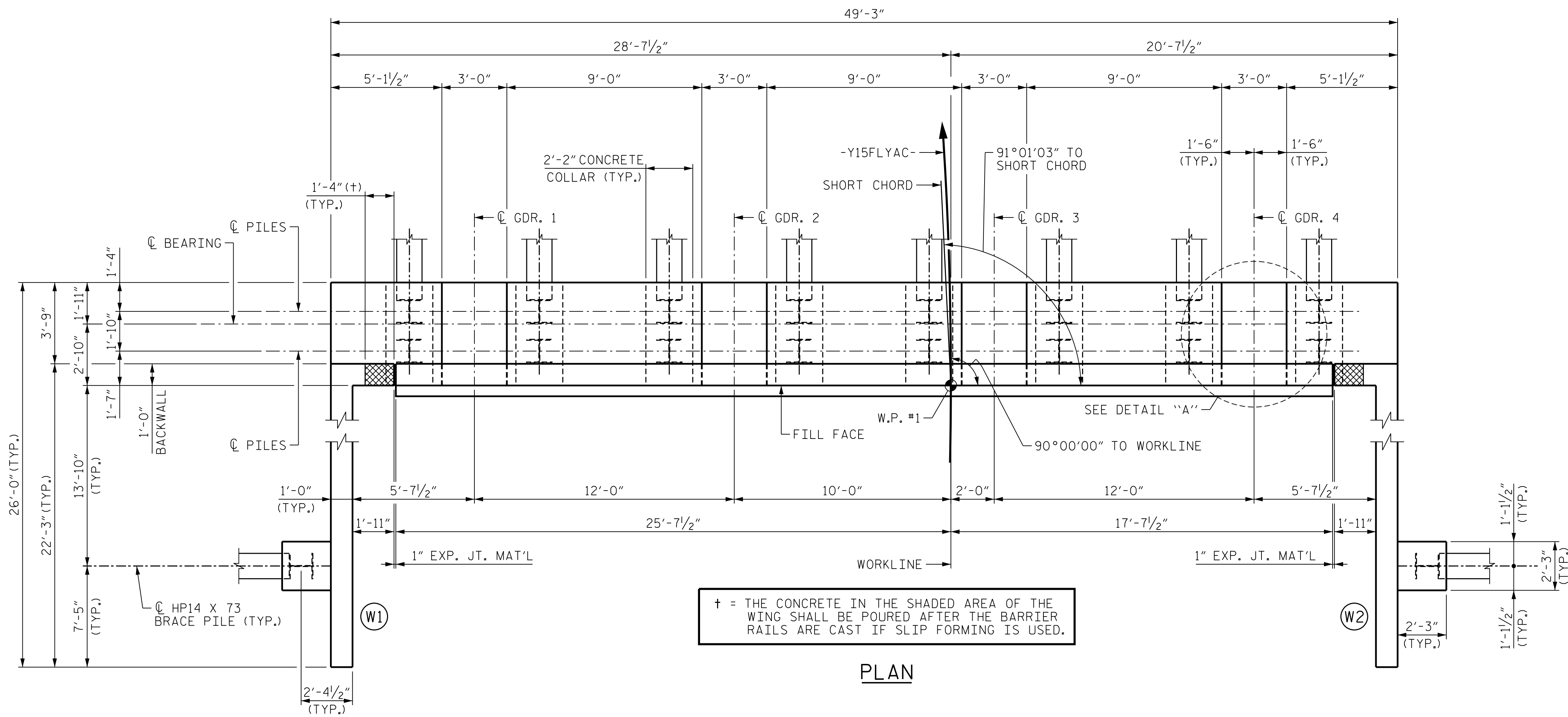

† = THE CONCRETE IN THE SHADED AREA OF THE WING SHALL BE POURED AFTER THE BARRIER RAILS ARE CAST IF SLIP FORMING IS USED.

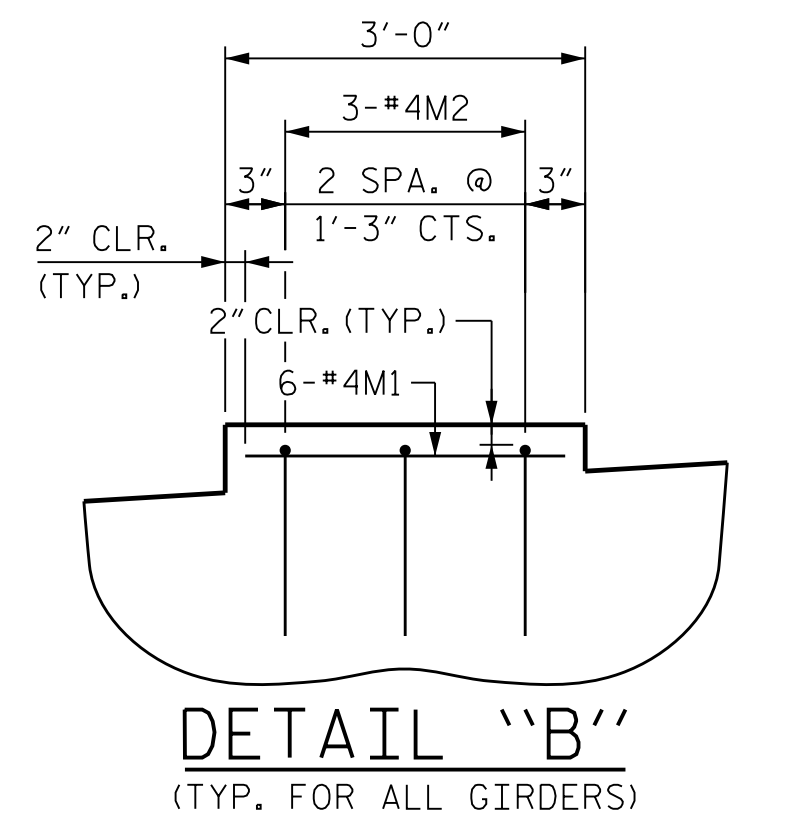
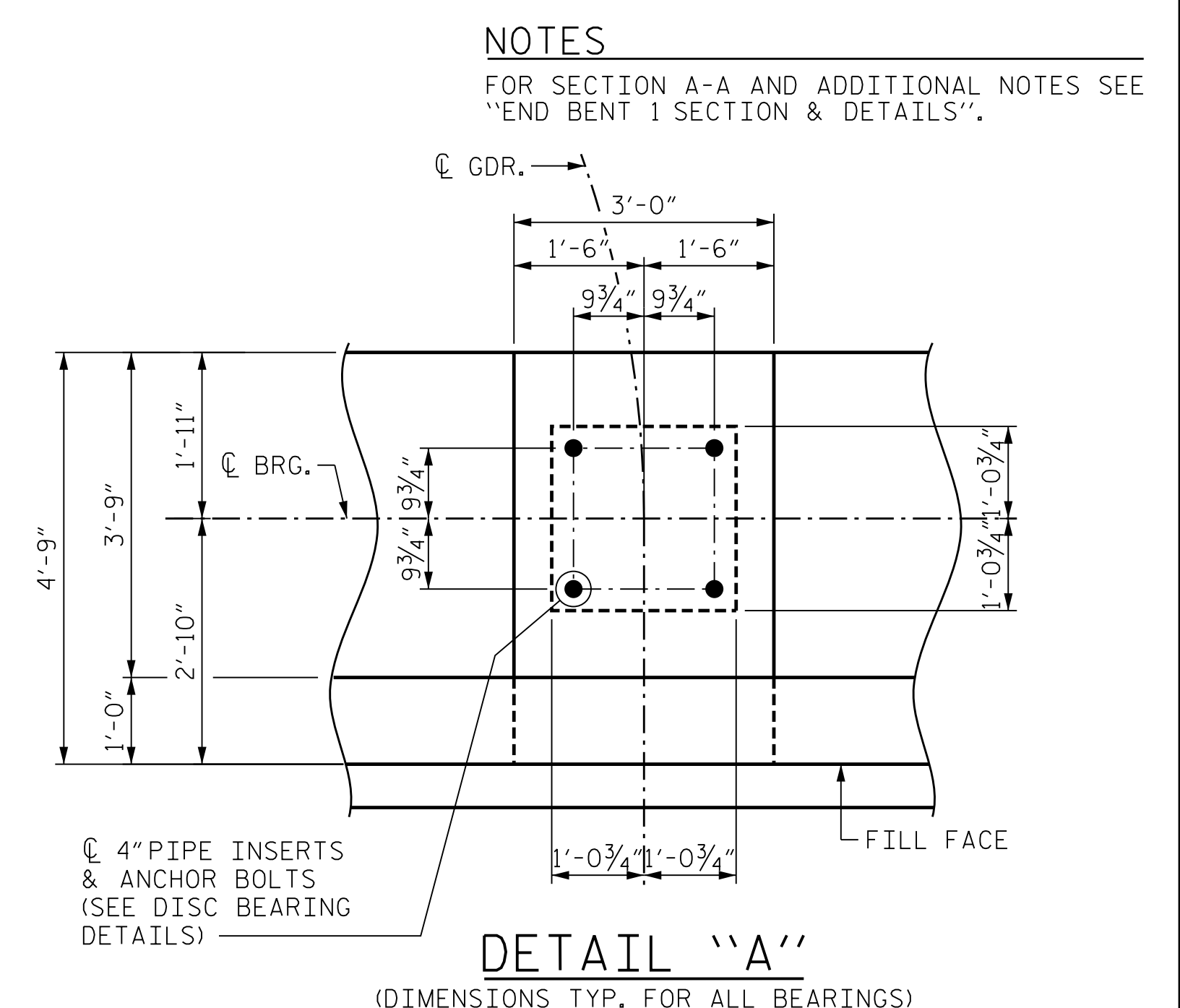

**ELEVATION TABLE**

LOCATION	ELEVATION
A	924.64
B	925.12
C	925.60
D	926.08
* X	932.63
* Y	933.65
* Z	934.36
* AT FILL FACE	

**TOP OF PILE ELEVATIONS**

LOCATION	ELEVATION
1	922.30
2	922.54
3	922.78
4	923.02
5	923.26
6	923.50
7	923.74
8	923.98

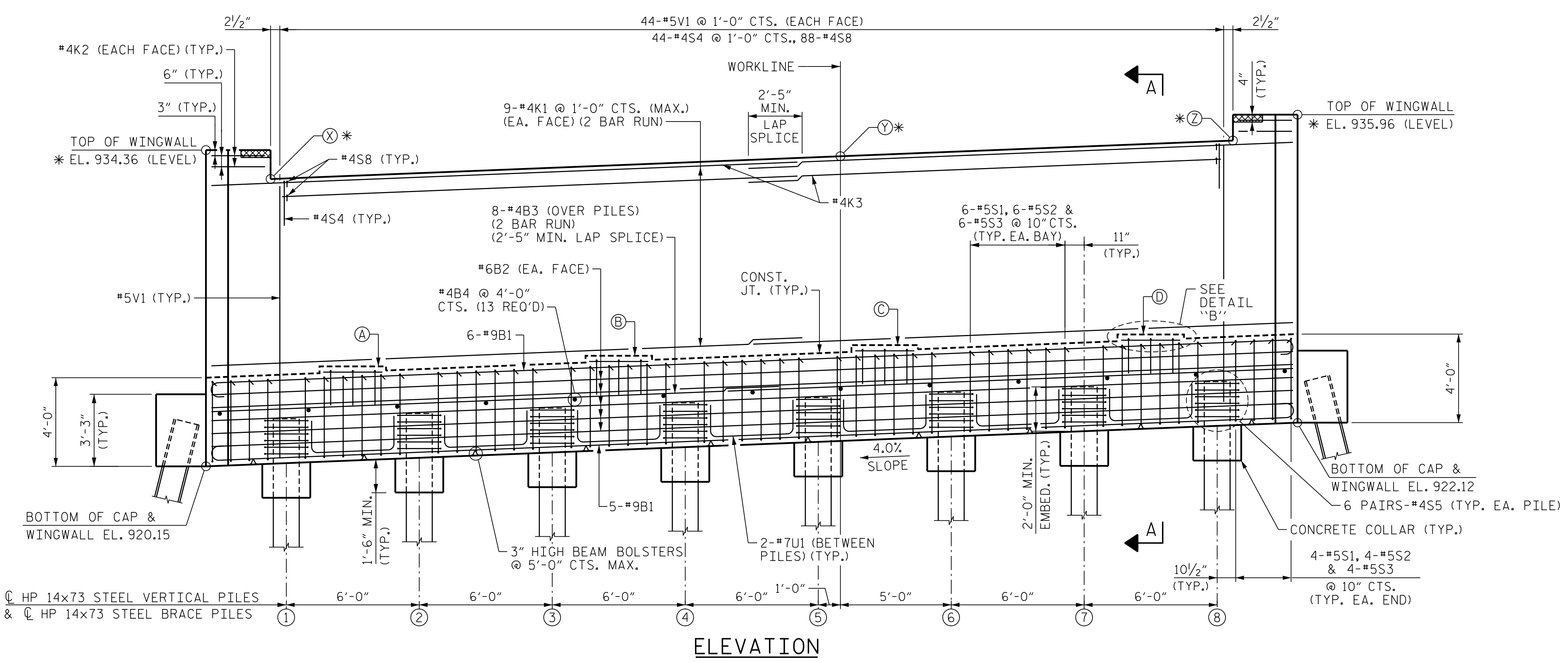

PROJECT NO. U-2579AB

FORSYTH COUNTY

STATION: 60+66.06 -Y15FLYAC-

SHEET 1 OF 3



STATE OF NORTH CAROLINA  
DEPARTMENT OF TRANSPORTATION  
RALEIGH

**SUBSTRUCTURE  
END BENT 1  
PLAN AND ELEVATION**

**REVISIONS**

NO.	BY:	DATE:	NO.	BY:	DATE:
1	--	--	3	--	--
2	--	--	4	--	--

SHEET NO. S04-087  
TOTAL SHEETS 144

PLOT DRIVER: NCDOT...  
USER: PPETERSO  
DATE: 10/14/2021  
FILE: ...SUBSTR

DES BY: J. EARNEST DATE: 07/19  
DES CHK: T. STOKES DATE: 08/19

DWG BY: B. PETERSON DATE: 07/19  
CHK BY: A. ZEITOUNI DATE: 08/19

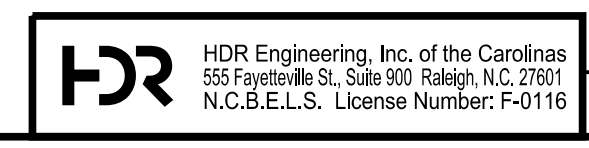

10/15/2021

DOCUMENT NOT CONSIDERED FINAL  
UNLESS ALL SIGNATURES COMPLETED

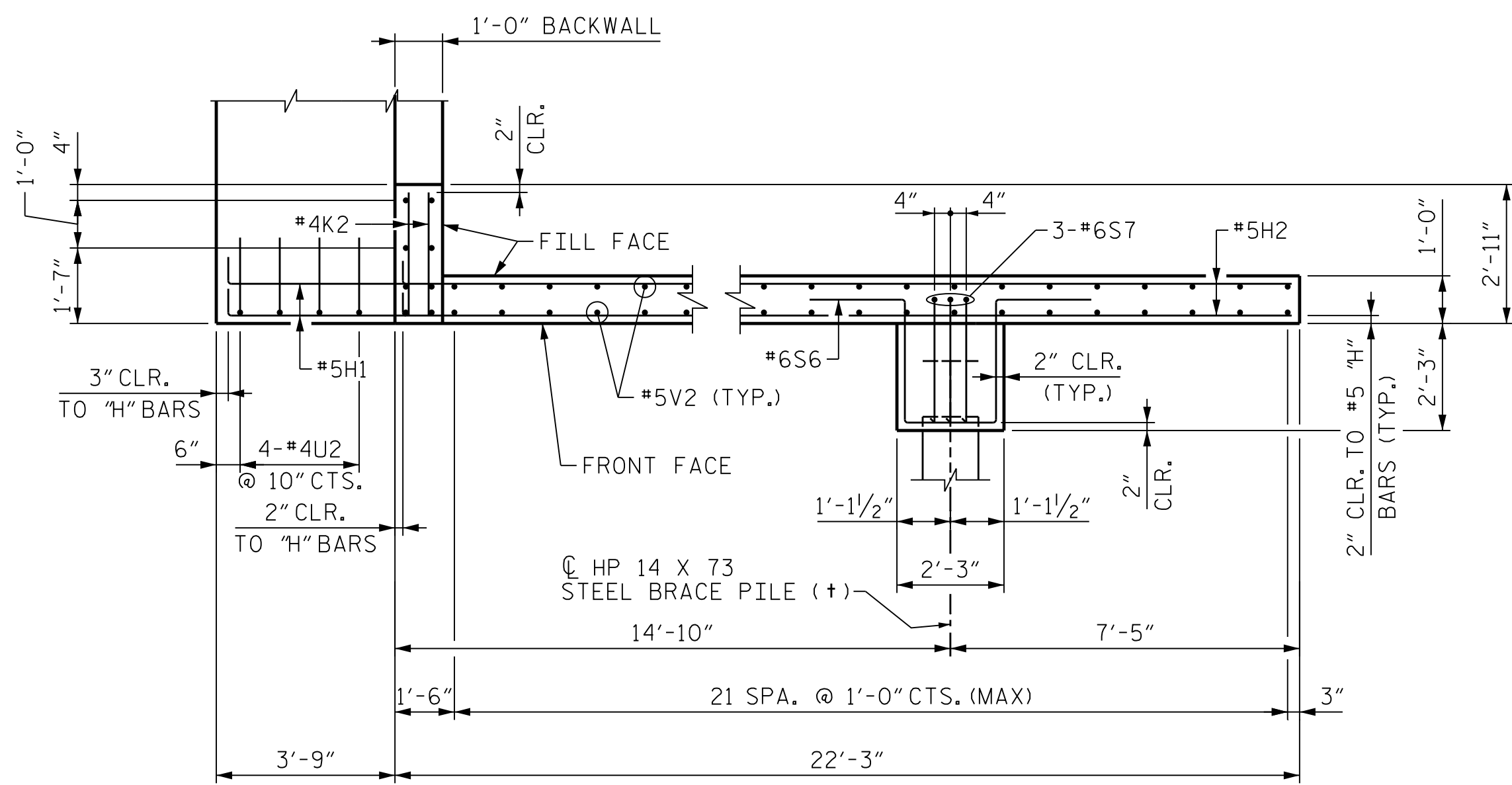

PLAN - WINGWALL "W1"

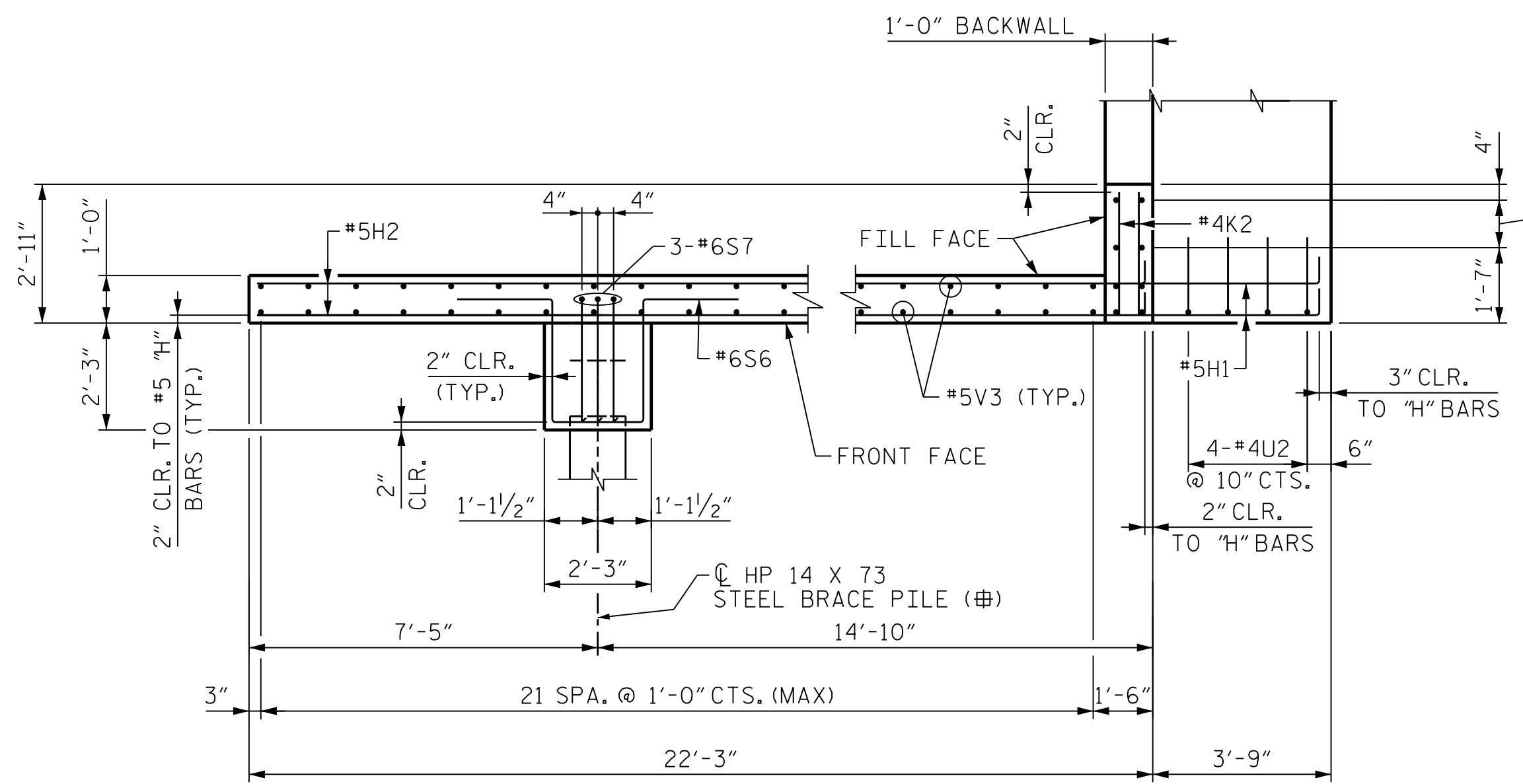

PLAN - WINGWALL "W2"

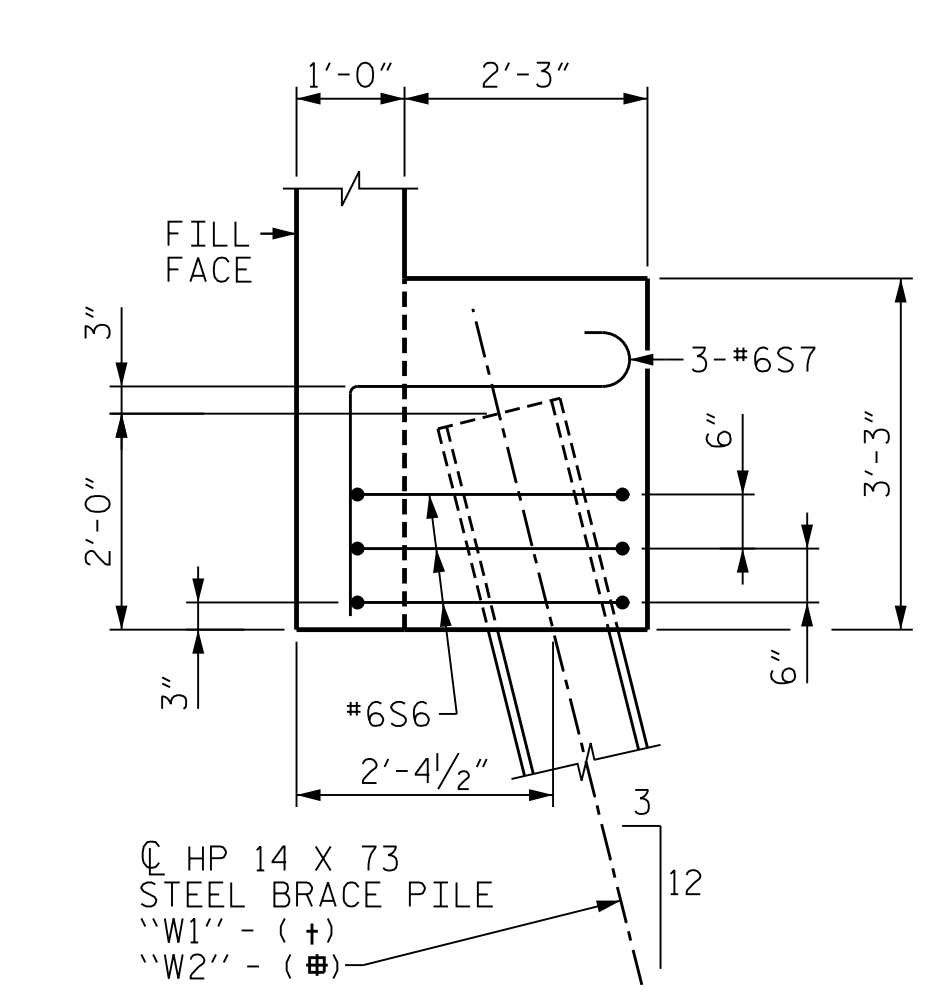

SECTION B-B

† = PILE CUTOFF ELEVATION 922.15  
 # = PILE CUTOFF ELEVATION 924.12

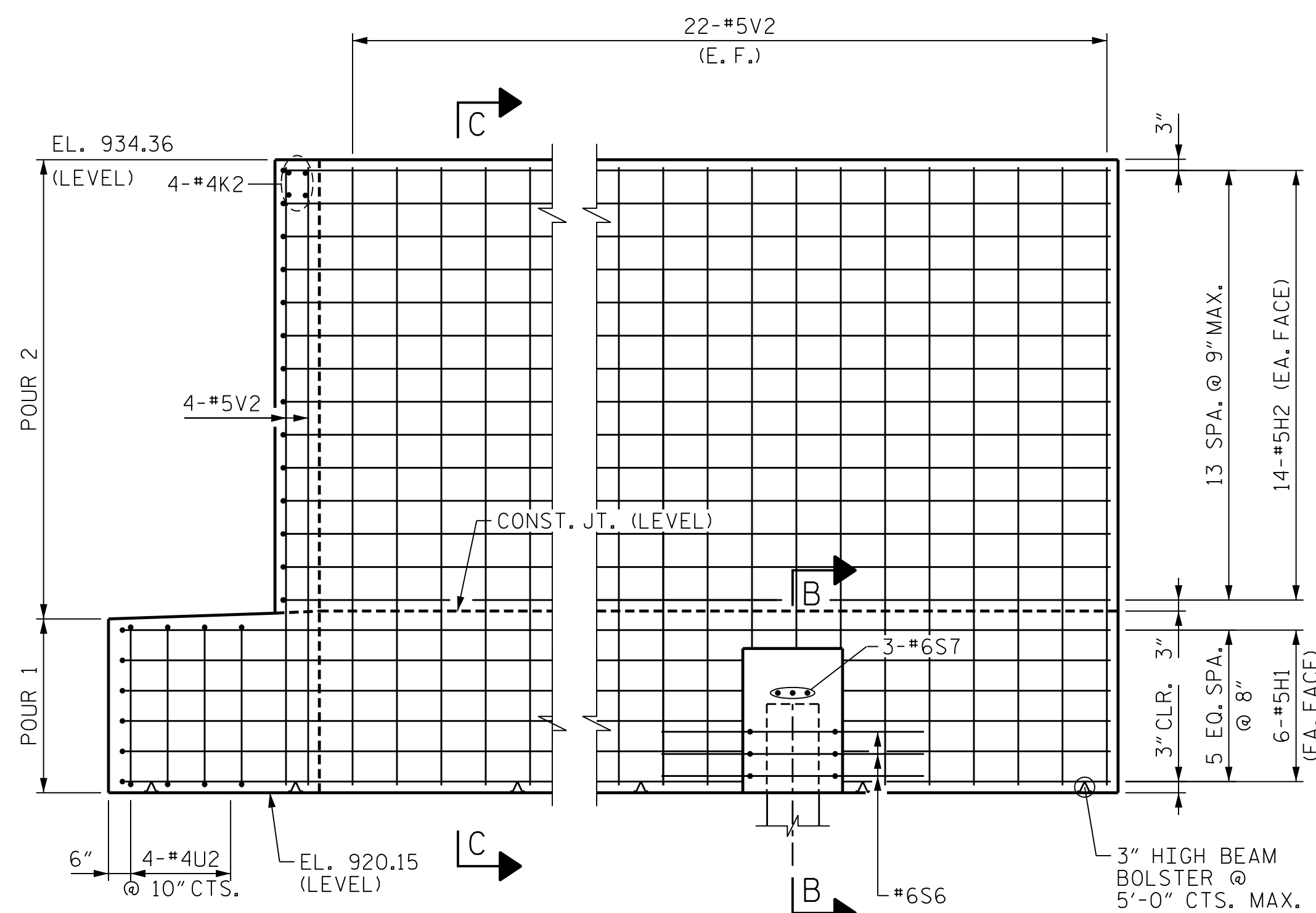

ELEVATION - WINGWALL "W1"

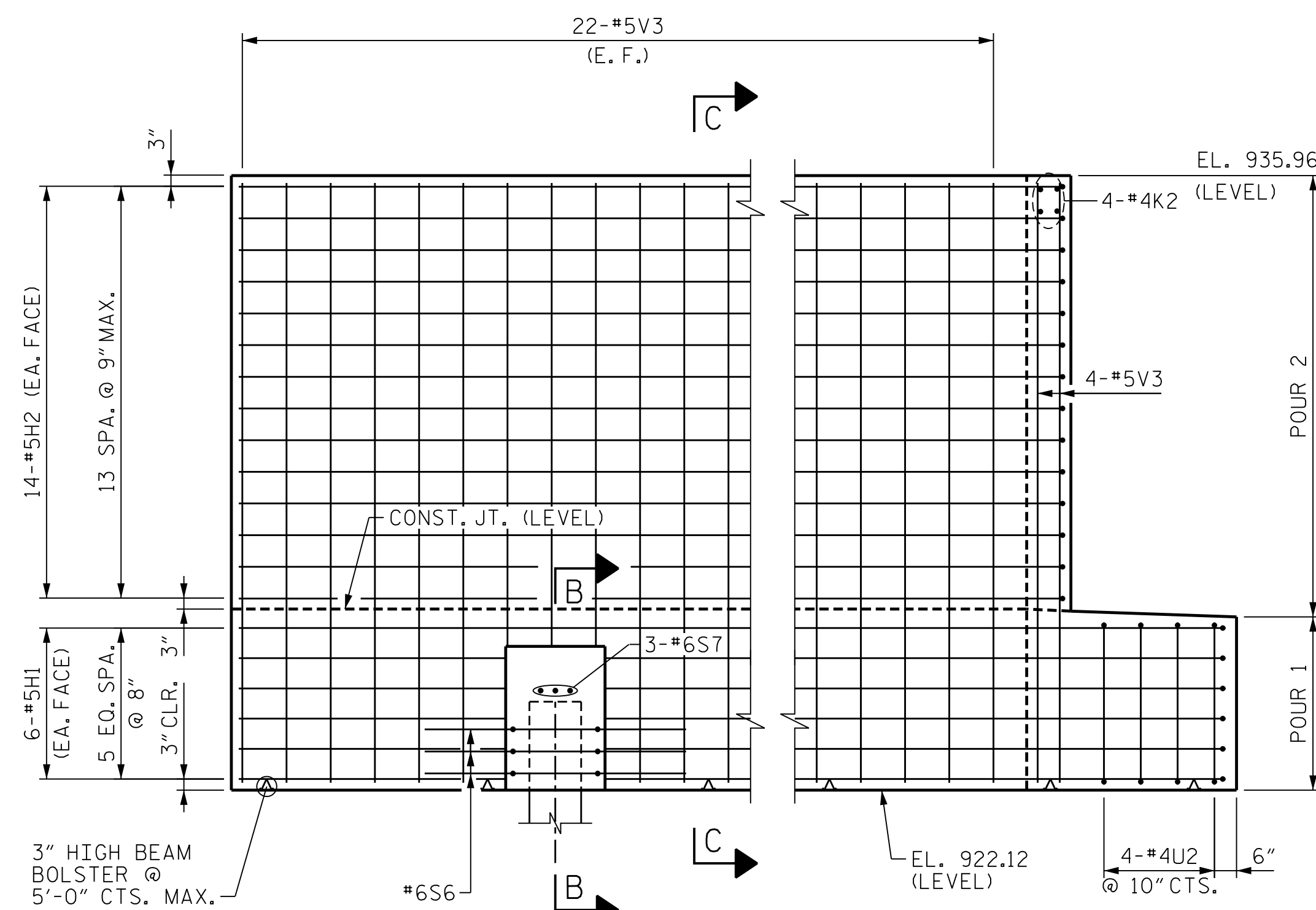

ELEVATION - WINGWALL "W2"

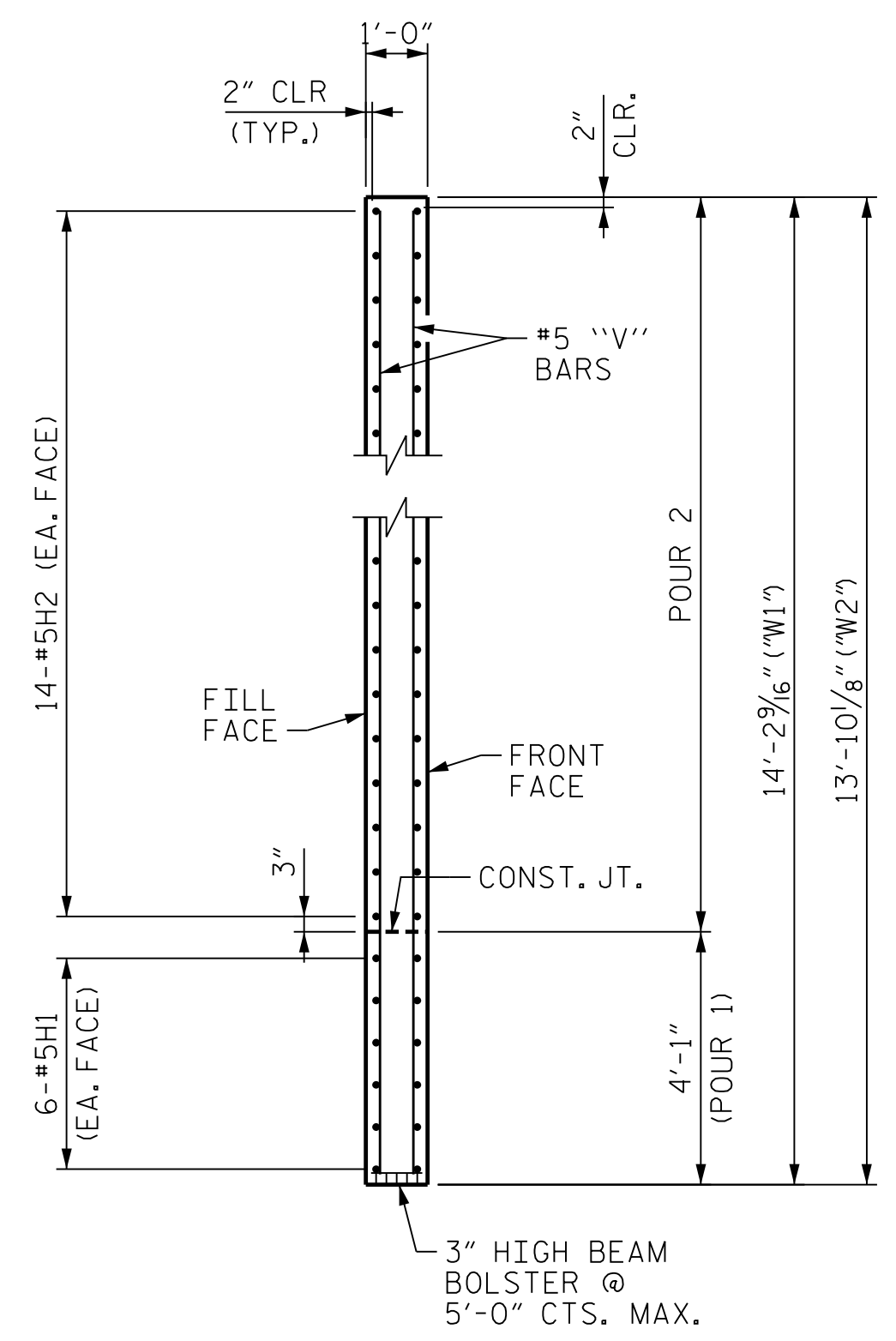

SECTION C-C

PROJECT NO. U-2579AB  
 FORSYTH COUNTY  
 STATION: 60+66.06 -Y15FLYAC-

SHEET 2 OF 3

STATE OF NORTH CAROLINA  
 DEPARTMENT OF TRANSPORTATION  
 RALEIGH

SUBSTRUCTURE  
 END BENT 1  
 WING DETAILS



10/15/2021

DES BY: J. EARNEST	DATE: 07/19	DWG BY: B. PETERSON	DATE: 07/19
DES CHK: T. STOKES	DATE: 08/19	CHK BY: A. ZEITOUNI	DATE: 08/19



DOCUMENT NOT CONSIDERED FINAL  
 UNLESS ALL SIGNATURES COMPLETED

REVISIONS					
NO.	BY:	DATE:	NO.	BY:	DATE:
1	--	--	3	--	--
2	--	--	4	--	--

SHEET NO. S04-088
TOTAL SHEETS 144

PLOT DRIVER: NCDOT\_pdf\_color\_eng-50dpi  
 USER: PETERSON DATE: 10/14/2021  
 TIME: 4:04:43 PM  
 FILE: ...SUBSTR

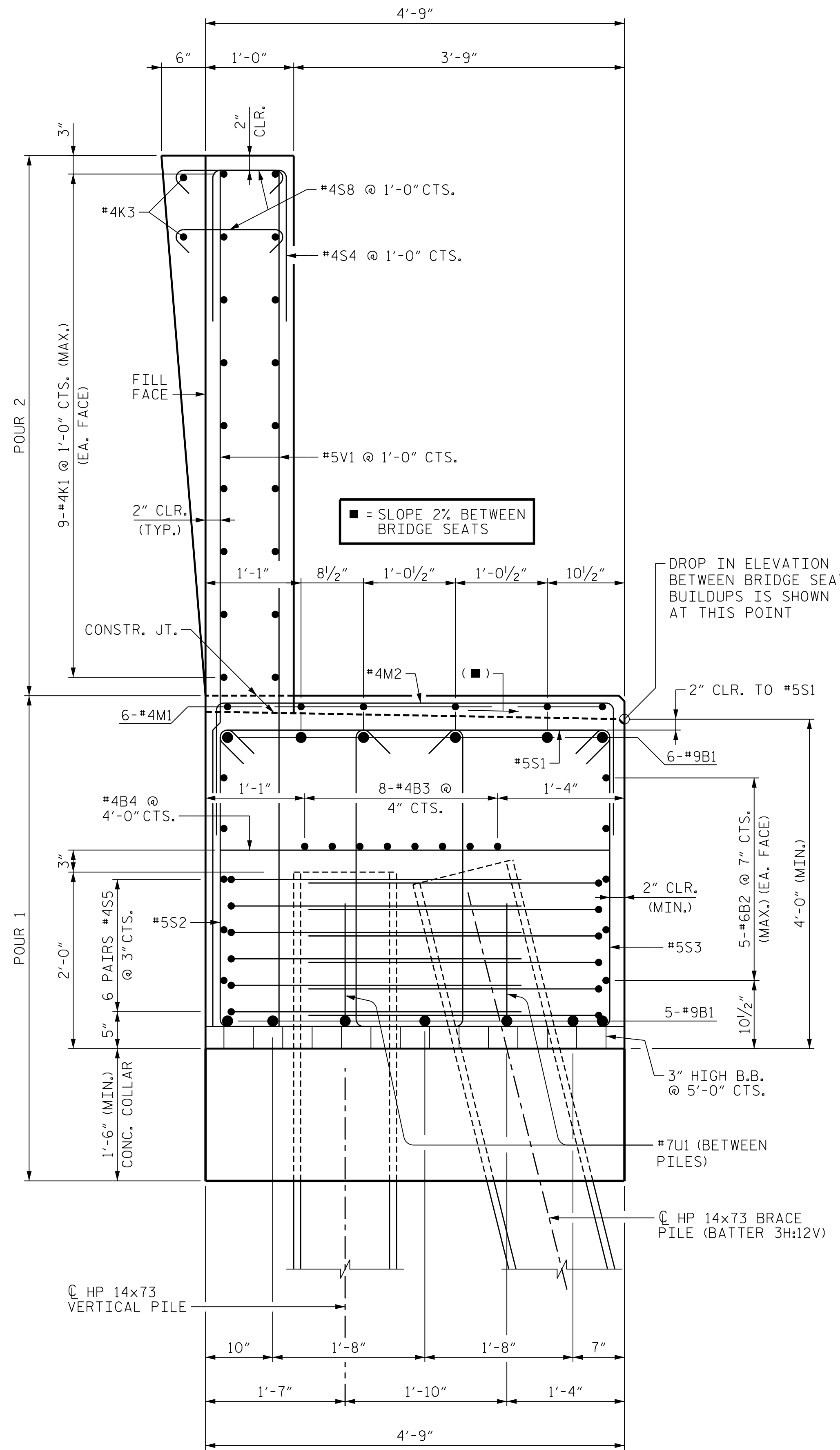

SECTION A-A

**NOTES:**  
 FOR PIPE INSERT DETAILS, SEE BEARING SHEETS.  
 THE TOP SURFACE AREAS OF THE END BENT CAP SHALL BE CURED IN ACCORDANCE WITH THE STANDARD SPECIFICATIONS EXCEPT THAT THE MEMBRANE CURING COMPOUND METHOD SHALL NOT BE USED.  
 BACKWALL SHALL BE PLACED BEFORE APPLYING THE EPOXY PROTECTIVE COATING.  
 THE TOP SURFACE OF THE END BENT CAP, EXCEPT THE BRIDGE SEAT BUILDUPS, SHALL BE SLOPED TRANSVERSELY FROM THE FILL FACE TO THE BACK FACE AT THE RATE OF 2%.  
 STIRRUPS IN CAP MAY BE SHIFTED AS NECESSARY TO CLEAR ANCHOR BOLTS.  
 SEE GENERAL DRAWING "FOUNDATION LAYOUT" FOR ADDITIONAL NOTES FOR DRIVING PILES.

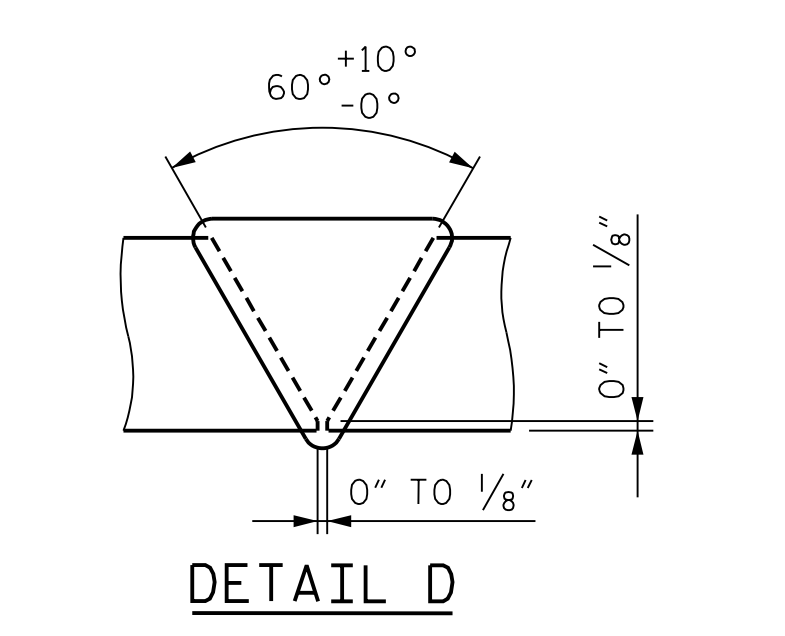
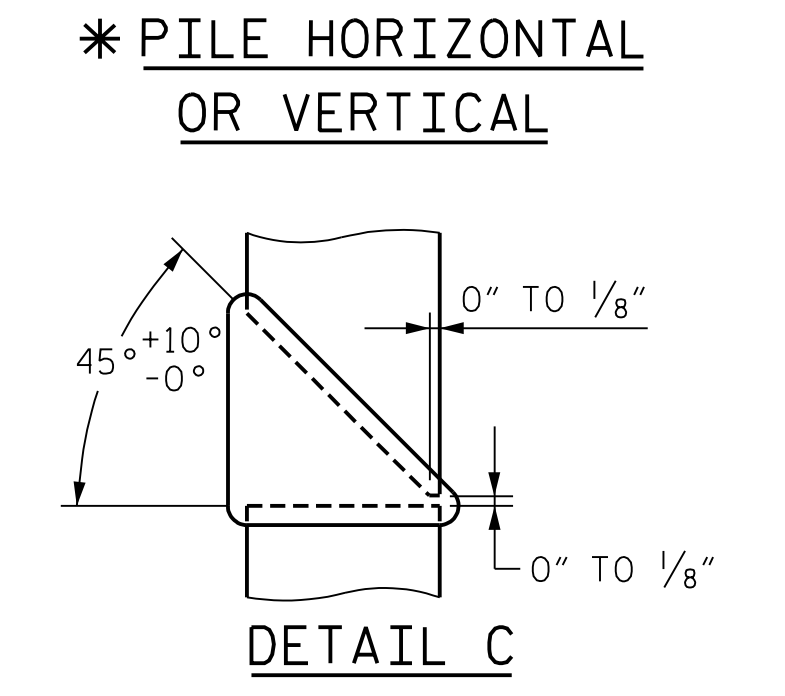
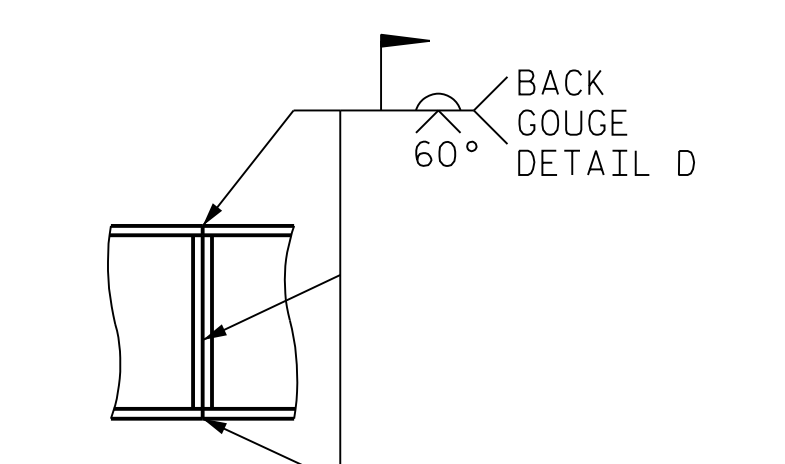
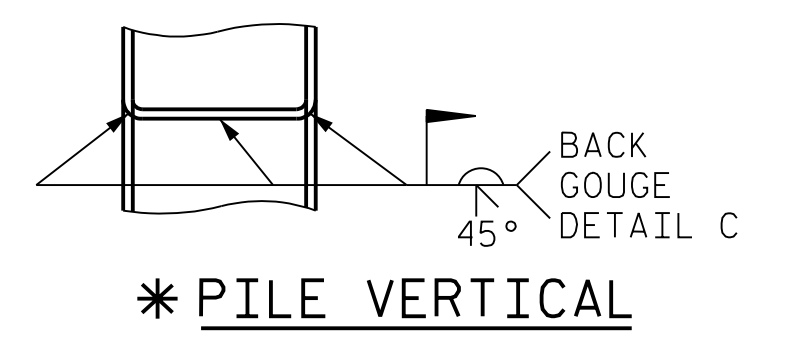

PILE SPLICE DETAILS  
 \* = POSITION OF PILE DURING WELDING

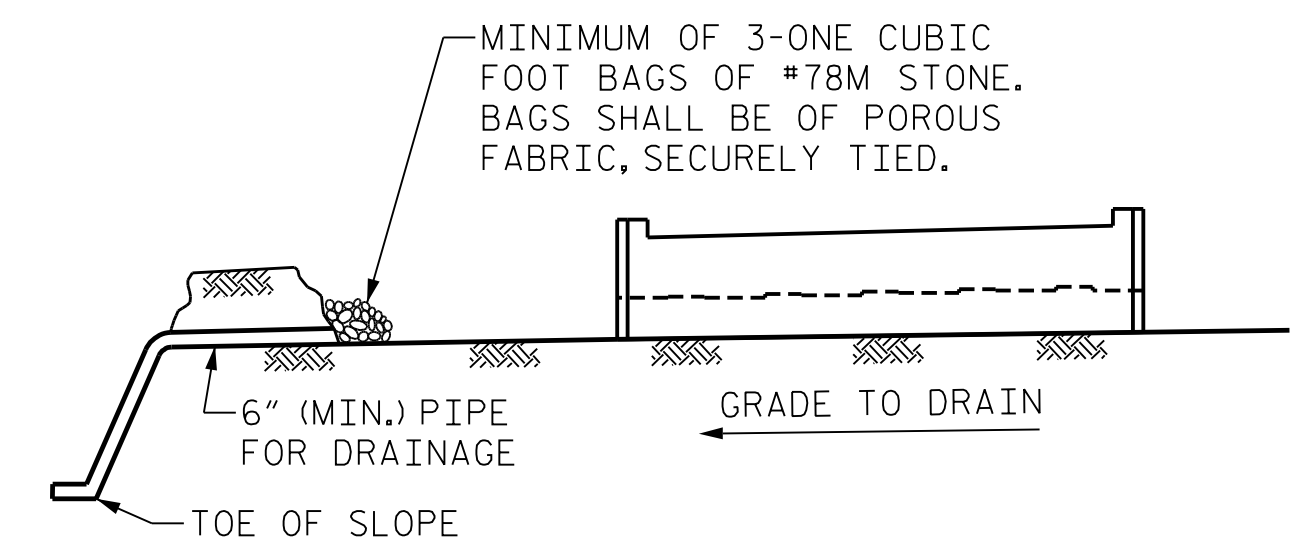

**NOTES:**  
 BAGGED STONE AND PIPE SHALL BE PLACED IMMEDIATELY AFTER COMPLETION OF END BENT EXCAVATION. PIPE MAY BE EITHER CONCRETE, CORRUGATED STEEL, CORRUGATED ALUMINUM ALLOY OR CORRUGATED PLASTIC. PERFORATED PIPE WILL NOT BE ALLOWED.  
 BAGGED STONE SHALL REMAIN IN PLACE UNTIL THE ENGINEER DIRECTS THAT IT BE REMOVED. THE CONTRACTOR SHALL REMOVE AND DISPOSE OF SILT ACCUMULATIONS AT BAGGED STONE WHEN SO DIRECTED BY THE ENGINEER. BAGS SHALL BE REMOVED AND REPLACED WHENEVER THE ENGINEER DETERMINES THAT THEY HAVE DETERIORATED AND LOST THEIR EFFECTIVENESS.  
 NO SEPARATE PAYMENT WILL BE MADE FOR THIS WORK AND THE ENTIRE COST OF THIS WORK SHALL BE INCLUDED IN THE UNIT CONTRACT PRICE FOR THE SEVERAL PAY ITEMS.

TEMPORARY DRAINAGE AT END BENT

**BAR TYPES**  
 (ALL DIMENSIONS ARE OUT TO OUT)

**BILL OF MATERIAL**

BAR NO.	SIZE	TYPE	LENGTH	WEIGHT
B1	#9	1	51'-3"	1,917
B2	#6	STR	48'-11"	735
B3	#4	STR	25'-8"	275
B4	#4	STR	4'-5"	39
H1	#5	5	26'-5"	662
H2	#5	5	22'-9"	1,329
K1	#4	STR	25'-9"	620
K2	#4	STR	2'-7"	14
K3	#4	STR	22'-9"	61
M1	#4	STR	2'-8"	43
M2	#4	4	7'-5"	60
S1	#5	2	5'-4"	279
S2	#5	3	10-10"	565
S3	#5	3	11'-0"	574
S4	#4	4	4'-2"	123
S5	#4	4	8'-6"	546
S6	#6	7	9'-1"	82
S7	#6	6	5'-5"	49
S8	#4	2	1'-9"	103
U1	#7	4	6'-6"	187
U2	#4	4	6'-5"	35
V1	#5	STR	12'-0"	1,102
V2	#5	STR	13'-9"	746
V3	#5	STR	13'-5"	728
REINFORCING STEEL				LBS. 10,874
CLASS "A" CONCRETE				
POUR 1: COLLAR, CAP, LOWER PART OF WINGS			CU. YDS.	47.6
POUR 2: BACKWALL & UPPER PART OF WINGS			CU. YDS.	35.7
TOTAL CONCRETE			CU. YDS.	83.3
HP 14x73 STEEL PILES				
			NO.	18
			LF	1,440
PILE DRIVING EQUIPMENT SETUP FOR HP 14x73 STEEL PILES			EA.	18



PROJECT NO. U-2579AB  
 FORSYTH COUNTY  
 STATION: 60+66.06 -Y15FLYAC-  
 SHEET 3 OF 3

STATE OF NORTH CAROLINA  
 DEPARTMENT OF TRANSPORTATION  
 RALEIGH

**SUBSTRUCTURE  
 END BENT 1  
 SECTION & DETAILS**

REVISIONS					
NO.	BY:	DATE:	NO.	BY:	DATE:
1	--	--	3	--	--
2	--	--	4	--	--

SHEET NO. S04-089  
 TOTAL SHEETS 144

PLOT DRIVER: NCDOT...  
 USER: PPETERSO  
 DATE: 10/14/2021  
 TIME: 4:04:52 PM  
 FILE: ...SUBSTR

DES BY: J. EARNEST	DATE: 07/19	DWG BY: B. PETERSON	DATE: 07/19
DES CHK: T. STOKES	DATE: 08/19	CHK BY: A. ZEITOUNI	DATE: 08/19

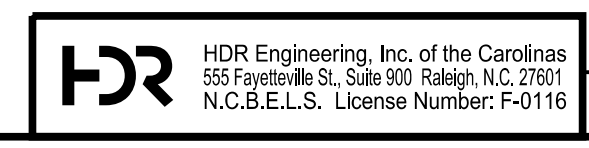

10/15/2021  
 DOCUMENT NOT CONSIDERED FINAL  
 UNLESS ALL SIGNATURES COMPLETED

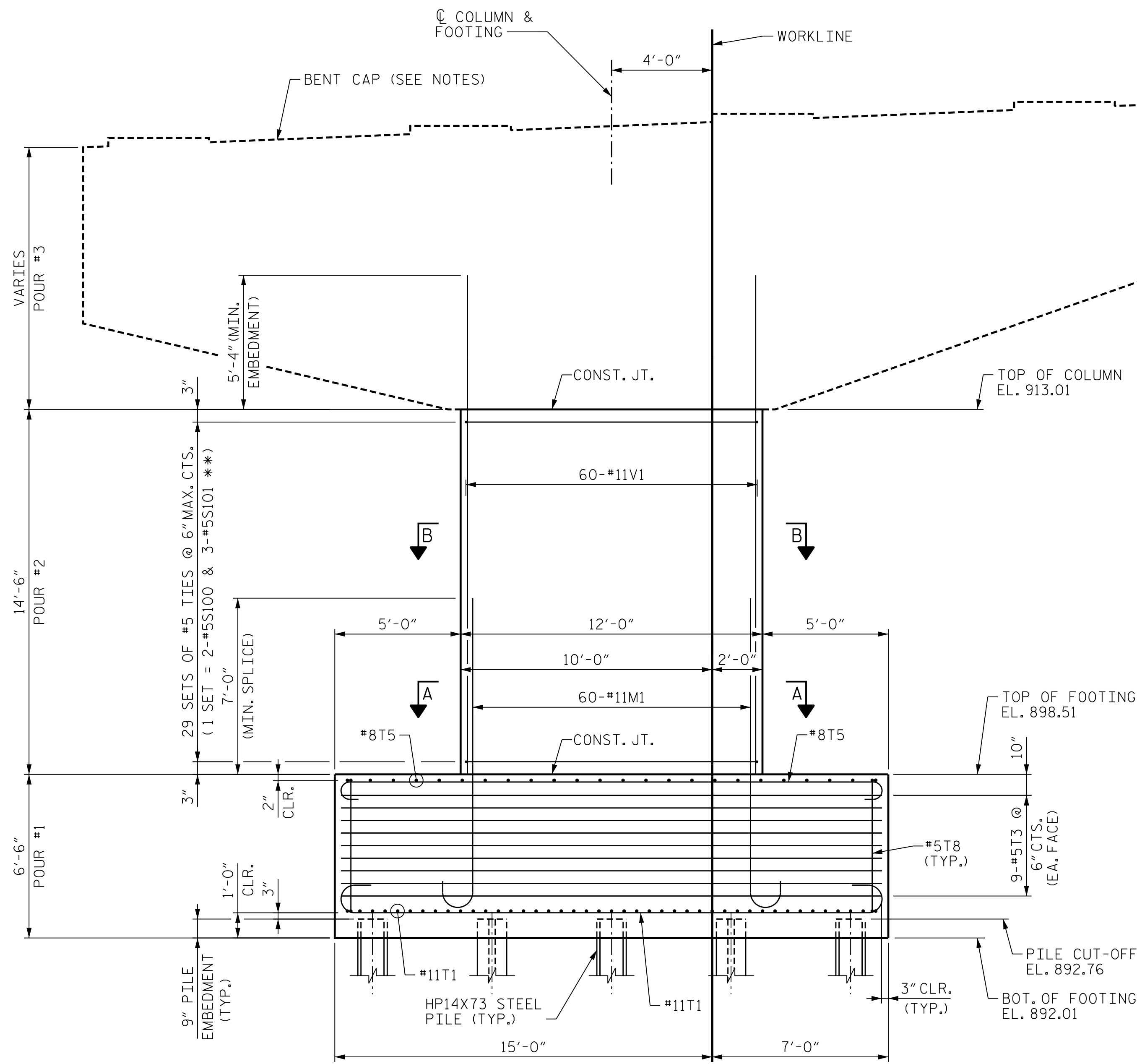

FRONT ELEVATION

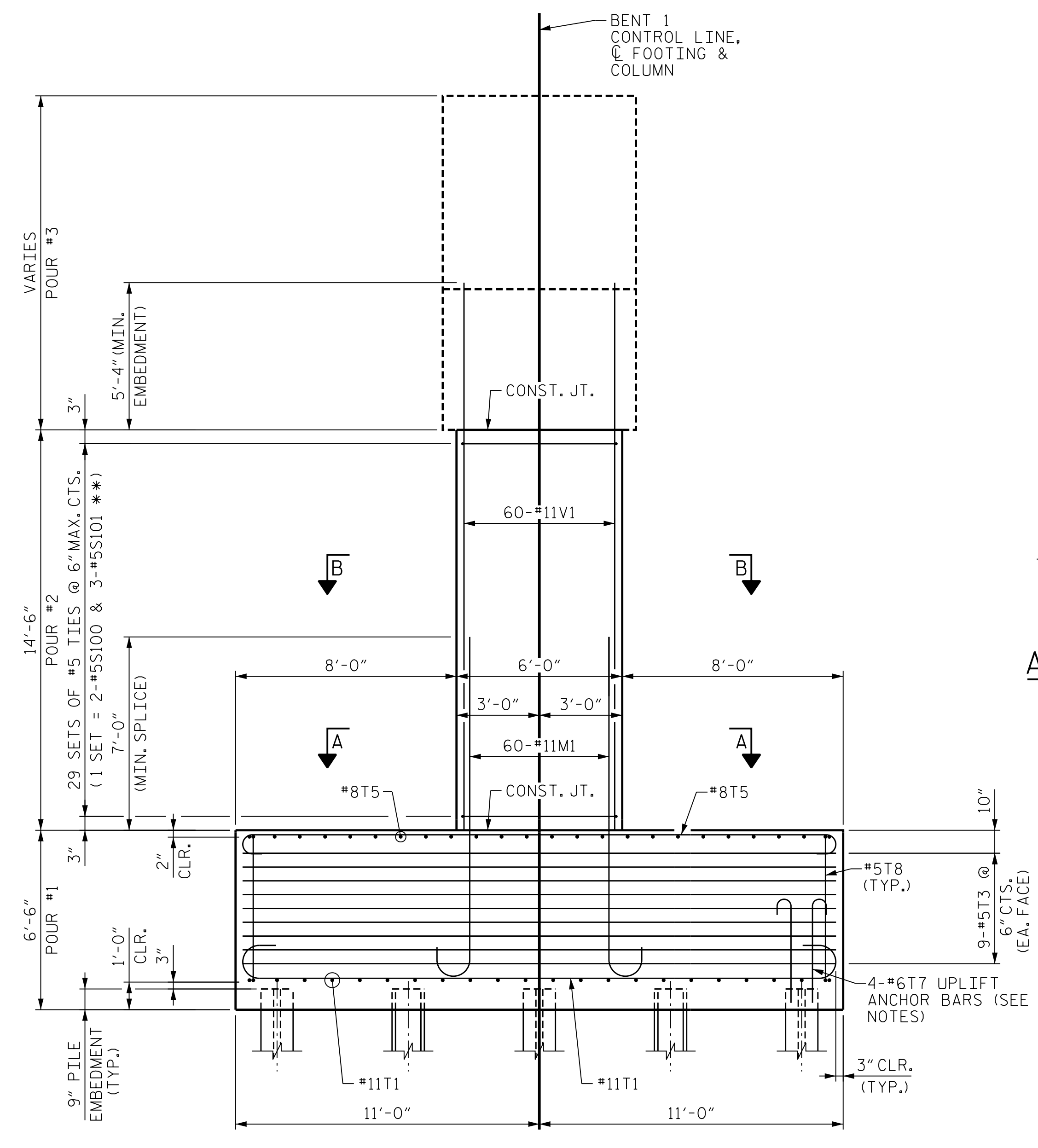

END ELEVATION

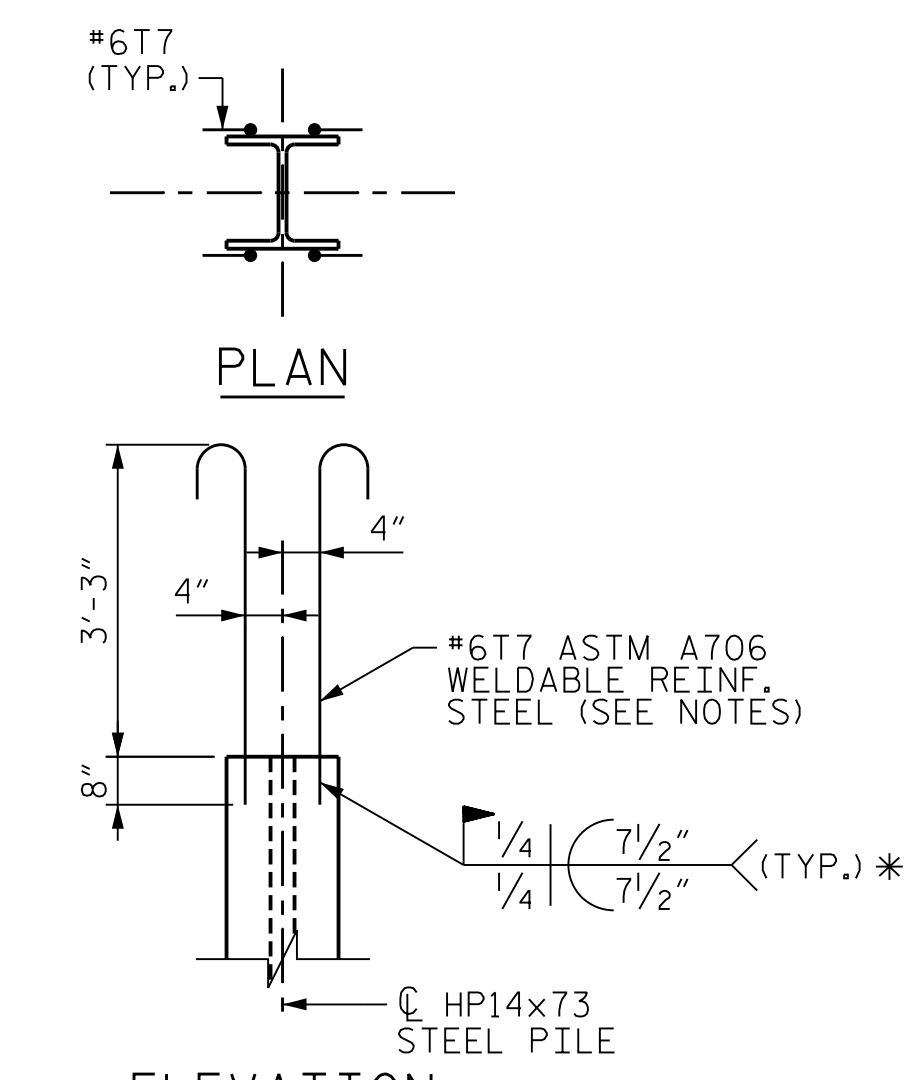

PILE UPLIFT ANCHOR DETAILS  
(TYP. AT PILES NOTED THUS: # ON SUBSTRUCTURE FOOTING & COLUMN DETAILS SHEET)

NOTES FOR BENTS 1 THROUGH 9

- HOOKS ON M1 AND T7 BARS MAY BE TURNED AS NECESSARY FOR PLACING REINFORCING STEEL.
- "T" BARS IN TOP OF FOOTING MAY BE SHIFTED AS NECESSARY, WITHOUT VIOLATING THE 1'-0" MAXIMUM SPACING, TO CLEAR M1 BARS EXTENDING INTO COLUMN.
- FOR MASS CONCRETE, SEE SPECIAL PROVISIONS.
- FOR PILE SPLICE DETAILS, SEE "SUBSTRUCTURE END BENT 1", SHEET 3 OF 3.

PLANS AND CALCULATIONS FOR ANY TEMPORARY SUPPORTS ATTACHED TO FOOTINGS, COLUMNS OR BENT CAPS SHALL BE SUBMITTED FOR REVIEW AND APPROVED BY THE ENGINEER PRIOR TO START OF BENT CONSTRUCTION. ANY ATTACHMENT PROVISIONS SHALL BE REMOVED AFTER USE AND THE FOOTINGS, COLUMNS OR BENT CAPS REPAIRED IN SUCH A WAY AS TO NOT COMPROMISE THE INTEGRITY OF THE BENT IN ANY WAY.

DETAILED DRAWINGS FOR FALSWORK AND FORMS FOR ALL HAMMERHEAD BENTS SHALL BE SUBMITTED. SEE SPECIAL PROVISIONS FOR FORMWORK AND FALSEWORK.

NOTES FOR BENT 1

- FOR DETAILS OF BENT CAP, SEE SHEET "SUBSTRUCTURE BENT 1 BENT CAP PLAN AND ELEVATION" AND SHEET "SUBSTRUCTURE BENT 1 BENT CAP DETAILS".
- FOR FOOTING PLAN, SECTION A-A AND SECTION B-B, SEE SHEET "SUBSTRUCTURE BENT 1 FOOTING & COLUMN DETAILS".
- 4-#6T7 UPLIFT ANCHOR BARS AT NOTED PILES - SEE SHEET "SUBSTRUCTURE BENT 1 FOOTING & COLUMN DETAILS" FOR LOCATIONS.

\*\* INVERT ORIENTATION OF ALTERNATE #5S101 TIES

PROJECT NO. U-2579AB  
 FORSYTH COUNTY  
 STATION: 60+66.06 -Y15FLYAC-

SHEET 1 OF 5

STATE OF NORTH CAROLINA  
 DEPARTMENT OF TRANSPORTATION  
 RALEIGH

**SUBSTRUCTURE BENT 1 ELEVATIONS**

REVISIONS					
NO.	BY:	DATE:	NO.	BY:	DATE:
1	--	--	3	--	--
2	--	--	4	--	--

SHEET NO. S04-090  
 TOTAL SHEETS 144



10/15/2021

PLOT DRIVER: NCDOT.pdf\_color\_eng-50.ppt  
 USER: PPETERSO DATE: 10/14/2021  
 FILE: ...SUBSTR

DES BY: J. CABABE	DATE: 10/19	DWG BY: B. PETERSON	DATE: 10/19
DES CHK: S. CHAUDHARI	DATE: 10/19	CHK BY: N. LIU	DATE: 11/19

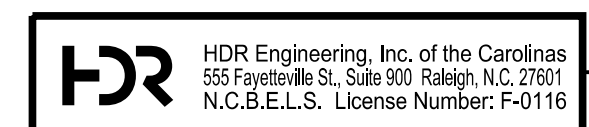

DOCUMENT NOT CONSIDERED FINAL UNLESS ALL SIGNATURES COMPLETED

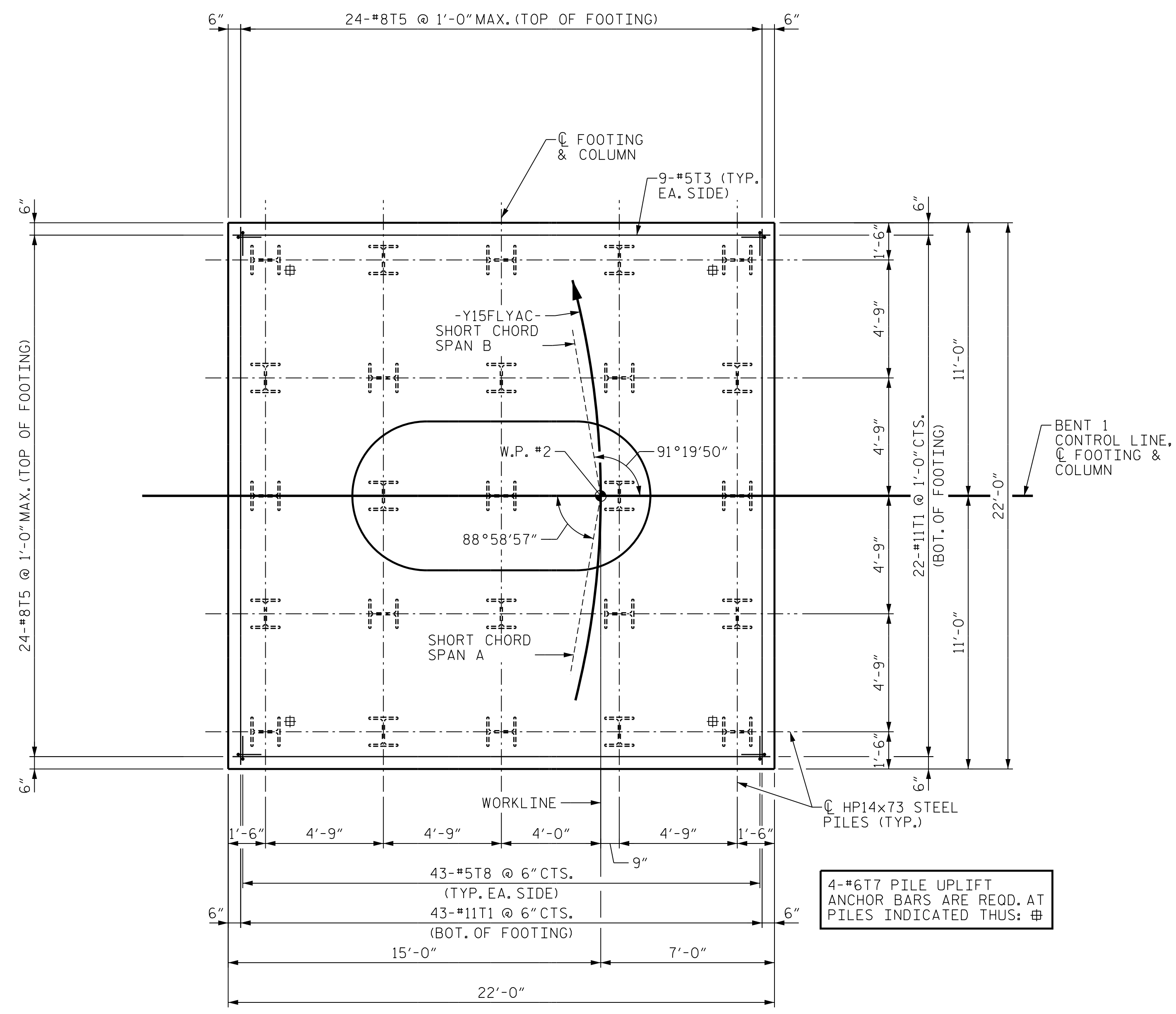

FOOTING PLAN

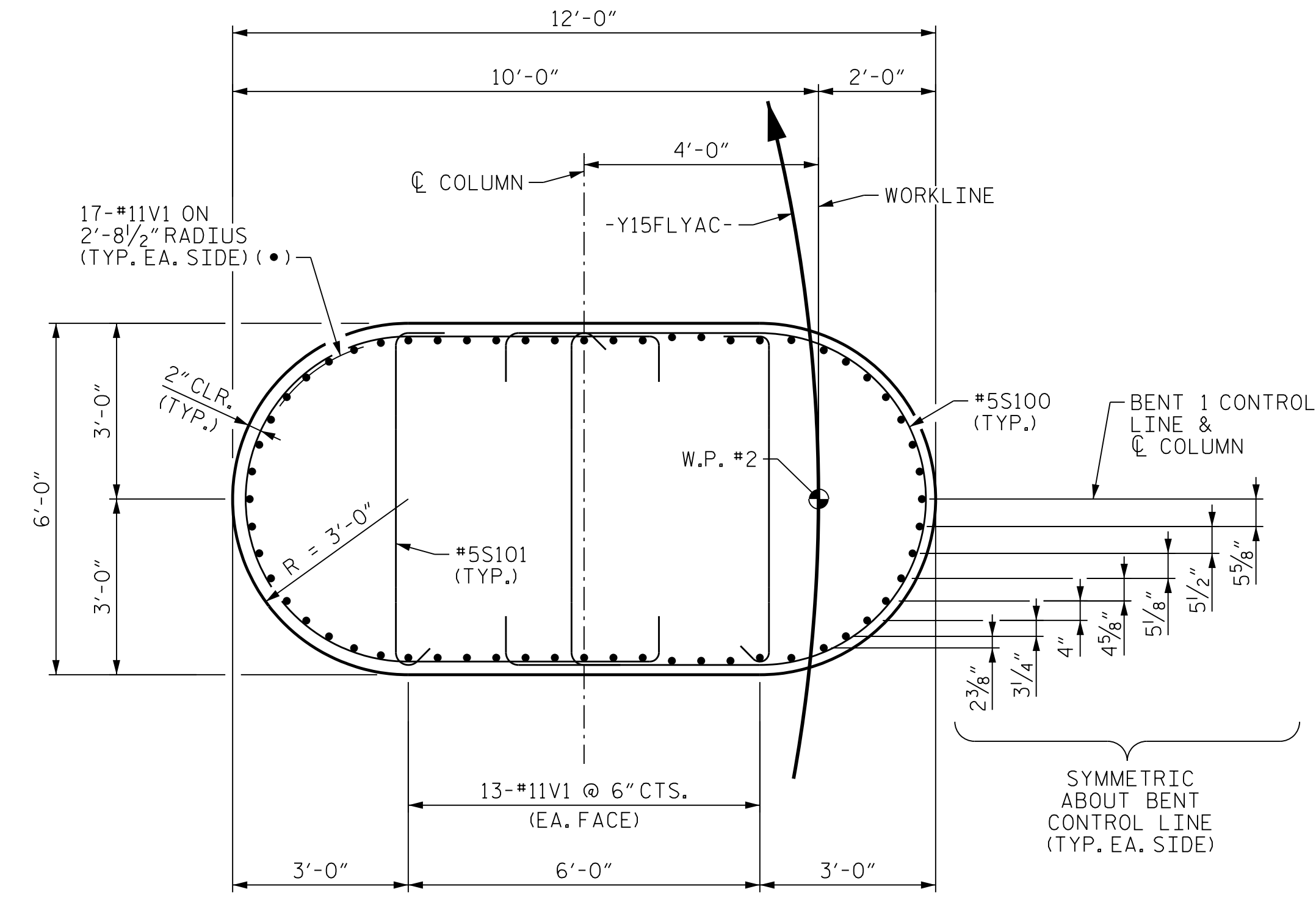

SECTION B-B

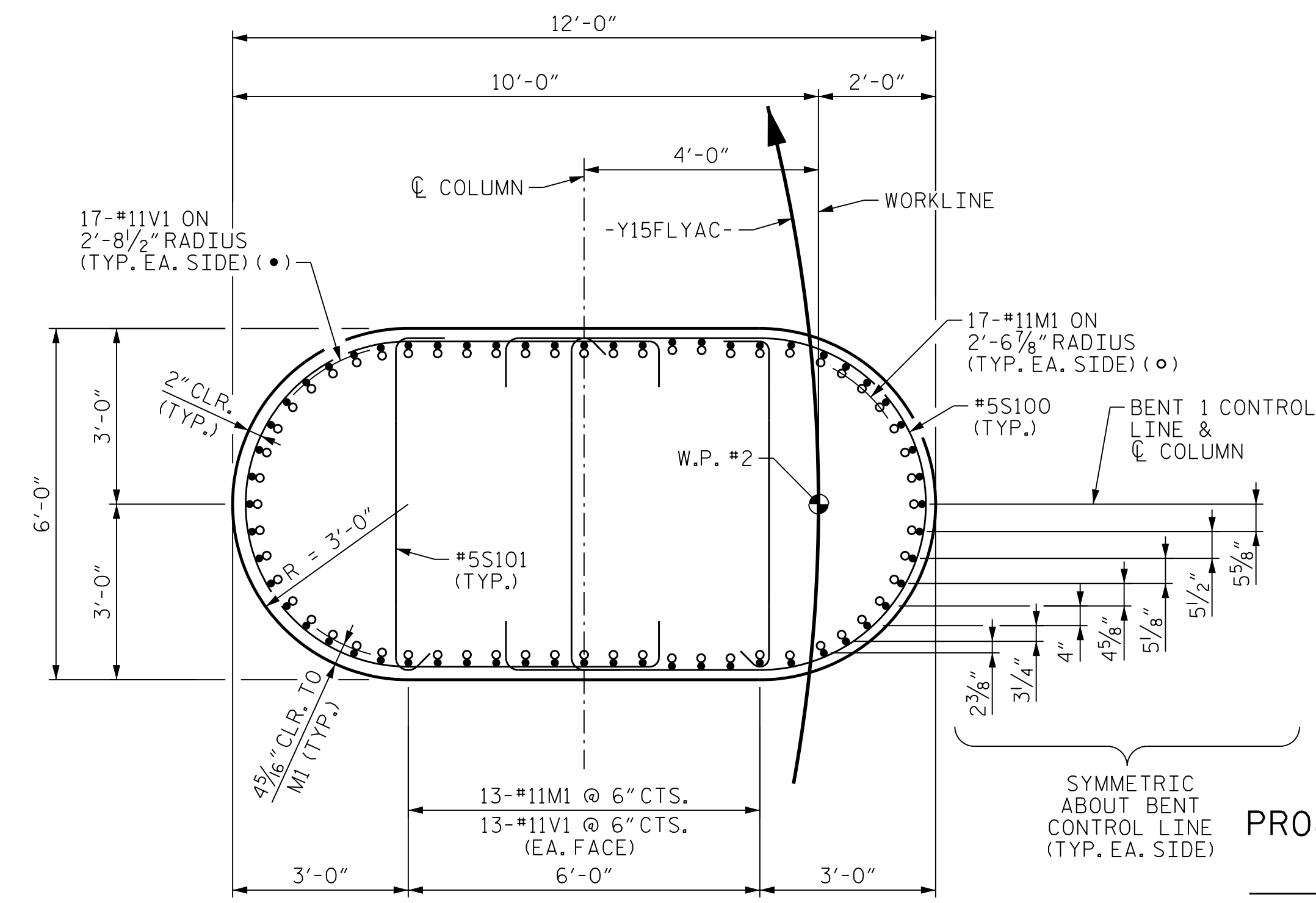

SECTION A-A

NOTE  
SEE SHEET 1 OF 5 FOR NOTES.

PROJECT NO. U-2579AB  
FORSYTH COUNTY  
STATION: 60+66.06 -Y15FLYAC-

SHEET 2 OF 5

STATE OF NORTH CAROLINA  
DEPARTMENT OF TRANSPORTATION  
RALEIGH

SUBSTRUCTURE  
BENT 1  
FOOTING & COLUMN  
DETAILS



10/15/2021

DES BY: J. CABABE	DATE: 10/19	DWG BY: B. PETERSON	DATE: 10/19
DES CHK: S. CHAUDHARI	DATE: 10/19	CHK BY: N. LIU	DATE: 11/19



DOCUMENT NOT CONSIDERED FINAL  
UNLESS ALL SIGNATURES COMPLETED

REVISIONS					
NO.	BY:	DATE:	NO.	BY:	DATE:
1	--	--	3	--	--
2	--	--	4	--	--

SHEET NO. S04-091
TOTAL SHEETS 144

PLOT DRIVER: NCDOT\_pdfs\_color\_eng-50dpi  
USER: PETERSON DATE: 10/14/2021  
FILE: ...SUBSTR

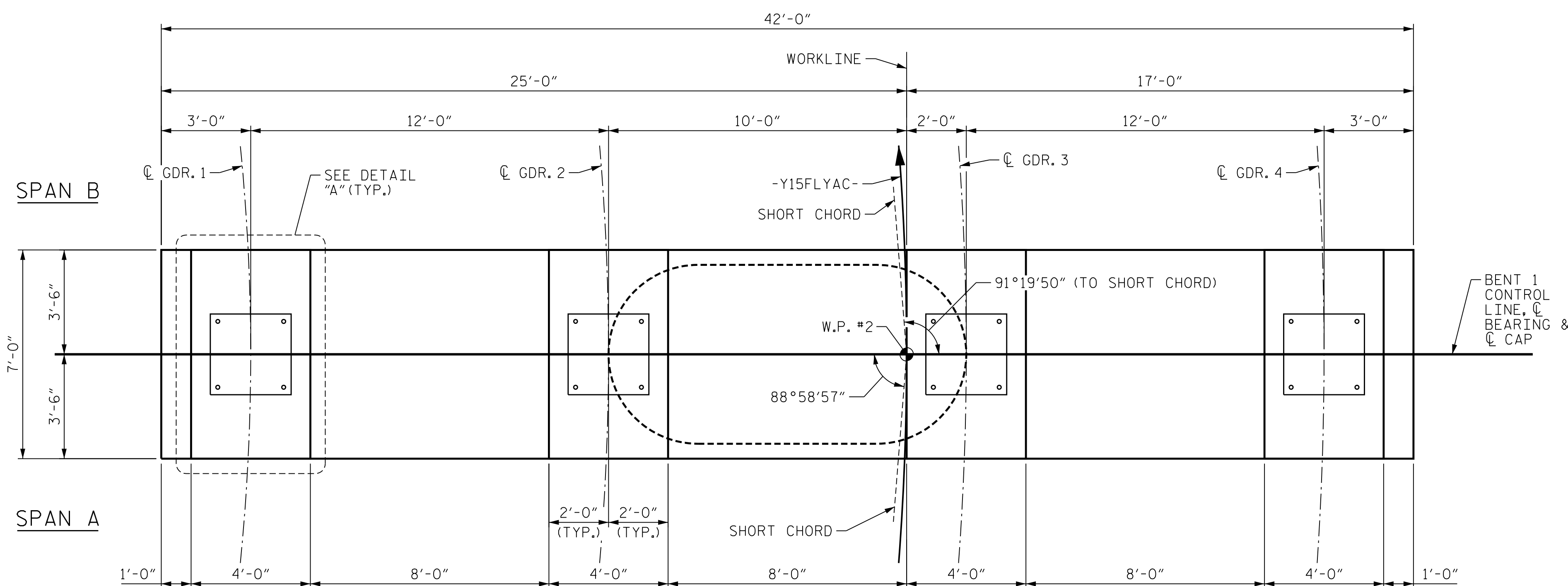

PLAN OF CAP

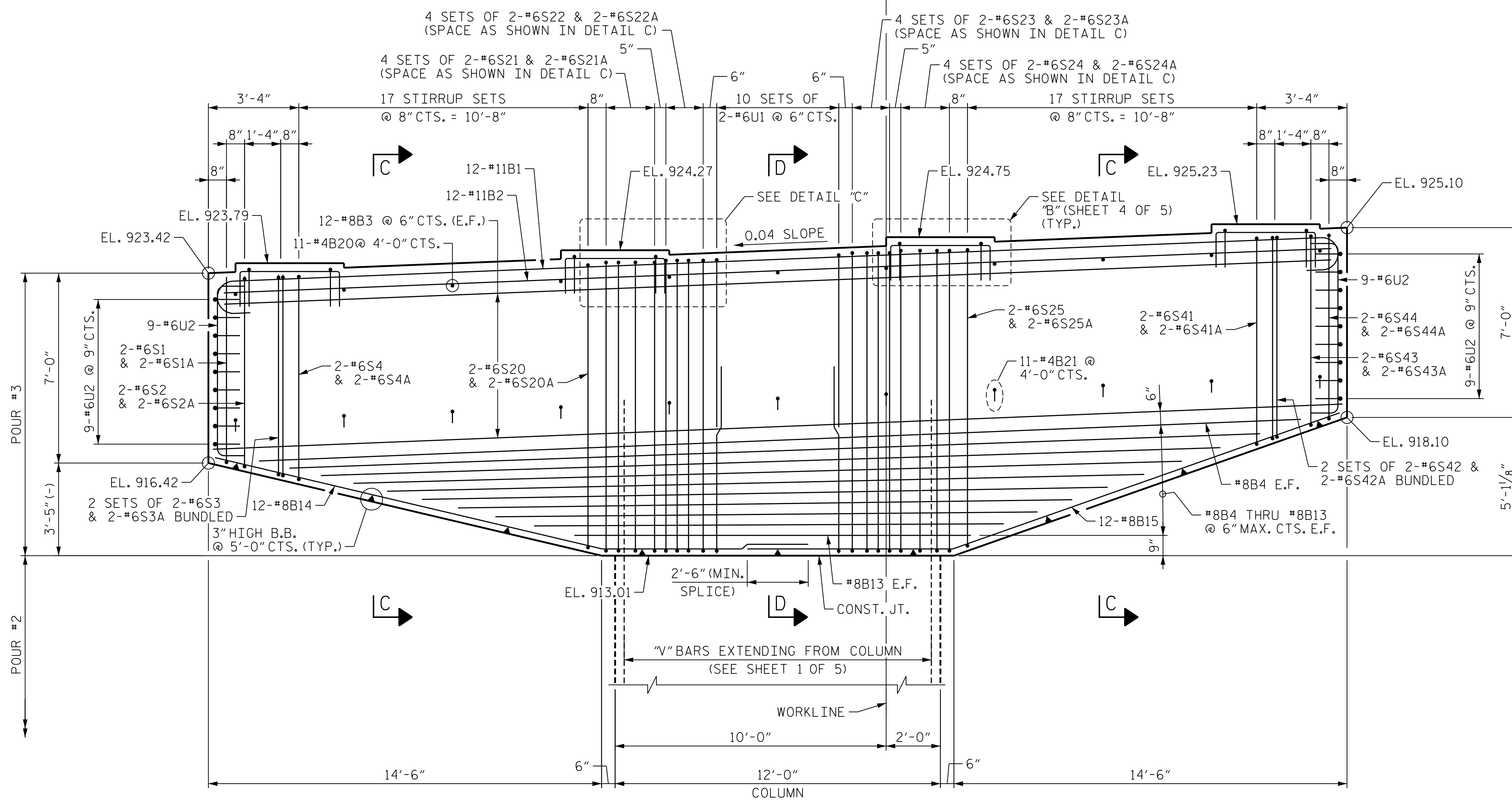

ELEVATION OF CAP

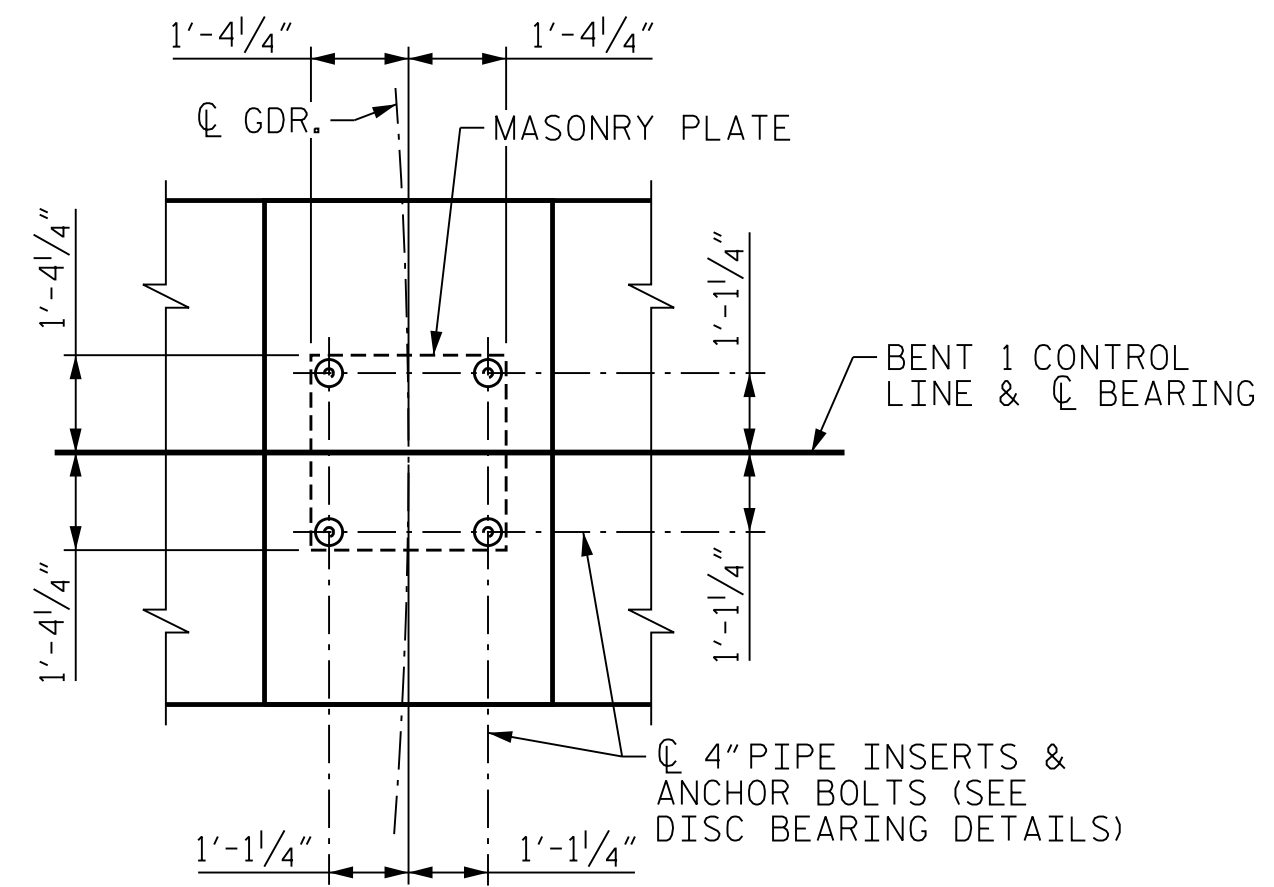

DETAIL "A"  
(TYP. @ EA. BEARING)

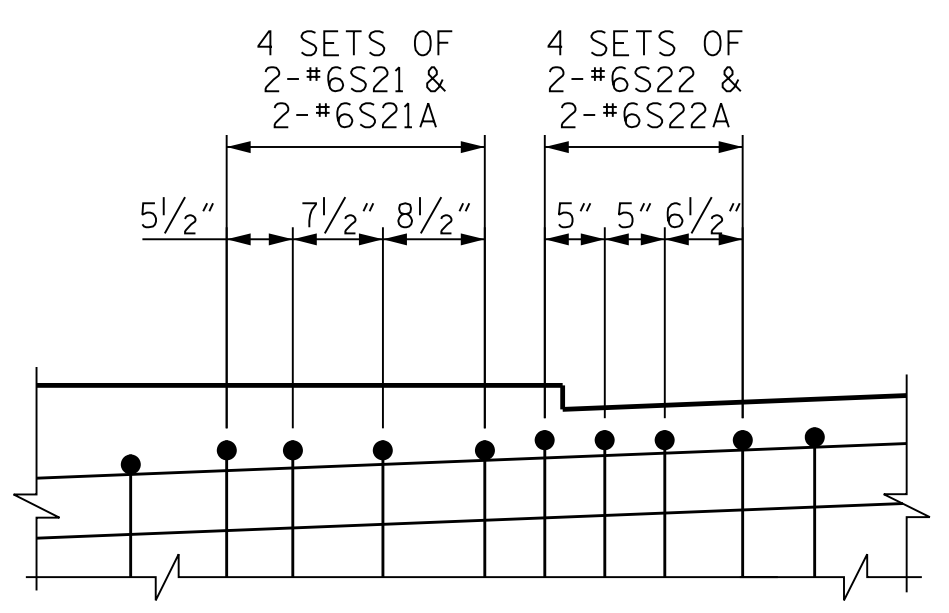

DETAIL "C"

DETAIL SHOWN AT LEFT SIDE OF CAP (SPACING OF STIRRUPS MIRRORRED AT RIGHT SIDE OF CAP WITH BARS #6S23/#6S23A AND #6S24/#6S24A AS SHOWN ON THE ELEVATION)

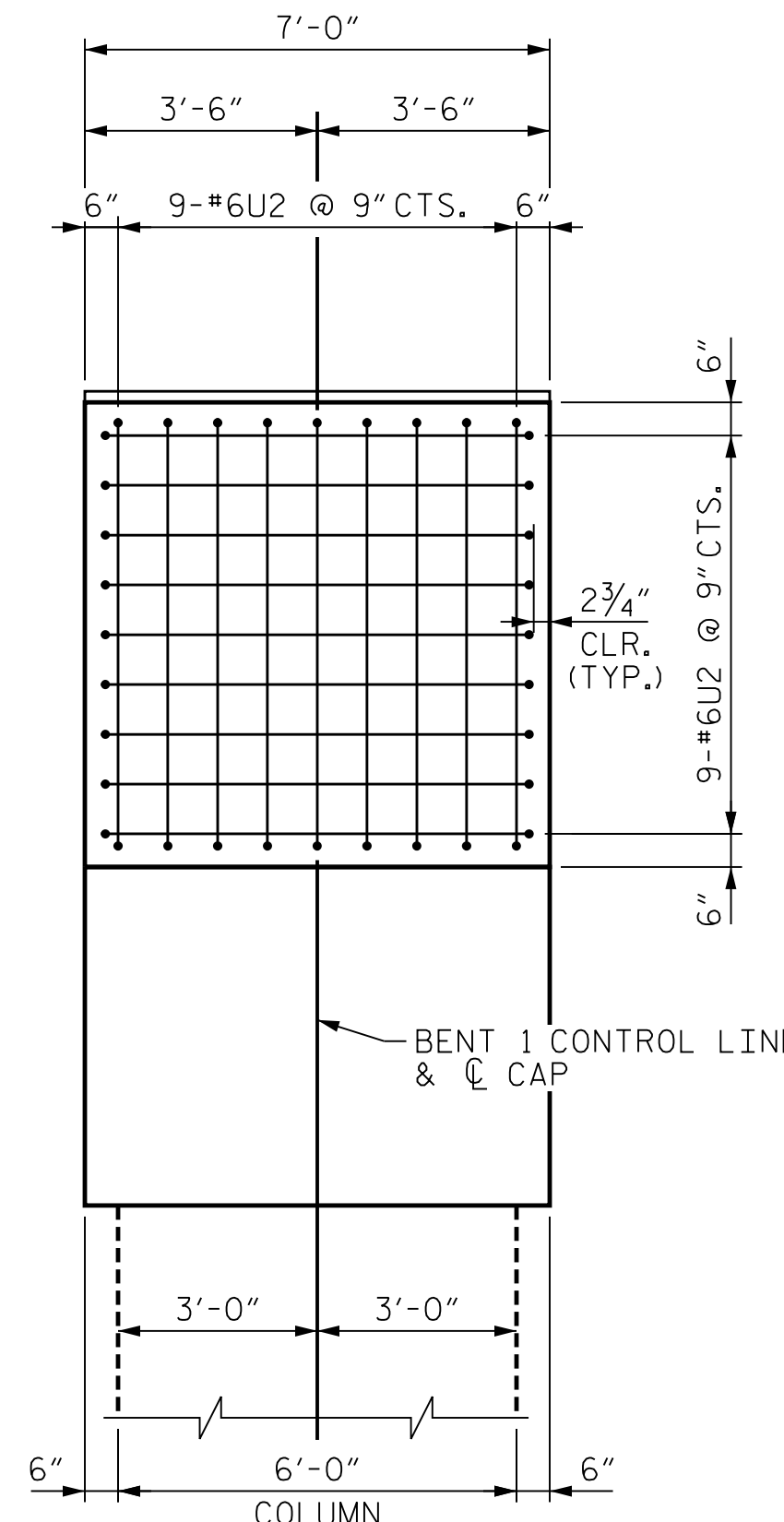

END VIEW

NOTES  
FOR SECTIONS C-C AND D-D, SEE "SUBSTRUCTURE BENT 1 BENT CAP DETAILS", SHEET 4 OF 5.  
FOR ADDITIONAL NOTES, SEE SHEET 1 OF 5.

PROJECT NO. U-2579AB  
FORSYTH COUNTY  
STATION: 60+66.06 -Y15FLYAC-  
SHEET 3 OF 5

STATE OF NORTH CAROLINA  
DEPARTMENT OF TRANSPORTATION  
RALEIGH

SUBSTRUCTURE  
BENT 1  
BENT CAP PLAN  
AND ELEVATION



10/15/2021

PLOT DRIVER: NCDOT\_pdf\_color\_eng-50dpi  
 USER: PPETERSO DATE: 10/14/2021 TIME: 4:05:16 PM  
 FILE: ...SUBSTR

DES BY: K. OLIVER	DATE: 10/19	DWG BY: B. PETERSON	DATE: 10/19
DES CHK: M. WERNER	DATE: 10/19	CHK BY: K. OLIVER	DATE: 11/19

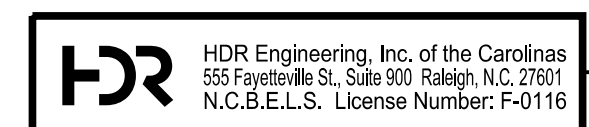

HDR Engineering, Inc. of the Carolinas  
555 Fayetteville St., Suite 900 Raleigh, N.C. 27601  
N.C.B.E.L.S. License Number: F-0116

DOCUMENT NOT CONSIDERED FINAL  
UNLESS ALL SIGNATURES COMPLETED

REVISIONS						SHEET NO. 504-092	
NO.	BY:	DATE:	NO.	BY:	DATE:	TOTAL SHEETS 144	
1	--	--	3	--	--		
2	--	--	4	--	--		



**NOTE**  
SEE SHEET 1 OF 5 FOR NOTES.

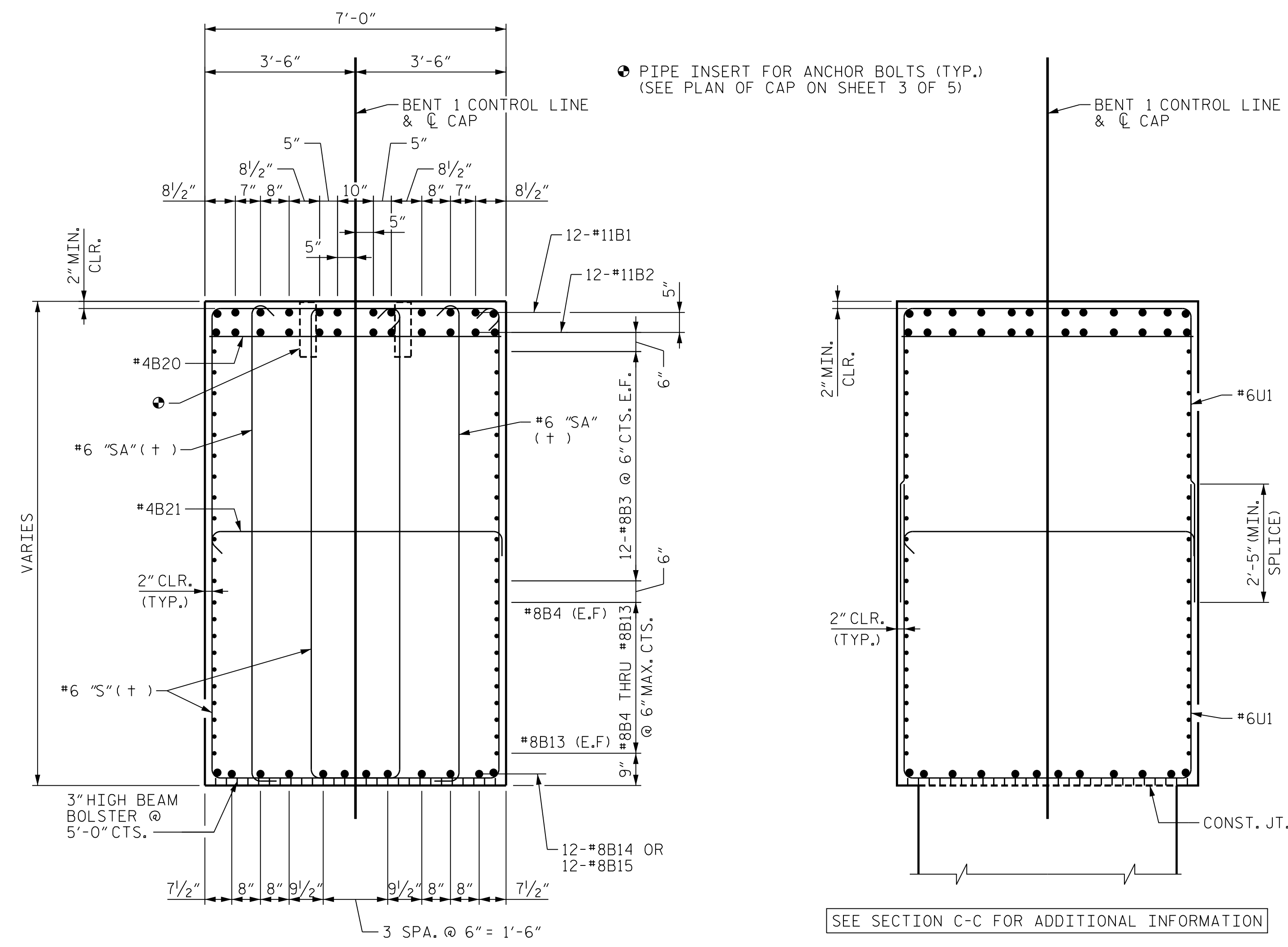

**SECTION C-C**  
(+) SEE "STIRRUP SET DETAIL"

SEE SECTION C-C FOR ADDITIONAL INFORMATION

**SECTION D-D**  
COLUMN REINFORCING STEEL NOT SHOWN FOR CLARITY

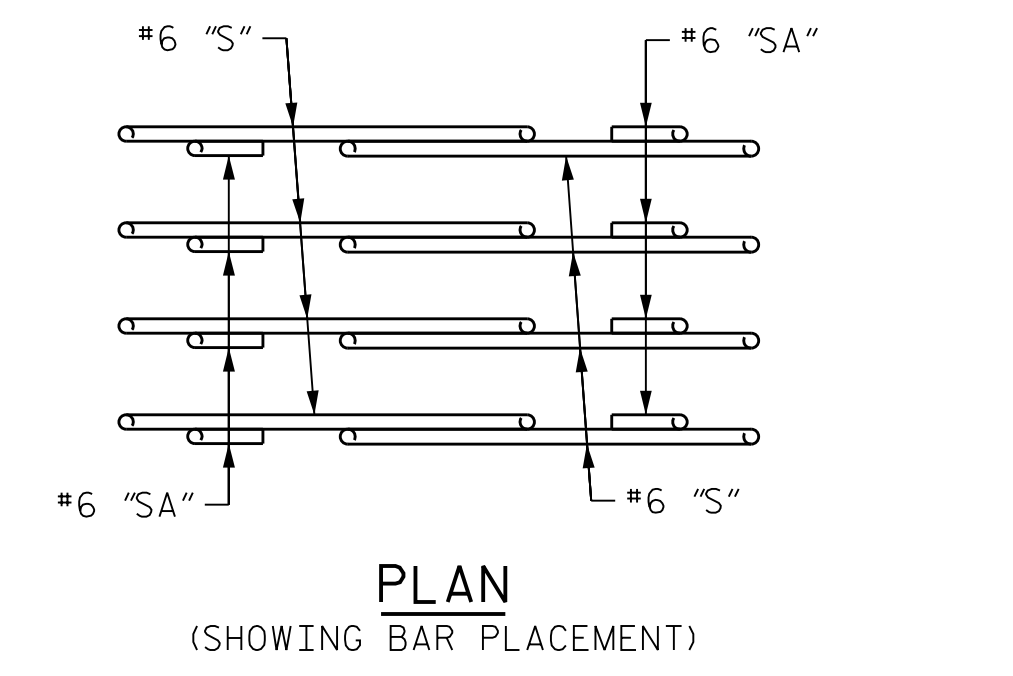

**PLAN**  
(SHOWING BAR PLACEMENT)

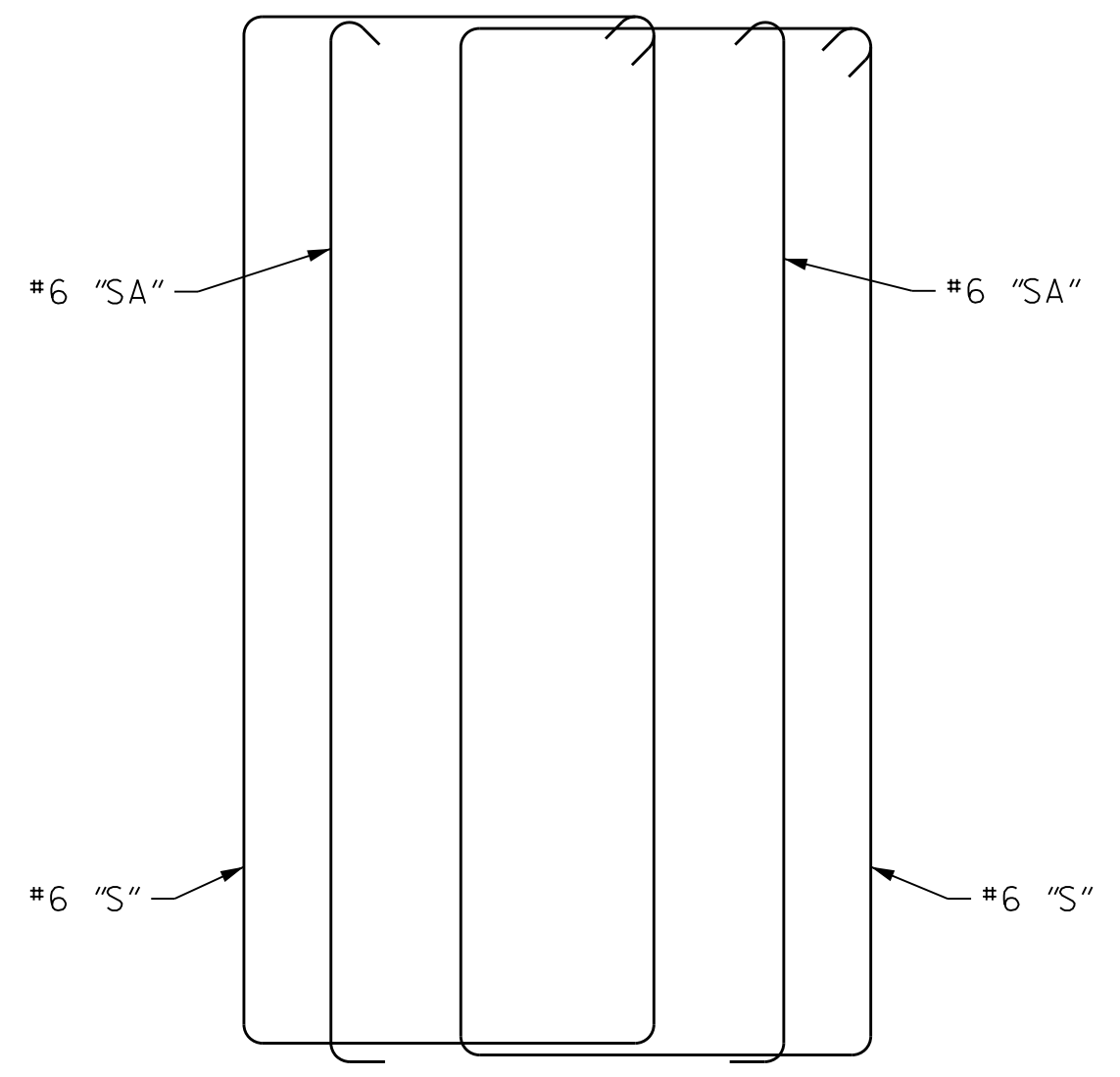

**ELEVATION**  
(SCHEMATIC)

**STIRRUP SET DETAIL**

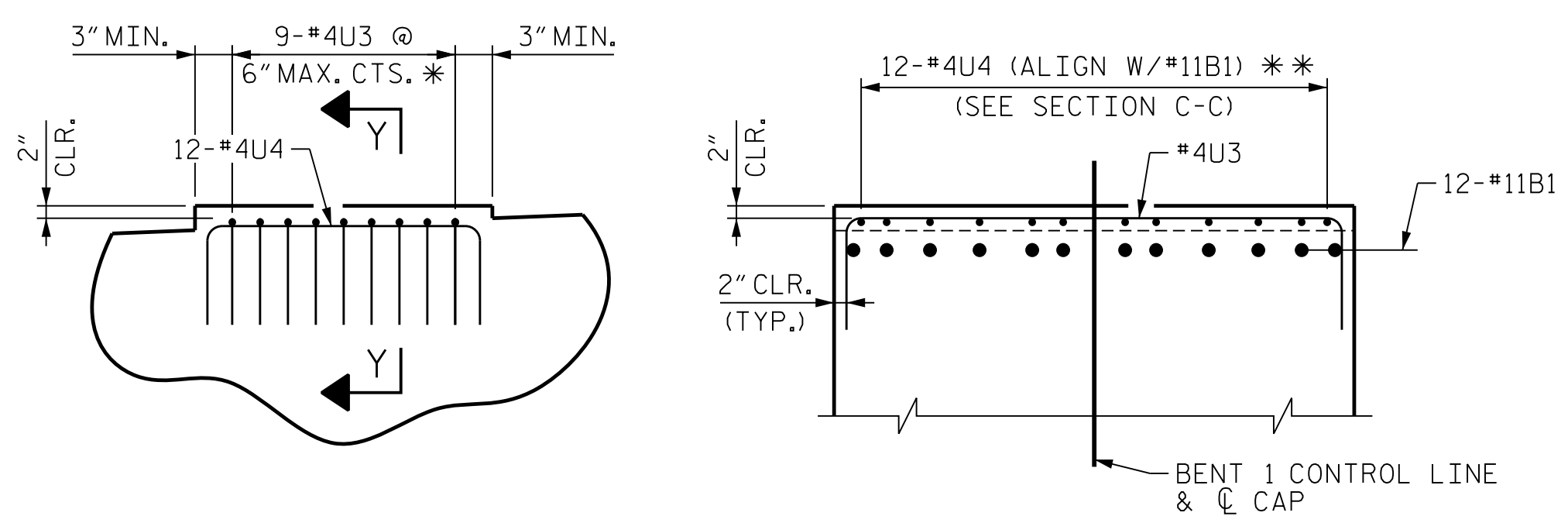

**DETAIL "B"**

**SECTION Y-Y**

\* NOTE:  
#4U3 BARS MAY BE SHIFTED SLIGHTLY AS NECESSARY TO CLEAR PIPE INSERTS FOR ANCHOR BOLTS.  
\*\* NOTE:  
#4U4 BARS MAY BE SHIFTED AS NECESSARY TO CLEAR #11B1 AND #11B2 BARS.

PROJECT NO. U-2579AB  
FORSYTH COUNTY  
STATION: 60+66.06 -Y15FLYAC-  
SHEET 4 OF 5

STATE OF NORTH CAROLINA  
DEPARTMENT OF TRANSPORTATION  
RALEIGH

**SUBSTRUCTURE  
BENT 1  
BENT CAP DETAILS**

REVISIONS					
NO.	BY:	DATE:	NO.	BY:	DATE:
1	--	--	3	--	--
2	--	--	4	--	--

SHEET NO. SO4-093  
TOTAL SHEETS 144



PLOT DRIVER: NCDOT\_pdf\_color\_eng-50dpi  
 USER: PETERSON DATE: 10/14/2021  
 FILE: ...SUBSTR  
 PENTABLE: NCDOT STRUCTURES DEFAULT PEN.tbl  
 TIME: 4:05:41 PM

DES BY: K. OLIVER DATE: 10/19 DWG BY: B. PETERSON DATE: 10/19  
 DES CHK: M. WERNER DATE: 10/19 CHK BY: K. OLIVER DATE: 11/19

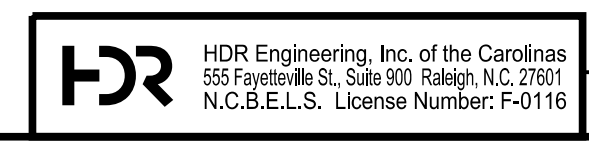

**DOCUMENT NOT CONSIDERED FINAL  
UNLESS ALL SIGNATURES COMPLETED**



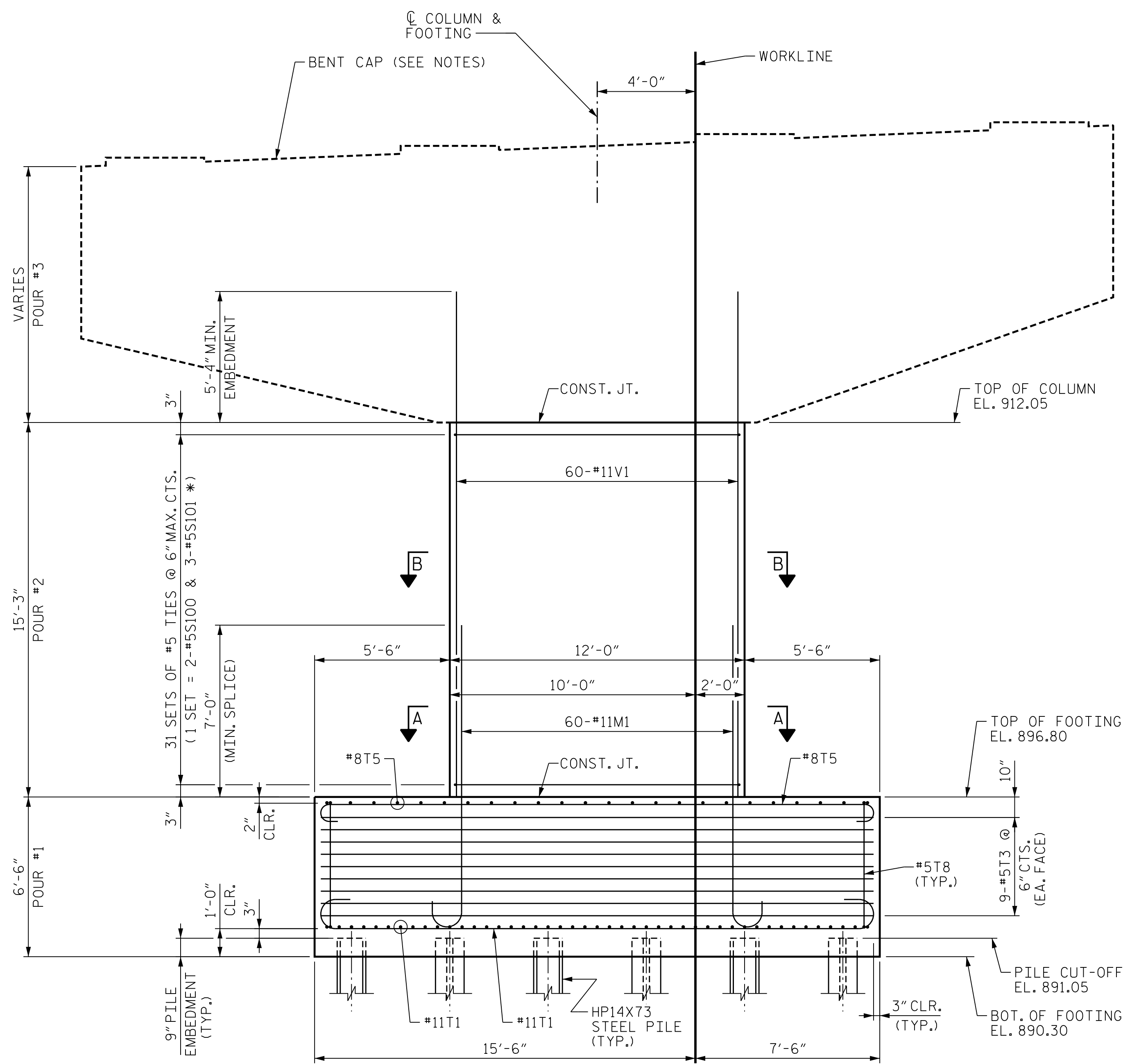

FRONT ELEVATION

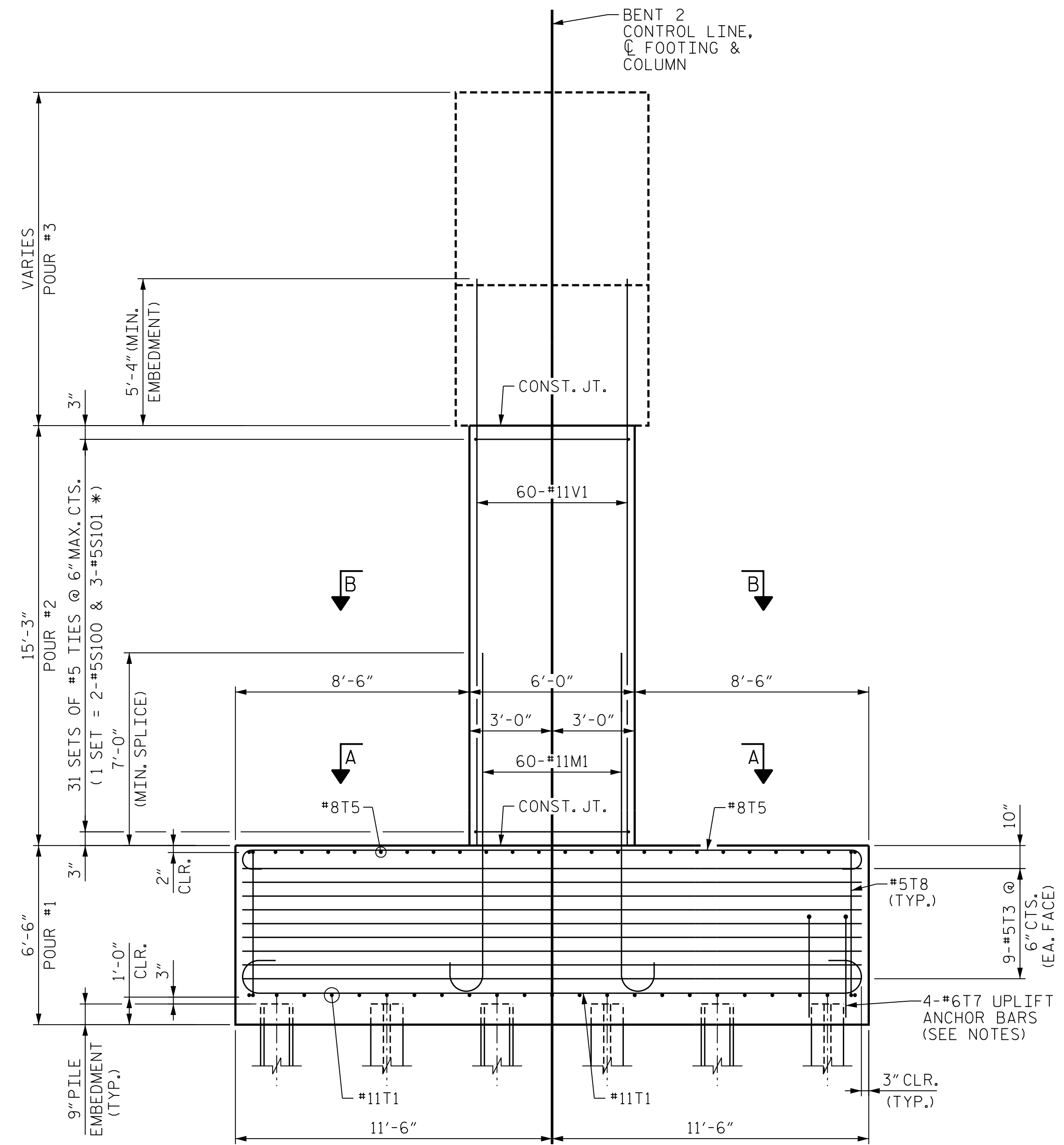

END ELEVATION

**NOTES**

FOR FOOTING PLAN, SECTION A-A AND SECTION B-B, SEE SHEET "SUBSTRUCTURE BENT 2 FOOTING & COLUMN DETAILS".

FOR DETAILS OF BENT 2 BENT CAP, SEE SHEET "SUBSTRUCTURE BENT 2 BENT CAP PLAN AND ELEVATION" AND SHEET "SUBSTRUCTURE BENT 2 BENT CAP DETAILS".

4-#6T7 UPLIFT ANCHOR BARS AT NOTED PILES - SEE SHEET "SUBSTRUCTURE BENT 2 FOOTING & COLUMN DETAILS" FOR LOCATIONS.

SEE SHEET "SUBSTRUCTURE BENT 1 ELEVATIONS" FOR ADDITIONAL NOTES AND PILE UPLIFT ANCHOR DETAIL.

\* INVERT ORIENTATION OF ALTERNATE #5S101 TIES

PROJECT NO. U-2579AB  
 FORSYTH COUNTY  
 STATION: 60+66.06 -Y15FLYAC-  
 SHEET 1 OF 5

STATE OF NORTH CAROLINA  
 DEPARTMENT OF TRANSPORTATION  
 RALEIGH

**SUBSTRUCTURE BENT 2 ELEVATIONS**



REVISIONS					
NO.	BY:	DATE:	NO.	BY:	DATE:
1	--	--	3	--	--
2	--	--	4	--	--

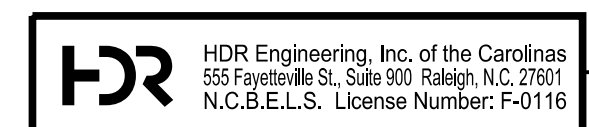

DOCUMENT NOT CONSIDERED FINAL  
 UNLESS ALL SIGNATURES COMPLETED

PLOT DRIVER: NCDOT... PENTABLE: NCDOT... STRUCTURES DEFAULT PEN.tbl  
 USER: PPETERSO DATE: 10/14/2021 TIME: 4:05:58 PM  
 FILE: ...SUBSTR

DES BY: J. CABABE	DATE: 10/19	DWG BY: B. PETERSON	DATE: 10/19
DES CHK: S. CHAUDHARI	DATE: 10/19	CHK BY: N. LIU	DATE: 11/19

SHEET NO. S04-095  
 TOTAL SHEETS 144

**NOTE**  
SEE SHEET 1 OF 5 FOR NOTES.

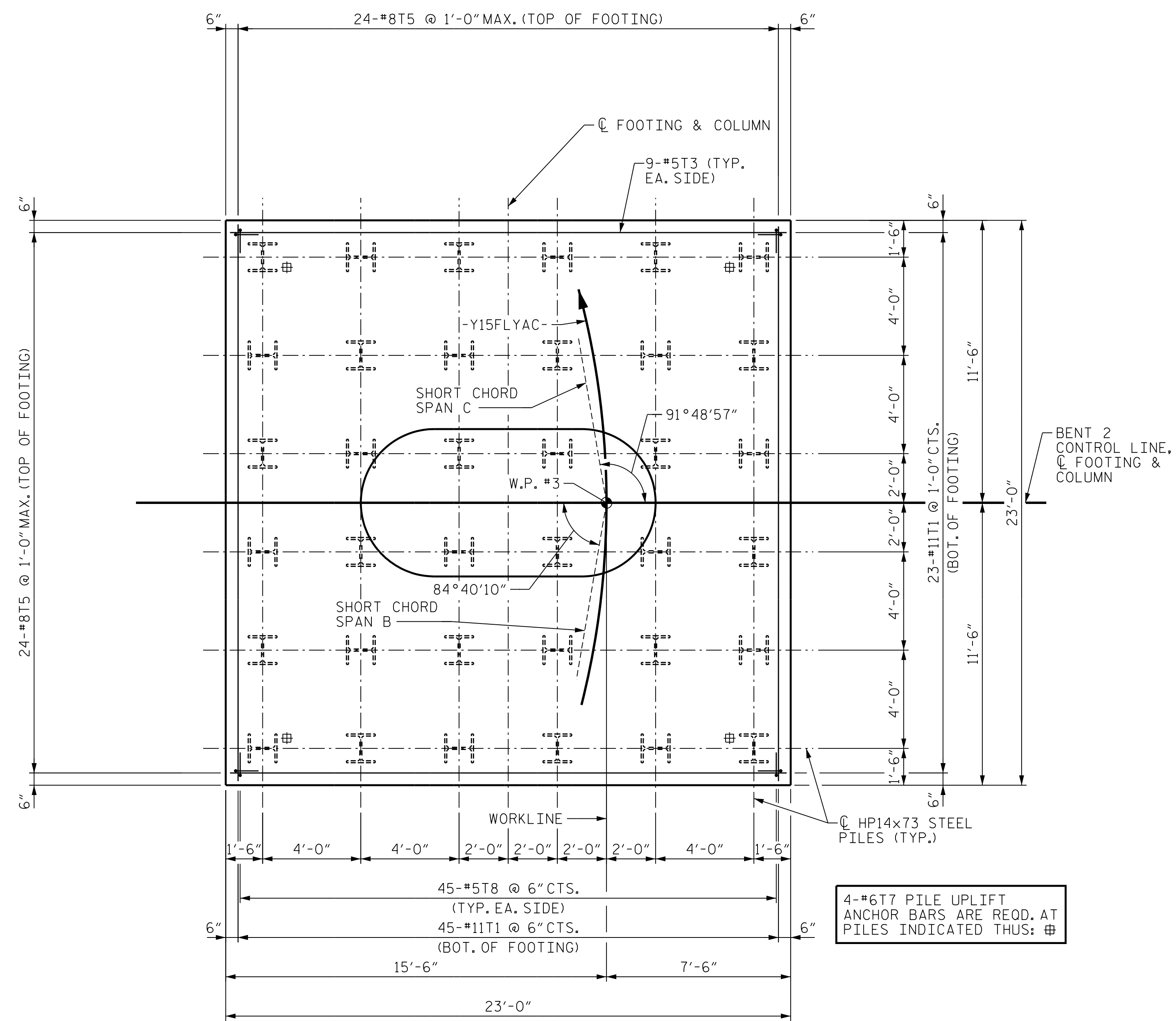

**FOOTING PLAN**

4-#6T7 PILE UPLIFT ANCHOR BARS ARE REOD. AT PILES INDICATED THUS: #

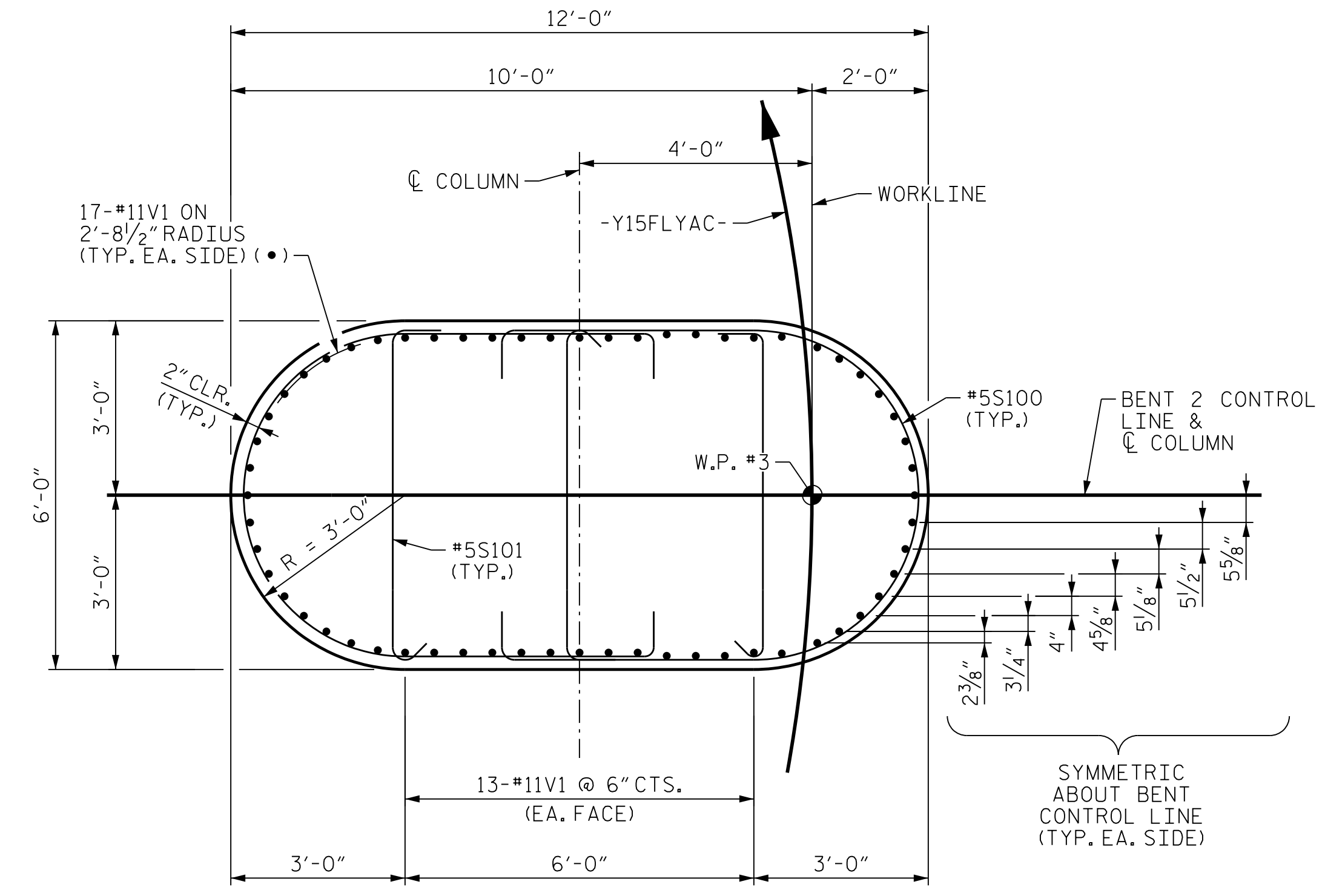

**SECTION B-B**

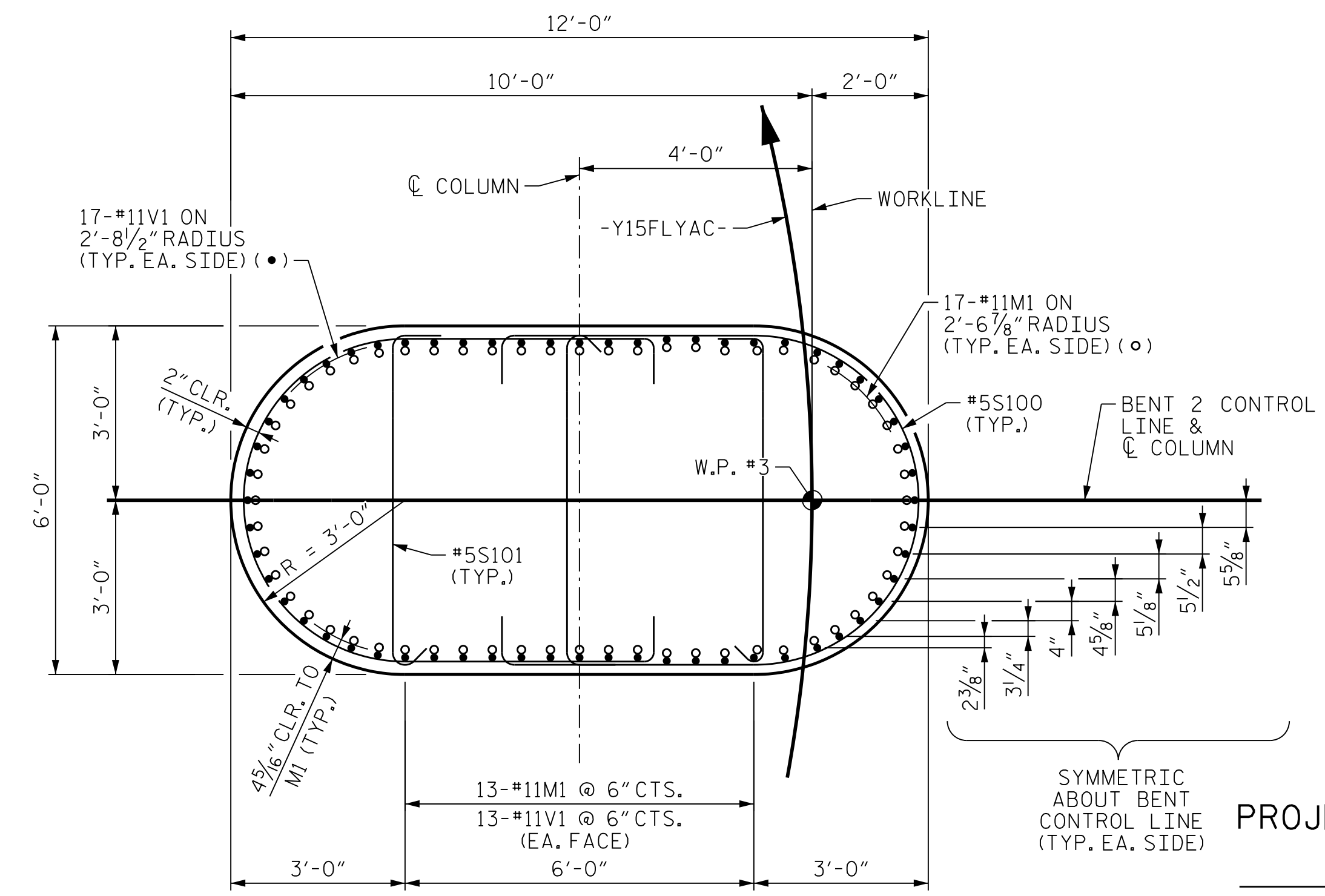

**SECTION A-A**

PROJECT NO. U-2579AB  
FORSYTH COUNTY  
 STATION: 60+66.06 -Y15FLYAC-

SHEET 2 OF 5

STATE OF NORTH CAROLINA  
 DEPARTMENT OF TRANSPORTATION  
 RALEIGH

**SUBSTRUCTURE  
 BENT 2  
 FOOTING & COLUMN  
 DETAILS**



10/15/2021

DES BY: J. CABABE	DATE: 10/19	DWG BY: B. PETERSON	DATE: 10/19
DES CHK: S. CHAUDHARI	DATE: 10/19	CHK BY: N. LIU	DATE: 11/19



DOCUMENT NOT CONSIDERED FINAL  
 UNLESS ALL SIGNATURES COMPLETED

REVISIONS					
NO.	BY:	DATE:	NO.	BY:	DATE:
1	--	--	3	--	--
2	--	--	4	--	--

SHEET NO. S04-096  
 TOTAL SHEETS 144

PLOT DRIVER: NCDOT.pdf\_color\_eng-50dpi  
 USER: PPETERSO DATE: 10/14/2021  
 FILE: ...SUBSTR

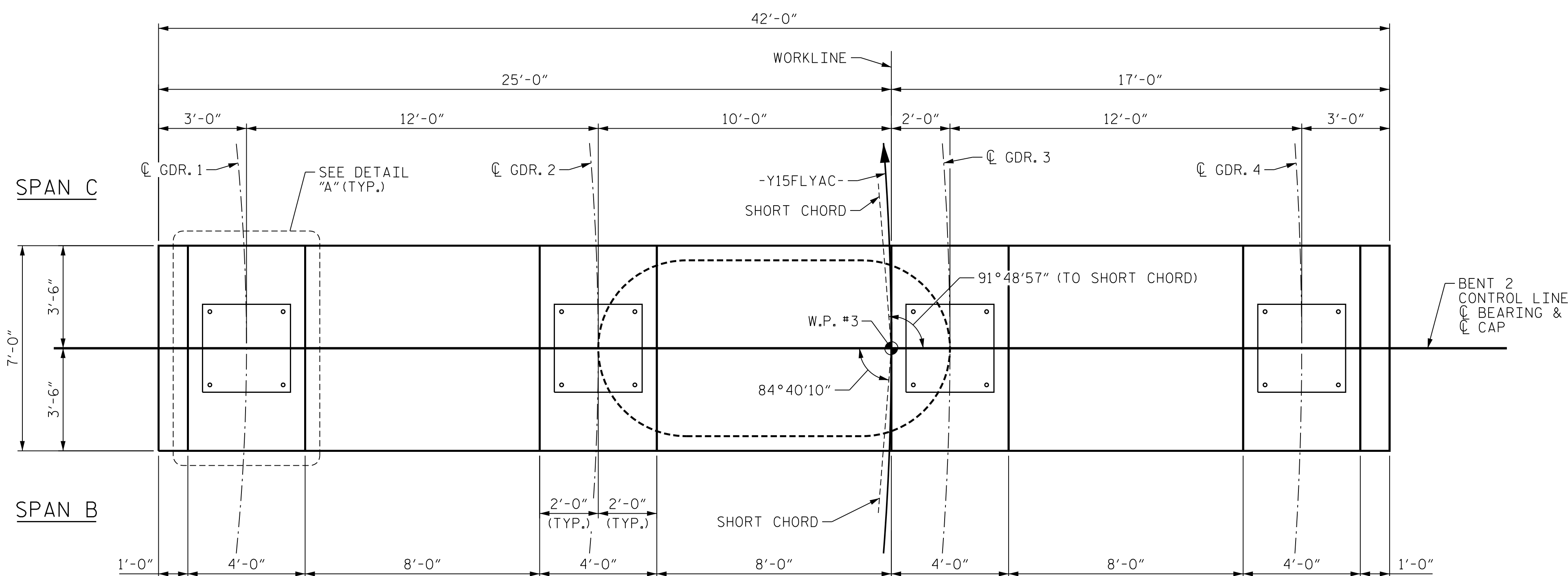

PLAN OF CAP

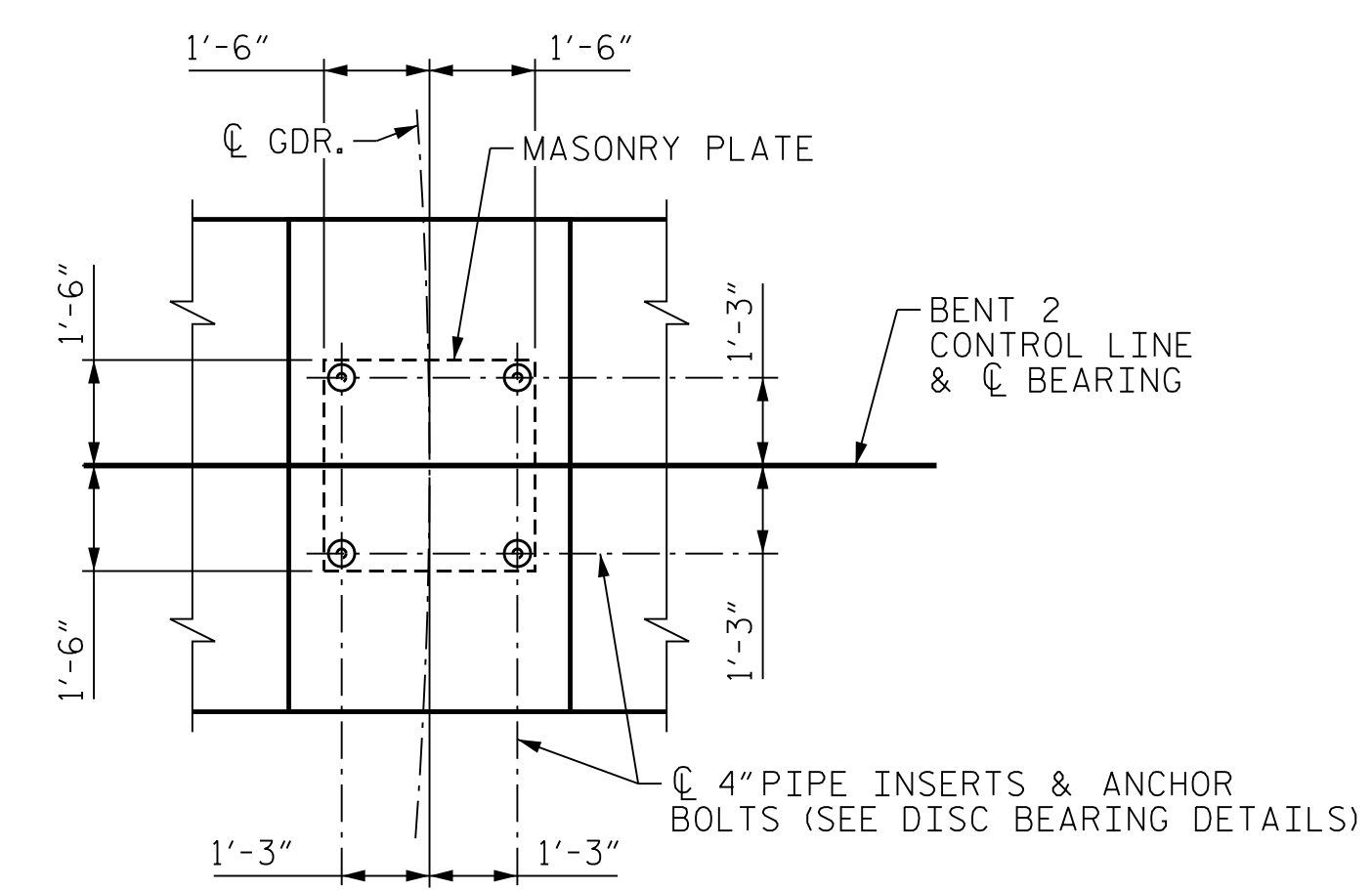

DETAIL "A"  
(TYP. @ EA. BEARING)

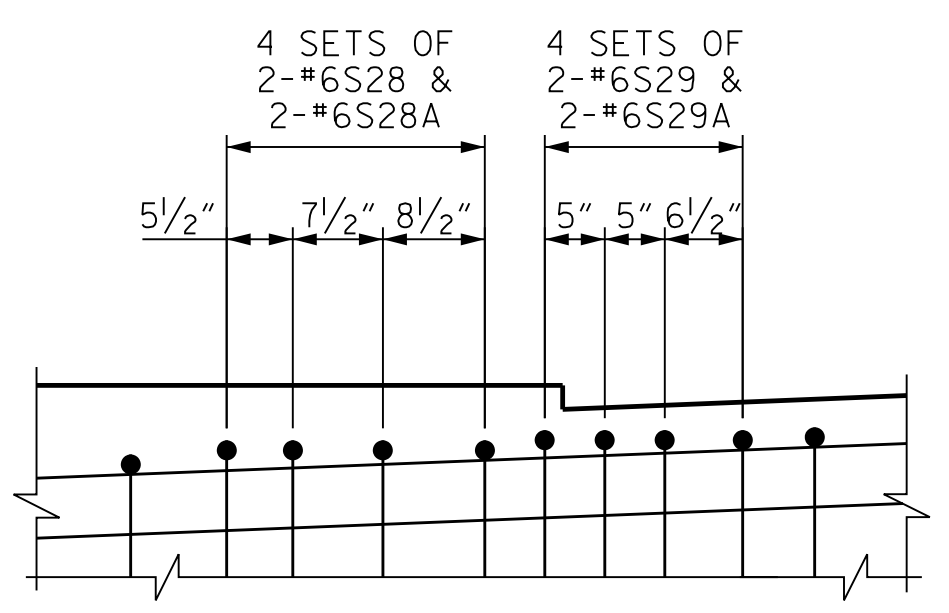

DETAIL "C"

DETAIL SHOWN AT LEFT SIDE OF CAP (SPACING OF STIRRUPS MIRRORED AT RIGHT SIDE OF CAP WITH BARS #6S30/#6S30A AND #6S31/#6S31A AS SHOWN ON THE ELEVATION)

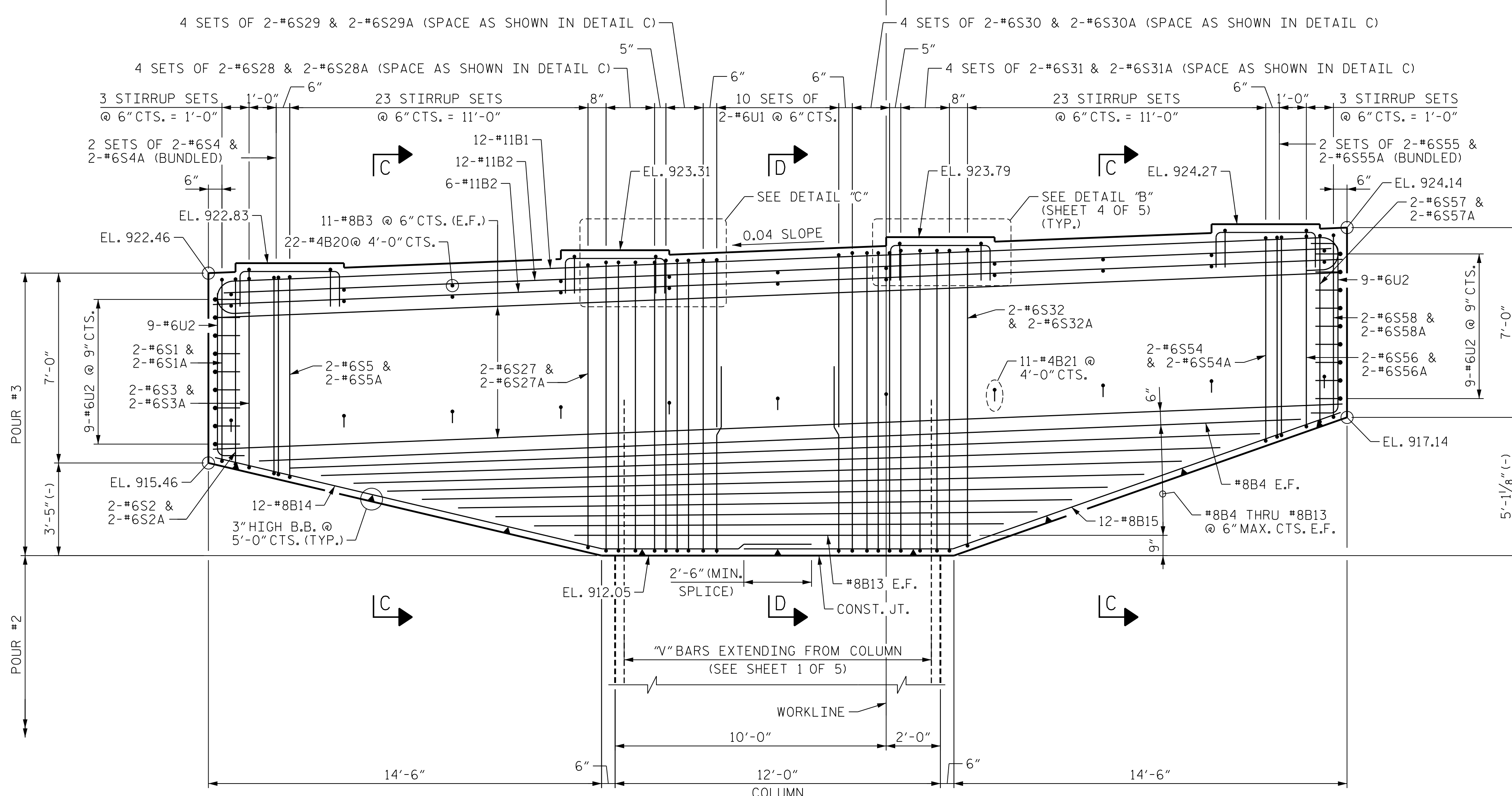

ELEVATION OF CAP

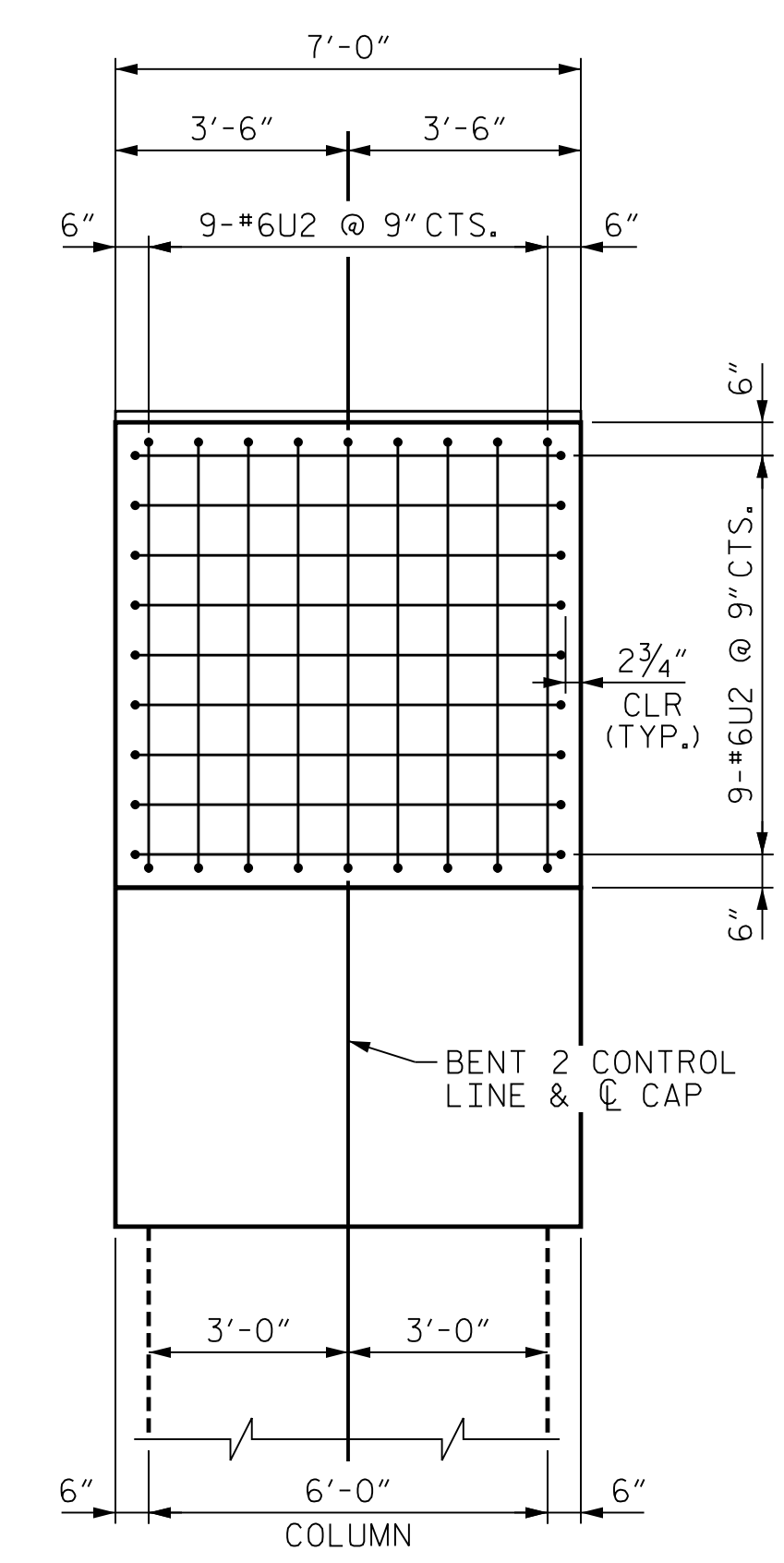

END VIEW

PROJECT NO. U-2579AB  
 FORSYTH COUNTY  
 STATION: 60+66.06 -Y15FLYAC-  
 SHEET 3 OF 5

STATE OF NORTH CAROLINA  
 DEPARTMENT OF TRANSPORTATION  
 RALEIGH

**SUBSTRUCTURE  
 BENT 2  
 BENT CAP PLAN  
 & ELEVATION**



10/15/2021

REVISIONS						SHEET NO. 504-097
NO.	BY:	DATE:	NO.	BY:	DATE:	
1	--	--	3	--	--	TOTAL SHEETS 144
2	--	--	4	--	--	

**HDR** HDR Engineering, Inc. of the Carolinas  
 555 Fayetteville St., Suite 900 Raleigh, N.C. 27601  
 N.C.B.E.L.S. License Number: F-0116

DOCUMENT NOT CONSIDERED FINAL  
 UNLESS ALL SIGNATURES COMPLETED

PLOT DRIVER: NCDOT.pdf\_color\_eng-50dpi  
 USER: PPETERSO DATE: 10/14/2021 TIME: 4:06:14 PM  
 FILE: ...SUBSTR

DES BY: K. OLIVER	DATE: 10/19	DWG BY: B. PETERSON	DATE: 10/19
DES CHK: M. WERNER	DATE: 10/19	CHK BY: K. OLIVER	DATE: 11/19