

8/23/99

0 10 20	PROJ. REFERENCE NO.	SHEET NO.
	U-2579AB	X-413

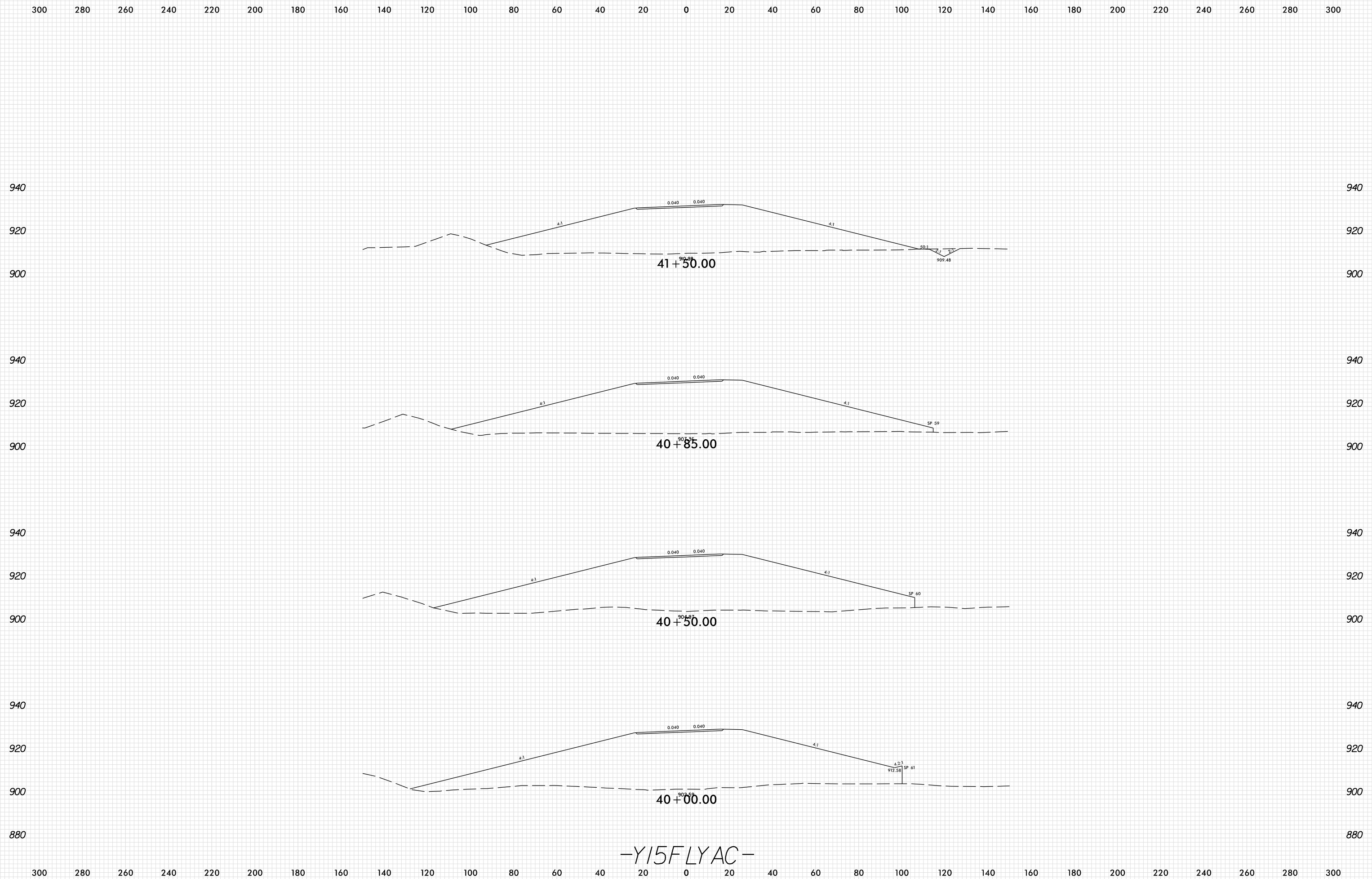

-Y15FLYAC-

PLOT DRIVER: NCD01\_pdf\_color\_eng\_100.plt  
 USER: SPEREIRA  
 DATE: 6/10/2021  
 TIME: 2:25:54 PM  
 FILE: \

8/23/99

0 10 20	PROJ. REFERENCE NO.	SHEET NO.
	U-2579AB	X-414

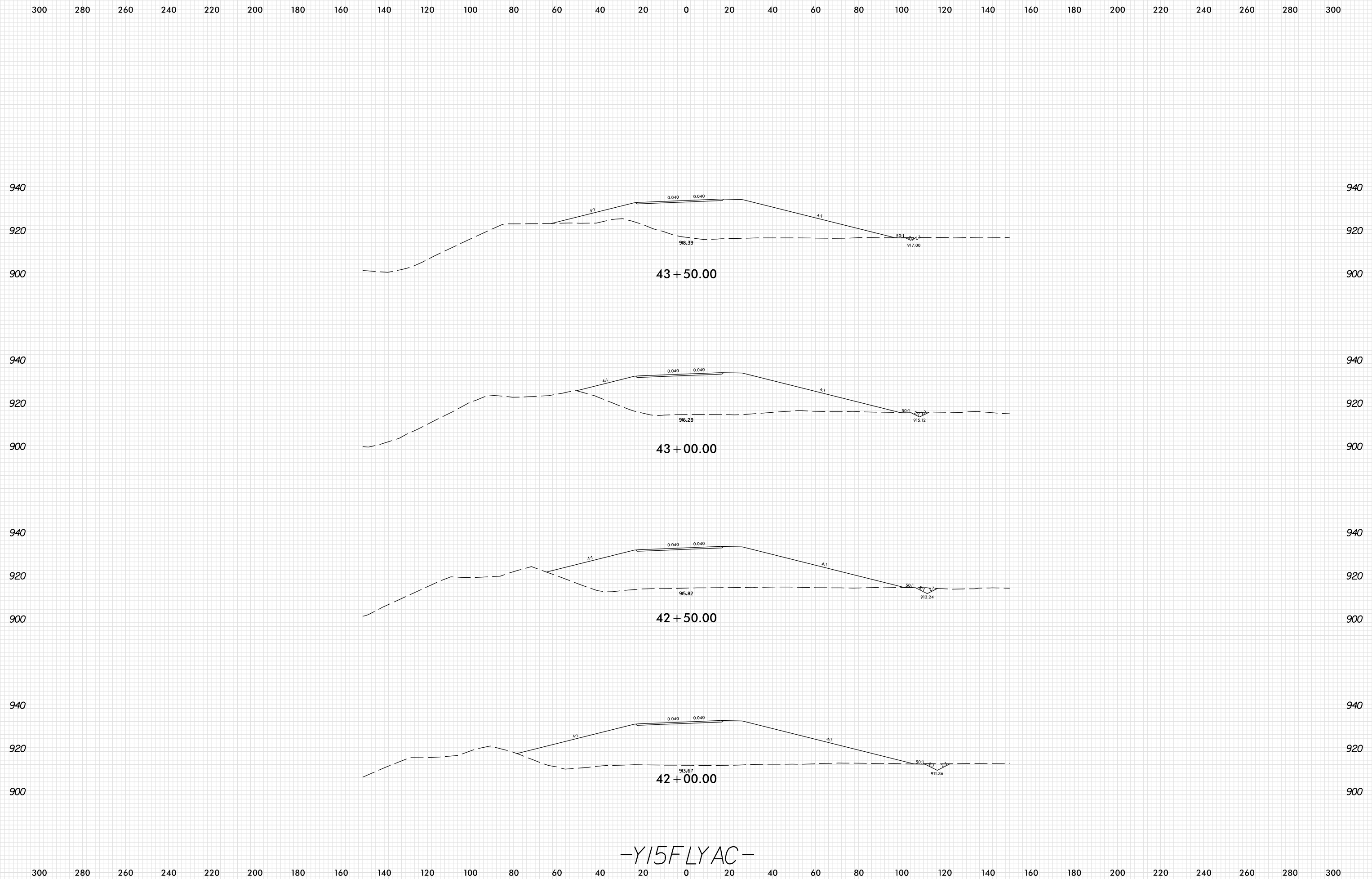

-Y15FLYAC-

PLOT DRIVER: NCD01\_pdf\_color\_eng\_100.plt  
 USER: SPEREIRA  
 DATE: 6/10/2021  
 TIME: 2:25:55 PM  
 FILE: \

8/23/99

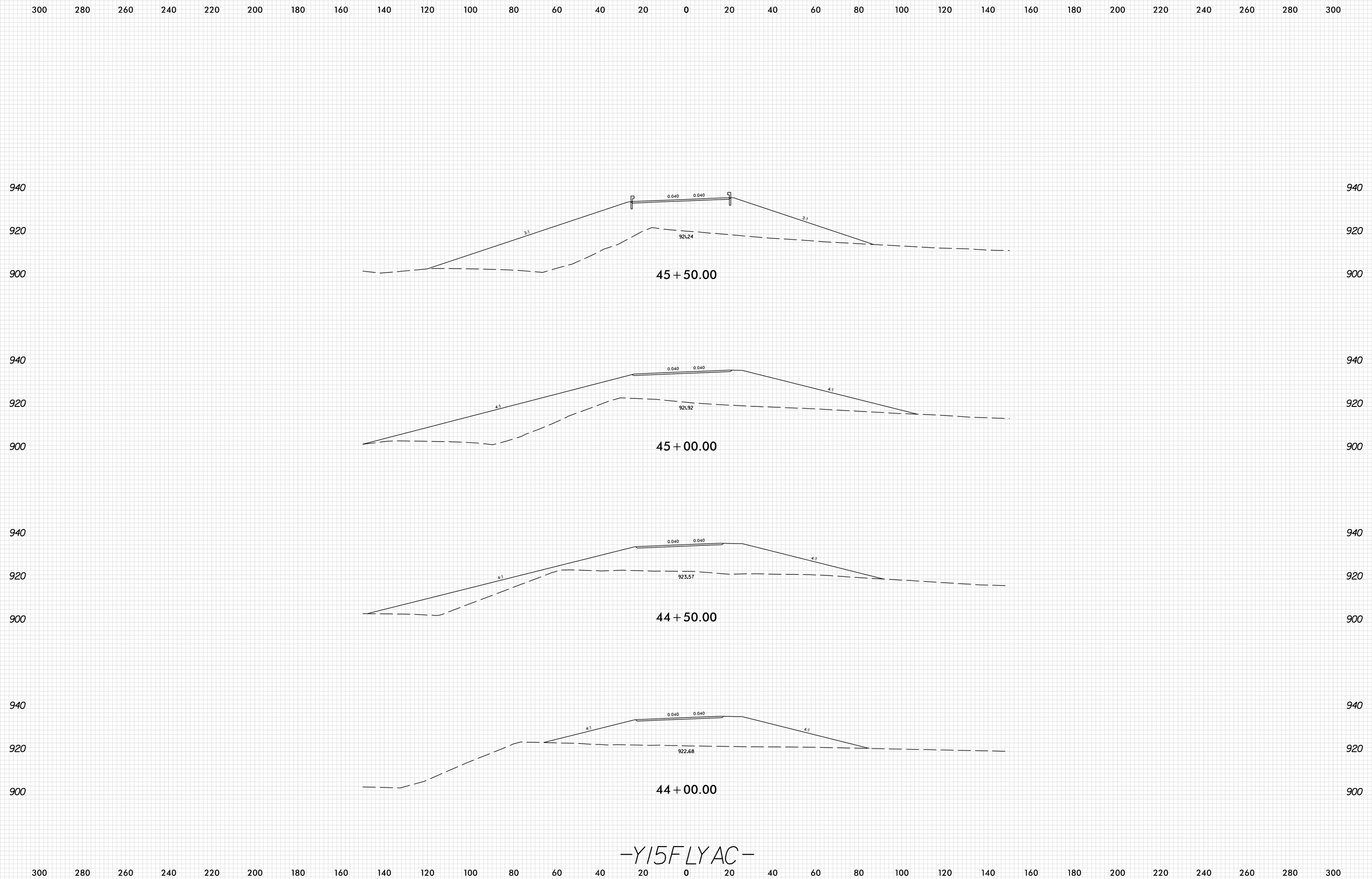

-Y15FLYAC-

PLOT DRIVER: NCD01\_pdf\_color\_eng\_100.plt  
 USER: SPEREIRA  
 DATE: 6/10/2021  
 TIME: 2:25:56 PM  
 FILE: \

8/23/99

0 10 20	PROJ. REFERENCE NO.	SHEET NO.
	U-2579AB	X-416

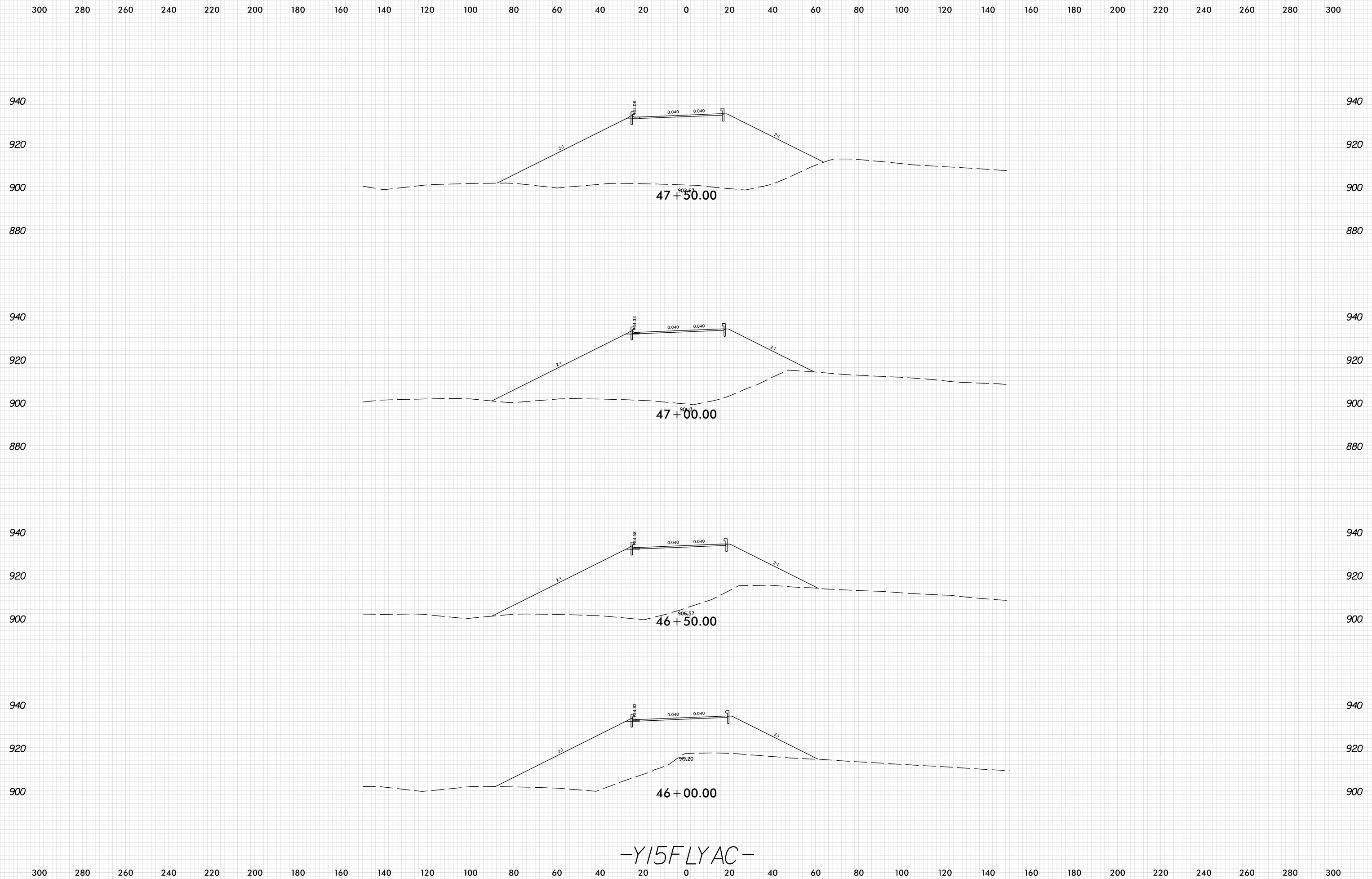

PLOT DRIVER: NCD01\_pdf\_color\_eng\_100.plt  
 USER: SPEREIRA  
 DATE: 6/10/2021  
 TIME: 2:25:57 PM  
 FILE: \

8/23/99

0 10 20	PROJ. REFERENCE NO.	SHEET NO.
	U-2579AB	X-417

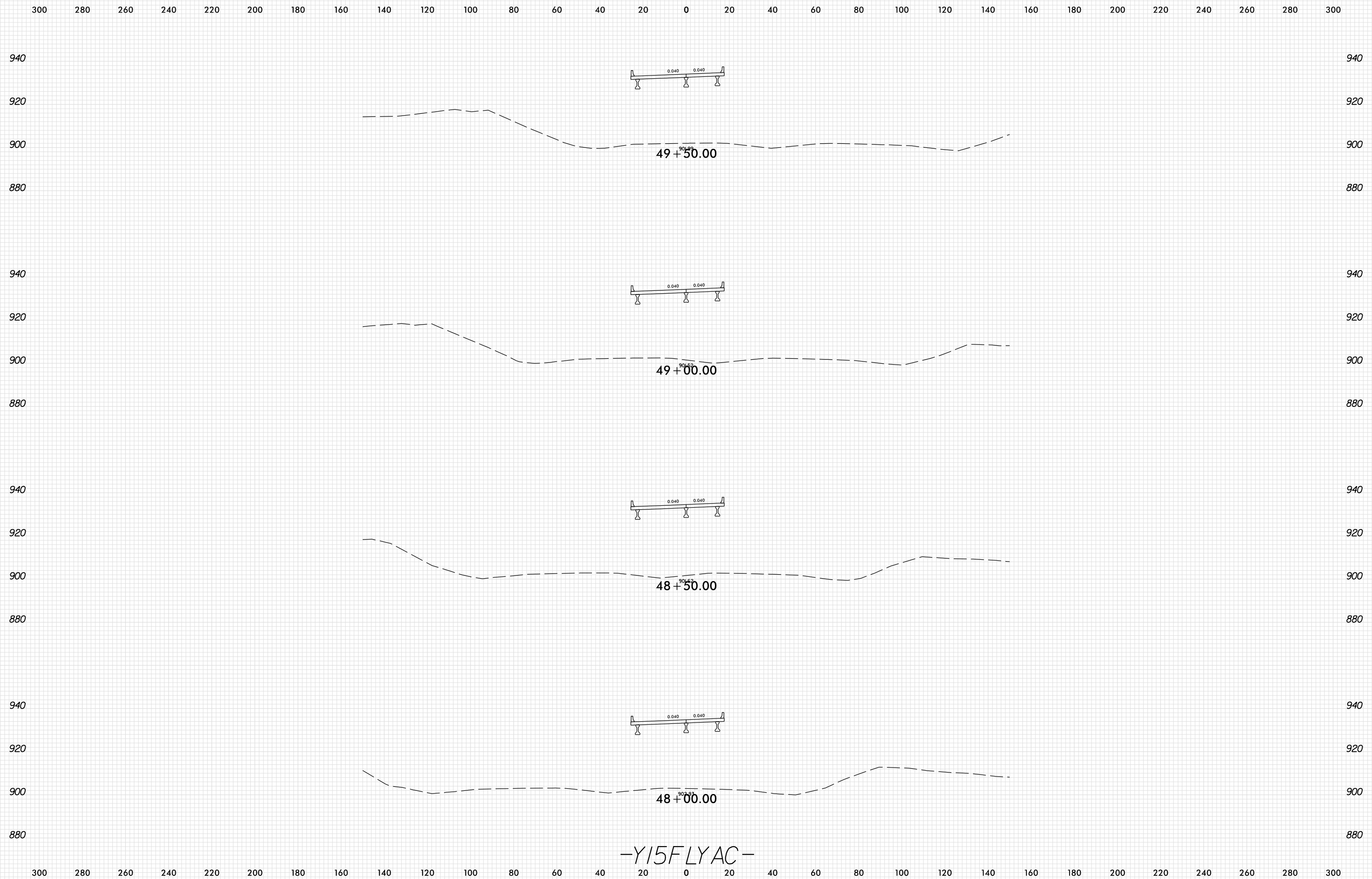

-Y15FLYAC-

PLOT DRIVER: NCD01\_pdf\_color\_eng\_100.plt  
 USER: SPEREIRA  
 DATE: 6/10/2021  
 TIME: 2:25:58 PM  
 FILE: \

8/23/99

0 10 20	PROJ. REFERENCE NO.	SHEET NO.
	U-2579AB	X-418

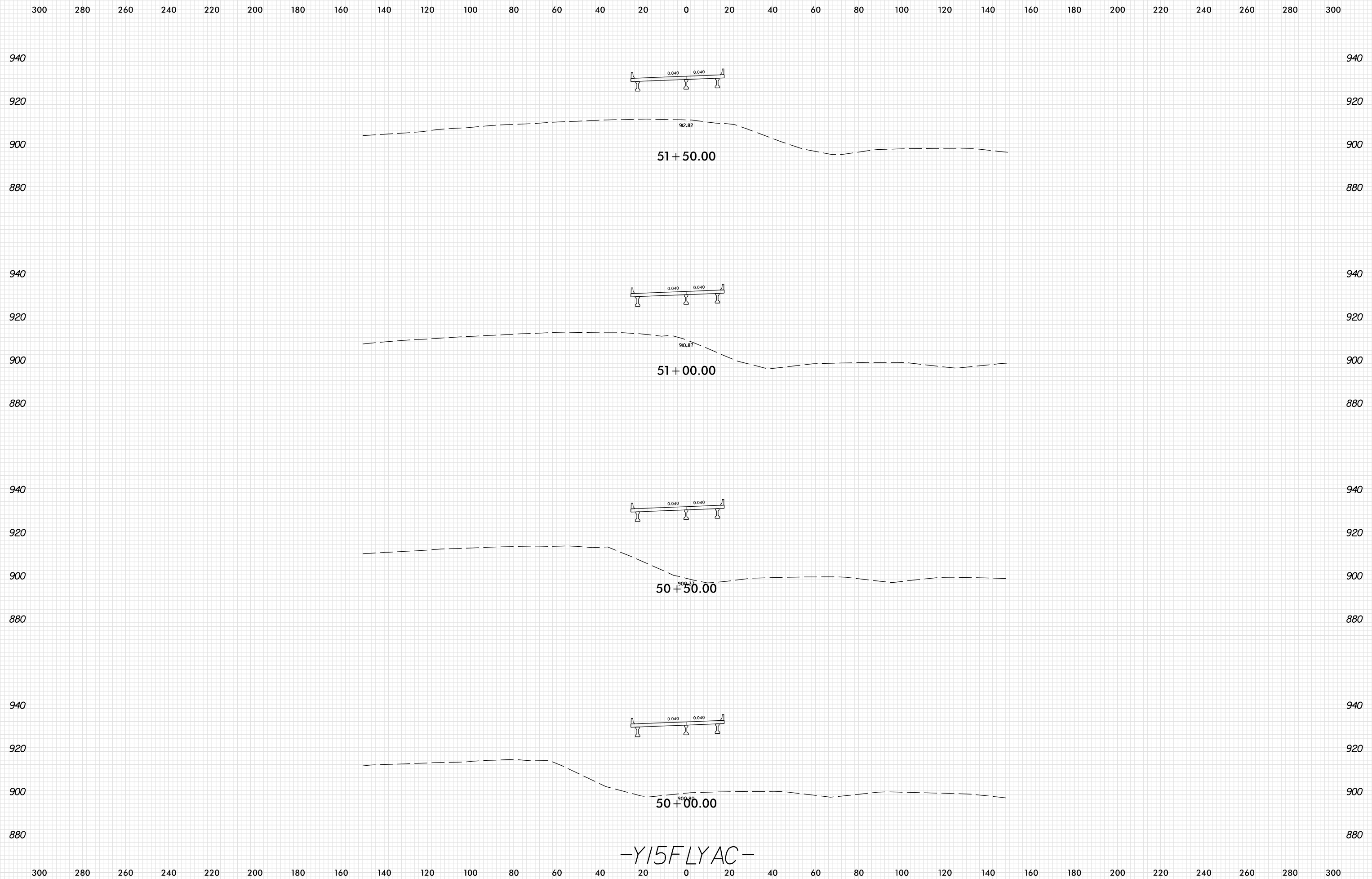

-Y15FLYAC-

PLOT DRIVER: NCD01\_pdf\_color\_eng\_100.plt  
 USER: SPEREIRA  
 DATE: 6/10/2021  
 TIME: 2:25:58 PM  
 FILE: \

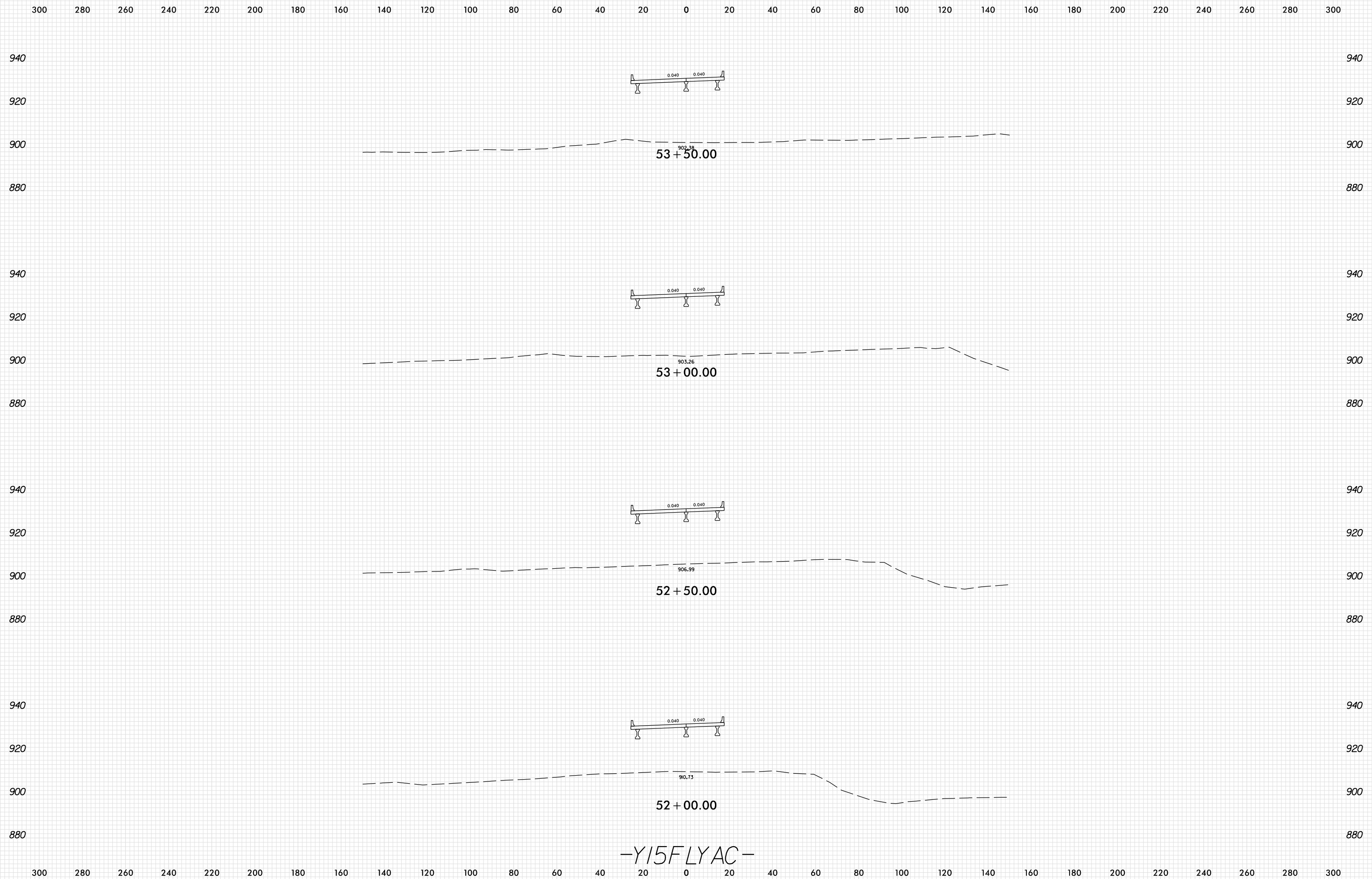

8/23/99

0 10 20	PROJ. REFERENCE NO.	SHEET NO.
	U-2579AB	X-420

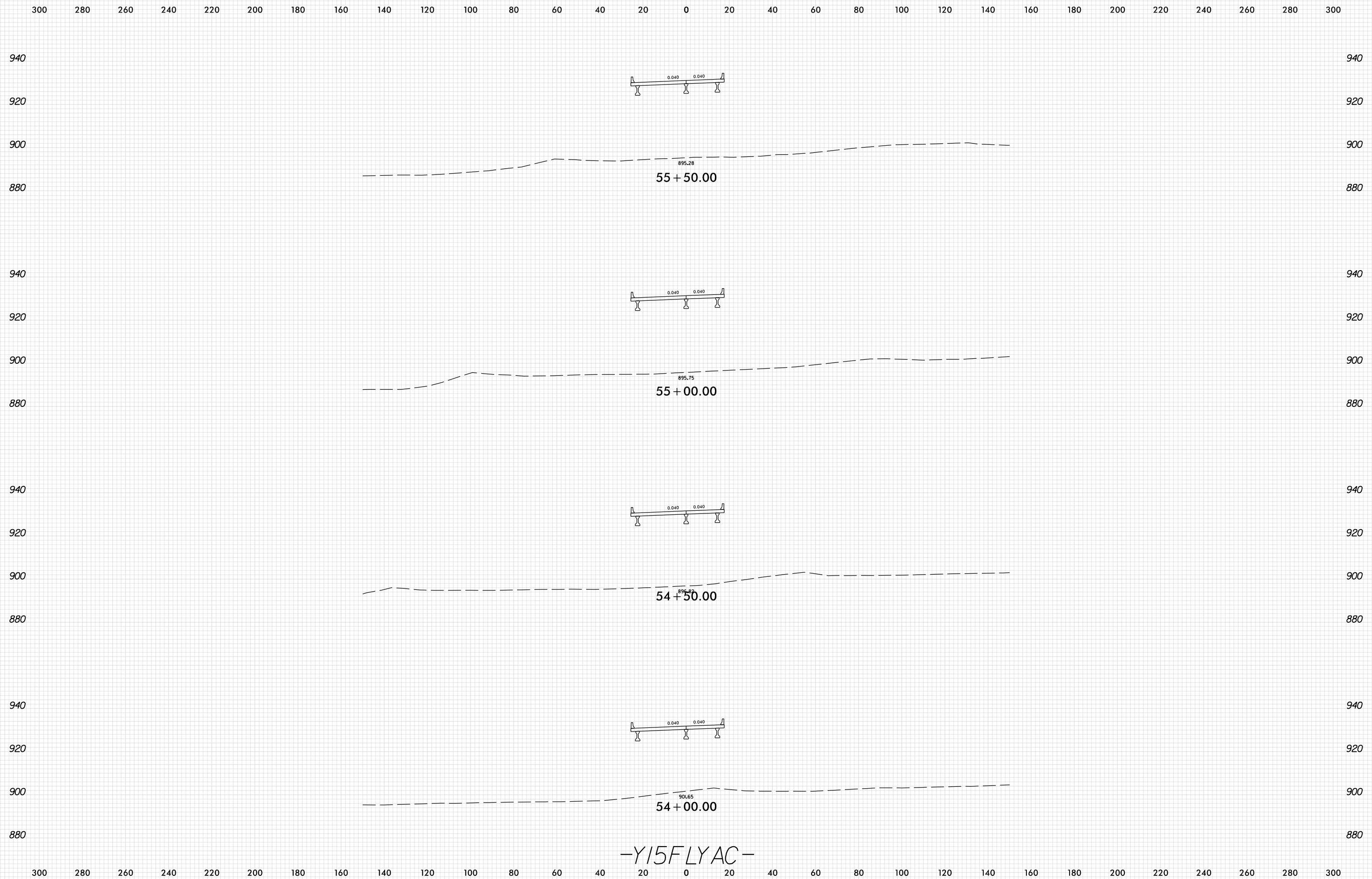

-Y15FLYAC-

PLOT DRIVER: NCDOT\_pdf\_color\_eng\_100.plt  
 USER: SPEREIRA  
 DATE: 6/10/2021  
 TIME: 2:26:00 PM  
 FILE: \



8/23/99

0 10 20	PROJ. REFERENCE NO.	SHEET NO.
	U-2579AB	X-421

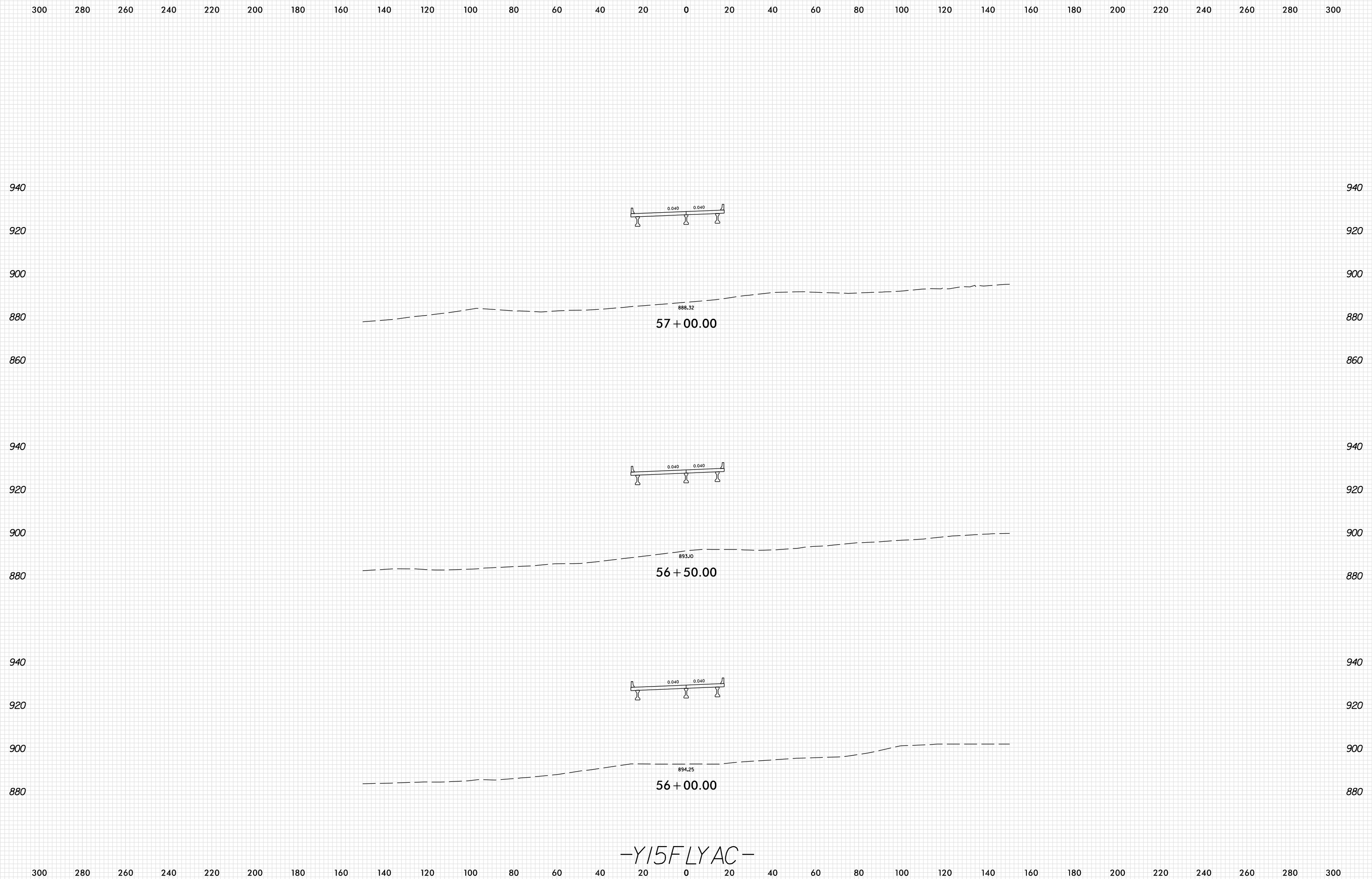

PLOT DRIVER: NCD01\_pdf\_color\_eng\_100.plt  
 USER: SPEREIRA  
 FILE: \PENTABLE; xpl\_en\_v8.tbl  
 DATE: 6/10/2021  
 TIME: 2:26:01 PM

8/23/99

0 10 20	PROJ. REFERENCE NO.	SHEET NO.
	U-2579AB	X-422

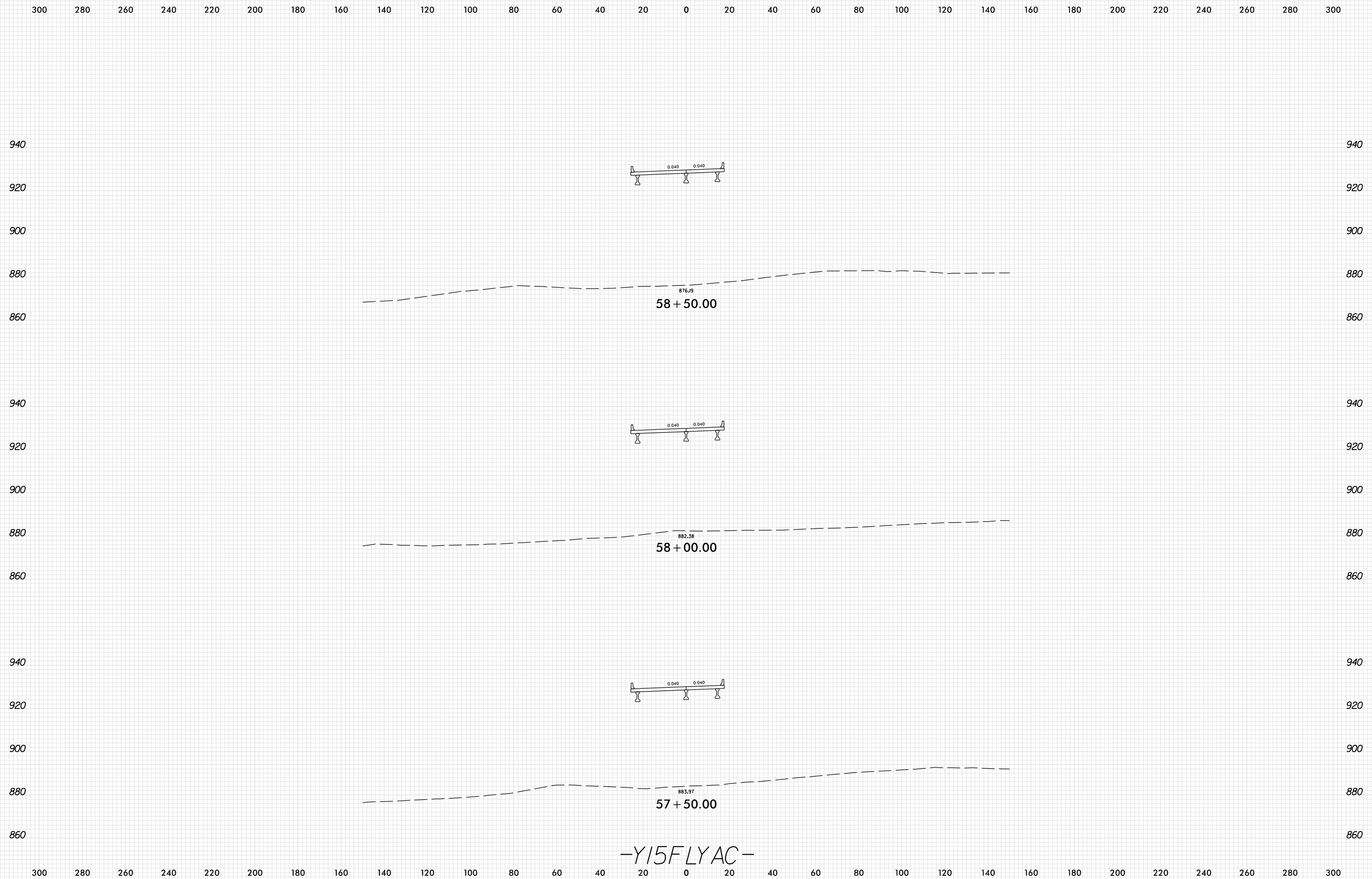

PLOT DRIVER: NCD01\_pdf\_color\_eng\_100.plt  
 USER: SPEREIRA  
 FILE: \PENTABLE; xpl\_en\_v8.tbi  
 DATE: 6/10/2021  
 TIME: 2:26:01 PM

8/23/99

0 10 20	PROJ. REFERENCE NO.	SHEET NO.
	U-2579AB	X-423

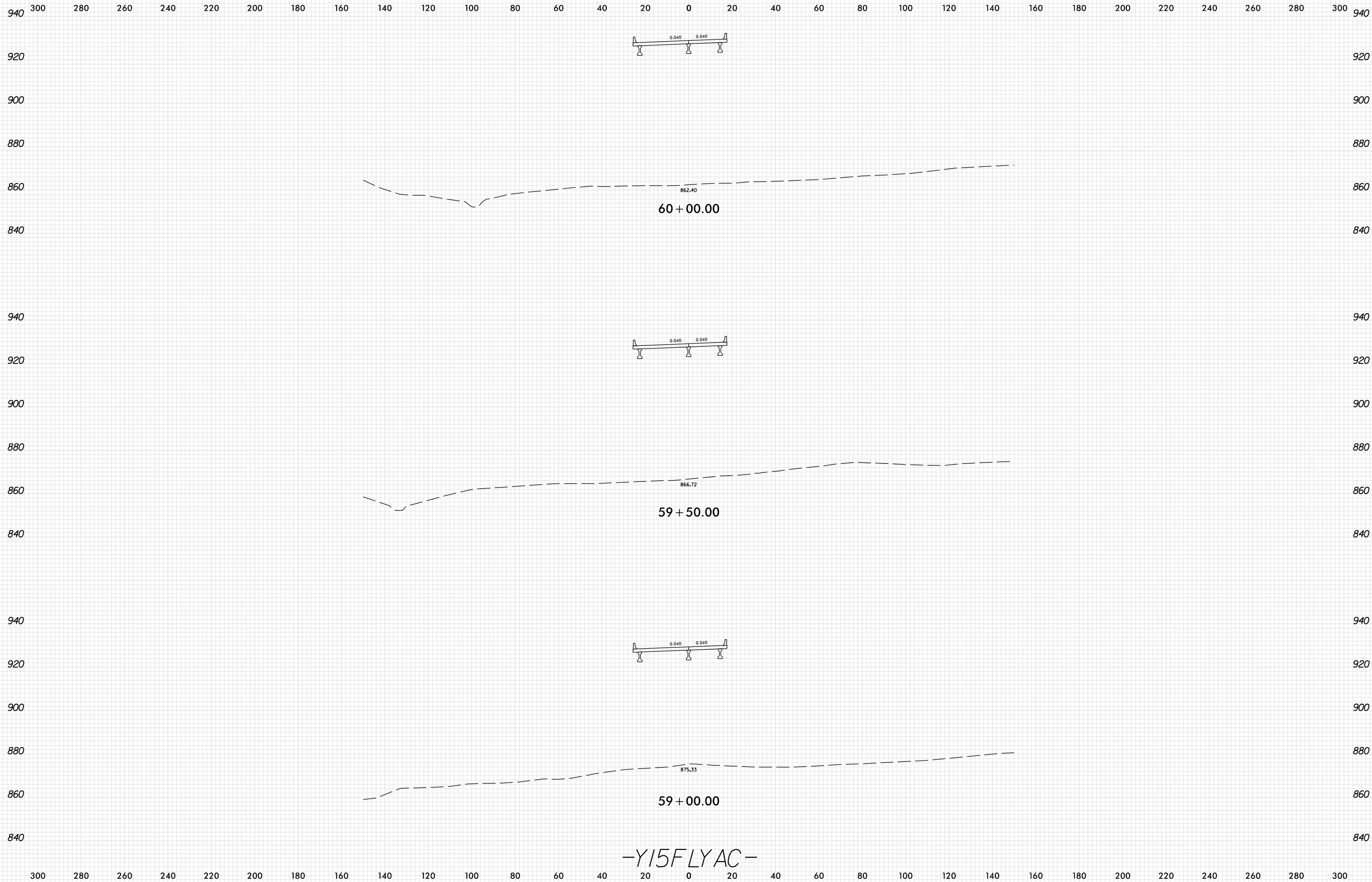

-Y15FLYAC-

PLOT DRIVER: NCDOT\_pdf\_color\_eng\_100.plt  
 USER: SPEREIRA  
 DATE: 6/10/2021  
 TIME: 2:26:02 PM  
 FILE: \

8/23/99

0 10 20	PROJ. REFERENCE NO.	SHEET NO.
	U-2579AB	X-424

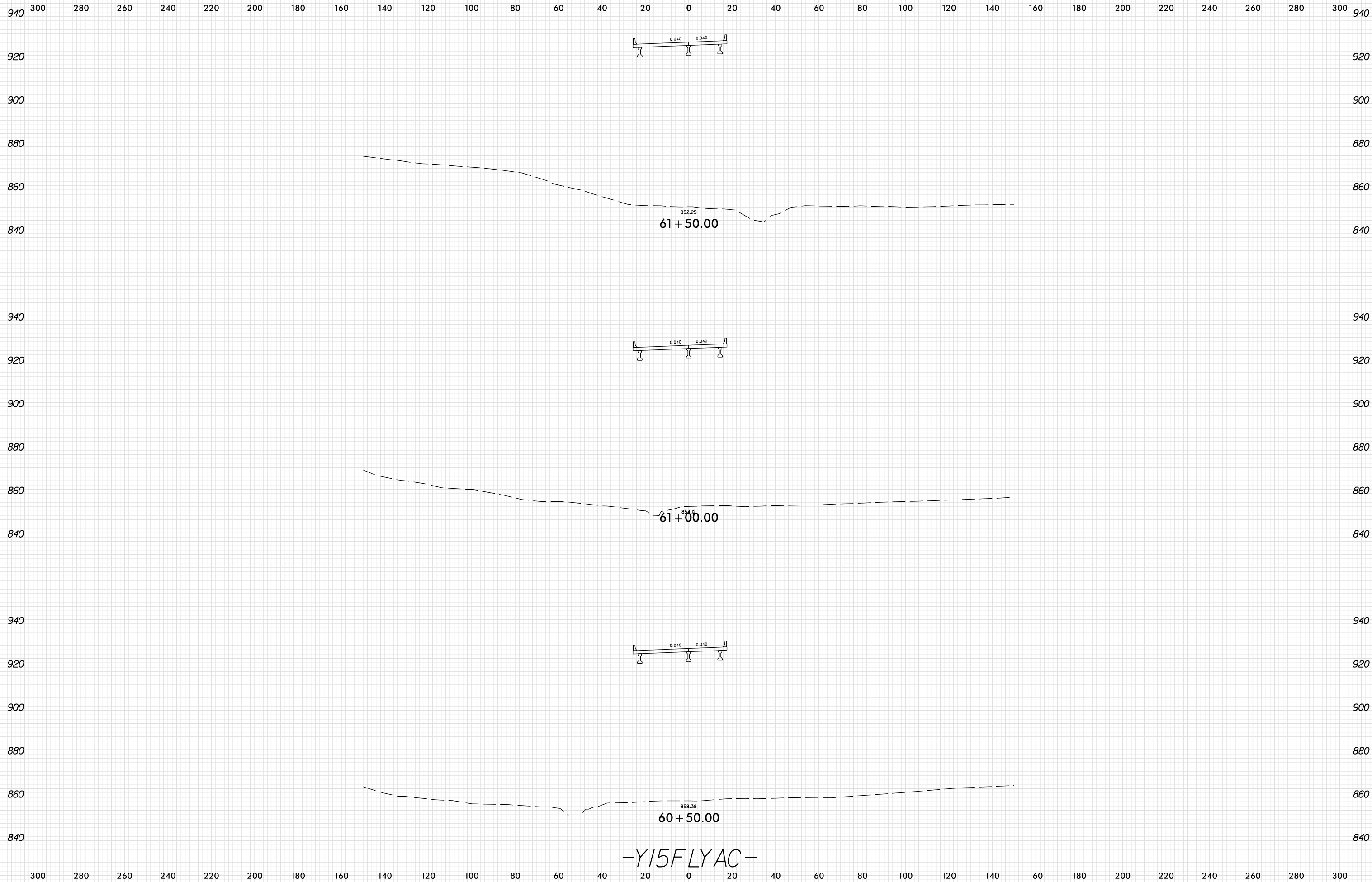

-Y15FLYAC-

PLOT DRIVER: NCD01\_pdf\_color\_eng\_100.plt  
 USER: SPEREIRA  
 DATE: 6/10/2021  
 TIME: 2:26:03 PM  
 FILE: \

8/23/99

0 10 20	PROJ. REFERENCE NO.	SHEET NO.
	U-2579AB	X-425

300 280 260 240 220 200 180 160 140 120 100 80 60 40 20 0 20 40 60 80 100 120 140 160 180 200 220 240 260 280 300

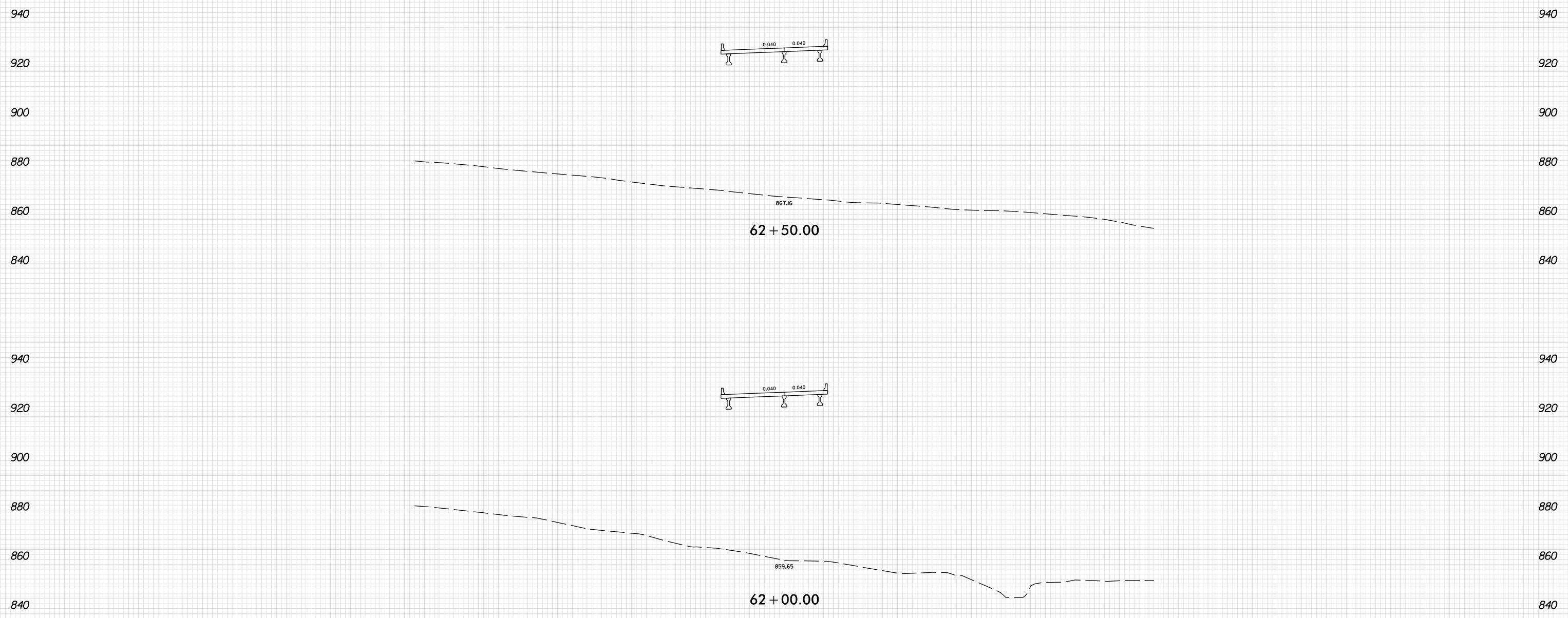

PLOT DRIVER: NCDOT\_pdf\_color\_eng\_100.plt  
 USER: SPEREIRA  
 DATE: 6/10/2021  
 TIME: 2:26:04 PM

300 280 260 240 220 200 180 160 140 120 100 80 60 40 20 0 20 40 60 80 100 120 140 160 180 200 220 240 260 280 300

8/23/99

0 10 20	PROJ. REFERENCE NO.	SHEET NO.
	U-2579AB	X-426

940 300 280 260 240 220 200 180 160 140 120 100 80 60 40 20 0 20 40 60 80 100 120 140 160 180 200 220 240 260 280 300 940

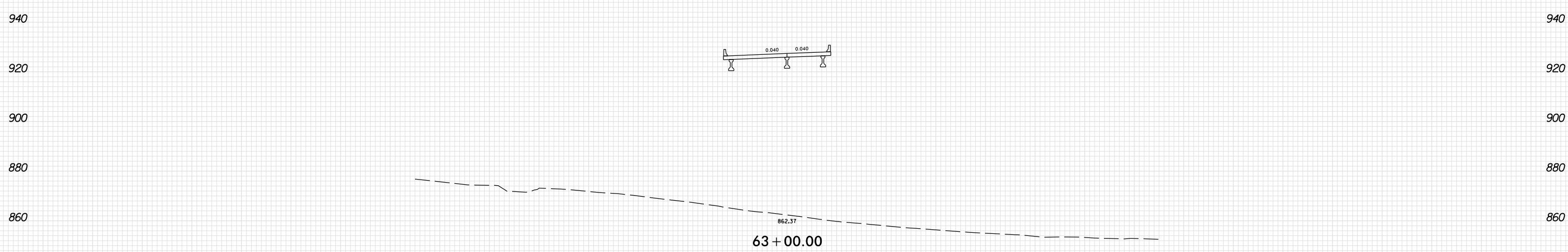
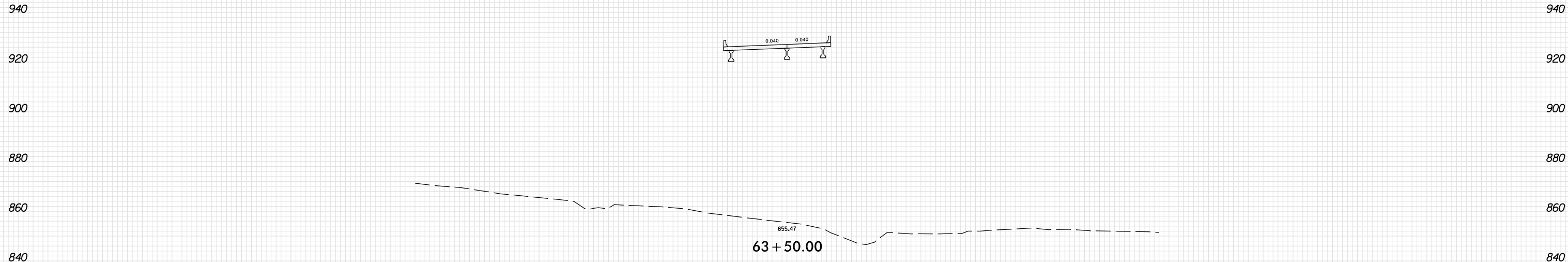
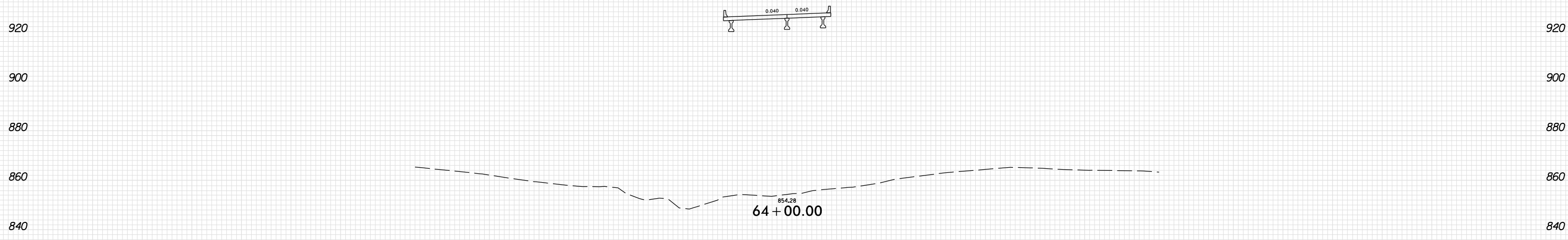

300 280 260 240 220 200 180 160 140 120 100 80 60 40 20 0 20 40 60 80 100 120 140 160 180 200 220 240 260 280 300

-Y15FLYAC-

PLOT DRIVER: NCD01\_pdf\_color\_eng\_100.plt  
 USER: SPEREIRA  
 DATE: 6/10/2021  
 TIME: 2:26:04 PM  
 FILE: \

8/23/99

0 10 20	PROJ. REFERENCE NO.	SHEET NO.
	U-2579AB	X-427

940 300 280 260 240 220 200 180 160 140 120 100 80 60 40 20 0 20 40 60 80 100 120 140 160 180 200 220 240 260 280 300 940

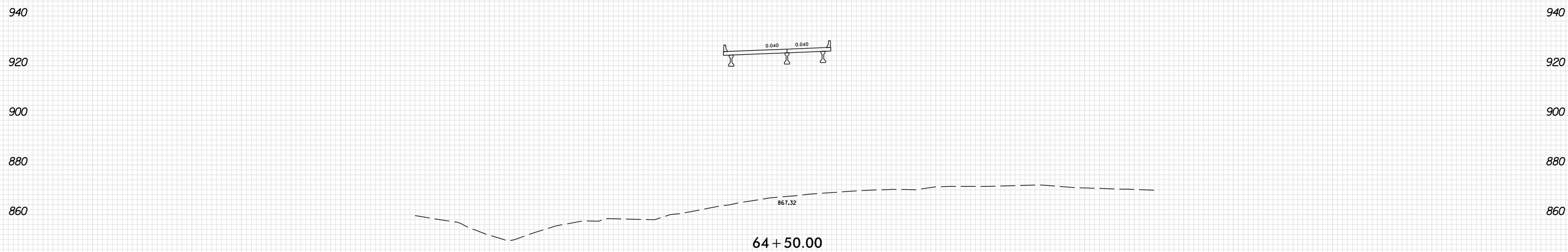
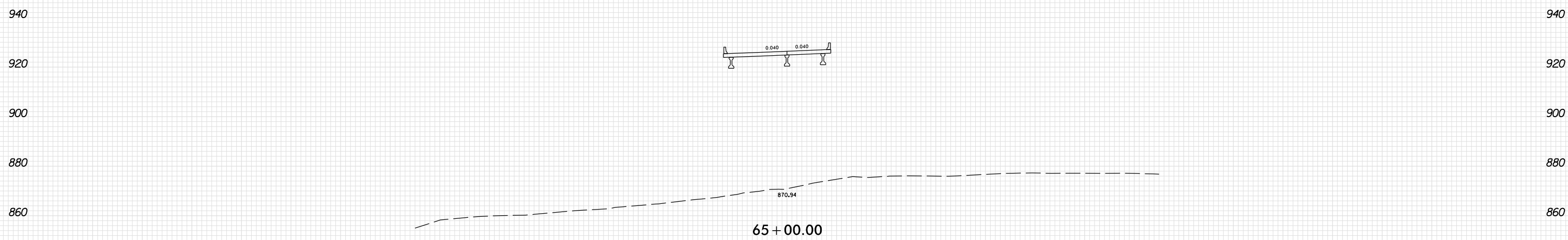
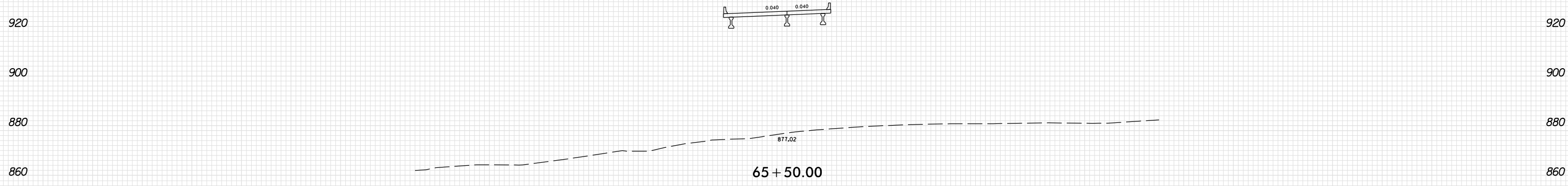

300 280 260 240 220 200 180 160 140 120 100 80 60 40 20 0 20 40 60 80 100 120 140 160 180 200 220 240 260 280 300

-Y15FLYAC-

PLOT DRIVER: NCDOT\_pdf\_color\_eng\_100.plt  
 USER: SPEREIRA  
 DATE: 6/10/2021  
 TIME: 2:26:05 PM  
 FILE: \

8/23/99

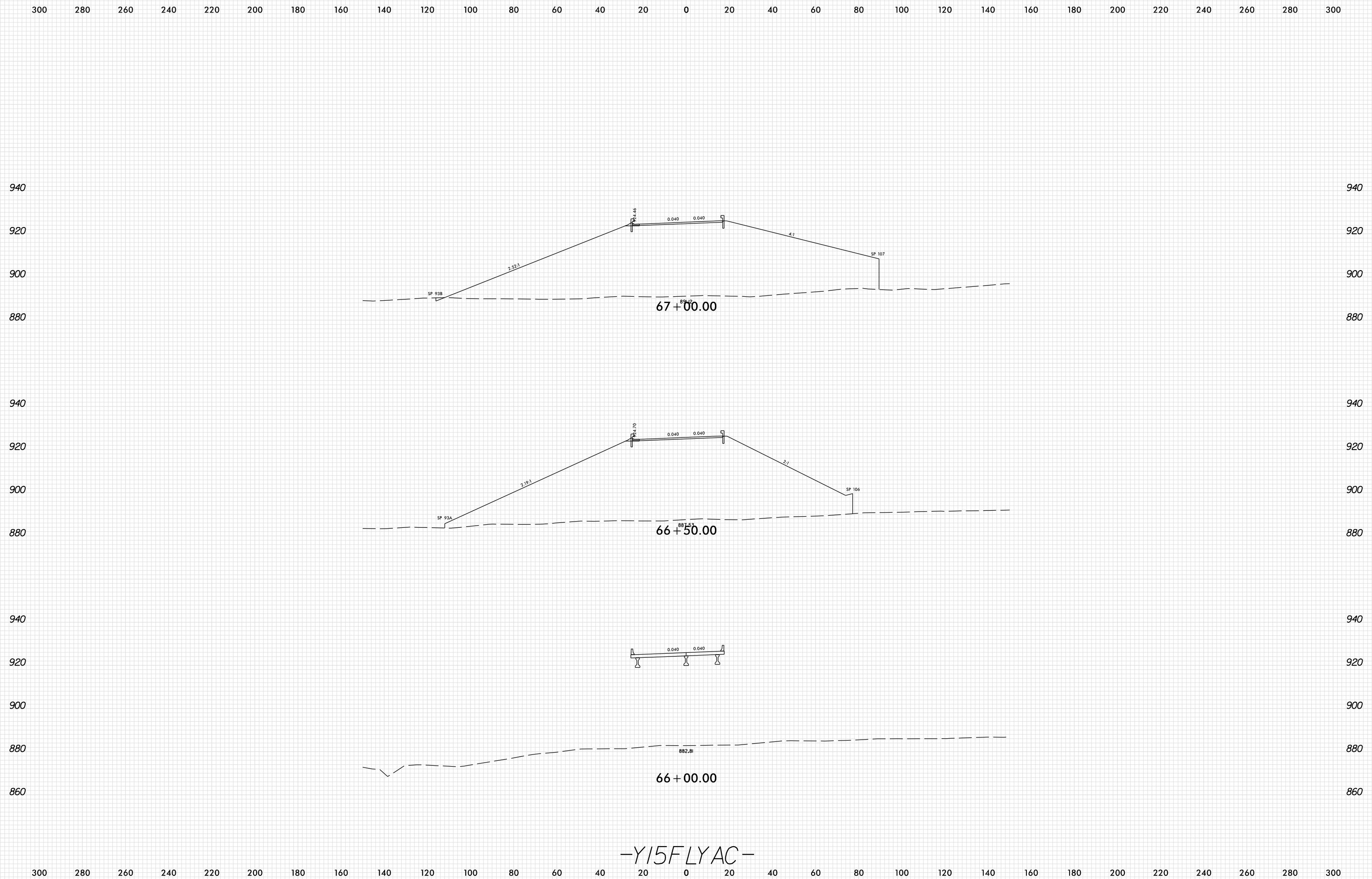

-Y15FLYAC-

PLOT DRIVER: NCD01\_pdf\_color\_eng\_100.plt  
 USER: SPEREIRA  
 FILE: \

DATE: 6/10/2021  
 TIME: 2:26:06 PM

PENTABLE: xpl\_en\_v8.tbl



8/23/99

0 10 20	PROJ. REFERENCE NO.	SHEET NO.
	U-2579AB	X-429

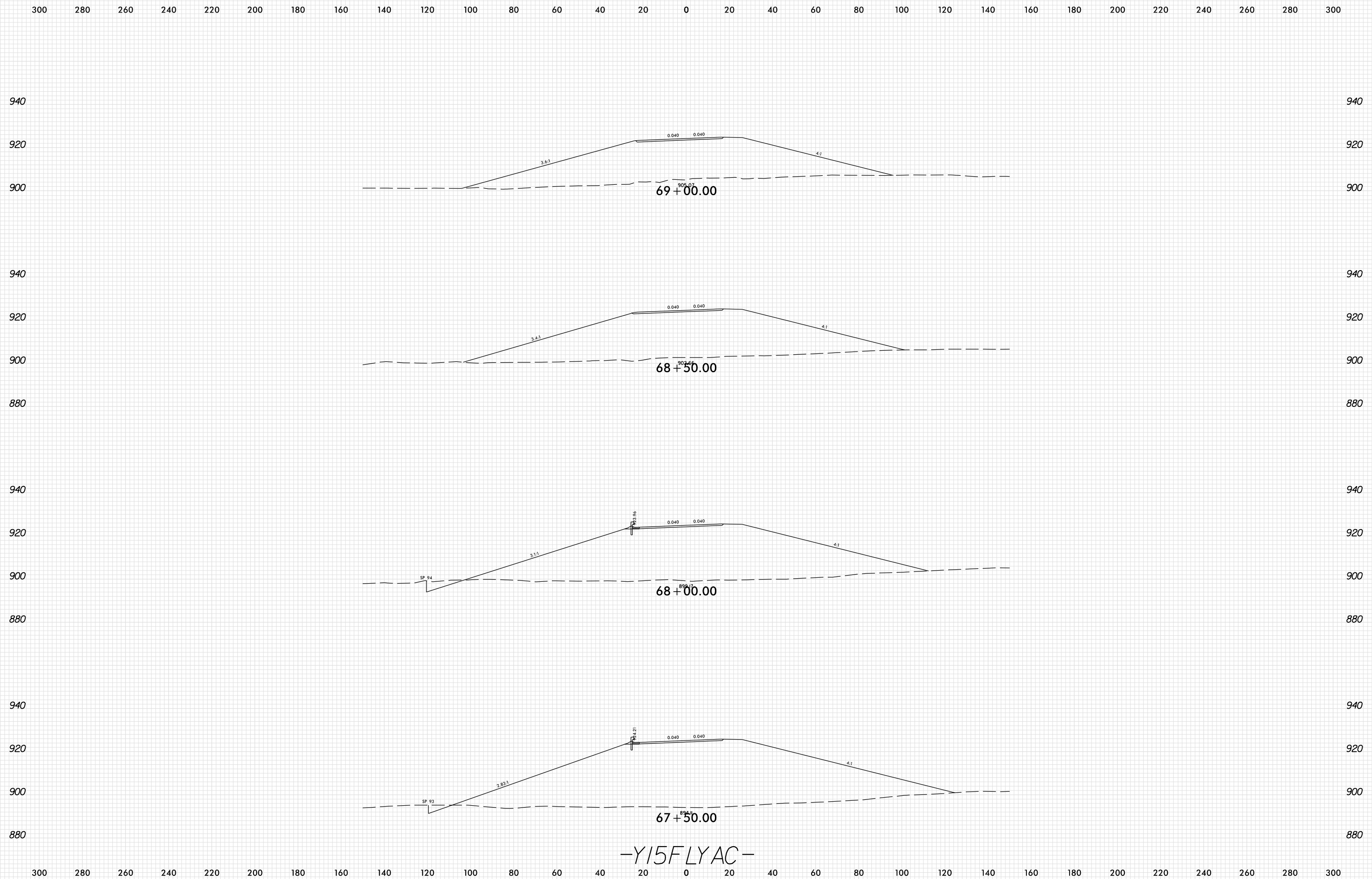

PLOT DRIVER: NCD01\_pdf\_color\_eng\_100.plt  
 USER: SPEREIRA  
 DATE: 6/10/2021  
 TIME: 2:26:07 PM  
 FILE: \

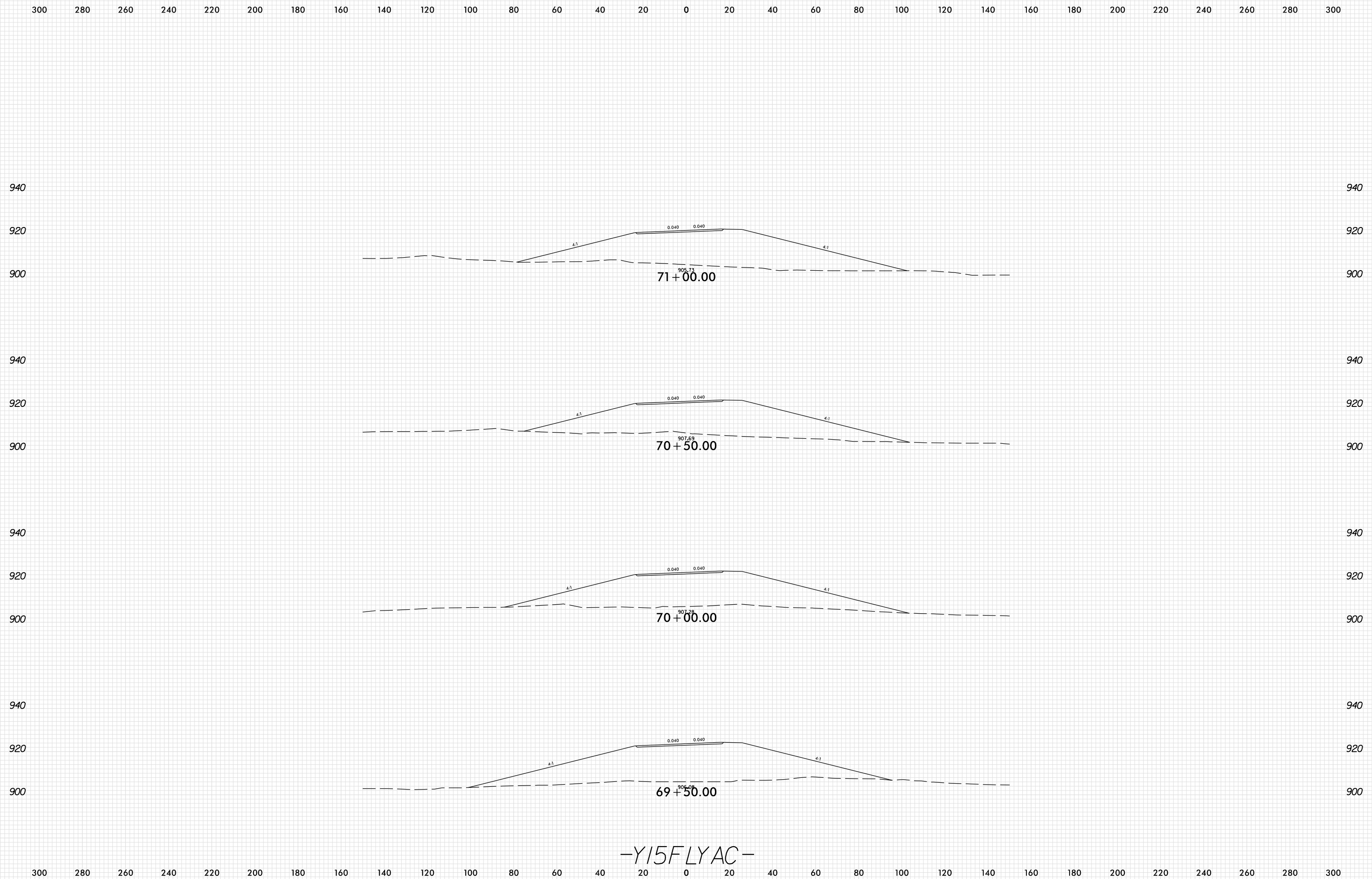

-Y15FLYAC-

8/23/99

0 10 20	PROJ. REFERENCE NO.	SHEET NO.
	U-2579AB	X-431

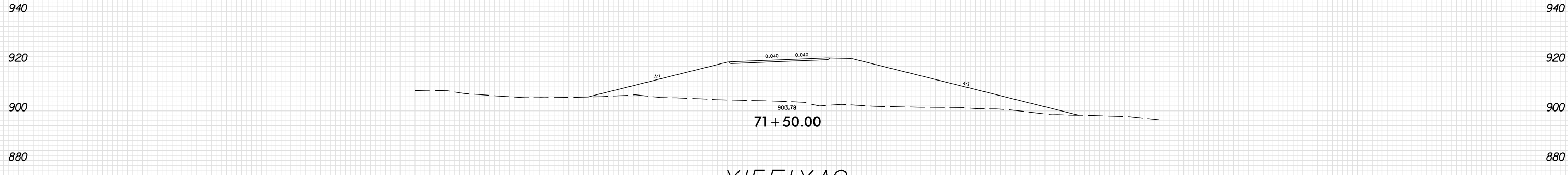
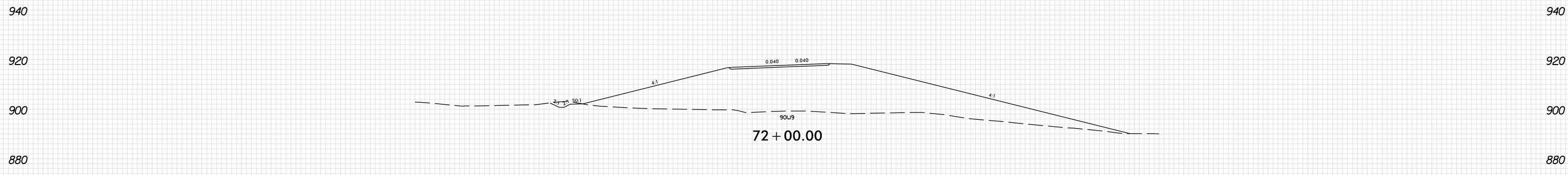
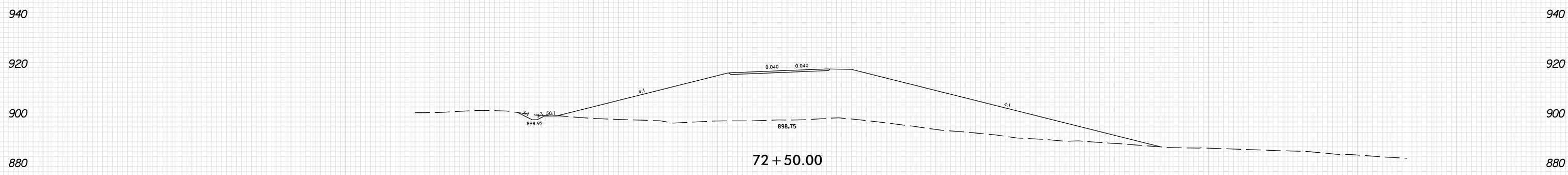
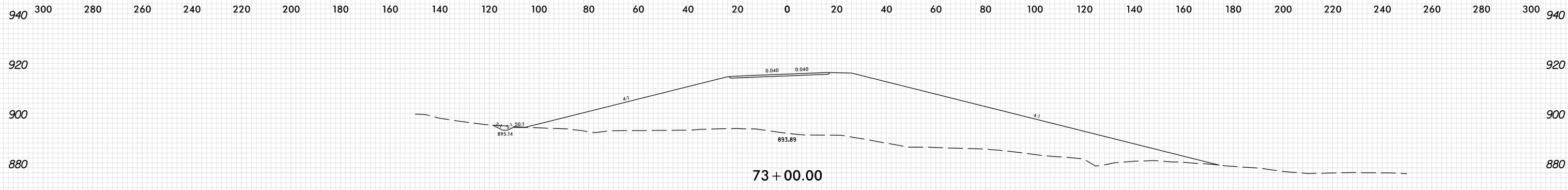

-Y15FLYAC-

PLOT DRIVER: NCD01\_pdf\_color\_eng\_100.plt  
 USER: SPEREIRA  
 DATE: 6/10/2021  
 TIME: 2:26:08 PM  
 FILE: \

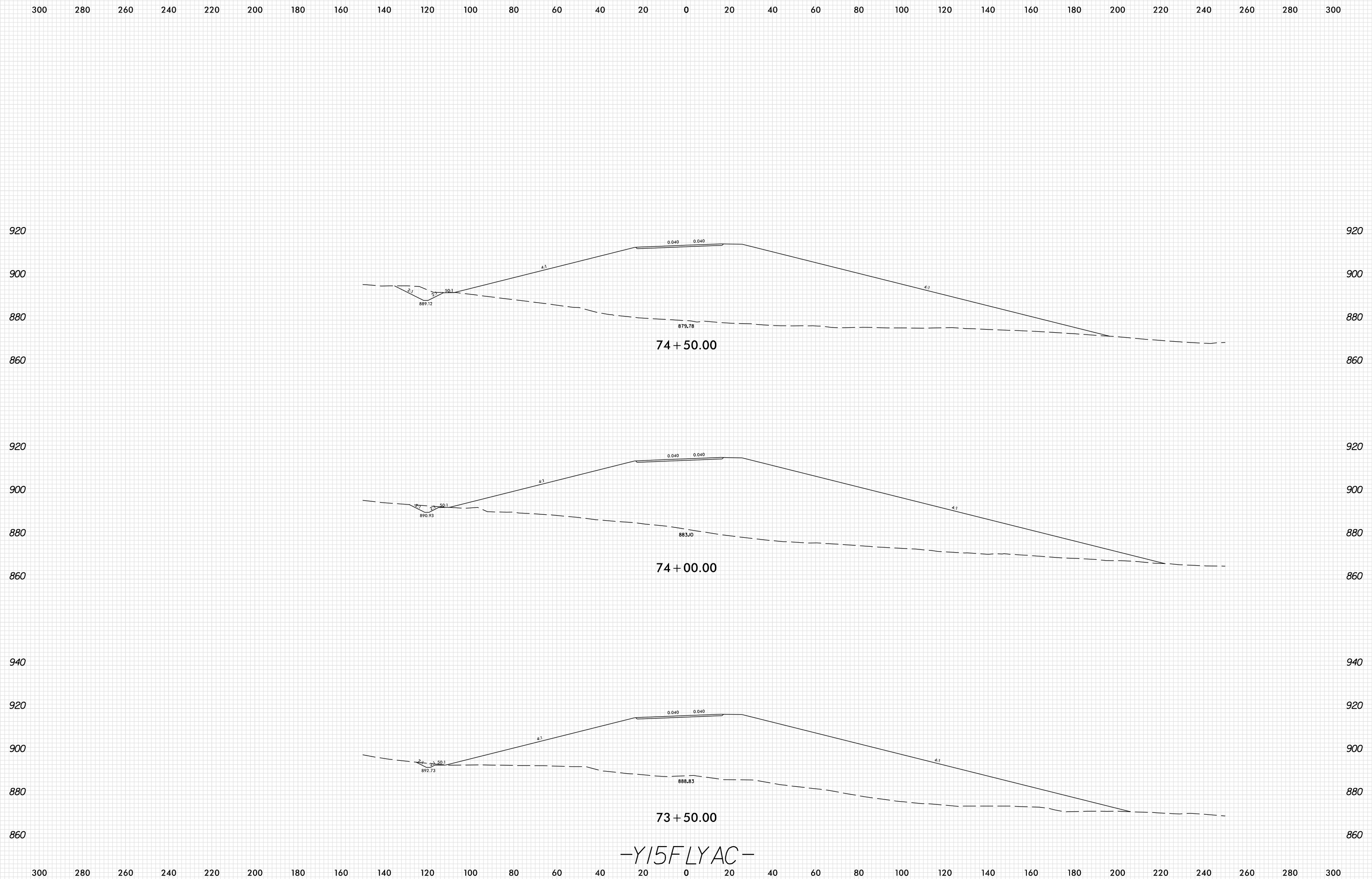

-Y15FLYAC-

8/23/99



PROJ. REFERENCE NO.	SHEET NO.
U-2579AB	X-433

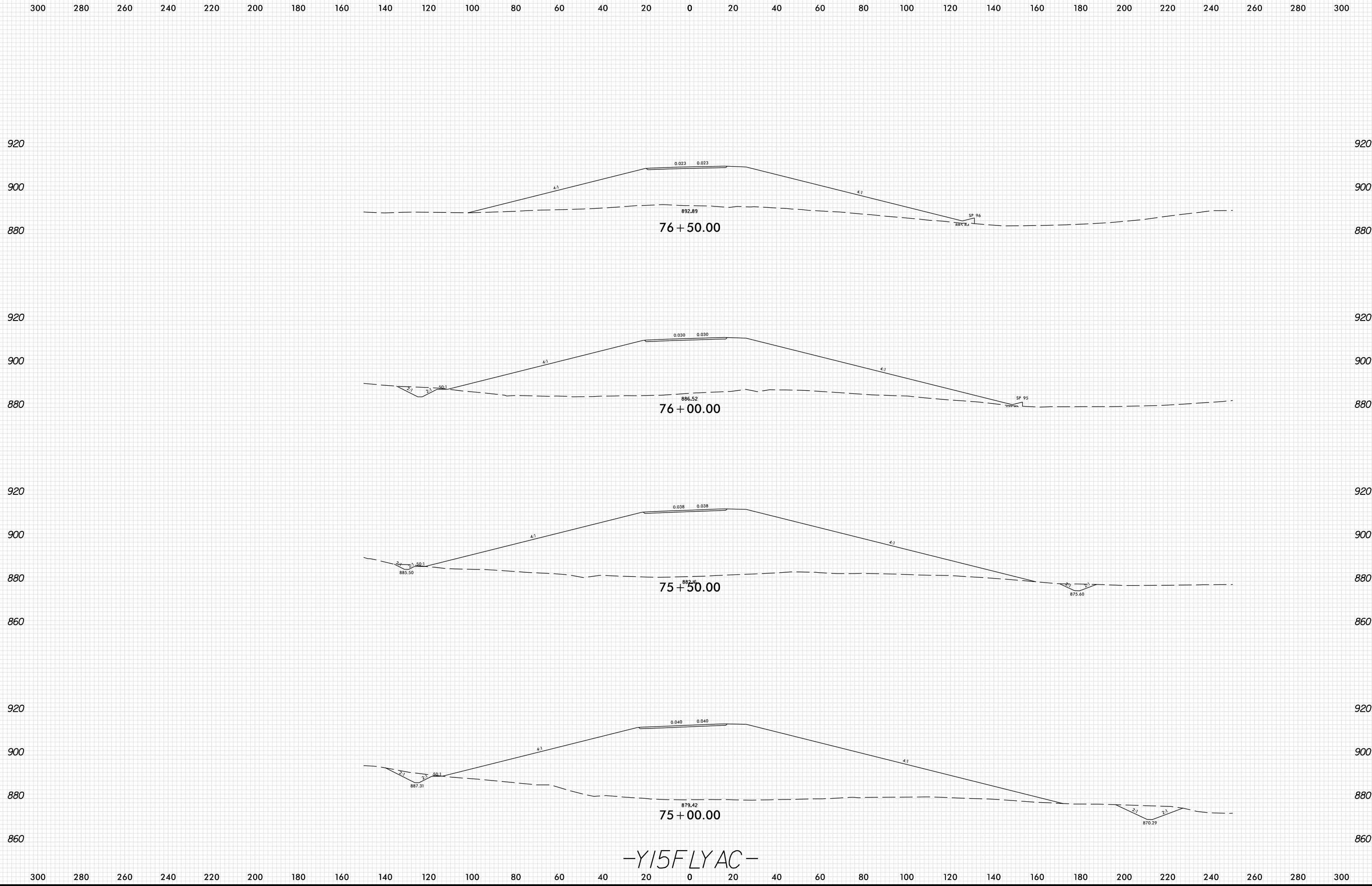

-Y15FLYAC-

PLOT DRIVER: NCD01\_pdf\_color\_eng\_100.plt  
 USER: SPEREIRA  
 DATE: 6/10/2021  
 TIME: 2:26:10 PM

8/23/99

0 10 20	PROJ. REFERENCE NO.	SHEET NO.
	U-2579AB	X-434

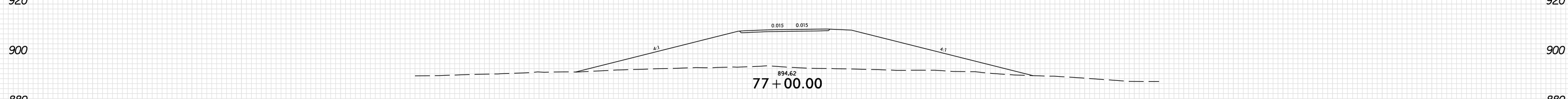
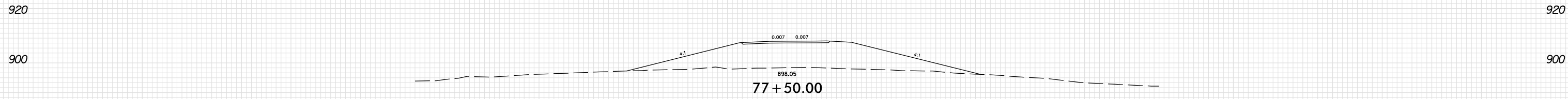
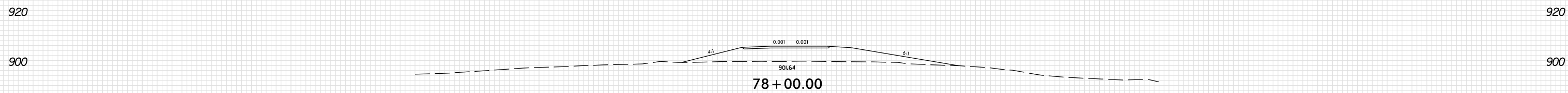
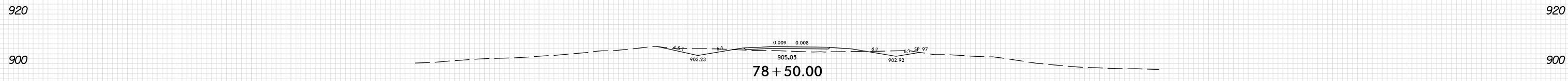
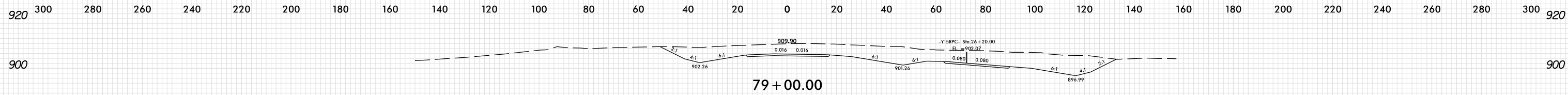

-Y15FLYAC-

PLOT DRIVER: NCD01\_pdf\_color\_eng\_100.plt  
USER: SPEREIRA  
DATE: 6/10/2021  
TIME: 2:26:11 PM  
FILE: \

300 280 260 240 220 200 180 160 140 120 100 80 60 40 20 0 20 40 60 80 100 120 140 160 180 200 220 240 260 280 300

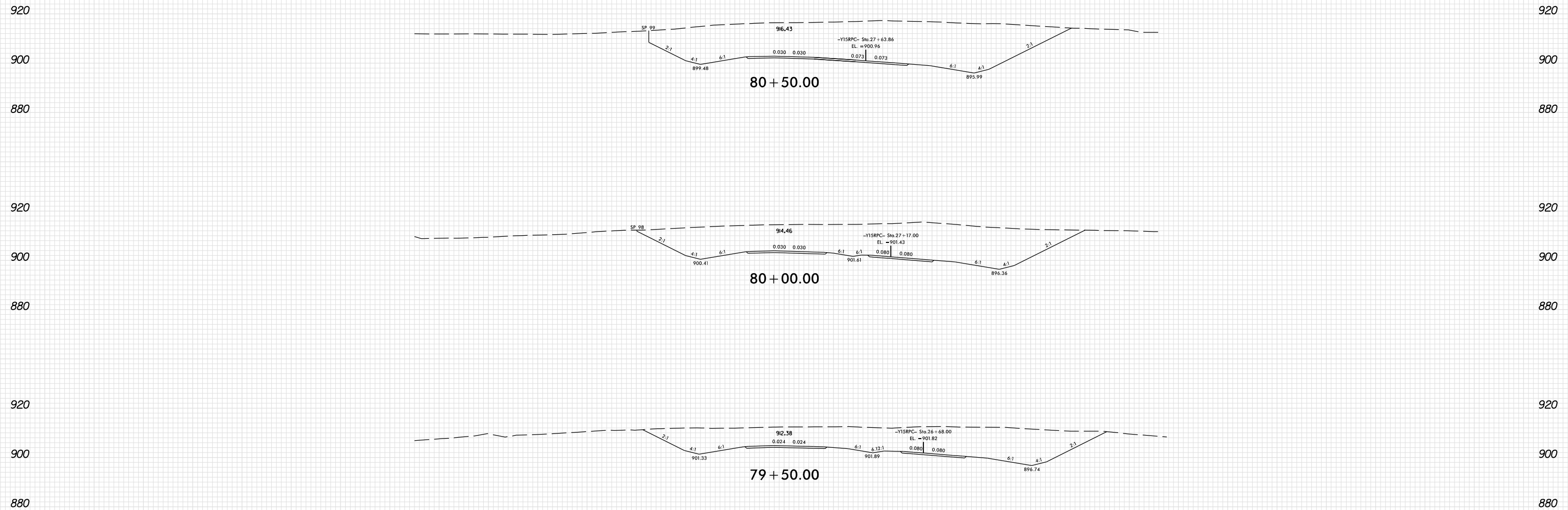

-Y15FLYAC-

300 280 260 240 220 200 180 160 140 120 100 80 60 40 20 0 20 40 60 80 100 120 140 160 180 200 220 240 260 280 300

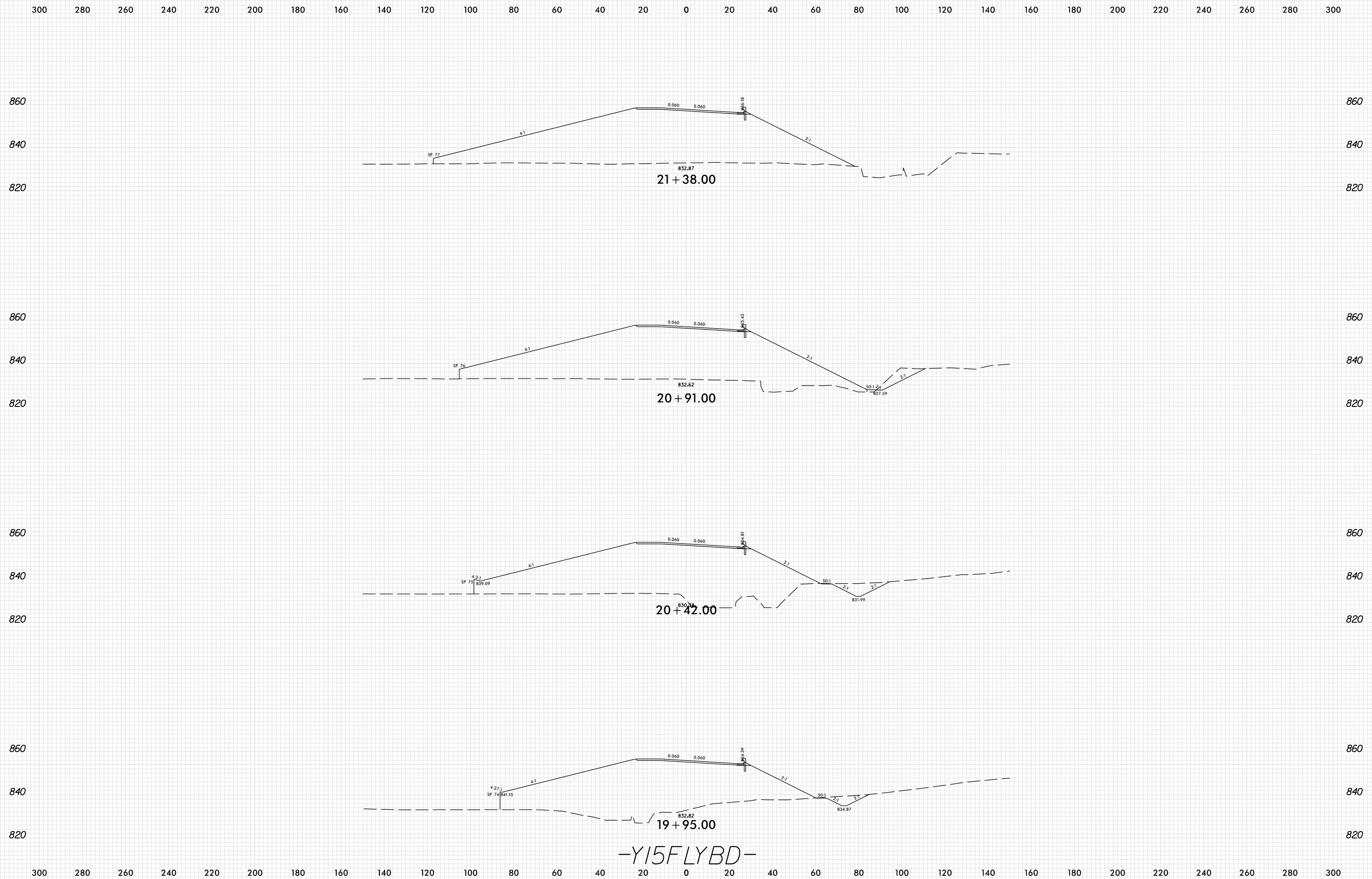

-Y15FLYBD-



8/23/99

0 10 20	PROJ. REFERENCE NO.	SHEET NO.
	U-2579AB	X-437

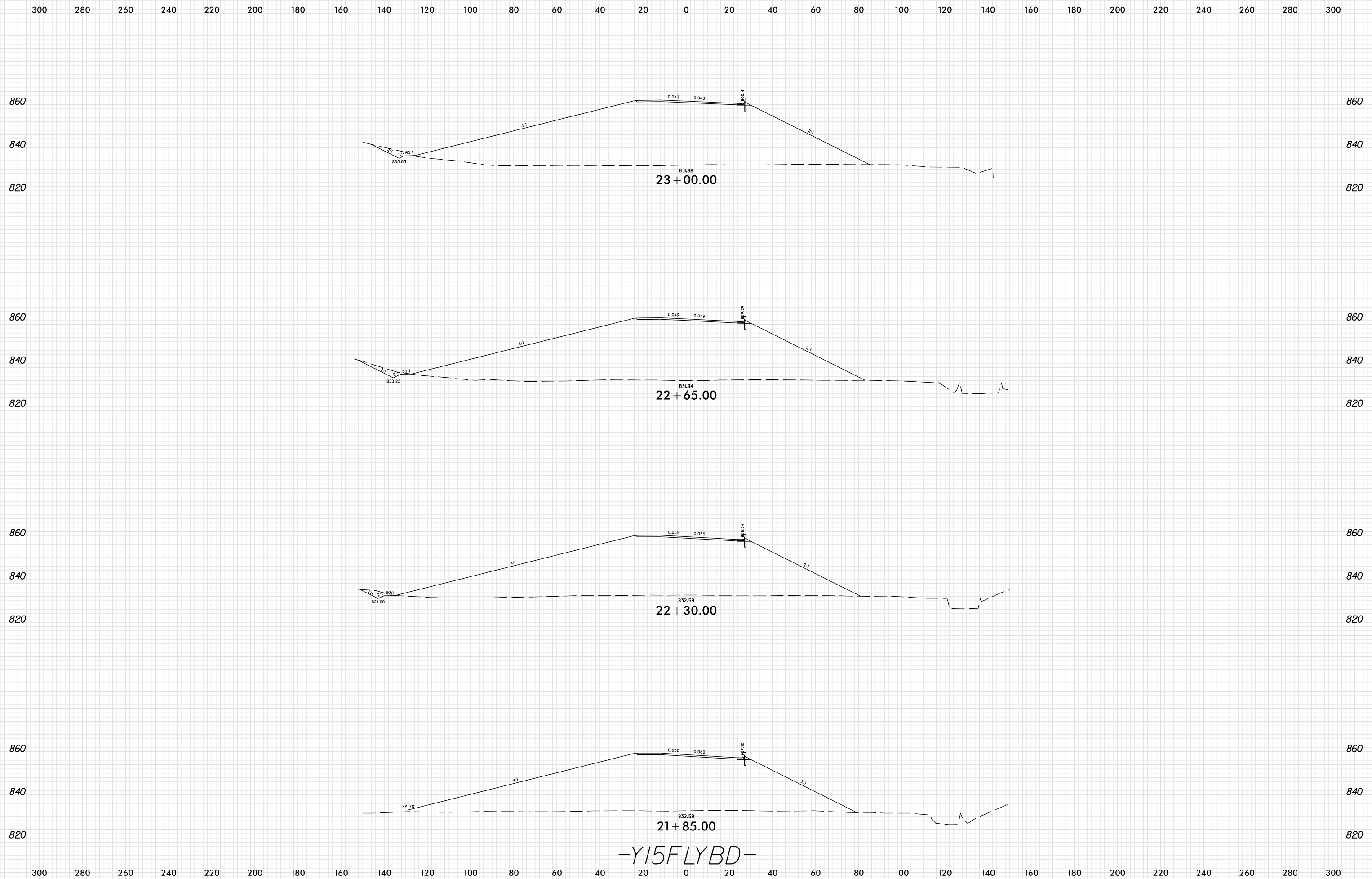

-Y15FLYBD-

PLOT DRIVER: NCDOT\_pdf\_color\_eng\_100.plt  
 USER: SPEREIRA  
 DATE: 6/10/2021  
 TIME: 2:26:42 PM

8/23/99

0 10 20	PROJ. REFERENCE NO.	SHEET NO.
	U-2579AB	X-438

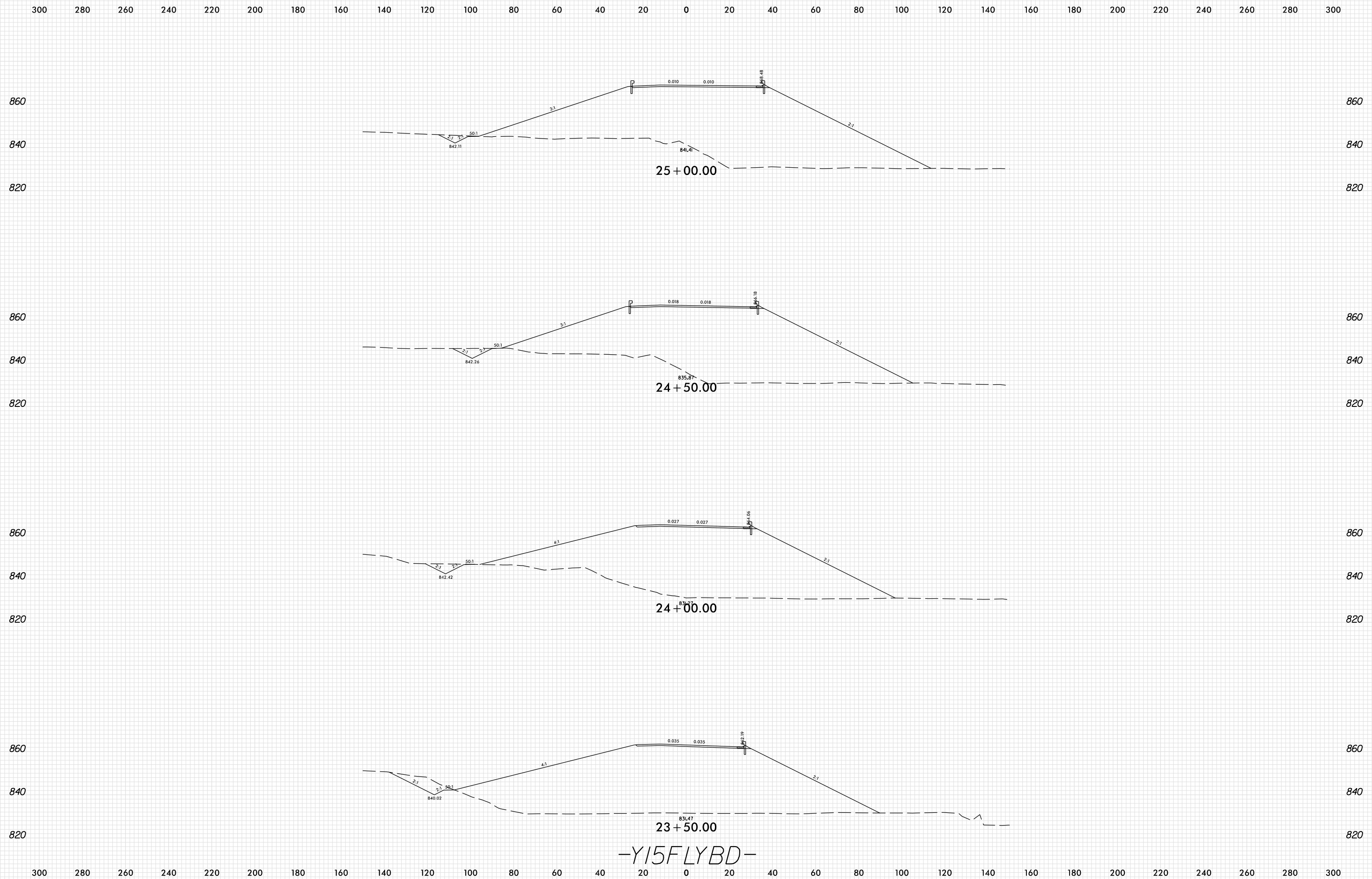

-Y15FLYBD-

PLOT DRIVER: NCD01\_pdf\_color\_eng\_100.plt  
 USER: SPEREIRA  
 DATE: 6/10/2021  
 TIME: 2:26:43 PM

FILE: \

8/23/99

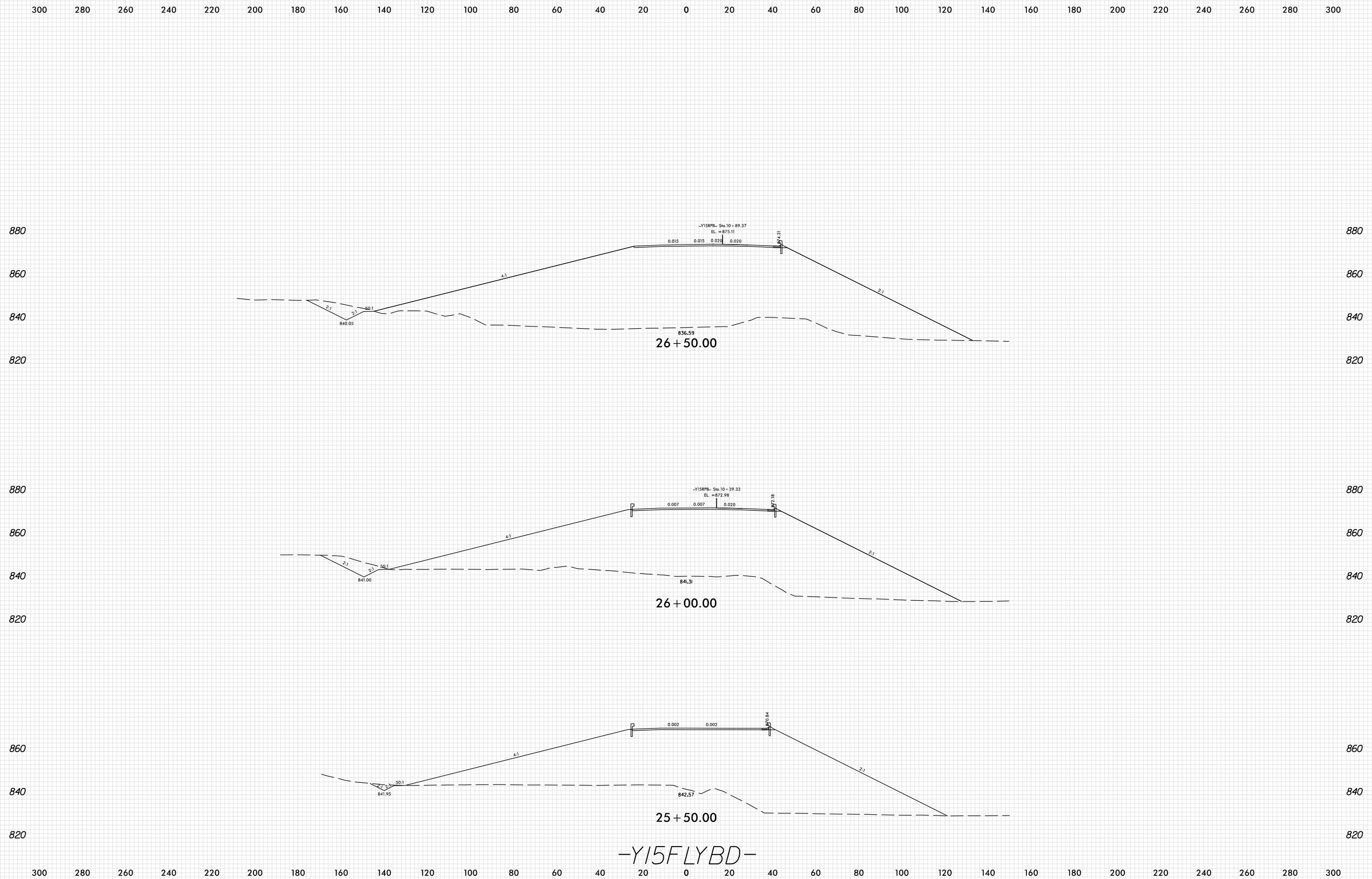

PLOT DRIVER: NCD01\_pdf\_color\_eng\_100.plt  
 USER: SPEREIRA  
 DATE: 6/10/2021  
 TIME: 2:26:43 PM  
 FILE: \

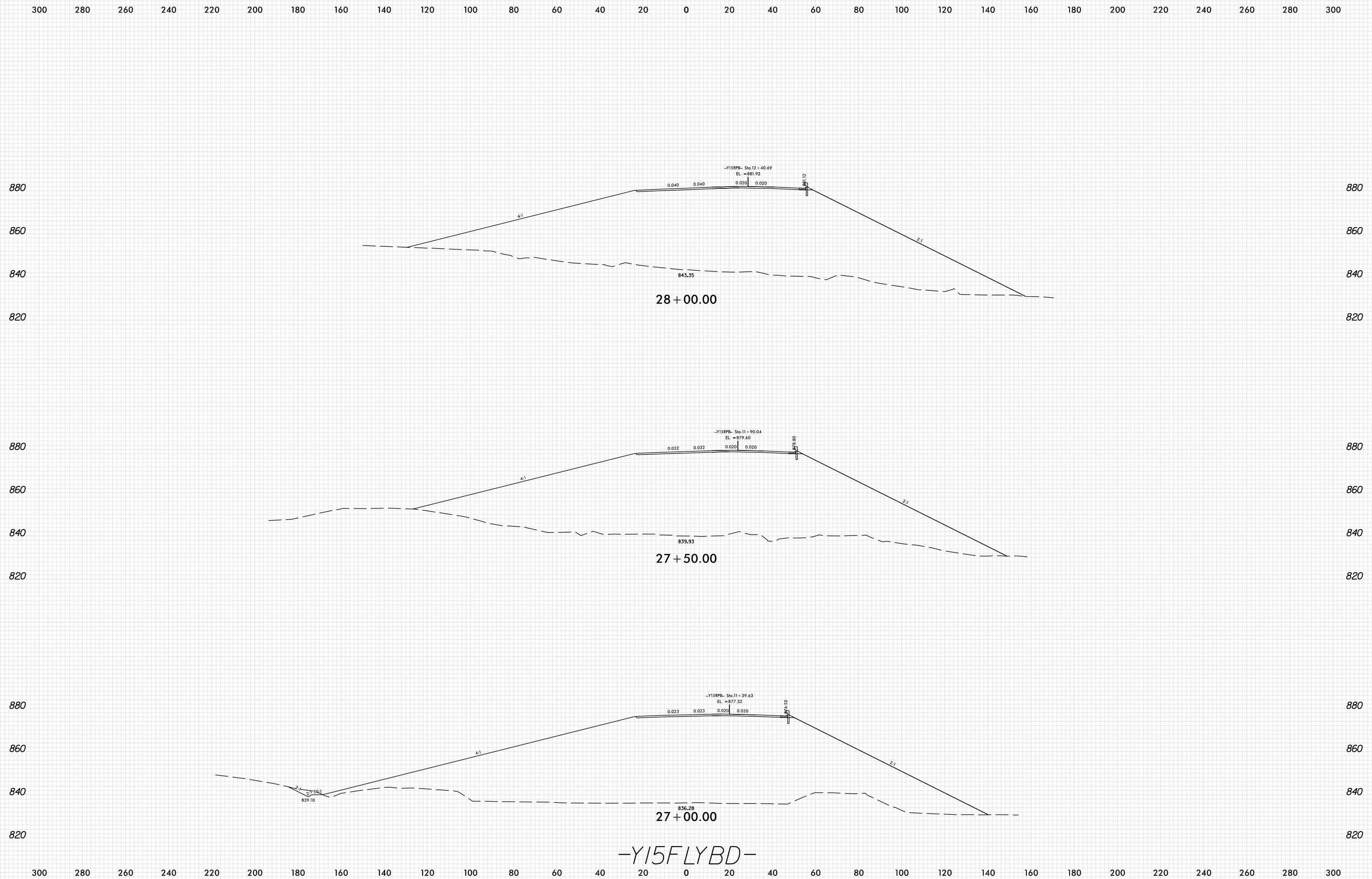

8/23/99

0 10 20	PROJ. REFERENCE NO.	SHEET NO.
	U-2579AB	X-441

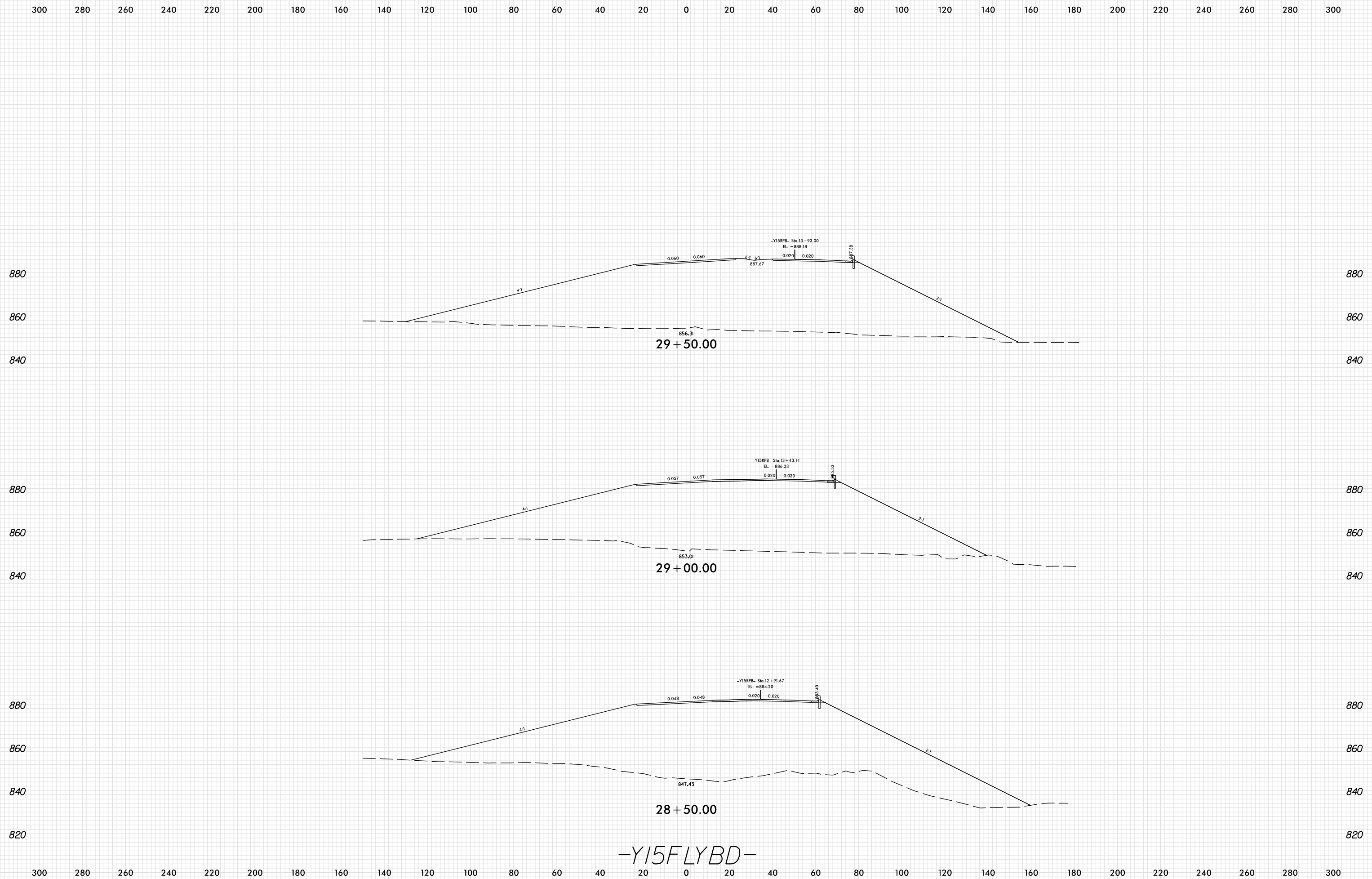

PLOT DRIVER: NCD01\_pdf\_color\_eng\_100.plt  
 USER: SPEREIRA  
 DATE: 6/10/2021  
 TIME: 2:26:45 PM  
 FILE: \

8/23/99

0 10 20	PROJ. REFERENCE NO.	SHEET NO.
	U-2579AB	X-442

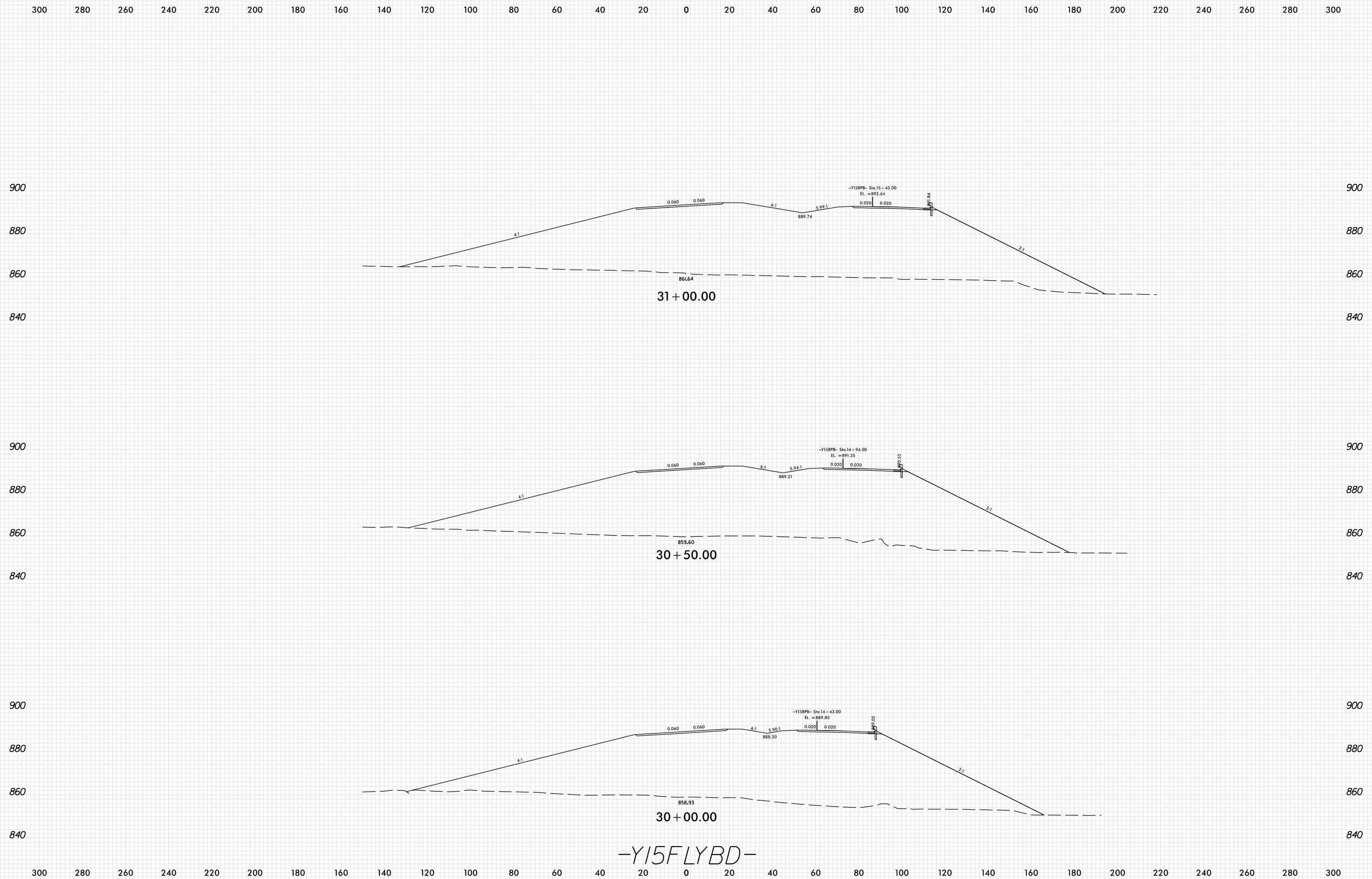

-Y15FLYBD-

PLOT DRIVER: NCD01\_pdf\_color\_eng\_100.plt  
 USER: SPEREIRA  
 DATE: 6/10/2021  
 TIME: 2:26:46 PM

8/23/99

0 10 20	PROJ. REFERENCE NO.	SHEET NO.
	U-2579AB	X-443

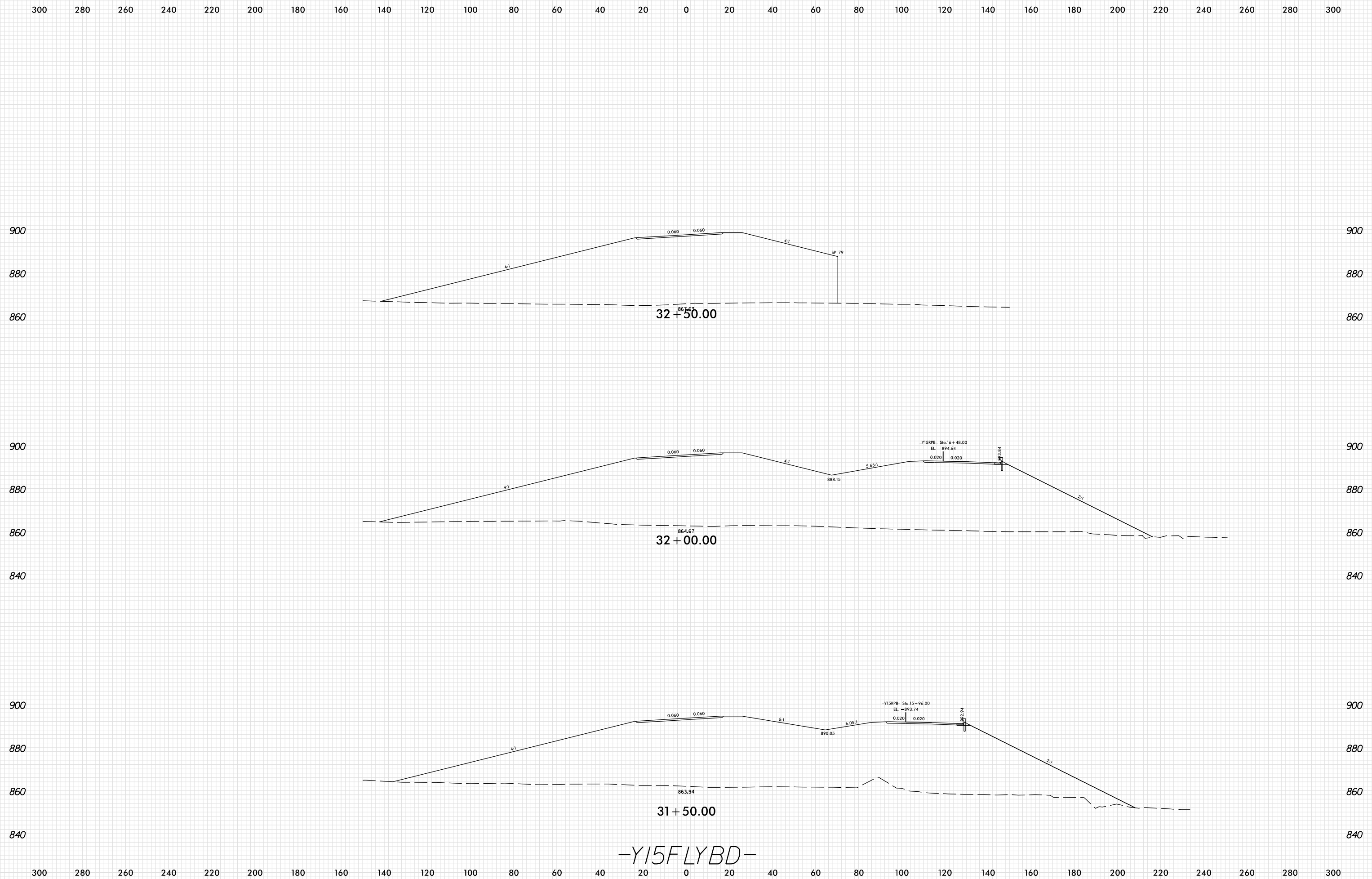

-Y15FLYBD-

PLOT DRIVER: NCD01\_pdf\_color\_eng\_100.plt  
 USER: SPEREIRA  
 DATE: 6/10/2021  
 TIME: 2:26:46 PM

8/23/99

0 10 20	PROJ. REFERENCE NO.	SHEET NO.
	U-2579AB	X-444

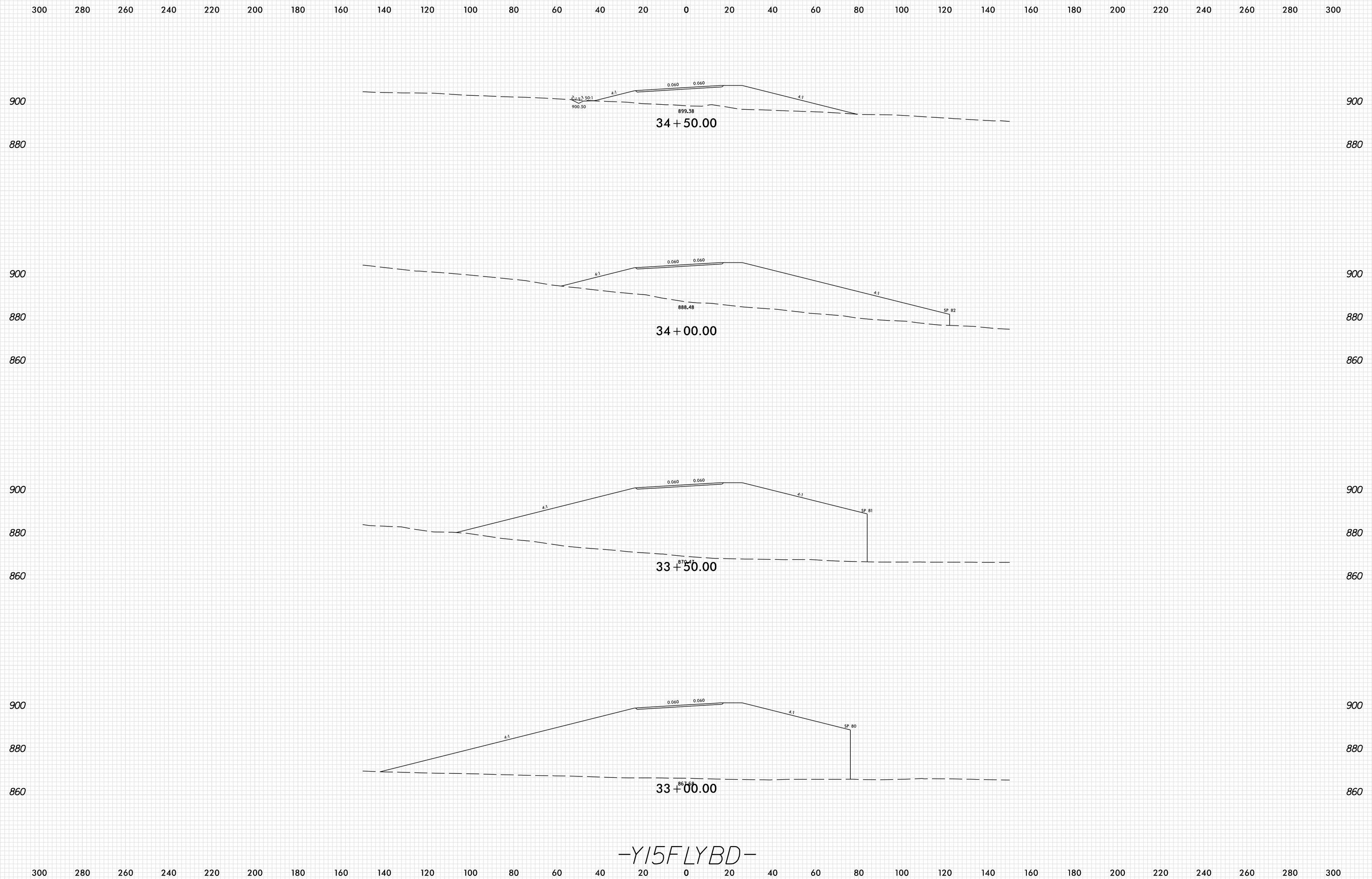

-Y15FLYBD-

PLOT DRIVER: NCD01\_pdf\_color\_eng\_100.plt  
 USER: SPEREIRA  
 DATE: 6/10/2021  
 TIME: 2:26:47 PM  
 FILE: \



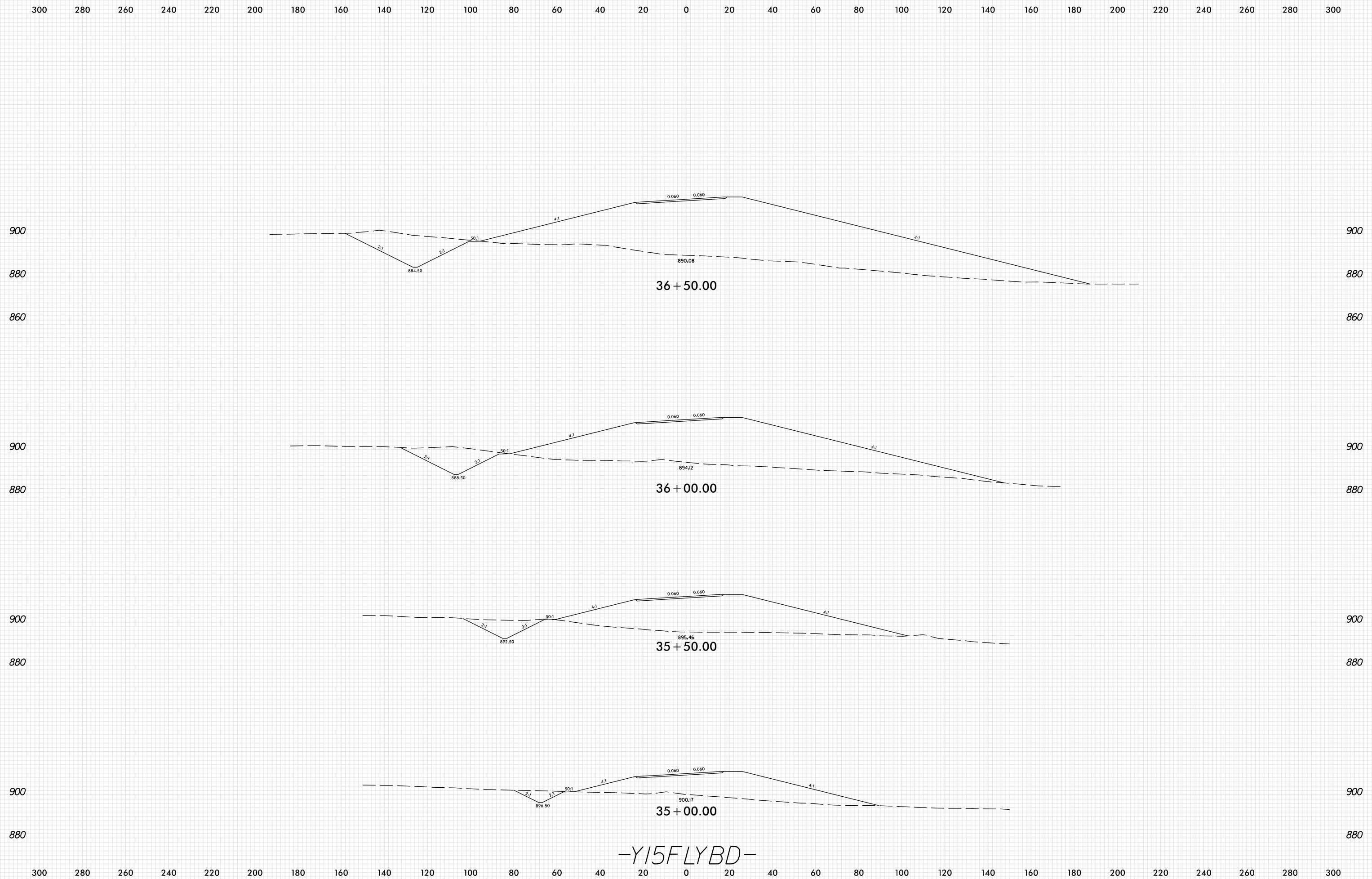

8/23/99

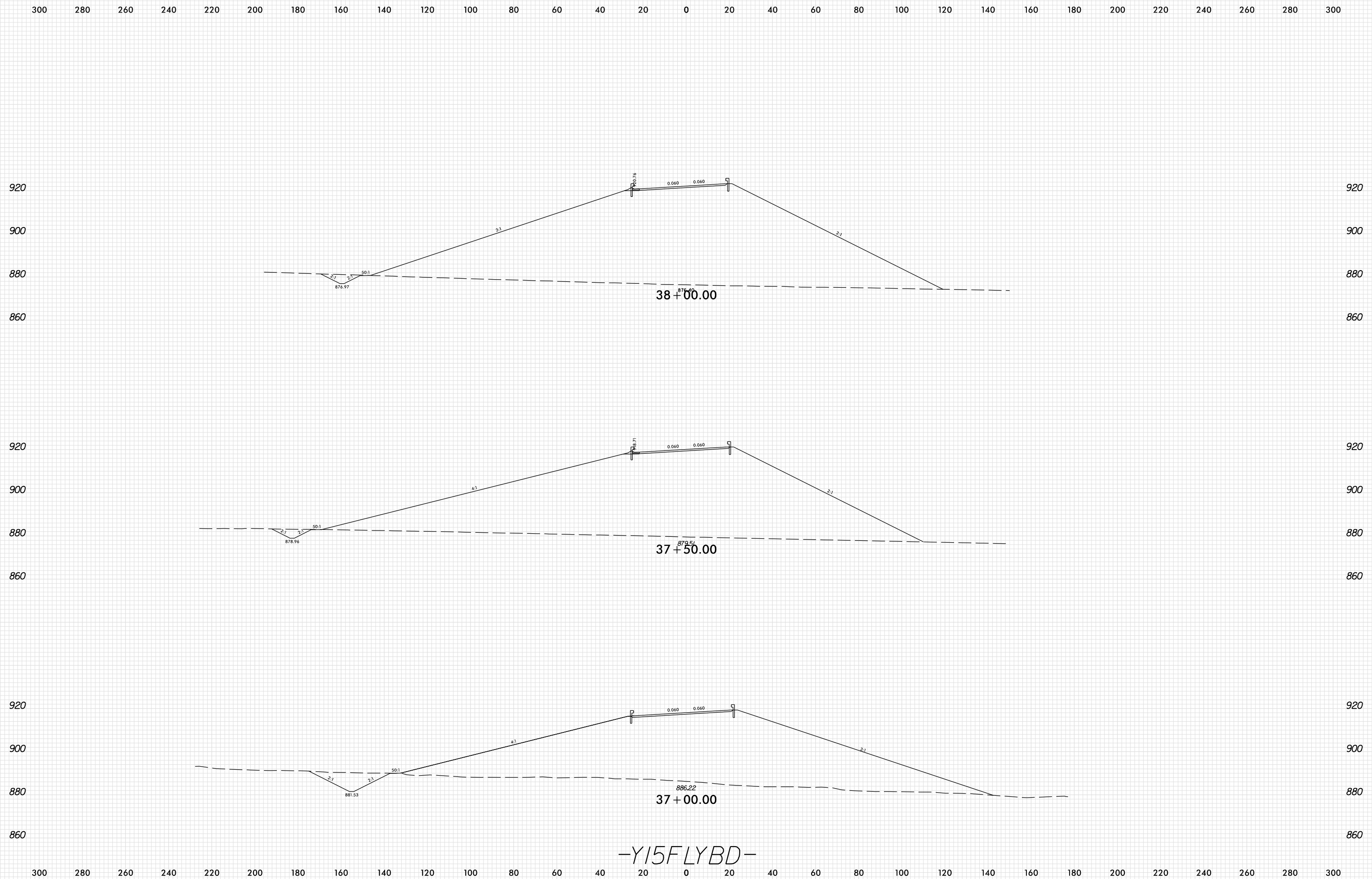

PLOT DRIVER: NCDOT\_pdf\_color\_eng\_100.plt  
 USER: SPEREIRA  
 DATE: 6/10/2021  
 TIME: 2:26:48 PM  
 FILE: \

300 280 260 240 220 200 180 160 140 120 100 80 60 40 20 0 20 40 60 80 100 120 140 160 180 200 220 240 260 280 300

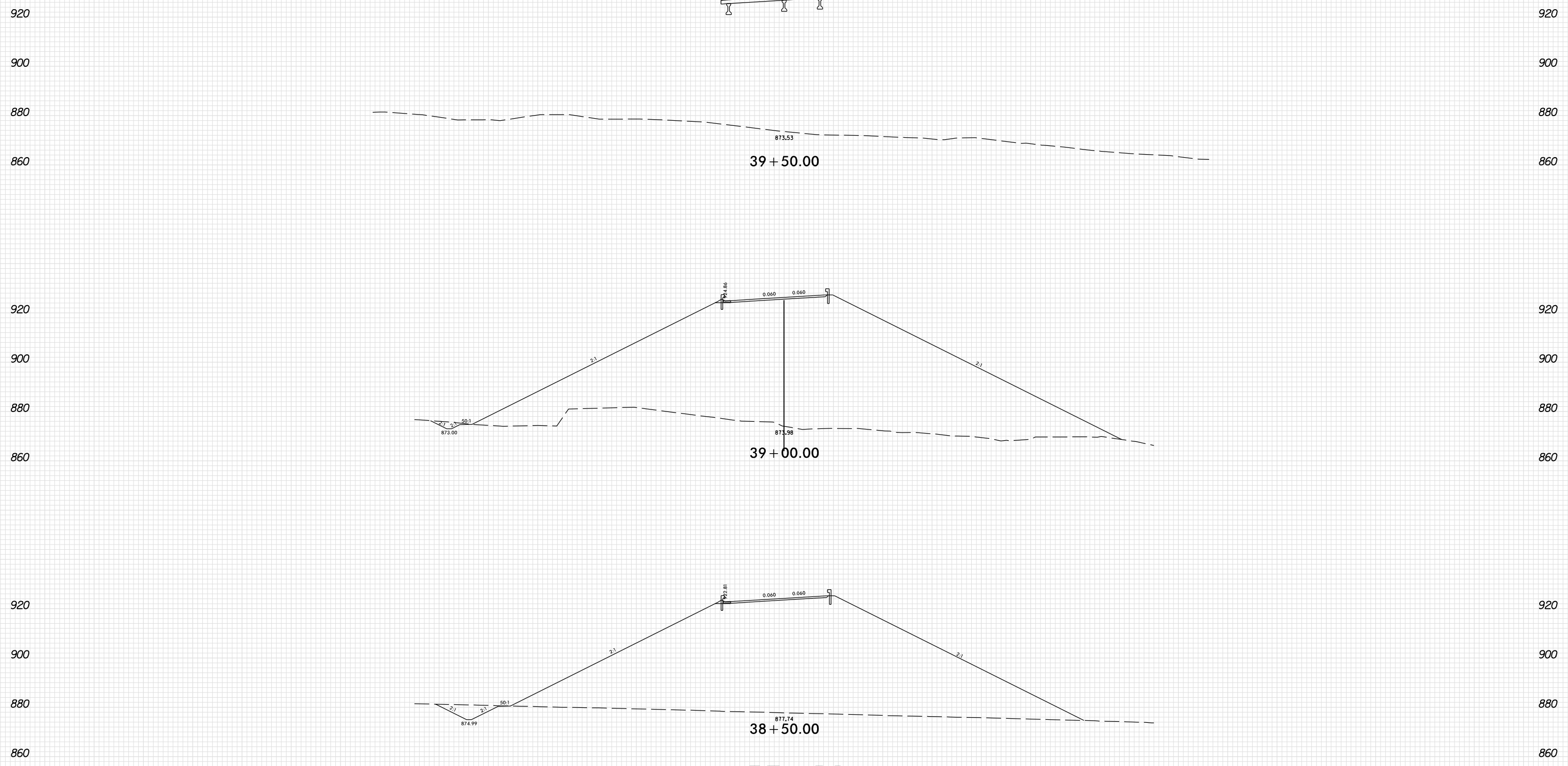

-Y15FLYBD-

8/23/99

0 10 20	PROJ. REFERENCE NO.	SHEET NO.
	U-2579AB	X-448

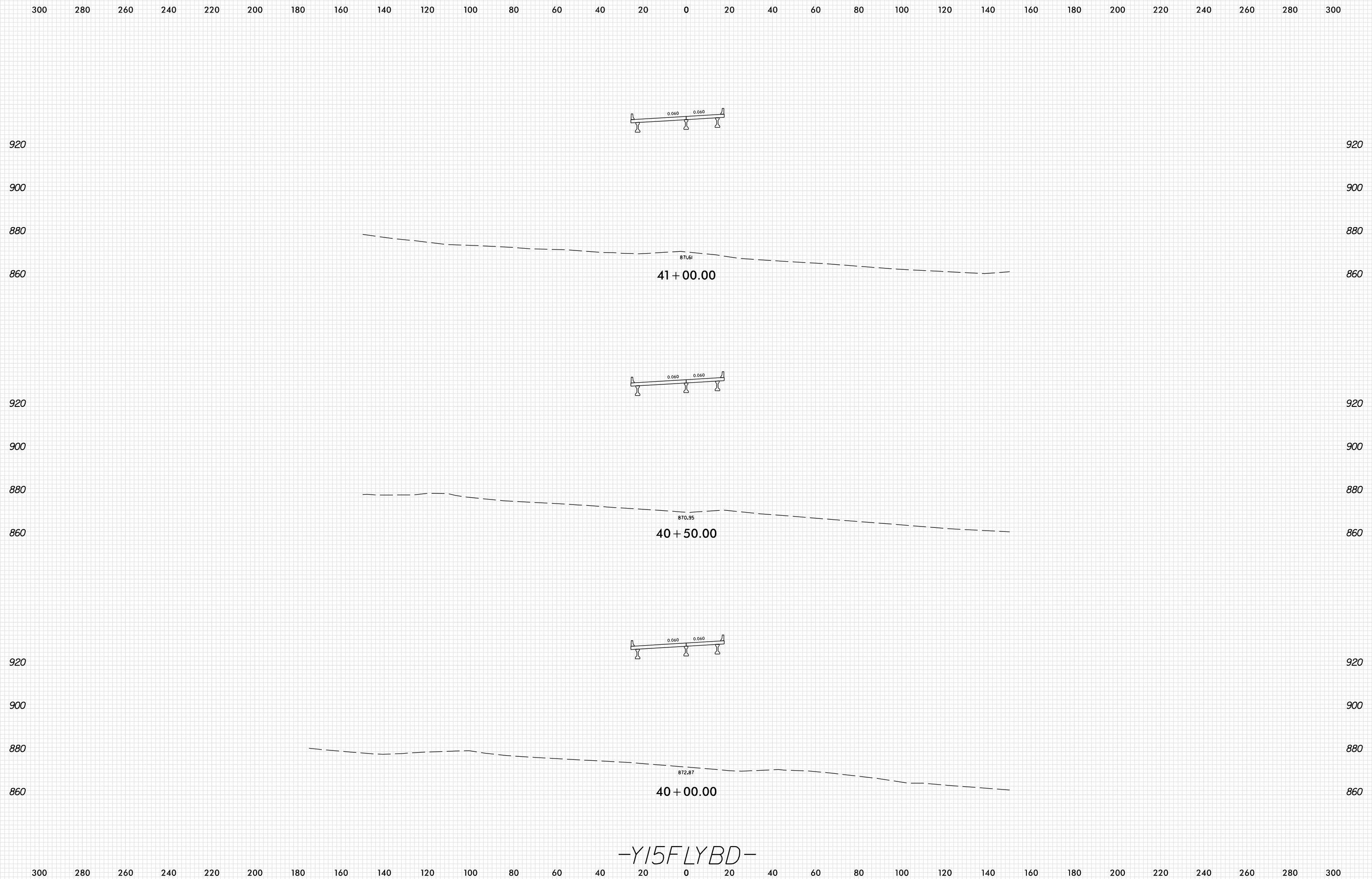

-Y15FLYBD-

PLOT DRIVER: NCDOT\_pdf\_color\_eng\_100.plt  
 USER: SPEREIRA  
 DATE: 6/10/2021  
 TIME: 2:26:50 PM  
 FILE: \

8/23/99

0 10 20	PROJ. REFERENCE NO.	SHEET NO.
	U-2579AB	X-449

300 280 260 240 220 200 180 160 140 120 100 80 60 40 20 0 20 40 60 80 100 120 140 160 180 200 220 240 260 280 300

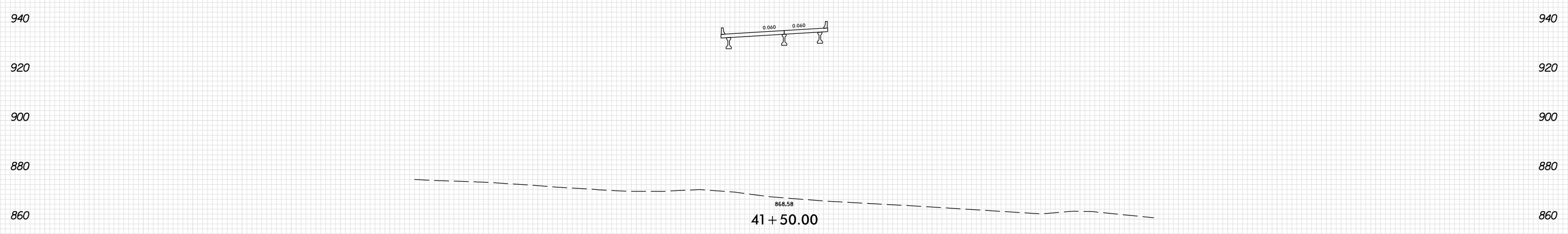
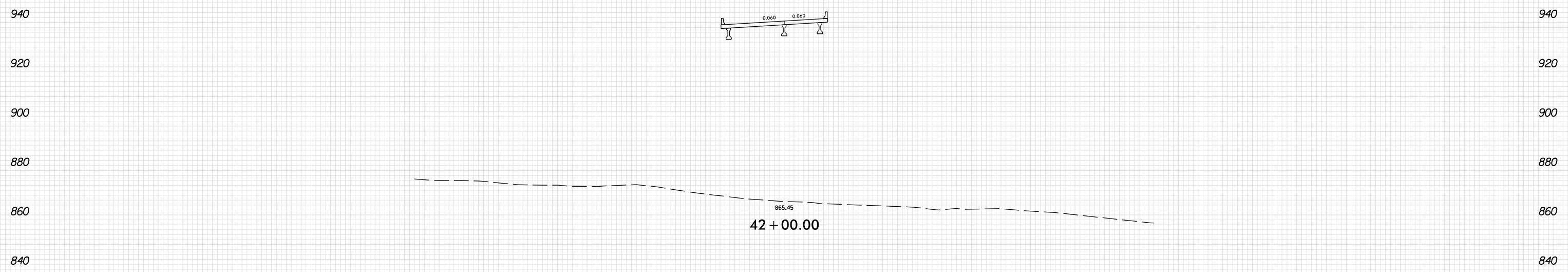

-Y15FLYBD-

300 280 260 240 220 200 180 160 140 120 100 80 60 40 20 0 20 40 60 80 100 120 140 160 180 200 220 240 260 280 300

PLOT DRIVER: NCDOT\_pdf\_color\_eng\_100.plt  
 USER: SPEREIRA  
 DATE: 6/10/2021  
 TIME: 2:26:50 PM  
 FILE: \

300 280 260 240 220 200 180 160 140 120 100 80 60 40 20 0 20 40 60 80 100 120 140 160 180 200 220 240 260 280 300

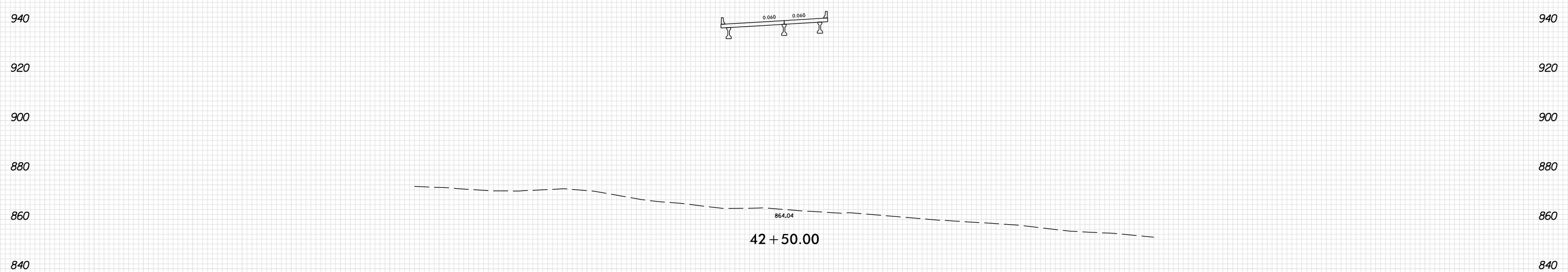
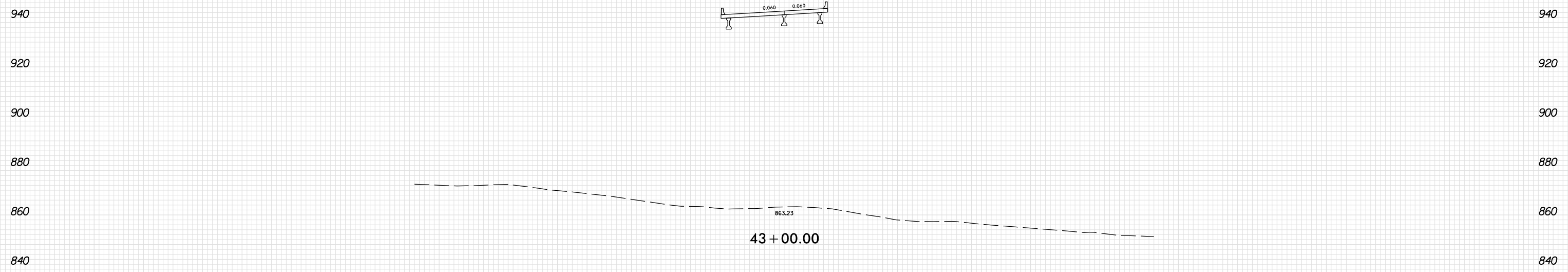

-Y15FLYBD-

300 280 260 240 220 200 180 160 140 120 100 80 60 40 20 0 20 40 60 80 100 120 140 160 180 200 220 240 260 280 300

8/23/99

0 10 20	PROJ. REFERENCE NO.	SHEET NO.
	U-2579AB	X-451

300 280 260 240 220 200 180 160 140 120 100 80 60 40 20 0 20 40 60 80 100 120 140 160 180 200 220 240 260 280 300

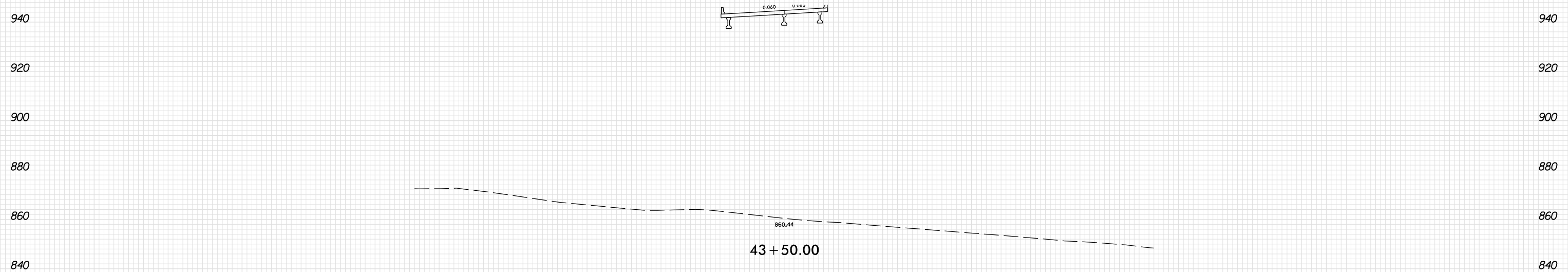
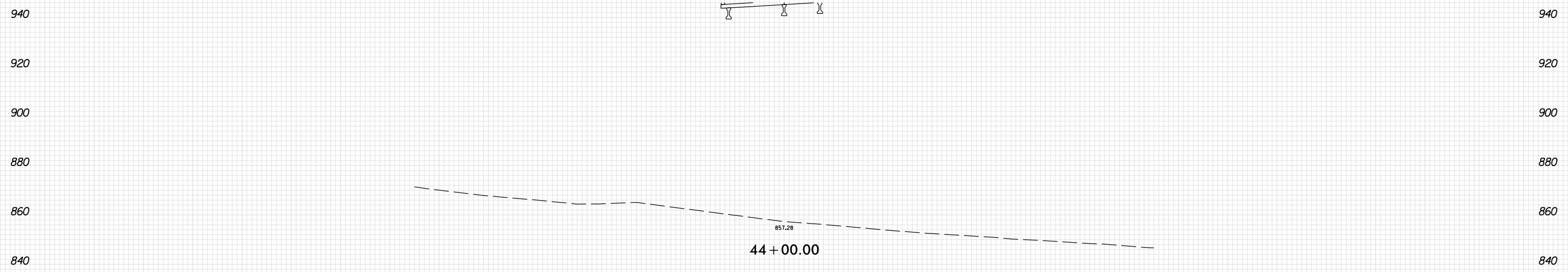

-Y15FLYBD-

PLOT DRIVER: NCDOT\_pdf\_color\_eng\_100.plt  
 USER: SPEREIRA  
 FILE: \PENTABLE; xpl\_en\_v8.tbl  
 DATE: 6/10/2021  
 TIME: 2:26:51 PM

300 280 260 240 220 200 180 160 140 120 100 80 60 40 20 0 20 40 60 80 100 120 140 160 180 200 220 240 260 280 300

8/23/99

0 10 20	PROJ. REFERENCE NO.	SHEET NO.
	U-2579AB	X-452

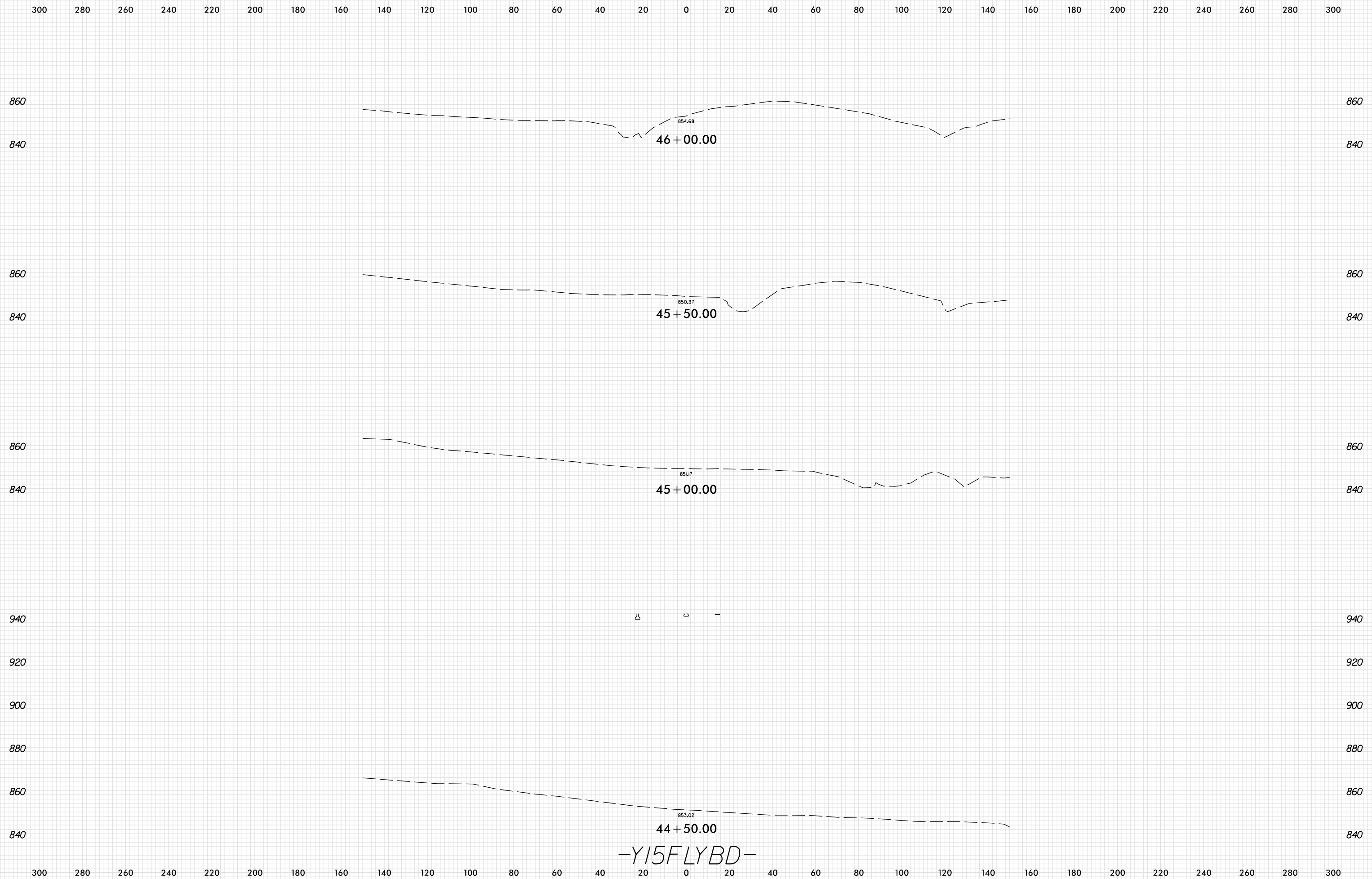

PLOT DRIVER: NCD01\_.pdf\_color\_eng\_100.plt  
 USER: SPEREIRA  
 DATE: 6/10/2021  
 TIME: 2:26:52 PM  
 FILE: \

-Y15FLYBD-



8/23/99

0 10 20	PROJ. REFERENCE NO.	SHEET NO.
	U-2579AB	X-453

300 280 260 240 220 200 180 160 140 120 100 80 60 40 20 0 20 40 60 80 100 120 140 160 180 200 220 240 260 280 300

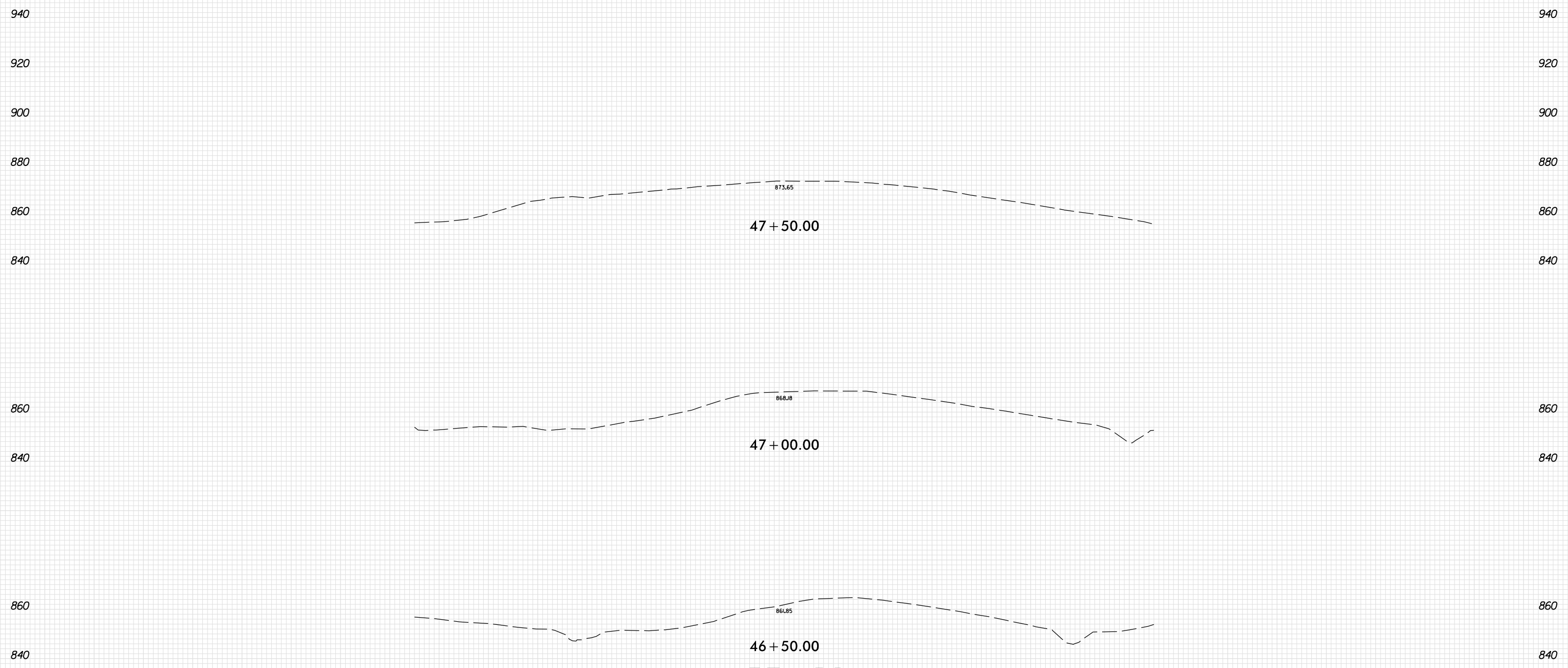

-Y15FLYBD-

PLOT DRIVER: NCDOT\_pdf\_color\_eng\_100.plt  
 USER: SPEREIRA  
 FILE: \PENTABLE; xpl\_en\_v8.tbl  
 DATE: 6/10/2021  
 TIME: 2:26:52 PM

8/23/99

0 10 20	PROJ. REFERENCE NO.	SHEET NO.
	U-2579AB	X-454

300 280 260 240 220 200 180 160 140 120 100 80 60 40 20 0 20 40 60 80 100 120 140 160 180 200 220 240 260 280 300

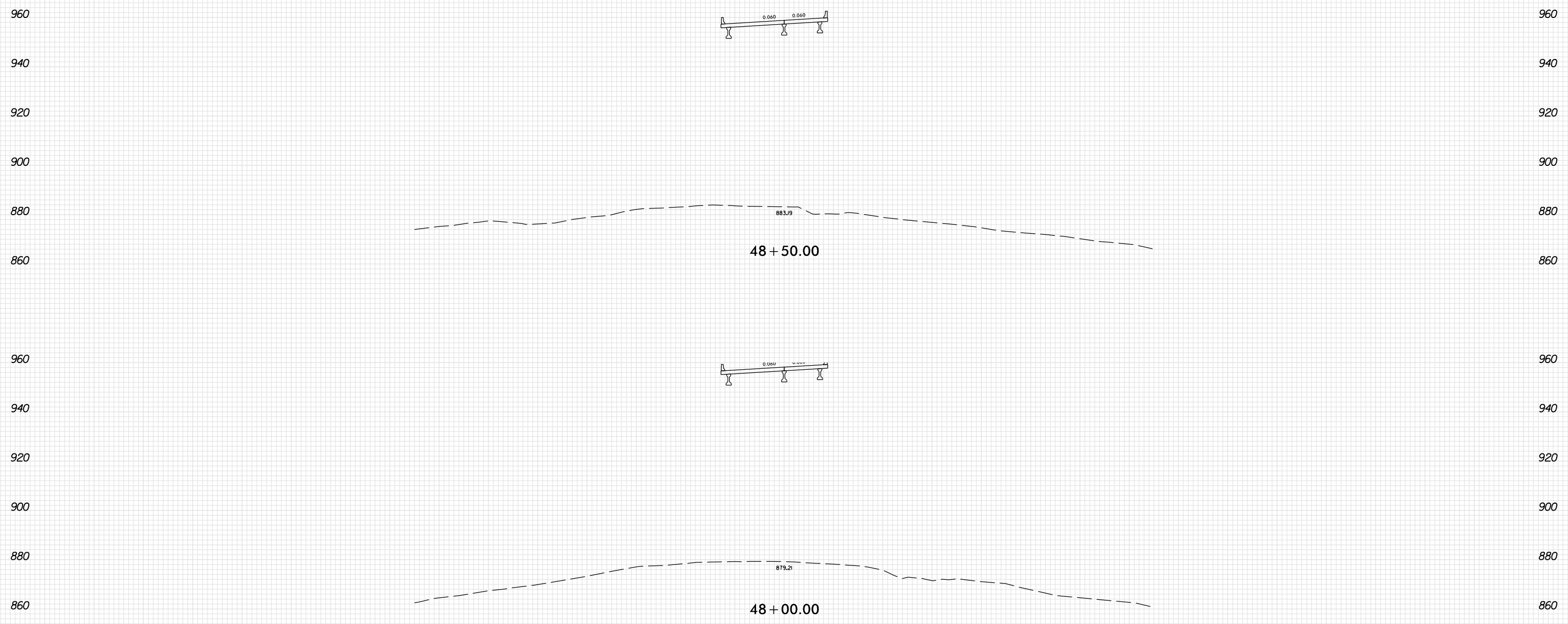

PLOT DRIVER: NCD01\_pdf\_color\_eng\_100.plt  
 USER: SPEREIRA  
 DATE: 6/10/2021  
 TIME: 2:26:53 PM

300 280 260 240 220 200 180 160 140 120 100 80 60 40 20 0 20 40 60 80 100 120 140 160 180 200 220 240 260 280 300

300 280 260 240 220 200 180 160 140 120 100 80 60 40 20 0 20 40 60 80 100 120 140 160 180 200 220 240 260 280 300

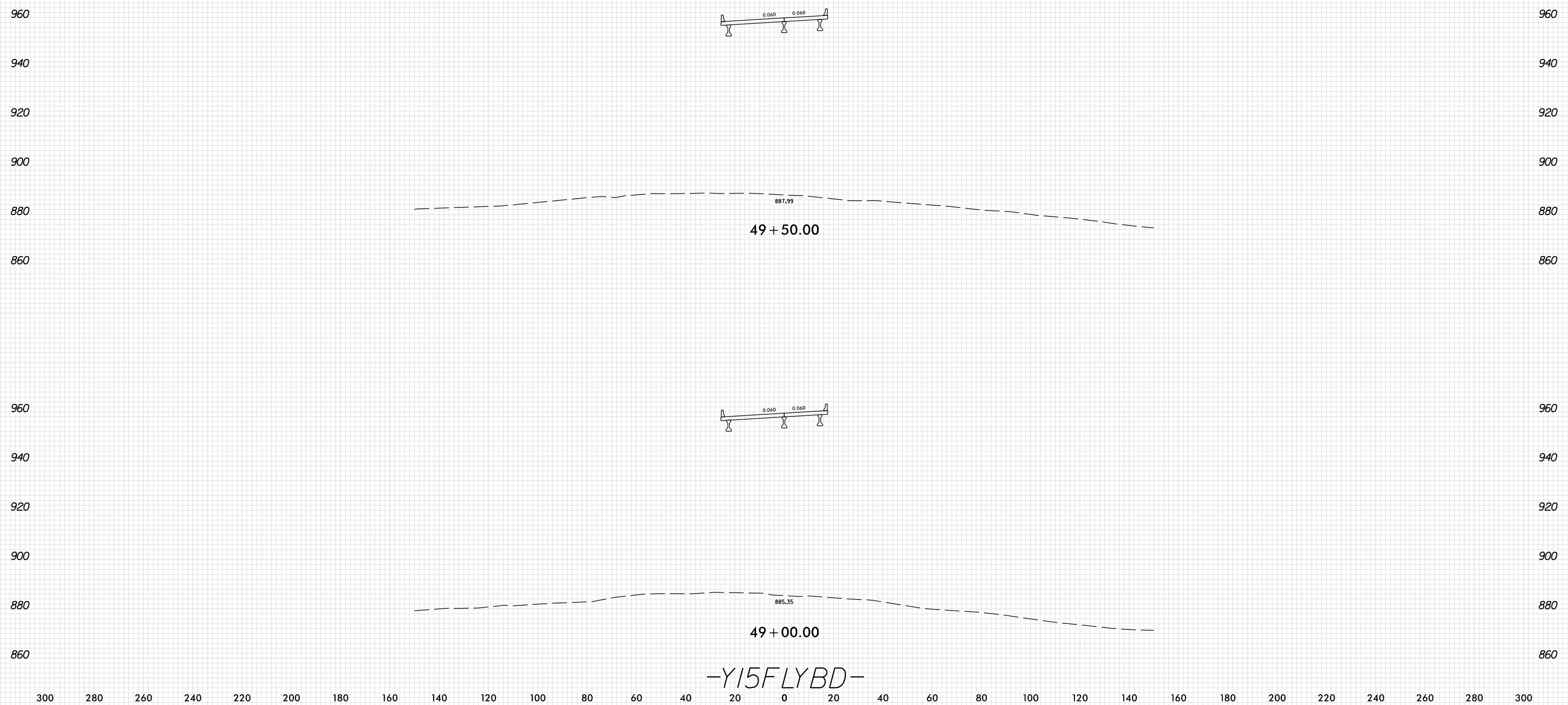

-Y15FLYBD-

8/23/99

0 10 20	PROJ. REFERENCE NO.	SHEET NO.
	U-2579AB	X-456

300 280 260 240 220 200 180 160 140 120 100 80 60 40 20 0 20 40 60 80 100 120 140 160 180 200 220 240 260 280 300

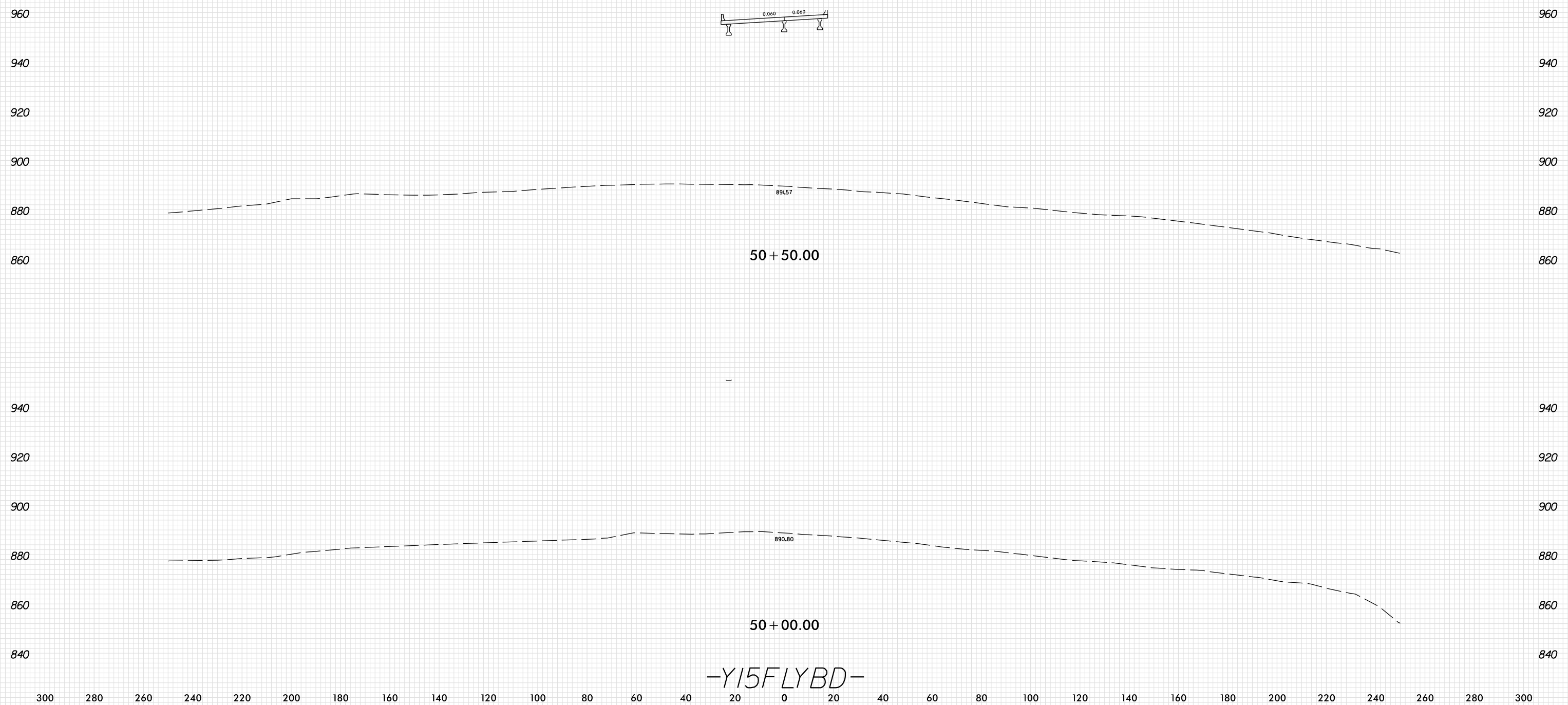

PLOT DRIVER: NCD01\_pdf\_color\_eng\_100.plt  
 USER: SPEREIRA  
 DATE: 6/10/2021  
 TIME: 2:26:54 PM  
 FILE: \

300 280 260 240 220 200 180 160 140 120 100 80 60 40 20 0 20 40 60 80 100 120 140 160 180 200 220 240 260 280 300

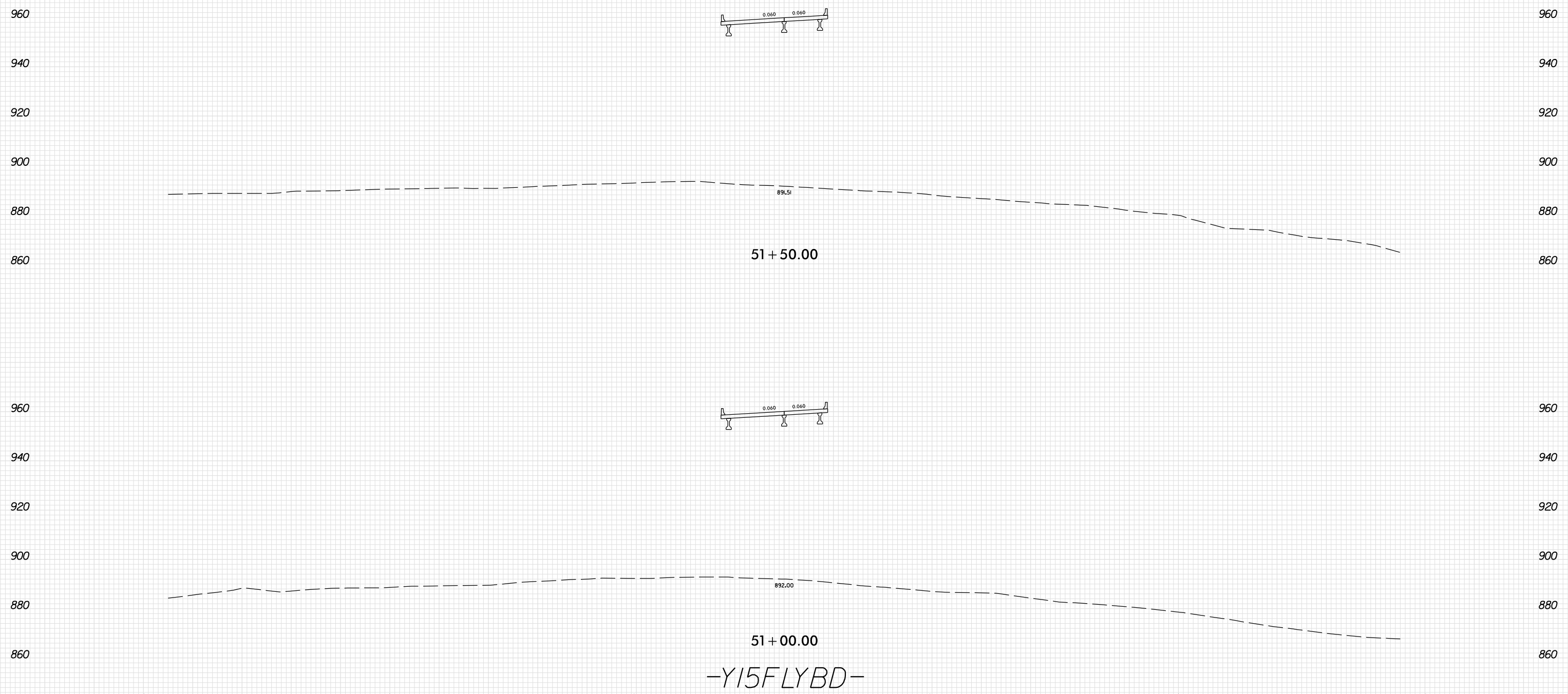

8/23/99

0 10 20	PROJ. REFERENCE NO.	SHEET NO.
	U-2579AB	X-458

300 280 260 240 220 200 180 160 140 120 100 80 60 40 20 0 20 40 60 80 100 120 140 160 180 200 220 240 260 280 300

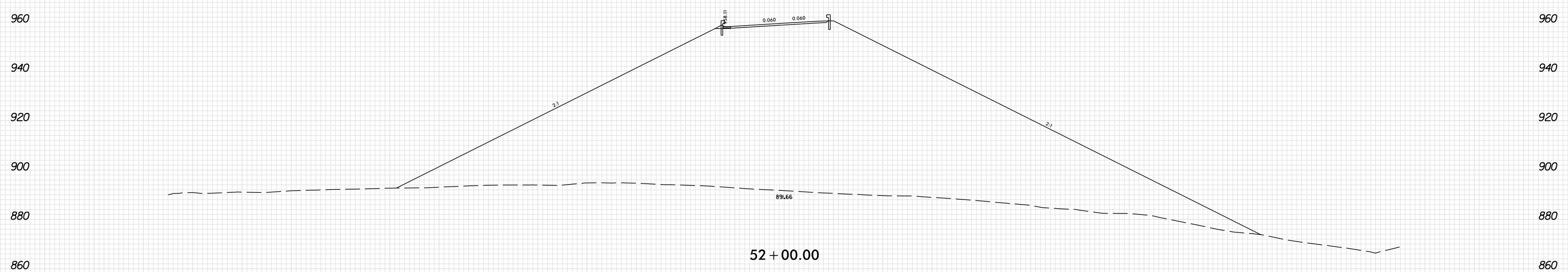
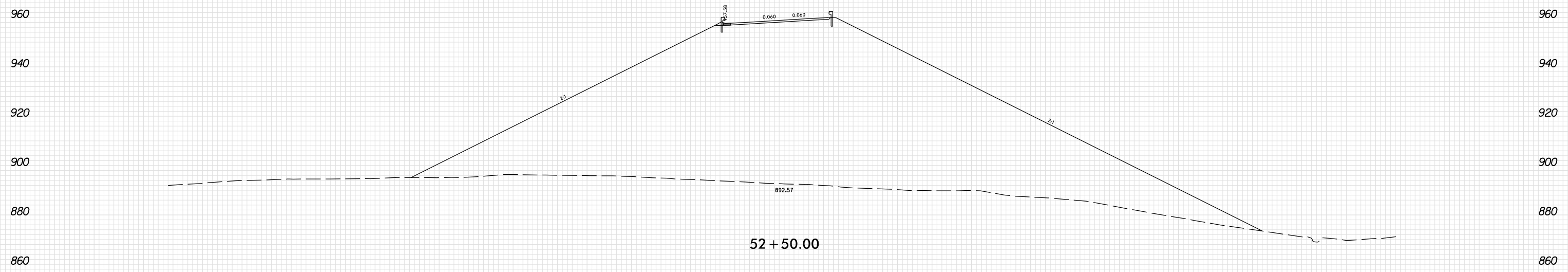

-Y15FLYBD-

300 280 260 240 220 200 180 160 140 120 100 80 60 40 20 0 20 40 60 80 100 120 140 160 180 200 220 240 260 280 300

PLOT DRIVER: NCD01\_pdf\_color\_eng\_100.plt  
 USER: SPEREIRA  
 DATE: 6/10/2021  
 TIME: 2:26:56 PM  
 FILE: \

8/23/99

0 10 20	PROJ. REFERENCE NO.	SHEET NO.
	U-2579AB	X-459

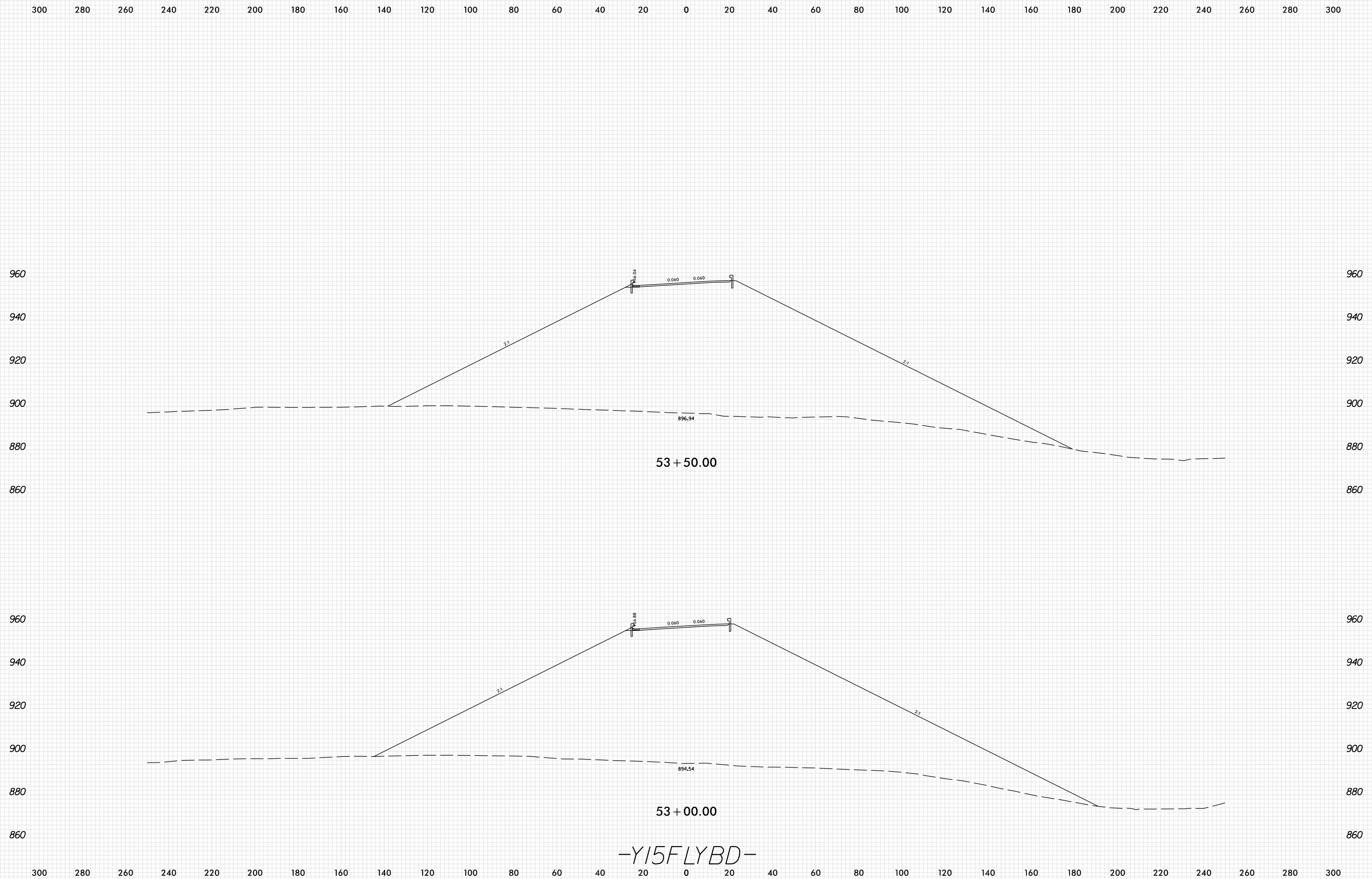

PLOT DRIVER: NCDOT\_pdf\_color\_eng\_100.plt  
 USER: SPEREIRA  
 DATE: 6/10/2021  
 TIME: 2:26:56 PM  
 FILE: \

8/23/99

0 10 20	PROJ. REFERENCE NO.	SHEET NO.
	U-2579AB	X-460

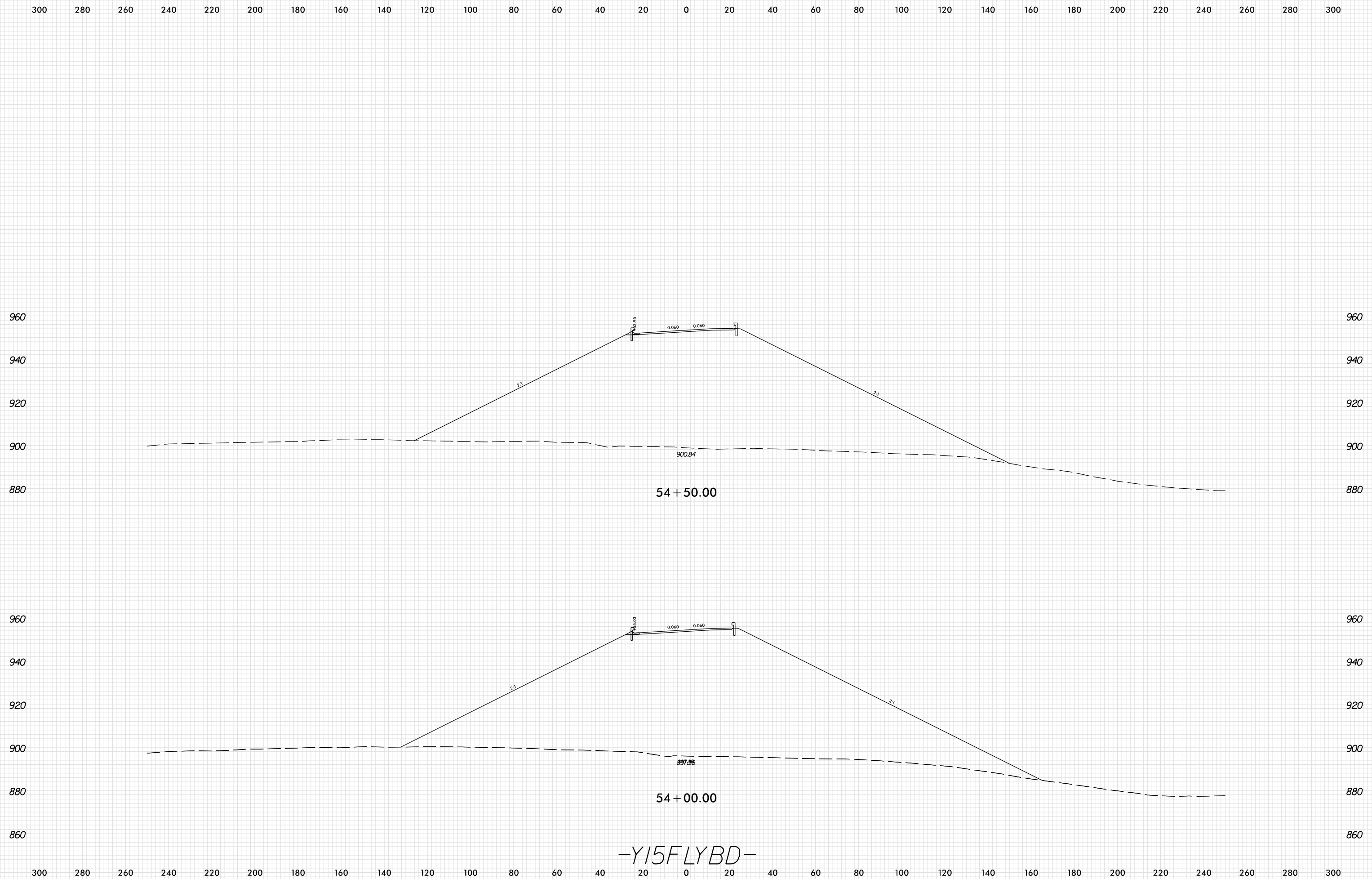

-Y15FLYBD-

PLOT DRIVER: NCDOT\_pdf\_color\_eng\_100.plt  
 USER: SPEREIRA  
 DATE: 6/10/2021  
 TIME: 2:26:57 PM  
 FILE: \



8/23/99

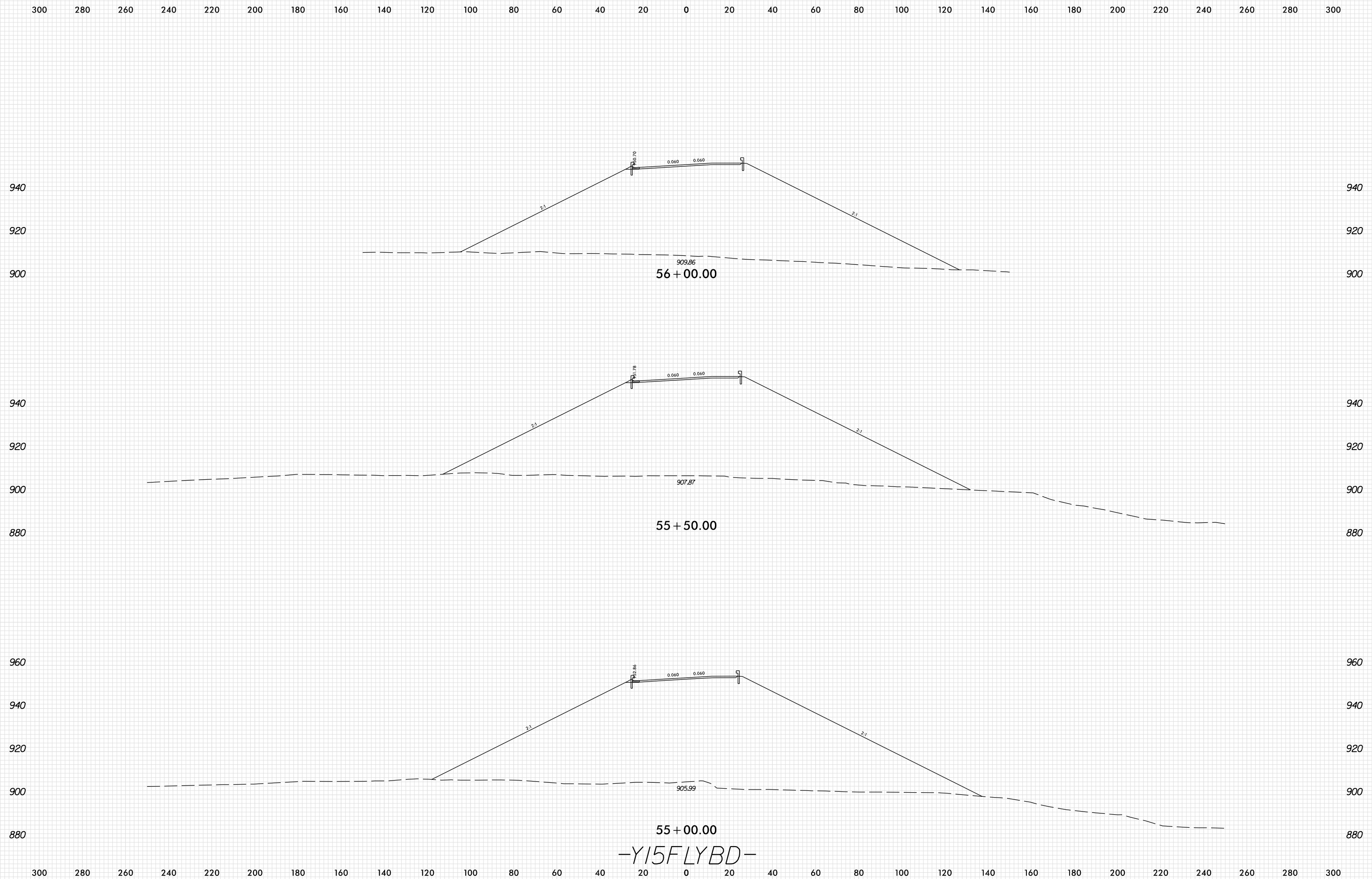

-Y15FLYBD-

PLOT DRIVER: NCD01\_pdf\_color\_eng\_100.plt  
 USER: SPEREIRA  
 DATE: 6/10/2021  
 TIME: 2:26:58 PM

8/23/99

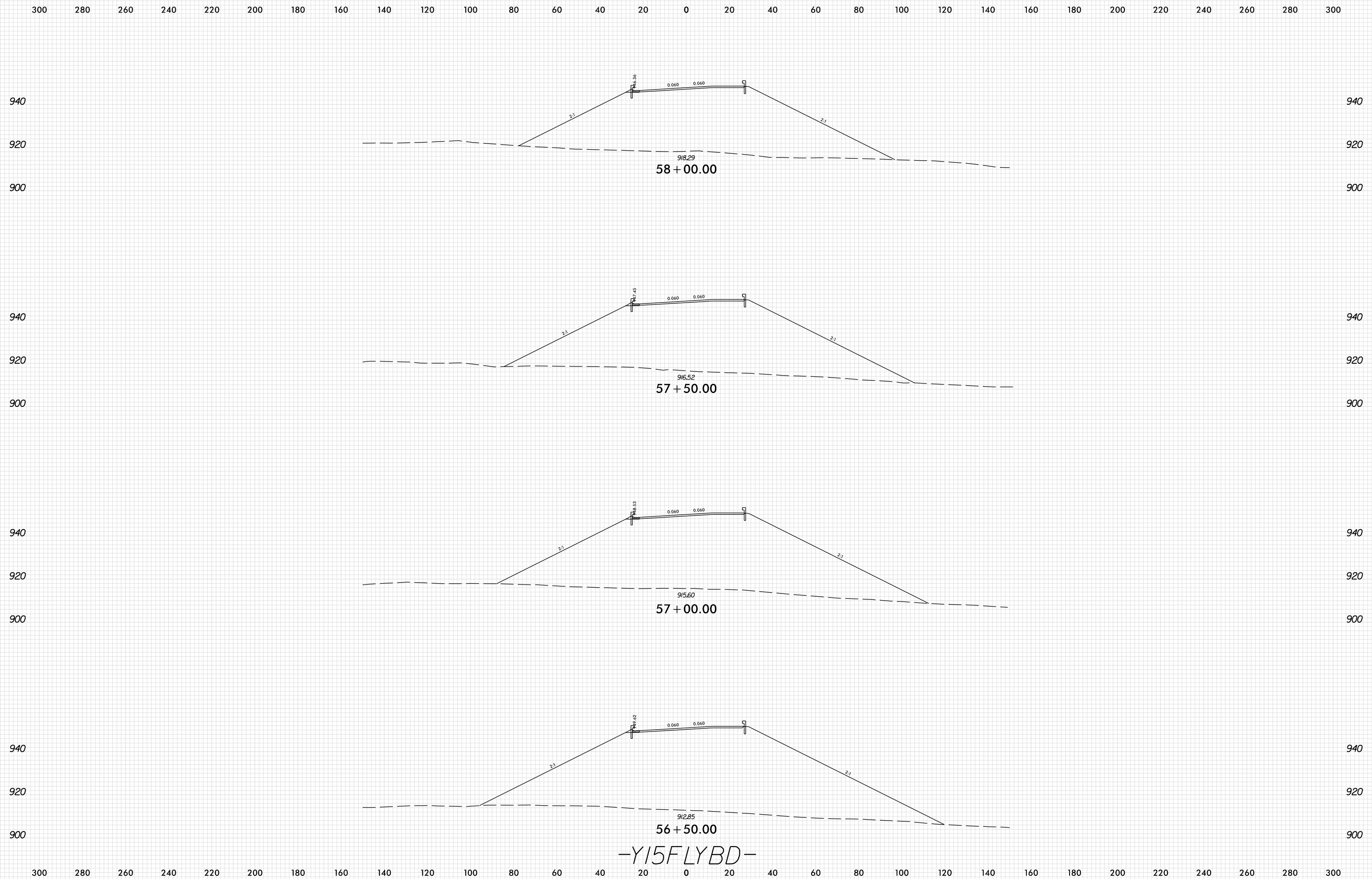

-Y15FLYBD-

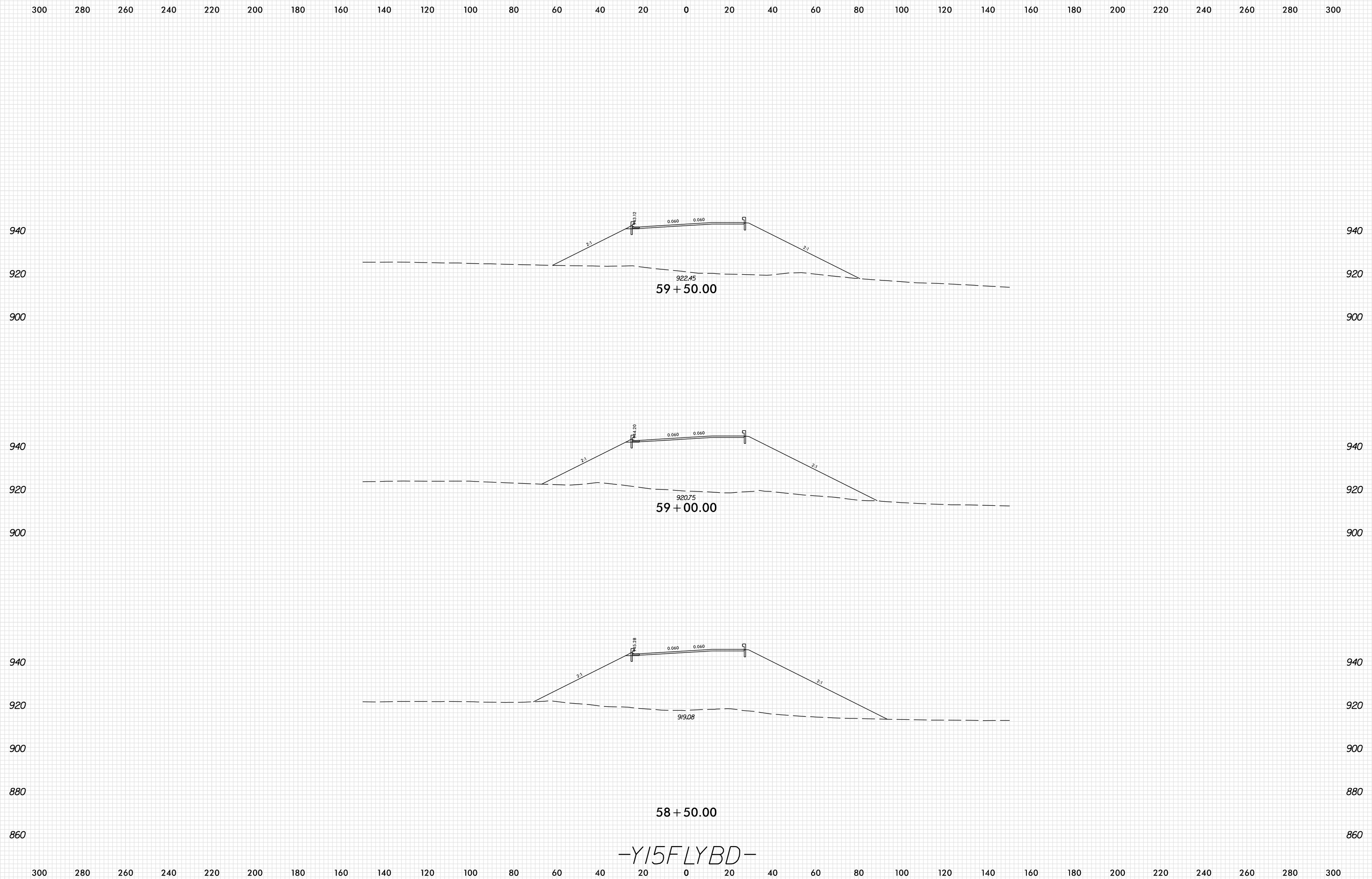

-Y15FLYBD-

8/23/99

0 10 20	PROJ. REFERENCE NO.	SHEET NO.
	U-2579AB	X-464

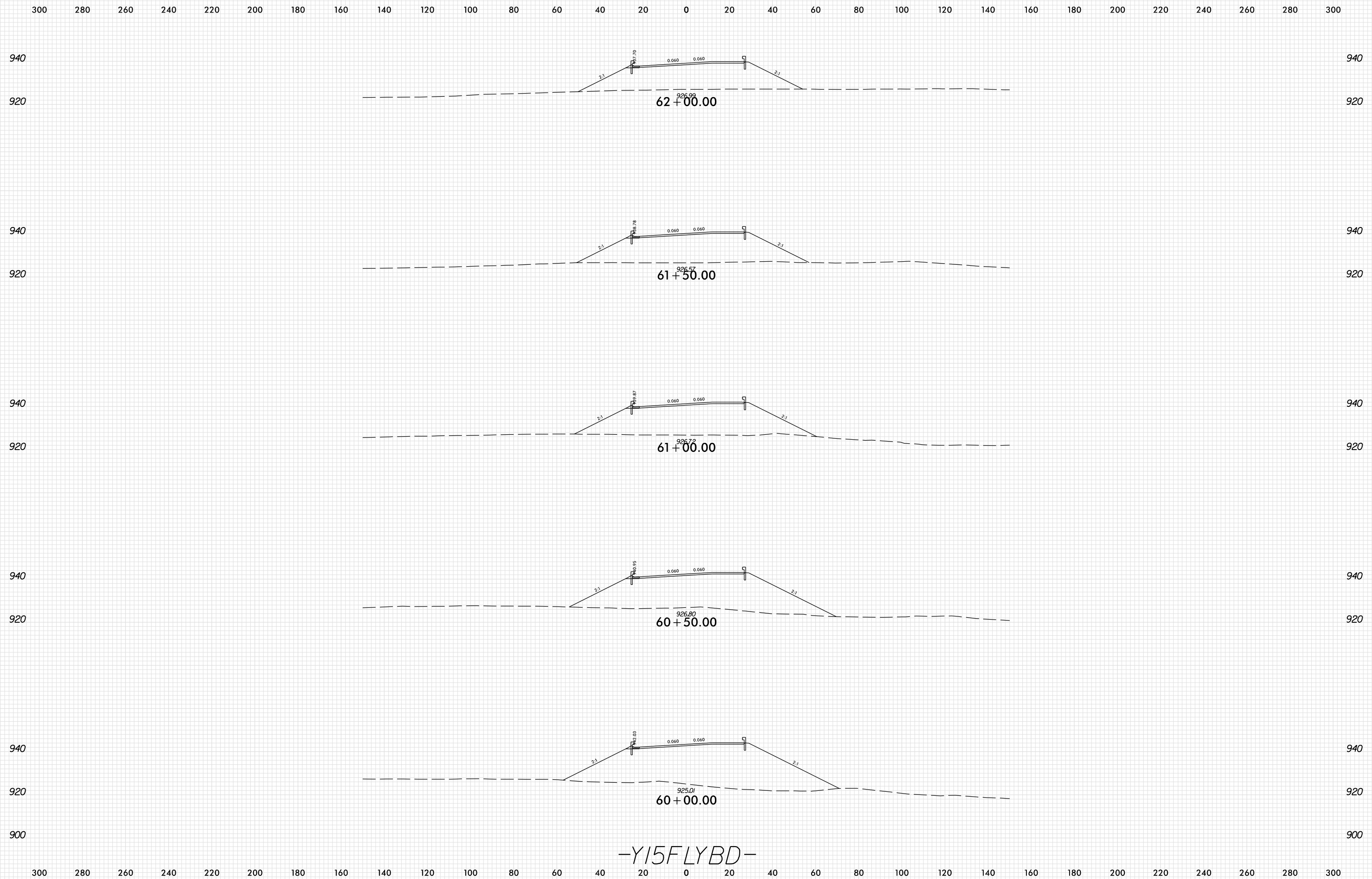

-Y15FLYBD-

PLOT DRIVER: NCD01\_pdf\_color\_eng\_100.plt  
 USER: SPEREIRA  
 DATE: 6/10/2021  
 TIME: 2:27:00 PM  
 FILE: \

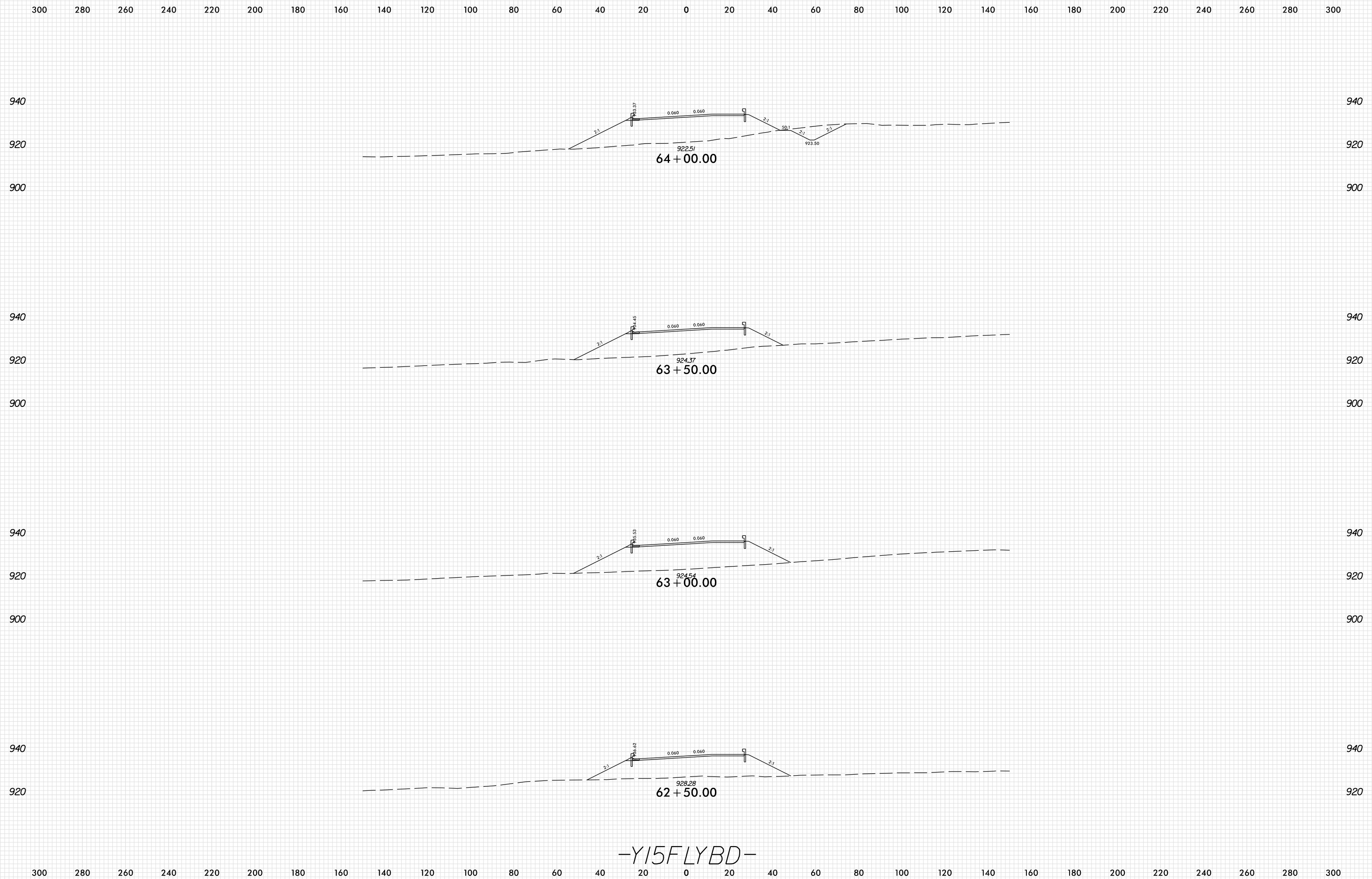

-Y15FLYBD-

8/23/99

0 10 20	PROJ. REFERENCE NO.	SHEET NO.
	U-2579AB	X-466

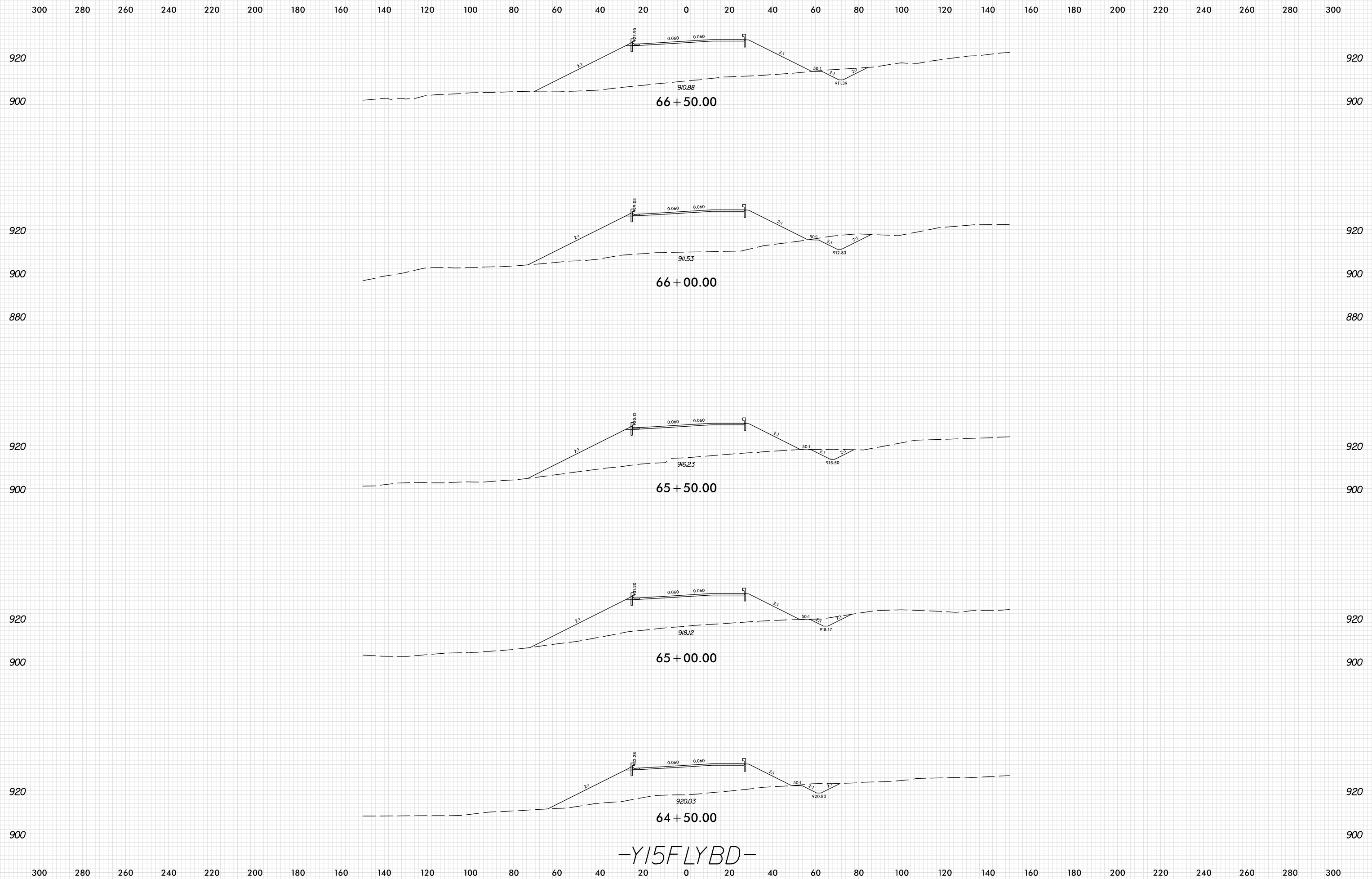

-Y15FLYBD-

PLOT DRIVER: NCD01\_pdf\_color\_eng\_100.plt  
 USER: SPEREIRA  
 DATE: 6/10/2021  
 TIME: 2:27:01 PM  
 FILE: \

8/23/99

0 10 20	PROJ. REFERENCE NO.	SHEET NO.
	U-2579AB	X-467

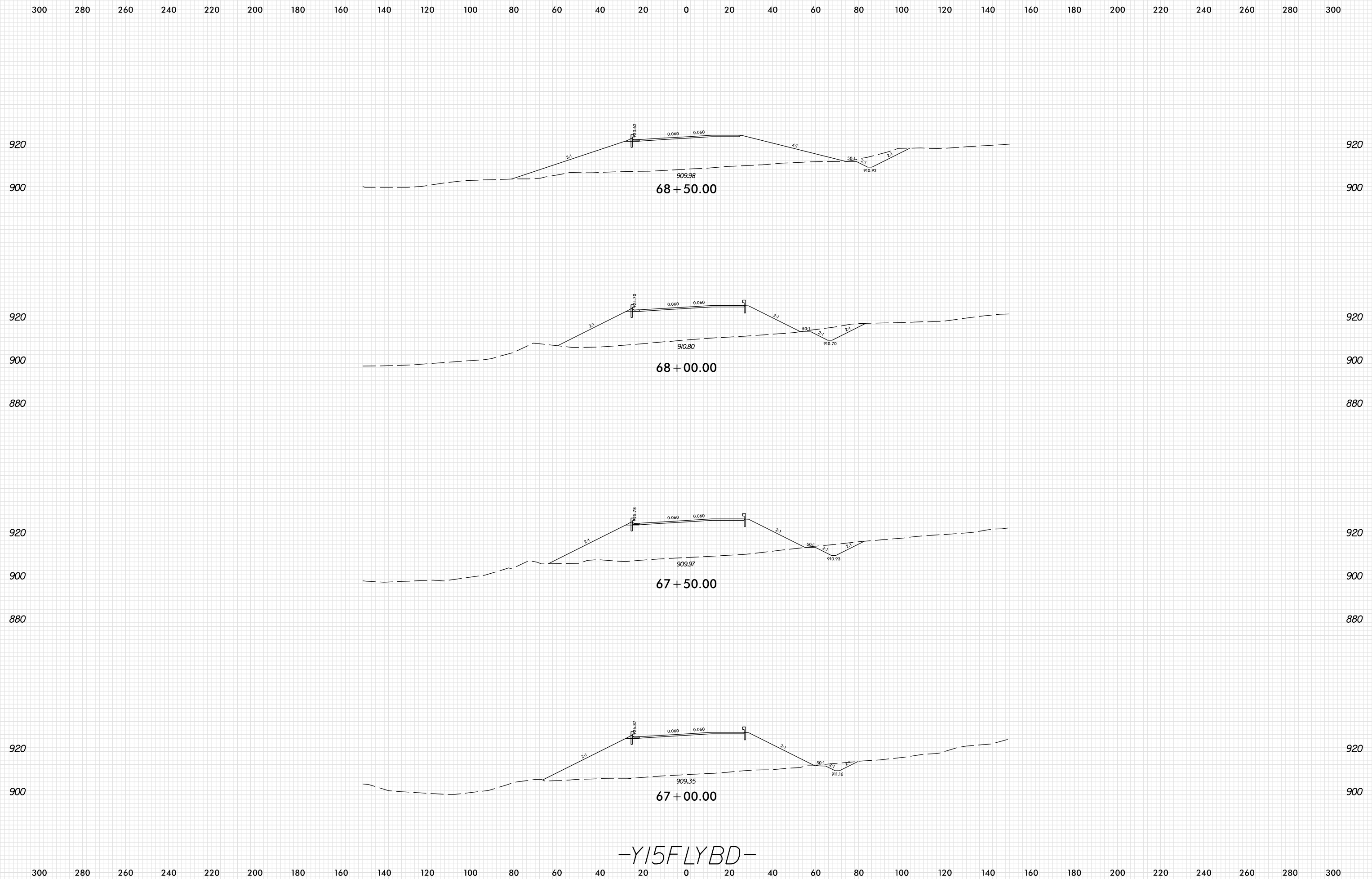

-Y15FLYBD-

PLOT DRIVER: NCD01\_pdf\_color\_eng\_100.plt  
 USER: SPEREIRA  
 DATE: 6/10/2021  
 TIME: 2:27:02 PM  
 FILE: \

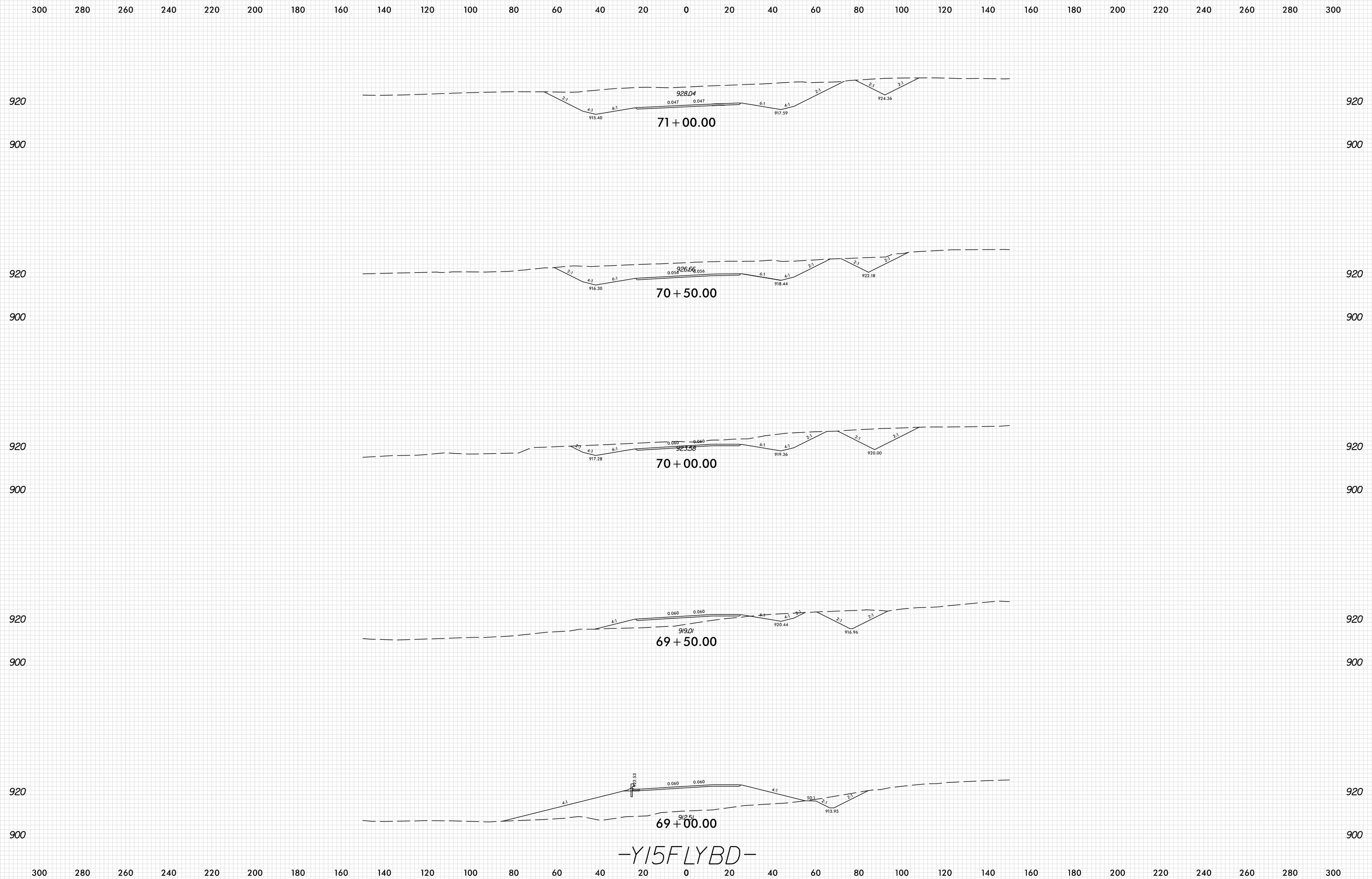

-Y15FLYBD-



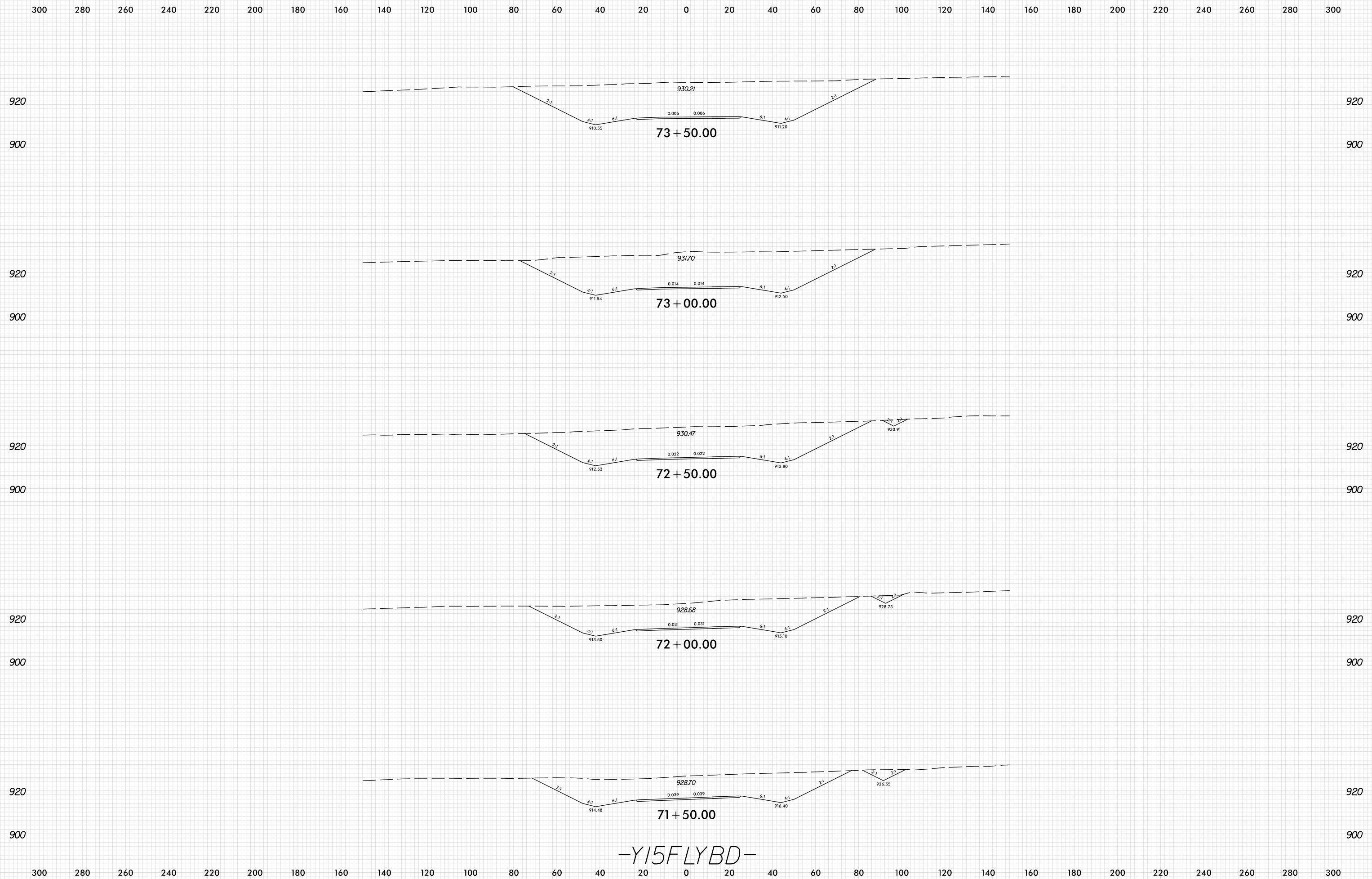

-Y15FLYBD-

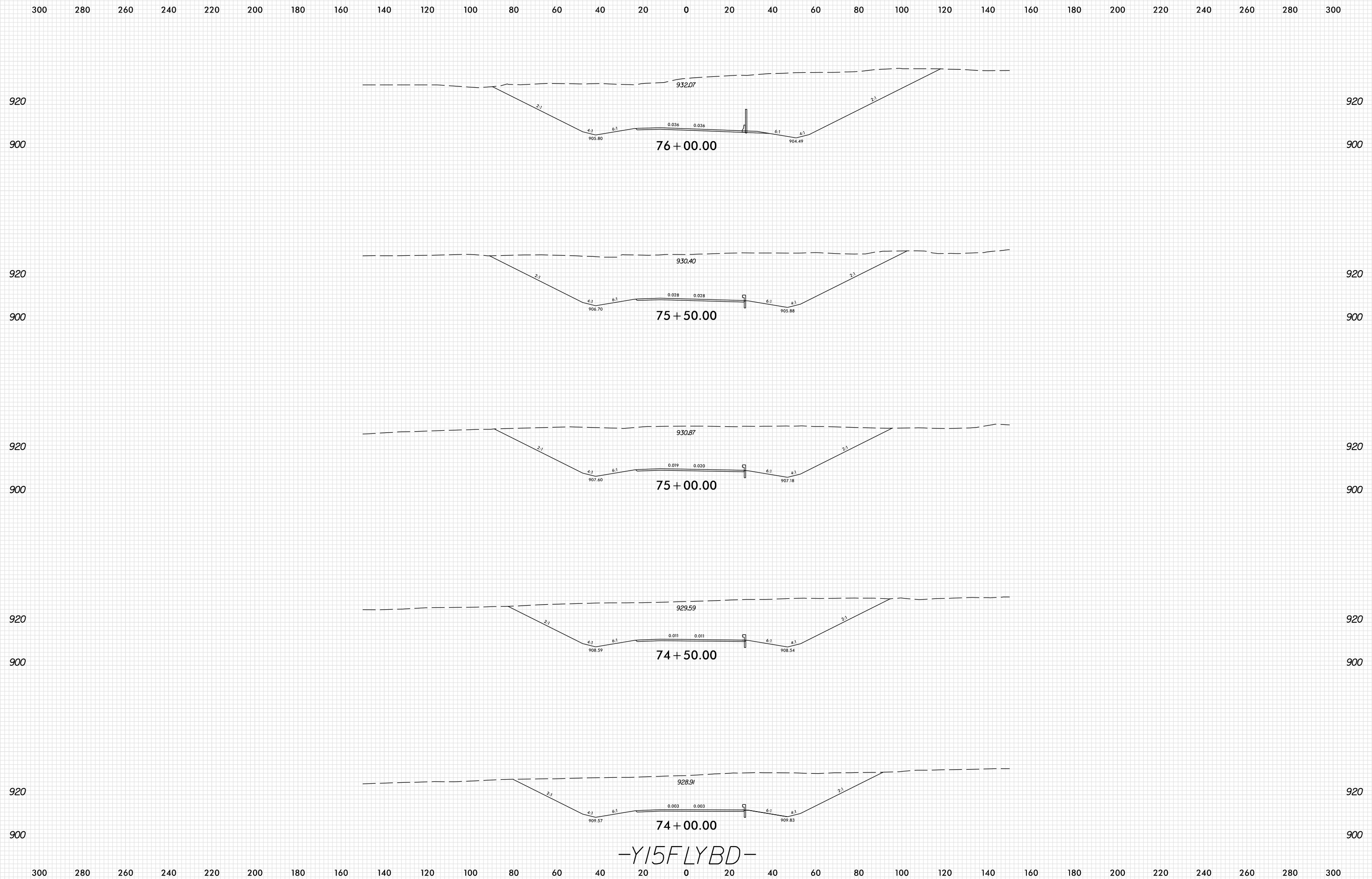

-Y15FLYBD-

8/23/99

0 10 20	PROJ. REFERENCE NO.	SHEET NO.
	U-2579AB	X-471

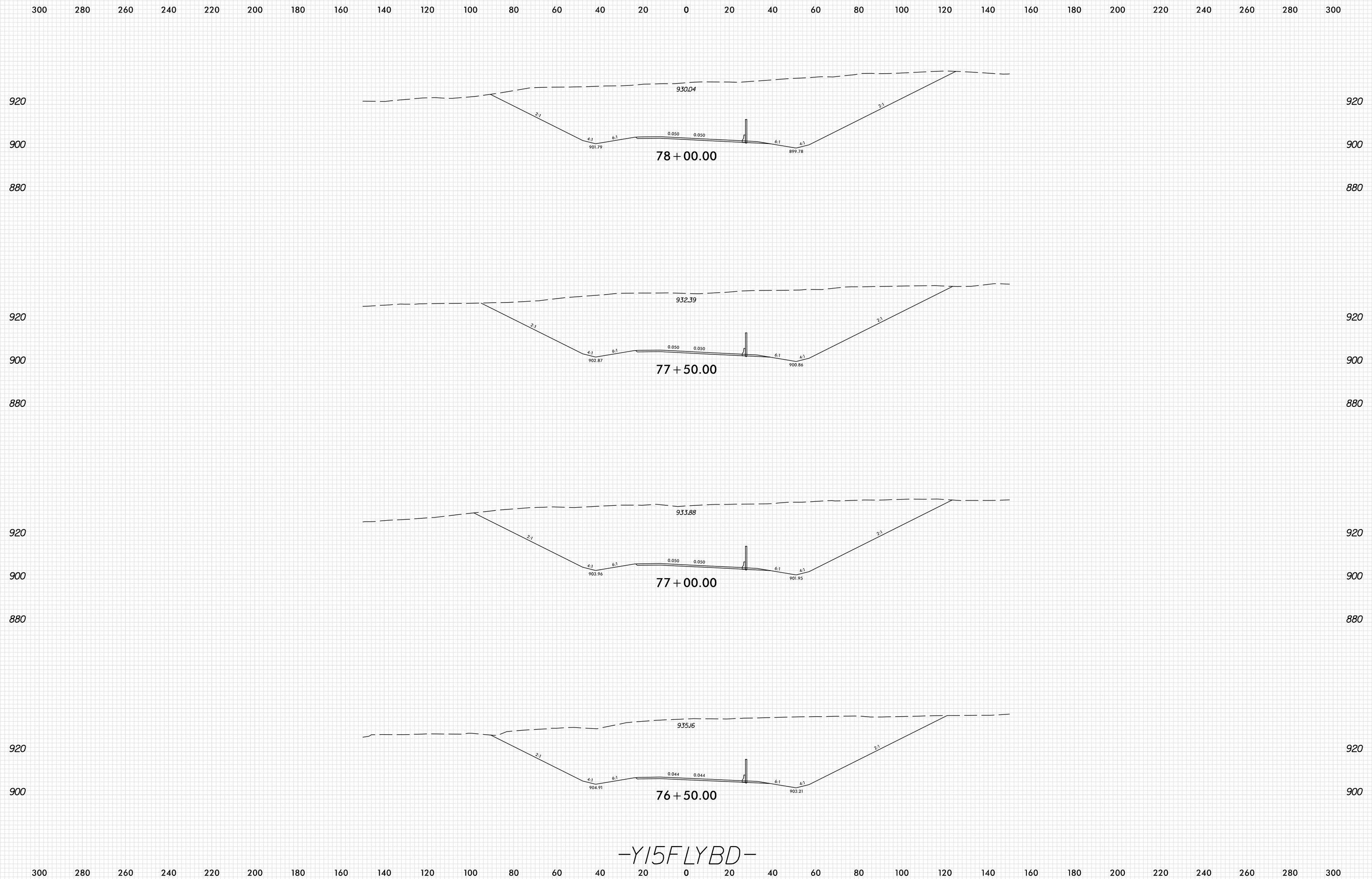

-Y15FLYBD-

PLOT DRIVER: NCDOT\_pdf\_color\_eng\_100.plt  
 USER: SPEREIRA  
 DATE: 6/10/2021  
 TIME: 2:27:04 PM  
 FILE: \

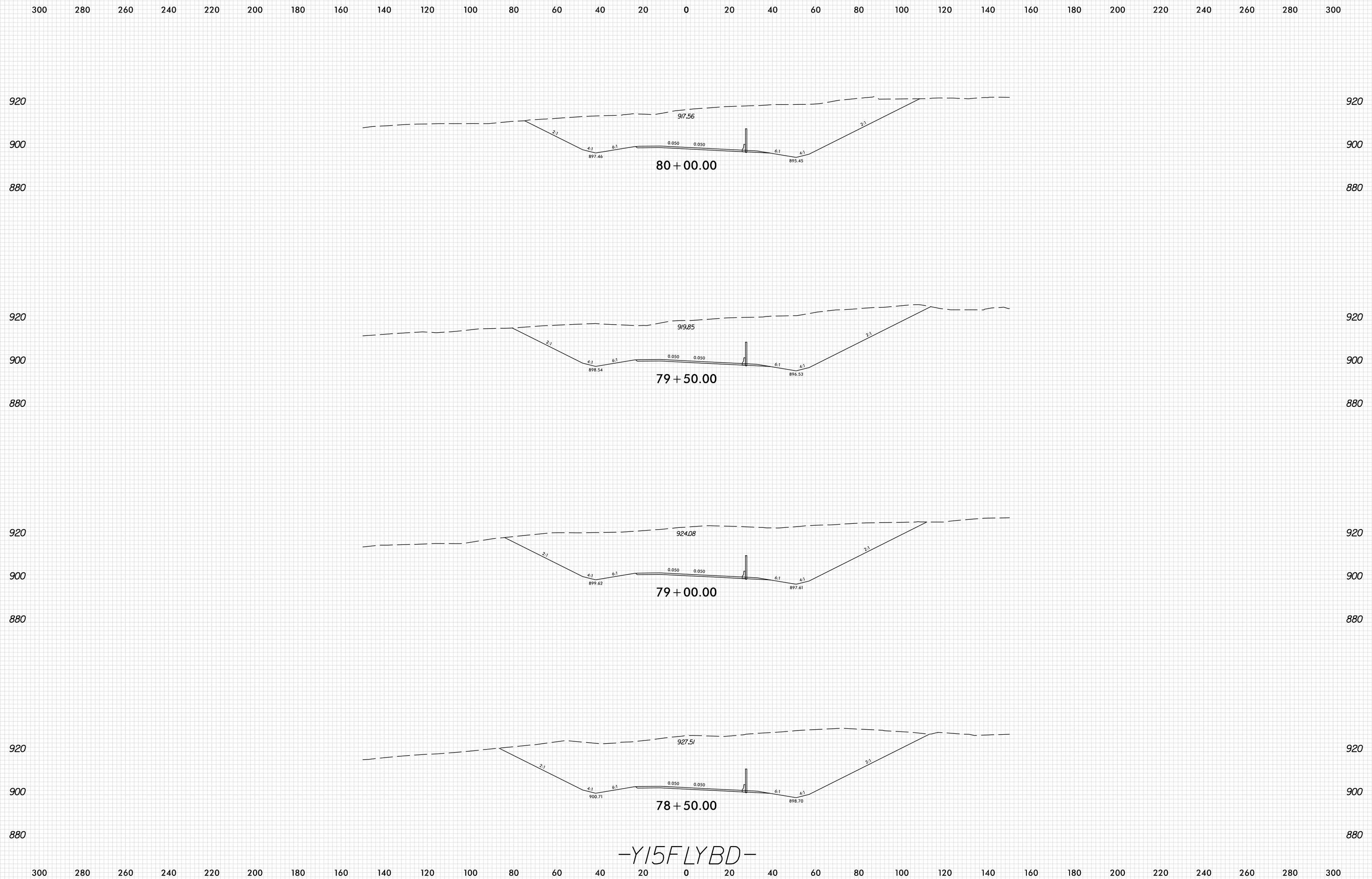

-Y15FLYBD-

8/23/99

0 10 20	PROJ. REFERENCE NO.	SHEET NO.
	U-2579AB	X-473

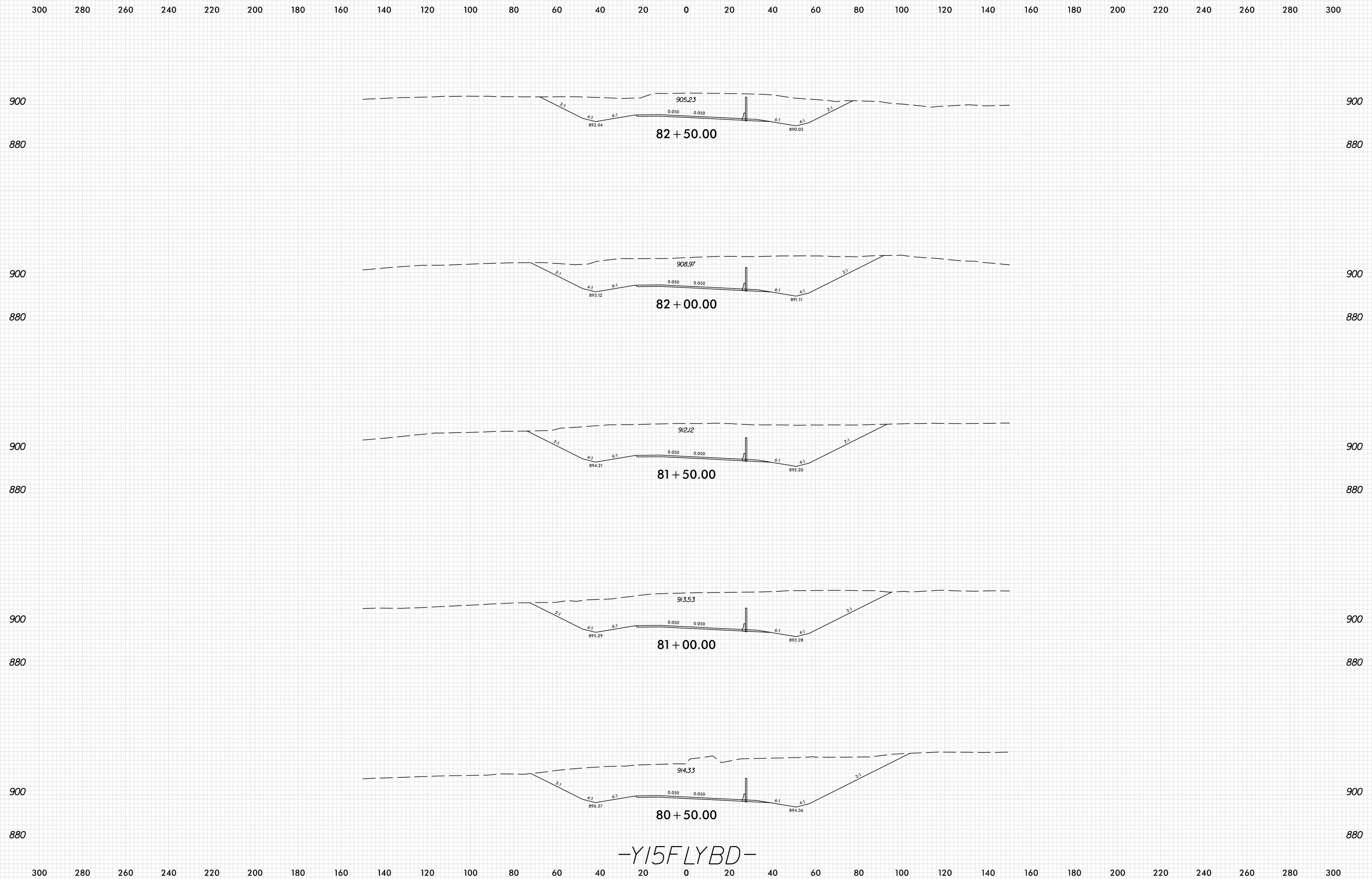

-Y15FLYBD-

PLOT DRIVER: NCDOT\_pdf\_color\_eng\_100.plt  
 USER: SPEREIRA  
 DATE: 6/10/2021  
 TIME: 2:27:06 PM  
 FILE: \

8/23/99

0 10 20	PROJ. REFERENCE NO.	SHEET NO.
	U-2579AB	X-474

300 280 260 240 220 200 180 160 140 120 100 80 60 40 20 0 20 40 60 80 100 120 140 160 180 200 220 240 260 280 300

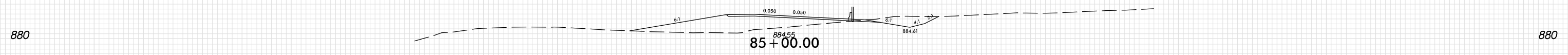

880 860 880 860

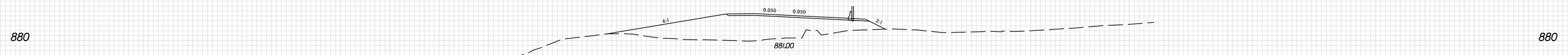

880 860 880 860

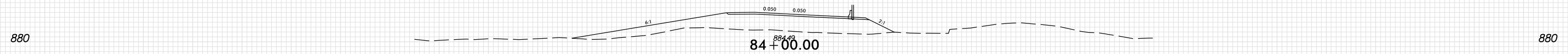

880 860 880 860

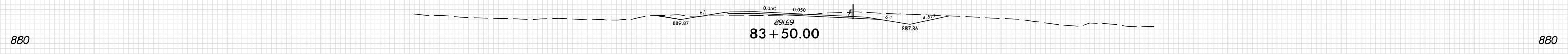

880 860 880 860

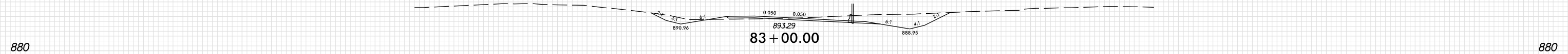

880 860 880 860

-Y15FLYBD-

PLOT DRIVER: NCDOT\_pdf\_color\_eng\_100.plt  
 USER: SPEREIRA  
 DATE: 6/10/2021  
 TIME: 2:27:06 PM  
 FILE: \

300 280 260 240 220 200 180 160 140 120 100 80 60 40 20 0 20 40 60 80 100 120 140 160 180 200 220 240 260 280 300

8/23/99

0 10 20	PROJ. REFERENCE NO.	SHEET NO.
	U-2579AB	X-475

300 280 260 240 220 200 180 160 140 120 100 80 60 40 20 0 20 40 60 80 100 120 140 160 180 200 220 240 260 280 300

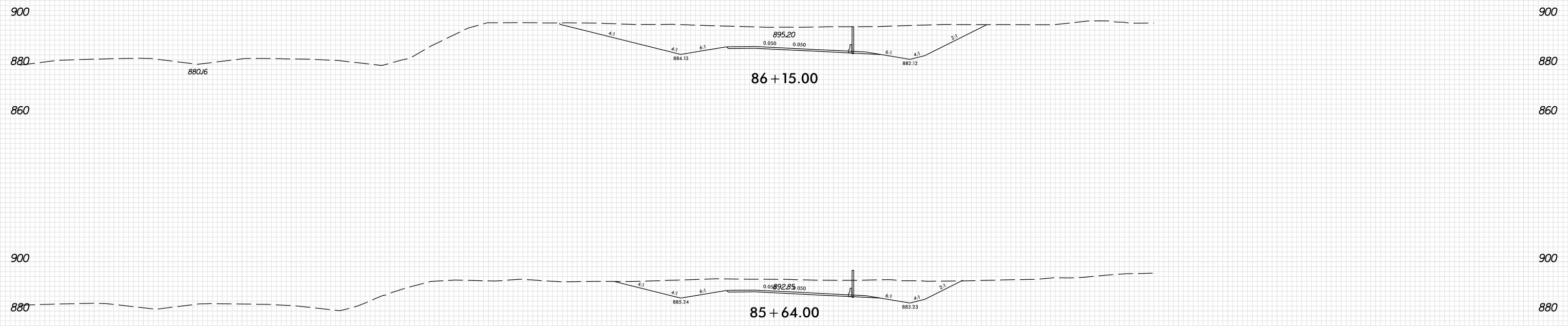

-Y15FLYBD-

PLOT DRIVER: NCDOT\_pdf\_color\_eng\_100.plt  
 USER: SPEREIRA  
 FILE: \

DATE: 6/10/2021  
 TIME: 2:27:07 PM

PENTABLE: xpl\_en\_v8.tbl

8/23/99

0 10 20	PROJ. REFERENCE NO.	SHEET NO.
	U-2579AB	X-476

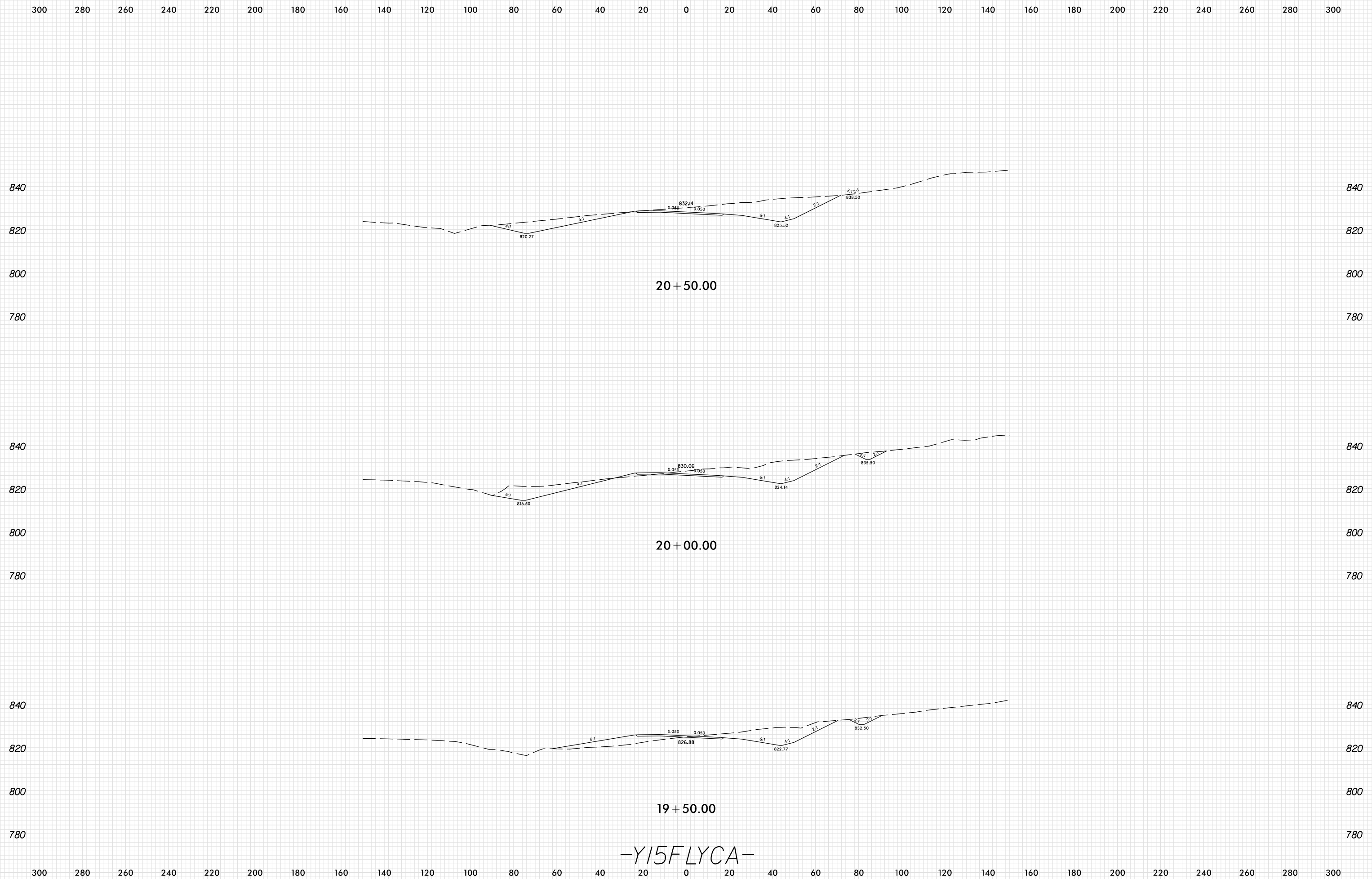

-Y15FLYCA-

PLOT DRIVER: NCD01\_pdf\_color\_eng\_100.plt  
 USER: SPEREIRA  
 DATE: 6/10/2021  
 TIME: 2:27:33 PM  
 FILE: \



8/23/99

0 10 20	PROJ. REFERENCE NO.	SHEET NO.
	U-2579AB	X-477

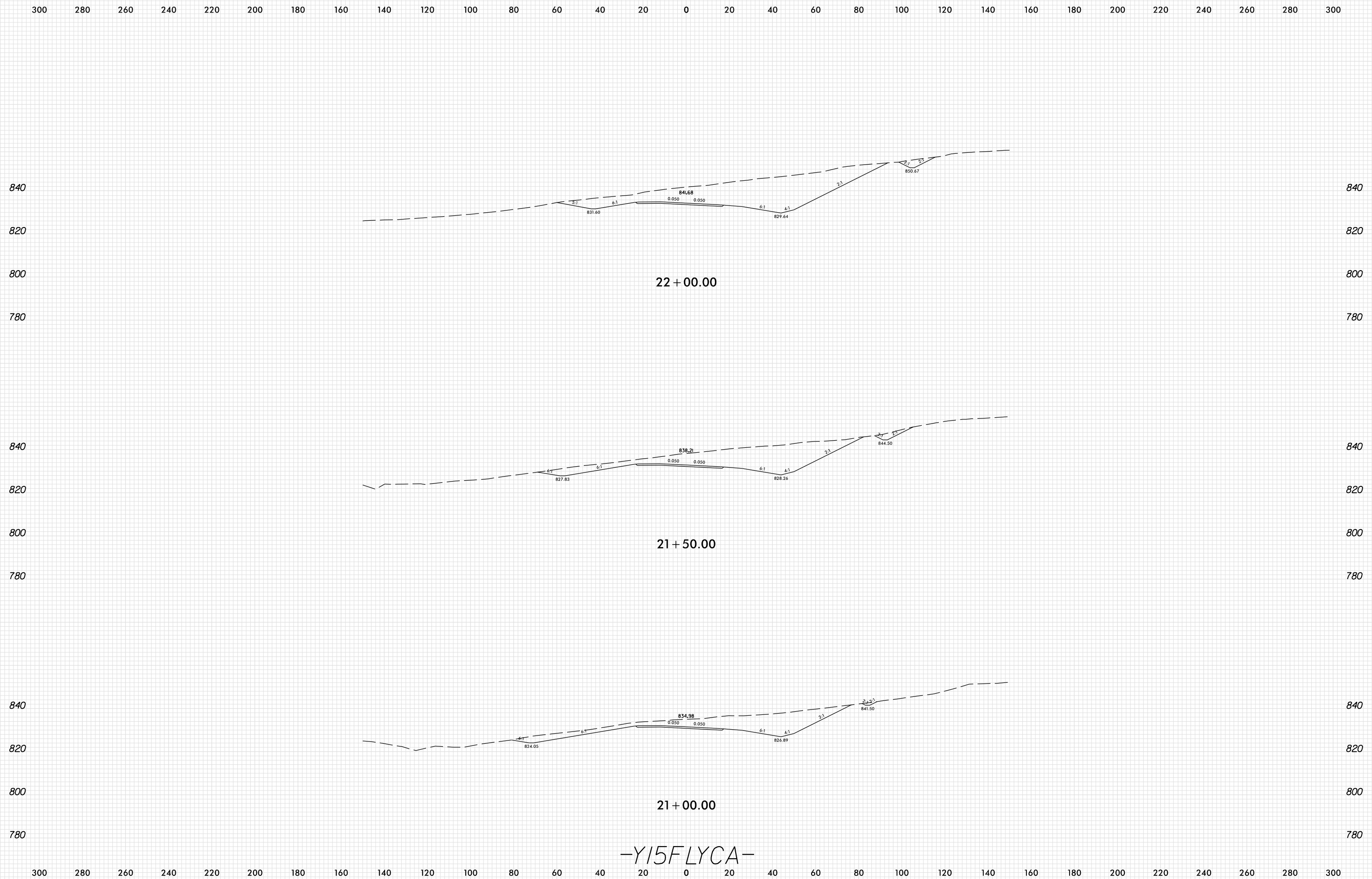

-Y15FLYCA-

PLOT DRIVER: NCD01\_pdf\_color\_eng\_100.plt  
 USER: SPEREIRA  
 DATE: 6/10/2021  
 TIME: 2:27:34 PM  
 FILE: \

8/23/99

0 10 20	PROJ. REFERENCE NO.	SHEET NO.
	U-2579AB	X-478

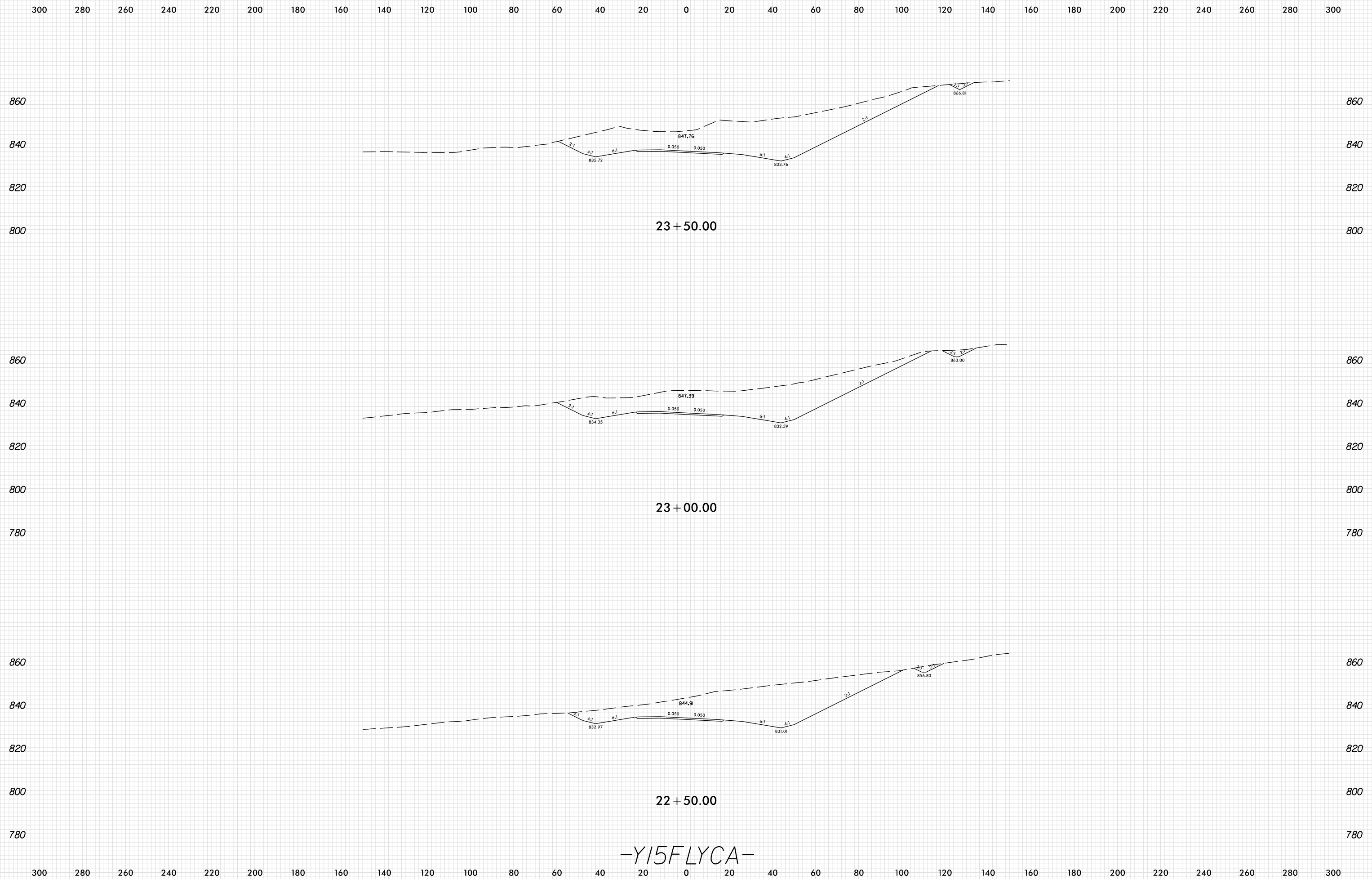

-Y15FLYCA-

PLOT DRIVER: NCDOT\_pdf\_color\_eng\_100.plt  
 USER: SPEREIRA  
 DATE: 6/10/2021  
 TIME: 2:27:34 PM  
 FILE: \

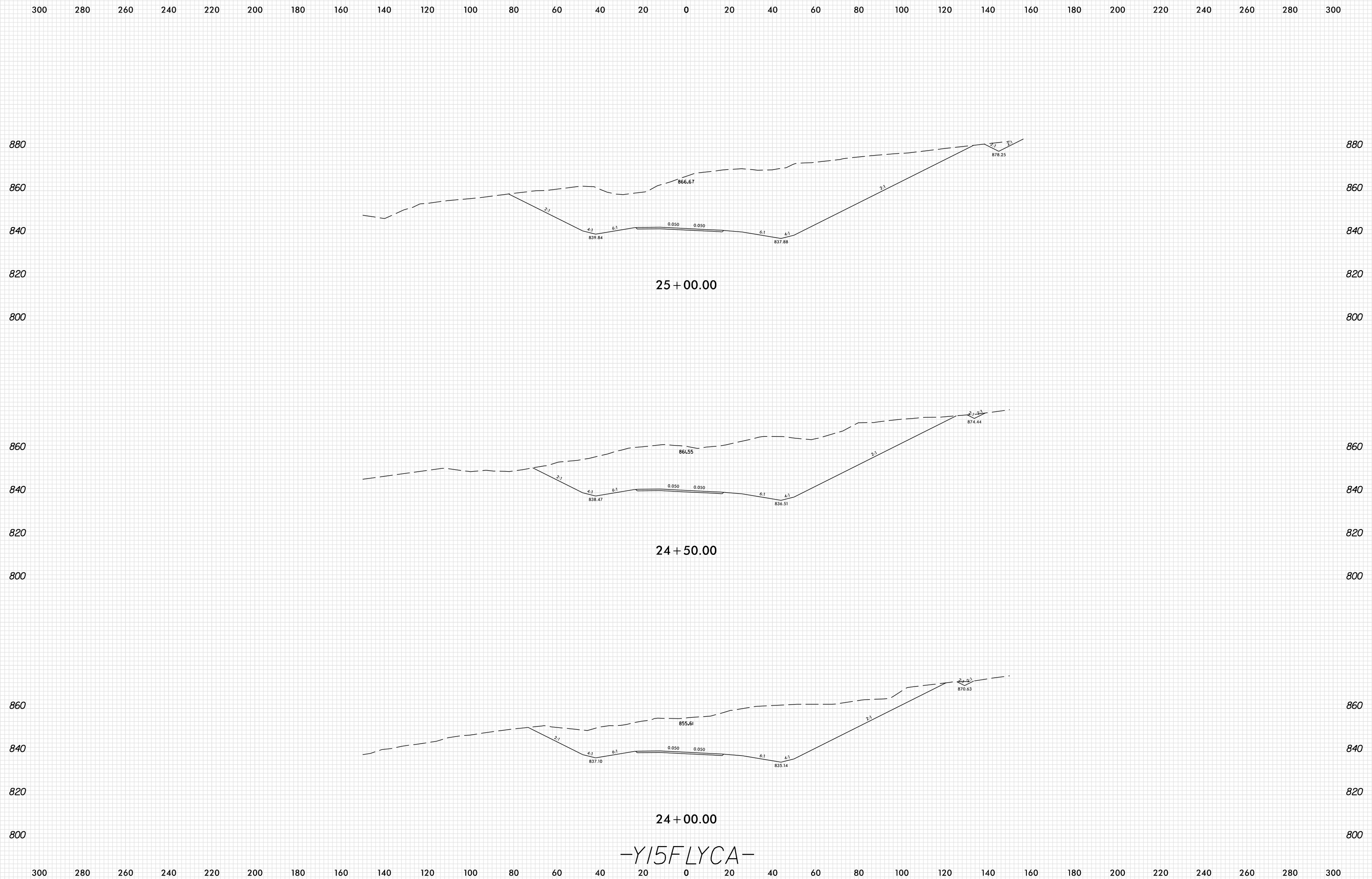

-Y15FLYCA-

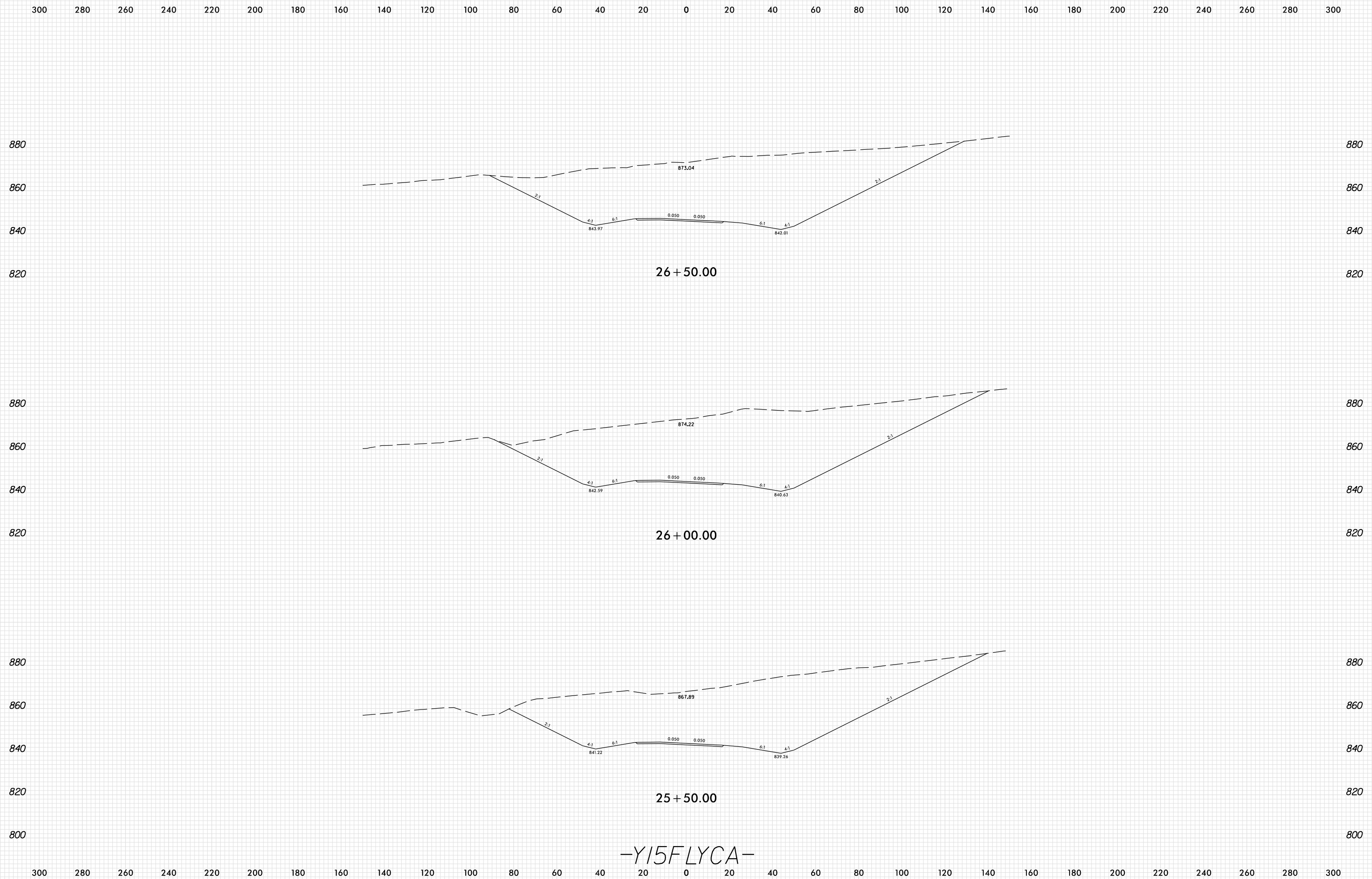

-Y15FLYCA-

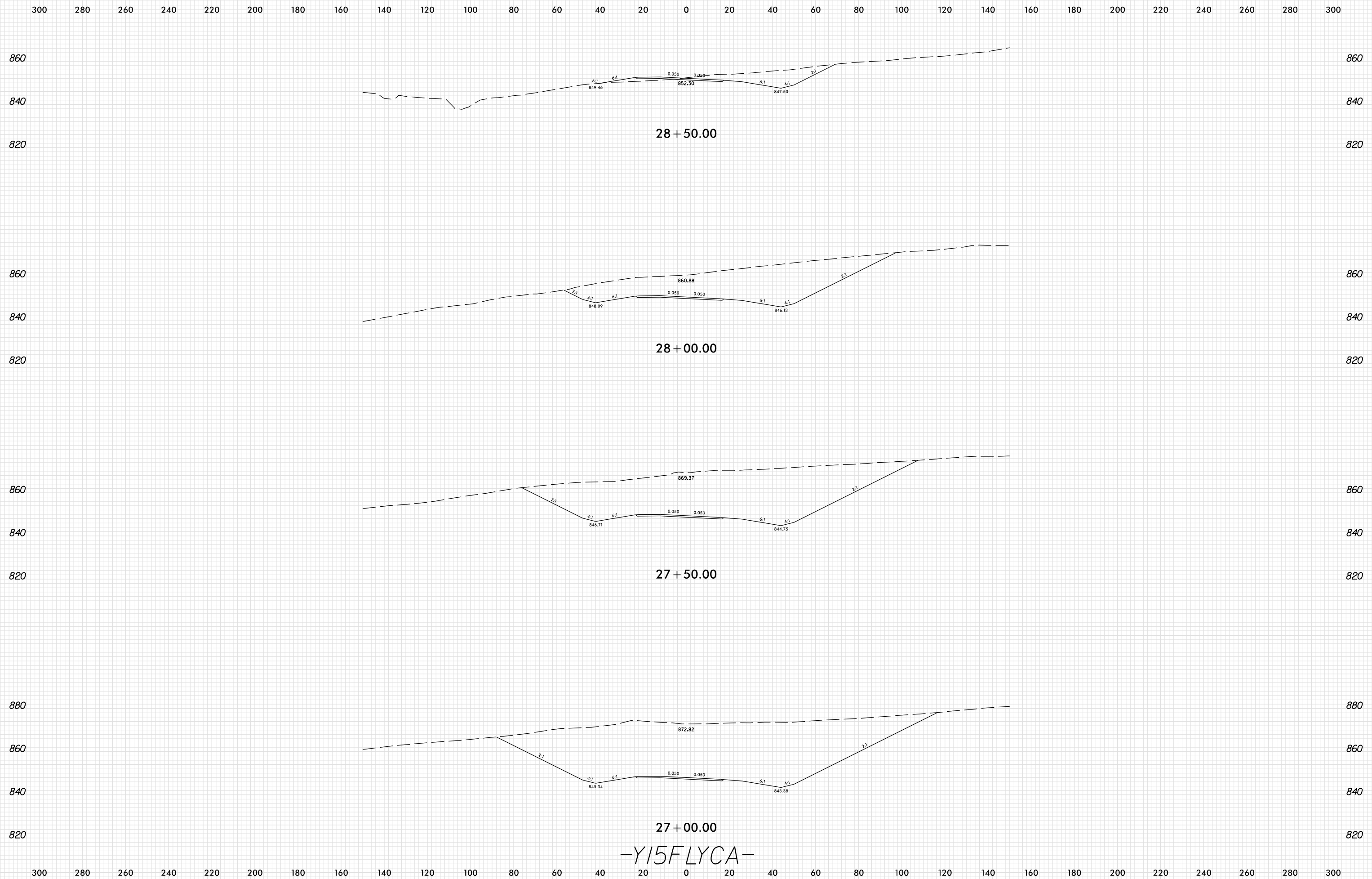

-Y15FLYCA-

8/23/99

0 10 20	PROJ. REFERENCE NO.	SHEET NO.
	U-2579AB	X-482

300 280 260 240 220 200 180 160 140 120 100 80 60 40 20 0 20 40 60 80 100 120 140 160 180 200 220 240 260 280 300

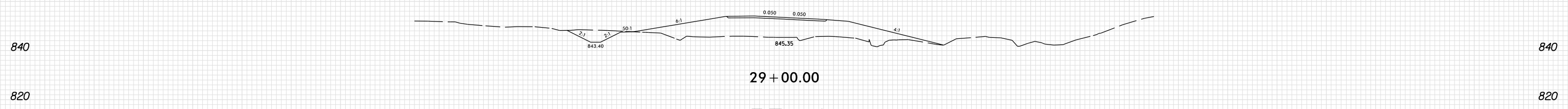
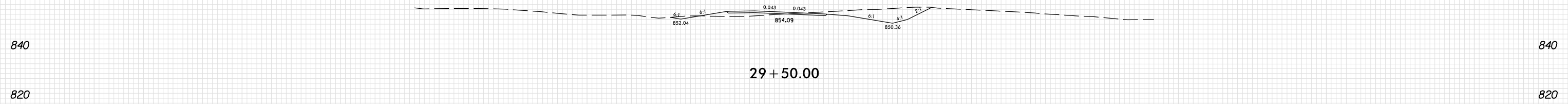
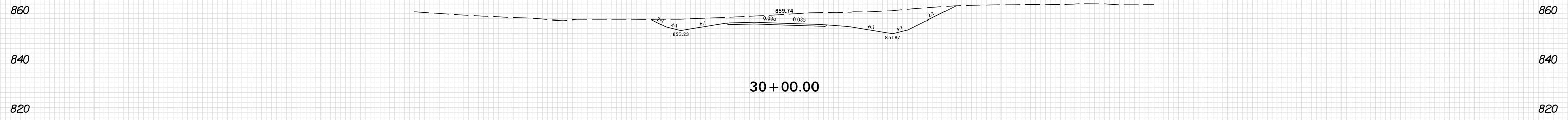
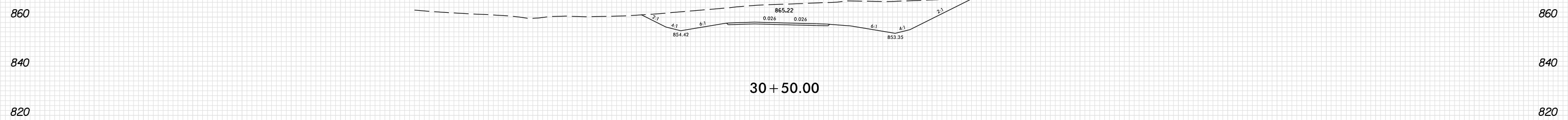

-Y15FLYCA-

300 280 260 240 220 200 180 160 140 120 100 80 60 40 20 0 20 40 60 80 100 120 140 160 180 200 220 240 260 280 300

PLOT DRIVER: NCD01\_pdf\_color\_eng\_100.plt  
 USER: SPEREIRA  
 DATE: 6/10/2021  
 TIME: 2:27:37 PM  
 FILE: \

8/23/99

0 10 20	PROJ. REFERENCE NO.	SHEET NO.
	U-2579AB	X-483

300 280 260 240 220 200 180 160 140 120 100 80 60 40 20 0 20 40 60 80 100 120 140 160 180 200 220 240 260 280 300

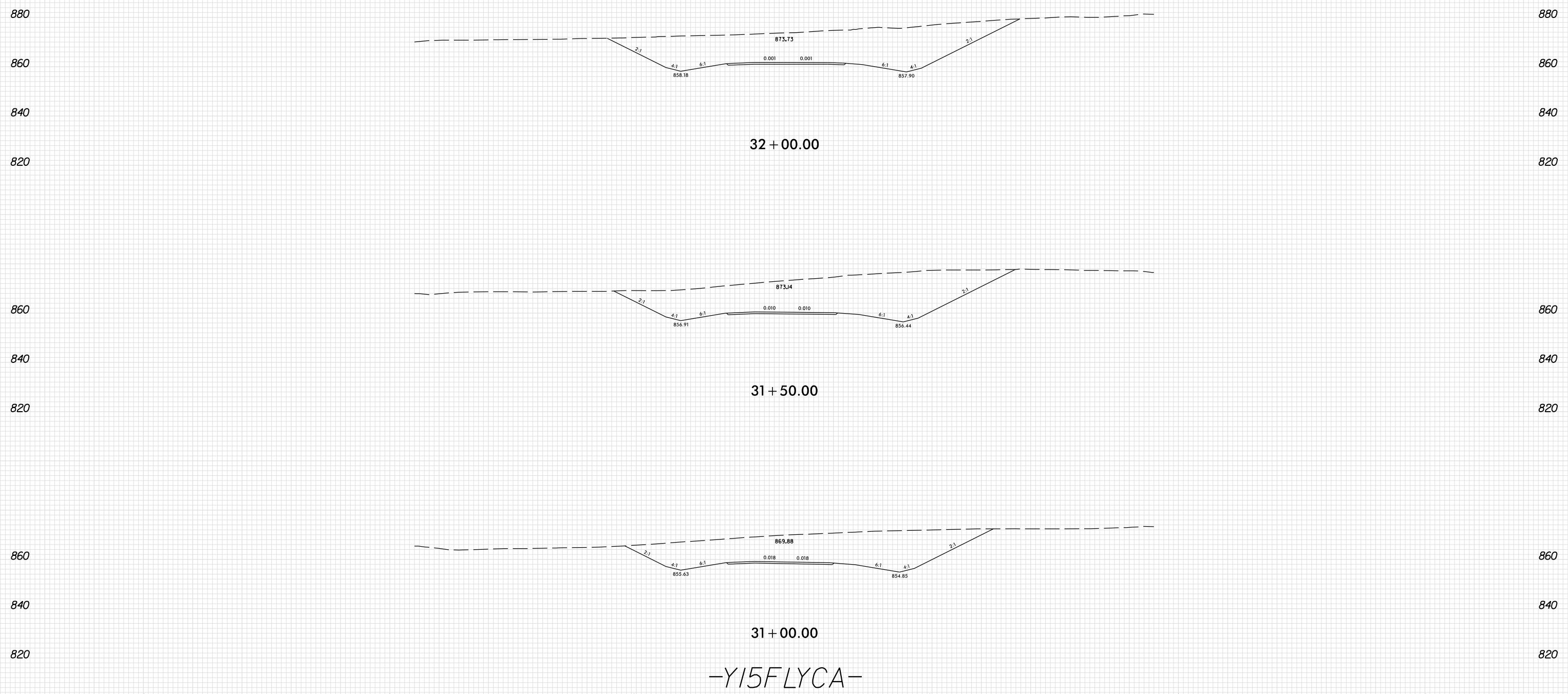

-Y15FLYCA-

PLOT DRIVER: NCD01\_pdf\_color\_eng\_100.plt  
 USER: SPEREIRA  
 DATE: 6/10/2021  
 TIME: 2:27:38 PM  
 FILE: \

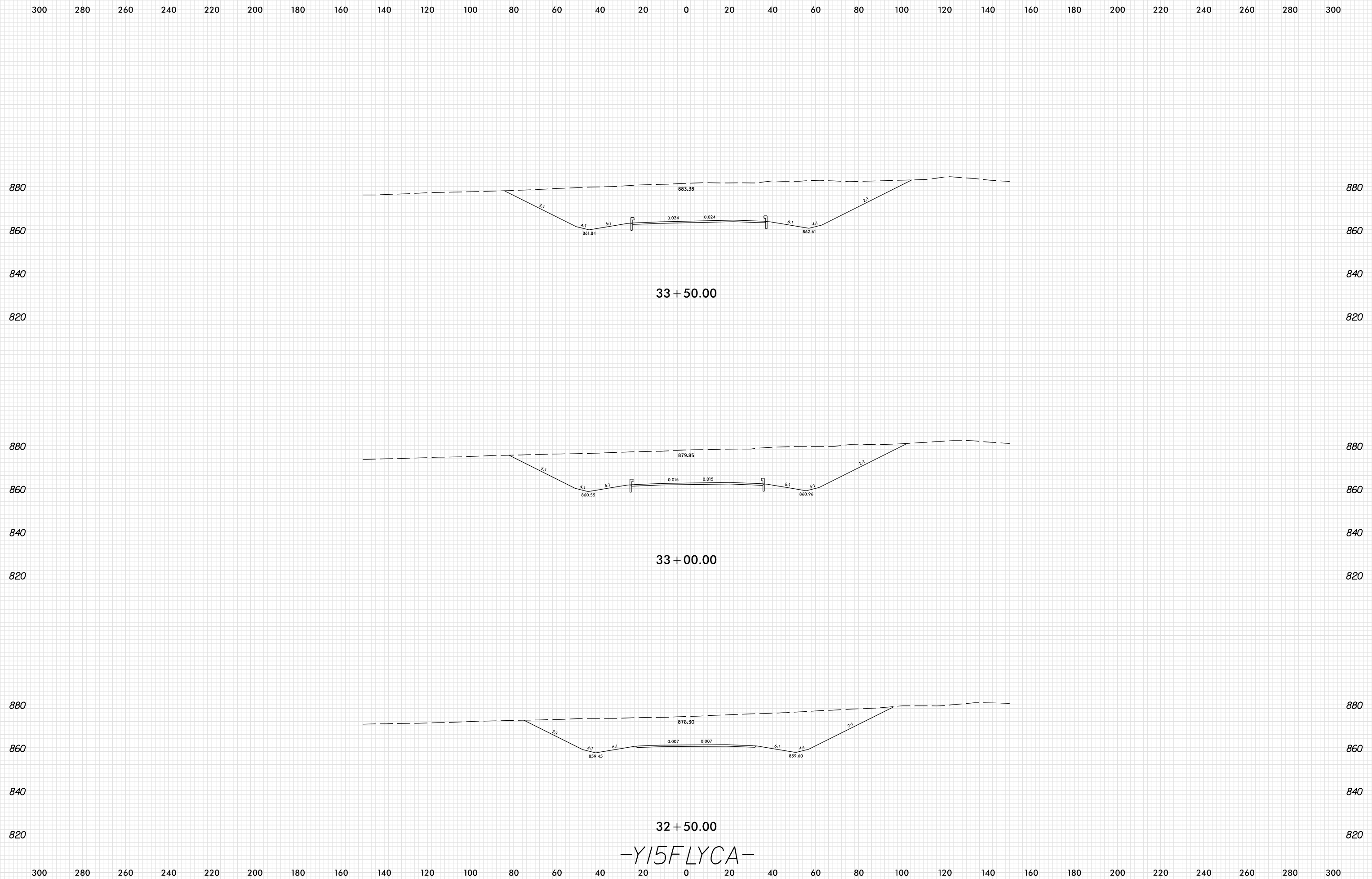

-Y15FLYCA-



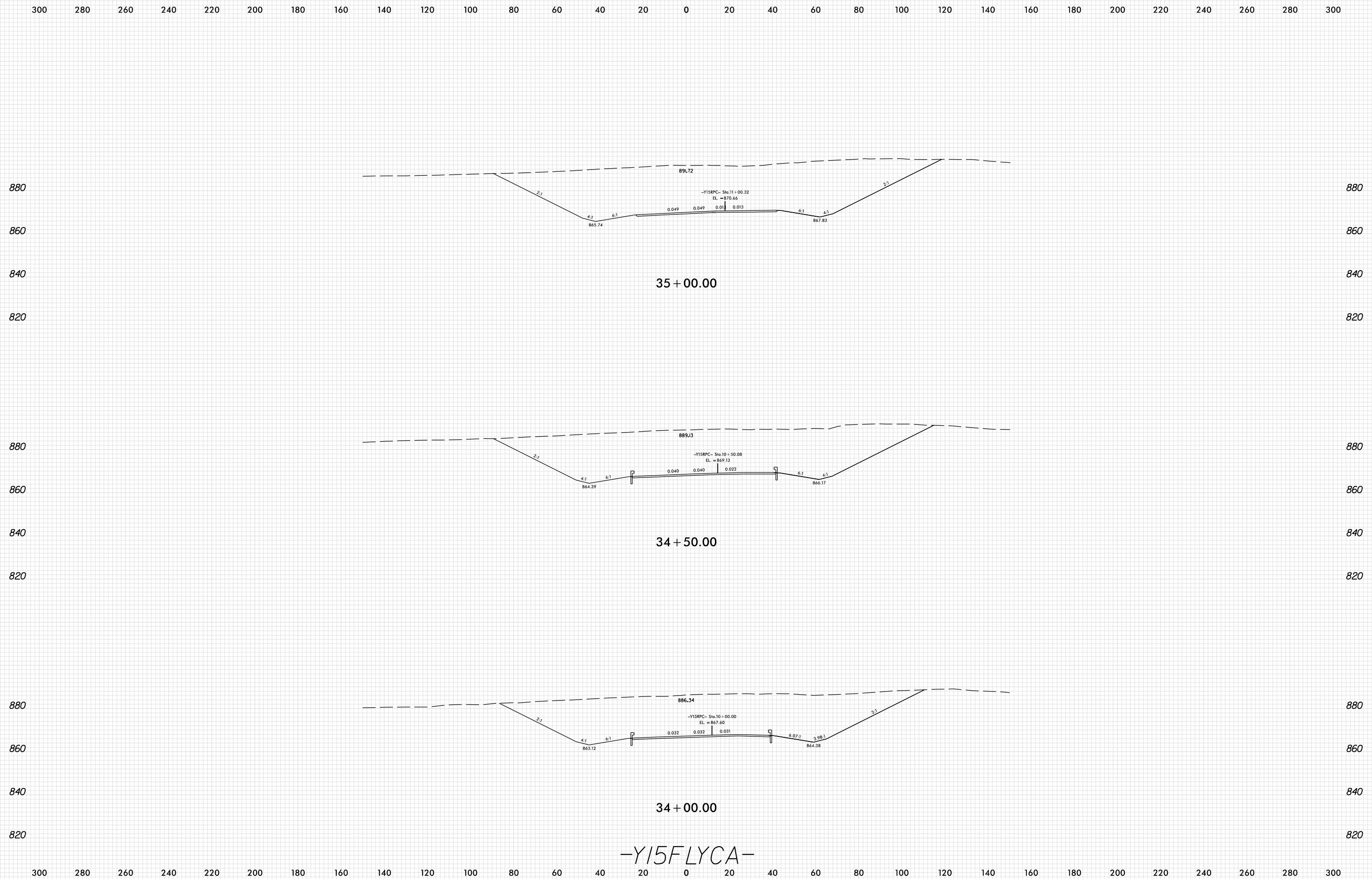

-Y15FLYCA-

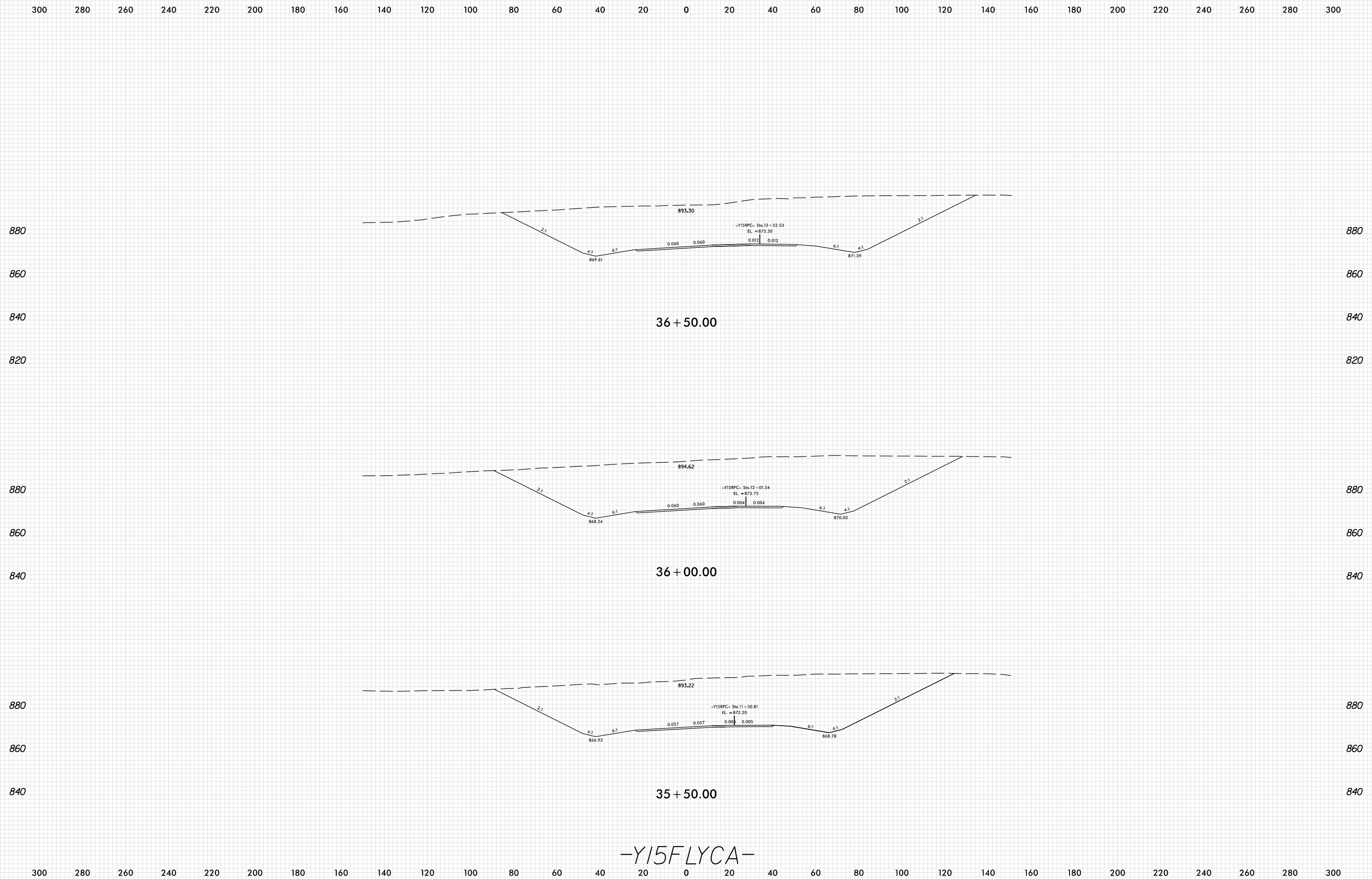

-Y15FLYCA-

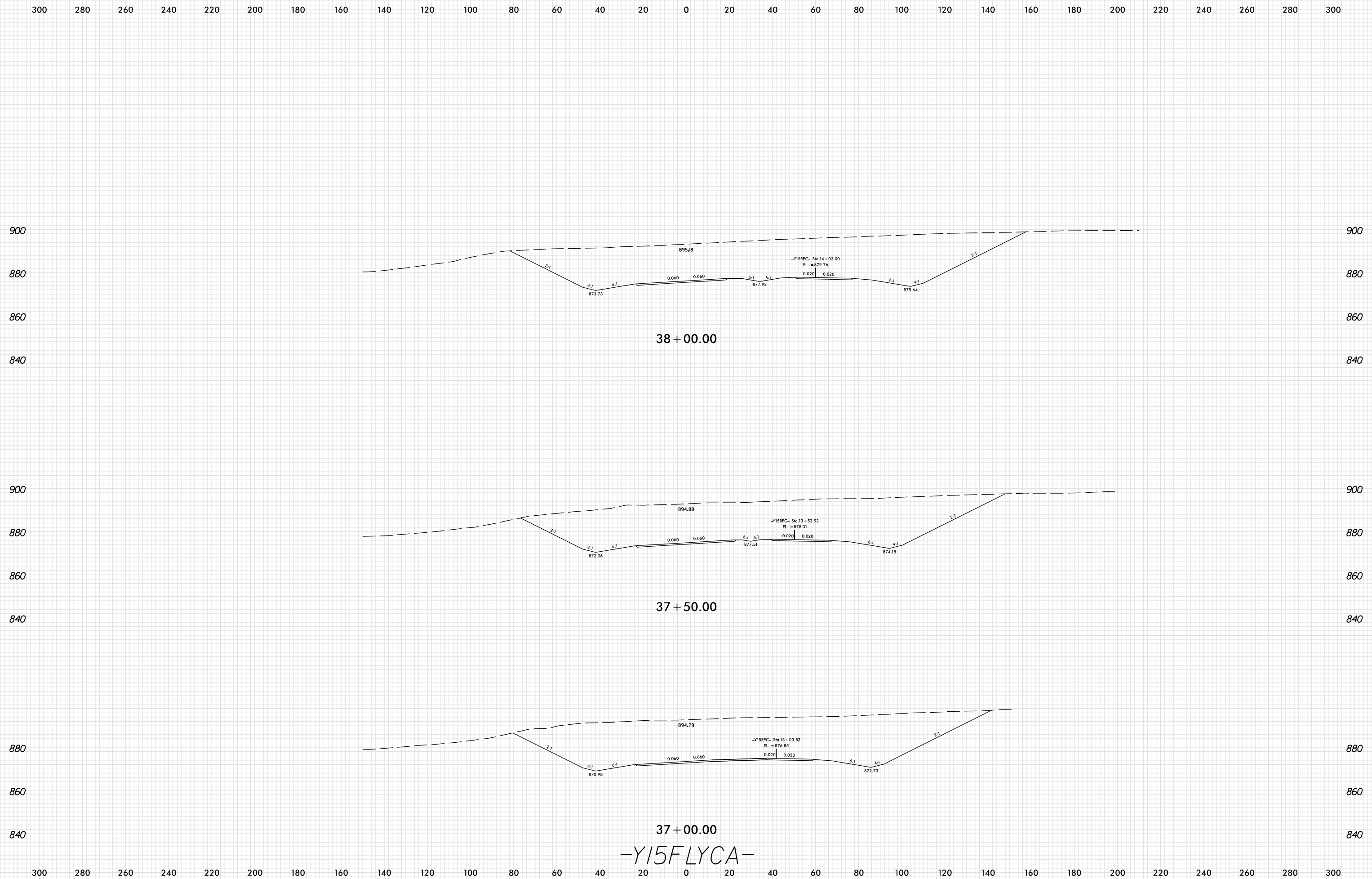

-Y15FLYCA-

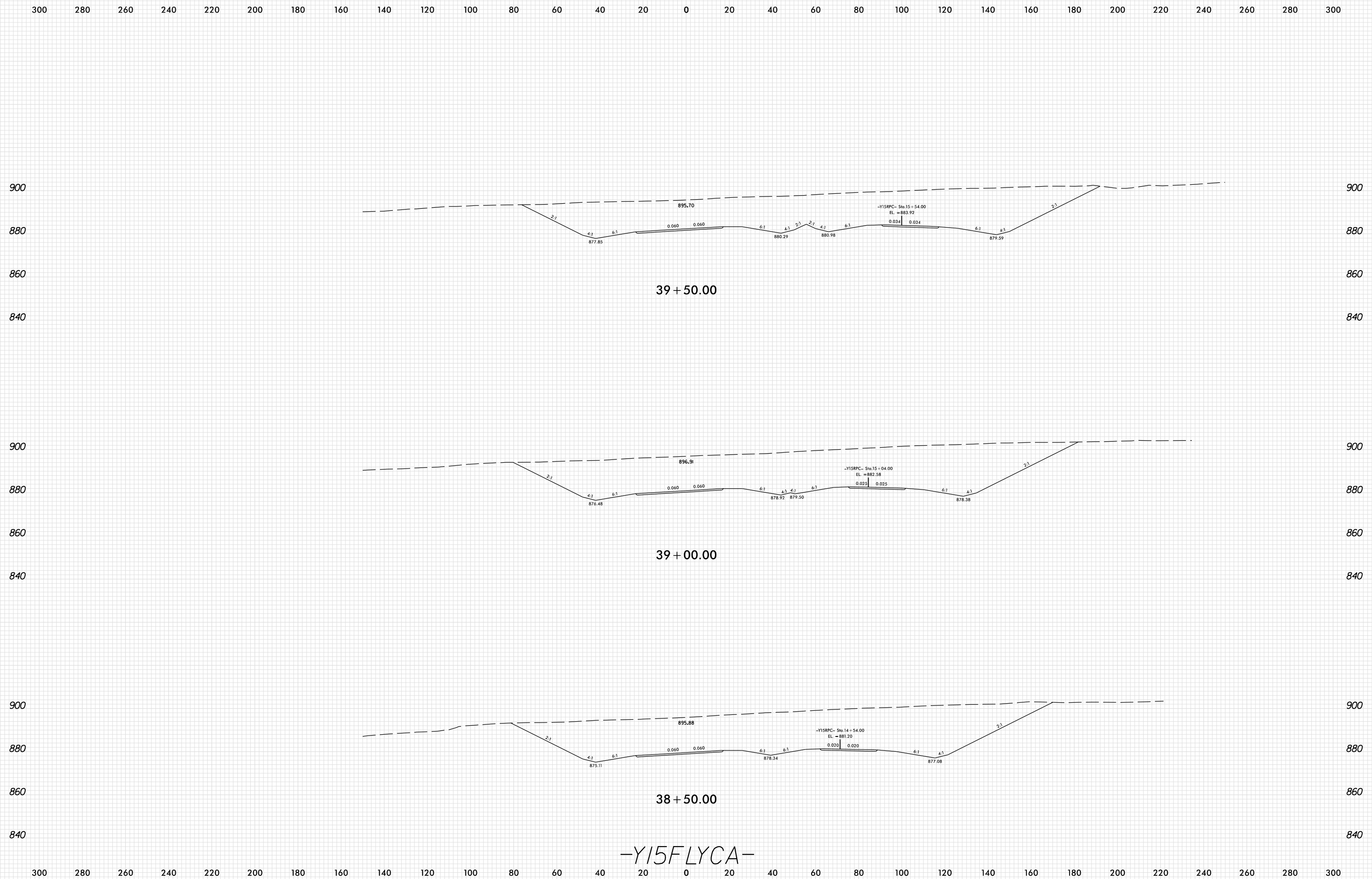

-Y15FLYCA-

8/23/99

0 10 20	PROJ. REFERENCE NO.	SHEET NO.
	U-2579AB	X-489

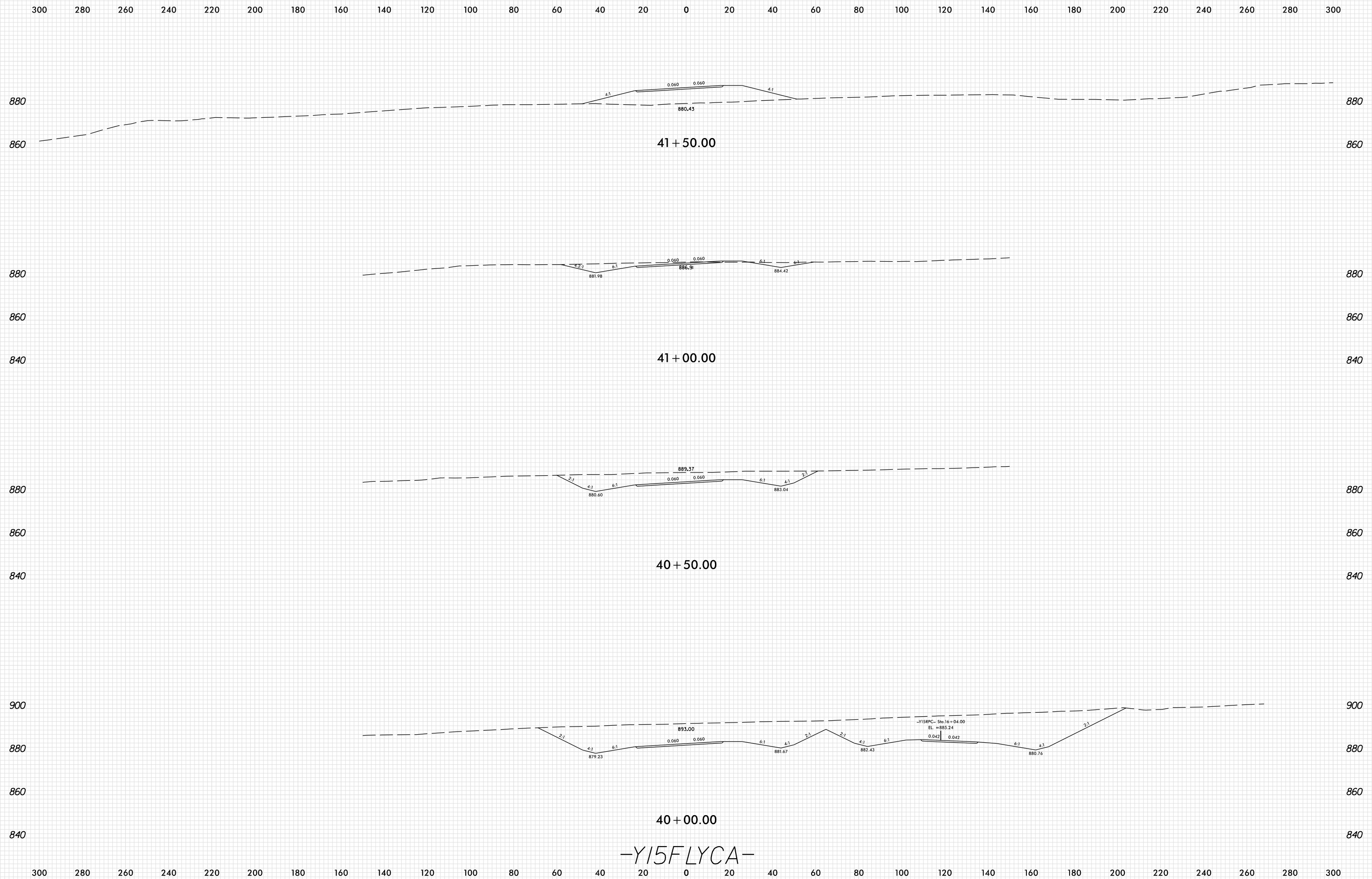

-Y15FLYCA-

PLOT DRIVER: NCD01\_pdf\_color\_eng\_100.plt  
 USER: SPEREIRA  
 DATE: 6/10/2021  
 TIME: 2:27:42 PM  
 FILE: \

8/23/99

0 10 20	PROJ. REFERENCE NO.	SHEET NO.
	U-2579AB	X-490

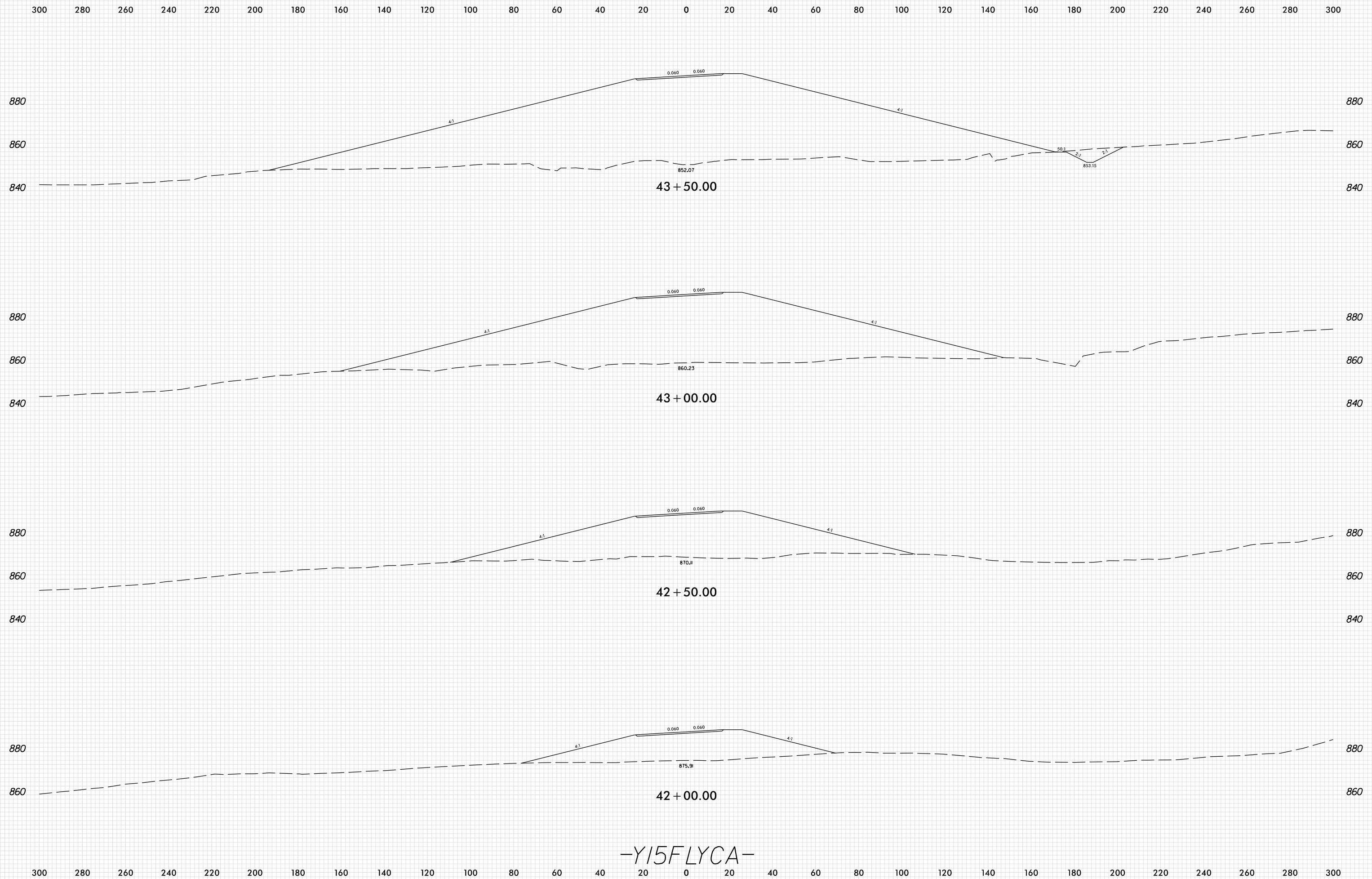

-Y15FLYCA-

PLOT DRIVER: NCDOT\_pdf\_color\_eng\_100.plt  
 USER: SPEREIRA  
 DATE: 6/10/2021  
 TIME: 2:27:43 PM  
 FILE: \

8/23/99

0 10 20	PROJ. REFERENCE NO.	SHEET NO.
	U-2579AB	X-491

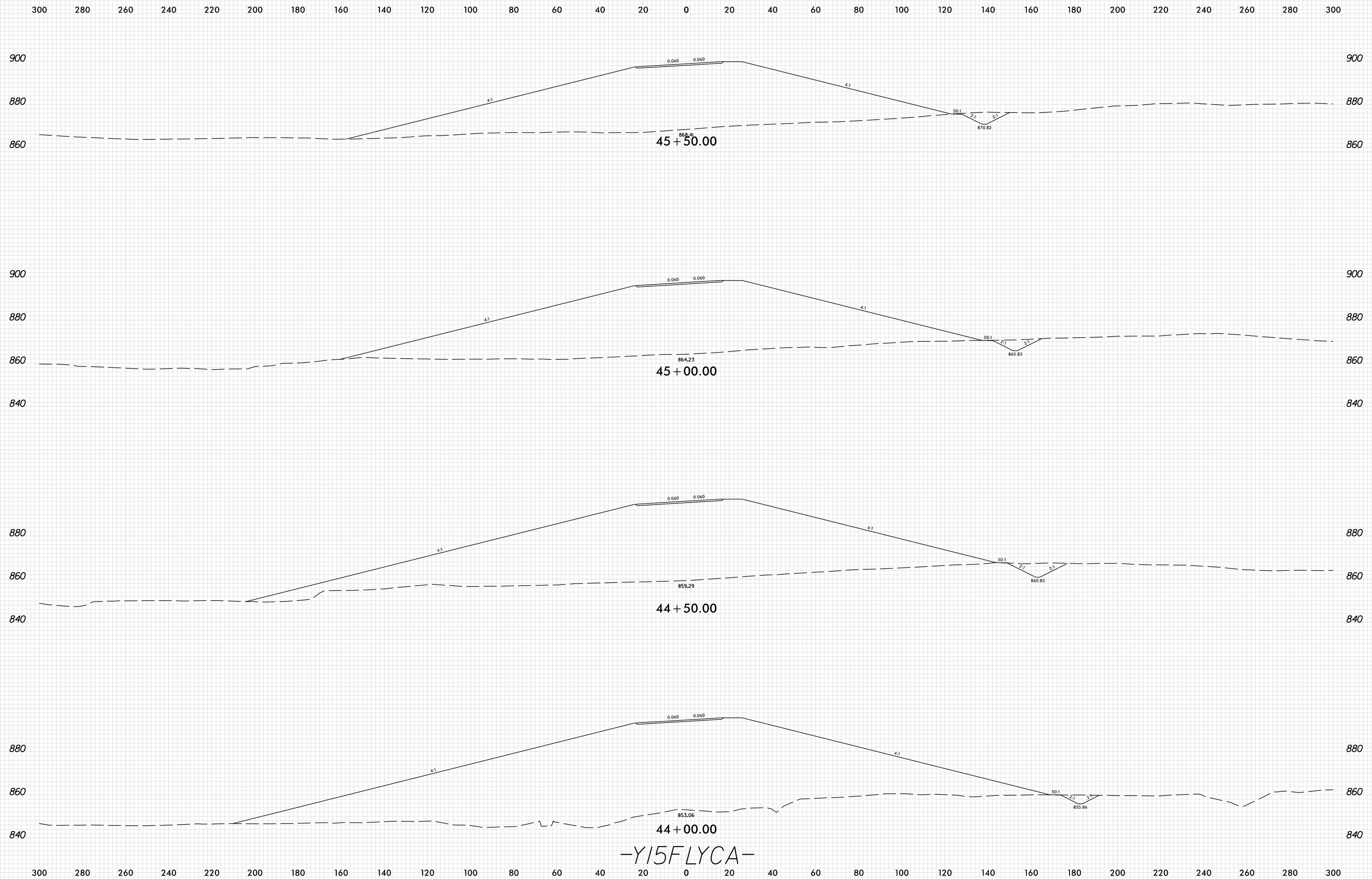

-Y15FLYCA-

PLOT DRIVER: NCDOT\_pdf\_color\_eng\_100.plt  
 USER: SPEREIRA  
 DATE: 6/10/2021  
 TIME: 2:27:43 PM  
 FILE: \

8/23/99

0 10 20	PROJ. REFERENCE NO.	SHEET NO.
	U-2579AB	X-492

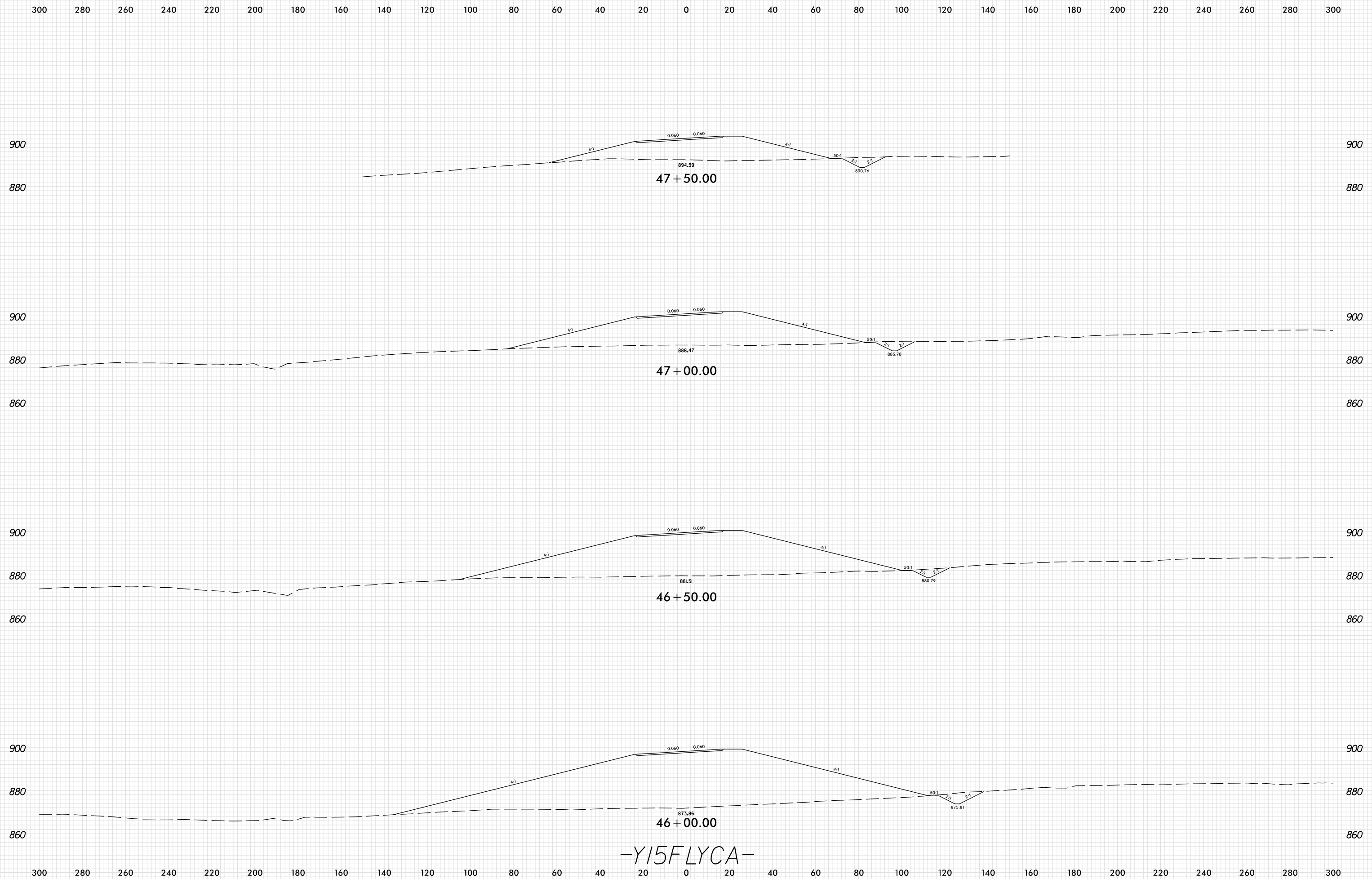

PLOT DRIVER: NCD01\_pdf\_color\_eng\_100.plt  
 USER: SPEREIRA  
 DATE: 6/10/2021  
 TIME: 2:27:44 PM  
 FILE: \



8/23/99



PROJ. REFERENCE NO.	SHEET NO.
U-2579AB	X-493

300 280 260 240 220 200 180 160 140 120 100 80 60 40 20 0 20 40 60 80 100 120 140 160 180 200 220 240 260 280 300

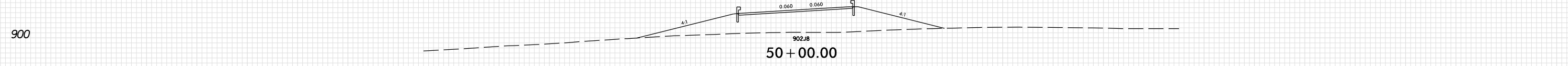

900 880 900 880

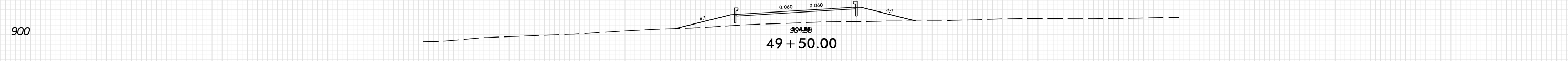

900 880 900 880

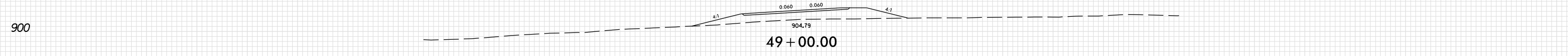

900 880 900 880

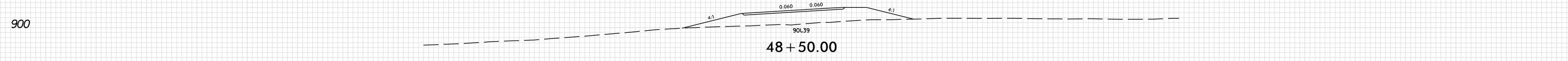

900 880 900 880

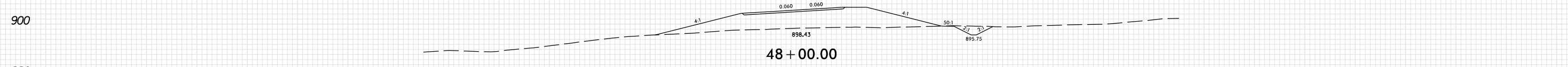

900 880 900 880

-Y15FLYCA-

300 280 260 240 220 200 180 160 140 120 100 80 60 40 20 0 20 40 60 80 100 120 140 160 180 200 220 240 260 280 300

PLOT DRIVER: NCD01\_pdf\_color\_eng\_100.plt  
 USER: SPEREIRA  
 DATE: 6/10/2021  
 TIME: 2:27:45 PM  
 FILE: \

8/23/99

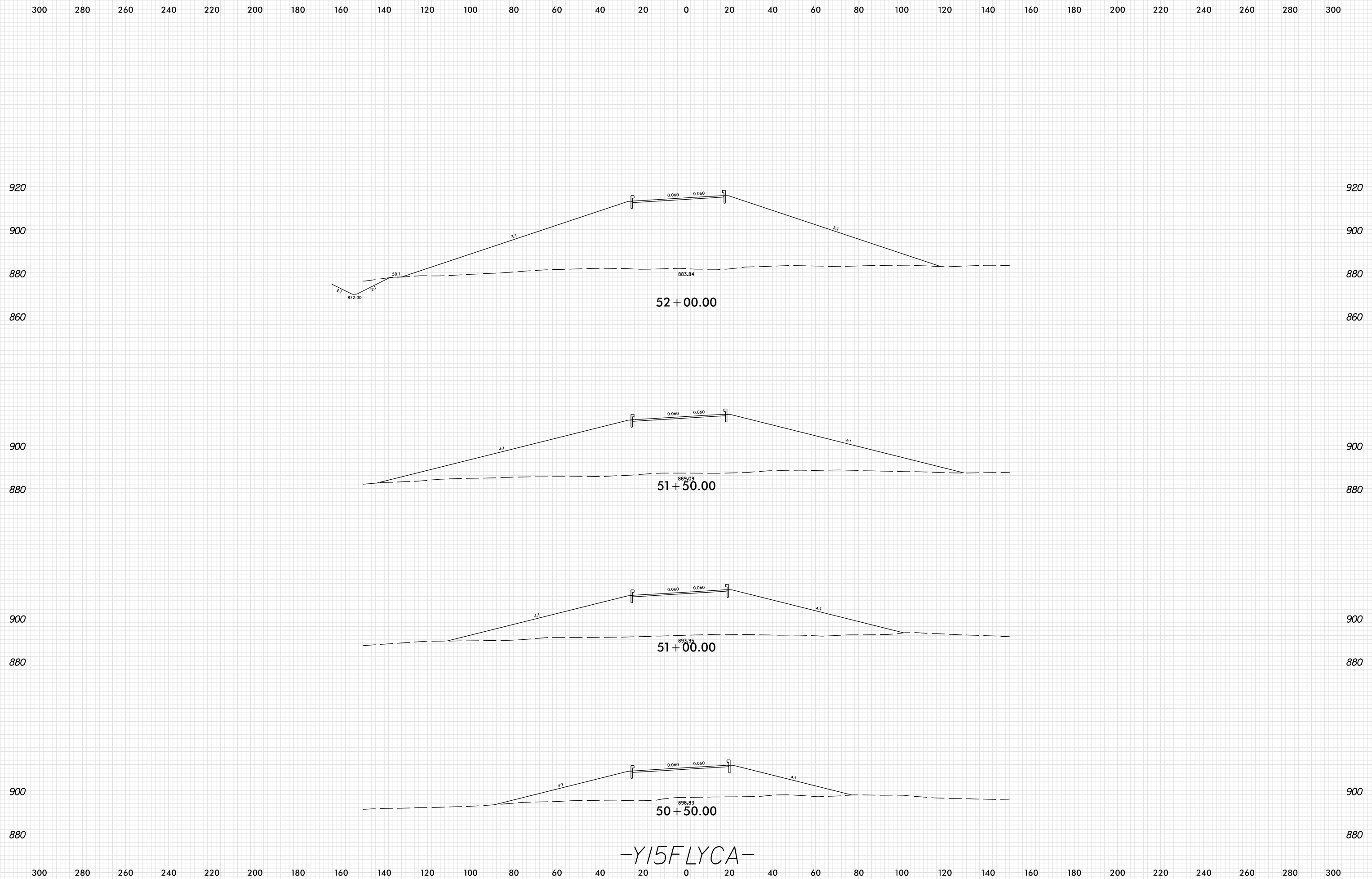

-Y15FLYCA-

PLOT DRIVER: NCD01\_pdf\_color\_eng\_100.plt  
 USER: SPEREIRA  
 DATE: 6/10/2021  
 TIME: 2:27:45 PM  
 FILE: \

8/23/99

0 10 20	PROJ. REFERENCE NO.	SHEET NO.
	U-2579AB	X-495

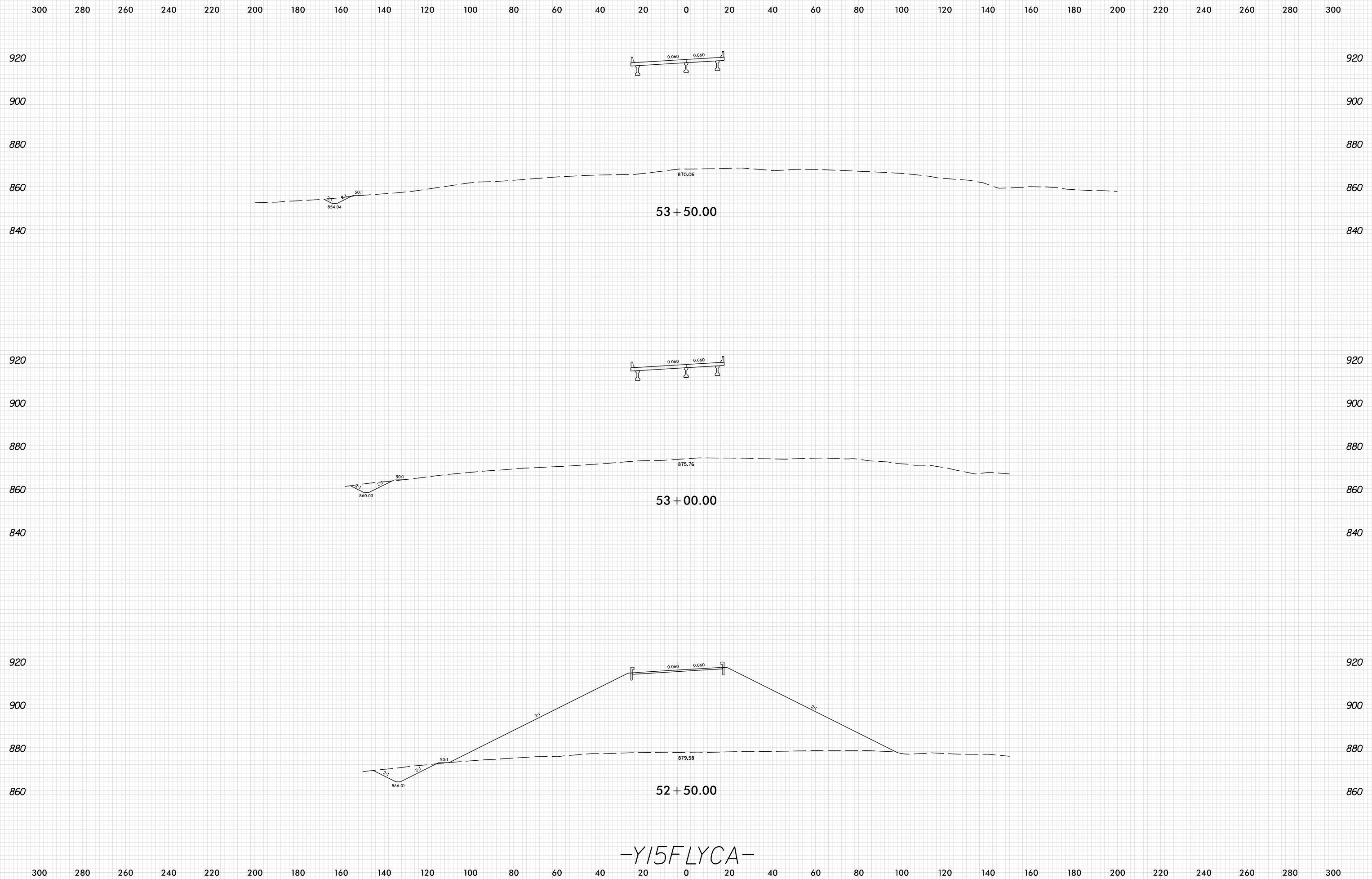

-Y15FLYCA-

PLOT DRIVER: NCDOT\_pdf\_color\_eng\_100.plt  
 USER: SPEREIRA  
 DATE: 6/10/2021  
 TIME: 2:27:46 PM  
 FILE: \

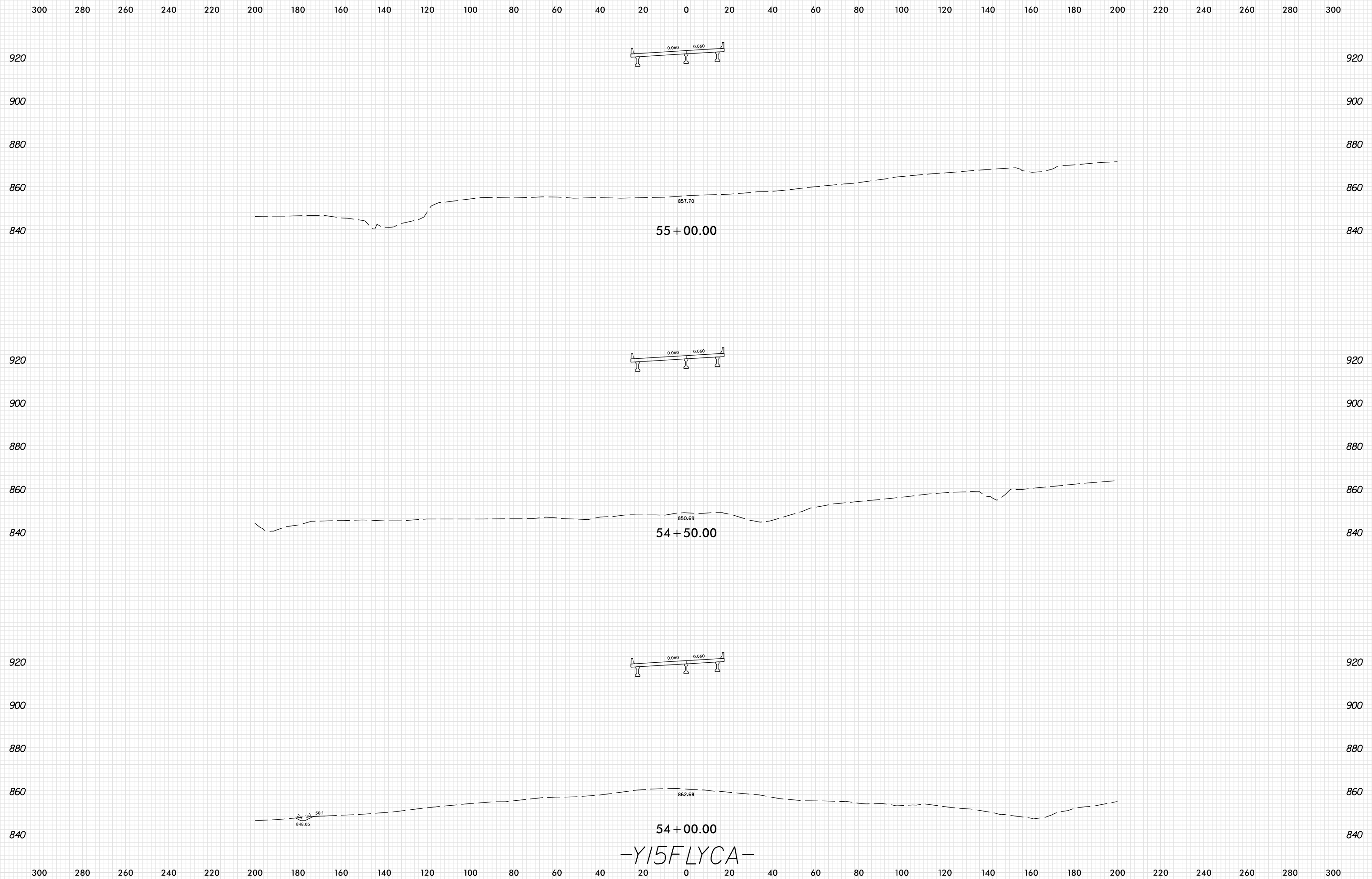

-Y15FLYCA-

8/23/99

0 10 20	PROJ. REFERENCE NO.	SHEET NO.
	U-2579AB	X-497

300 280 260 240 220 200 180 160 140 120 100 80 60 40 20 0 20 40 60 80 100 120 140 160 180 200 220 240 260 280 300

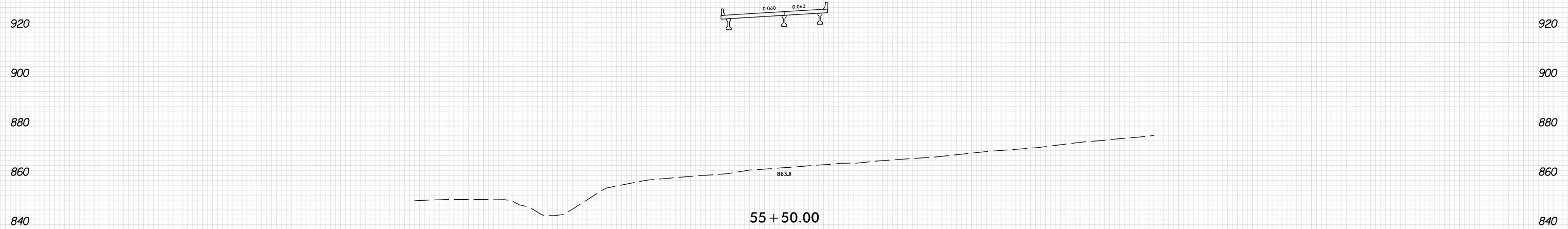
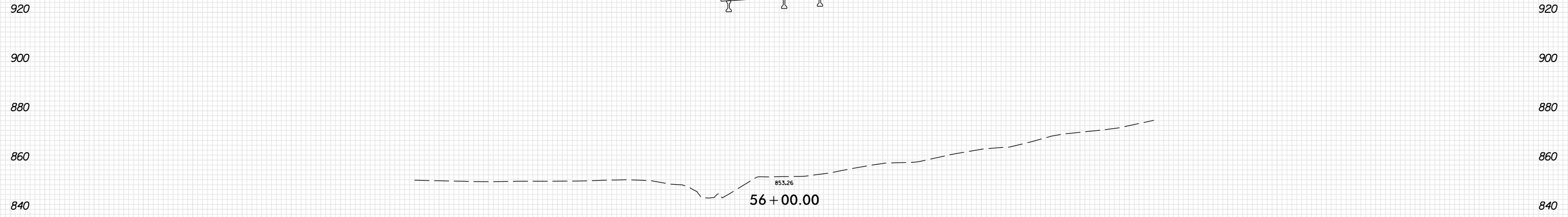

-Y15FLYCA-

300 280 260 240 220 200 180 160 140 120 100 80 60 40 20 0 20 40 60 80 100 120 140 160 180 200 220 240 260 280 300

PLOT DRIVER: NCDOT\_pdf\_color\_eng\_100.plt  
 USER: SPEREIRA  
 DATE: 6/10/2021  
 TIME: 2:27:47 PM  
 FILE: \

8/23/99

0 10 20	PROJ. REFERENCE NO.	SHEET NO.
	U-2579AB	X-498

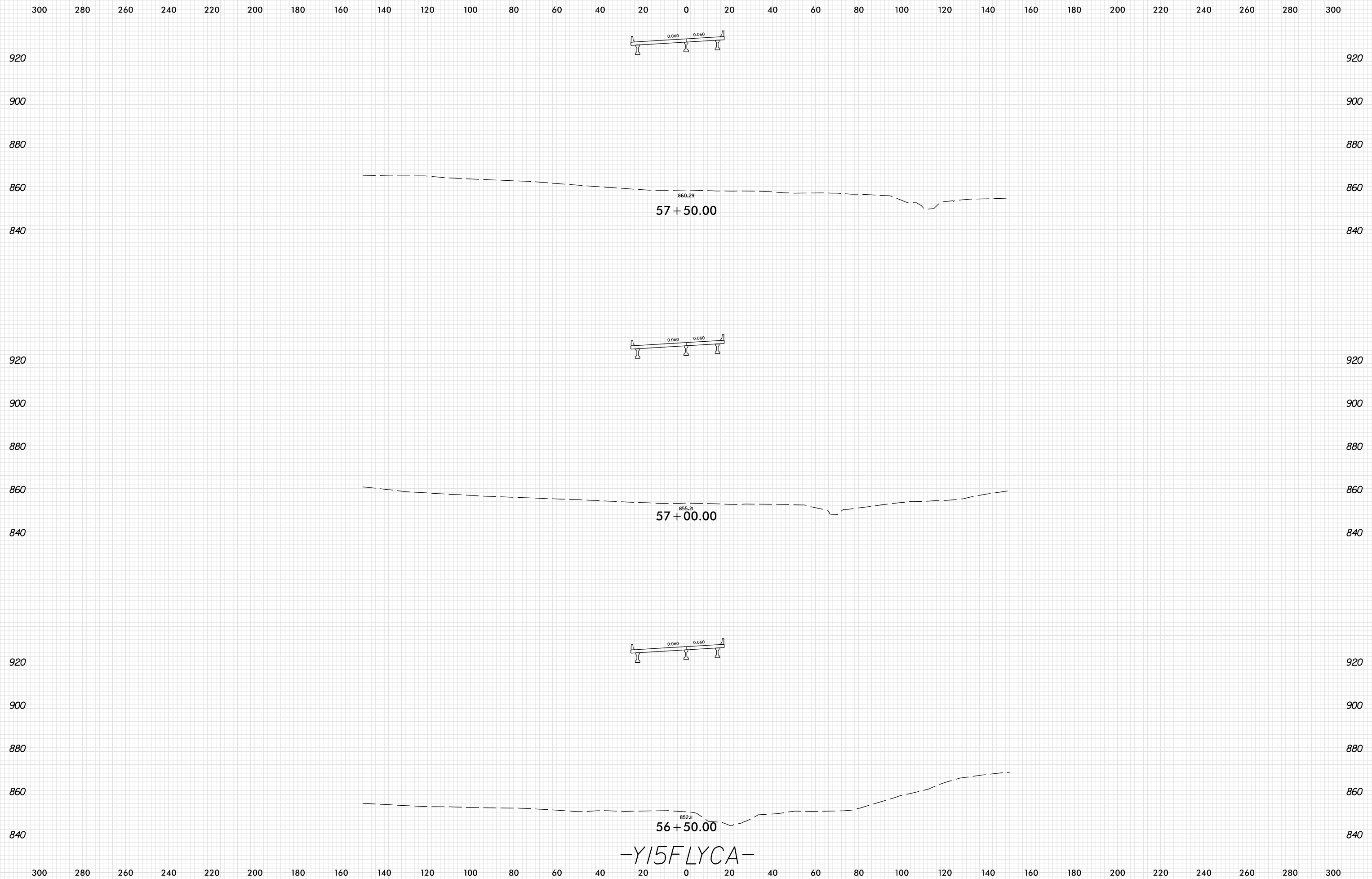

-Y15FLYCA-

PLOT DRIVER: NCD01\_pdf\_color\_eng\_100.plt  
 USER: SPEREIRA  
 DATE: 6/10/2021  
 TIME: 2:27:48 PM

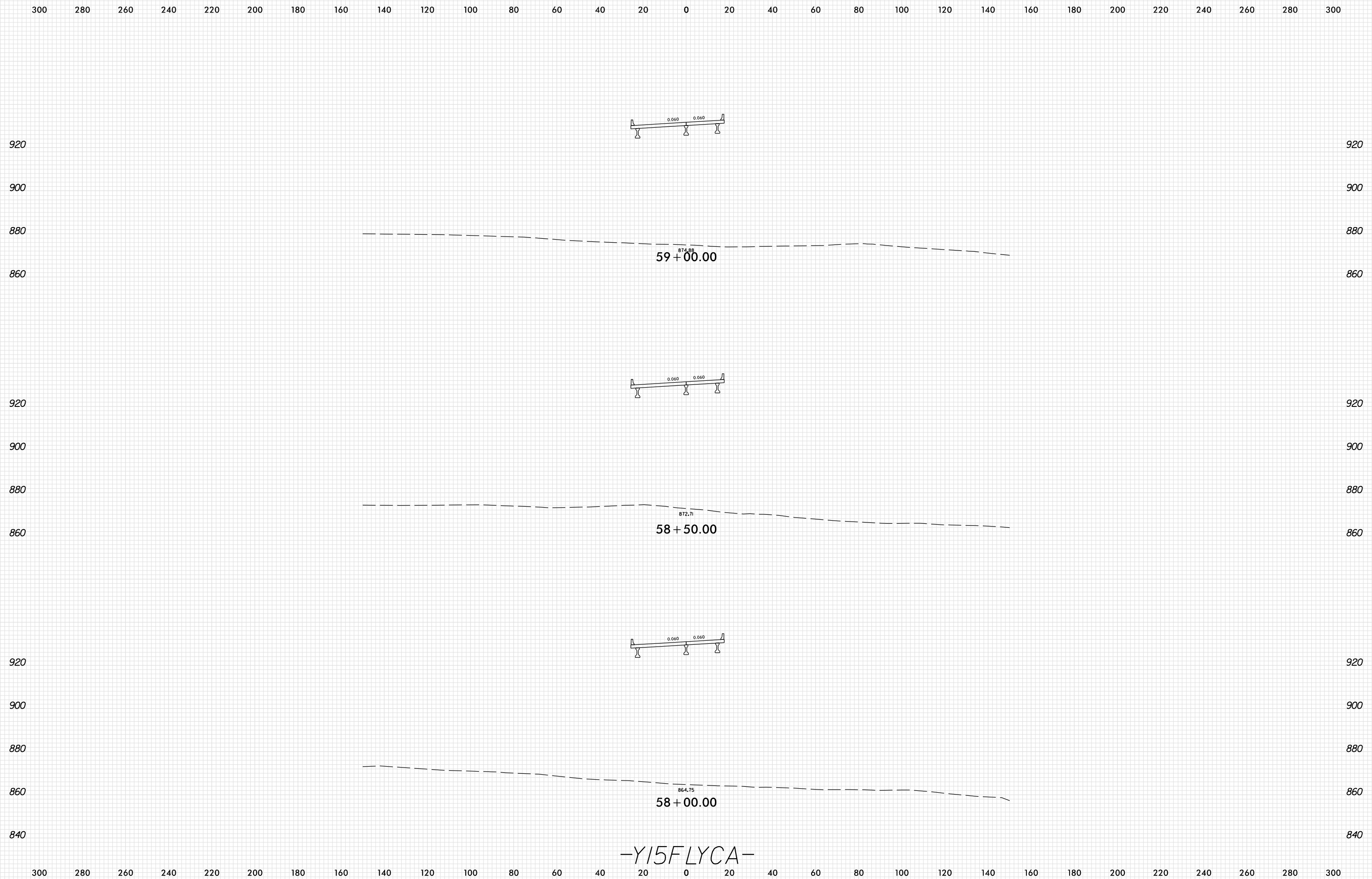

300 280 260 240 220 200 180 160 140 120 100 80 60 40 20 0 20 40 60 80 100 120 140 160 180 200 220 240 260 280 300

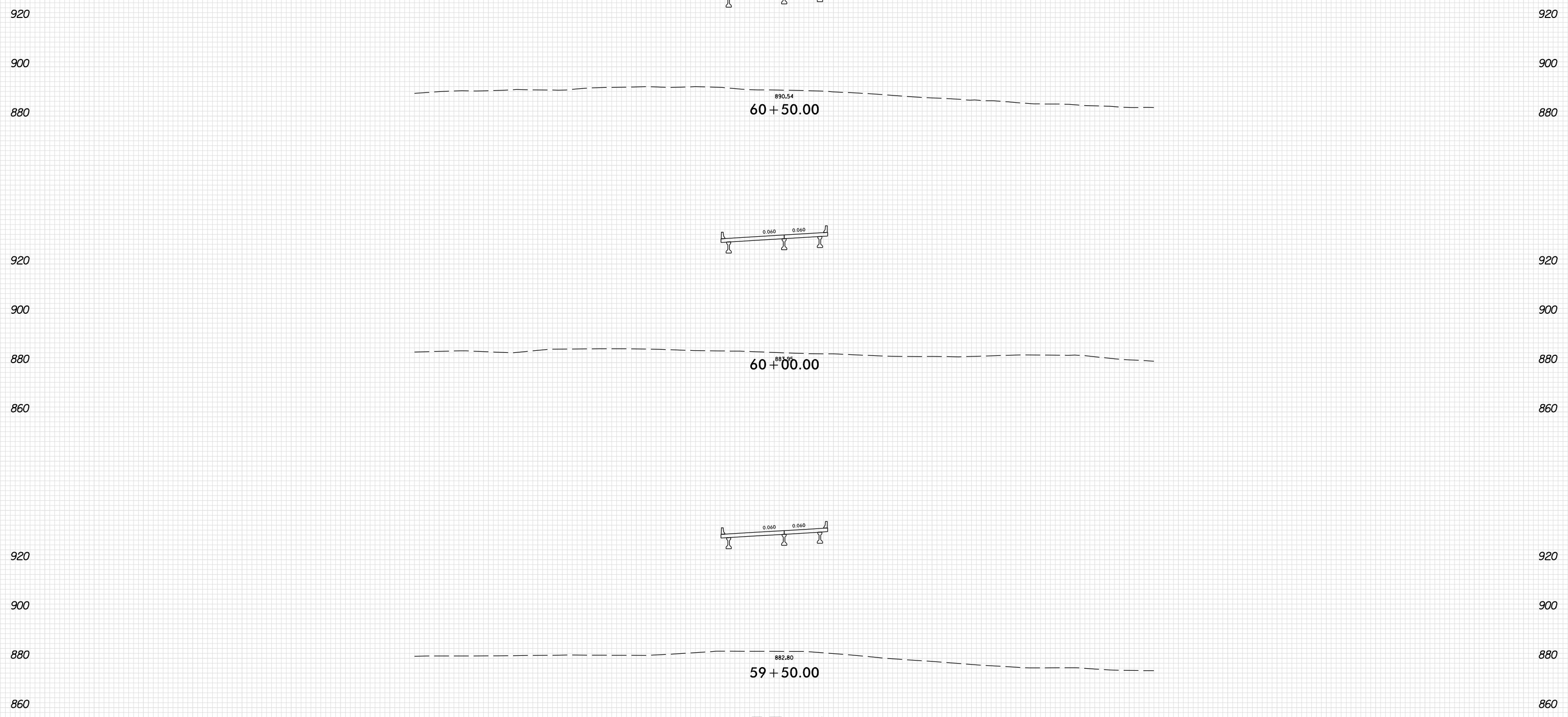

-Y15FLYCA-



8/23/99

0 10 20	PROJ. REFERENCE NO.	SHEET NO.
	U-2579AB	X-501

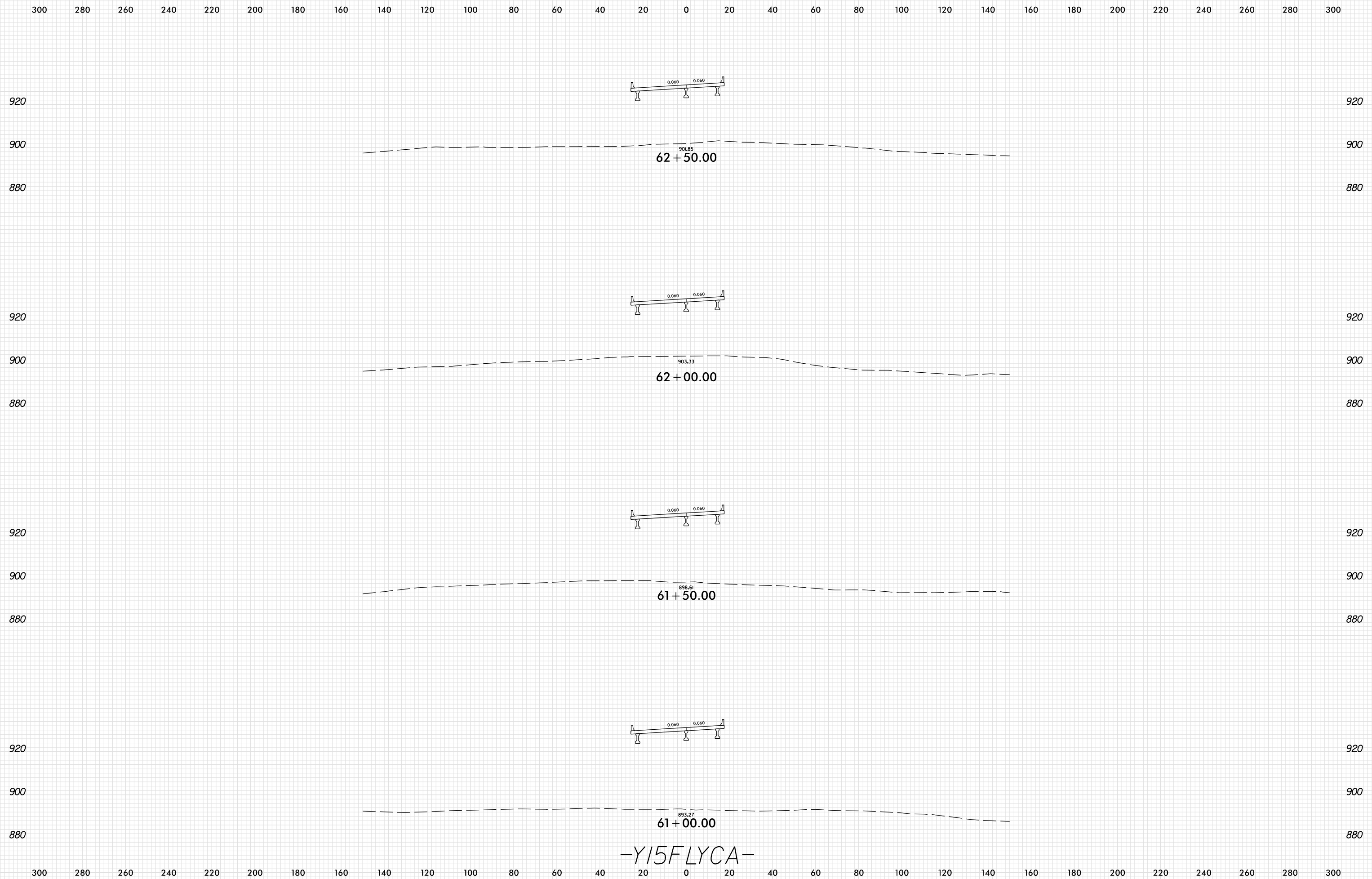

PLOT DRIVER: NCD01\_.pdf\_color\_eng\_100.plt  
 USER: SPEREIRA  
 DATE: 6/10/2021  
 TIME: 2:27:50 PM

-Y15FLYCA-

8/23/99

0 10 20	PROJ. REFERENCE NO.	SHEET NO.
	U-2579AB	X-502

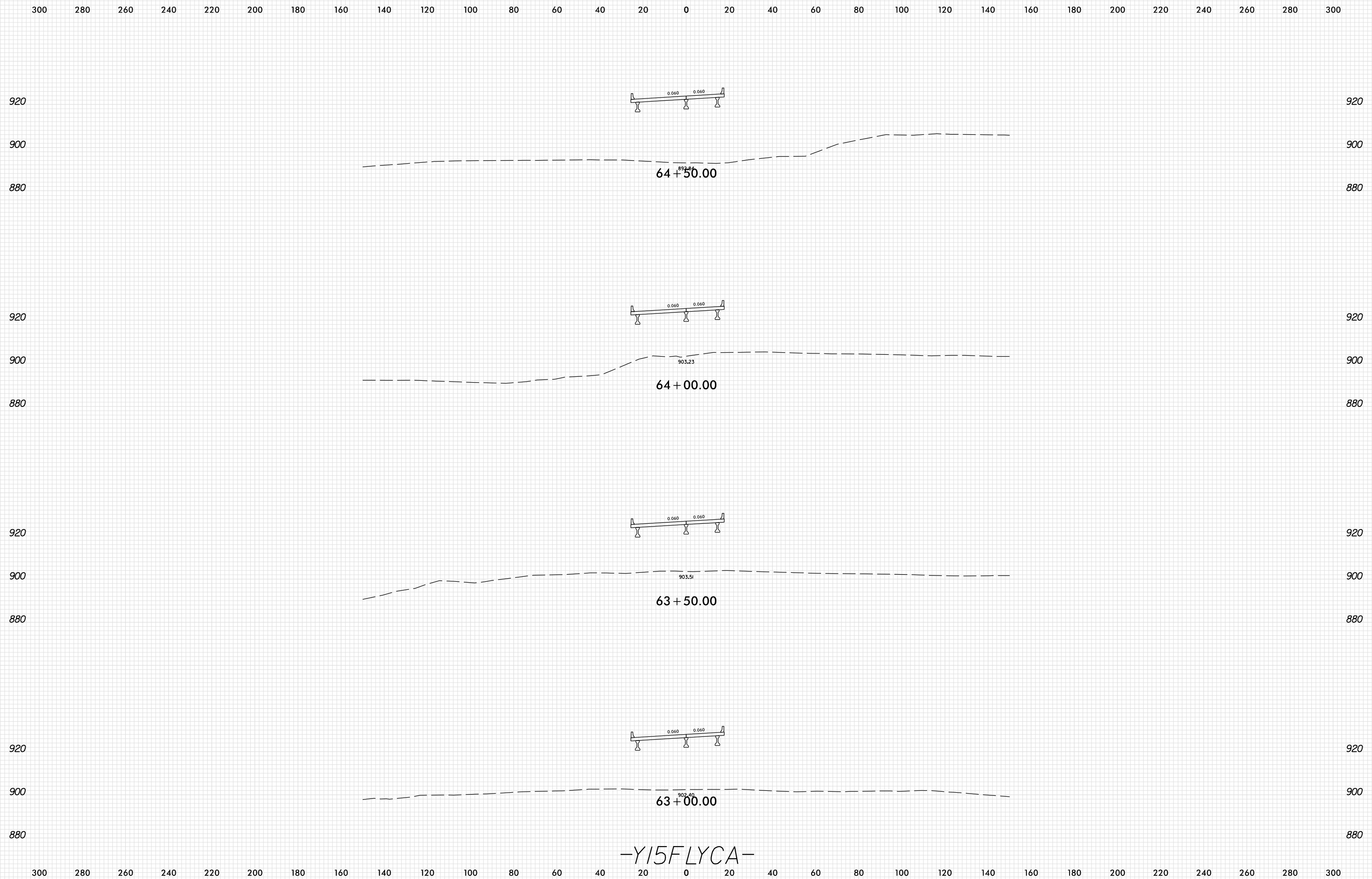

PLOT DRIVER: NCD01\_pdf\_color\_eng\_100.plt  
 USER: SPEREIRA  
 DATE: 6/10/2021  
 TIME: 2:27:51 PM  
 FILE: \

-Y15FLYCA-

8/23/99

0 10 20	PROJ. REFERENCE NO.	SHEET NO.
	U-2579AB	X-503

300 280 260 240 220 200 180 160 140 120 100 80 60 40 20 0 20 40 60 80 100 120 140 160 180 200 220 240 260 280 300

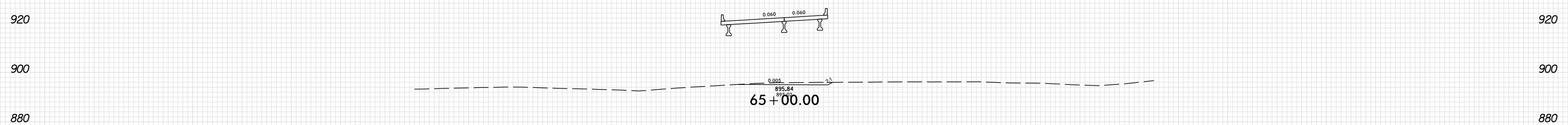
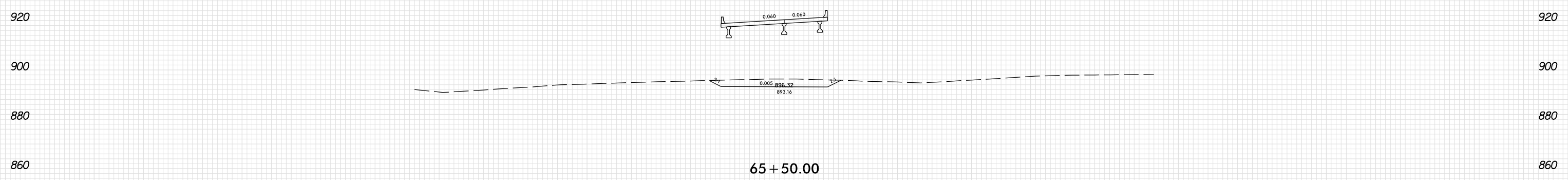
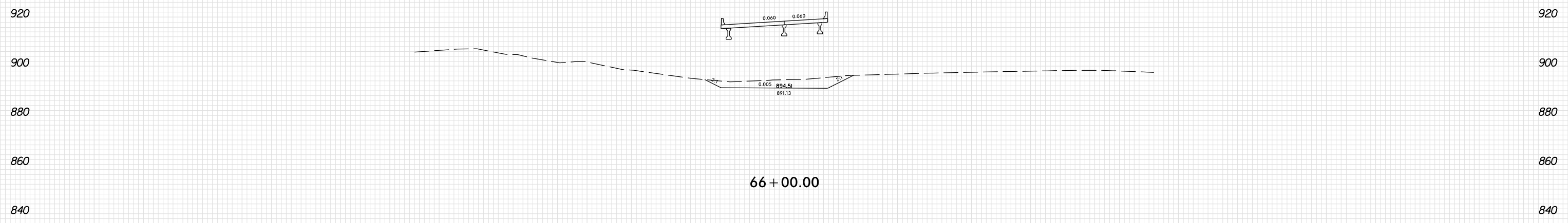

-Y15FLYCA-

300 280 260 240 220 200 180 160 140 120 100 80 60 40 20 0 20 40 60 80 100 120 140 160 180 200 220 240 260 280 300

PLOT DRIVER: NCDOT\_pdf\_color\_eng\_100.plt  
 USER: SPEREIRA  
 DATE: 6/10/2021  
 TIME: 2:27:51 PM  
 FILE: \

300 280 260 240 220 200 180 160 140 120 100 80 60 40 20 0 20 40 60 80 100 120 140 160 180 200 220 240 260 280 300

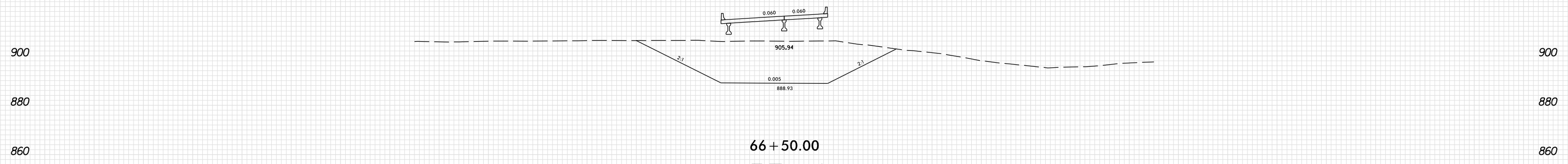
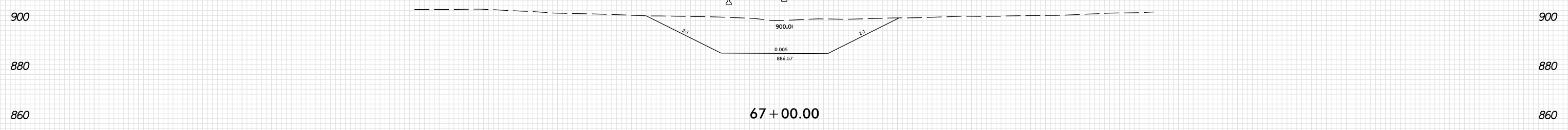
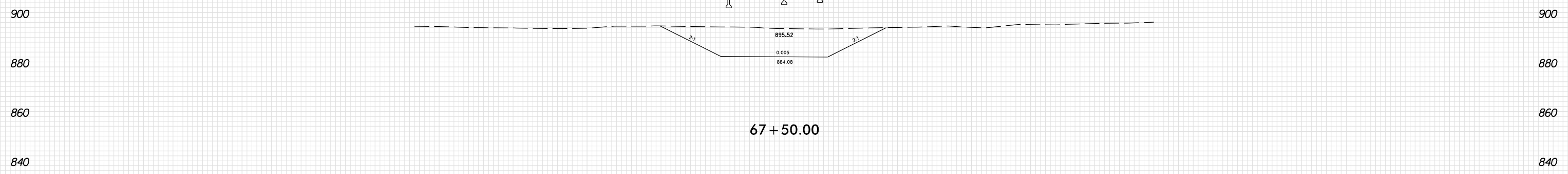

-Y15FLYCA-

300 280 260 240 220 200 180 160 140 120 100 80 60 40 20 0 20 40 60 80 100 120 140 160 180 200 220 240 260 280 300

8/23/99

0 10 20	PROJ. REFERENCE NO.	SHEET NO.
	U-2579AB	X-505

300 280 260 240 220 200 180 160 140 120 100 80 60 40 20 0 20 40 60 80 100 120 140 160 180 200 220 240 260 280 300

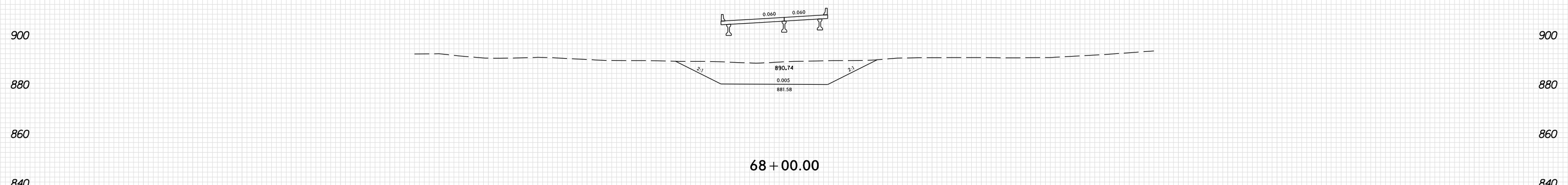
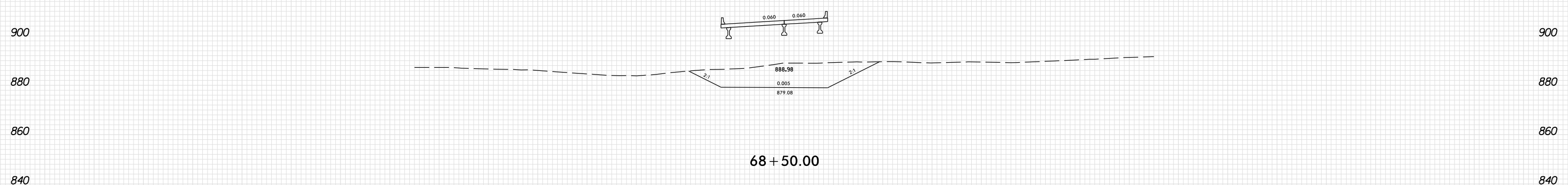
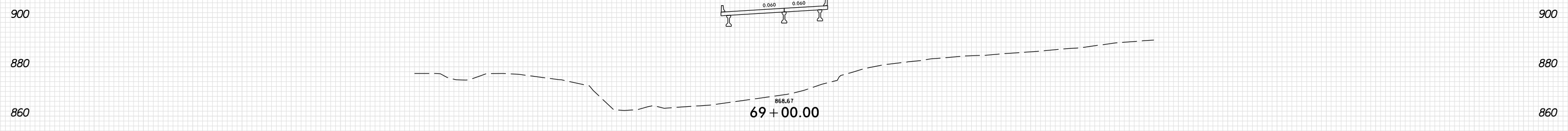

-Y15FLYCA-

300 280 260 240 220 200 180 160 140 120 100 80 60 40 20 0 20 40 60 80 100 120 140 160 180 200 220 240 260 280 300

PLOT DRIVER: NCD01\_pdf\_color\_eng\_100.plt  
 USER: SPEREIRA  
 DATE: 6/10/2021  
 TIME: 2:27:52 PM  
 FILE: \

8/23/99

0 10 20	PROJ. REFERENCE NO.	SHEET NO.
	U-2579AB	X-506

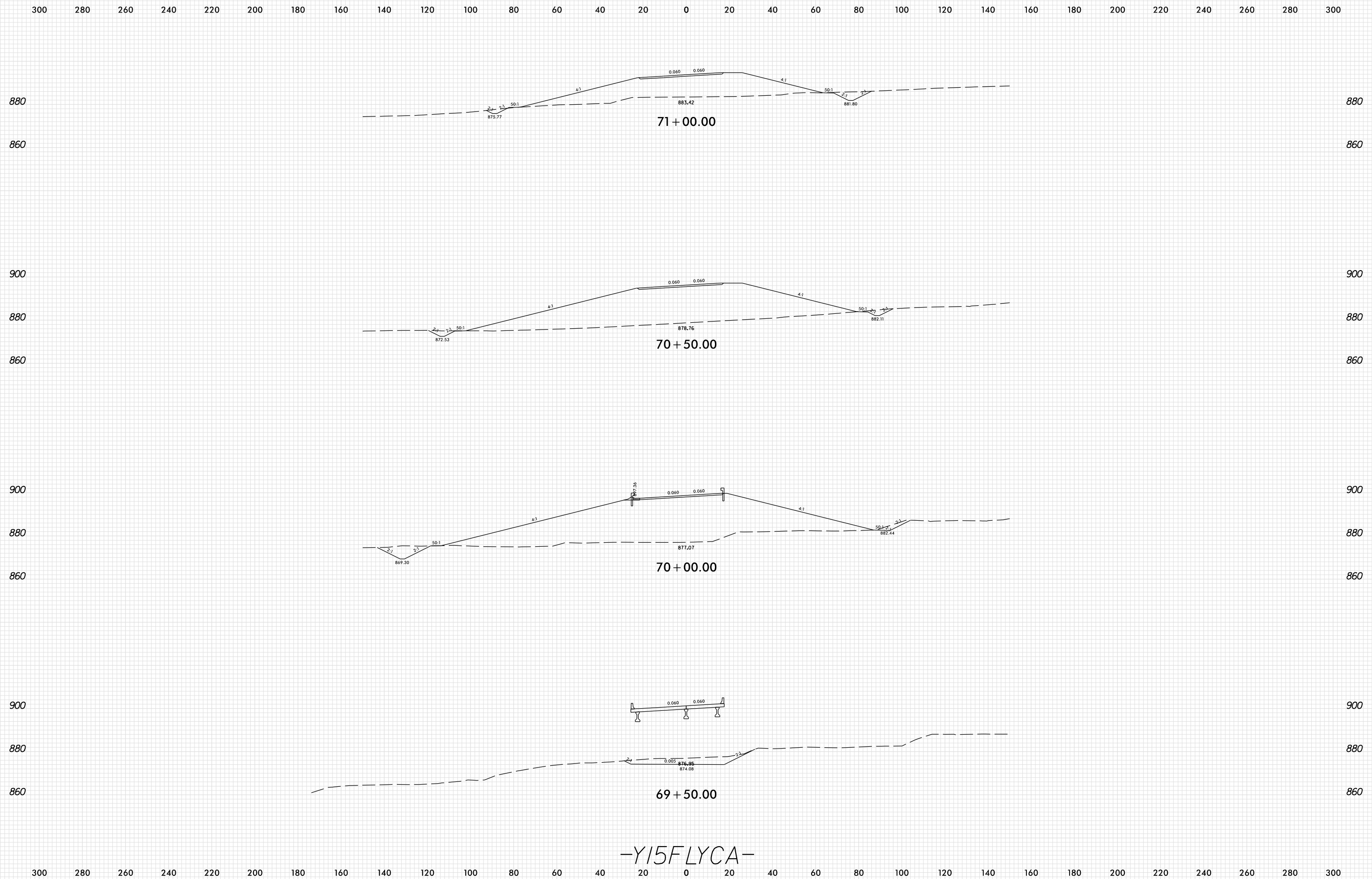

-Y15FLYCA-

PLOT DRIVER: NCD01\_pdf\_color\_eng\_100.plt  
 USER: SPEREIRA  
 DATE: 6/10/2021  
 TIME: 2:27:53 PM  
 FILE: \

8/23/99

0 10 20	PROJ. REFERENCE NO.	SHEET NO.
	U-2579AB	X-507

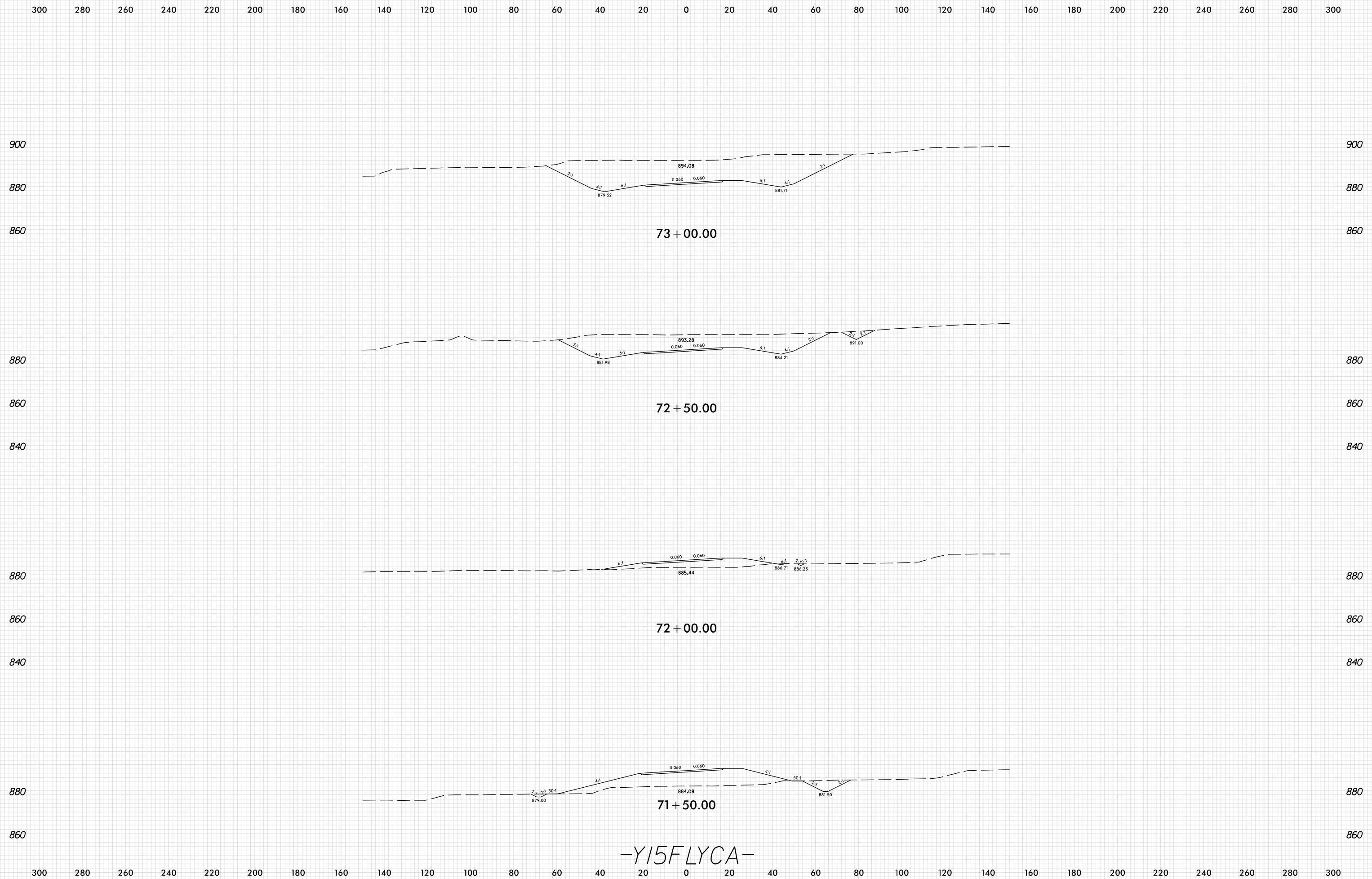

-Y15FLYCA-

PLOT DRIVER: NCDOT\_pdf\_color\_eng\_100.plt  
 USER: SPEREIRA  
 DATE: 6/10/2021  
 TIME: 2:27:54 PM  
 FILE: \

8/23/99

0 10 20	PROJ. REFERENCE NO.	SHEET NO.
	U-2579AB	X-508

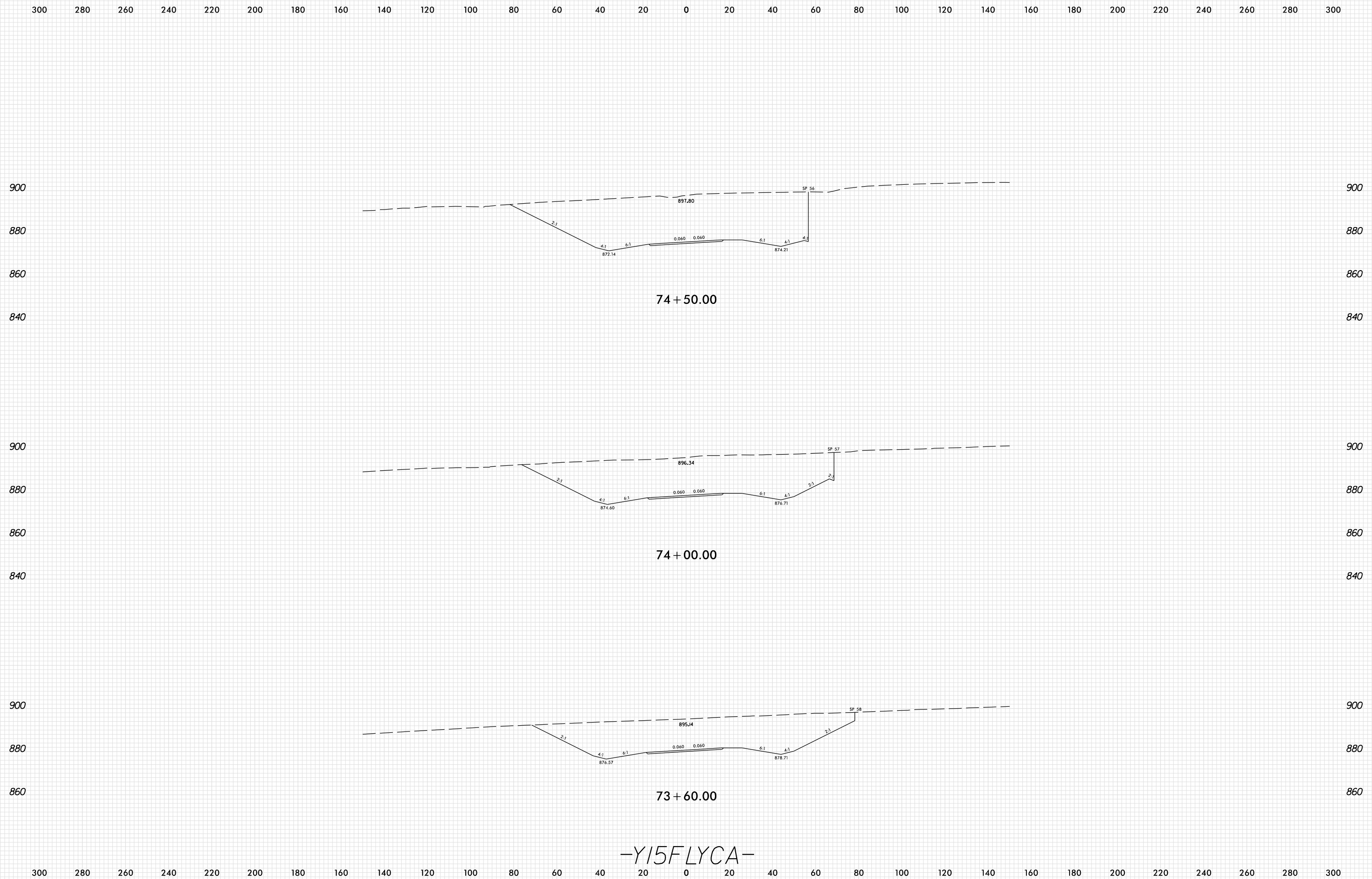

-Y15FLYCA-

PLOT DRIVER: NCD01\_pdf\_color\_eng\_100.plt  
 USER: SPEREIRA  
 DATE: 6/10/2021  
 TIME: 2:27:55 PM  
 FILE: \



8/23/99



PROJ. REFERENCE NO.	SHEET NO.
U-2579AB	X-509

300 280 260 240 220 200 180 160 140 120 100 80 60 40 20 0 20 40 60 80 100 120 140 160 180 200 220 240 260 280 300

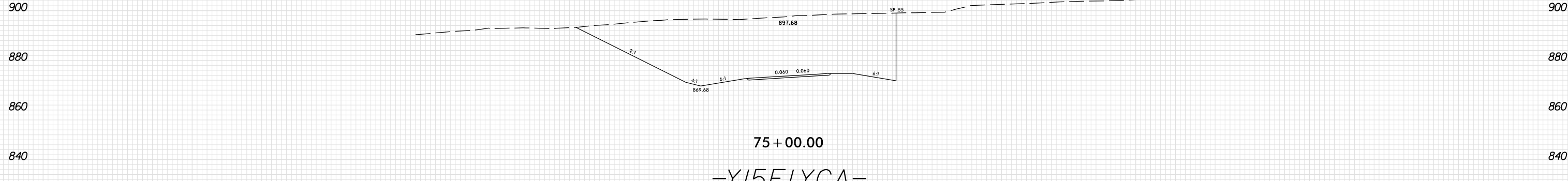
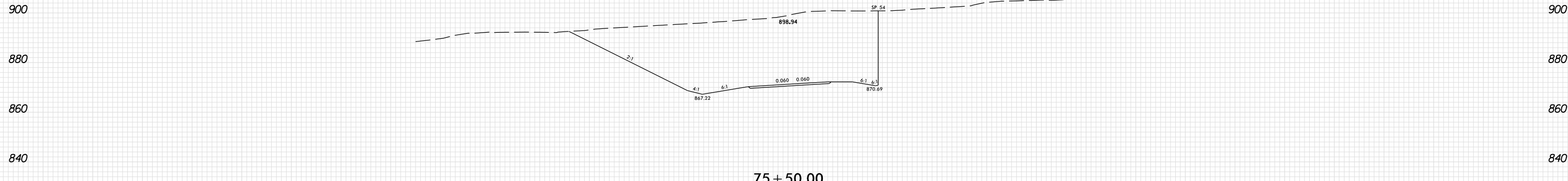
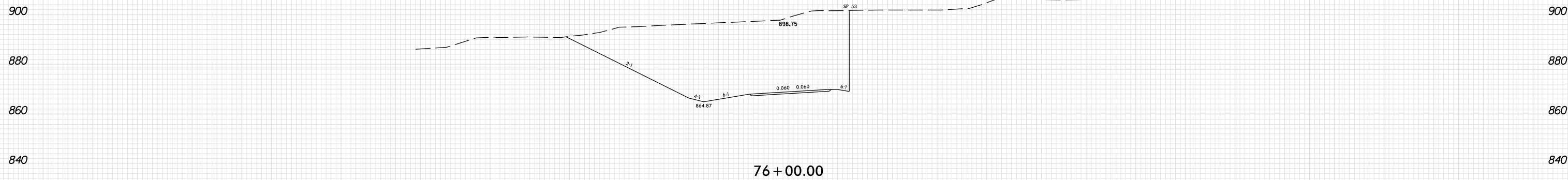

300 280 260 240 220 200 180 160 140 120 100 80 60 40 20 0 20 40 60 80 100 120 140 160 180 200 220 240 260 280 300

-Y15FLYCA-

PLOT DRIVER: NCD01\_pdf\_color\_eng\_100.plt  
 USER: SPEREIRA  
 DATE: 6/10/2021  
 TIME: 2:27:56 PM  
 FILE: \

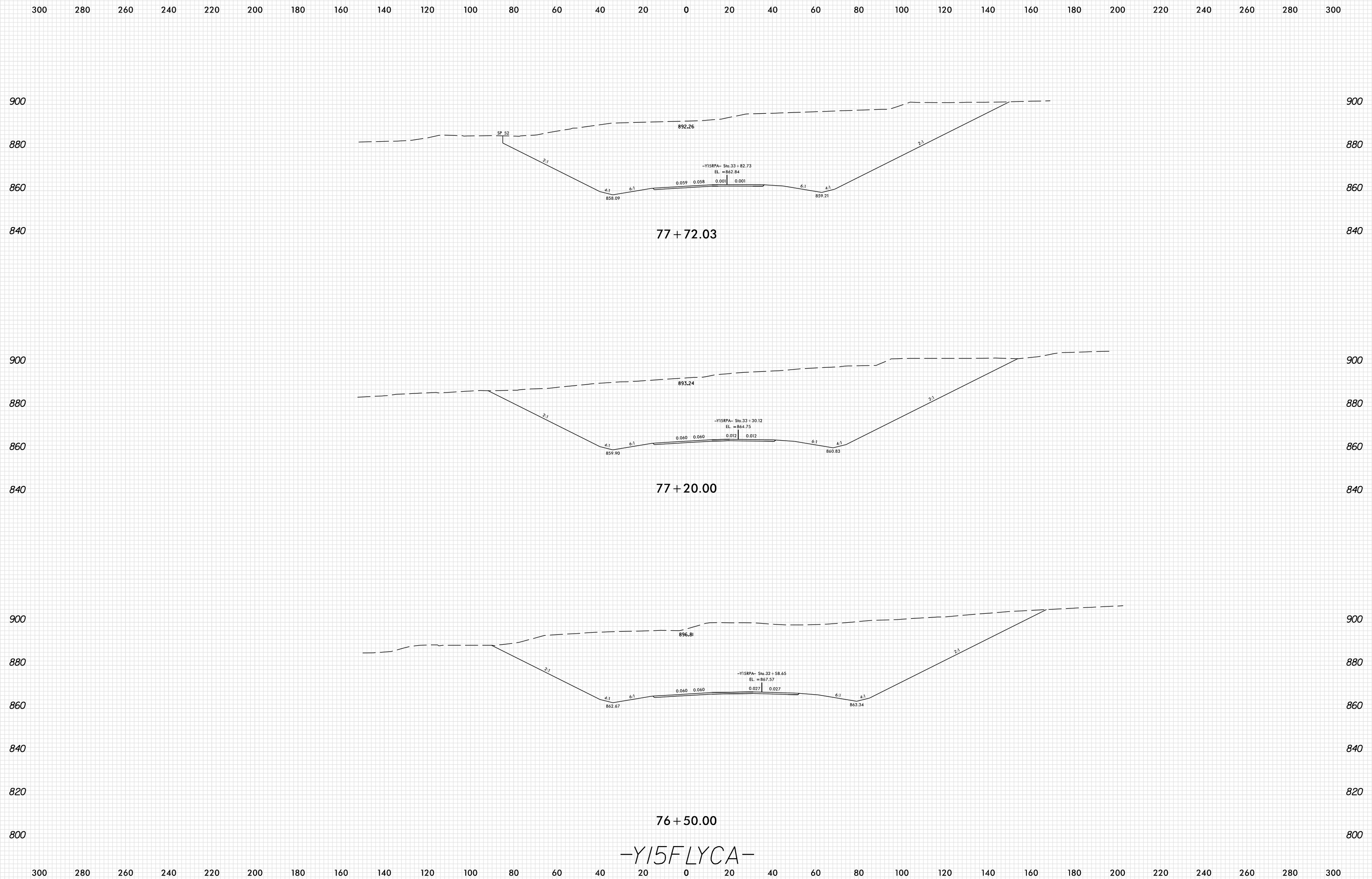

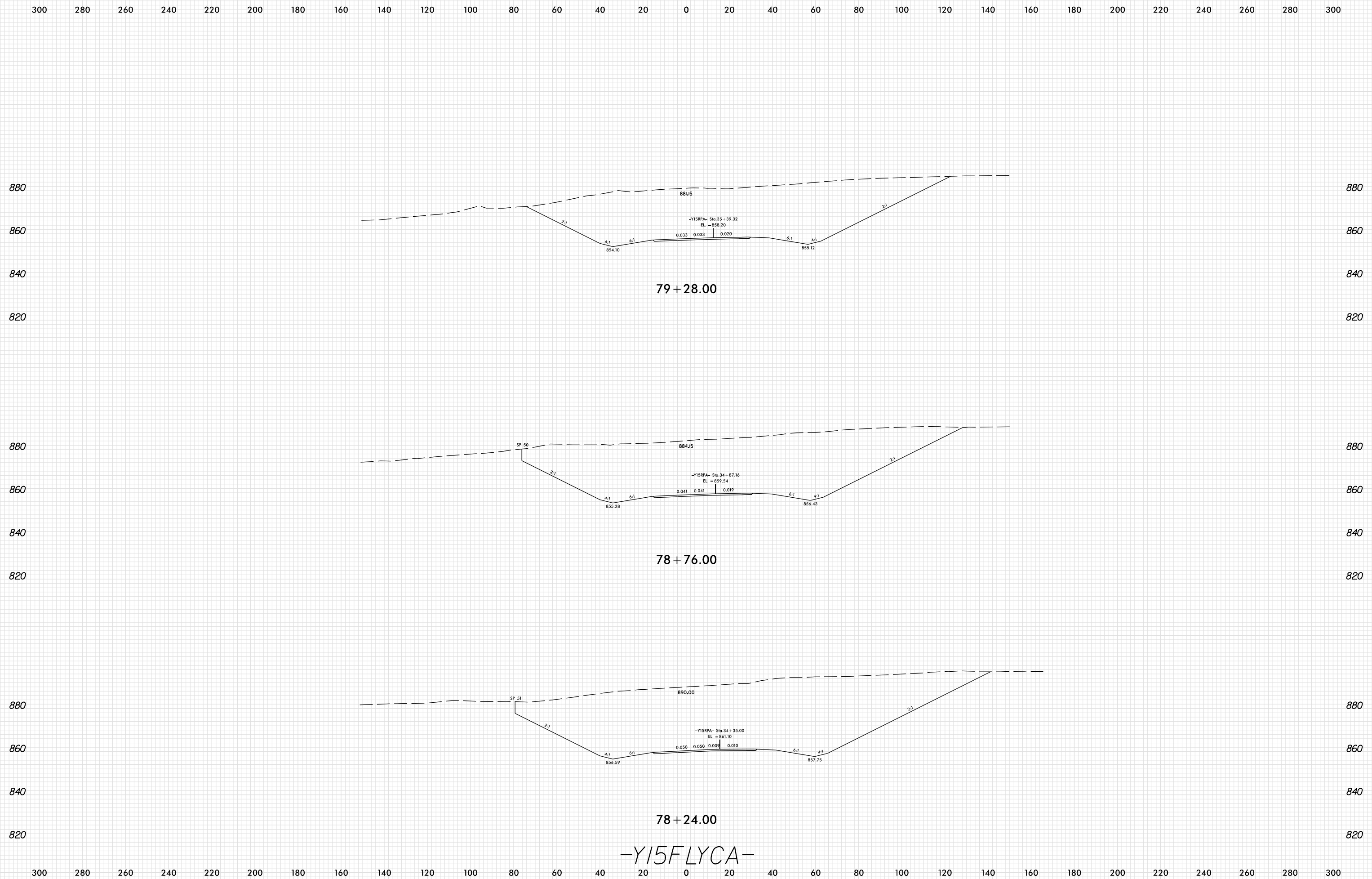

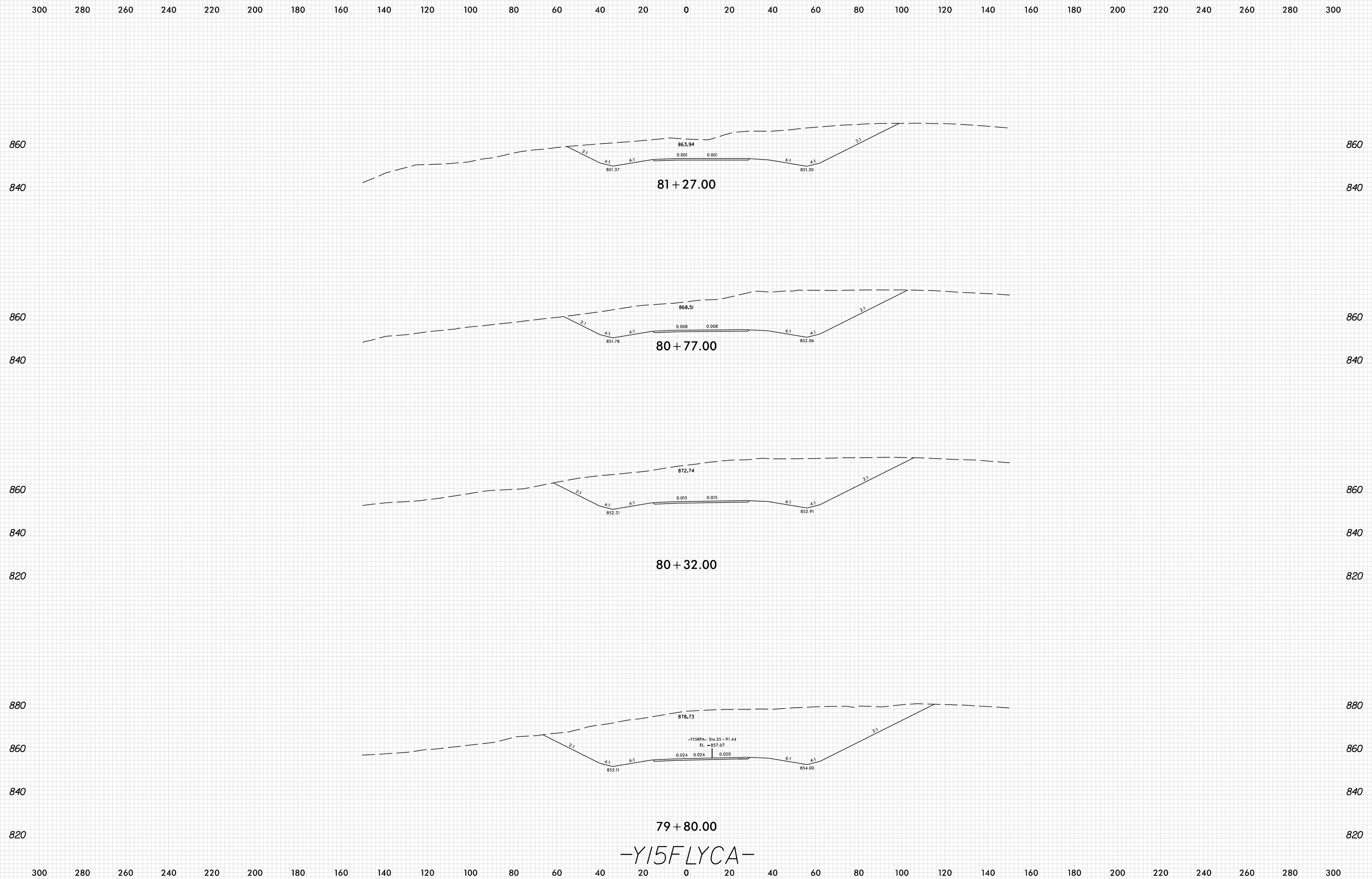

8/23/99



PROJ. REFERENCE NO.	SHEET NO.
U-2579AB	X-513

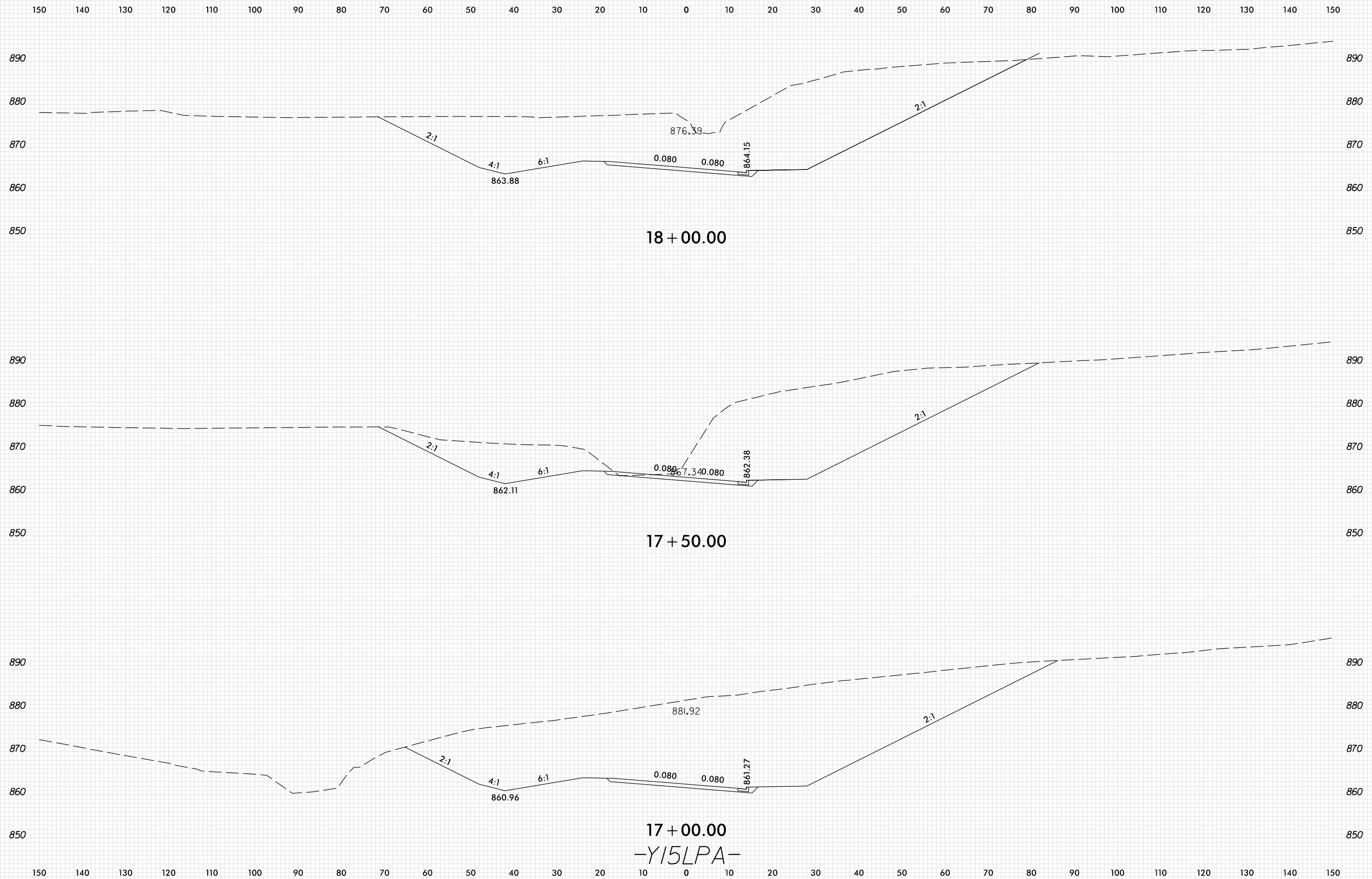

17+00.00  
-Y15LPA-

PLOT DRIVER: NCDOT\_pdf\_color\_eng\_100.plt  
 USER: SPEREIRA  
 DATE: 6/10/2021  
 TIME: 2:28:06 PM  
 FILE: \

8/23/99



PROJ. REFERENCE NO.	SHEET NO.
U-2579AB	X-514

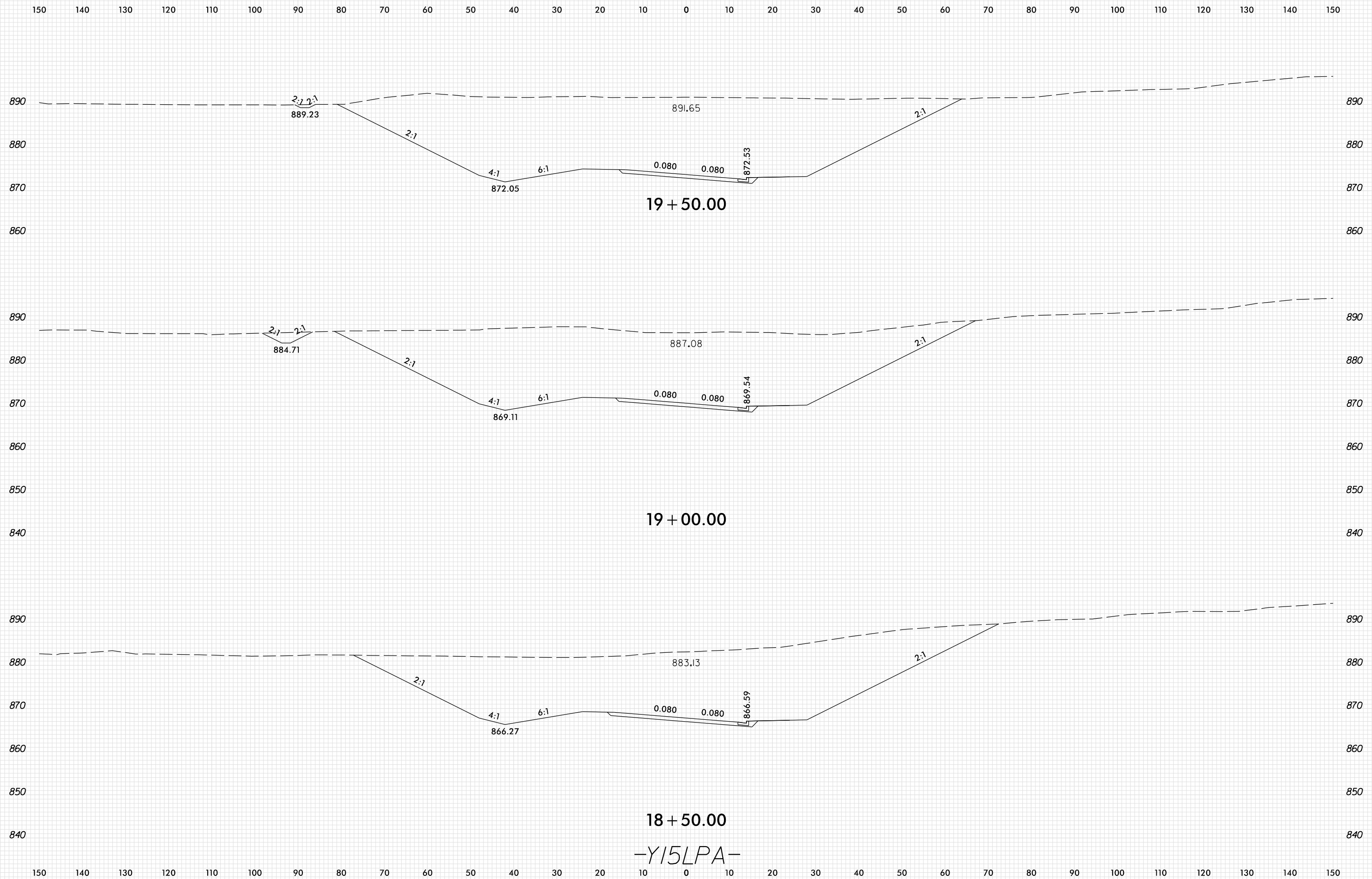

-Y15LPA-

PLOT DRIVER: NCD01\_pdf\_color\_eng\_100.plt  
 USER: SPEREIRA  
 DATE: 6/10/2021  
 TIME: 2:28:06 PM

8/23/99

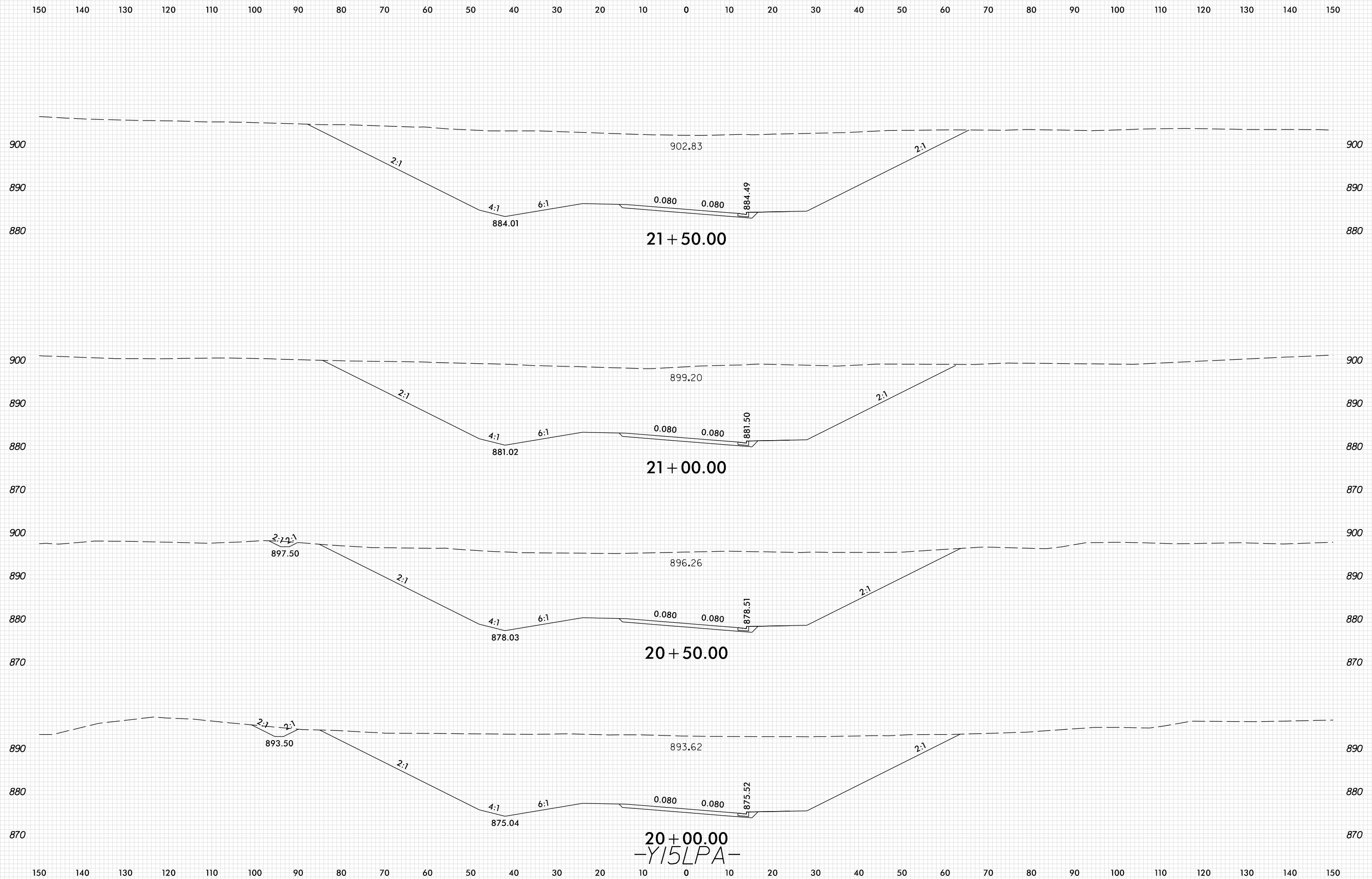

20+00.00  
-Y15LPA-

PLOT DRIVER: NCD01\_pdf\_color\_eng\_100.plt  
USER: SPEREIRA  
DATE: 6/10/2021  
TIME: 2:28:07 PM  
FILE: \

8/23/99

0 5 10	PROJ. REFERENCE NO.	SHEET NO.
	U-2579AB	X-516

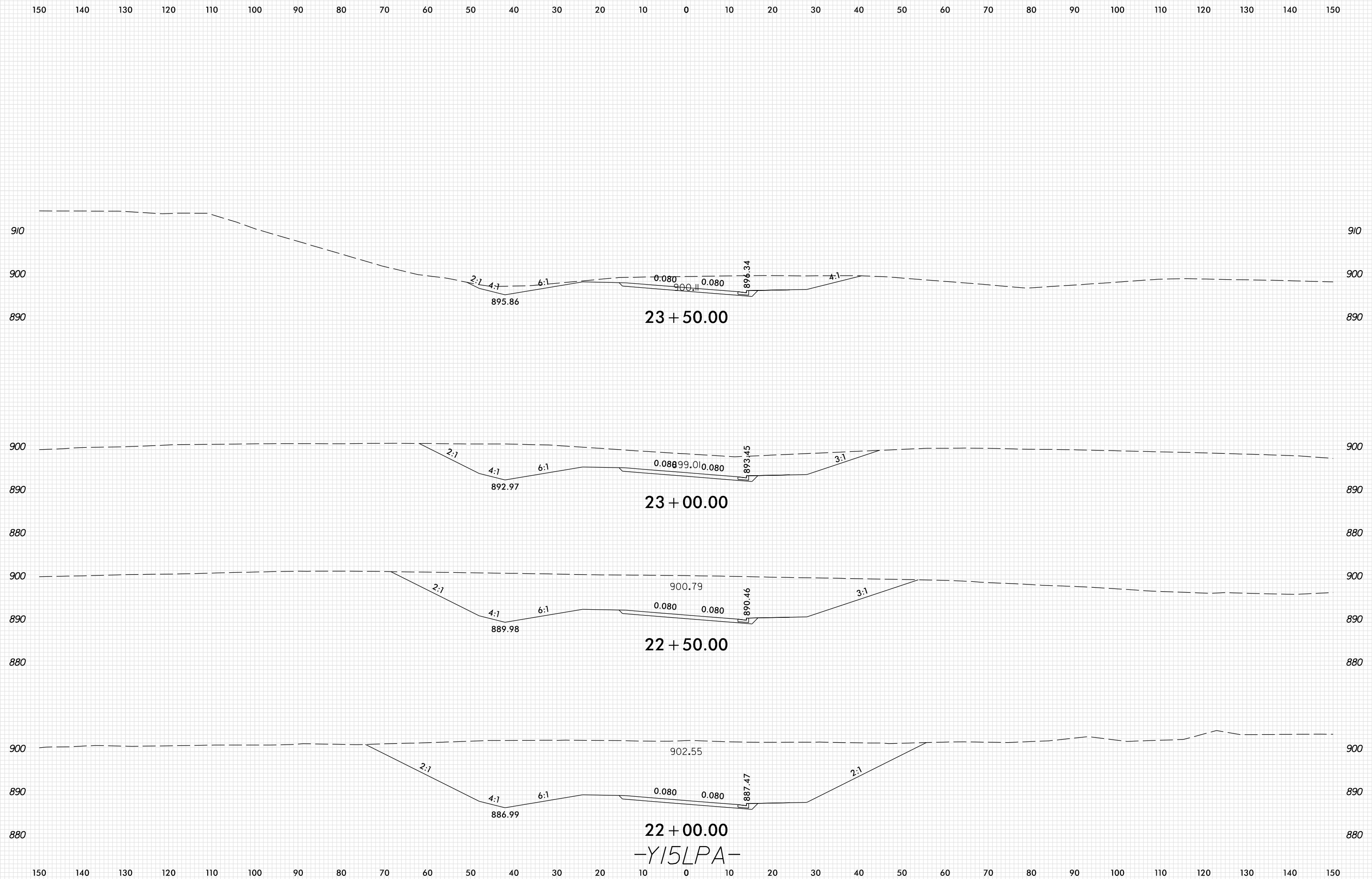

22 + 00.00  
 -Y15LPA-

PLOT DRIVER: NCD01\_pdf\_color\_eng\_100.plt  
 USER: SPEREIRA  
 DATE: 6/10/2021  
 TIME: 2:28:08 PM  
 FILE: \



8/23/99

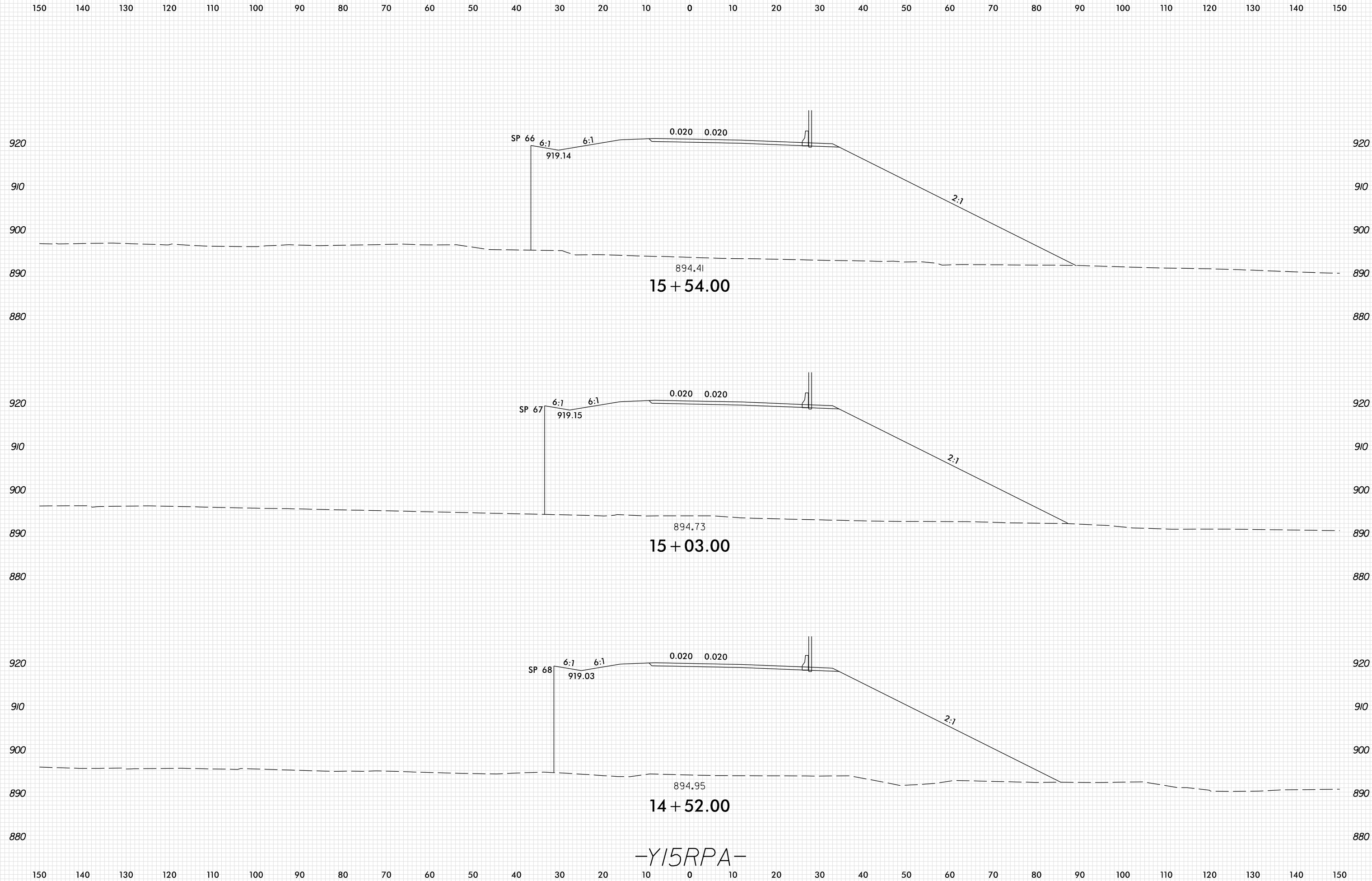

-Y15RPA-

8/23/99

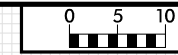

PROJ. REFERENCE NO.	SHEET NO.
U-2579AB	X-518

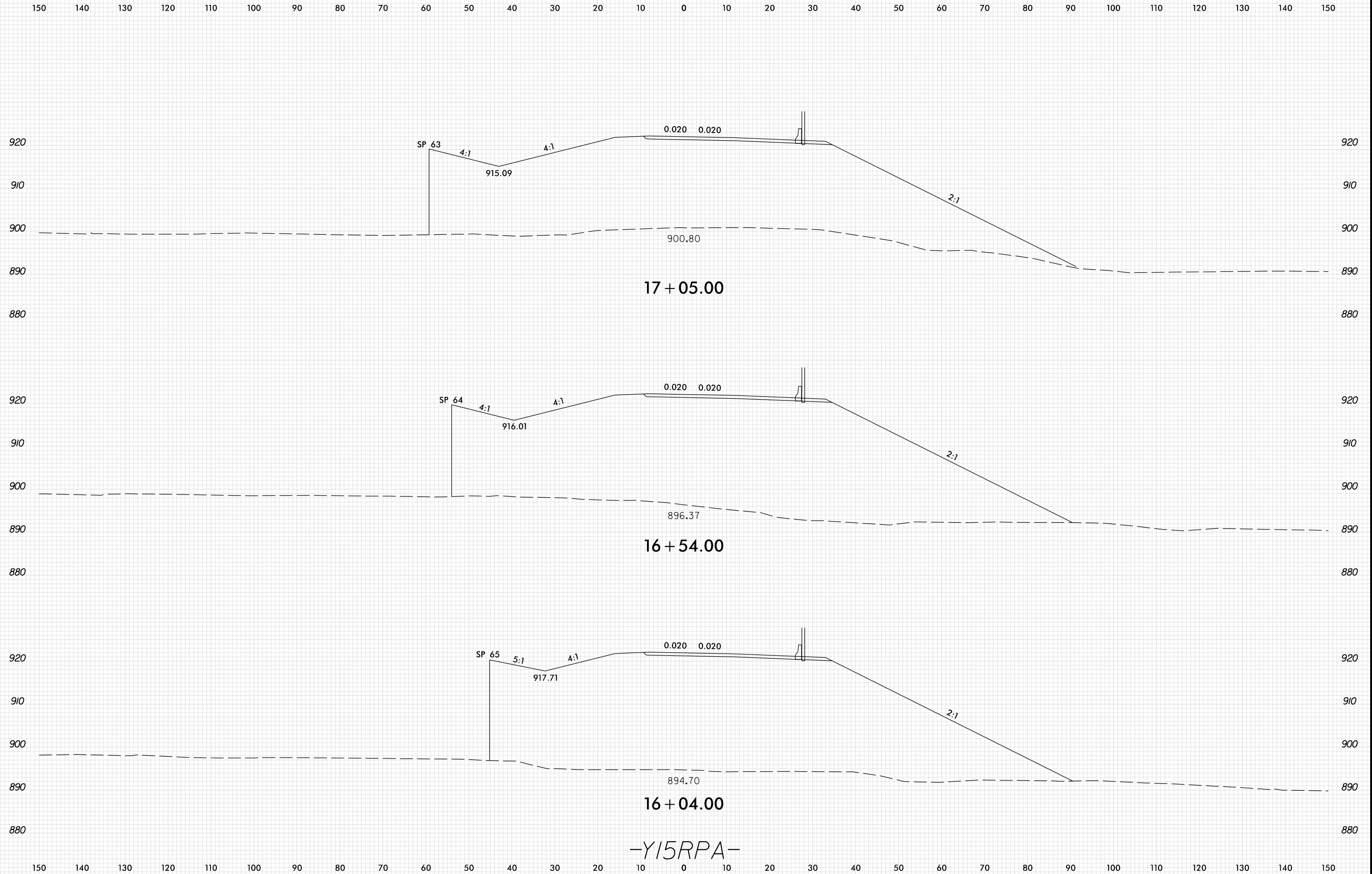

-Y15RPA-

PLOT DRIVER: NCDOT\_pdf\_color\_eng\_100.plt  
 USER: SPEREIRA  
 DATE: 6/10/2021  
 TIME: 2:28:22 PM

8/23/99

0 5 10	PROJ. REFERENCE NO.	SHEET NO.
	U-2579AB	X-519

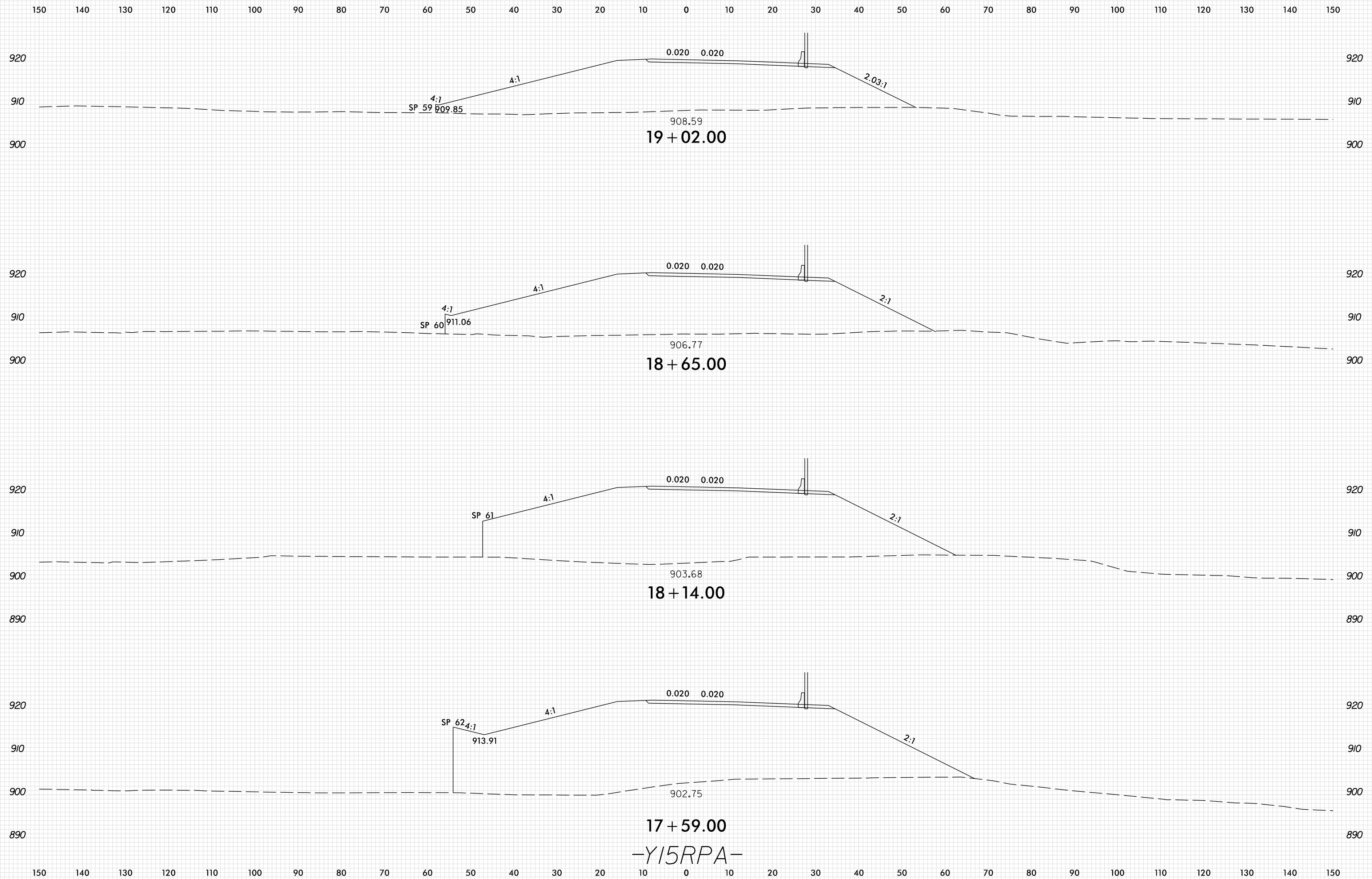

PLOT DRIVER: NCD01\_pdf\_color\_eng\_100.plt  
 USER: SPEREIRA  
 DATE: 6/10/2021  
 TIME: 2:28:22 PM

FILE: \

8/23/99

0 5 10	PROJ. REFERENCE NO.	SHEET NO.
	U-2579AB	X-520

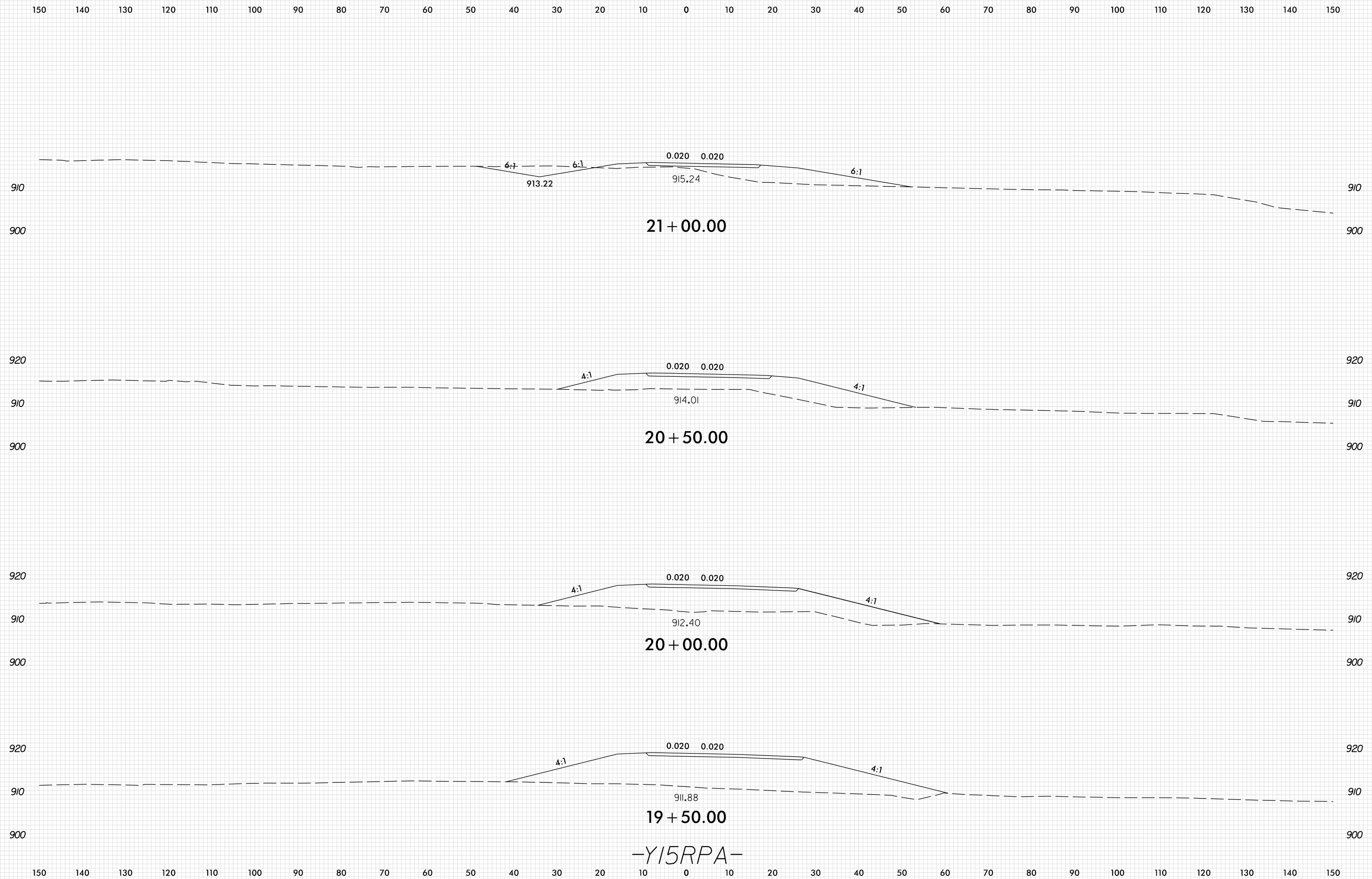

-Y15RPA-

PLOT DRIVER: NCD01\_.pdf\_color\_eng\_100.plt  
 USER: SPEREIRA  
 DATE: 6/10/2021  
 TIME: 2:28:23 PM  
 FILE: \

8/23/99

0 5 10	PROJ. REFERENCE NO.	SHEET NO.
	U-2579AB	X-521

150 140 130 120 110 100 90 80 70 60 50 40 30 20 10 0 10 20 30 40 50 60 70 80 90 100 110 120 130 140 150

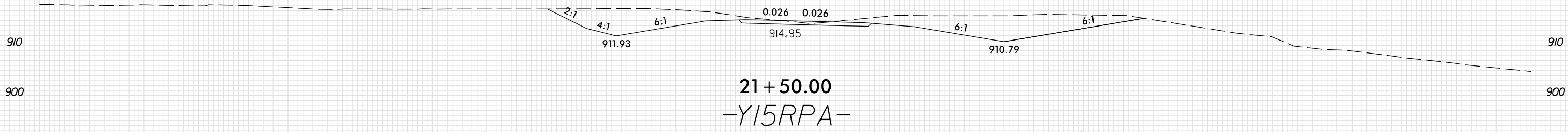
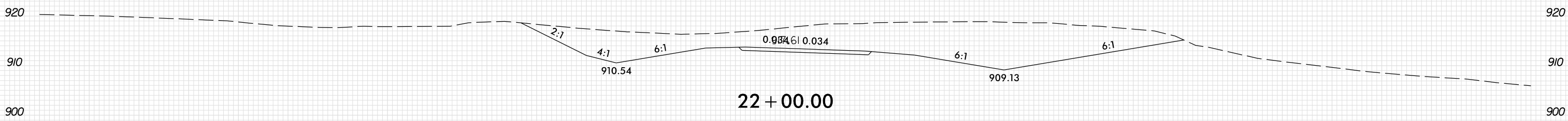
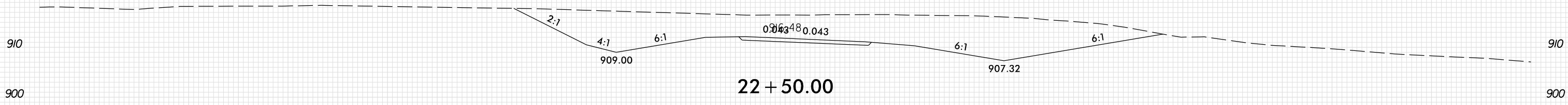
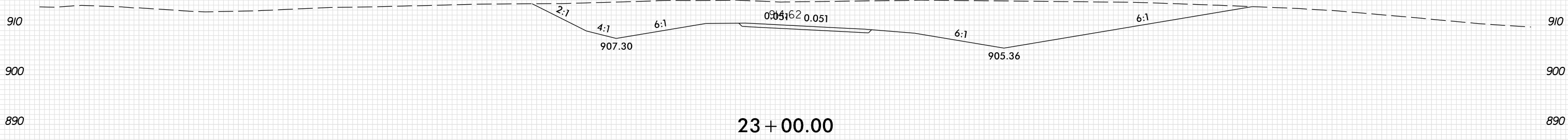

150 140 130 120 110 100 90 80 70 60 50 40 30 20 10 0 10 20 30 40 50 60 70 80 90 100 110 120 130 140 150

PLOT DRIVER: NCD01\_pdf\_color\_eng\_100.plt  
USER: SPEREIRA  
DATE: 6/10/2021  
TIME: 2:28:24 PM  
FILE: \

8/23/99

0 5 10	PROJ. REFERENCE NO.	SHEET NO.
	U-2579AB	X-522

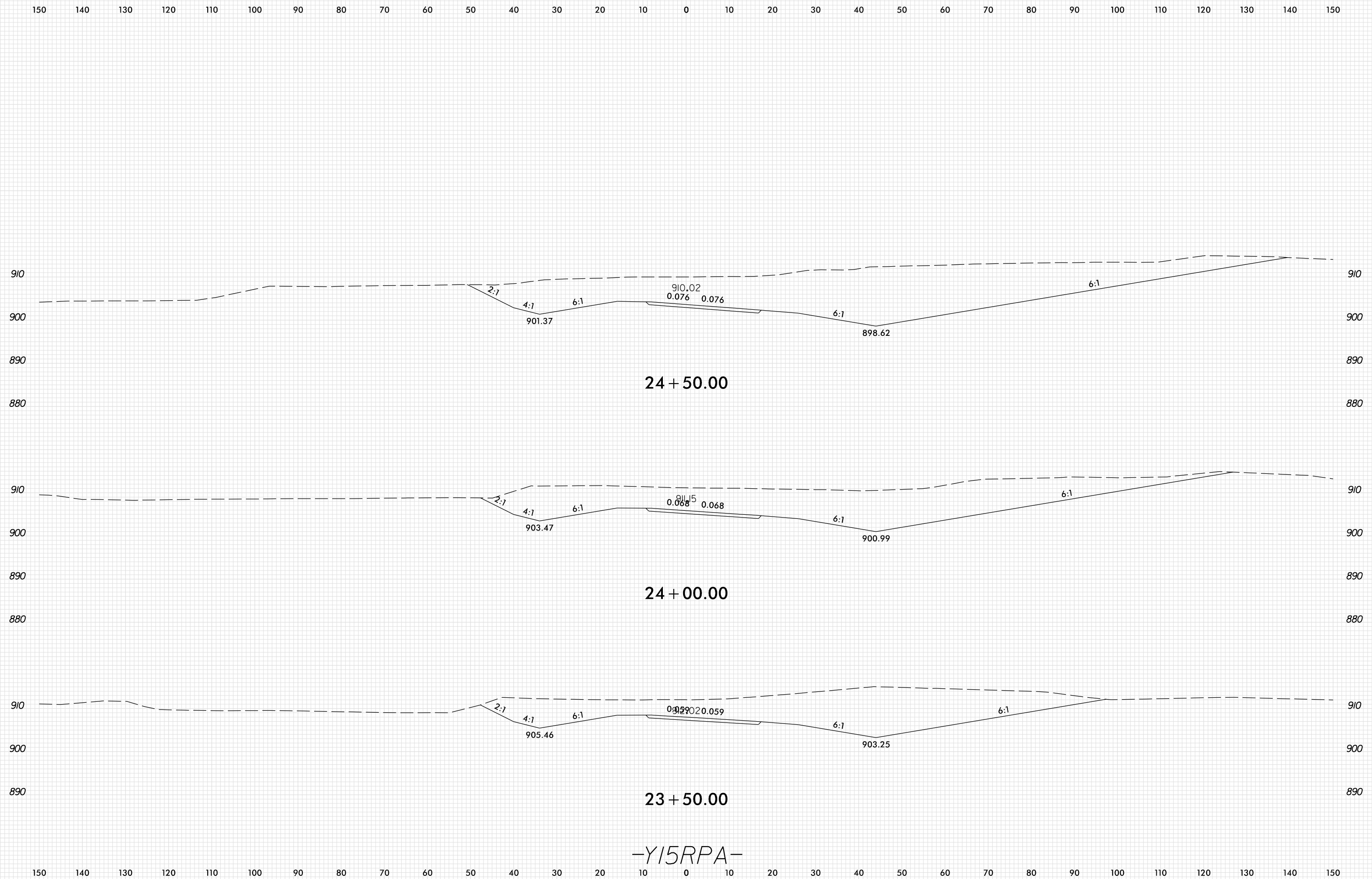

PLOT DRIVER: NCDOT\_pdf\_color\_eng\_100.plt  
 USER: SPEREIRA  
 DATE: 6/10/2021  
 TIME: 2:28:24 PM  
 FILE: \

8/23/99

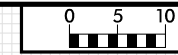

PROJ. REFERENCE NO.	SHEET NO.
U-2579AB	X-523

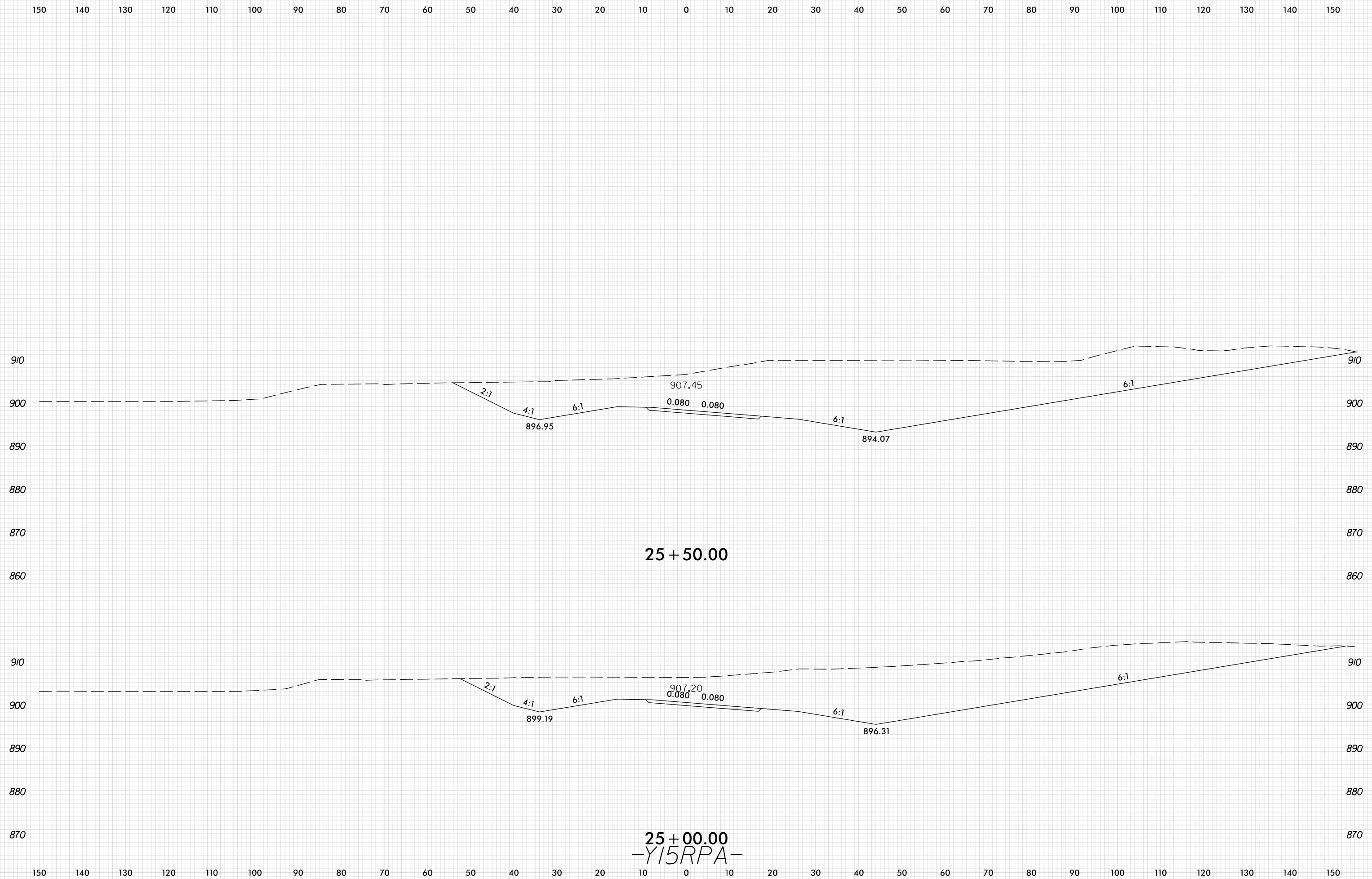

PLOT DRIVER: NCD01\_pdf\_color\_eng\_100.plt  
 USER: SPEREIRA  
 DATE: 6/10/2021  
 TIME: 2:28:25 PM  
 FILE: \

8/23/99

0 5 10	PROJ. REFERENCE NO.	SHEET NO.
	U-2579AB	X-524

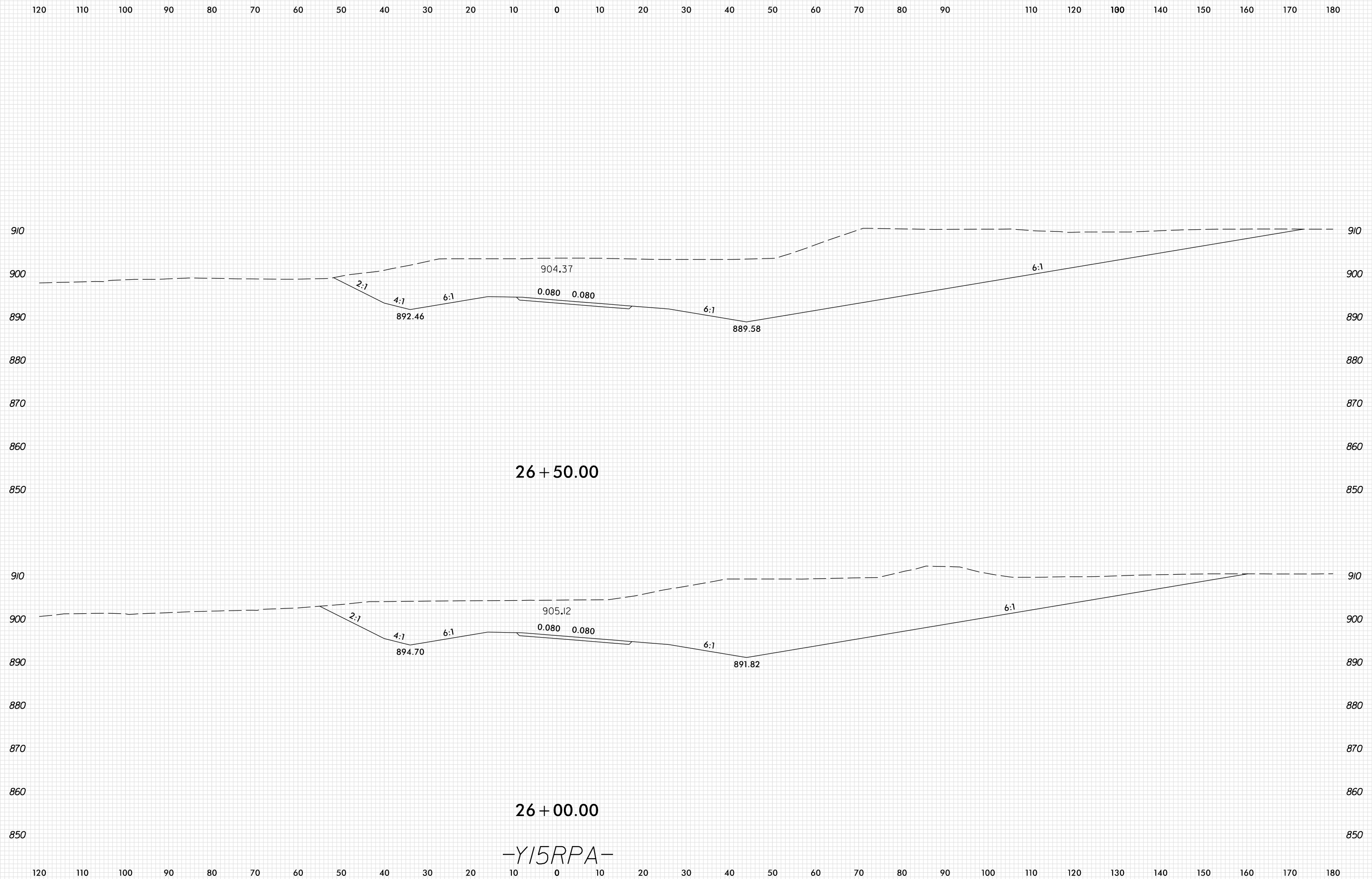

PLOT DRIVER: NCD01\_pdf\_color\_eng\_100.plt  
 USER: SPEREIRA  
 DATE: 6/10/2021  
 TIME: 2:28:25 PM  
 FILE: \

26 + 00.00

26 + 50.00

-Y15RPA-



8/23/99



PROJ. REFERENCE NO.	SHEET NO.
U-2579AB	X-525

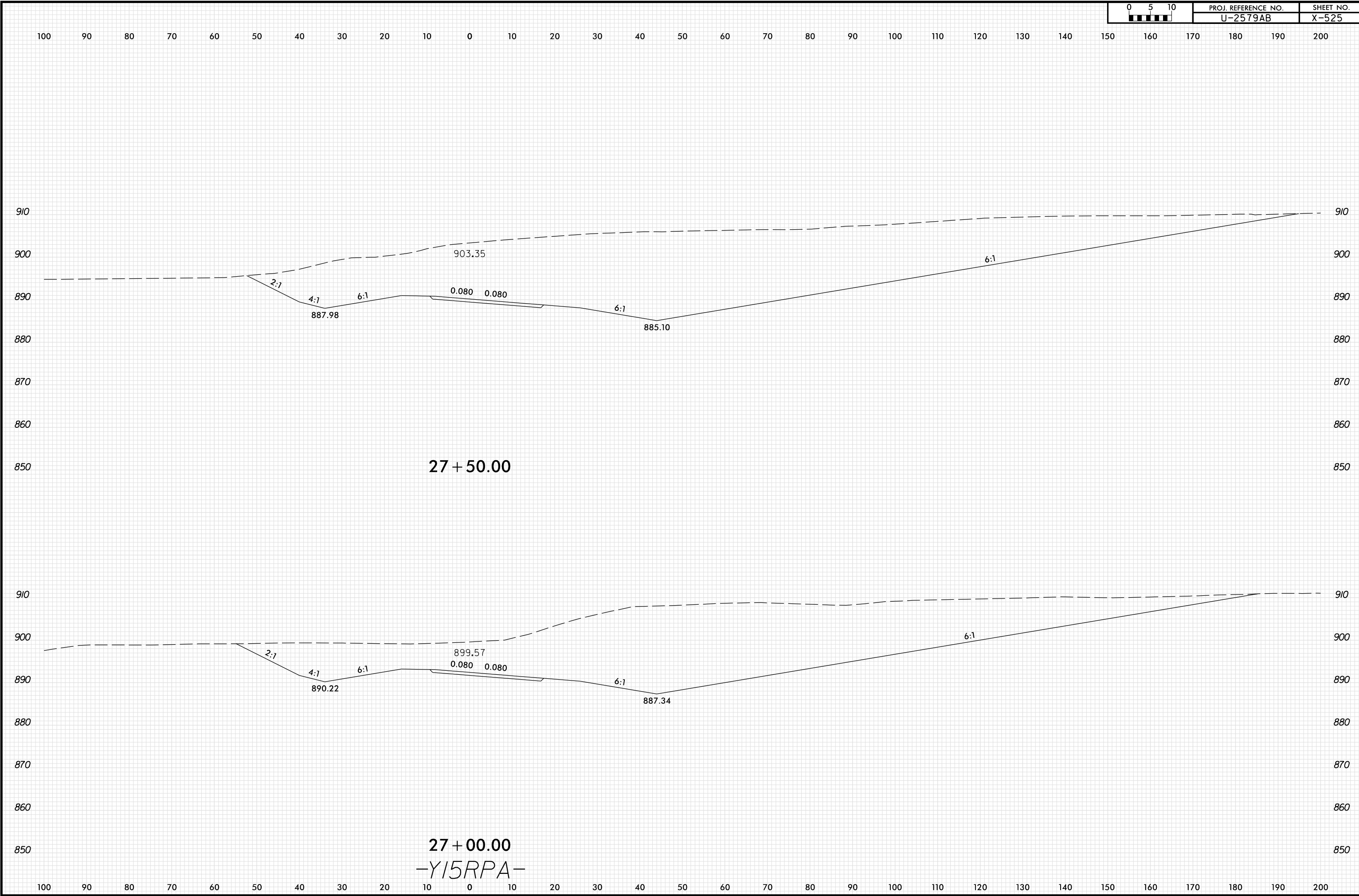

PLOT DRIVER: NCD01\_pdf\_color\_eng\_100.plt  
 USER: SPEREIRA  
 DATE: 6/10/2021  
 TIME: 2:28:26 PM  
 FILE: \

8/23/99

0 5 10	PROJ. REFERENCE NO.	SHEET NO.
	U-2579AB	X-526

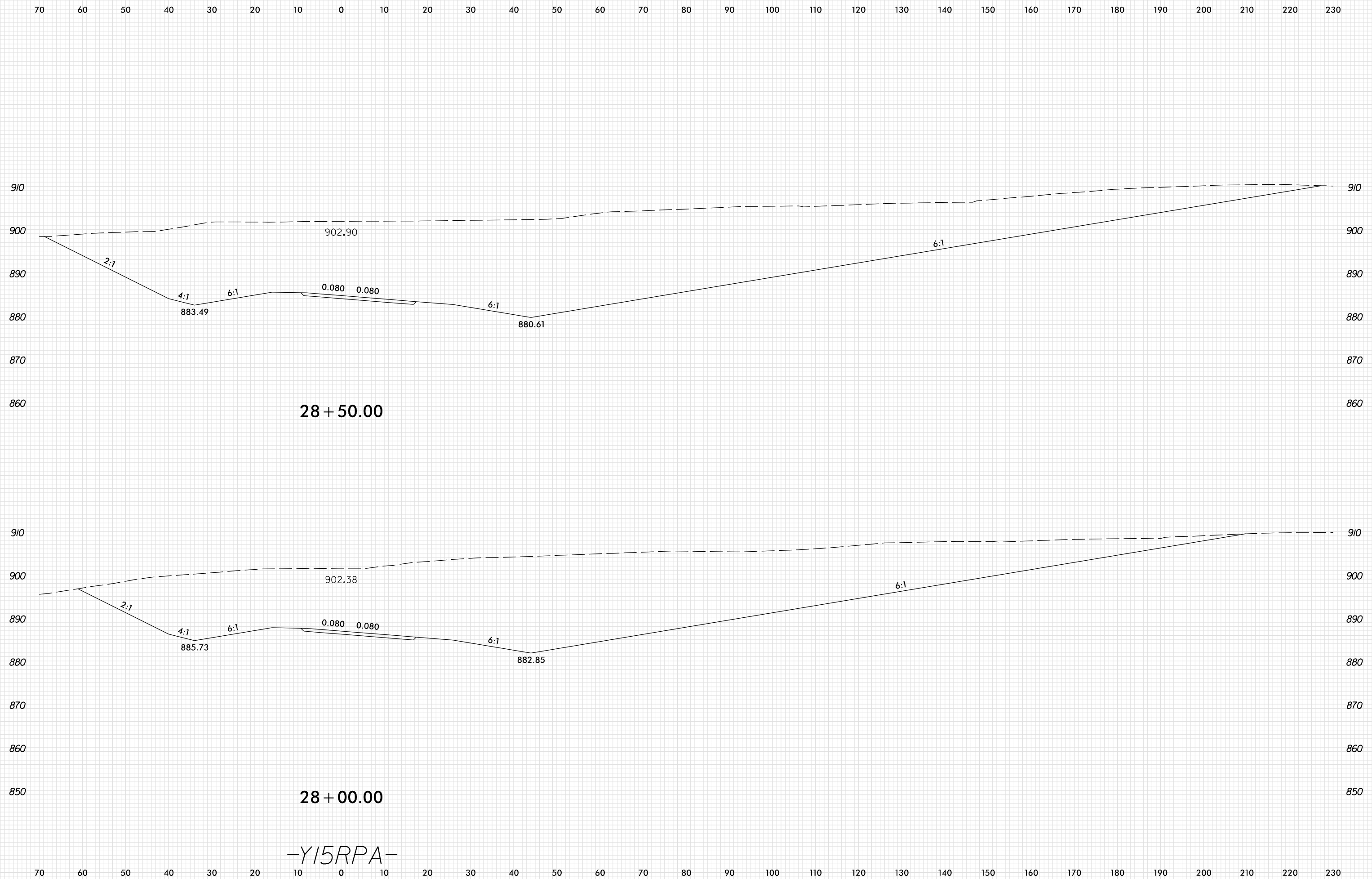

PLOT DRIVER: NCDOT\_pdf\_color\_eng\_100.plt  
 USER: SPEREIRA  
 DATE: 6/10/2021  
 TIME: 2:28:27 PM  
 FILE: \

8/23/99



PROJ. REFERENCE NO.	SHEET NO.
U-2579AB	X-527

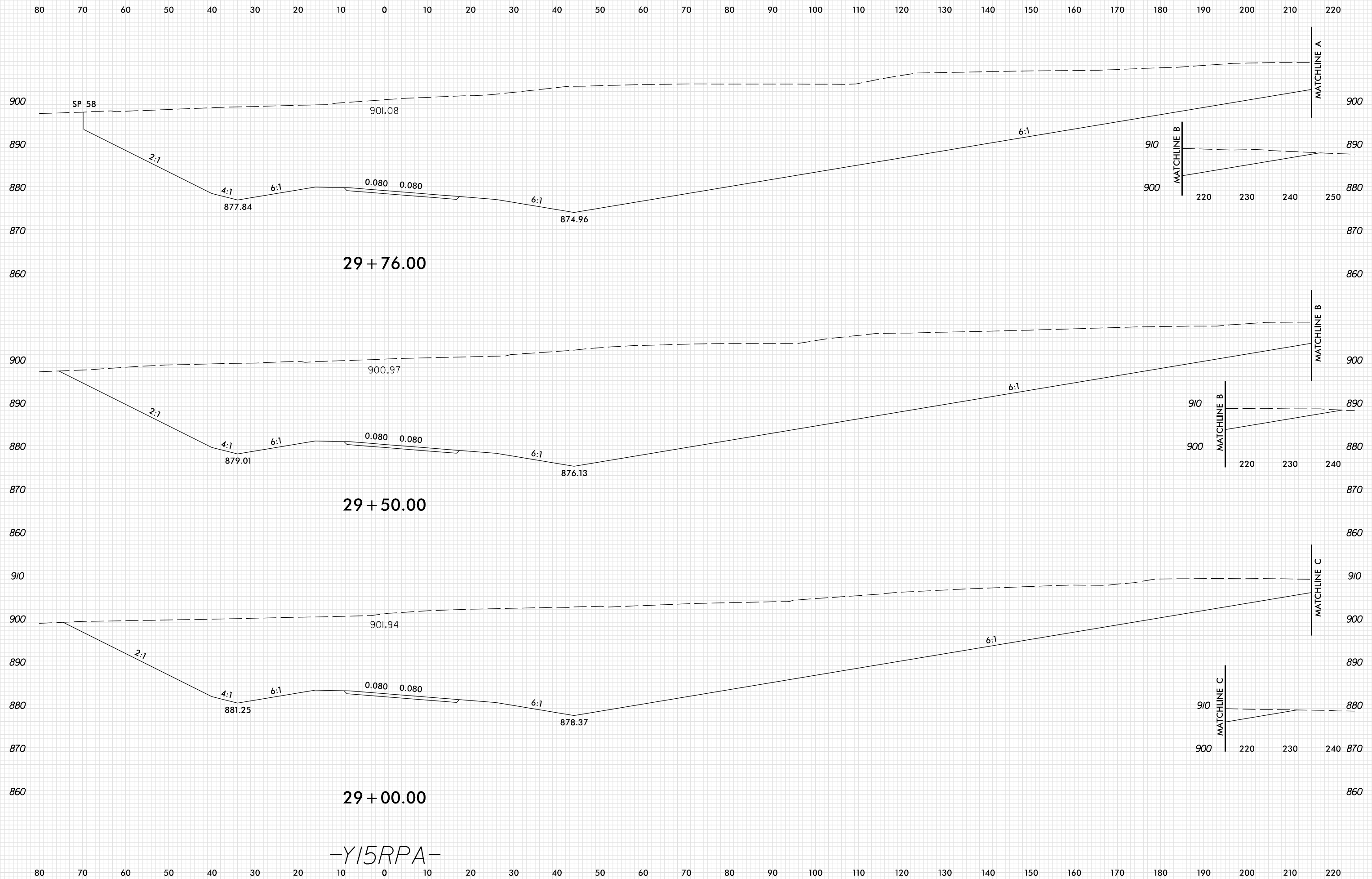

PLOT DRIVER: NCD01\_pdf\_color\_eng\_100.plt  
 USER: SPEREIRA  
 DATE: 6/10/2021  
 TIME: 2:28:27 PM

8/23/99

60 50 40 30 20 10 0 10 20 30 40 50 60 70 80 90 100 110 120 130 140 150 160 170 180 190 200 210 220 230 240

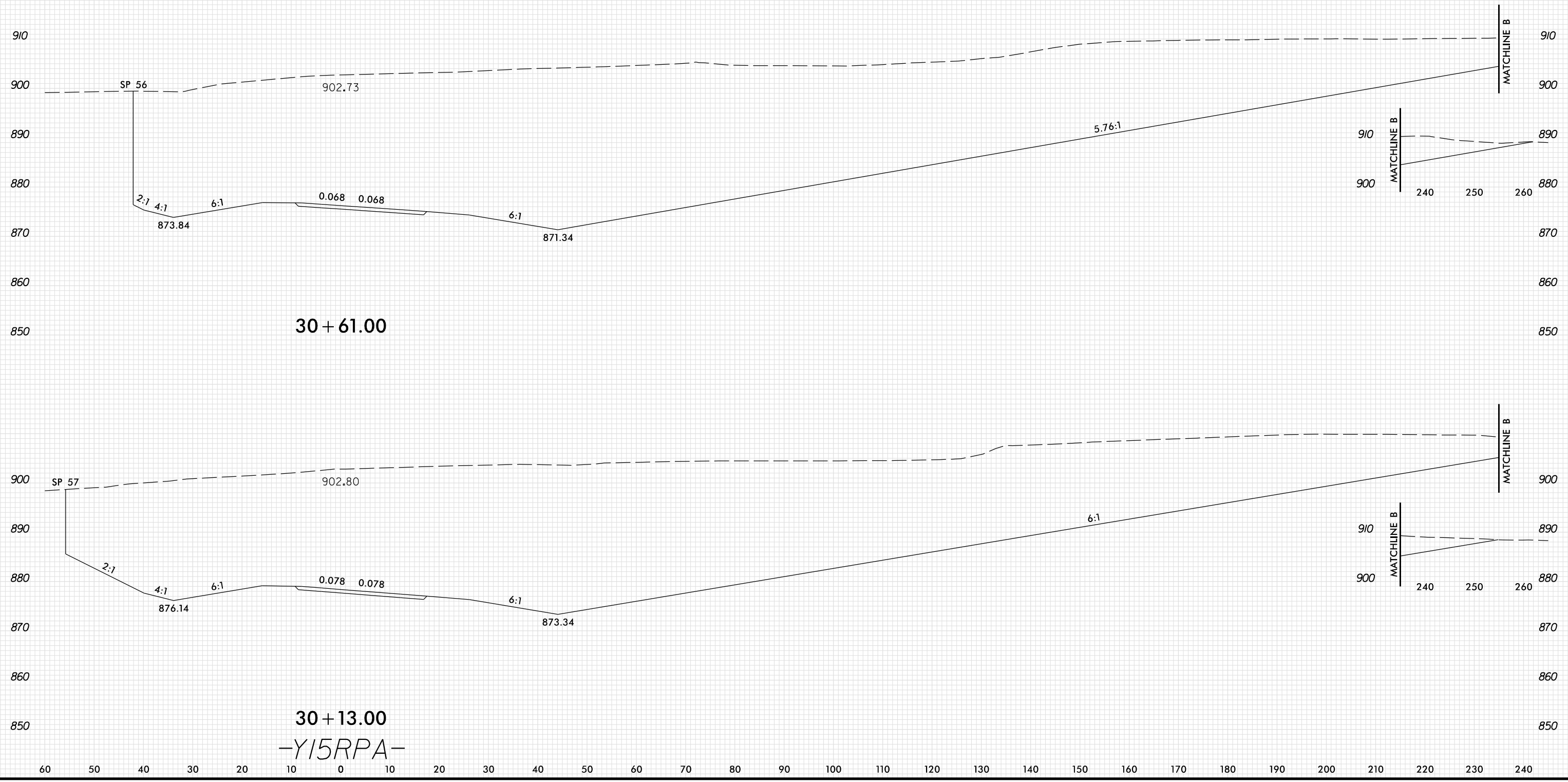

PLOT DRIVER: NCDOT\_pdf\_color\_eng\_100.plt  
 USER: SPEREIRA  
 DATE: 6/10/2021  
 TIME: 2:28:28 PM  
 FILE: \

30+61.00

30+13.00

-Y15RPA-

8/23/99

0 5 10	PROJ. REFERENCE NO.	SHEET NO.
	U-2579AB	X-529

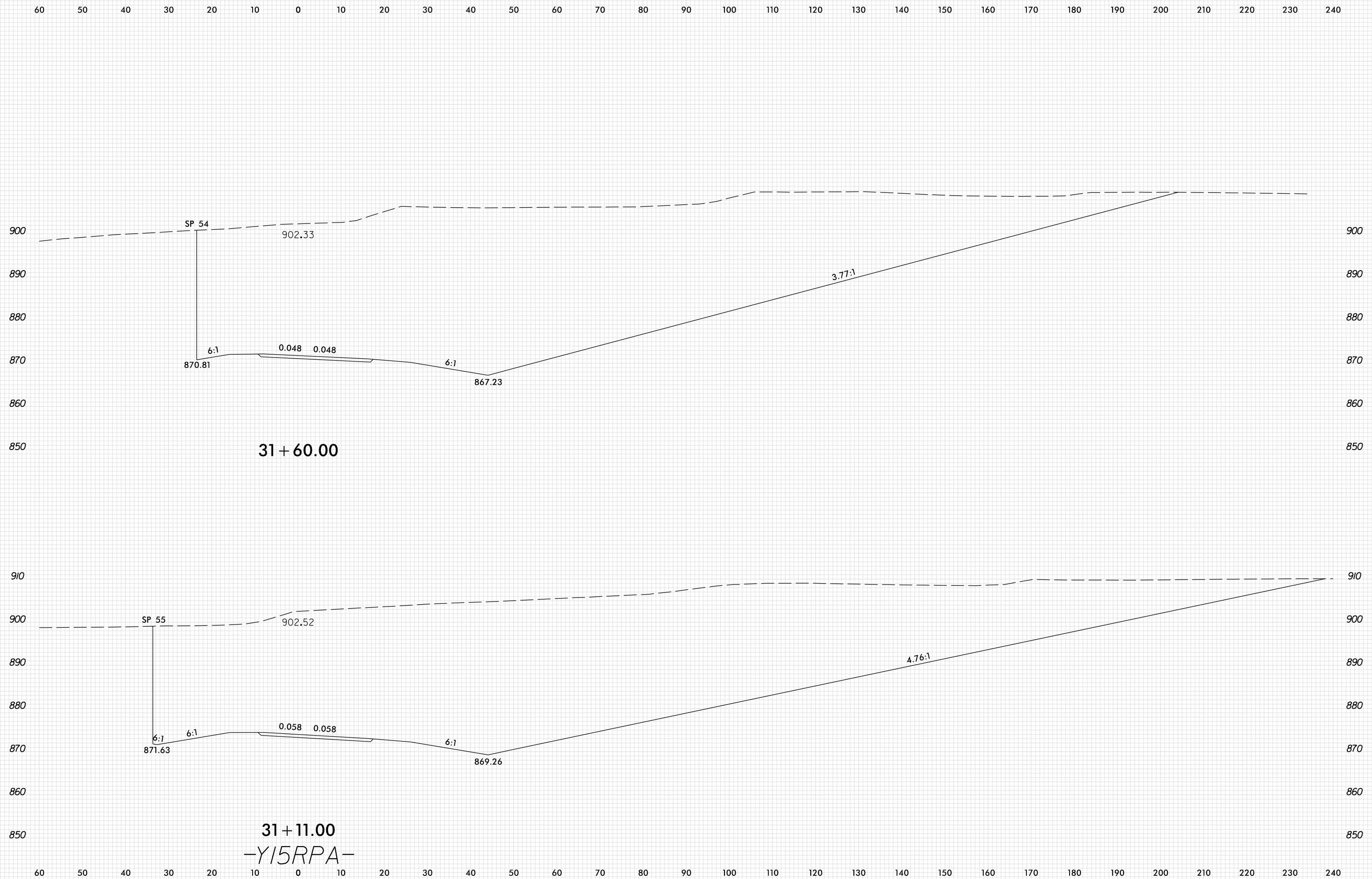

PLOT DRIVER: NCDOT\_pdf\_color\_eng\_100.plt  
 USER: SPEREIRA  
 DATE: 6/10/2021  
 TIME: 2:28:29 PM  
 FILE: \

8/23/99

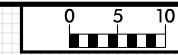

PROJ. REFERENCE NO.	SHEET NO.
U-2579AB	X-530

130 120 110 100 90 80 70 60 50 40 30 20 10 0 10 20 30 40 50 60 70 80 90 100 110 120 130 140 150 160 170

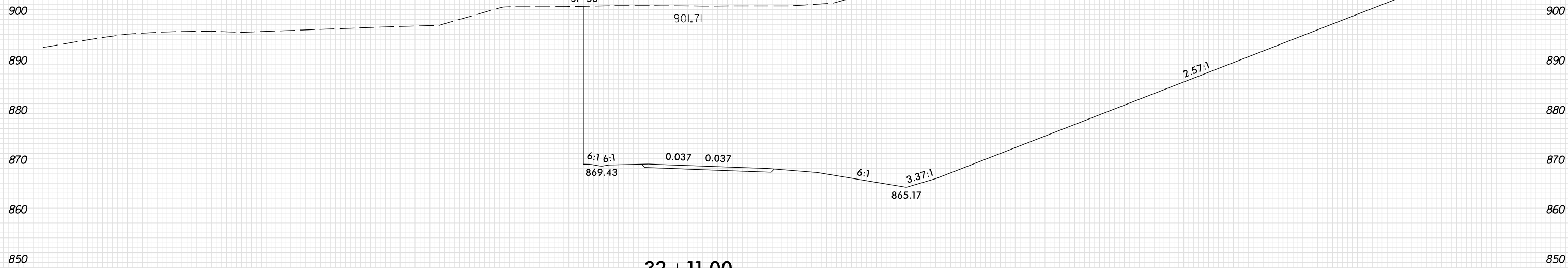

32 + 11.00

-Y15RPA-

130 120 110 100 90 80 70 60 50 40 30 20 10 0 10 20 30 40 50 60 70 80 90 100 110 120 130 140 150 160 170

PLOT DRIVER: NCD01...pdf\_color\_eng\_100.plt  
 USER: SPEREIRA  
 DATE: 6/10/2021  
 TIME: 2:28:29 PM  
 FILE: \

8/23/99

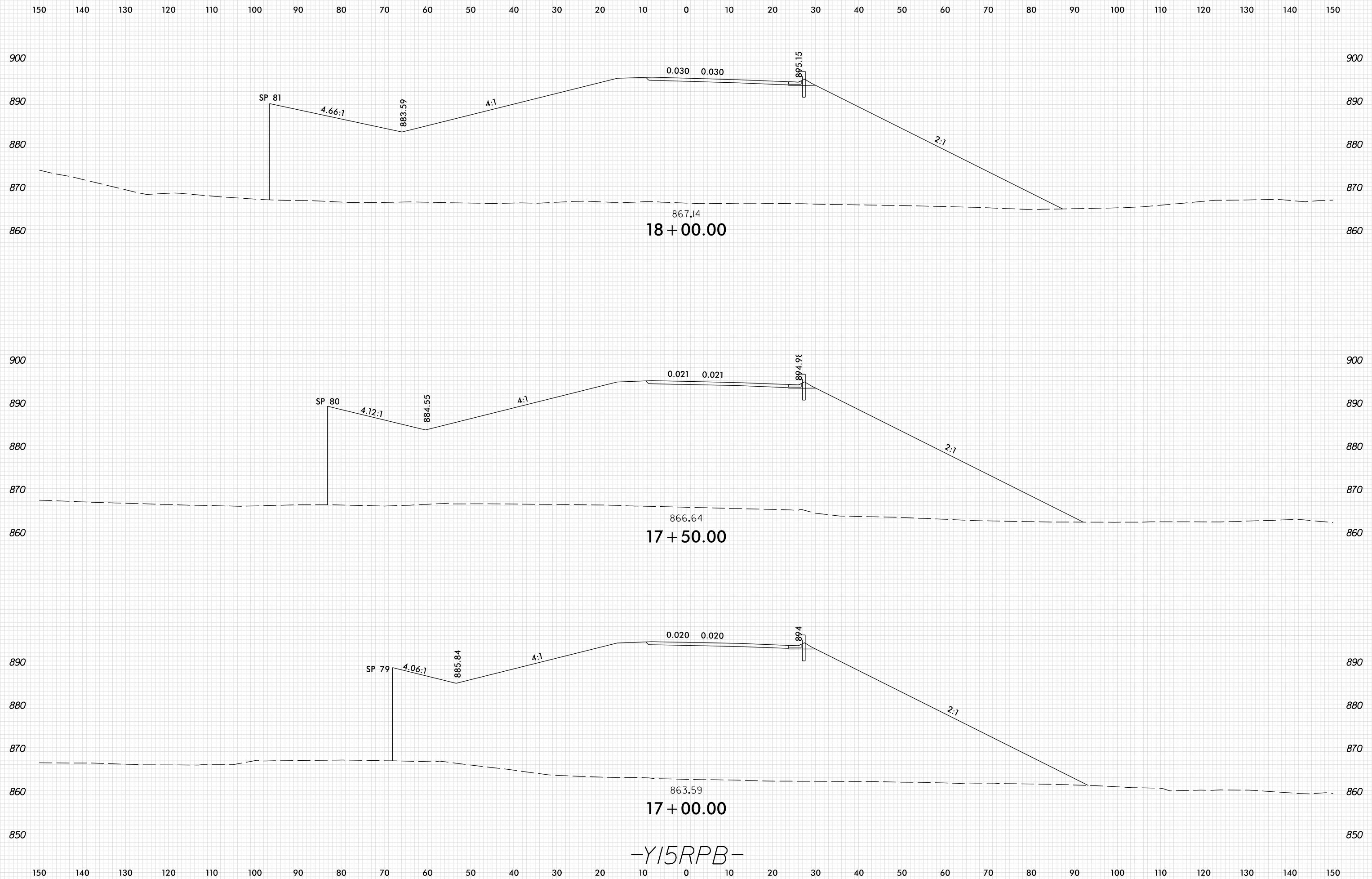

-Y15RPB-

PLOT DRIVER: NCDOT\_pdf\_color\_eng\_100.plt  
 USER: SPEREIRA  
 DATE: 6/10/2021  
 TIME: 2:28:39 PM  
 FILE: \

8/23/99

0 5 10	PROJ. REFERENCE NO.	SHEET NO.
	U-2579AB	X-532

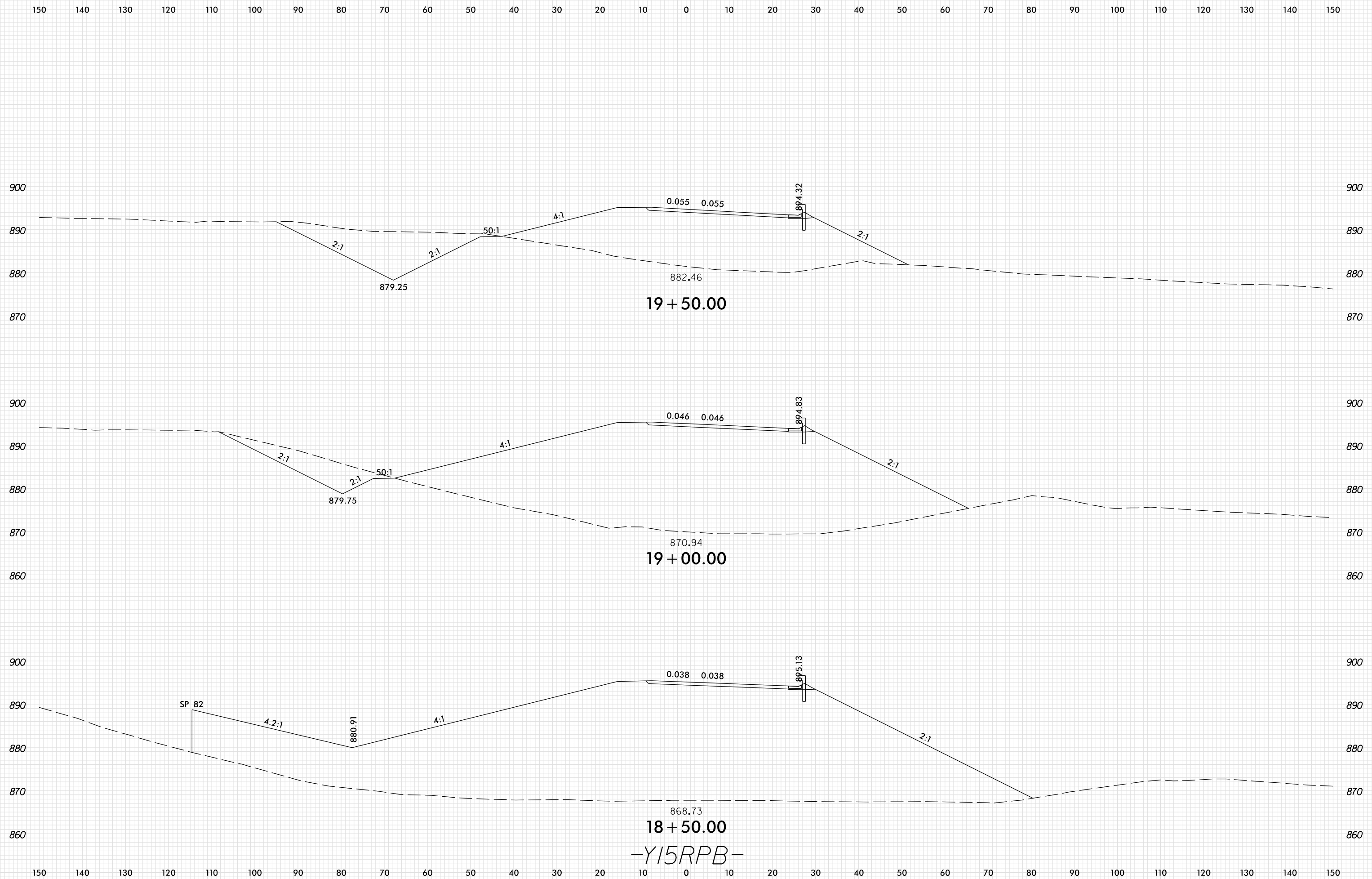

PLOT DRIVER: NCDOT\_pdf\_color\_eng\_100.plt  
 USER: SPEREIRA  
 DATE: 6/10/2021  
 TIME: 2:28:40 PM  
 FILE: \

-Y15RPB-



8/23/99

0 5 10	PROJ. REFERENCE NO.	SHEET NO.
	U-2579AB	X-533

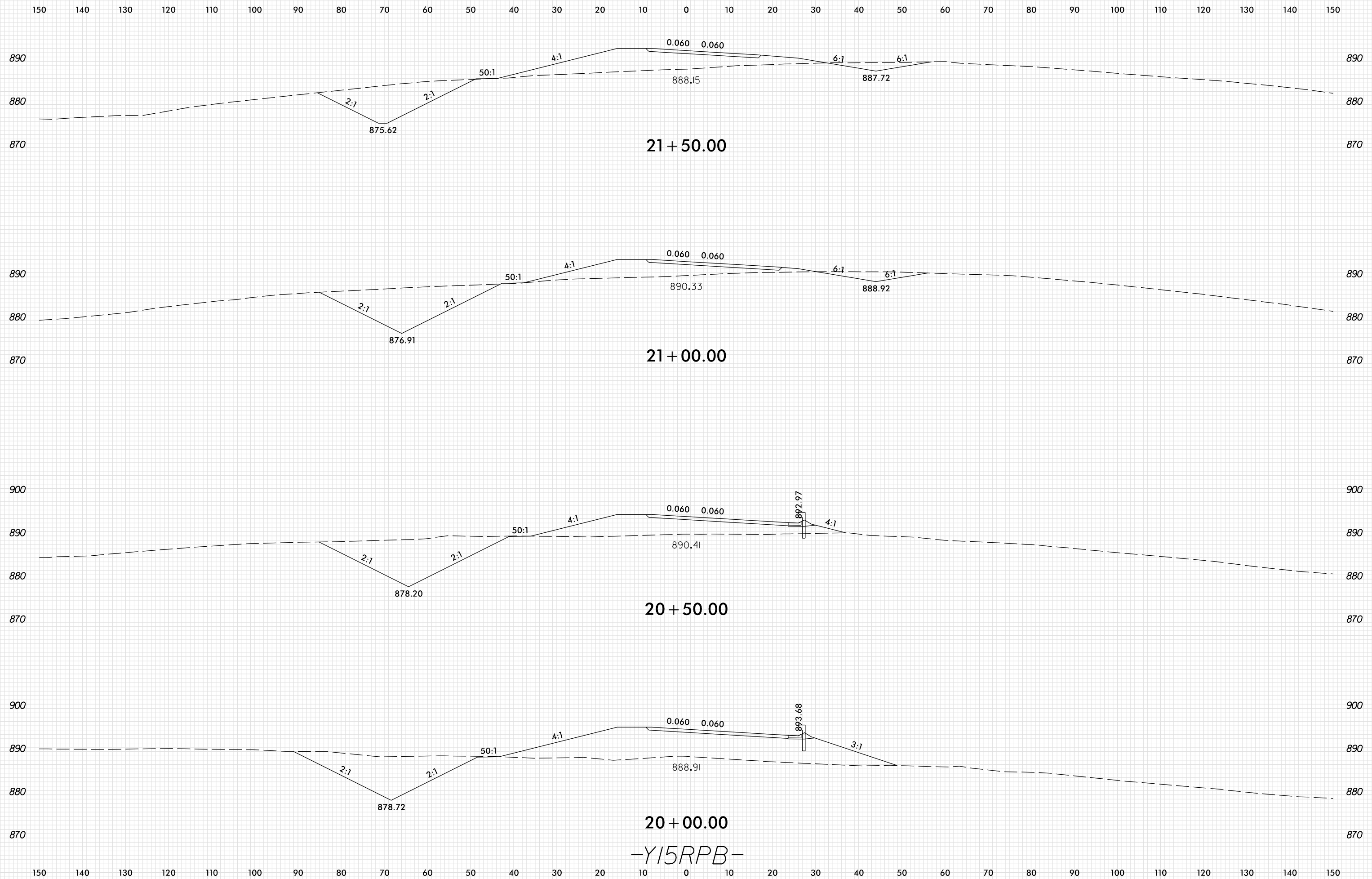

PLOT DRIVER: NCD01\_pdf\_color\_eng\_100.plt  
 USER: SPEREIRA  
 DATE: 6/10/2021  
 TIME: 2:28:40 PM  
 FILE: \

8/23/99

0 5 10	PROJ. REFERENCE NO.	SHEET NO.
	U-2579AB	X-534

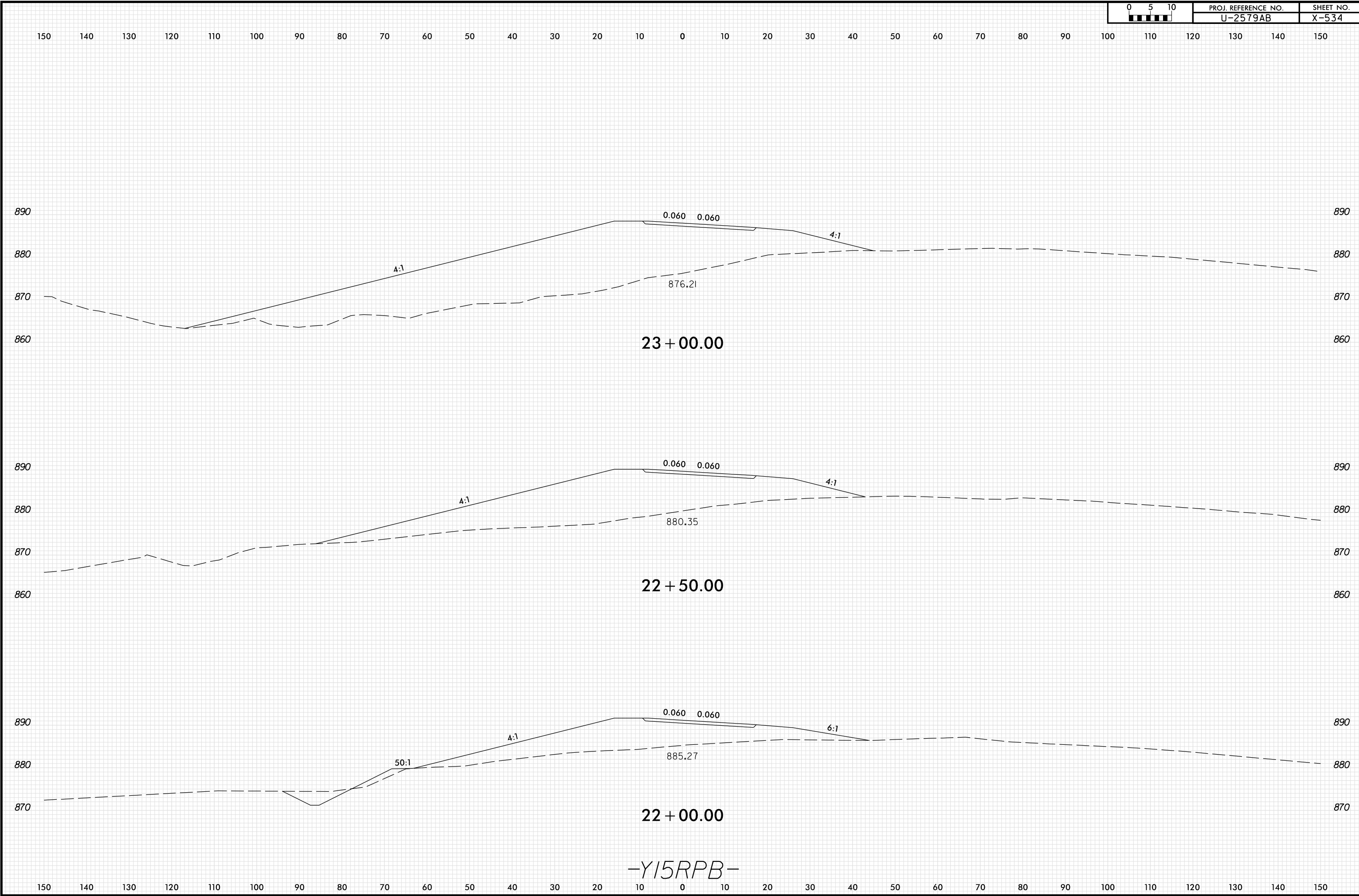

PLOT DRIVER: NCDOT\_pdf\_color\_eng\_100.plt  
 USER: SPEREIRA  
 DATE: 6/10/2021  
 TIME: 2:28:41 PM  
 FILE: \

8/23/99

0 5 10	PROJ. REFERENCE NO.	SHEET NO.
	U-2579AB	X-535

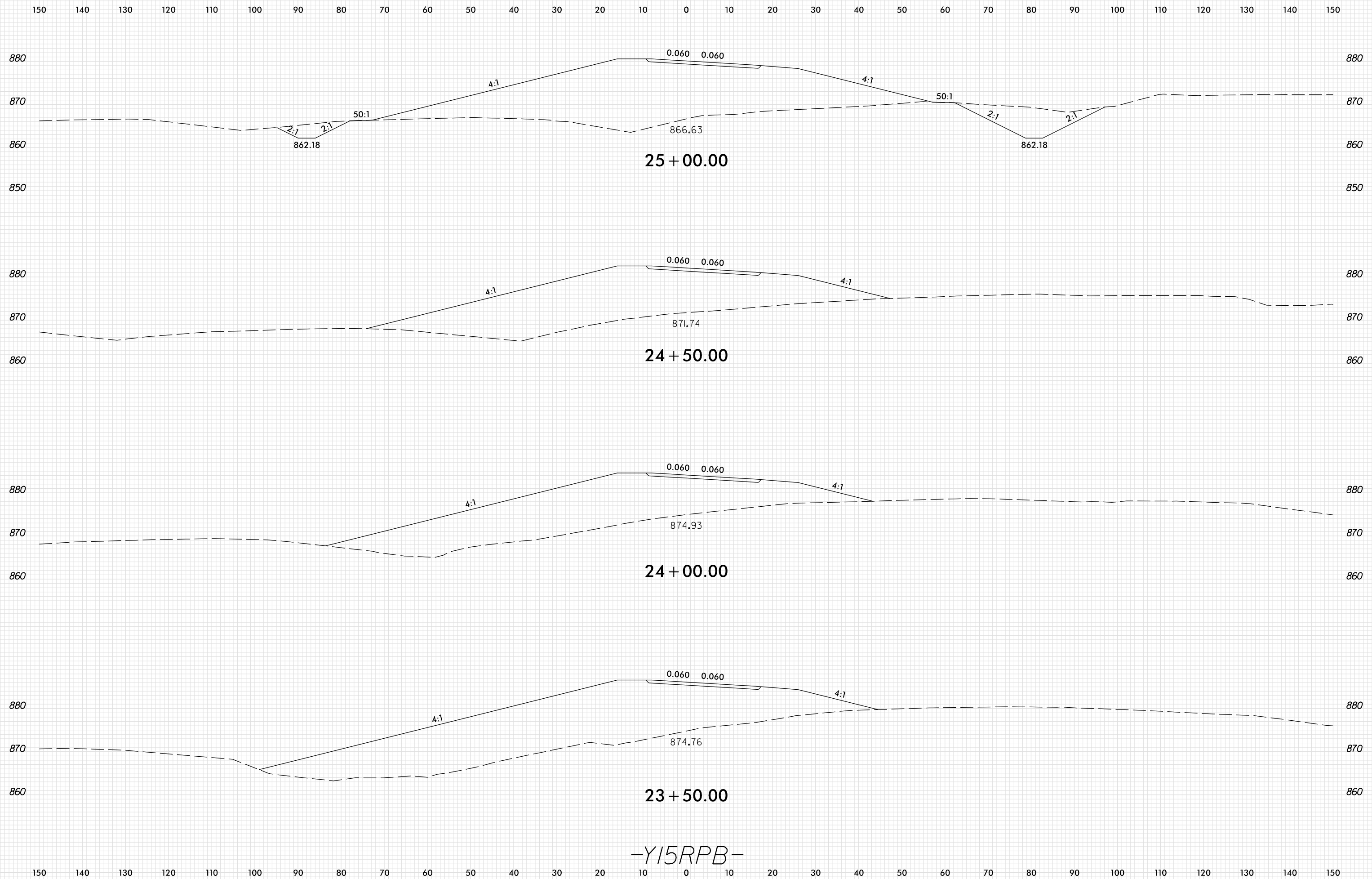

PLOT DRIVER: NCD01\_pdf\_color\_eng\_100.plt  
 USER: SPEREIRA  
 DATE: 6/10/2021  
 TIME: 2:28:41 PM  
 FILE: \

-Y15RPB-

8/23/99



PROJ. REFERENCE NO.	SHEET NO.
U-2579AB	X-536

150 140 130 120 110 100 90 80 70 60 50 40 30 20 10 0 10 20 30 40 50 60 70 80 90 100 110 120 130 140 150

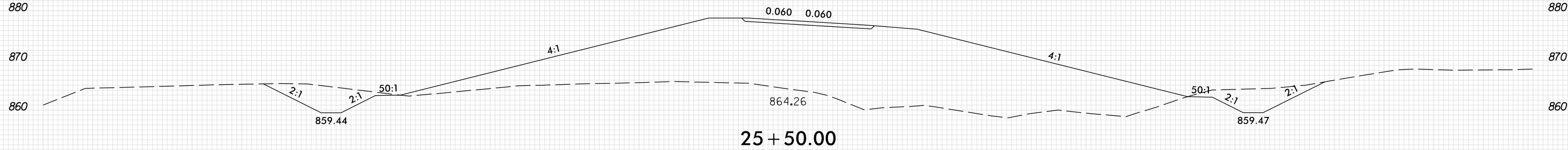
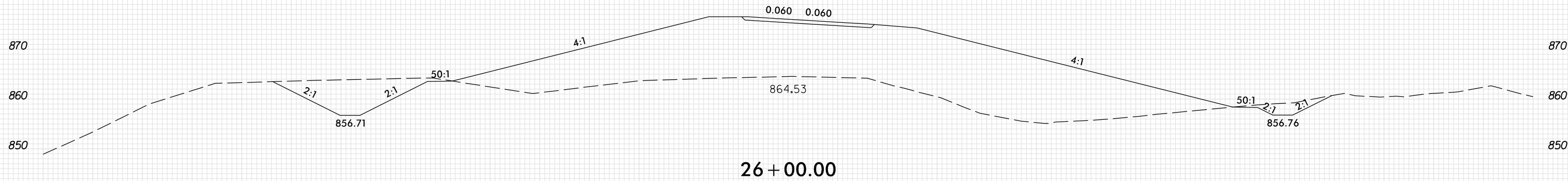
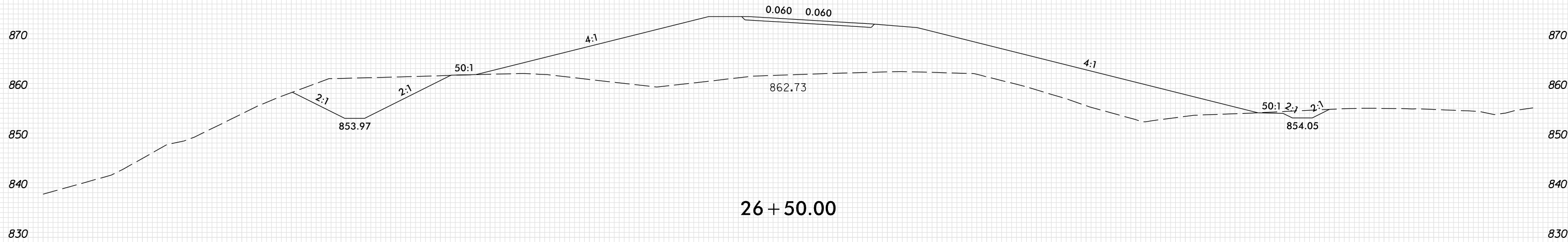

-Y15RPB-

PLOT DRIVER: NCD01\_pdf\_color\_eng\_100.plt  
 USER: SPEREIRA  
 DATE: 6/10/2021  
 TIME: 2:28:42 PM

8/23/99

0 5 10	PROJ. REFERENCE NO.	SHEET NO.
	U-2579AB	X-537

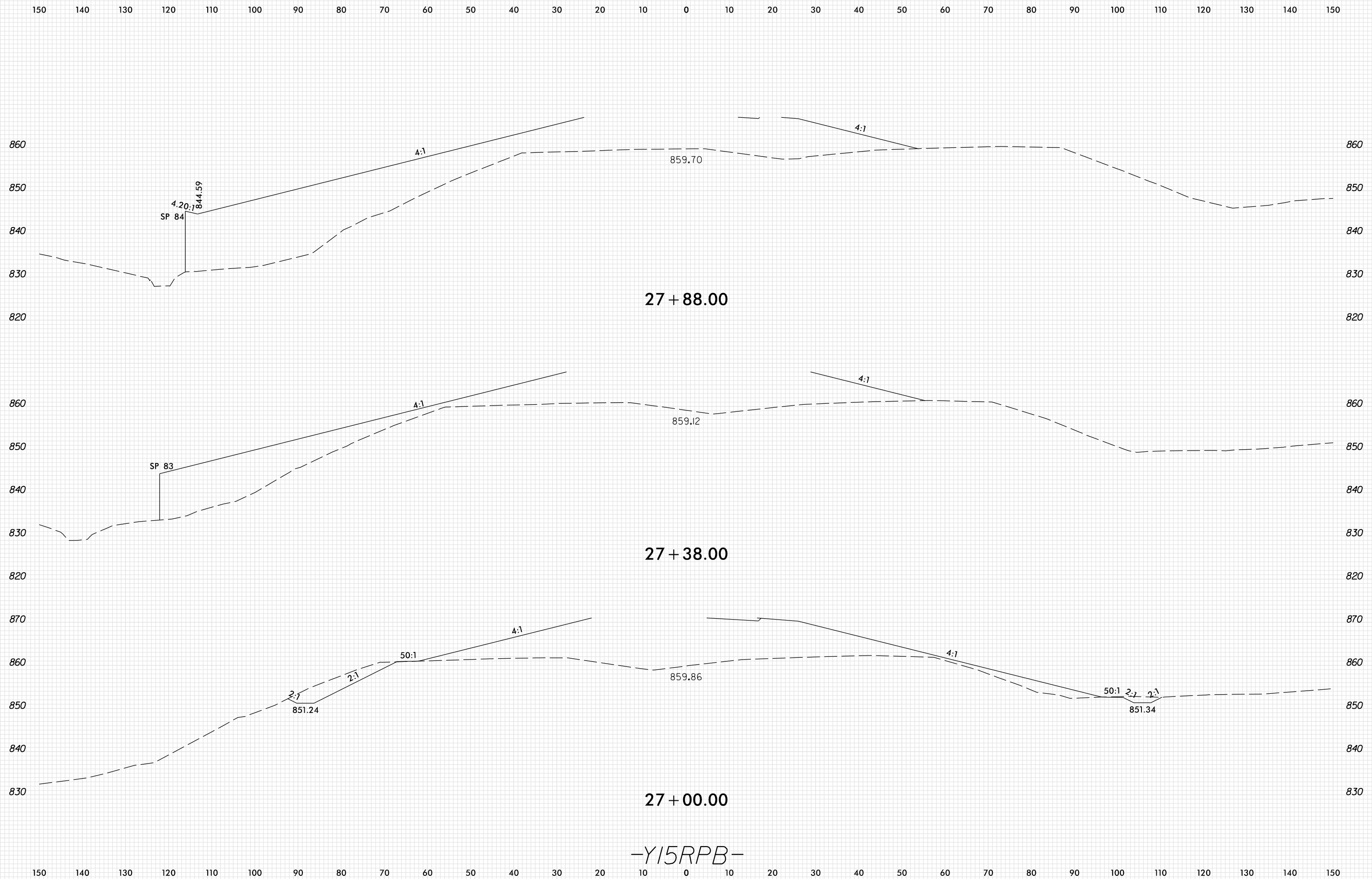

PLOT DRIVER: NCDOT\_pdf\_color\_eng\_100.plt  
 USER: SPEREIRA  
 DATE: 6/10/2021  
 TIME: 2:28:43 PM  
 FILE: \

-Y15RPB-

8/23/99

0 5 10	PROJ. REFERENCE NO.	SHEET NO.
	U-2579AB	X-538

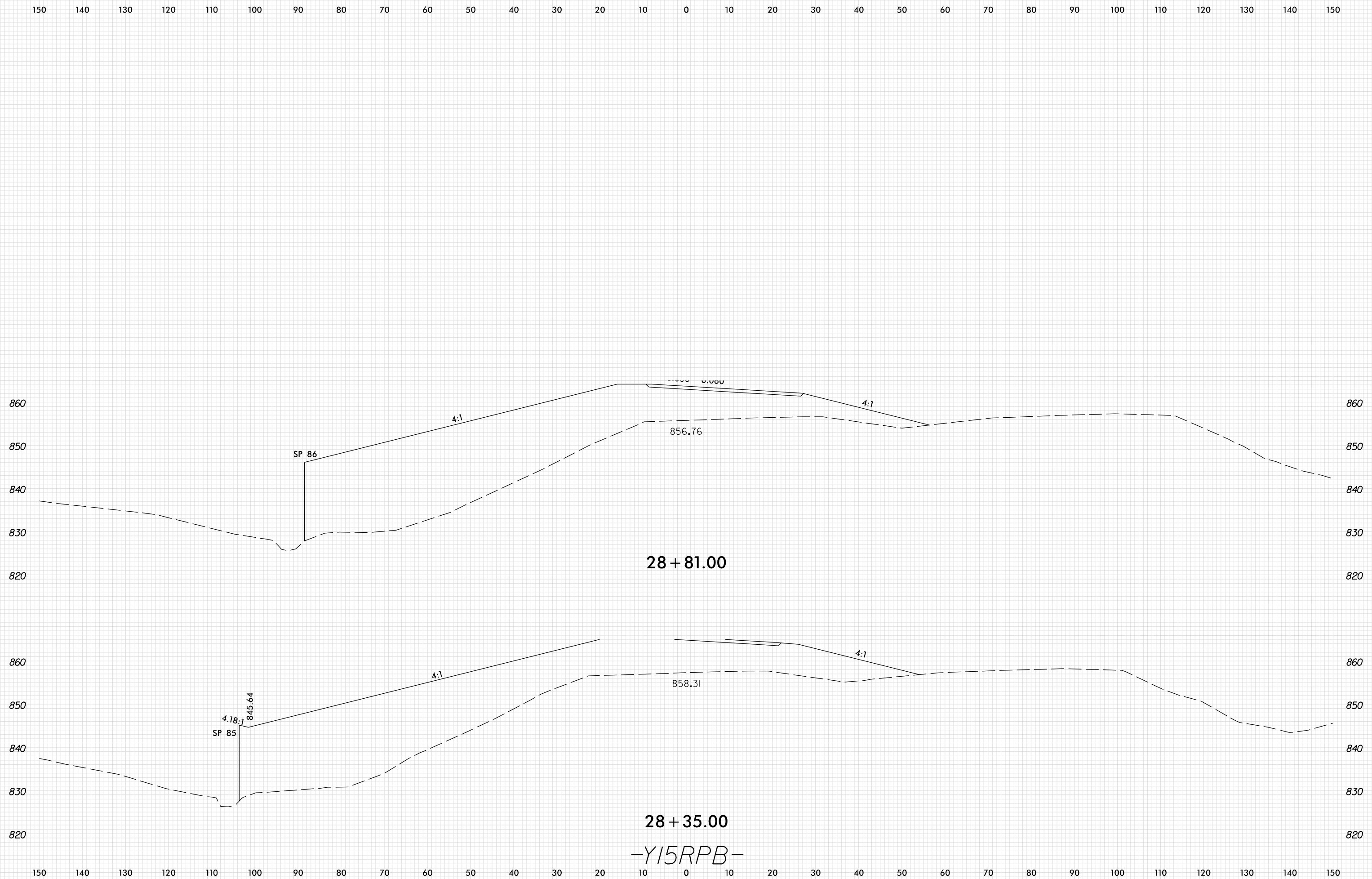

PLOT DRIVER: NCDOT\_pdf\_color\_eng\_100.plt  
 USER: SPEREIRA  
 DATE: 6/10/2021  
 TIME: 2:28:44 PM  
 FILE: \

8/23/99

150 140 130 120 110 100 90 80 70 60 50 40 30 20 10 0 10 20 30 40 50 60 70 80 90 100 110 120 130 140 150

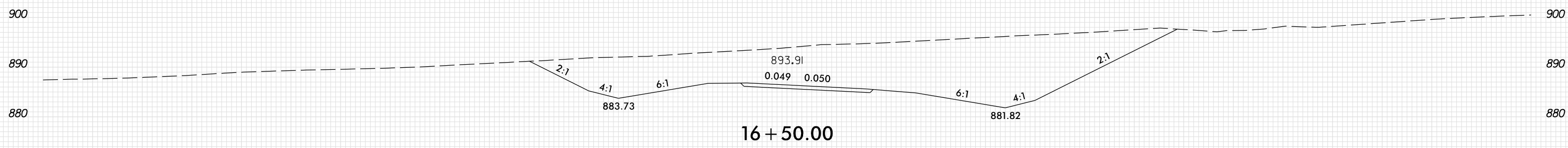
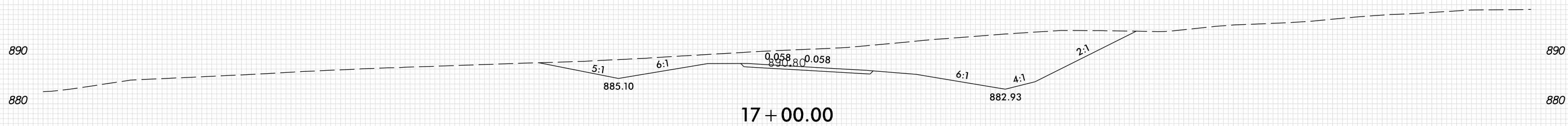
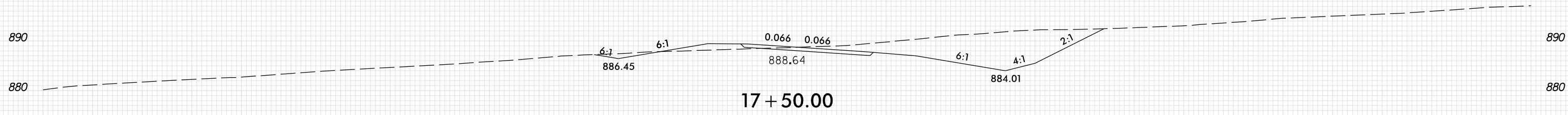
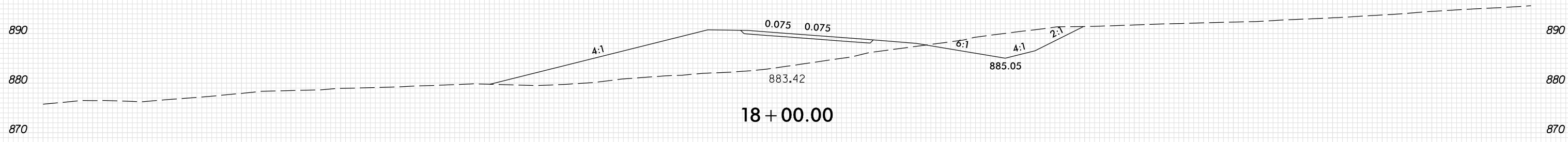

-Y15RPC-

150 140 130 120 110 100 90 80 70 60 50 40 30 20 10 0 10 20 30 40 50 60 70 80 90 100 110 120 130 140 150

PLOT DRIVER: NCD01\_pdf\_color\_eng\_100.plt  
USER: SPEREIRA  
DATE: 6/10/2021  
TIME: 2:28:53 PM

8/23/99

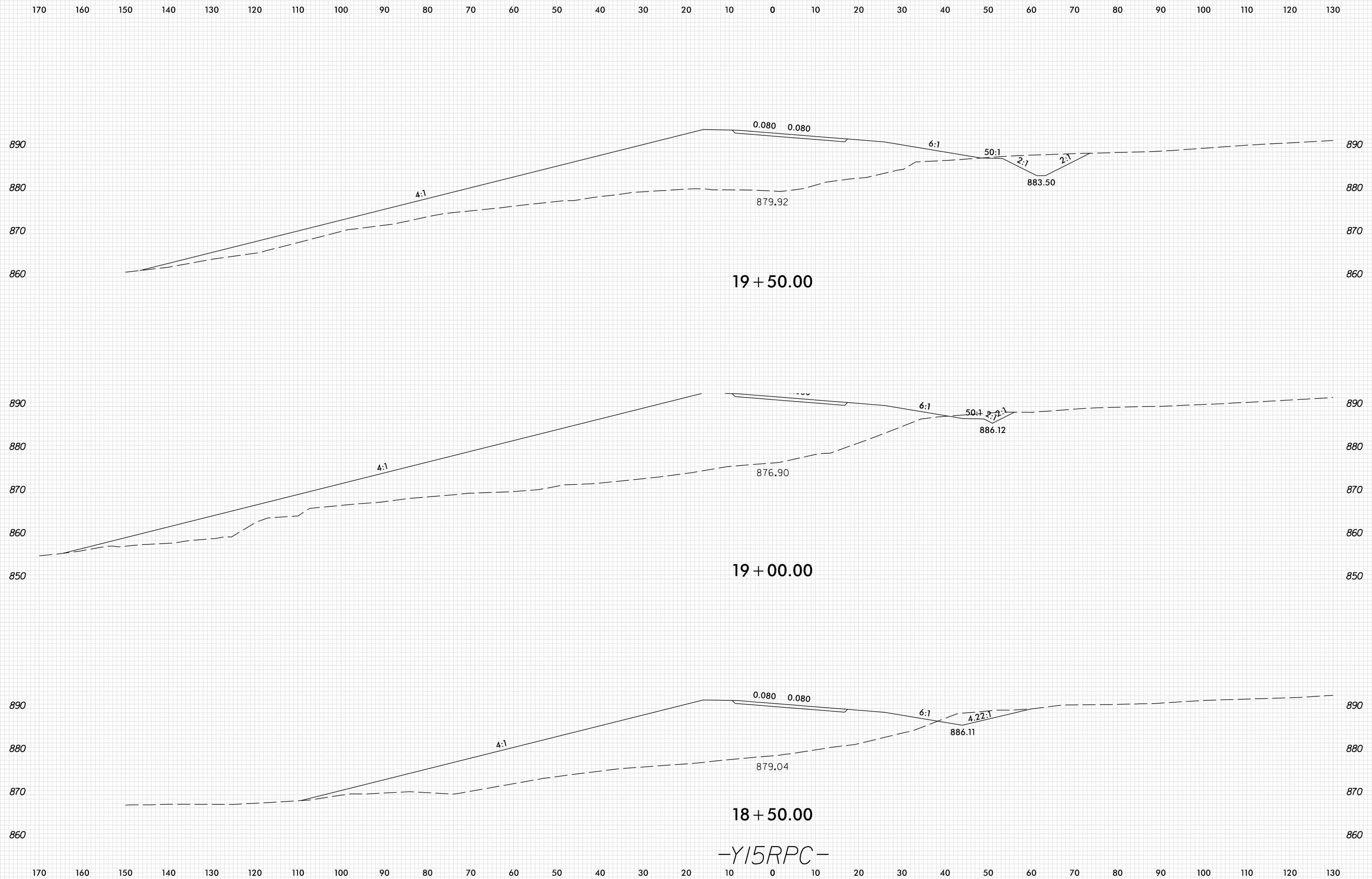

PLOT DRIVER: NCDOT\_pdf\_color\_eng\_100.plt  
 USER: SPEREIRA  
 DATE: 6/10/2021  
 TIME: 2:28:54 PM  
 FILE: \

-Y15RPC-



8/23/99

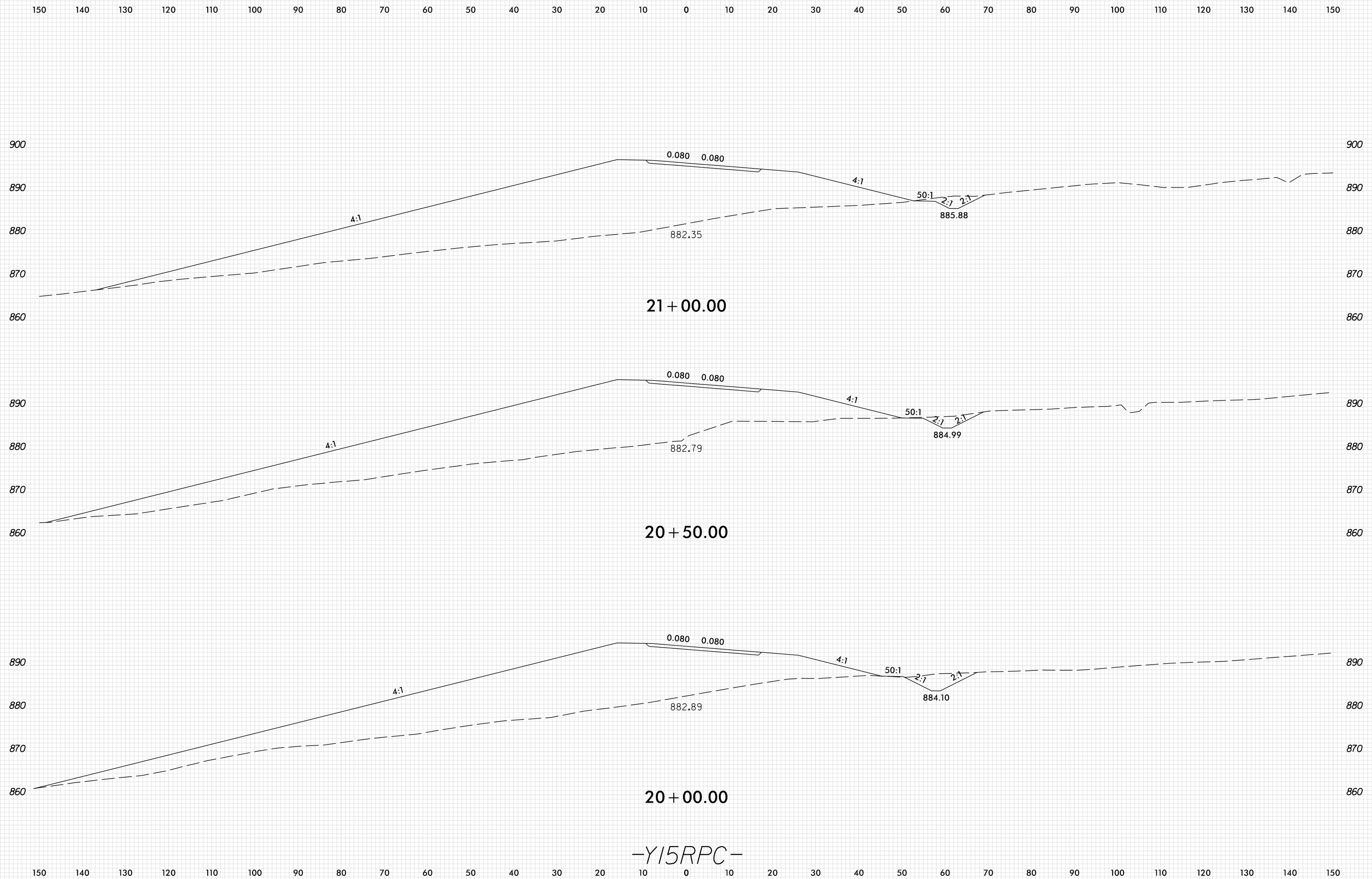

-Y15RPC-

PLOT DRIVER: NCDOT\_pdf\_color\_eng\_100.plt  
 USER: SPEREIRA  
 DATE: 6/10/2021  
 TIME: 2:28:54 PM  
 FILE: \

8/23/99

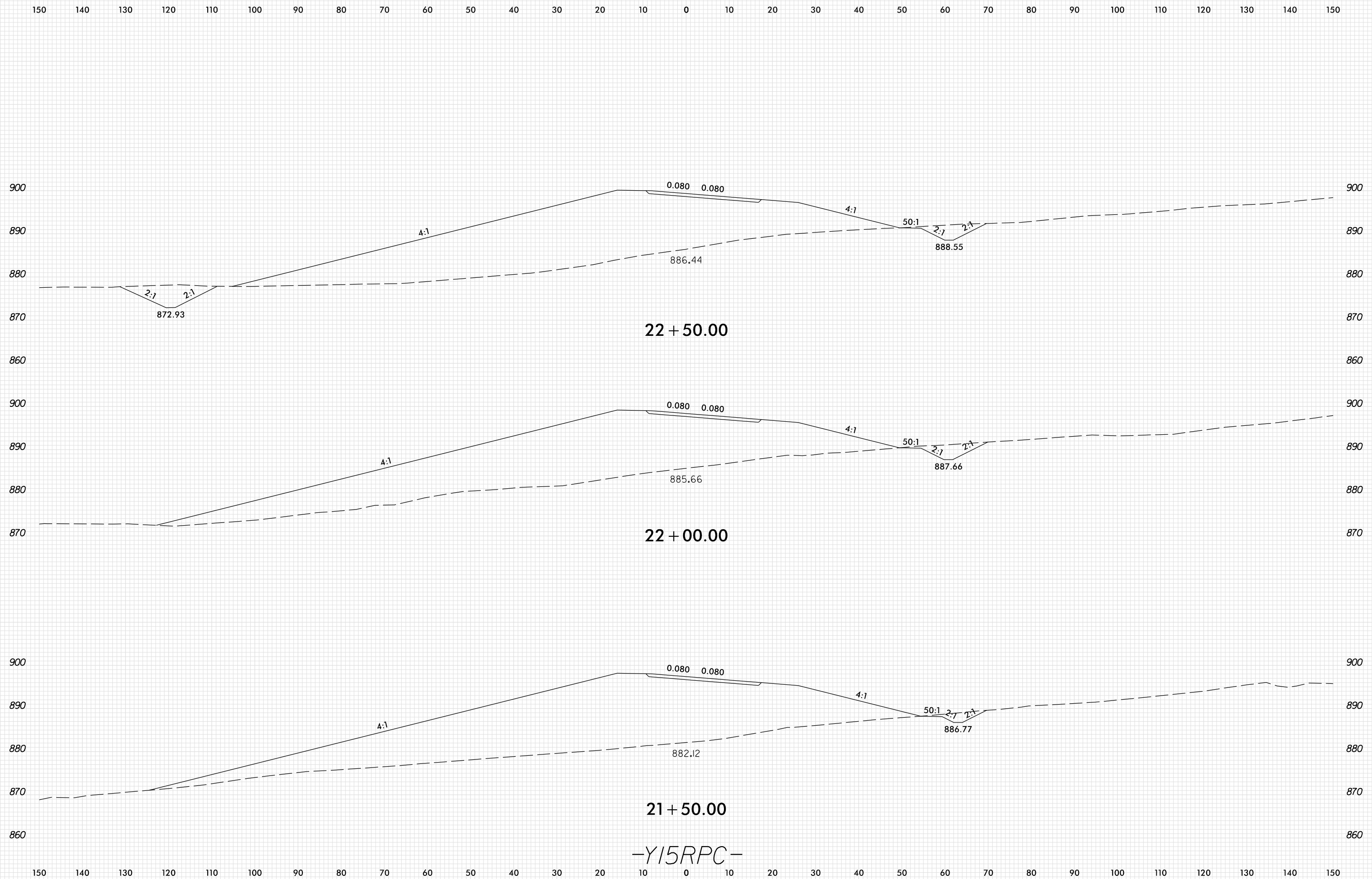

-Y15RPC-

PLOT DRIVER: NCDOT\_pdf\_color\_eng\_100.plt  
 USER: SPEREIRA  
 DATE: 6/10/2021  
 TIME: 2:28:55 PM  
 FILE: \

8/23/99



PROJ. REFERENCE NO.	SHEET NO.
U-2579AB	X-543

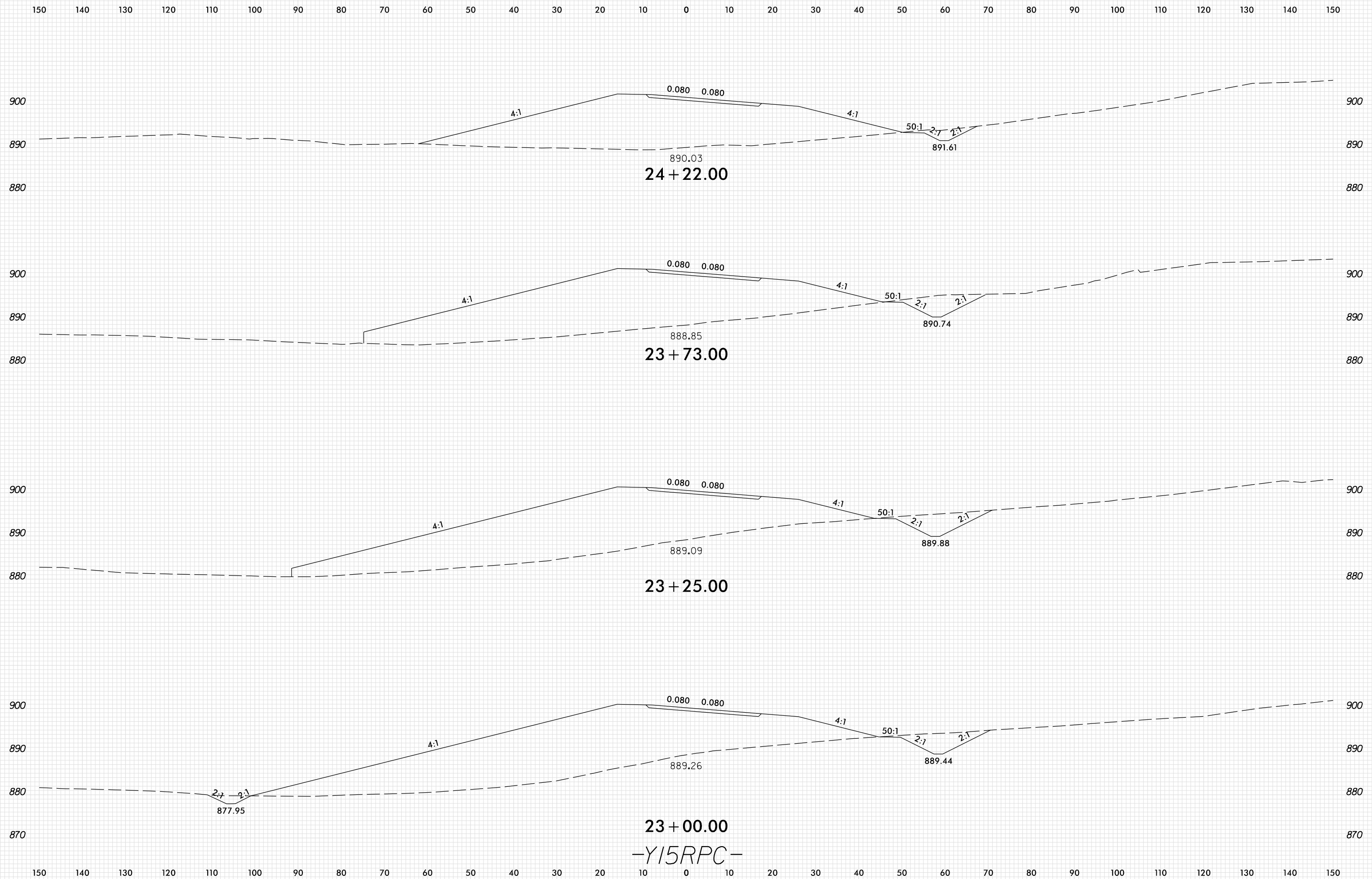

PLOT DRIVER: NCDOT\_pdf\_color\_eng\_100.plt  
 USER: SPEREIRA  
 DATE: 6/10/2021  
 TIME: 2:28:56 PM

23+00.00  
 -Y15RPC-

8/23/99

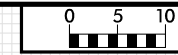

PROJ. REFERENCE NO.	SHEET NO.
U-2579AB	X-544

150 140 130 120 110 100 90 80 70 60 50 40 30 20 10 0 10 20 30 40 50 60 70 80 90 100 110 120 130 140 150

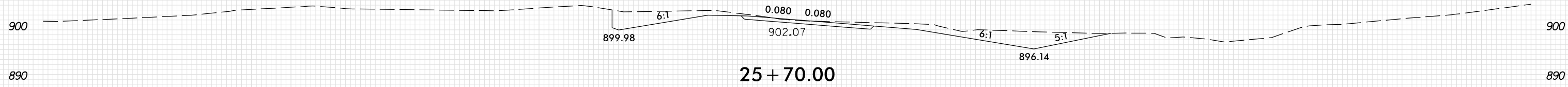

25 + 70.00

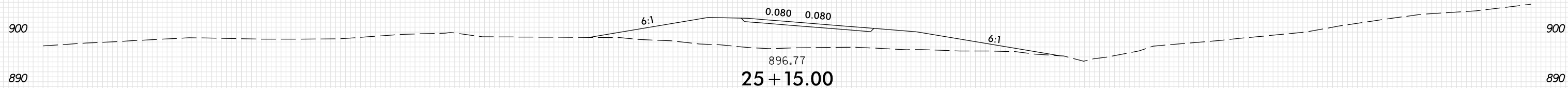

25 + 15.00

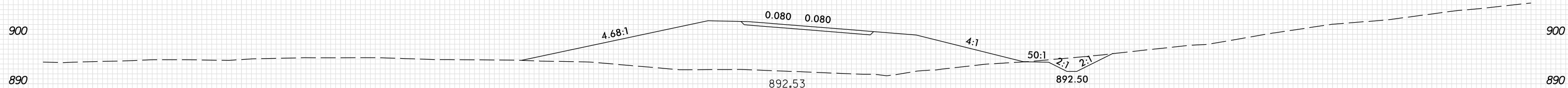

24 + 72.00

-Y15RPC-

150 140 130 120 110 100 90 80 70 60 50 40 30 20 10 0 10 20 30 40 50 60 70 80 90 100 110 120 130 140 150

PLOT DRIVER: NCD01\_pdf\_color\_eng\_100.plt  
 USER: SPEREIRA  
 DATE: 6/10/2021  
 TIME: 2:28:56 PM  
 FILE: \

8/23/99

0 5 10	PROJ. REFERENCE NO.	SHEET NO.
	U-2579AB	X-545

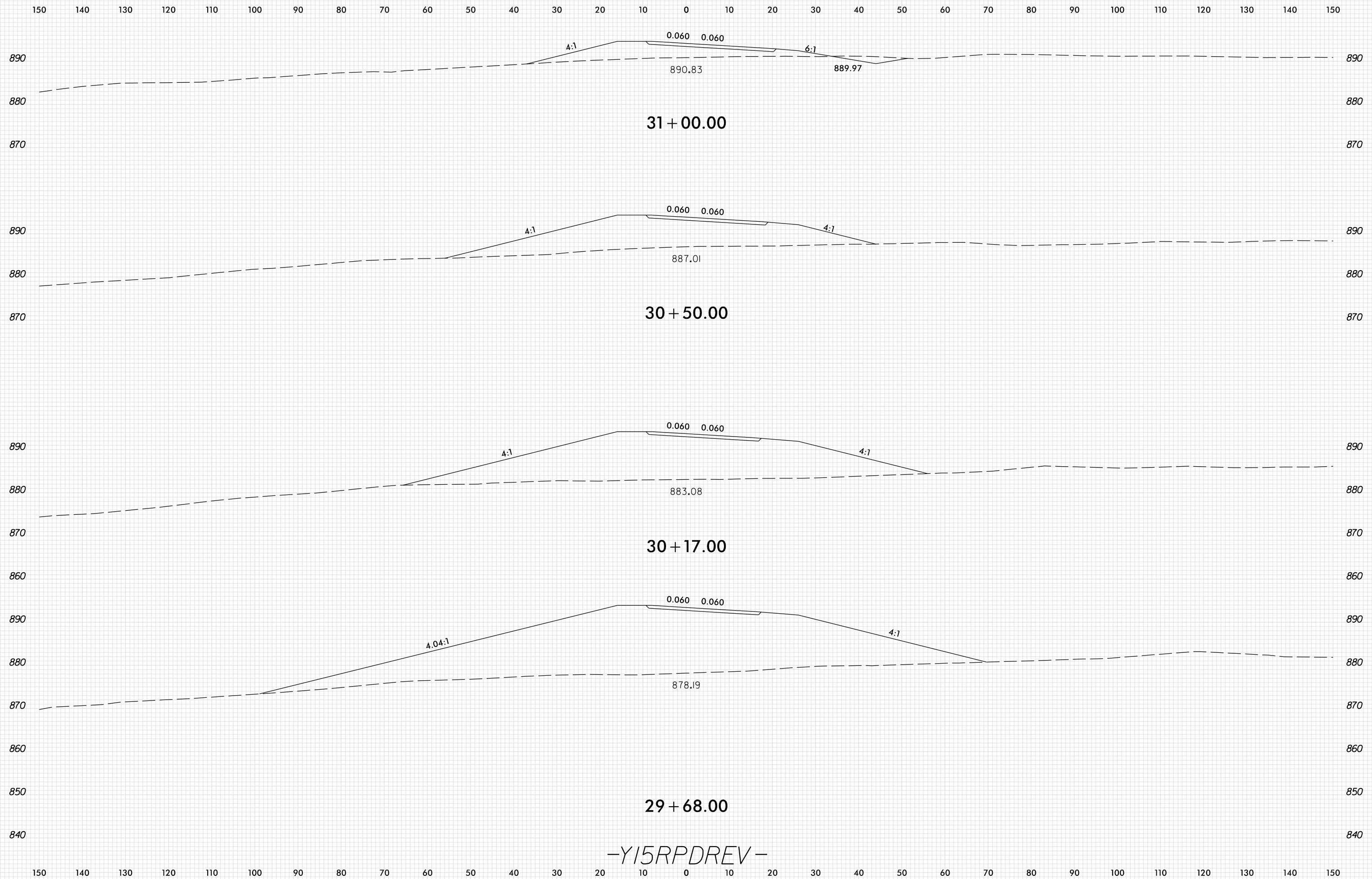

PLOT DRIVER: NCDOT\_pdf\_color\_eng\_100.plt  
 USER: SPEREIRA  
 DATE: 6/10/2021  
 TIME: 2:29:13 PM  
 FILE: \

-Y15RPDREV-

8/23/99



PROJ. REFERENCE NO.	SHEET NO.
U-2579AB	X-546

150 140 130 120 110 100 90 80 70 60 50 40 30 20 10 0 10 20 30 40 50 60 70 80 90 100 110 120 130 140 150

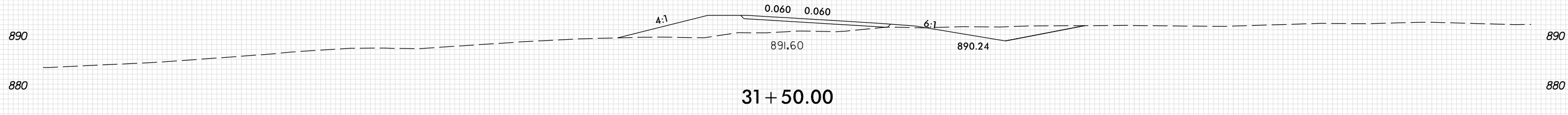
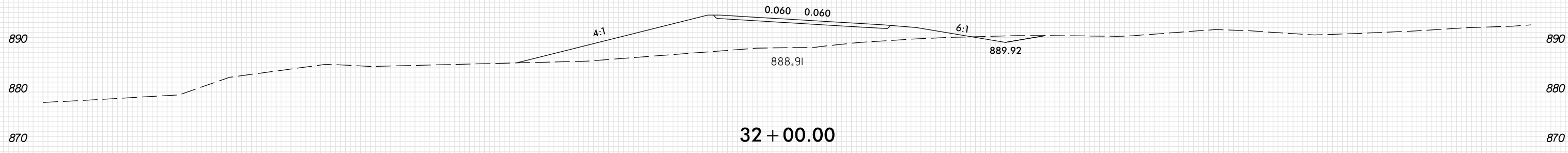
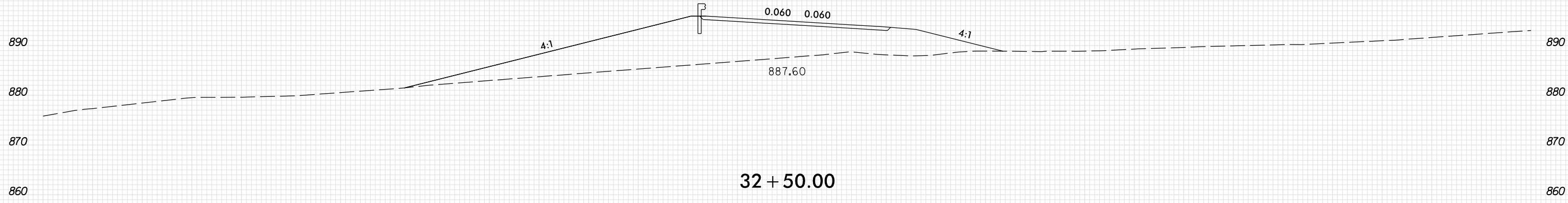

-Y15RPDREV-

PLOT DRIVER: NCD01\_pdf\_color\_eng\_100.plt  
 USER: SPEREIRA  
 DATE: 6/10/2021  
 TIME: 2:29:14 PM  
 FILE: \

8/23/99

0 5 10	PROJ. REFERENCE NO.	SHEET NO.
	U-2579AB	X-547

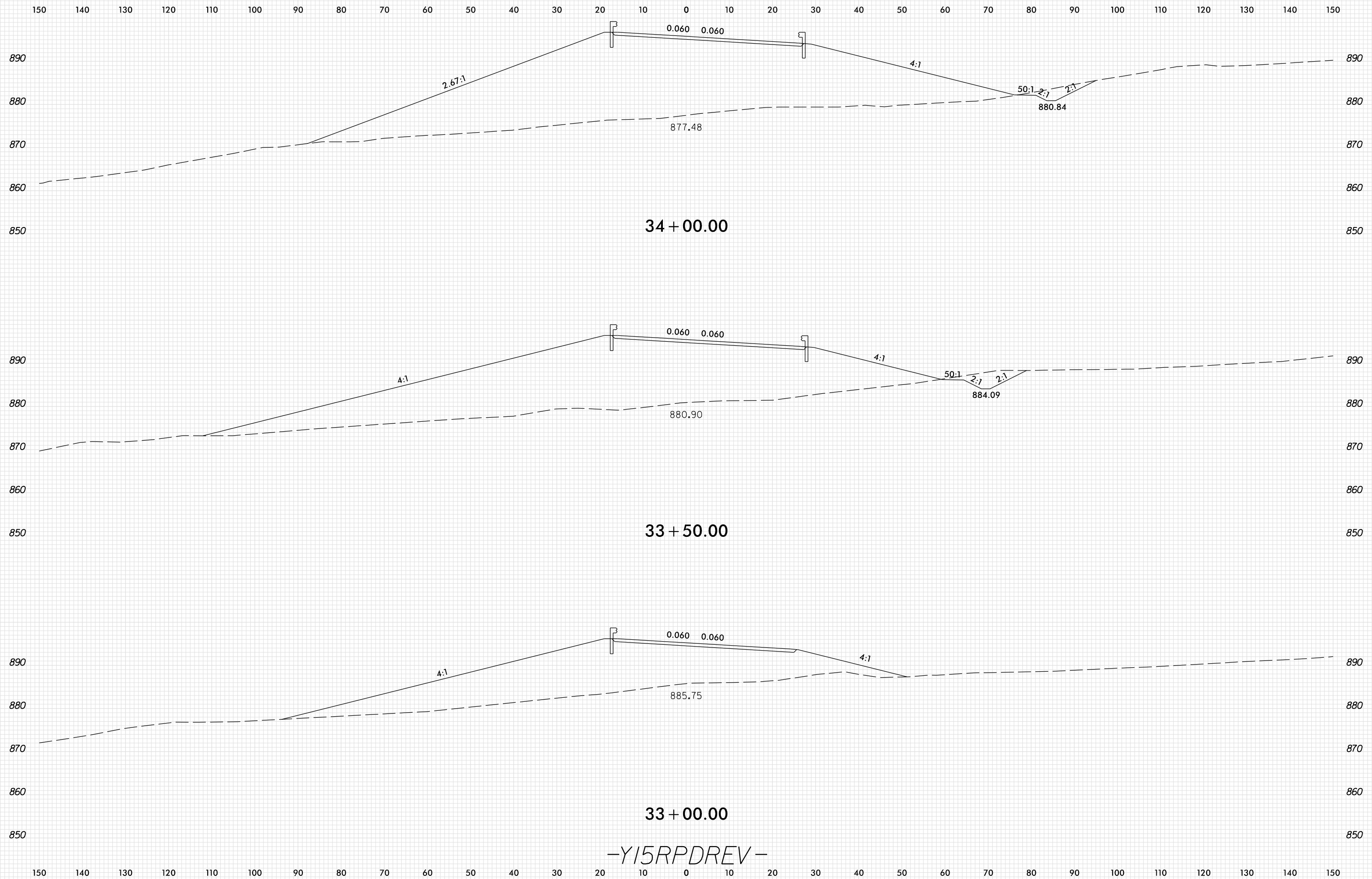

-Y15RPDREV-

PLOT DRIVER: NCDOT\_pdf\_color\_eng\_100.plt  
 USER: SPEREIRA  
 DATE: 6/10/2021  
 TIME: 2:29:14 PM  
 FILE: \

8/23/99



PROJ. REFERENCE NO.	SHEET NO.
U-2579AB	X-548

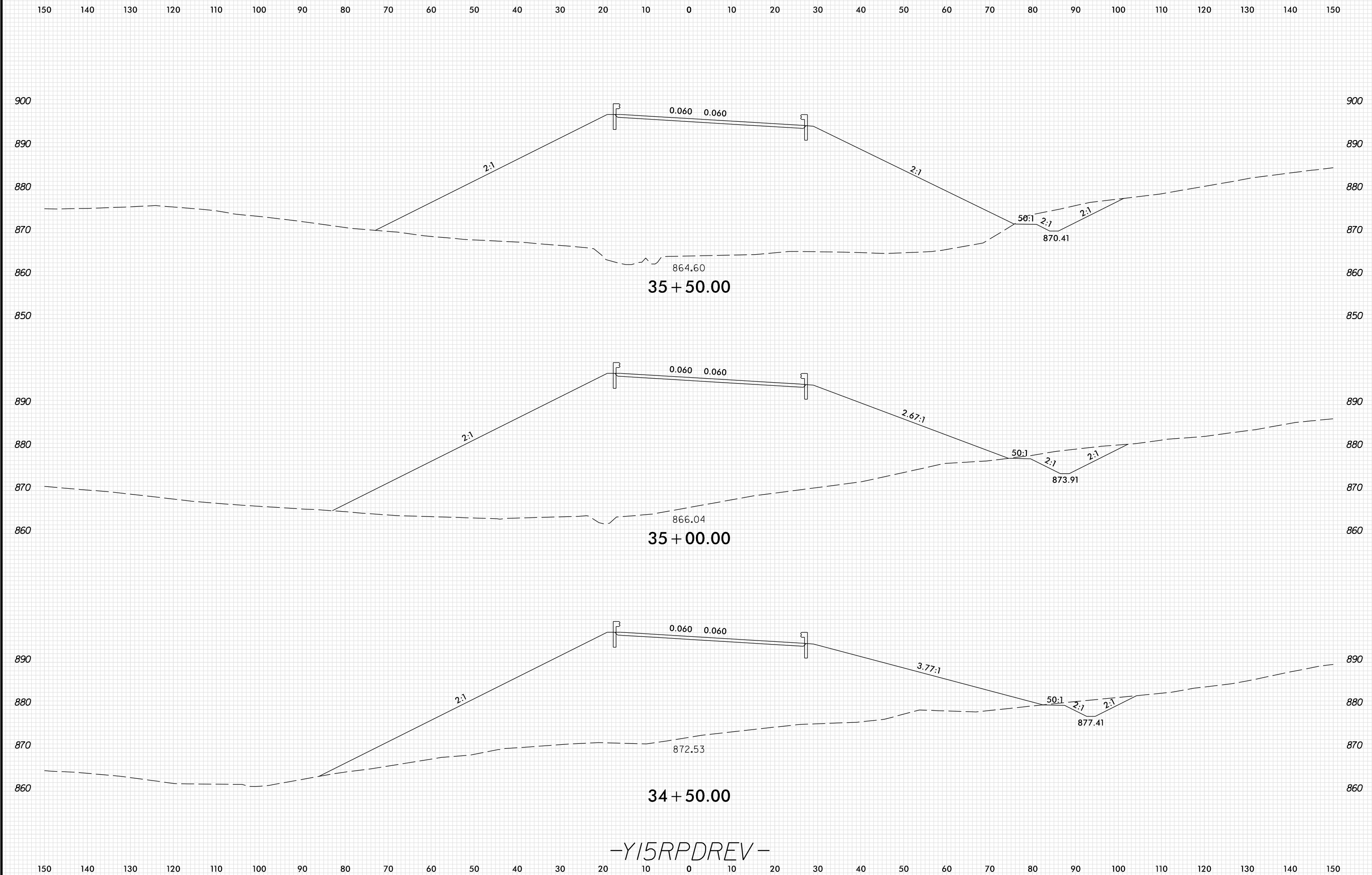

-Y15RPDREV-

PLOT DRIVER: NCDOT\_pdf\_color\_eng\_100.plt  
 USER: SPEREIRA  
 DATE: 6/10/2021  
 TIME: 2:29:15 PM  
 FILE: \



8/23/99

0 5 10	PROJ. REFERENCE NO.	SHEET NO.
	U-2579AB	X-549

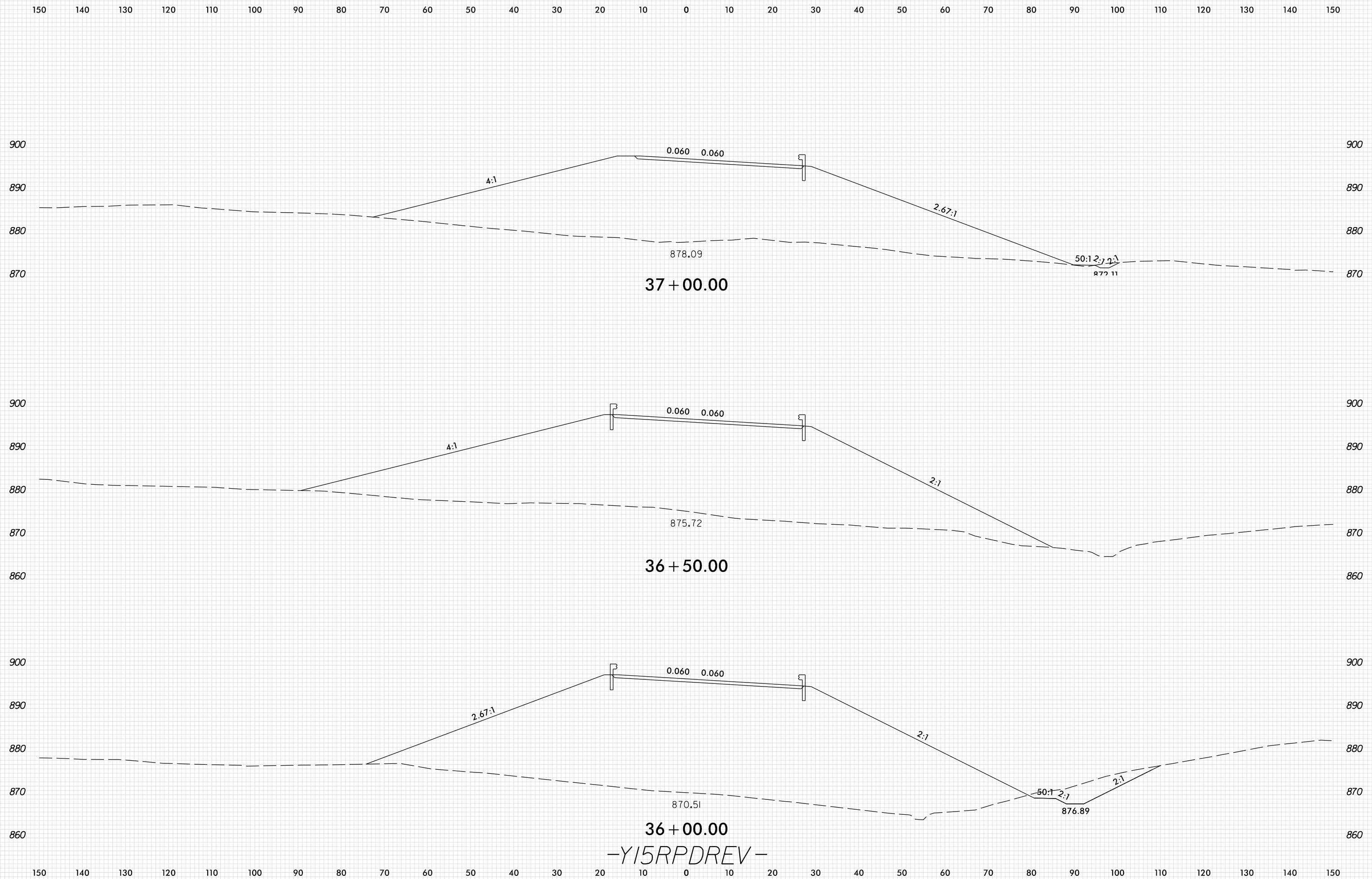

-Y15RPDREV-

PLOT DRIVER: NCDOT\_pdf\_color\_eng\_100.plt  
 USER: SPEREIRA  
 DATE: 6/10/2021  
 TIME: 2:29:16 PM  
 FILE: \

8/23/99

0 5 10	PROJ. REFERENCE NO.	SHEET NO.
	U-2579AB	X-550

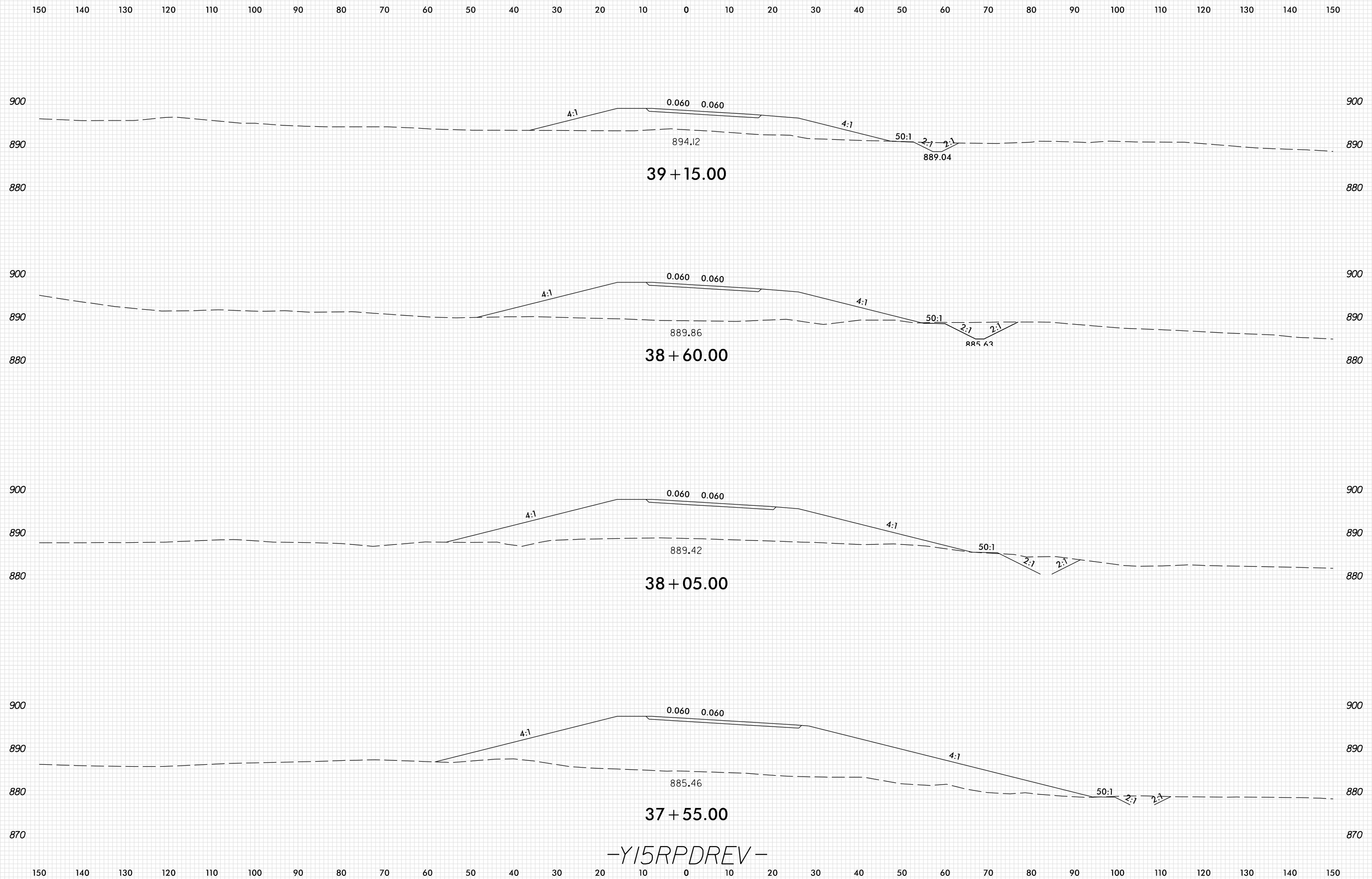

-Y15RPDREV-

PLOT DRIVER: NCDOT\_pdf\_color\_eng\_100.plt  
 USER: SPEREIRA  
 DATE: 6/10/2021  
 TIME: 2:29:17 PM  
 FILE: \

8/23/99



PROJ. REFERENCE NO.	SHEET NO.
U-2579AB	X-551

150 140 130 120 110 100 90 80 70 60 50 40 30 20 10 0 10 20 30 40 50 60 70 80 90 100 110 120 130 140 150

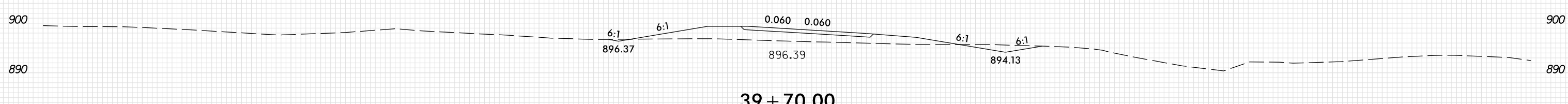
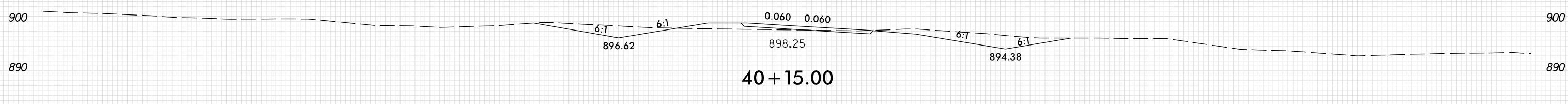
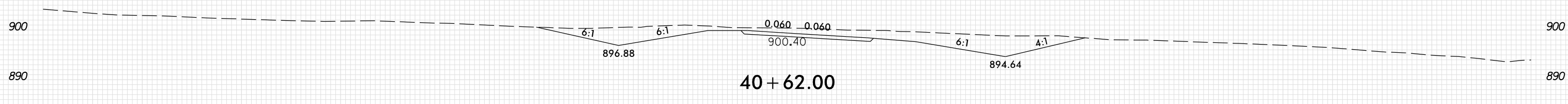
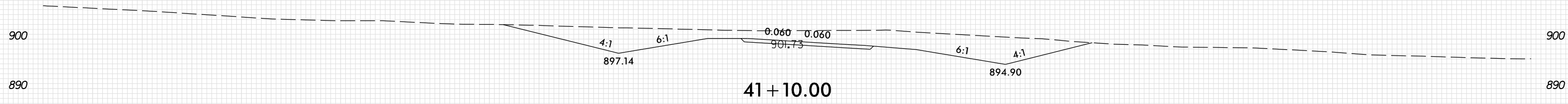

-Y15RPDREV-

150 140 130 120 110 100 90 80 70 60 50 40 30 20 10 0 10 20 30 40 50 60 70 80 90 100 110 120 130 140 150

PLOT DRIVER: NCD01\_pdf\_color\_eng\_100.plt  
 USER: SPEREIRA  
 DATE: 6/10/2021  
 TIME: 2:29:17 PM  
 FILE: \

8/23/99

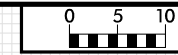

PROJ. REFERENCE NO.	SHEET NO.
U-2579AB	X-552

150 140 130 120 110 100 90 80 70 60 50 40 30 20 10 0 10 20 30 40 50 60 70 80 90 100 110 120 130 140 150

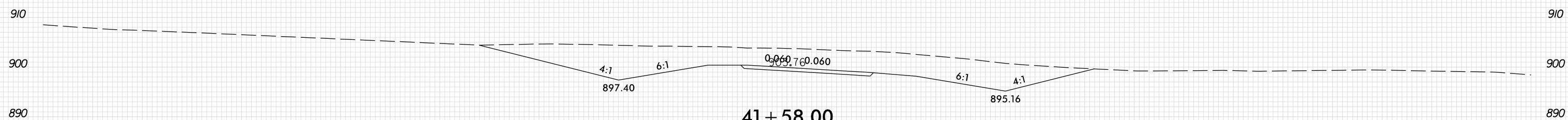
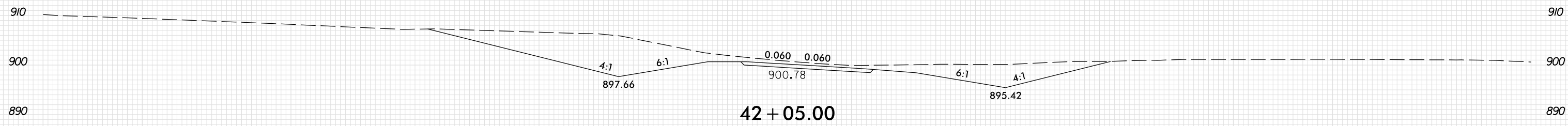
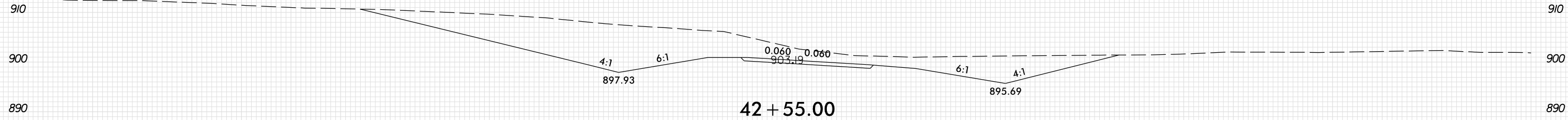

-Y15RPDREV-

PLOT DRIVER: NCD01\_pdf\_color\_eng\_100.plt  
 USER: SPEREIRA  
 DATE: 6/10/2021  
 TIME: 2:29:18 PM  
 FILE: \

150 140 130 120 110 100 90 80 70 60 50 40 30 20 10 0 10 20 30 40 50 60 70 80 90 100 110 120 130 140 150

8/23/99



PROJ. REFERENCE NO.	SHEET NO.
U-2579AB	X-553

150 140 130 120 110 100 90 80 70 60 50 40 30 20 10 0 10 20 30 40 50 60 70 80 90 100 110 120 130 140 150

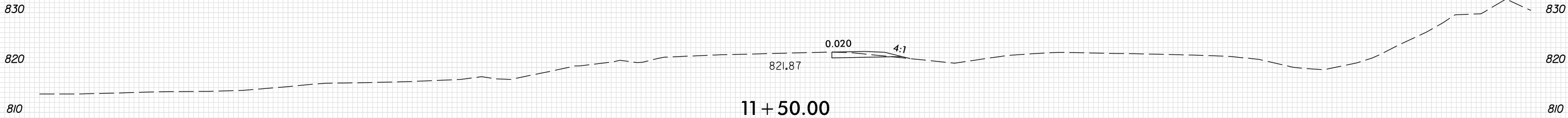

11+50.00

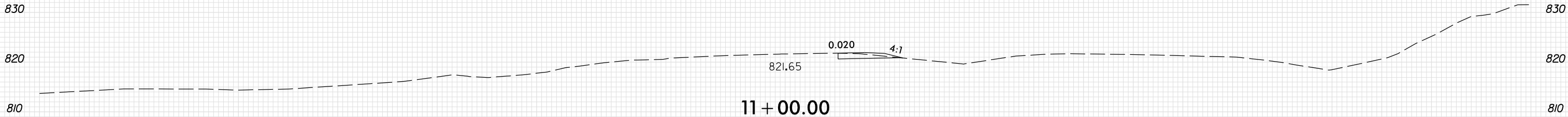

11+00.00

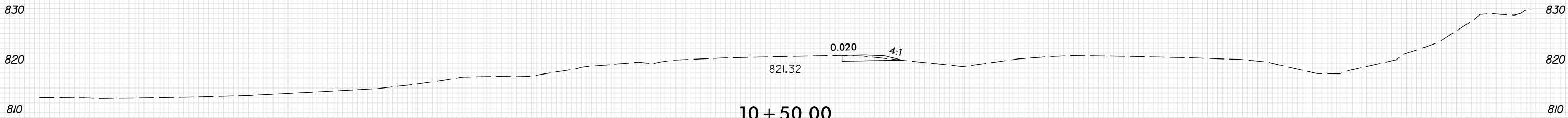

10+50.00

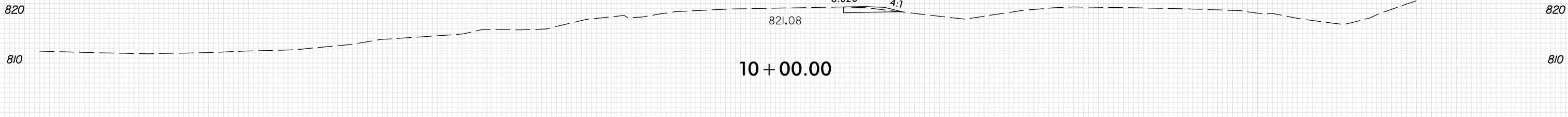

10+00.00

-Y15X0VRI-

150 140 130 120 110 100 90 80 70 60 50 40 30 20 10 0 10 20 30 40 50 60 70 80 90 100 110 120 130 140 150

PLOT DRIVER: NCD01\_pdf\_color\_eng\_100.plt  
 USER: SPEREIRA  
 DATE: 6/10/2021  
 TIME: 2:29:38 PM  
 FILE: \



150 140 130 120 110 100 90 80 70 60 50 40 30 20 10 0 10 20 30 40 50 60 70 80 90 100 110 120 130 140 150

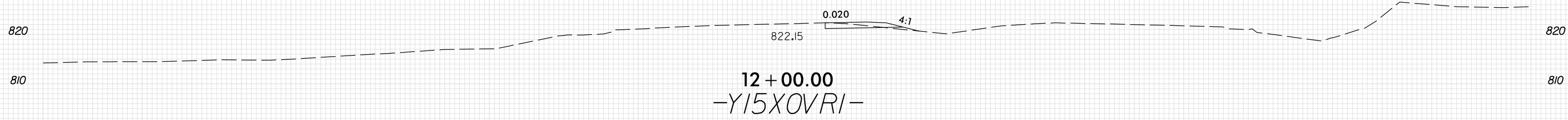
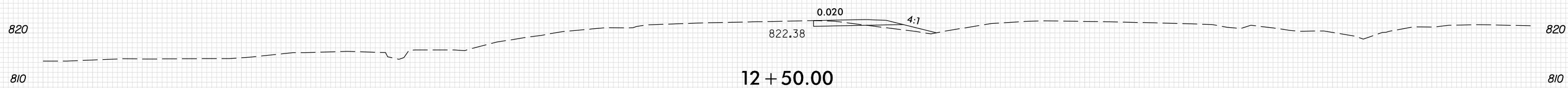
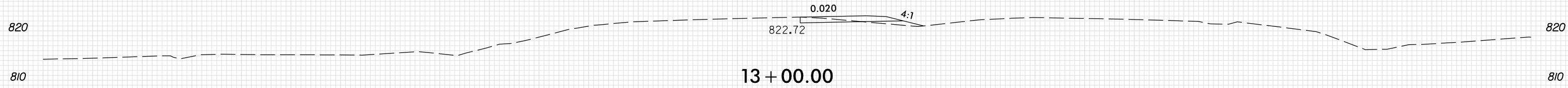
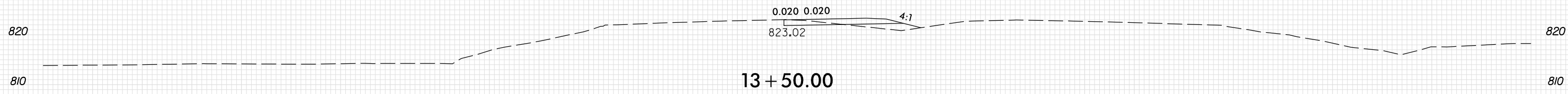
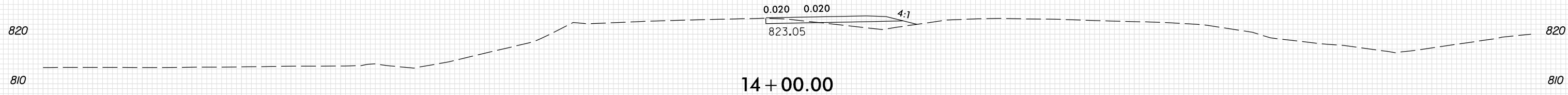

150 140 130 120 110 100 90 80 70 60 50 40 30 20 10 0 10 20 30 40 50 60 70 80 90 100 110 120 130 140 150

8/23/99

0 5 10	PROJ. REFERENCE NO.	SHEET NO.
	U-2579AB	X-555

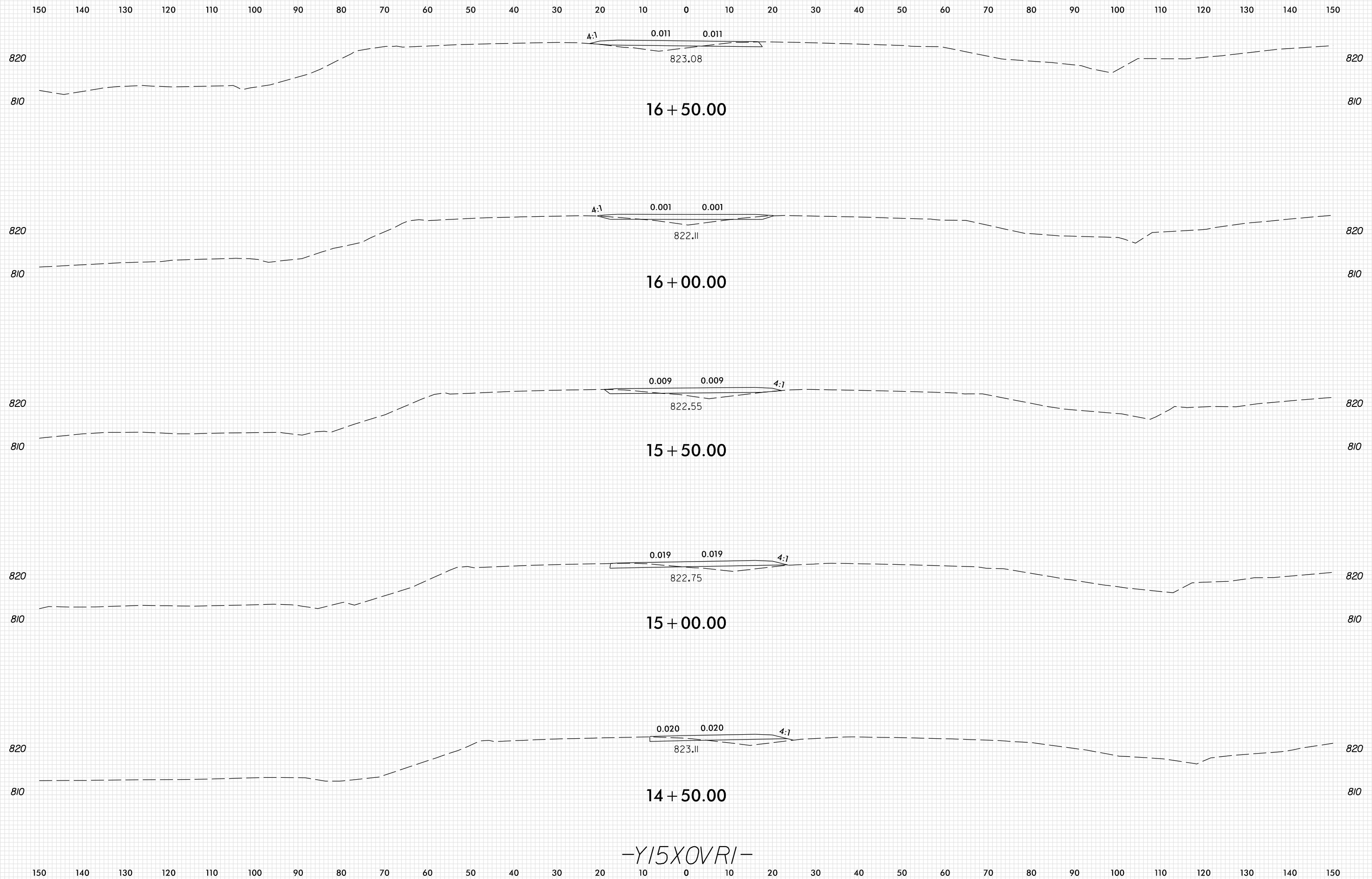

-Y15XOVR1-

PLOT DRIVER: NCD01\_pdf\_color\_eng\_100.plt  
 USER: SPEREIRA  
 DATE: 6/10/2021  
 TIME: 2:29:39 PM  
 FILE: \

8/23/99

0 5 10	PROJ. REFERENCE NO.	SHEET NO.
	U-2579AB	X-556

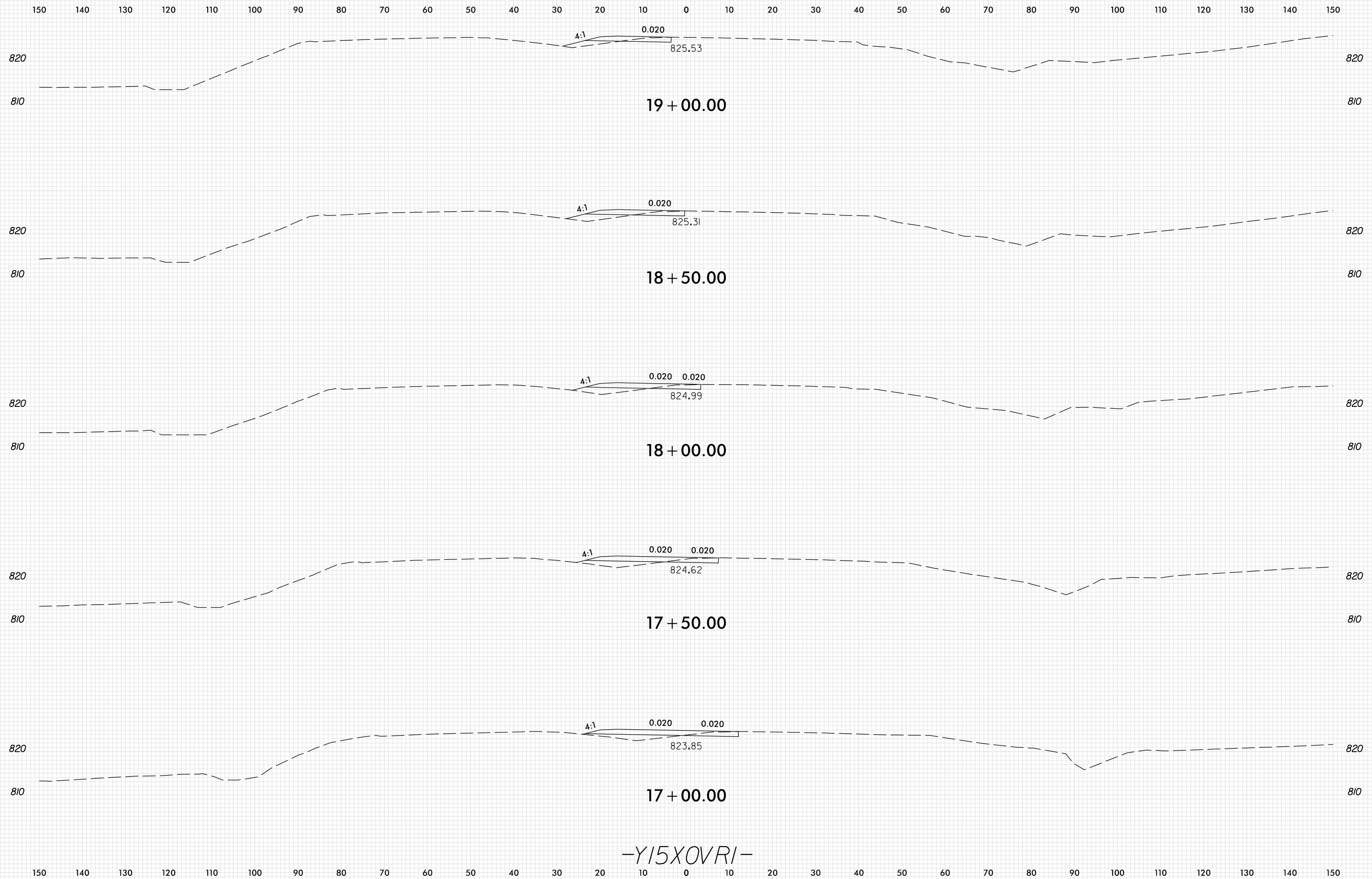

-Y15XOVR1-

PLOT DRIVER: NCDOT\_pdf\_color\_eng\_100.plt  
 USER: SPEREIRA  
 DATE: 6/10/2021  
 TIME: 2:29:40 PM  
 FILE: \



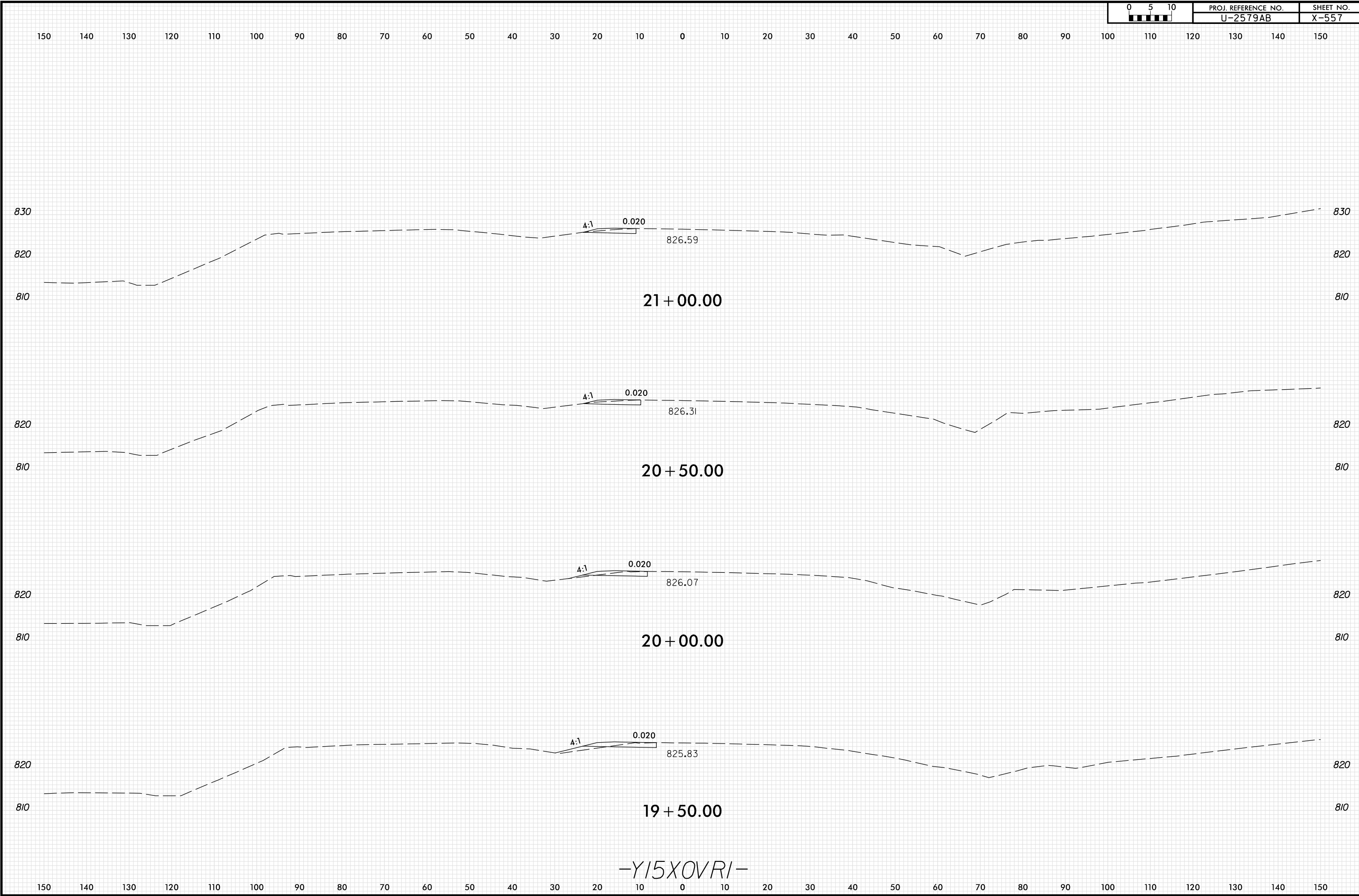

-Y15XOVR1-

8/23/99

0 5 10	PROJ. REFERENCE NO.	SHEET NO.
	U-2579AB	X-558

150 140 130 120 110 100 90 80 70 60 50 40 30 20 10 0 10 20 30 40 50 60 70 80 90 100 110 120 130 140 150

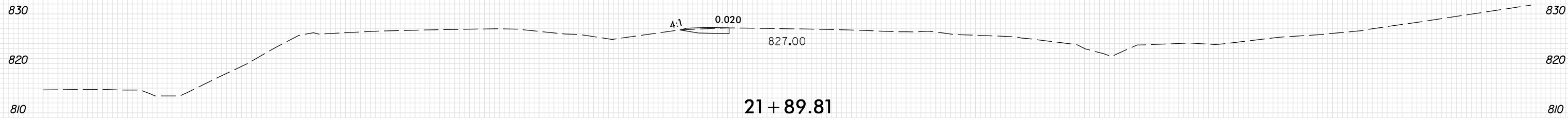

21 + 89.81

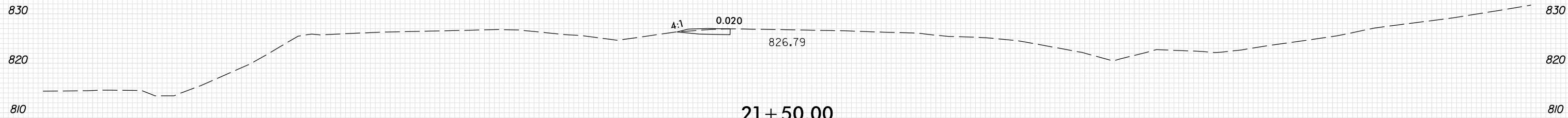

21 + 50.00

-Y15X0VRI-

150 140 130 120 110 100 90 80 70 60 50 40 30 20 10 0 10 20 30 40 50 60 70 80 90 100 110 120 130 140 150

PLOT DRIVER: NCD01\_pdf\_color\_eng\_100.plt  
USER: SPEREIRA  
DATE: 6/10/2021  
TIME: 2:29:41 PM  
FILE: \

8/23/99

0 5 10	PROJ. REFERENCE NO.	SHEET NO.
	U-2579AB	X-559

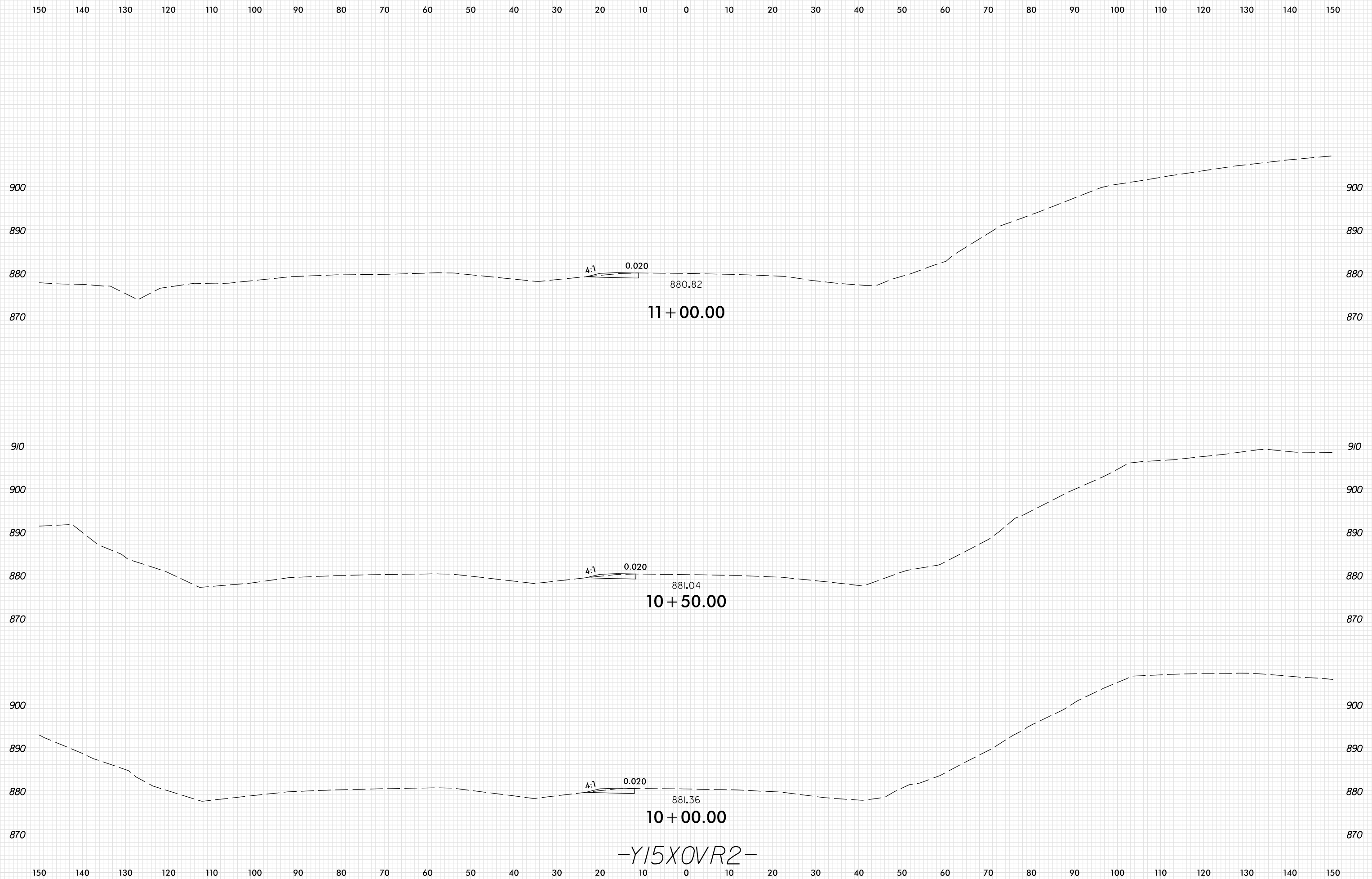

PLOT DRIVER: NCD01\_pdf\_color\_eng\_100.plt  
 USER: SPEREIRA  
 DATE: 6/10/2021  
 TIME: 2:29:51 PM  
 FILE: \

8/23/99

0 5 10	PROJ. REFERENCE NO.	SHEET NO.
	U-2579AB	X-560

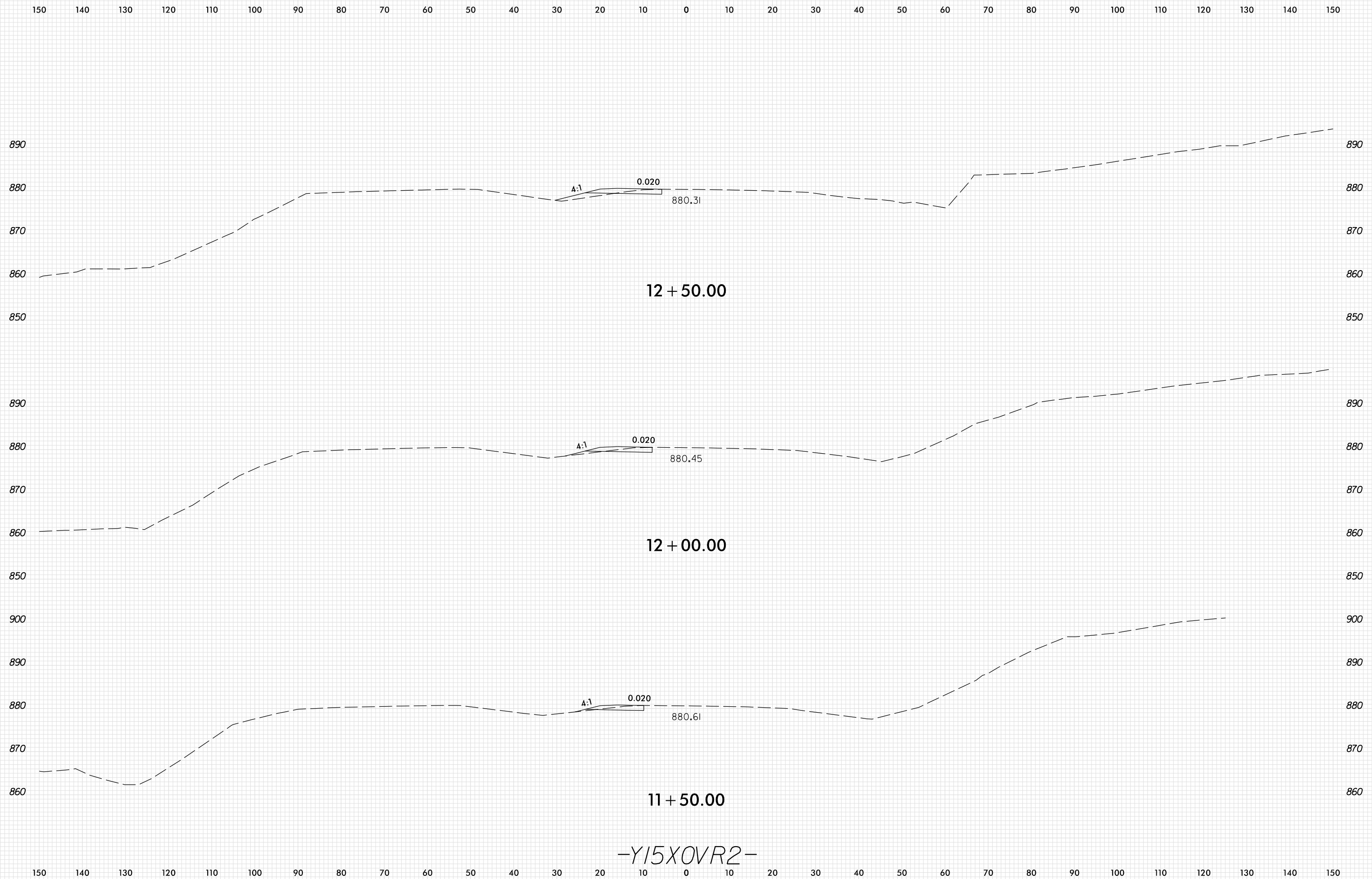

-Y15X0VR2-

PLOT DRIVER: NCD01\_pdf\_color\_eng\_100.plt  
 USER: SPEREIRA  
 DATE: 6/10/2021  
 TIME: 2:29:52 PM  
 FILE: \

8/23/99

0 5 10	PROJ. REFERENCE NO.	SHEET NO.
	U-2579AB	X-561

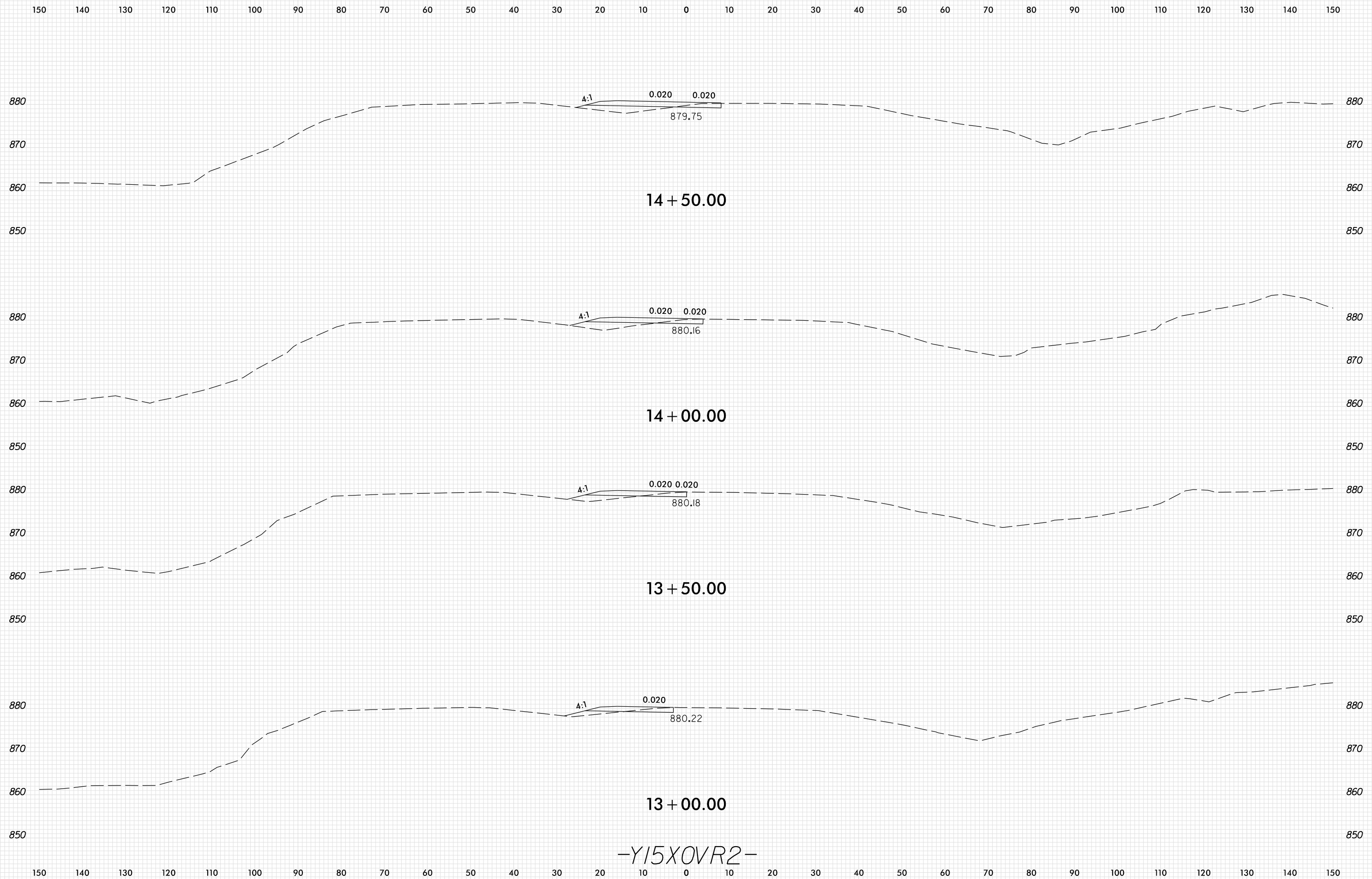

PLOT DRIVER: NCDOT\_pdf\_color\_eng\_100.plt  
 USER: SPEREIRA  
 DATE: 6/10/2021  
 TIME: 2:29:52 PM  
 FILE: \

-Y15X0VR2-

8/23/99

0 5 10	PROJ. REFERENCE NO.	SHEET NO.
	U-2579AB	X-562

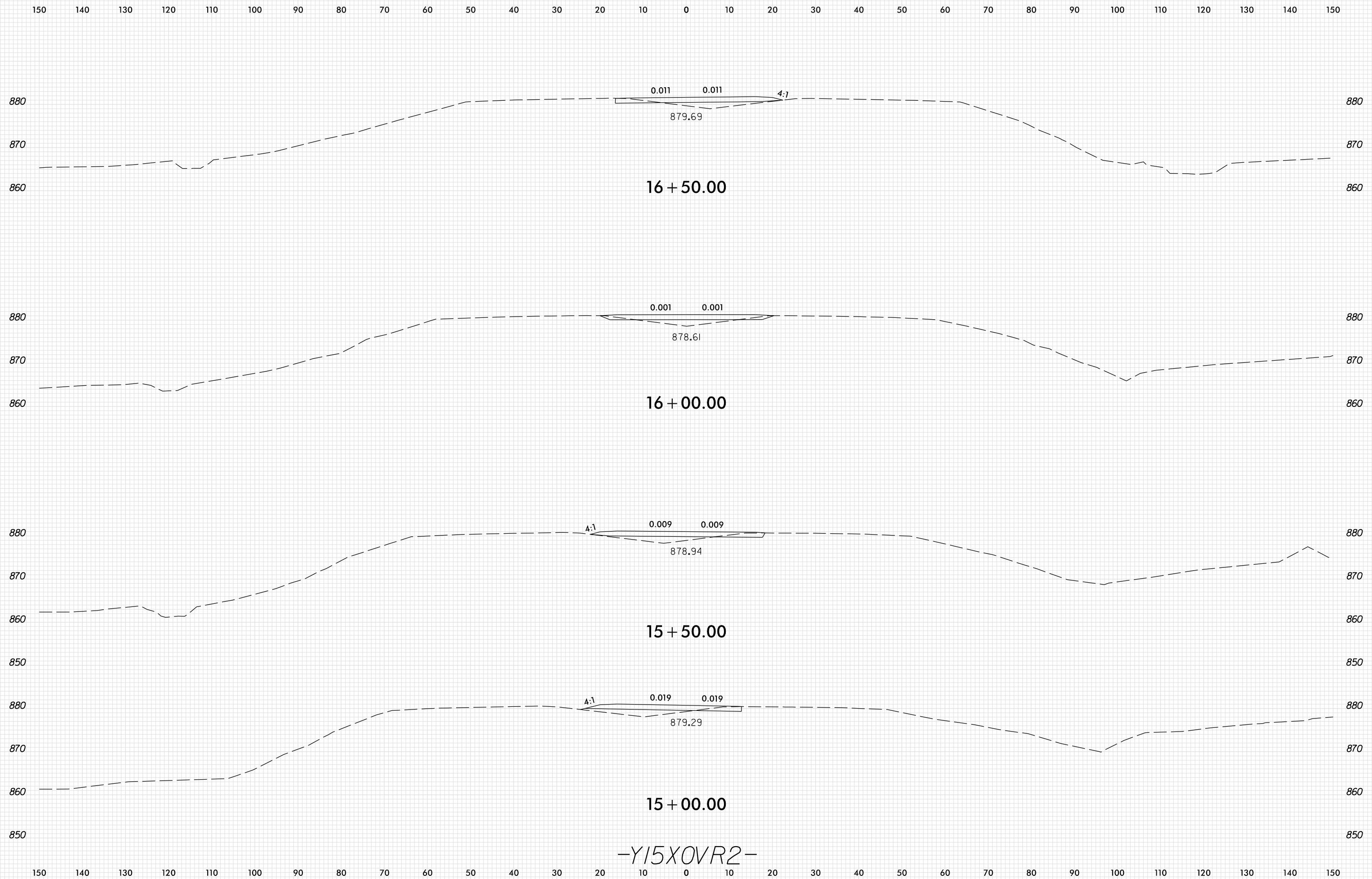

-Y15X0VR2-

PLOT DRIVER: NCD01\_pdf\_color\_eng\_100.plt  
 USER: SPEREIRA  
 DATE: 6/10/2021  
 TIME: 2:29:53 PM  
 FILE: \

8/23/99

0 5 10	PROJ. REFERENCE NO.	SHEET NO.
	U-2579AB	X-563

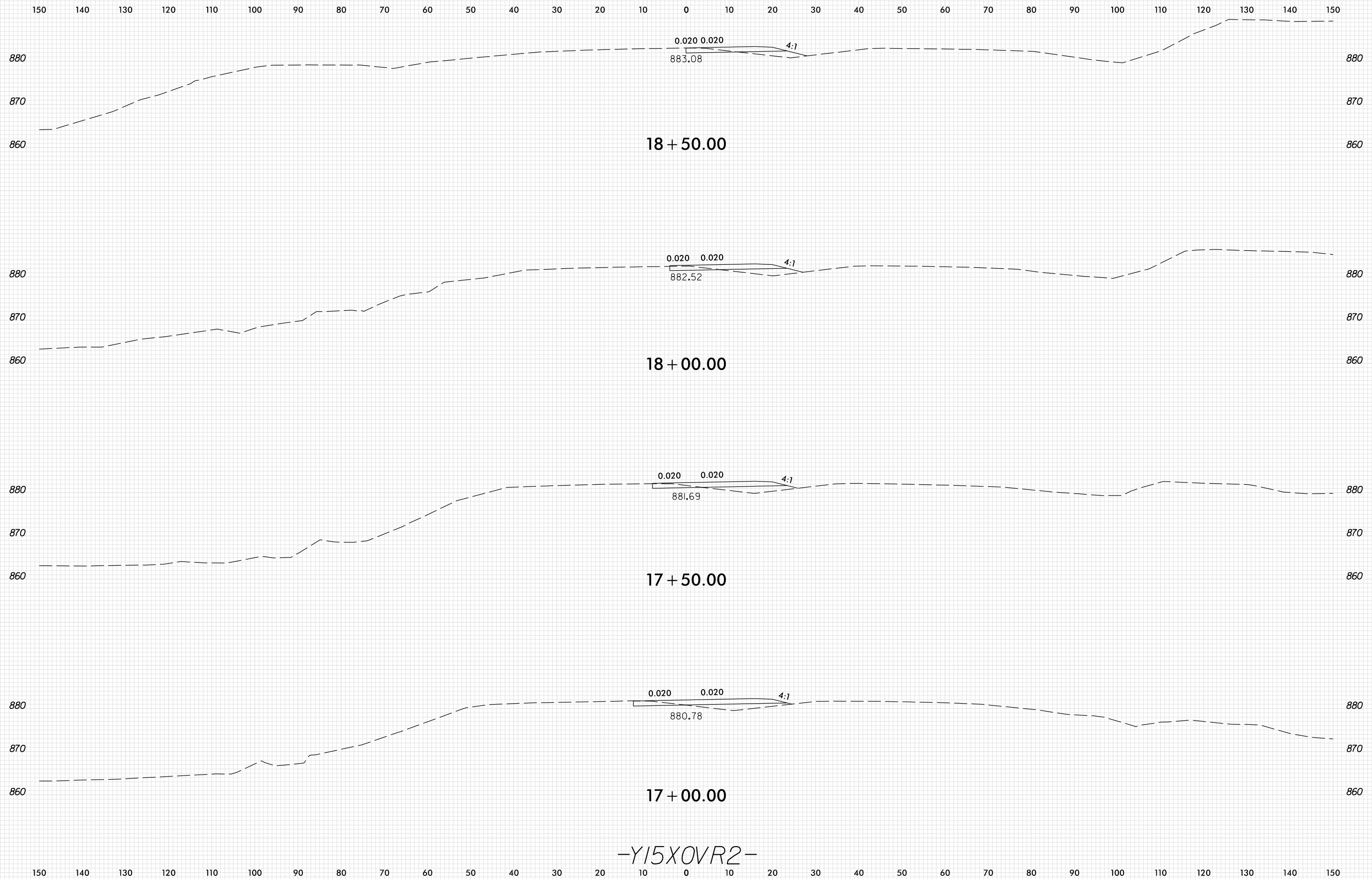

-Y15X0VR2-

PLOT DRIVER: NCDOT\_pdf\_color\_eng\_100.plt  
 USER: SPEREIRA  
 DATE: 6/10/2021  
 TIME: 2:29:53 PM  
 FILE: \

8/23/99



PROJ. REFERENCE NO.	SHEET NO.
U-2579AB	X-564

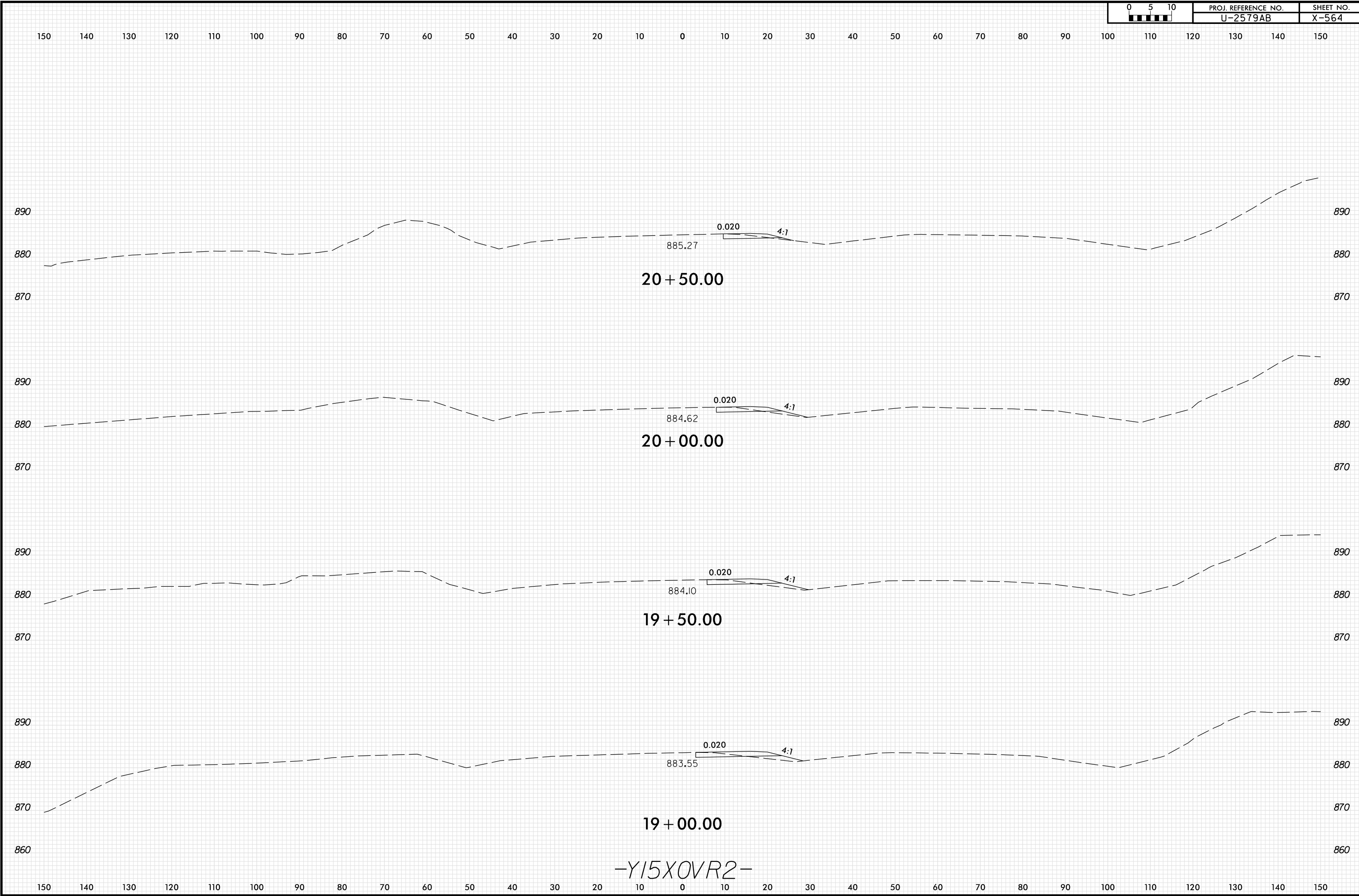

PLOT DRIVER: NCD01\_.pdf\_color\_eng\_100.plt  
 USER: SPEREIRA  
 DATE: 6/10/2021  
 TIME: 2:29:54 PM  
 FILE: \



8/23/99

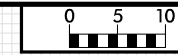

PROJ. REFERENCE NO.	SHEET NO.
U-2579AB	X-565

150 140 130 120 110 100 90 80 70 60 50 40 30 20 10 0 10 20 30 40 50 60 70 80 90 100 110 120 130 140 150

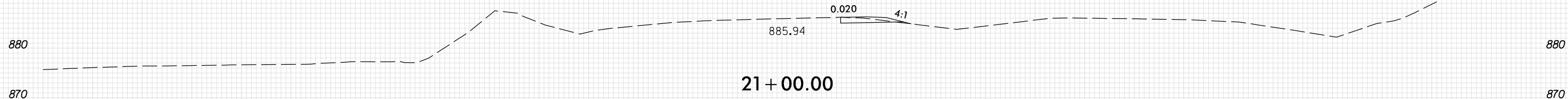
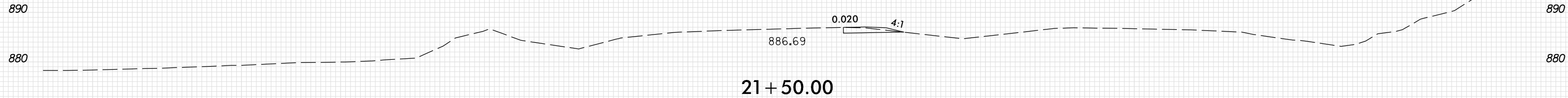
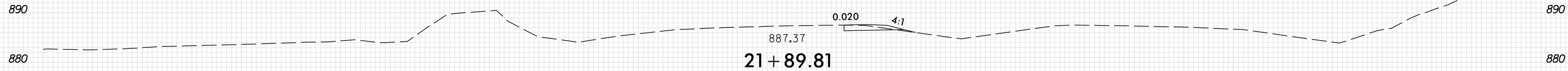

-Y15X0VR2-

150 140 130 120 110 100 90 80 70 60 50 40 30 20 10 0 10 20 30 40 50 60 70 80 90 100 110 120 130 140 150

PLOT DRIVER: NCDOT\_pdf\_color\_eng\_100.plt  
 USER: SPEREIRA  
 DATE: 6/10/2021  
 TIME: 2:29:55 PM  
 FILE: \

8/23/99

150 140 130 120 110 100 90 80 70 60 50 40 30 20 10 0 10 20 30 40 50 60 70 80 90 100 110 120 130 140 150

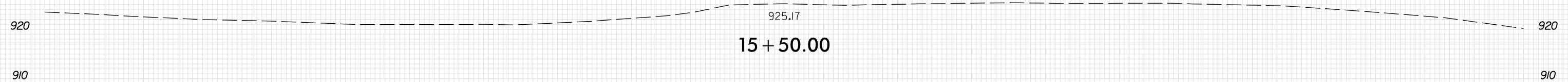
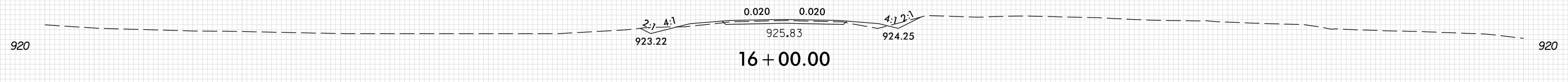
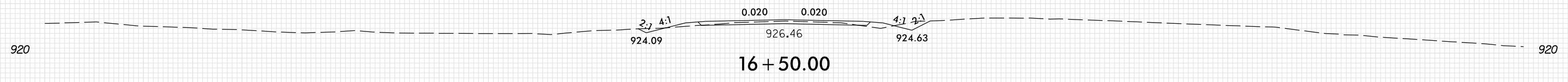
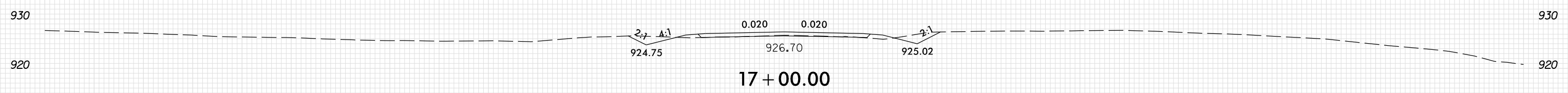
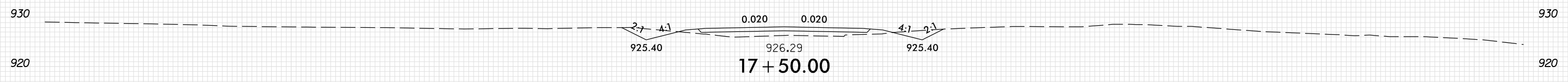

-Y16-

150 140 130 120 110 100 90 80 70 60 50 40 30 20 10 0 10 20 30 40 50 60 70 80 90 100 110 120 130 140 150

PLOT DRIVER: NCDOT\_pdf\_color\_eng\_100.plt  
 USER: SPEREIRA  
 DATE: 6/10/2021  
 TIME: 2:30:05 PM  
 FILE: \

8/23/99



PROJ. REFERENCE NO.	SHEET NO.
U-2579AB	X-567

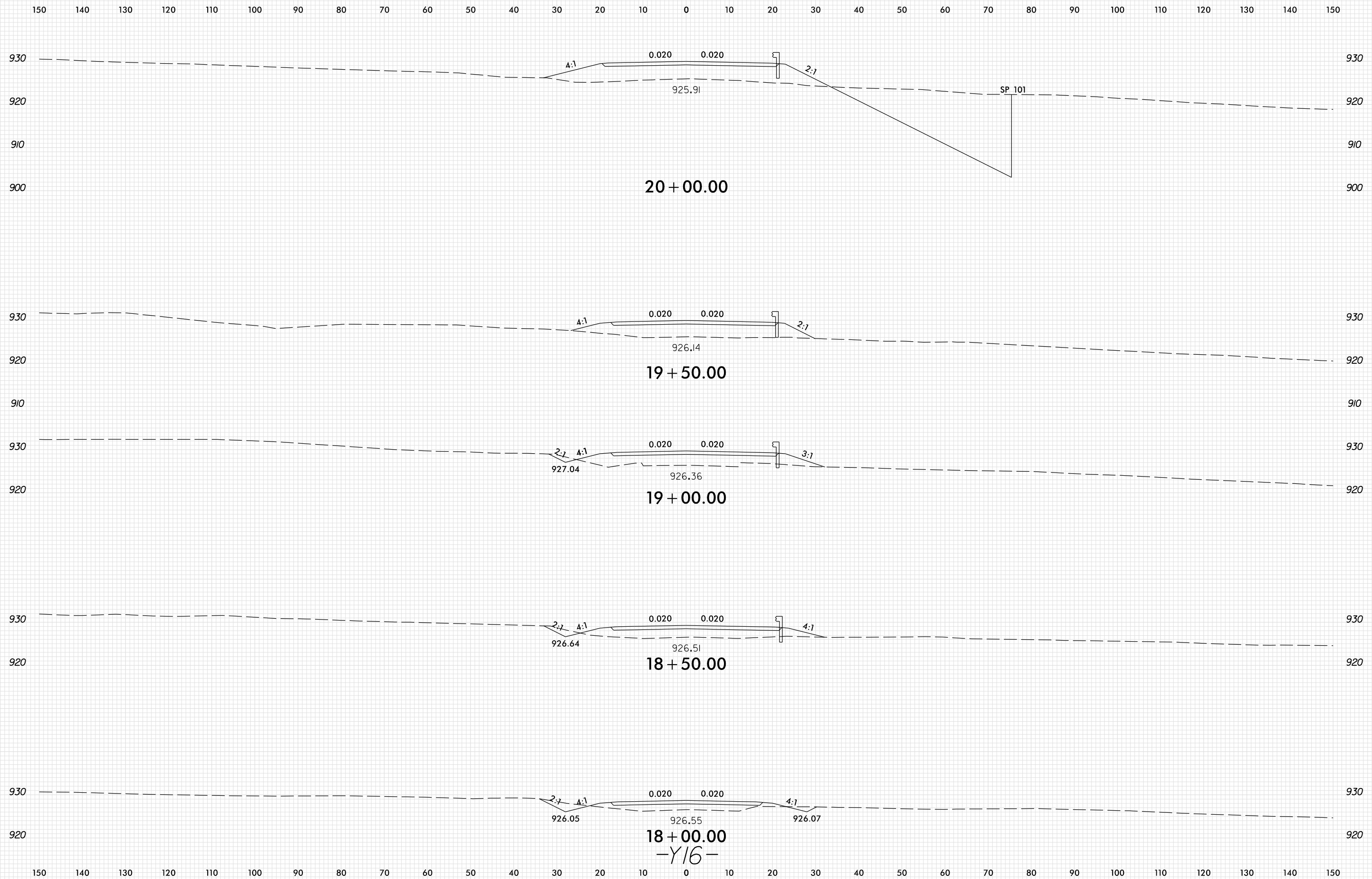

18 + 00.00  
-Y16-

PLOT DRIVER: NCDOT\_pdf\_color\_eng\_100.plt  
 USER: SPEREIRA  
 DATE: 6/10/2021  
 TIME: 2:30:05 PM  
 FILE: \

8/23/99



PROJ. REFERENCE NO.	SHEET NO.
U-2579AB	X-568

150 140 130 120 110 100 90 80 70 60 50 40 30 20 10 0 10 20 30 40 50 60 70 80 90 100 110 120 130 140 150

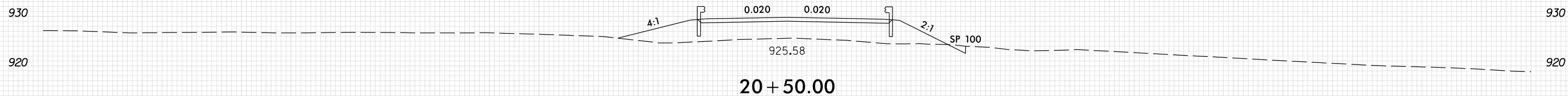
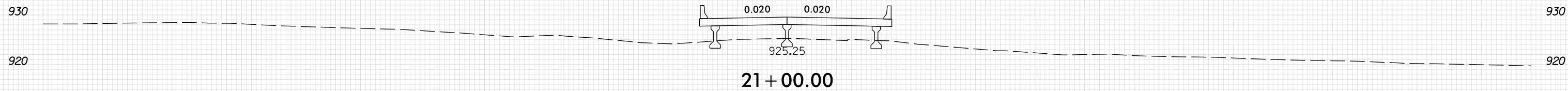
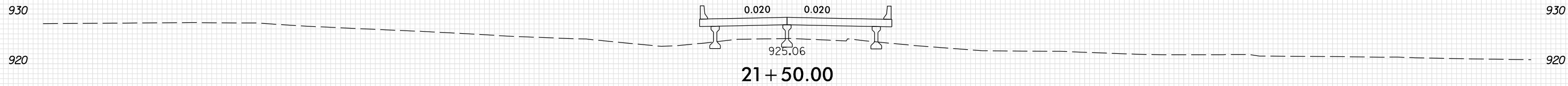
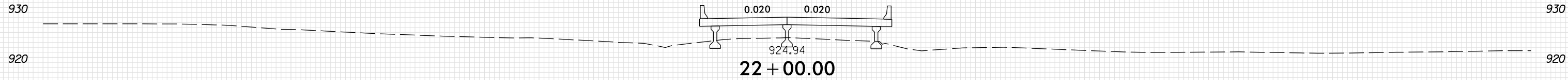
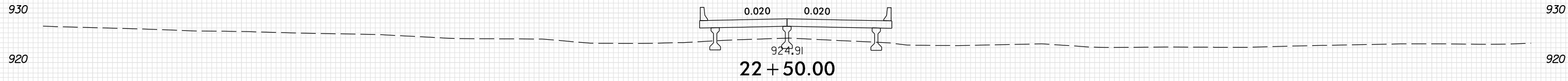

-Y16-

150 140 130 120 110 100 90 80 70 60 50 40 30 20 10 0 10 20 30 40 50 60 70 80 90 100 110 120 130 140 150

PLOT DRIVER: NCDOT\_pdf\_color\_eng\_100.plt  
 USER: SPEREIRA  
 DATE: 6/10/2021  
 TIME: 2:30:06 PM  
 FILE: \

8/23/99

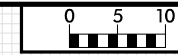

PROJ. REFERENCE NO.	SHEET NO.
U-2579AB	X-569

150 140 130 120 110 100 90 80 70 60 50 40 30 20 10 0 10 20 30 40 50 60 70 80 90 100 110 120 130 140 150

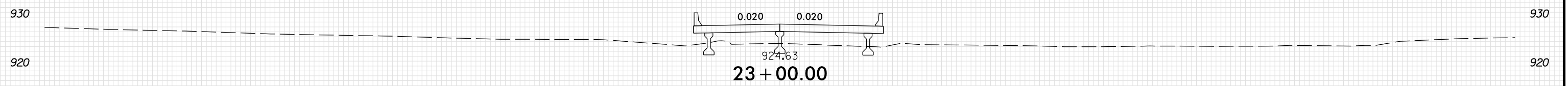
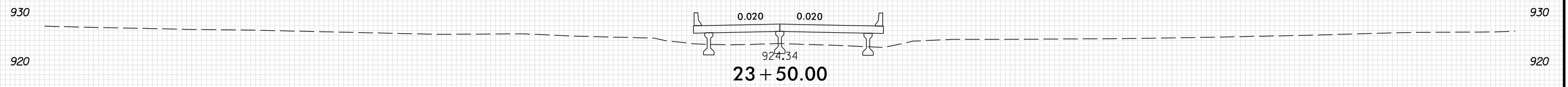
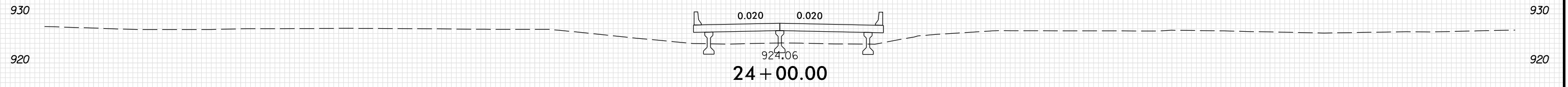
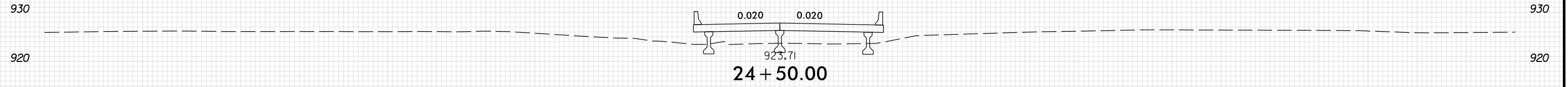
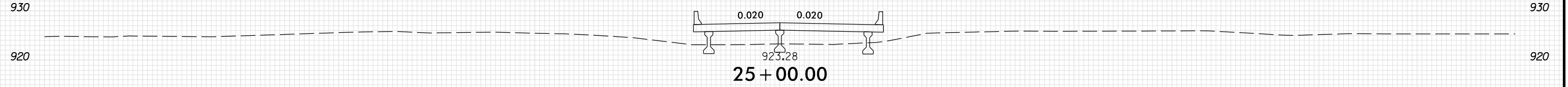

-Y16-

150 140 130 120 110 100 90 80 70 60 50 40 30 20 10 0 10 20 30 40 50 60 70 80 90 100 110 120 130 140 150

PLOT DRIVER: NCD01\_pdf\_color\_eng\_100.plt  
 USER: SPEREIRA  
 FILE: \

DATE: 6/10/2021  
 TIME: 2:30:06 PM

PENTABLE: xpl\_en\_v8.tbl

8/23/99

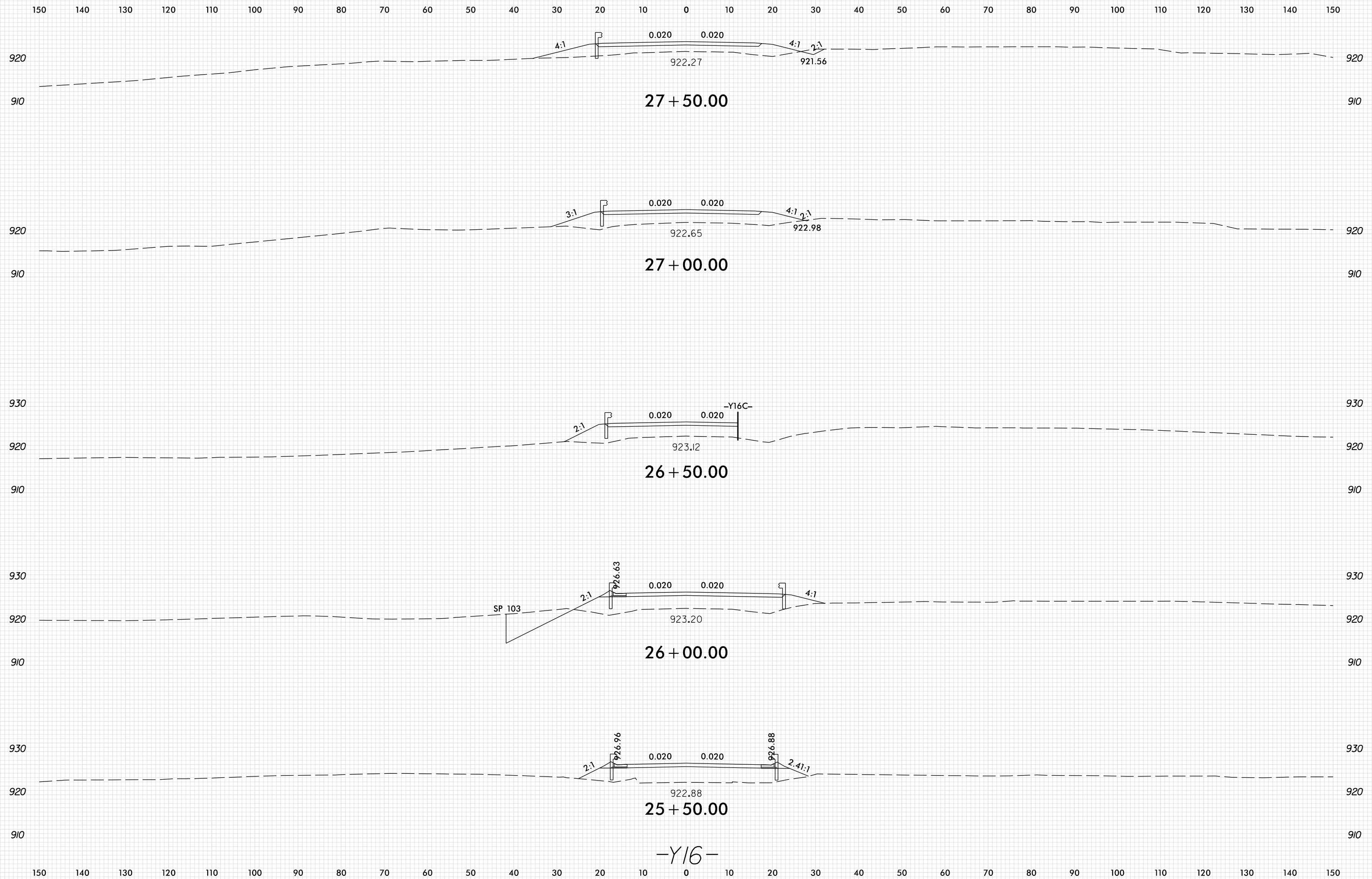

PLOT DRIVER: NCD01\_pdf\_color\_eng\_100.plt  
 USER: SPEREIRA  
 DATE: 6/10/2021  
 TIME: 2:30:07 PM  
 FILE: \

8/23/99



PROJ. REFERENCE NO.	SHEET NO.
U-2579AB	X-571

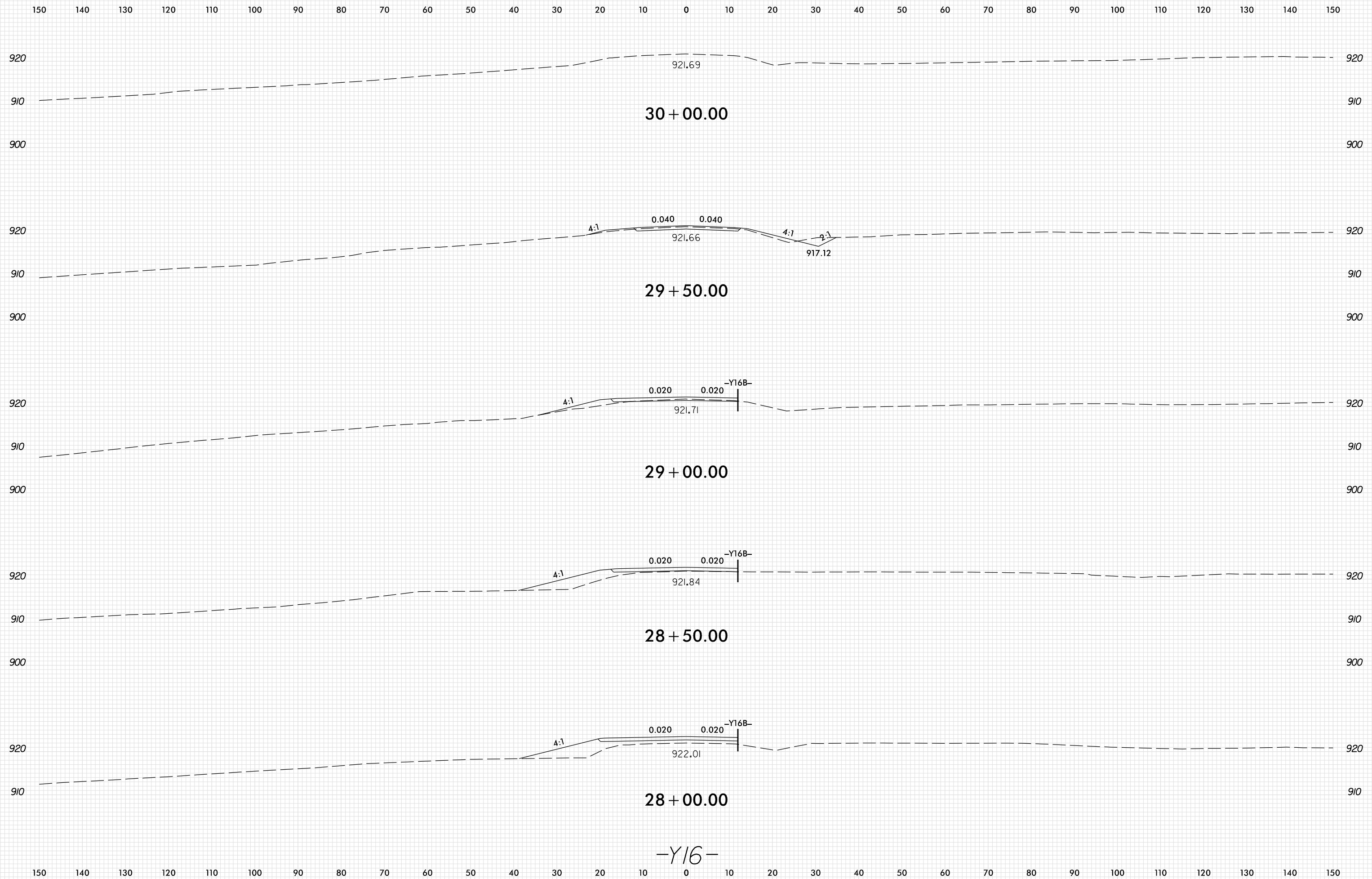

-Y16-

PLOT DRIVER: NCD01\_pdf\_color\_eng\_100.plt  
 USER: SPEREIRA  
 DATE: 6/10/2021  
 TIME: 2:30:07 PM  
 FILE: \

8/23/99



PROJ. REFERENCE NO.	SHEET NO.
U-2579AB	X-572

150 140 130 120 110 100 90 80 70 60 50 40 30 20 10 0 10 20 30 40 50 60 70 80 90 100 110 120 130 140 150

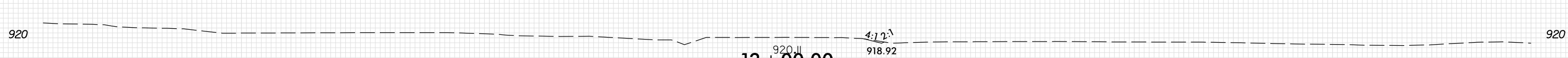
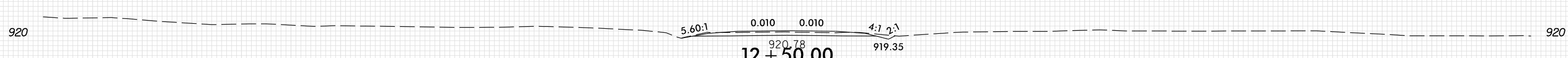
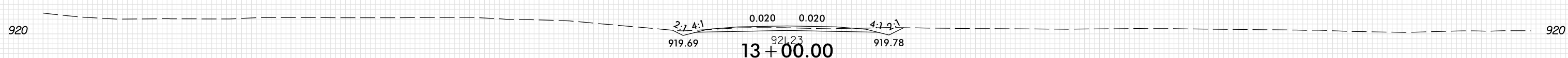
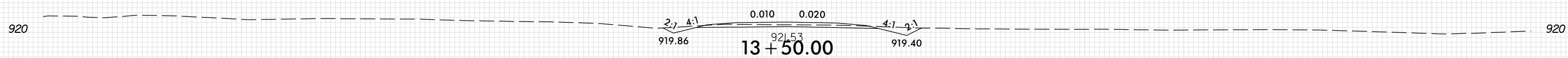
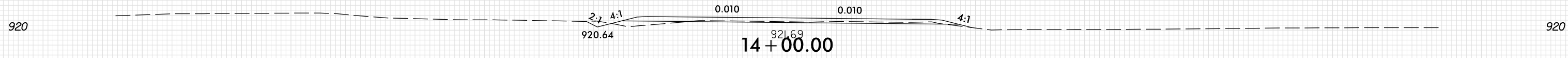

-Y16B-

150 140 130 120 110 100 90 80 70 60 50 40 30 20 10 0 10 20 30 40 50 60 70 80 90 100 110 120 130 140 150

PLOT DRIVER: NCD01\_pdf\_color\_eng\_100.plt  
USER: SPEREIRA  
DATE: 6/10/2021  
TIME: 2:30:15 PM  
FILE: \



8/23/99



PROJ. REFERENCE NO.	SHEET NO.
U-2579AB	X-573

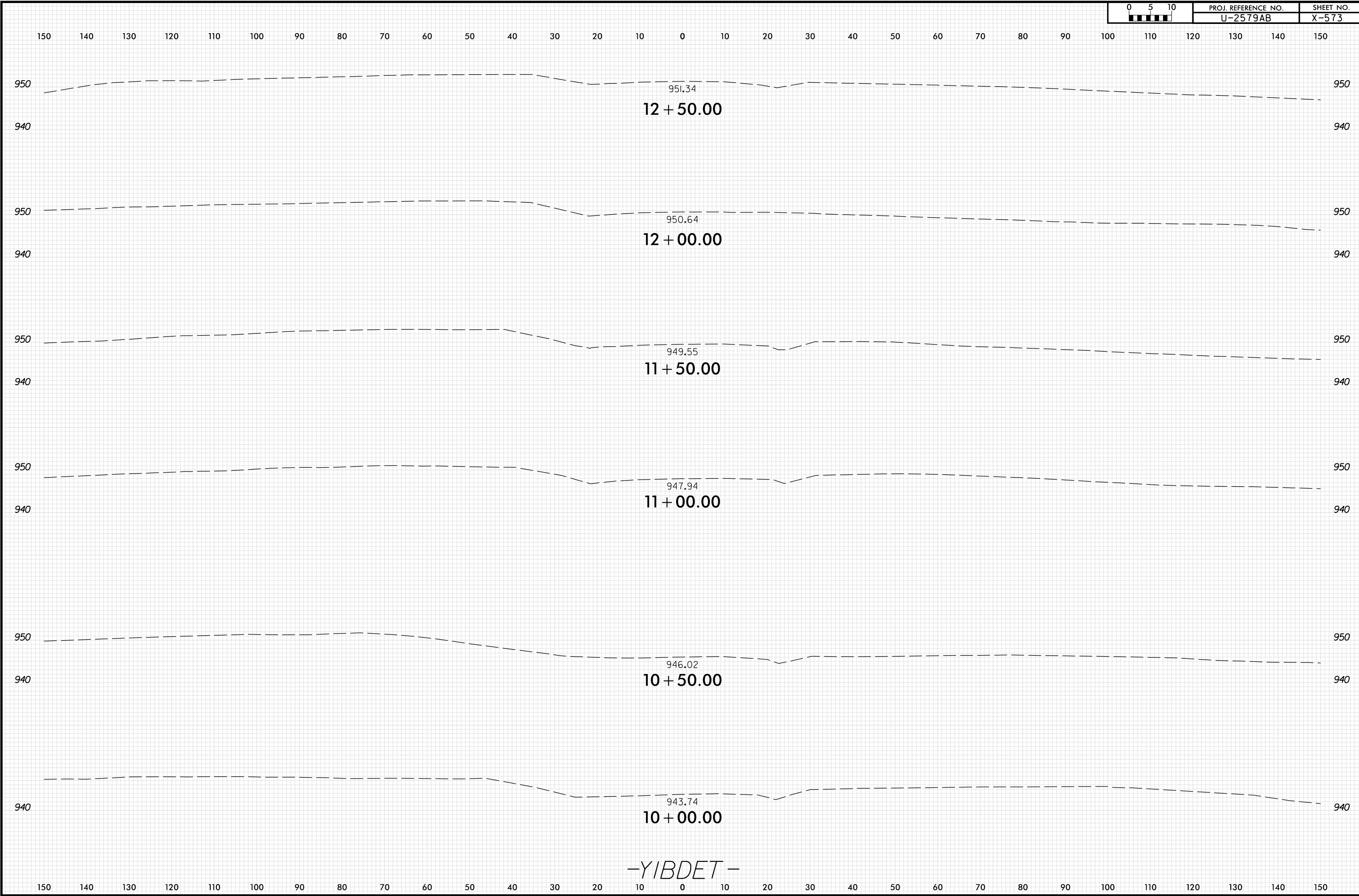

-YIBDET-

PLOT DRIVER: NCDOT\_pdf\_color\_eng\_100.plt  
 USER: SPEREIRA  
 FILE: \

DATE: 6/10/2021  
 TIME: 2:30:27 PM

PENTABLE: xpl\_en\_v8.tbl

8/23/99



PROJ. REFERENCE NO.	SHEET NO.
U-2579AB	X-574

150 140 130 120 110 100 90 80 70 60 50 40 30 20 10 0 10 20 30 40 50 60 70 80 90 100 110 120 130 140 150

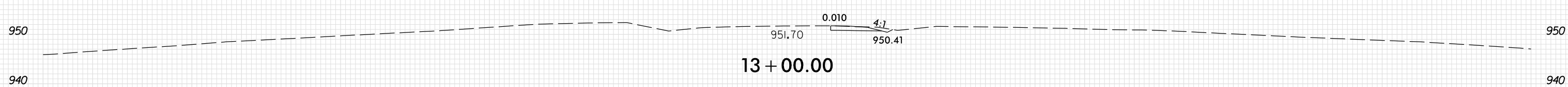
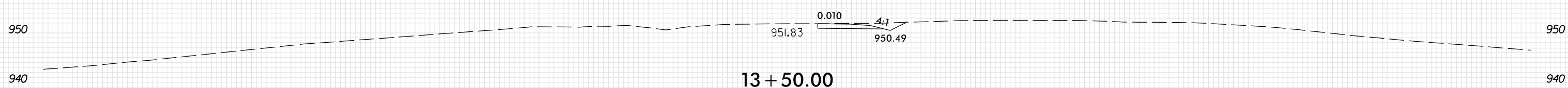
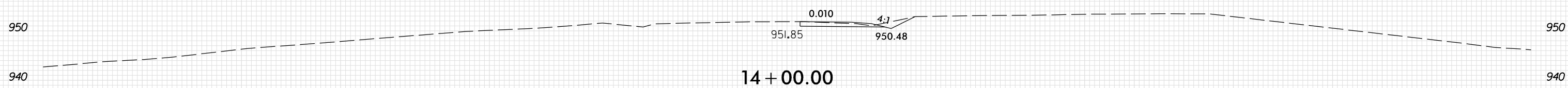
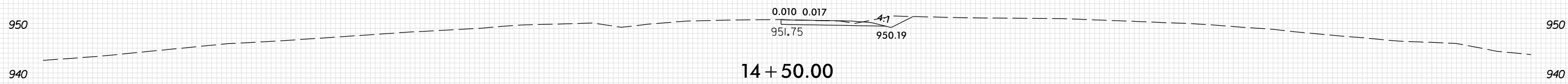
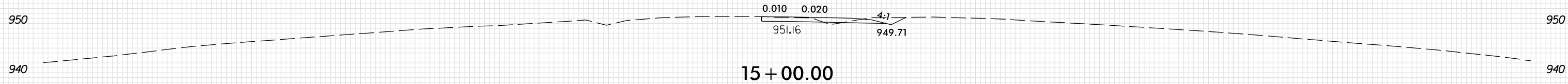

-YIBDET-

150 140 130 120 110 100 90 80 70 60 50 40 30 20 10 0 10 20 30 40 50 60 70 80 90 100 110 120 130 140 150

PLOT DRIVER: NCD01\_pdf\_color\_eng\_100.plt  
 USER: SPEREIRA  
 DATE: 6/10/2021  
 TIME: 2:30:28 PM  
 FILE: \

8/23/99



PROJ. REFERENCE NO.	SHEET NO.
U-2579AB	X-575

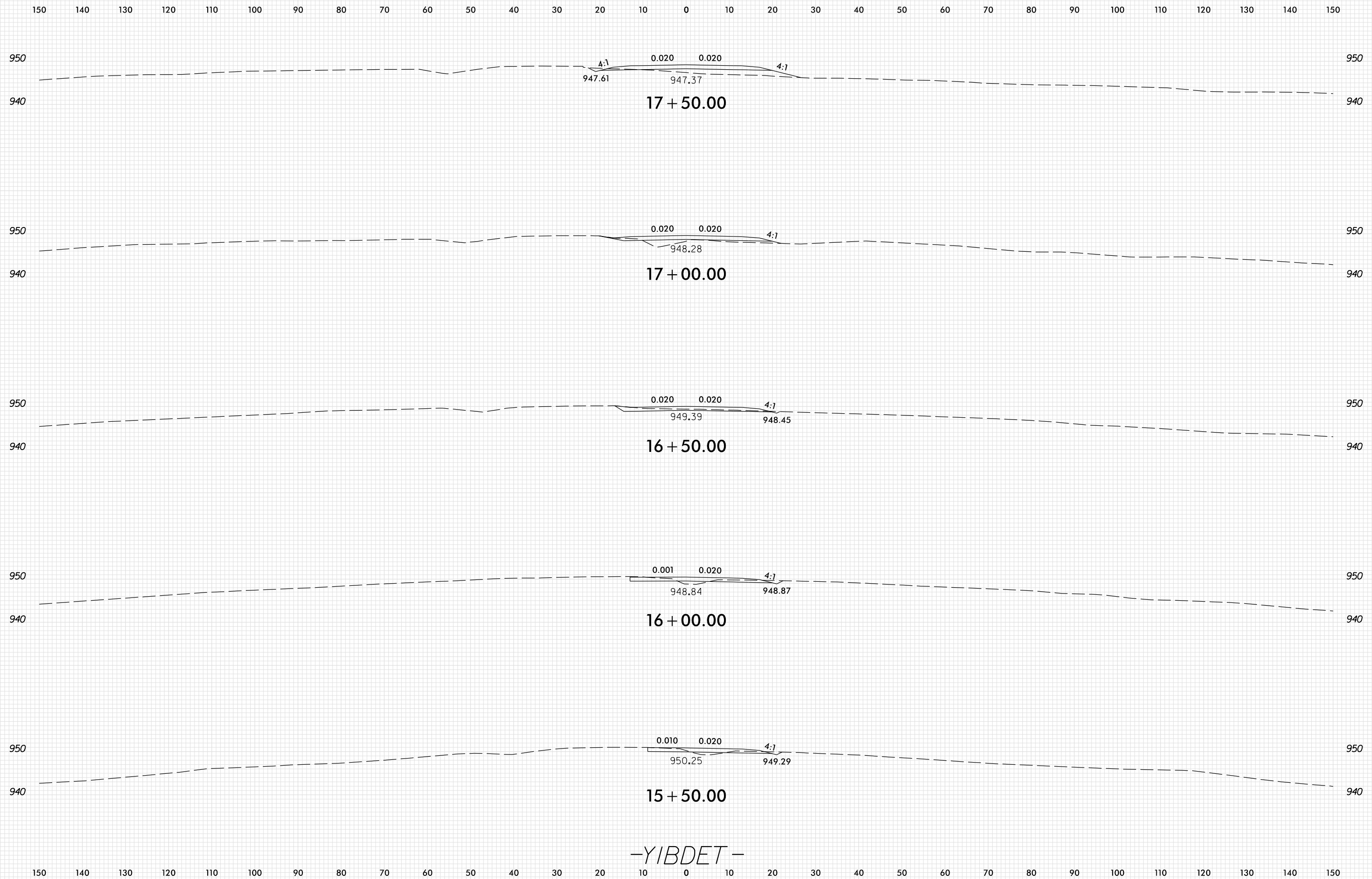

-YIBDET-

PLOT DRIVER: NCD01\_pdf\_color\_eng\_100.plt  
 USER: SPEREIRA  
 DATE: 6/10/2021  
 TIME: 2:30:28 PM  
 FILE: \

8/23/99

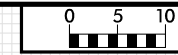

PROJ. REFERENCE NO.	SHEET NO.
U-2579AB	X-576

150 140 130 120 110 100 90 80 70 60 50 40 30 20 10 0 10 20 30 40 50 60 70 80 90 100 110 120 130 140 150

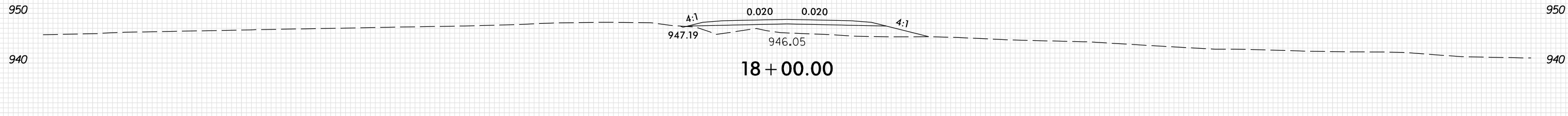
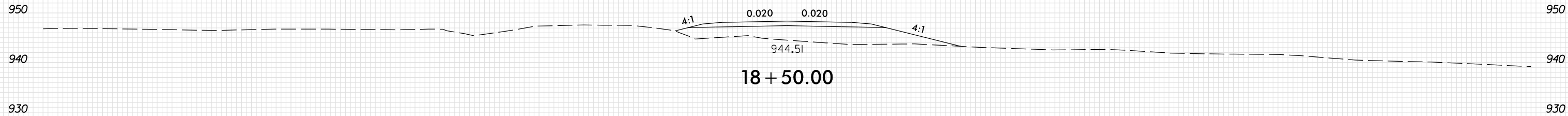
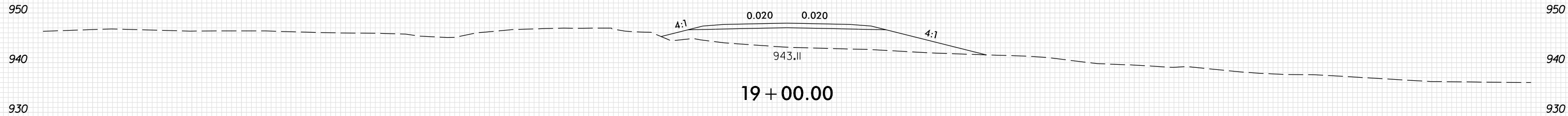
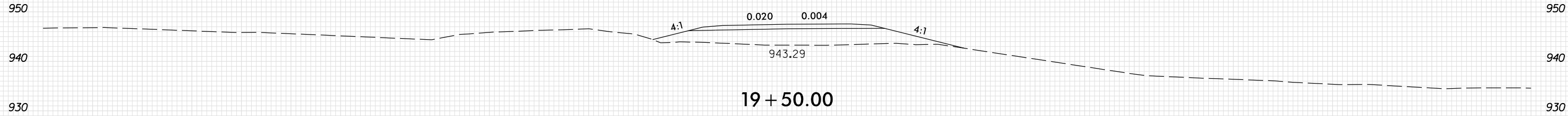

-YIBDET-

150 140 130 120 110 100 90 80 70 60 50 40 30 20 10 0 10 20 30 40 50 60 70 80 90 100 110 120 130 140 150

PLOT DRIVER: NCDOT\_pdf\_color\_eng\_100.plt  
 USER: SPEREIRA  
 DATE: 6/10/2021  
 TIME: 2:30:29 PM  
 FILE: \

8/23/99

0 5 10	PROJ. REFERENCE NO.	SHEET NO.
	U-2579AB	X-577

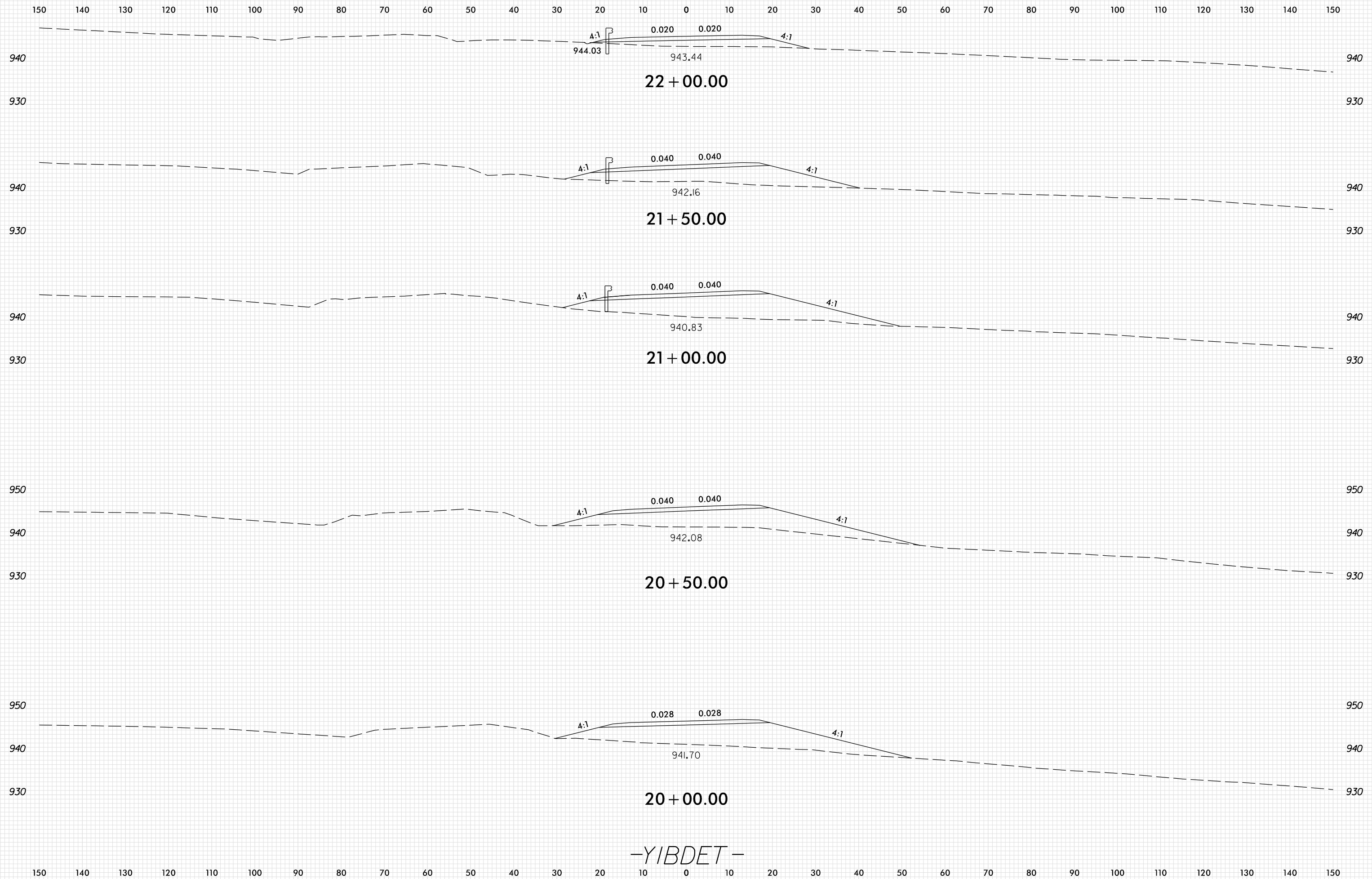

-YIBDET-

PLOT DRIVER: NCD01\_pdf\_color\_eng\_100.plt  
 USER: SPEREIRA  
 DATE: 6/10/2021  
 TIME: 2:30:30 PM  
 FILE: \

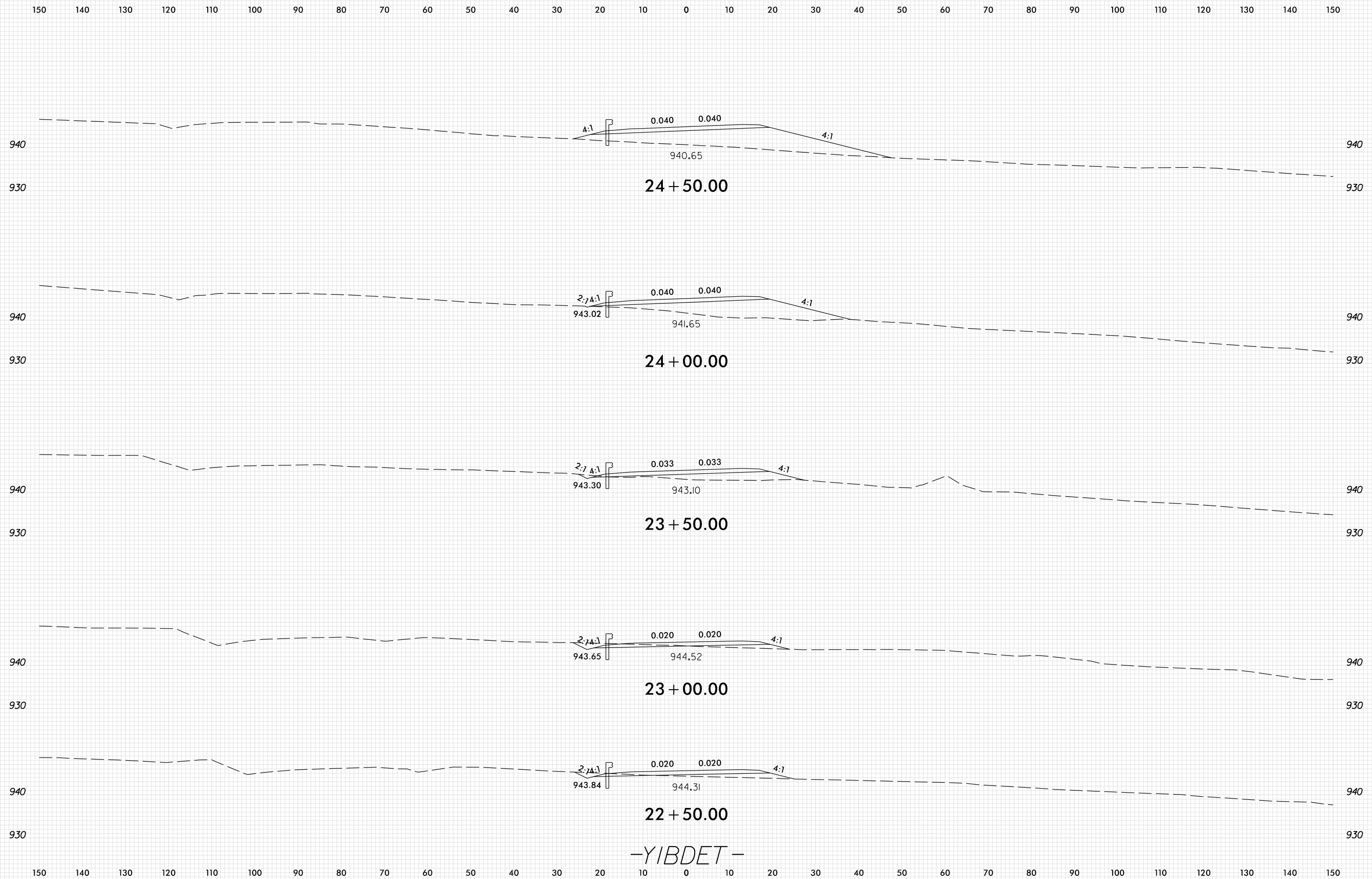

-YIBDET-

8/23/99

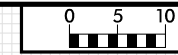

PROJ. REFERENCE NO.	SHEET NO.
U-2579AB	X-579

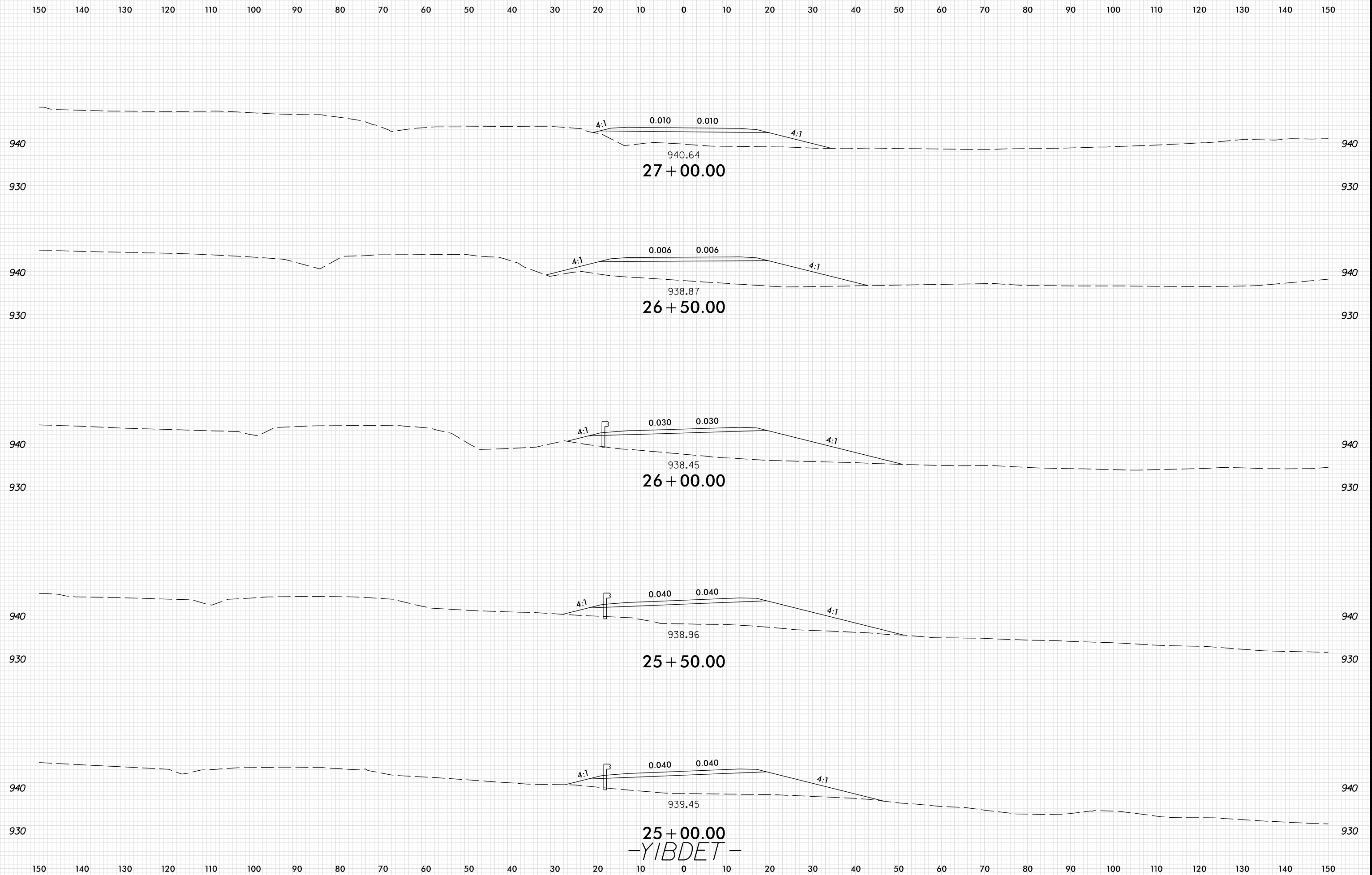

25 + 00.00  
-YIBDET-

PLOT DRIVER: NCD01\_pdf\_color\_eng\_100.plt  
 USER: SPEREIRA  
 DATE: 6/10/2021  
 TIME: 2:30:31 PM  
 FILE: \

8/23/99



PROJ. REFERENCE NO.	SHEET NO.
U-2579AB	X-580

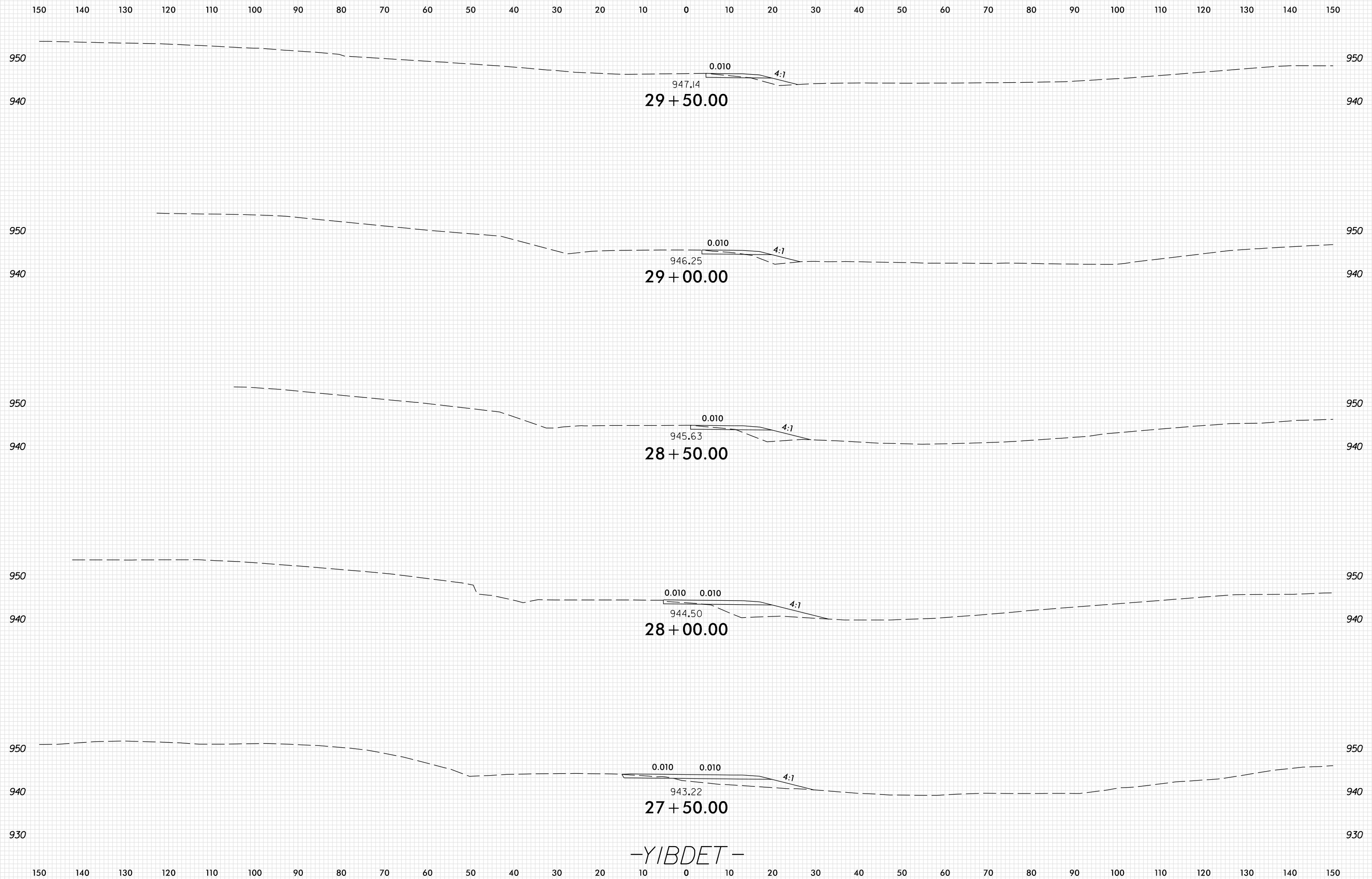

-YIBDET-

PLOT DRIVER: NCD01\_pdf\_color\_eng\_100.plt  
 USER: SPEREIRA  
 DATE: 6/10/2021  
 TIME: 2:30:31 PM  
 FILE: \



8/23/99

0 5 10	PROJ. REFERENCE NO.	SHEET NO.
	U-2579AB	X-581

150 140 130 120 110 100 90 80 70 60 50 40 30 20 10 0 10 20 30 40 50 60 70 80 90 100 110 120 130 140 150

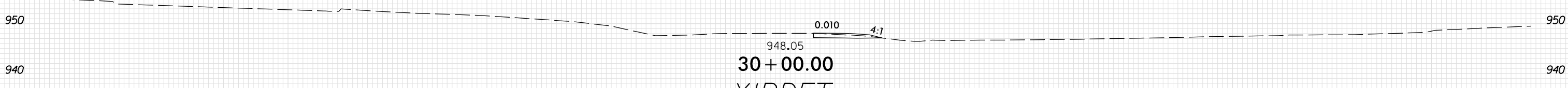
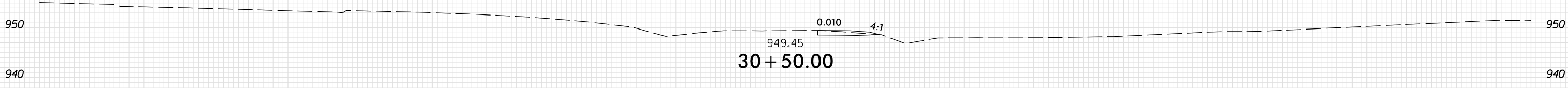
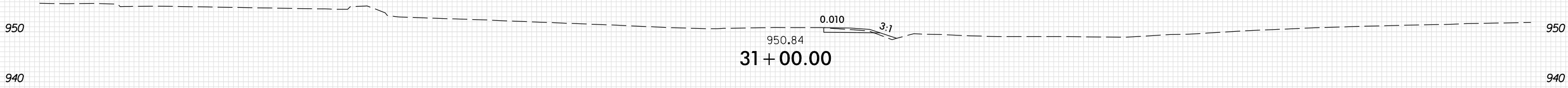

-YIBDET-

150 140 130 120 110 100 90 80 70 60 50 40 30 20 10 0 10 20 30 40 50 60 70 80 90 100 110 120 130 140 150

PLOT DRIVER: NCD01\_pdf\_color\_eng\_100.plt  
 USER: SPEREIRA  
 DATE: 6/10/2021  
 TIME: 2:30:32 PM  
 FILE: \

8/23/99

150 140 130 120 110 100 90 80 70 60 50 40 30 20 10 0 10 20 30 40 50 60 70 80 90 100 110 120 130 140 150

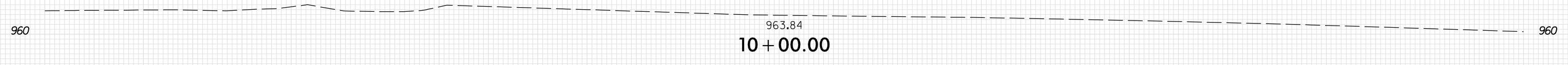
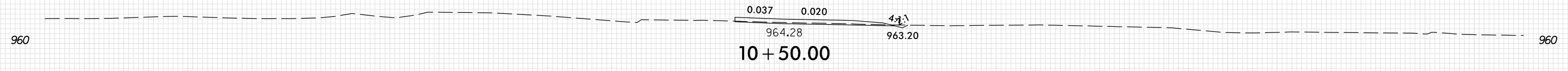
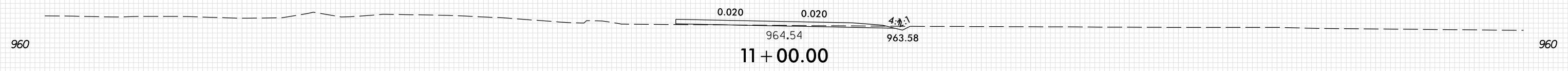
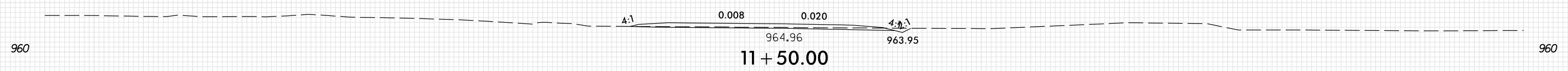
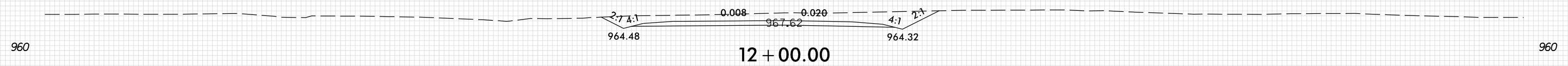
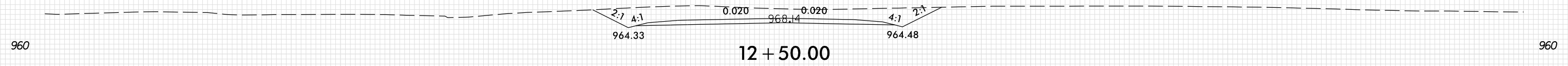

-Y4DET-

150 140 130 120 110 100 90 80 70 60 50 40 30 20 10 0 10 20 30 40 50 60 70 80 90 100 110 120 130 140 150

PLOT DRIVER: NCD01\_pdf\_color\_eng\_100.plt  
 USER: SPEREIRA  
 DATE: 6/10/2021  
 TIME: 2:30:46 PM  
 FILE: \

8/23/99

0 5 10	PROJ. REFERENCE NO.	SHEET NO.
	U-2579AB	X-583

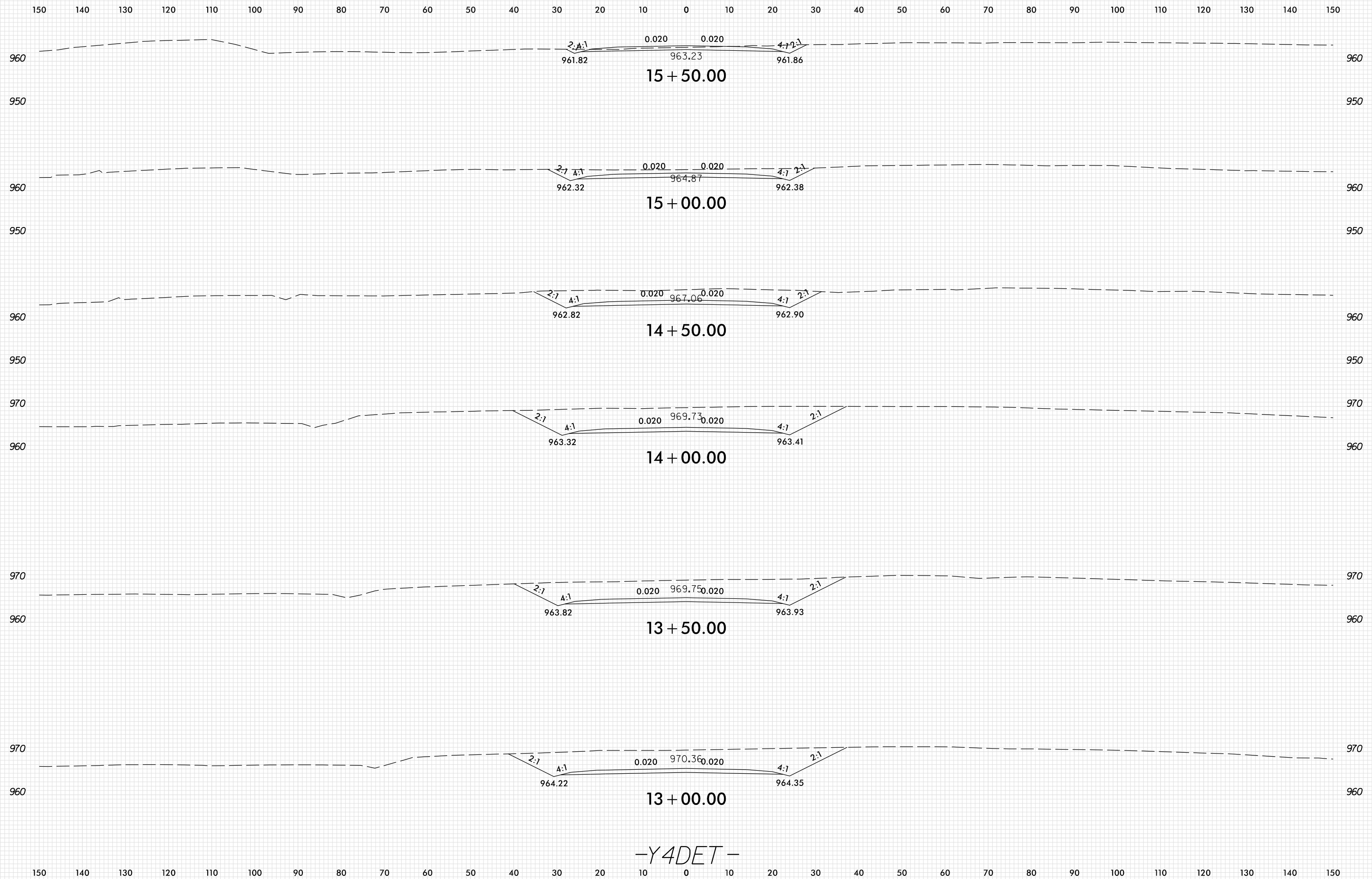

-Y4DET-

PLOT DRIVER: NCD01\_pdf\_color\_eng\_100.plt  
 USER: SPEREIRA  
 DATE: 6/10/2021  
 TIME: 2:30:46 PM

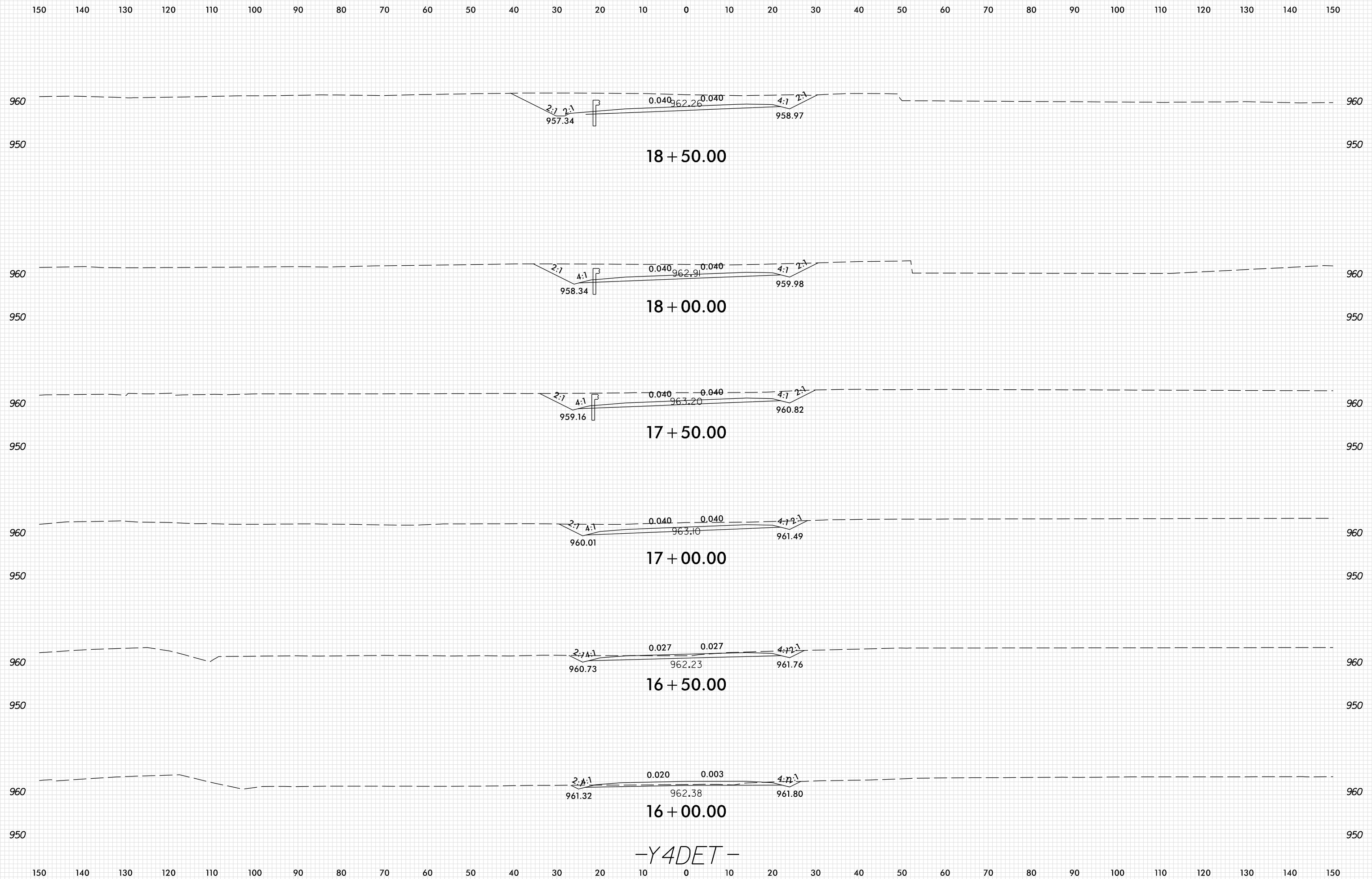

-Y4DET-

8/23/99



PROJ. REFERENCE NO.	SHEET NO.
U-2579AB	X-585

150 140 130 120 110 100 90 80 70 60 50 40 30 20 10 0 10 20 30 40 50 60 70 80 90 100 110 120 130 140 150

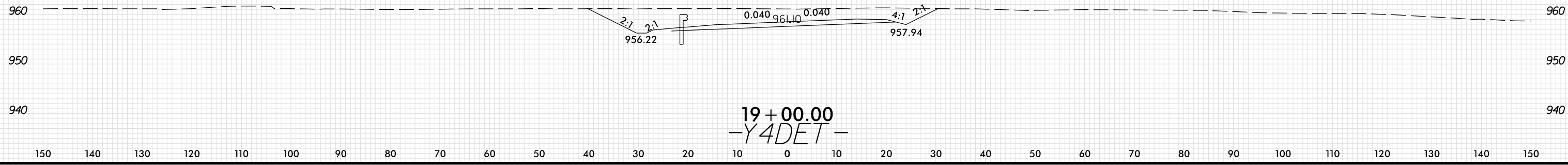
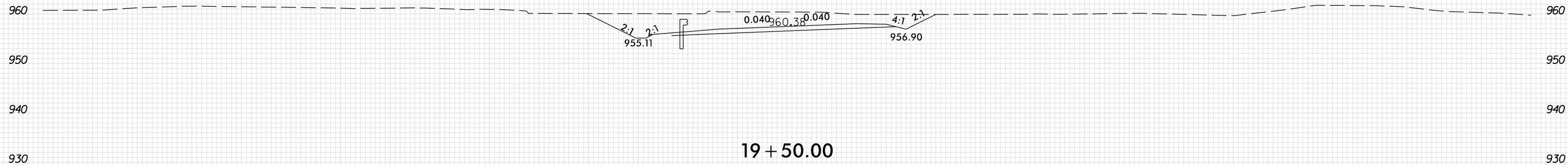
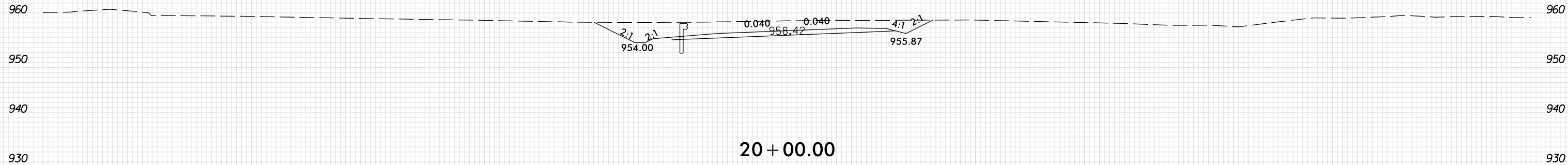

150 140 130 120 110 100 90 80 70 60 50 40 30 20 10 0 10 20 30 40 50 60 70 80 90 100 110 120 130 140 150

8/23/99

0 5 10	PROJ. REFERENCE NO.	SHEET NO.
	U-2579AB	X-586

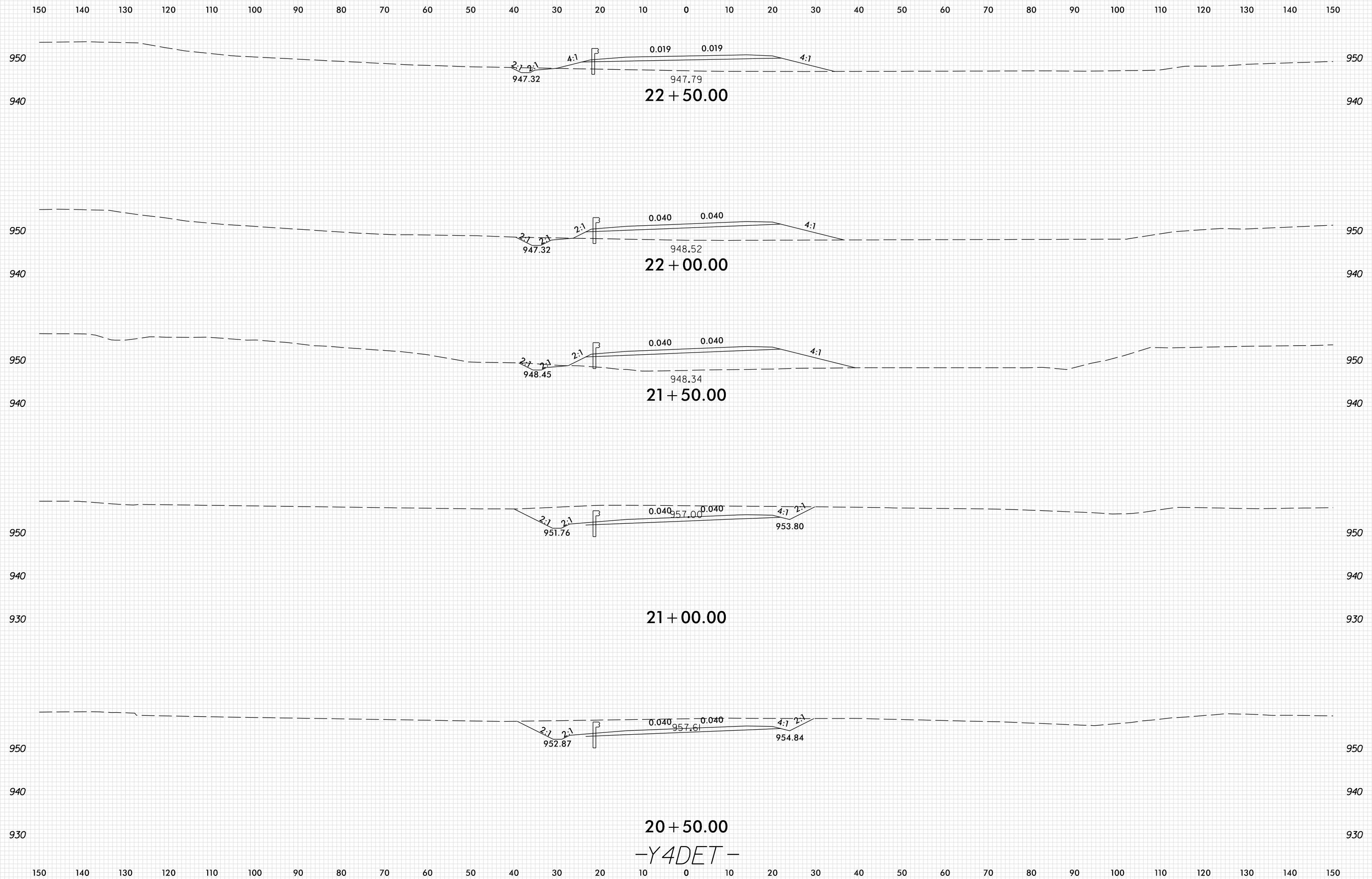

20 + 50.00  
-Y4DET-

PLOT DRIVER: NCDOT\_pdf\_color\_eng\_100.plt  
USER: SPEREIRA  
DATE: 6/10/2021  
TIME: 2:30:48 PM  
FILE: \

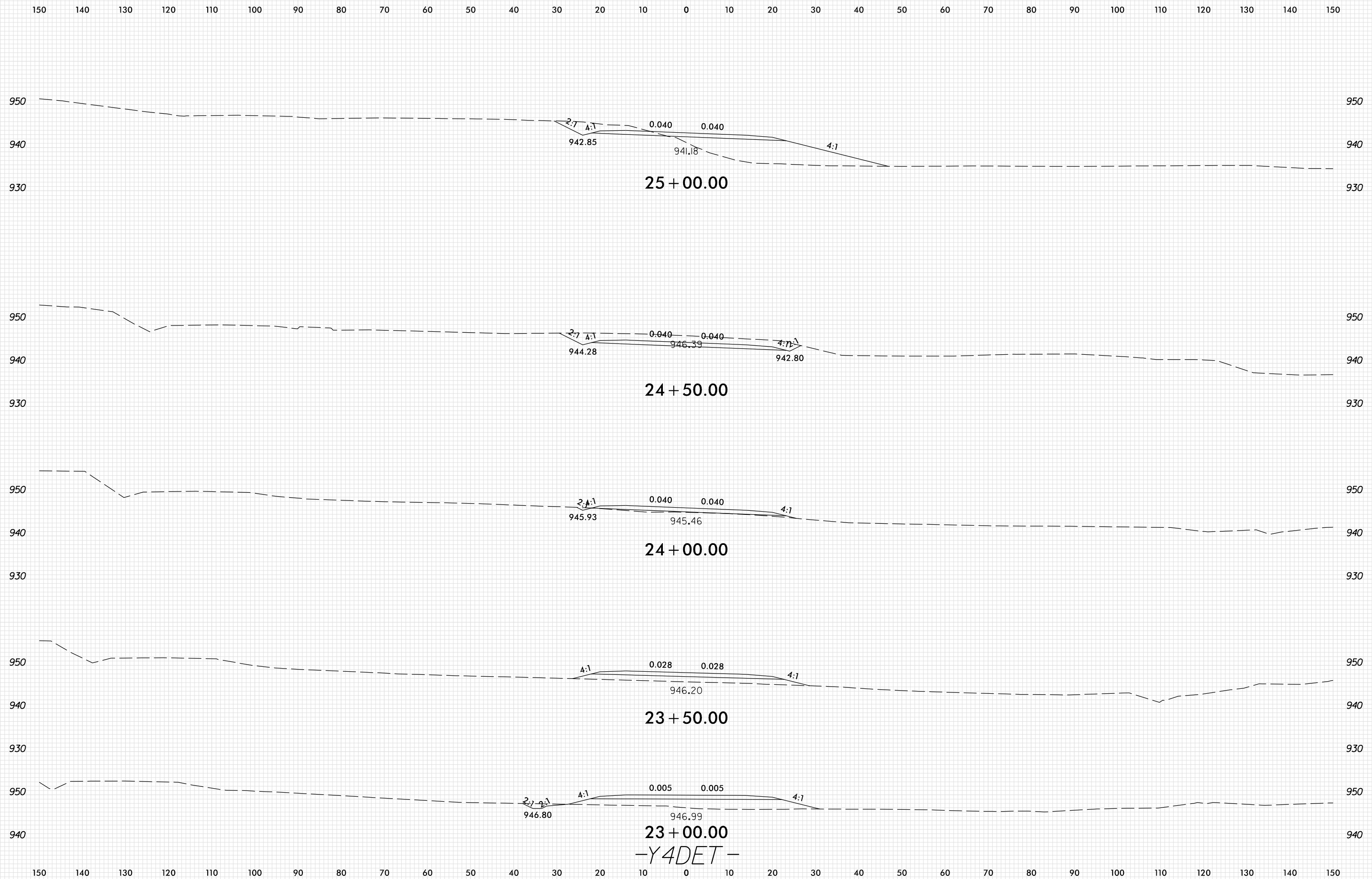

23+00.00  
-Y4DET-

8/23/99

0 5 10	PROJ. REFERENCE NO.	SHEET NO.
	U-2579AB	X-588

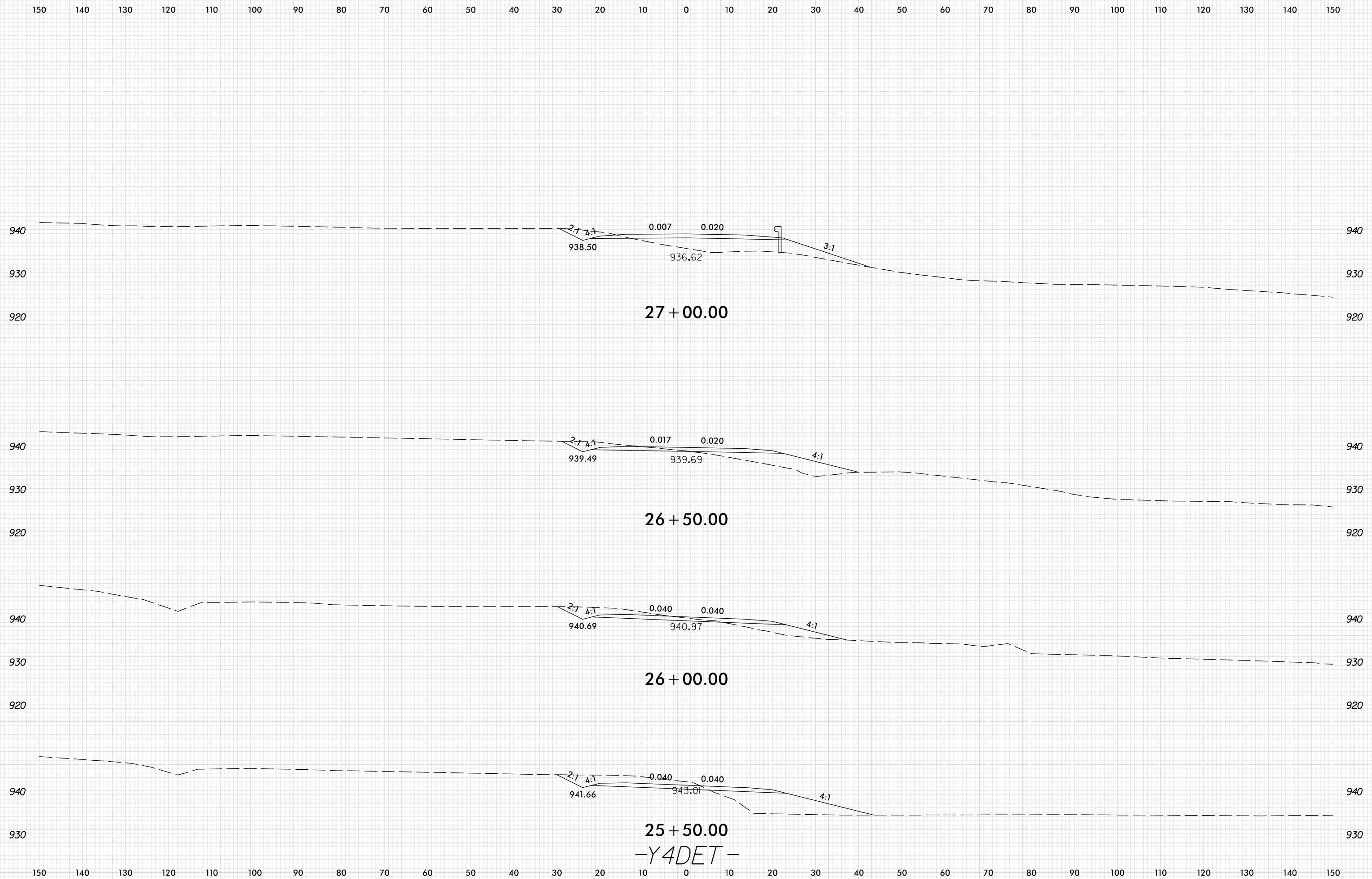

PLOT DRIVER: NCDOT\_pdf\_color\_eng\_100.plt  
 USER: SPEREIRA  
 DATE: 6/10/2021  
 TIME: 2:30:49 PM  
 FILE: \

25+50.00  
 -Y4DET-



8/23/99



PROJ. REFERENCE NO.	SHEET NO.
U-2579AB	X-589

150 140 130 120 110 100 90 80 70 60 50 40 30 20 10 0 10 20 30 40 50 60 70 80 90 100 110 120 130 140 150

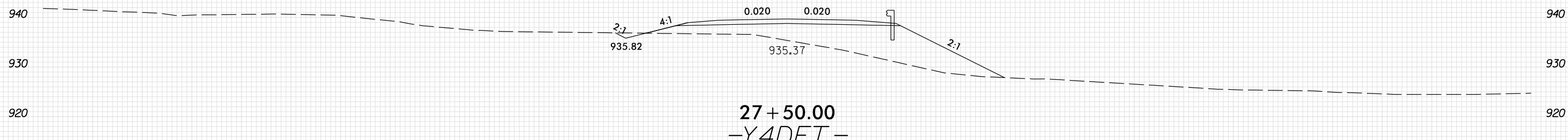
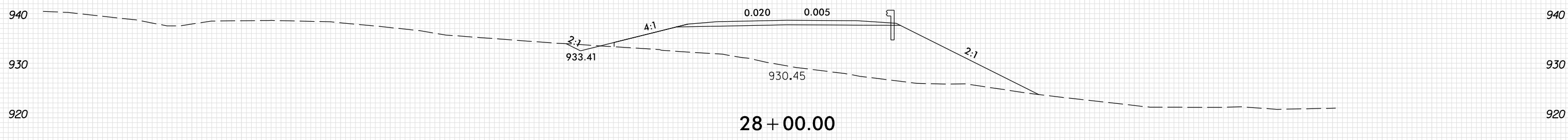
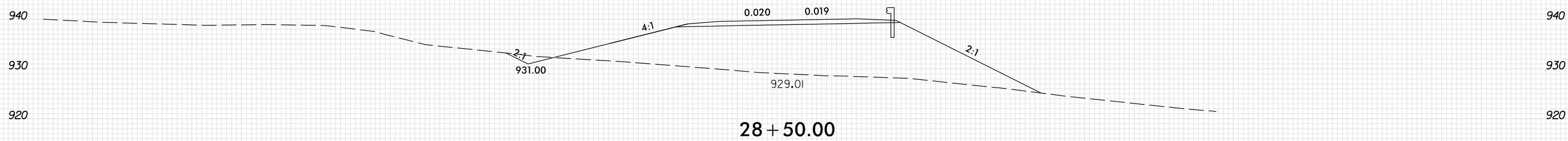
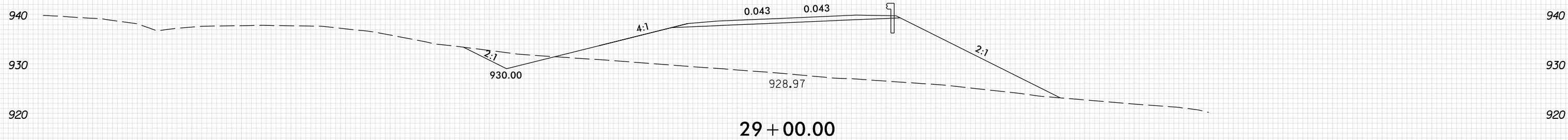

-Y4DET-

PLOT DRIVER: NCDOT\_pdf\_color\_eng\_100.plt  
 USER: SPEREIRA  
 DATE: 6/10/2021  
 TIME: 2:30:50 PM  
 FILE: \

8/23/99

0 5 10	PROJ. REFERENCE NO.	SHEET NO.
	U-2579AB	X-590

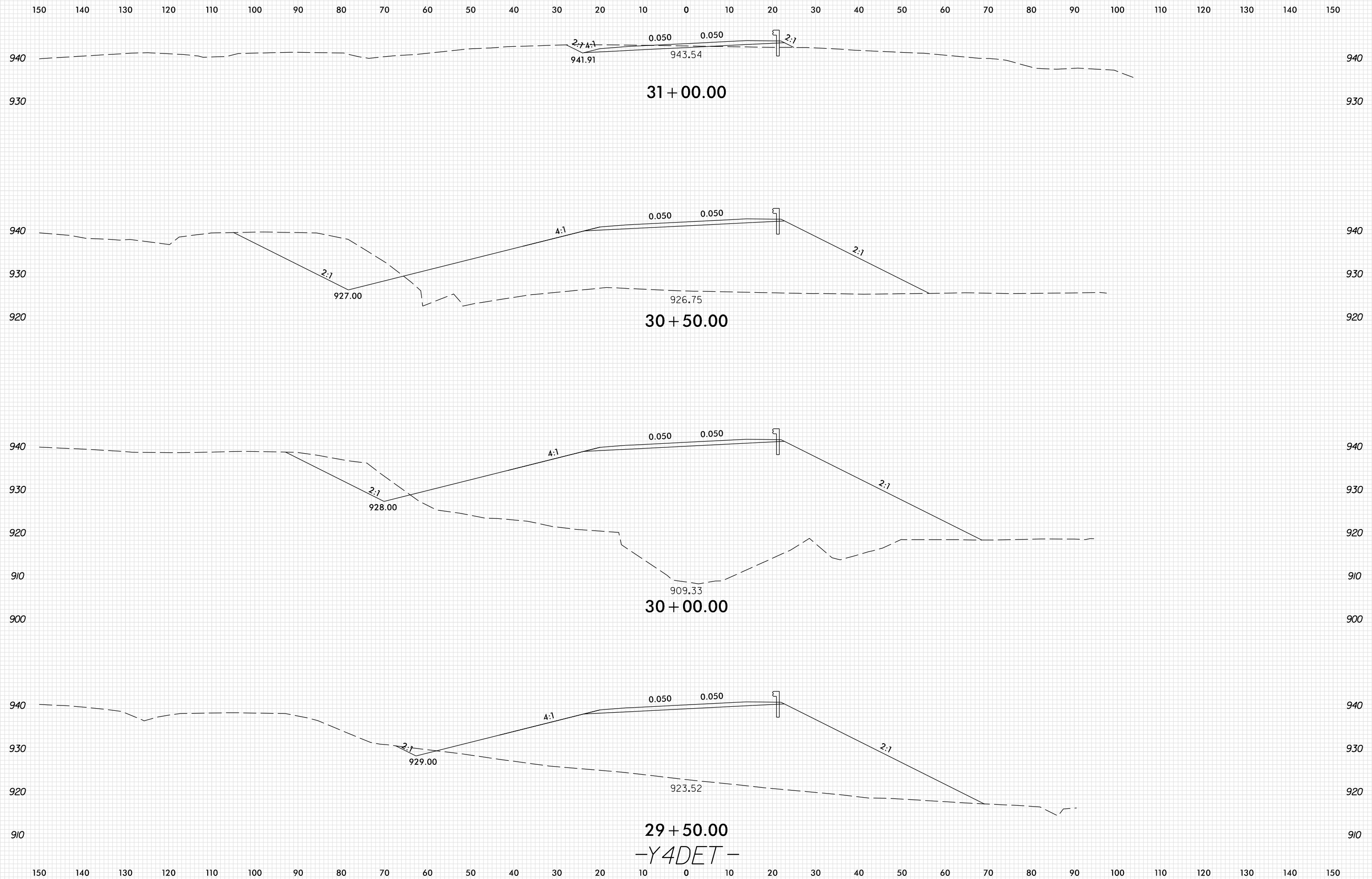

PLOT DRIVER: NCDOT\_pdf\_color\_eng\_100.plt  
 USER: SPEREIRA  
 DATE: 6/10/2021  
 TIME: 2:30:51 PM  
 FILE: \

29+50.00  
 -Y4DET-

8/23/99



PROJ. REFERENCE NO.	SHEET NO.
U-2579AB	X-591

150 140 130 120 110 100 90 80 70 60 50 40 30 20 10 0 10 20 30 40 50 60 70 80 90 100 110 120 130 140 150

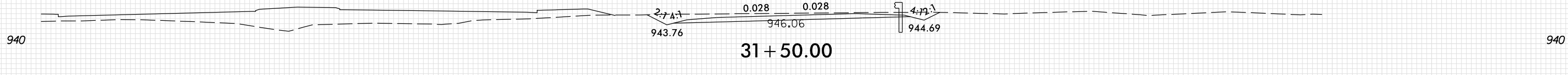
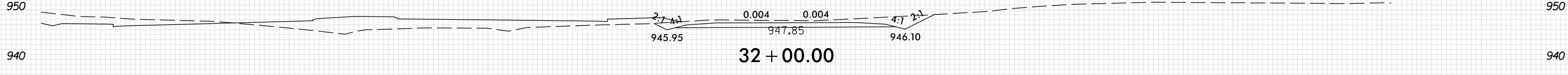
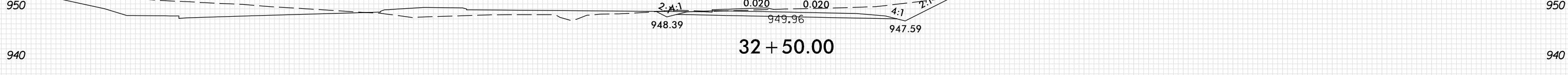
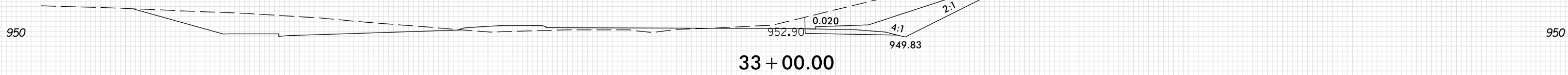
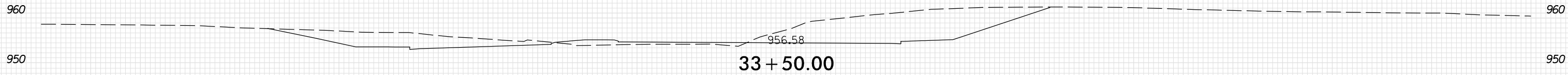

-Y4DET-

150 140 130 120 110 100 90 80 70 60 50 40 30 20 10 0 10 20 30 40 50 60 70 80 90 100 110 120 130 140 150

PLOT DRIVER: NCDOT\_pdf\_color\_eng\_100.plt  
 USER: SPEREIRA  
 DATE: 6/10/2021  
 TIME: 2:30:51 PM  
 FILE: \

8/23/99

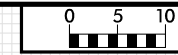

PROJ. REFERENCE NO.	SHEET NO.
U-2579AB	X-592

150 140 130 120 110 100 90 80 70 60 50 40 30 20 10 0 10 20 30 40 50 60 70 80 90 100 110 120 130 140 150

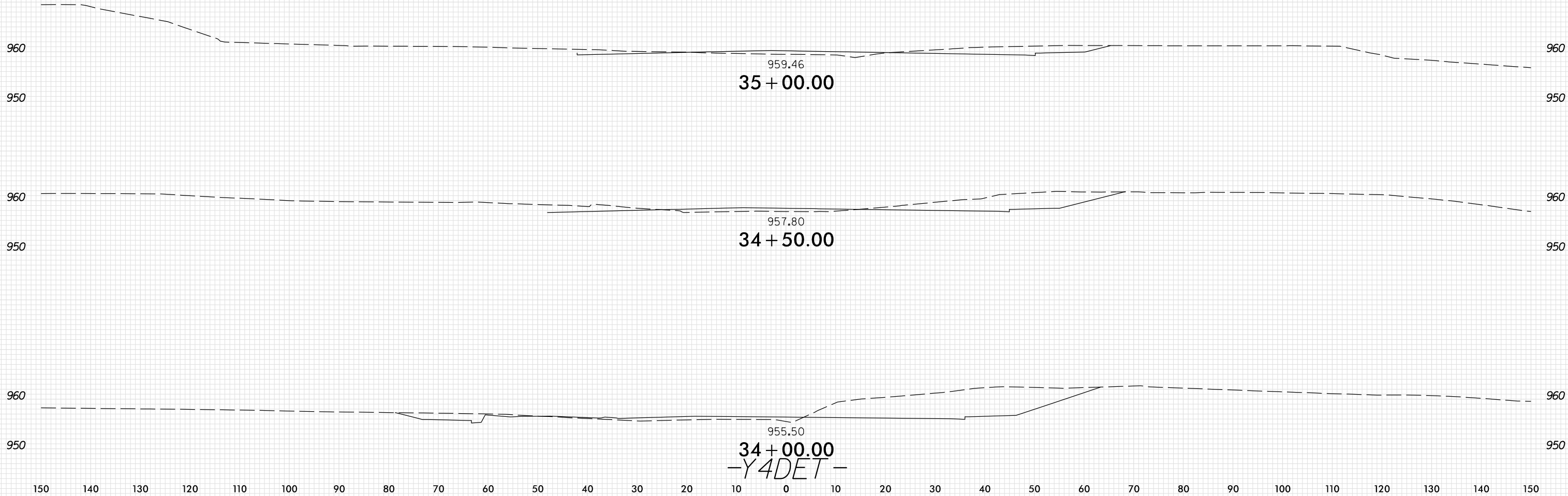

PLOT DRIVER: NCDOT\_pdf\_color\_eng\_100.plt  
 USER: SPEREIRA  
 DATE: 6/10/2021  
 TIME: 2:30:52 PM  
 FILE: \

8/23/99



PROJ. REFERENCE NO.	SHEET NO.
U-2579AB	X-593

150 140 130 120 110 100 90 80 70 60 50 40 30 20 10 0 10 20 30 40 50 60 70 80 90 100 110 120 130 140 150

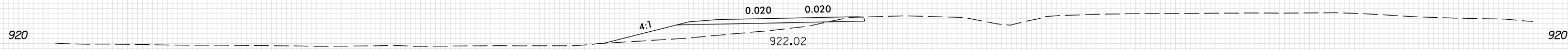

15 + 00.00

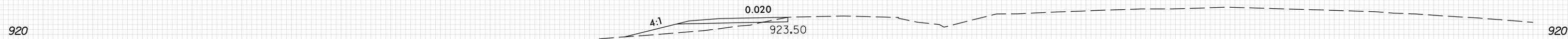

14 + 50.00

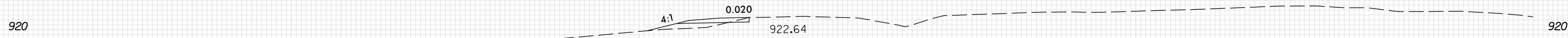

14 + 00.00

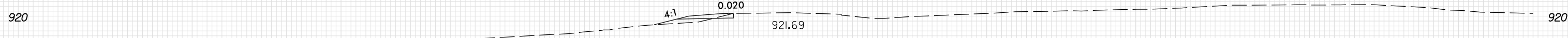

13 + 50.00

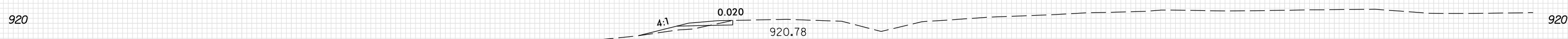

13 + 00.00

-Y16DET-

150 140 130 120 110 100 90 80 70 60 50 40 30 20 10 0 10 20 30 40 50 60 70 80 90 100 110 120 130 140 150

PLOT DRIVER: NCD01\_pdf\_color\_eng\_100.plt  
 USER: SPEREIRA  
 DATE: 6/10/2021  
 TIME: 2:31:04 PM  
 FILE: \

8/23/99



PROJ. REFERENCE NO.	SHEET NO.
U-2579AB	X-594

150 140 130 120 110 100 90 80 70 60 50 40 30 20 10 0 10 20 30 40 50 60 70 80 90 100 110 120 130 140 150

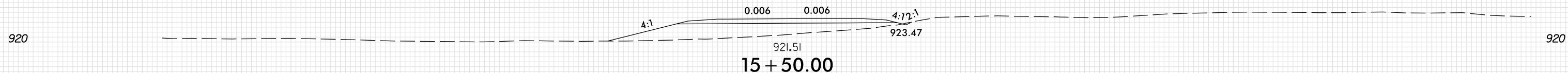
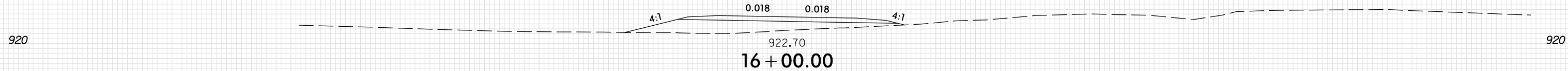
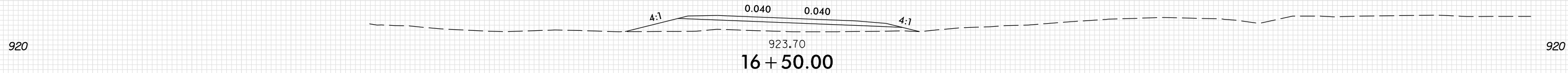
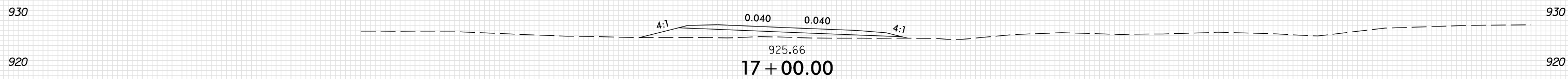
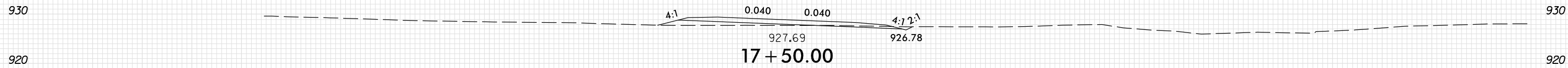

-Y16DET-

150 140 130 120 110 100 90 80 70 60 50 40 30 20 10 0 10 20 30 40 50 60 70 80 90 100 110 120 130 140 150

PLOT DRIVER: NCD01\_pdf\_color\_eng\_100.plt  
 USER: SPEREIRA  
 DATE: 6/10/2021  
 TIME: 2:31:05 PM  
 FILE: \

8/23/99

0 5 10	PROJ. REFERENCE NO.	SHEET NO.
	U-2579AB	X-595

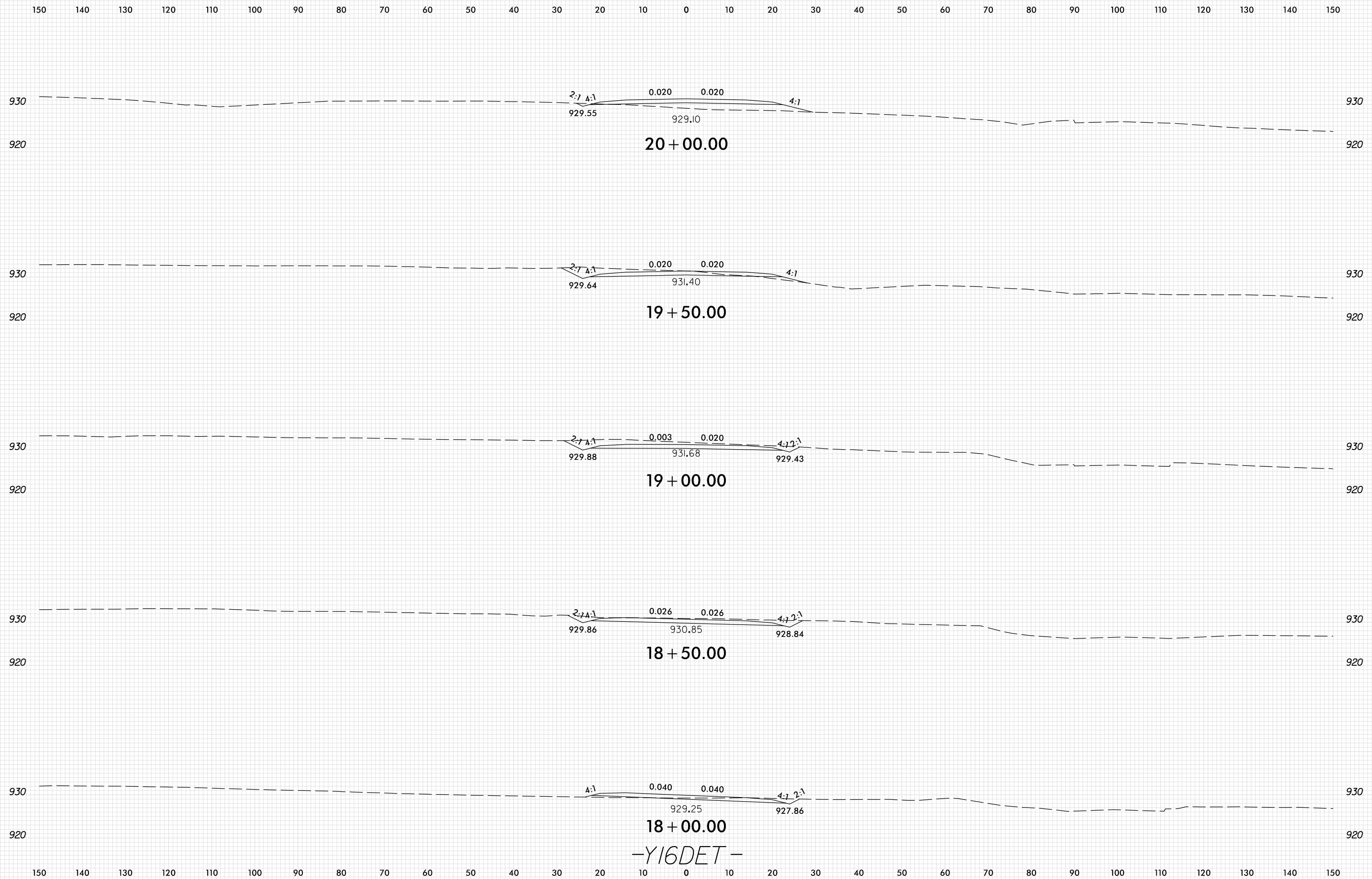

-Y16DET-

PLOT DRIVER: NCDOT\_pdf\_color\_eng\_100.plt  
 USER: SPEREIRA  
 DATE: 6/10/2021  
 TIME: 2:31:06 PM  
 FILE: \

8/23/99



PROJ. REFERENCE NO.	SHEET NO.
U-2579AB	X-596

150 140 130 120 110 100 90 80 70 60 50 40 30 20 10 0 10 20 30 40 50 60 70 80 90 100 110 120 130 140 150

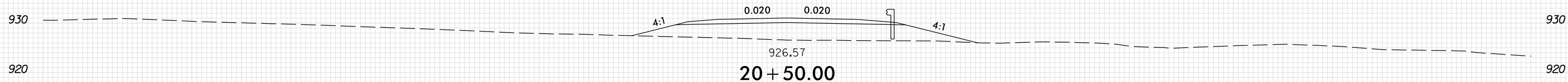
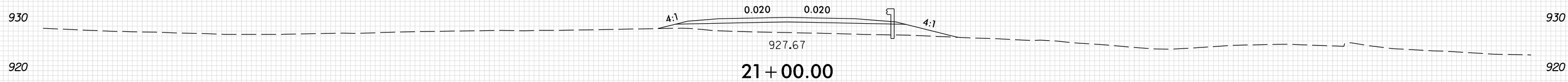
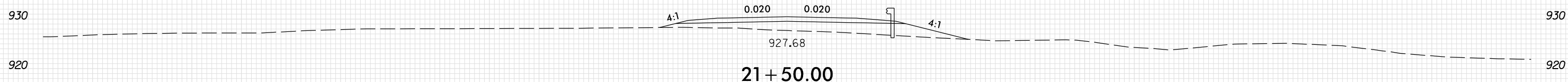
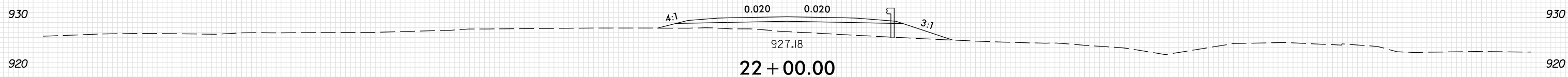
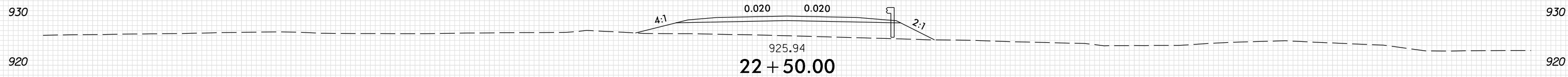

-Y16DET-

150 140 130 120 110 100 90 80 70 60 50 40 30 20 10 0 10 20 30 40 50 60 70 80 90 100 110 120 130 140 150

PLOT DRIVER: NCDOT\_pdf\_color\_eng\_100.plt  
USER: SPEREIRA  
DATE: 6/10/2021  
TIME: 2:31:06 PM  
FILE: \



8/23/99



PROJ. REFERENCE NO.	SHEET NO.
U-2579AB	X-597

150 140 130 120 110 100 90 80 70 60 50 40 30 20 10 0 10 20 30 40 50 60 70 80 90 100 110 120 130 140 150

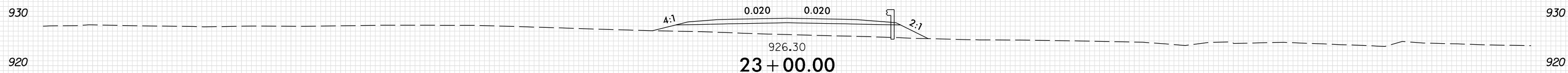
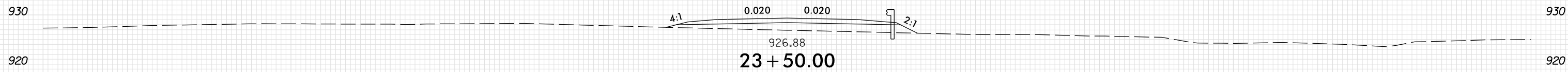
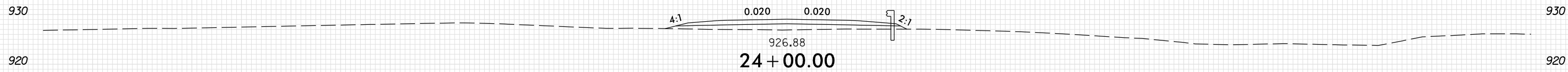
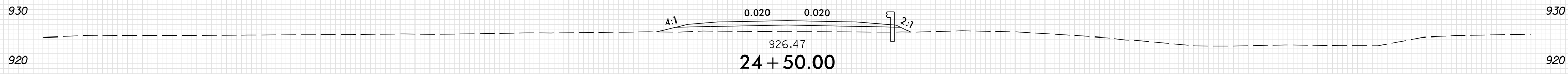
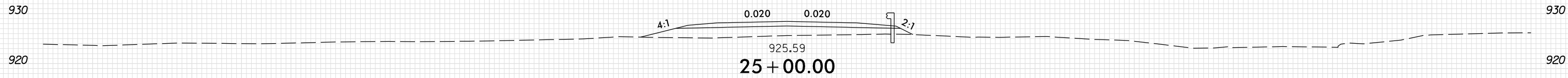

-Y16DET-

150 140 130 120 110 100 90 80 70 60 50 40 30 20 10 0 10 20 30 40 50 60 70 80 90 100 110 120 130 140 150

PLOT DRIVER: NCDOT\_pdf\_color\_eng\_100.plt  
 USER: SPEREIRA  
 DATE: 6/10/2021  
 TIME: 2:31:07 PM  
 FILE: \

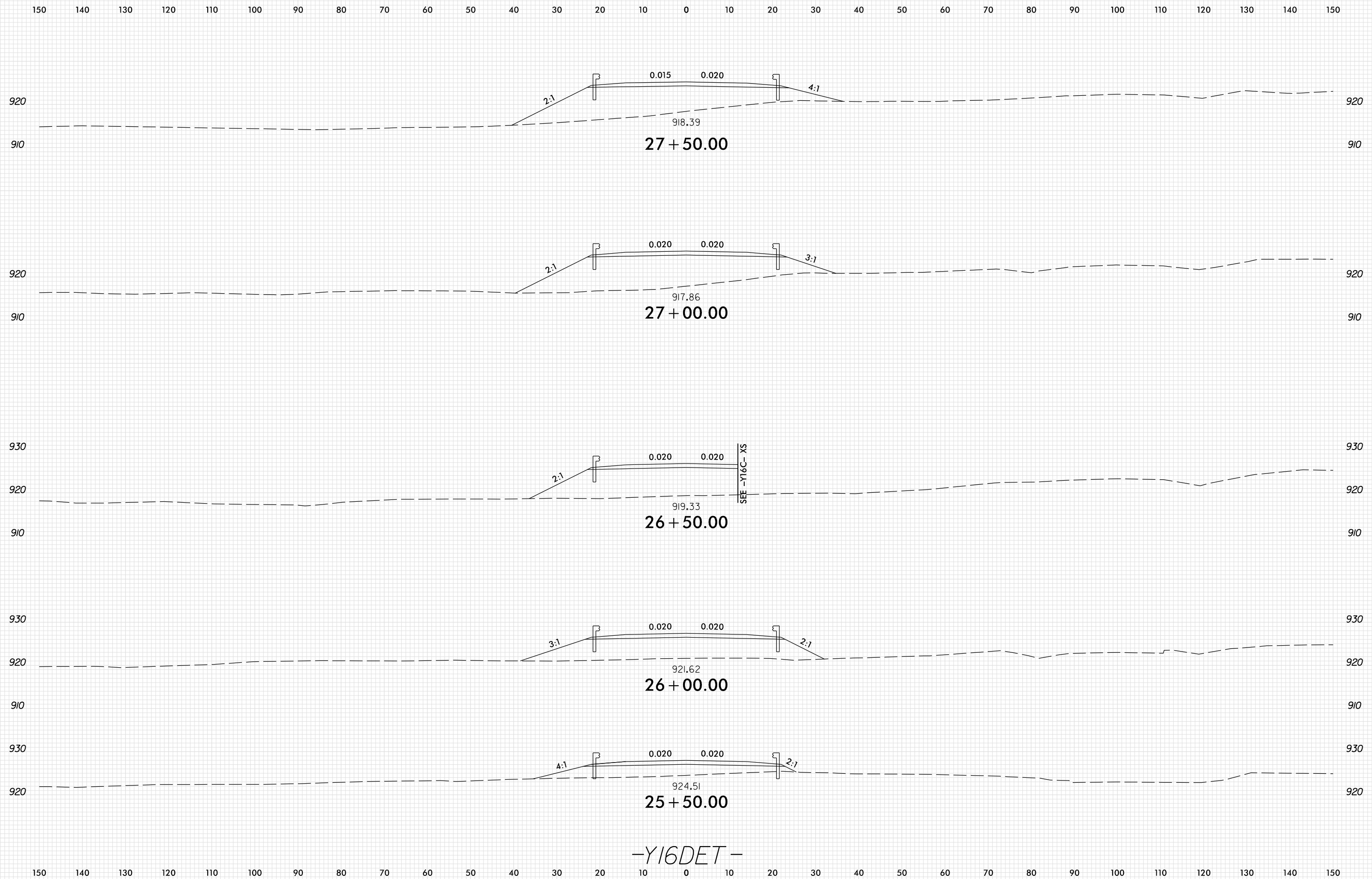

-Y16DET-

8/23/99



PROJ. REFERENCE NO.	SHEET NO.
U-2579AB	X-599

150 140 130 120 110 100 90 80 70 60 50 40 30 20 10 0 10 20 30 40 50 60 70 80 90 100 110 120 130 140 150

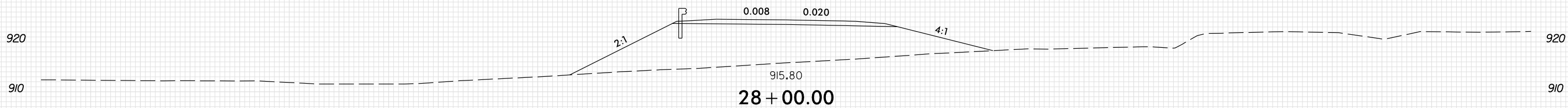
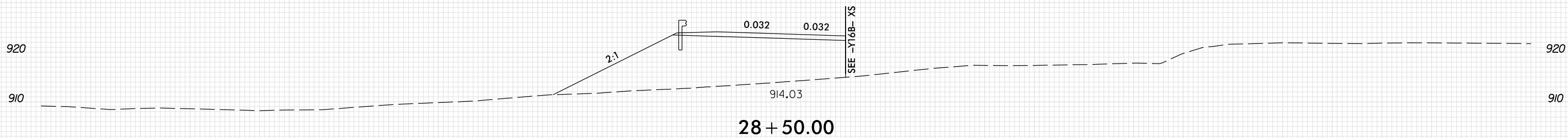
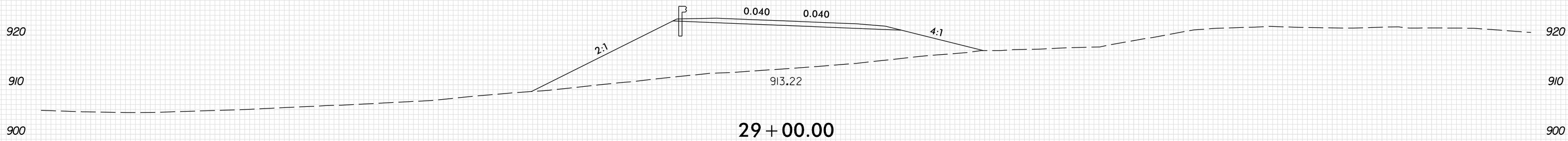
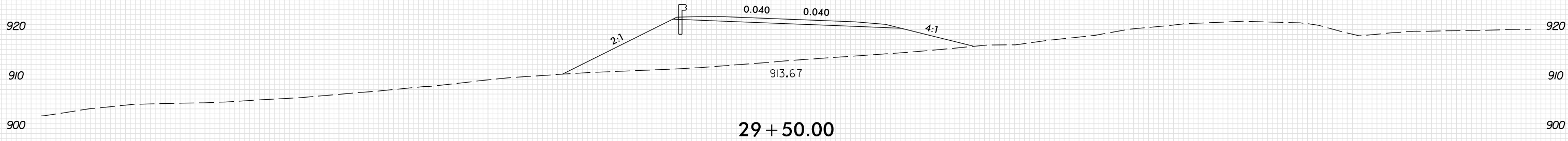

-Y16DET-

150 140 130 120 110 100 90 80 70 60 50 40 30 20 10 0 10 20 30 40 50 60 70 80 90 100 110 120 130 140 150

PLOT DRIVER: NCD01\_pdf\_color\_eng\_100.plt  
USER: SPEREIRA  
DATE: 6/10/2021  
TIME: 2:31:08 PM  
FILE: \

8/23/99



PROJ. REFERENCE NO.	SHEET NO.
U-2579AB	X-600

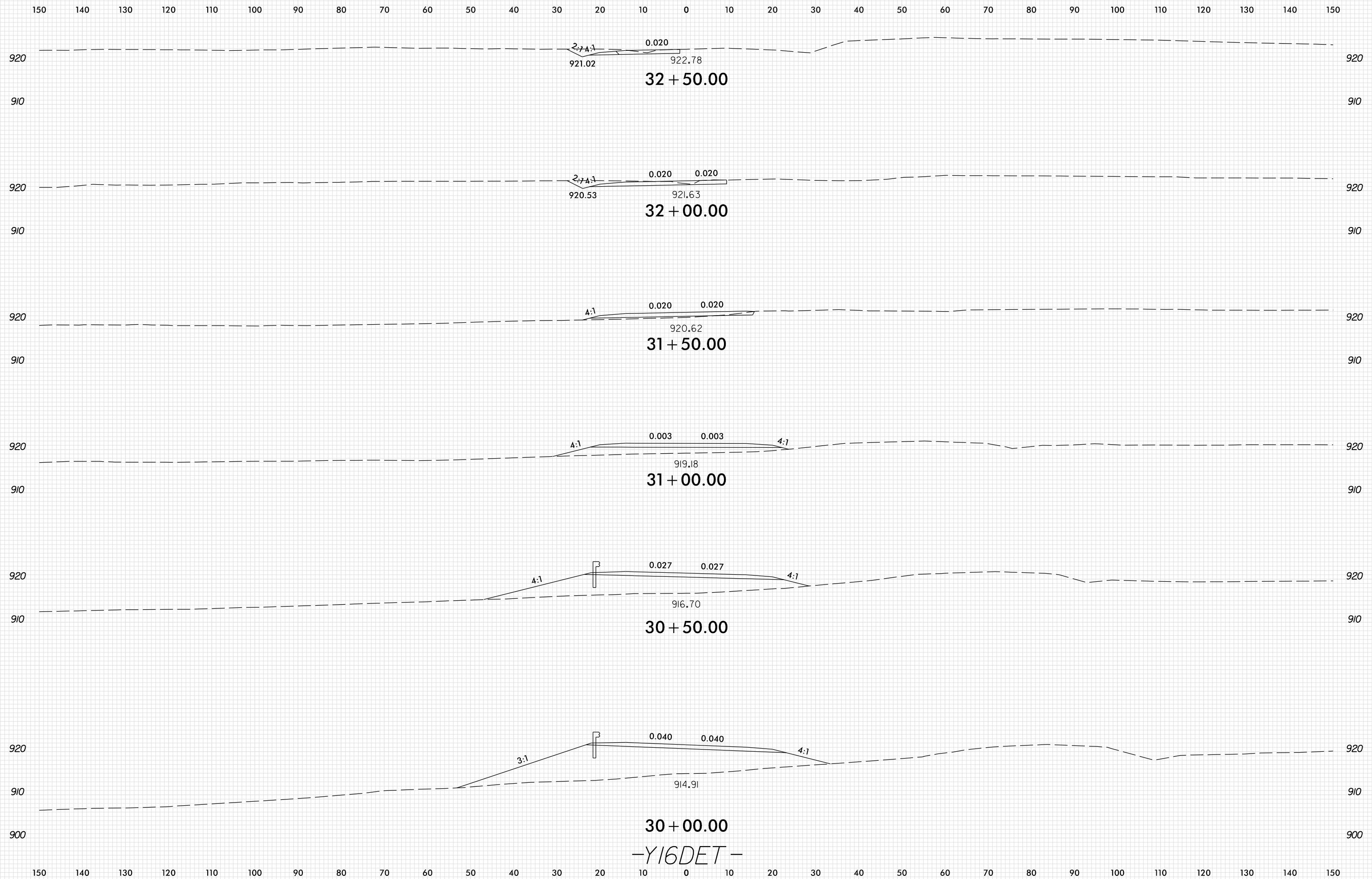

PLOT DRIVER: NCD01\_pdf\_color\_eng\_100.plt  
 USER: SPEREIRA  
 DATE: 6/10/2021  
 TIME: 2:31:09 PM  
 FILE: \

30+00.00  
 -Y16DET-

8/23/99

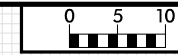

PROJ. REFERENCE NO.	SHEET NO.
U-2579AB	X-601

150 140 130 120 110 100 90 80 70 60 50 40 30 20 10 0 10 20 30 40 50 60 70 80 90 100 110 120 130 140 150

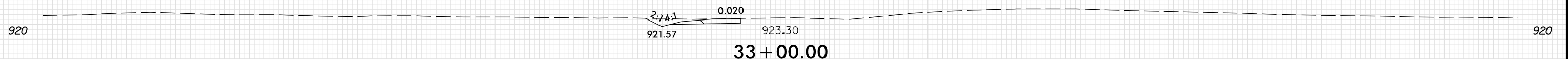
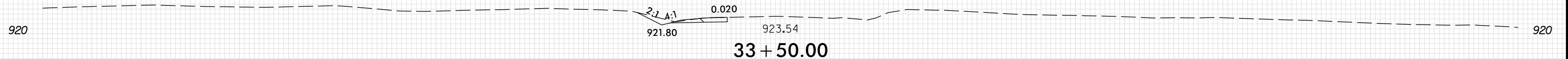
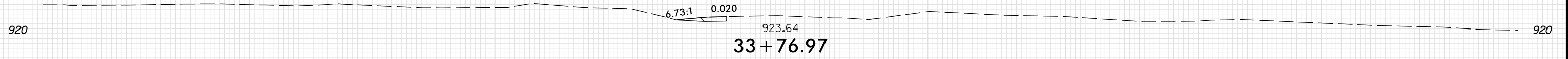

150 140 130 120 110 100 90 80 70 60 50 40 30 20 10 0 10 20 30 40 50 60 70 80 90 100 110 120 130 140 150

-Y16DET-

PLOT DRIVER: NCDOT\_pdf\_color\_eng\_100.plt  
 USER: SPEREIRA  
 DATE: 6/10/2021  
 TIME: 2:31:10 PM  
 FILE: \

8/23/99

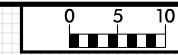

PROJ. REFERENCE NO.	SHEET NO.
U-2579AB	X-602

150 140 130 120 110 100 90 80 70 60 50 40 30 20 10 0 10 20 30 40 50 60 70 80 90 100 110 120 130 140 150

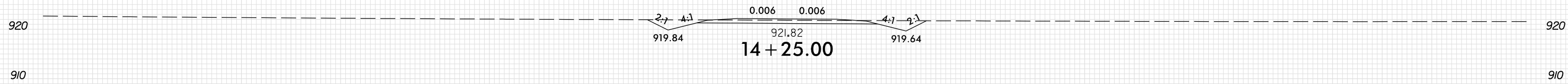
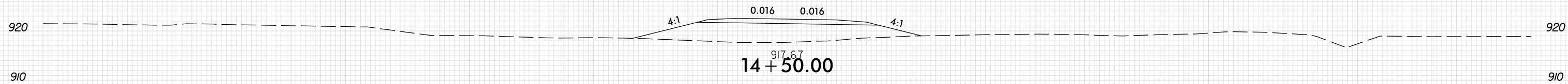
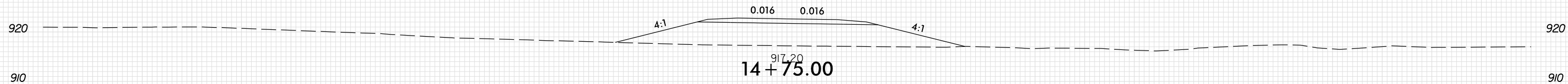
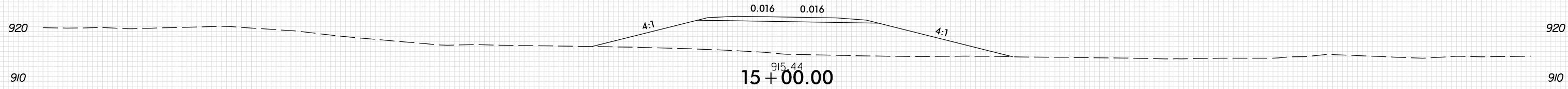

-Y16BDET-

150 140 130 120 110 100 90 80 70 60 50 40 30 20 10 0 10 20 30 40 50 60 70 80 90 100 110 120 130 140 150

PLOT DRIVER: NCD01\_pdf\_color\_eng\_100.plt  
 USER: SPEREIRA  
 DATE: 6/10/2021  
 TIME: 2:31:16 PM  
 FILE: \

8/23/99

0 5 10	PROJ. REFERENCE NO.	SHEET NO.
	U-2579AB	X-603

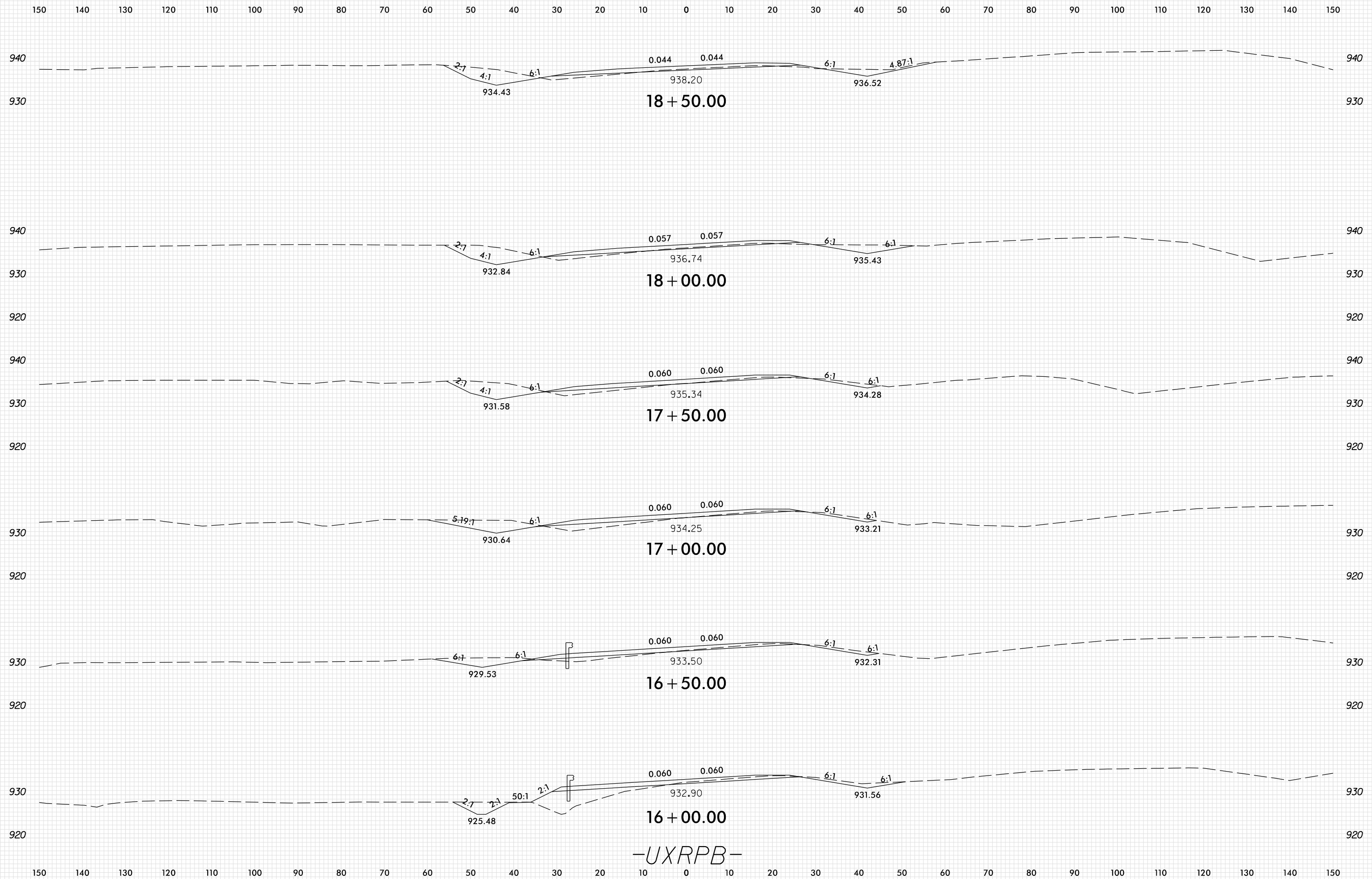

PLOT DRIVER: NCDOT\_pdf\_color\_eng\_100.plt  
 USER: SPEREIRA  
 DATE: 6/10/2021  
 TIME: 2:31:24 PM  
 FILE: \

8/23/99

0 5 10	PROJ. REFERENCE NO.	SHEET NO.
	U-2579AB	X-604

150 140 130 120 110 100 90 80 70 60 50 40 30 20 10 0 10 20 30 40 50 60 70 80 90 100 110 120 130 140 150

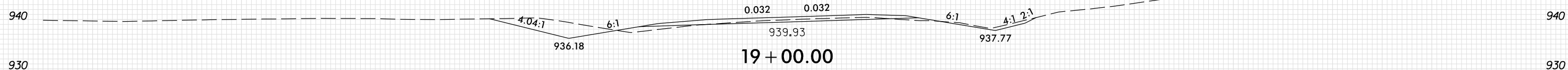
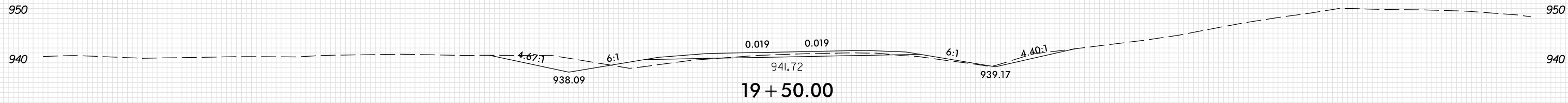
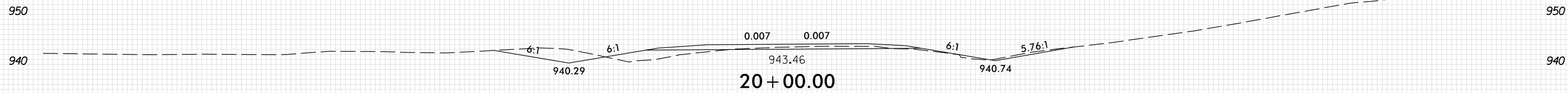
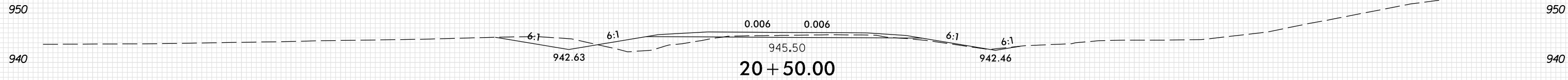

-UXRPB-

150 140 130 120 110 100 90 80 70 60 50 40 30 20 10 0 10 20 30 40 50 60 70 80 90 100 110 120 130 140 150

PLOT DRIVER: NCD01\_pdf\_color\_eng\_100.plt  
USER: SPEREIRA  
DATE: 6/10/2021  
TIME: 2:31:25 PM  
FILE: \



8/23/99



PROJ. REFERENCE NO.	SHEET NO.
U-2579AB	X-605

150 140 130 120 110 100 90 80 70 60 50 40 30 20 10 0 10 20 30 40 50 60 70 80 90 100 110 120 130 140 150

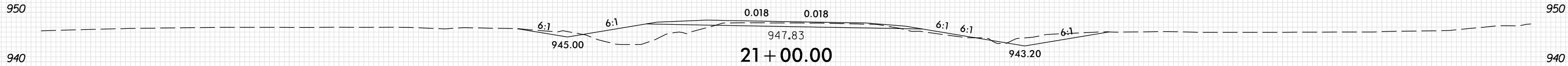
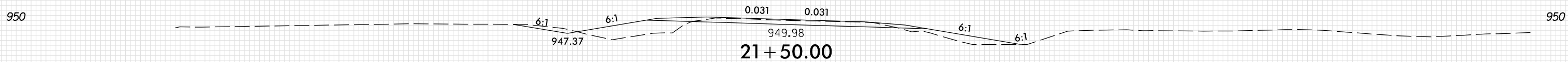
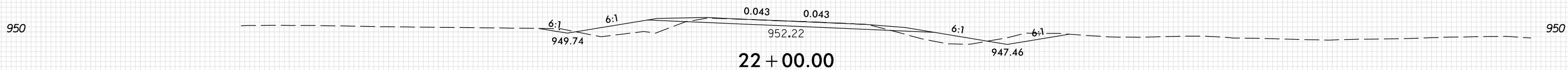
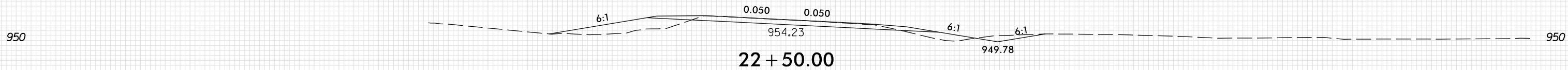
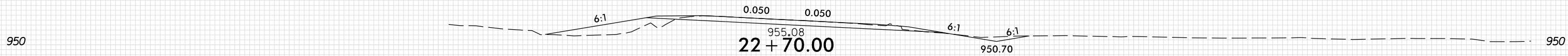

-UXRPB-

150 140 130 120 110 100 90 80 70 60 50 40 30 20 10 0 10 20 30 40 50 60 70 80 90 100 110 120 130 140 150

PLOT DRIVER: NCDOT\_pdf\_color\_eng\_100.plt  
 USER: SPEREIRA  
 DATE: 6/10/2021  
 TIME: 2:31:26 PM  
 FILE: \

8/23/99



PROJ. REFERENCE NO.	SHEET NO.
U-2579AB	X-606

150 140 130 120 110 100 90 80 70 60 50 40 30 20 10 0 10 20 30 40 50 60 70 80 90 100 110 120 130 140 150

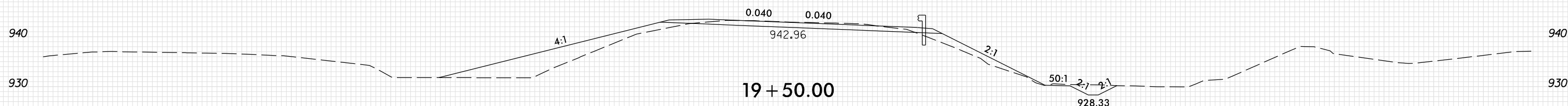
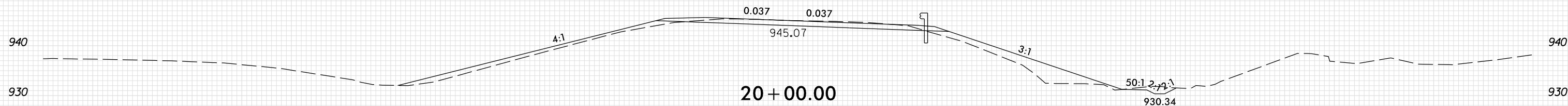
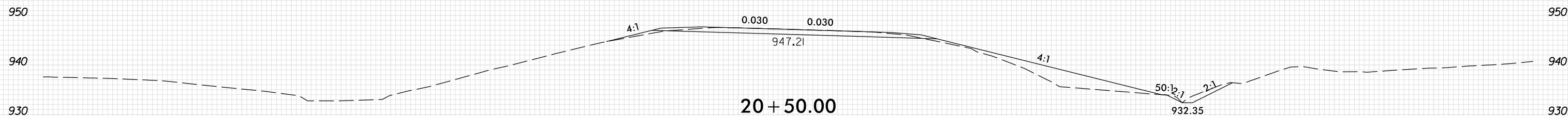
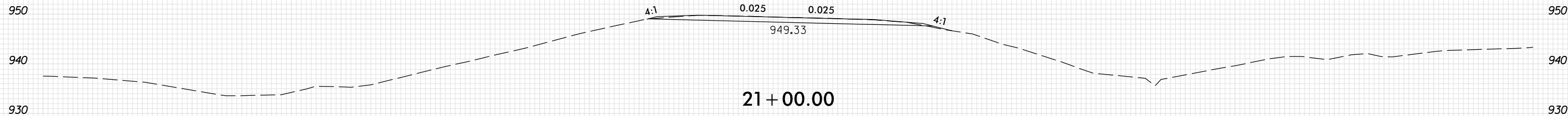

-UXRPC-

150 140 130 120 110 100 90 80 70 60 50 40 30 20 10 0 10 20 30 40 50 60 70 80 90 100 110 120 130 140 150