

CROSS SECTION INDEX OF SHEETS

-L- (LEFT SIDE)	X-1 THRU X-86A	-Y15FLYAC-	X-402 THRU X-435
-L- (RIGHT SIDE)	X-87 THRU X-172C	-Y15FLYBD-	X-436 THRU X-475
-Y1-	X-173 THRU X-174A	-Y15FLYCA-	X-476 THRU X-512
-Y1A-	X-174B THRU X-174C	-Y15LPA-	X-513 THRU X-516
-Y1B-	X-175 THRU X-186	-Y15RPA-	X-517 THRU X-530
-Y4-	X-187 THRU X-206	-Y15RPB-	X-531 THRU X-538
-Y4A-	X-207 THRU X-209	-Y15RPC-	X-539 THRU X-544
-Y4RPA-	X-210 THRU X-212	-Y15RPDREV-	X-545 THRU X-552
-Y4RPB-	X-213 THRU X-215	-Y15XOVR1-	X-553 THRU X-558
-Y4SPB1-	X-216	-Y15XOVR2-	X-559 THRU X-565
-Y4RPC-	X-217 THRU X-219	-Y16-	X-566 THRU X-571
-Y4RPD-	X-220 AND X-221	-Y16B-	X-572
-Y4SPD1-	X-222	-Y1BDET-	X-573 THRU X-581
-Y5B-	X-223 THRU X-225	-Y4DET-	X-582 THRU X-592
-Y6-	X-226	-Y16DET-	X-593 THRU X-601
-Y8-	X-227 AND X-228	-Y16BDET-	X-602
-Y15- (BEGINNING LEFT SIDE)	X-229 THRU X-249	-UXRPB-	X-603 THRU X-605
-Y15- (BEGINNING RIGHT SIDE)	X-250 THRU X-267	-UXRPC-	X-606
-Y15REV- (LEFT SIDE)	X-268 THRU X-319		
-Y15REV- (RIGHT SIDE)	X-320 THRU X-371		
-Y15- (ENDING LEFT SIDE)	X-372 THRU X-386		
-Y15- (ENDING RIGHT SIDE)	X-387 THRU X-401		

NOTES:
QUANTITIES ARE APPROXIMATE ONLY.
THE RESIDENT ENGINEER WILL RE-CROSS SECTION THE WORK ACCURATELY WHEN THE PROJECT IS STAKED OUT. THESE CROSS-SECTION NOTES WILL BE USED IN COMPUTING THE FINAL QUANTITIES FOR WHICH THE CONTRACTOR WILL BE PAID.

STATE OF NORTH CAROLINA
DIVISION OF HIGHWAYS

PROJ. REFERENCE NO. U-2579AB
SHEET NO. X-0D

Quantities are approximate only. The Resident Engineer will
re-cross-section the work accurately when the project is staked
out. These cross-section notes will be used in computing the
final quantities for which the contractor will be paid.

NOTE: EMBANKMENT COLUMN DOES NOT INCLUDE BACKFILL FOR UNDERCUT

CROSS-SECTION SUMMARY

Table with columns: Station, Uncl. Exc. (cu. yd.), Embt (cu. yd.), Station, Uncl. Exc. (cu. yd.), Embt (cu. yd.), Station, Uncl. Exc. (cu. yd.), Embt (cu. yd.), Station, Uncl. Exc. (cu. yd.), Embt (cu. yd.), Station, Uncl. Exc. (cu. yd.), Embt (cu. yd.), Station, Uncl. Exc. (cu. yd.), Embt (cu. yd.). Rows include stationing from 45+00.00 to 21+00.00.

8/23/99



PROJ. REFERENCE NO. U-2579AB SHEET NO. X-1

INCOMPLETE PLANS
DO NOT USE FOR R/W ACQUISITION

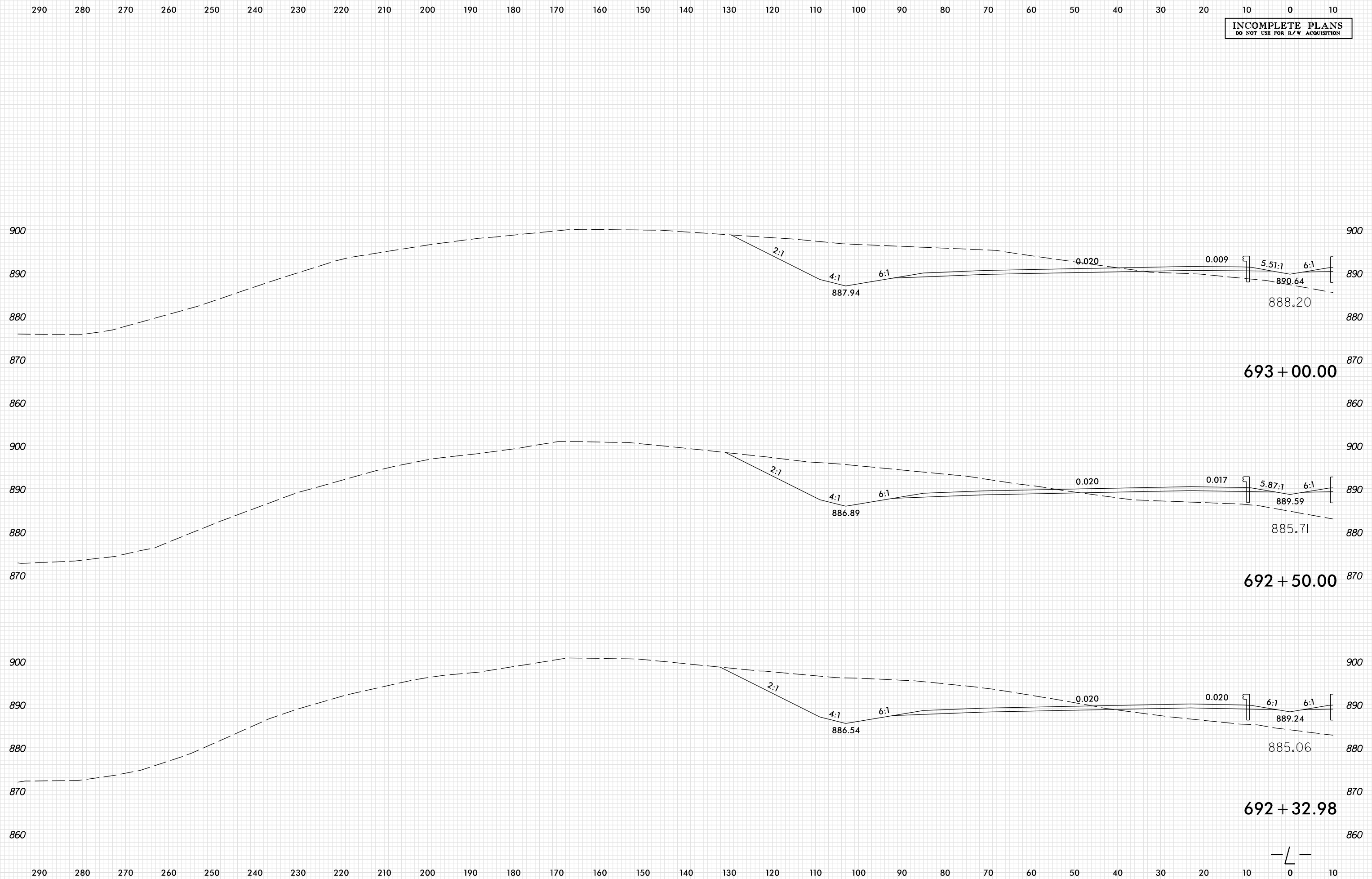

PLOT DRIVER: NCDOT_pdf_color_eng_100.plt
USER: SPEREIRA
DATE: 6/10/2021
TIME: 2:15:46 PM
FILE: \

8/23/99

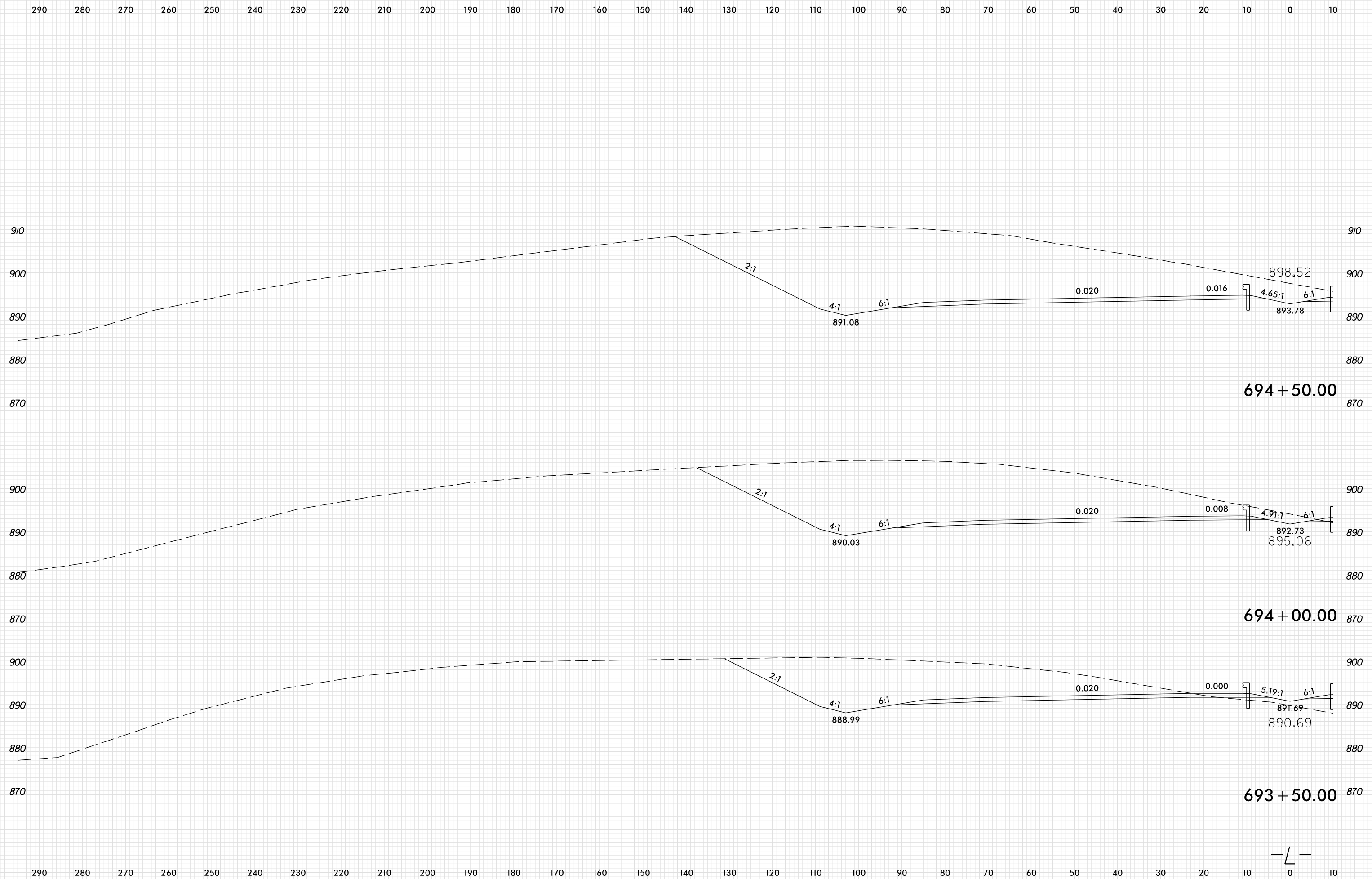

PLOT DRIVER: NCDOT_pdf_color_eng_100.plt
 USER: SPEREIRA
 DATE: 6/10/2021
 TIME: 2:15:47 PM
 FILE: \

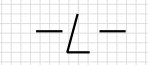

8/23/99

0 5 10	PROJ. REFERENCE NO.	SHEET NO.
	U-2579AB	X-3

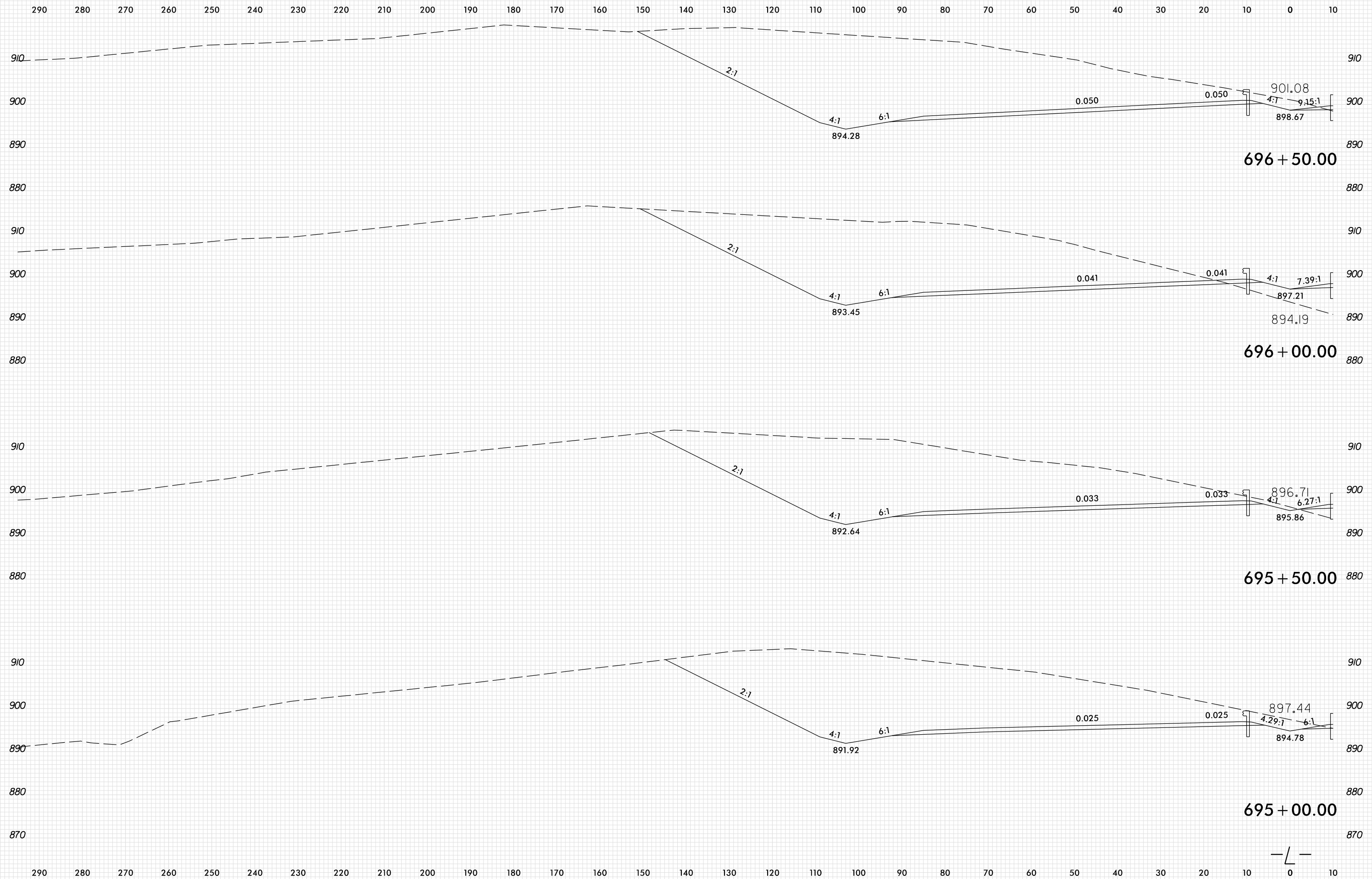

PLOT DRIVER: NCDOT_pdf_color_eng_100.plt
 USER: SPEREIRA
 DATE: 6/10/2021
 TIME: 2:15:47 PM
 FILE: \

8/23/99

0 5 10	PROJ. REFERENCE NO.	SHEET NO.
	U-2579AB	X-4

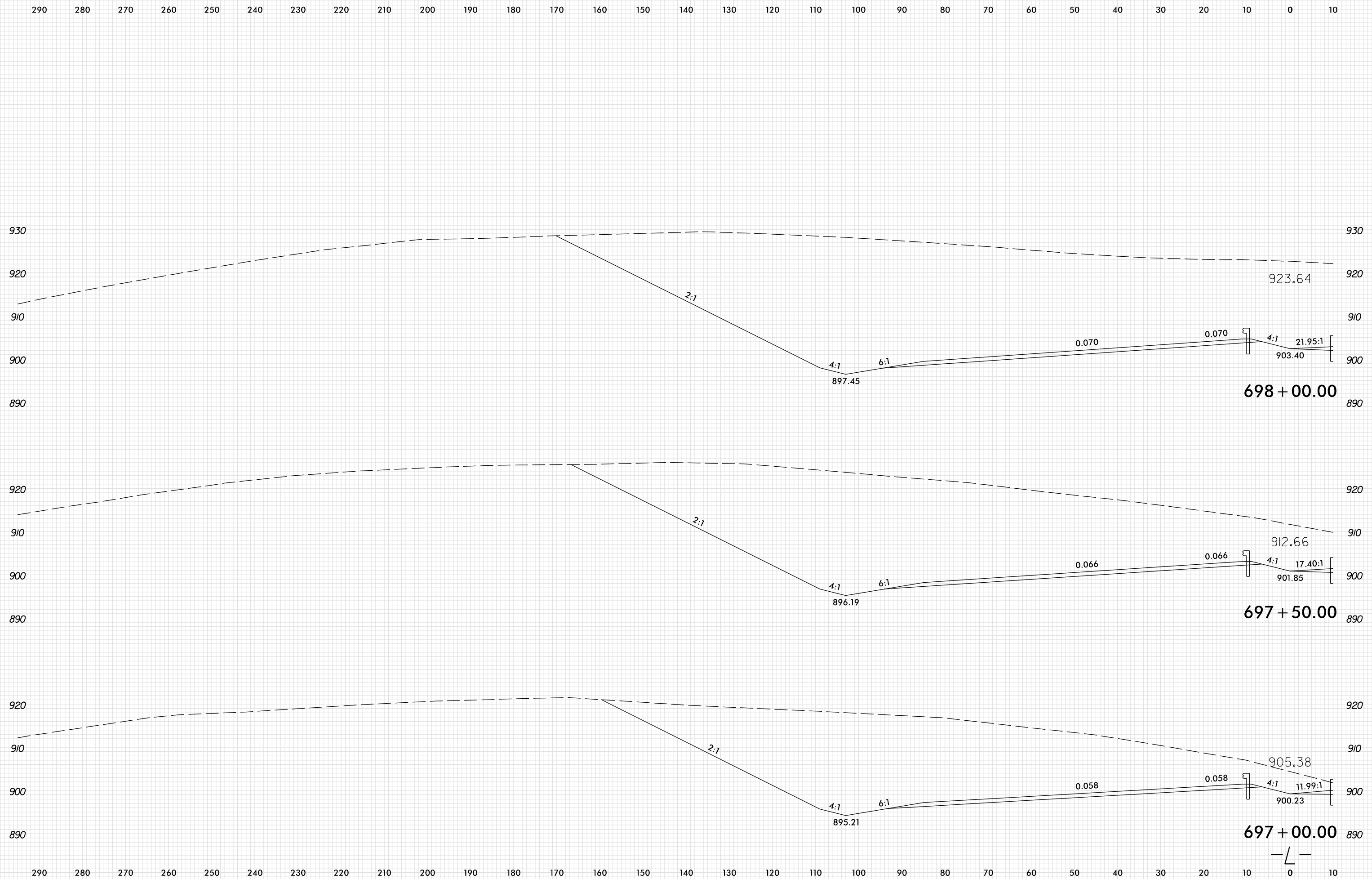

PLOT DRIVER: NCDOT_pdf_color_eng_100.plt
 USER: SPEREIRA
 DATE: 6/10/2021
 TIME: 2:15:48 PM

8/23/99

0 5 10	PROJ. REFERENCE NO.	SHEET NO.
	U-2579AB	X-5

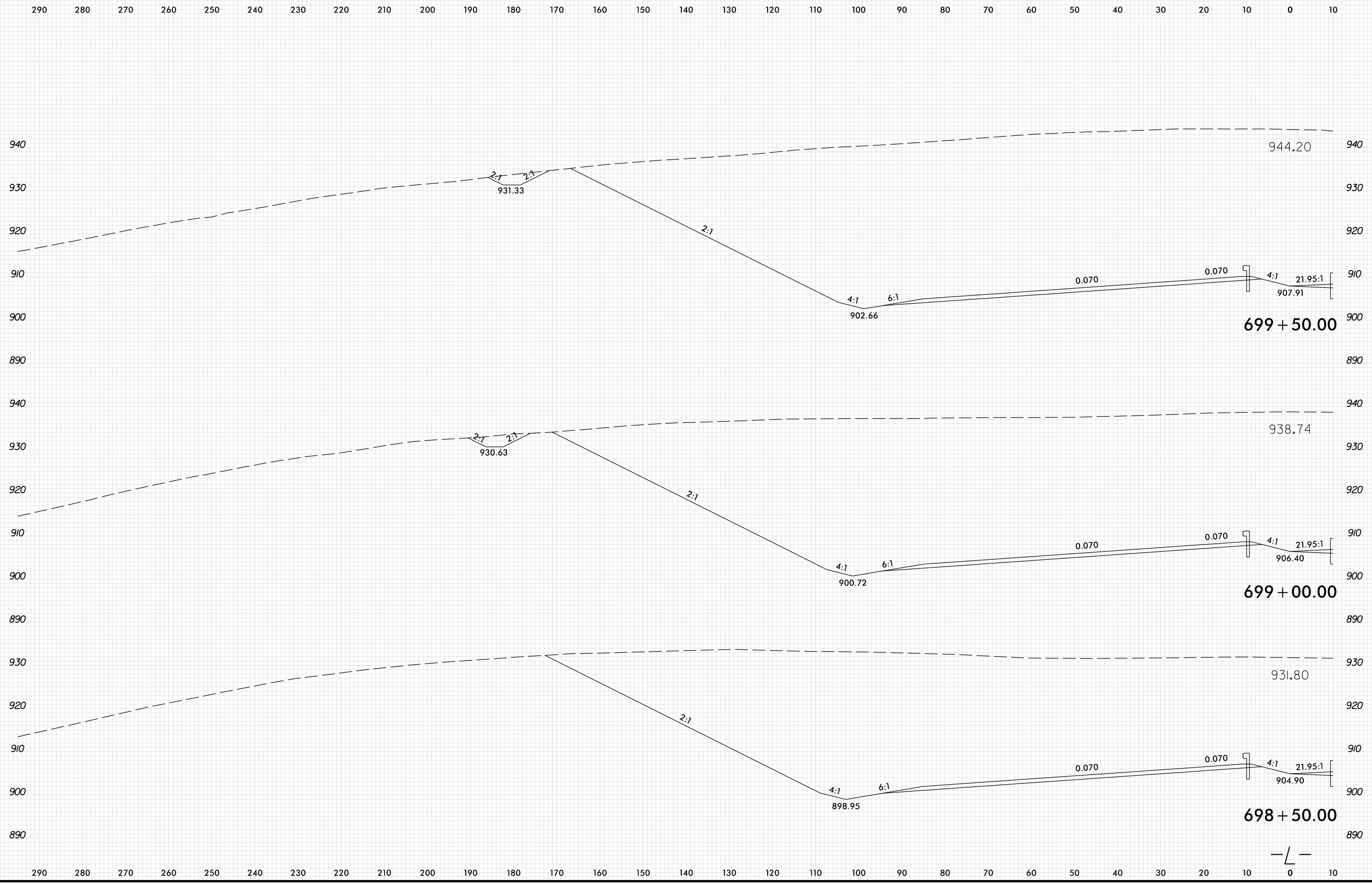

PLOT DRIVER: NCDOT_pdf_color_eng_100.plt
 USER: SPEREIRA
 DATE: 6/10/2021
 TIME: 2:15:49 PM
 FILE: \

8/23/99

0 5 10	PROJ. REFERENCE NO.	SHEET NO.
	U-2579AB	X-6

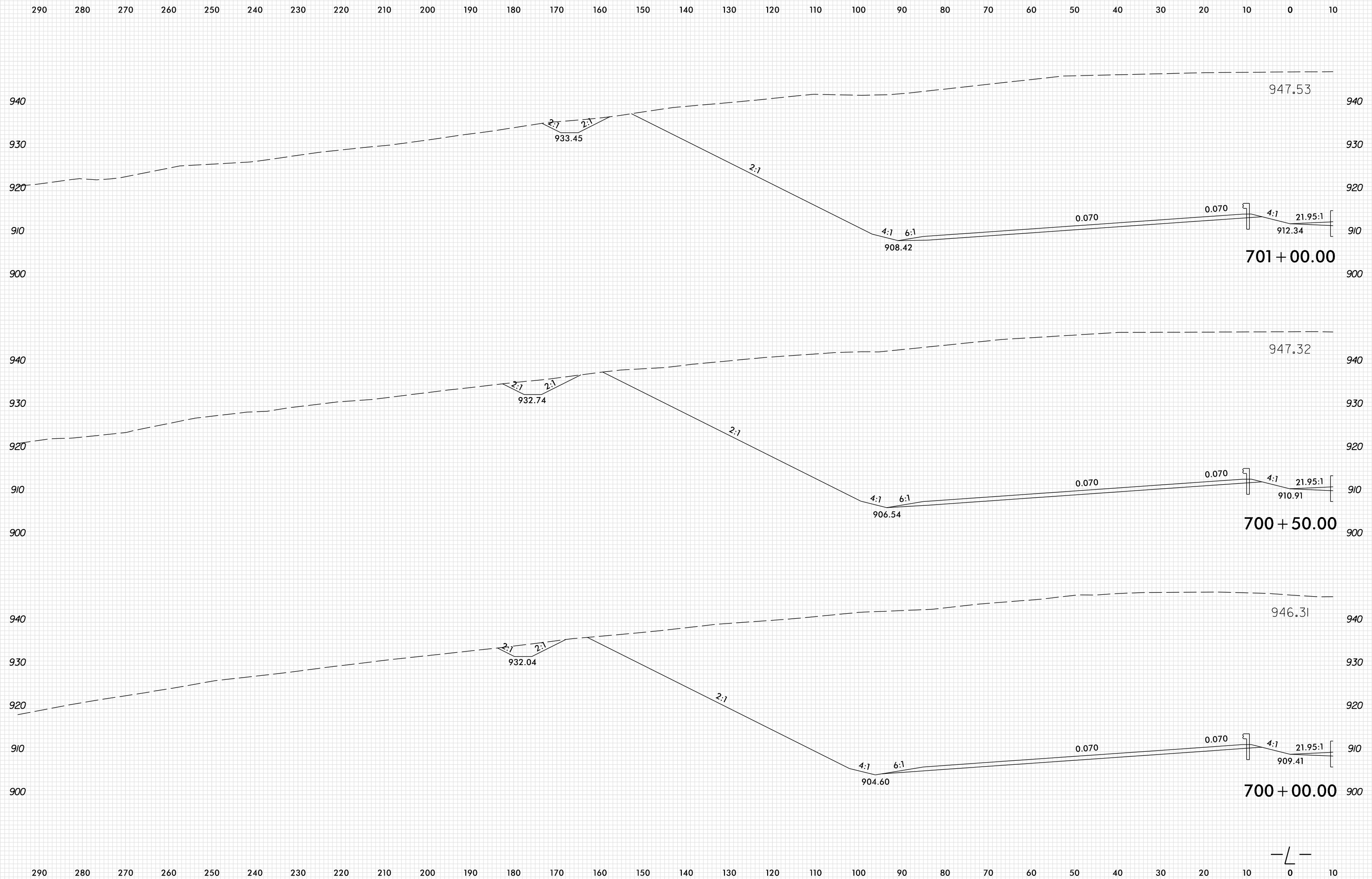

PLOT DRIVER: NCDOT_pdf_color_eng_100.plt
 USER: SPEREIRA
 DATE: 6/10/2021
 TIME: 2:15:49 PM
 FILE: \

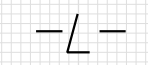

8/23/99

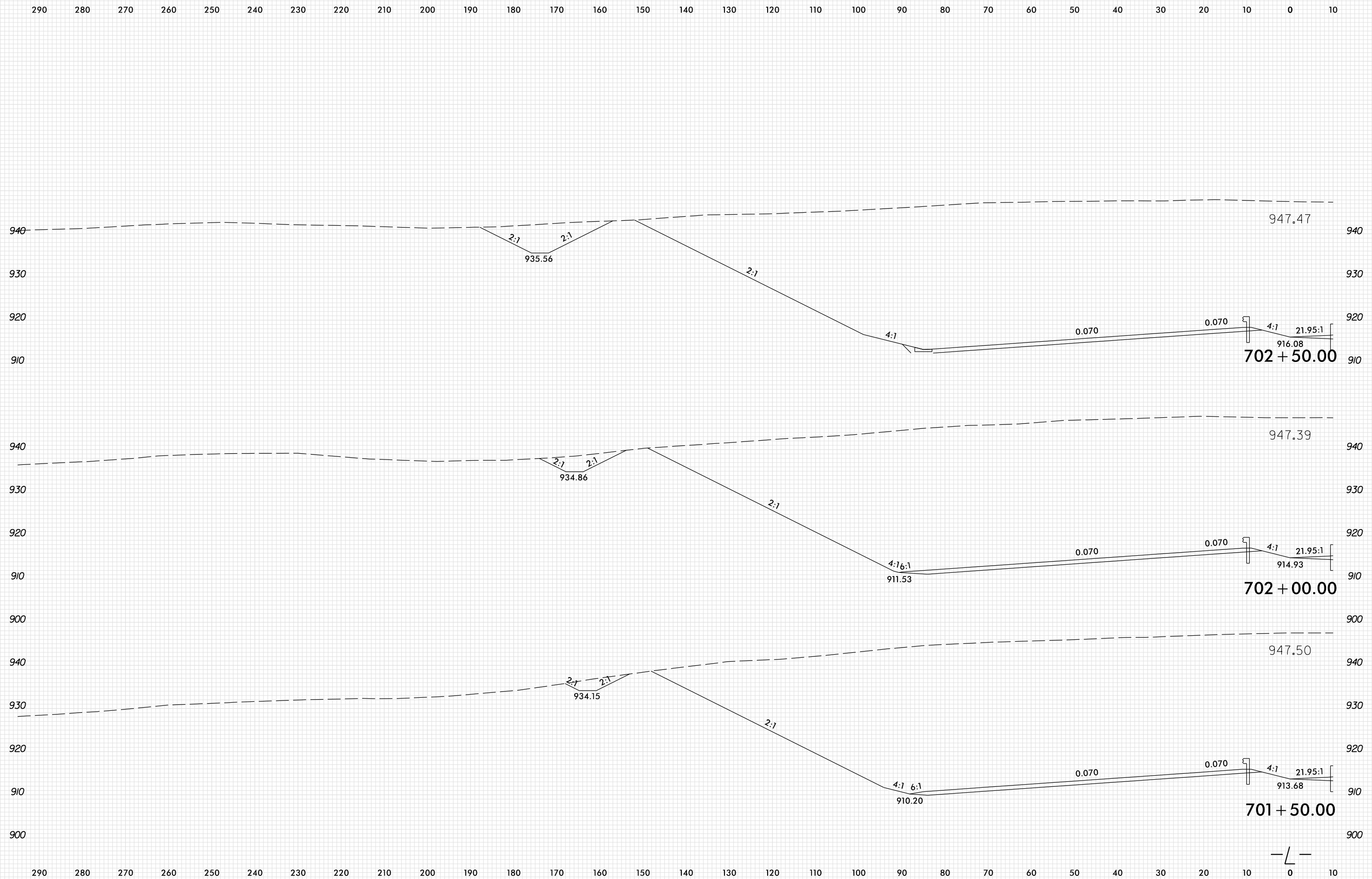

PLOT DRIVER: NCD01_pdf_color_eng_100.plt
 USER: SPEREIRA
 DATE: 6/10/2021
 TIME: 2:15:50 PM
 FILE: \

8/23/99

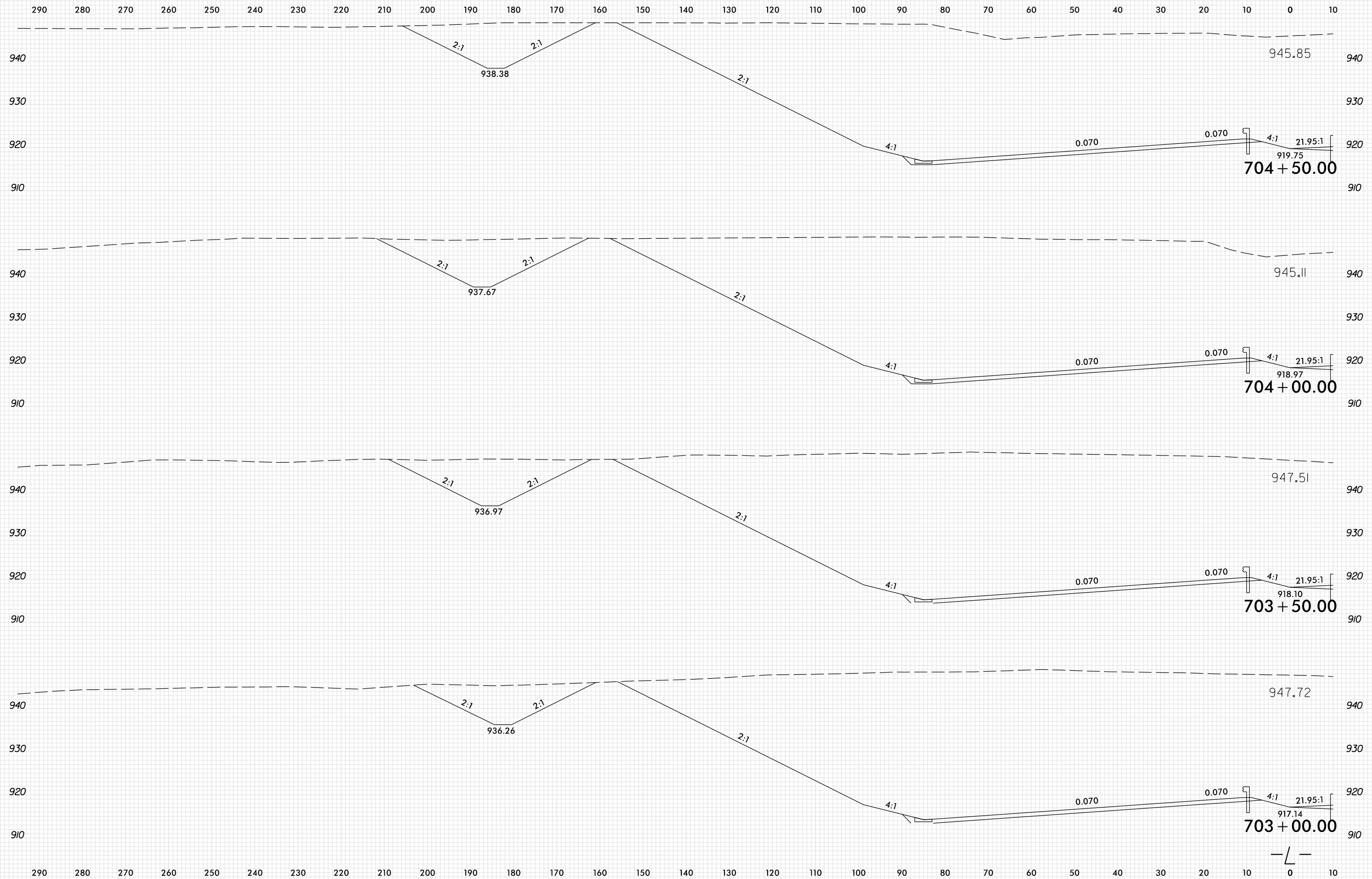

PLOT DRIVER: NCDOT_pdf_color_eng_100.plt
 USER: SPEREIRA
 DATE: 6/10/2021
 TIME: 2:15:51 PM
 FILE: \

8/23/99

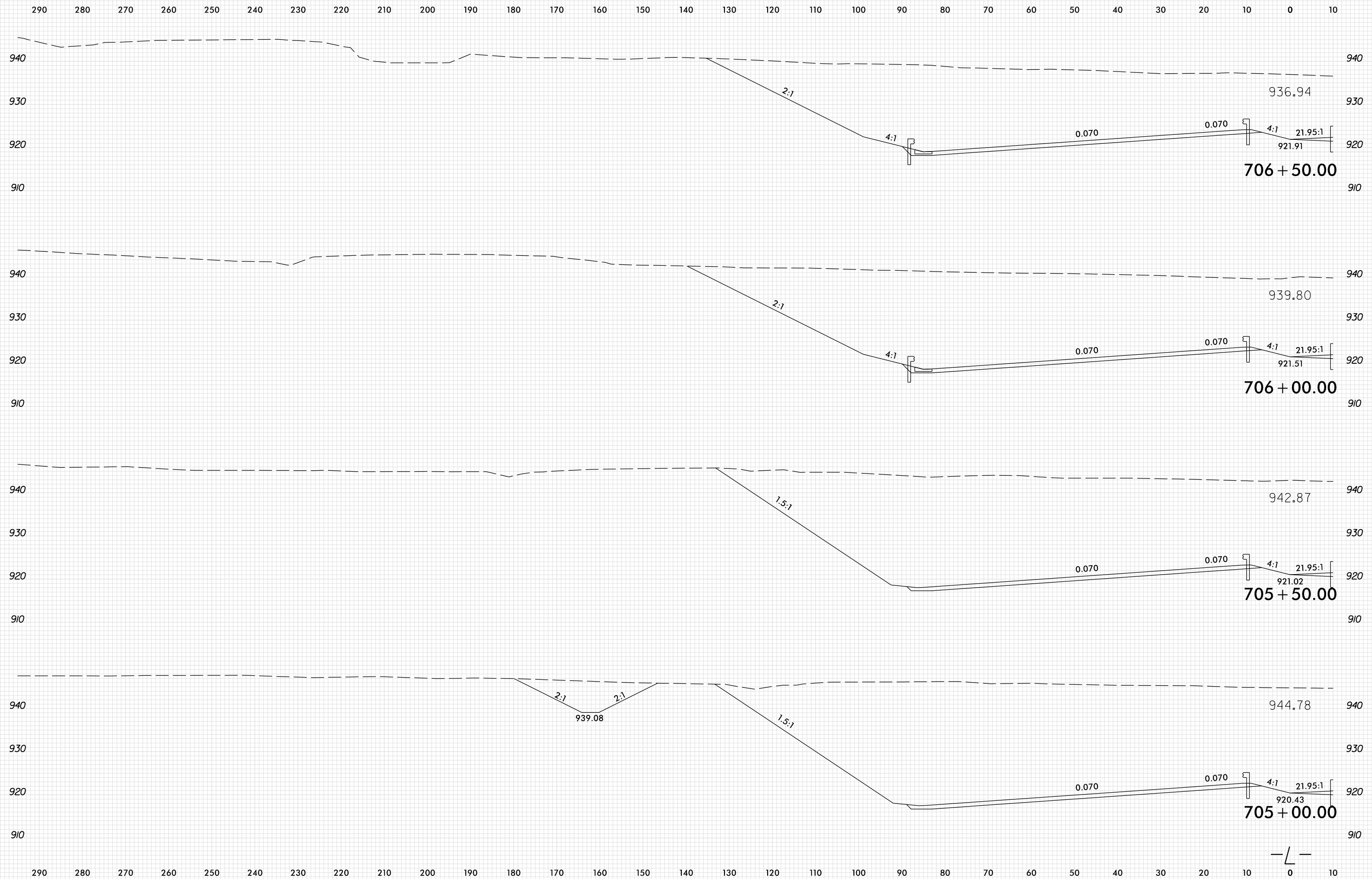

PLOT DRIVER: NCDOT_pdf_color_eng_100.plt
 USER: SPEREIRA
 DATE: 6/10/2021
 TIME: 2:15:51 PM
 FILE: \

8/23/99

290 280 270 260 250 240 230 220 210 200 190 180 170 160 150 140 130 120 110 100 90 80 70 60 50 40 30 20 10 0 10

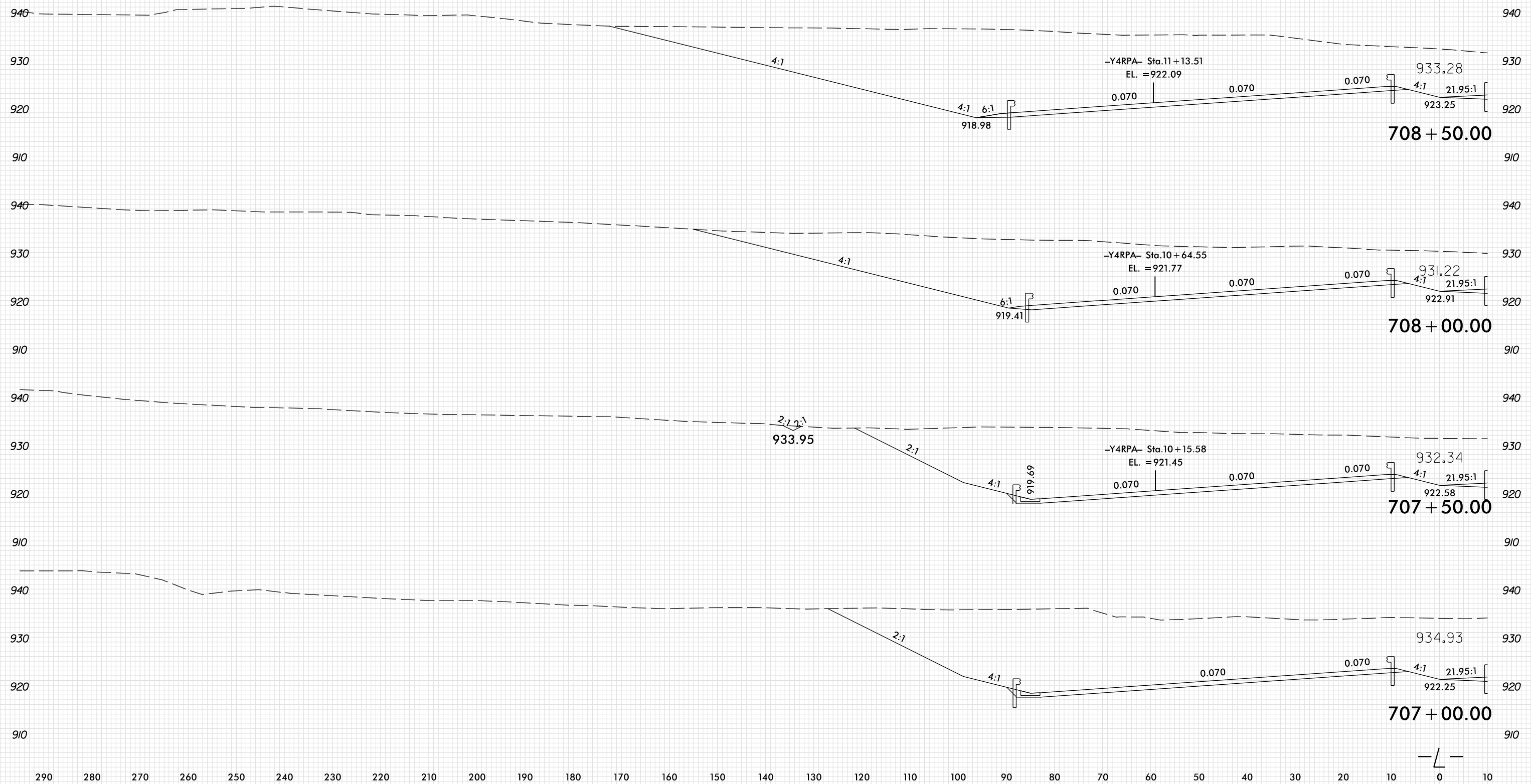

PLOT DRIVER: NCD01...pdf_color_eng_100.pdf
USER: SPEREIRA
DATE: 6/10/2021
TIME: 2:15:52 PM
FILE: \

290 280 270 260 250 240 230 220 210 200 190 180 170 160 150 140 130 120 110 100 90 80 70 60 50 40 30 20 10 0 10

8/23/99

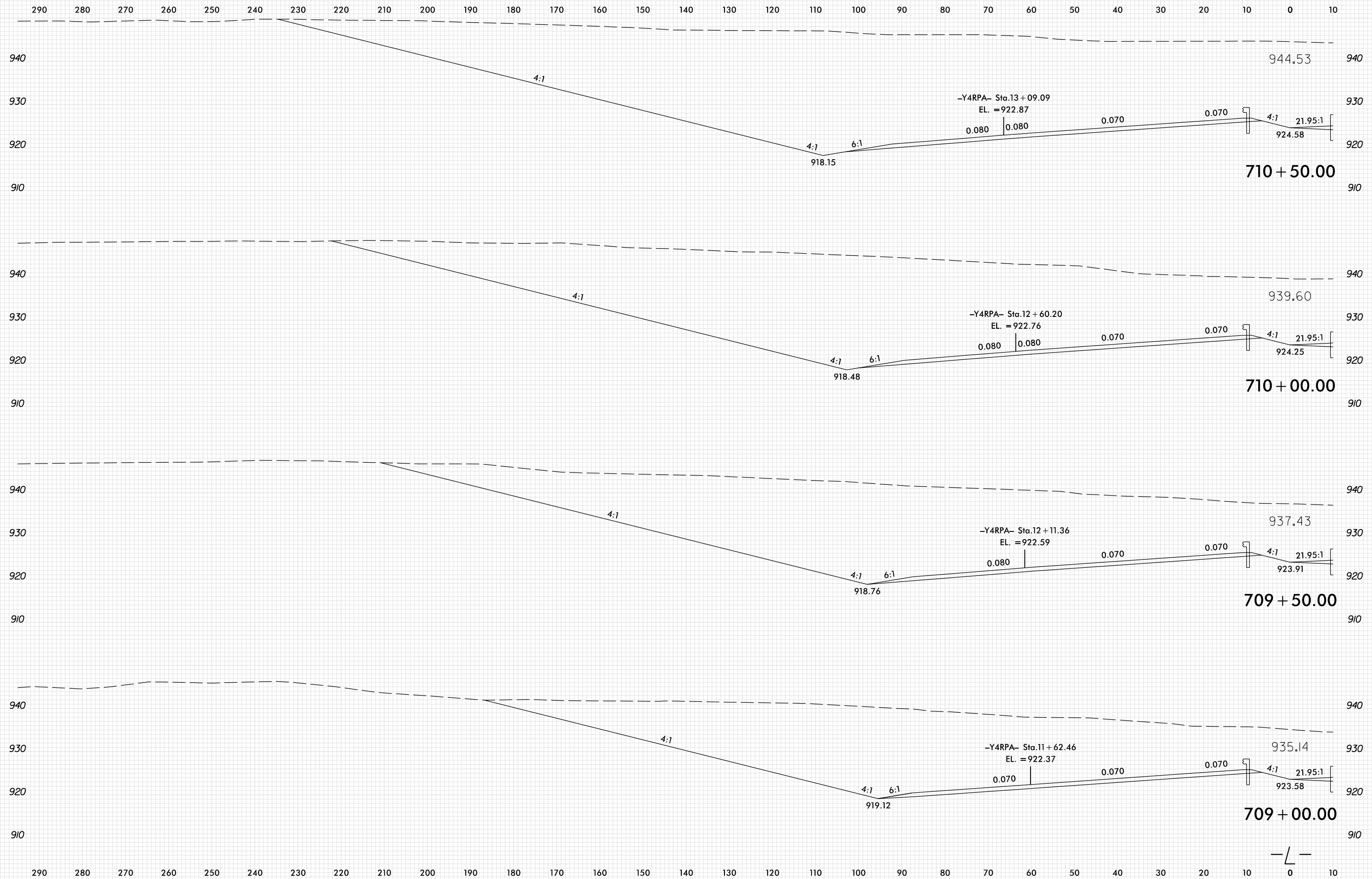

PLOT DRIVER: NCDOT_pdf_color_eng_100.plt
 USER: SPEREIRA
 DATE: 6/10/2021
 TIME: 2:15:52 PM
 FILE: \

8/23/99

0 5 10	PROJ. REFERENCE NO.	SHEET NO.
	U-2579AB	X-12

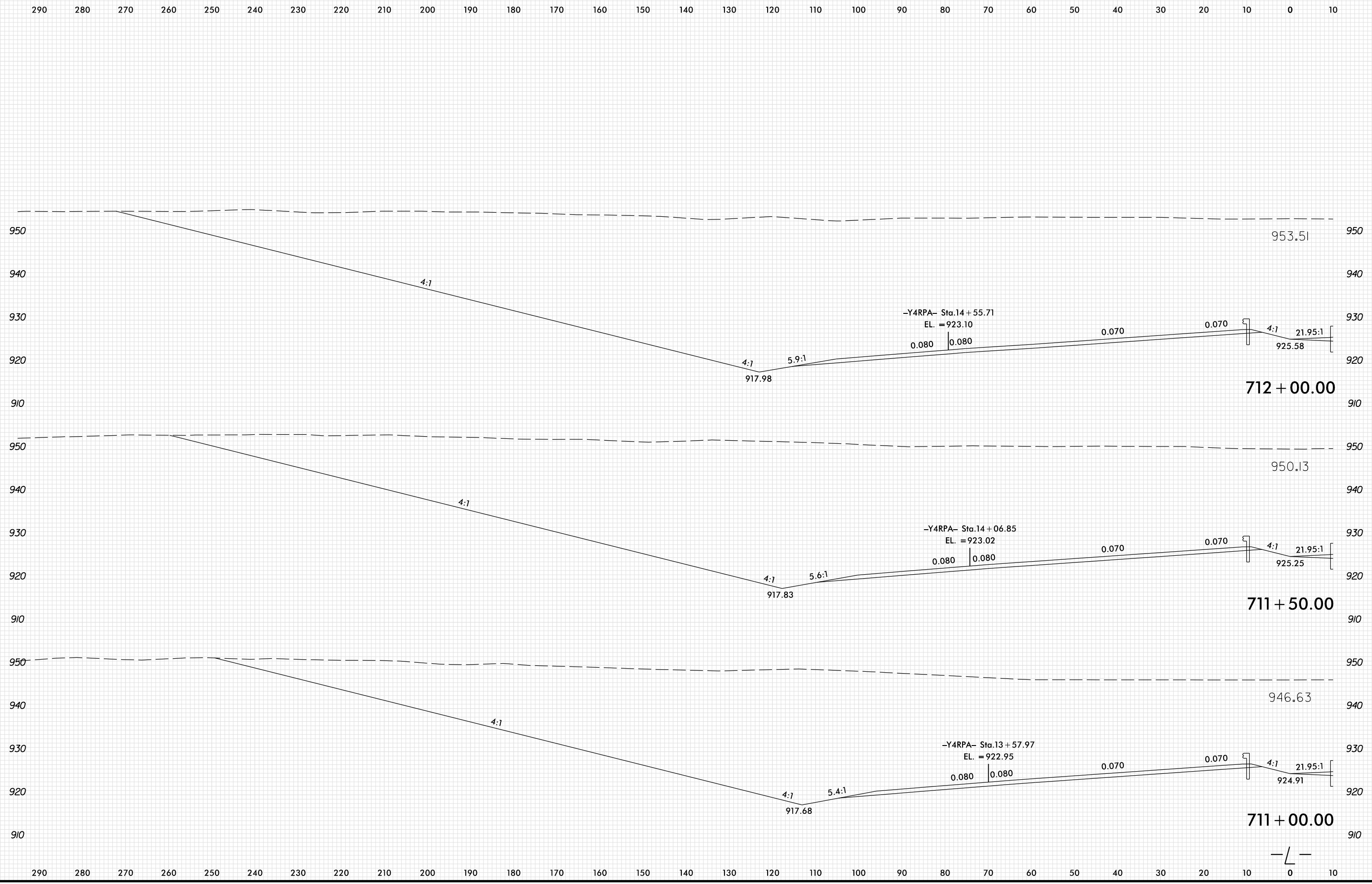

PLOT DRIVER: NCD01_pdf_color_eng_100.plt
 USER: SPEREIRA
 DATE: 6/10/2021
 TIME: 2:15:53 PM
 FILE: \

8/23/99

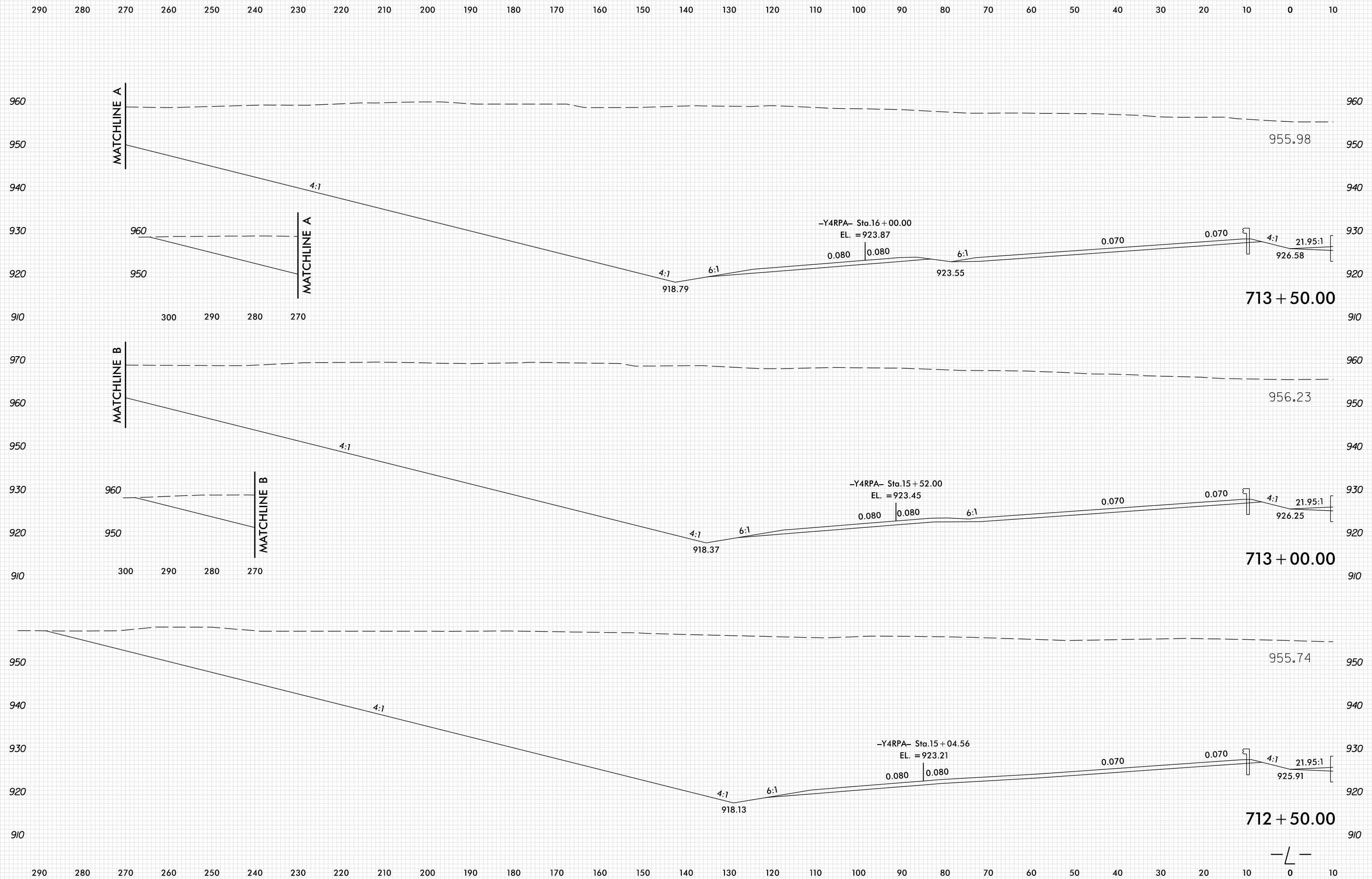

PLOT DRIVER: NCDOT_pdf_color_eng_100.plt
 USER: SPEREIRA
 DATE: 6/10/2021
 TIME: 2:15:54 PM
 FILE: \

8/23/99

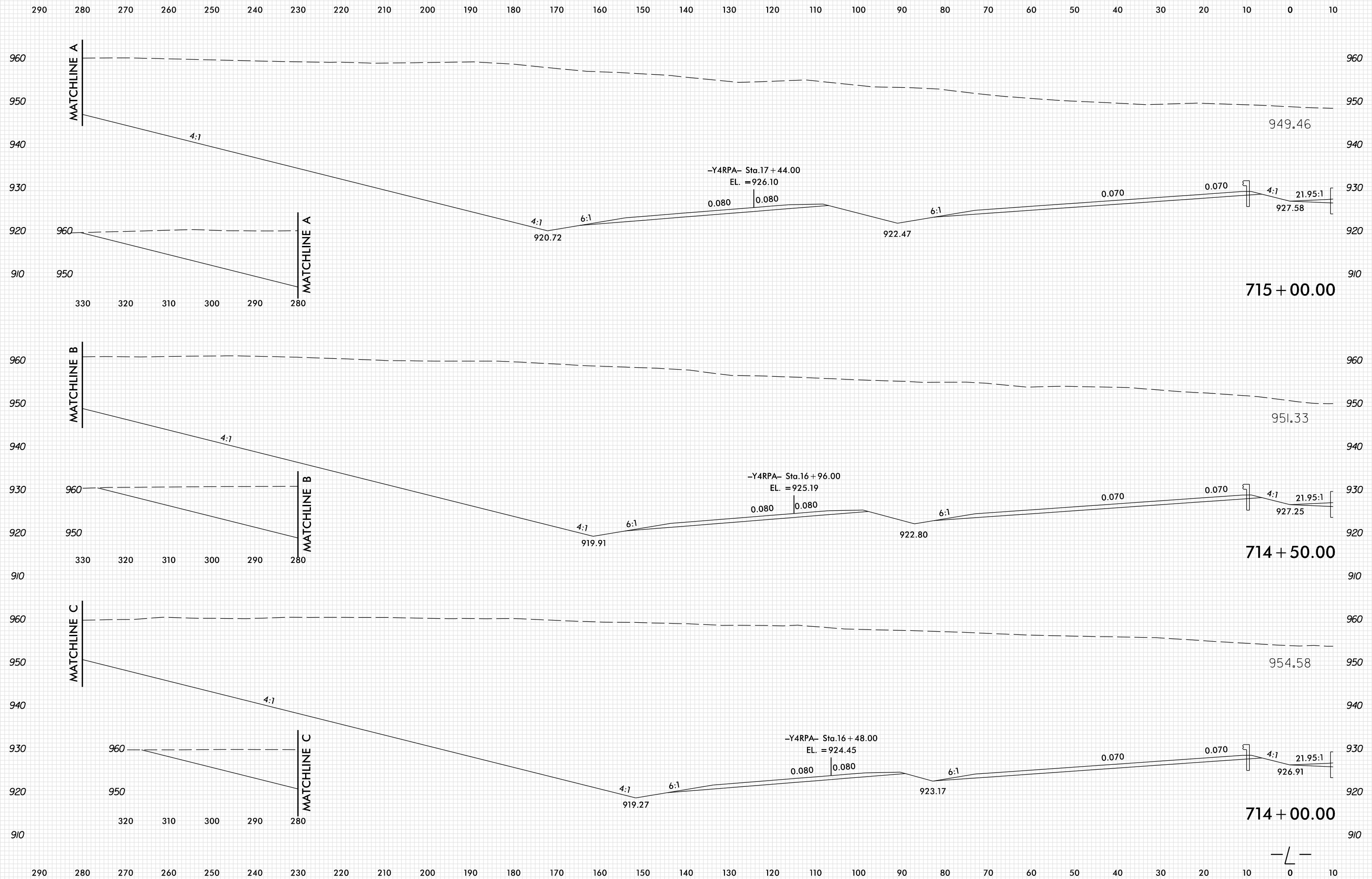

PLOT DRIVER: NCDOT_pdf_color_eng_100.plt
 USER: SPEREIRA
 DATE: 6/10/2021
 TIME: 2:15:54 PM
 FILE: \

8/23/99

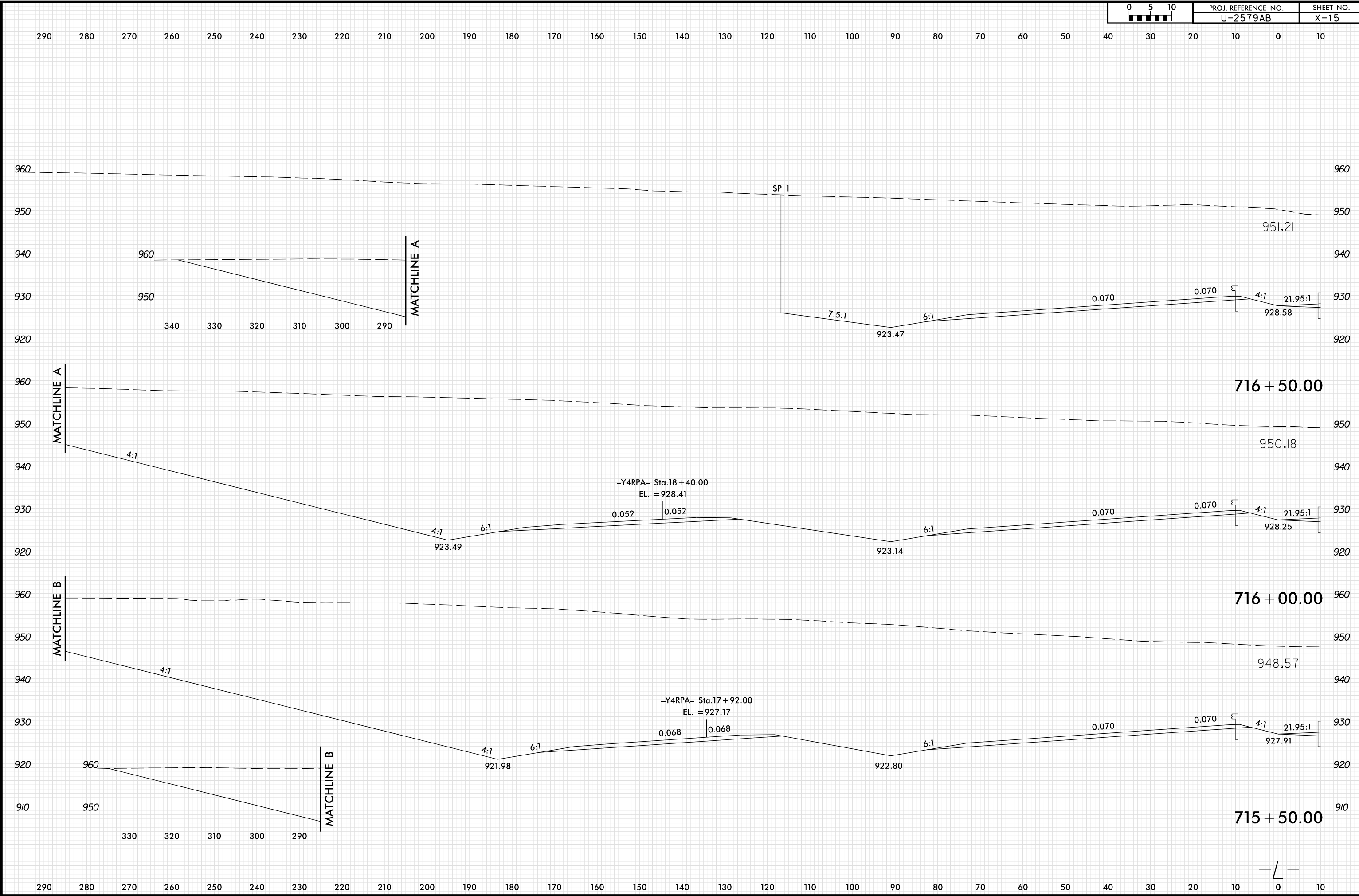

PLOT DRIVER: NCDOT_pdf_color_eng_100.plt
 USER: SPEREIRA
 DATE: 6/10/2021
 TIME: 2:15:55 PM
 FILE: \

8/23/99



PROJ. REFERENCE NO.	SHEET NO.
U-2579AB	X-16

290 280 270 260 250 240 230 220 210 200 190 180 170 160 150 140 130 120 110 100 90 80 70 60 50 40 30 20 10 0 10

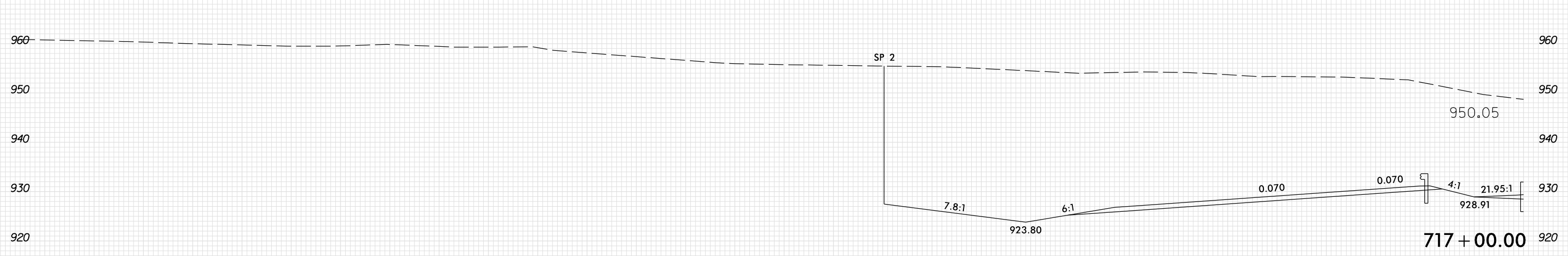
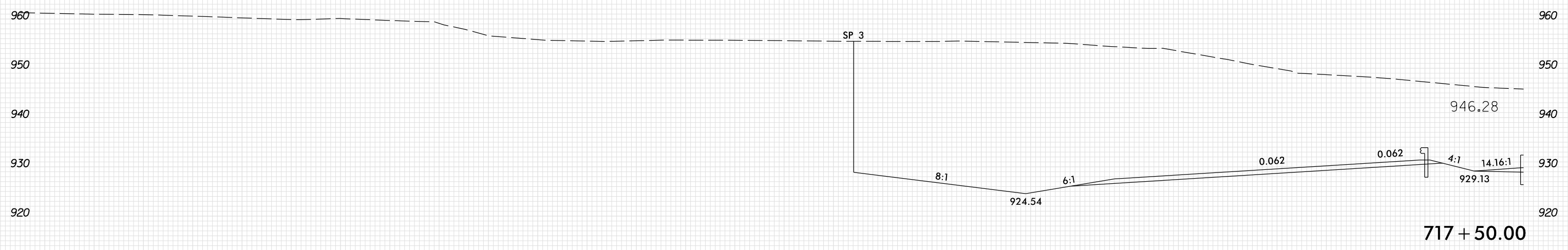
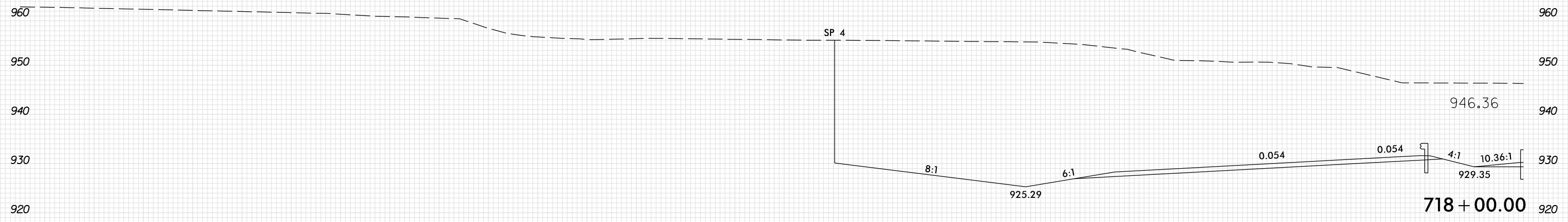

290 280 270 260 250 240 230 220 210 200 190 180 170 160 150 140 130 120 110 100 90 80 70 60 50 40 30 20 10 0 10

PLOT DRIVER: NCDOT_pdf_color_eng_100.plt
 USER: SPEREIRA
 DATE: 6/10/2021
 TIME: 2:15:55 PM
 FILE: \

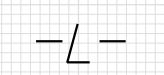

8/23/99

290 280 270 260 250 240 230 220 210 200 190 180 170 160 150 140 130 120 110 100 90 80 70 60 50 40 30 20 10 0 10

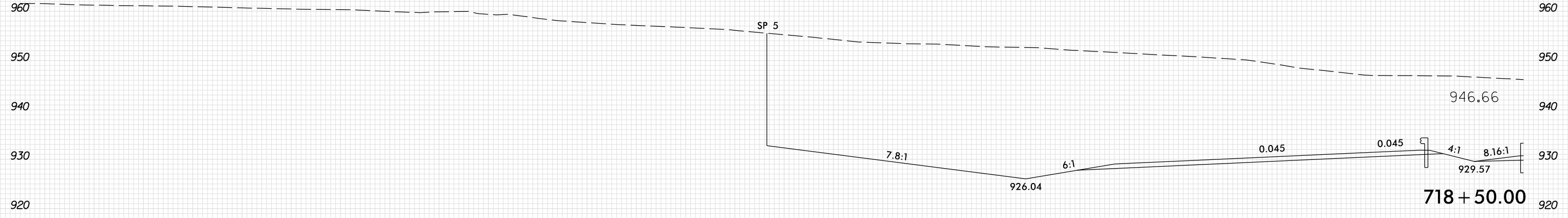
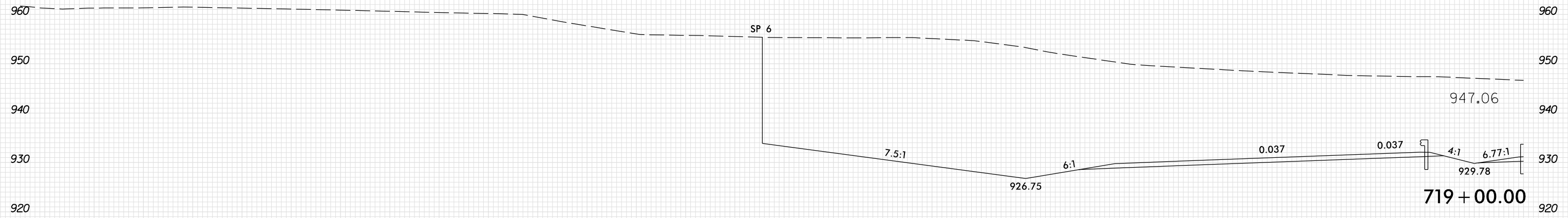
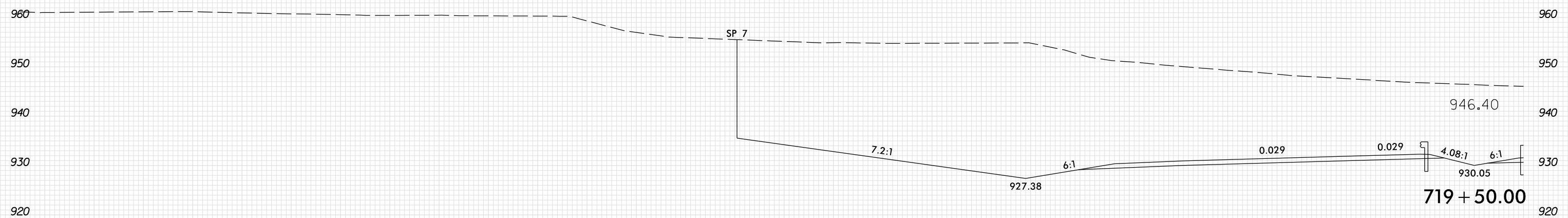

290 280 270 260 250 240 230 220 210 200 190 180 170 160 150 140 130 120 110 100 90 80 70 60 50 40 30 20 10 0 10

PLOT DRIVER: NCD01_pdf_color_eng_100.plt
 USER: SPEREIRA
 DATE: 6/10/2021
 TIME: 2:15:56 PM
 FILE: \

8/23/99

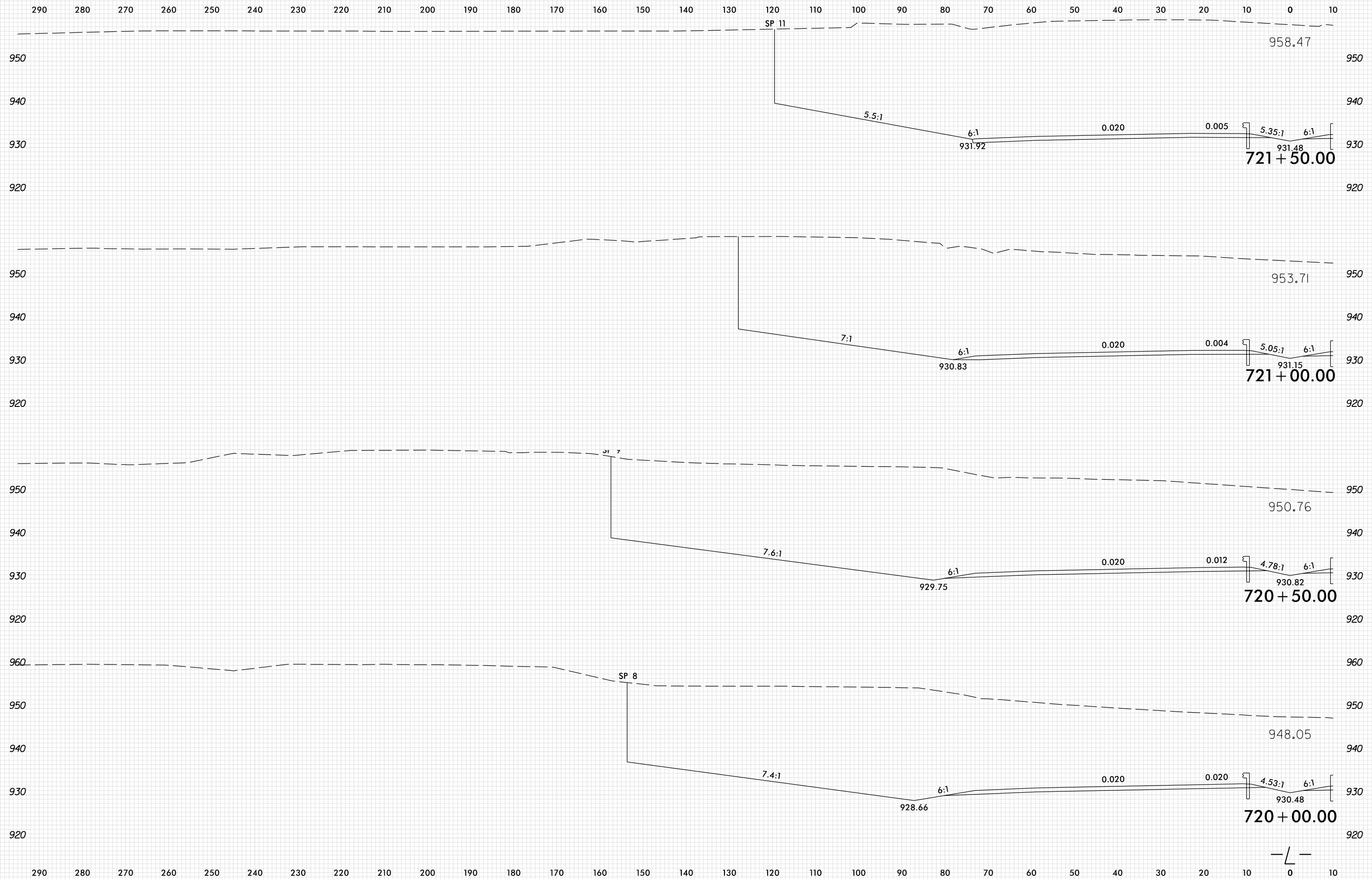

PLOT DRIVER: NCDOT_pdf_color_eng_100.plt
 USER: SPEREIRA
 DATE: 6/10/2021
 TIME: 2:15:57 PM
 FILE: \

8/23/99

290 280 270 260 250 240 230 220 210 200 190 180 170 160 150 140 130 120 110 100 90 80 70 60 50 40 30 20 10 0 10

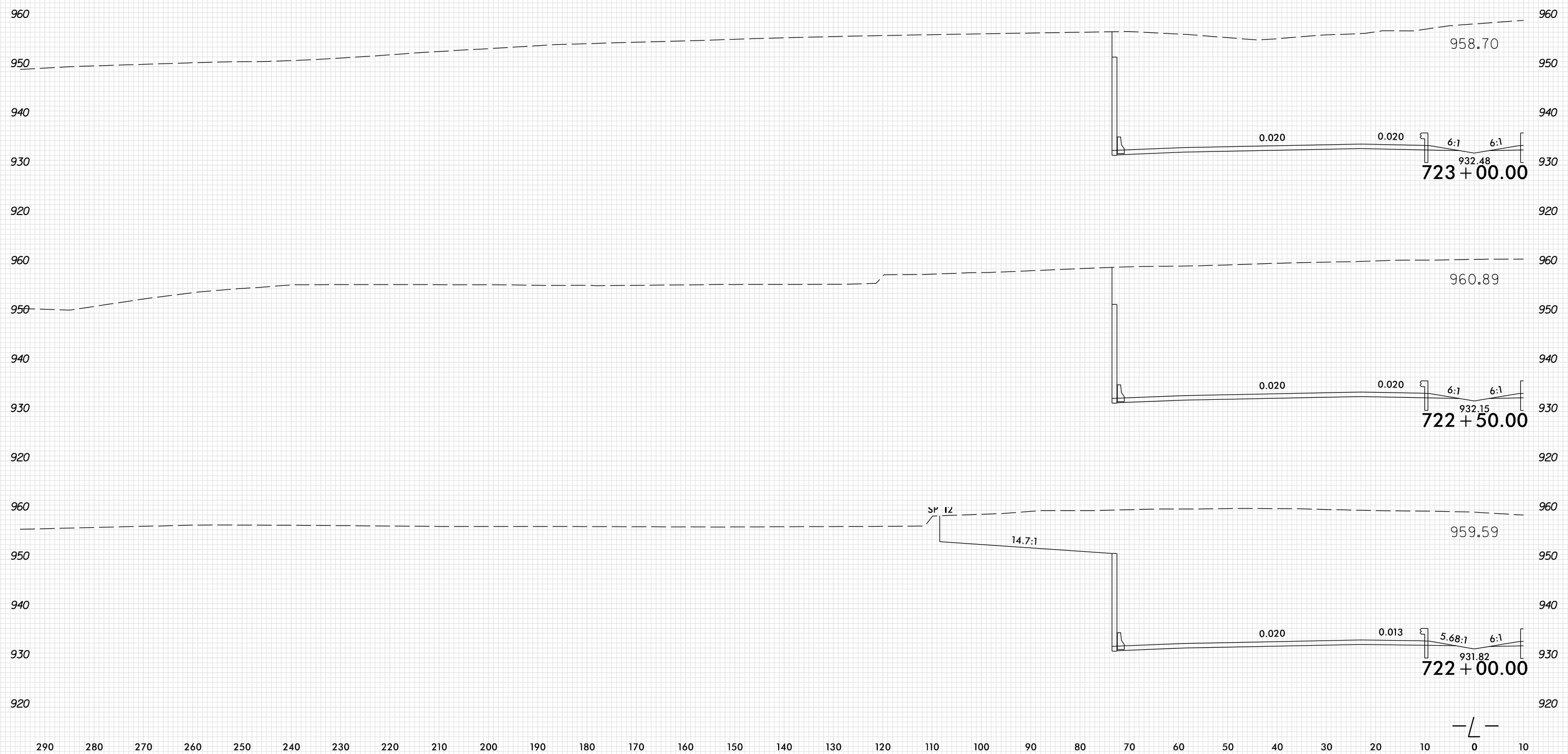

PLOT DRIVER: NCD01_pdf_color_eng_100.plt
 USER: SPEREIRA
 DATE: 6/10/2021
 TIME: 2:15:57 PM
 FILE: \

290 280 270 260 250 240 230 220 210 200 190 180 170 160 150 140 130 120 110 100 90 80 70 60 50 40 30 20 10 0 10

8/23/99

0 5 10	PROJ. REFERENCE NO.	SHEET NO.
	U-2579AB	X-20

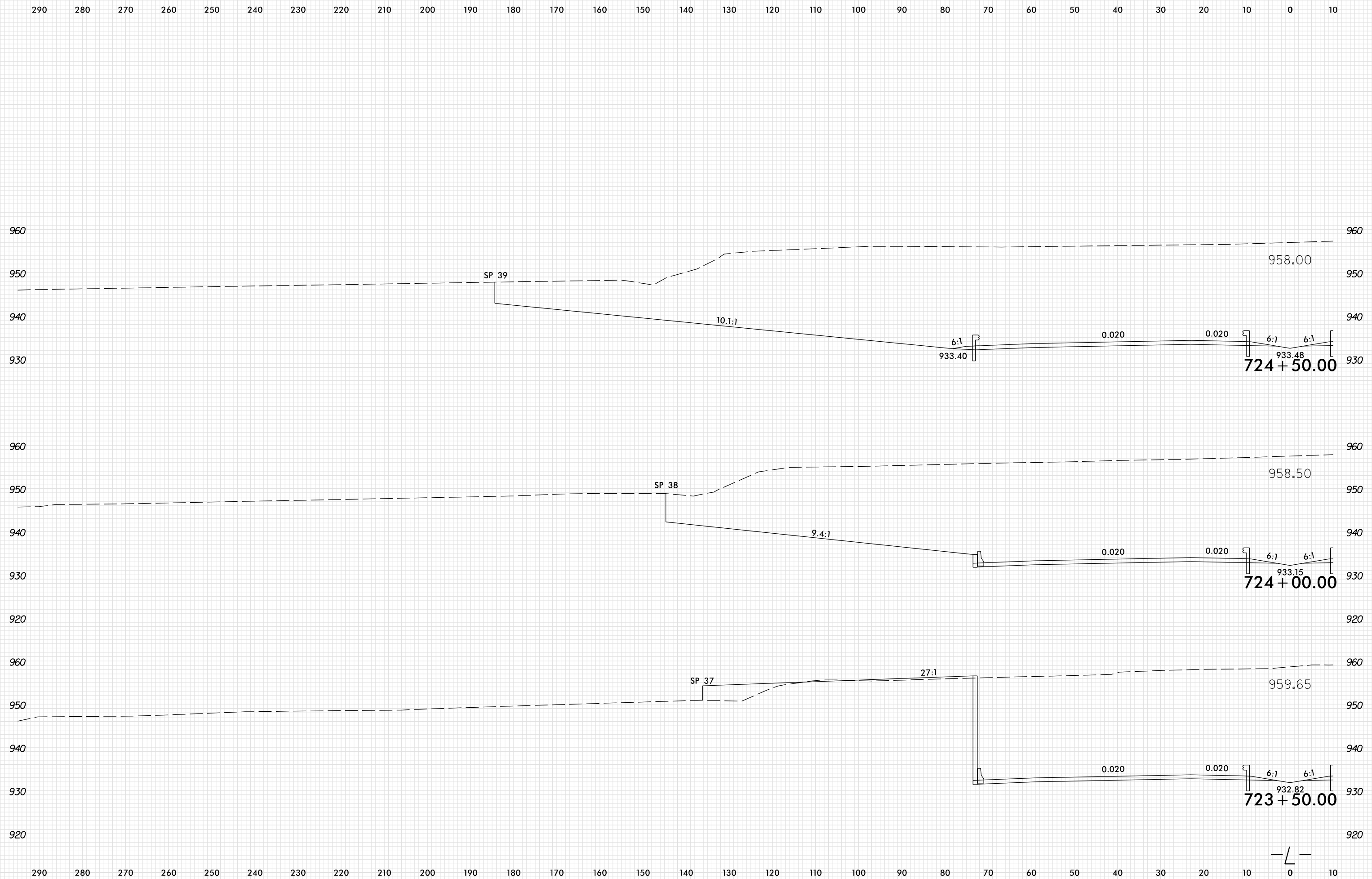

PLOT DRIVER: NCDOT_pdf_color_eng_100.plt
 USER: SPEREIRA
 DATE: 6/10/2021
 TIME: 2:15:58 PM
 FILE: \

8/23/99

290 280 270 260 250 240 230 220 210 200 190 180 170 160 150 140 130 120 110 100 90 80 70 60 50 40 30 20 10 0 10

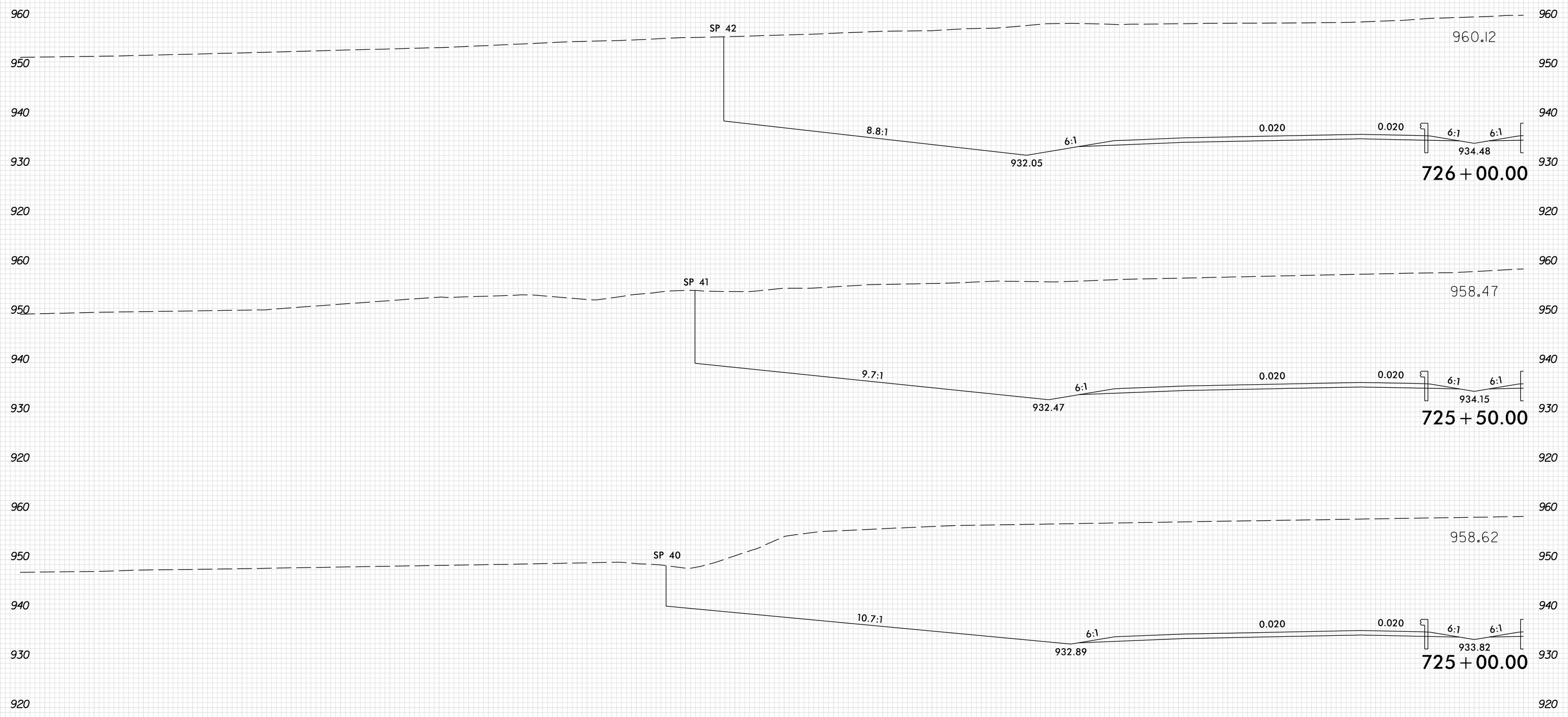

—/—

PLOT DRIVER: NCDOT_pdf_color_eng_100.plt
 USER: SPEREIRA
 DATE: 6/10/2021
 TIME: 2:15:59 PM
 FILE: \

8/23/99

0 5 10	PROJ. REFERENCE NO.	SHEET NO.
	U-2579AB	X-22

290 280 270 260 250 240 230 220 210 200 190 180 170 160 150 140 130 120 110 100 90 80 70 60 50 40 30 20 10 0 10

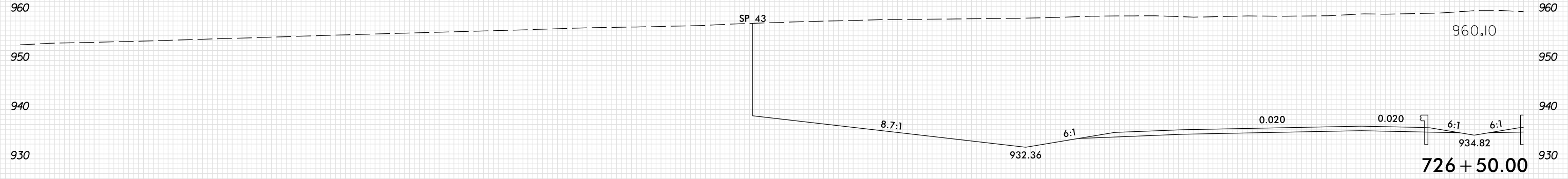
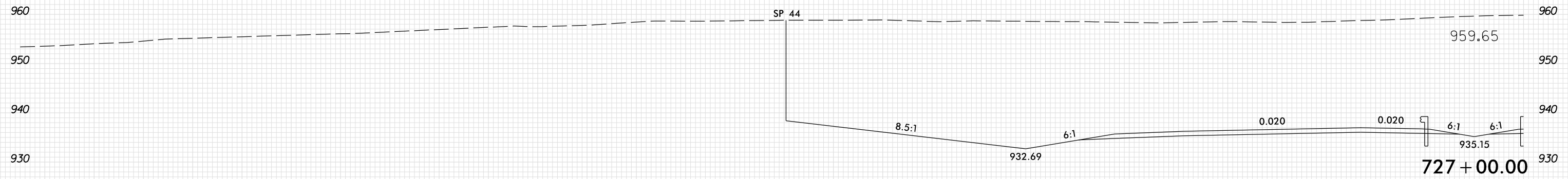
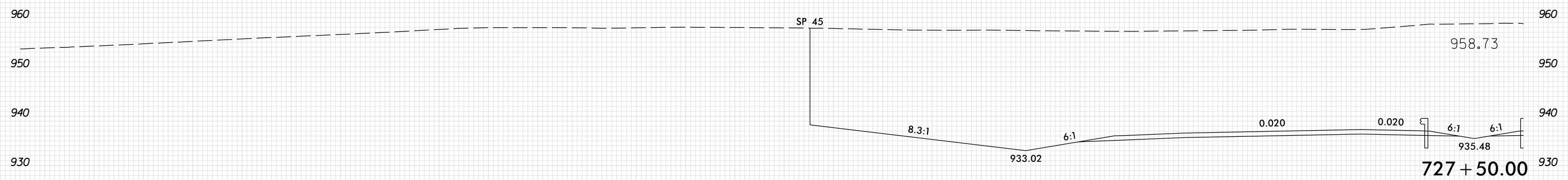

PLOT DRIVER: NCDOT_pdf_color_eng_100.plt
 USER: SPEREIRA
 DATE: 6/10/2021
 TIME: 2:16:00 PM
 FILE: \

290 280 270 260 250 240 230 220 210 200 190 180 170 160 150 140 130 120 110 100 90 80 70 60 50 40 30 20 10 0 10

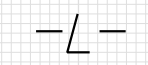

8/23/99

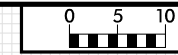

PROJ. REFERENCE NO.	SHEET NO.
U-2579AB	X-23

290 280 270 260 250 240 230 220 210 200 190 180 170 160 150 140 130 120 110 100 90 80 70 60 50 40 30 20 10 0 10

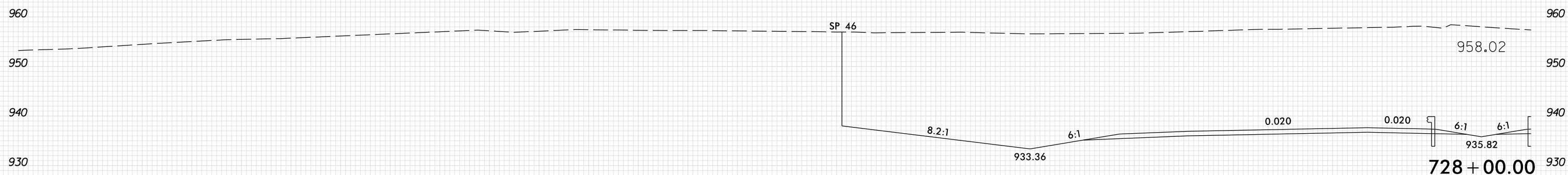
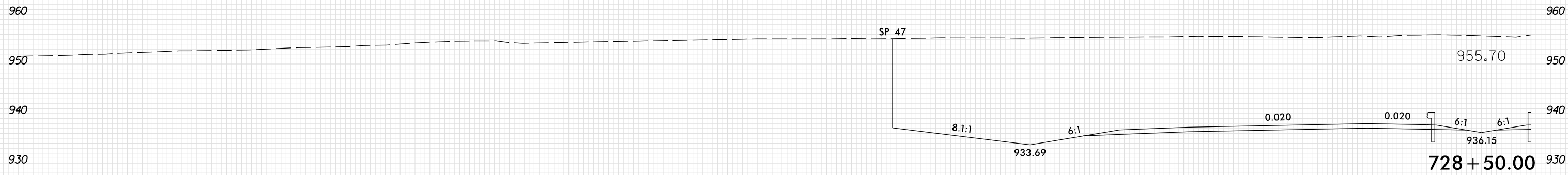
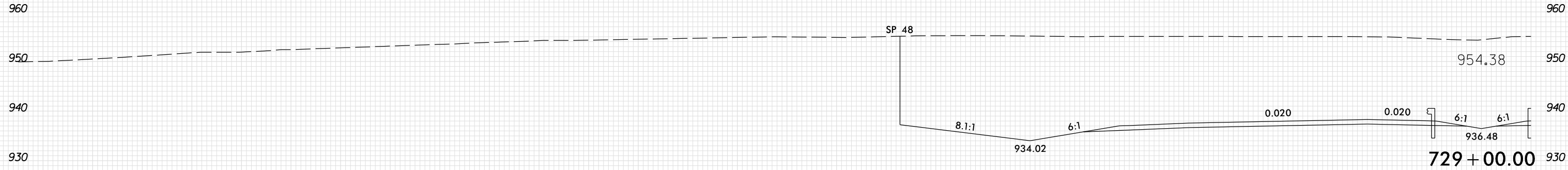

290 280 270 260 250 240 230 220 210 200 190 180 170 160 150 140 130 120 110 100 90 80 70 60 50 40 30 20 10 0 10

PLOT DRIVER: NCDOT_pdf_color_eng_100.plt
 USER: SPEREIRA
 DATE: 6/10/2021
 TIME: 2:16:00 PM
 FILE: \

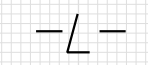

8/23/99

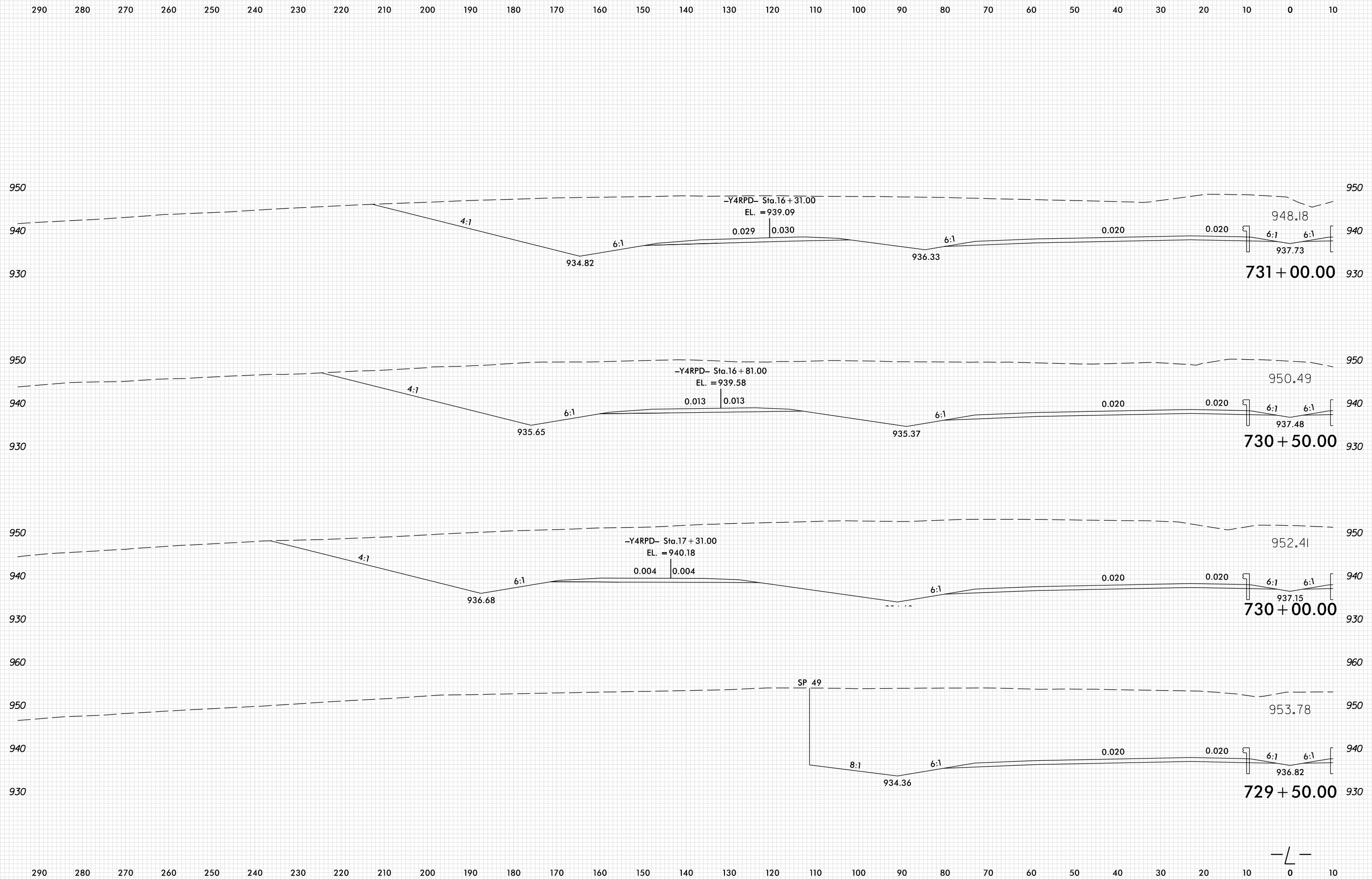

PLOT DRIVER: NCD01_pdf_color_eng_100.plt
 USER: SPEREIRA
 DATE: 6/10/2021
 TIME: 2:16:01 PM
 FILE: \

8/23/99

290 280 270 260 250 240 230 220 210 200 190 180 170 160 150 140 130 120 110 100 90 80 70 60 50 40 30 20 10 0 10

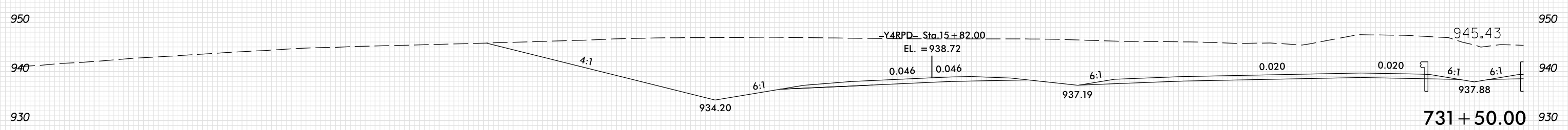
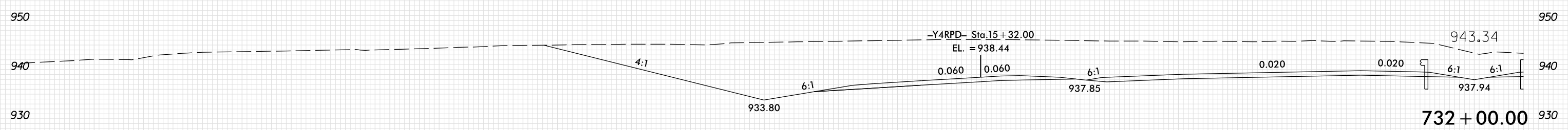
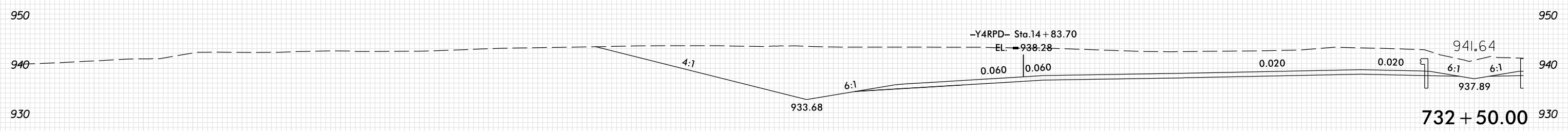
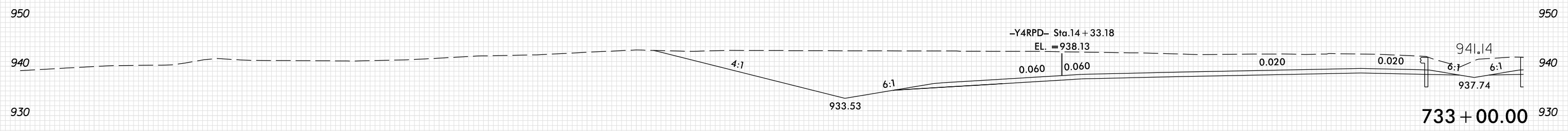

290 280 270 260 250 240 230 220 210 200 190 180 170 160 150 140 130 120 110 100 90 80 70 60 50 40 30 20 10 0 10

PLOT DRIVER: NCD01_pdf_color_eng_100.plt
USER: SPEREIRA
DATE: 6/10/2021
TIME: 2:16:01 PM

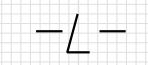

8/23/99

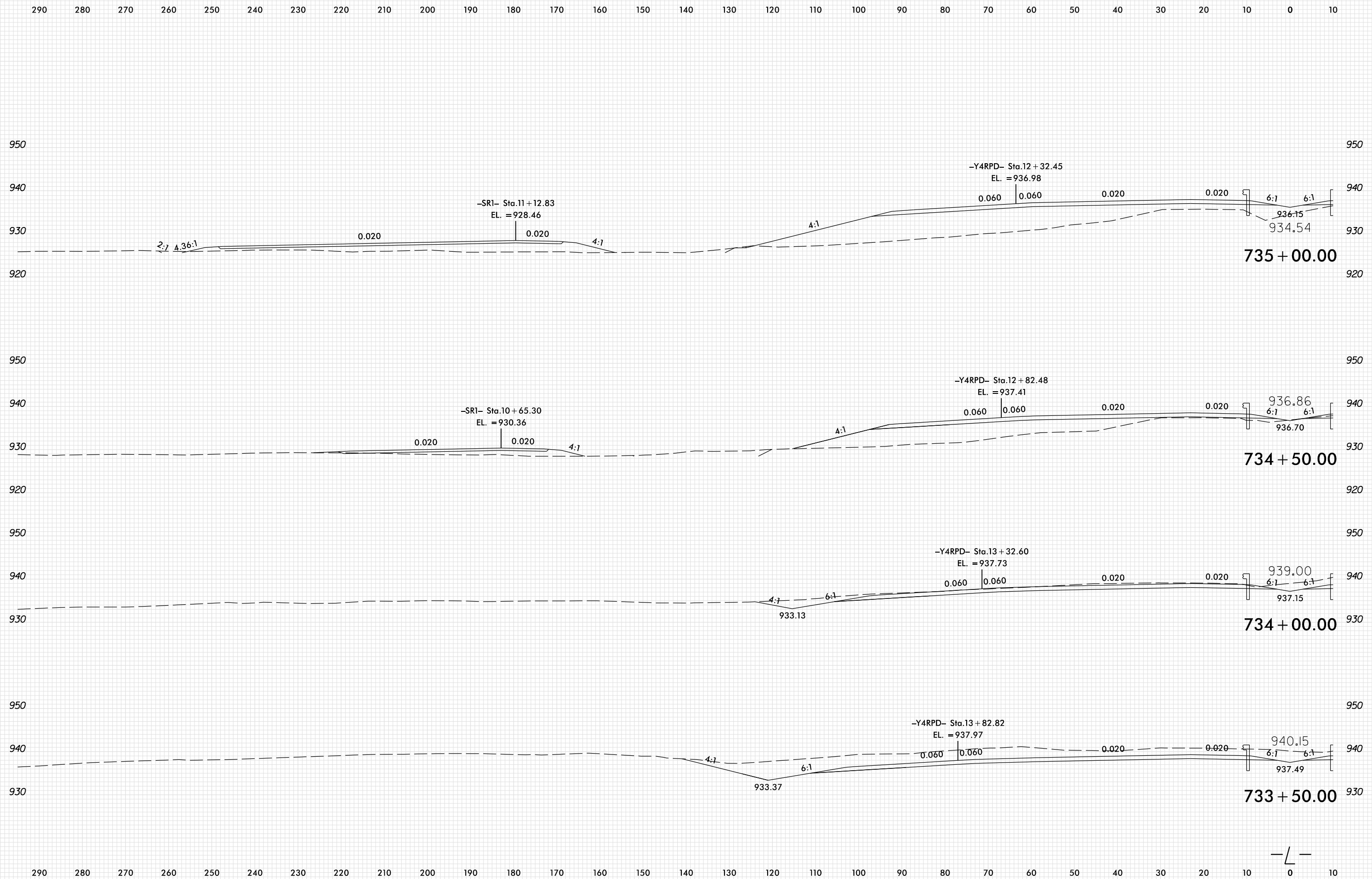

PLOT DRIVER: NCD01_pdf_color_eng_100.plt
 USER: SPEREIRA
 DATE: 6/10/2021
 TIME: 2:16:02 PM
 FILE: \

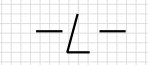

8/23/99

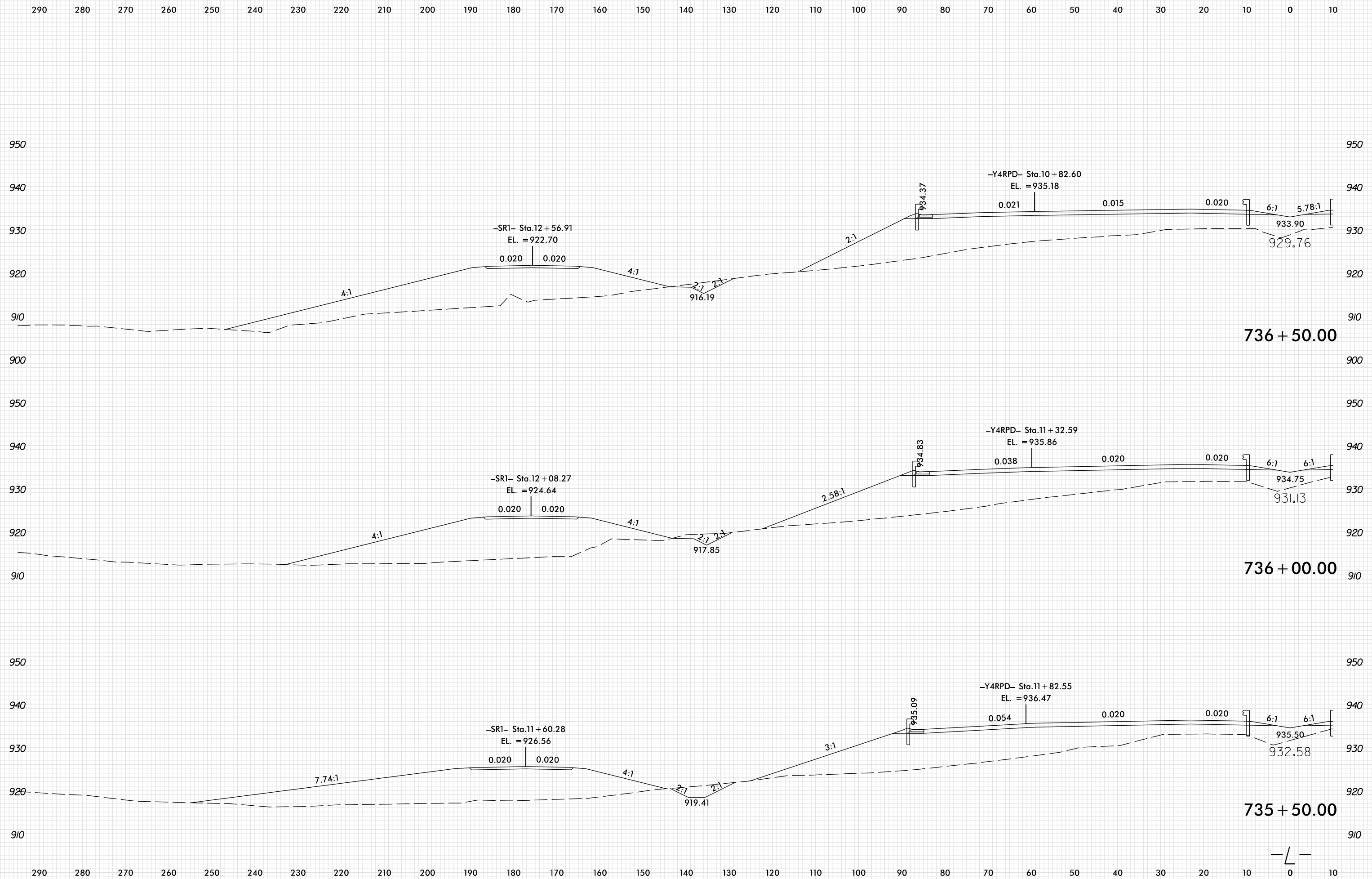

PLOT DRIVER: NCDOT_pdf_color_eng_100.plt
 USER: SPEREIRA
 DATE: 6/10/2021
 TIME: 2:16:02 PM
 FILE: \

8/23/99

0 5 10	PROJ. REFERENCE NO.	SHEET NO.
	U-2579AB	X-28

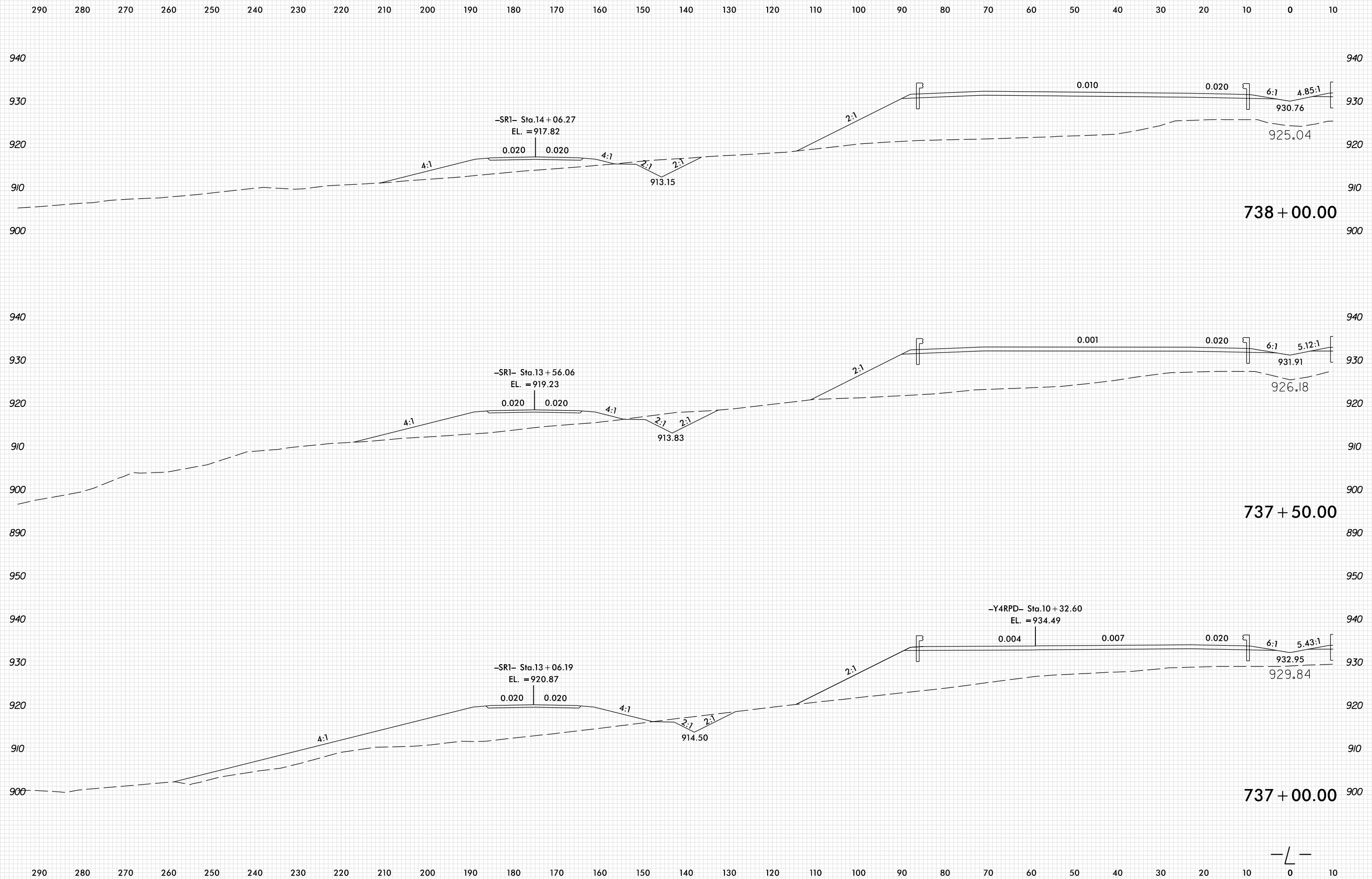

PLOT DRIVER: NCDOT_pdf_color_eng_100.plt
 USER: SPEREIRA
 DATE: 6/10/2021
 TIME: 2:16:03 PM
 FILE: \

8/23/99

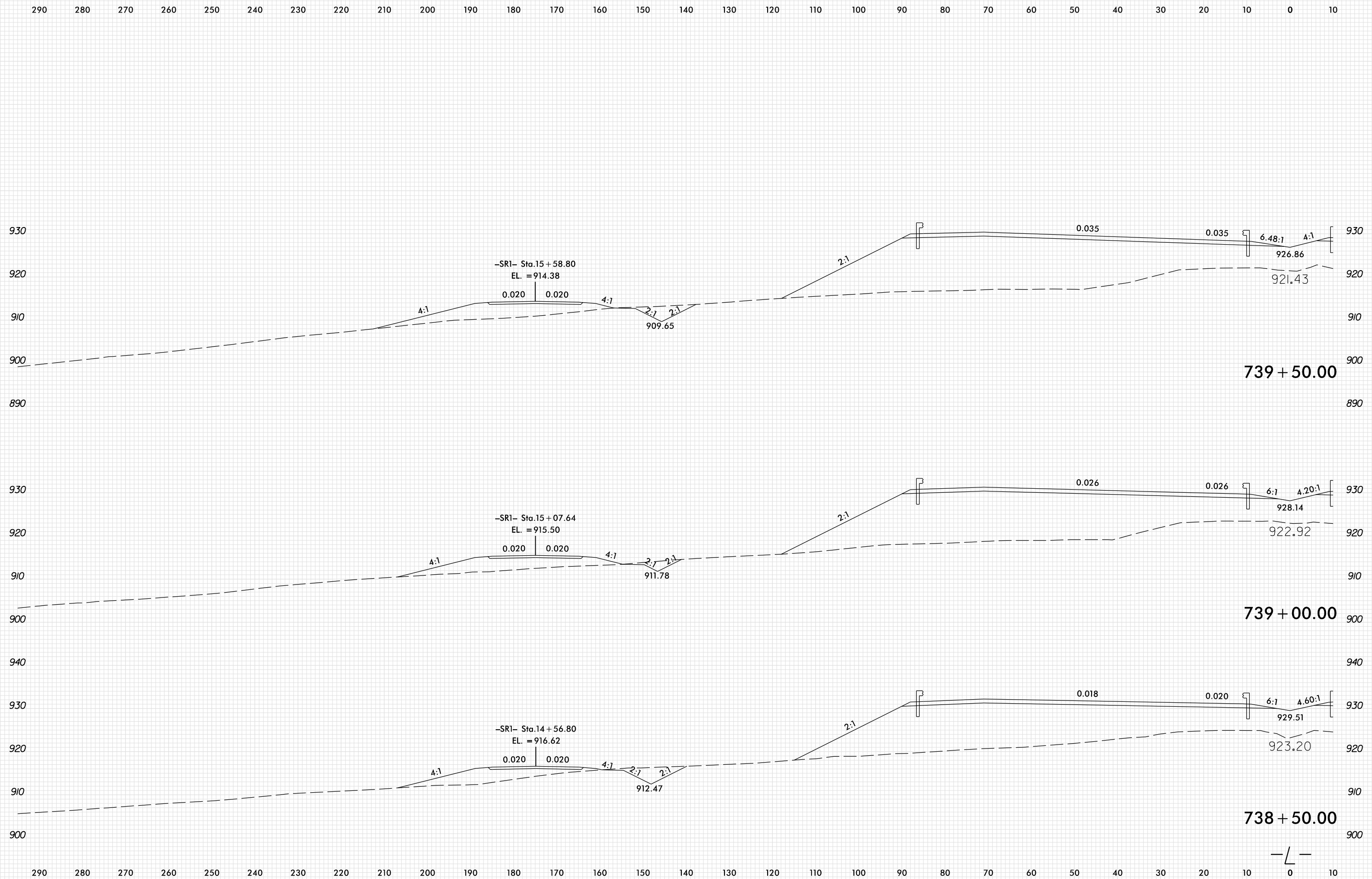

PLOT DRIVER: NCDOT_pdf_color_eng_100.plt
 USER: SPEREIRA
 DATE: 6/10/2021
 TIME: 2:16:04 PM
 FILE: \

8/23/99

0 5 10	PROJ. REFERENCE NO.	SHEET NO.
	U-2579AB	X-30

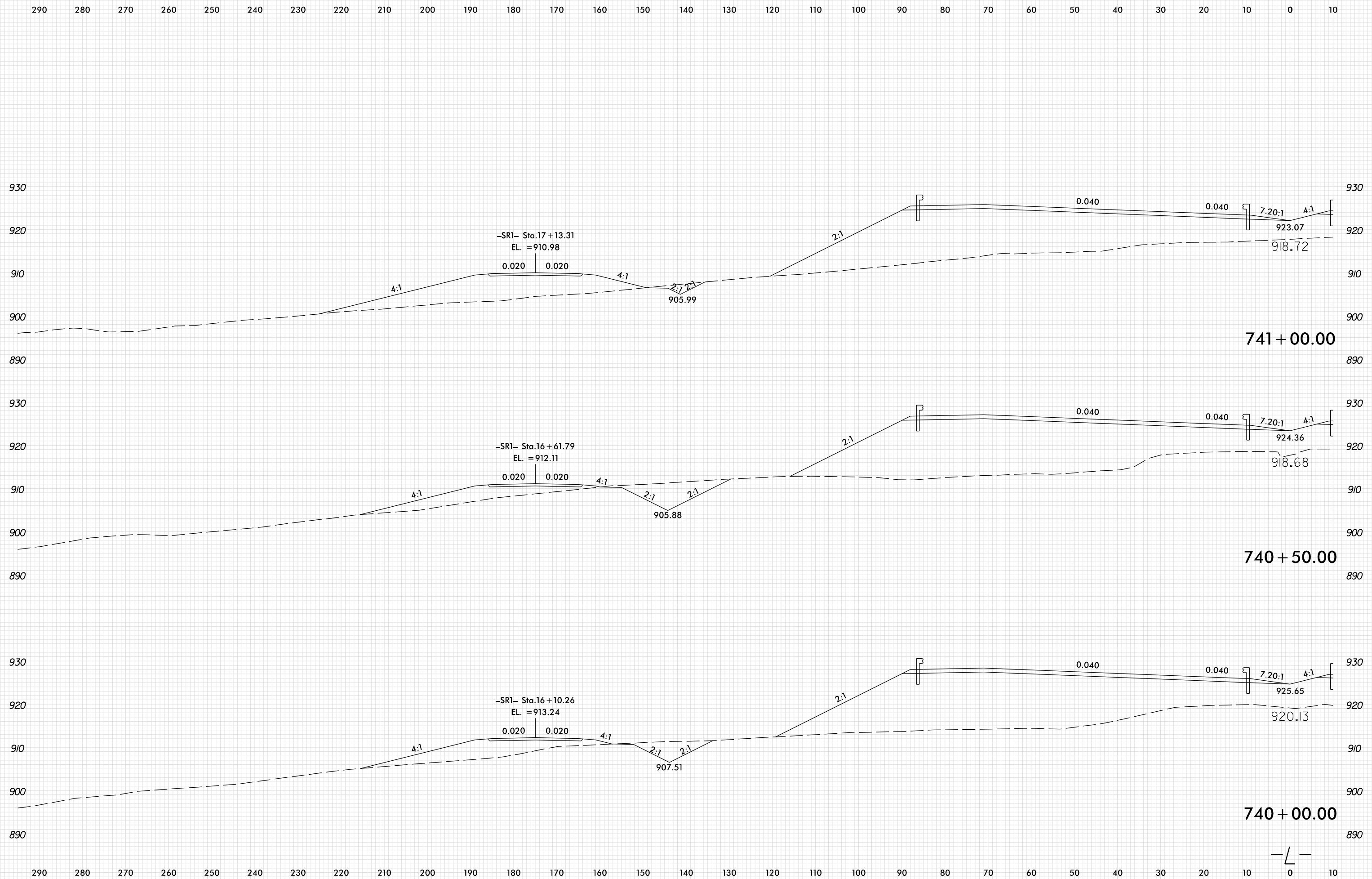

PLOT DRIVER: NCD01_pdf_color_eng_100.plt
 USER: SPEREIRA
 DATE: 6/10/2021
 TIME: 2:16:04 PM
 FILE: \

8/23/99

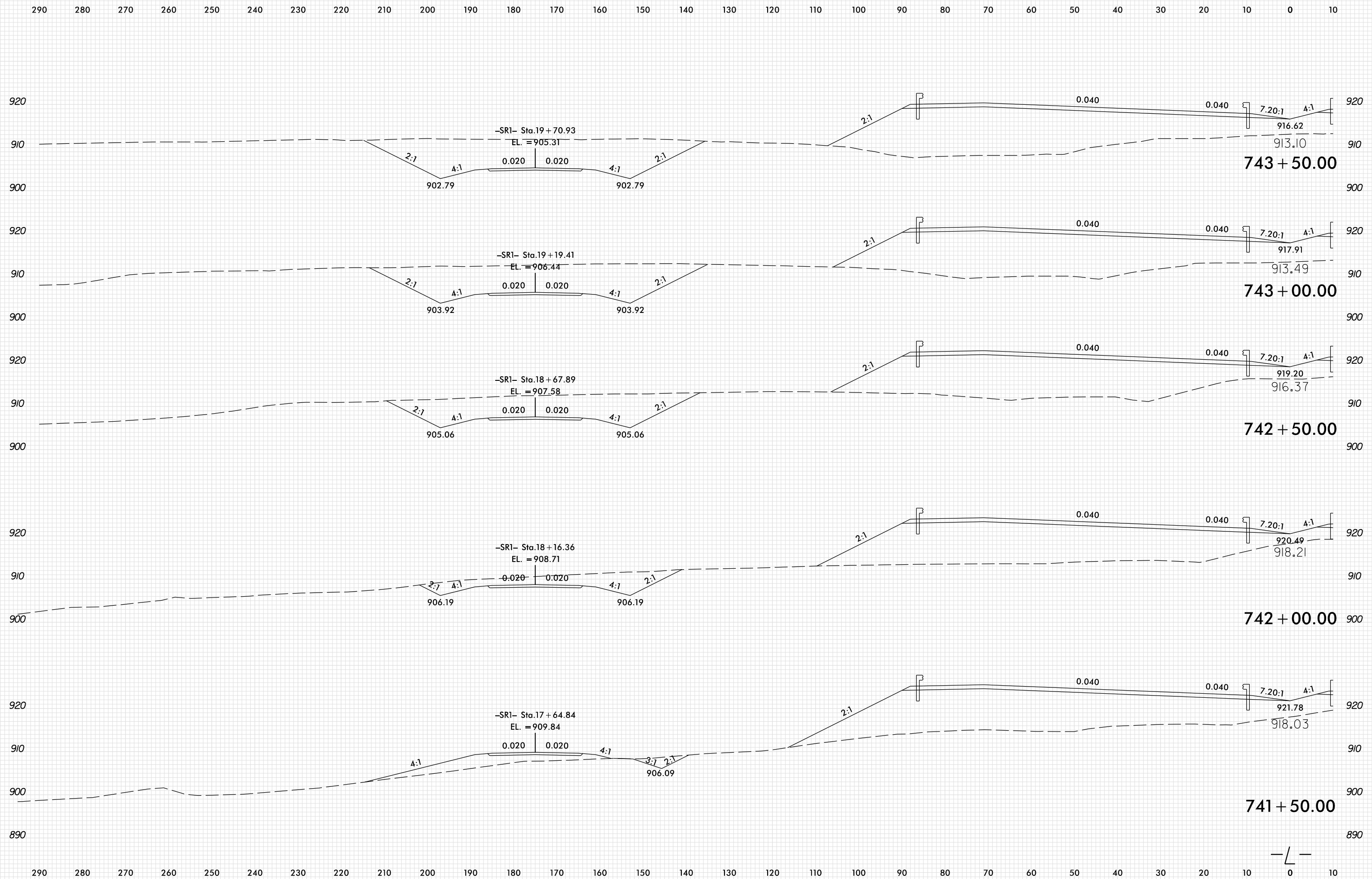

PLOT DRIVER: NCD01_pdf_color_eng_100.plt
 USER: SPEREIRA
 DATE: 6/10/2021
 TIME: 2:16:05 PM

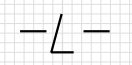

8/23/99

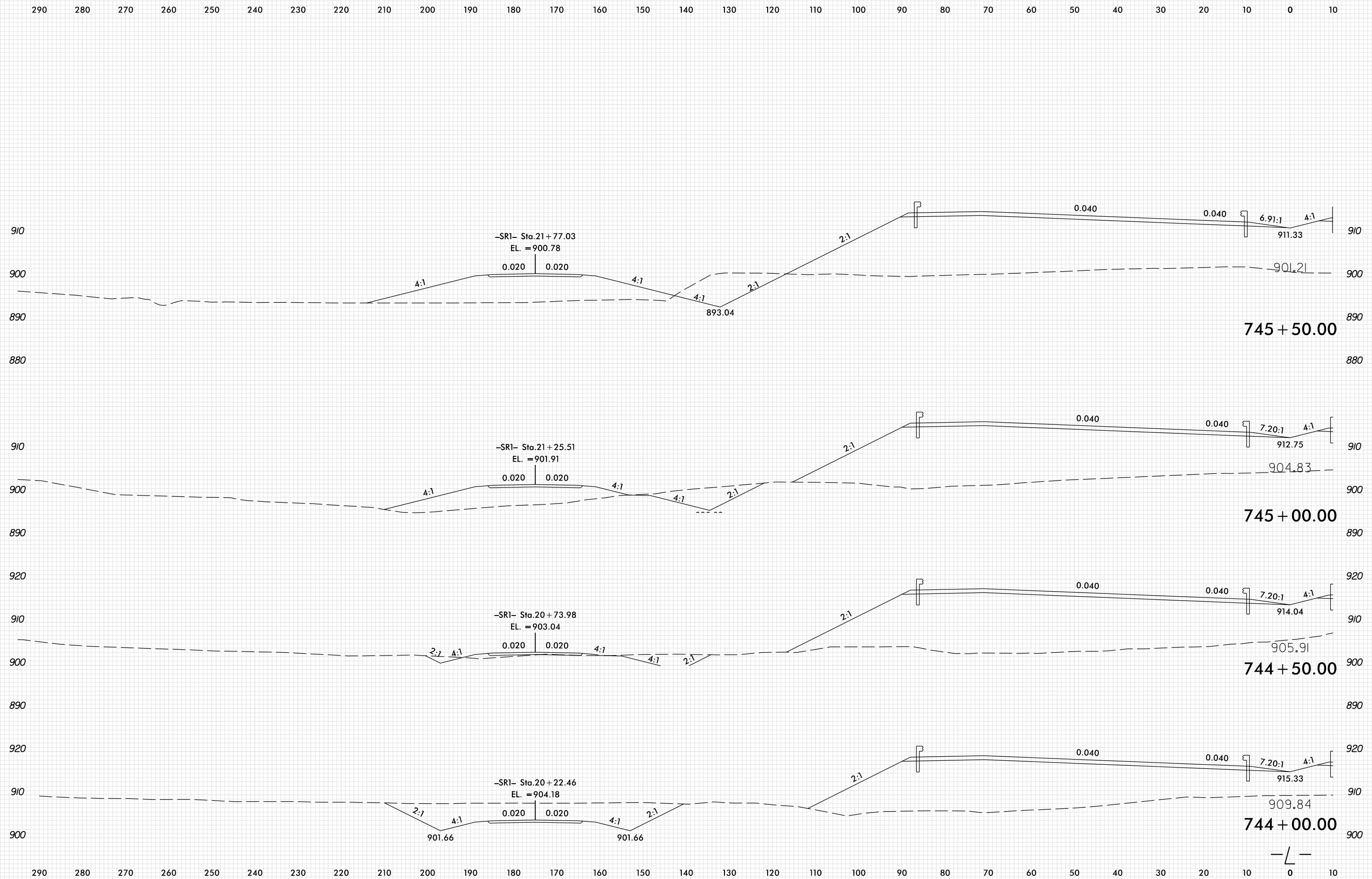

PLOT DRIVER: NCD01_pdf_color_eng_100.plt
 USER: SPEREIRA
 DATE: 6/10/2021
 TIME: 2:16:06 PM
 FILE: \

8/23/99

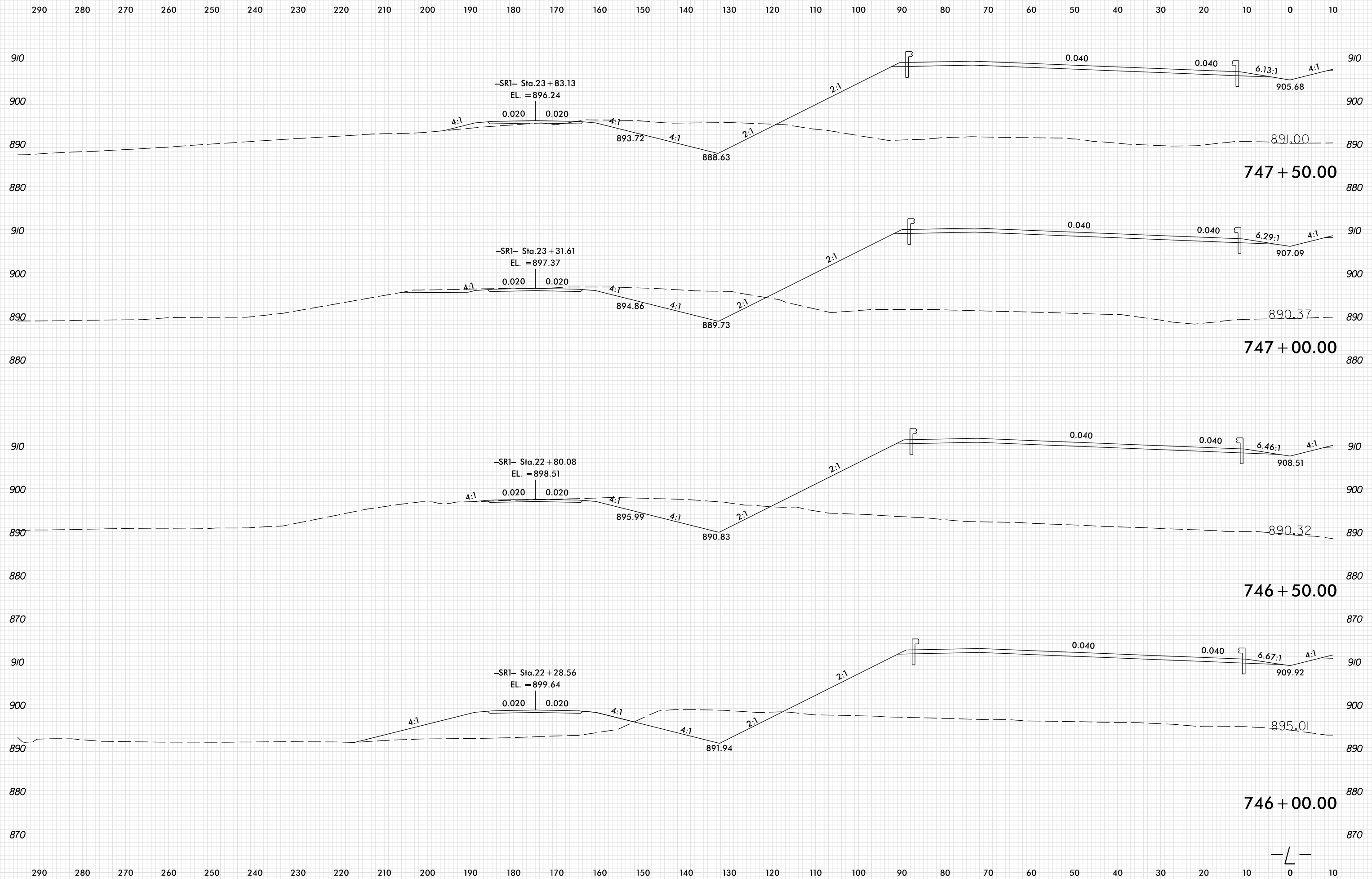

PLOT DRIVER: NCDOT_pdf_color_eng_100.plt
 USER: SPEREIRA
 DATE: 6/10/2021
 TIME: 2:16:06 PM
 FILE: \

8/23/99

0 5 10	PROJ. REFERENCE NO.	SHEET NO.
	U-2579AB	X-34

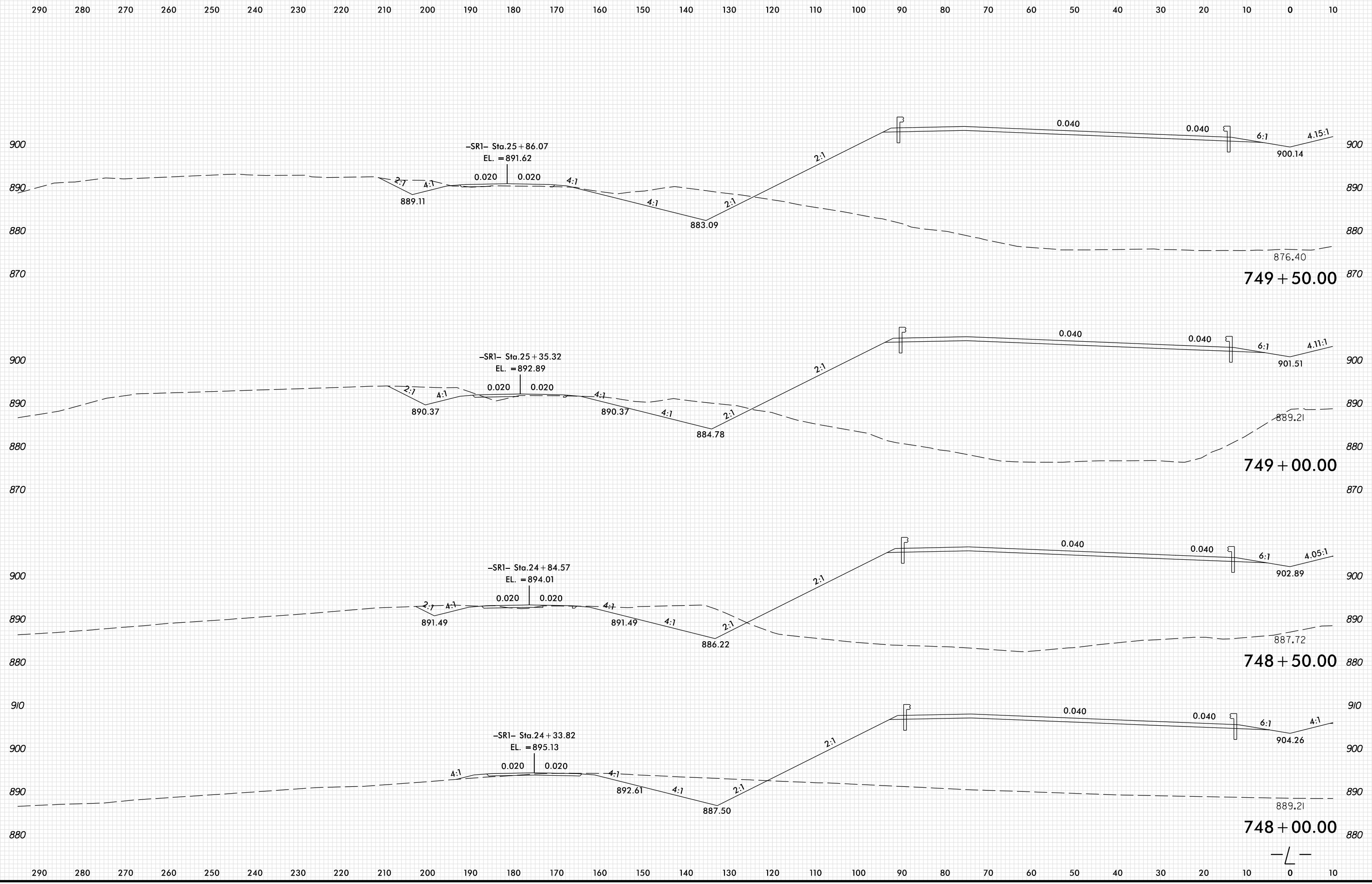

PLOT DRIVER: NCD01_pdf_color_eng_100.plt
 USER: SPEREIRA
 DATE: 6/10/2021
 TIME: 2:16:07 PM

8/23/99

0 5 10	PROJ. REFERENCE NO.	SHEET NO.
	U-2579AB	X-35

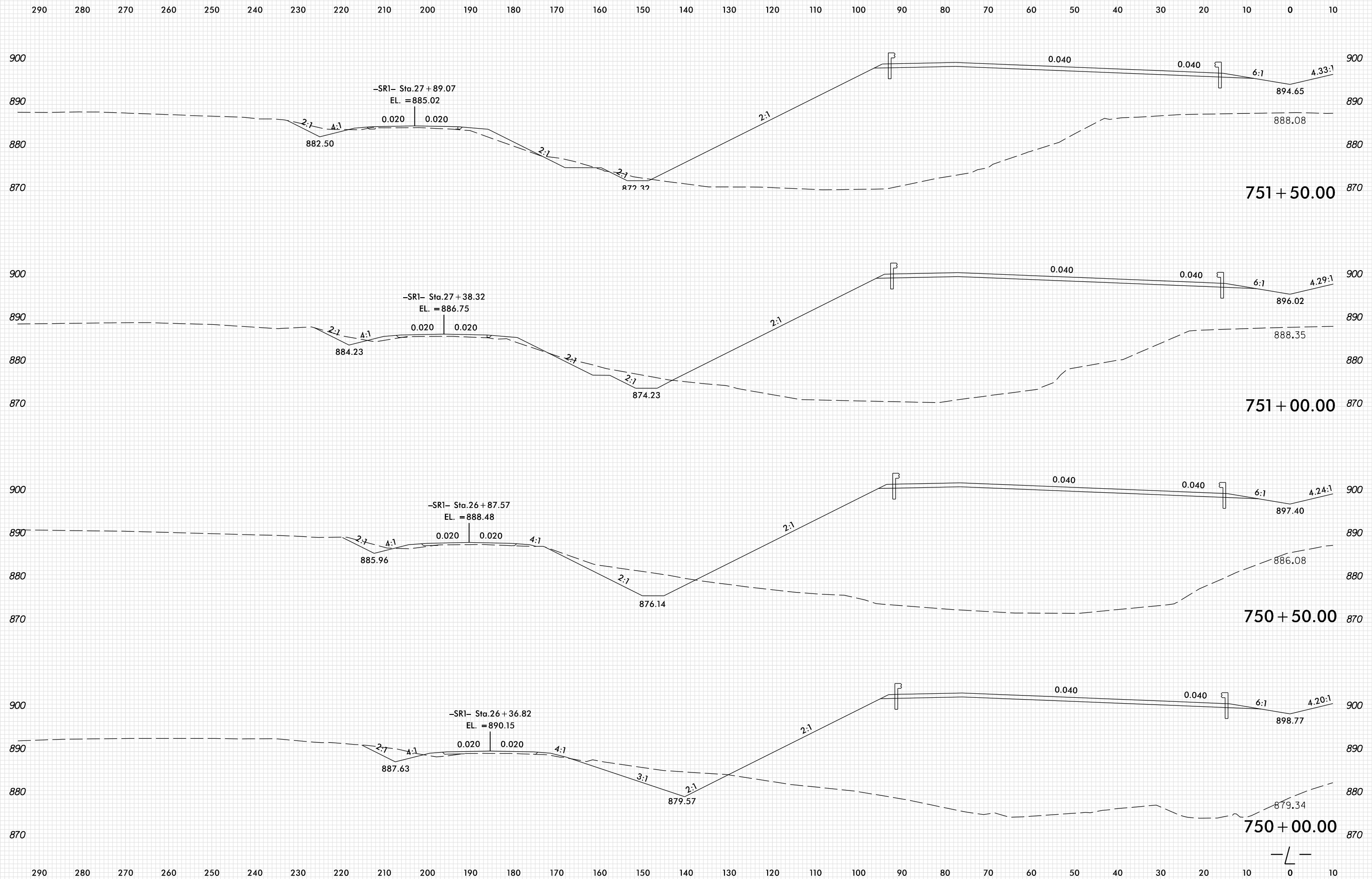

PLOT DRIVER: NCDOT_pdf_color_eng_100.plt
 USER: SPEREIRA
 DATE: 6/10/2021
 TIME: 2:16:07 PM
 FILE: \

8/23/99

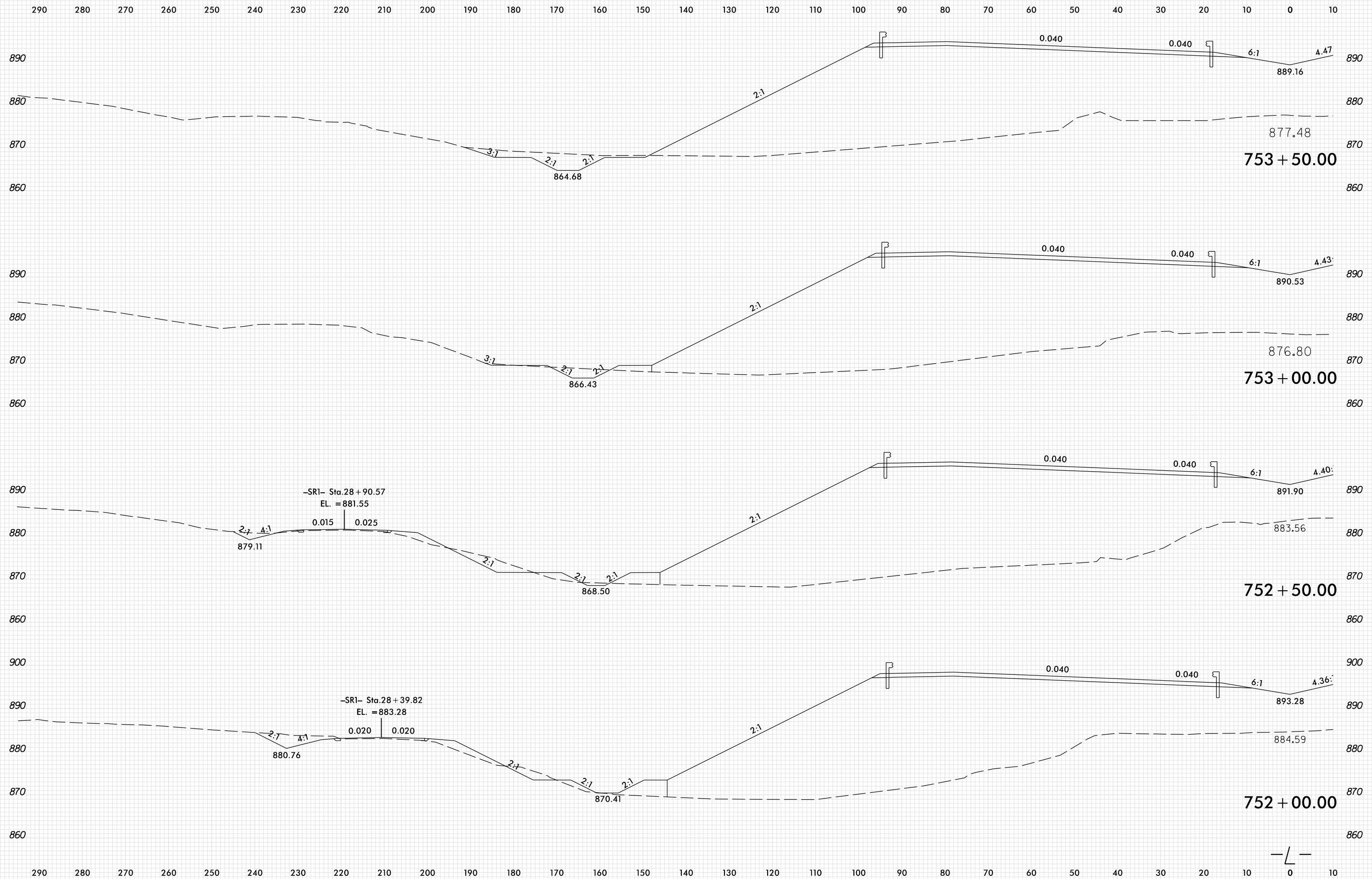

PLOT DRIVER: NCDOT_pdf_color_eng_100.plt
 USER: SPEREIRA
 DATE: 6/10/2021
 TIME: 2:16:08 PM
 FILE: \

8/23/99

0 5 10	PROJ. REFERENCE NO.	SHEET NO.
	U-2579AB	X-37

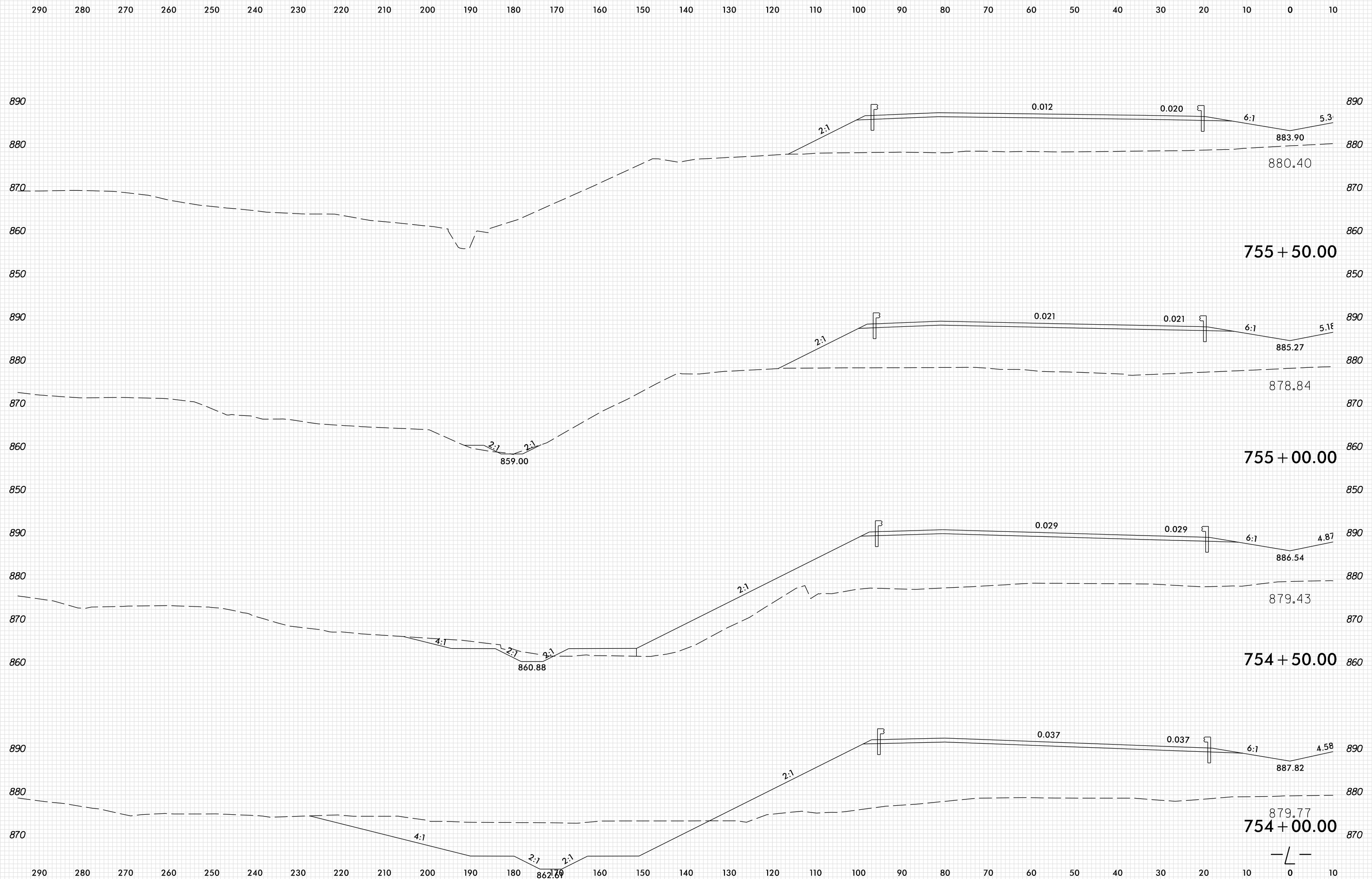

PLOT DRIVER: NCD01_pdf_color_eng_100.plt
 USER: SPEREIRA
 DATE: 6/10/2021
 TIME: 2:16:08 PM
 FILE: \

8/23/99

0 5 10	PROJ. REFERENCE NO.	SHEET NO.
	U-2579AB	X-38

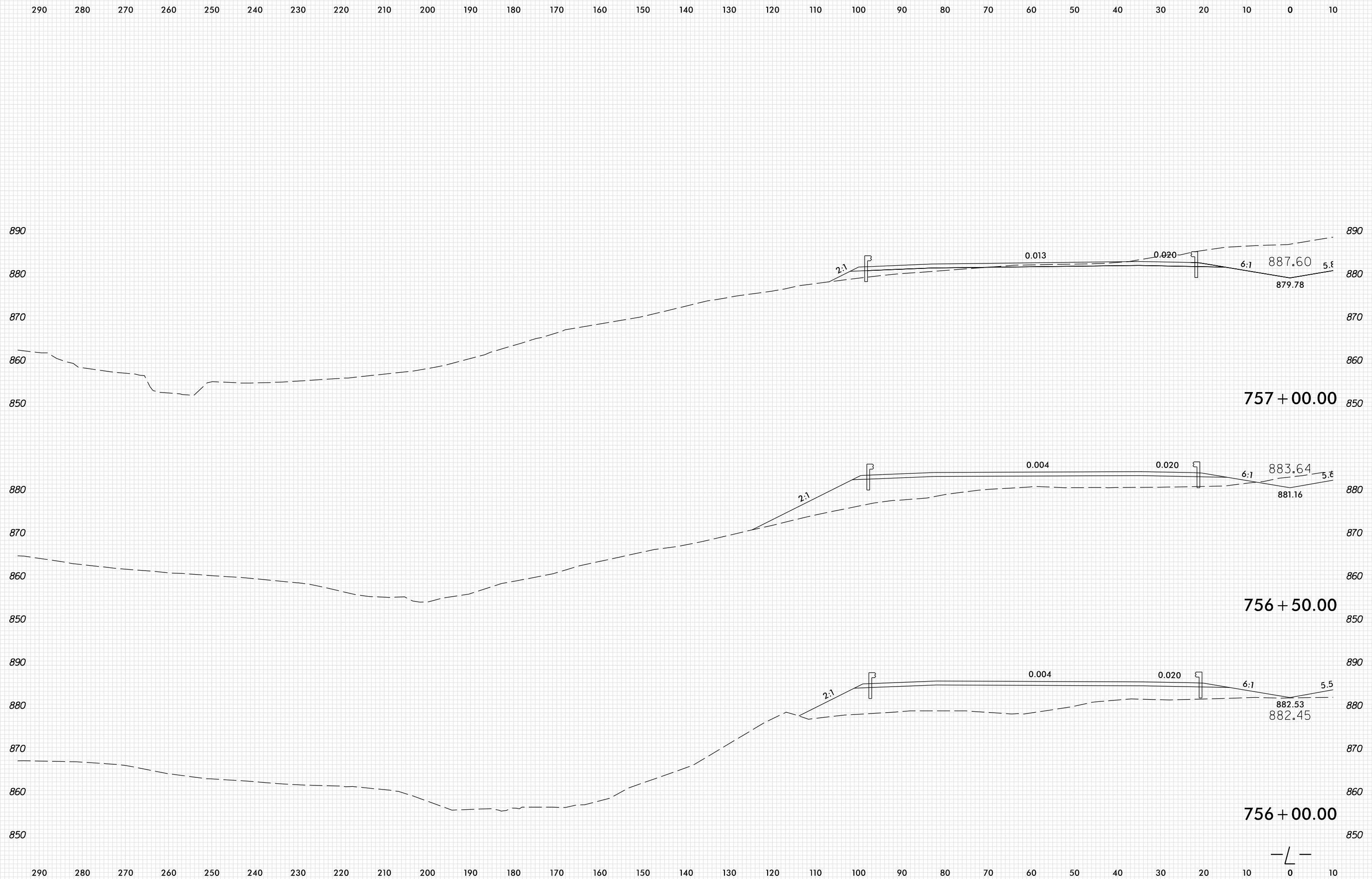

PLOT DRIVER: NCDOT_pdf_color_eng_100.plt
 USER: SPEREIRA
 DATE: 6/10/2021
 TIME: 2:16:09 PM
 FILE: \

8/23/99

0 5 10	PROJ. REFERENCE NO.	SHEET NO.
	U-2579AB	X-39

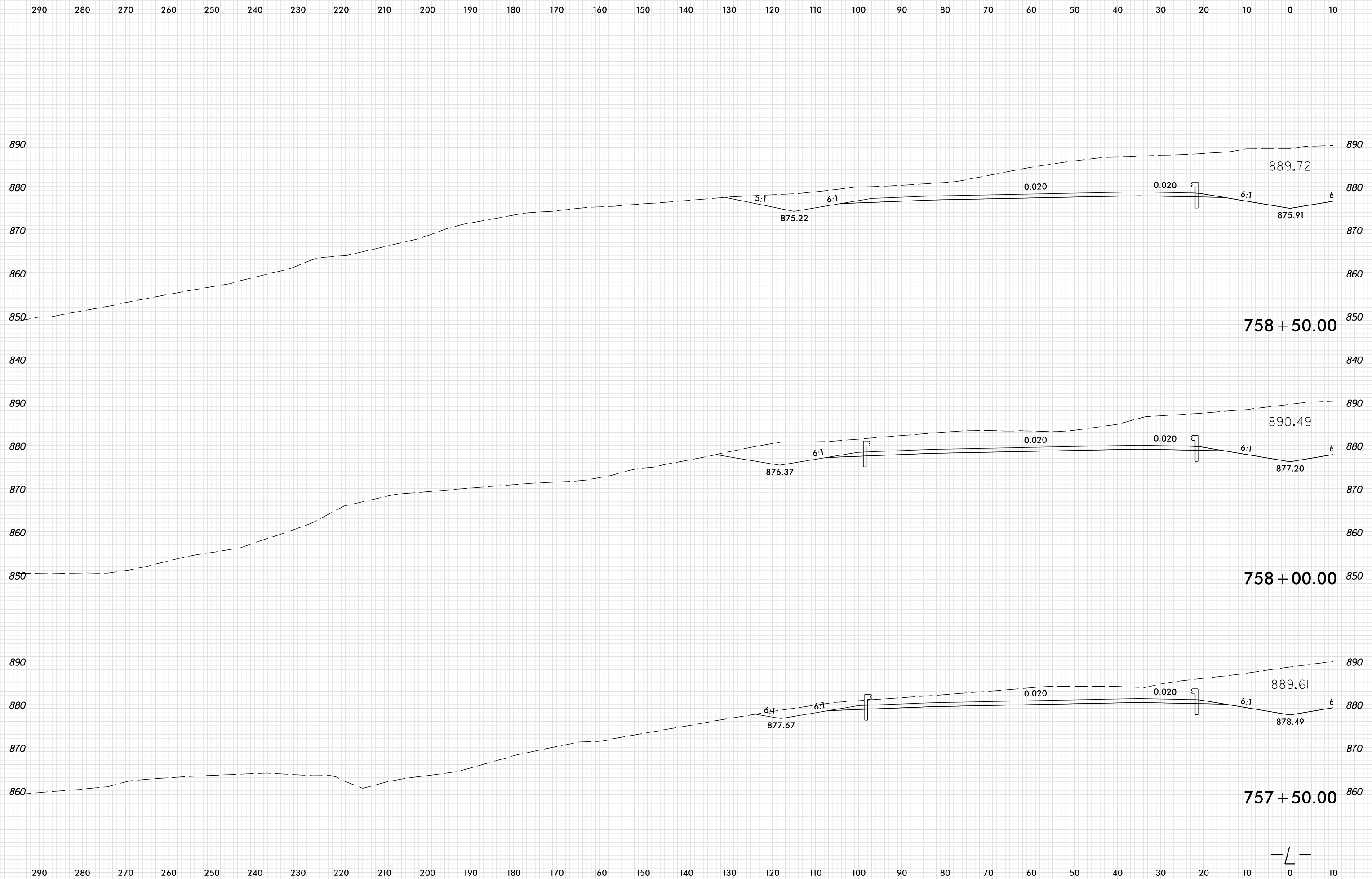

PLOT DRIVER: NCDOT_pdf_color_eng_100.plt
 USER: SPEREIRA
 DATE: 6/10/2021
 TIME: 2:16:10 PM
 FILE: \

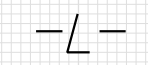

8/23/99

0 5 10	PROJ. REFERENCE NO.	SHEET NO.
	U-2579AB	X-40

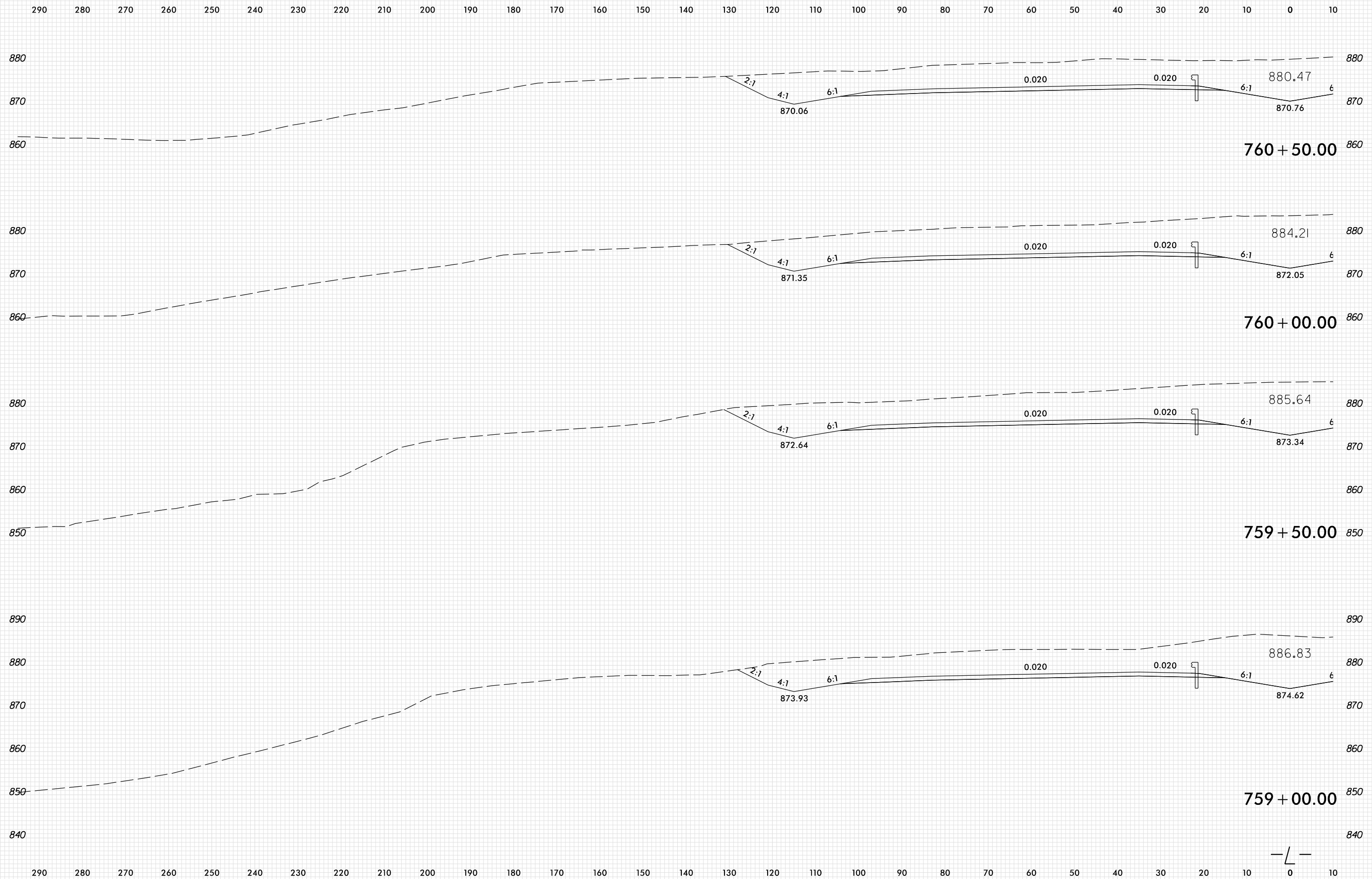

PLOT DRIVER: NCDOT_pdf_color_eng_100.plt
 USER: SPEREIRA
 DATE: 6/10/2021
 TIME: 2:16:10 PM
 FILE: \

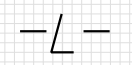

8/23/99

0 5 10	PROJ. REFERENCE NO.	SHEET NO.
	U-2579AB	X-41

290 280 270 260 250 240 230 220 210 200 190 180 170 160 150 140 130 120 110 100 90 80 70 60 50 40 30 20 10 0 10

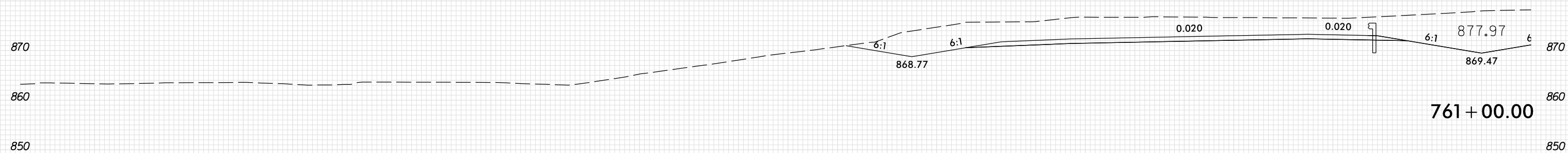
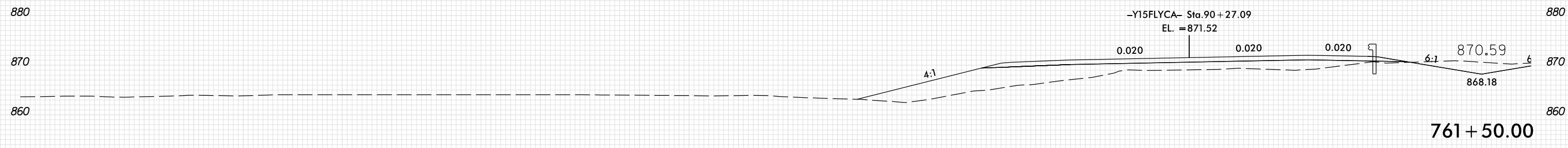
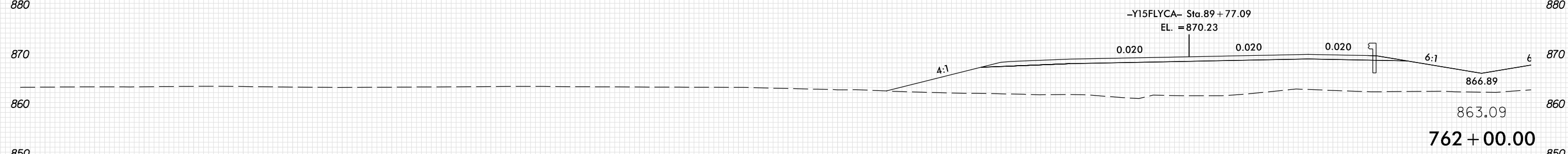
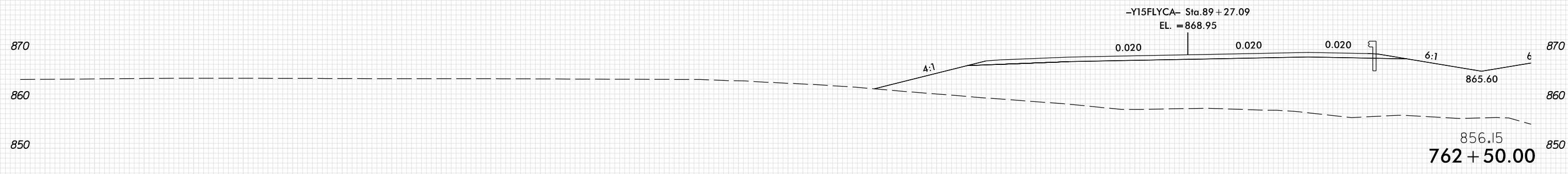

290 280 270 260 250 240 230 220 210 200 190 180 170 160 150 140 130 120 110 100 90 80 70 60 50 40 30 20 10 0 10

PLOT DRIVER: NCD01_pdf_color_eng_100.plt
USER: SPEREIRA
DATE: 6/10/2021
TIME: 2:16:11 PM
FILE: \

8/23/99

290 280 270 260 250 240 230 220 210 200 190 180 170 160 150 140 130 120 110 100 90 80 70 60 50 40 30 20 10 0 10

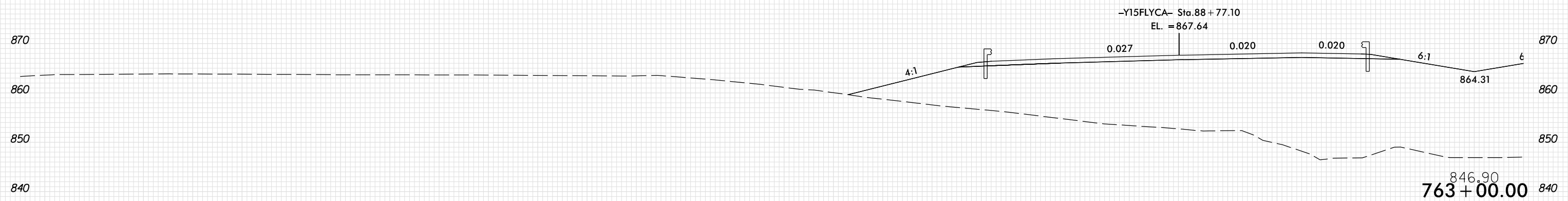
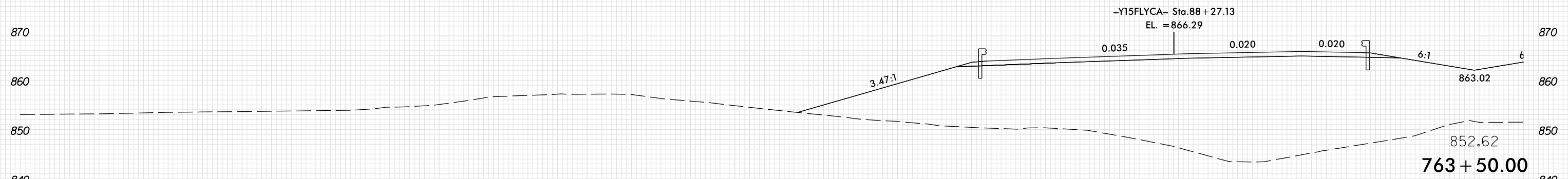
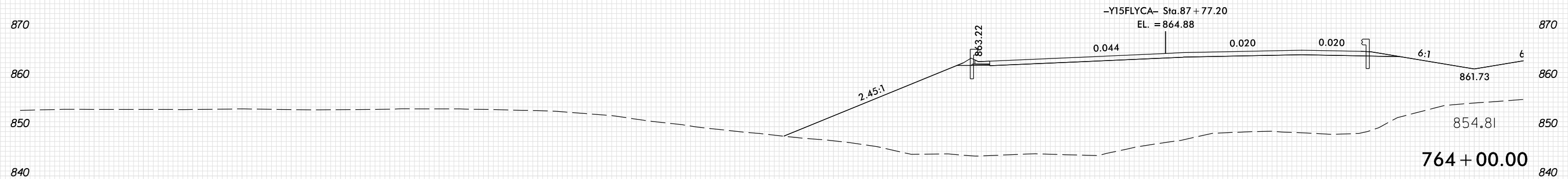

290 280 270 260 250 240 230 220 210 200 190 180 170 160 150 140 130 120 110 100 90 80 70 60 50 40 30 20 10 0 10

PLOT DRIVER: NCDOT_pdf_color_eng_100.plt
USER: SPEREIRA
DATE: 6/10/2021
TIME: 2:16:11 PM
FILE: \

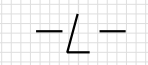

8/23/99

0 5 10	PROJ. REFERENCE NO.	SHEET NO.
	U-2579AB	X-43

290 280 270 260 250 240 230 220 210 200 190 180 170 160 150 140 130 120 110 100 90 80 70 60 50 40 30 20 10 0 10

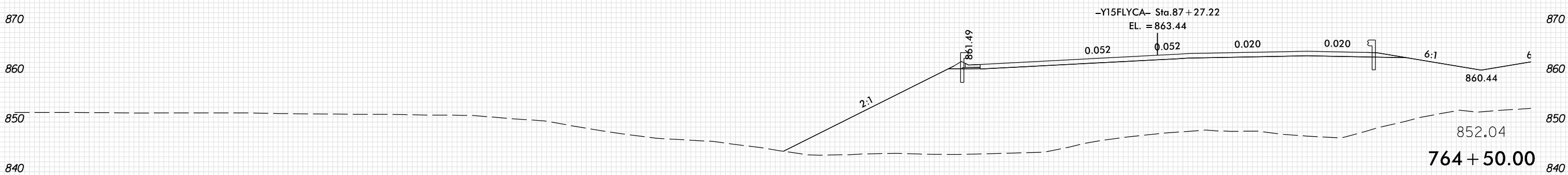
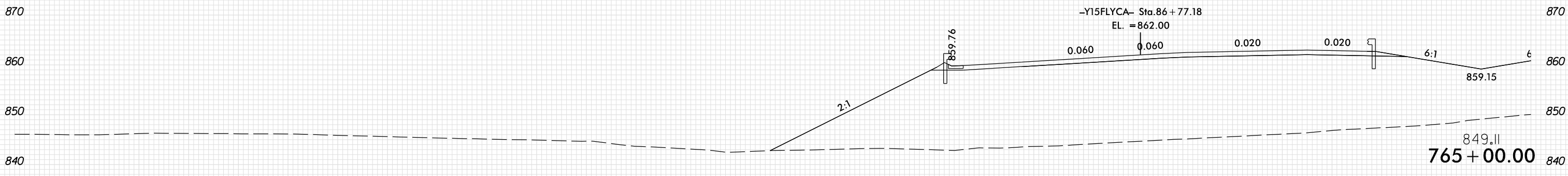
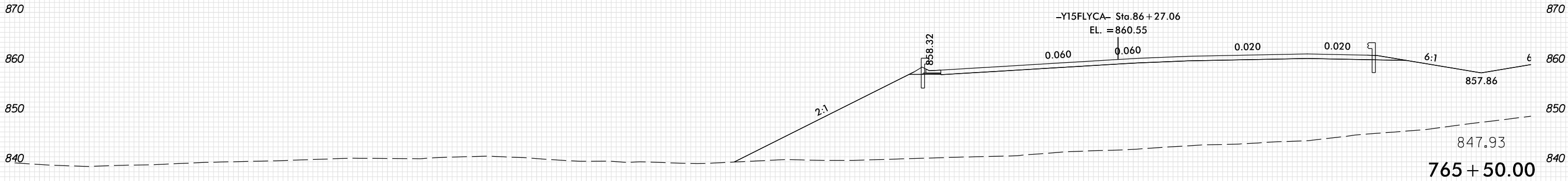
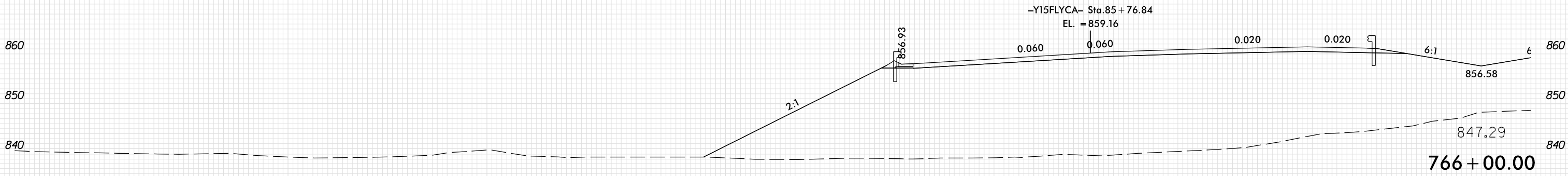

290 280 270 260 250 240 230 220 210 200 190 180 170 160 150 140 130 120 110 100 90 80 70 60 50 40 30 20 10 0 10

PLOT DRIVER: NCDOT_pdf_color_eng_100.plt
 USER: SPEREIRA
 DATE: 6/10/2021
 TIME: 2:16:12 PM
 FILE: \

8/23/99

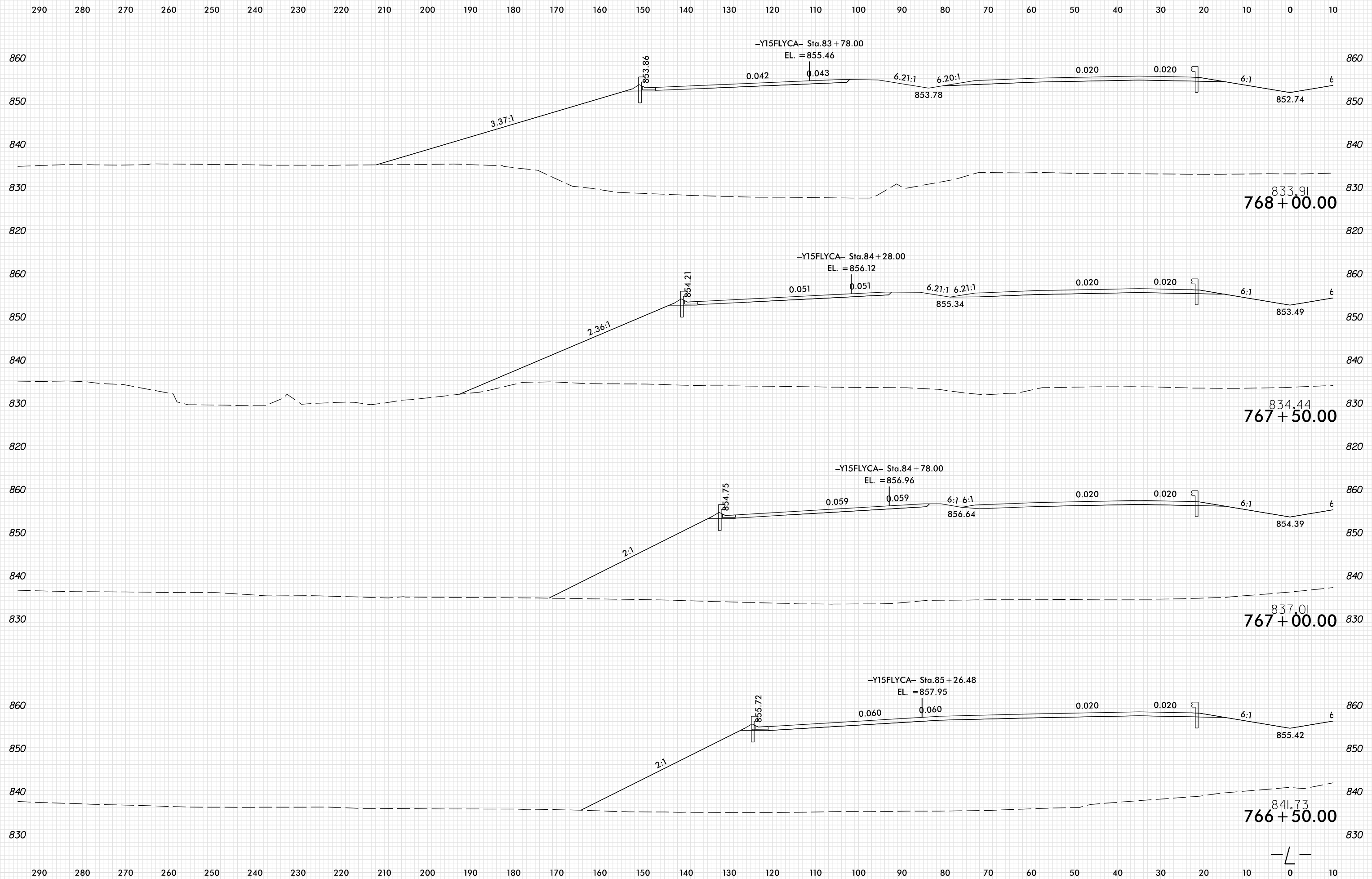

PLOT DRIVER: NCDOT_pdf_color_eng_100.plt
 USER: SPEREIRA
 DATE: 6/10/2021
 TIME: 2:16:13 PM
 FILE: \

8/23/99

290 280 270 260 250 240 230 220 210 200 190 180 170 160 150 140 130 120 110 100 90 80 70 60 50 40 30 20 10 0 10

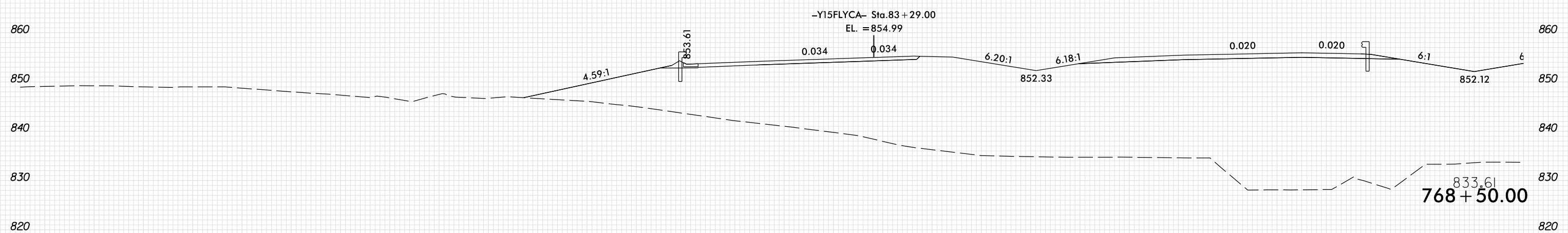
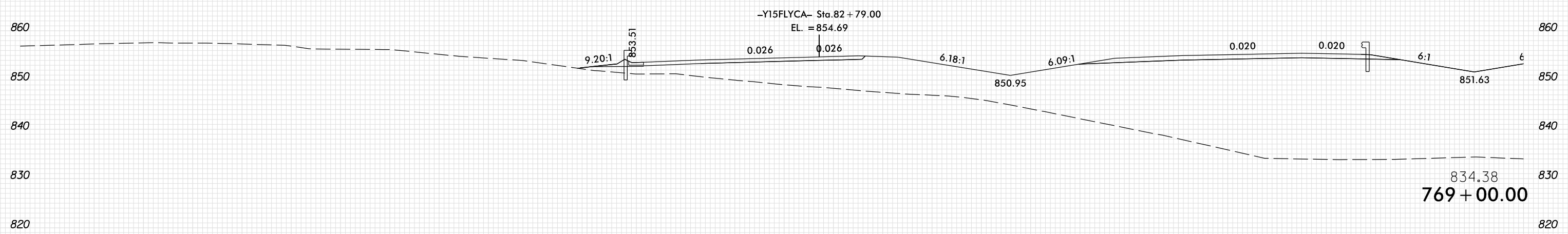
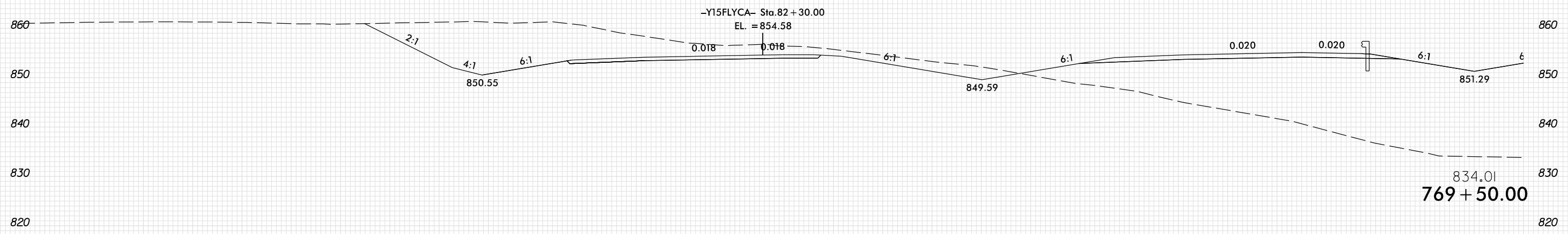

290 280 270 260 250 240 230 220 210 200 190 180 170 160 150 140 130 120 110 100 90 80 70 60 50 40 30 20 10 0 10

PLOT DRIVER: NCD01.pdf_color_eng_100.plt
 USER: SPEREIRA
 DATE: 6/10/2021
 TIME: 2:16:13 PM
 FILE: \

8/23/99

	PROJ. REFERENCE NO.	SHEET NO.
	U-2579AB	X-46

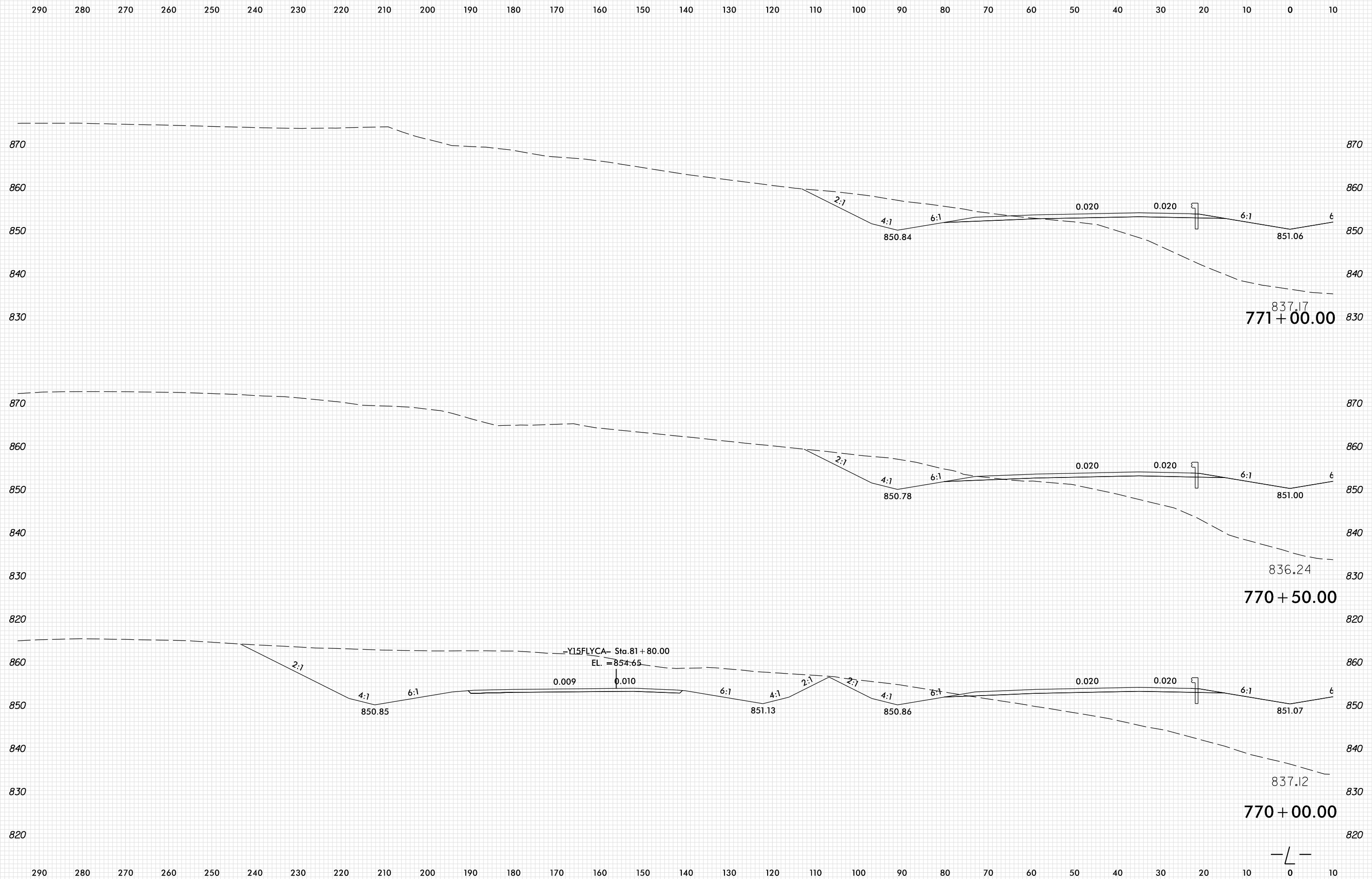

PLOT DRIVER: NCD01_pdf_color_eng_100.plt
 USER: SPEREIRA
 DATE: 6/10/2021
 TIME: 2:16:14 PM
 FILE: \

8/23/99

0 5 10	PROJ. REFERENCE NO.	SHEET NO.
	U-2579AB	X-47

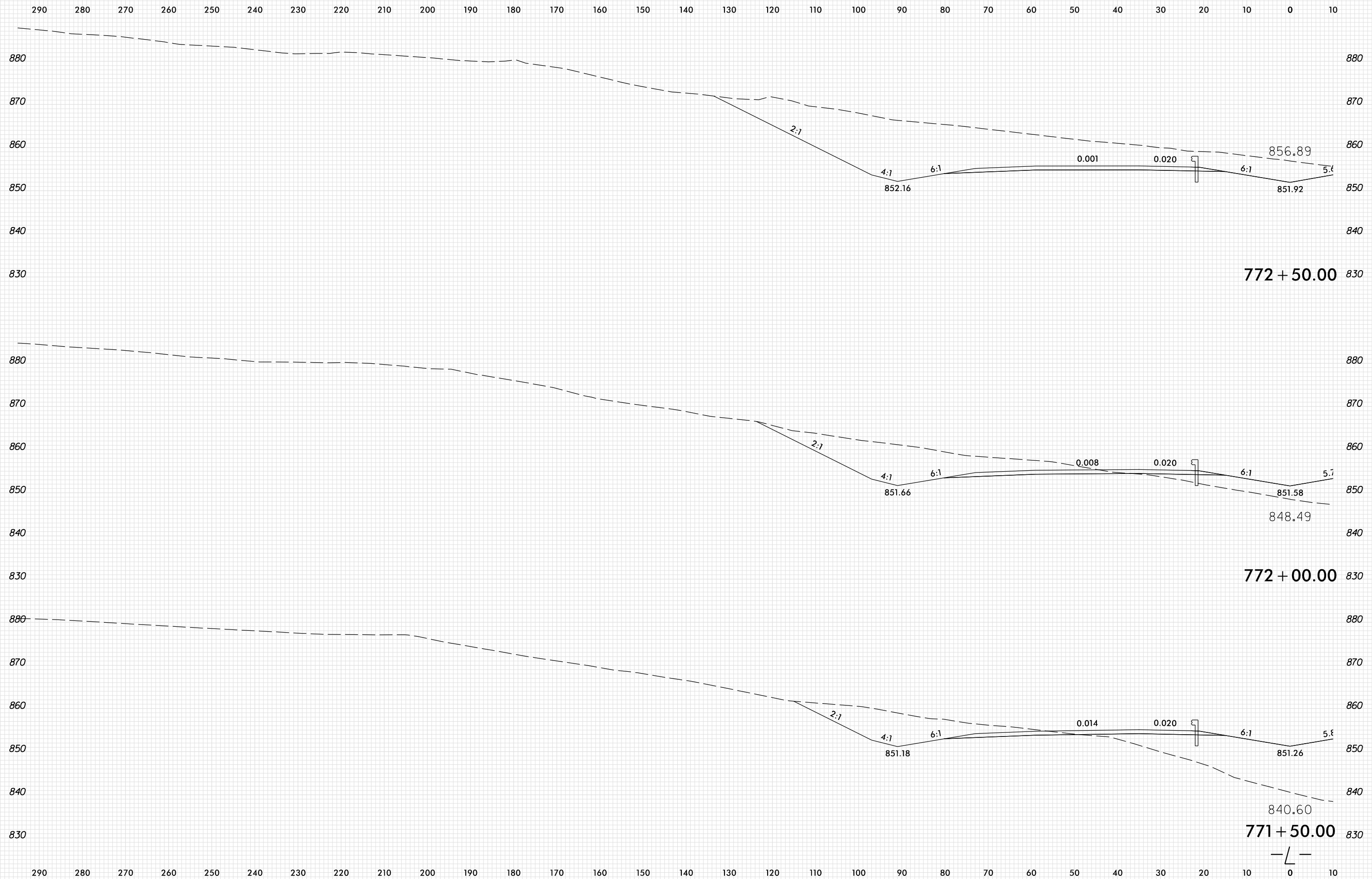

PLOT DRIVER: NCDOT_pdf_color_eng_100.plt
 USER: SPEREIRA
 DATE: 6/10/2021
 TIME: 2:16:15 PM
 FILE: \

8/23/99

0 5 10	PROJ. REFERENCE NO.	SHEET NO.
	U-2579AB	X-48

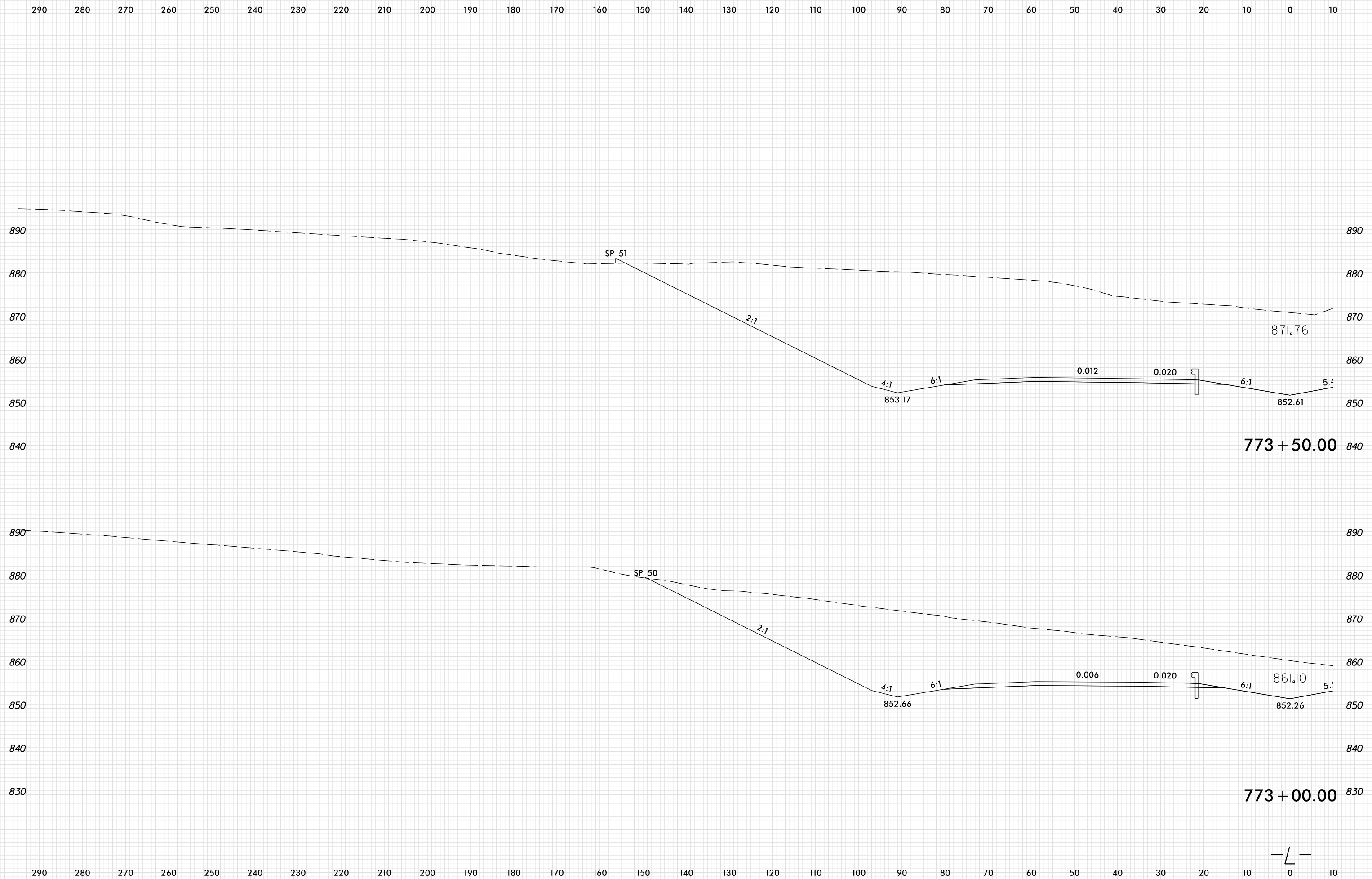

PLOT DRIVER: NCDOT_pdf_color_eng_100.plt
 USER: SPEREIRA
 DATE: 6/10/2021
 TIME: 2:16:15 PM
 FILE: \

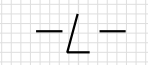

8/23/99

0 5 10	PROJ. REFERENCE NO.	SHEET NO.
	U-2579AB	X-49

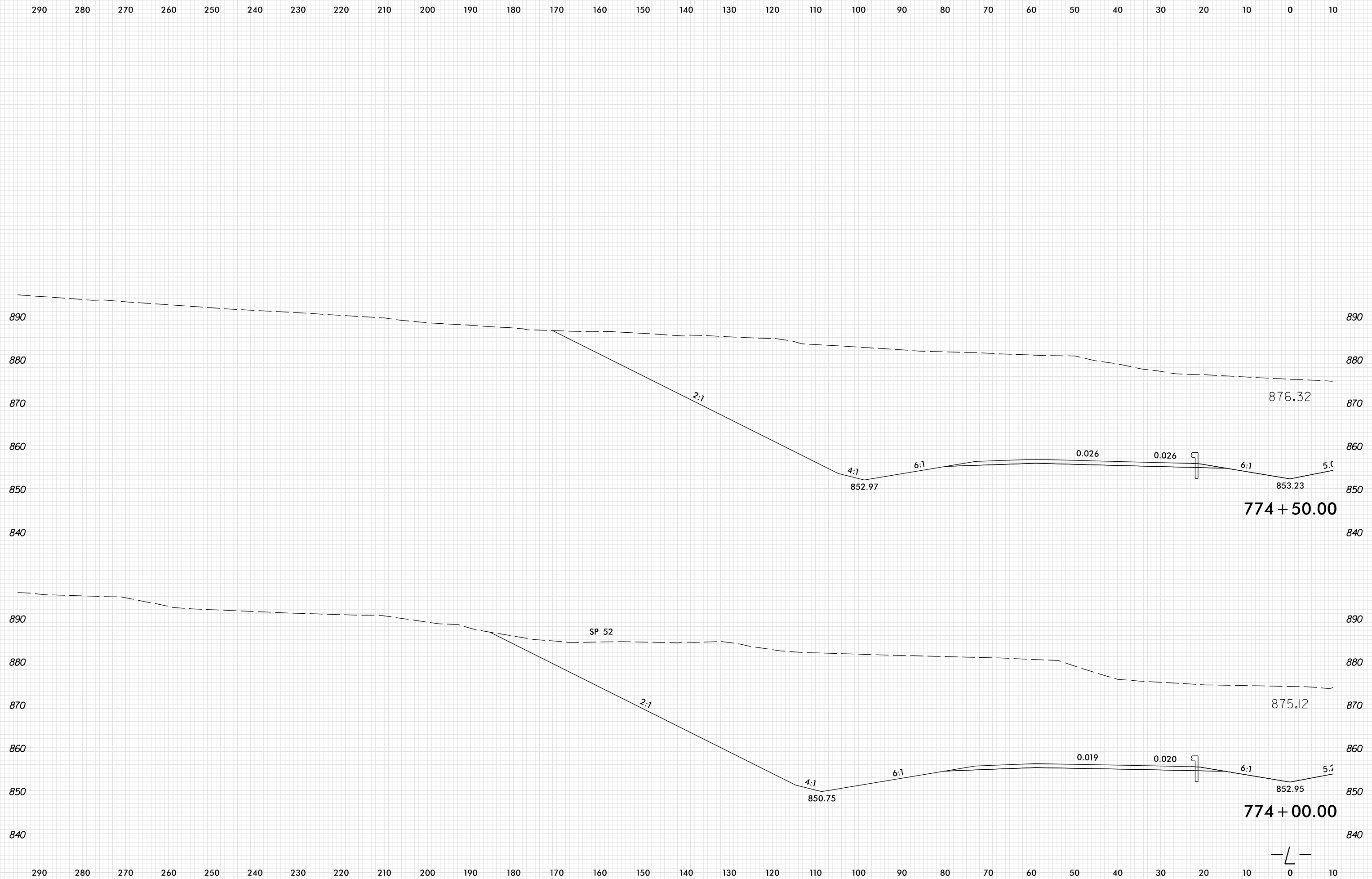

PLOT DRIVER: NCDOT_pdf_color_eng_100.plt
 USER: SPEREIRA
 DATE: 6/10/2021
 TIME: 2:16:16 PM
 FILE: \

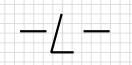

8/23/99

0 5 10	PROJ. REFERENCE NO.	SHEET NO.
	U-2579AB	X-50

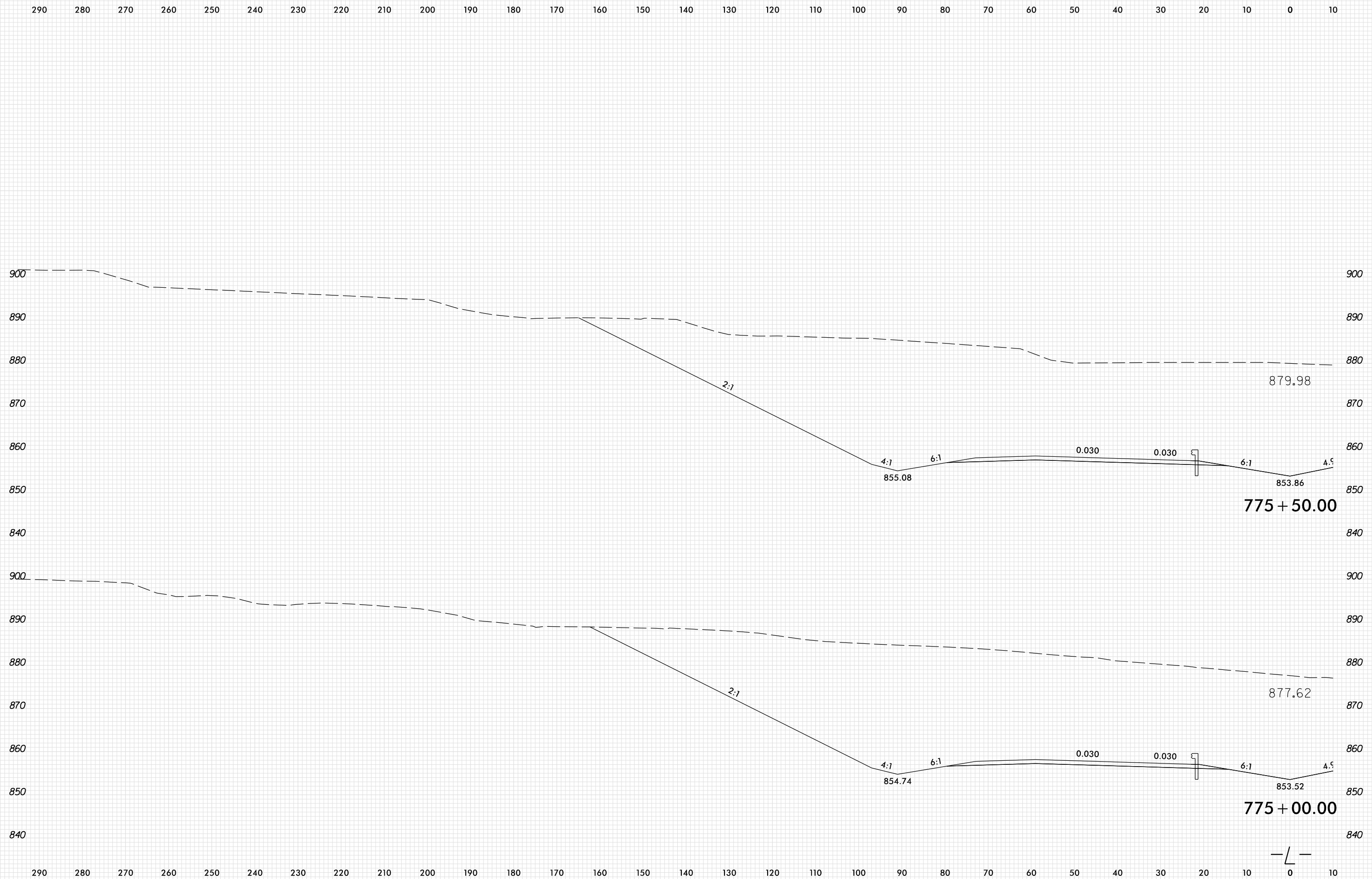

PLOT DRIVER: NCDOT_pdf_color_eng_100.plt
 USER: SPEREIRA
 DATE: 6/10/2021
 TIME: 2:16:16 PM
 FILE: \

8/23/99

	PROJ. REFERENCE NO.	SHEET NO.
	U-2579AB	X-51

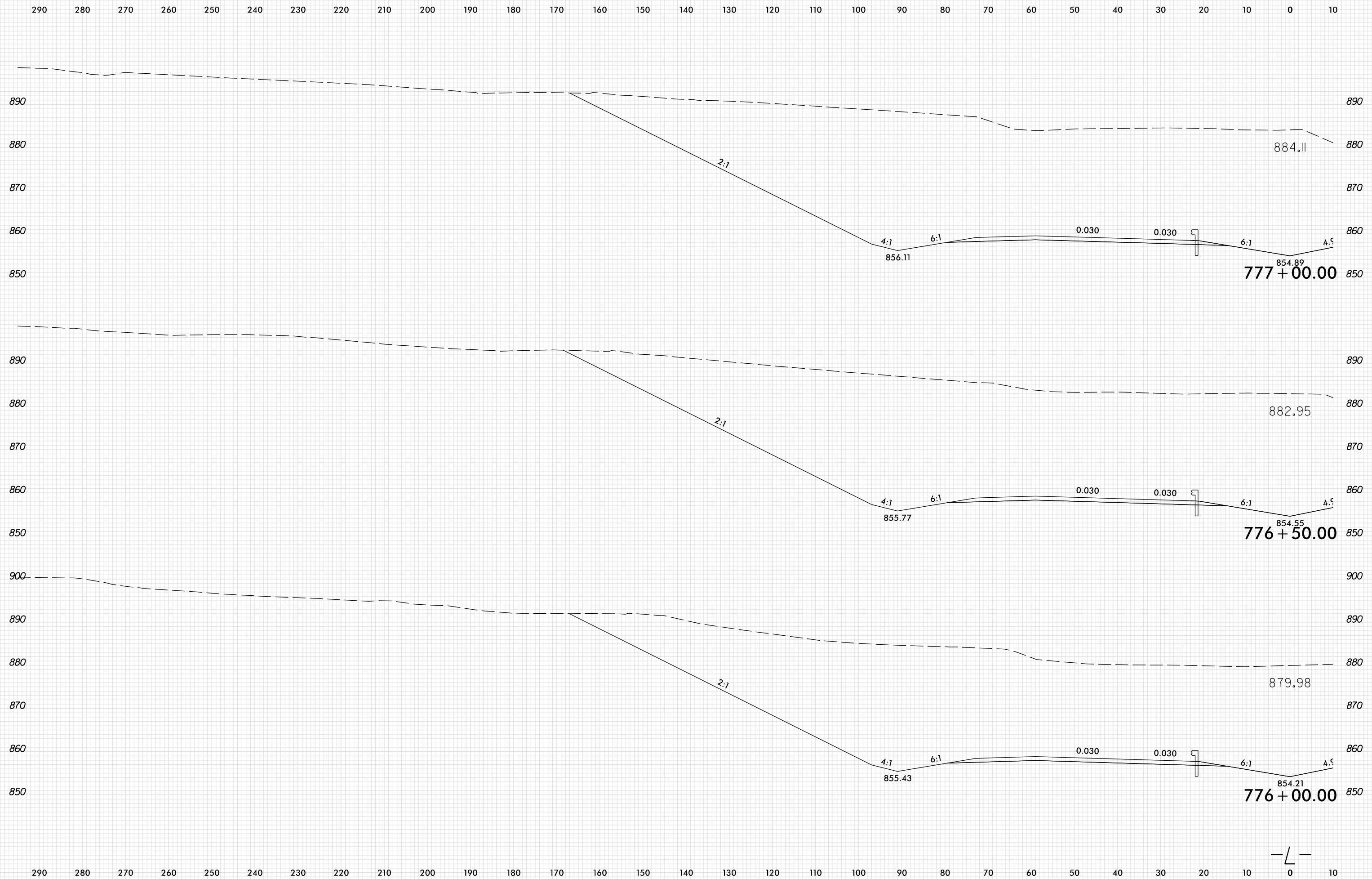

PLOT DRIVER: NCDOT_pdf_color_eng_100.plt
 USER: SPEREIRA
 DATE: 6/10/2021
 TIME: 2:16:17 PM
 FILE: \

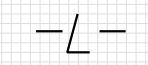

8/23/99

0 5 10	PROJ. REFERENCE NO.	SHEET NO.
	U-2579AB	X-52

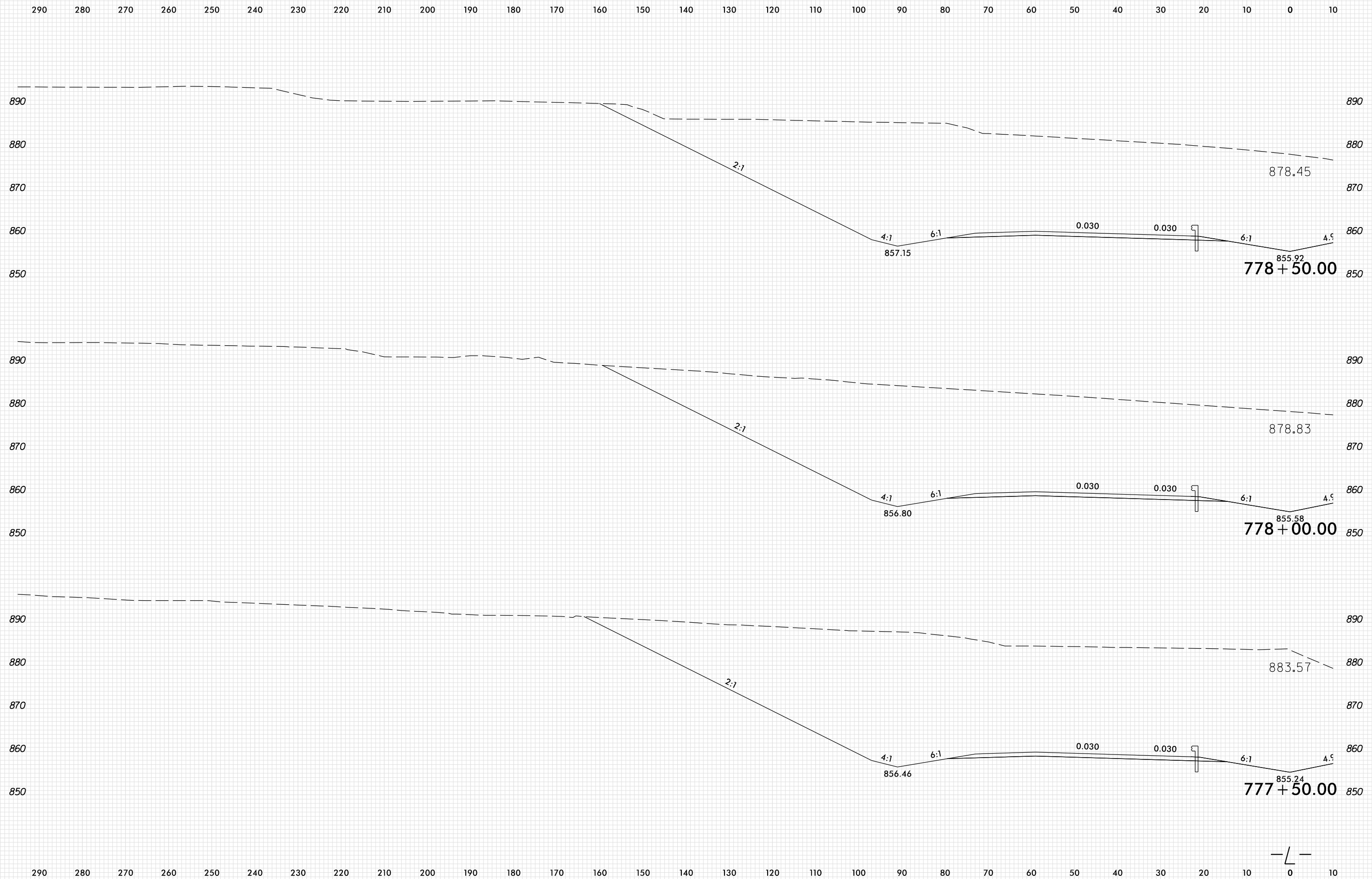

PLOT DRIVER: NCDOT_pdf_color_eng_100.plt
 USER: SPEREIRA
 DATE: 6/10/2021
 TIME: 2:16:18 PM
 FILE: \

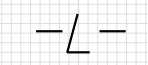

8/23/99

0 5 10	PROJ. REFERENCE NO.	SHEET NO.
	U-2579AB	X-53

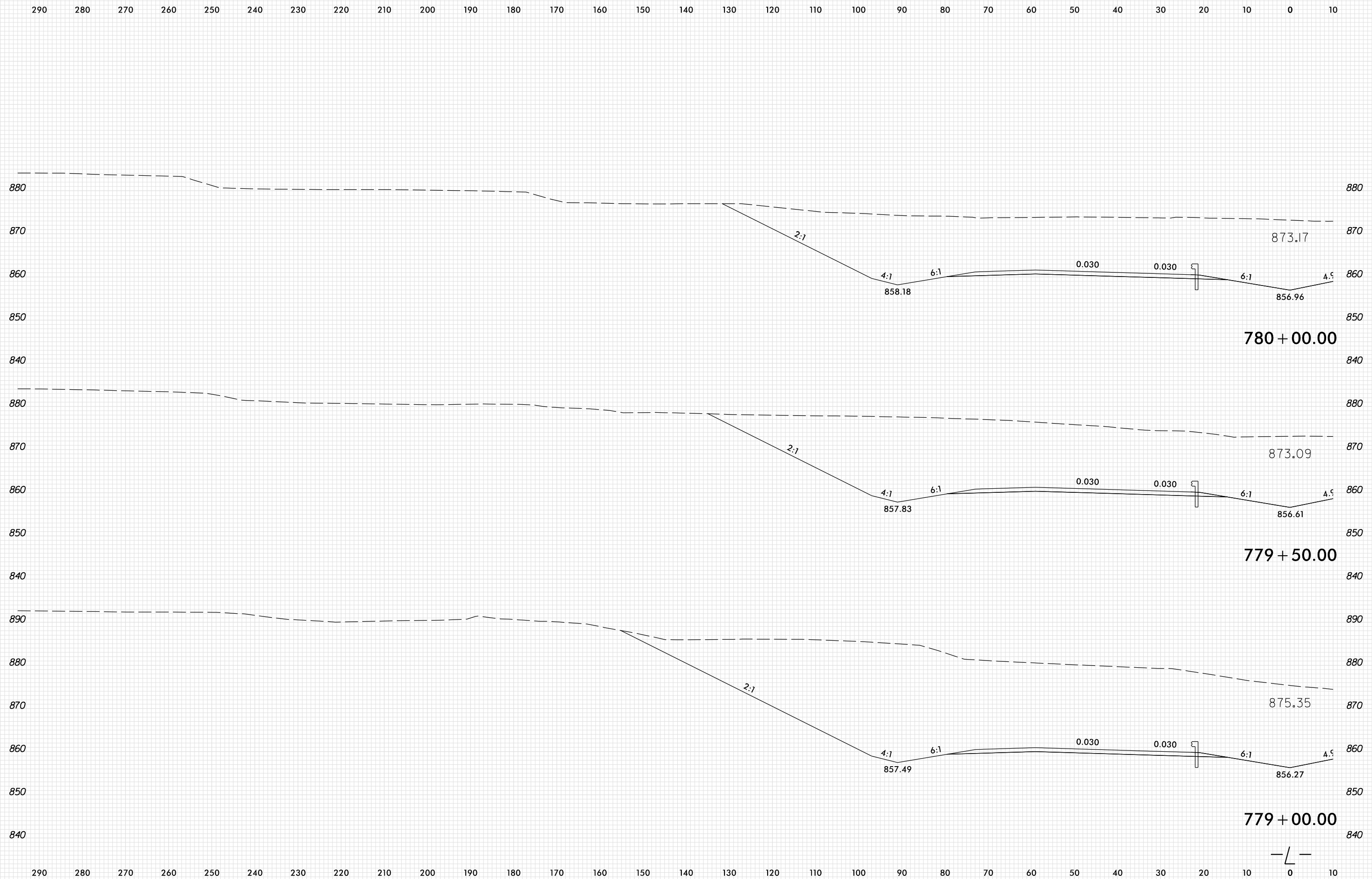

PLOT DRIVER: NCDOT_pdf_color_eng_100.plt
 USER: SPEREIRA
 DATE: 6/10/2021
 TIME: 2:16:18 PM
 FILE: \

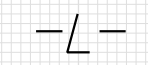

8/23/99

0 5 10	PROJ. REFERENCE NO.	SHEET NO.
	U-2579AB	X-54

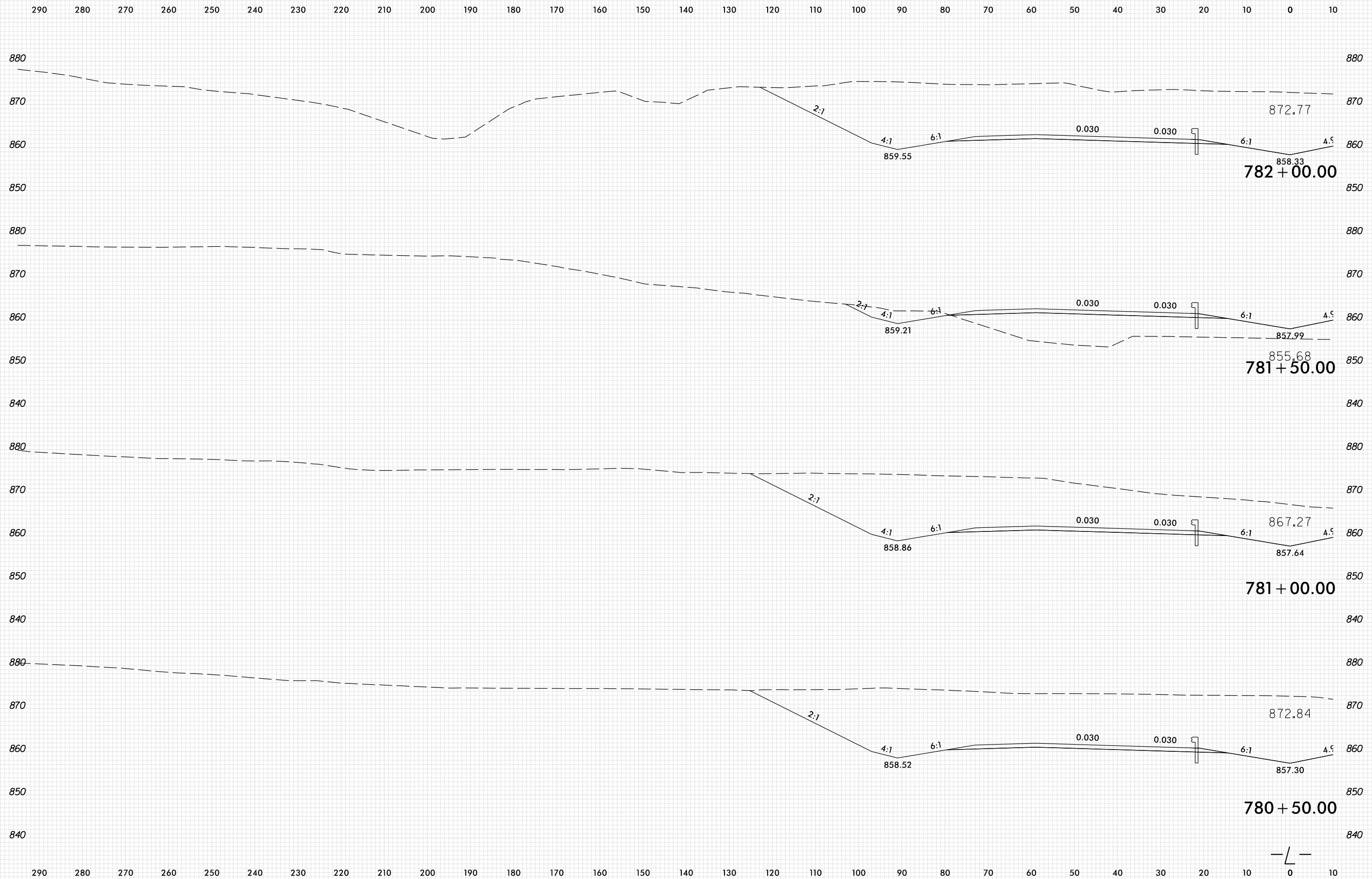

PLOT DRIVER: NCDOT_pdf_color_eng_100.plt
 USER: SPEREIRA
 DATE: 6/10/2021
 TIME: 2:16:19 PM
 FILE: \

8/23/99

0 5 10	PROJ. REFERENCE NO.	SHEET NO.
	U-2579AB	X-55

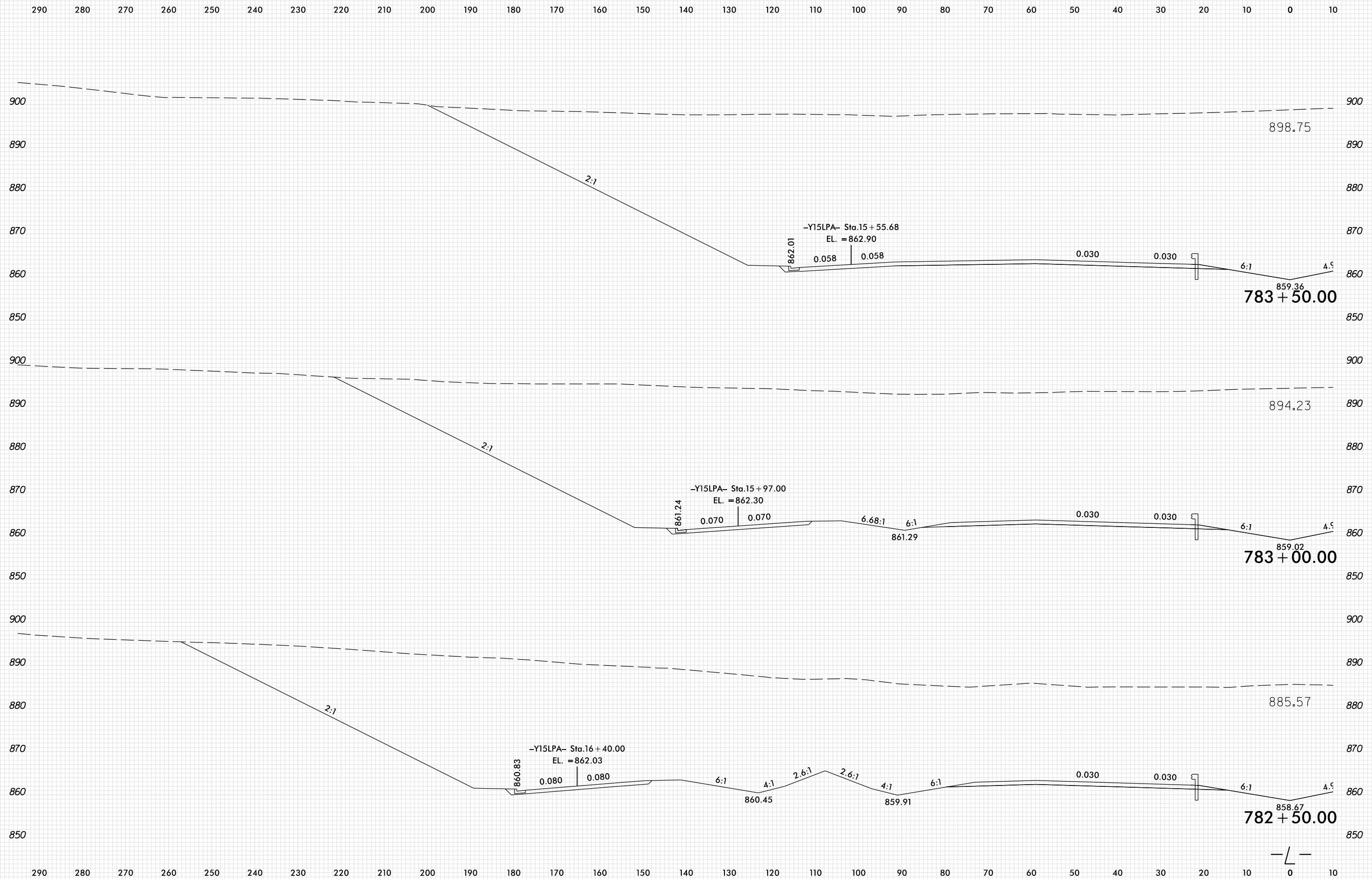

PLOT DRIVER: NCD01_pdf_color_eng_100.plt
 USER: SPEREIRA
 DATE: 6/10/2021
 TIME: 2:16:20 PM
 FILE: \

8/23/99

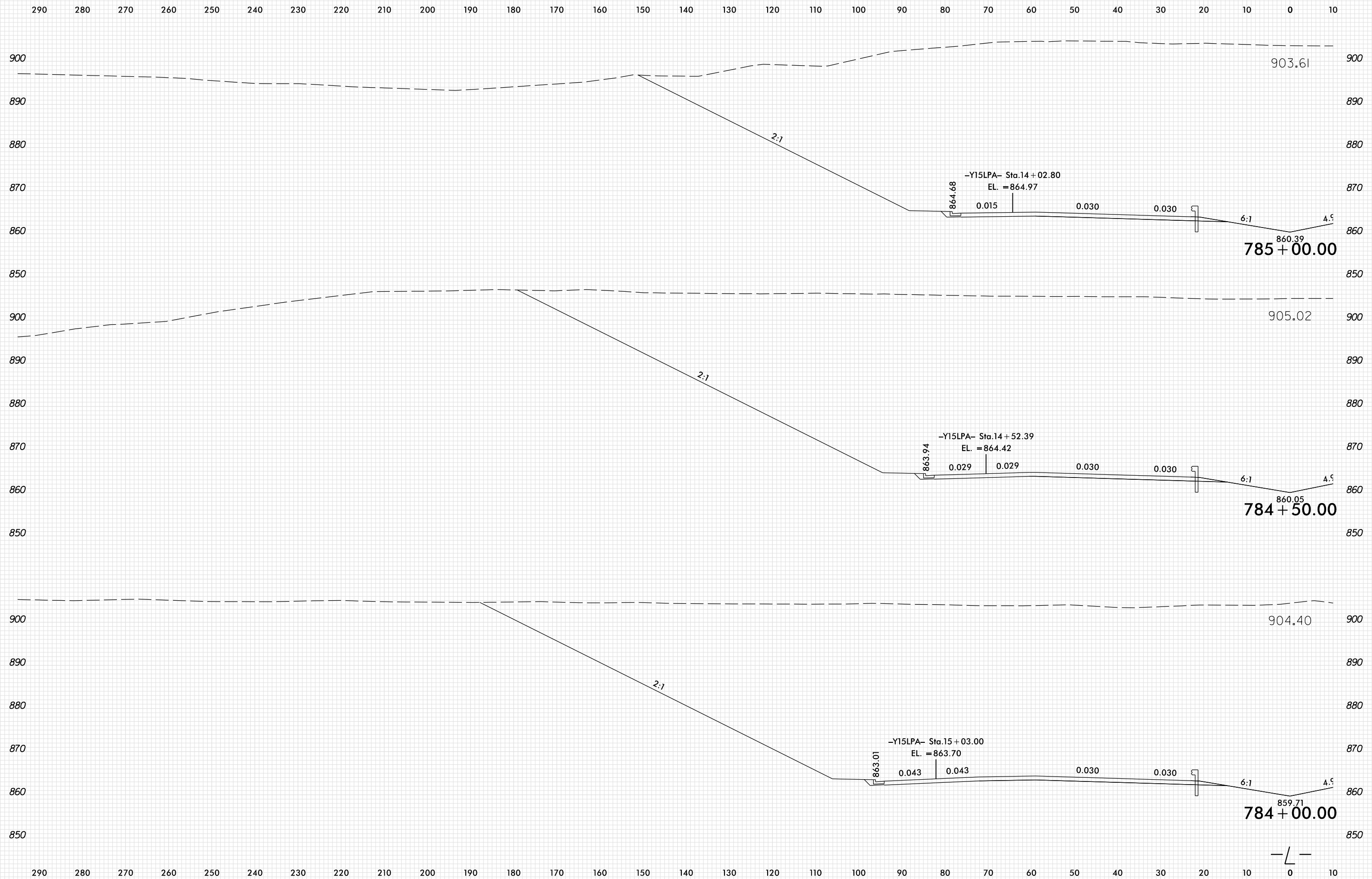

PLOT DRIVER: NCD01_pdf_color_eng_100.plt
 USER: SPEREIRA
 DATE: 6/10/2021
 TIME: 2:16:22 PM
 FILE: \

8/23/99

0 5 10	PROJ. REFERENCE NO.	SHEET NO.
	U-2579AB	X-57

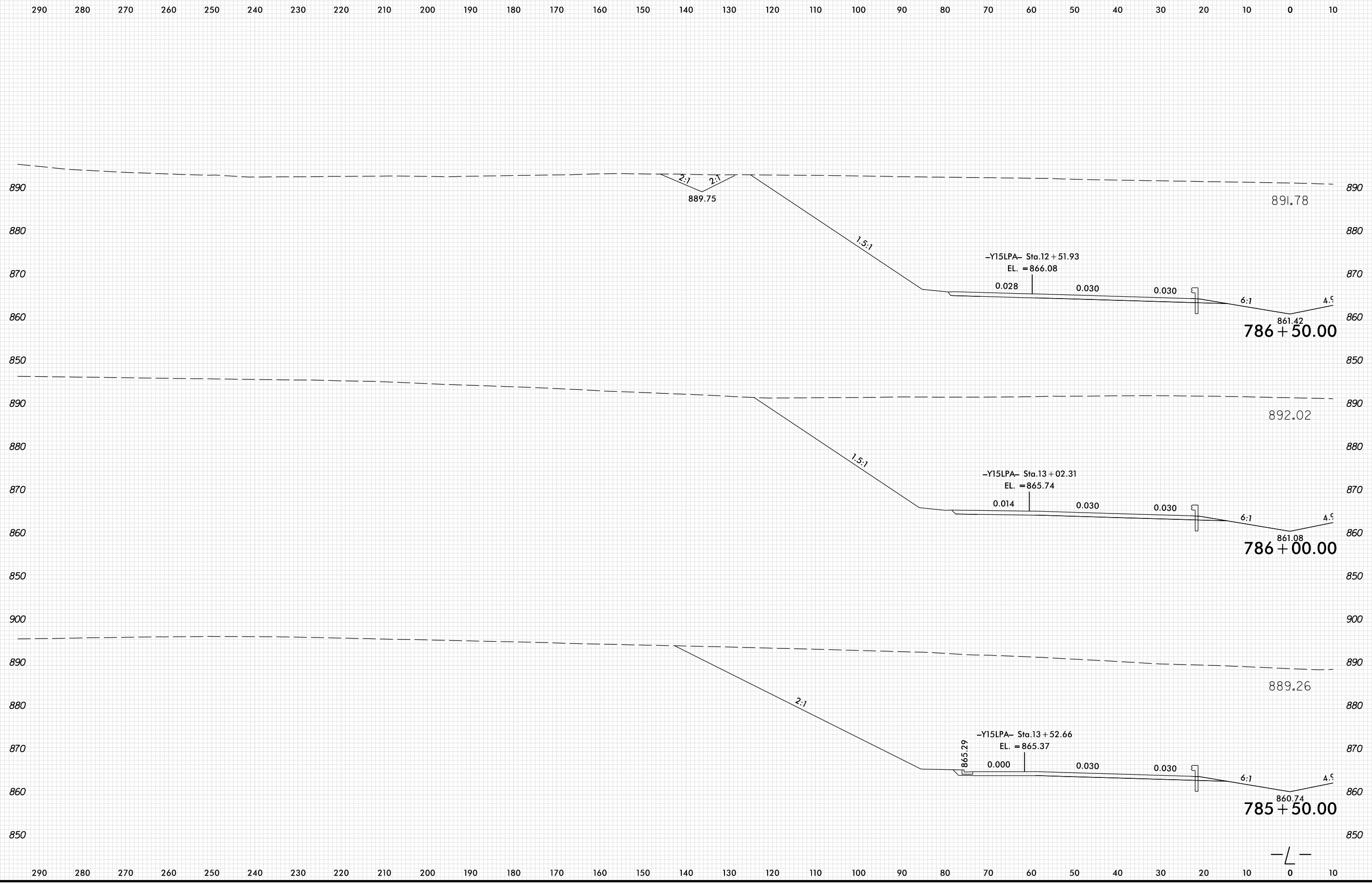

PLOT DRIVER: NCDOT_pdf_color_eng_100.plt
 USER: SPEREIRA
 DATE: 6/10/2021
 TIME: 2:16:22 PM
 FILE: \

8/23/99

0 5 10	PROJ. REFERENCE NO.	SHEET NO.
	U-2579AB	X-58

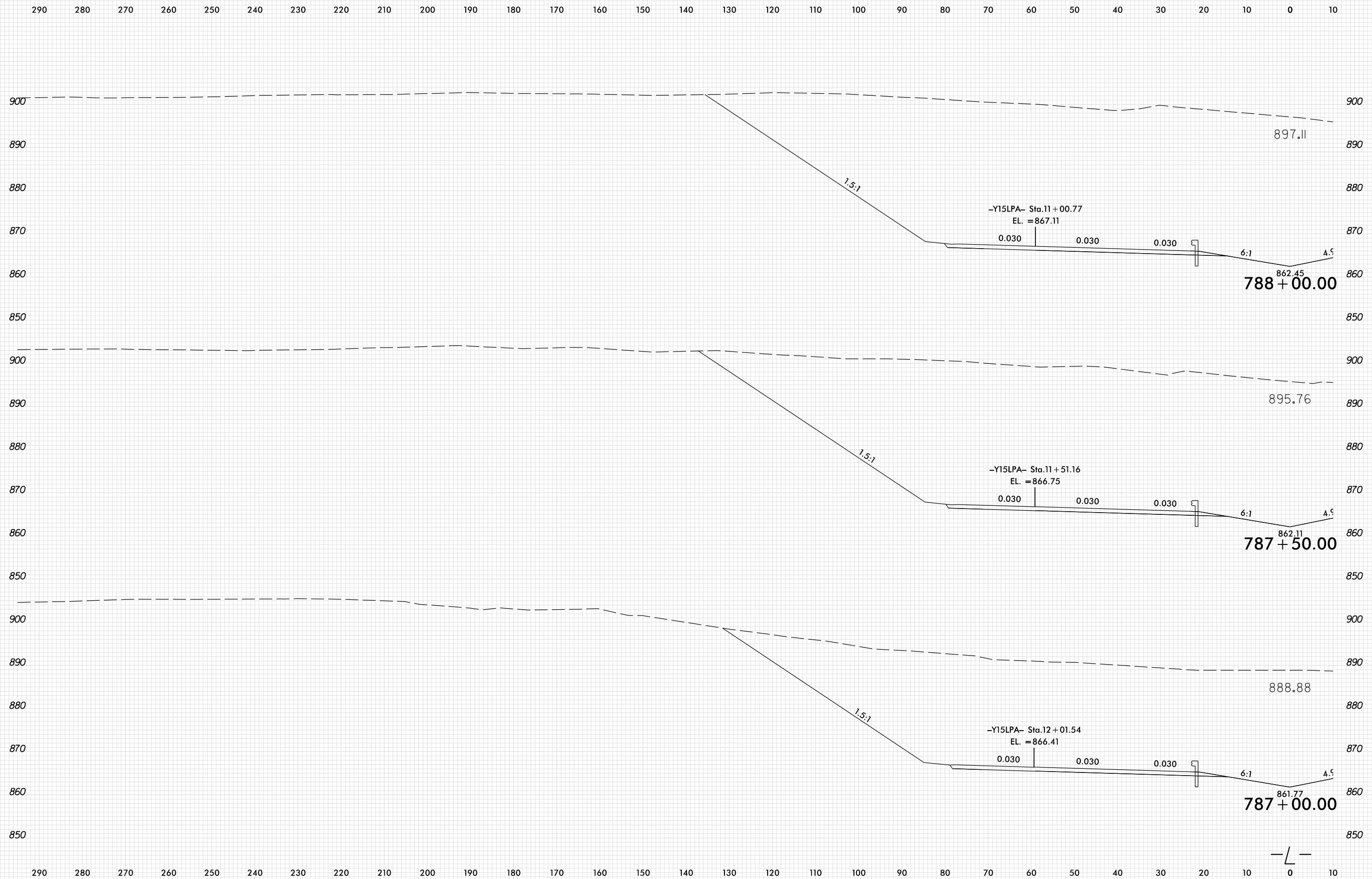

PLOT DRIVER: NCDOT_pdf_color_eng_100.plt
 USER: SPEREIRA
 DATE: 6/10/2021
 TIME: 2:16:23 PM
 FILE: \

8/23/99



PROJ. REFERENCE NO.	SHEET NO.
U-2579AB	X-59

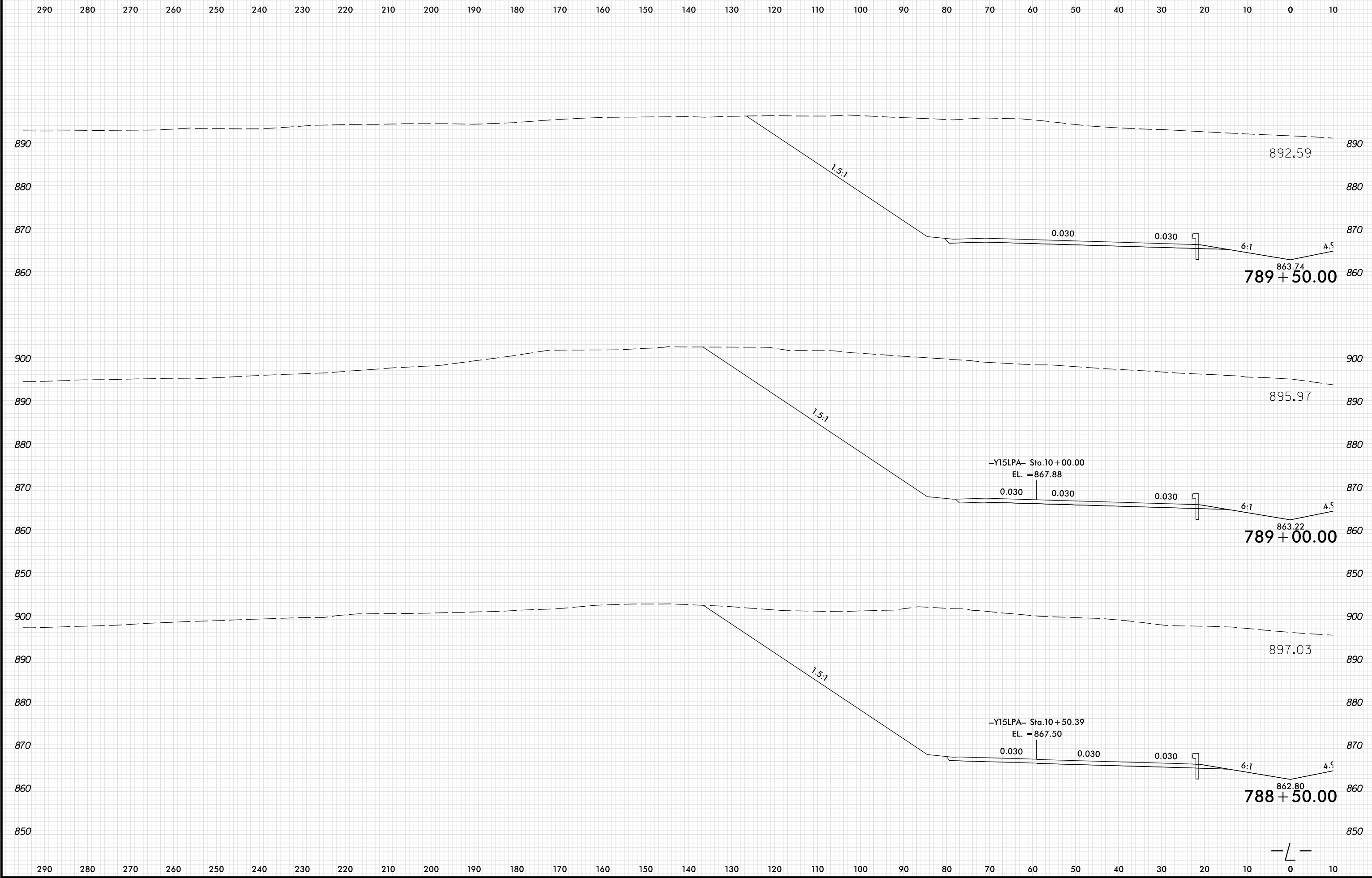

PLOT DRIVER: NCDOT_pdf_color_eng_100.plt
 USER: SPEREIRA
 DATE: 6/10/2021
 TIME: 2:16:23 PM
 FILE: \

8/23/99

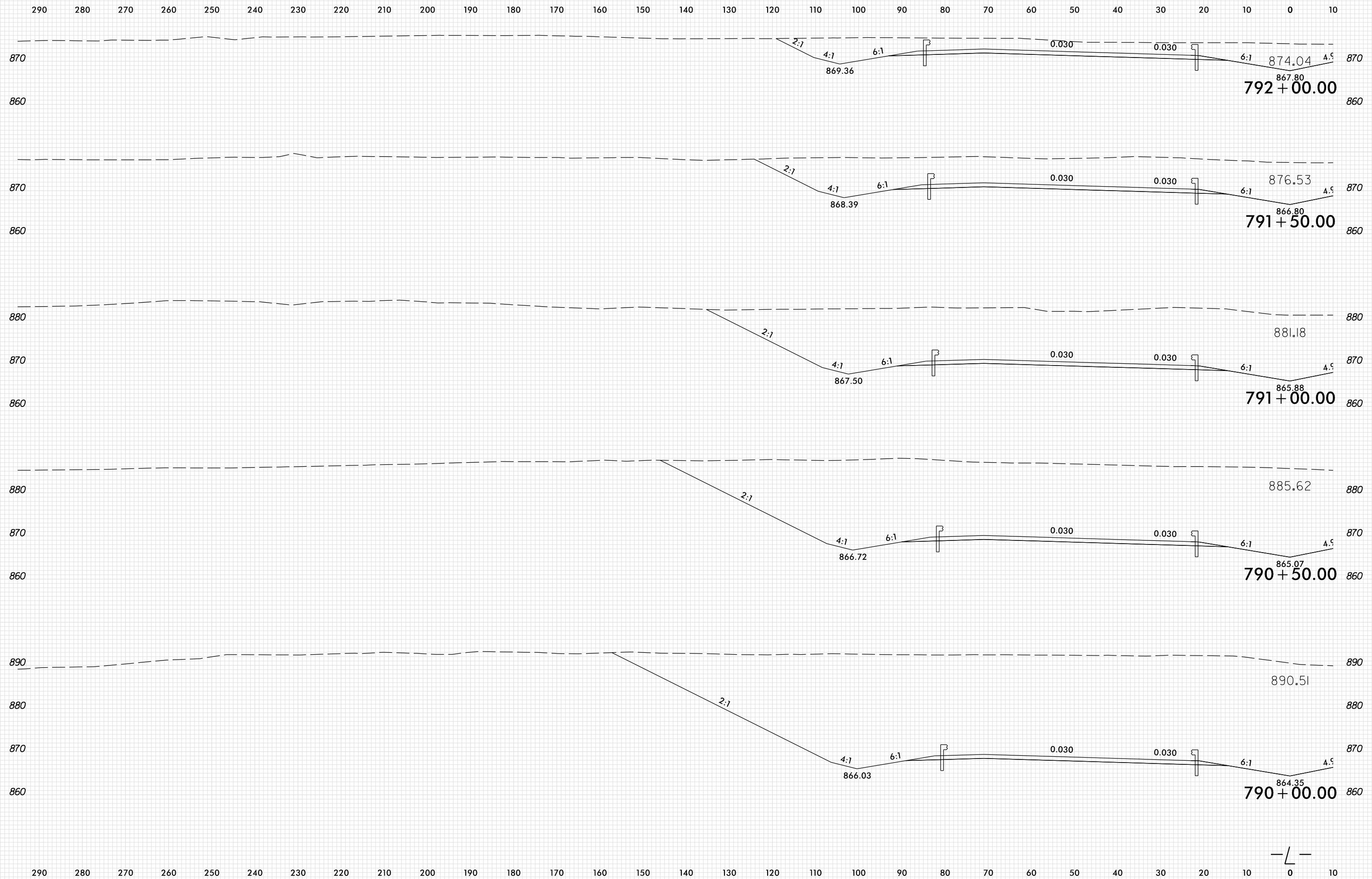

PLOT DRIVER: NCDOT_pdf_color_eng_100.plt
 USER: SPEREIRA
 DATE: 6/10/2021
 TIME: 2:16:24 PM
 FILE: \

—L—

8/23/99

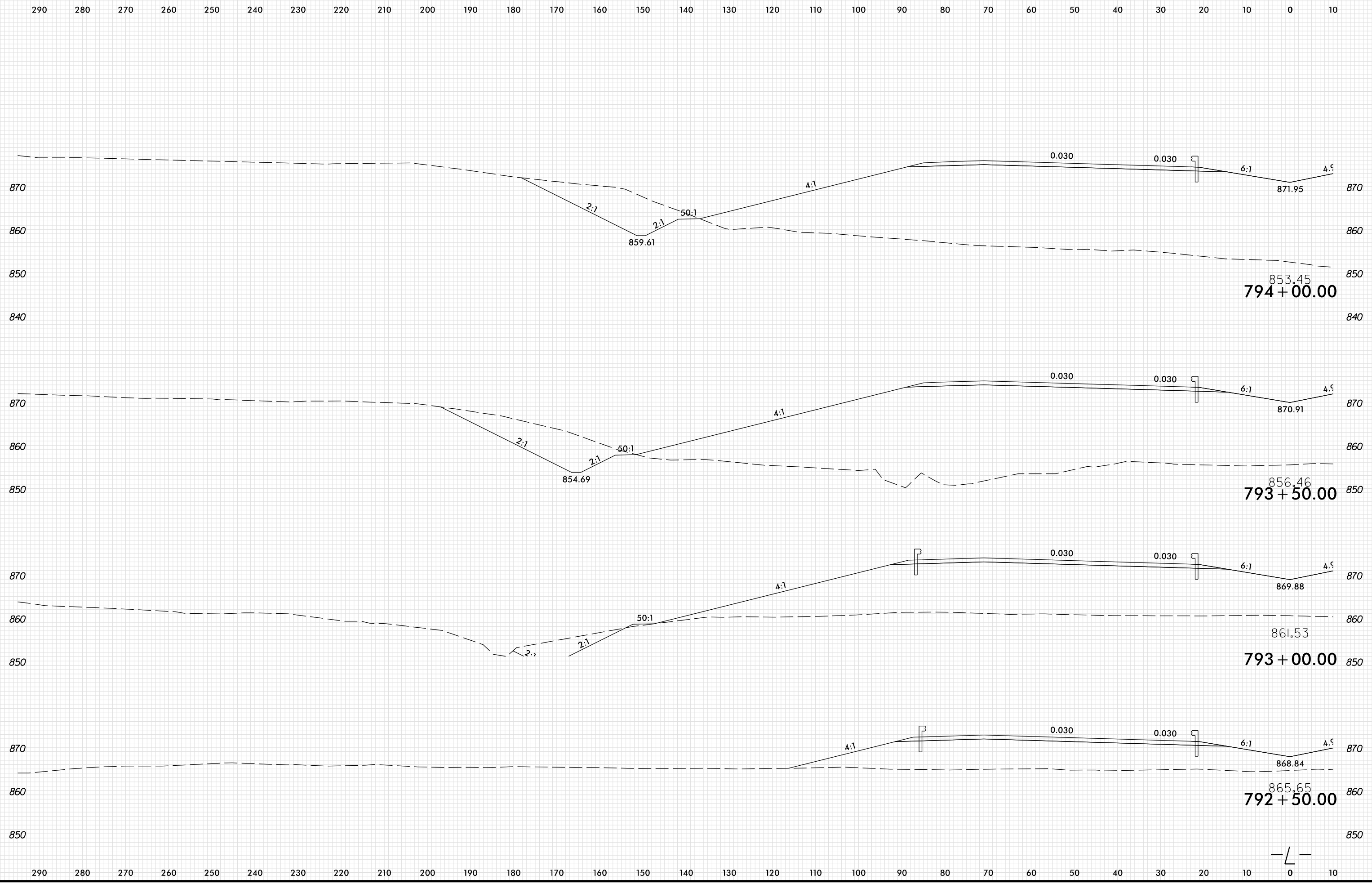

PLOT DRIVER: NCD01_pdf_color_eng_100.plt
 USER: SPEREIRA
 DATE: 6/10/2021
 TIME: 2:16:25 PM
 FILE: \

8/23/99

0 5 10	PROJ. REFERENCE NO.	SHEET NO.
	U-2579AB	X-62

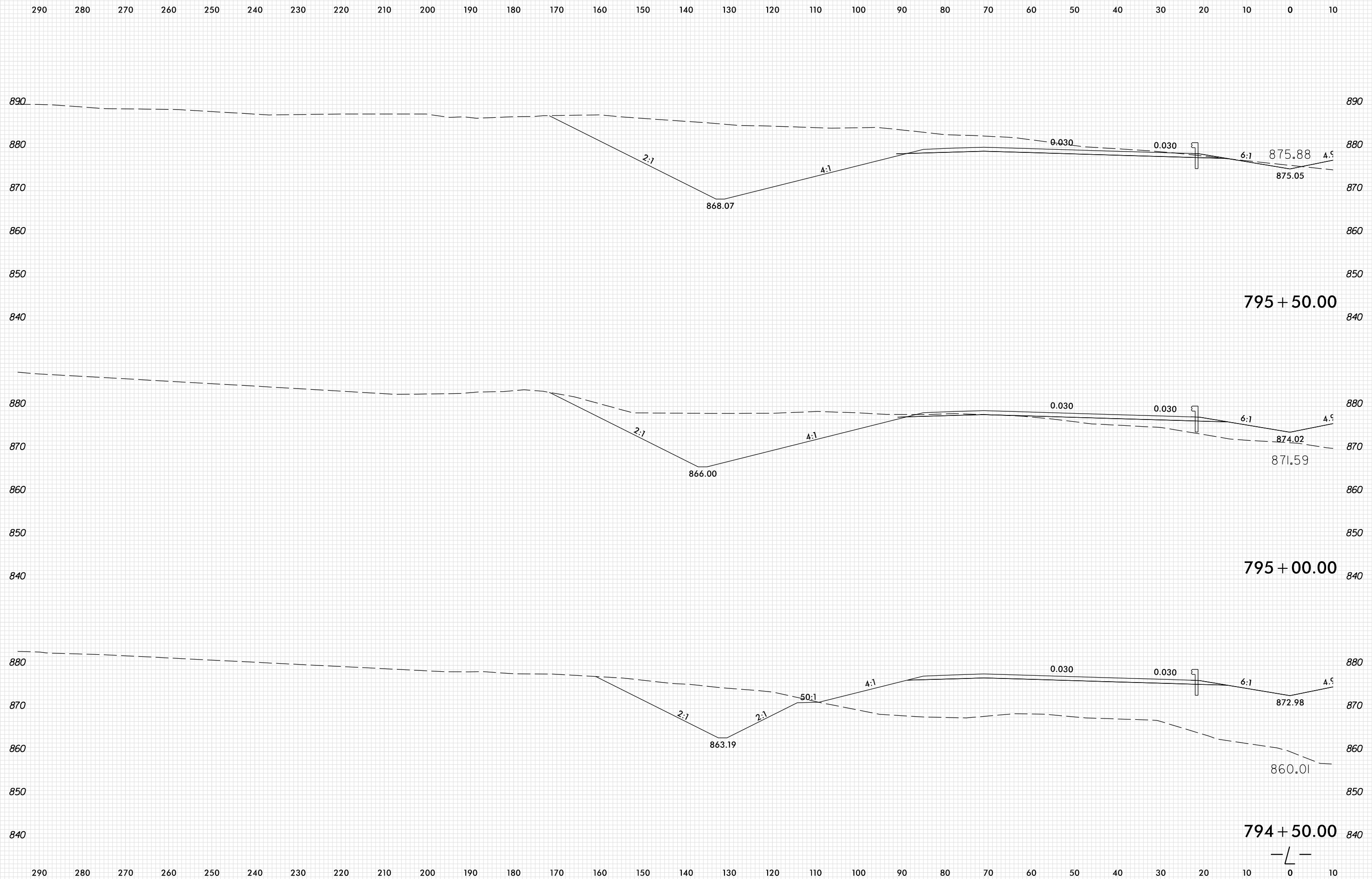

PLOT DRIVER: NCDOT_pdf_color_eng_100.plt
 USER: SPEREIRA
 DATE: 6/10/2021
 TIME: 2:16:25 PM
 FILE: \

8/23/99

	PROJ. REFERENCE NO.	SHEET NO.
	U-2579AB	X-63

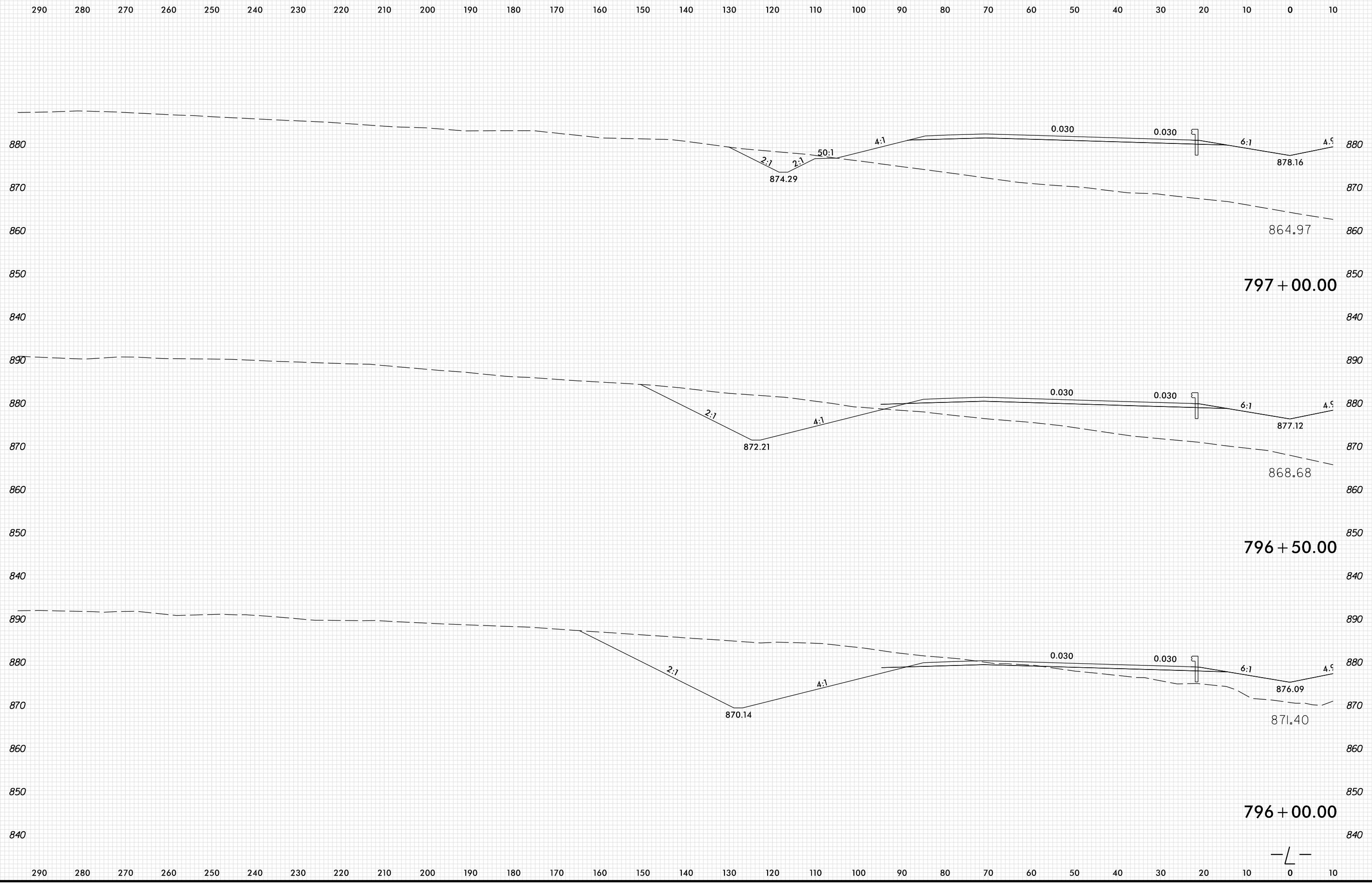

PLOT DRIVER: NCDOT_pdf_color_eng_100.plt
 USER: SPEREIRA
 DATE: 6/10/2021
 TIME: 2:16:26 PM
 FILE: \

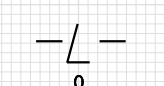

8/23/99

0 5 10	PROJ. REFERENCE NO.	SHEET NO.
	U-2579AB	X-64

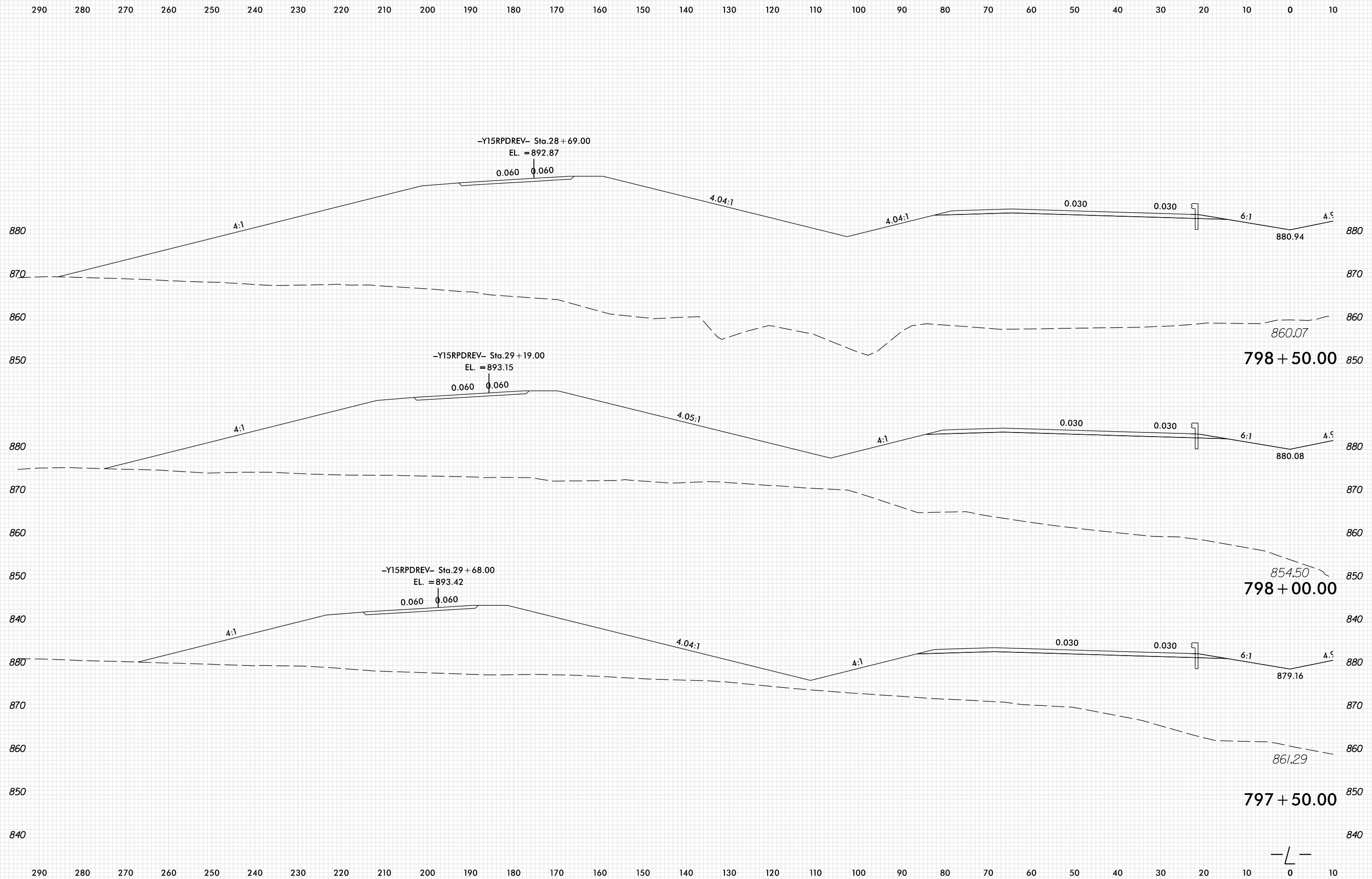

PLOT DRIVER: NCDOT_pdf_color_eng_100.plt
 USER: SPEREIRA
 DATE: 6/10/2021
 TIME: 2:16:26 PM
 FILE: \

8/23/99

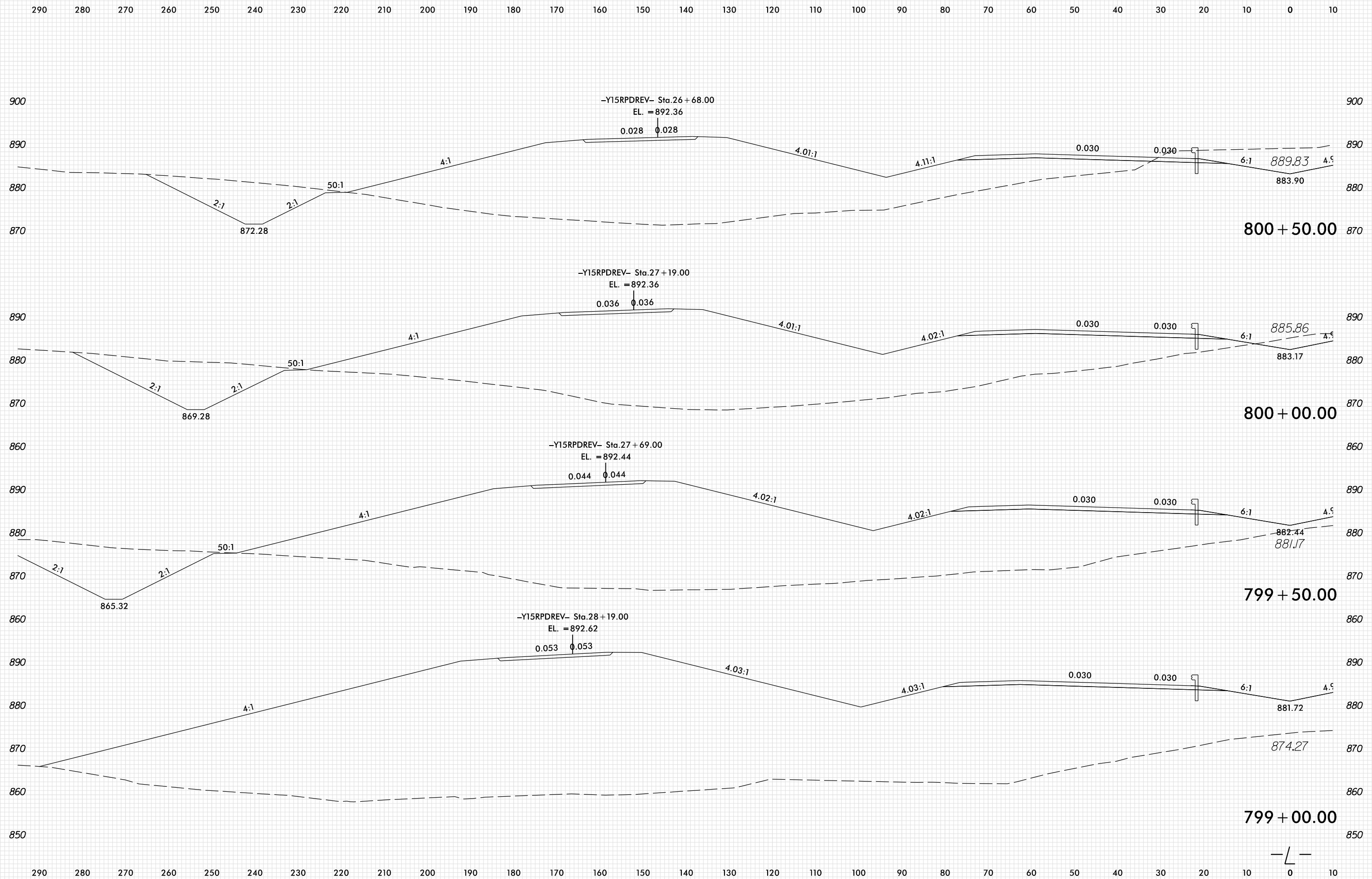

PLOT DRIVER: NCD01_pdf_color_eng_100.plt
 USER: SPEREIRA
 DATE: 6/10/2021
 TIME: 2:16:27 PM
 FILE: \

8/23/99

0 5 10	PROJ. REFERENCE NO.	SHEET NO.
	U-2579AB	X-66

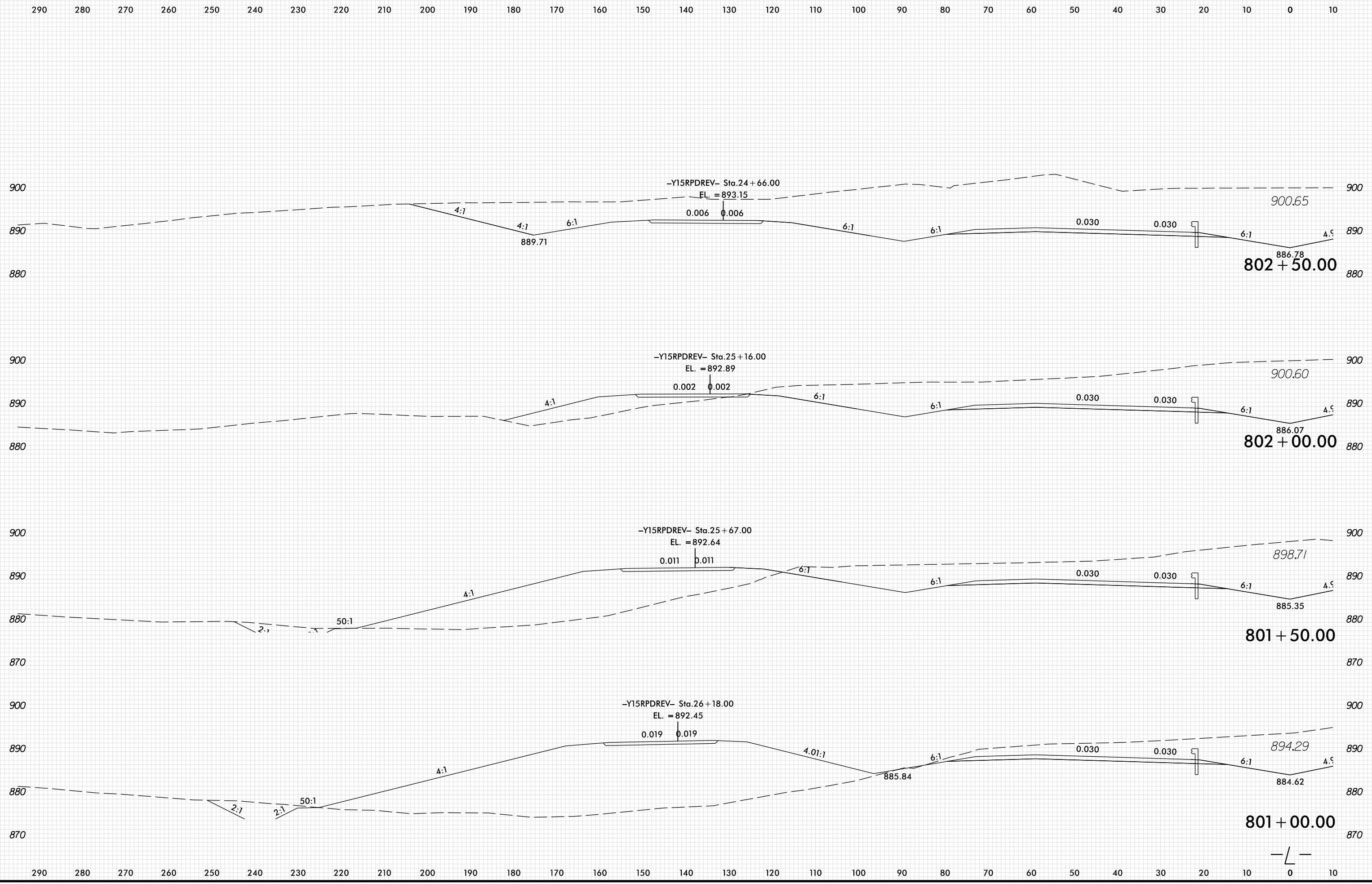

PLOT DRIVER: NCD01_pdf_color_eng_100.plt
 USER: SPEREIRA
 DATE: 6/10/2021
 TIME: 2:16:28 PM
 FILE: \

8/23/99

290 280 270 260 250 240 230 220 210 200 190 180 170 160 150 140 130 120 110 100 90 80 70 60 50 40 30 20 10 0 10

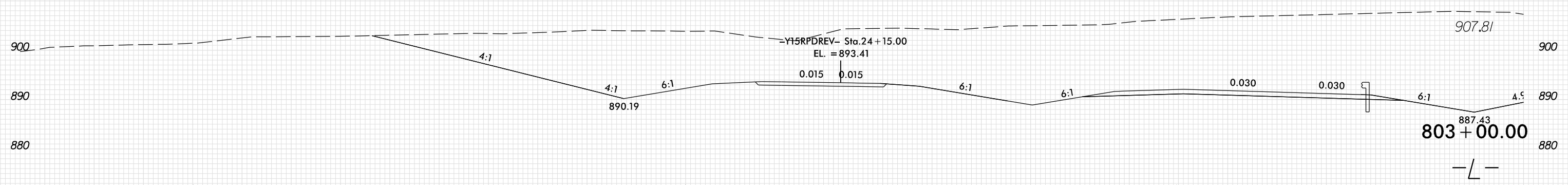
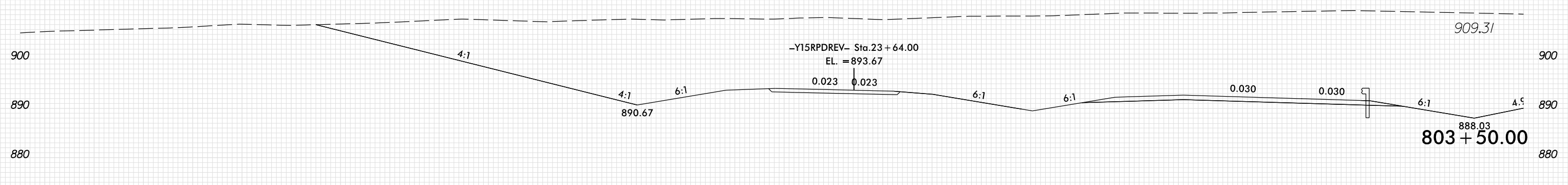
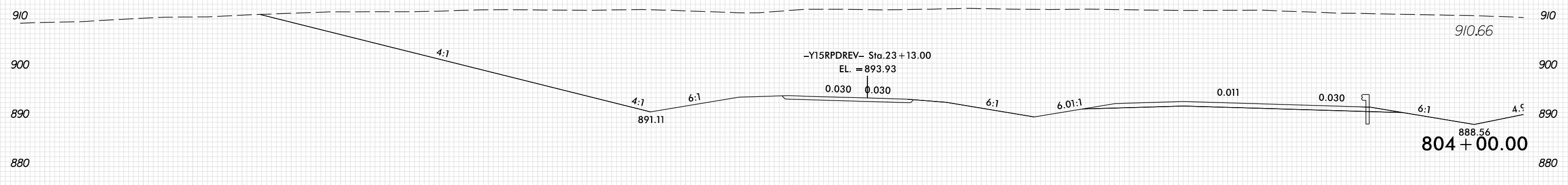
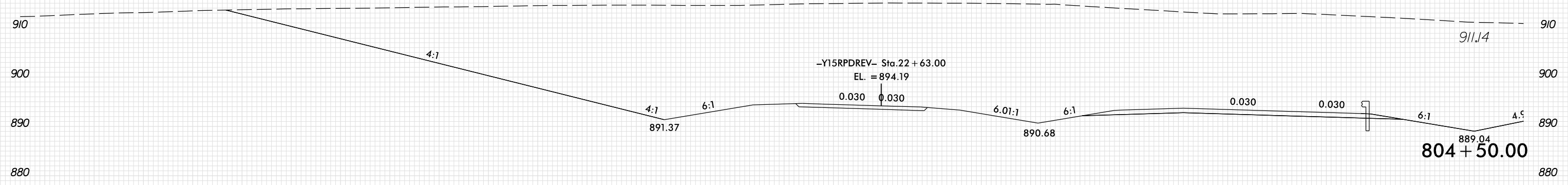

290 280 270 260 250 240 230 220 210 200 190 180 170 160 150 140 130 120 110 100 90 80 70 60 50 40 30 20 10 0 10

PLOT DRIVER: NCDOT_pdf_color_eng_100.plt
USER: SPEREIRA
DATE: 6/10/2021
TIME: 2:16:28 PM
FILE: \

8/23/99

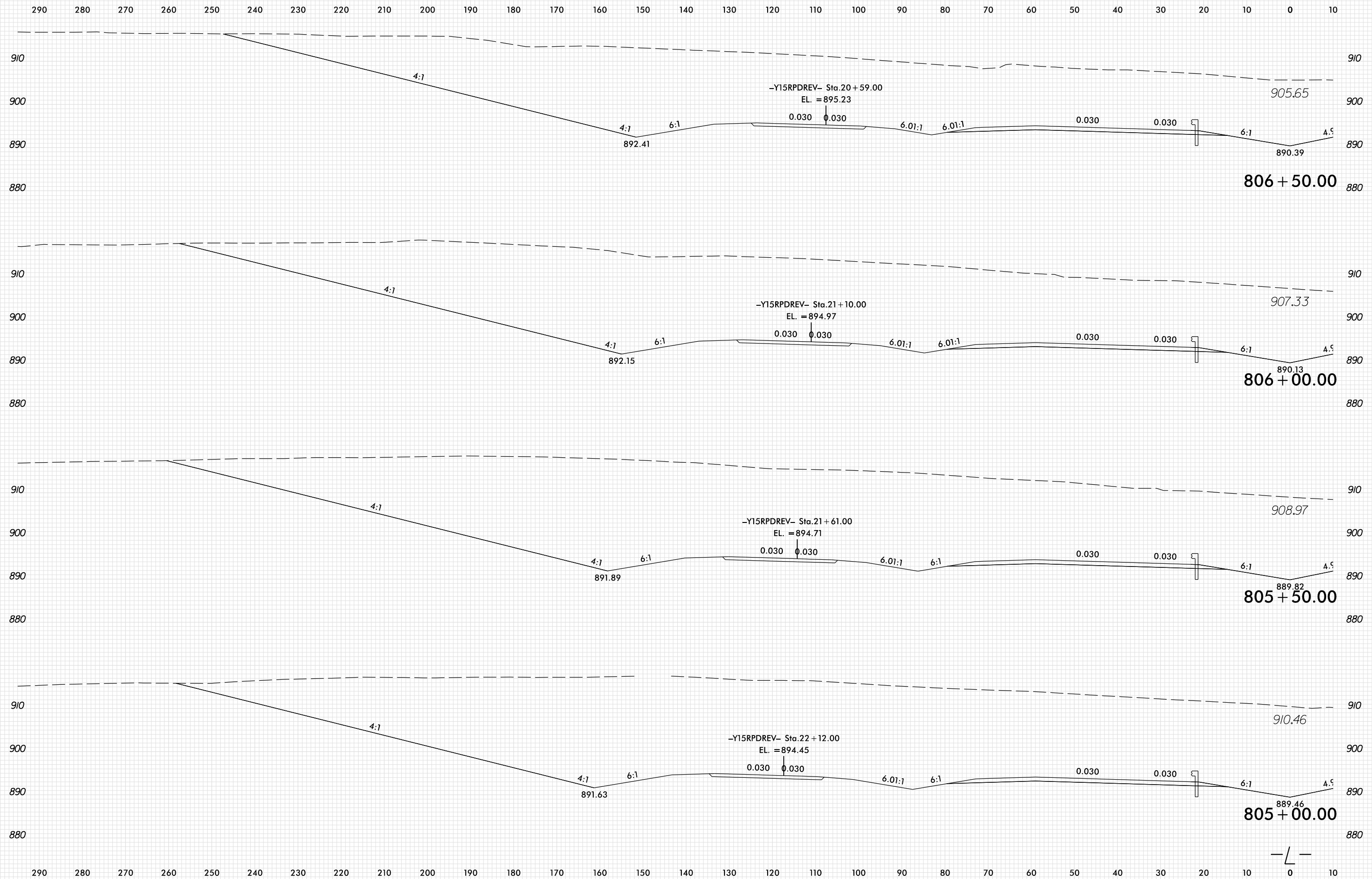

PLOT DRIVER: NCD01_pdf_color_eng_100.plt
 USER: SPEREIRA
 DATE: 6/10/2021
 TIME: 2:16:29 PM
 FILE: \

8/23/99

0 5 10	PROJ. REFERENCE NO.	SHEET NO.
	U-2579AB	X-69

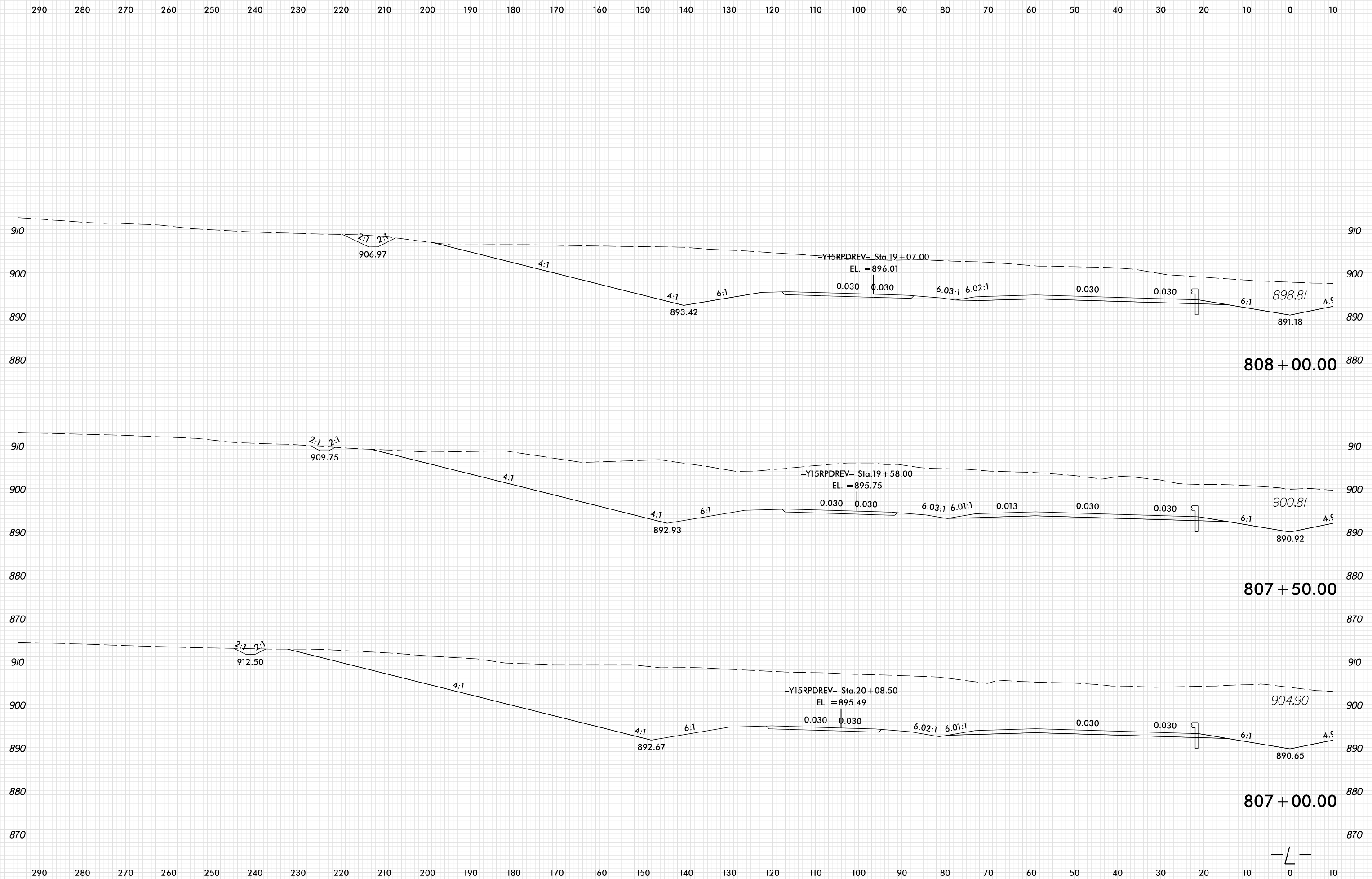

PLOT DRIVER: NCDOT_pdf_color_eng_100.plt
 USER: SPEREIRA
 DATE: 6/10/2021
 TIME: 2:16:30 PM
 FILE: \

8/23/99

0 5 10	PROJ. REFERENCE NO.	SHEET NO.
	U-2579AB	X-70

290 280 270 260 250 240 230 220 210 200 190 180 170 160 150 140 130 120 110 100 90 80 70 60 50 40 30 20 10 0 10

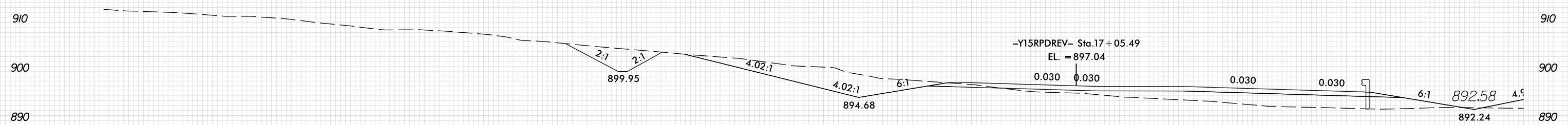

810 + 00.00

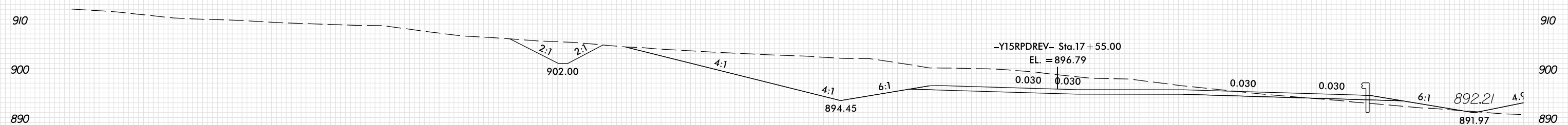

809 + 50.00

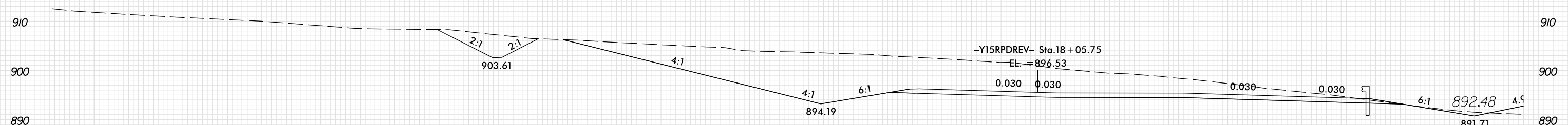

809 + 00.00

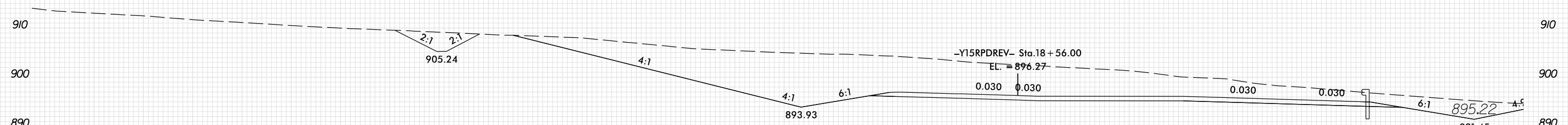

808 + 50.00

290 280 270 260 250 240 230 220 210 200 190 180 170 160 150 140 130 120 110 100 90 80 70 60 50 40 30 20 10 0 10

PLOT DRIVER: NCDOT_pdf_color_eng_100.plt
 USER: SPEREIRA
 DATE: 6/10/2021
 TIME: 2:16:30 PM
 FILE: \

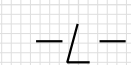

8/23/99

290 280 270 260 250 240 230 220 210 200 190 180 170 160 150 140 130 120 110 100 90 80 70 60 50 40 30 20 10 0 10

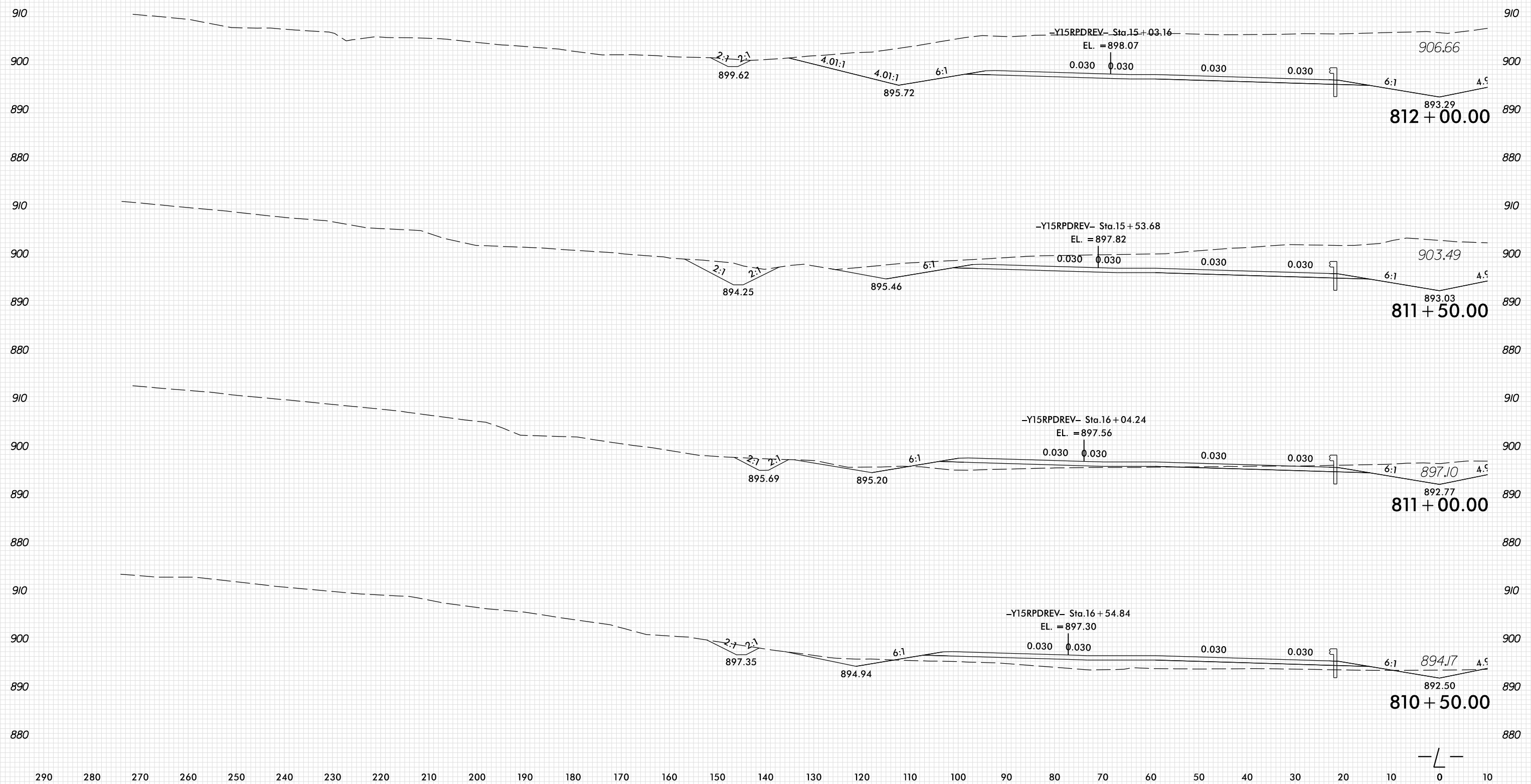

PLOT DRIVER: NCDOT_pdf_color_eng_100.plt
 USER: SPEREIRA
 DATE: 6/10/2021
 TIME: 2:16:31 PM
 FILE: \

290 280 270 260 250 240 230 220 210 200 190 180 170 160 150 140 130 120 110 100 90 80 70 60 50 40 30 20 10 0 10

8/23/99

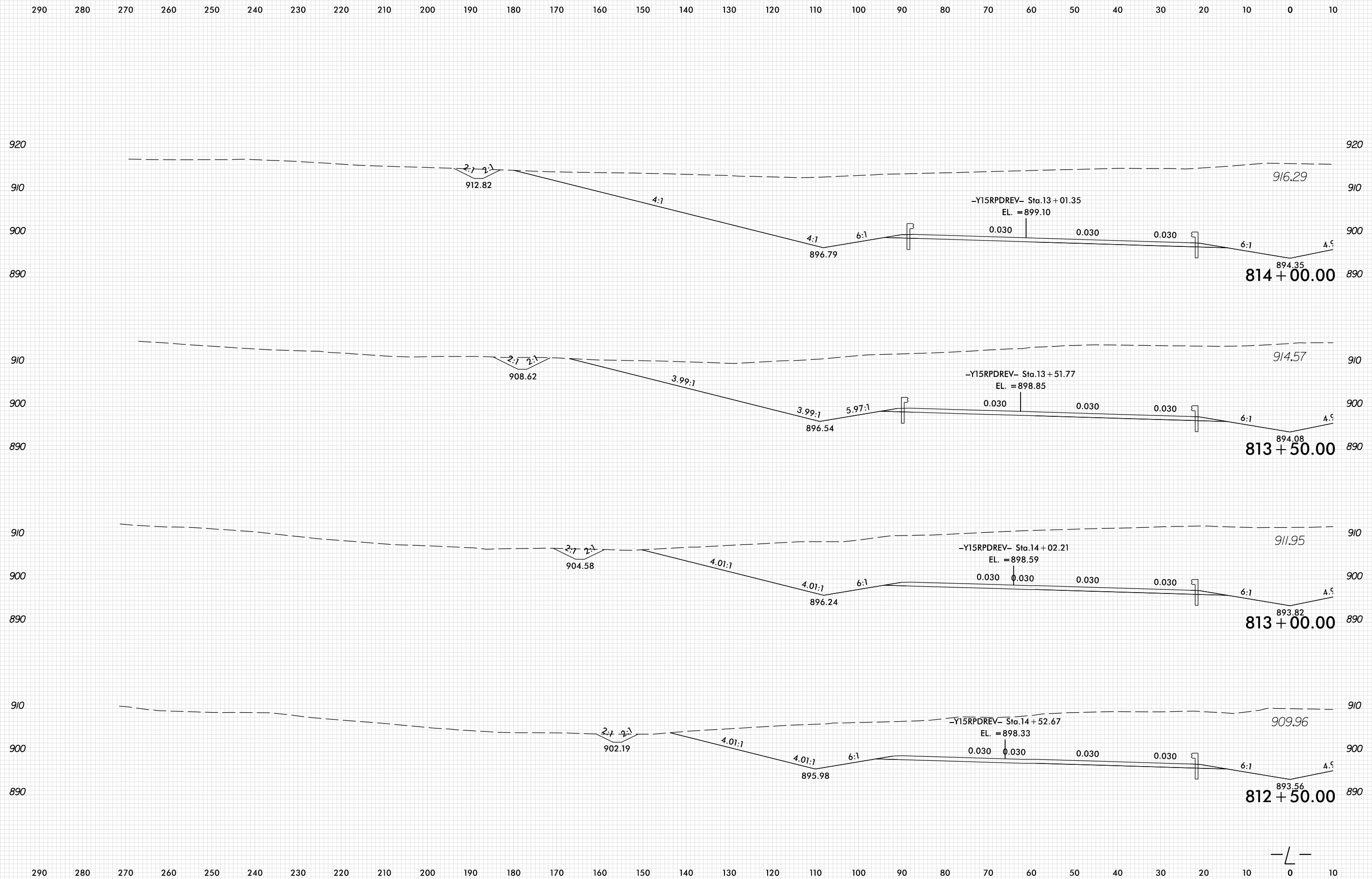

PLOT DRIVER: NCDOT_pdf_color_eng_100.plt
 USER: SPEREIRA
 DATE: 6/10/2021
 TIME: 2:16:31 PM
 FILE: \

8/23/99

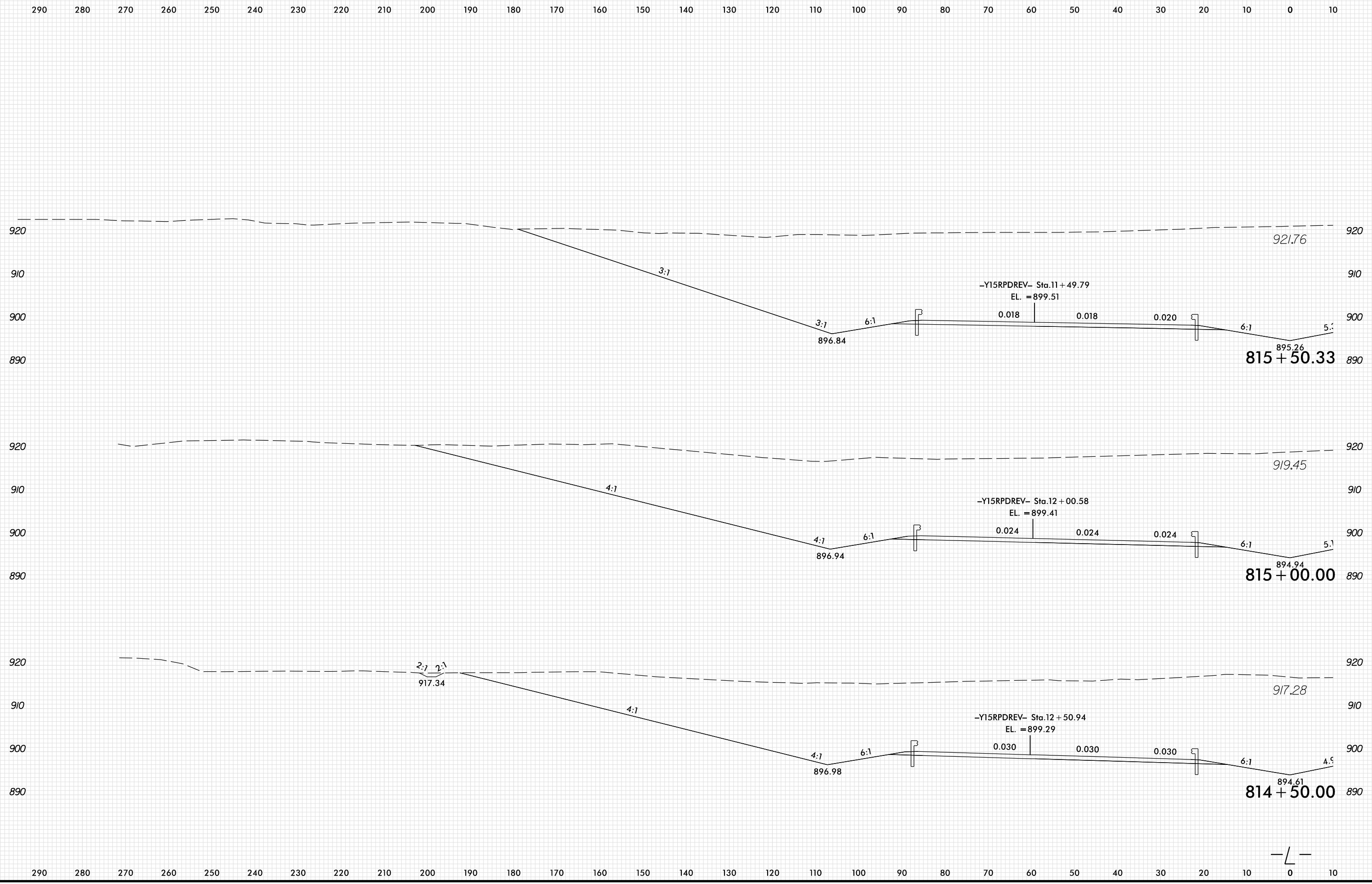

PLOT DRIVER: NCDOT_pdf_color_eng_100.plt
 USER: SPEREIRA
 DATE: 6/10/2021
 TIME: 2:16:32 PM
 FILE: \

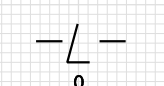

8/23/99

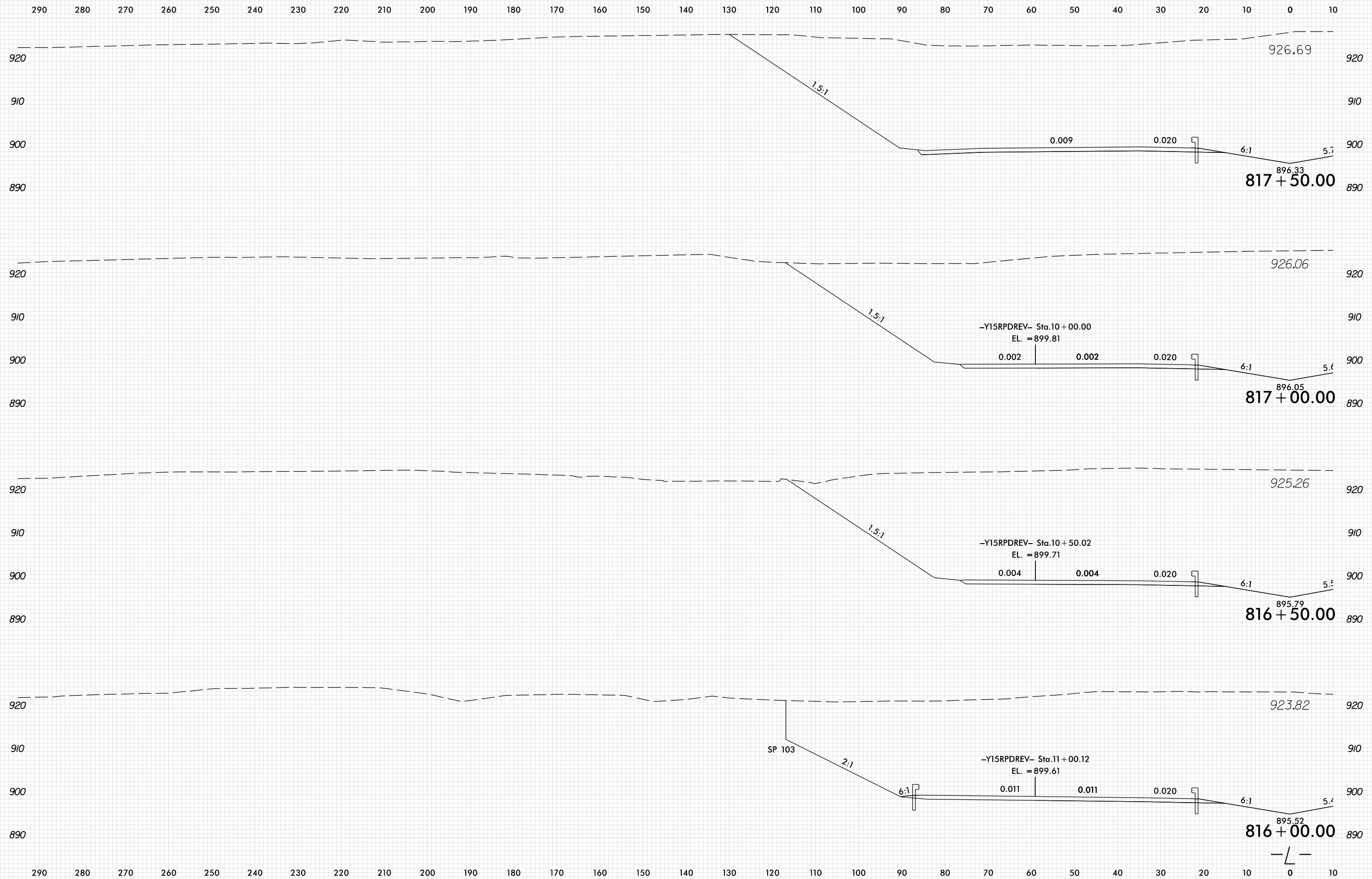

PLOT DRIVER: NCDOT_pdf_color_eng_100.plt
 USER: SPEREIRA
 DATE: 6/10/2021
 TIME: 2:16:33 PM
 FILE: \

8/23/99

0 5 10	PROJ. REFERENCE NO.	SHEET NO.
	U-2579AB	X-75

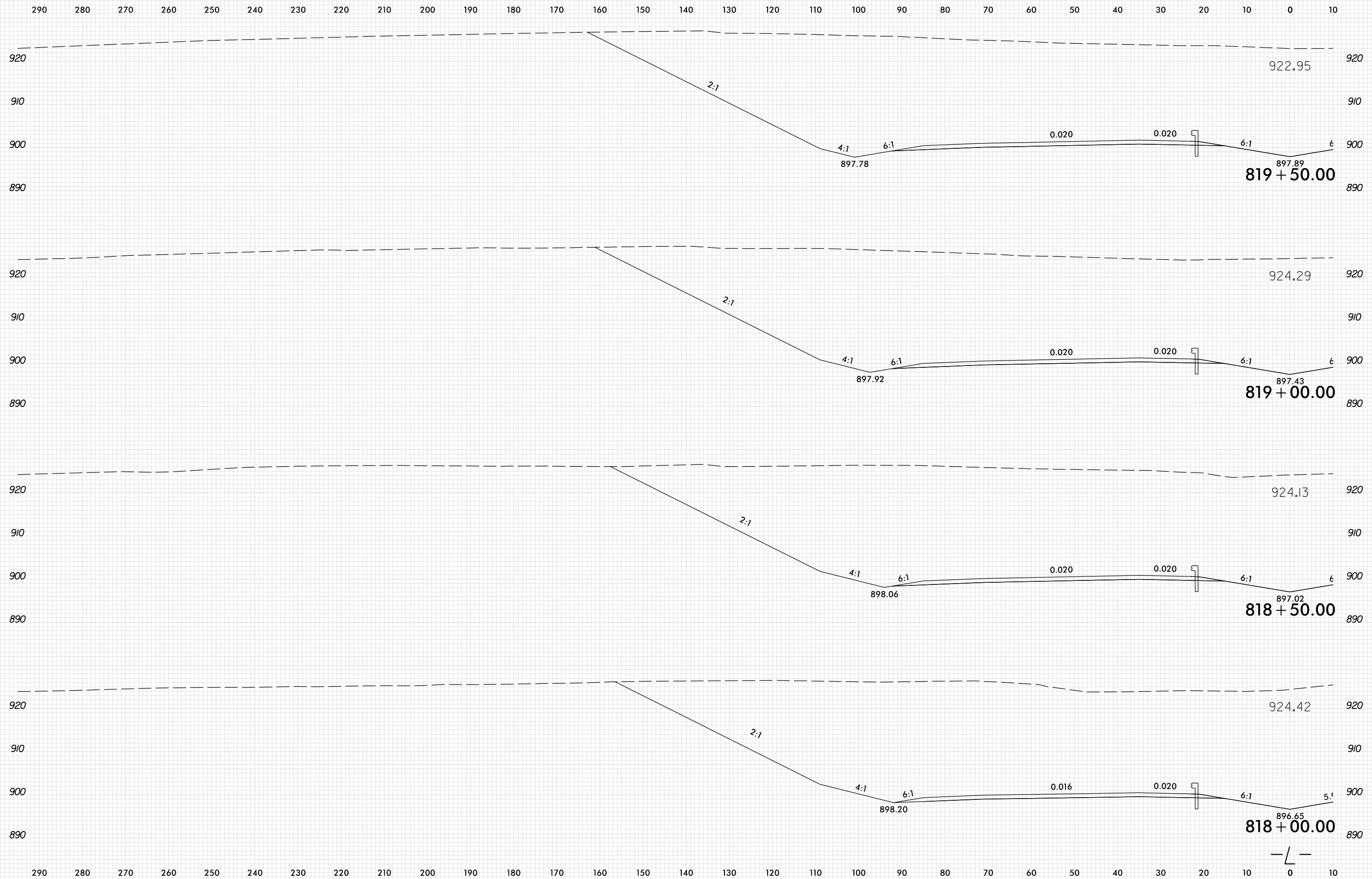

PLOT DRIVER: NCDOT_pdf_color_eng_100.plt
 USER: SPEREIRA
 DATE: 6/10/2021
 TIME: 2:16:33 PM
 FILE: \

8/23/99

0 5 10	PROJ. REFERENCE NO.	SHEET NO.
	U-2579AB	X-76

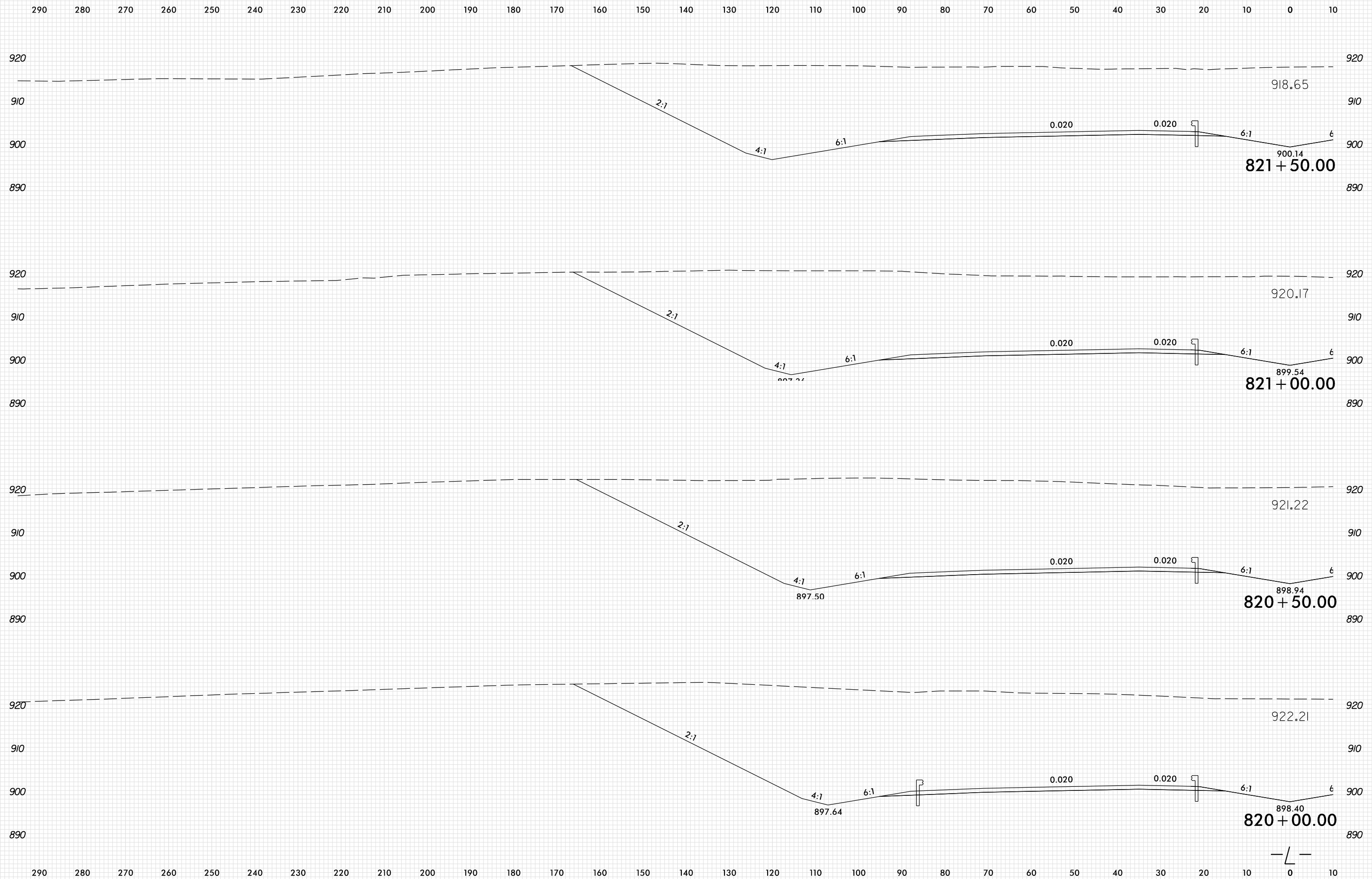

PLOT DRIVER: NCDOT_pdf_color_eng_100.plt
 USER: SPEREIRA
 DATE: 6/10/2021
 TIME: 2:16:34 PM
 FILE: \

8/23/99

0 5 10	PROJ. REFERENCE NO.	SHEET NO.
	U-2579AB	X-77

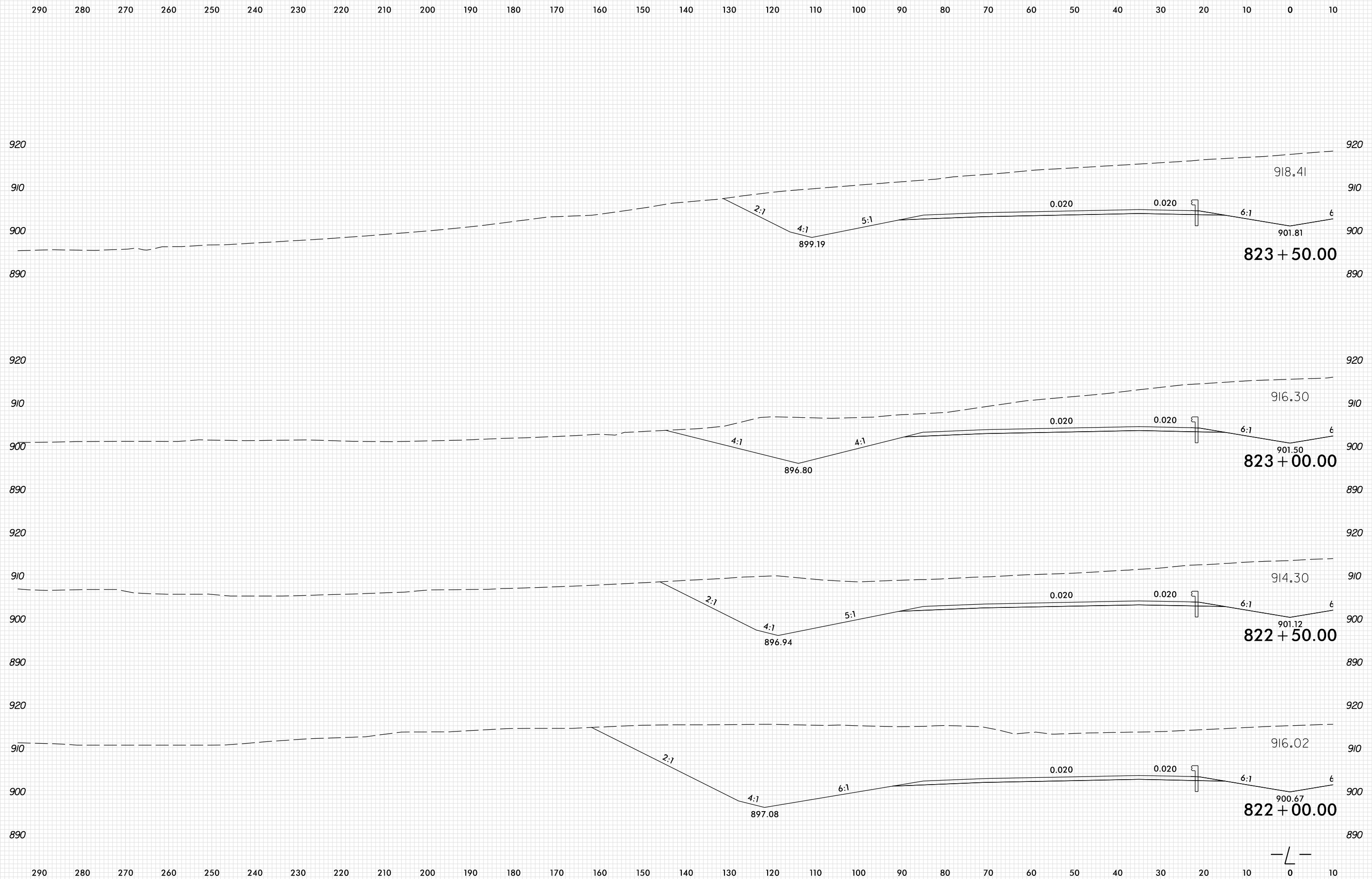

PLOT DRIVER: NCDOT_pdf_color_eng_100.plt
 USER: SPEREIRA
 DATE: 6/10/2021
 TIME: 2:16:35 PM
 FILE: \

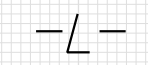

8/23/99

0 5 10	PROJ. REFERENCE NO.	SHEET NO.
	U-2579AB	X-78

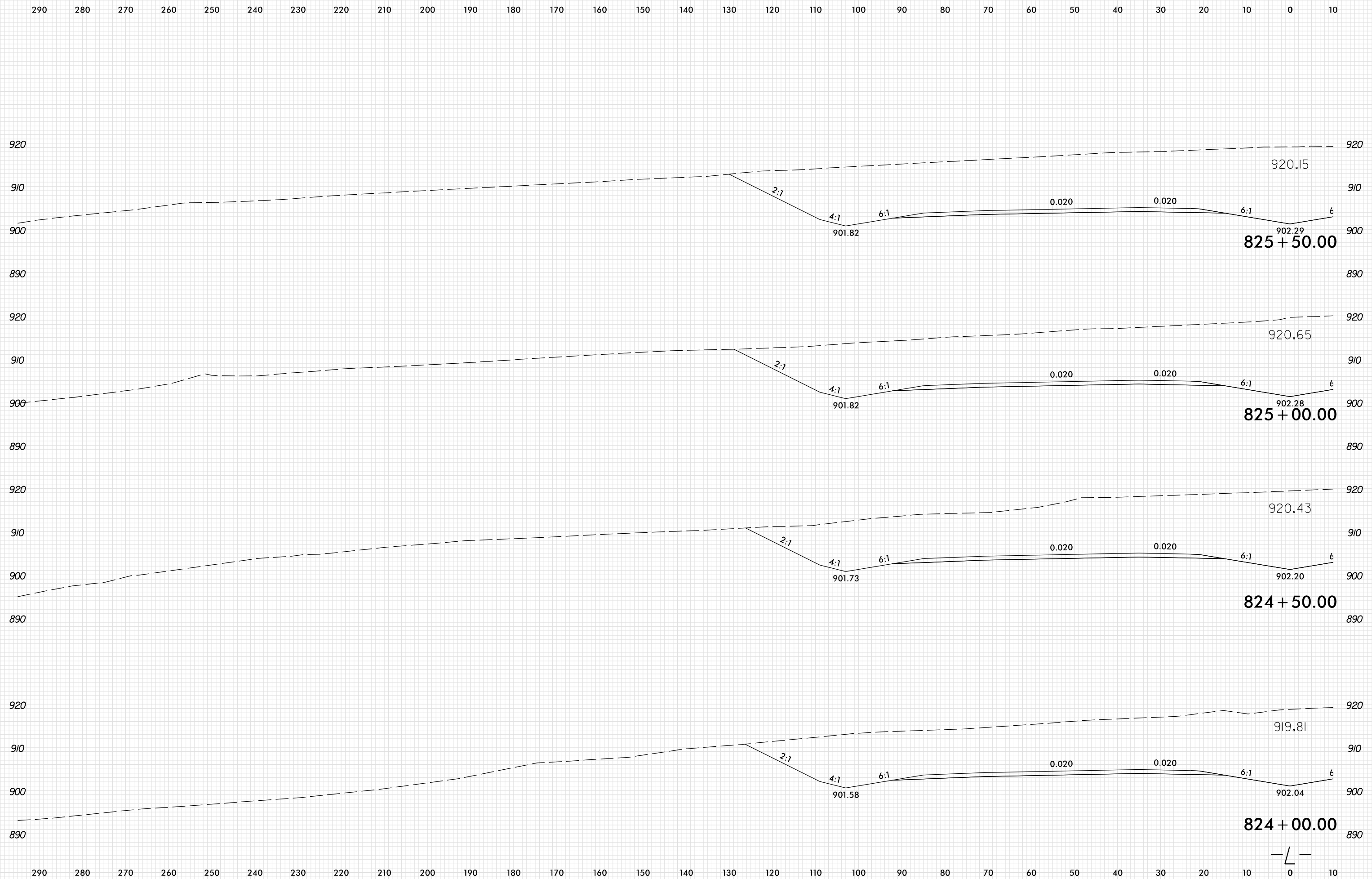

PLOT DRIVER: NCDOT_pdf_color_eng_100.plt
 USER: SPEREIRA
 DATE: 6/10/2021
 TIME: 2:16:35 PM
 FILE: \

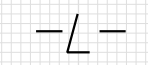

8/23/99

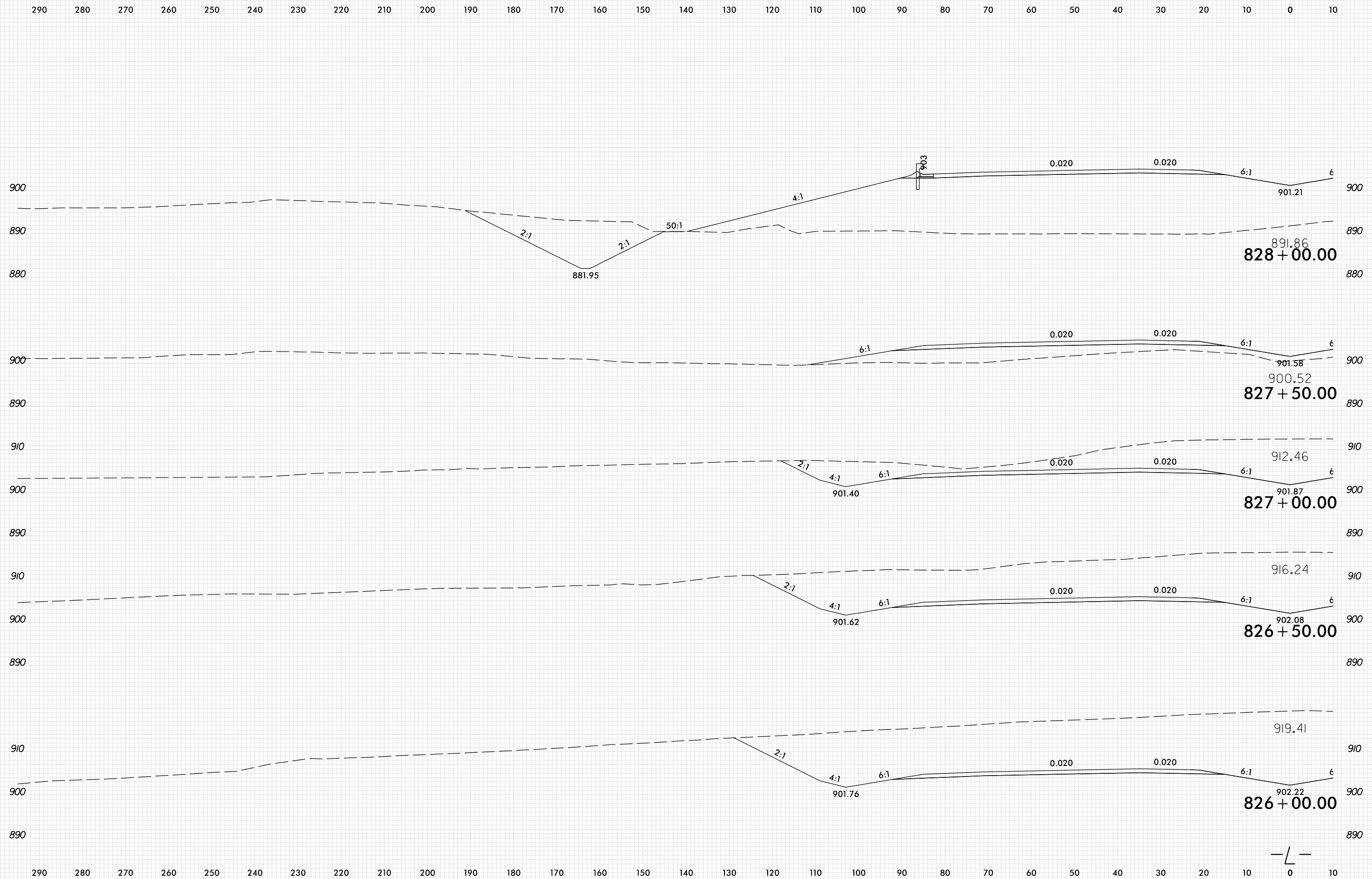

PLOT DRIVER: NCDOT_pdf_color_eng_100.plt
 USER: SPEREIRA
 DATE: 6/10/2021
 TIME: 2:16:36 PM
 FILE: \

8/23/99

0 5 10	PROJ. REFERENCE NO.	SHEET NO.
	U-2579AB	X-80

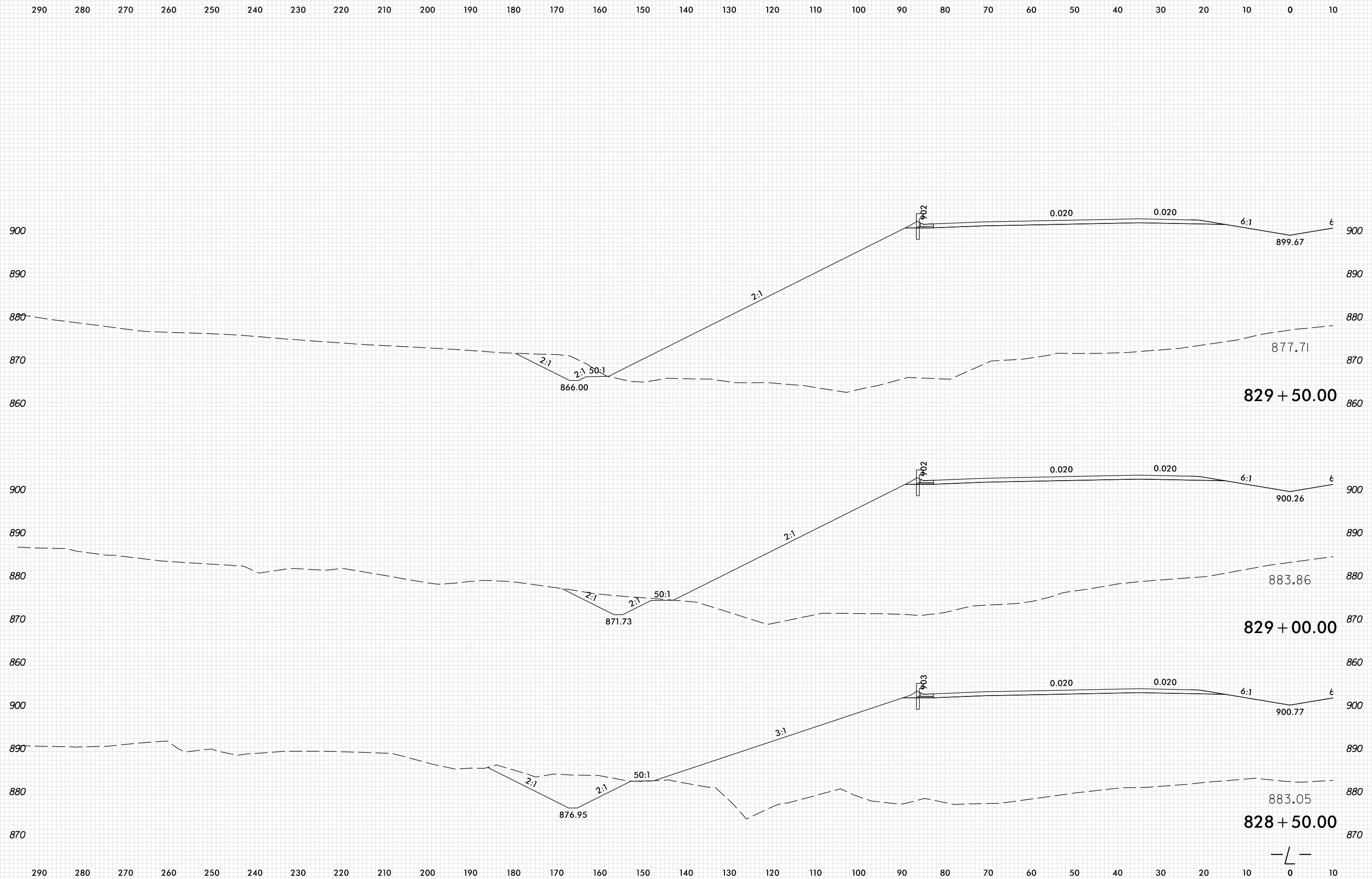

PLOT DRIVER: NCDOT_pdf_color_eng_100.plt
 USER: SPEREIRA
 DATE: 6/10/2021
 TIME: 2:16:37 PM
 FILE: \

829 + 50.00

829 + 00.00

828 + 50.00

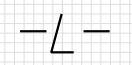

8/23/99

0 5 10	PROJ. REFERENCE NO.	SHEET NO.
	U-2579AB	X-81

290 280 270 260 250 240 230 220 210 200 190 180 170 160 150 140 130 120 110 100 90 80 70 60 50 40 30 20 10 0 10

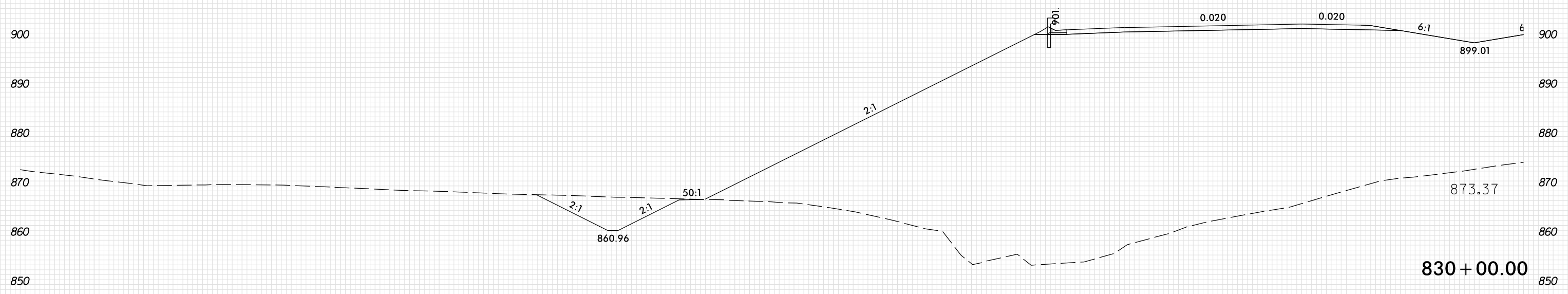
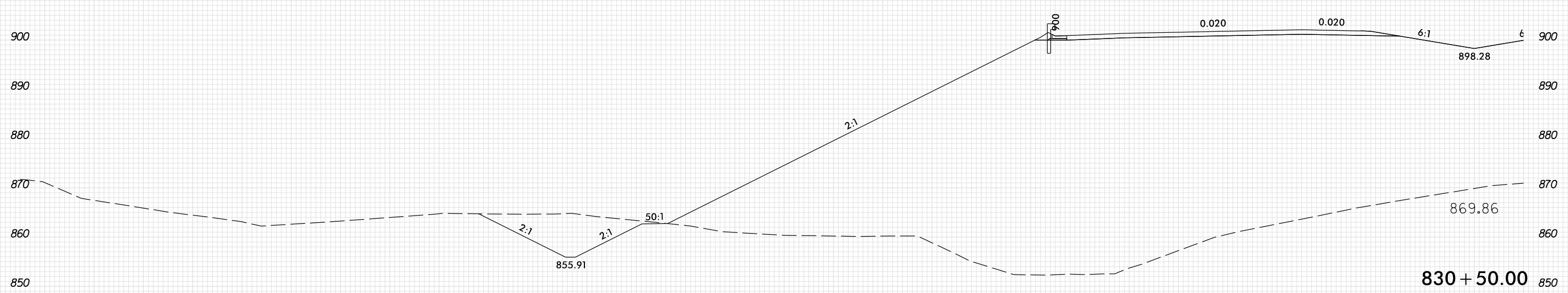

290 280 270 260 250 240 230 220 210 200 190 180 170 160 150 140 130 120 110 100 90 80 70 60 50 40 30 20 10 0 10

PLOT DRIVER: NCDOT_pdf_color_eng_100.plt
 USER: SPEREIRA
 DATE: 6/10/2021
 TIME: 2:16:37 PM
 FILE: \

8/23/99

0 5 10	PROJ. REFERENCE NO.	SHEET NO.
	U-2579AB	X-82

290 280 270 260 250 240 230 220 210 200 190 180 170 160 150 140 130 120 110 100 90 80 70 60 50 40 30 20 10 0 10

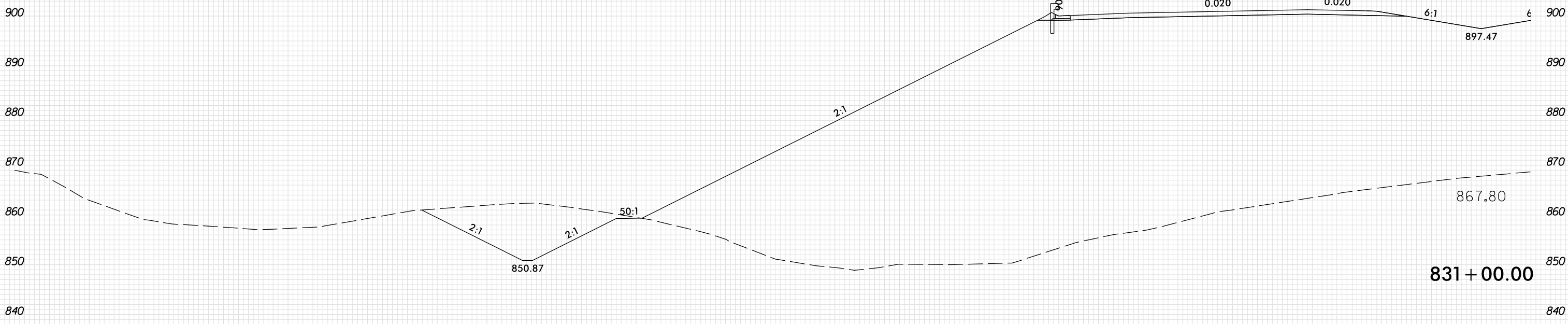
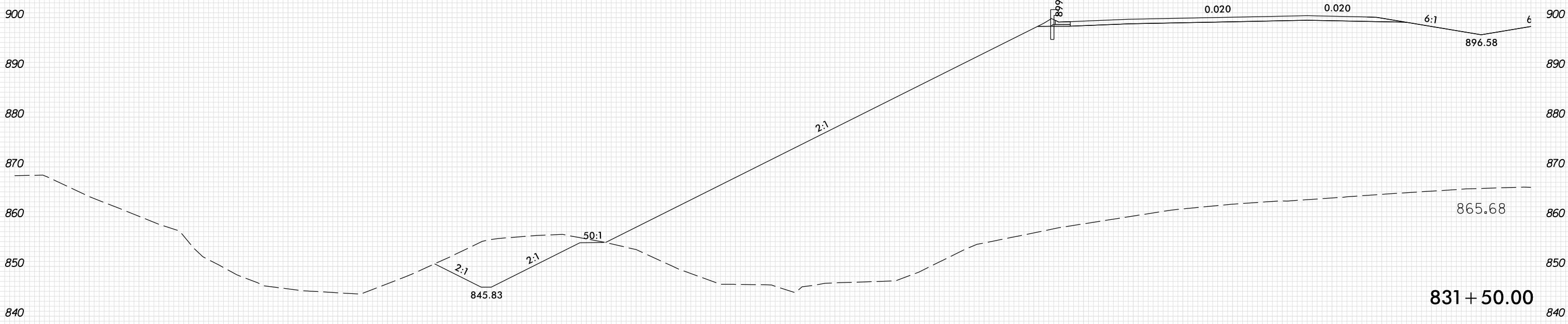

290 280 270 260 250 240 230 220 210 200 190 180 170 160 150 140 130 120 110 100 90 80 70 60 50 40 30 20 10 0 10

PLOT DRIVER: NCDOT_pdf_color_eng_100.plt
 USER: SPEREIRA
 DATE: 6/10/2021
 TIME: 2:16:38 PM
 FILE: \

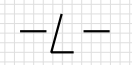

8/23/99

0 5 10	PROJ. REFERENCE NO.	SHEET NO.
	U-2579AB	X-83

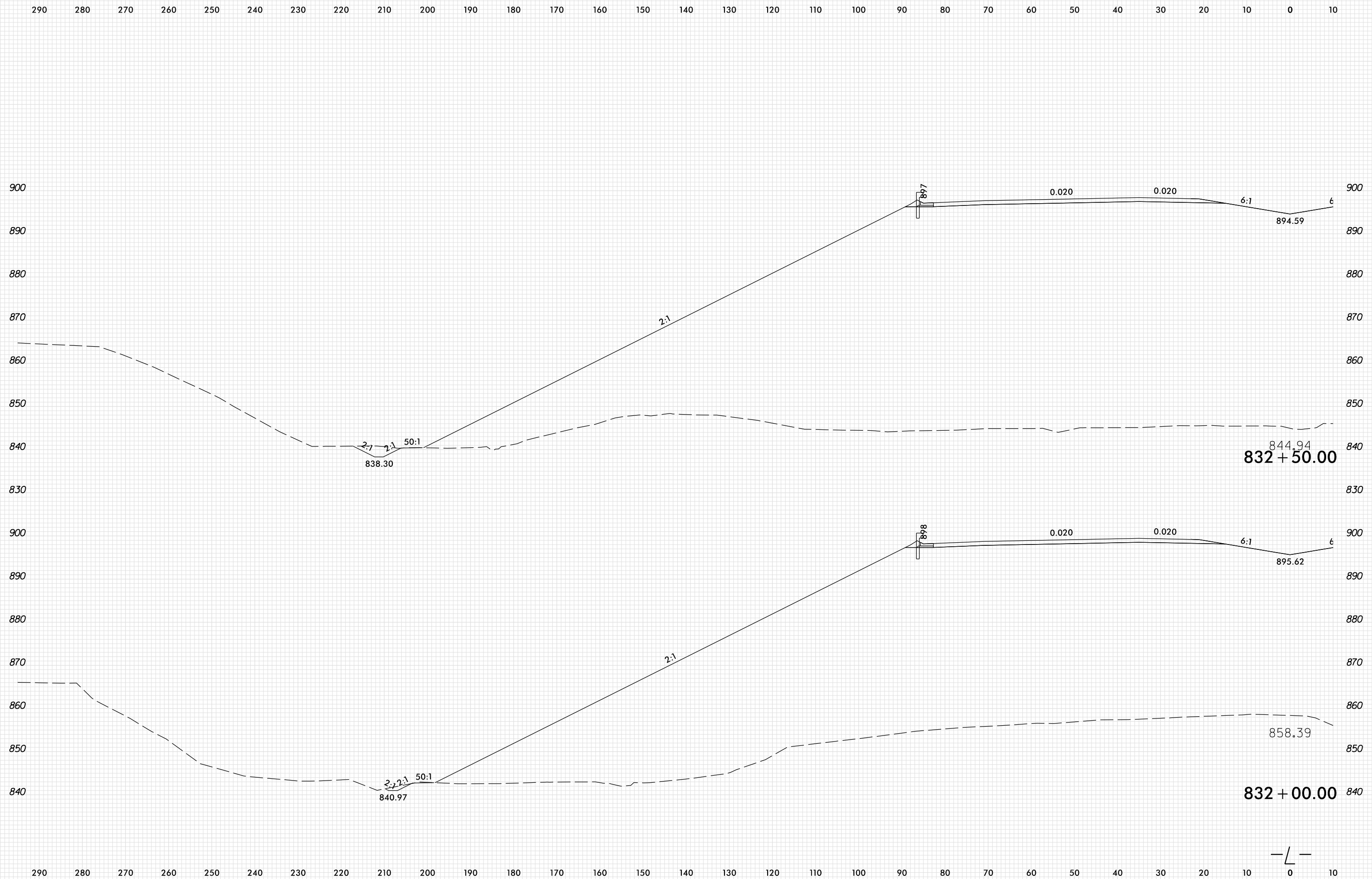

PLOT DRIVER: NCDOT_pdf_color_eng_100.plt
 USER: SPEREIRA
 DATE: 6/10/2021
 TIME: 2:16:38 PM
 FILE: \

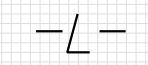

8/23/99

0 5 10	PROJ. REFERENCE NO.	SHEET NO.
	U-2579AB	X-84

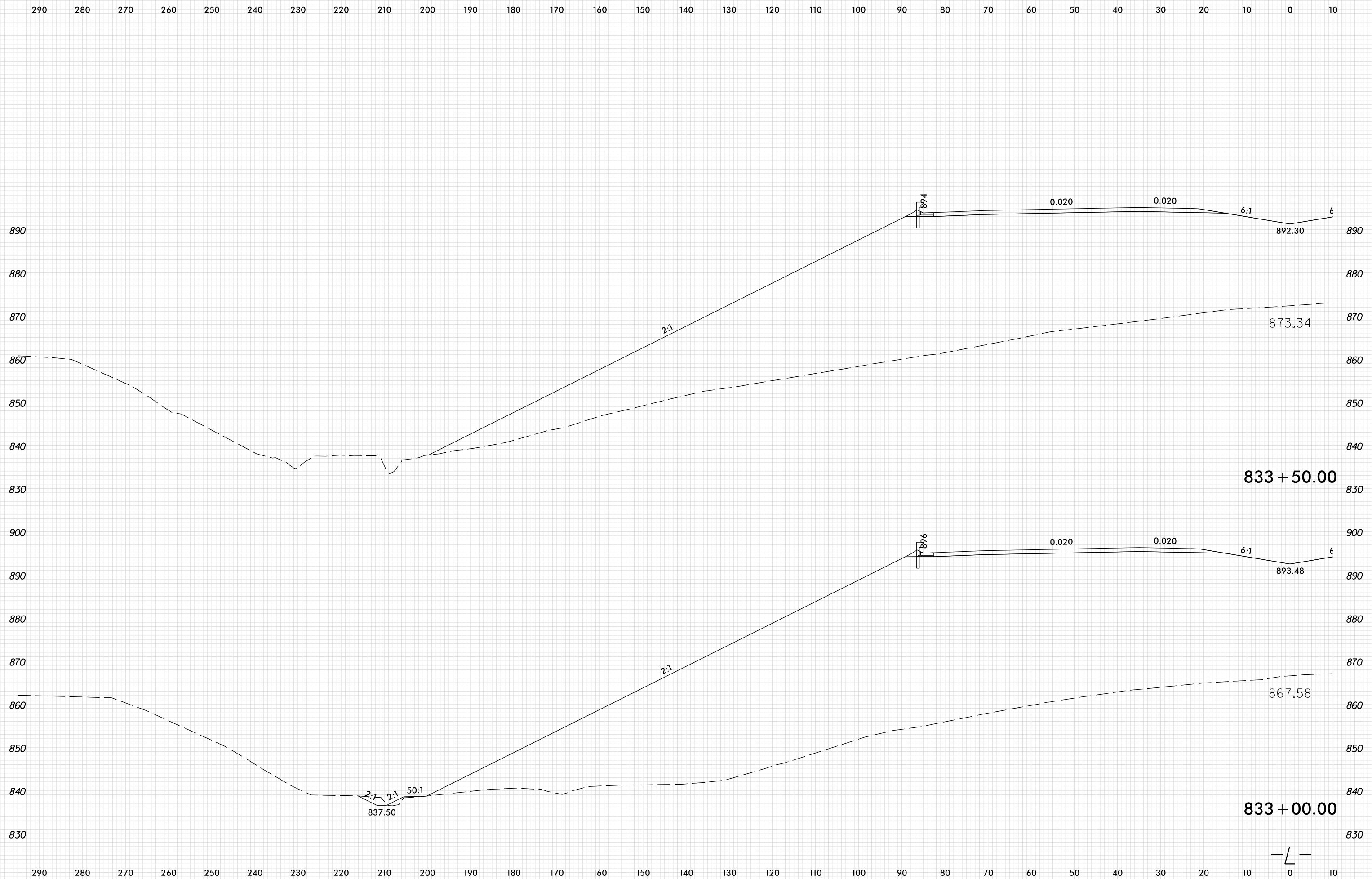

PLOT DRIVER: NCDOT_pdf_color_eng_100.plt
 USER: SPEREIRA
 DATE: 6/10/2021
 TIME: 2:16:39 PM
 FILE: \

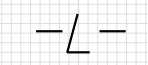

8/23/99

	PROJ. REFERENCE NO.	SHEET NO.
	U-2579AB	X-85

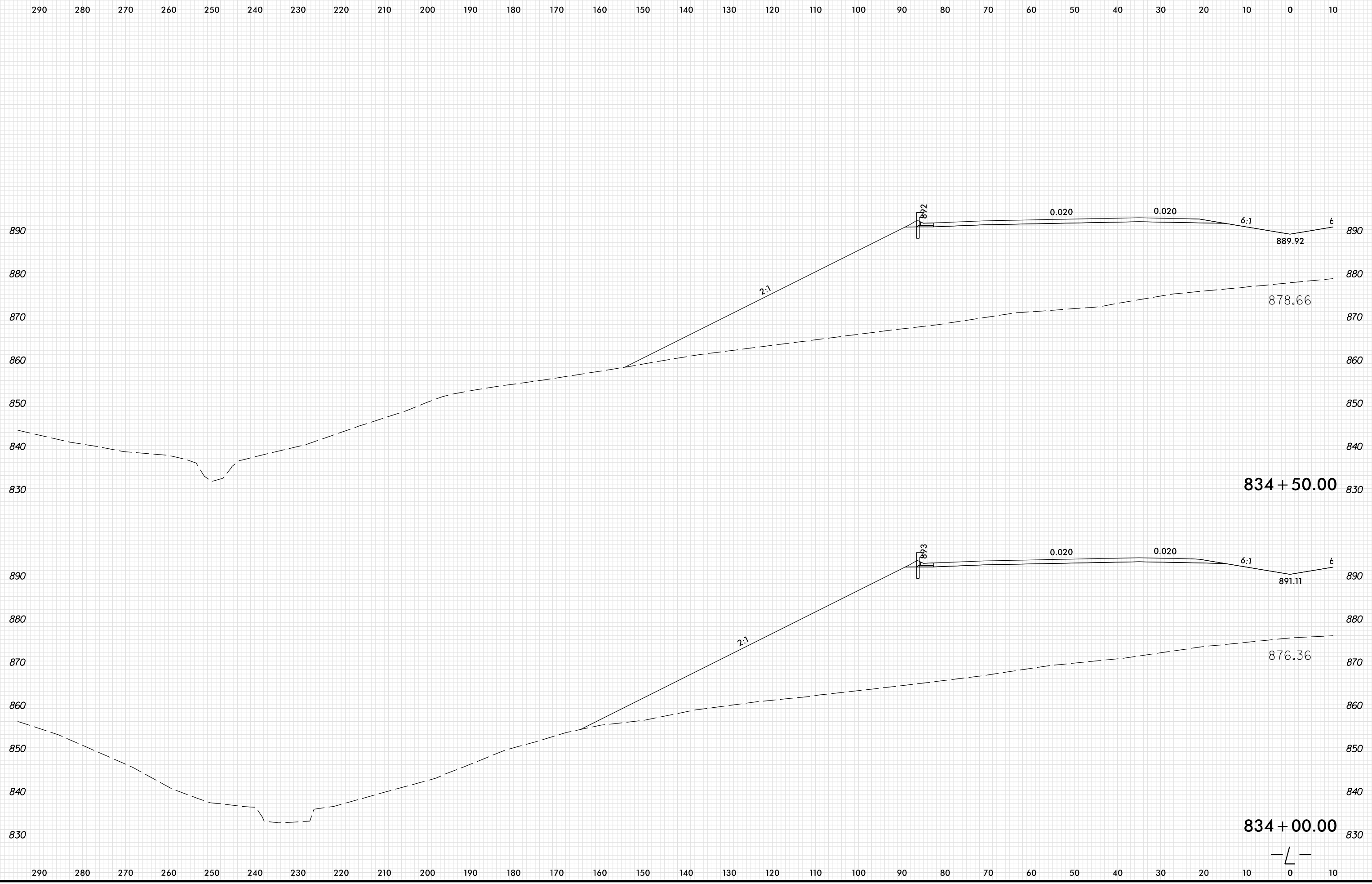

PLOT DRIVER: NCD01_pdf_color_eng_100.plt
 USER: SPEREIRA
 DATE: 6/10/2021
 TIME: 2:16:40 PM
 FILE: \

8/23/99

	PROJ. REFERENCE NO.	SHEET NO.
	U-2579AB	X-86

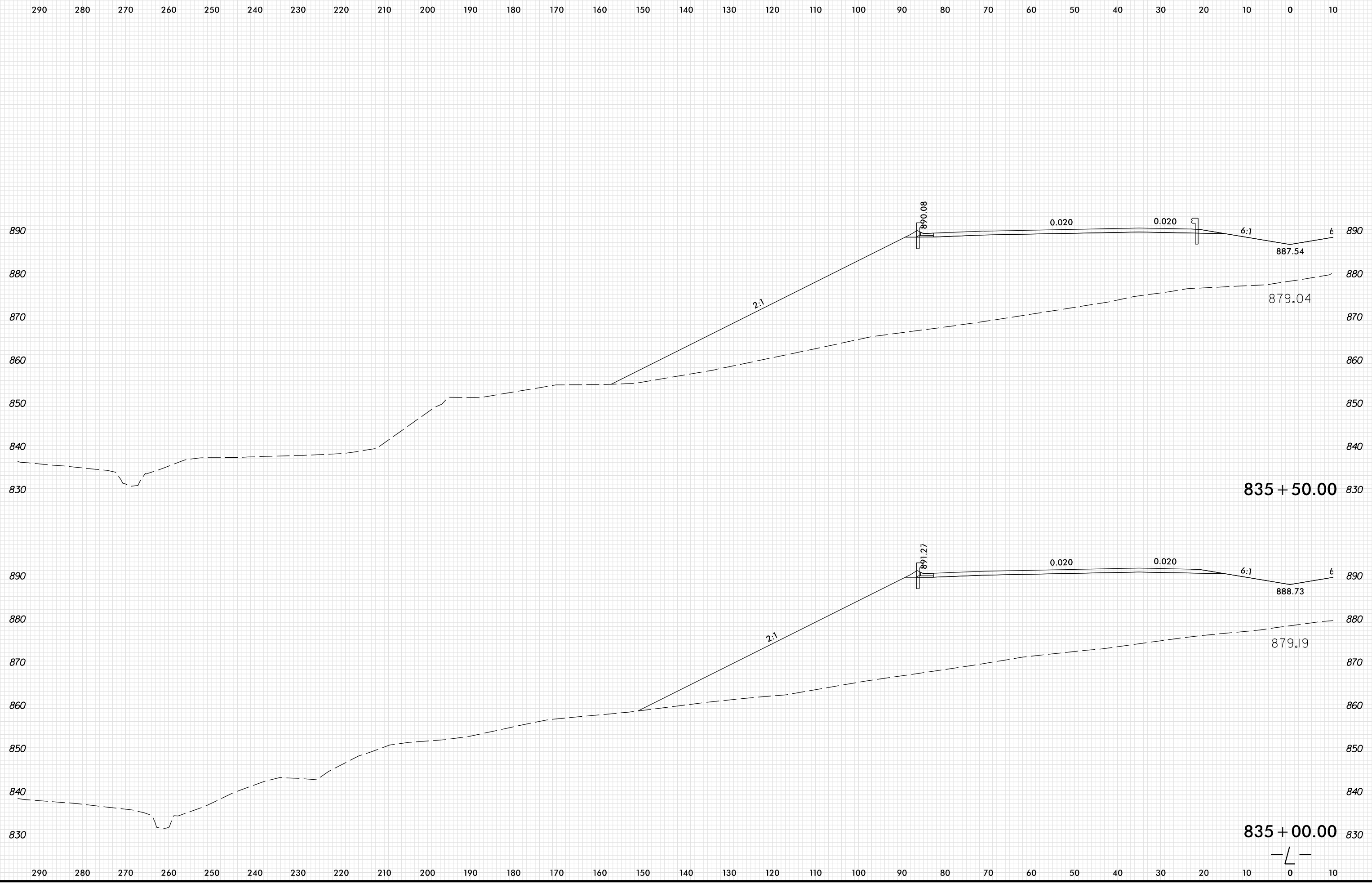

PLOT DRIVER: NCD01_pdf_color_eng_100.plt
 USER: SPEREIRA
 DATE: 6/10/2021
 TIME: 2:16:40 PM
 FILE: \

8/23/99

	PROJ. REFERENCE NO.	SHEET NO.
	U-2579AB	X-86A

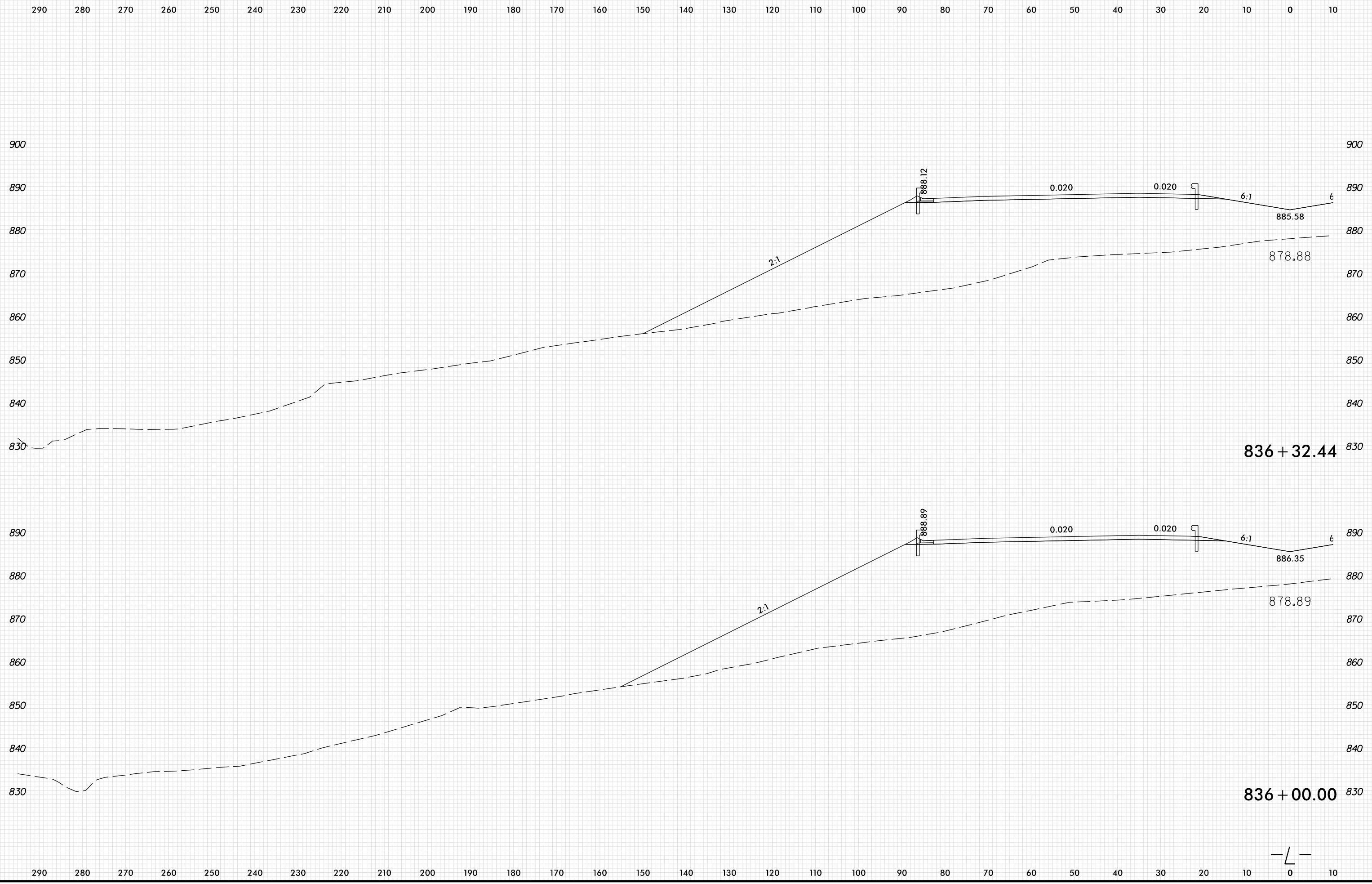

PLOT DRIVER: NCDOT_pdf_color_eng_100.plt
 USER: SPEREIRA
 DATE: 6/10/2021
 TIME: 2:16:41 PM
 FILE: \

—L—

10 0 10 20 30 40 50 60 70 80 90 100 110 120 130 140 150 160 170 180 190 200 210 220 230 240 250 260 270 280 290

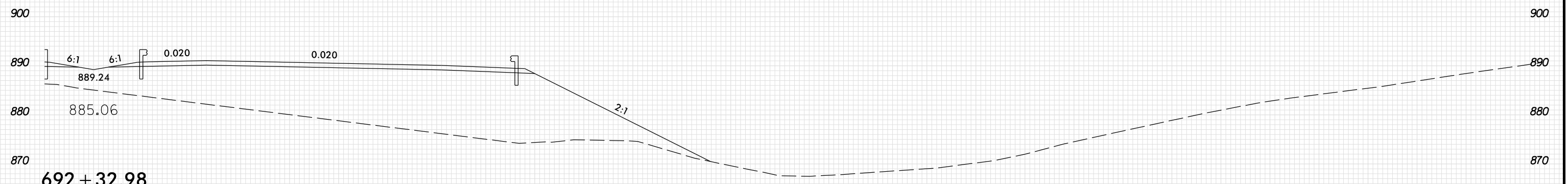
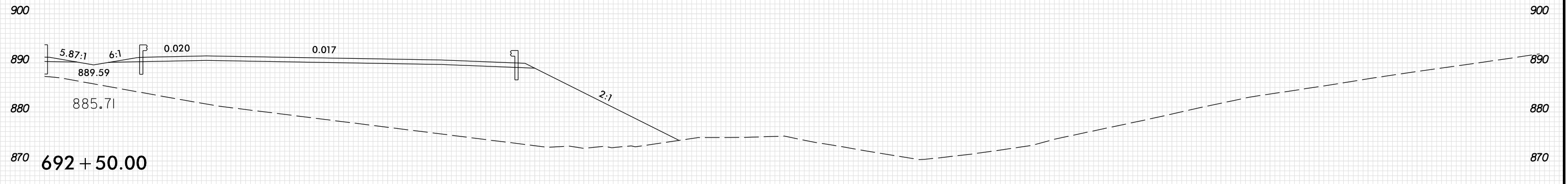
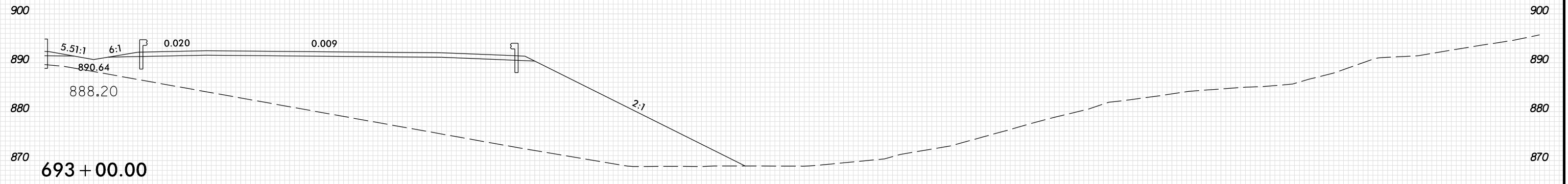

10 0 10 20 30 40 50 60 70 80 90 100 110 120 130 140 150 160 170 180 190 200 210 220 230 240 250 260 270 280 290

8/23/99

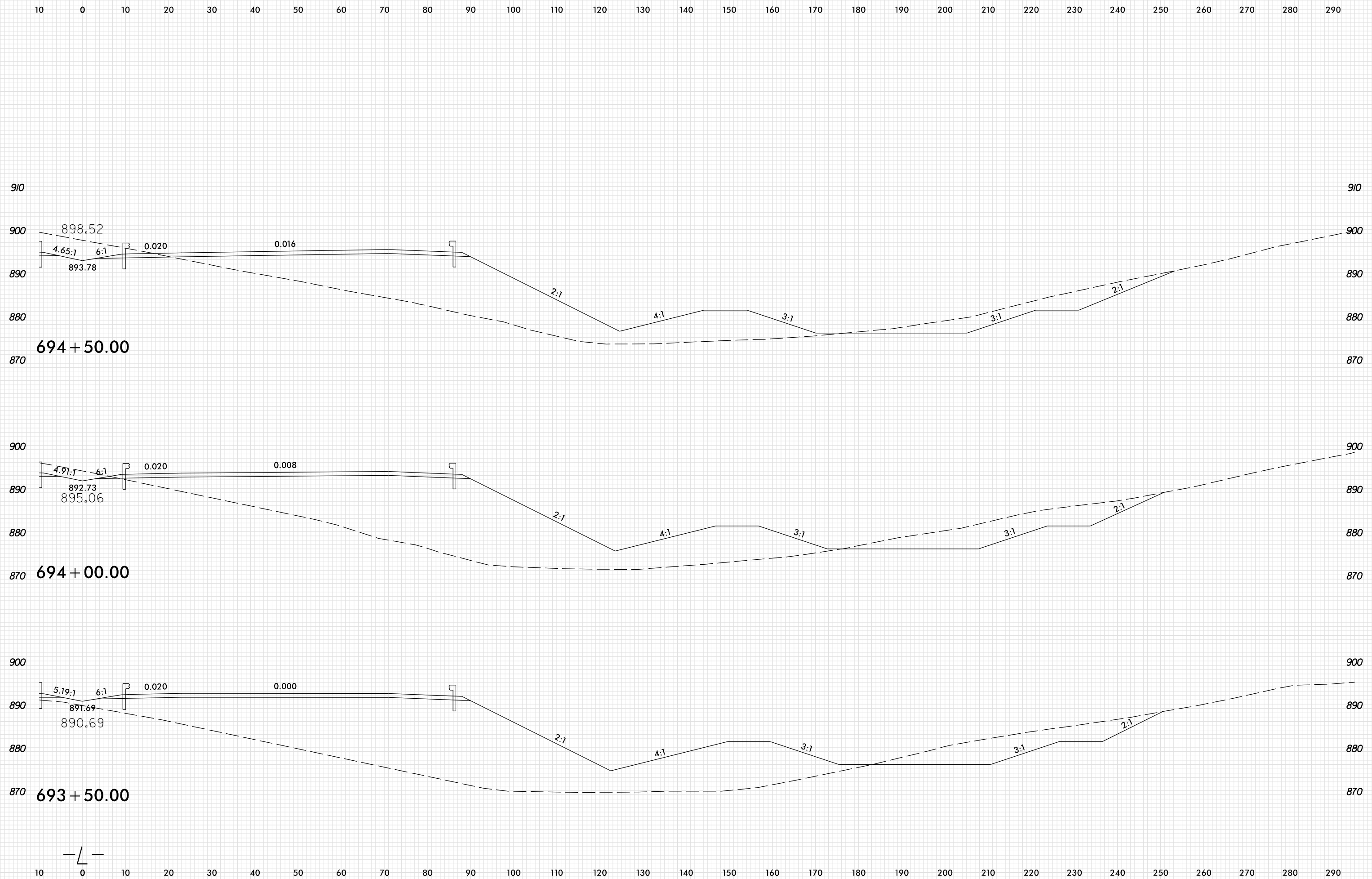

PLOT DRIVER: NCDOT_pdf_color_eng_100.plt
 USER: SPEREIRA
 DATE: 6/10/2021
 TIME: 2:17:36 PM
 FILE: \



8/23/99

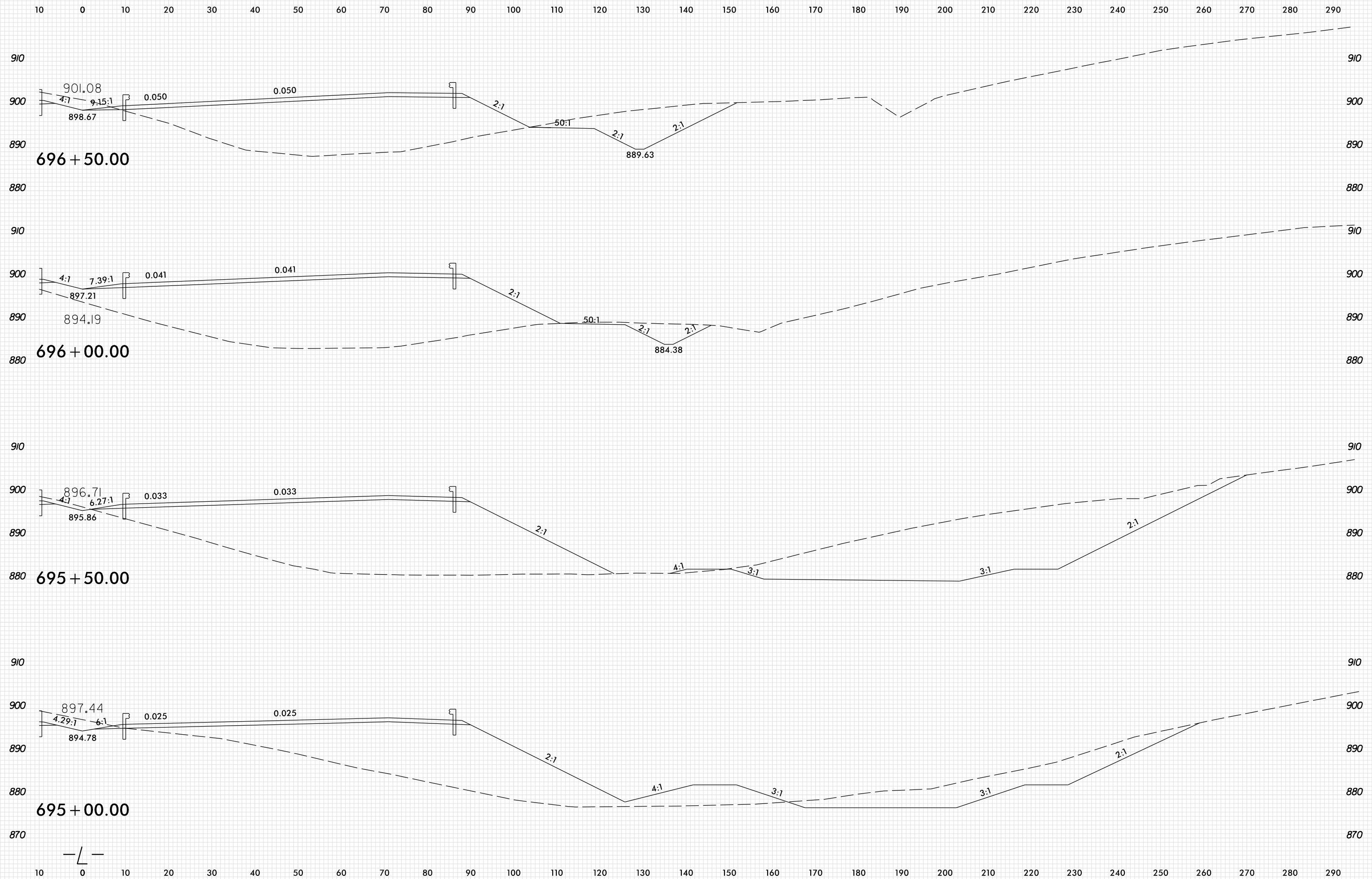

PLOT DRIVER: NCD01_pdf_color_eng_100.plt
 USER: SPEREIRA
 DATE: 6/10/2021
 TIME: 2:17:37 PM
 FILE: \

8/23/99

0 5 10	PROJ. REFERENCE NO.	SHEET NO.
	U-2579AB	X-90

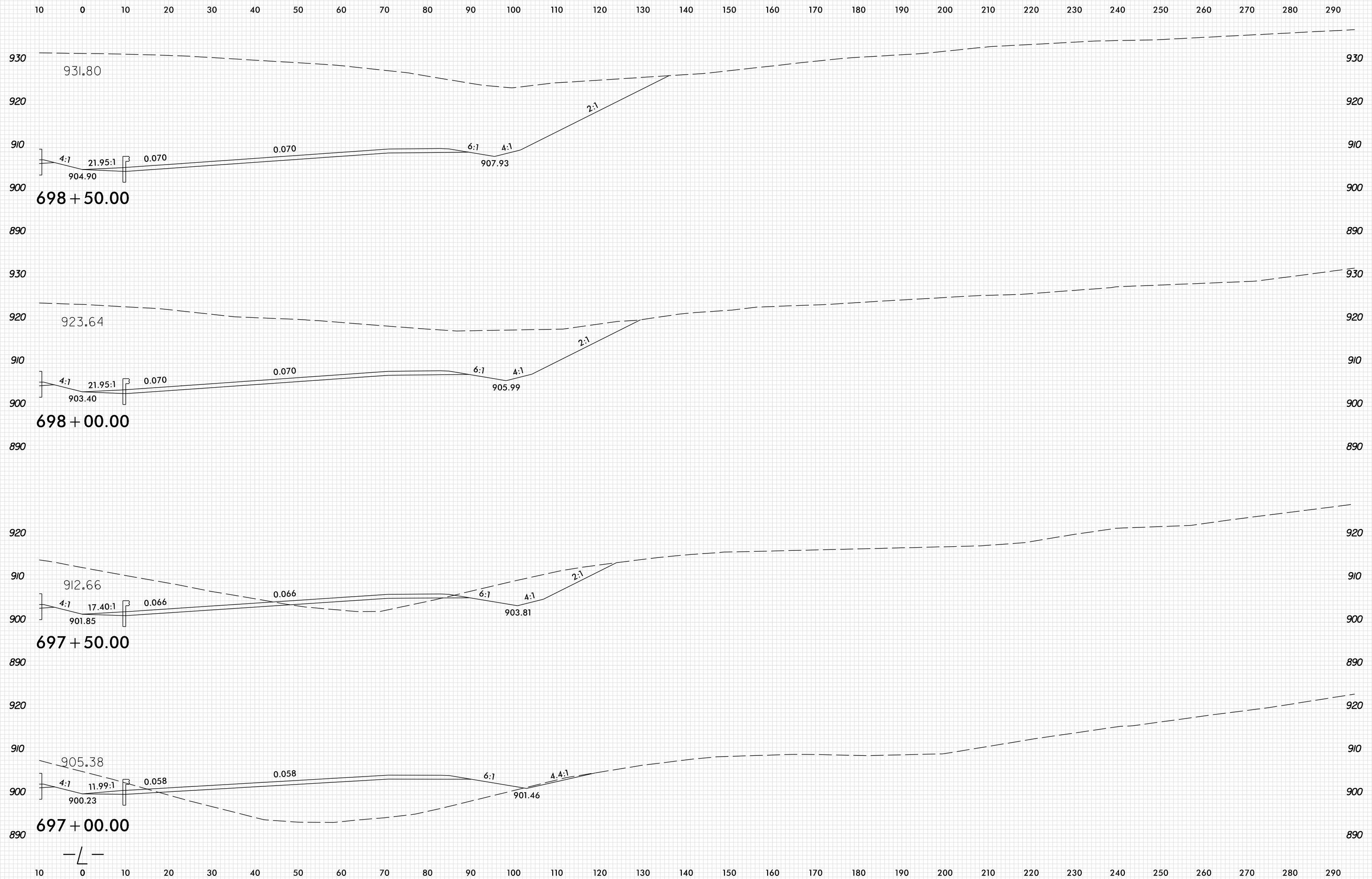

PLOT DRIVER: NCDOT_pdf_color_eng_100.plt
 USER: SPEREIRA
 DATE: 6/10/2021
 TIME: 2:17:38 PM
 FILE: \

8/23/99

0 5 10	PROJ. REFERENCE NO.	SHEET NO.
	U-2579AB	X-91

10 0 10 20 30 40 50 60 70 80 90 100 110 120 130 140 150 160 170 180 190 200 210 220 230 240 250 260 270 280 290

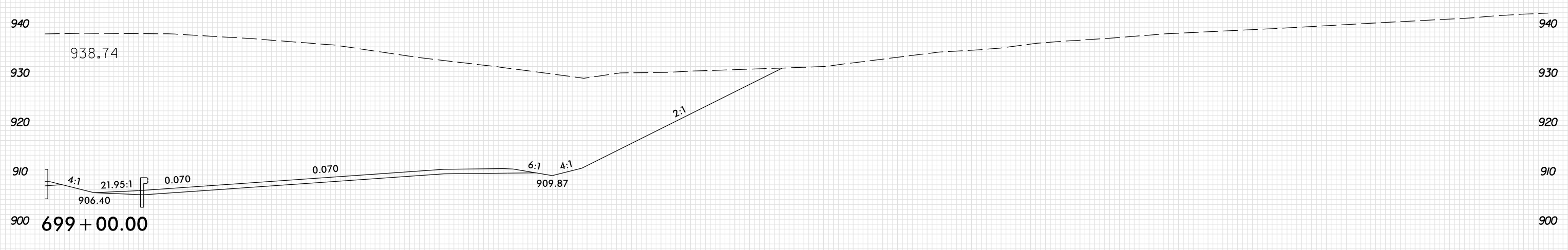
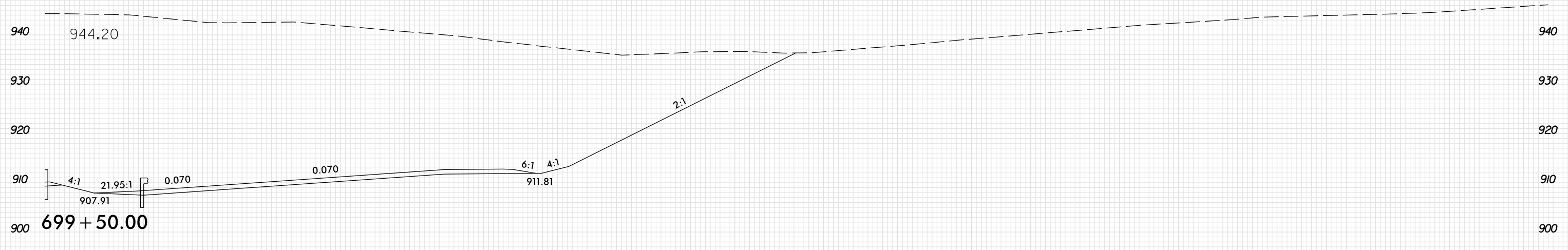
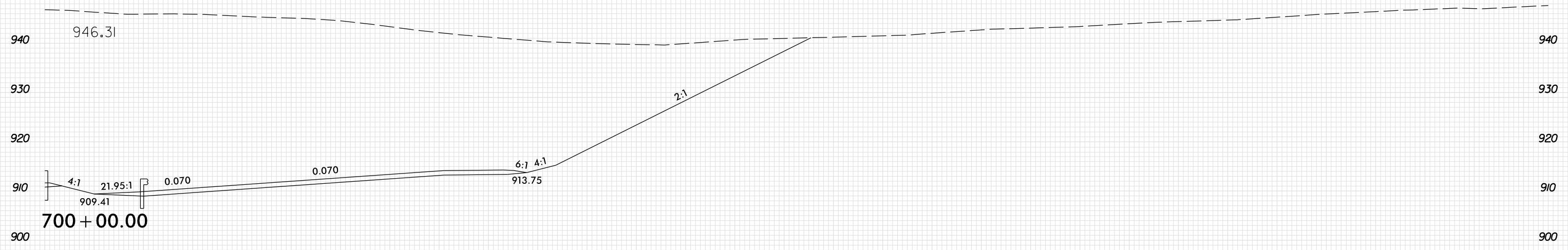

10 0 10 20 30 40 50 60 70 80 90 100 110 120 130 140 150 160 170 180 190 200 210 220 230 240 250 260 270 280 290

PLOT DRIVER: NCDOT_pdf_color_eng_100.plt
 USER: SPEREIRA
 DATE: 6/10/2021
 TIME: 2:17:38 PM
 FILE: \



8/23/99

0 5 10	PROJ. REFERENCE NO.	SHEET NO.
	U-2579AB	X-92

10 0 10 20 30 40 50 60 70 80 90 100 110 120 130 140 150 160 170 180 190 200 210 220 230 240 250 260 270 280 290

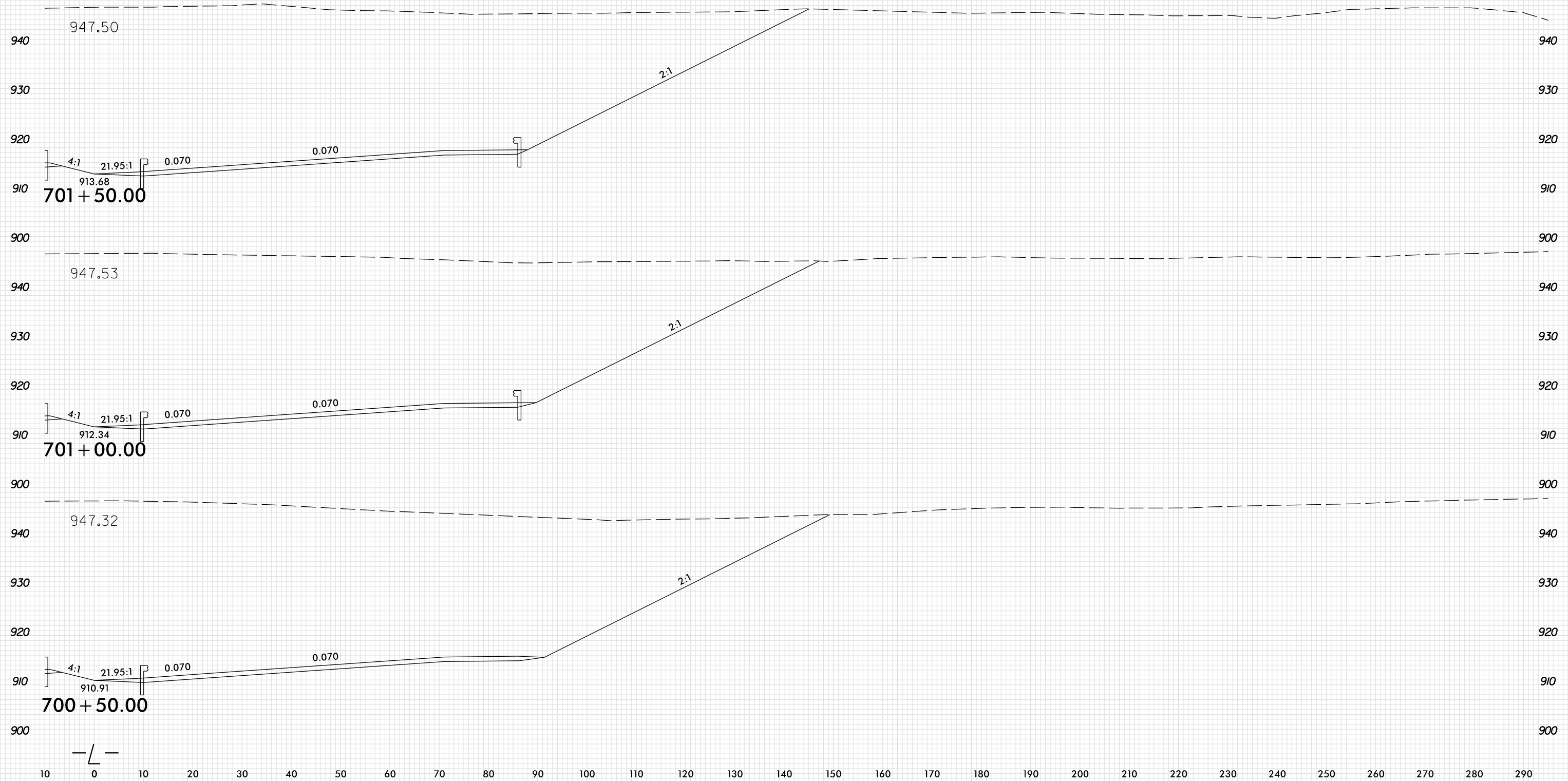

PLOT DRIVER: NCDOT_pdf_color_eng_100.plt
 USER: SPEREIRA
 DATE: 6/10/2021
 TIME: 2:17:39 PM



8/23/99

10 0 10 20 30 40 50 60 70 80 90 100 110 120 130 140 150 160 170 180 190 200 210 220 230 240 250 260 270 280 290

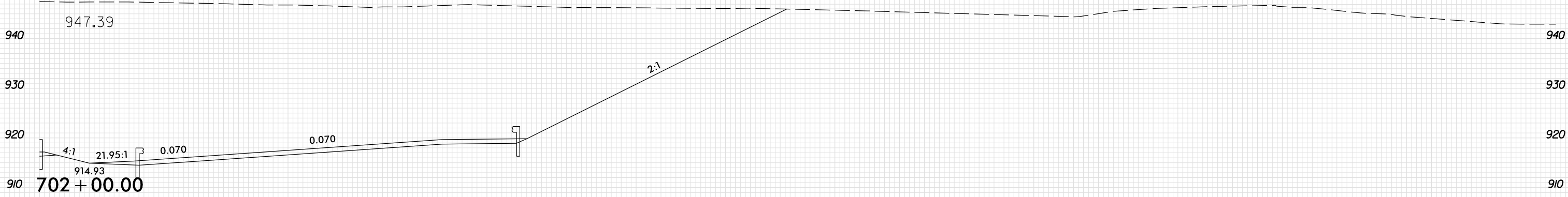
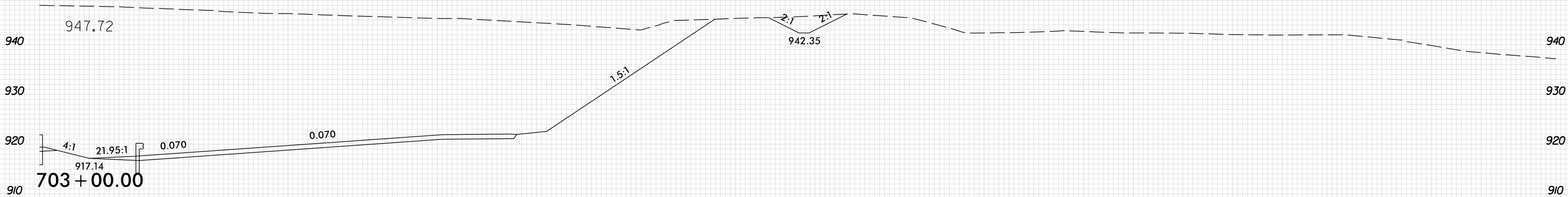

10 0 10 20 30 40 50 60 70 80 90 100 110 120 130 140 150 160 170 180 190 200 210 220 230 240 250 260 270 280 290

PLOT DRIVER: NCDOT_pdf_color_eng_100.plt
USER: SPEREIRA
DATE: 6/10/2021
TIME: 2:17:40 PM
FILE: \



8/23/99

0 5 10	PROJ. REFERENCE NO.	SHEET NO.
	U-2579AB	X-94

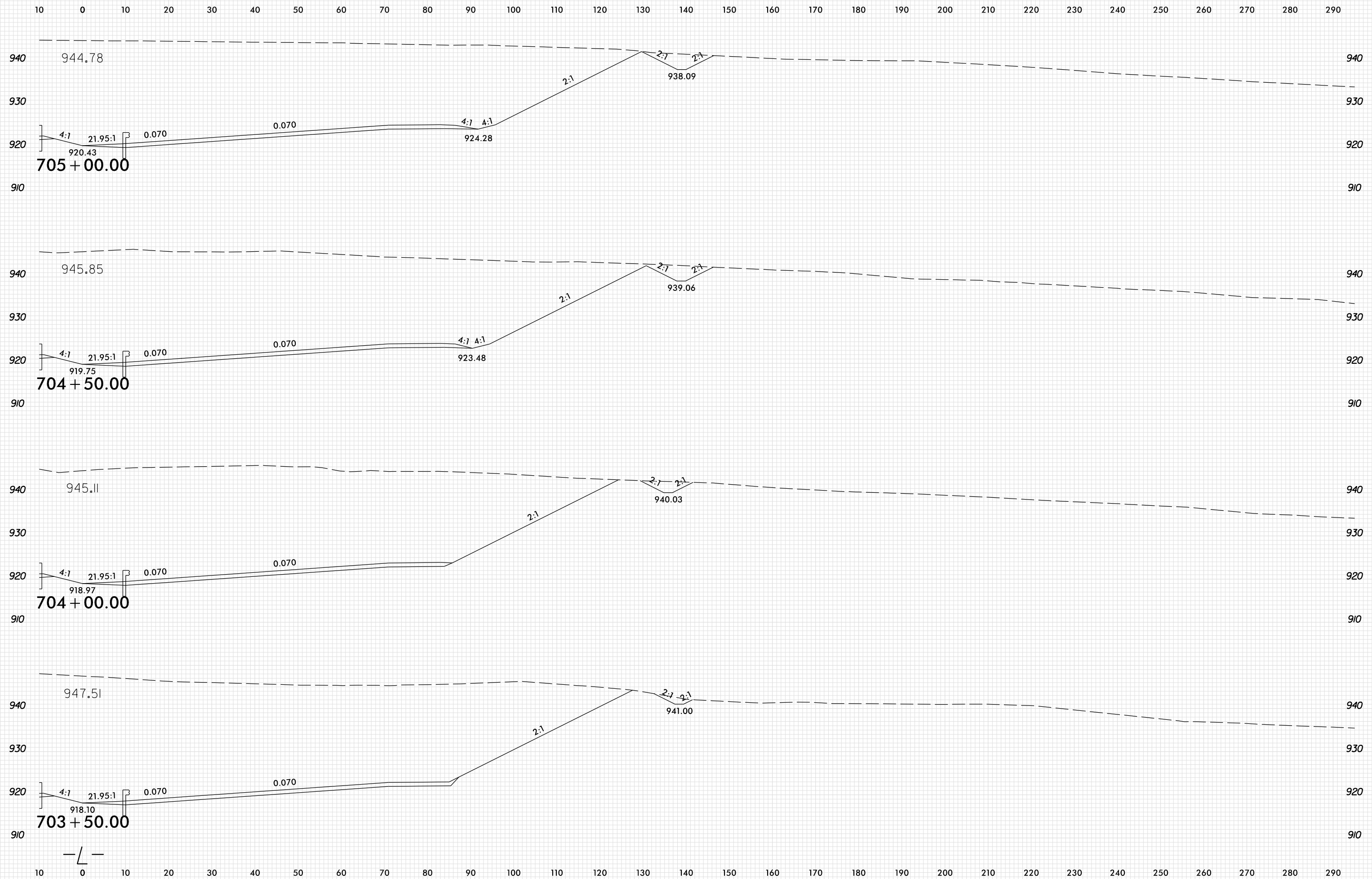

PLOT DRIVER: NCDOT_pdf_color_eng_100.plt
 USER: SPEREIRA
 DATE: 6/10/2021
 TIME: 2:17:40 PM
 FILE: \

8/23/99

10 0 10 20 30 40 50 60 70 80 90 100 110 120 130 140 150 160 170 180 190 200 210 220 230 240 250 260 270 280 290

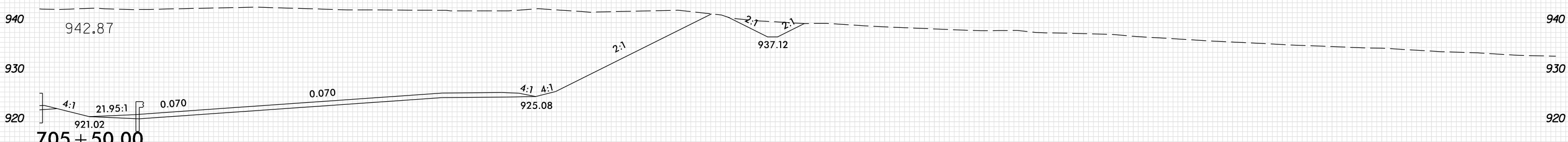
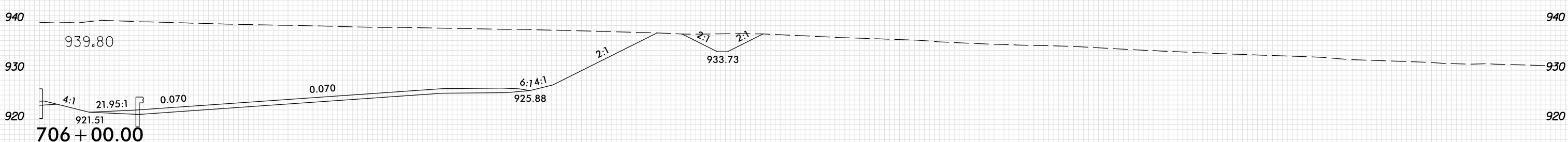
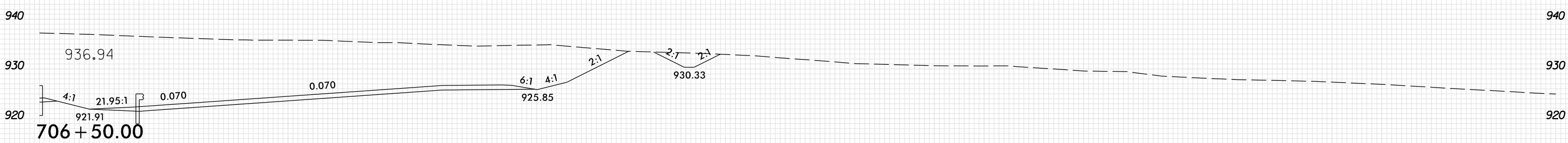
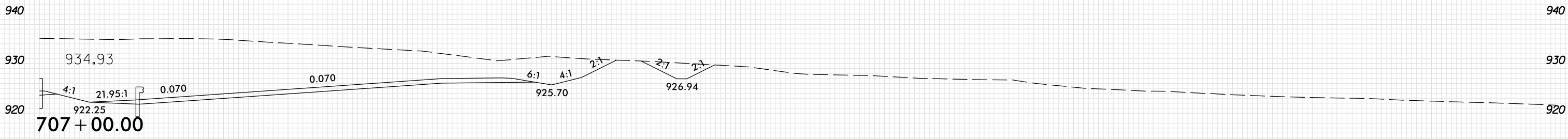

10 0 10 20 30 40 50 60 70 80 90 100 110 120 130 140 150 160 170 180 190 200 210 220 230 240 250 260 270 280 290

PLOT DRIVER: NCDOT_pdf_color_eng_100.plt
USER: SPEREIRA
DATE: 6/10/2021
TIME: 2:17:41 PM
FILE: \

8/23/99

10 0 10 20 30 40 50 60 70 80 90 100 110 120 130 140 150 160 170 180 190 200 210 220 230 240 250 260 270 280 290

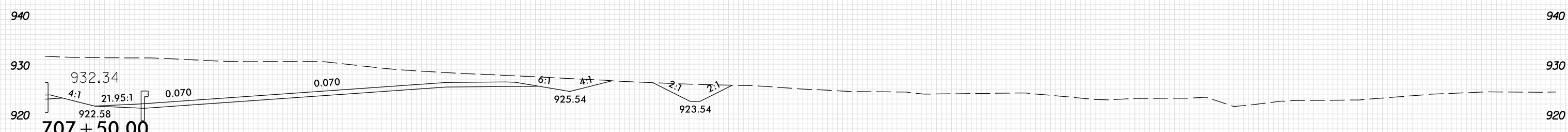
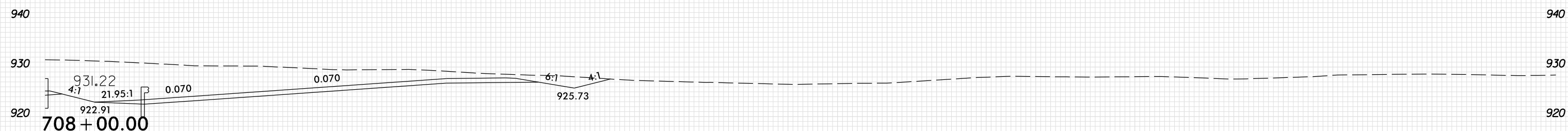
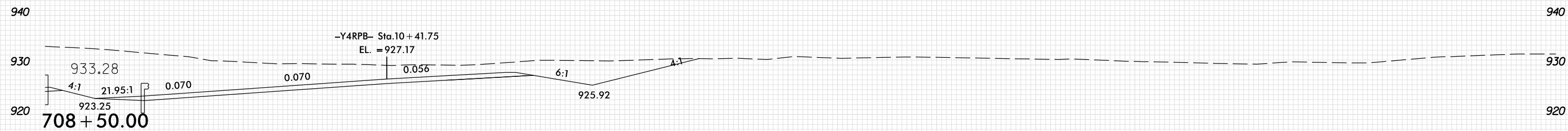
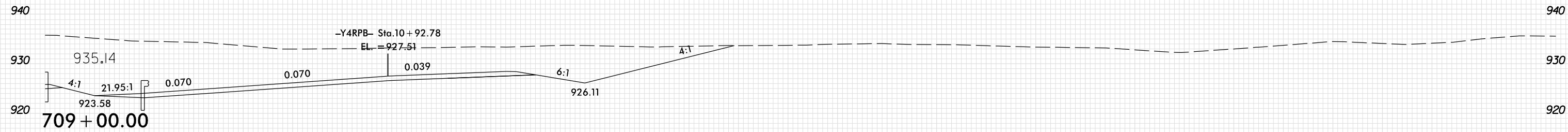

10 0 10 20 30 40 50 60 70 80 90 100 110 120 130 140 150 160 170 180 190 200 210 220 230 240 250 260 270 280 290

PLOT DRIVER: NCDOT_pdf_color_eng_100.plt
USER: SPEREIRA
DATE: 6/10/2021
TIME: 2:17:42 PM
FILE: \

8/23/99

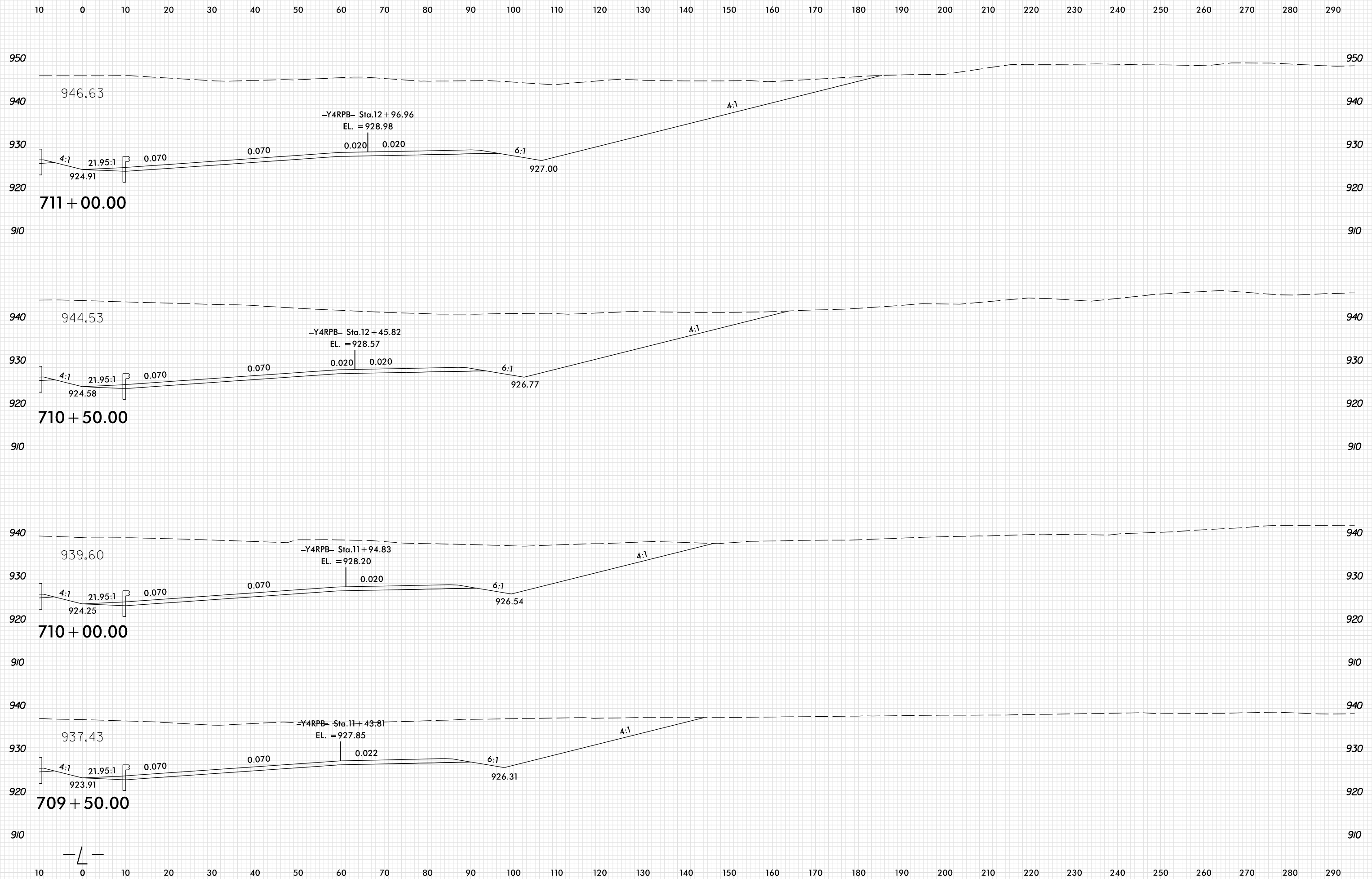

PLOT DRIVER: NCDOT_pdf_color_eng_100.plt
 USER: SPEREIRA
 DATE: 6/10/2021
 TIME: 2:17:42 PM
 FILE: \

8/23/99

10 0 10 20 30 40 50 60 70 80 90 100 110 120 130 140 150 160 170 180 190 200 210 220 230 240 250 260 270 280 290

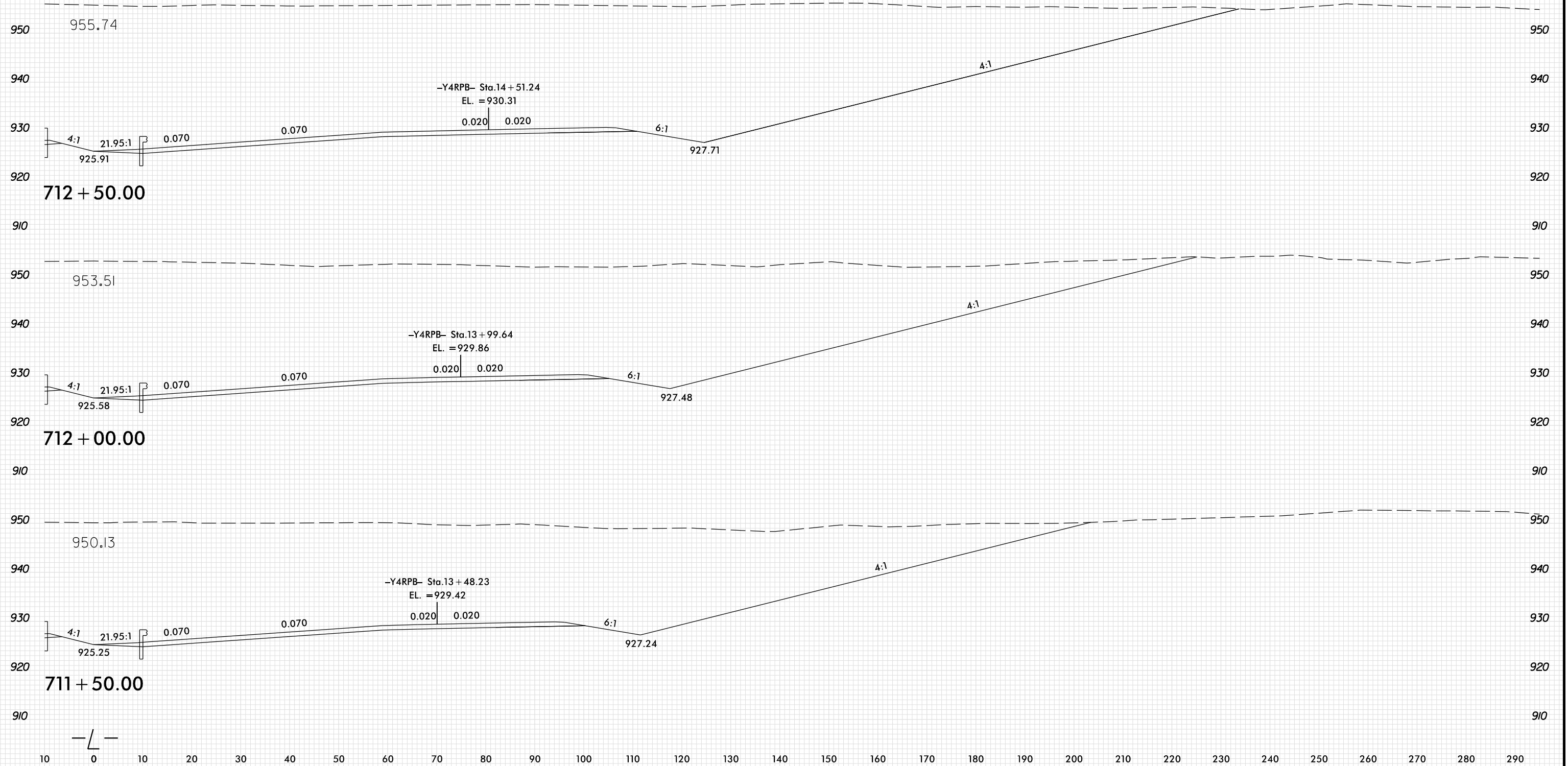

PLOT DRIVER: NCDOT_pdf_color_eng_100.plt
USER: SPEREIRA
DATE: 6/10/2021
TIME: 2:17:43 PM
FILE: \

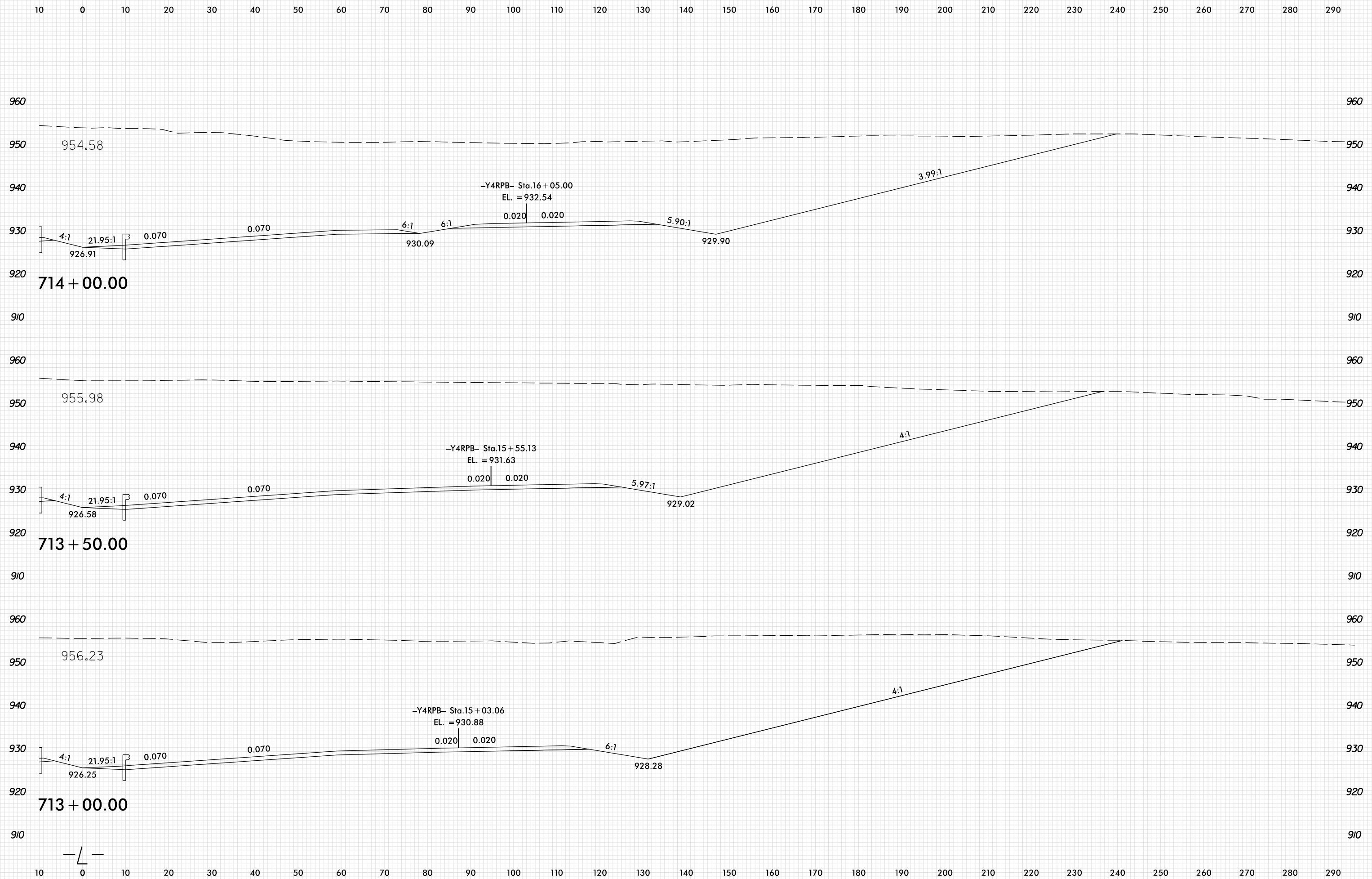

8/23/99

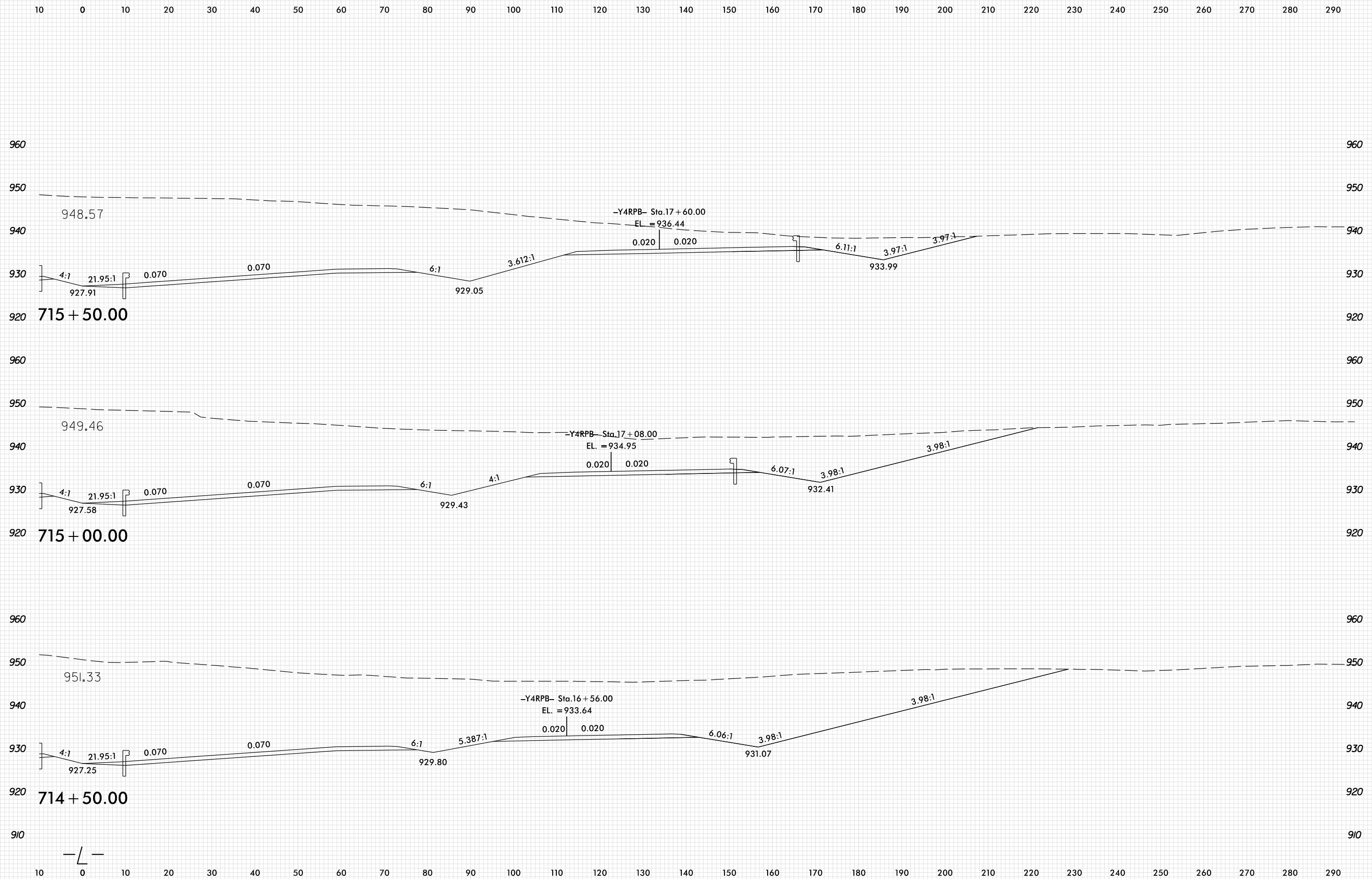

PLOT DRIVER: NCDOT_pdf_color_eng_100.plt
 USER: SPEREIRA
 DATE: 6/10/2021
 TIME: 2:17:44 PM
 FILE: \

8/23/99

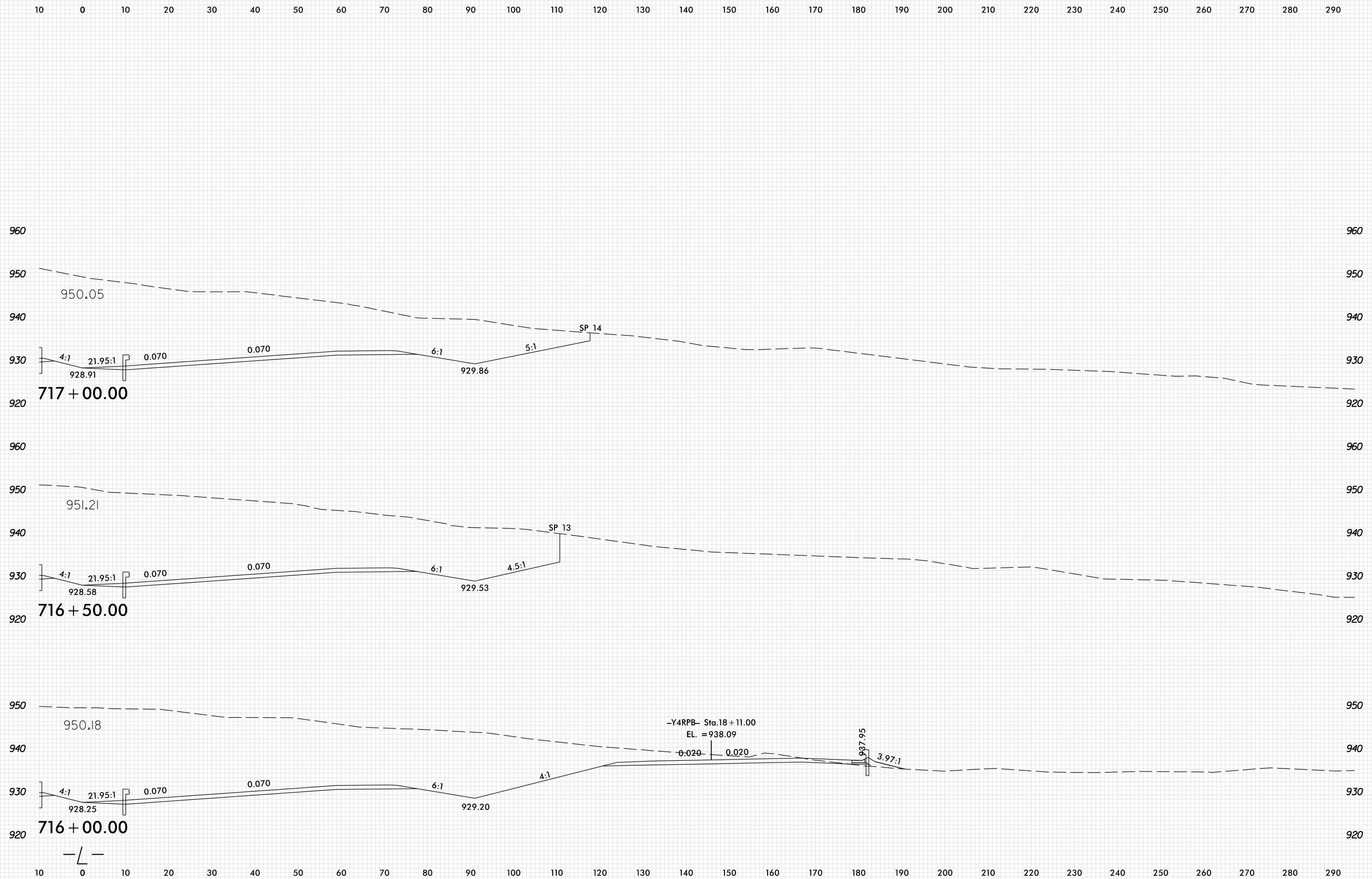

PLOT DRIVER: NCDOT_pdf_color_eng_100.plt
 USER: SPEREIRA
 DATE: 6/10/2021
 TIME: 2:17:45 PM
 FILE: \

10 0 10 20 30 40 50 60 70 80 90 100 110 120 130 140 150 160 170 180 190 200 210 220 230 240 250 260 270 280 290

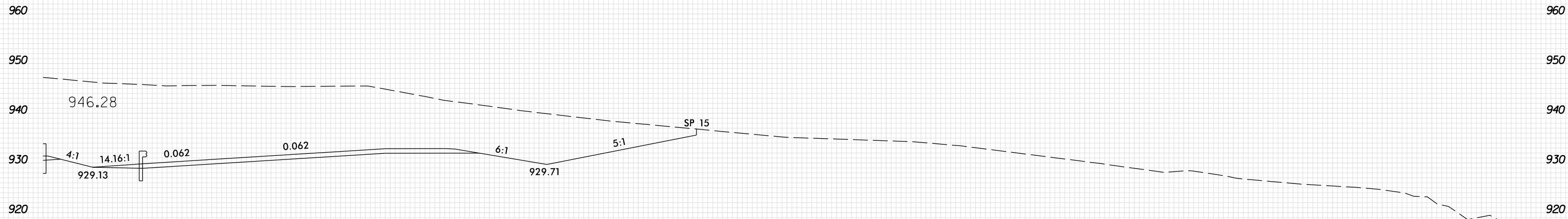
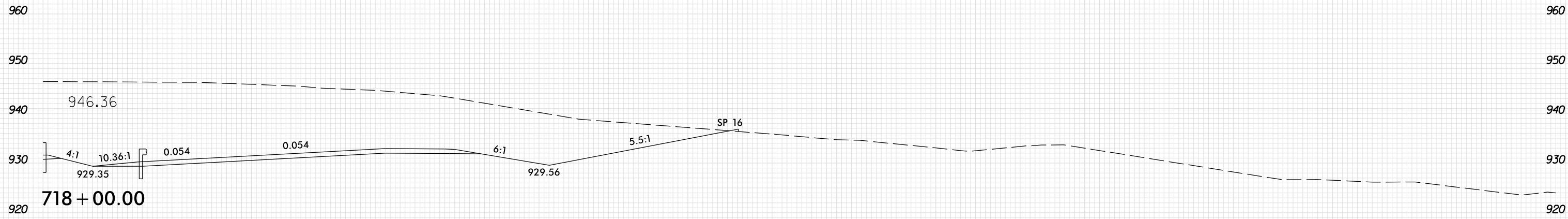
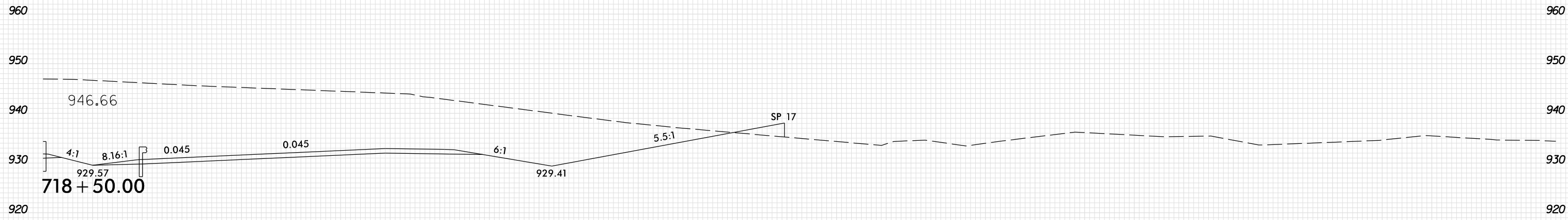

10 0 10 20 30 40 50 60 70 80 90 100 110 120 130 140 150 160 170 180 190 200 210 220 230 240 250 260 270 280 290

8/23/99

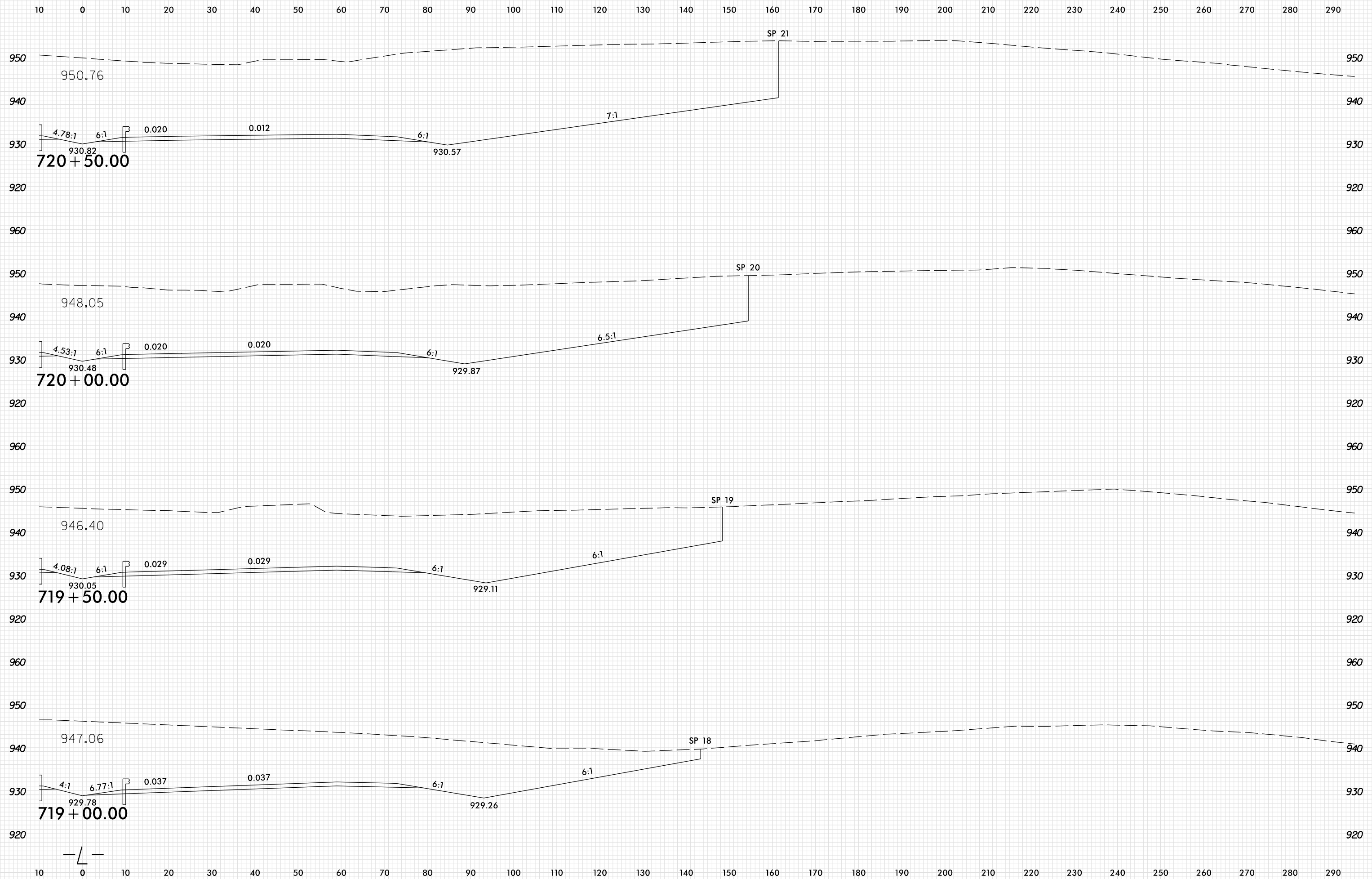

PLOT DRIVER: NCD01_pdf_color_eng_100.plt
 USER: SPEREIRA
 DATE: 6/10/2021
 TIME: 2:17:46 PM
 FILE: \

8/23/99

0 5 10	PROJ. REFERENCE NO.	SHEET NO.
	U-2579AB	X-104

10 0 10 20 30 40 50 60 70 80 90 100 110 120 130 140 150 160 170 180 190 200 210 220 230 240 250 260 270 280 290

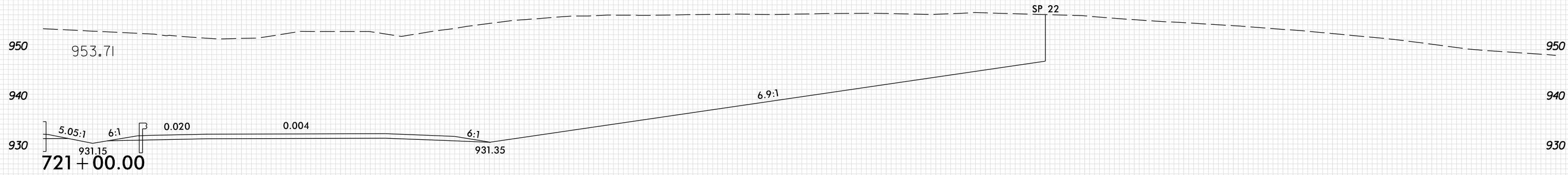
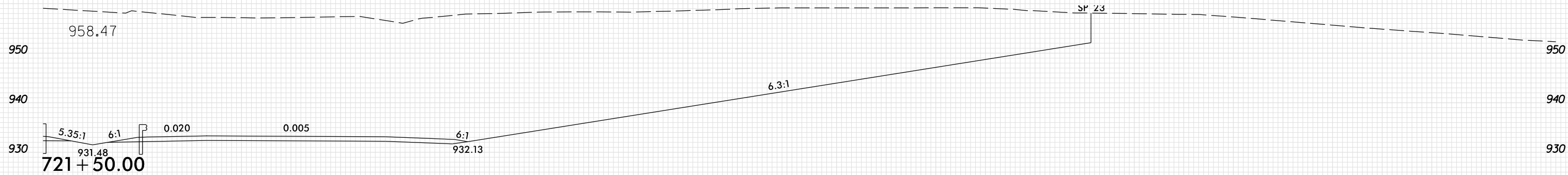
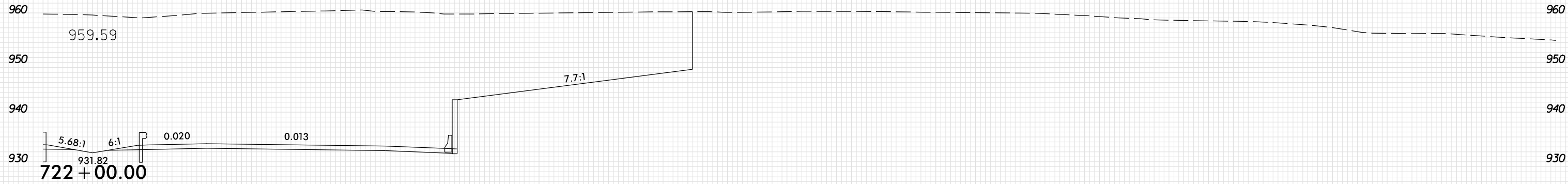

10 0 10 20 30 40 50 60 70 80 90 100 110 120 130 140 150 160 170 180 190 200 210 220 230 240 250 260 270 280 290

PLOT DRIVER: NCDOT_pdf_color_eng_100.plt
 USER: SPEREIRA
 DATE: 6/10/2021
 TIME: 2:17:46 PM
 FILE: \

8/23/99

10 0 10 20 30 40 50 60 70 80 90 100 110 120 130 140 150 160 170 180 190 200 210 220 230 240 250 260 270 280 290

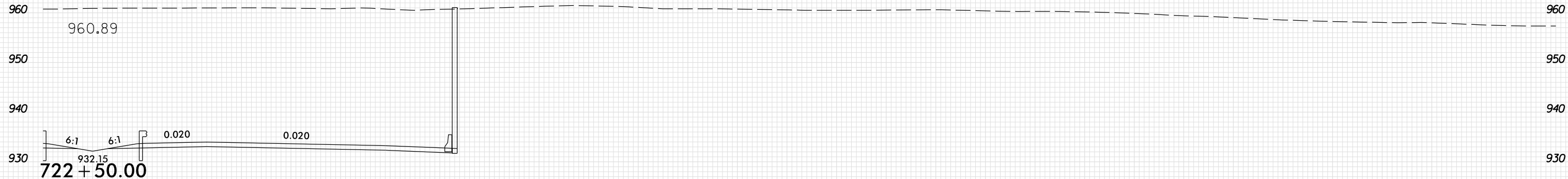
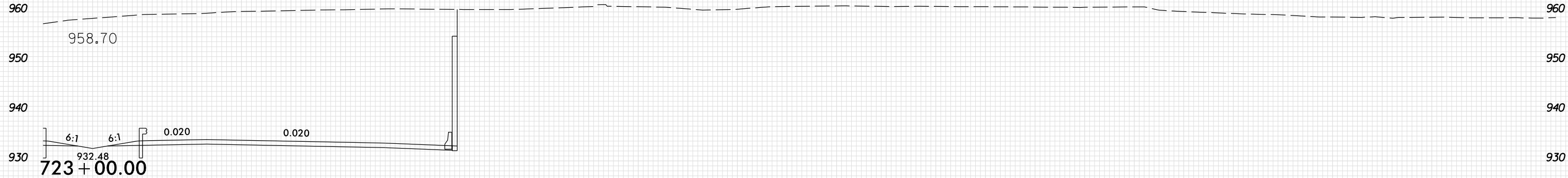
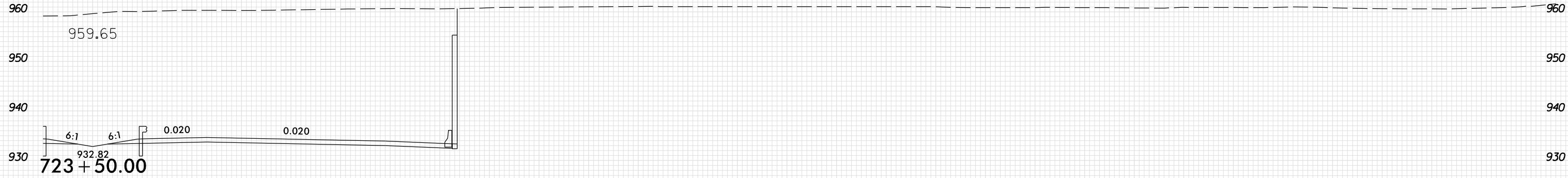

10 0 10 20 30 40 50 60 70 80 90 100 110 120 130 140 150 160 170 180 190 200 210 220 230 240 250 260 270 280 290

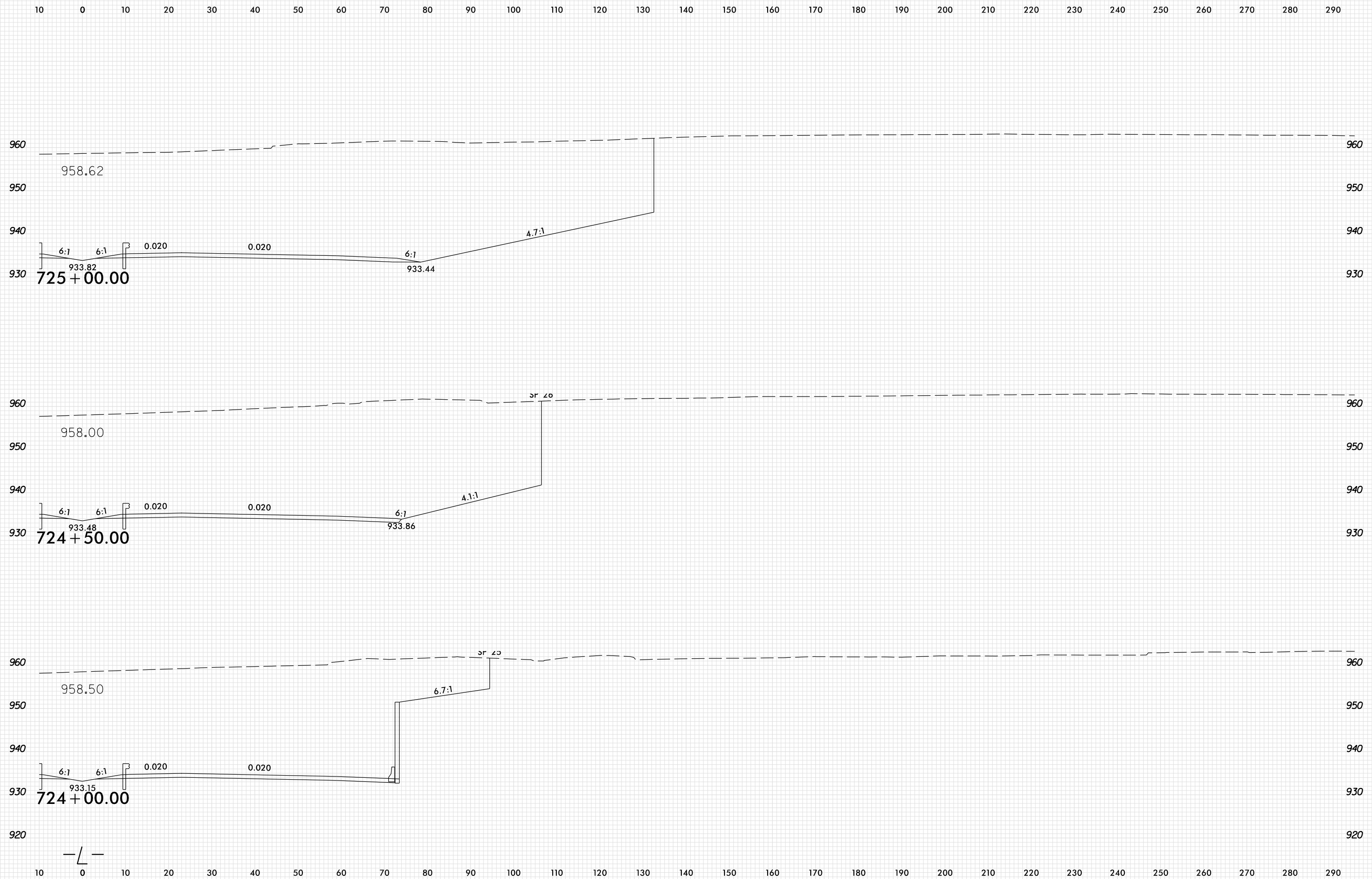

8/23/99

10 0 10 20 30 40 50 60 70 80 90 100 110 120 130 140 150 160 170 180 190 200 210 220 230 240 250 260 270 280 290

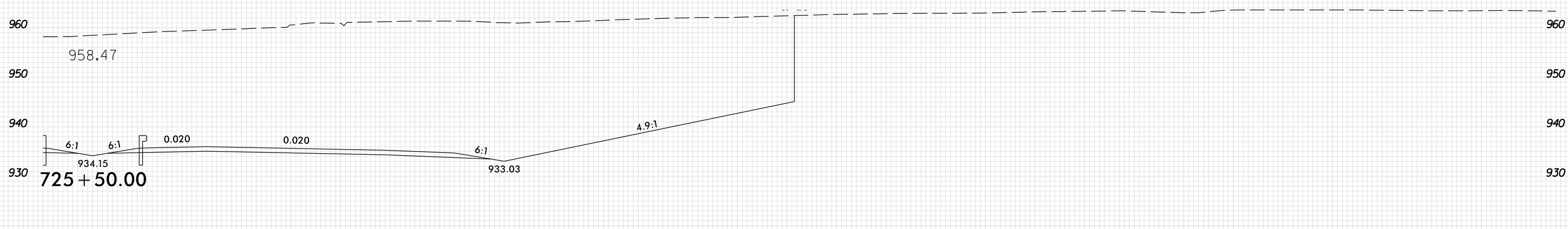
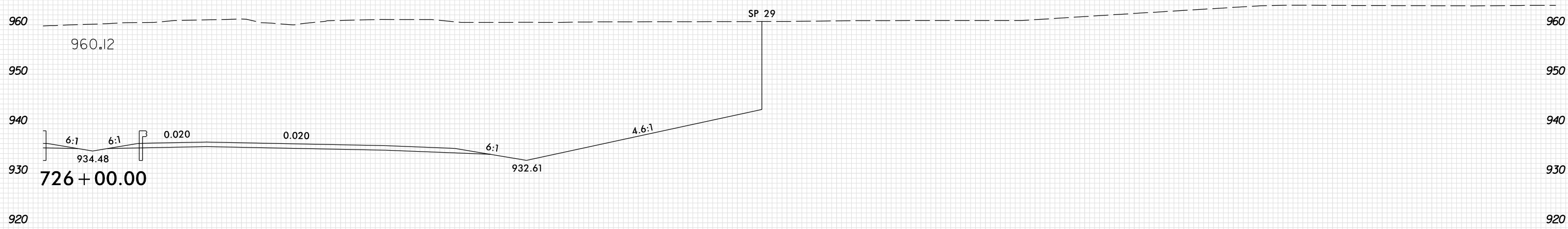
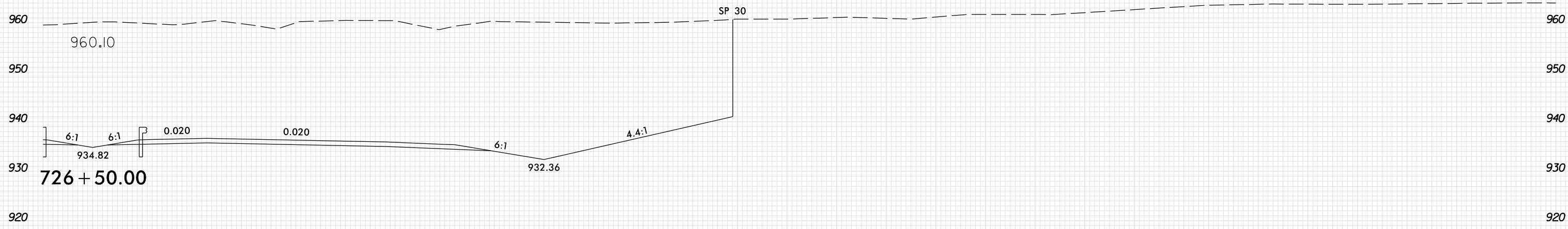

10 0 10 20 30 40 50 60 70 80 90 100 110 120 130 140 150 160 170 180 190 200 210 220 230 240 250 260 270 280 290

PLOT DRIVER: NCDOT_pdf_color_eng_100.plt
USER: SPEREIRA
DATE: 6/10/2021
TIME: 2:17:48 PM
FILE: \



8/23/99

0 5 10	PROJ. REFERENCE NO.	SHEET NO.
	U-2579AB	X-108

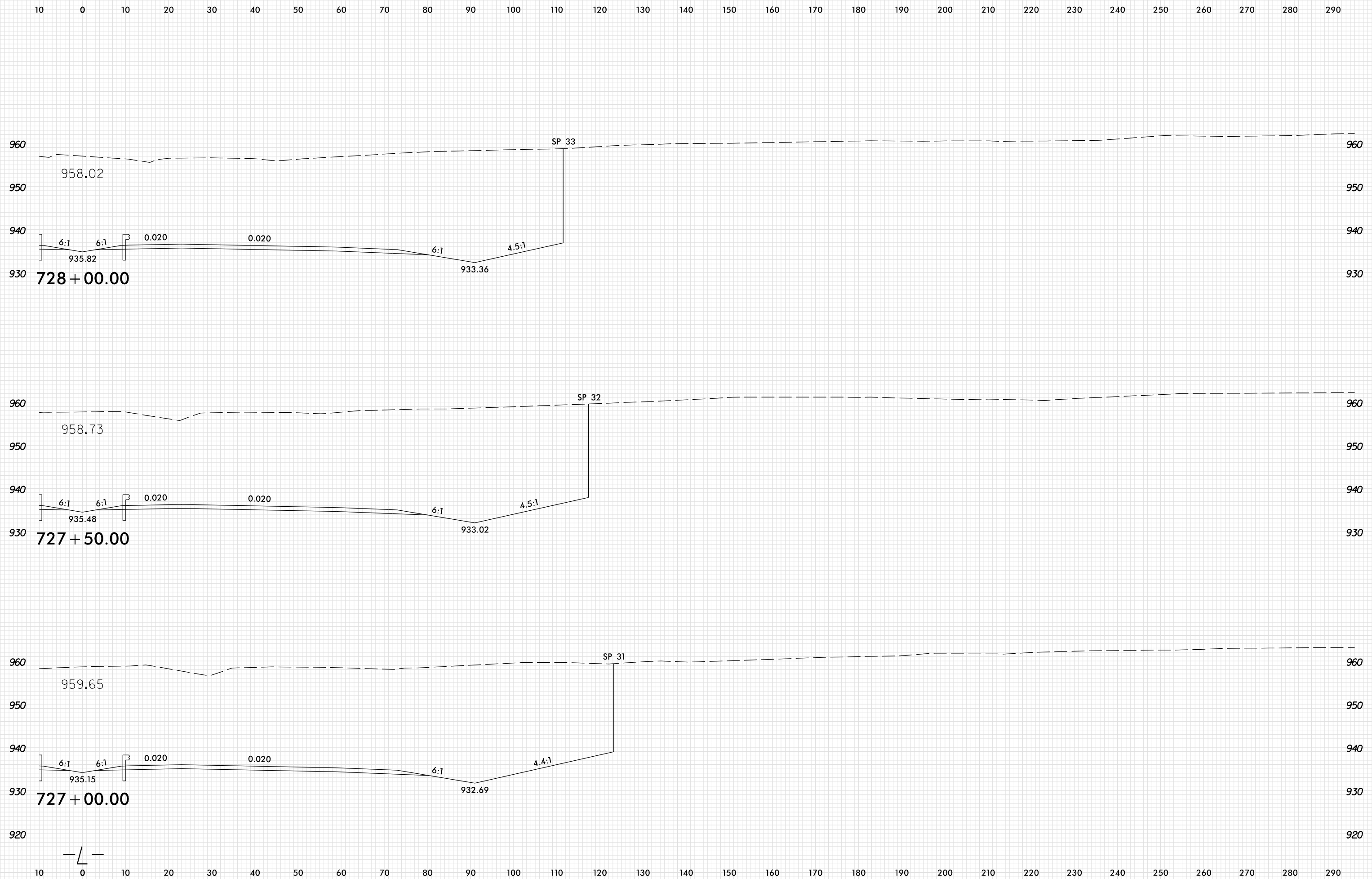

PLOT DRIVER: NCDOT_pdf_color_eng_100.plt
 USER: SPEREIRA
 DATE: 6/10/2021
 TIME: 2:17:49 PM
 FILE: \

8/23/99

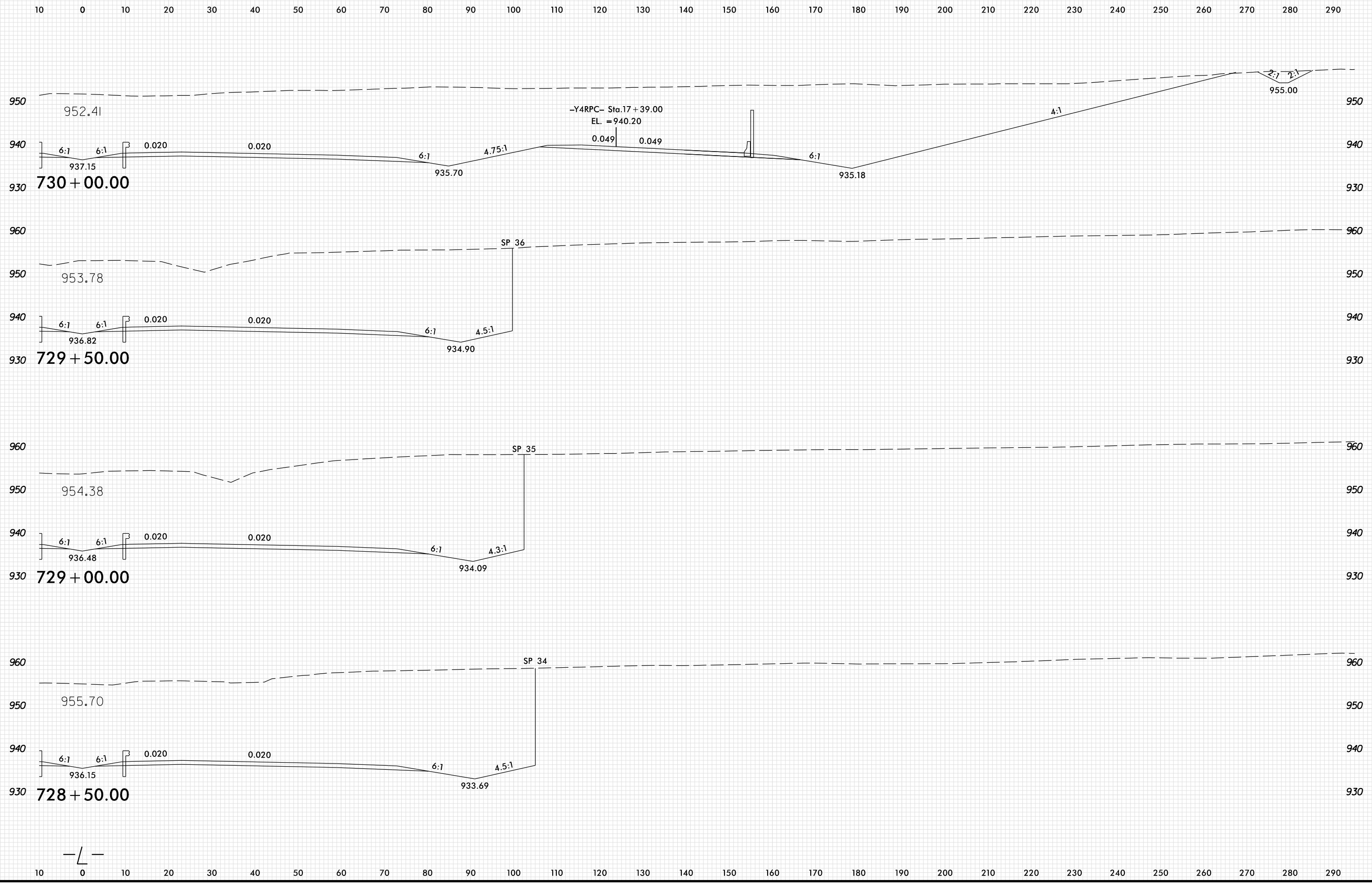

PLOT DRIVER: NCDOT_pdf_color_eng_100.plt
 USER: SPEREIRA
 DATE: 6/10/2021
 TIME: 2:17:49 PM
 FILE: \

— / —

8/23/99

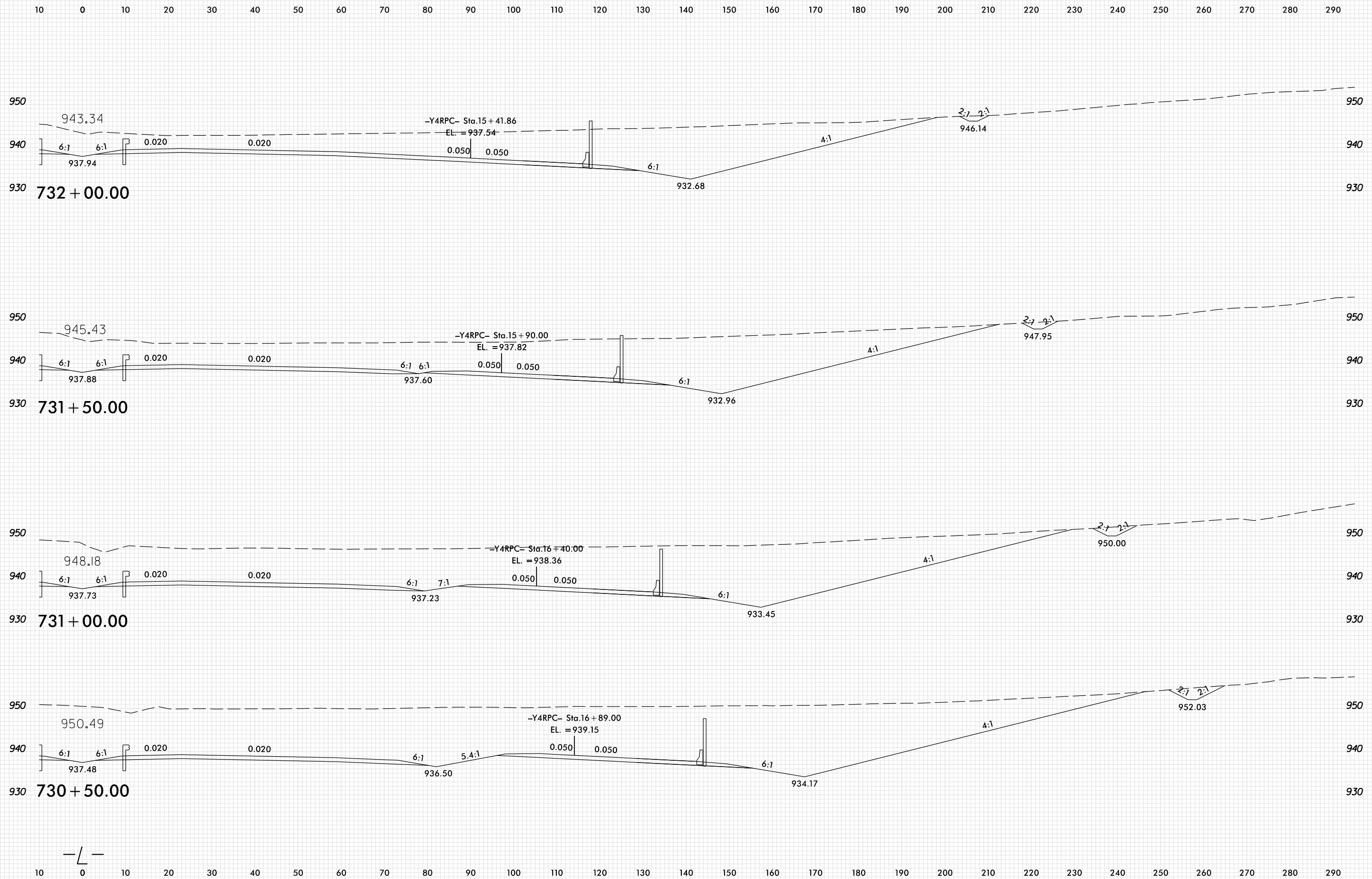

PLOT DRIVER: NCDOT_pdf_color_eng_100.plt
 USER: SPEREIRA
 DATE: 6/10/2021
 TIME: 2:17:50 PM
 FILE: \

8/23/99

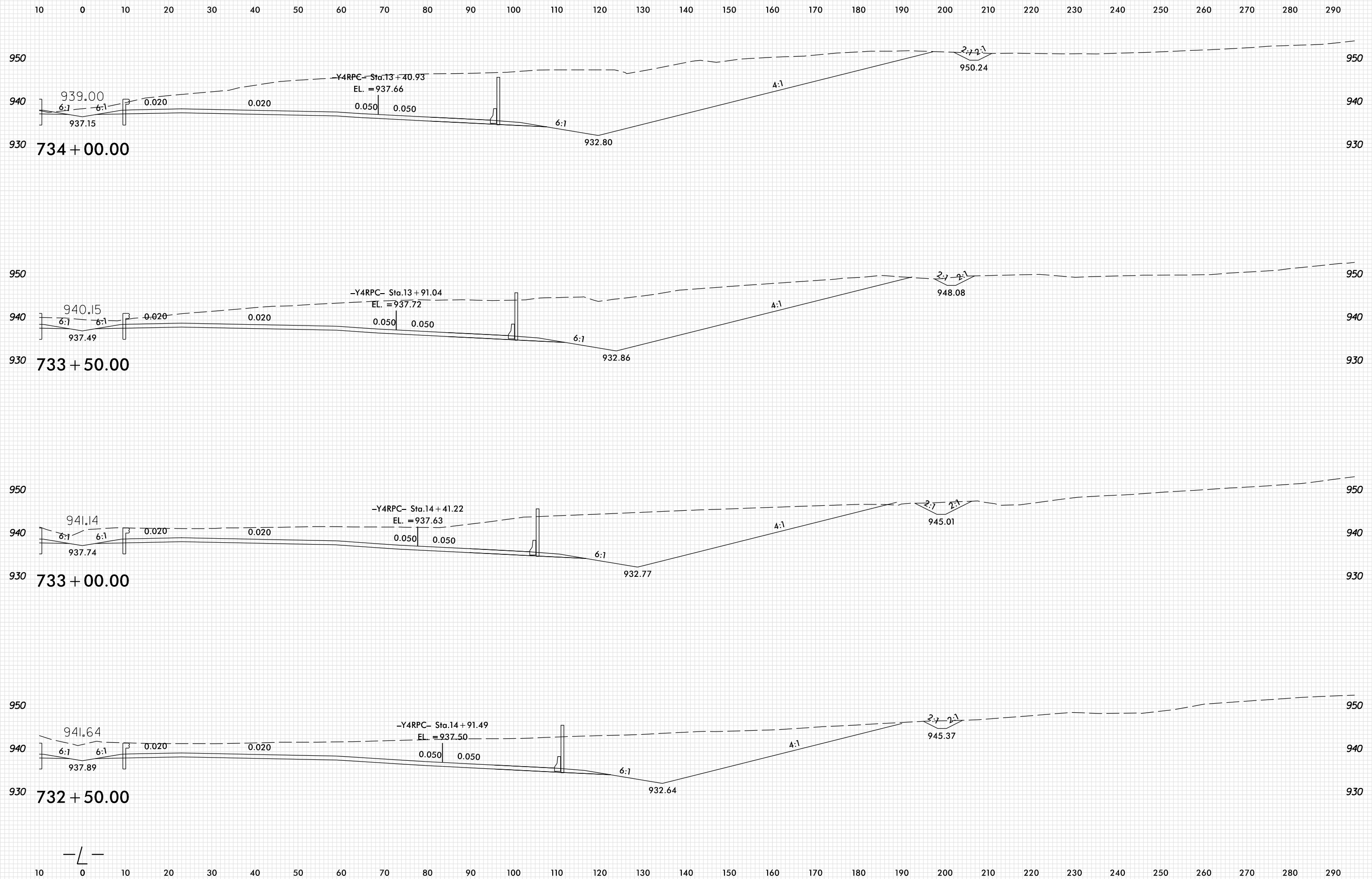

PLOT DRIVER: NCDOT_pdf_color_eng_100.plt
 USER: SPEREIRA
 DATE: 6/10/2021
 TIME: 2:17:51 PM
 FILE: \

8/23/99

10 0 10 20 30 40 50 60 70 80 90 100 110 120 130 140 150 160 170 180 190 200 210 220 230 240 250 260 270 280 290

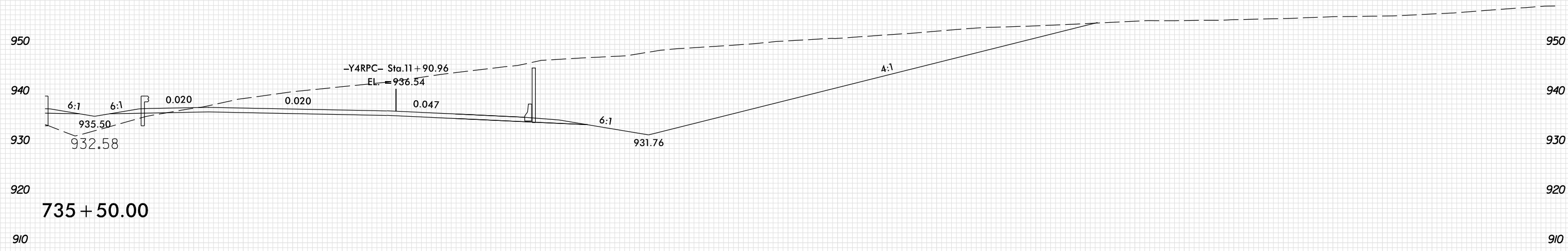

735 + 50.00

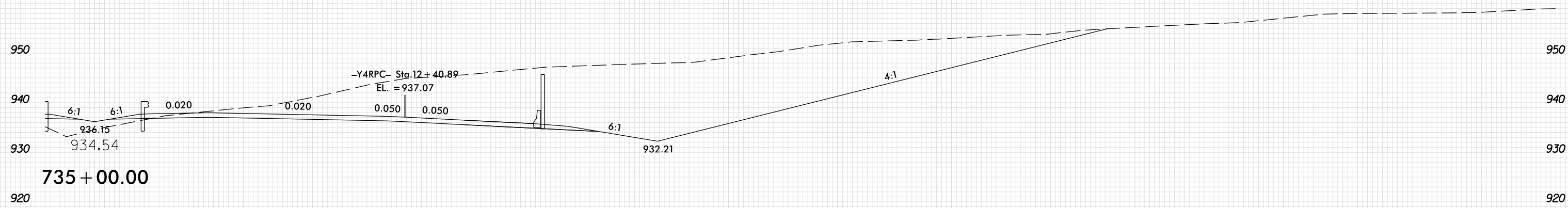

735 + 00.00

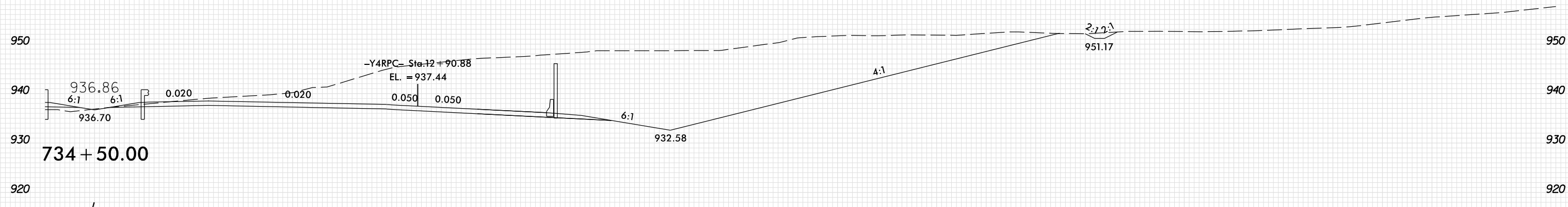

734 + 50.00

10 0 10 20 30 40 50 60 70 80 90 100 110 120 130 140 150 160 170 180 190 200 210 220 230 240 250 260 270 280 290

PLOT DRIVER: NCDOT... PENTABLE: xpl_en_v8.tbl
USER: SPEREIRA DATE: 6/10/2021 TIME: 2:17:51 PM
FILE: \

8/23/99

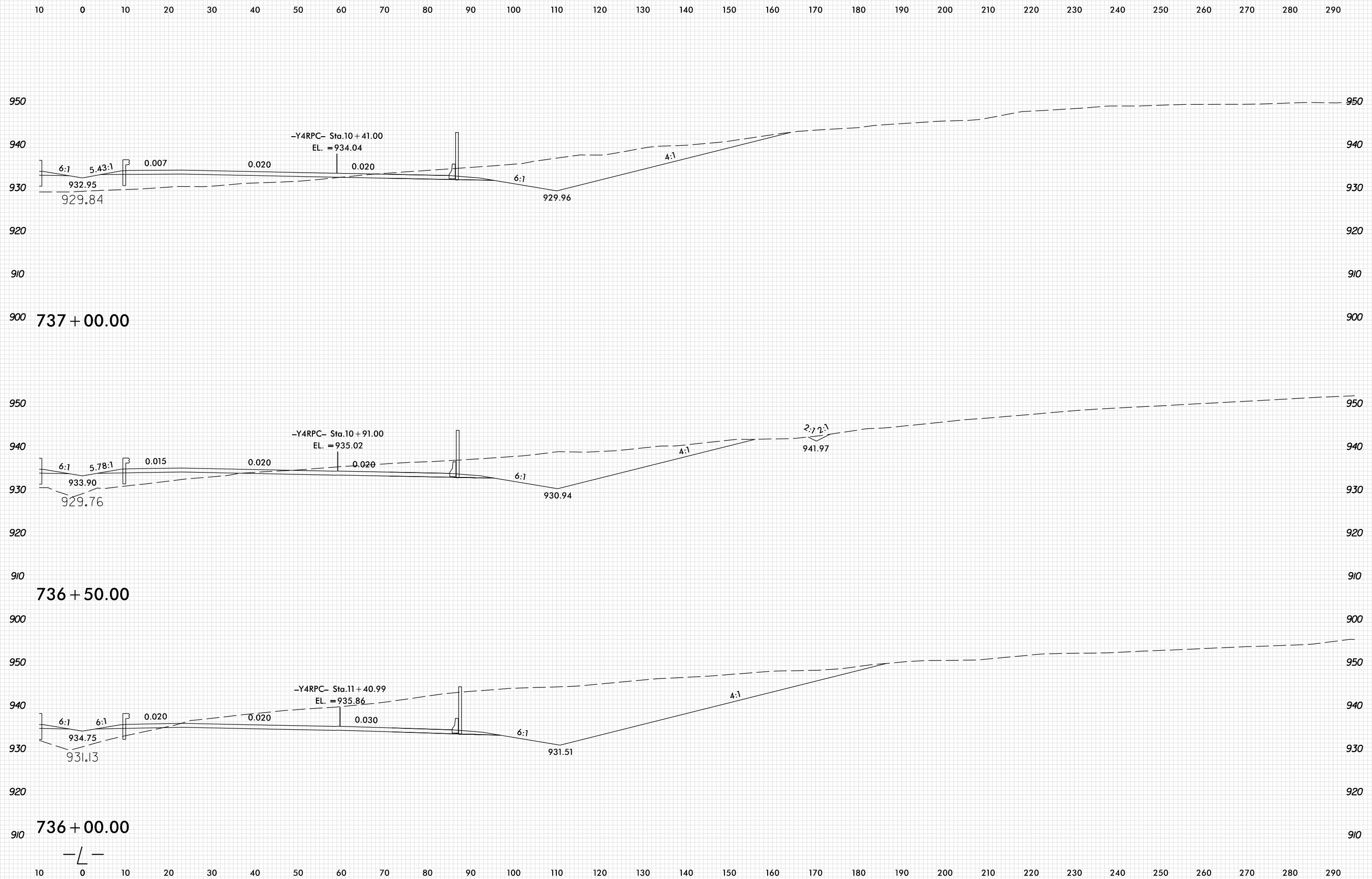

PLOT DRIVER: NCDOT_pdf_color_eng_100.plt
 USER: SPEREIRA
 DATE: 6/10/2021
 TIME: 2:17:52 PM
 FILE: \

8/23/99

0 5 10	PROJ. REFERENCE NO.	SHEET NO.
	U-2579AB	X-114

10 0 10 20 30 40 50 60 70 80 90 100 110 120 130 140 150 160 170 180 190 200 210 220 230 240 250 260 270 280 290

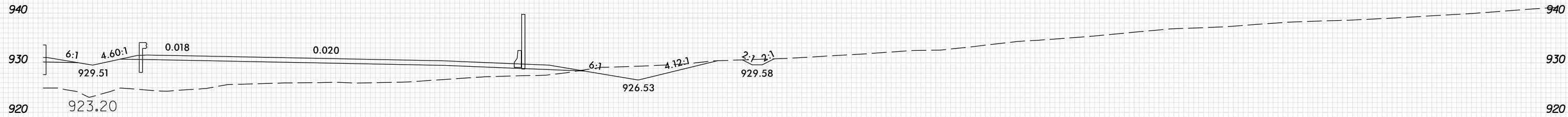

738 + 50.00

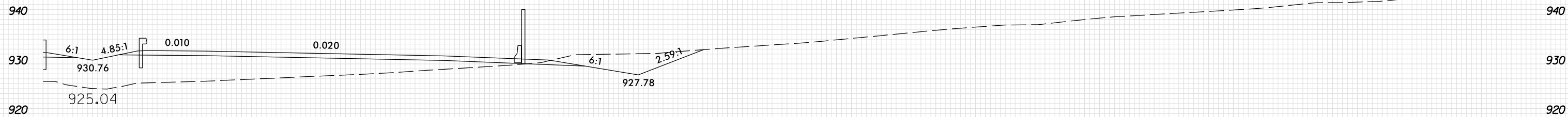

738 + 00.00

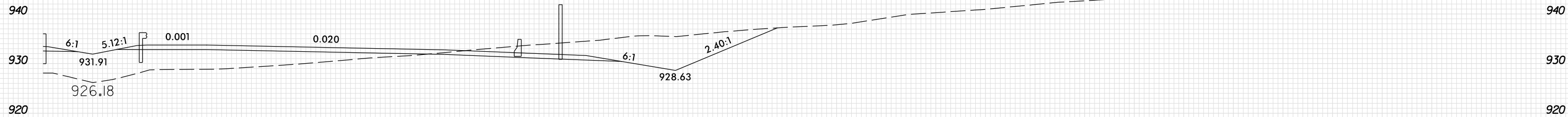

737 + 50.00

10 0 10 20 30 40 50 60 70 80 90 100 110 120 130 140 150 160 170 180 190 200 210 220 230 240 250 260 270 280 290

PLOT DRIVER: NCD01_pdf_color_eng_100.plt
 USER: SPEREIRA
 DATE: 6/10/2021
 TIME: 2:17:53 PM
 FILE: \

8/23/99

0 5 10	PROJ. REFERENCE NO.	SHEET NO.
	U-2579AB	X-115

10 0 10 20 30 40 50 60 70 80 90 100 110 120 130 140 150 160 170 180 190 200 210 220 230 240 250 260 270 280 290

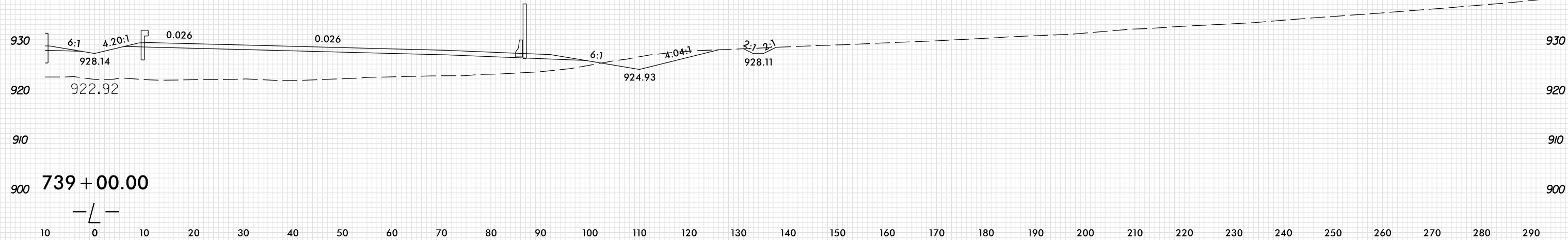
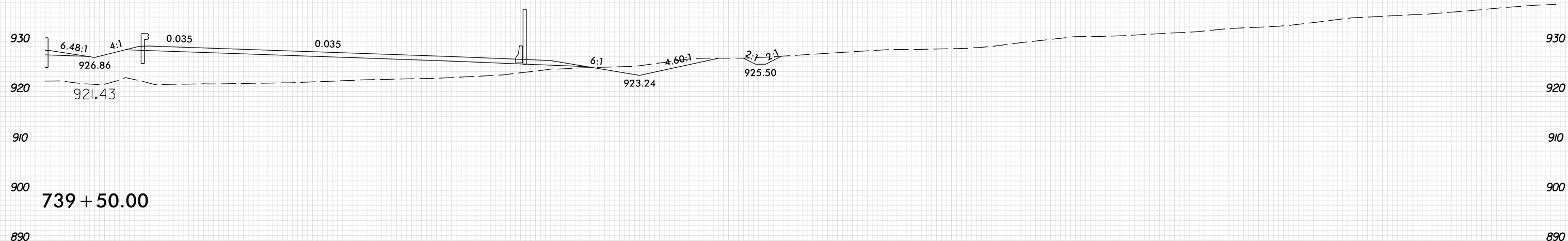
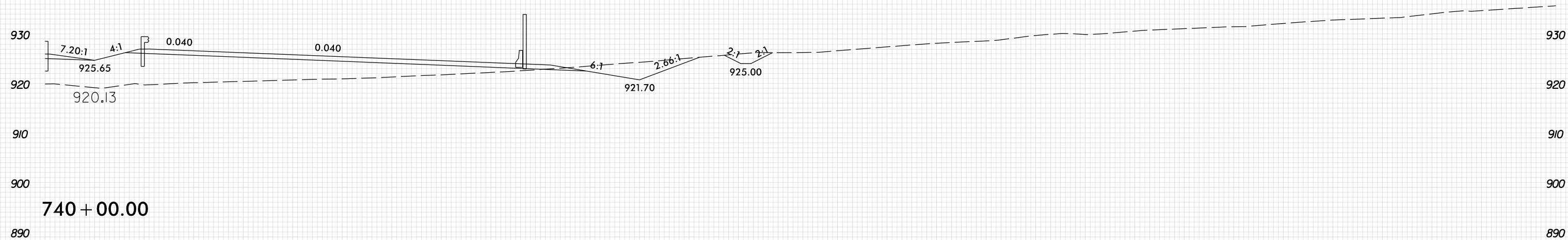

10 0 10 20 30 40 50 60 70 80 90 100 110 120 130 140 150 160 170 180 190 200 210 220 230 240 250 260 270 280 290

PLOT DRIVER: NCDOT_pdf_color_eng_100.plt
 USER: SPEREIRA
 DATE: 6/10/2021
 TIME: 2:17:53 PM
 FILE: \

8/23/99

0 5 10	PROJ. REFERENCE NO.	SHEET NO.
	U-2579AB	X-116

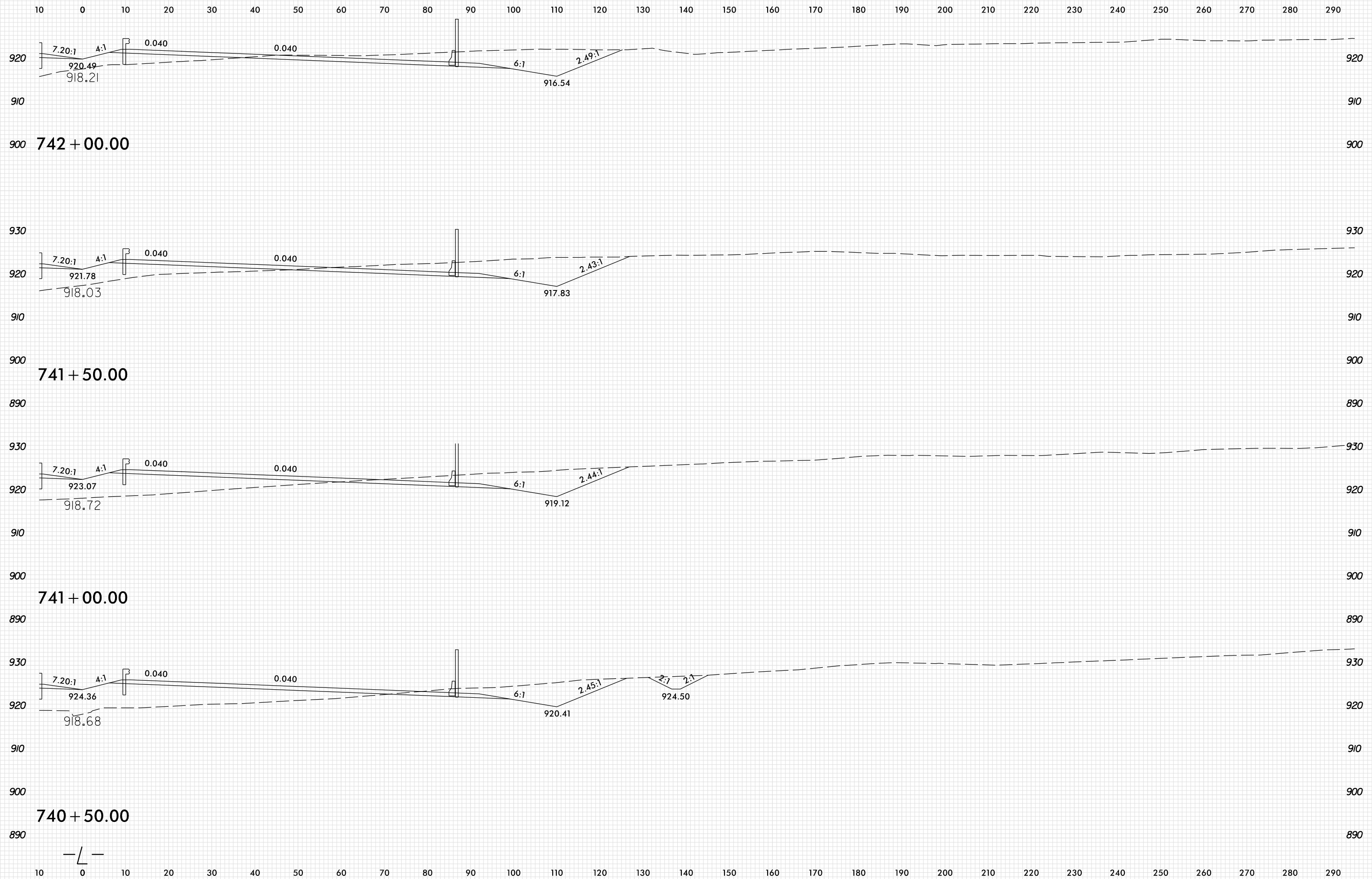

PLOT DRIVER: NCDOT_pdf_color_eng_100.plt
 USER: SPEREIRA
 DATE: 6/10/2021
 TIME: 2:17:54 PM
 FILE: \

8/23/99

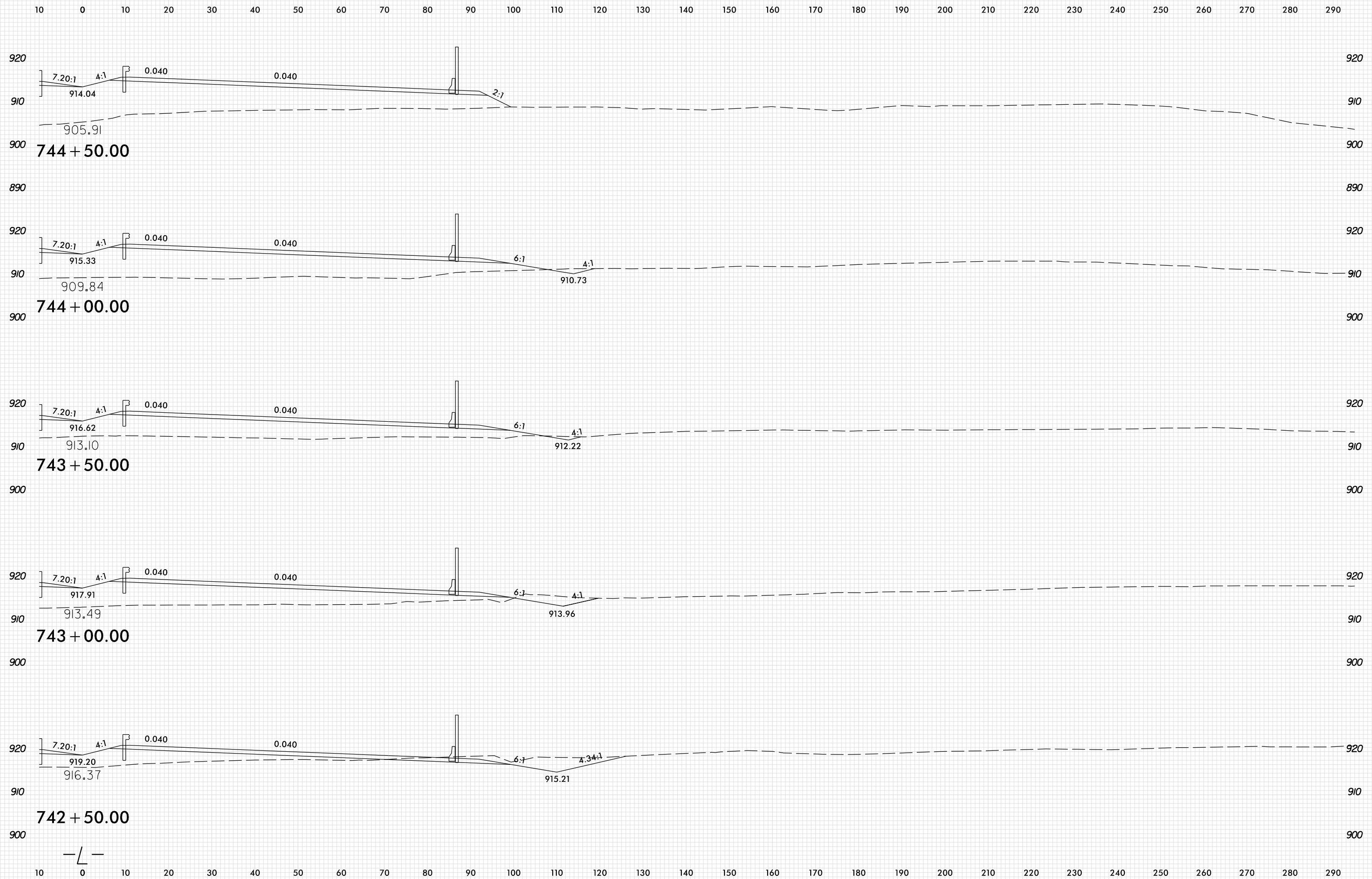

PLOT DRIVER: NCD01_pdf_color_eng_100.plt
 USER: SPEREIRA
 DATE: 6/10/2021
 TIME: 2:17:55 PM
 FILE: \

8/23/99

0 5 10	PROJ. REFERENCE NO.	SHEET NO.
	U-2579AB	X-118

10 0 10 20 30 40 50 60 70 80 90 100 110 120 130 140 150 160 170 180 190 200 210 220 230 240 250 260 270 280 290

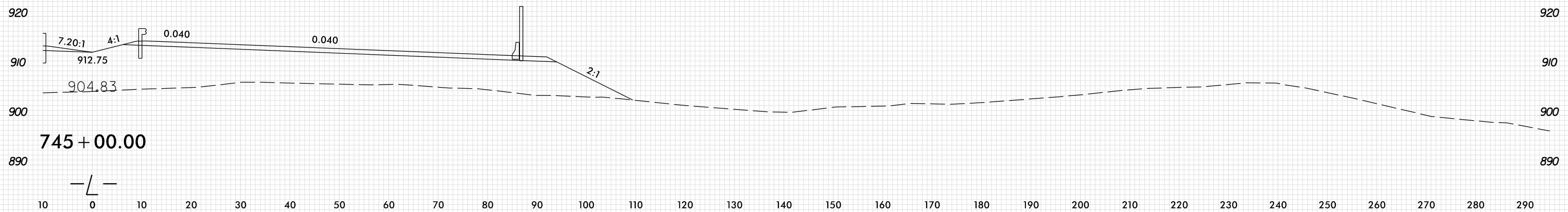
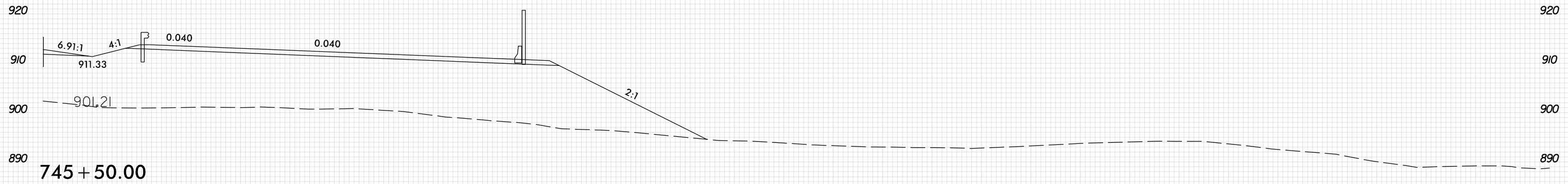

PLOT DRIVER: NCD01_pdf_color_eng_100.plt
 USER: SPEREIRA
 DATE: 6/10/2021
 TIME: 2:17:55 PM
 FILE: \

8/23/99

10 0 10 20 30 40 50 60 70 80 90 100 110 120 130 140 150 160 170 180 190 200 210 220 230 240 250 260 270 280 290

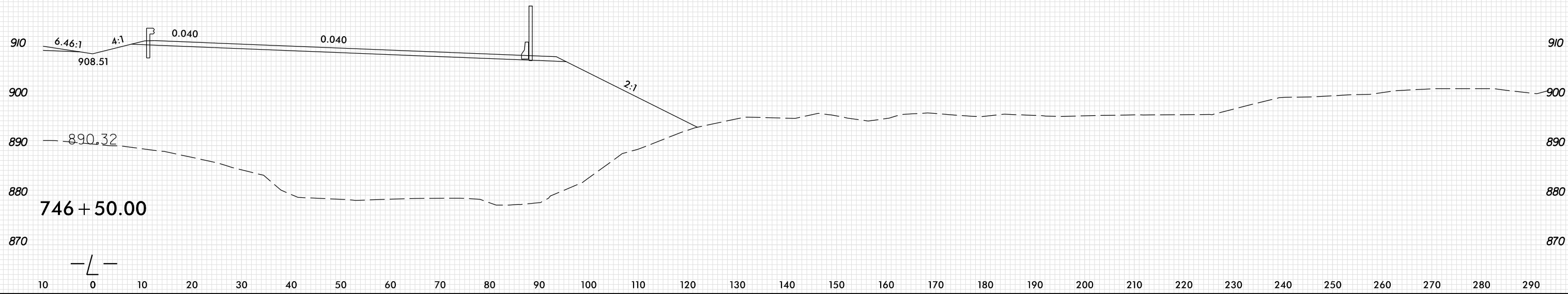
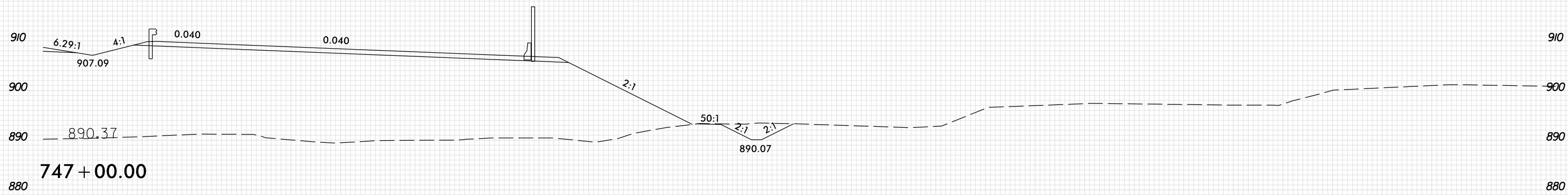
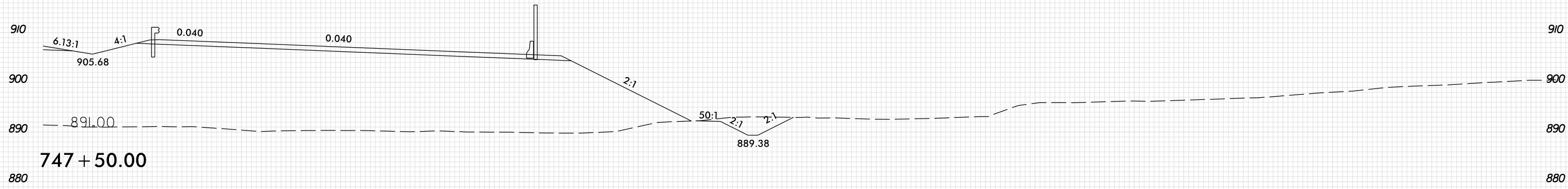

PLOT DRIVER: NCDOT_pdf_color_eng_100.plt
USER: SPEREIRA
DATE: 6/10/2021
TIME: 2:17:56 PM
FILE: \

8/23/99

0 5 10	PROJ. REFERENCE NO.	SHEET NO.
	U-2579AB	X-120

10 0 10 20 30 40 50 60 70 80 90 100 110 120 130 140 150 160 170 180 190 200 210 220 230 240 250 260 270 280 290

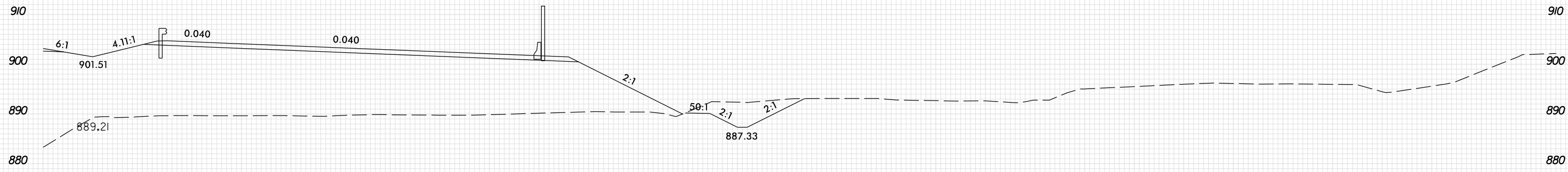

749 + 00.00

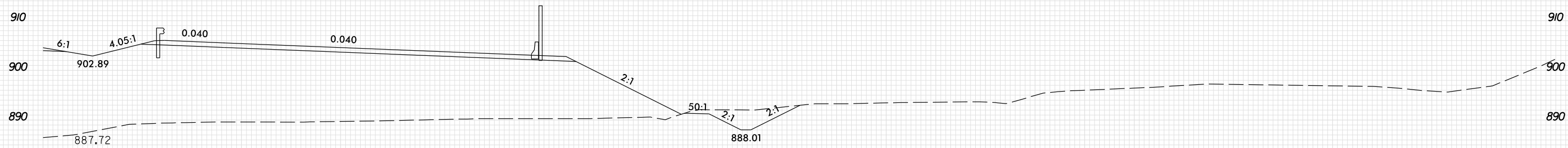

748 + 50.00

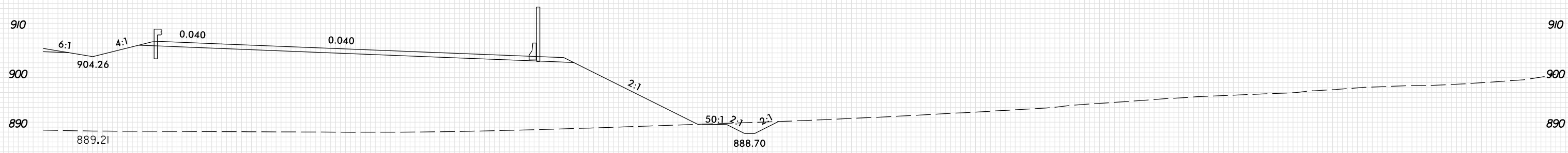

748 + 00.00

10 0 10 20 30 40 50 60 70 80 90 100 110 120 130 140 150 160 170 180 190 200 210 220 230 240 250 260 270 280 290

PLOT DRIVER: NCDOT_pdf_color_eng_100.plt
 USER: SPEREIRA
 DATE: 6/10/2021
 TIME: 2:17:57 PM
 FILE: \

8/23/99

10 0 10 20 30 40 50 60 70 80 90 100 110 120 130 140 150 160 170 180 190 200 210 220 230 240 250 260 270 280 290

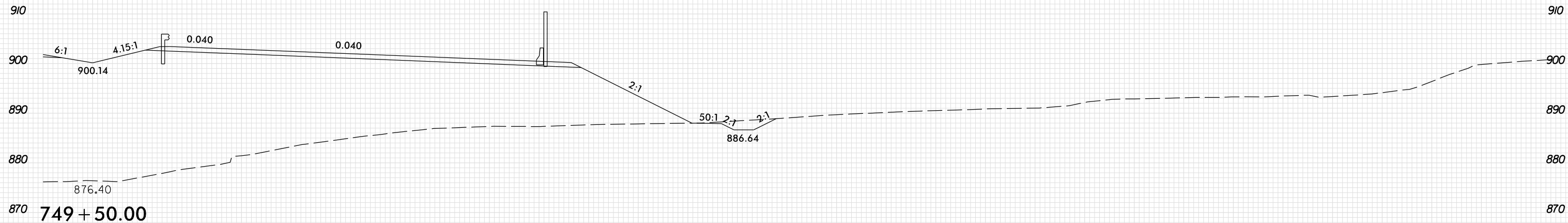
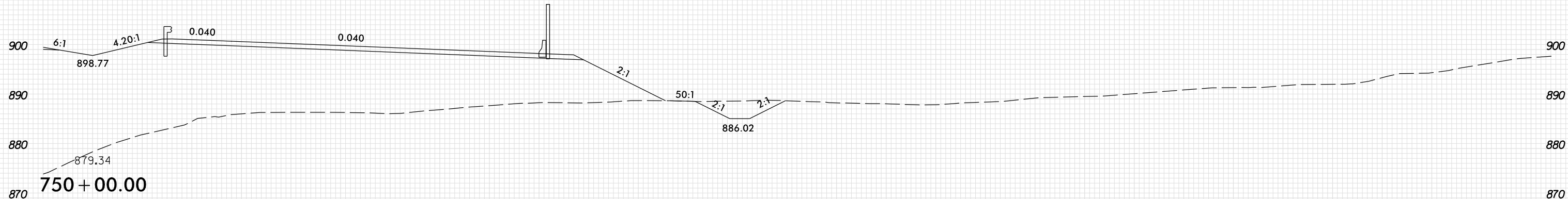
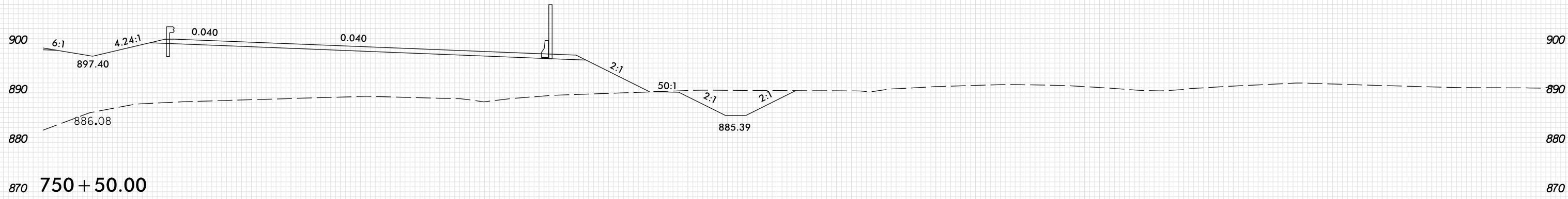

10 0 10 20 30 40 50 60 70 80 90 100 110 120 130 140 150 160 170 180 190 200 210 220 230 240 250 260 270 280 290

PLOT DRIVER: NCDOT_pdf_color_eng_100.plt
USER: SPEREIRA
DATE: 6/10/2021
TIME: 2:17:57 PM
FILE: \

10 0 10 20 30 40 50 60 70 80 90 100 110 120 130 140 150 160 170 180 190 200 210 220 230 240 250 260 270 280 290

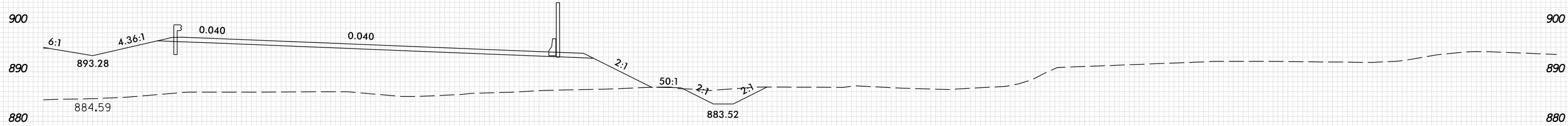

752 + 00.00

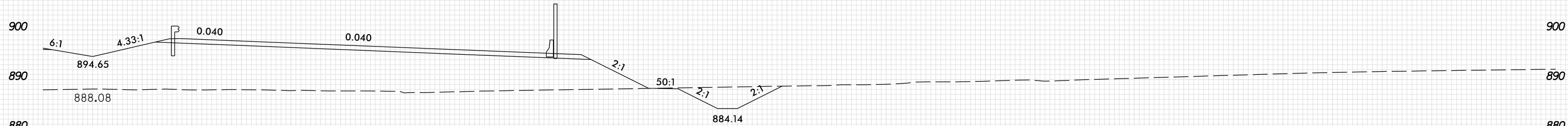

751 + 50.00

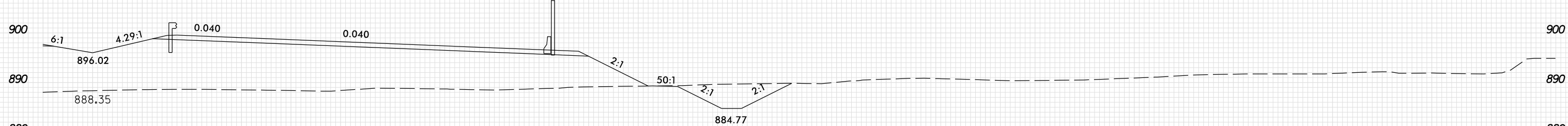

751 + 00.00

10 0 10 20 30 40 50 60 70 80 90 100 110 120 130 140 150 160 170 180 190 200 210 220 230 240 250 260 270 280 290

8/23/99

0 5 10	PROJ. REFERENCE NO.	SHEET NO.
	U-2579AB	X-123

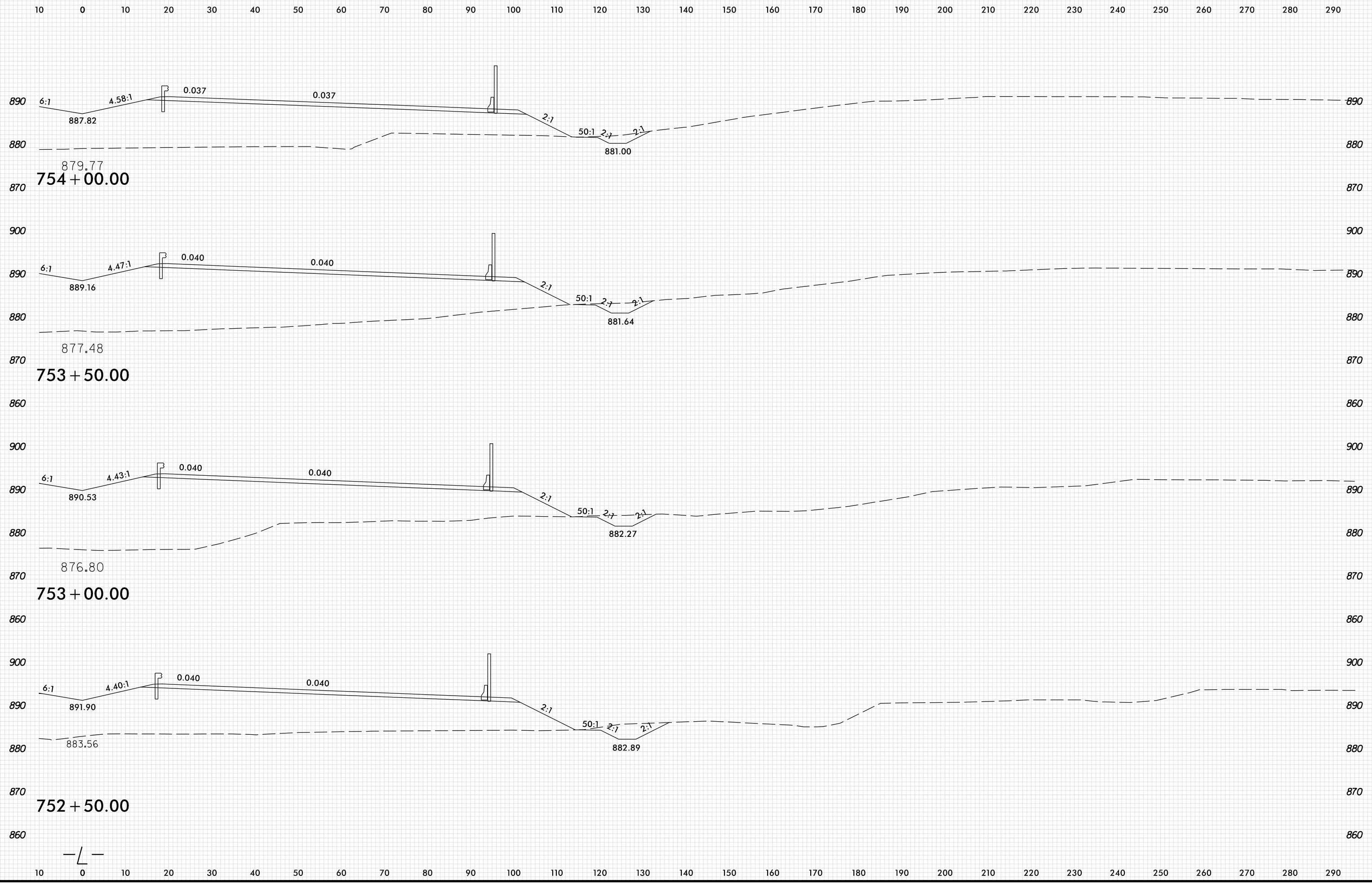

PLOT DRIVER: NCDOT_pdf_color_eng_100.plt
 USER: SPEREIRA
 DATE: 6/10/2021
 TIME: 2:17:58 PM
 FILE: \

8/23/99

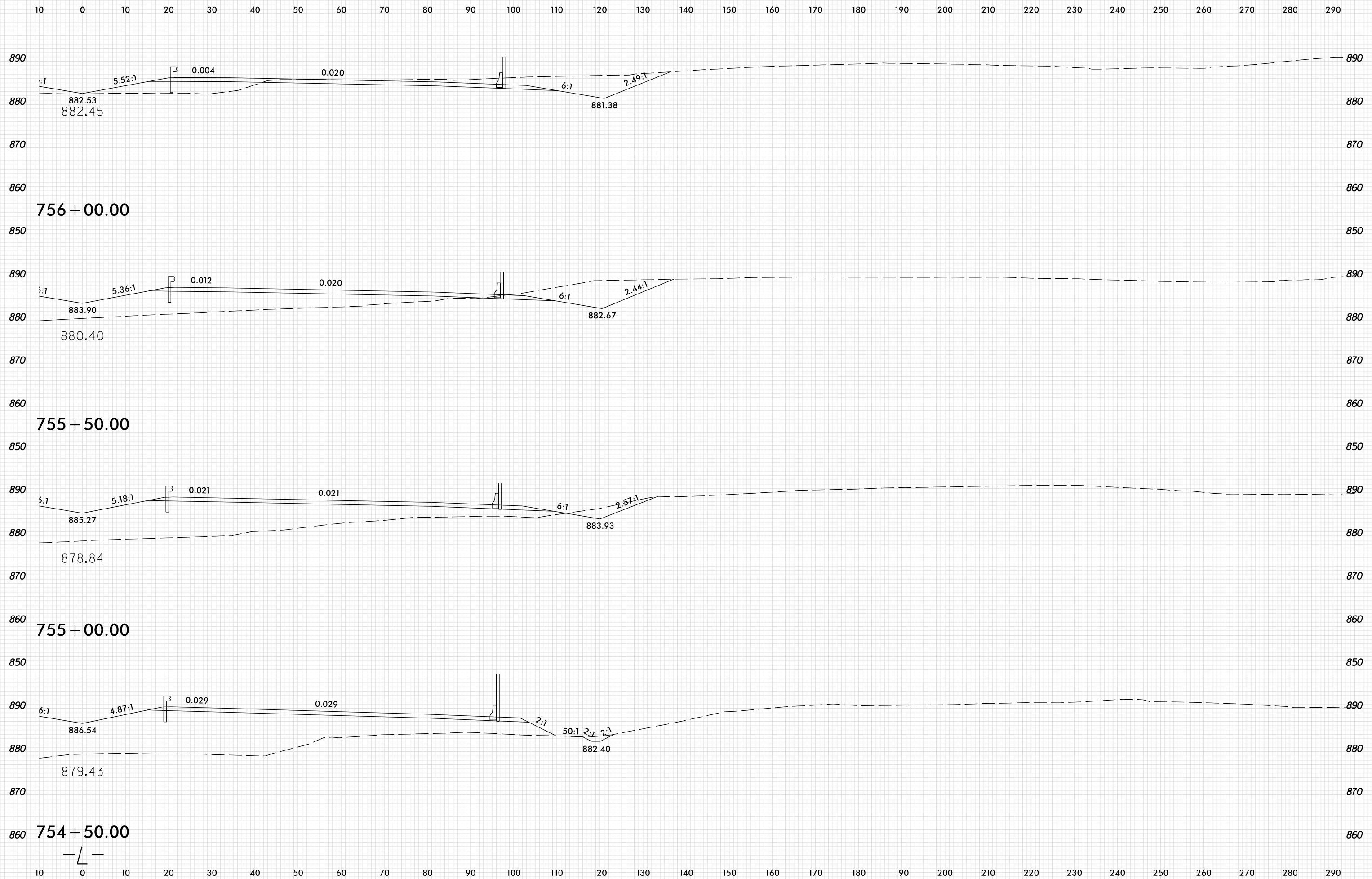

PLOT DRIVER: NCDOT_pdf_color_eng_100.plt
 USER: SPEREIRA
 DATE: 6/10/2021
 TIME: 2:17:59 PM
 FILE: \

8/23/99

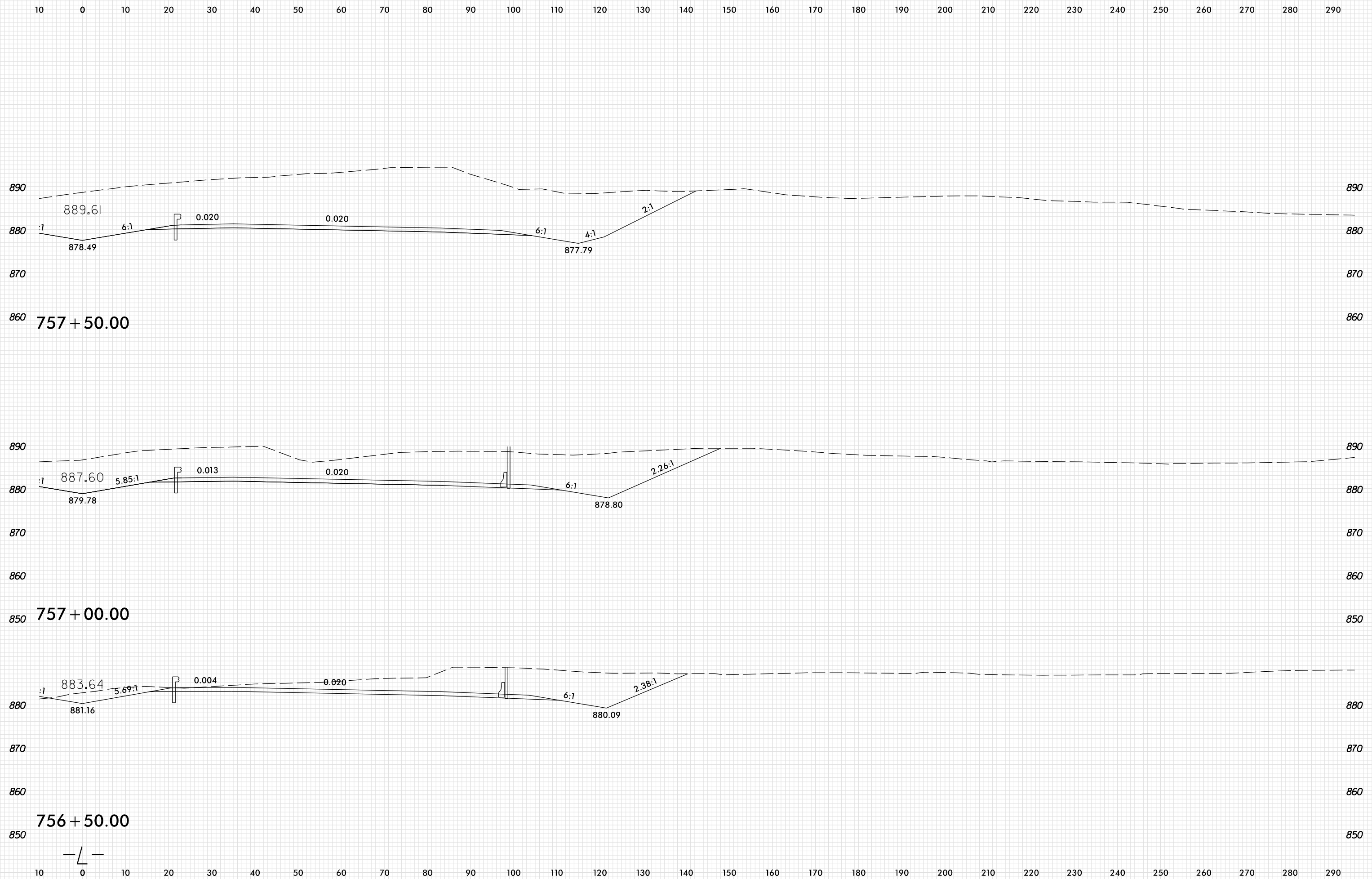

PLOT DRIVER: NCDOT_pdf_color_eng_100.plt
 USER: SPEREIRA
 DATE: 6/10/2021
 TIME: 2:18:00 PM
 FILE: \

8/23/99

0 5 10	PROJ. REFERENCE NO.	SHEET NO.
	U-2579AB	X-126

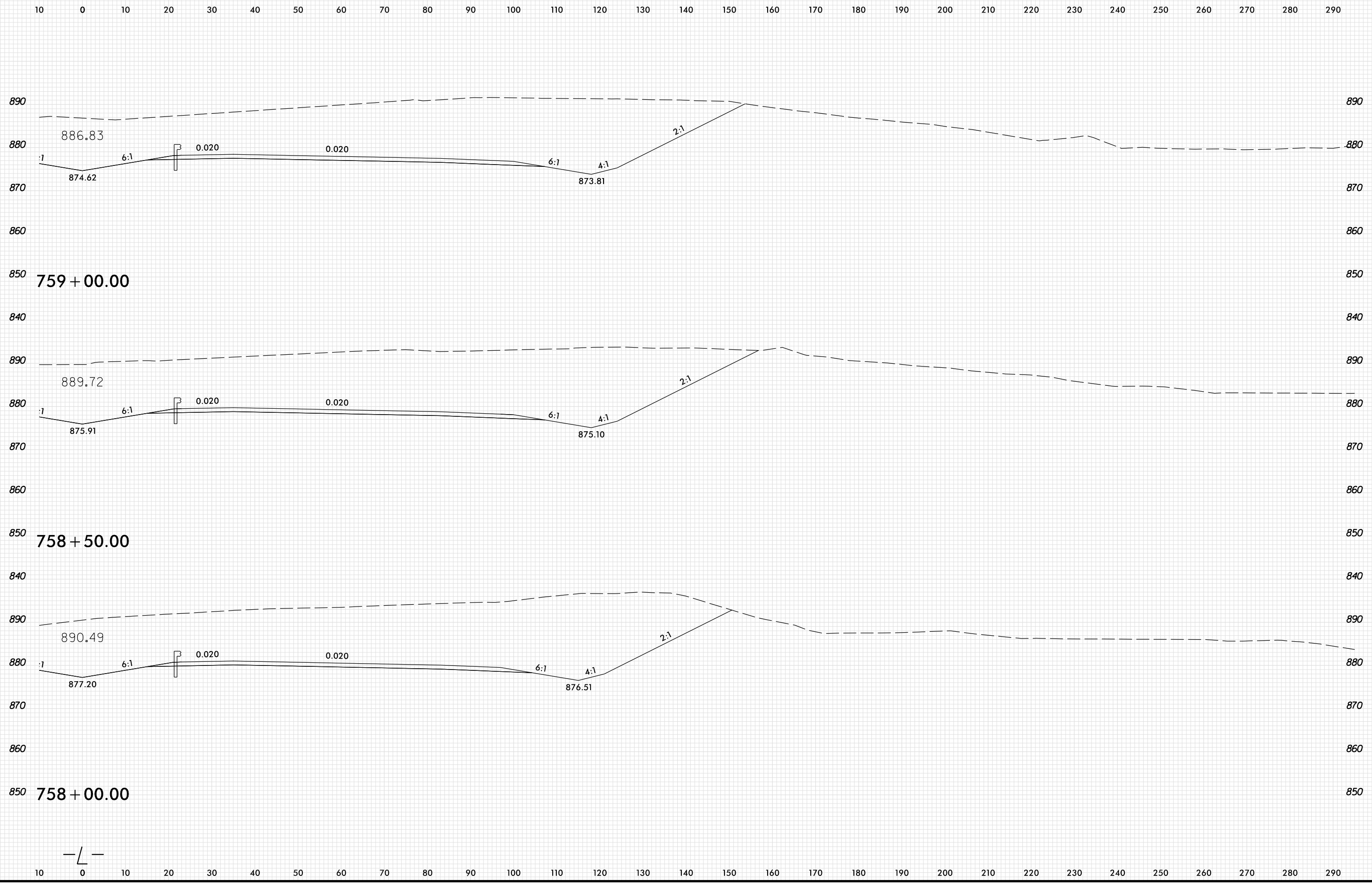

PLOT DRIVER: NCDOT_pdf_color_eng_100.plt
 USER: SPEREIRA
 DATE: 6/10/2021
 TIME: 2:18:00 PM
 FILE: \

8/23/99

0 5 10	PROJ. REFERENCE NO.	SHEET NO.
	U-2579AB	X-127

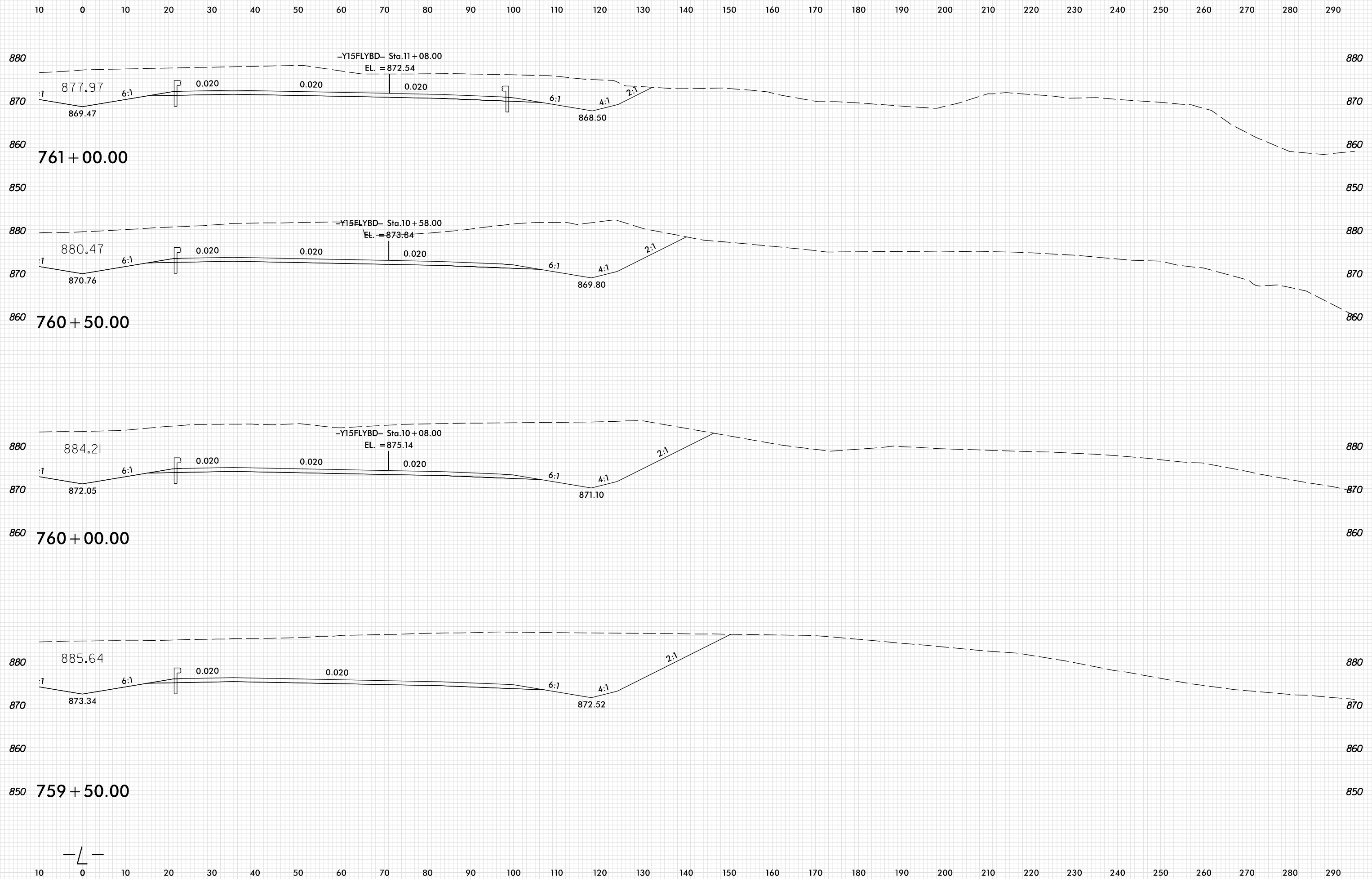

PLOT DRIVER: NCDOT_pdf_color_eng_100.plt
 USER: SPEREIRA
 DATE: 6/10/2021
 TIME: 2:18:01 PM
 FILE: \

8/23/99

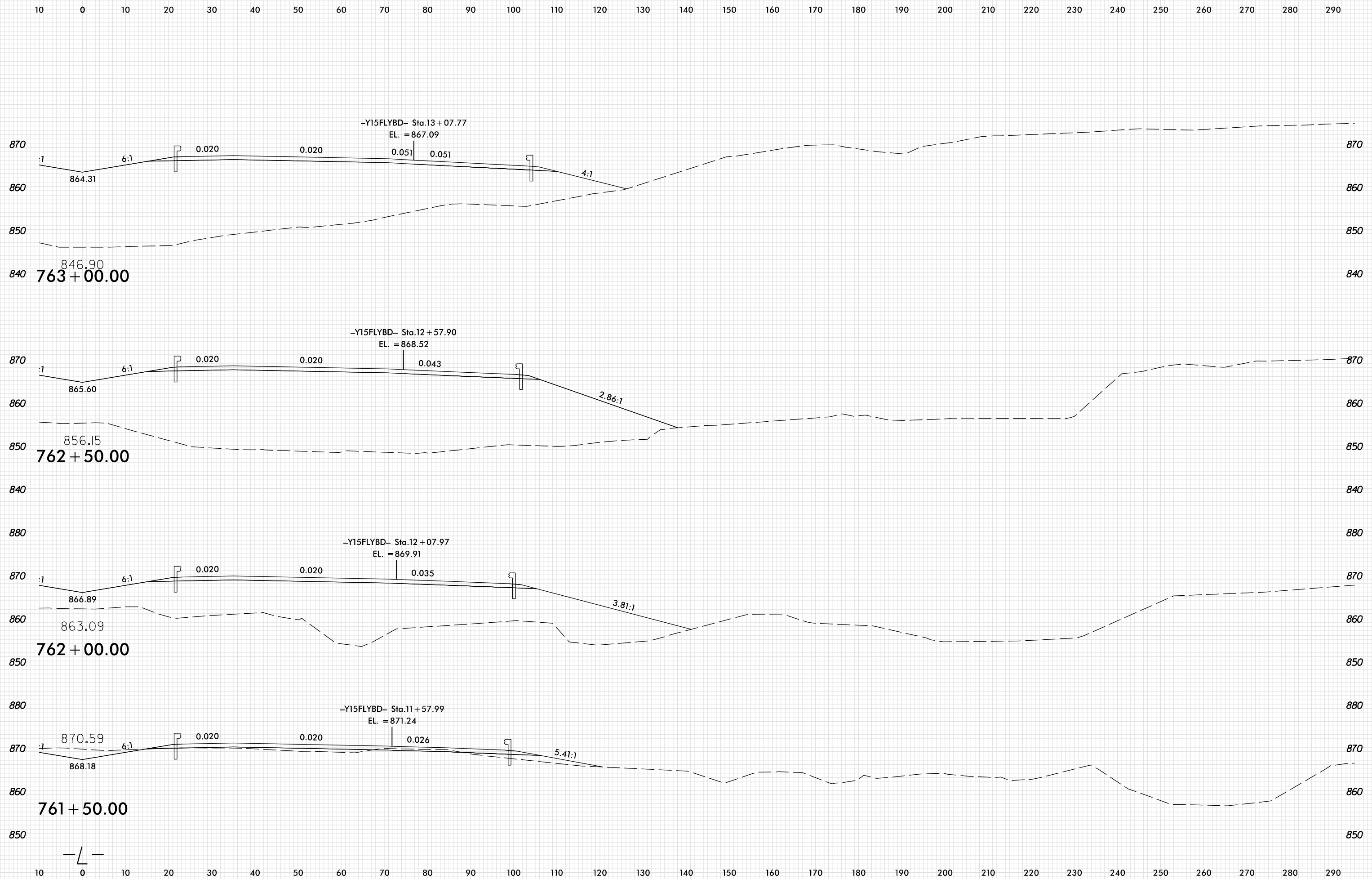

PLOT DRIVER: NCDOT_pdf_color_eng_100.plt
 USER: SPEREIRA
 DATE: 6/10/2021
 TIME: 2:18:01 PM
 FILE: \

8/23/99

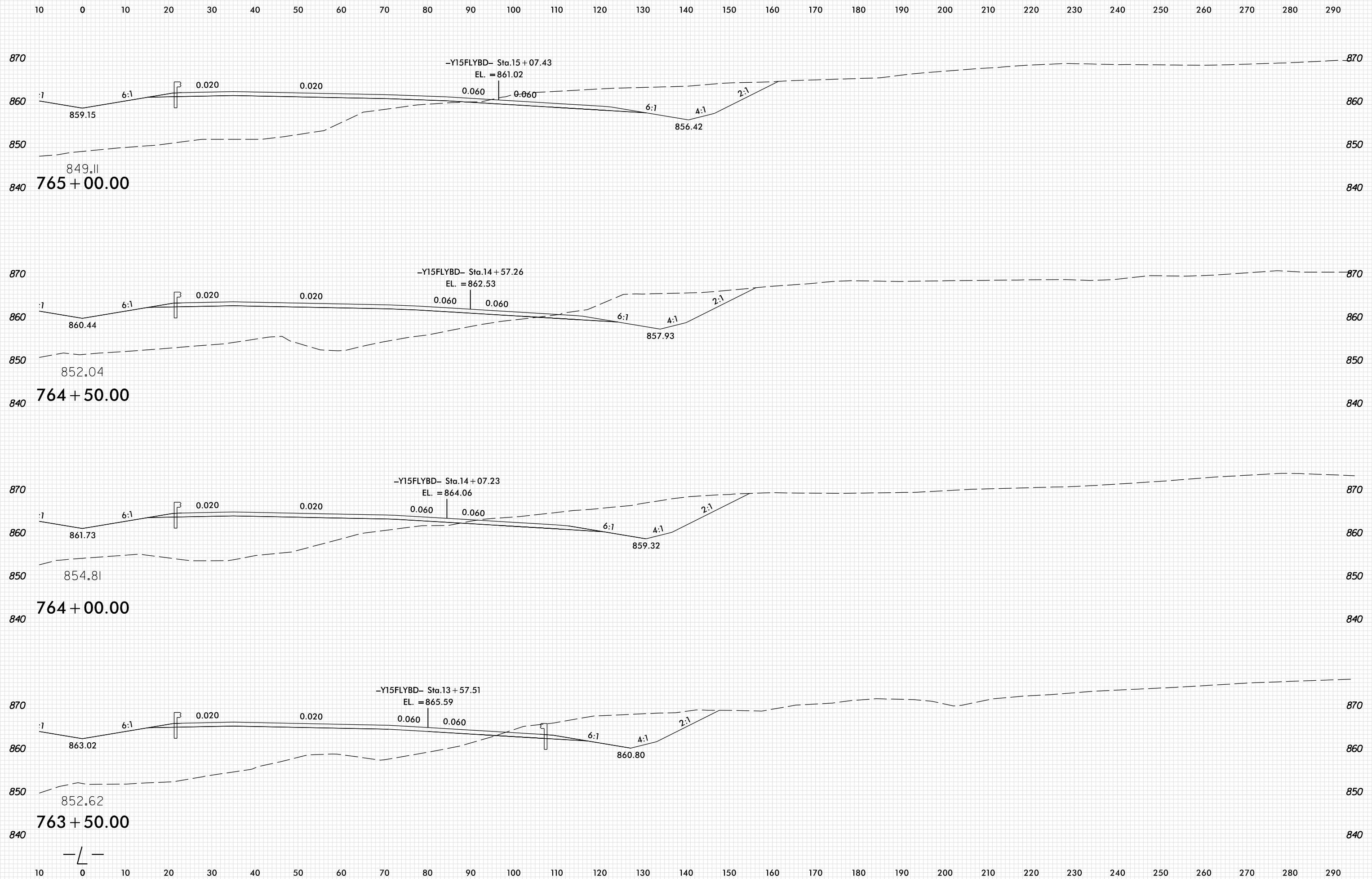

PLOT DRIVER: NCD01_pdf_color_eng_100.plt
 USER: SPEREIRA
 DATE: 6/10/2021
 TIME: 2:18:02 PM
 FILE: \

8/23/99

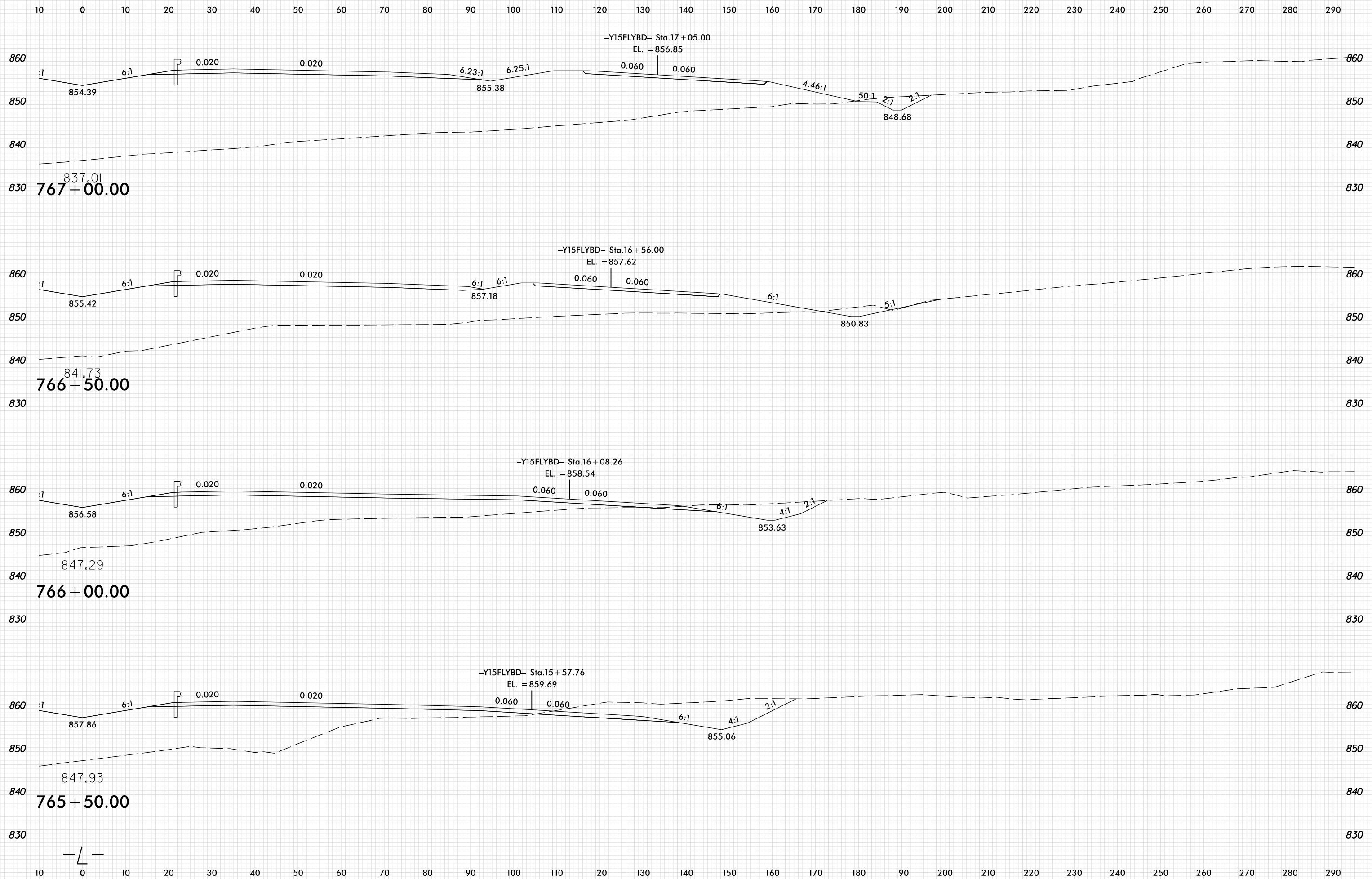

PLOT DRIVER: NCDOT_pdf_color_eng_100.plt
 USER: SPEREIRA
 DATE: 6/10/2021
 TIME: 2:18:03 PM
 FILE: \

8/23/99

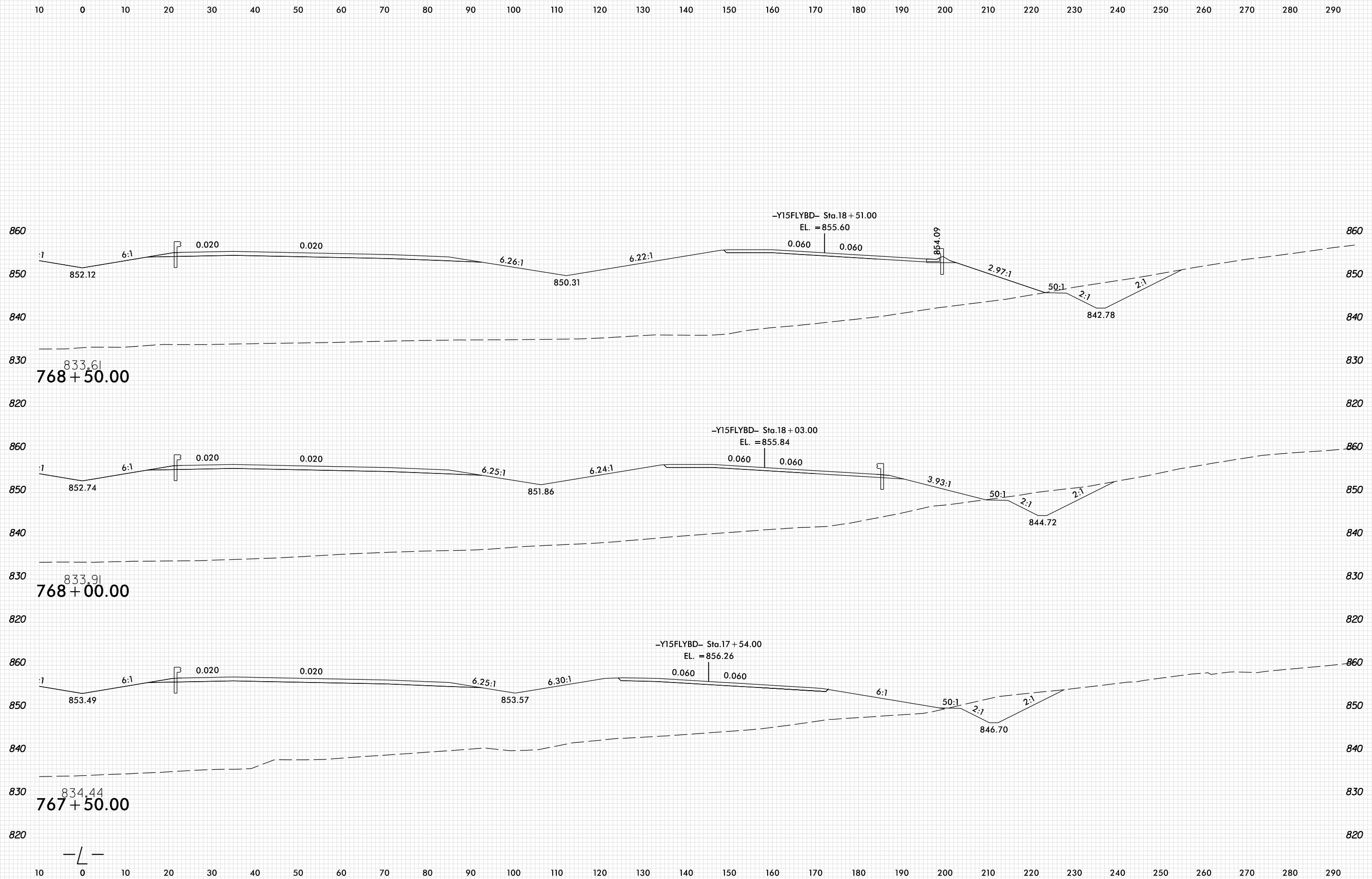

PLOT DRIVER: NCD01...
 USER: SPEREIRA
 DATE: 6/10/2021
 TIME: 2:18:03 PM

—/—

8/23/99

0 5 10	PROJ. REFERENCE NO.	SHEET NO.
	U-2579AB	X-132

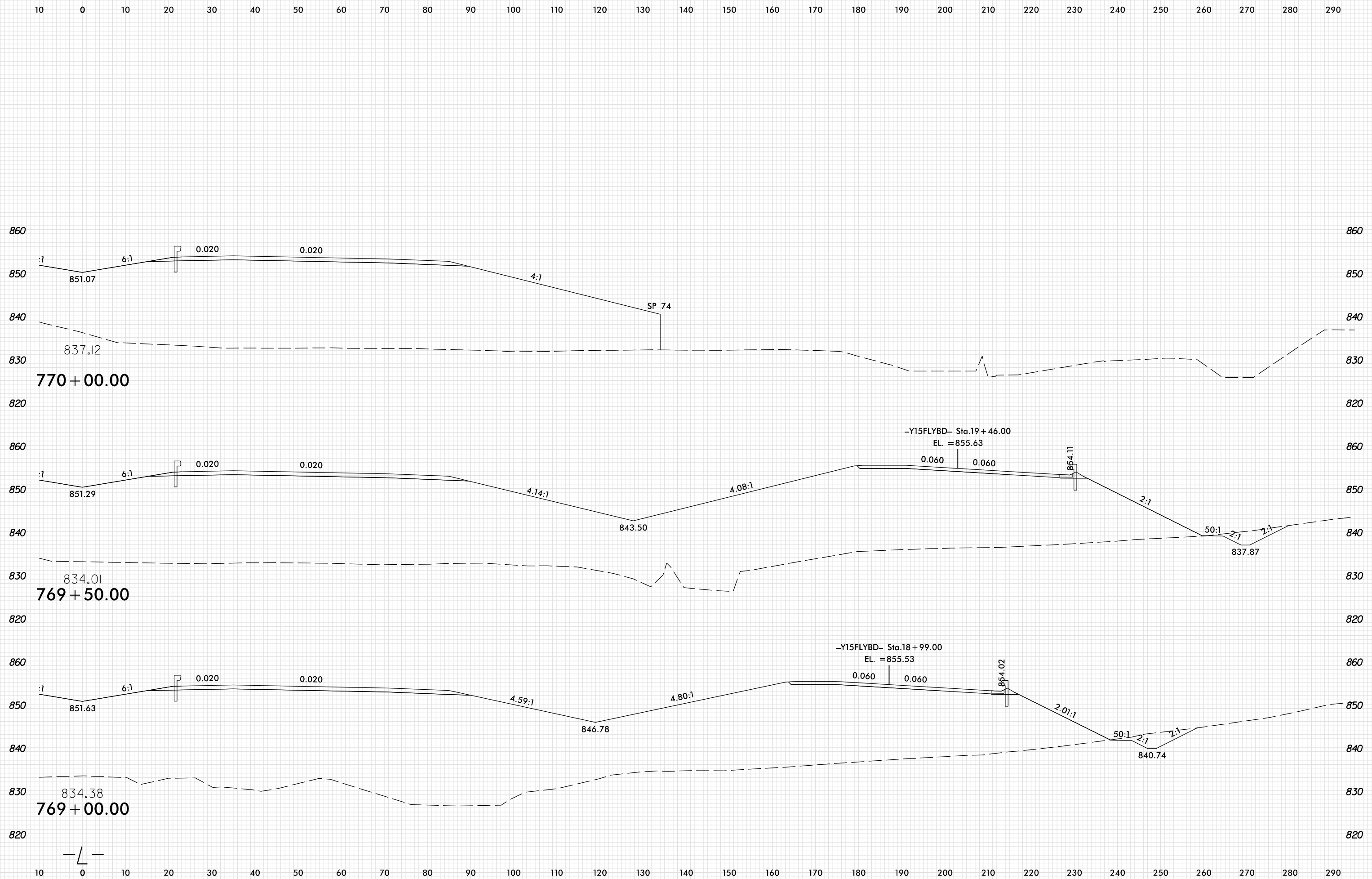

PLOT DRIVER: NCD01_pdf_color_eng_100.plt
 USER: SPEREIRA
 DATE: 6/10/2021
 TIME: 2:18:04 PM
 FILE: \

8/23/99

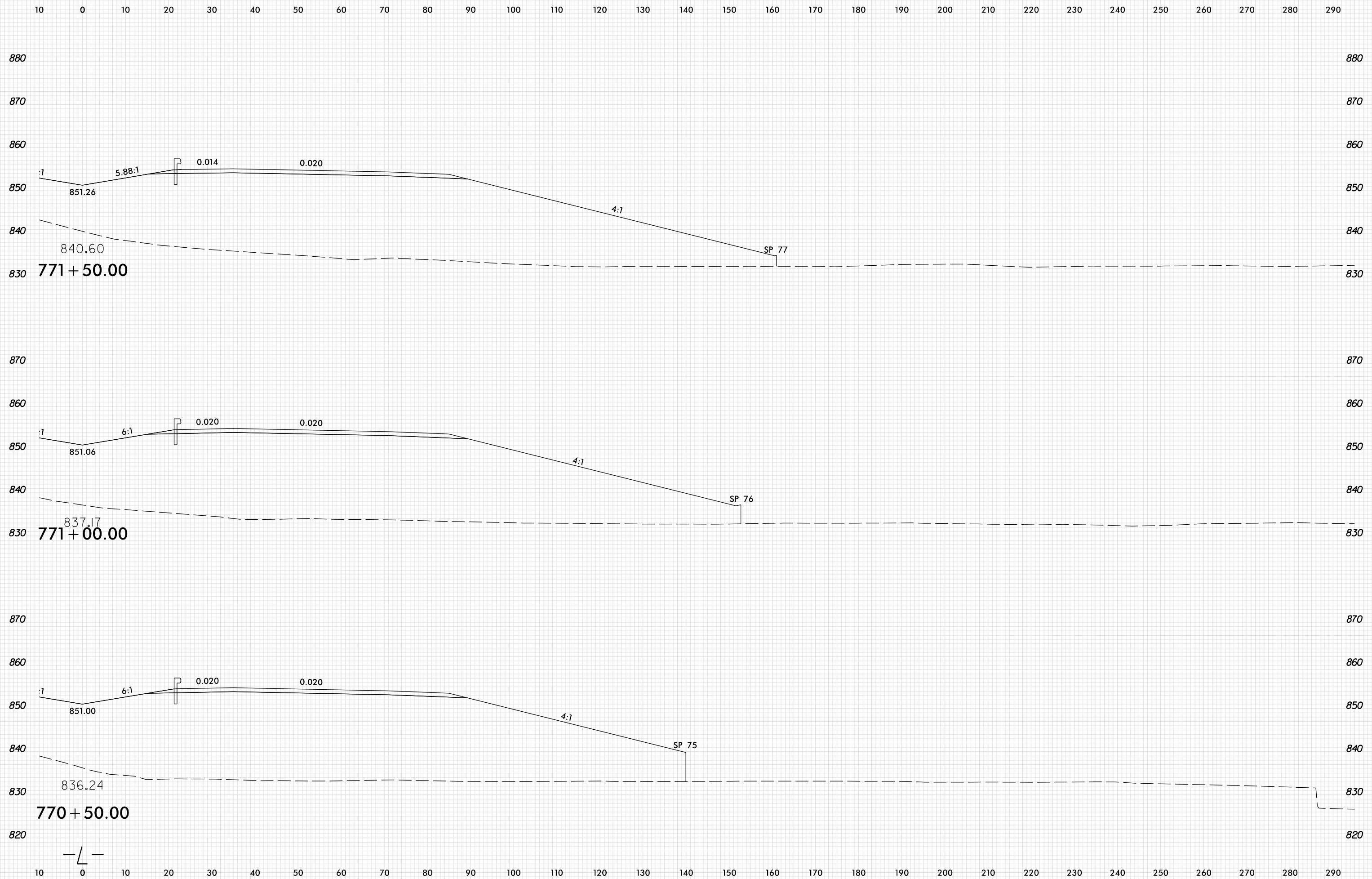

PLOT DRIVER: NCD01_pdf_color_eng_100.plt
 USER: SPEREIRA
 DATE: 6/10/2021
 TIME: 2:18:04 PM
 FILE: \

8/23/99

0 5 10	PROJ. REFERENCE NO.	SHEET NO.
	U-2579AB	X-134

10 0 10 20 30 40 50 60 70 80 90 100 110 120 130 140 150 160 170 180 190 200 210 220 230 240 250 260 270 280 290

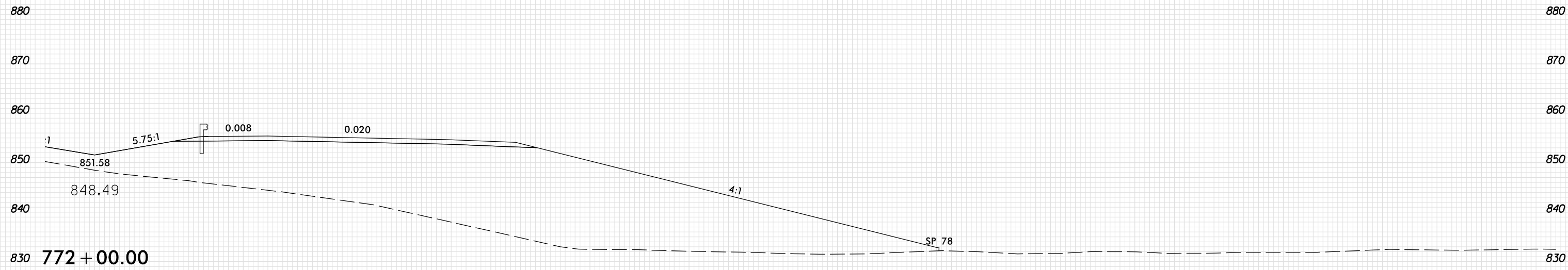
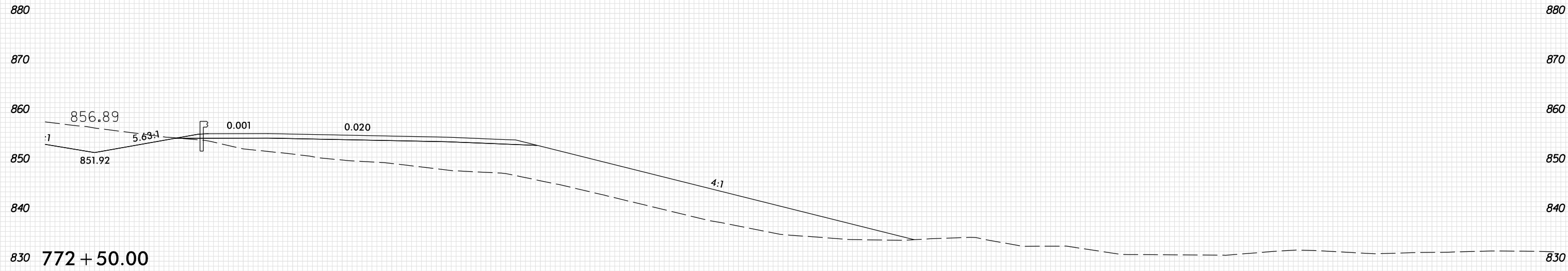

10 0 10 20 30 40 50 60 70 80 90 100 110 120 130 140 150 160 170 180 190 200 210 220 230 240 250 260 270 280 290

PLOT DRIVER: NCDOT_pdf_color_eng_100.plt
 USER: SPEREIRA
 DATE: 6/10/2021
 TIME: 2:18:05 PM
 FILE: \



8/23/99

10 0 10 20 30 40 50 60 70 80 90 100 110 120 130 140 150 160 170 180 190 200 210 220 230 240 250 260 270 280 290

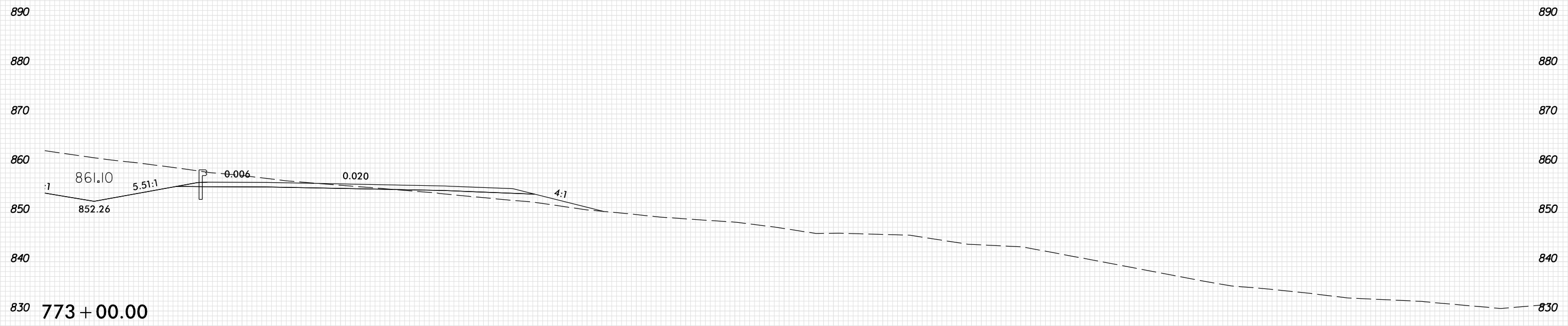
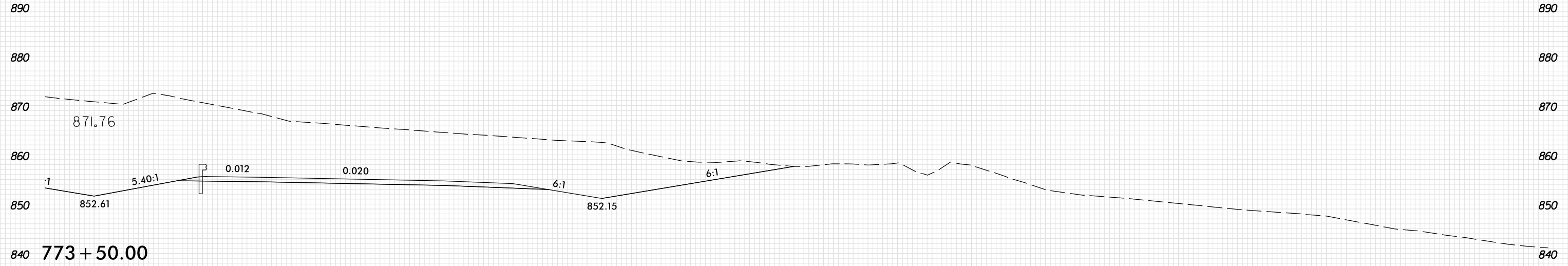

10 0 10 20 30 40 50 60 70 80 90 100 110 120 130 140 150 160 170 180 190 200 210 220 230 240 250 260 270 280 290

PLOT DRIVER: NCDOT_pdf_color_eng_100.plt
USER: SPEREIRA
DATE: 6/10/2021
TIME: 2:18:06 PM
FILE: \



8/23/99

0 5 10	PROJ. REFERENCE NO.	SHEET NO.
	U-2579AB	X-136

10 0 10 20 30 40 50 60 70 80 90 100 110 120 130 140 150 160 170 180 190 200 210 220 230 240 250 260 270 280 290

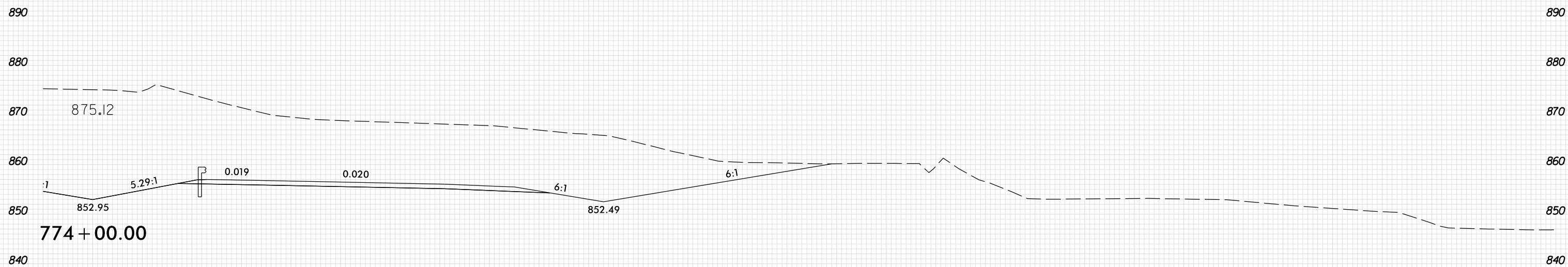
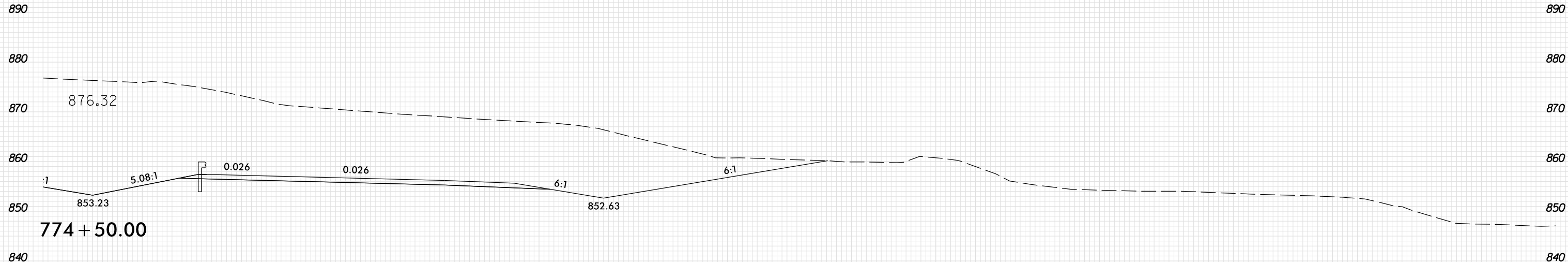

10 0 10 20 30 40 50 60 70 80 90 100 110 120 130 140 150 160 170 180 190 200 210 220 230 240 250 260 270 280 290

PLOT DRIVER: NCD01_pdf_color_eng_100.plt
 USER: SPEREIRA
 DATE: 6/10/2021
 TIME: 2:18:06 PM
 FILE: \

8/23/99

0 5 10	PROJ. REFERENCE NO.	SHEET NO.
	U-2579AB	X-137

10 0 10 20 30 40 50 60 70 80 90 100 110 120 130 140 150 160 170 180 190 200 210 220 230 240 250 260 270 280 290

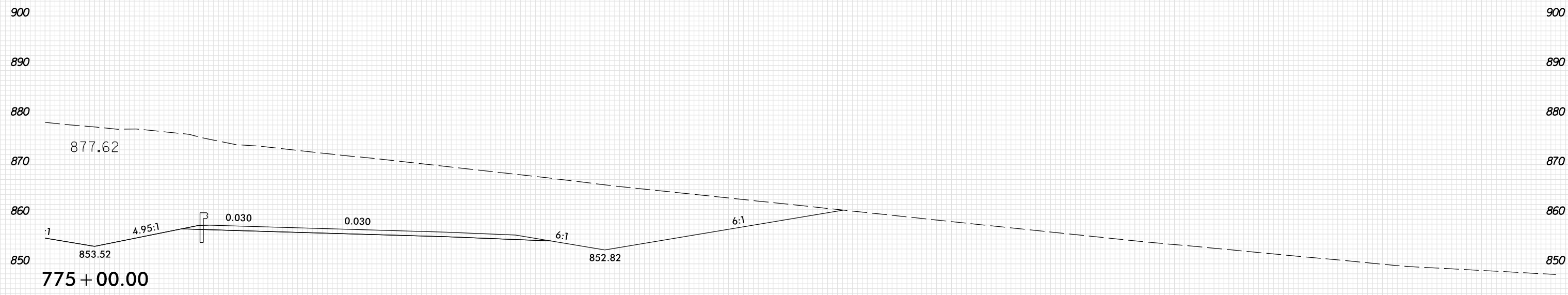
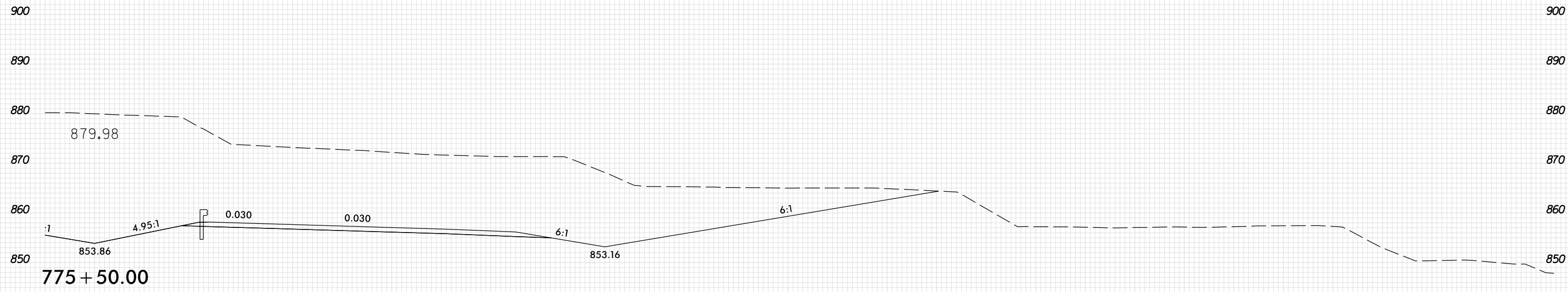

10 0 10 20 30 40 50 60 70 80 90 100 110 120 130 140 150 160 170 180 190 200 210 220 230 240 250 260 270 280 290

PLOT DRIVER: NCDOT_pdf_color_eng_100.plt
 USER: SPEREIRA
 DATE: 6/10/2021
 TIME: 2:18:07 PM
 FILE: \

8/23/99

0 5 10	PROJ. REFERENCE NO.	SHEET NO.
	U-2579AB	X-138

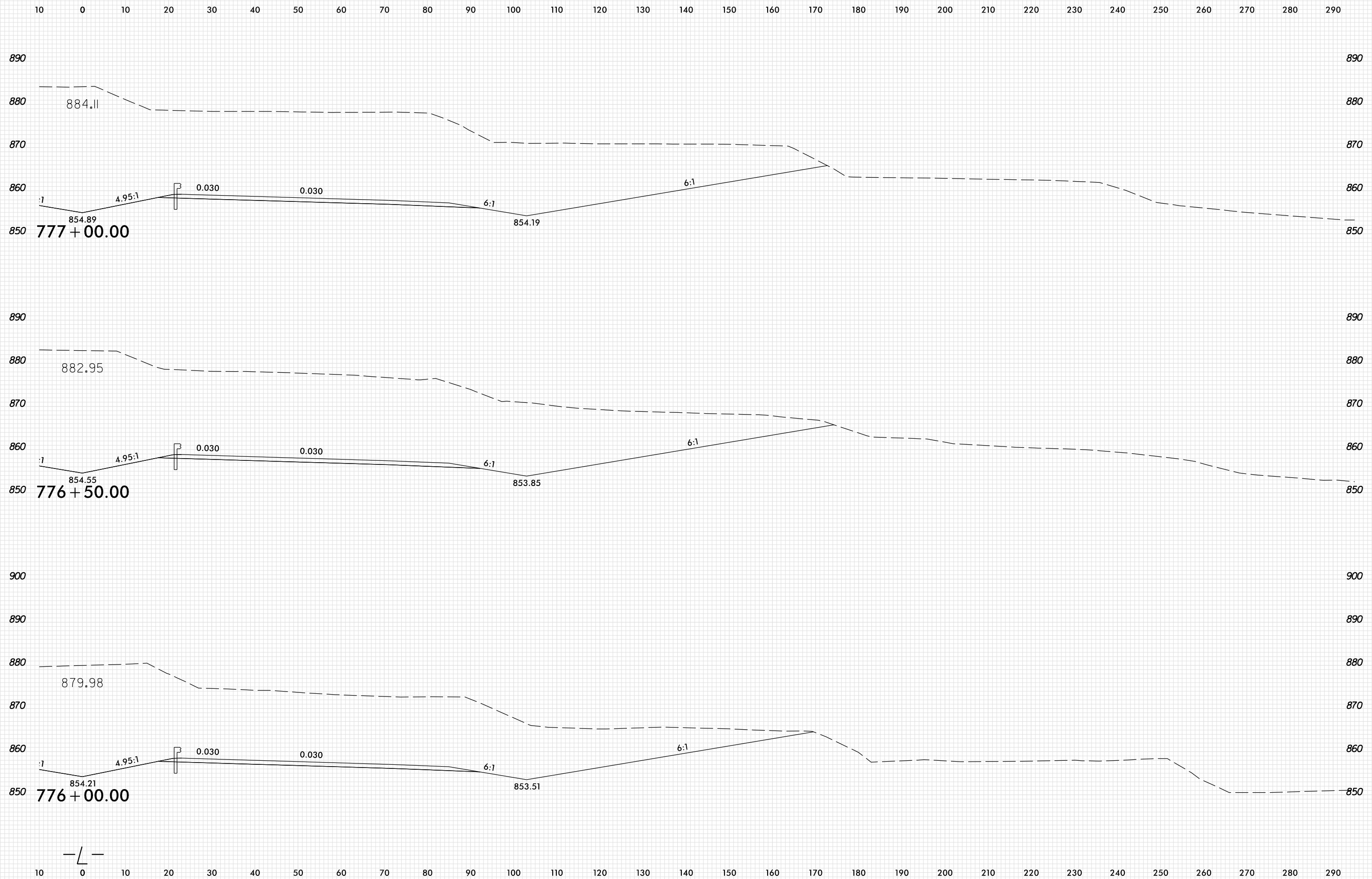

PLOT DRIVER: NCDOT_pdf_color_eng_100.plt
 USER: SPEREIRA
 DATE: 6/10/2021
 TIME: 2:18:07 PM
 FILE: \



8/23/99

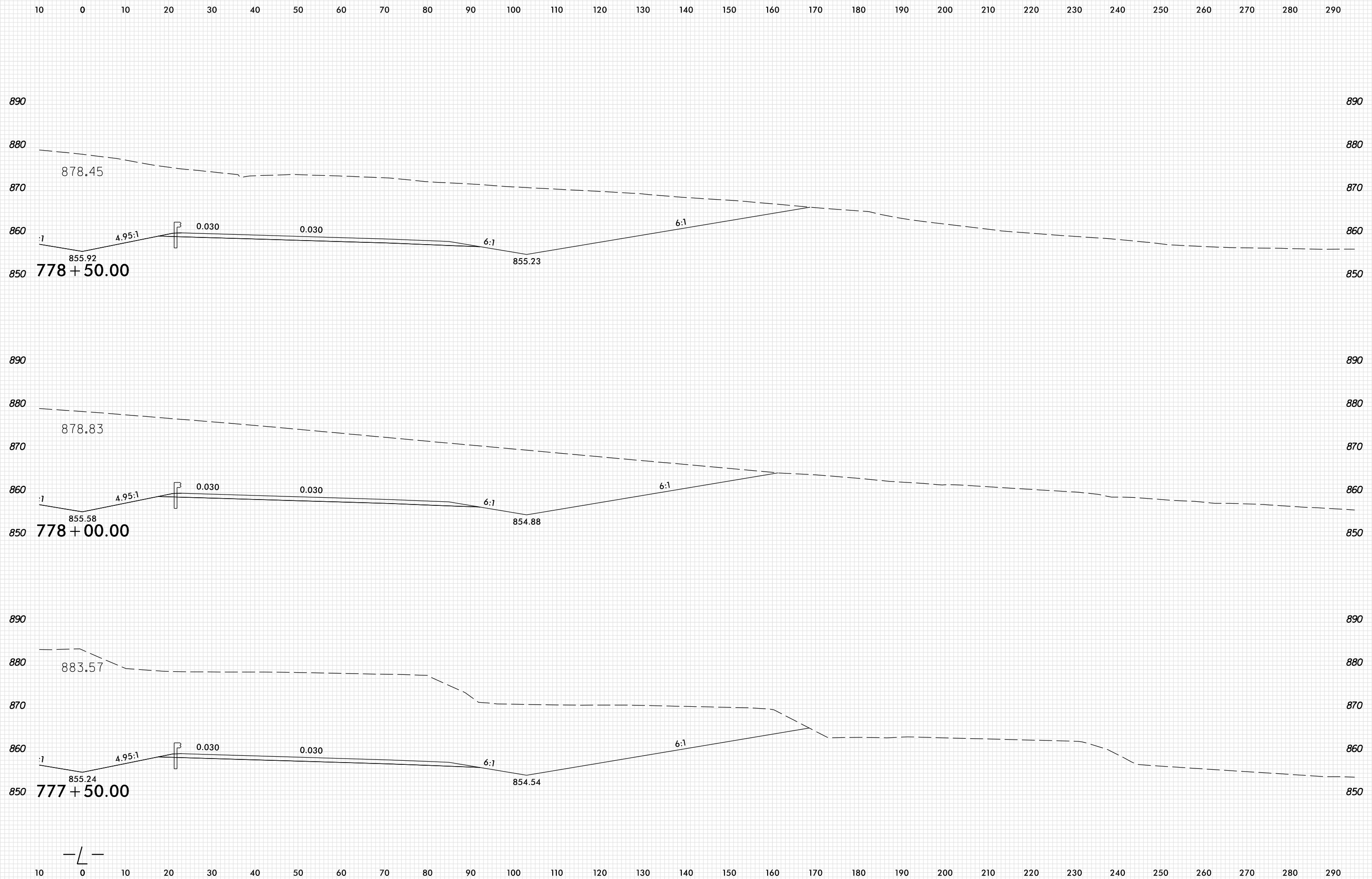

PLOT DRIVER: NCDOT_pdf_color_eng_100.plt
 USER: SPEREIRA
 DATE: 6/10/2021
 TIME: 2:18:08 PM
 FILE: \



8/23/99

10 0 10 20 30 40 50 60 70 80 90 100 110 120 130 140 150 160 170 180 190 200 210 220 230 240 250 260 270 280 290

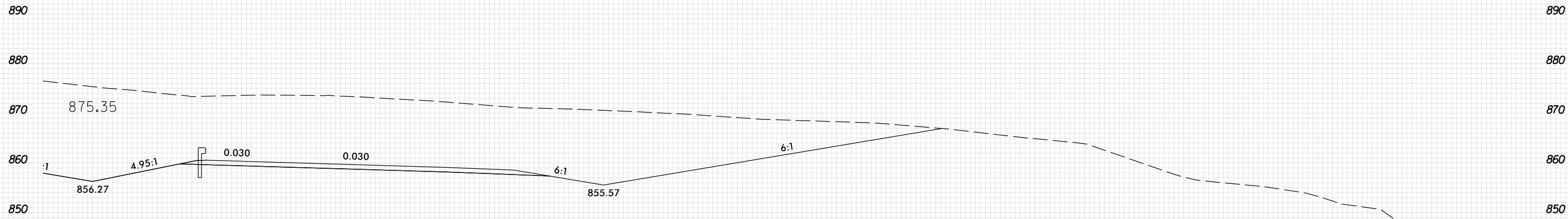
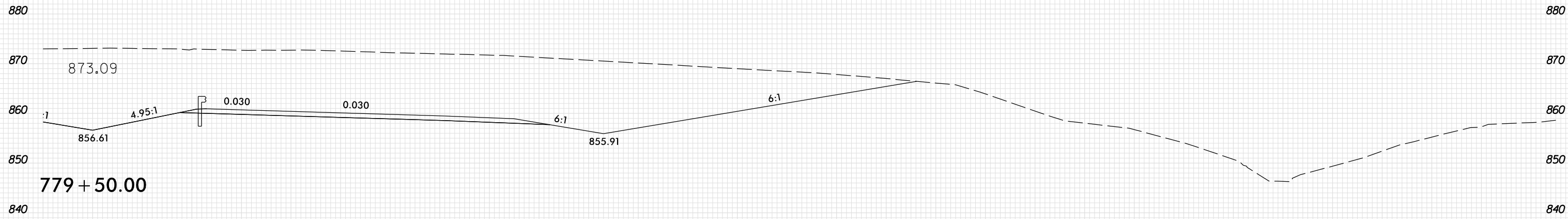
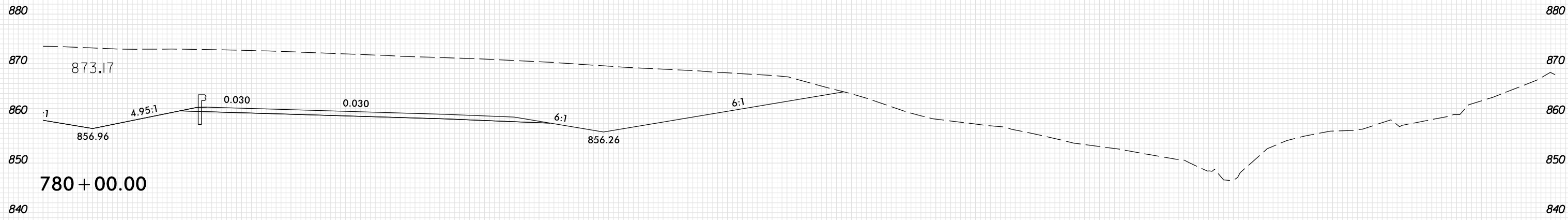

10 0 10 20 30 40 50 60 70 80 90 100 110 120 130 140 150 160 170 180 190 200 210 220 230 240 250 260 270 280 290

PLOT DRIVER: NCDOT_pdf_color_eng_100.plt
USER: SPEREIRA
DATE: 6/10/2021
TIME: 2:18:09 PM
FILE: \

8/23/99

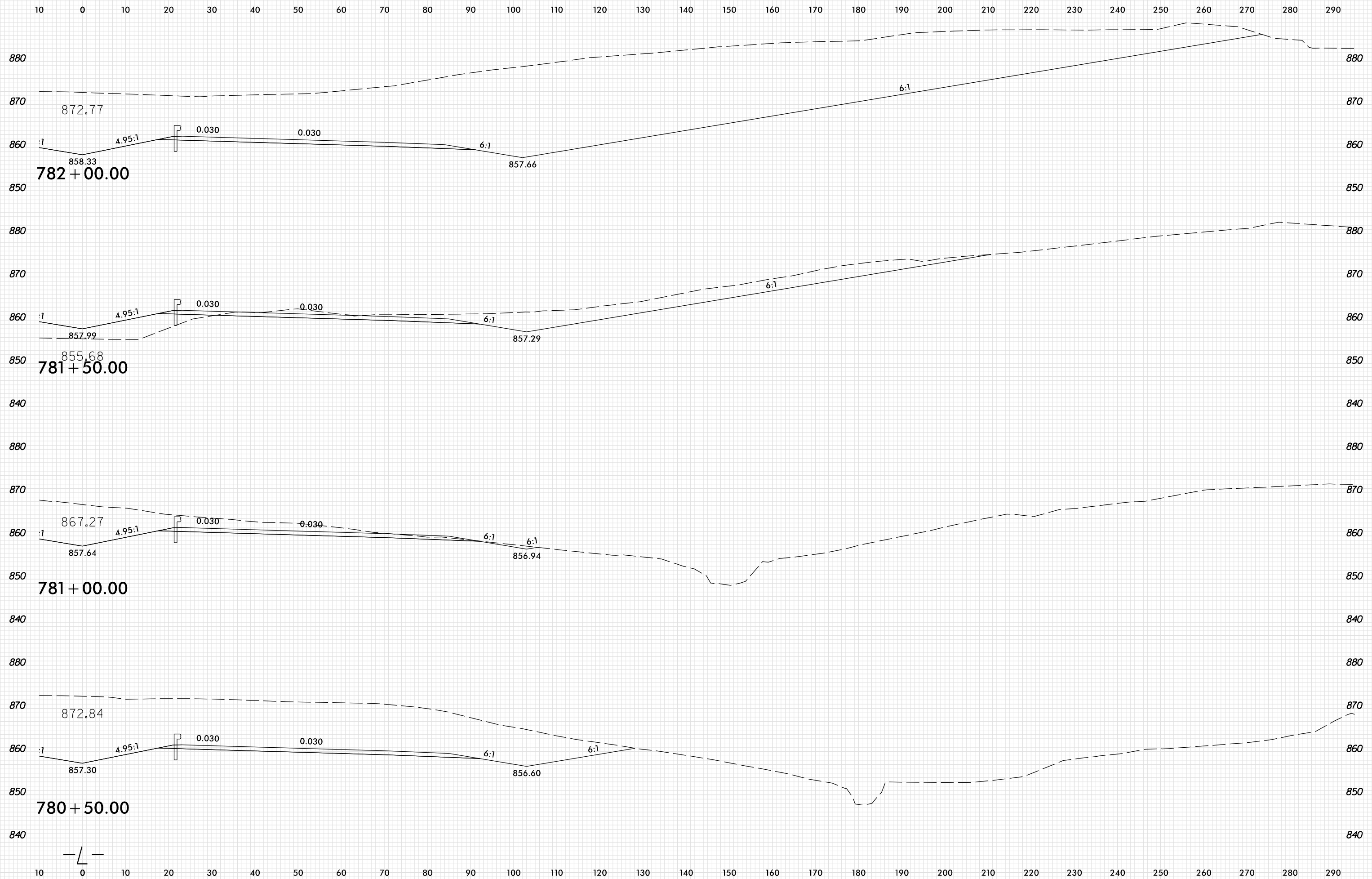

PLOT DRIVER: NCDOT_pdf_color_eng_100.plt
 USER: SPEREIRA
 DATE: 6/10/2021
 TIME: 2:18:09 PM
 FILE: \

8/23/99



PROJ. REFERENCE NO.	SHEET NO.
U-2579AB	X-142

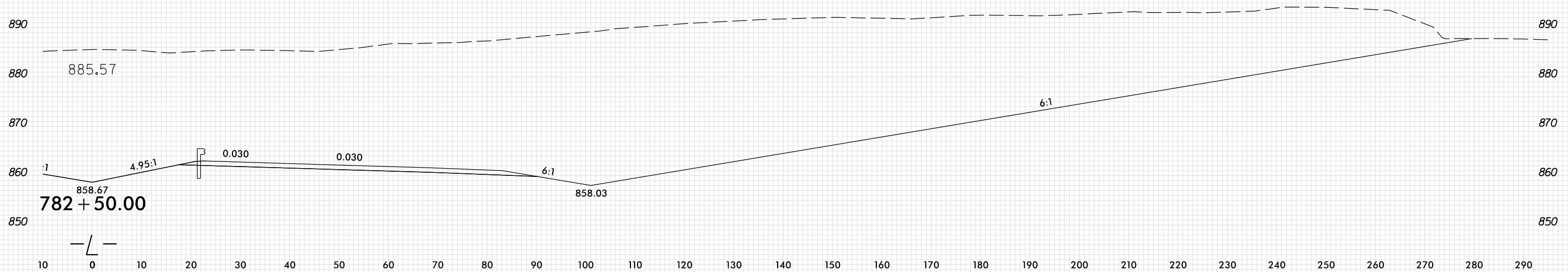
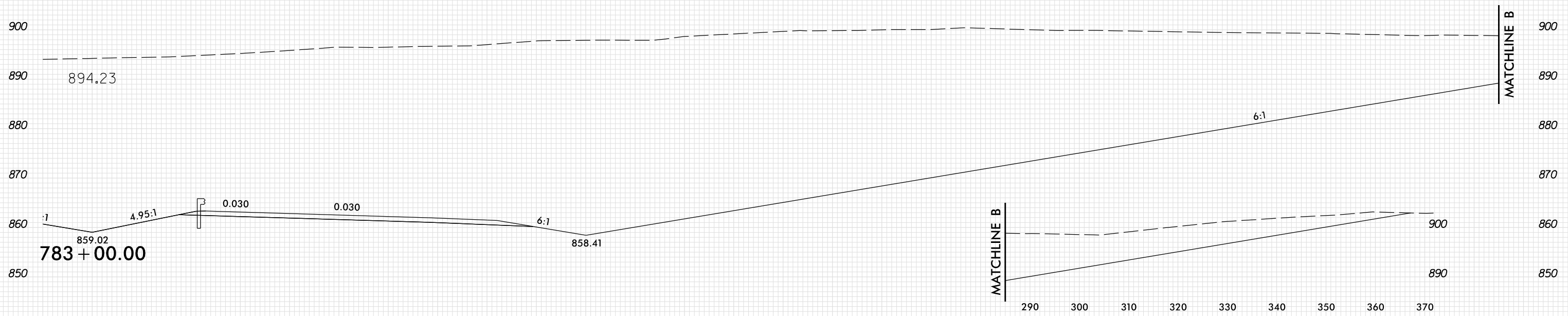
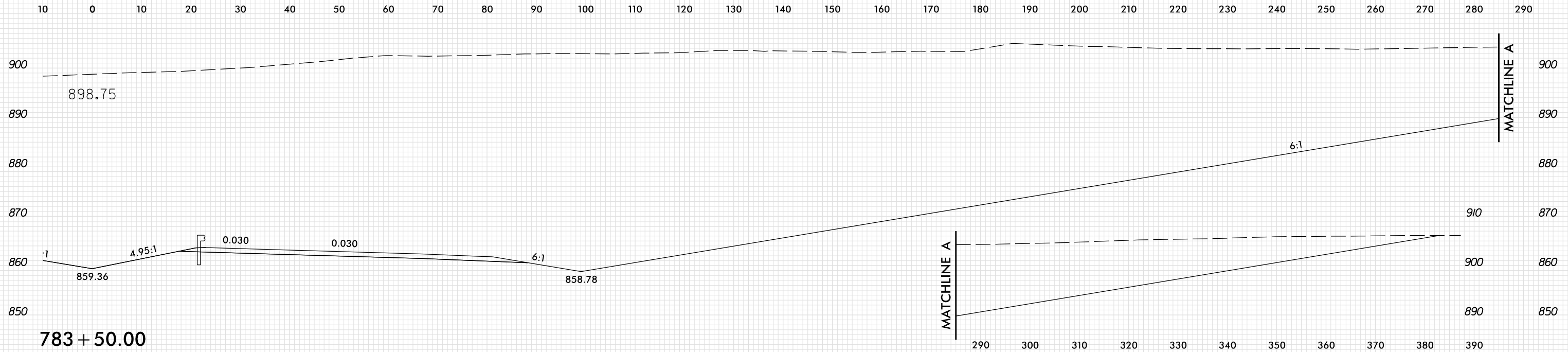

PLOT DRIVER: NCDOT_pdf_color_eng_100.plt
 USER: SPEREIRA
 DATE: 6/10/2021
 TIME: 2:18:10 PM
 FILE: \

8/23/99



PROJ. REFERENCE NO.	SHEET NO.
U-2579AB	X-143

10 0 10 20 30 40 50 60 70 80 90 100 110 120 130 140 150 160 170 180 190 200 210 220 230 240 250 260 270 280 290

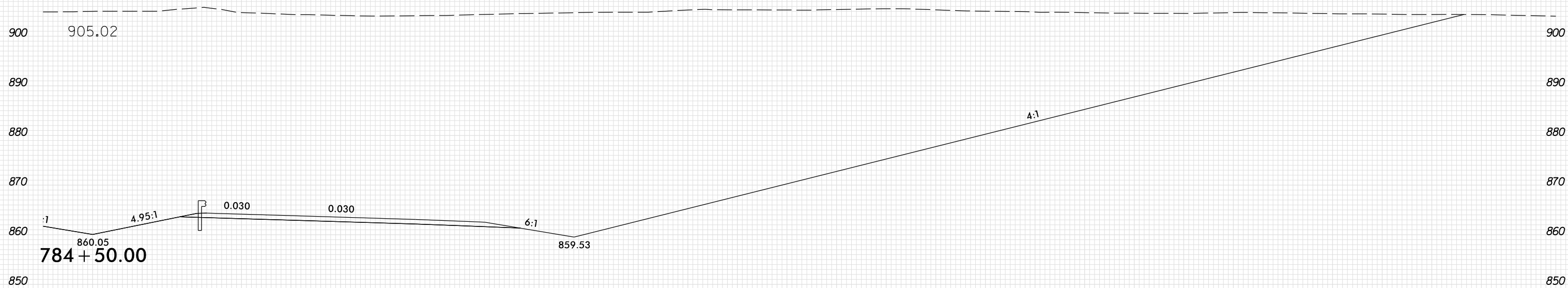

PLOT DRIVER: NCDOT_pdf_color_eng_100.plt
 USER: SPEREIRA
 DATE: 6/10/2021
 TIME: 2:18:11 PM
 FILE: \

—/—

8/23/99

10 0 10 20 30 40 50 60 70 80 90 100 110 120 130 140 150 160 170 180 190 200 210 220 230 240 250 260 270 280 290

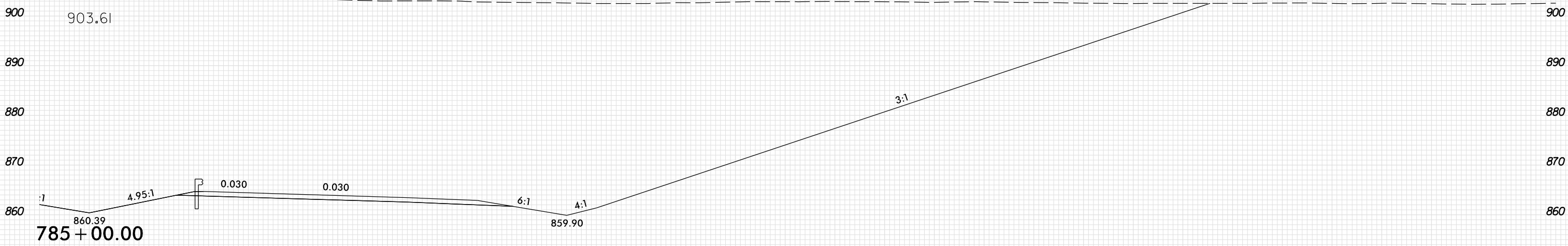
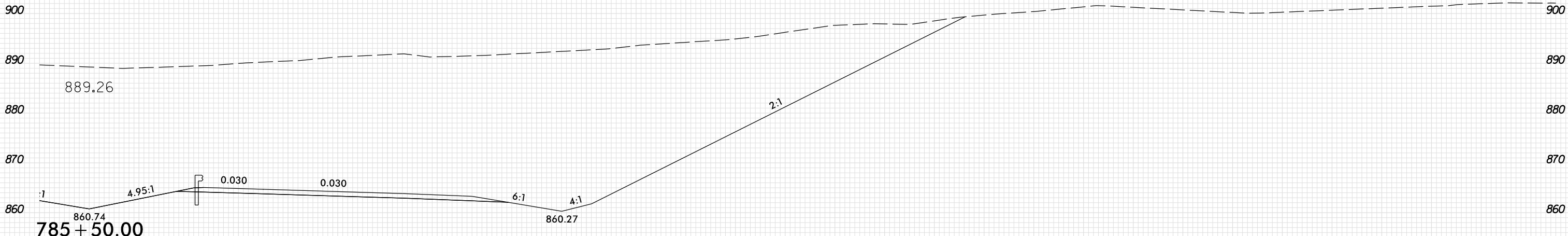
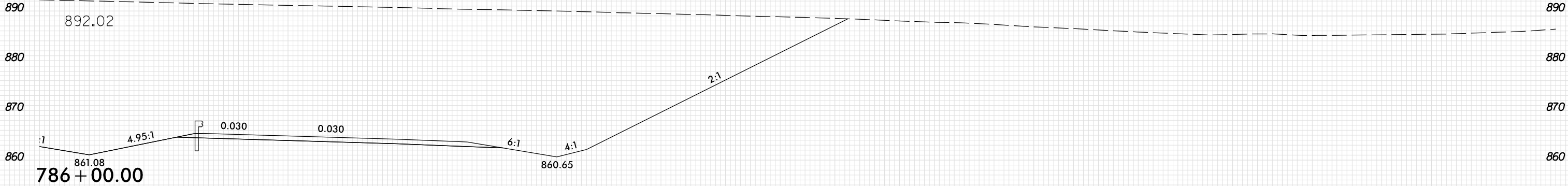

10 0 10 20 30 40 50 60 70 80 90 100 110 120 130 140 150 160 170 180 190 200 210 220 230 240 250 260 270 280 290

PLOT DRIVER: NCD01_pdf_color_eng_100.plt
USER: SPEREIRA
DATE: 6/10/2021
TIME: 2:18:11 PM
FILE: \

8/23/99

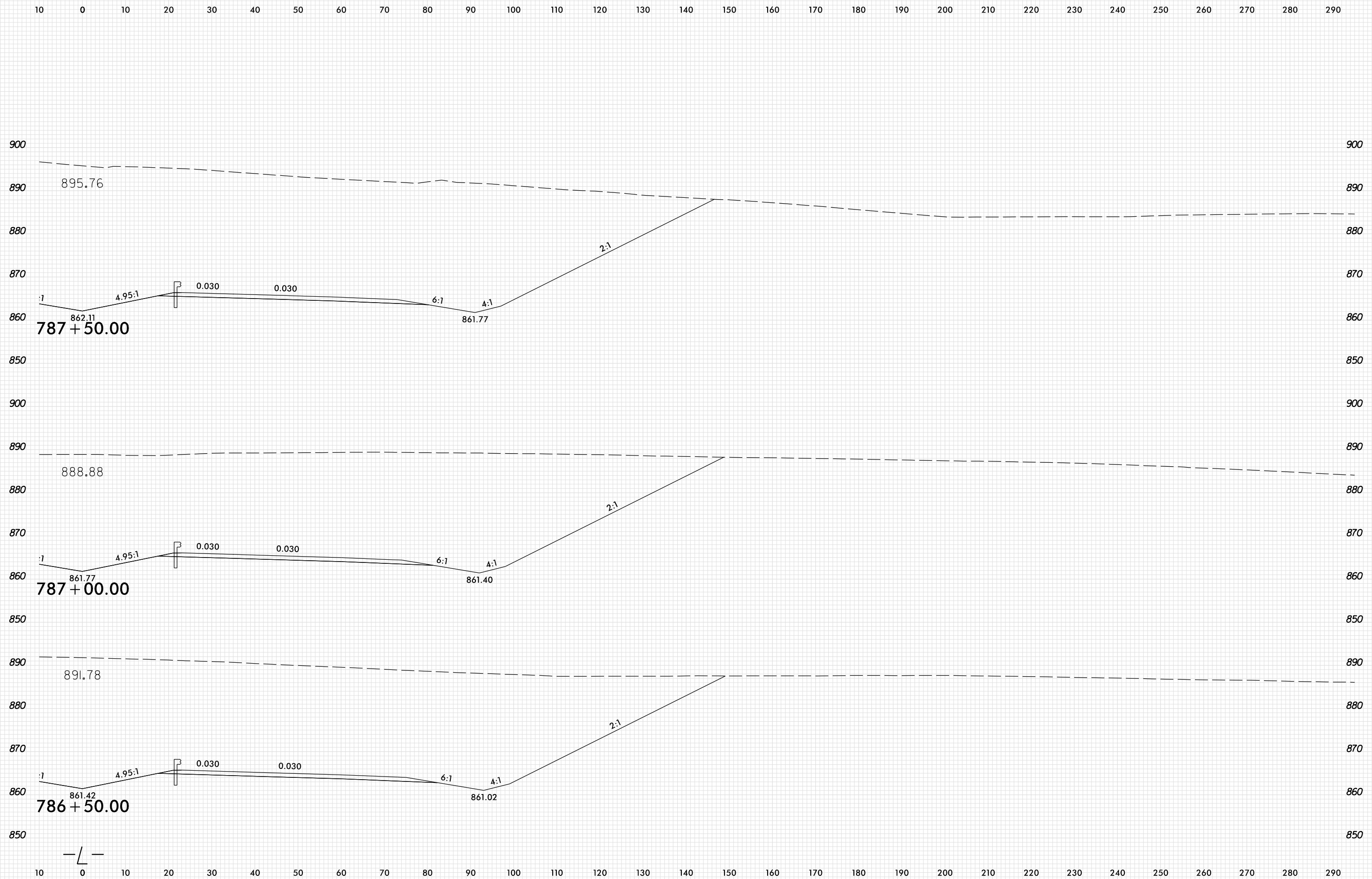

PLOT DRIVER: NCD01_.pdf_color_eng_100.plt
 USER: SPEREIRA
 DATE: 6/10/2021
 TIME: 2:18:12 PM
 FILE: \

8/23/99

0 5 10	PROJ. REFERENCE NO.	SHEET NO.
	U-2579AB	X-146

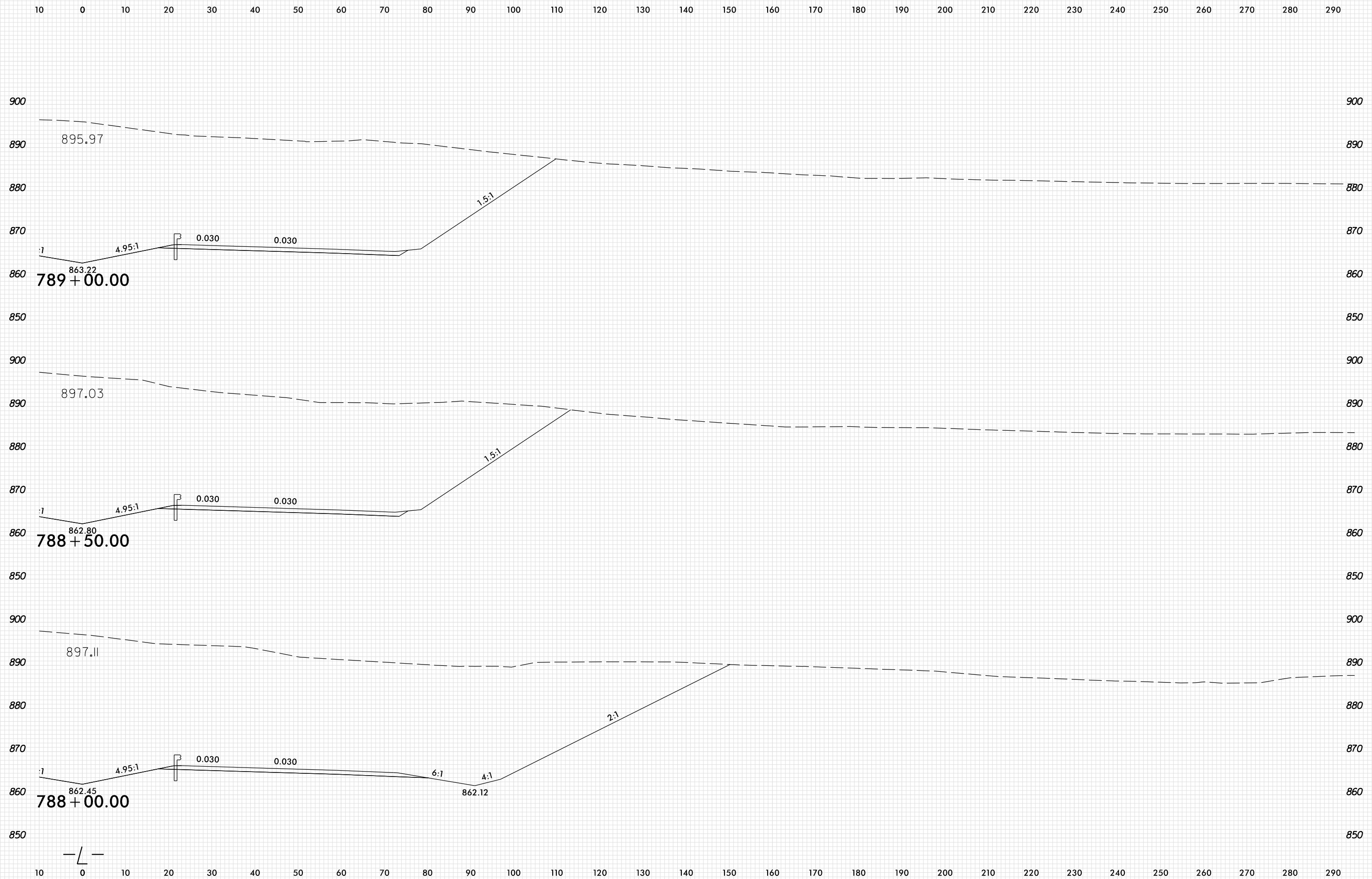

PLOT DRIVER: NCDOT_pdf_color_eng_100.plt
 USER: SPEREIRA
 DATE: 6/10/2021
 TIME: 2:18:12 PM
 FILE: \



8/23/99

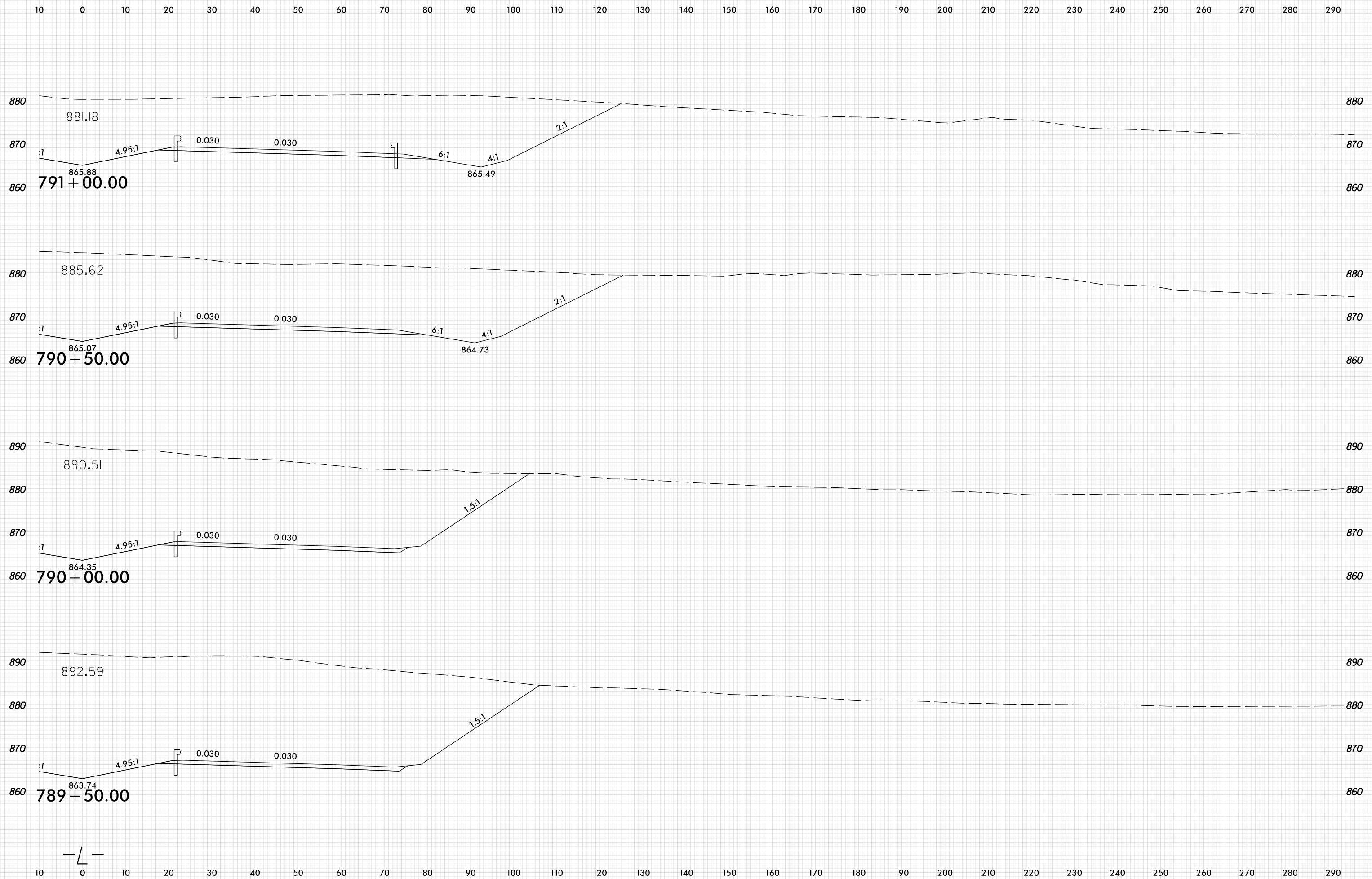

PLOT DRIVER: NCDOT_pdf_color_eng_100.plt
 USER: SPEREIRA
 DATE: 6/10/2021
 TIME: 2:18:13 PM
 FILE: \



8/23/99

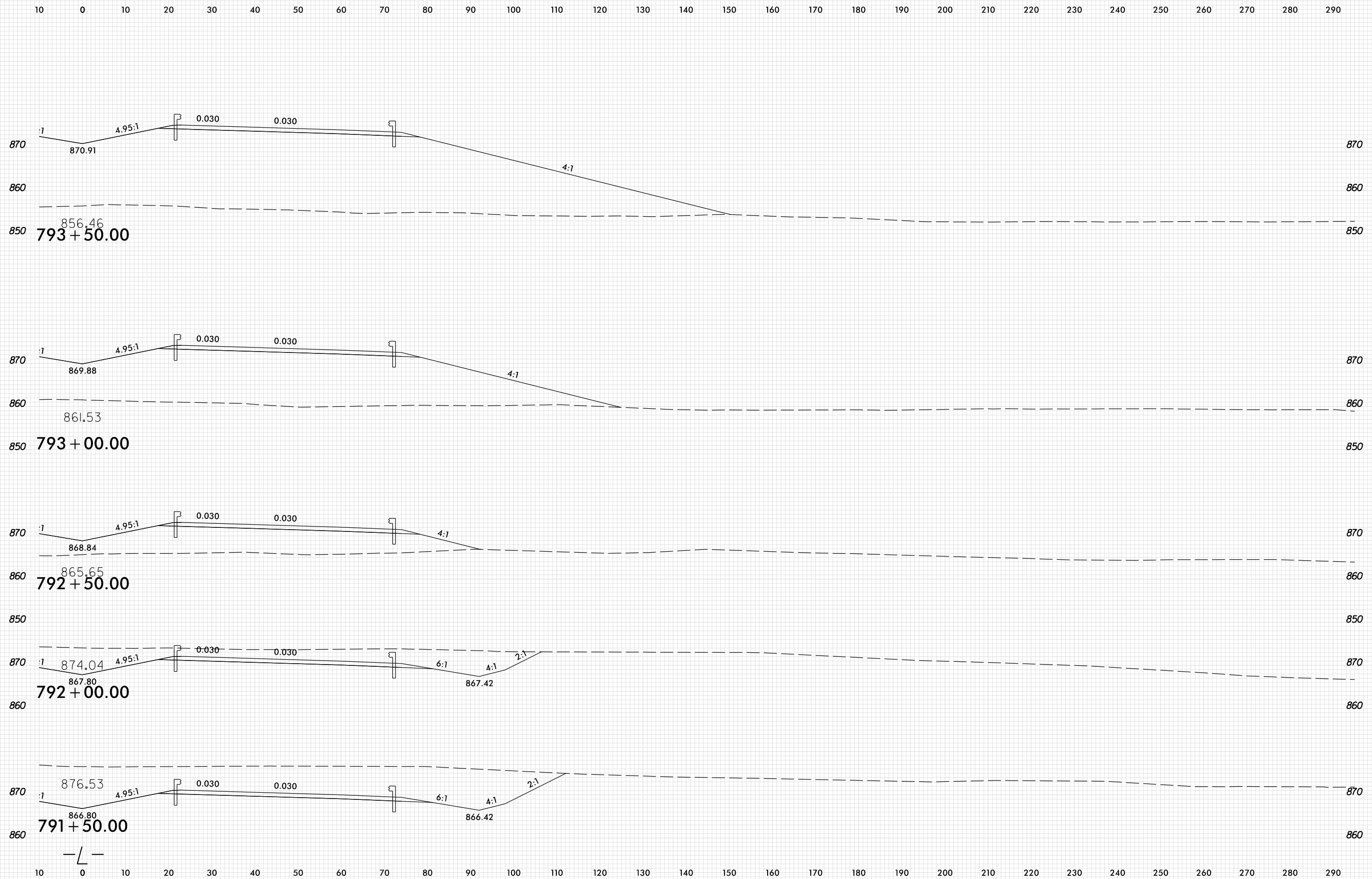

PLOT DRIVER: NCD01_pdf_color_eng_100.plt
 USER: SPEREIRA
 DATE: 6/10/2021
 TIME: 2:18:14 PM
 FILE: \

8/23/99

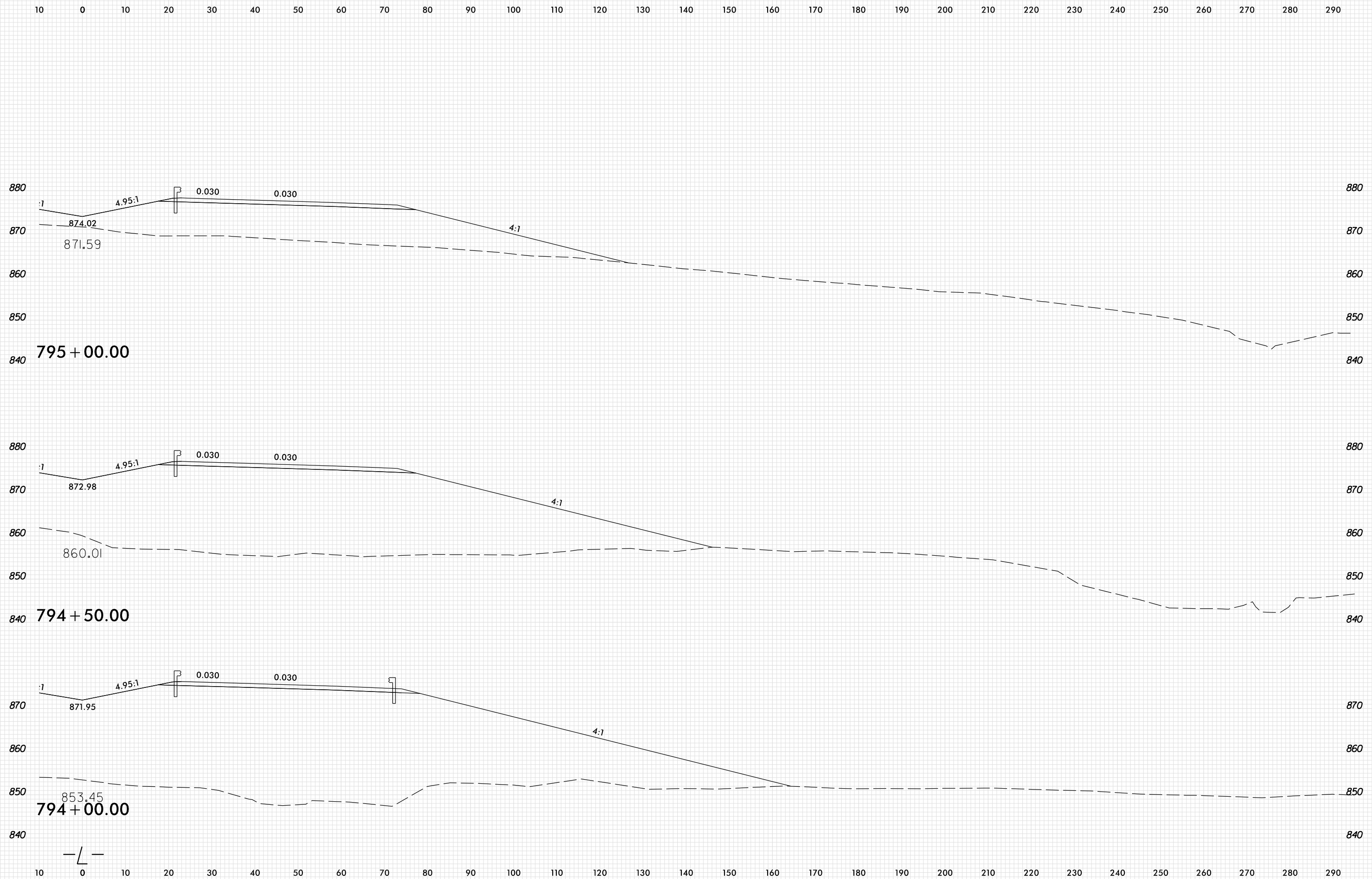

PLOT DRIVER: NCD01_.pdf_color_eng_100.plt
 USER: SPEREIRA
 DATE: 6/10/2021
 TIME: 2:18:15 PM
 FILE: \

8/23/99

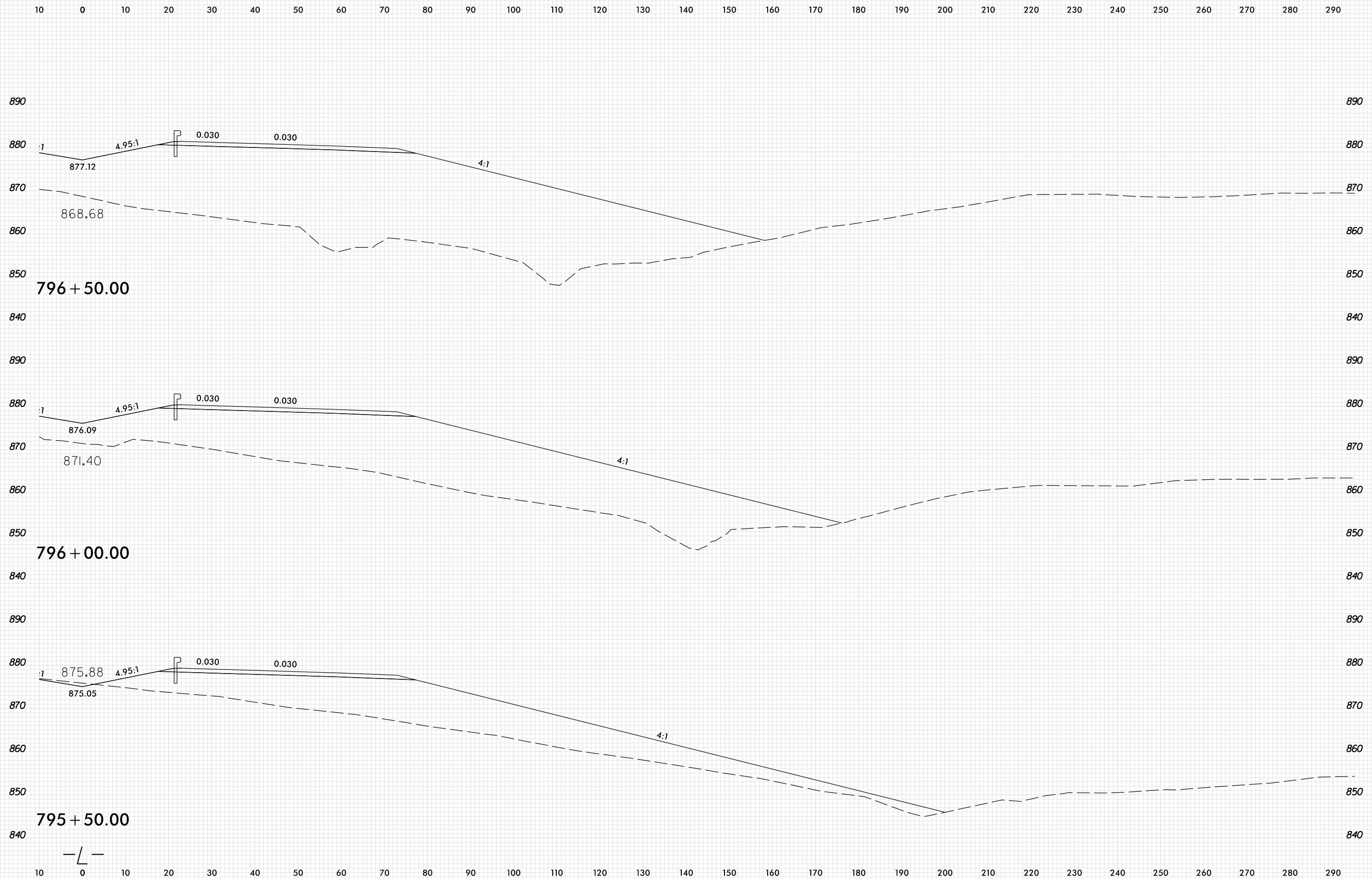

PLOT DRIVER: NCDOT_pdf_color_eng_100.plt
 USER: SPEREIRA
 DATE: 6/10/2021
 TIME: 2:18:15 PM
 FILE: \

8/23/99

0 5 10	PROJ. REFERENCE NO.	SHEET NO.
	U-2579AB	X-151

10 0 10 20 30 40 50 60 70 80 90 100 110 120 130 140 150 160 170 180 190 200 210 220 230 240 250 260 270 280 290

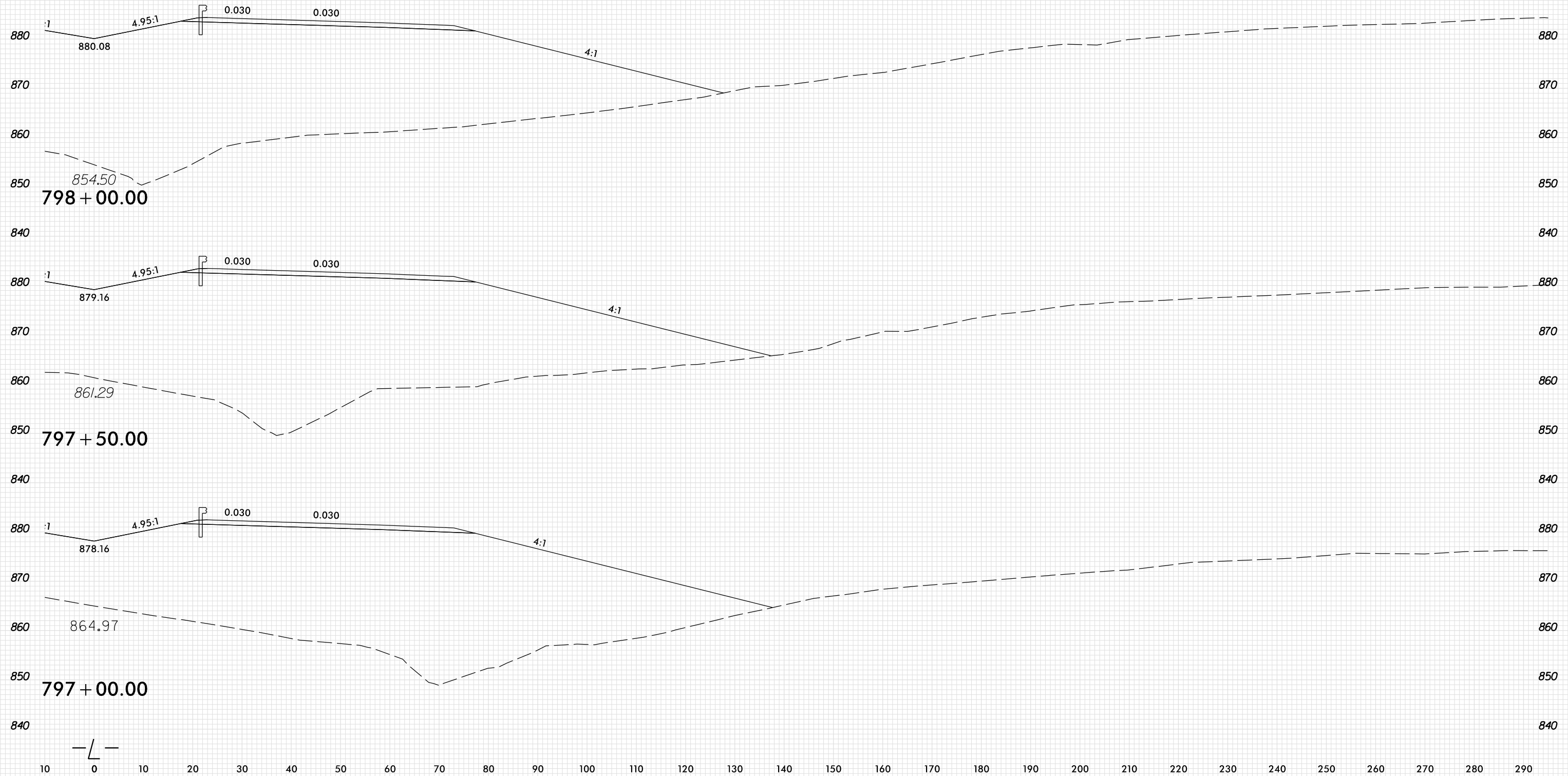

PLOT DRIVER: NCD01_.pdf_color_eng_100.plt
 USER: SPEREIRA
 DATE: 6/10/2021
 TIME: 2:18:16 PM
 FILE: \

8/23/99

0 5 10	PROJ. REFERENCE NO.	SHEET NO.
	U-2579AB	X-152

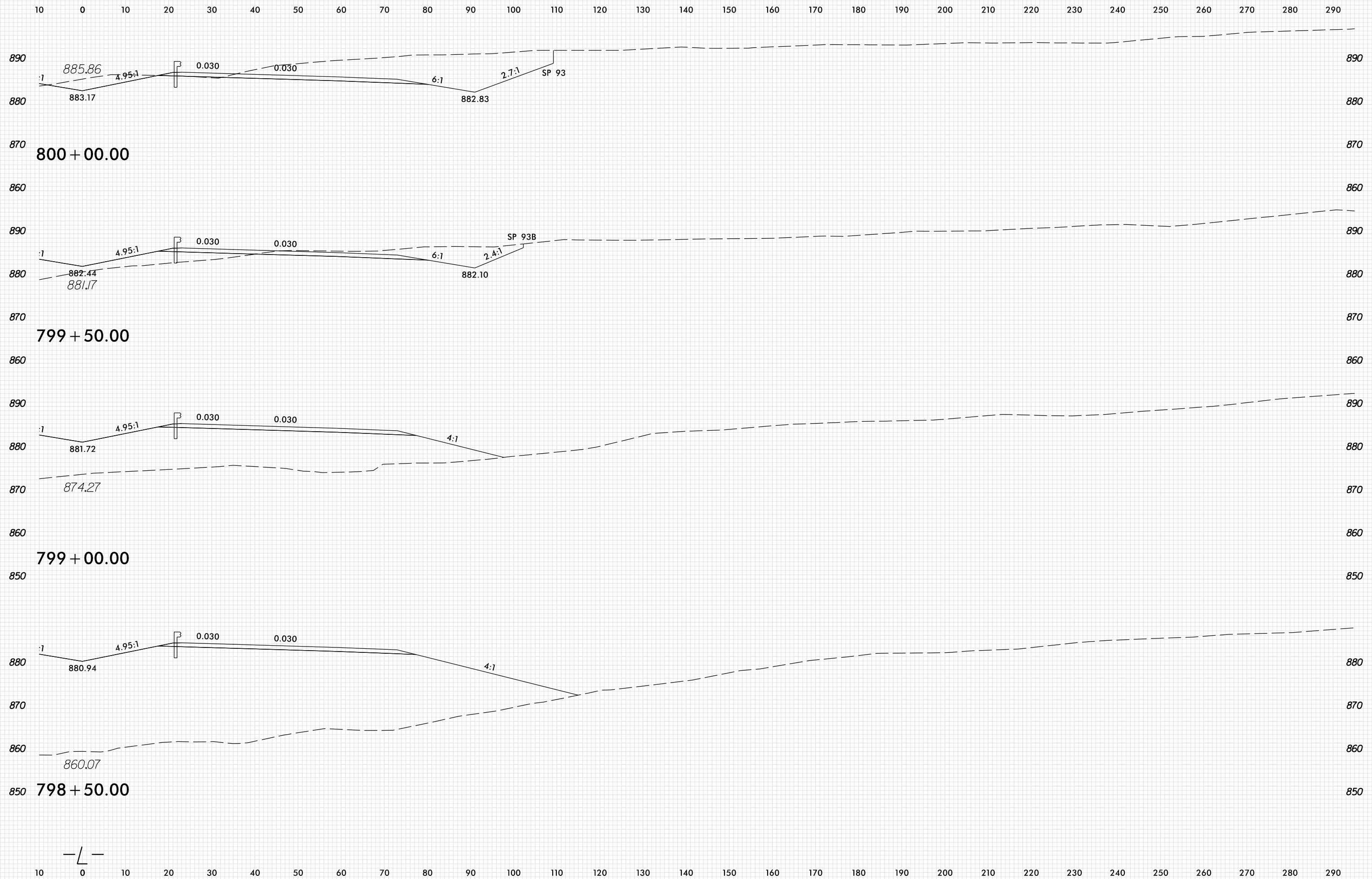

PLOT DRIVER: NCDOT_pdf_color_eng_100.plt
 USER: SPEREIRA
 DATE: 6/10/2021
 TIME: 2:18:17 PM
 FILE: \

8/23/99

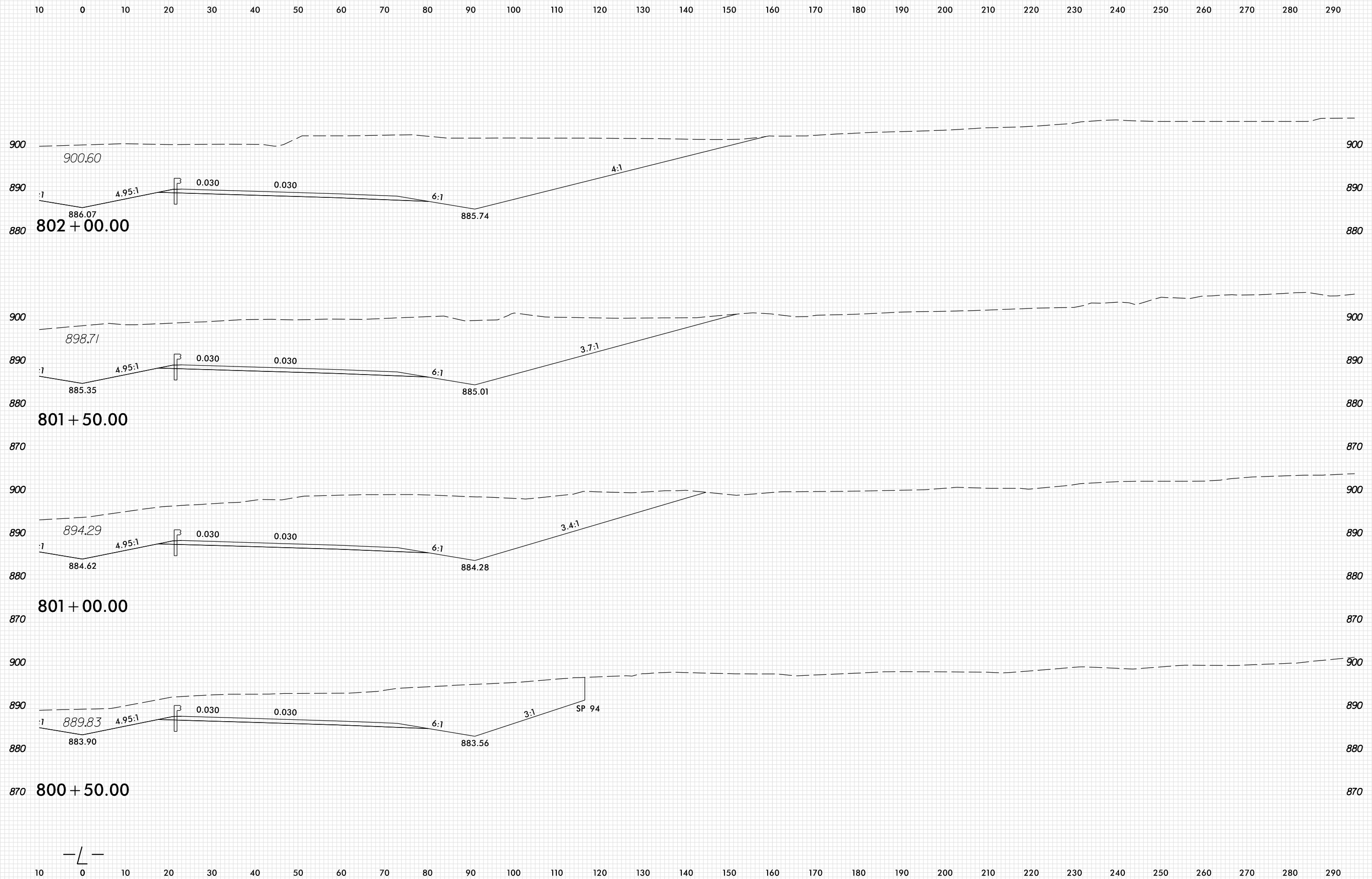

PLOT DRIVER: NCDOT_pdf_color_eng_100.plt
 USER: SPEREIRA
 DATE: 6/10/2021
 TIME: 2:18:17 PM
 FILE: \

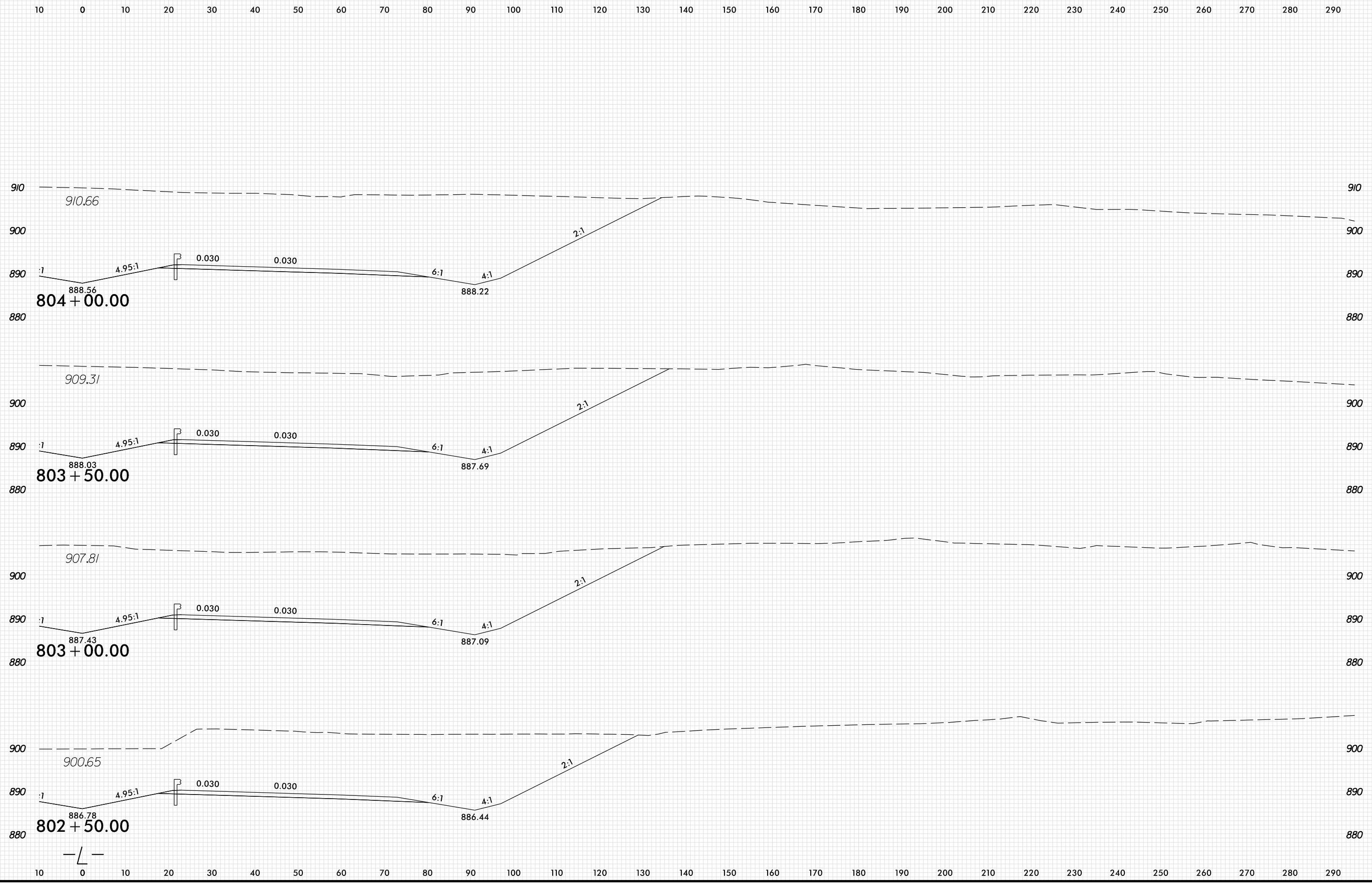

8/23/99

0 5 10	PROJ. REFERENCE NO.	SHEET NO.
	U-2579AB	X-155

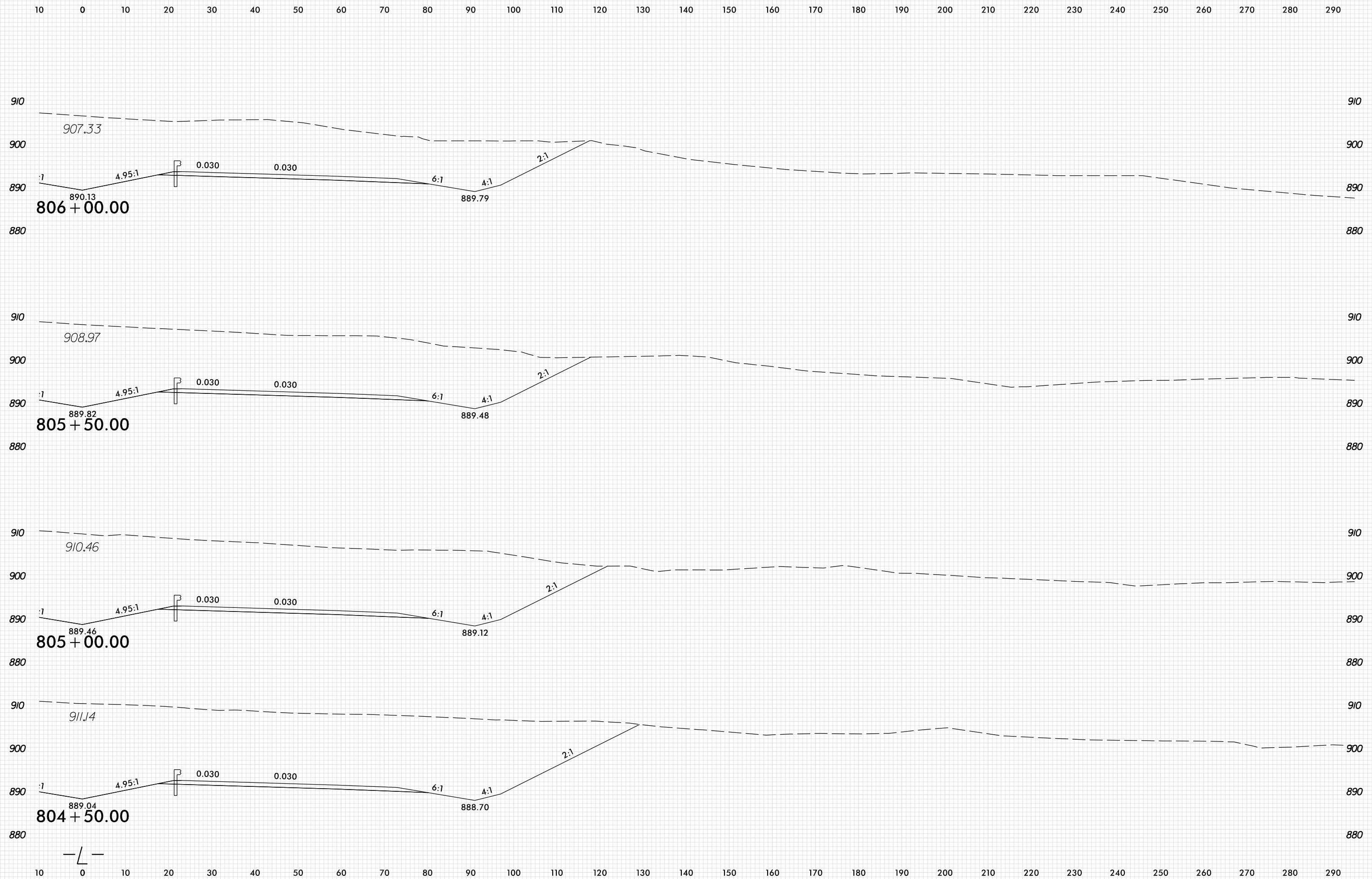

PLOT DRIVER: NCD01_pdf_color_eng_100.plt
 USER: SPEREIRA
 DATE: 6/10/2021
 TIME: 2:18:19 PM
 FILE: \

8/23/99

0 5 10	PROJ. REFERENCE NO.	SHEET NO.
	U-2579AB	X-156

10 0 10 20 30 40 50 60 70 80 90 100 110 120 130 140 150 160 170 180 190 200 210 220 230 240 250 260 270 280 290

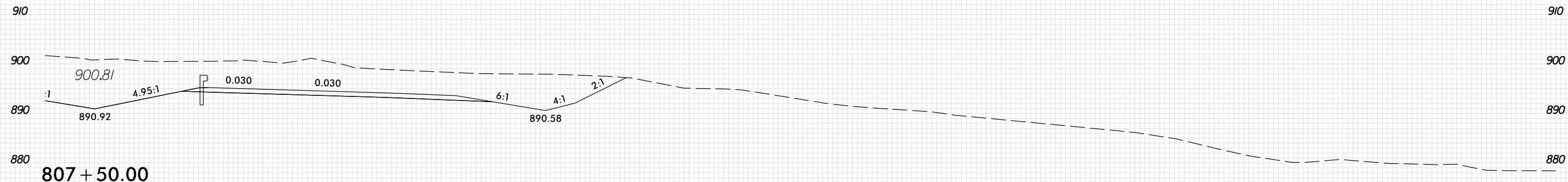

807 + 50.00

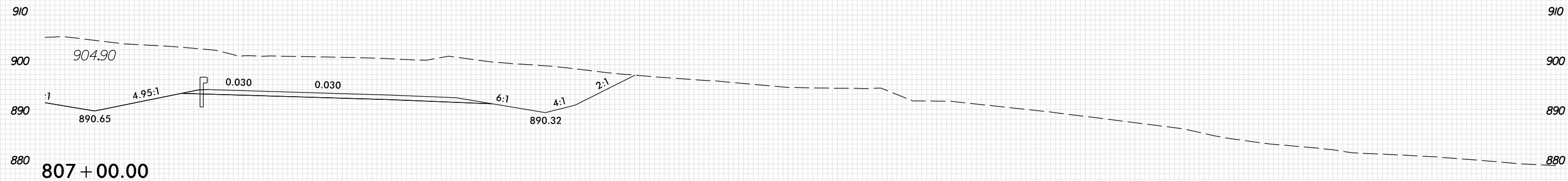

807 + 00.00

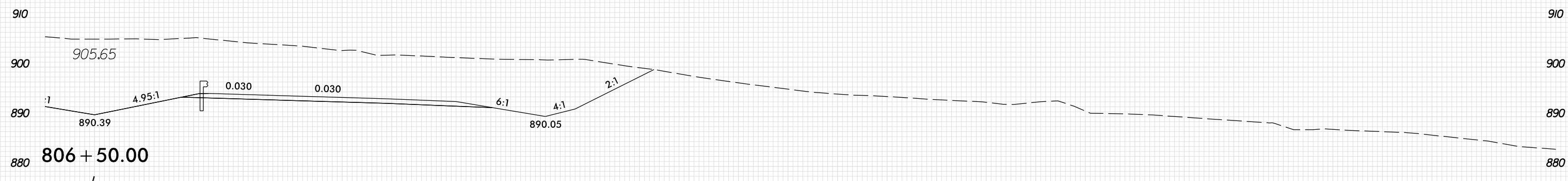

806 + 50.00

10 0 10 20 30 40 50 60 70 80 90 100 110 120 130 140 150 160 170 180 190 200 210 220 230 240 250 260 270 280 290

PLOT DRIVER: NCDOT_pdf_color_eng_100.plt
 USER: SPEREIRA
 DATE: 6/10/2021
 TIME: 2:18:19 PM
 FILE: \

8/23/99

0 5 10	PROJ. REFERENCE NO.	SHEET NO.
	U-2579AB	X-157

10 0 10 20 30 40 50 60 70 80 90 100 110 120 130 140 150 160 170 180 190 200 210 220 230 240 250 260 270 280 290

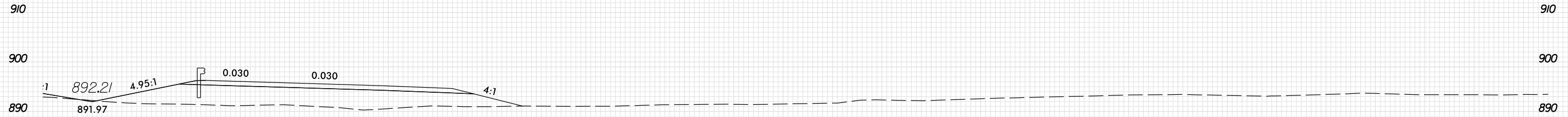

809 + 50.00

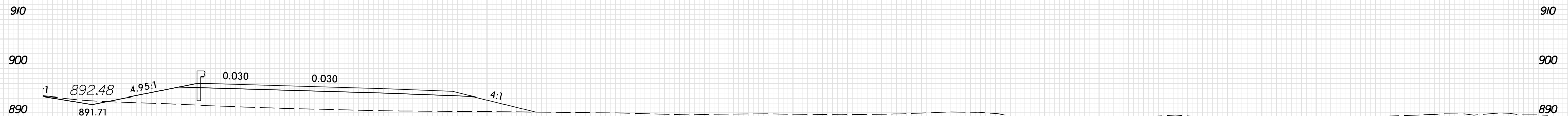

809 + 00.00

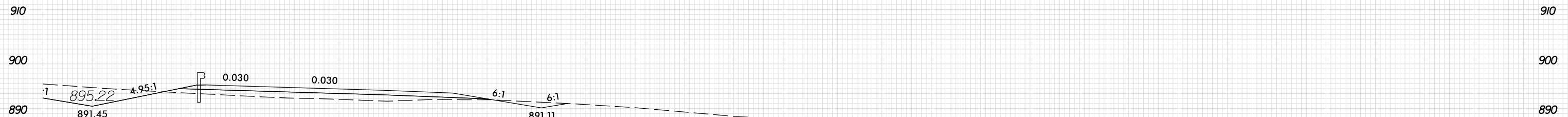

808 + 50.00

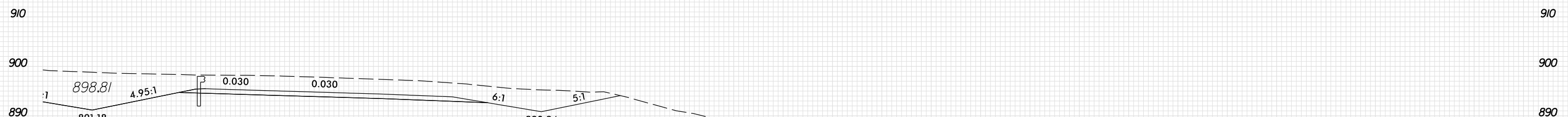

808 + 00.00

10 0 10 20 30 40 50 60 70 80 90 100 110 120 130 140 150 160 170 180 190 200 210 220 230 240 250 260 270 280 290

PLOT DRIVER: NCDOT_pdf_color_eng_100.plt
USER: SPEREIRA
DATE: 6/10/2021
TIME: 2:16:20 PM
FILE: \



8/23/99

10 0 10 20 30 40 50 60 70 80 90 100 110 120 130 140 150 160 170 180 190 200 210 220 230 240 250 260 270 280 290

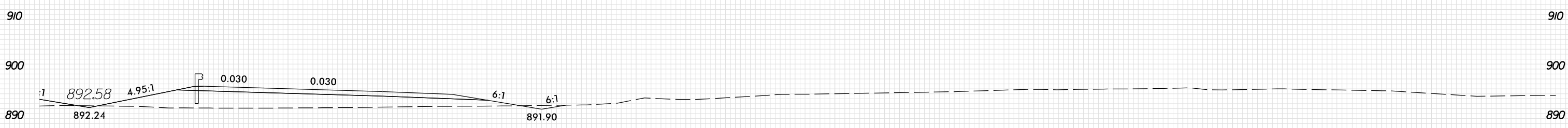
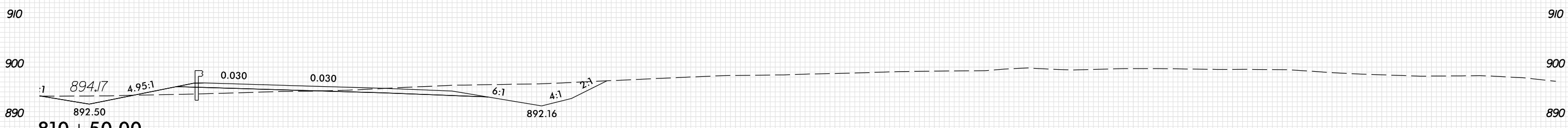
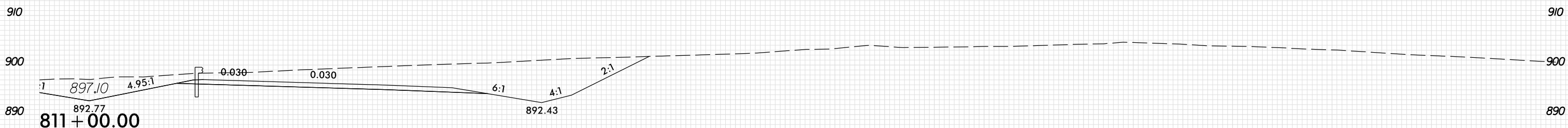
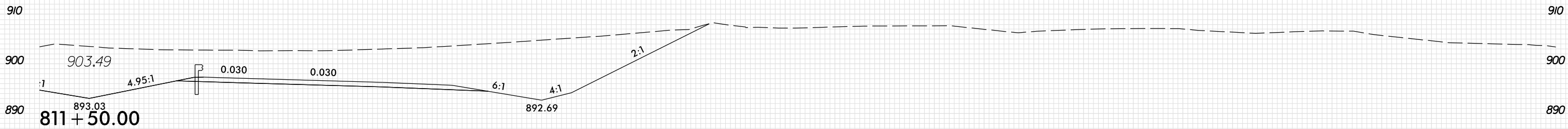

10 0 10 20 30 40 50 60 70 80 90 100 110 120 130 140 150 160 170 180 190 200 210 220 230 240 250 260 270 280 290

PLOT DRIVER: NCD01_pdf_color_eng_100.plt
USER: SPEREIRA
DATE: 6/10/2021
TIME: 2:16:22 PM
FILE: \

8/23/99

0 5 10	PROJ. REFERENCE NO.	SHEET NO.
	U-2579AB	X-159

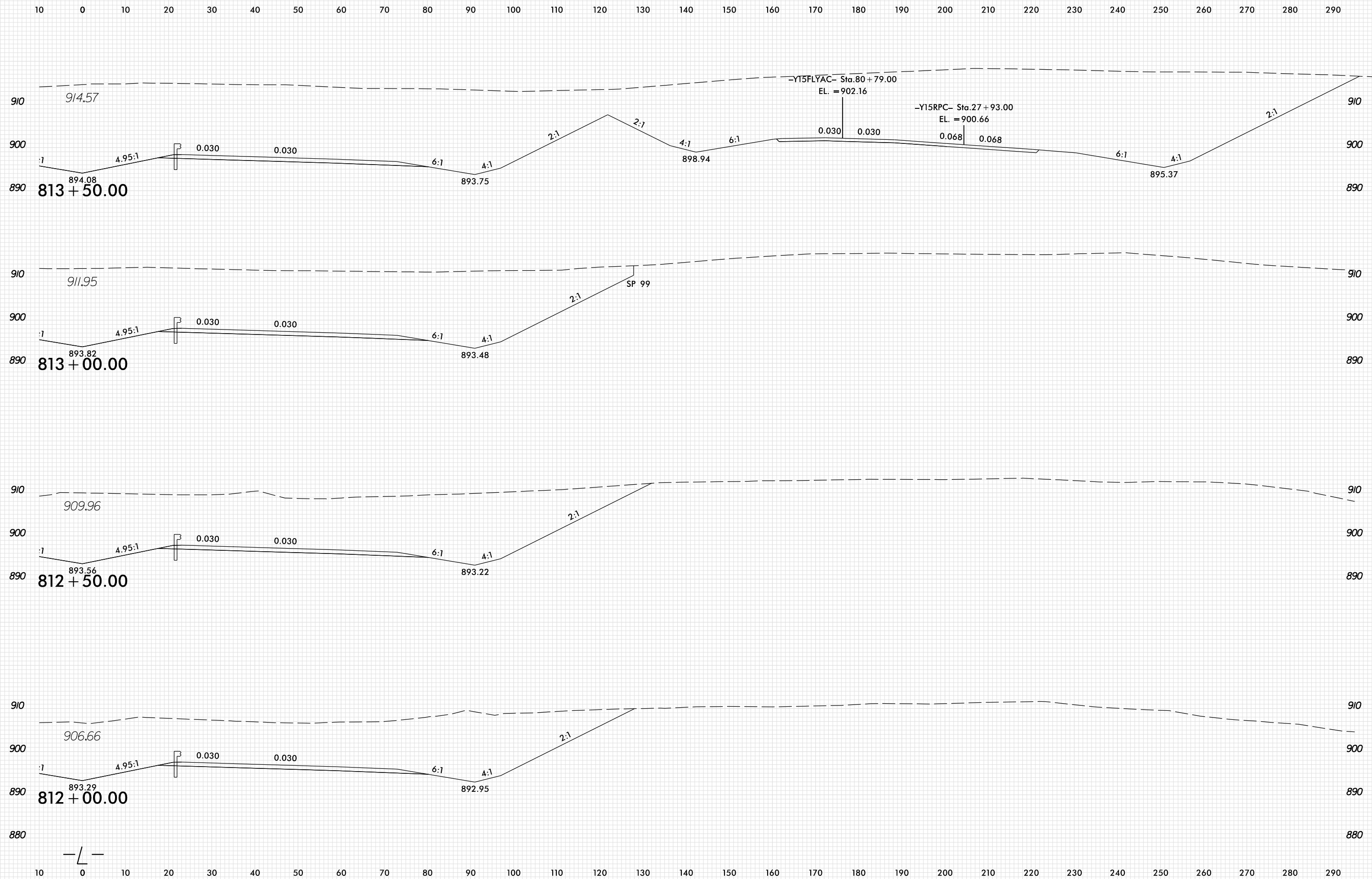

PLOT DRIVER: NCDOT_pdf_color_eng_100.plt
 USER: SPEREIRA
 DATE: 6/10/2021
 TIME: 2:16:22 PM
 FILE: \

8/23/99

10 0 10 20 30 40 50 60 70 80 90 100 110 120 130 140 150 160 170 180 190 200 210 220 230 240 250 260 270 280 290

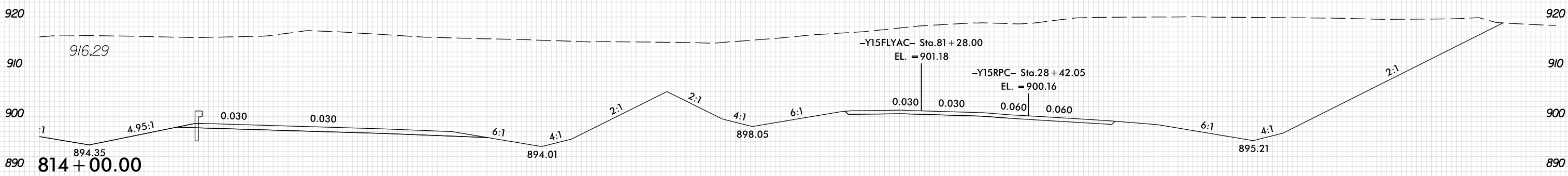
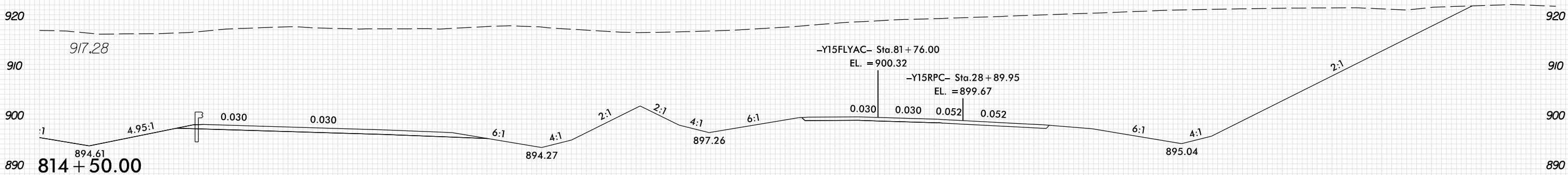
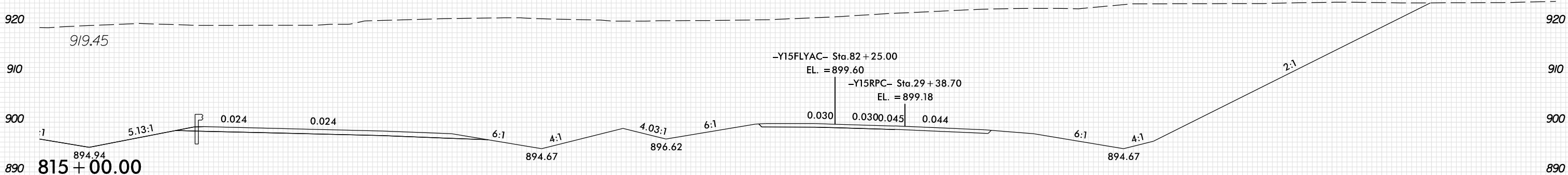

10 0 10 20 30 40 50 60 70 80 90 100 110 120 130 140 150 160 170 180 190 200 210 220 230 240 250 260 270 280 290

PLOT DRIVER: NCD01_pdf_color_eng_100.plt
USER: SPEREIRA
DATE: 6/10/2021
TIME: 2:16:23 PM
FILE: \

10 0 10 20 30 40 50 60 70 80 90 100 110 120 130 140 150 160 170 180 190 200 210 220 230 240 250 260 270 280 290

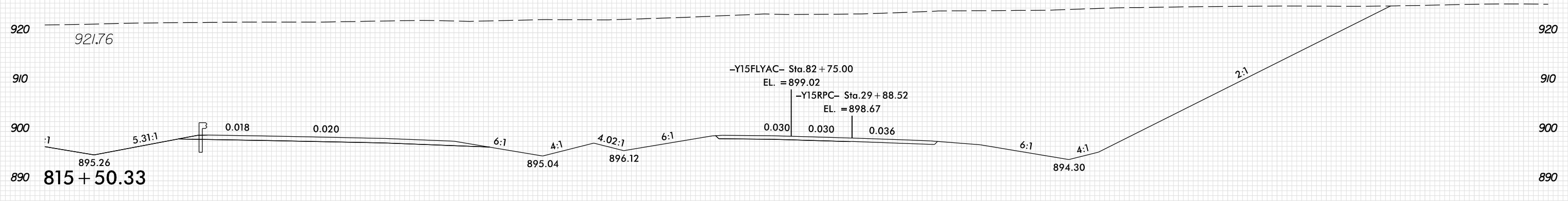
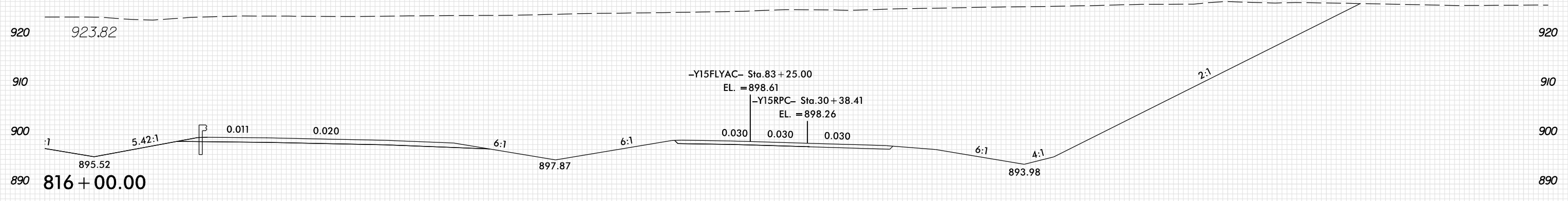
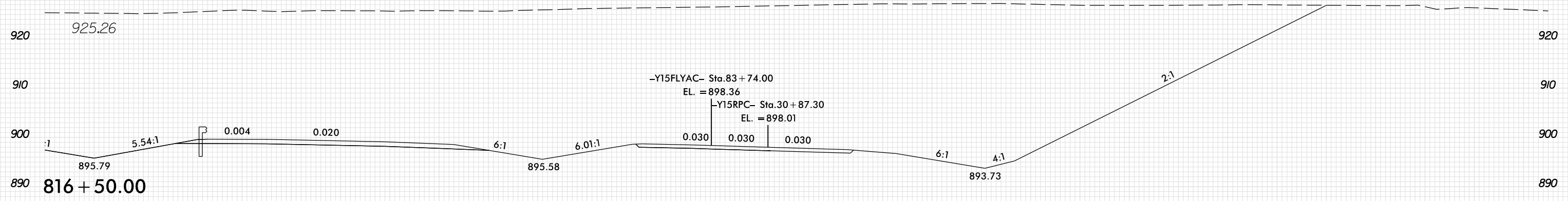

10 0 10 20 30 40 50 60 70 80 90 100 110 120 130 140 150 160 170 180 190 200 210 220 230 240 250 260 270 280 290

8/23/99

10 0 10 20 30 40 50 60 70 80 90 100 110 120 130 140 150 160 170 180 190 200 210 220 230 240 250 260 270 280 290

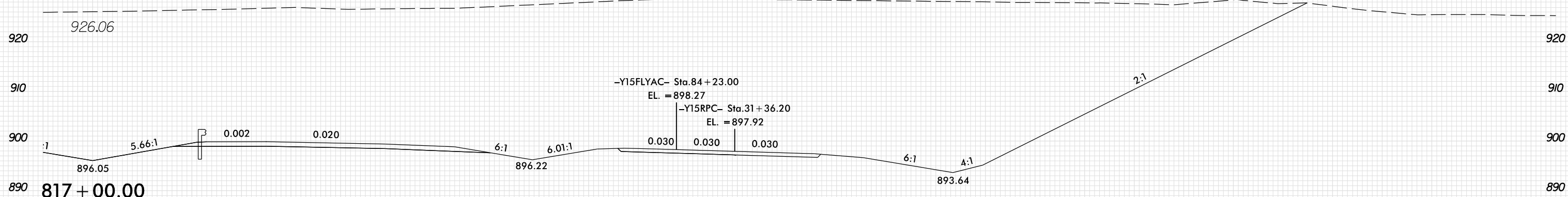
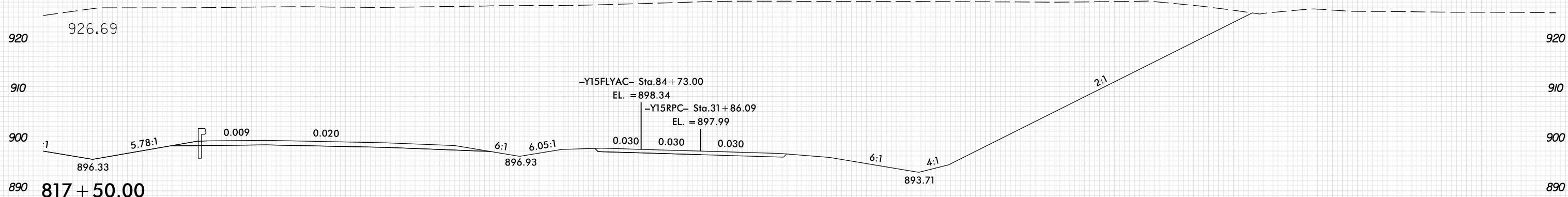
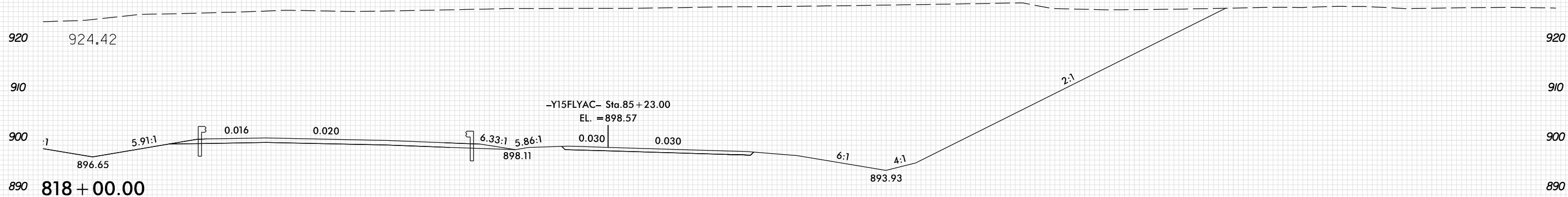

10 0 10 20 30 40 50 60 70 80 90 100 110 120 130 140 150 160 170 180 190 200 210 220 230 240 250 260 270 280 290

PLOT DRIVER: NCD01...pdf_color_eng_100.plt
USER: SPEREIRA
DATE: 6/10/2021
TIME: 2:18:24 PM

8/23/99

10 0 10 20 30 40 50 60 70 80 90 100 110 120 130 140 150 160 170 180 190 200 210 220 230 240 250 260 270 280 290

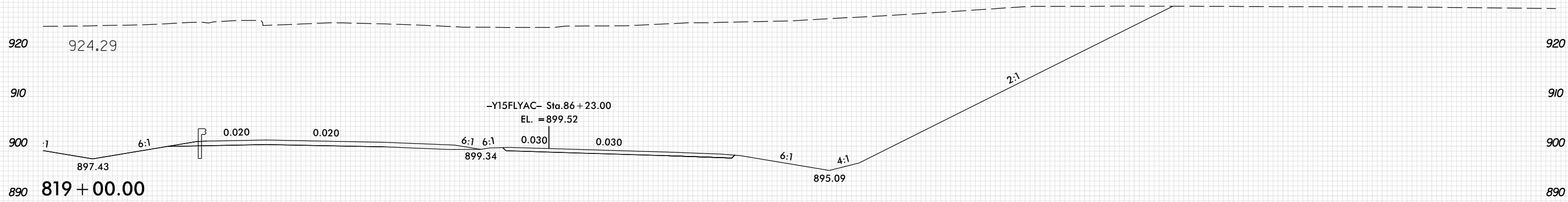
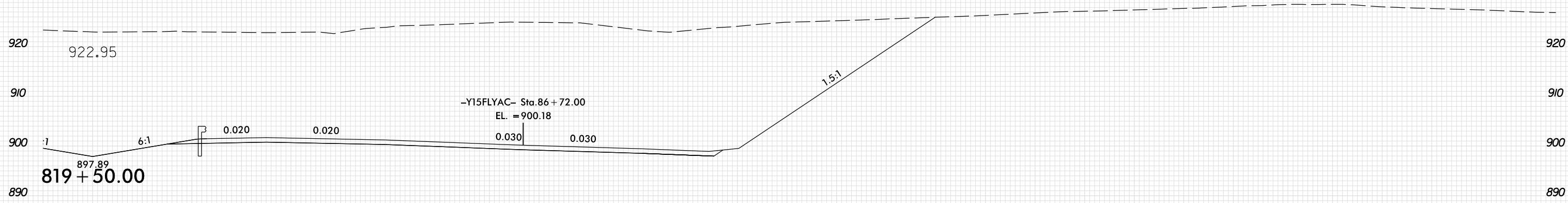

10 0 10 20 30 40 50 60 70 80 90 100 110 120 130 140 150 160 170 180 190 200 210 220 230 240 250 260 270 280 290

PLOT DRIVER: NCD01... PENTABLE: xpl_en_v8.tbl
USER: SPEREIRA DATE: 6/10/2021 TIME: 2:16:25 PM
FILE: \

8/23/99

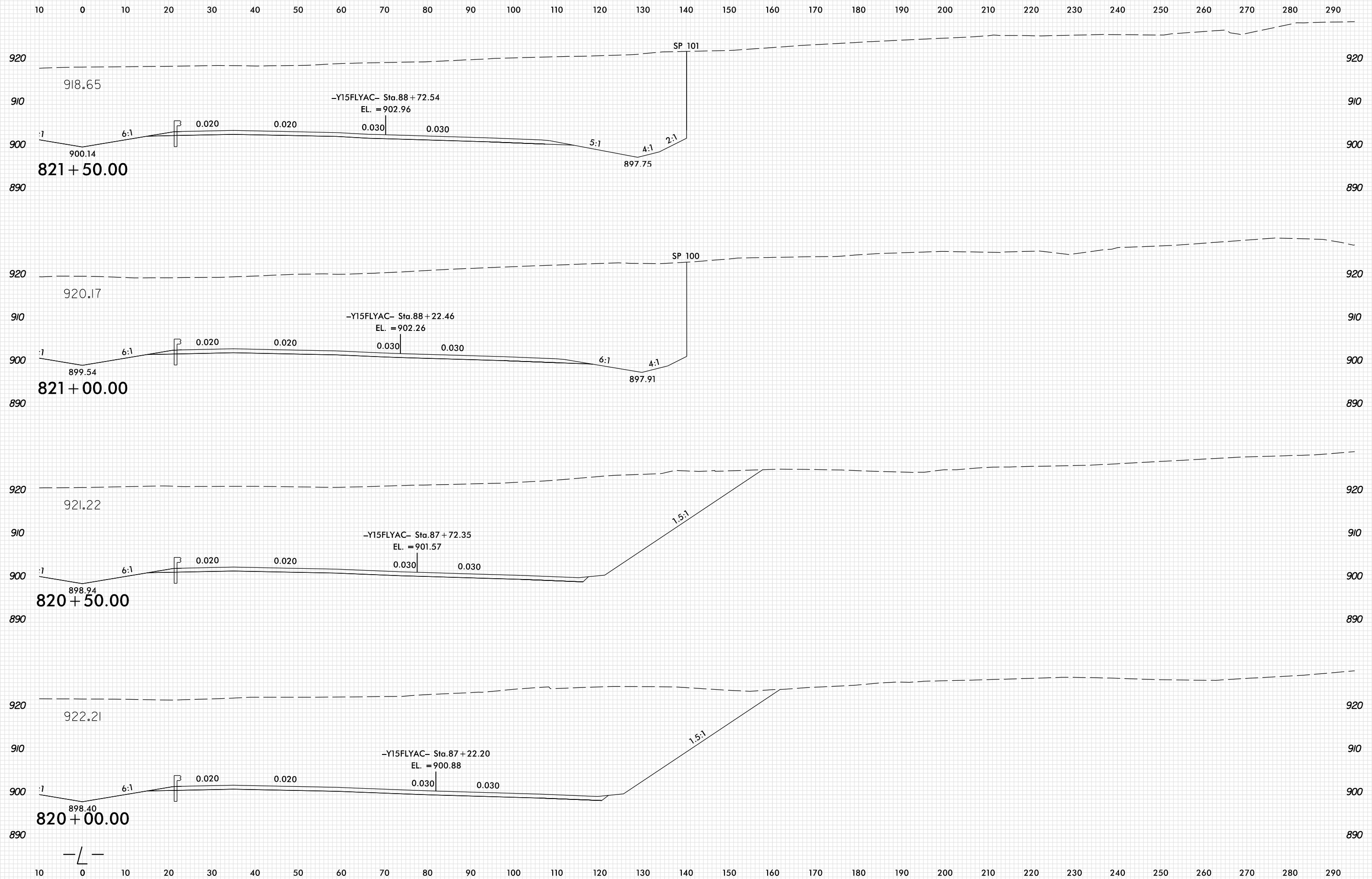

PLOT DRIVER: NCD01.pdf_color_eng_100.plt
 USER: SPEREIRA
 DATE: 6/10/2021
 TIME: 2:16:25 PM
 FILE: \

8/23/99

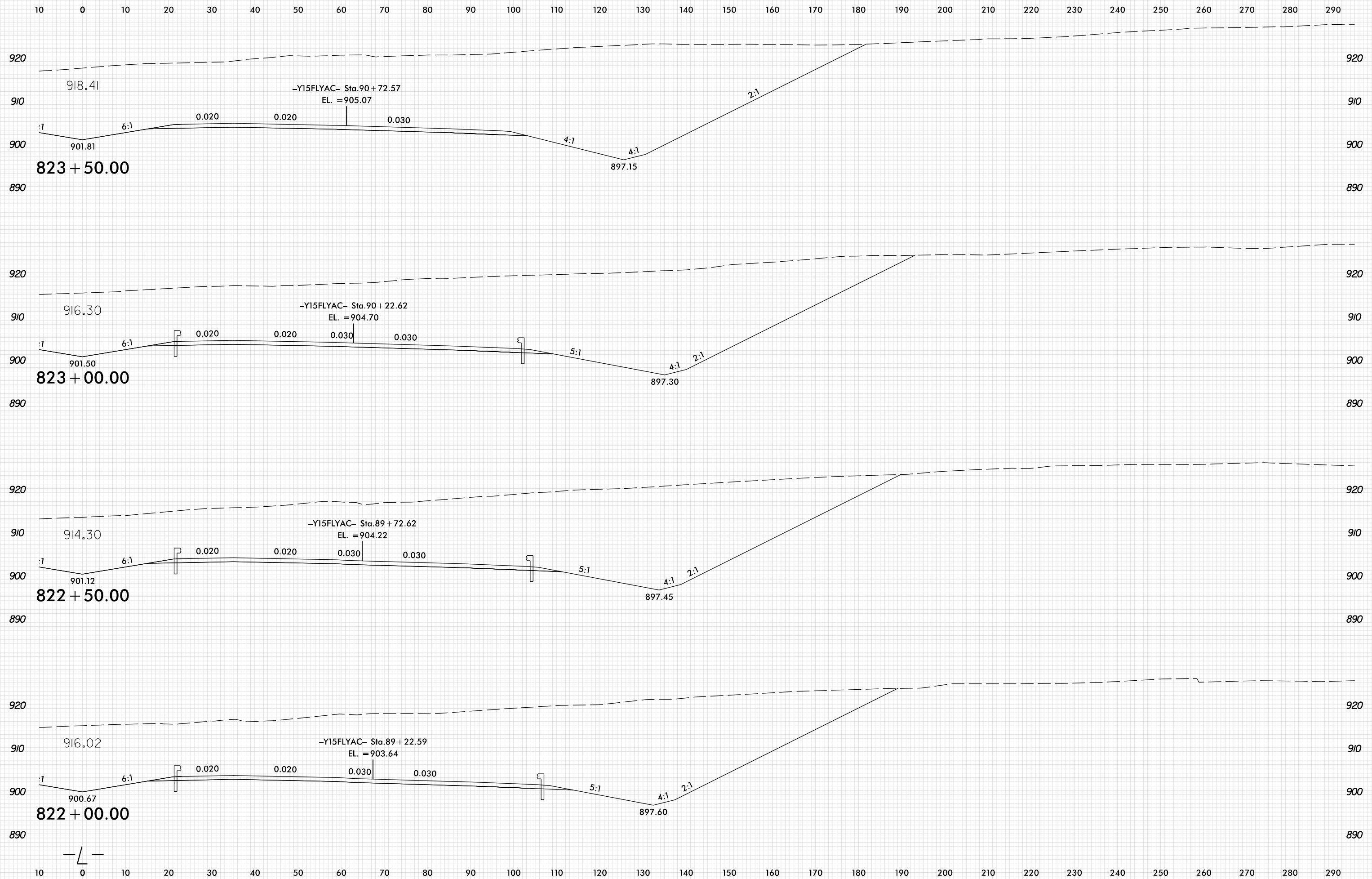

PLOT DRIVER: NCDOT_pdf_color_eng_100.plt
 USER: SPEREIRA
 DATE: 6/10/2021
 TIME: 2:18:26 PM
 FILE: \

8/23/99

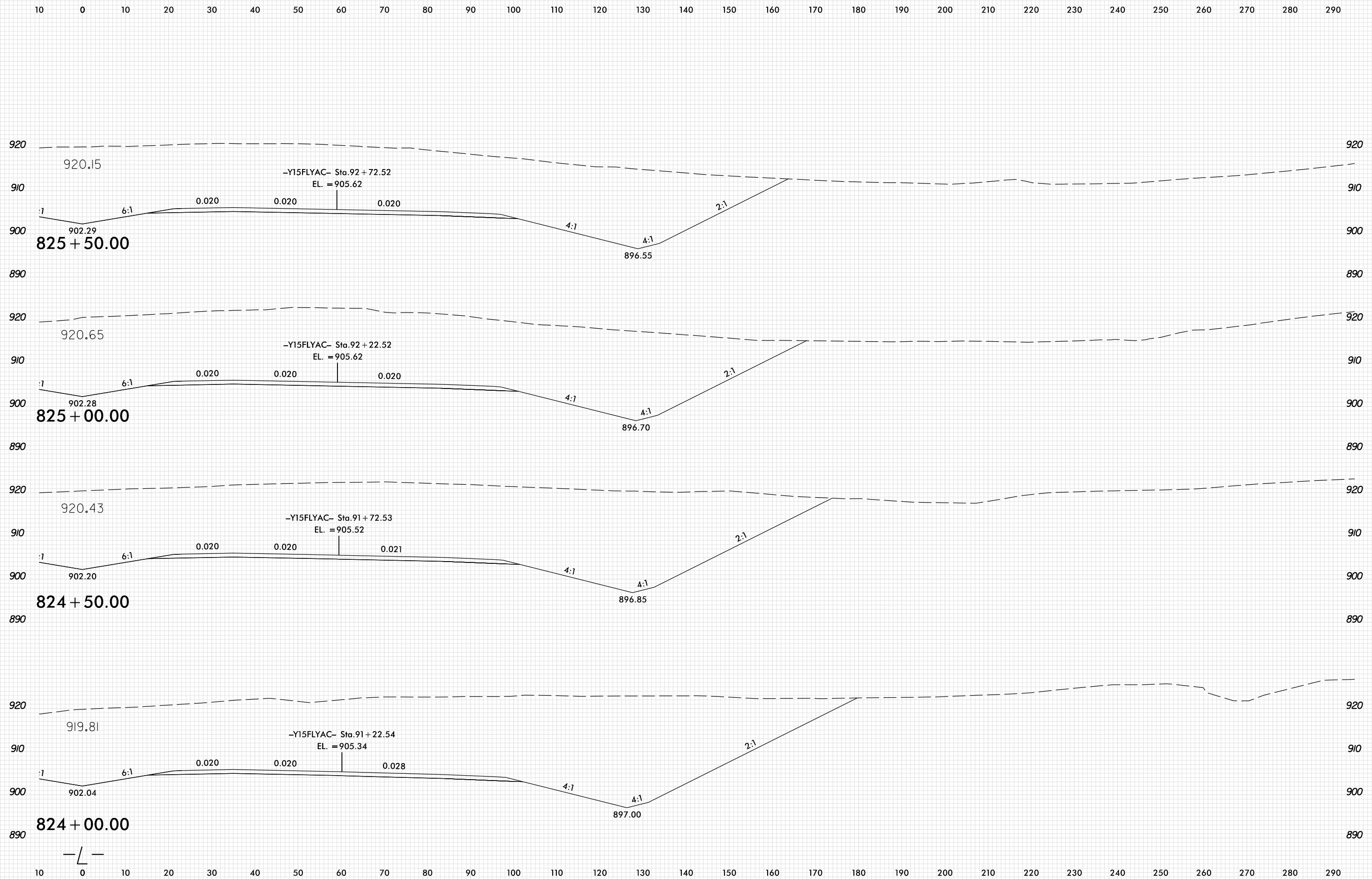

PENTABLE: xpl_en_v8.tb1
 USER: SPEREIRA
 DATE: 6/10/2021
 TIME: 2:16:27 PM
 FILE: \

8/23/99

0 5 10	PROJ. REFERENCE NO.	SHEET NO.
	U-2579AB	X-167

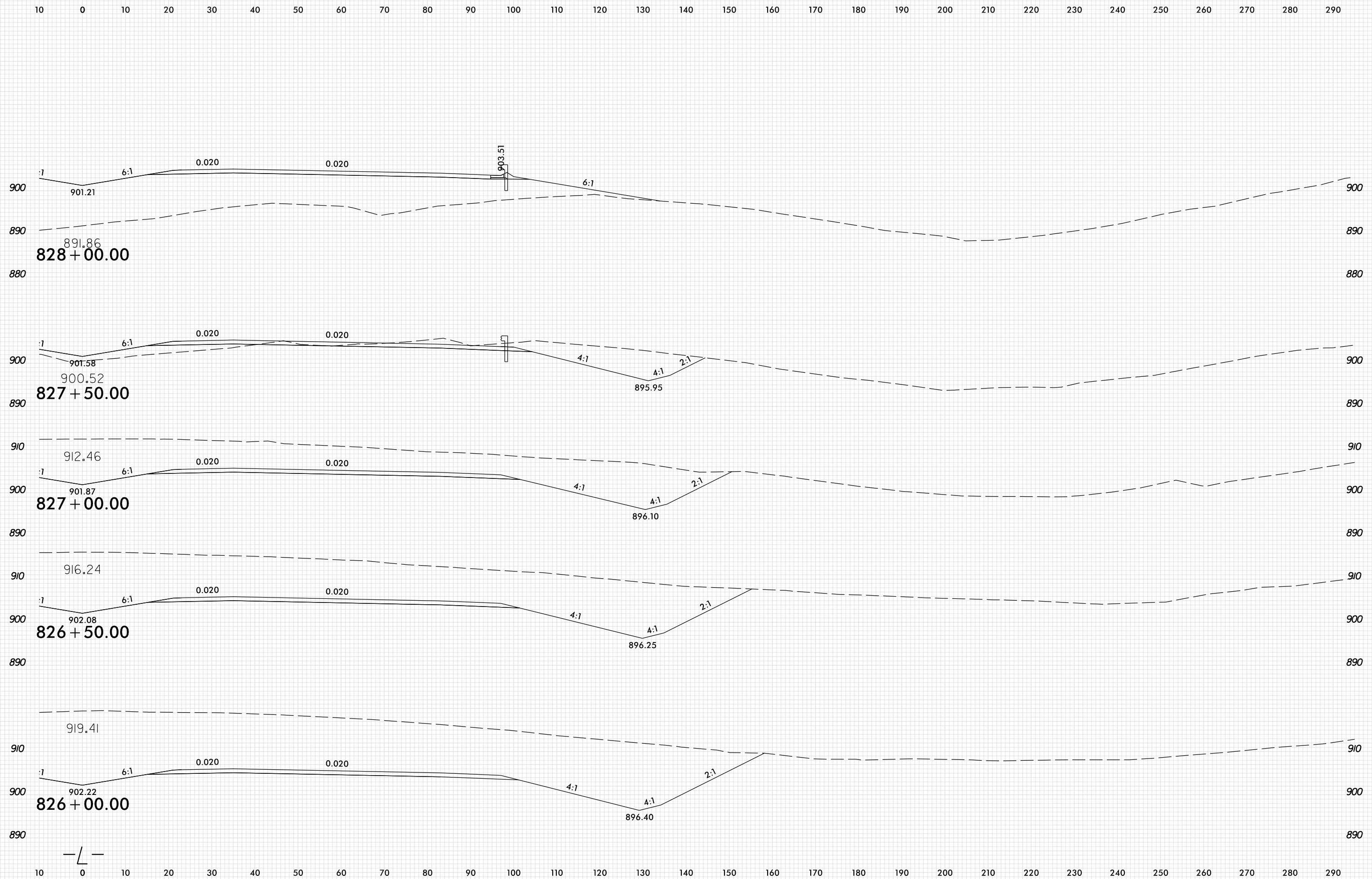

PLOT DRIVER: NCDOT_pdf_color_eng_100.plt
 USER: SPEREIRA
 DATE: 6/10/2021
 TIME: 2:18:27 PM
 FILE: \

8/23/99

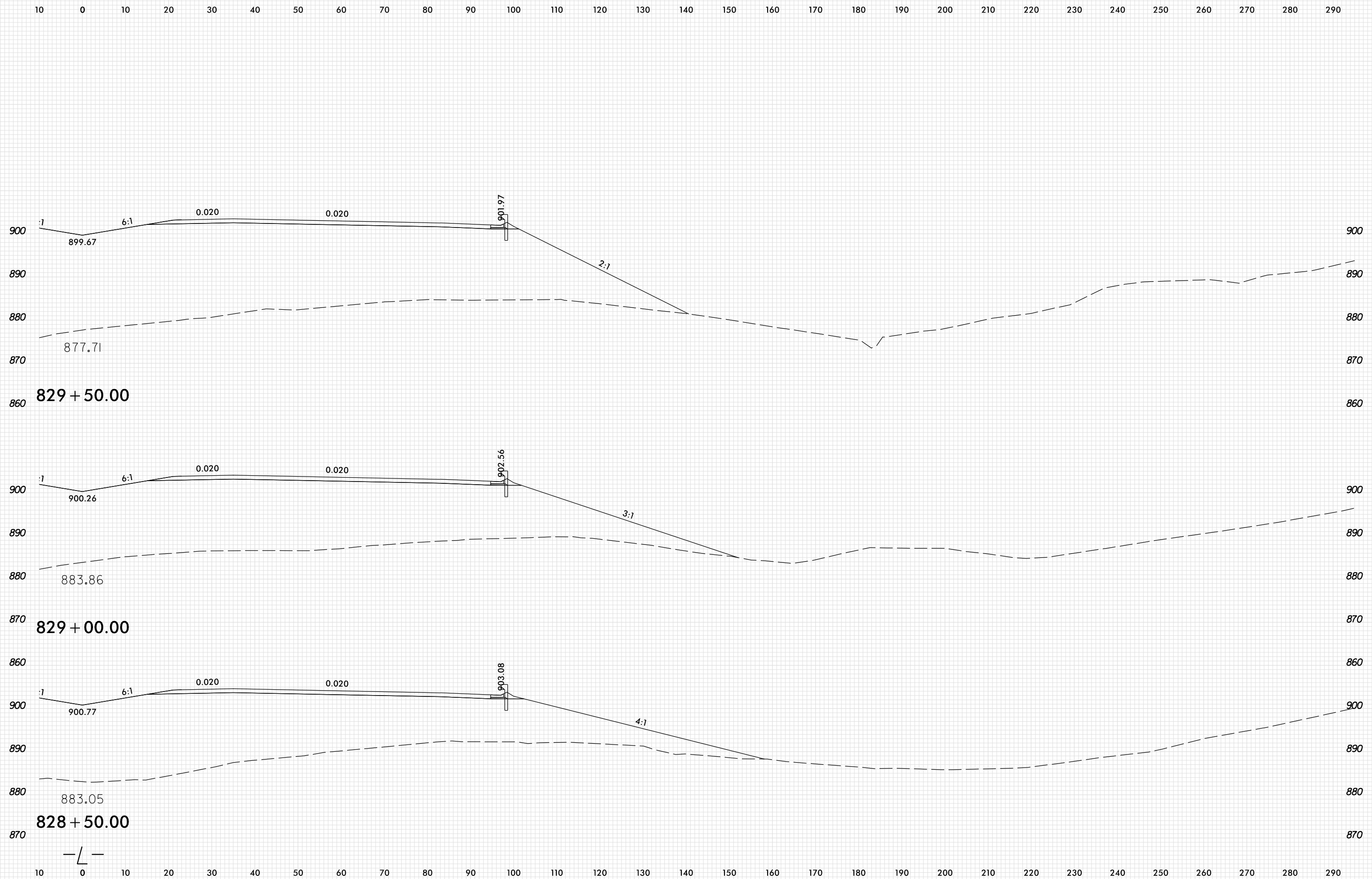

PLOT DRIVER: NCDOT_pdf_color_eng_100.plt
 USER: SPEREIRA
 DATE: 6/10/2021
 TIME: 2:16:28 PM
 FILE: \

8/23/99

10 0 10 20 30 40 50 60 70 80 90 100 110 120 130 140 150 160 170 180 190 200 210 220 230 240 250 260 270 280 290

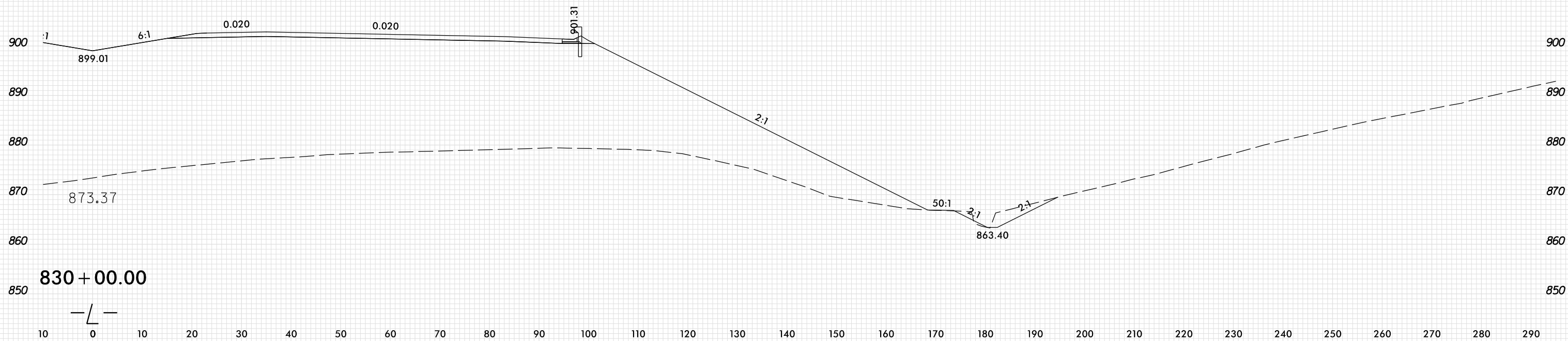
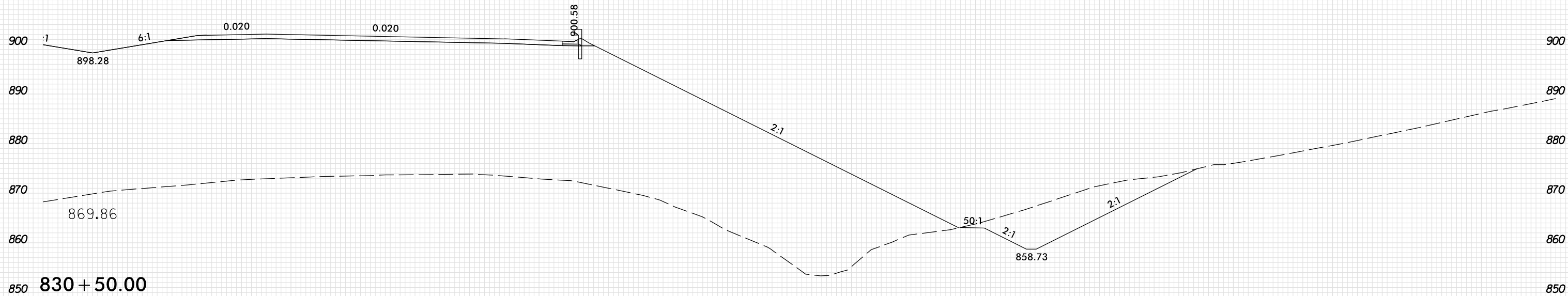

PLOT DRIVER: NCD01.pdf_color_eng_100.plt
 USER: SPEREIRA
 DATE: 6/10/2021
 TIME: 2:18:29 PM
 FILE: \

8/23/99

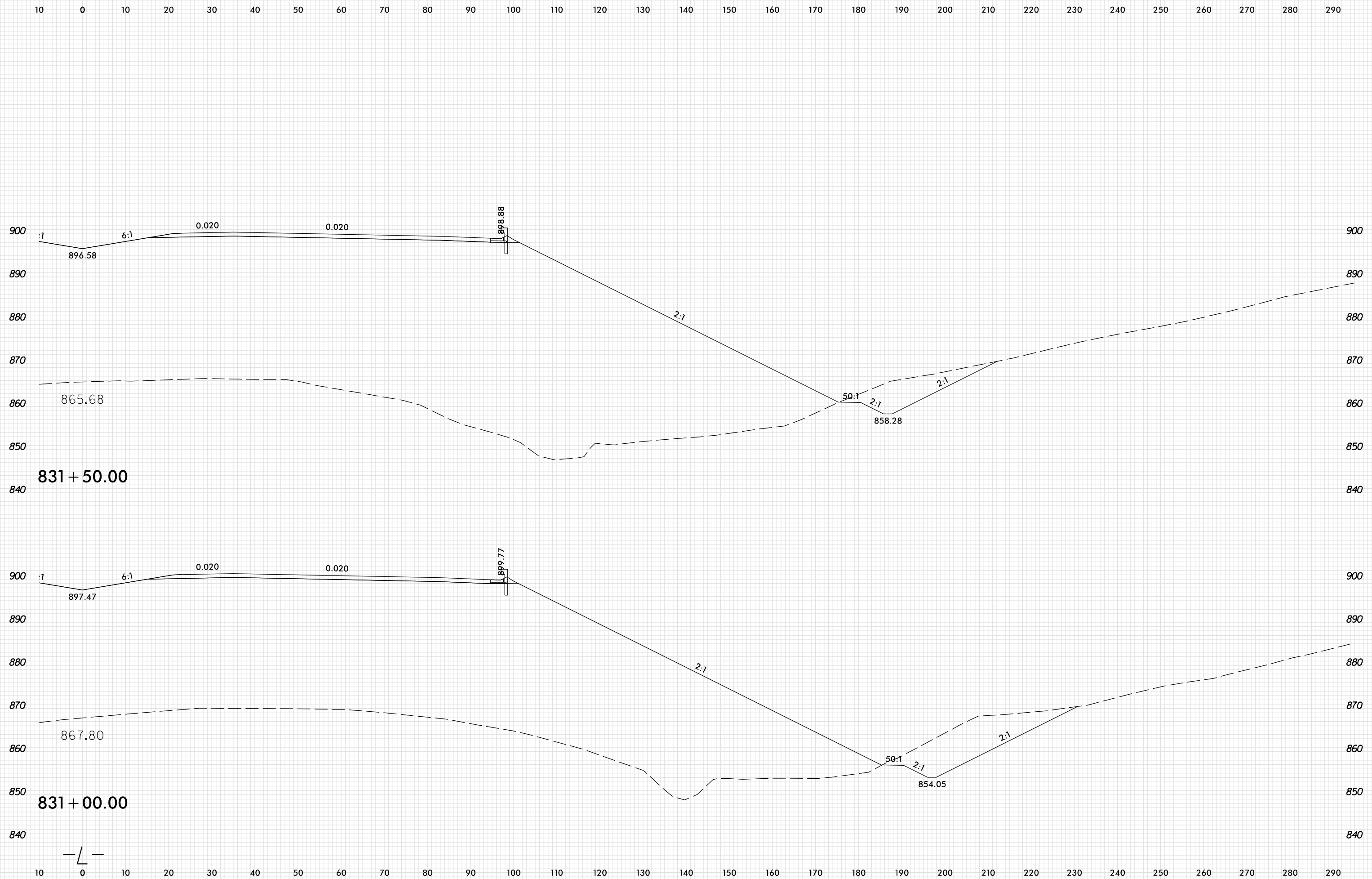

PLOT DRIVER: NCDOT_pdf_color_eng_100.plt
 USER: SPEREIRA
 DATE: 6/10/2021
 TIME: 2:16:29 PM
 FILE: \



8/23/99

0 5 10	PROJ. REFERENCE NO.	SHEET NO.
	U-2579AB	X-171

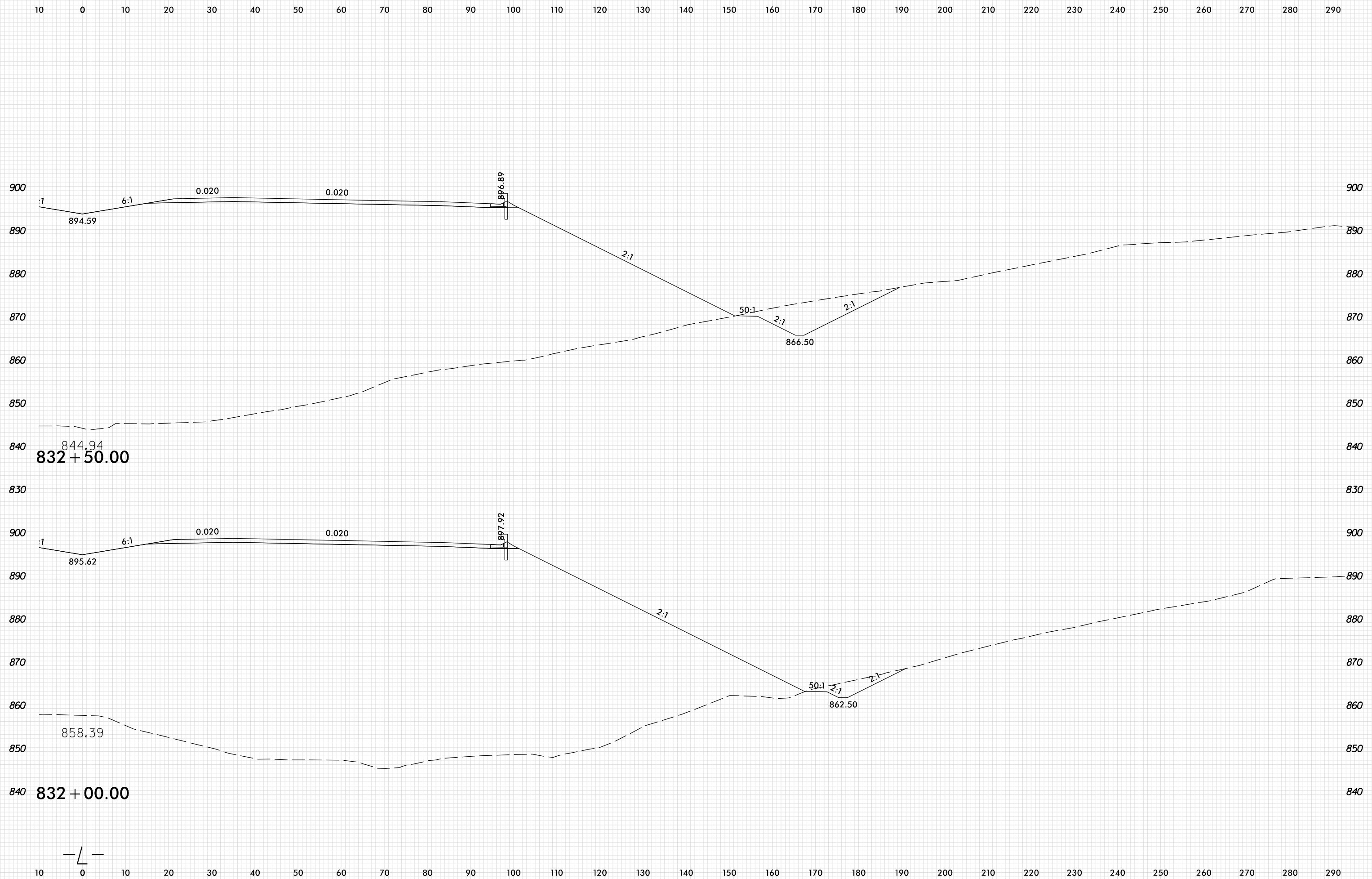

PLOT DRIVER: NCDOT_pdf_color_eng_100.plt
 USER: SPEREIRA
 DATE: 6/10/2021
 TIME: 2:18:30 PM
 FILE: \



8/23/99

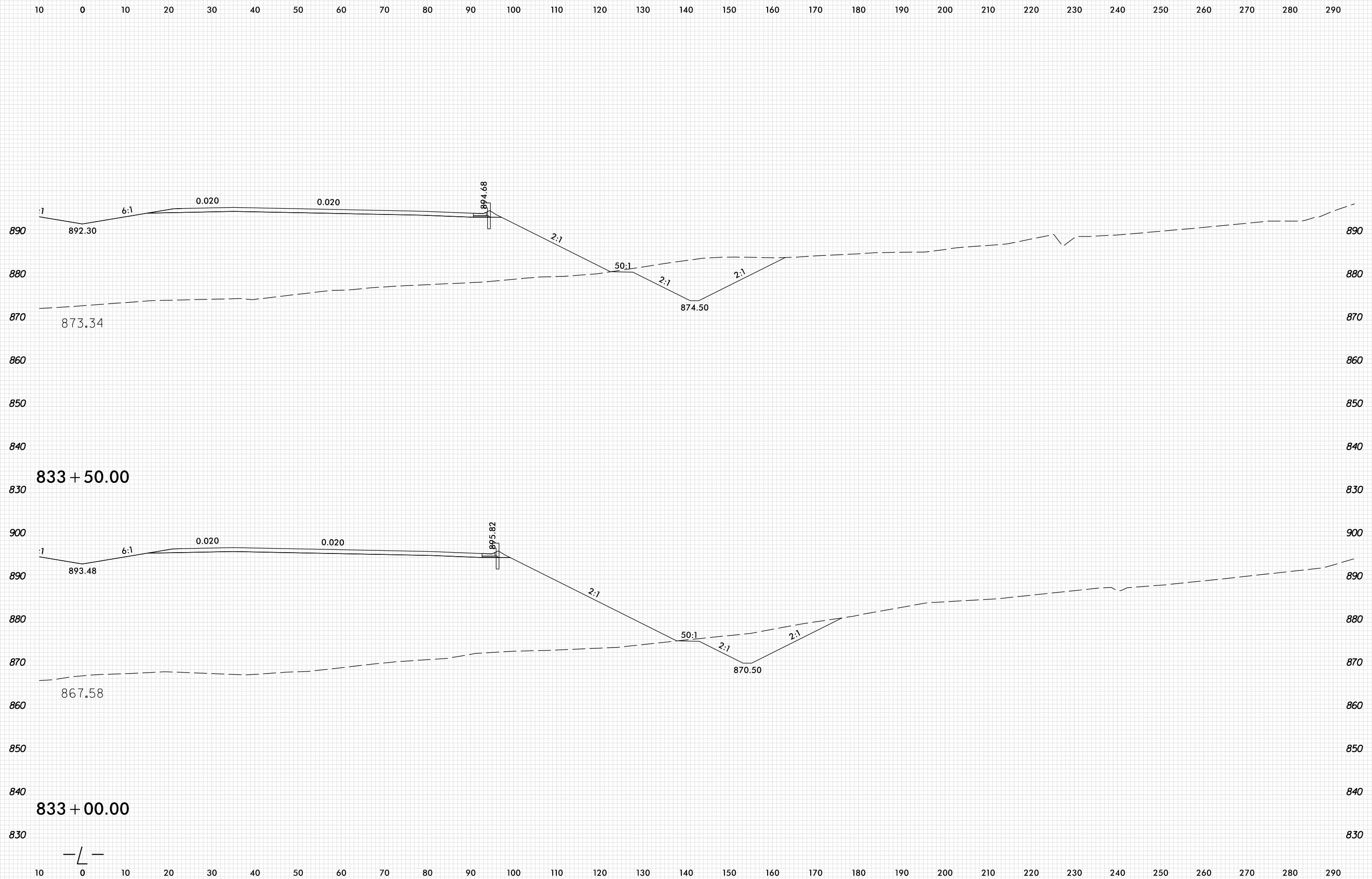

PLOT DRIVER: NCDOT_pdf_color_eng_100.plt
 USER: SPEREIRA
 DATE: 6/10/2021
 TIME: 2:18:30 PM
 FILE: \

8/23/99

0 5 10	PROJ. REFERENCE NO.	SHEET NO.
	U-2579AB	X-172A

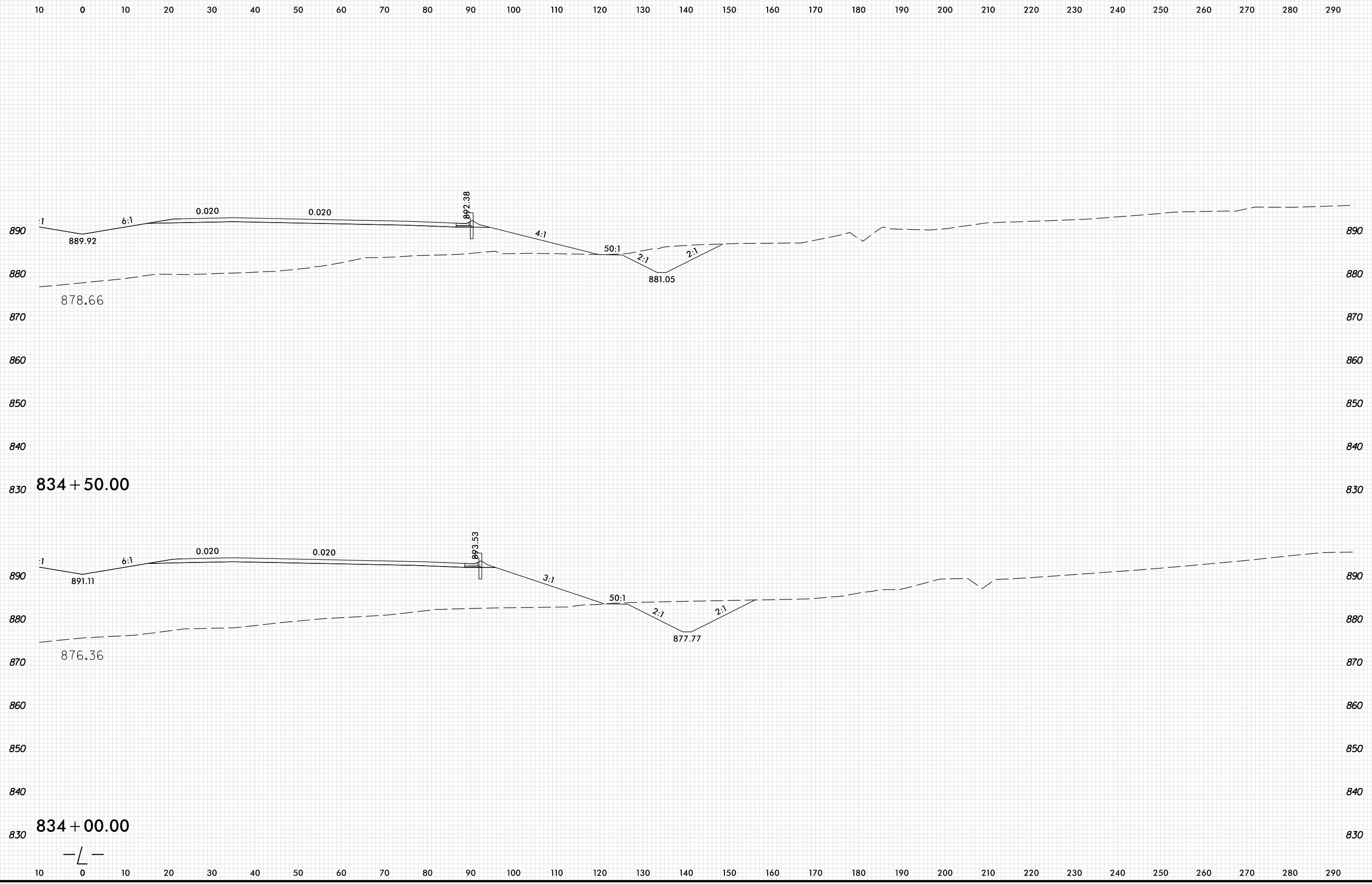

PLOT DRIVER: NCD01_pdf_color_eng_100.plt
 USER: SPEREIRA
 DATE: 6/10/2021
 TIME: 2:18:31 PM
 FILE: \

8/23/99

0 5 10	PROJ. REFERENCE NO.	SHEET NO.
	U-2579AB	X-172B

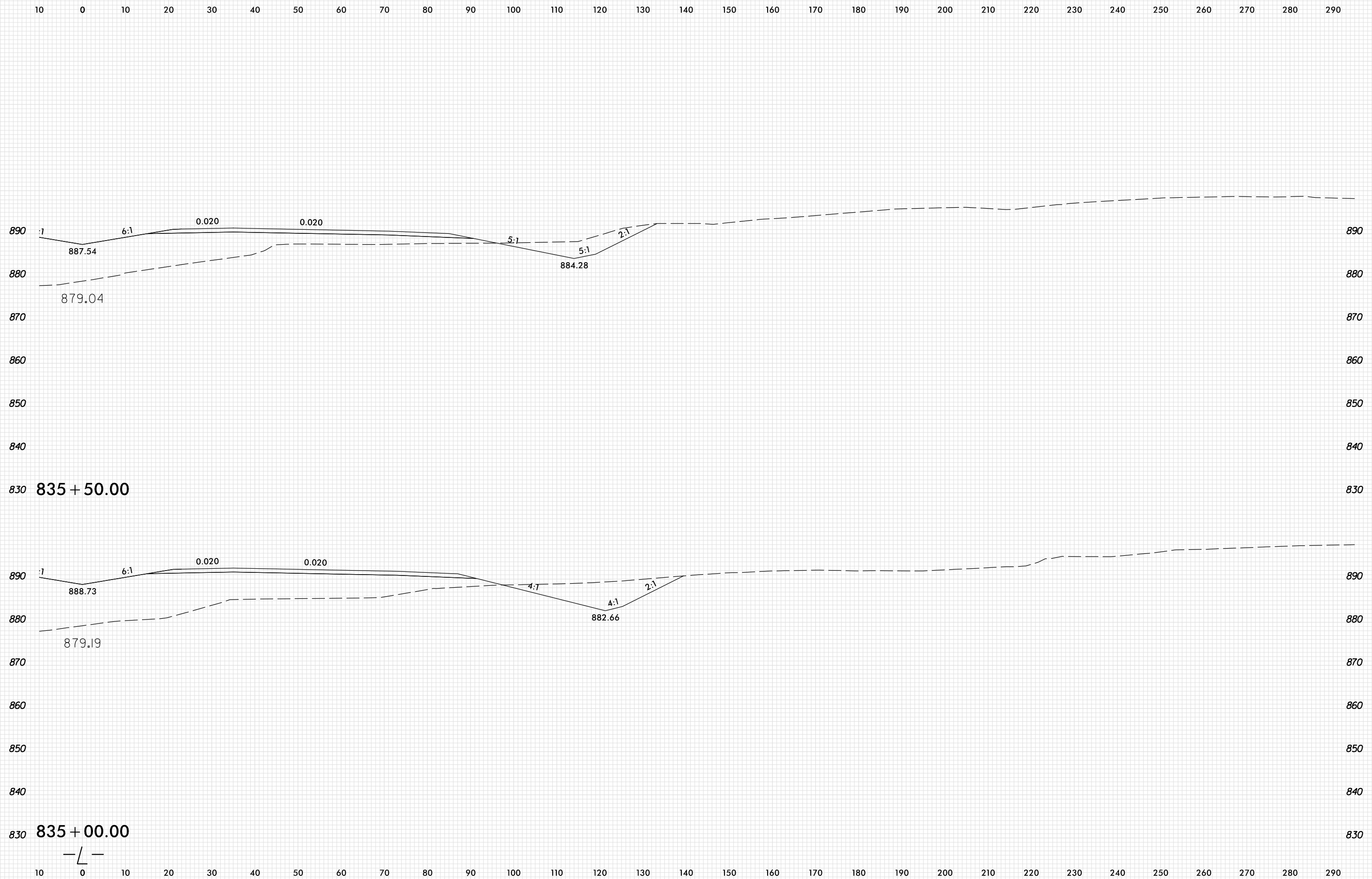

PLOT DRIVER: NCDOT_pdf_color_eng_100.plt
 USER: SPEREIRA
 DATE: 6/10/2021
 TIME: 2:18:32 PM
 FILE: \

8/23/99

0 5 10	PROJ. REFERENCE NO.	SHEET NO.
	U-2579AB	X-172C

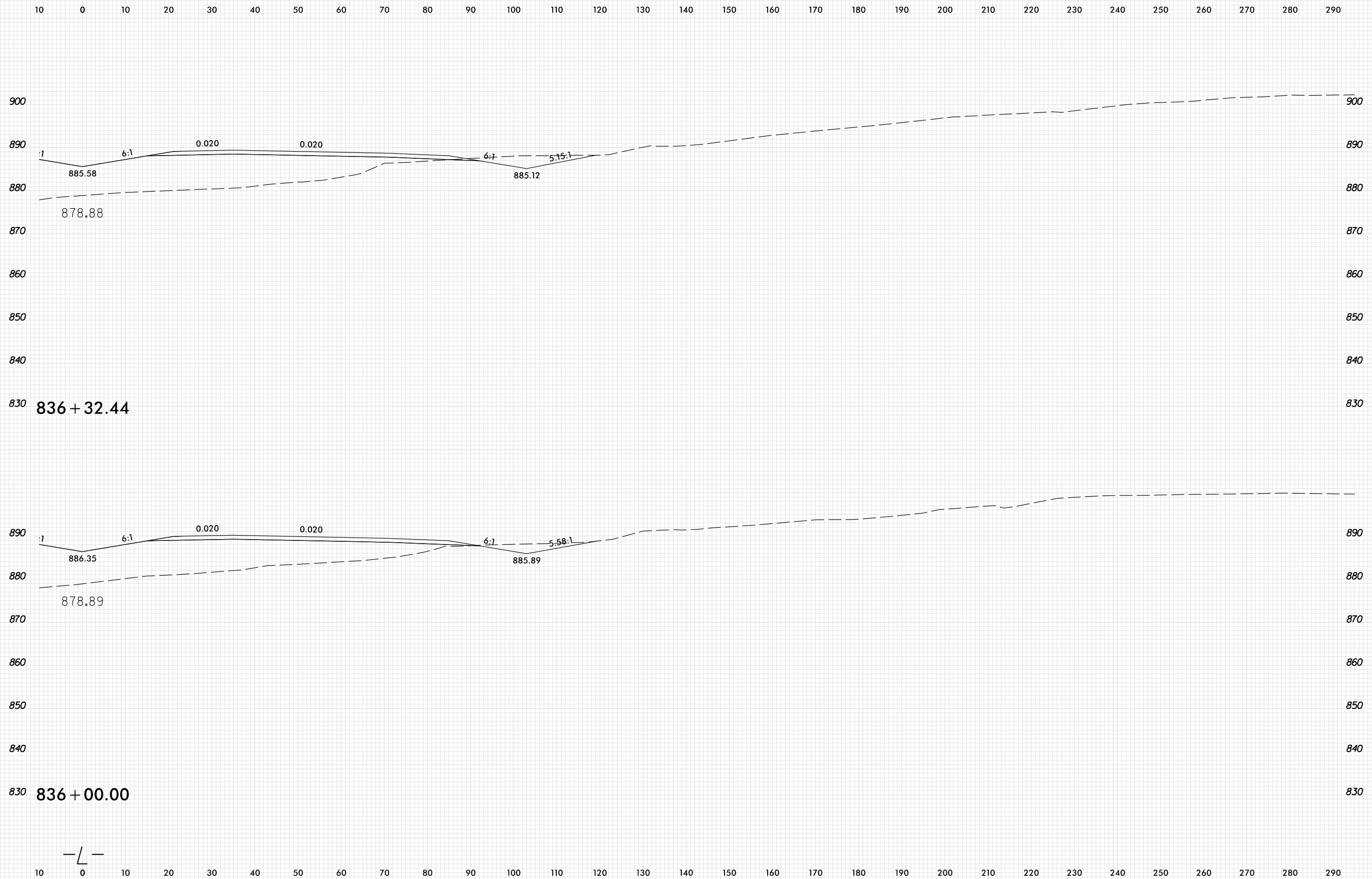

836 + 32.44

836 + 00.00

PLOT DRIVER: NCDOT_pdf_color_eng_100.plt
 USER: SPEREIRA
 DATE: 6/10/2021
 TIME: 2:18:32 PM
 FILE: \



8/23/99

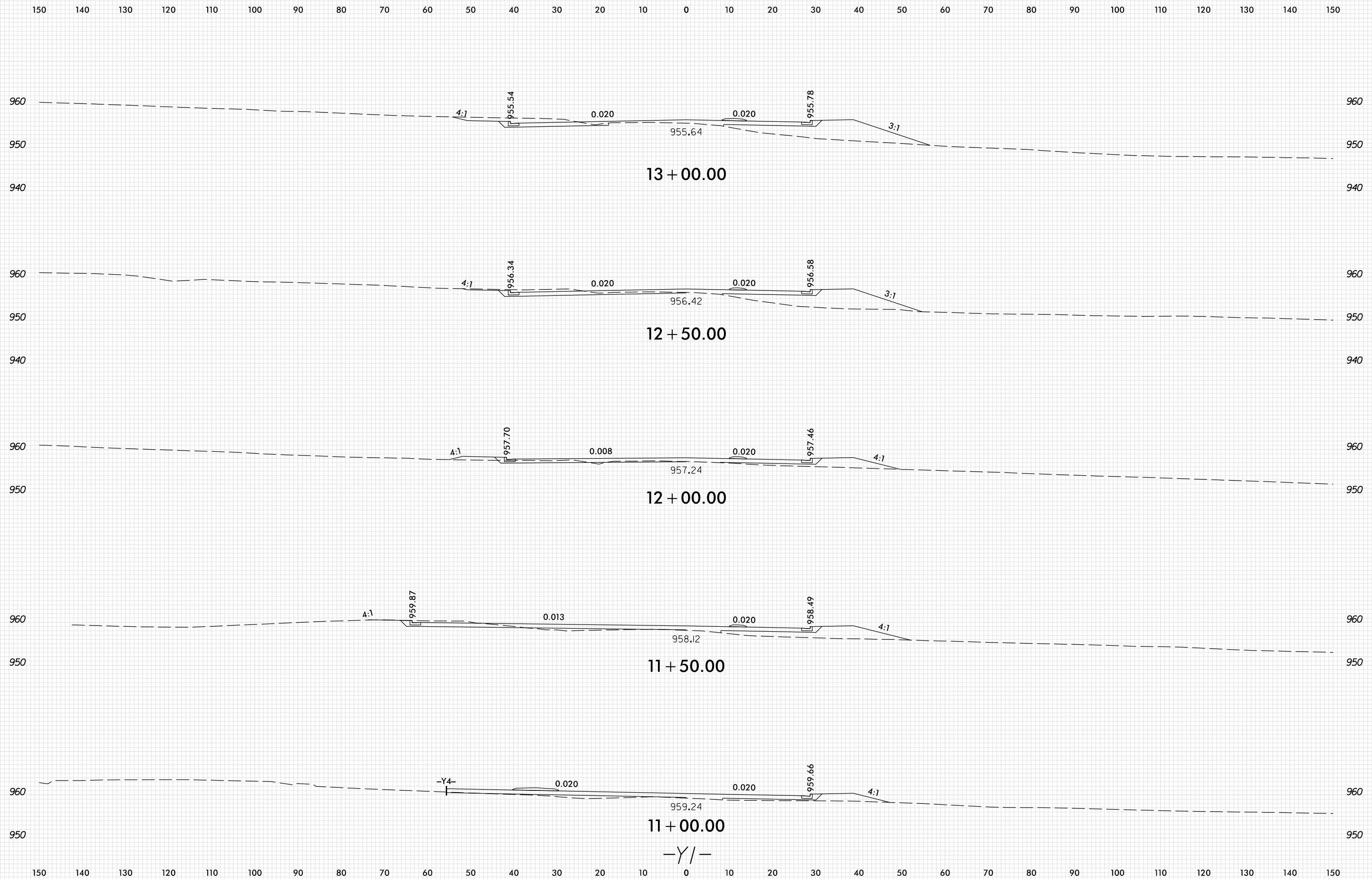

PLOT DRIVER: NCD01_pdf_color_eng_100.plt
 USER: SPEREIRA
 DATE: 6/10/2021
 TIME: 2:18:41 PM
 FILE: \

8/23/99



PROJ. REFERENCE NO.	SHEET NO.
U-2579AB	X-174

150 140 130 120 110 100 90 80 70 60 50 40 30 20 10 0 10 20 30 40 50 60 70 80 90 100 110 120 130 140 150

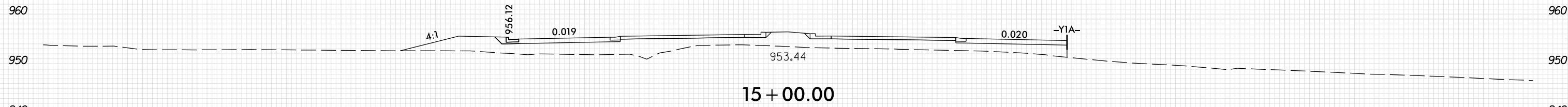

15 + 00.00

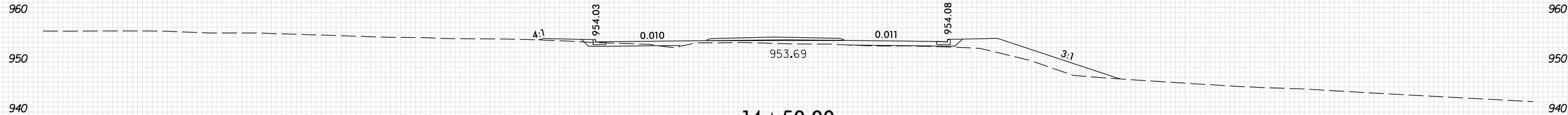

14 + 50.00

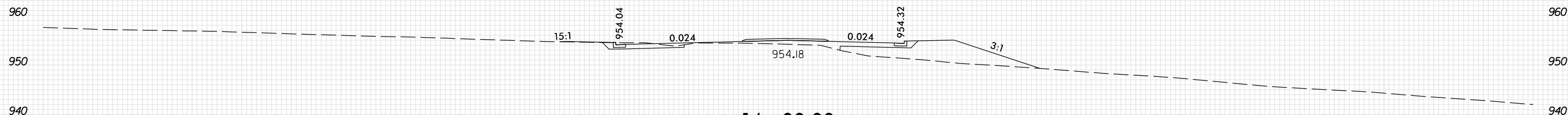

14 + 00.00

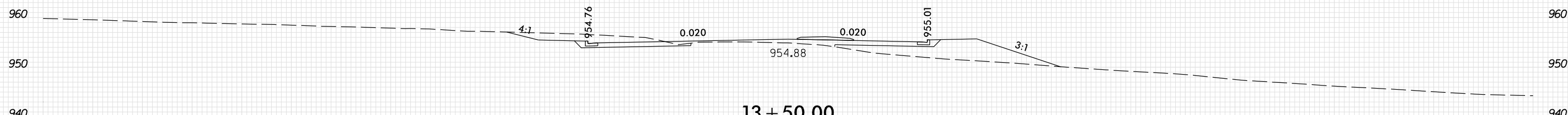

13 + 50.00

-Y/-

150 140 130 120 110 100 90 80 70 60 50 40 30 20 10 0 10 20 30 40 50 60 70 80 90 100 110 120 130 140 150

PLOT DRIVER: NCD01_pdf_color_eng_100.plt
 USER: SPEREIRA
 DATE: 6/10/2021
 TIME: 2:18:42 PM
 FILE: \

8/23/99

0 5 10	PROJ. REFERENCE NO.	SHEET NO.
	U-2579AB	X-174A

150 140 130 120 110 100 90 80 70 60 50 40 30 20 10 0 10 20 30 40 50 60 70 80 90 100 110 120 130 140 150

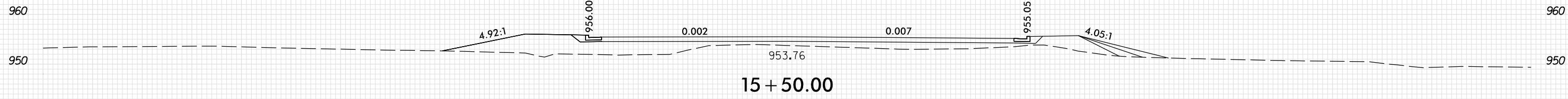
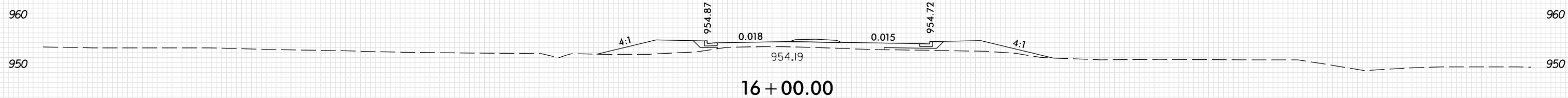
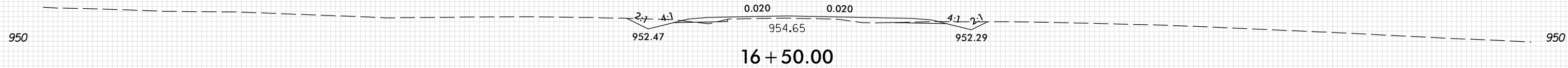
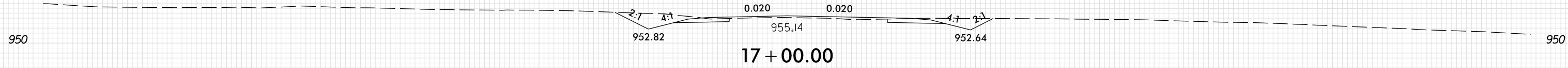
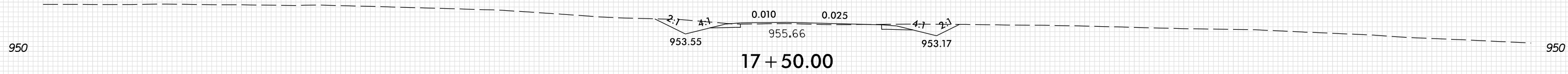

150 140 130 120 110 100 90 80 70 60 50 40 30 20 10 0 10 20 30 40 50 60 70 80 90 100 110 120 130 140 150

PLOT DRIVER: NCD01_pdf_color_eng_100.plt
USER: SPEREIRA
DATE: 6/10/2021
TIME: 2:18:42 PM
FILE: \

-Y/-

8/23/99

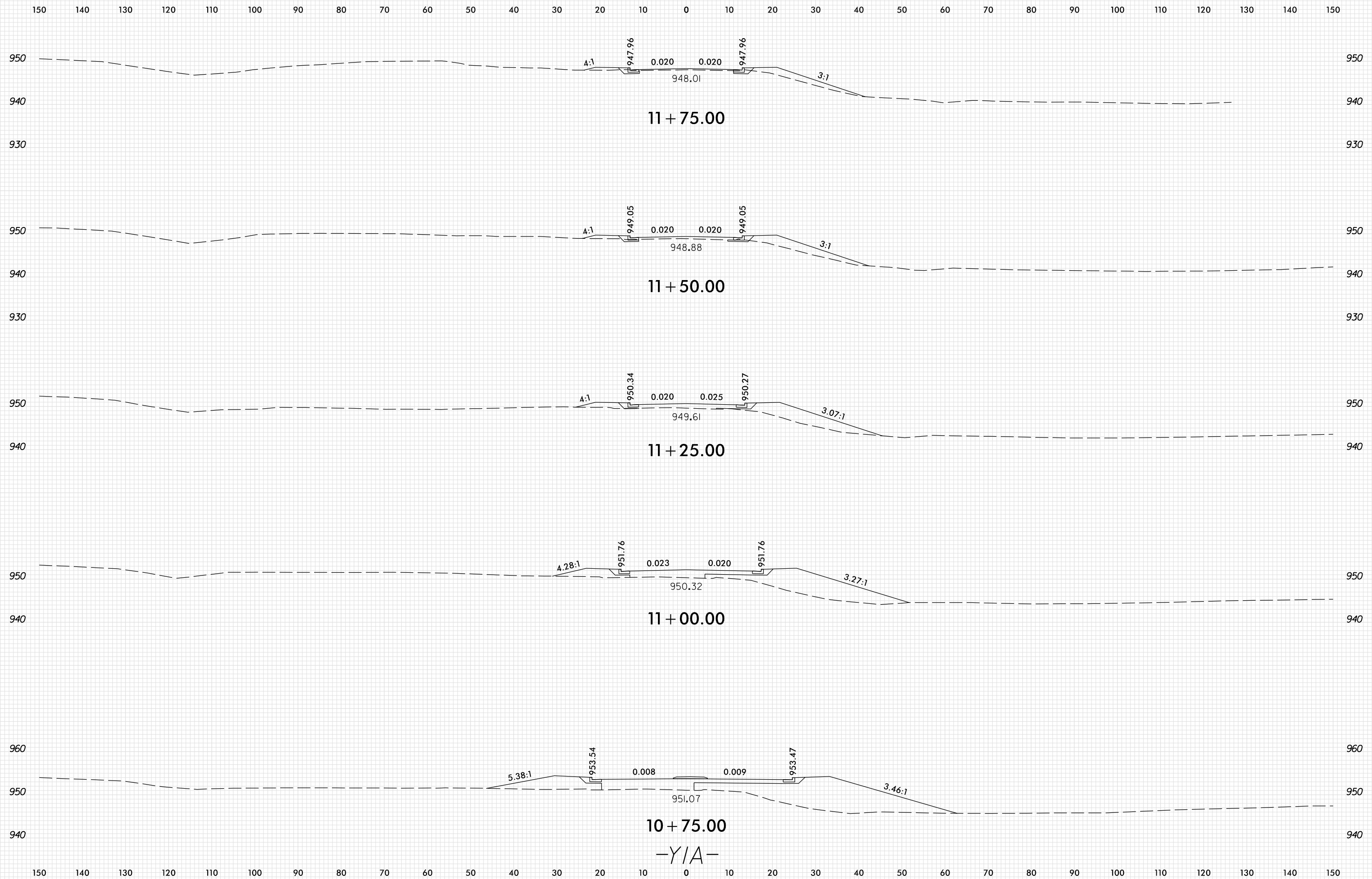

PLOT DRIVER: NCD01_pdf_color_eng_100.plt
 USER: SPEREIRA
 DATE: 6/10/2021
 TIME: 2:18:49 PM
 FILE: \

-Y/A-

8/23/99

0 5 10	PROJ. REFERENCE NO.	SHEET NO.
	U-2579AB	X-174C

150 140 130 120 110 100 90 80 70 60 50 40 30 20 10 0 10 20 30 40 50 60 70 80 90 100 110 120 130 140 150

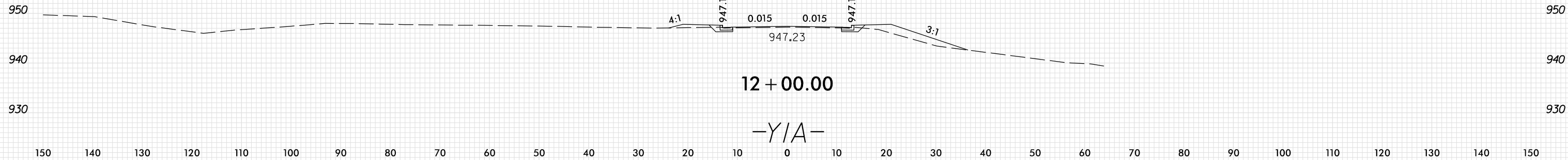

PLOT DRIVER: NCD01_pdf_color_eng_100.plt
 USER: SPEREIRA
 FILE: \

DATE: 6/10/2021
 TIME: 2:18:50 PM

PENTABLE: xpl_en_v8.tbl

8/23/99



PROJ. REFERENCE NO.	SHEET NO.
U-2579AB	X-175

150 140 130 120 110 100 90 80 70 60 50 40 30 20 10 0 10 20 30 40 50 60 70 80 90 100 110 120 130 140 150

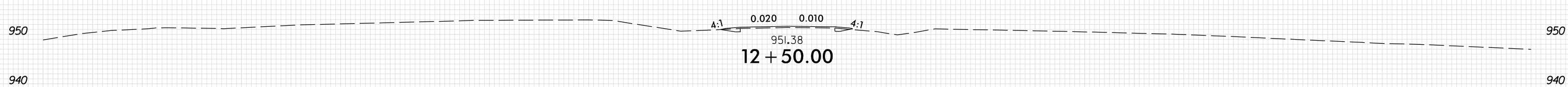
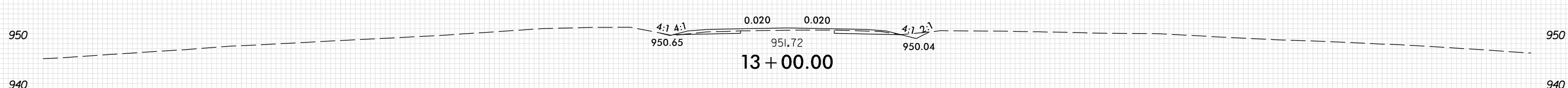
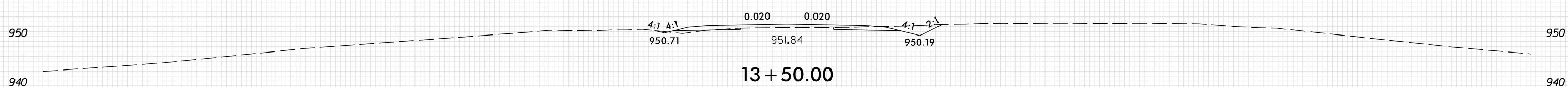
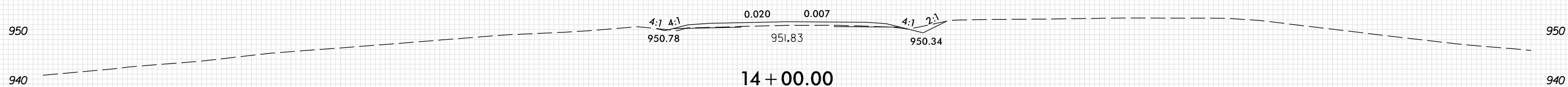
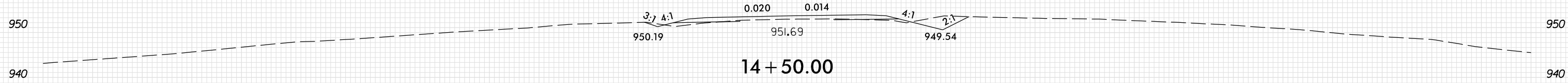

-YIB-

150 140 130 120 110 100 90 80 70 60 50 40 30 20 10 0 10 20 30 40 50 60 70 80 90 100 110 120 130 140 150

PLOT DRIVER: NCD01_pdf_color_eng_100.plt
 USER: SPEREIRA
 FILE: \PENTABLE: xpl_en_v8.tbl
 DATE: 6/10/2021
 TIME: 2:19:05 PM

8/23/99



PROJ. REFERENCE NO.	SHEET NO.
U-2579AB	X-176

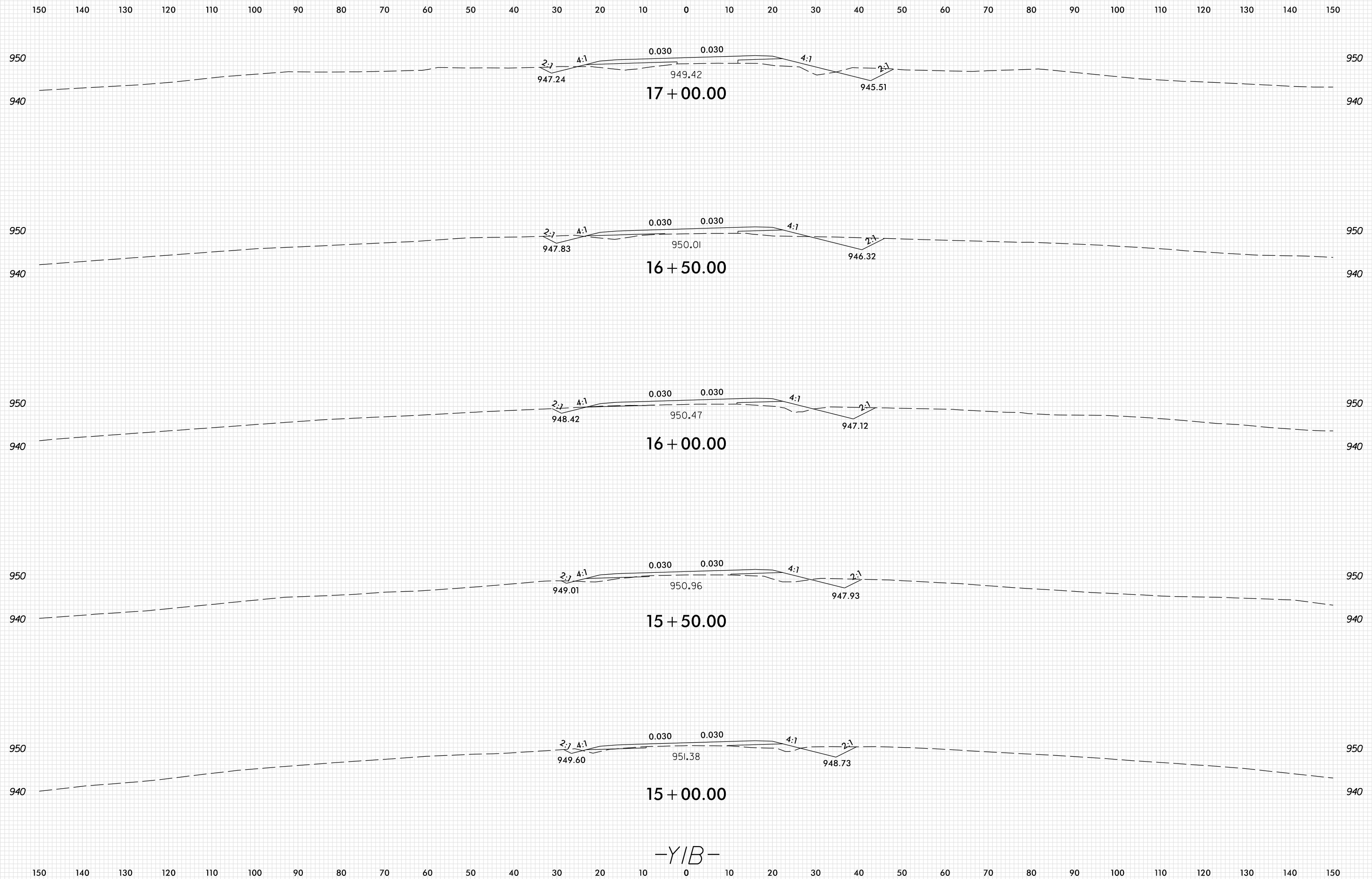

-YIB-

PLOT DRIVER: NCD01_pdf_color_eng_100.plt
 USER: SPEREIRA
 DATE: 6/10/2021
 TIME: 2:19:06 PM
 FILE: \

8/23/99

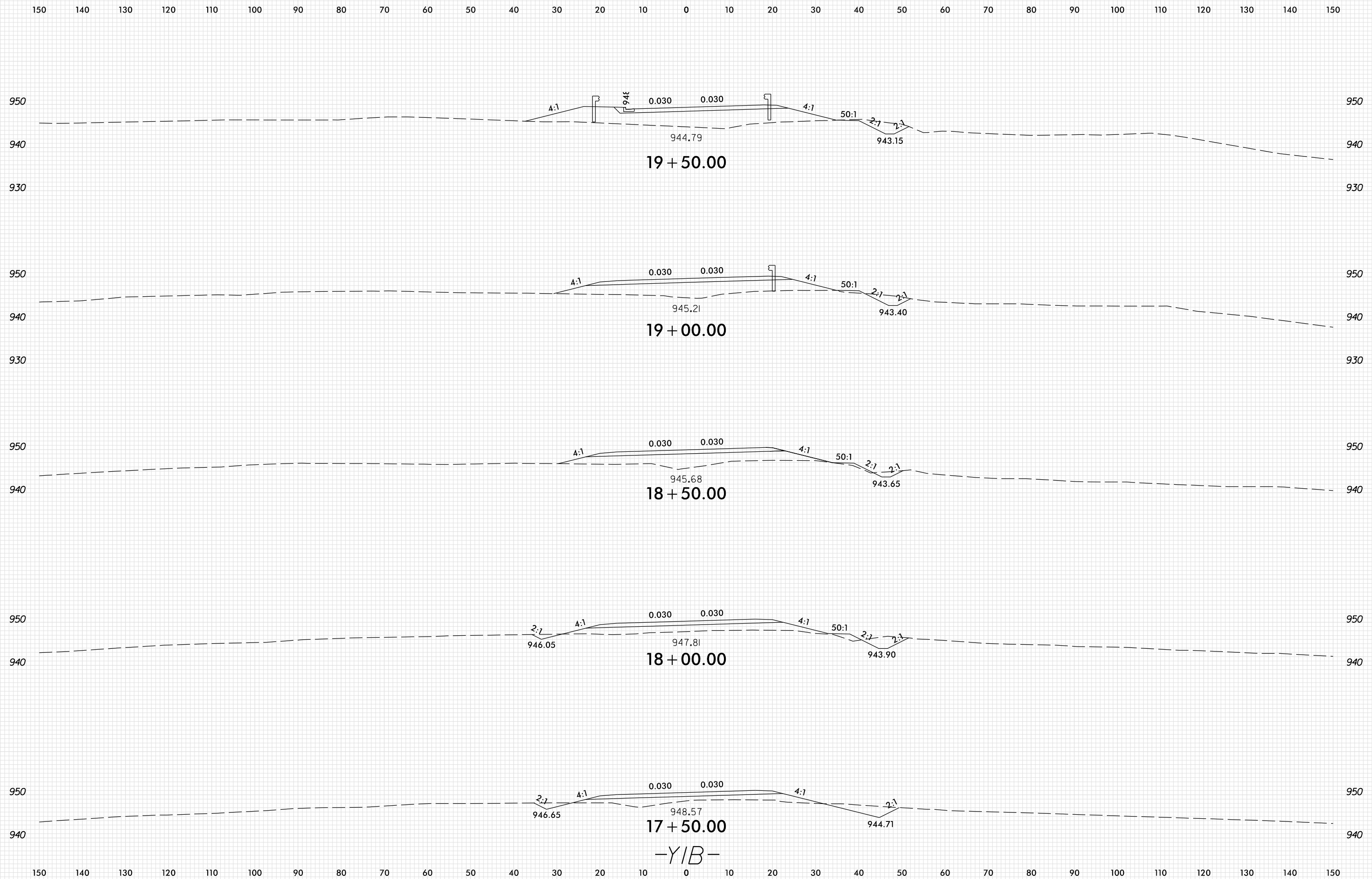

PLOT DRIVER: NCDOT_pdf_color_eng_100.plt
 USER: SPEREIRA
 DATE: 6/10/2021
 TIME: 2:19:06 PM
 FILE: \

8/23/99

150 140 130 120 110 100 90 80 70 60 50 40 30 20 10 0 10 20 30 40 50 60 70 80 90 100 110 120 130 140 150

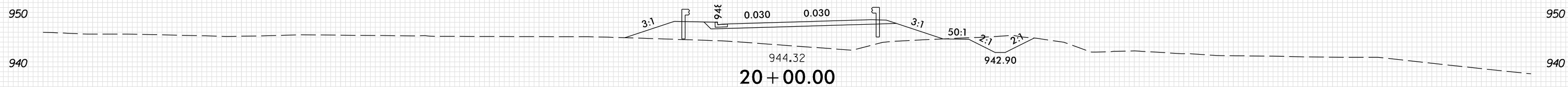
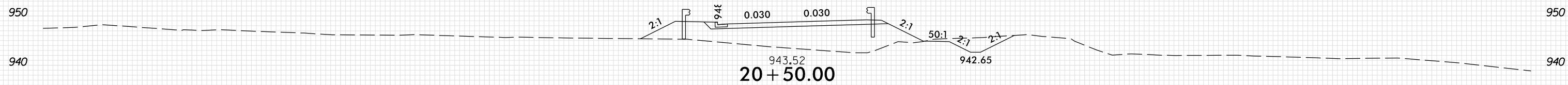
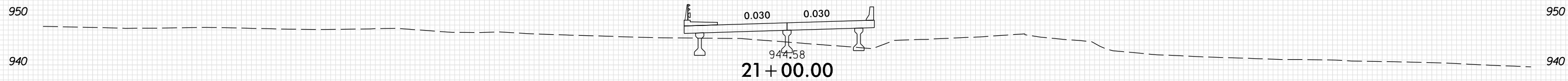
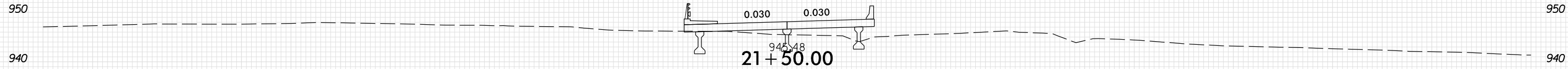
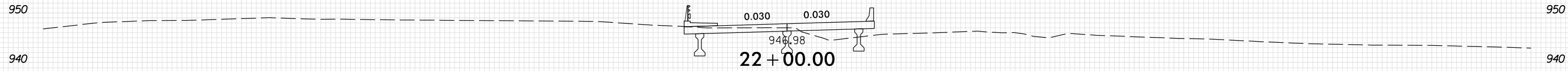

-YIB-

150 140 130 120 110 100 90 80 70 60 50 40 30 20 10 0 10 20 30 40 50 60 70 80 90 100 110 120 130 140 150

PLOT DRIVER: NCD01_.pdf_color_eng_100.plt
USER: SPEREIRA
DATE: 6/10/2021
TIME: 2:19:07 PM
FILE: \

8/23/99



PROJ. REFERENCE NO.	SHEET NO.
U-2579AB	X-179

150 140 130 120 110 100 90 80 70 60 50 40 30 20 10 0 10 20 30 40 50 60 70 80 90 100 110 120 130 140 150

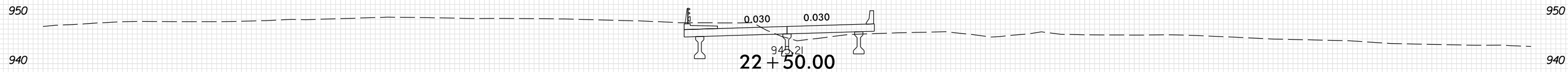
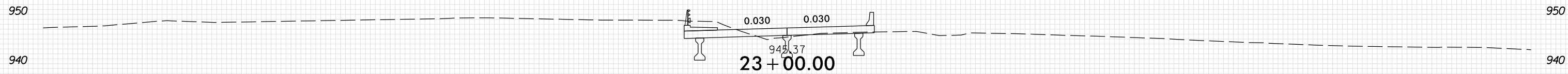
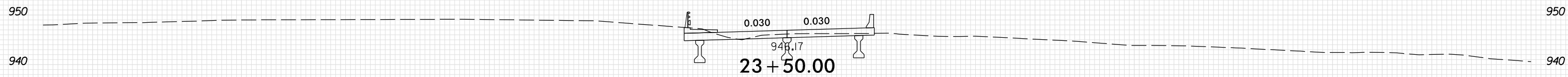
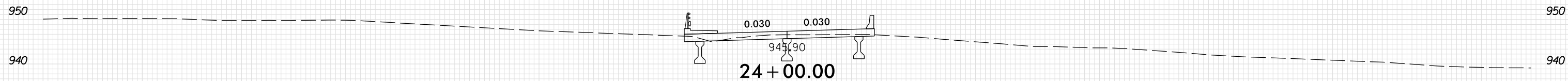
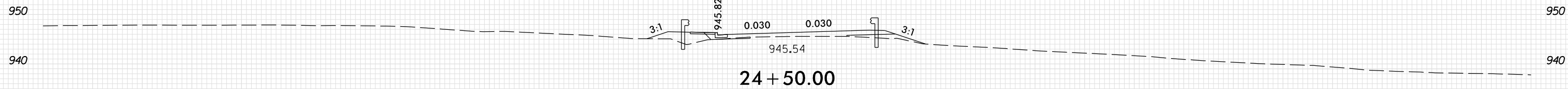

-YIB-

150 140 130 120 110 100 90 80 70 60 50 40 30 20 10 0 10 20 30 40 50 60 70 80 90 100 110 120 130 140 150

PLOT DRIVER: NCD01_pdf_color_eng_100.plt
USER: SPEREIRA
DATE: 6/10/2021
TIME: 2:19:07 PM
FILE: \

8/23/99



PROJ. REFERENCE NO.	SHEET NO.
U-2579AB	X-180

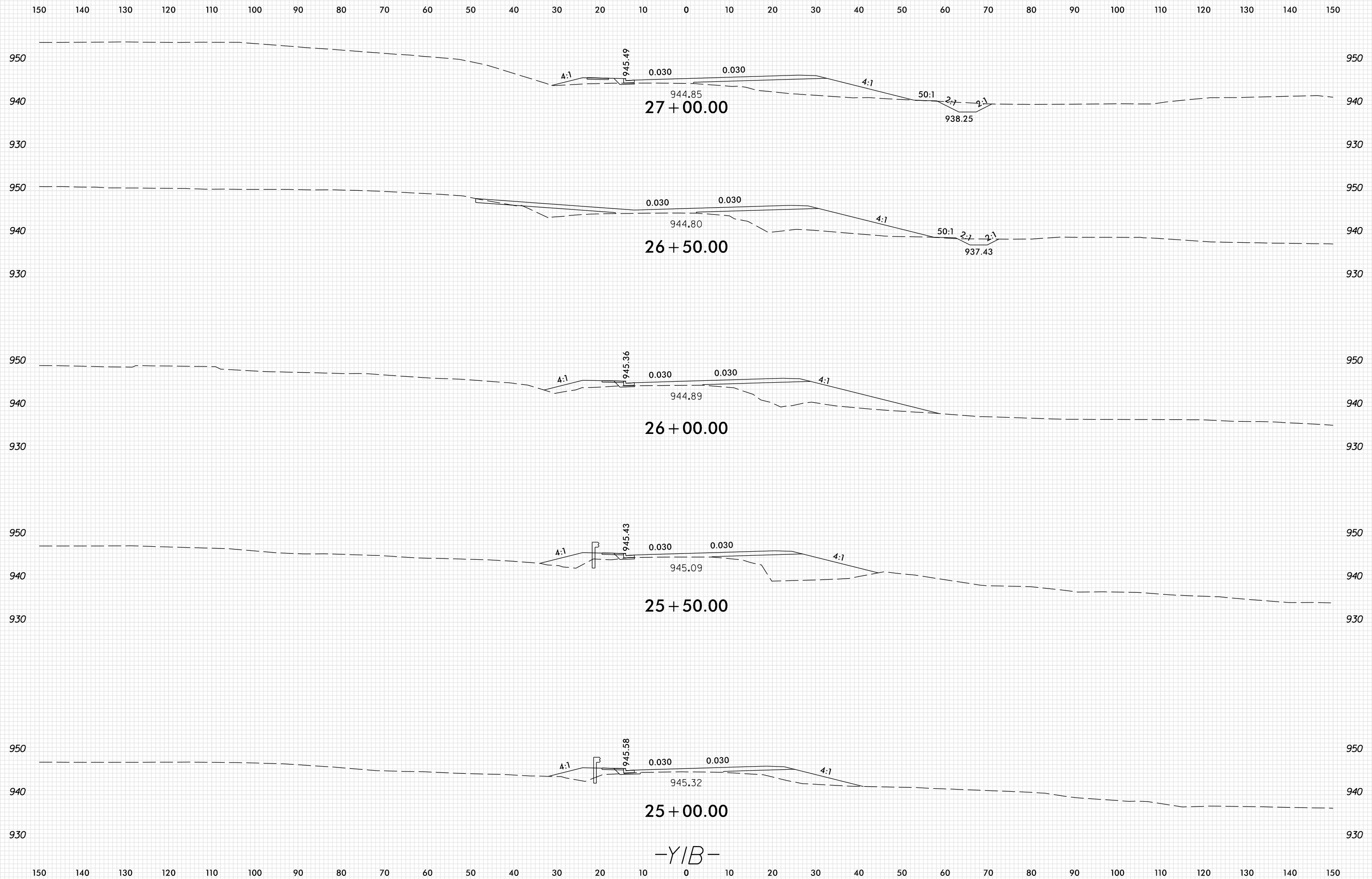

-YIB-

PLOT DRIVER: NCDOT_pdf_color_eng_100.plt
 USER: SPEREIRA
 DATE: 6/10/2021
 TIME: 2:19:08 PM
 FILE: \

8/23/99

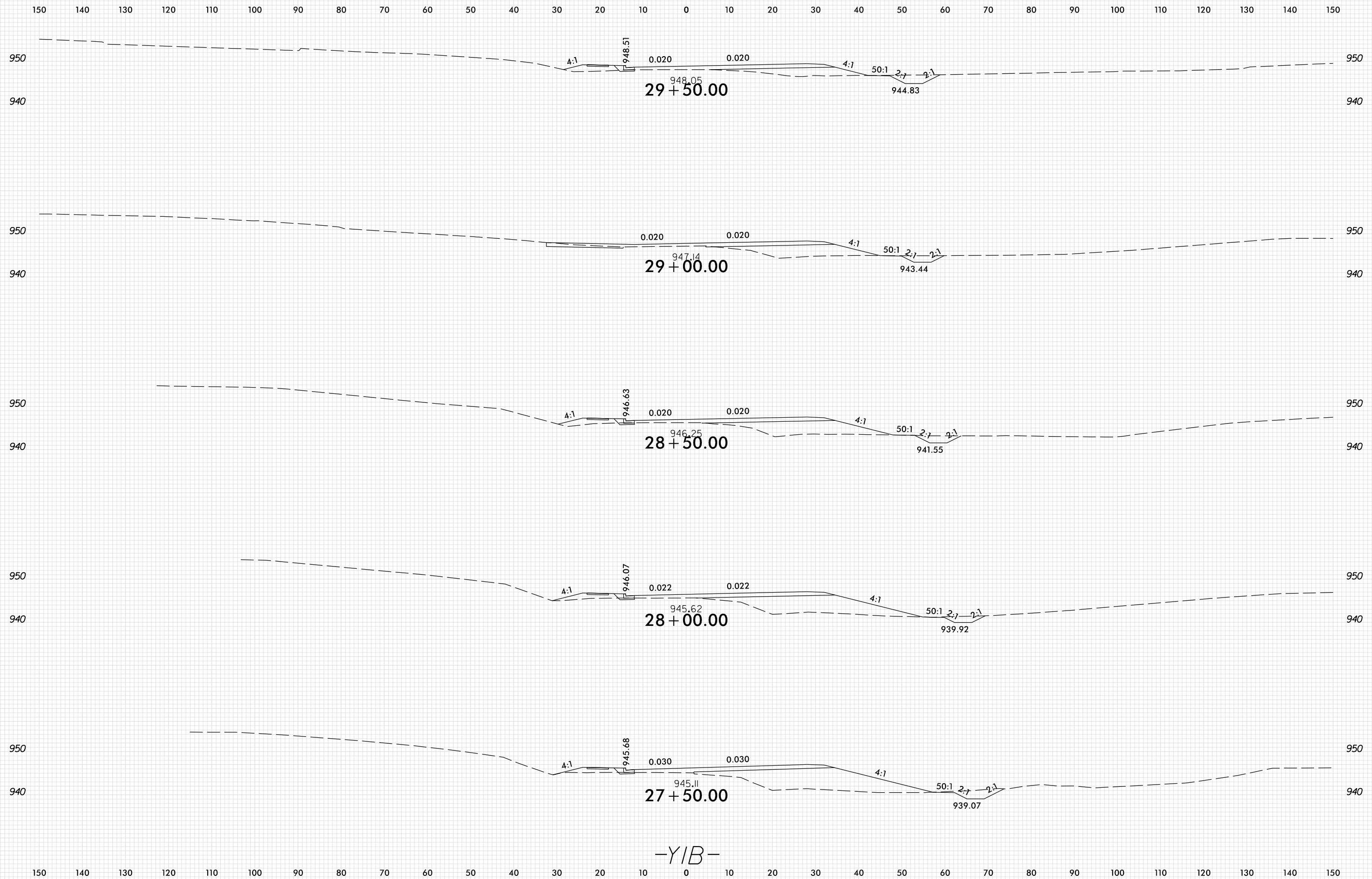

-YIB-

8/23/99

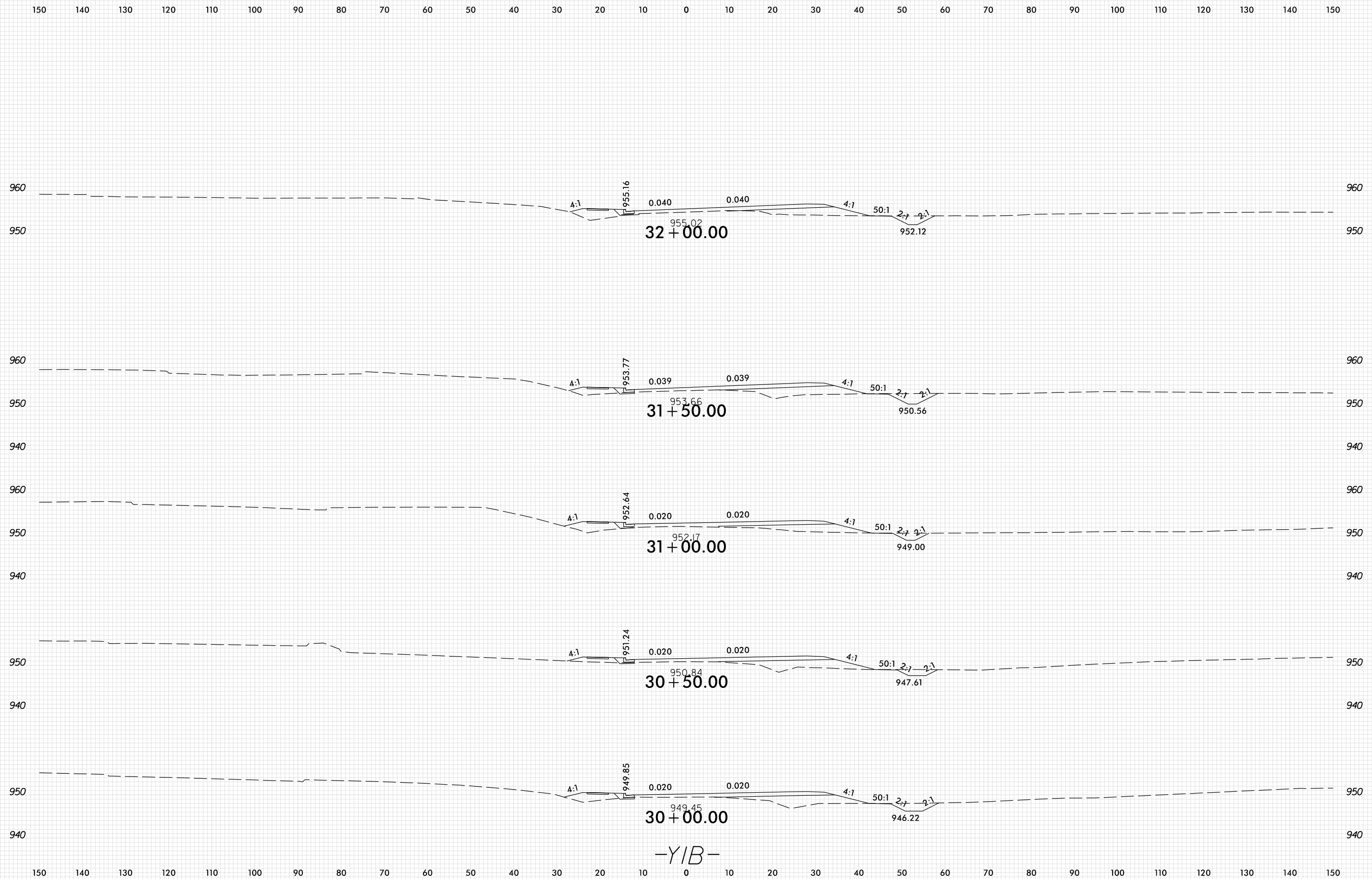

-YIB-

PLOT DRIVER: NCD01_pdf_color_eng_100.plt
 USER: SPEREIRA
 DATE: 6/10/2021
 TIME: 2:19:09 PM
 FILE: \

8/23/99

0 5 10	PROJ. REFERENCE NO.	SHEET NO.
	U-2579AB	X-183

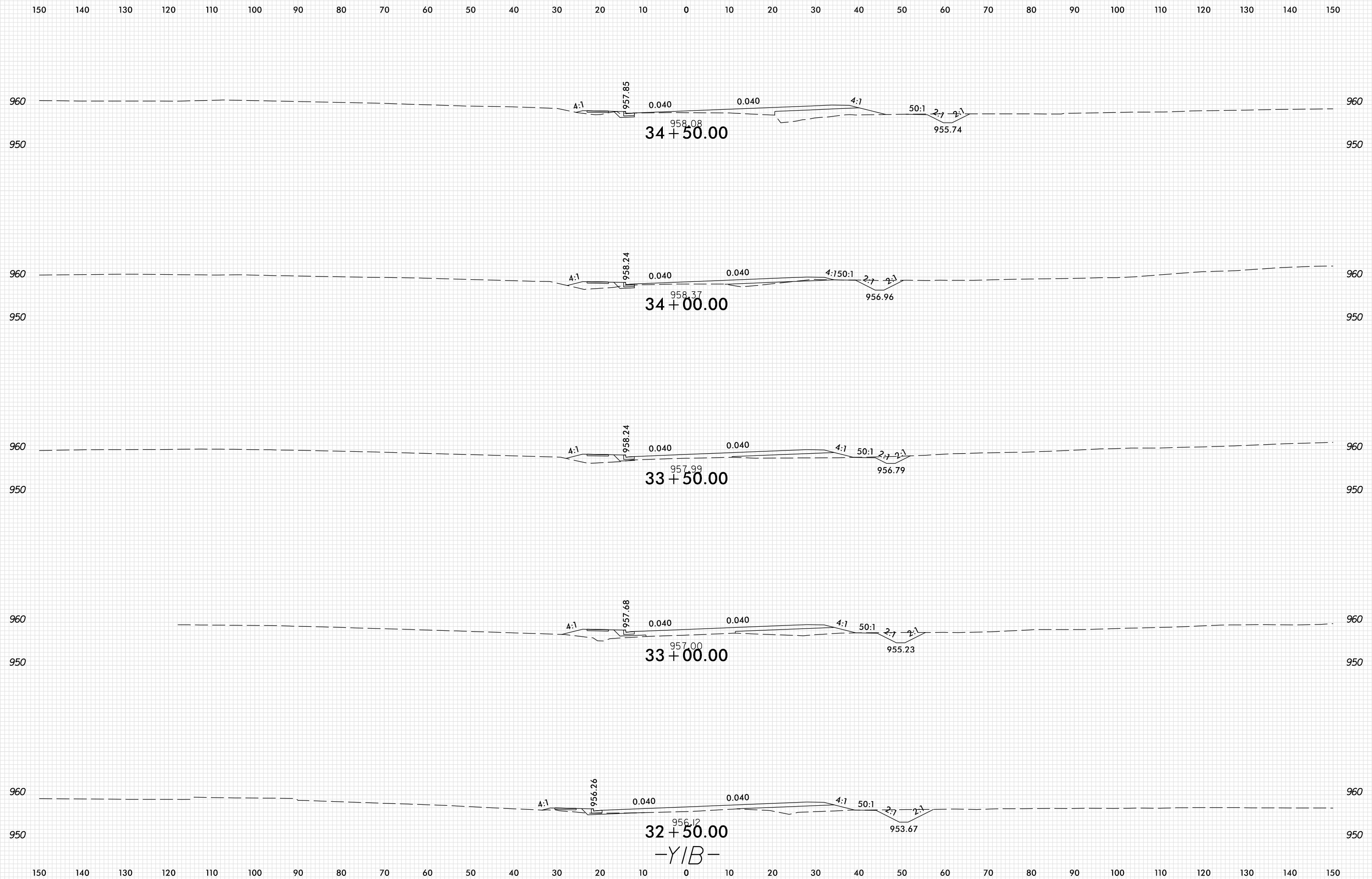

PLOT DRIVER: NCD01_.pdf_color_eng_100.plt
 USER: SPEREIRA
 DATE: 6/10/2021
 TIME: 2:19:10 PM
 FILE: \

8/23/99

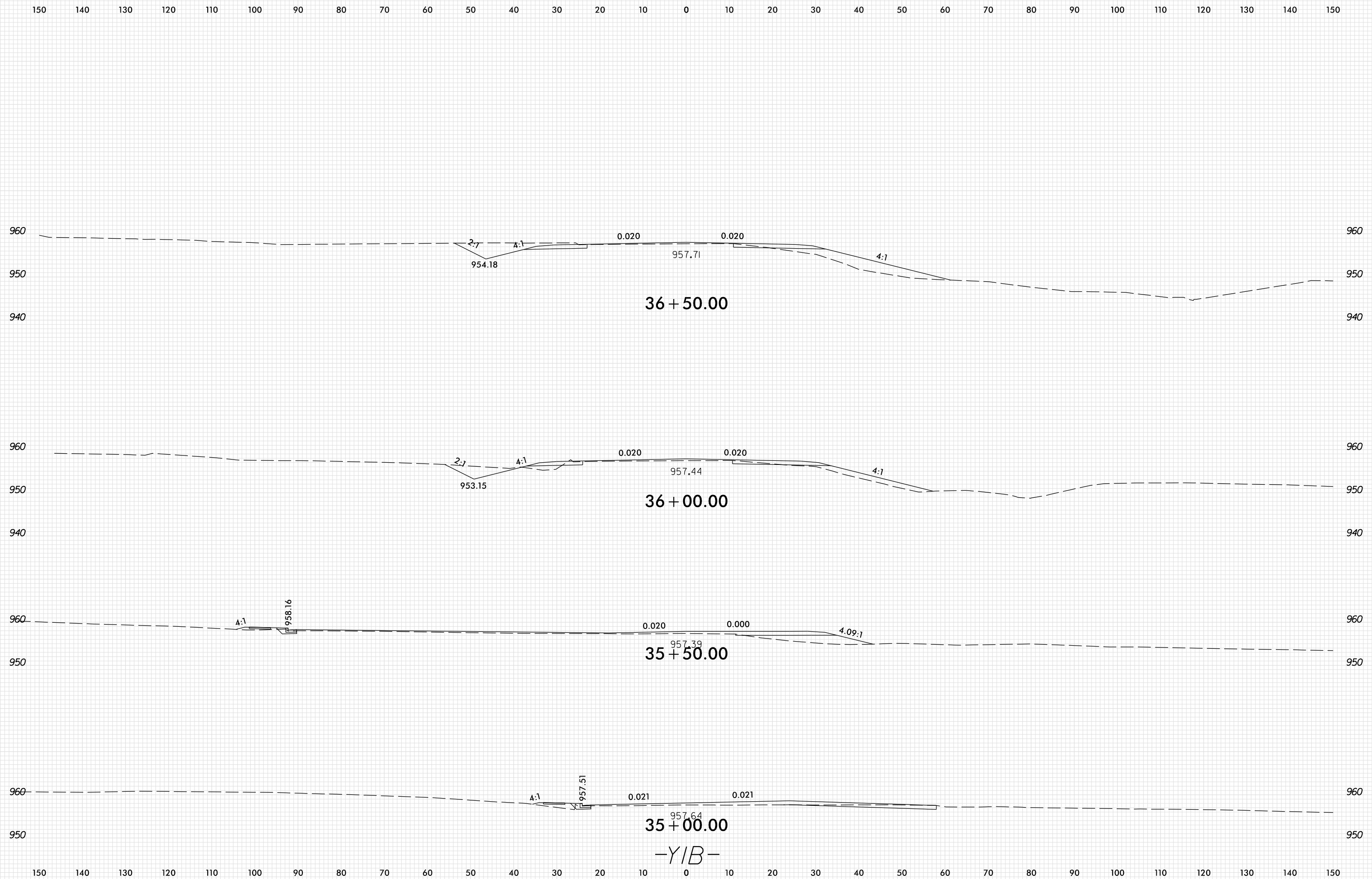

-YIB-

PLOT DRIVER: NCD01_pdf_color_eng_100.plt
 USER: SPEREIRA
 DATE: 6/10/2021
 TIME: 2:19:11 PM
 FILE: \

8/23/99

0 5 10	PROJ. REFERENCE NO.	SHEET NO.
	U-2579AB	X-185

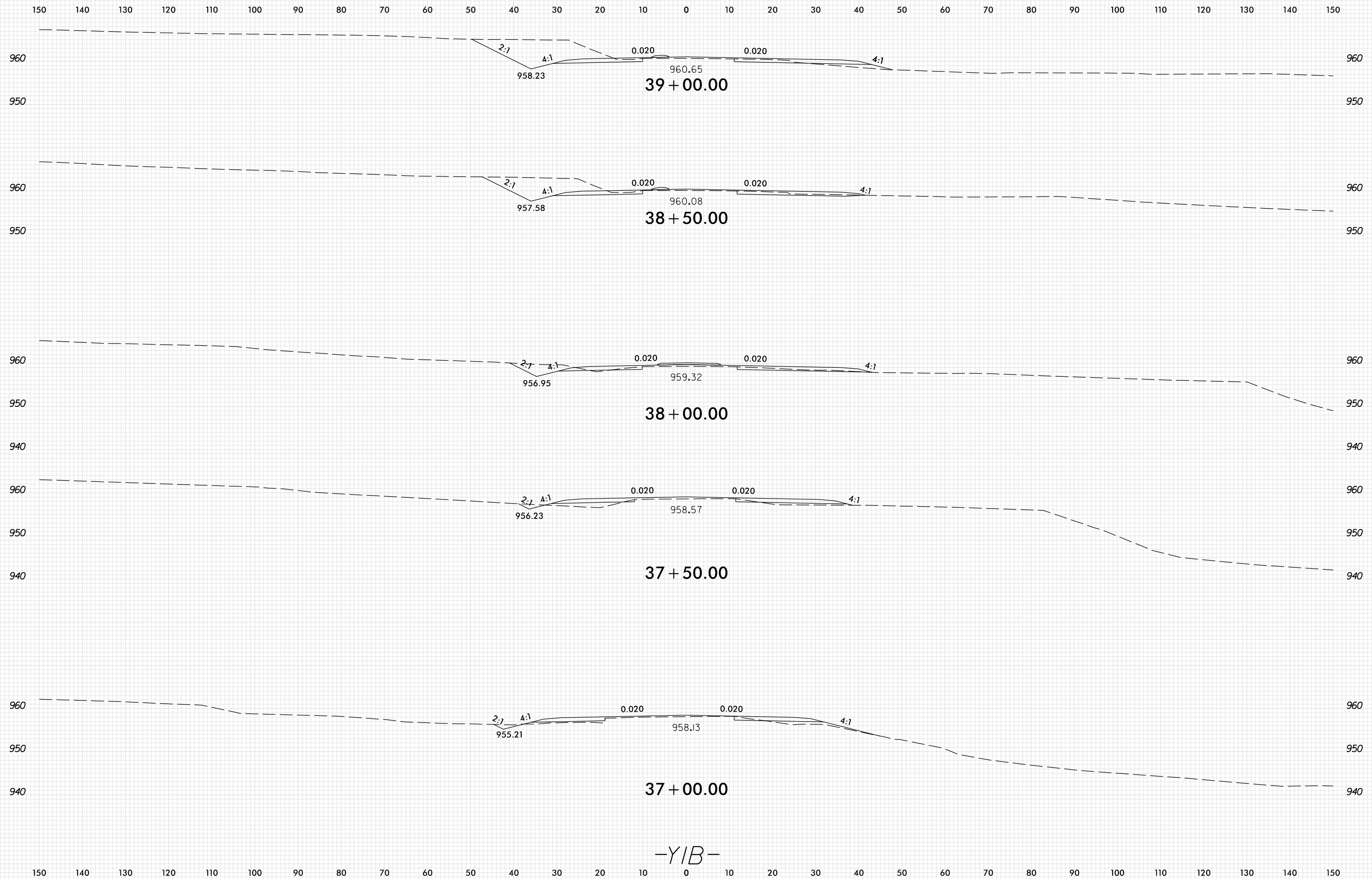

-YIB-

PLOT DRIVER: NCDOT_pdf_color_eng_100.plt
 USER: SPEREIRA
 DATE: 6/10/2021
 TIME: 2:19:11 PM
 FILE: \

8/23/99

0 5 10	PROJ. REFERENCE NO.	SHEET NO.
	U-2579AB	X-186

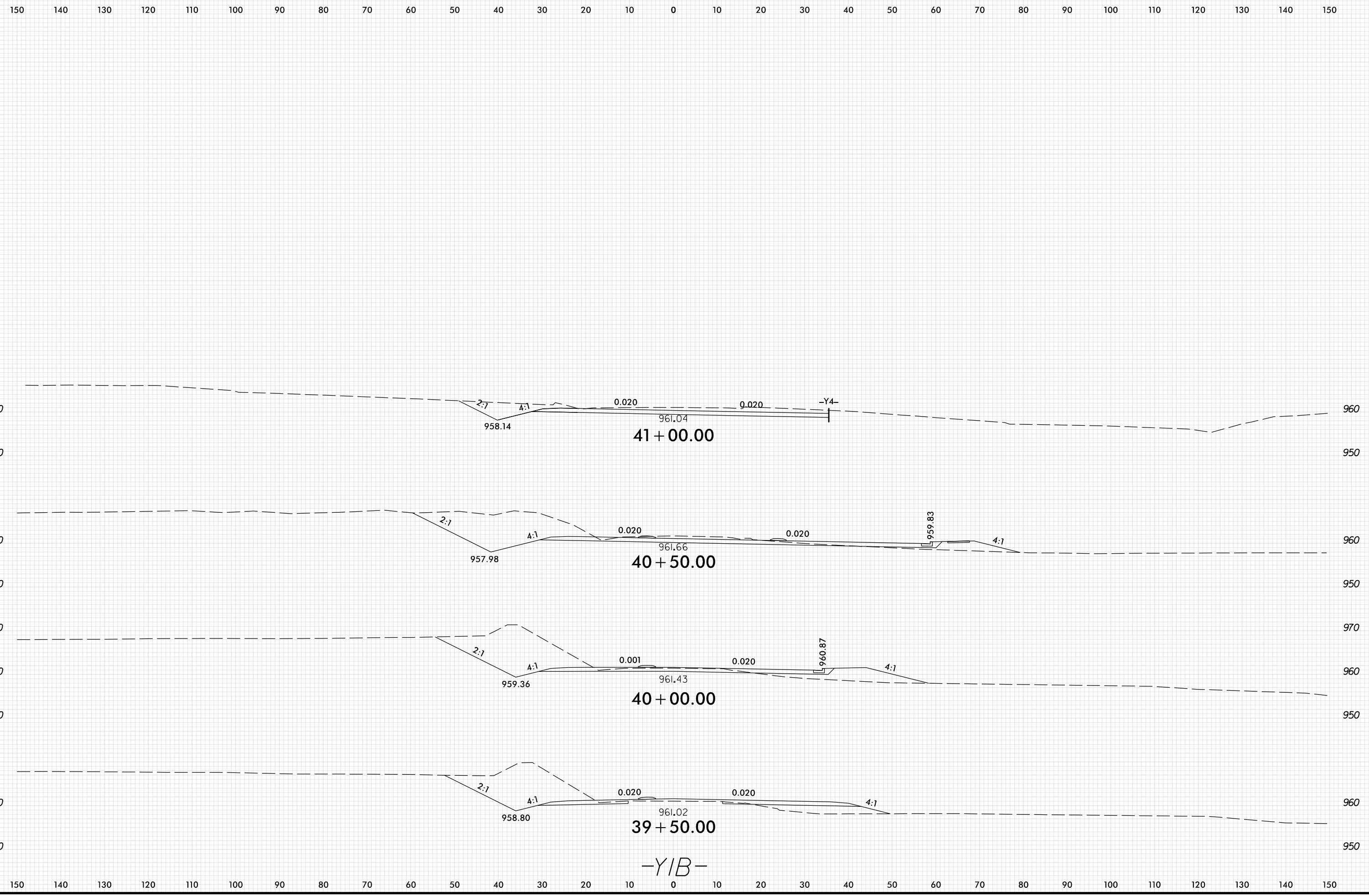

PLOT DRIVER: NCD01_pdf_color_eng_100.plt
 USER: SPEREIRA
 DATE: 6/10/2021
 TIME: 2:19:12 PM
 FILE: \

8/23/99

0 5 10	PROJ. REFERENCE NO.	SHEET NO.
	U-2579AB	X-187

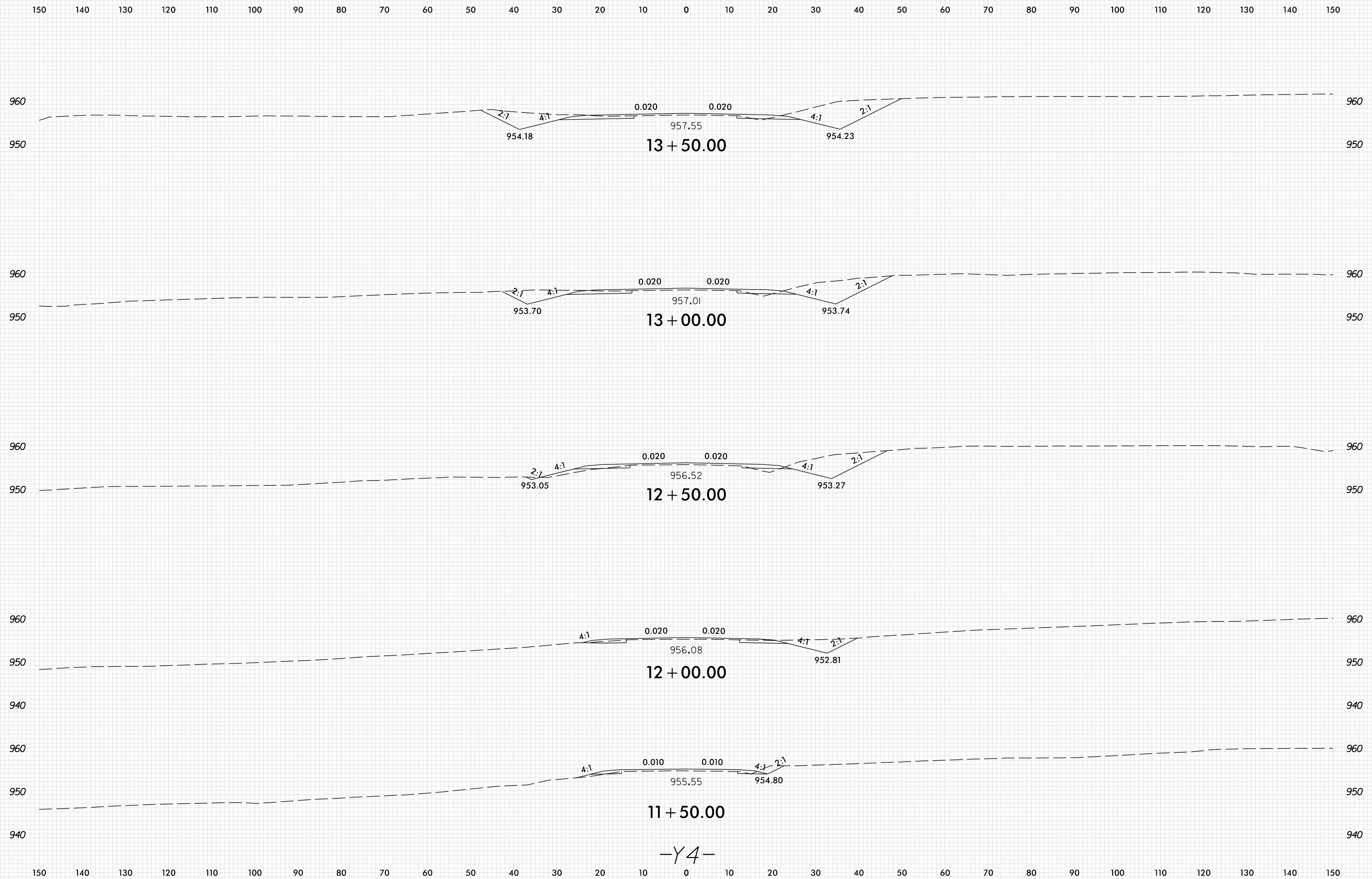

-Y4-

PLOT DRIVER: NCDOT_pdf_color_eng_100.plt
 USER: SPEREIRA
 DATE: 6/10/2021
 TIME: 2:19:20 PM
 FILE: \

8/23/99

0 5 10	PROJ. REFERENCE NO.	SHEET NO.
	U-2579AB	X-188

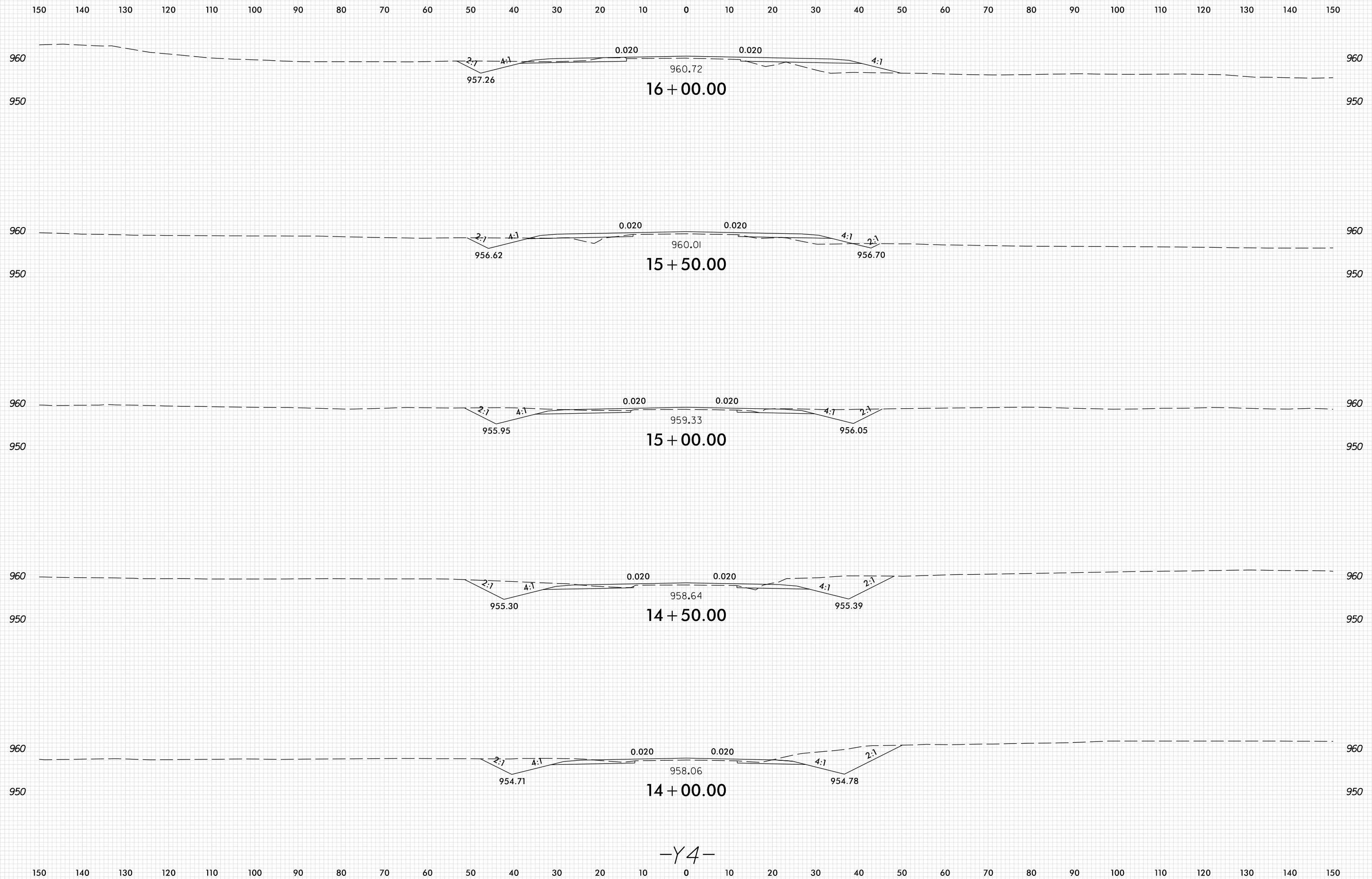

-Y4-

PLOT DRIVER: NCD01_pdf_color_eng_100.plt
 USER: SPEREIRA
 DATE: 6/10/2021
 TIME: 2:19:21 PM
 FILE: \

8/23/99

0 5 10	PROJ. REFERENCE NO.	SHEET NO.
	U-2579AB	X-189

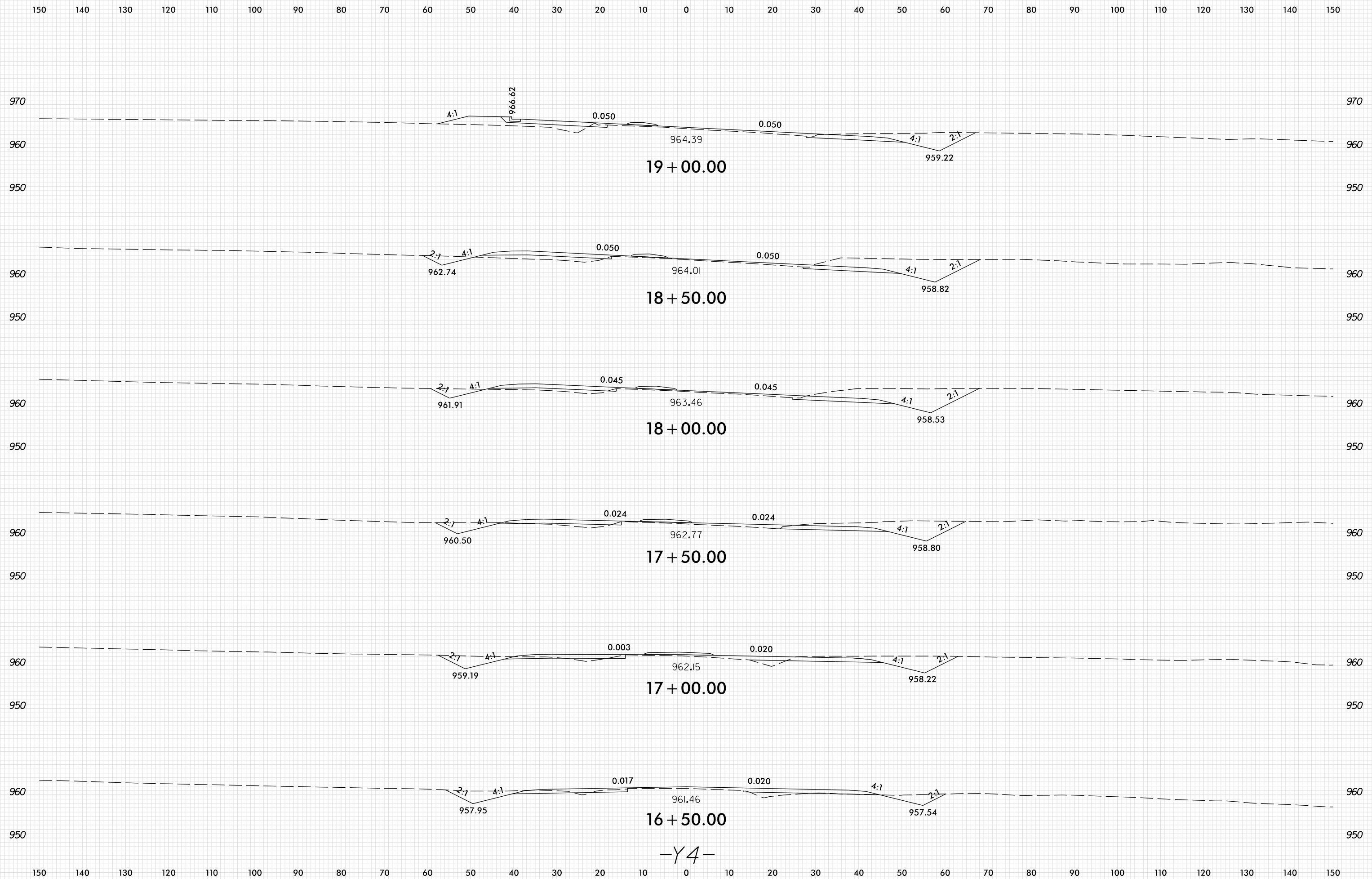

PLOT DRIVER: NCDOT_pdf_color_eng_100.plt
 USER: SPEREIRA
 DATE: 6/10/2021
 TIME: 2:19:22 PM
 FILE: \

-Y4-

8/23/99

0 5 10	PROJ. REFERENCE NO.	SHEET NO.
	U-2579AB	X-190

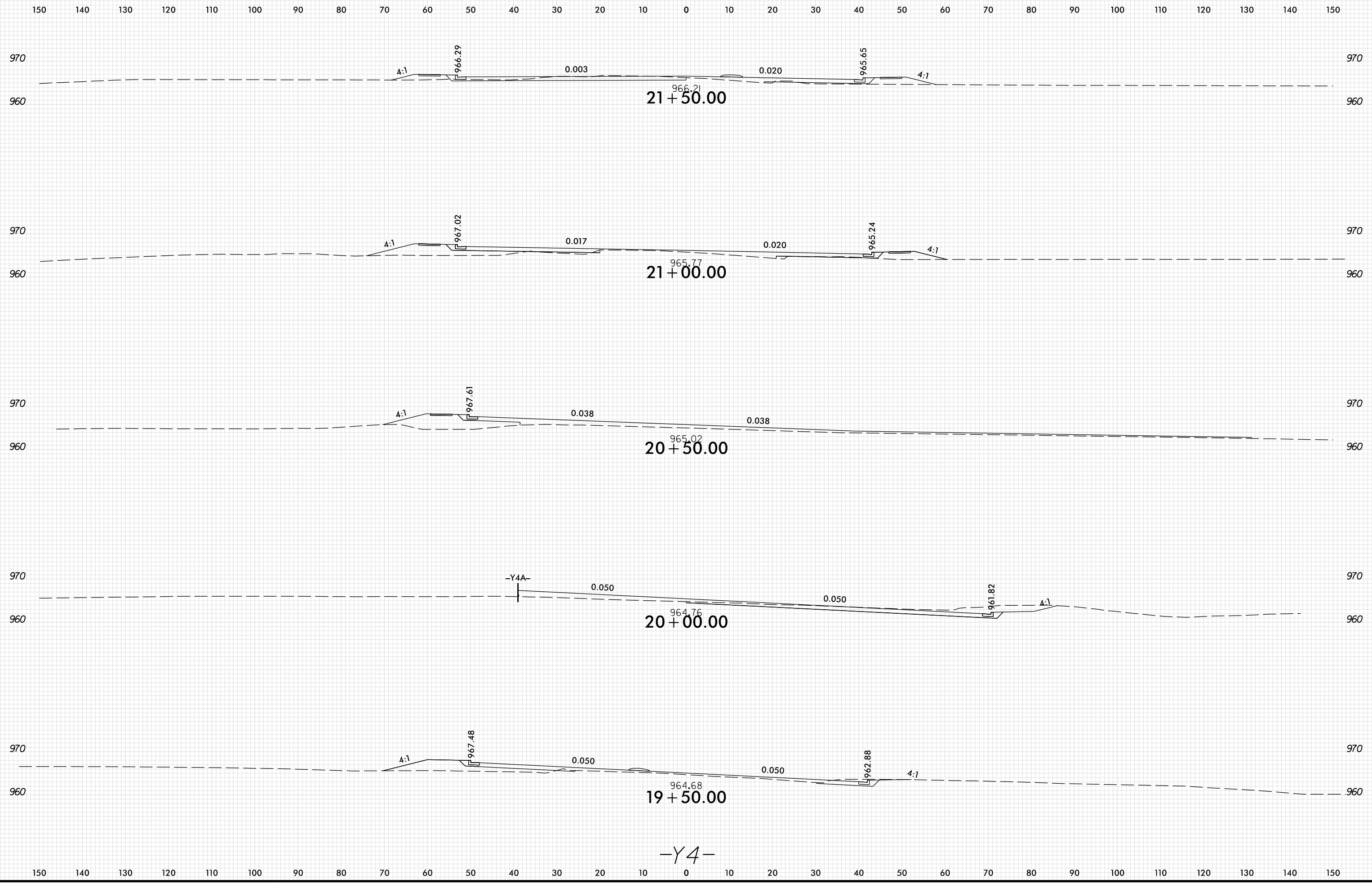

PLOT DRIVER: NCD01_pdf_color_eng_100.plt
 USER: SPEREIRA
 DATE: 6/10/2021
 TIME: 2:19:22 PM
 FILE: \

8/23/99

0 5 10	PROJ. REFERENCE NO.	SHEET NO.
	U-2579AB	X-191

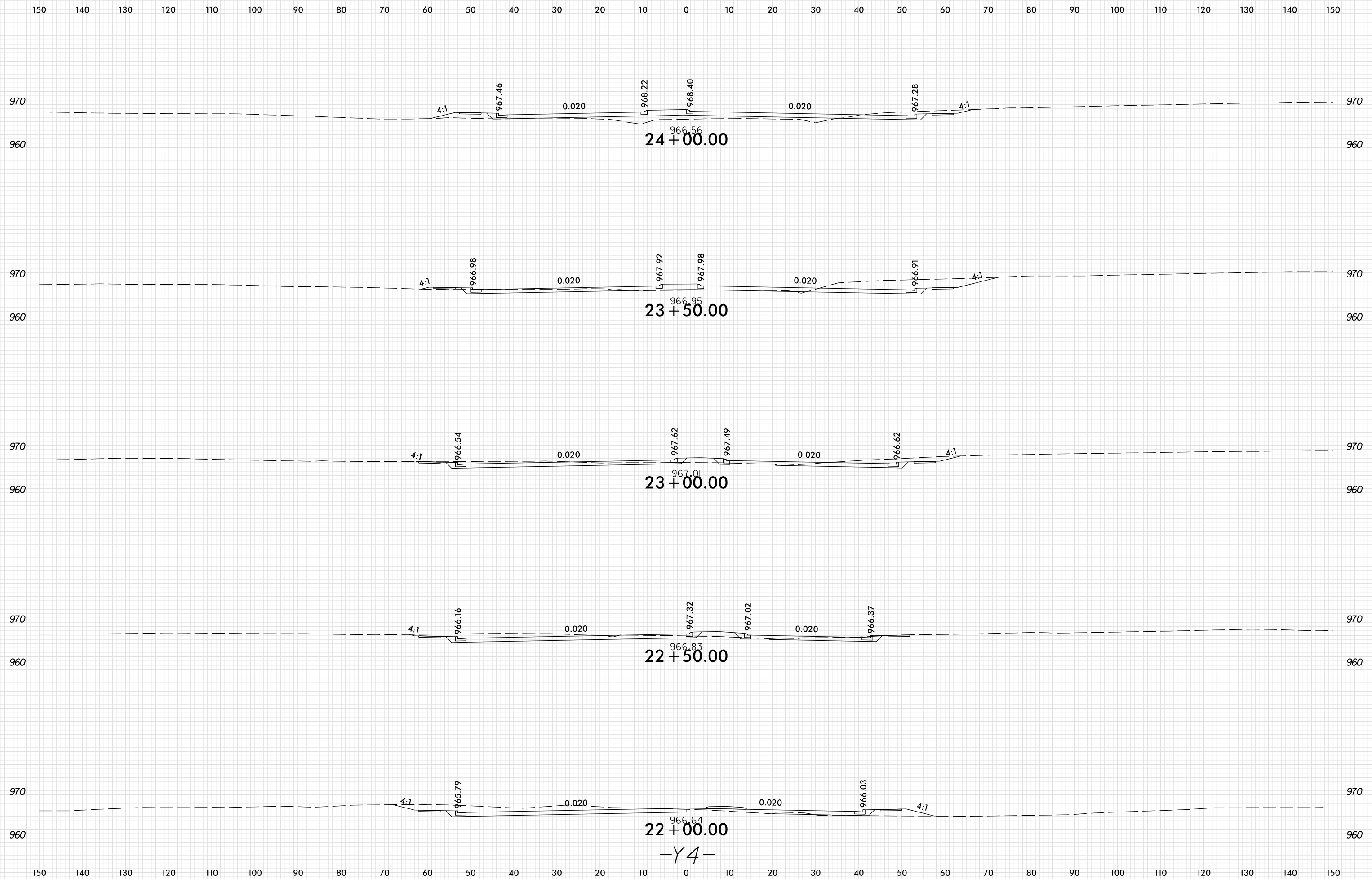

PLOT DRIVER: NCD01_.pdf_color_eng_100.plt
 USER: SPEREIRA
 DATE: 6/10/2021
 TIME: 2:19:23 PM
 FILE: \

8/23/99

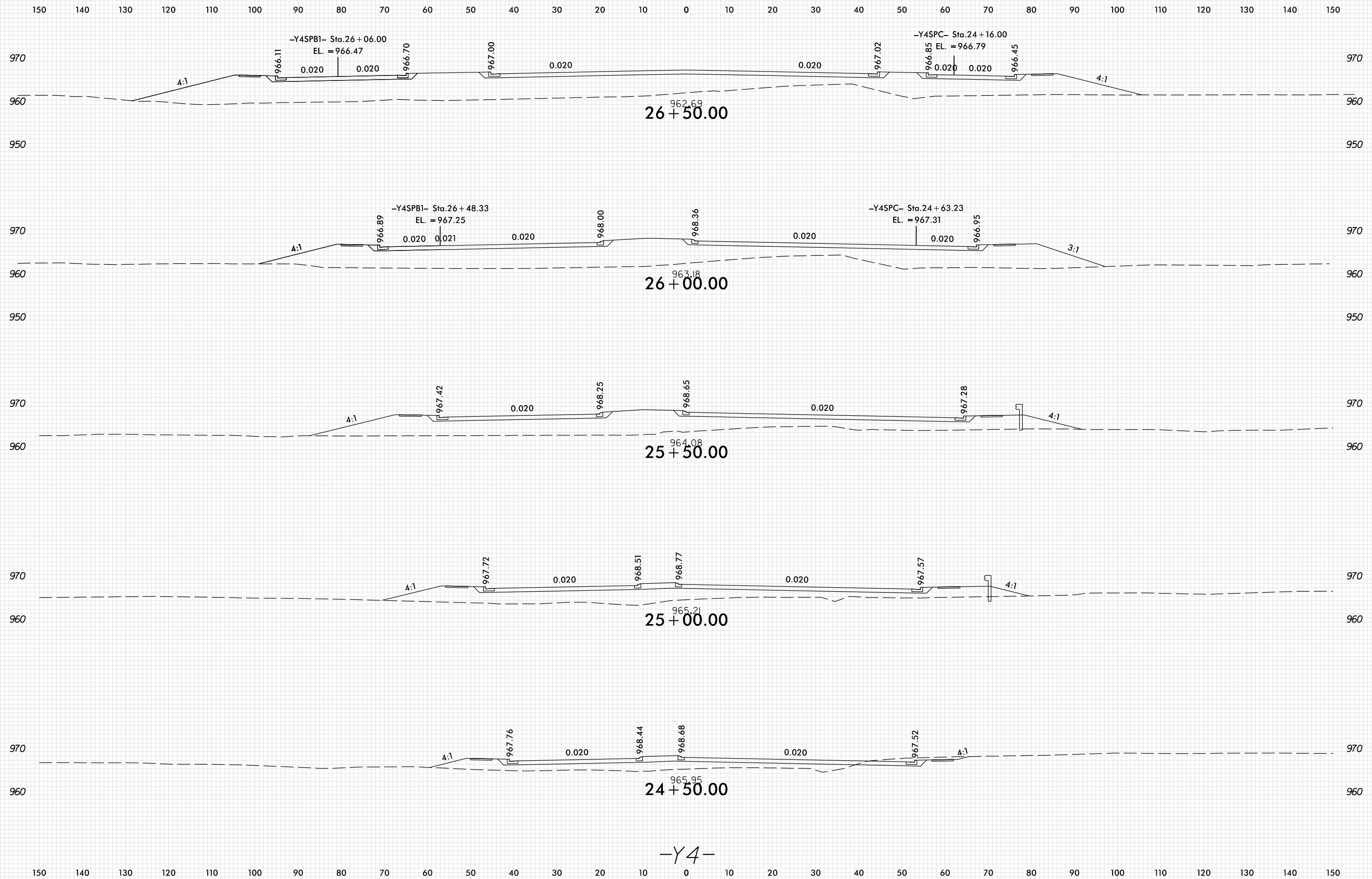

-Y4-

PLOT DRIVER: NCD01_color_eng_100.plt
 USER: SPEREIRA
 DATE: 6/10/2021
 TIME: 2:19:24 PM
 FILE: \

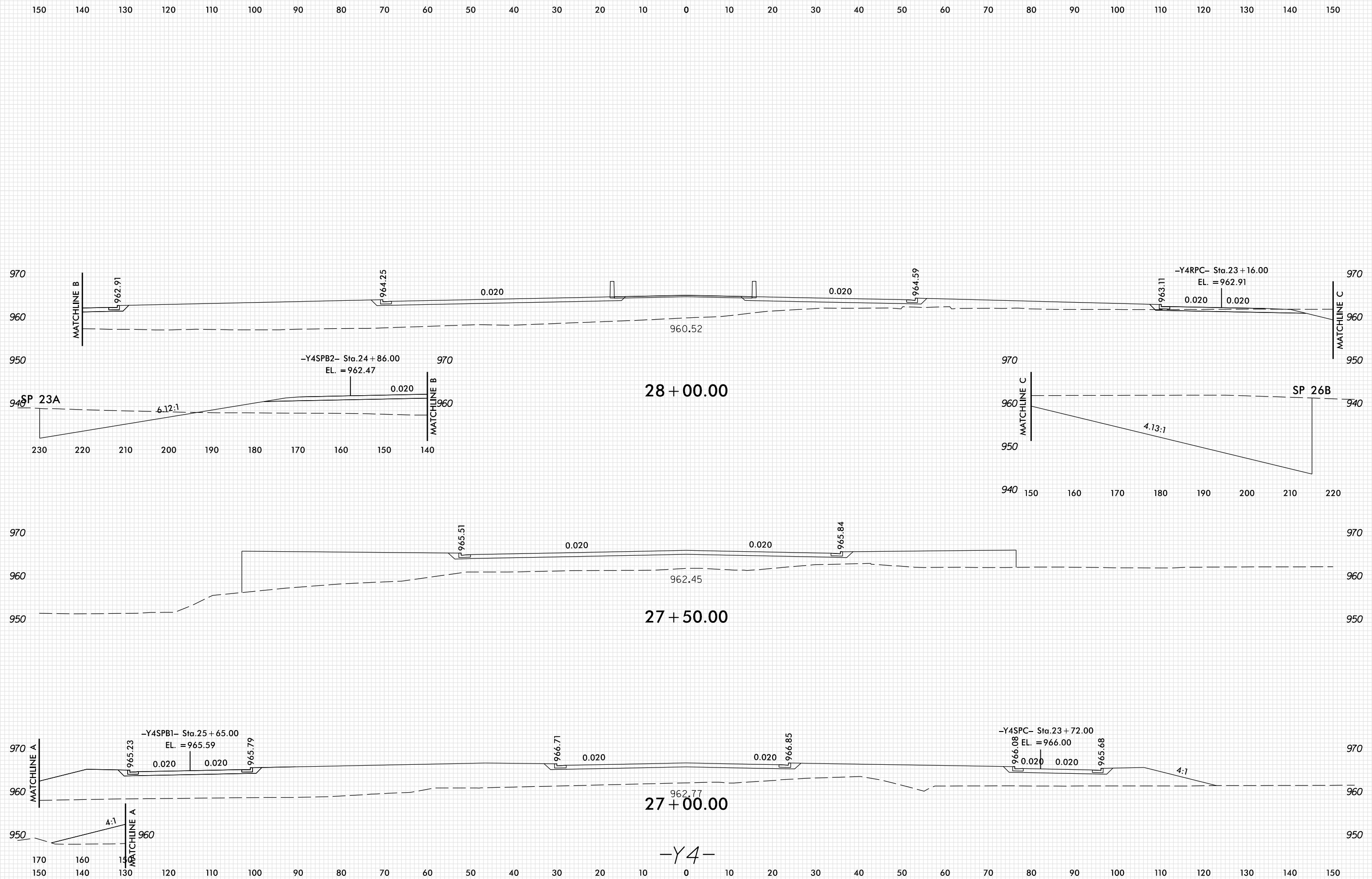

8/23/99

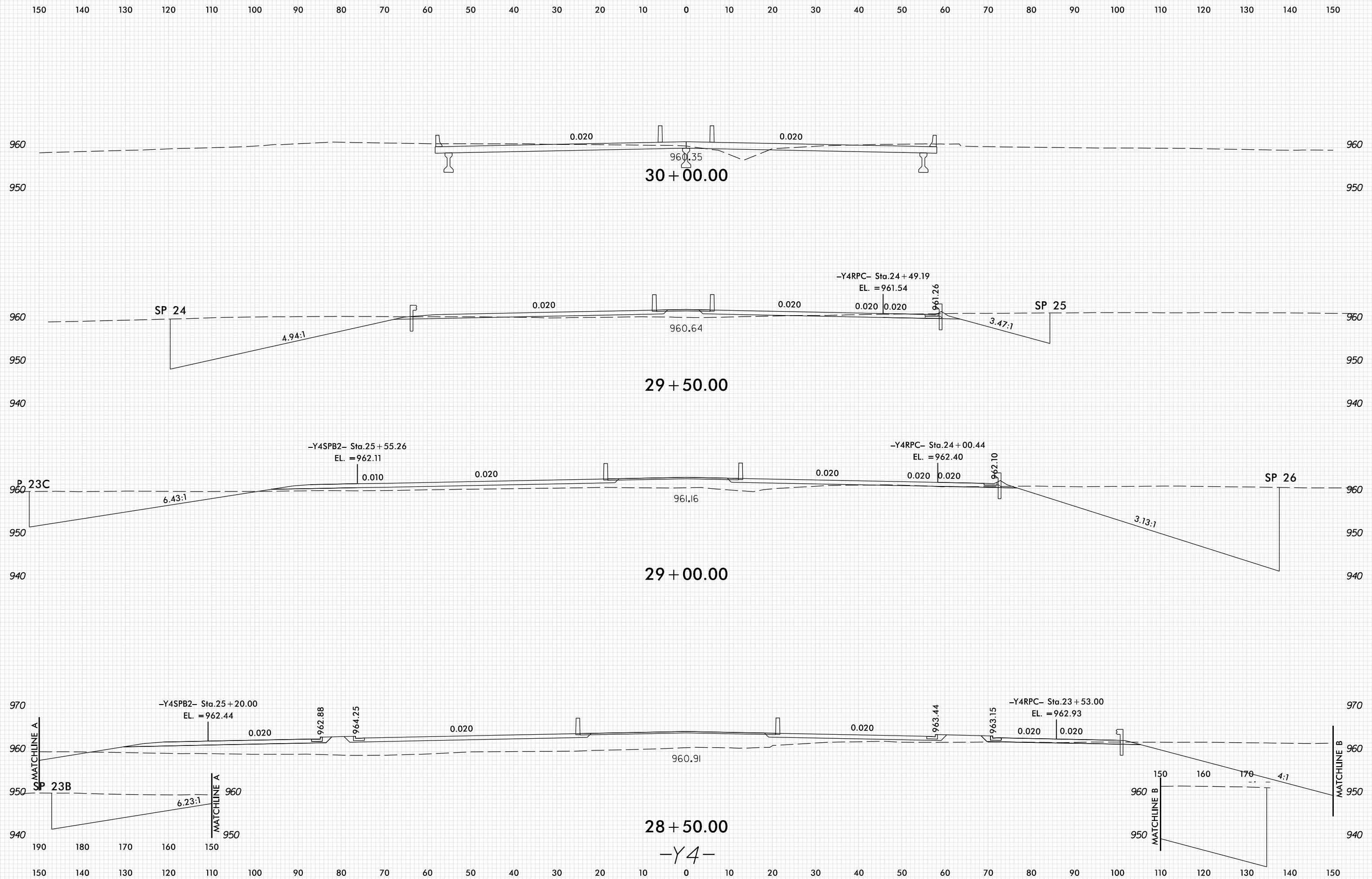

PLOT DRIVER: NCD01.pdf_color_eng_100.plt
 USER: SPEREIRA
 DATE: 6/10/2021
 TIME: 2:19:25 PM

8/23/99

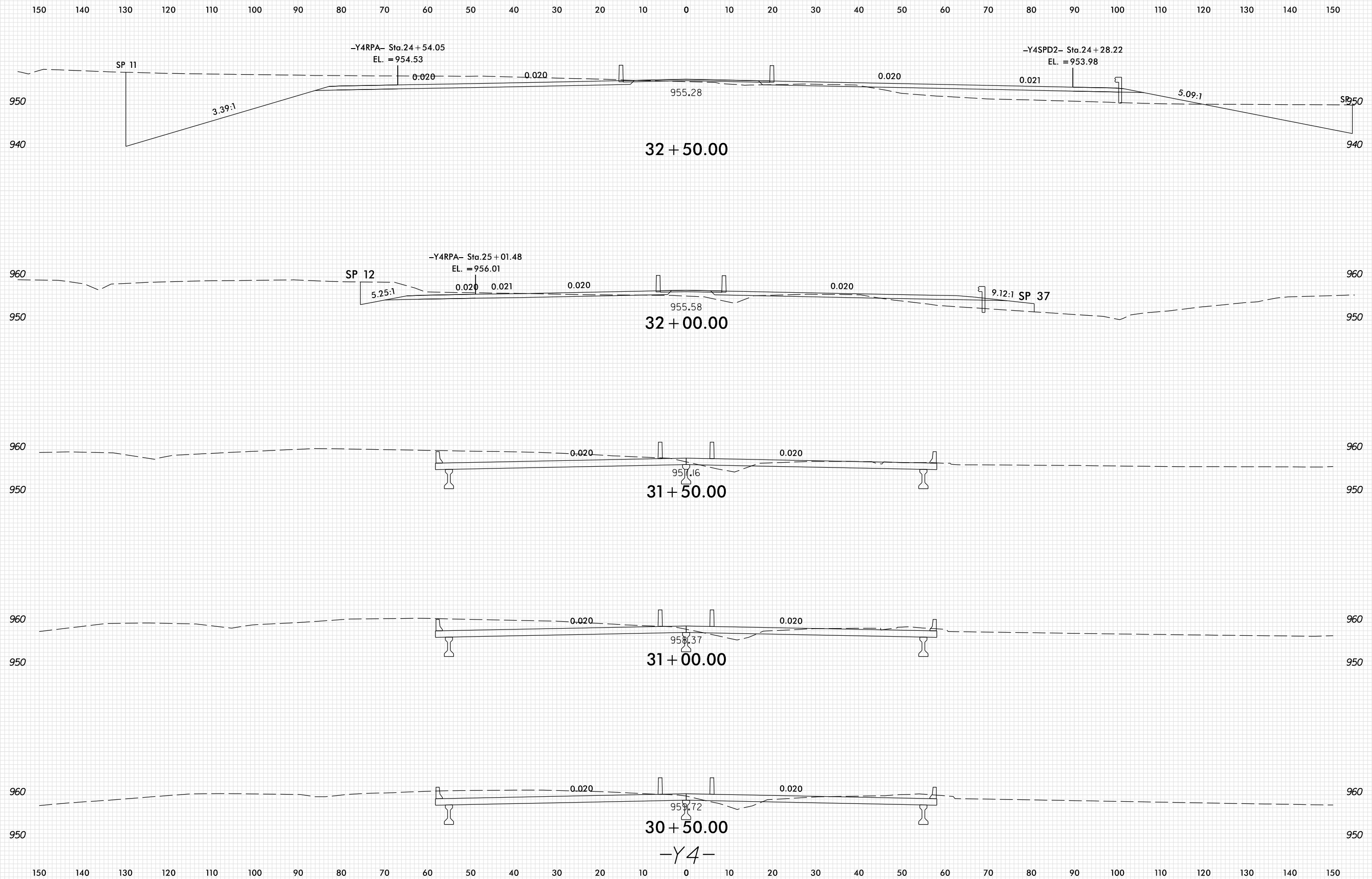

PLOT DRIVER: NCDOT_pdf_color_eng_100.plt
 USER: SPEREIRA
 DATE: 6/10/2021
 TIME: 2:19:26 PM
 FILE: \

8/23/99

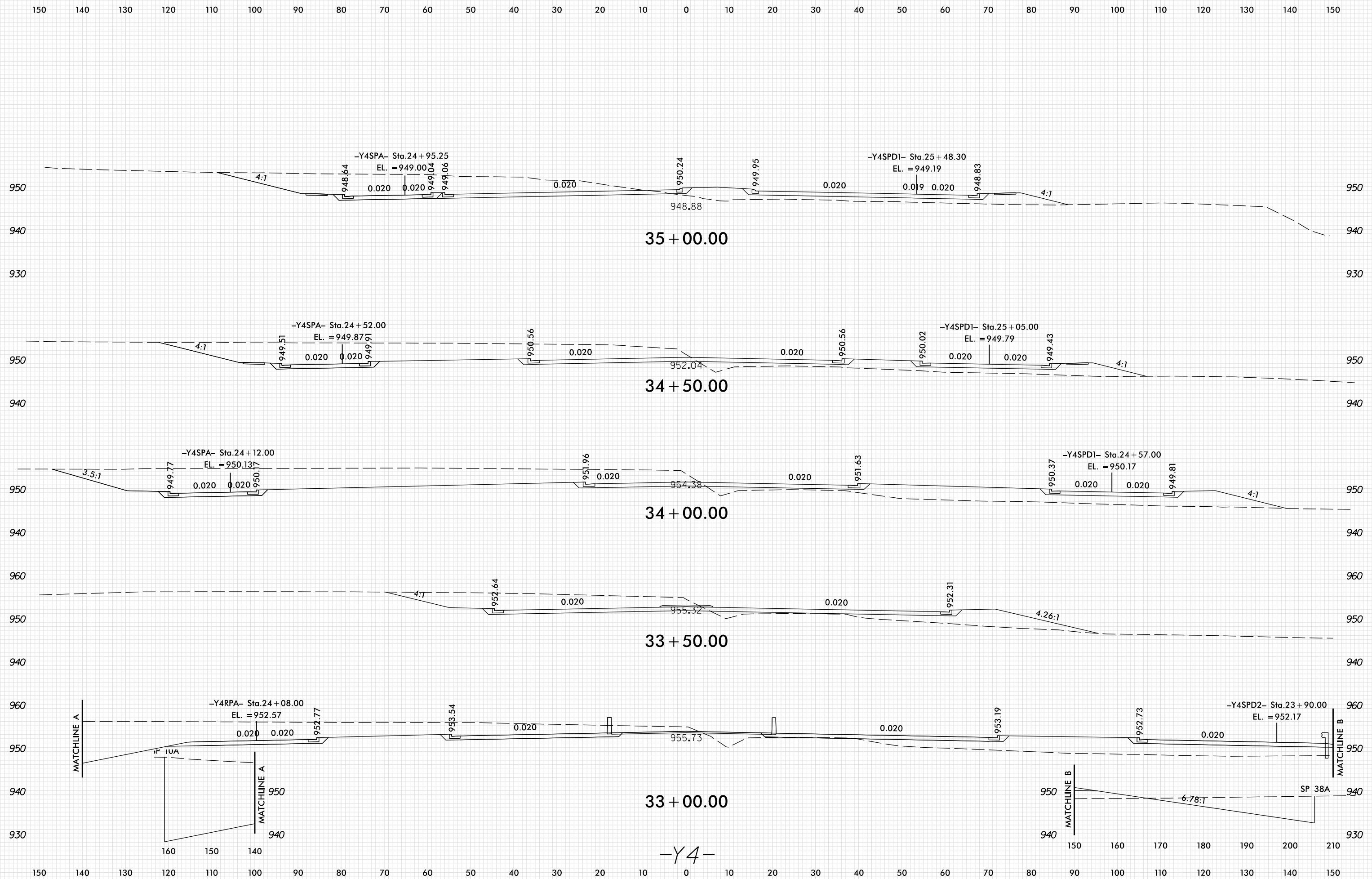

PLOT DRIVER: NCD01_pdf_color_eng_100.plt
 USER: SPEREIRA
 DATE: 6/10/2021
 TIME: 2:19:27 PM
 FILE: \

8/23/99

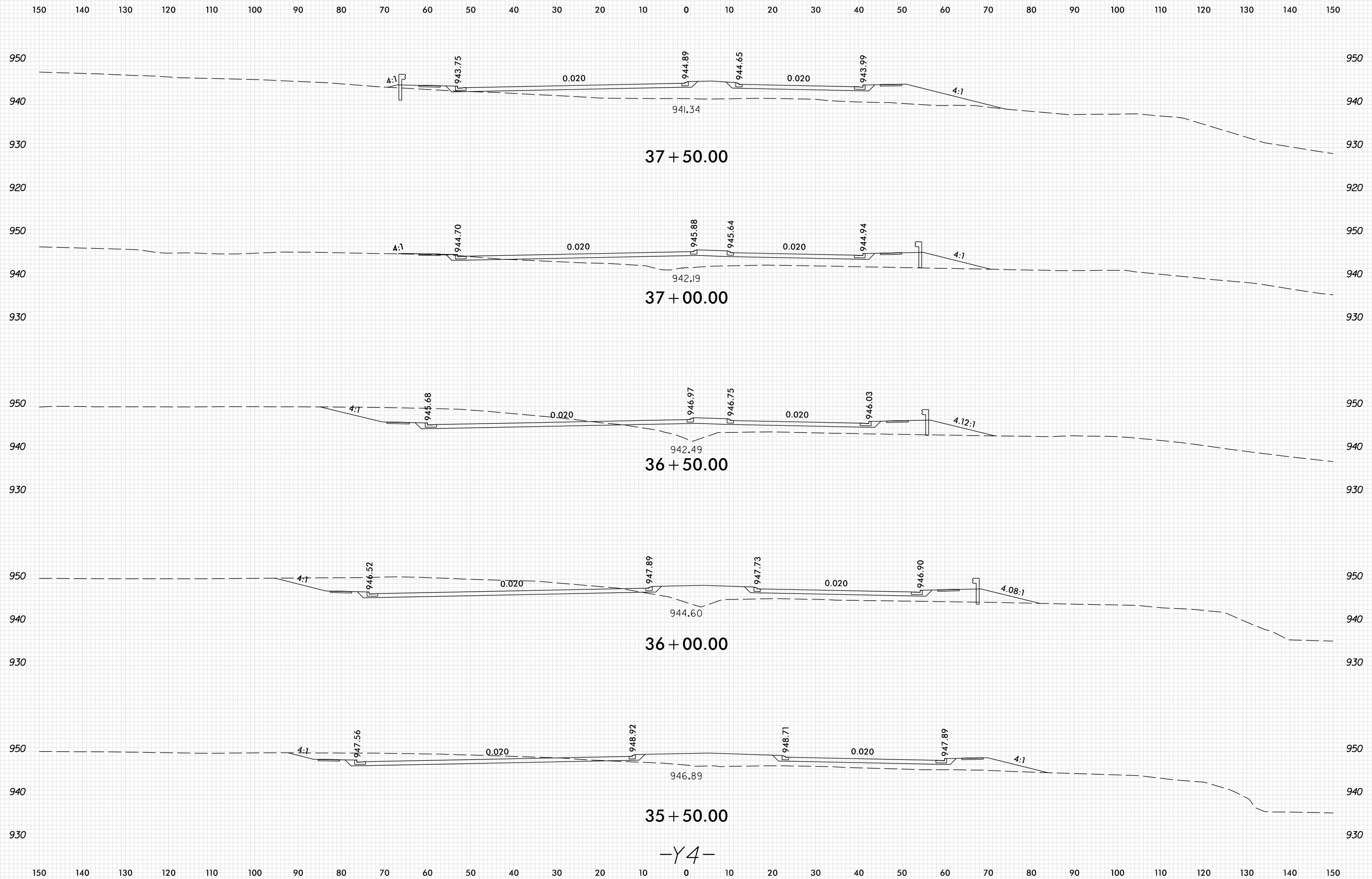

PLOT DRIVER: NCDOT_pdf_color_eng_100.plt
 USER: SPEREIRA
 DATE: 6/10/2021
 TIME: 2:19:27 PM
 FILE: \

-Y4-

8/23/99

0 5 10	PROJ. REFERENCE NO.	SHEET NO.
	U-2579AB	X-198

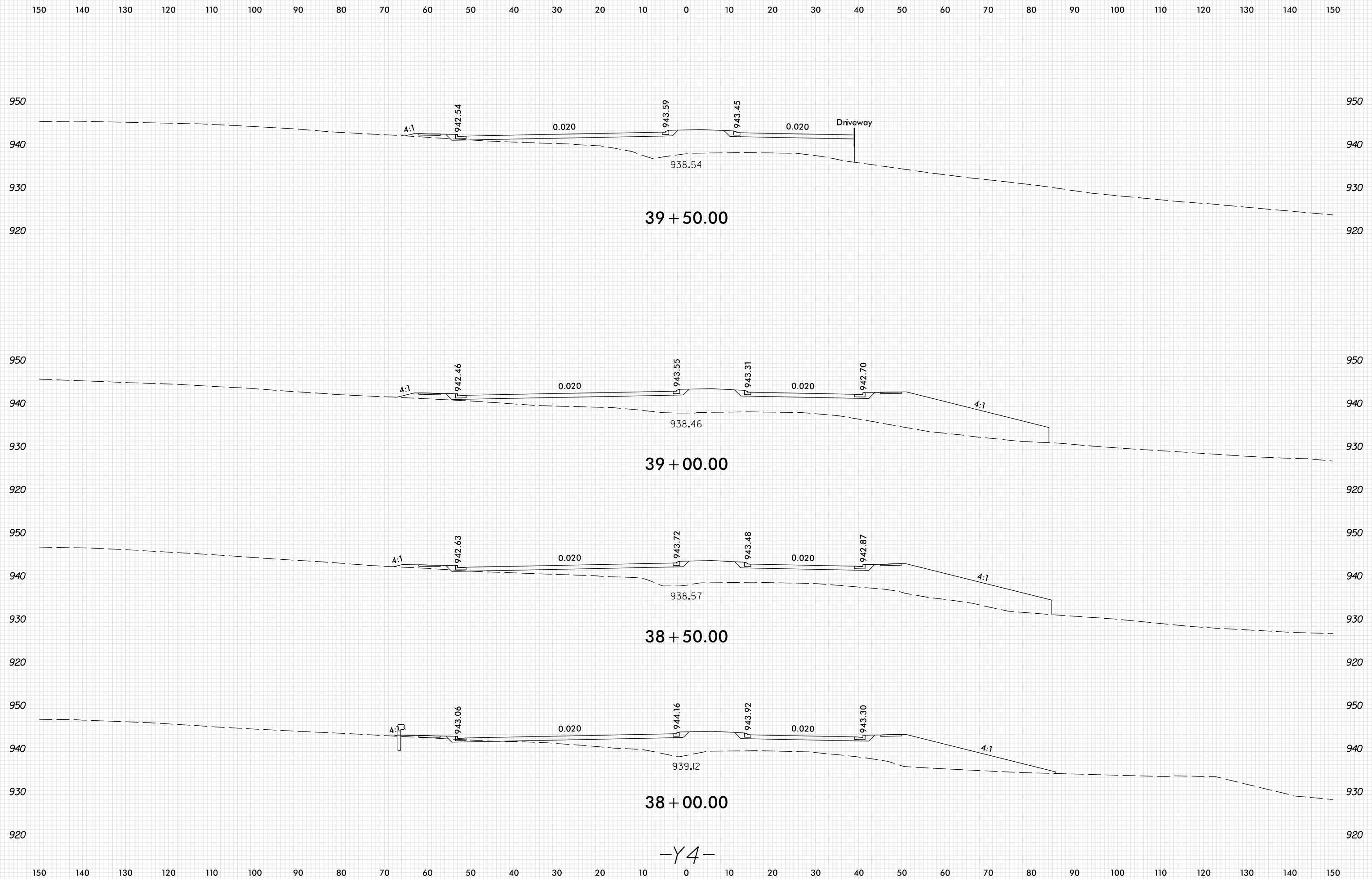

38 + 50.00

39 + 00.00

39 + 50.00

-Y4-

PLOT DRIVER: NCD01_pdf_color_eng_100.plt
 USER: SPEREIRA
 DATE: 6/10/2021
 TIME: 2:19:28 PM
 FILE: \

8/23/99

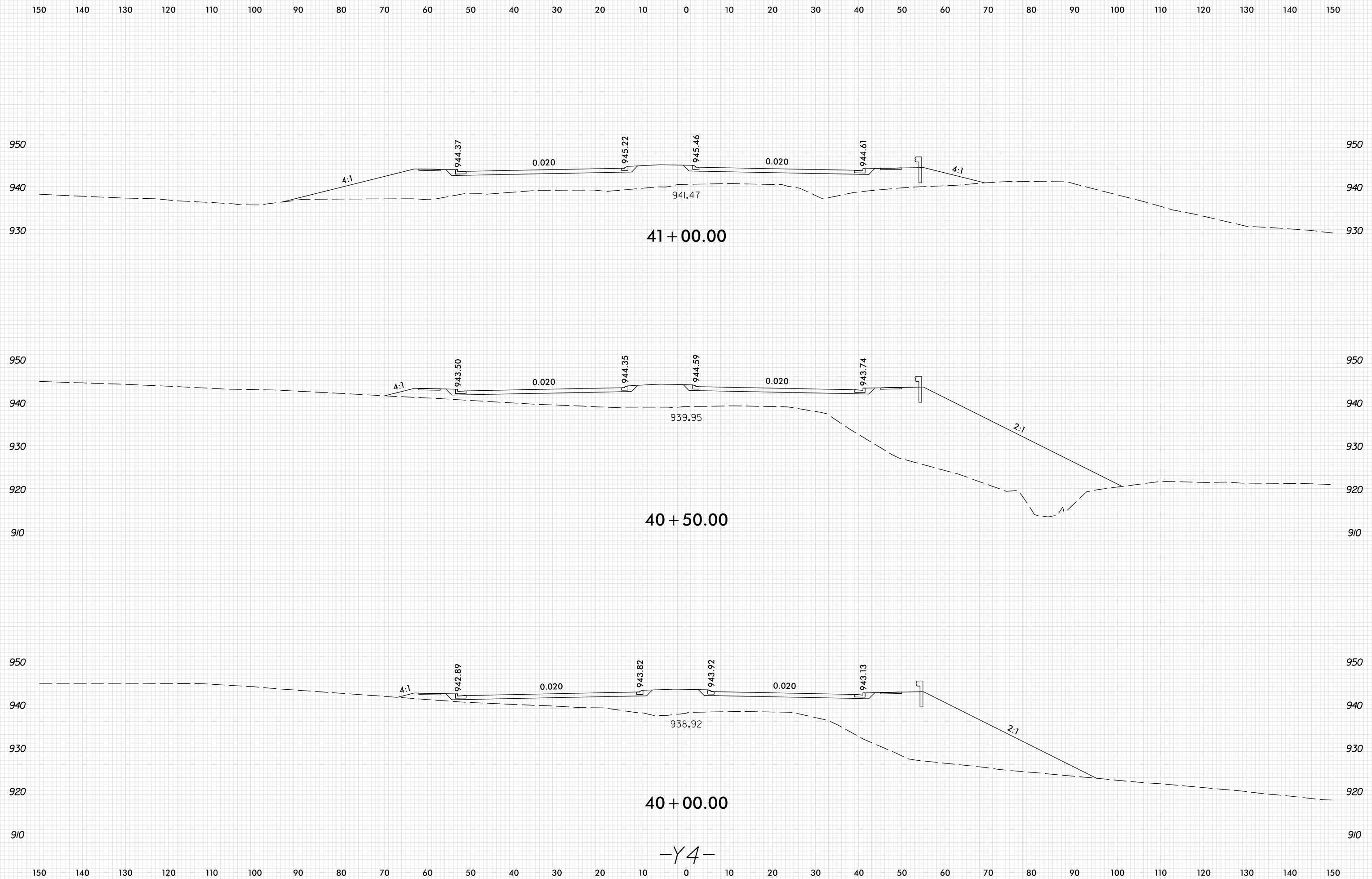

-Y4-

PLOT DRIVER: NCD01_pdf_color_eng_100.plt
 USER: SPEREIRA
 FILE: \PENTABLE: xpl_en_v8.tbl
 DATE: 6/10/2021
 TIME: 2:19:28 PM

8/23/99



PROJ. REFERENCE NO.	SHEET NO.
U-2579AB	X-200

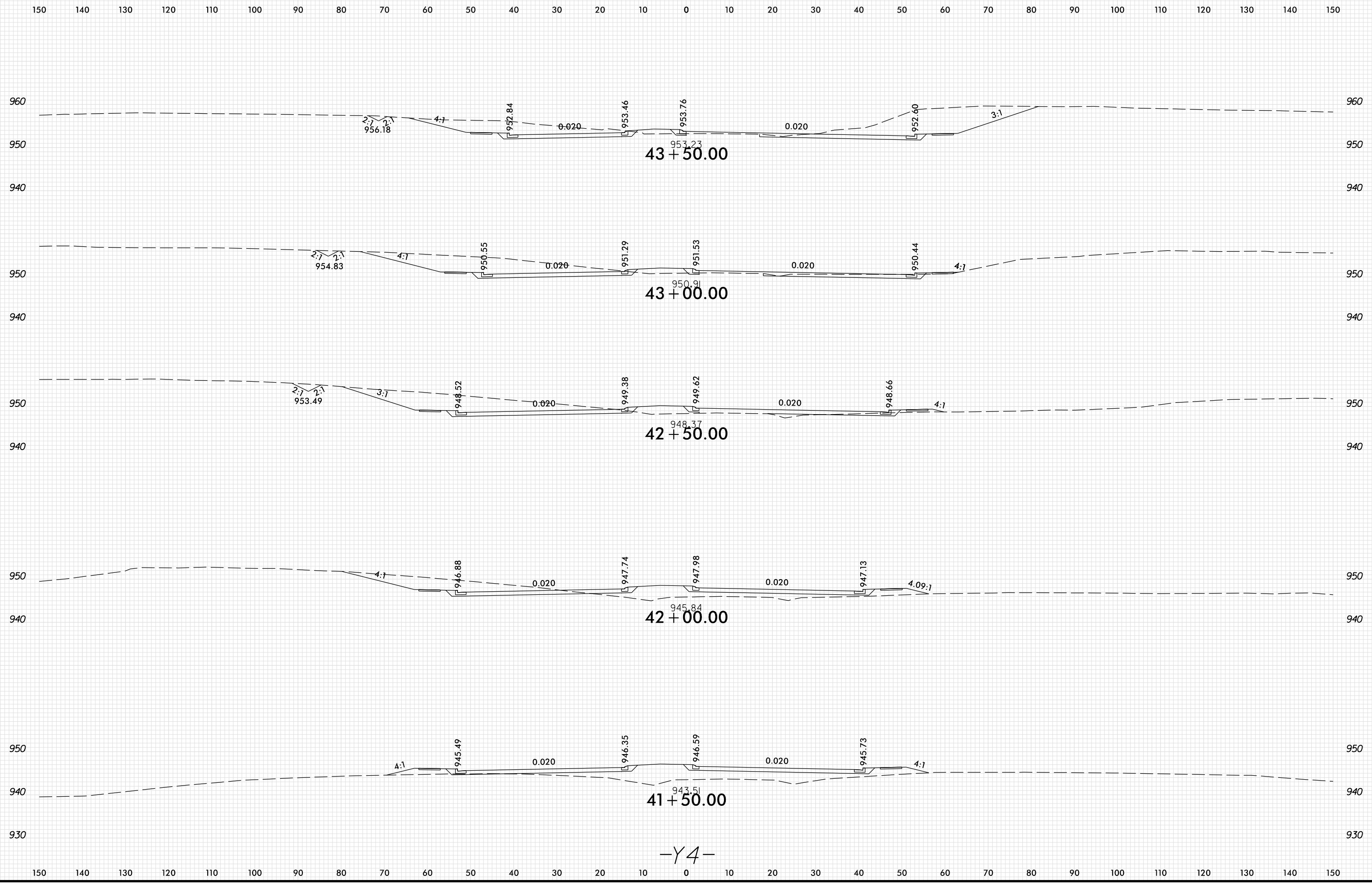

-Y4-

PLOT DRIVER: NCD01_pdf_color_eng_100.plt
 USER: SPEREIRA
 DATE: 6/10/2021
 TIME: 2:19:29 PM
 FILE: \

8/23/99

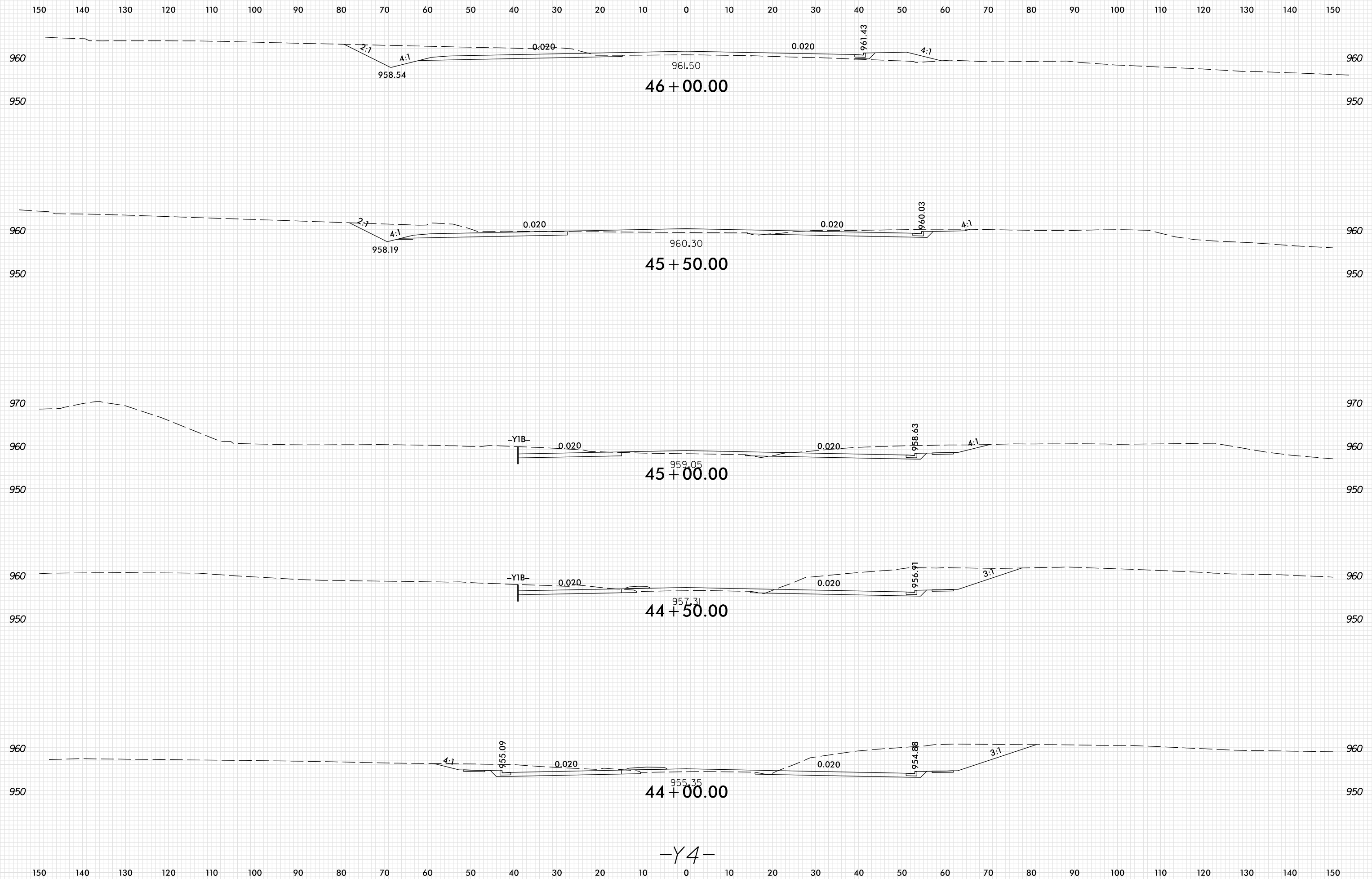

-Y4-

PLOT DRIVER: NCD01_pdf_color_eng_100.plt
 USER: SPEREIRA
 DATE: 6/10/2021
 TIME: 2:19:30 PM
 FILE: \

8/23/99

0 5 10	PROJ. REFERENCE NO.	SHEET NO.
	U-2579AB	X-202

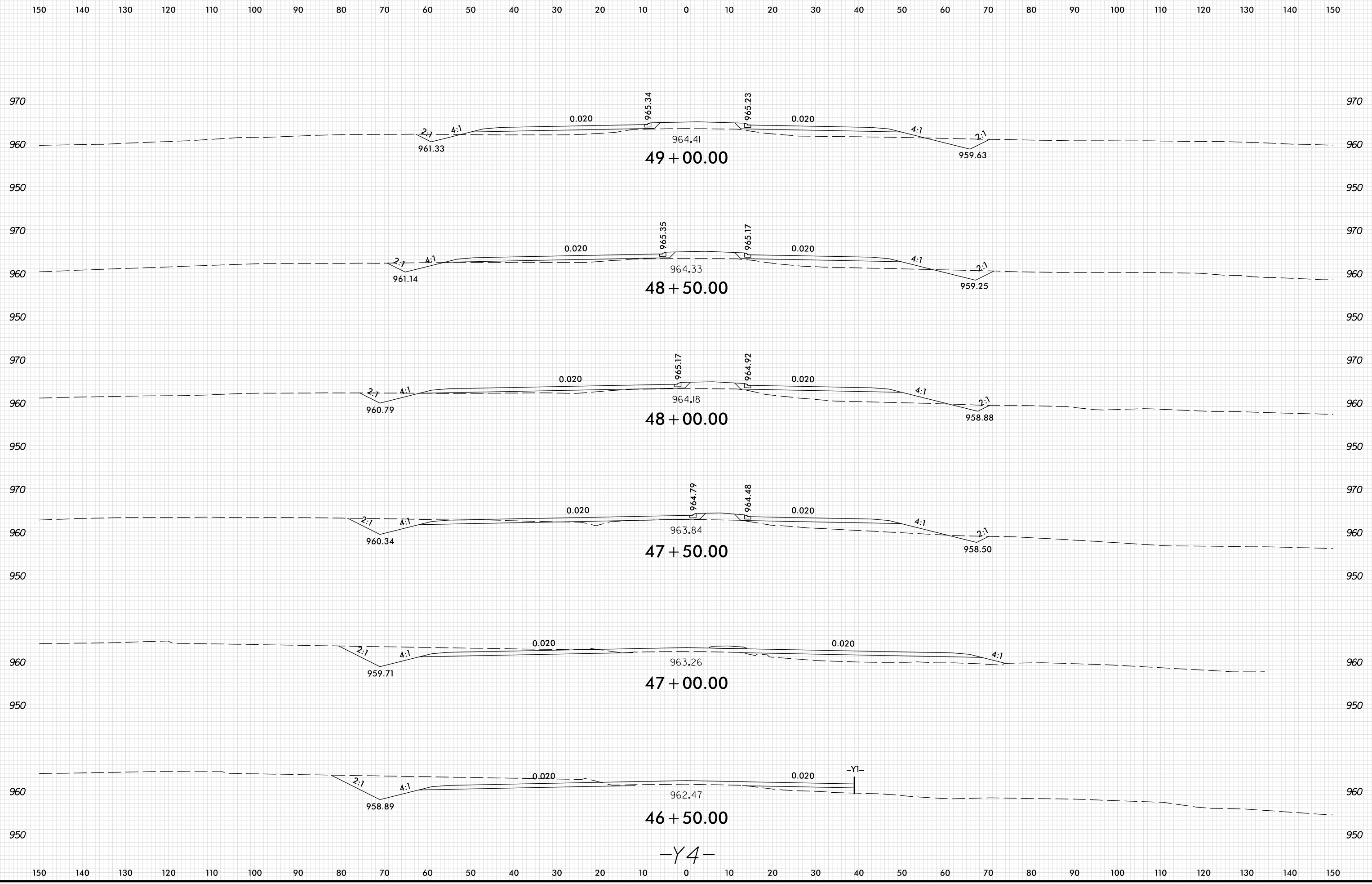

PLOT DRIVER: NCDOT_pdf_color_eng_100.plt
 USER: SPEREIRA
 DATE: 6/10/2021
 TIME: 2:19:30 PM
 FILE: \

8/23/99

0 5 10	PROJ. REFERENCE NO.	SHEET NO.
	U-2579AB	X-203

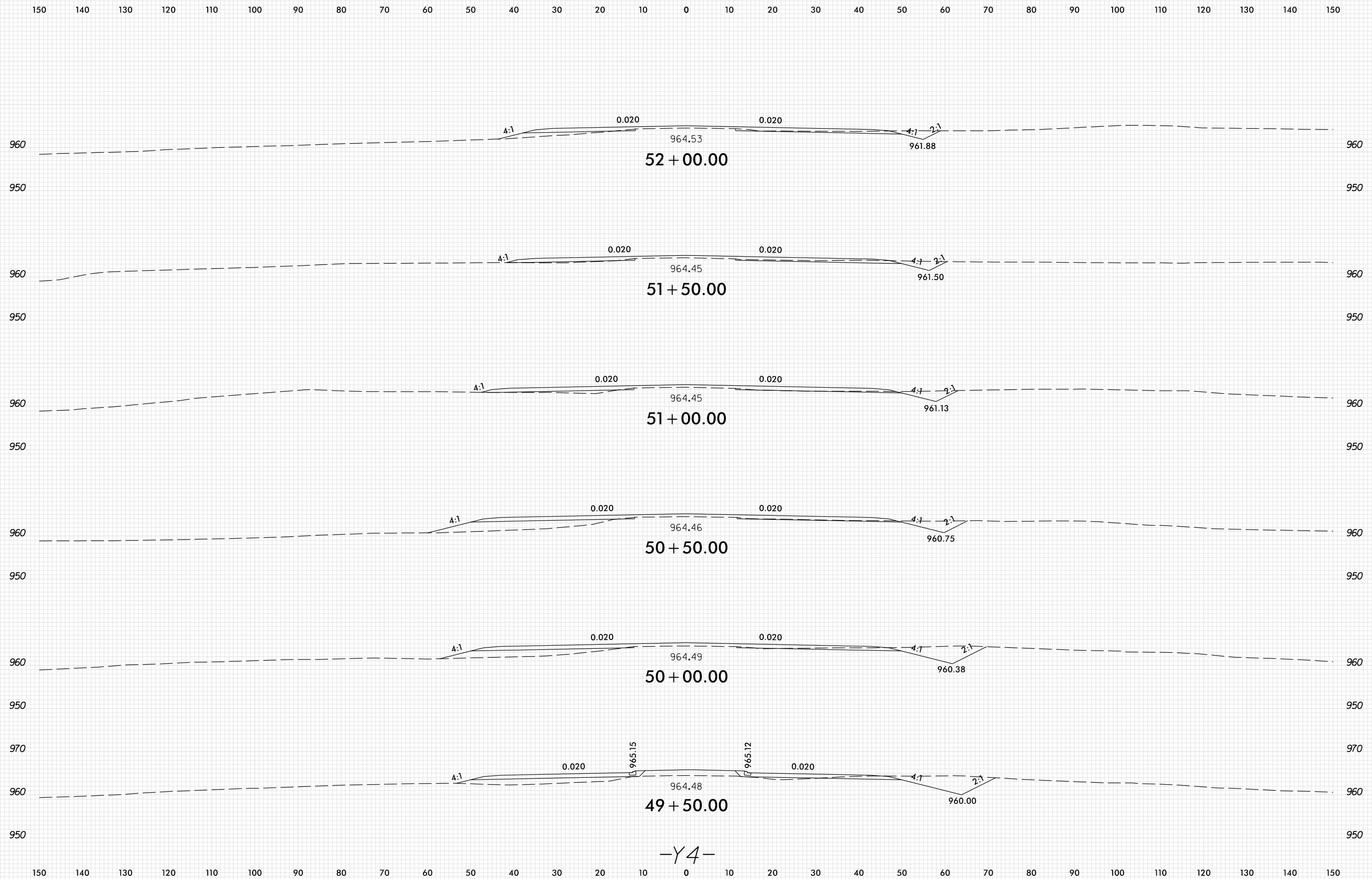

-Y4-

PLOT DRIVER: NCDOT_pdf_color_eng_100.plt
 USER: SPEREIRA
 DATE: 6/10/2021
 TIME: 2:19:31 PM
 FILE: \

8/23/99

0 5 10	PROJ. REFERENCE NO.	SHEET NO.
	U-2579AB	X-204

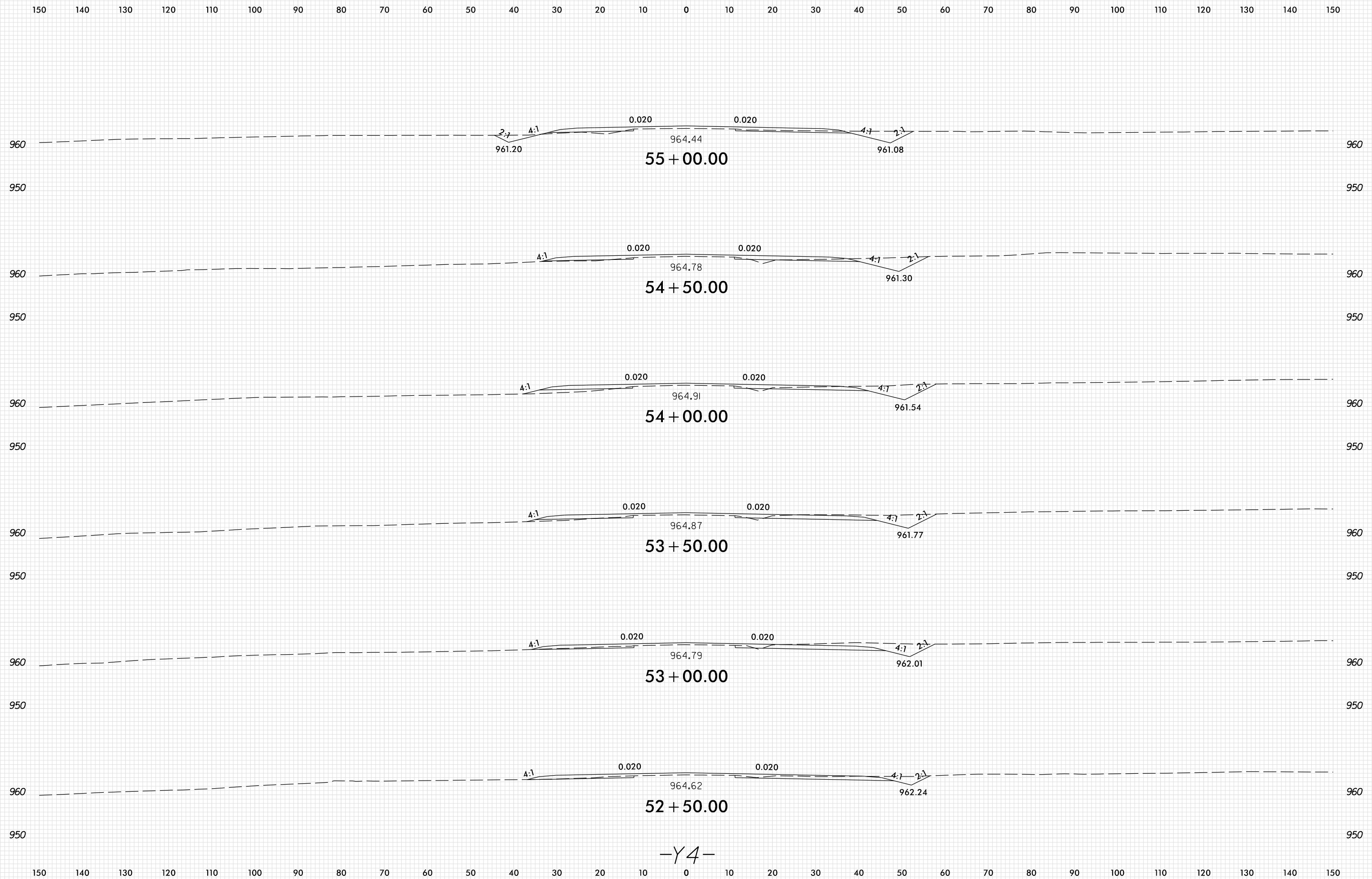

PLOT DRIVER: NCDOT_pdf_color_eng_100.plt
 USER: SPEREIRA
 DATE: 6/10/2021
 TIME: 2:19:32 PM
 FILE: \

-Y4-

8/23/99

0 5 10	PROJ. REFERENCE NO.	SHEET NO.
	U-2579AB	X-205

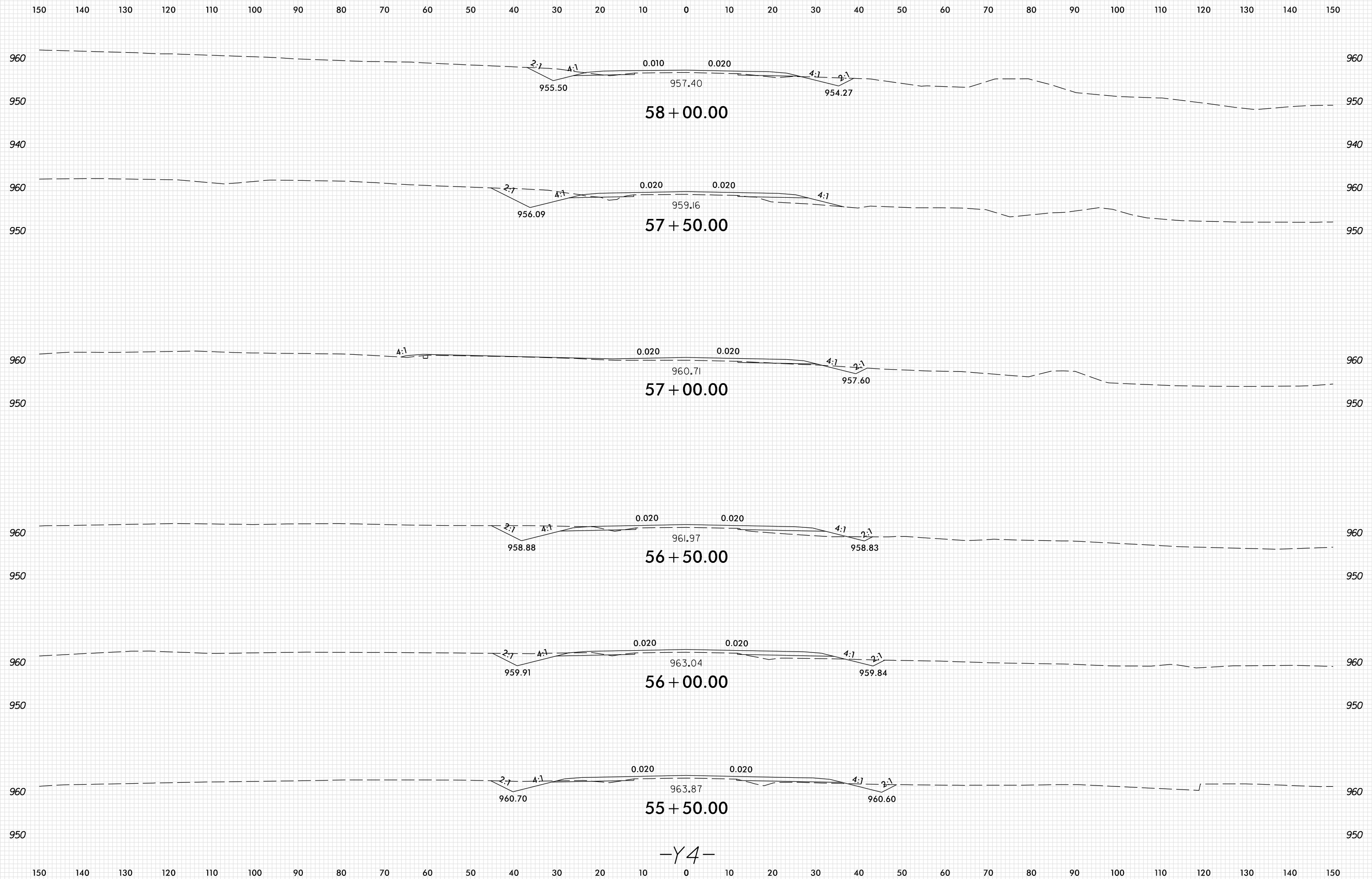

-Y4-

PLOT DRIVER: NCDOT_pdf_color_eng_100.plt
 USER: SPEREIRA
 DATE: 6/10/2021
 TIME: 2:19:32 PM
 FILE: \

8/23/99



PROJ. REFERENCE NO.	SHEET NO.
U-2579AB	X-206

150 140 130 120 110 100 90 80 70 60 50 40 30 20 10 0 10 20 30 40 50 60 70 80 90 100 110 120 130 140 150

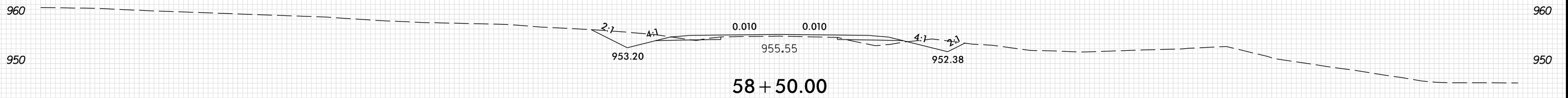
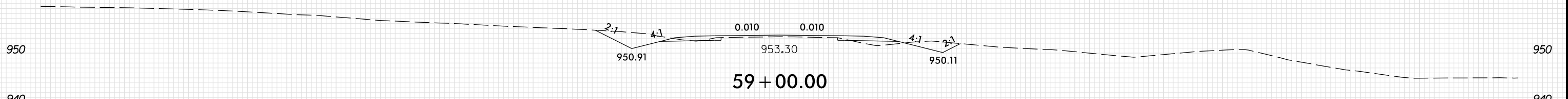
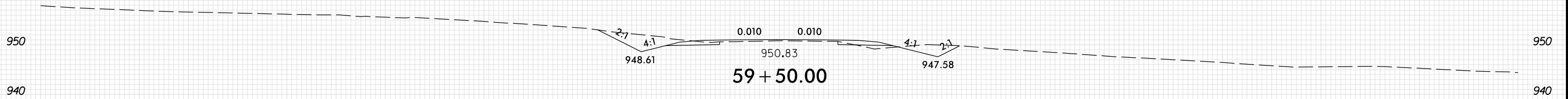
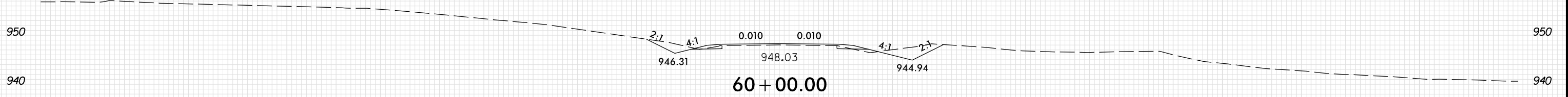

-Y4-

150 140 130 120 110 100 90 80 70 60 50 40 30 20 10 0 10 20 30 40 50 60 70 80 90 100 110 120 130 140 150

PLOT DRIVER: NCD01_pdf_color_eng_100.plt
USER: SPEREIRA
DATE: 6/10/2021
TIME: 2:19:33 PM
FILE: \

8/23/99

0 5 10	PROJ. REFERENCE NO.	SHEET NO.
	U-2579AB	X-207

150 140 130 120 110 100 90 80 70 60 50 40 30 20 10 0 10 20 30 40 50 60 70 80 90 100 110 120 130 140 150

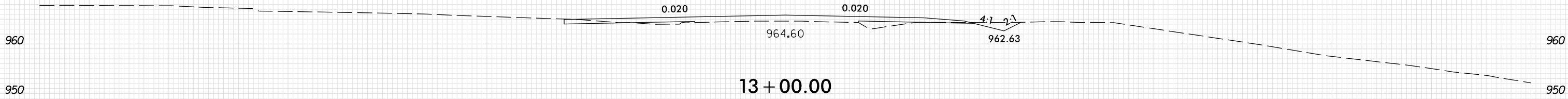

13 + 00.00

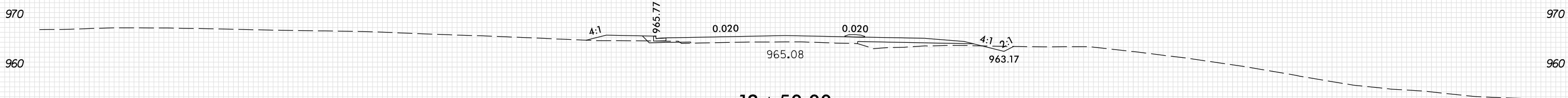

12 + 50.00

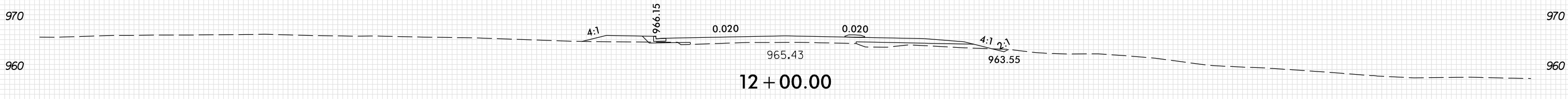

12 + 00.00

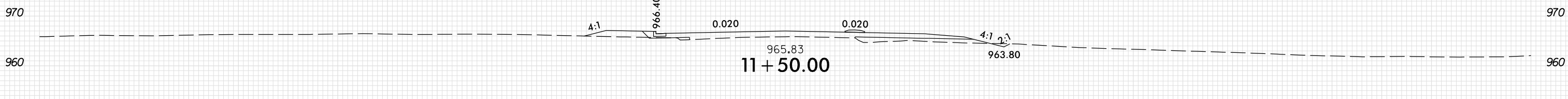

11 + 50.00

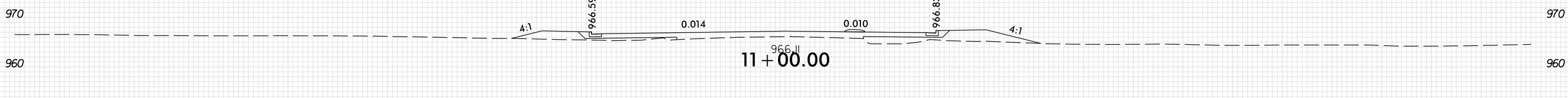

11 + 00.00

-Y4A-

150 140 130 120 110 100 90 80 70 60 50 40 30 20 10 0 10 20 30 40 50 60 70 80 90 100 110 120 130 140 150

PLOT DRIVER: NCDOT_pdf_color_eng_100.plt
 USER: SPEREIRA
 DATE: 6/10/2021
 TIME: 2:19:43 PM
 FILE: \

8/23/99



PROJ. REFERENCE NO.	SHEET NO.
U-2579AB	X-208

150 140 130 120 110 100 90 80 70 60 50 40 30 20 10 0 10 20 30 40 50 60 70 80 90 100 110 120 130 140 150

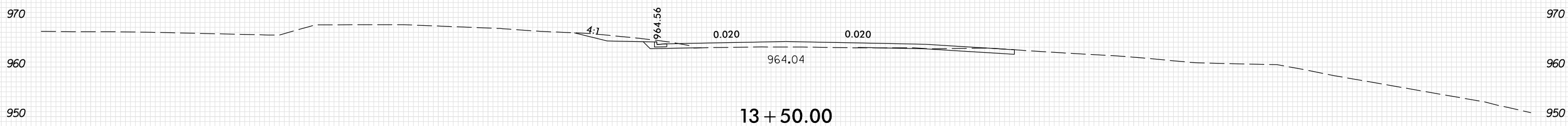
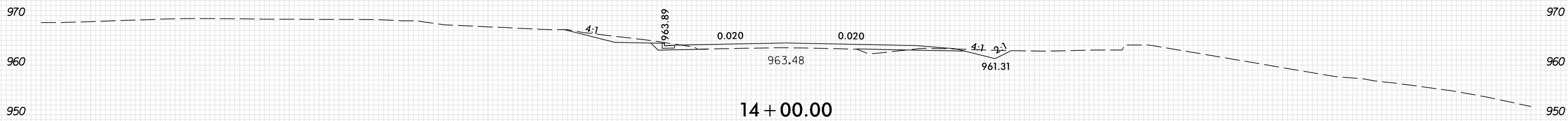
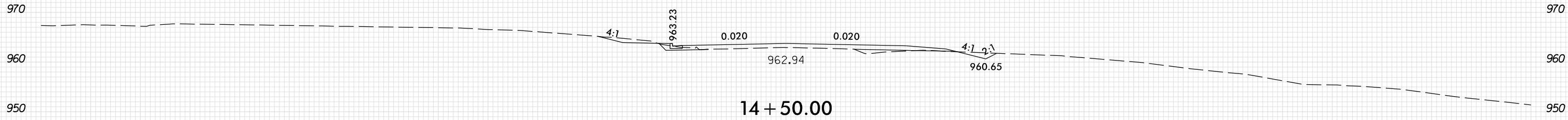
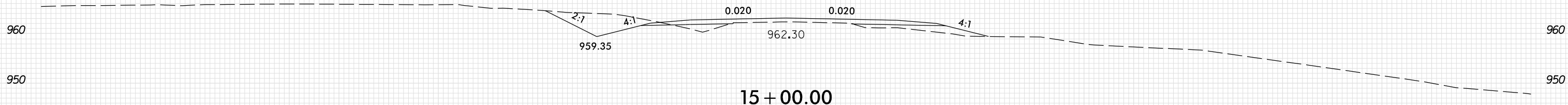

-Y4A-

150 140 130 120 110 100 90 80 70 60 50 40 30 20 10 0 10 20 30 40 50 60 70 80 90 100 110 120 130 140 150

PLOT DRIVER: NCD01_pdf_color_eng_100.plt
 USER: SPEREIRA
 DATE: 6/10/2021
 TIME: 2:19:44 PM

8/23/99

0 5 10	PROJ. REFERENCE NO.	SHEET NO.
	U-2579AB	X-209

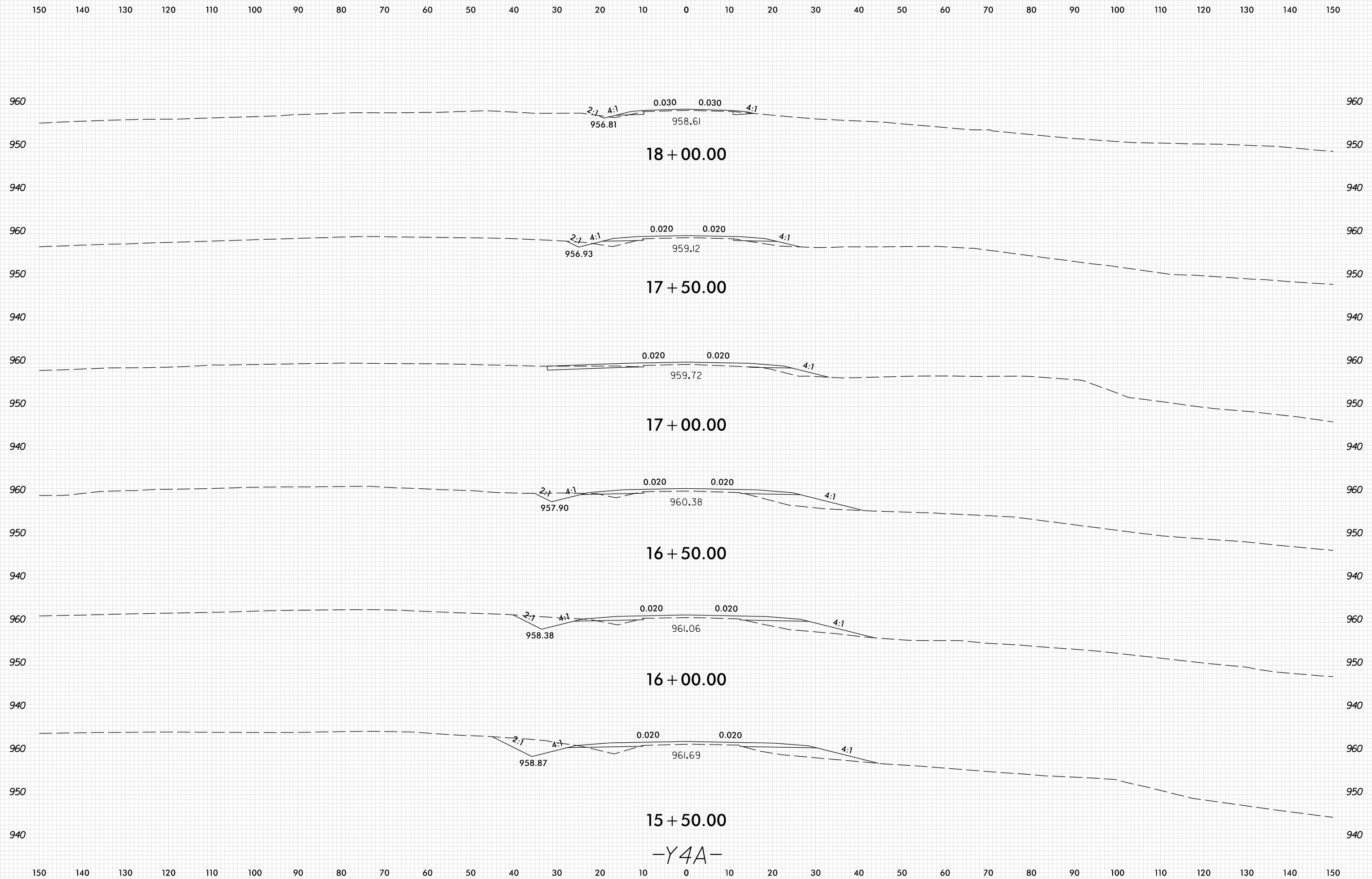

PLOT DRIVER: NCDOT_pdf_color_eng_100.plt
 USER: SPEREIRA
 DATE: 6/10/2021
 TIME: 2:19:44 PM
 FILE: \

-Y4A-

8/23/99



PROJ. REFERENCE NO.	SHEET NO.
U-2579AB	X-210

190 180 170 160 150 140 130 120 110 100 90 80 70 60 50 40 30 20 10 0 10 20 30 40 50 60 70 80 90 100 110

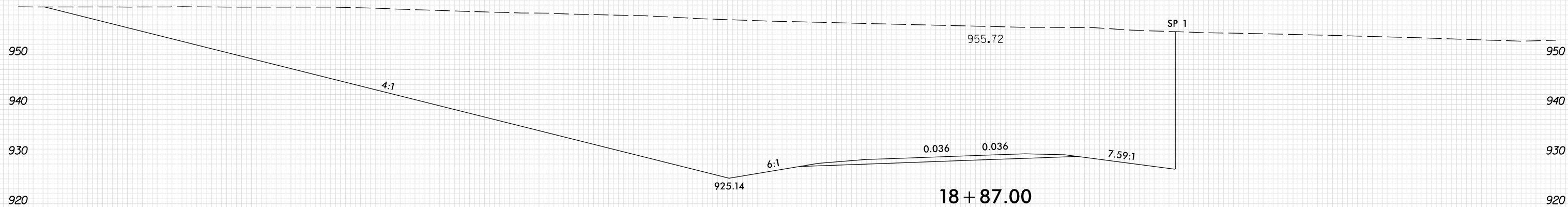
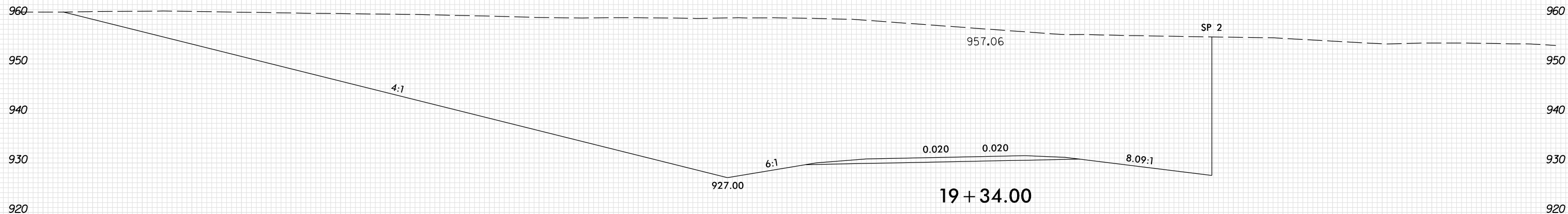

-Y4RPA-

190 180 170 160 150 140 130 120 110 100 90 80 70 60 50 40 30 20 10 0 10 20 30 40 50 60 70 80 90 100 110

PLOT DRIVER: NCD01_pdf_color_eng_100.plt
 USER: SPEREIRA DATE: 6/10/2021 TIME: 2:19:53 PM
 FILE: \

8/23/99

0 5 10	PROJ. REFERENCE NO.	SHEET NO.
	U-2579AB	X-211

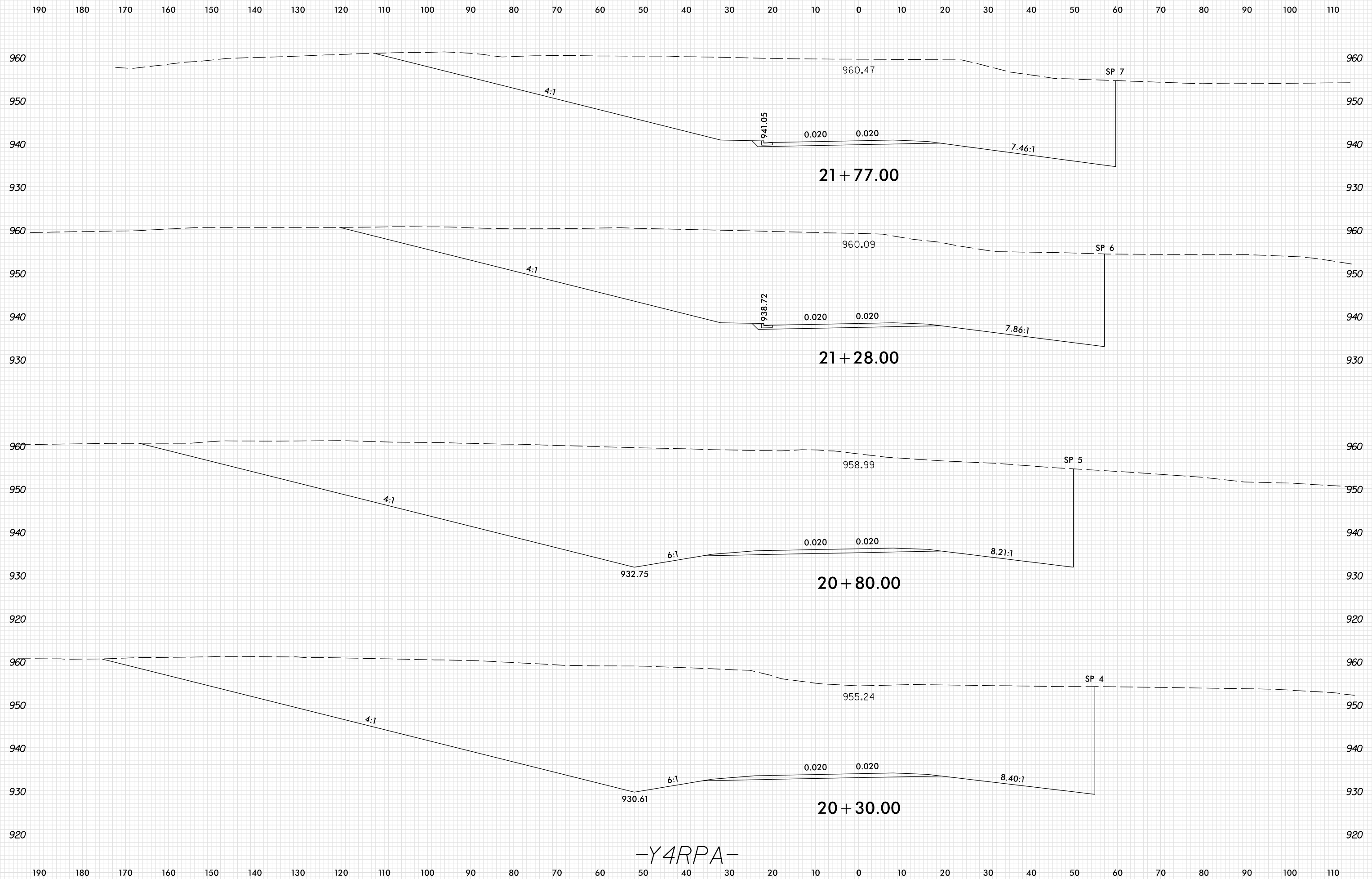

-Y4RPA-

PLOT DRIVER: NCDOT_pdf_color_eng_100.plt
 USER: SPEREIRA
 DATE: 6/10/2021
 TIME: 2:19:54 PM
 FILE: \

8/23/99

190 180 170 160 150 140 130 120 110 100 90 80 70 60 50 40 30 20 10 0 10 20 30 40 50 60 70 80 90 100 110

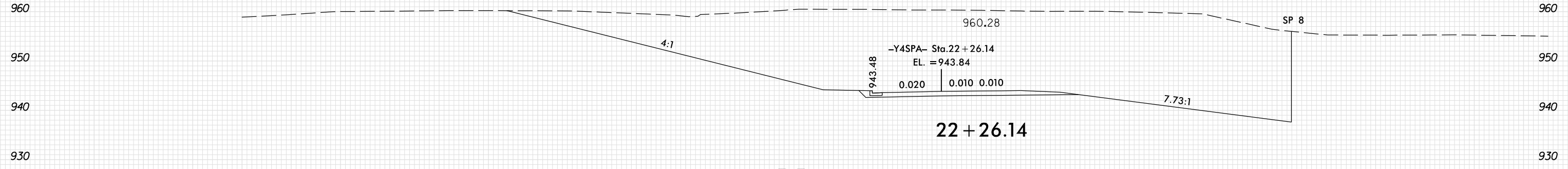
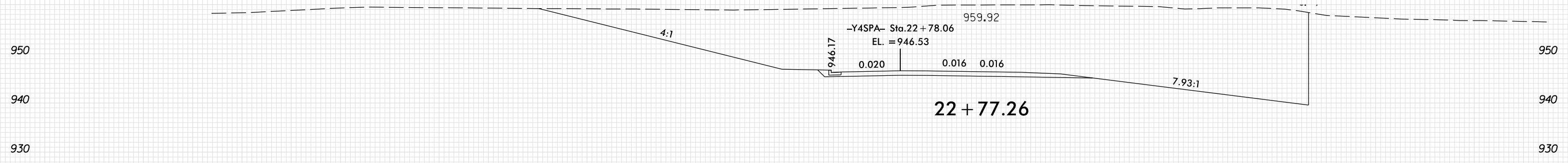
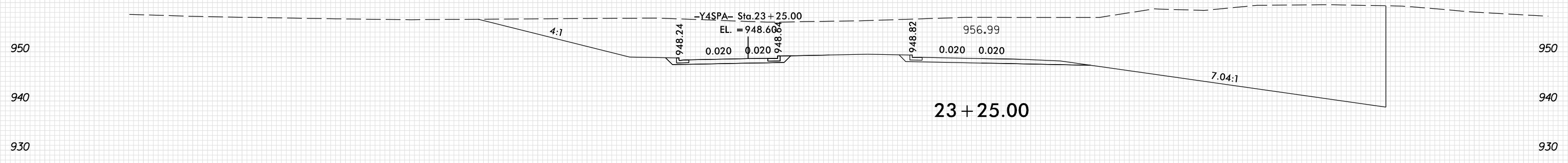
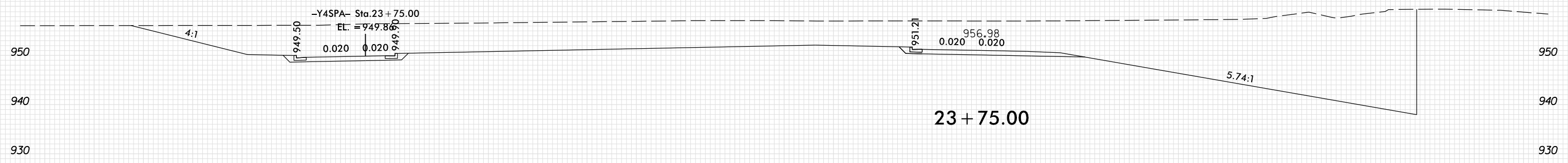

-Y4RPA-

190 180 170 160 150 140 130 120 110 100 90 80 70 60 50 40 30 20 10 0 10 20 30 40 50 60 70 80 90 100 110

PLOT DRIVER: NCD01_pdf_color_eng_100.plt
 USER: SPEREIRA
 DATE: 6/10/2021
 TIME: 2:19:54 PM
 FILE: \

8/23/99

0 5 10	PROJ. REFERENCE NO.	SHEET NO.
	U-2579AB	X-213

150 140 130 120 110 100 90 80 70 60 50 40 30 20 10 0 10 20 30 40 50 60 70 80 90 100 110 120 130 140 150

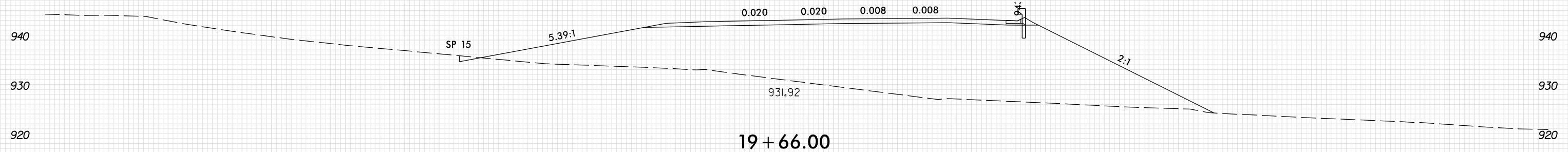

19 + 66.00



19 + 15.00

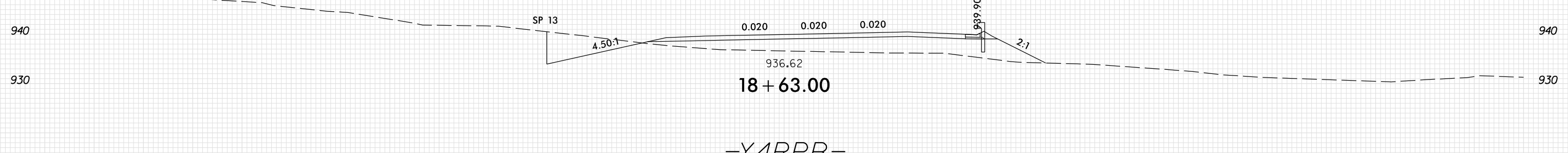

18 + 63.00

-Y4RPB-

150 140 130 120 110 100 90 80 70 60 50 40 30 20 10 0 10 20 30 40 50 60 70 80 90 100 110 120 130 140 150

PLOT DRIVER: NCDOT_pdf_color_eng_100.plt
 USER: SPEREIRA
 DATE: 6/10/2021
 TIME: 2:20:02 PM
 FILE: \

8/23/99

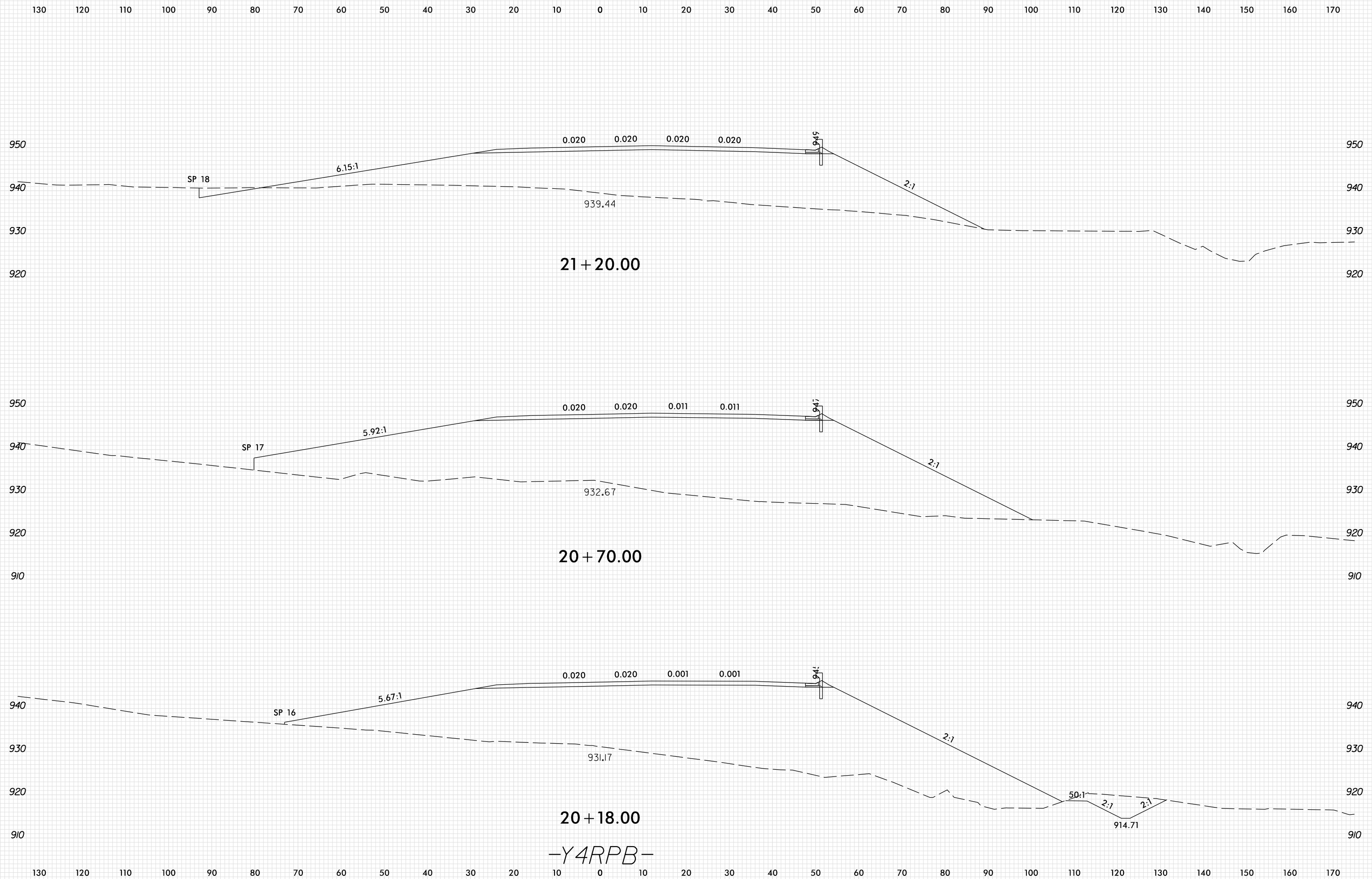

21 + 20.00

20 + 70.00

20 + 18.00

-Y4RPB-

PLOT DRIVER: NCDOT_pdf_color_eng_100.plt
 USER: SPEREIRA
 DATE: 6/10/2021
 TIME: 2:20:02 PM
 FILE: \

8/23/99



PROJ. REFERENCE NO. U-2579AB	SHEET NO. X-215
---------------------------------	--------------------

150 140 130 120 110 100 90 80 70 60 50 40 30 20 10 0 10 20 30 40 50 60 70 80 90 100 110 120 130 140 150

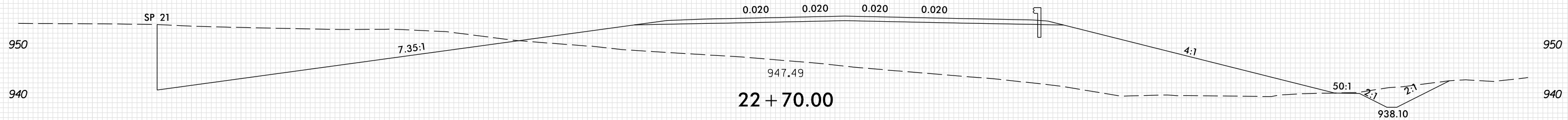

22 + 70.00

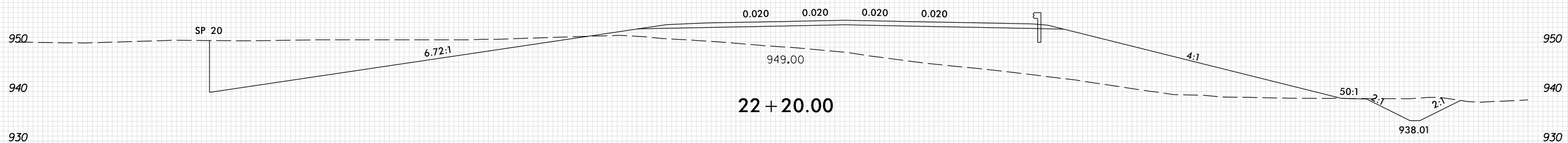

22 + 20.00



21 + 70.00

-Y4RPB-

150 140 130 120 110 100 90 80 70 60 50 40 30 20 10 0 10 20 30 40 50 60 70 80 90 100 110 120 130 140 150

PLOT DRIVER: NCDOT_pdf_color_eng_100.plt
 USER: SPEREIRA
 DATE: 6/10/2021
 TIME: 2:20:03 PM
 FILE: \

200 190 180 170 160 150 140 130 120 110 100 90 80 70 60 50 40 30 20 10 0 10 20 30 40 50 60 70 80 90 100

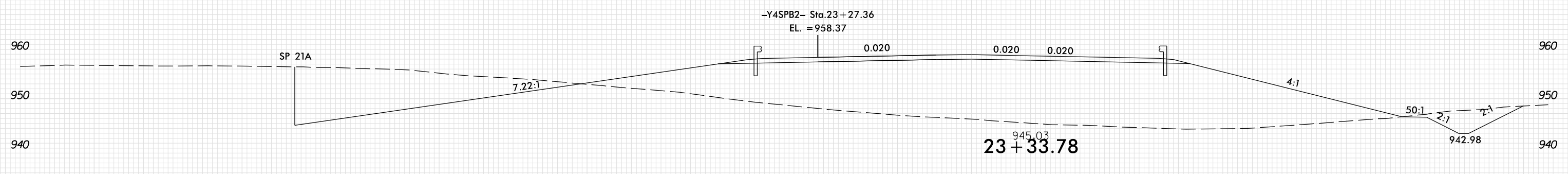
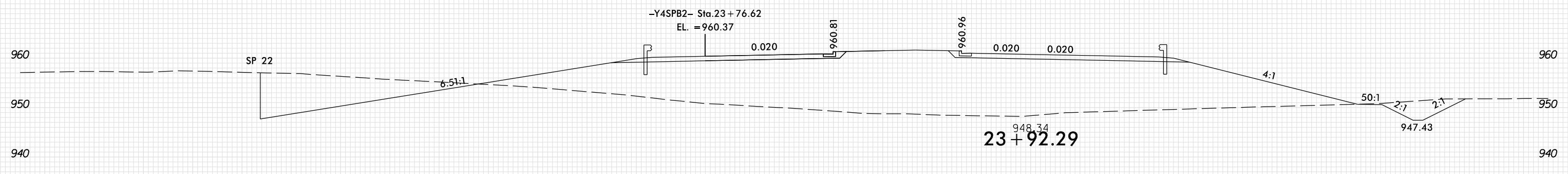

-Y4SPBI-

200 190 180 170 160 150 140 130 120 110 100 90 80 70 60 50 40 30 20 10 0 10 20 30 40 50 60 70 80 90 100

150 140 130 120 110 100 90 80 70 60 50 40 30 20 10 0 10 20 30 40 50 60 70 80 90 100 110 120 130 140 150

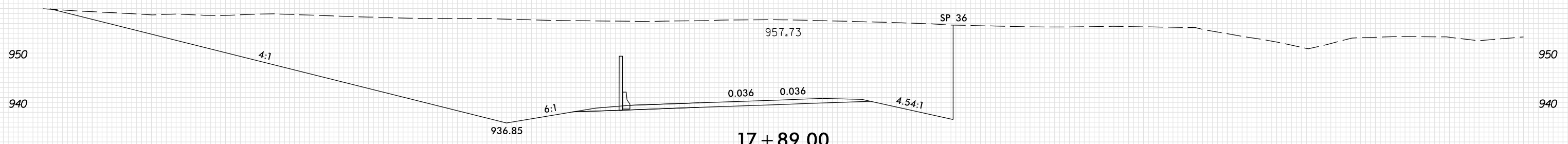
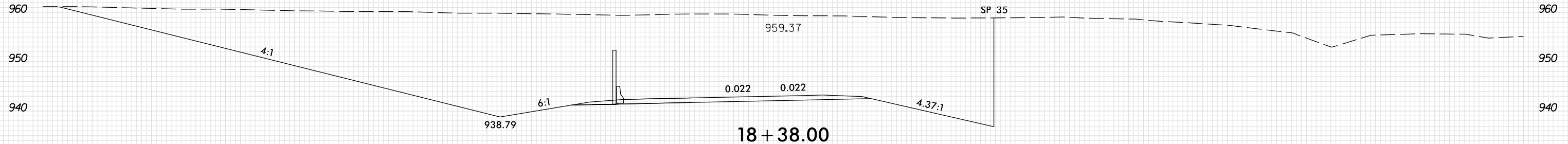
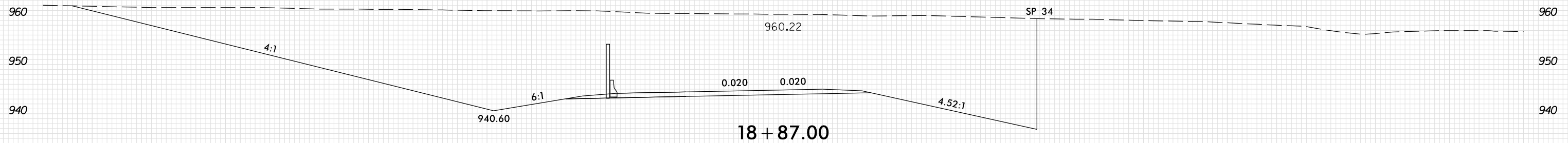
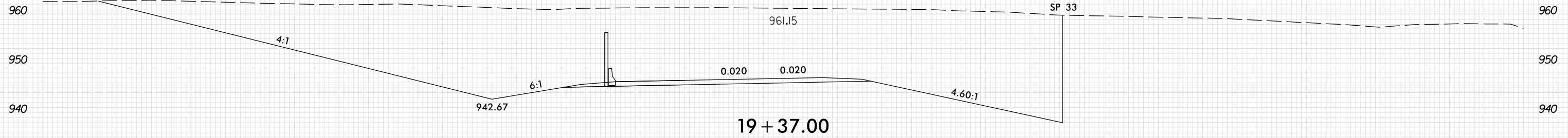

-Y4RPC-

150 140 130 120 110 100 90 80 70 60 50 40 30 20 10 0 10 20 30 40 50 60 70 80 90 100 110 120 130 140 150

8/23/99

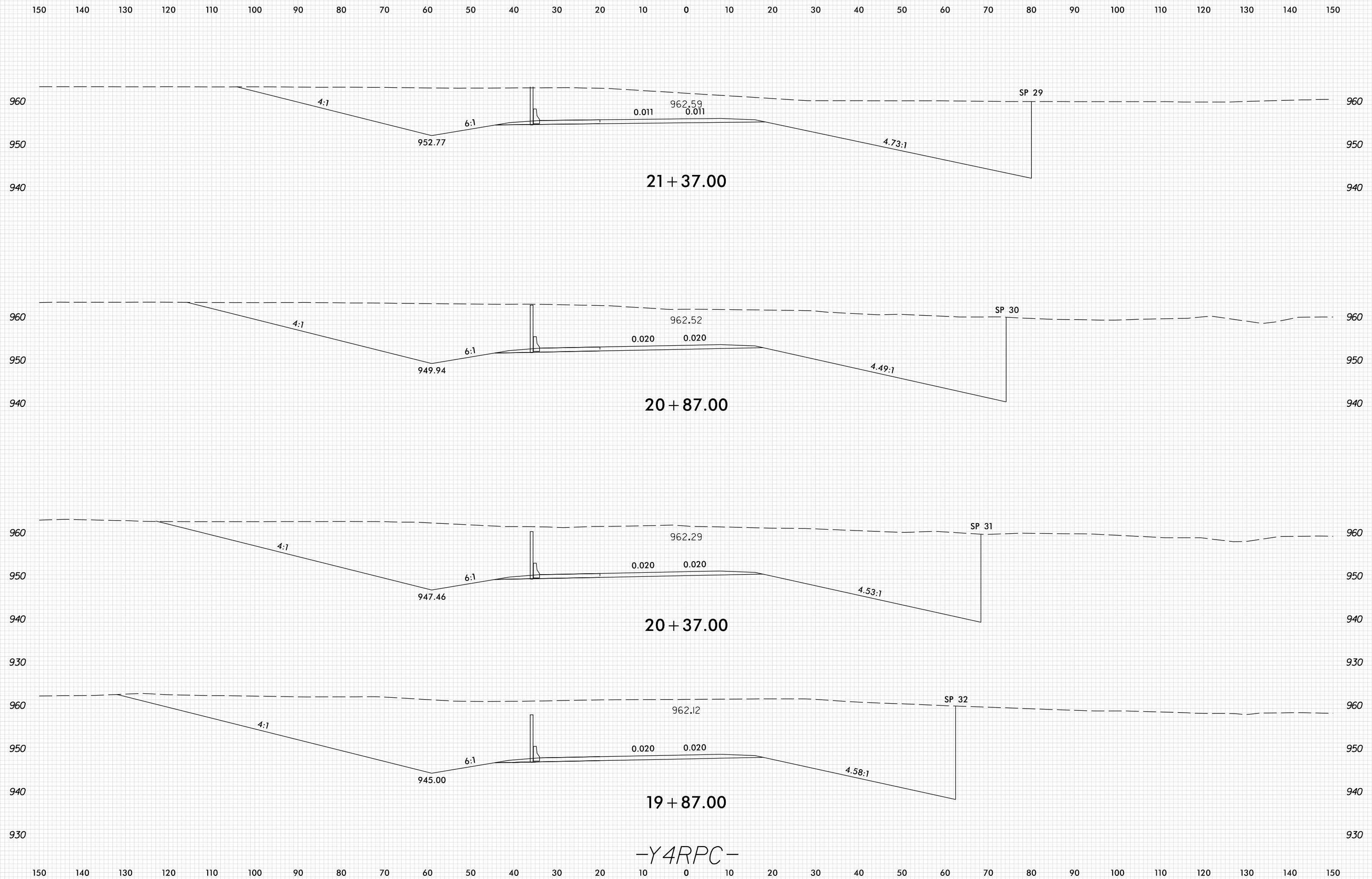

PLOT DRIVER: NCDOT_pdf_color_eng_100.plt
 USER: SPEREIRA
 DATE: 6/10/2021
 TIME: 2:20:20 PM
 FILE: \

8/23/99



PROJ. REFERENCE NO.	SHEET NO.
U-2579AB	X-219

150 140 130 120 110 100 90 80 70 60 50 40 30 20 10 0 10 20 30 40 50 60 70 80 90 100 110 120 130 140 150

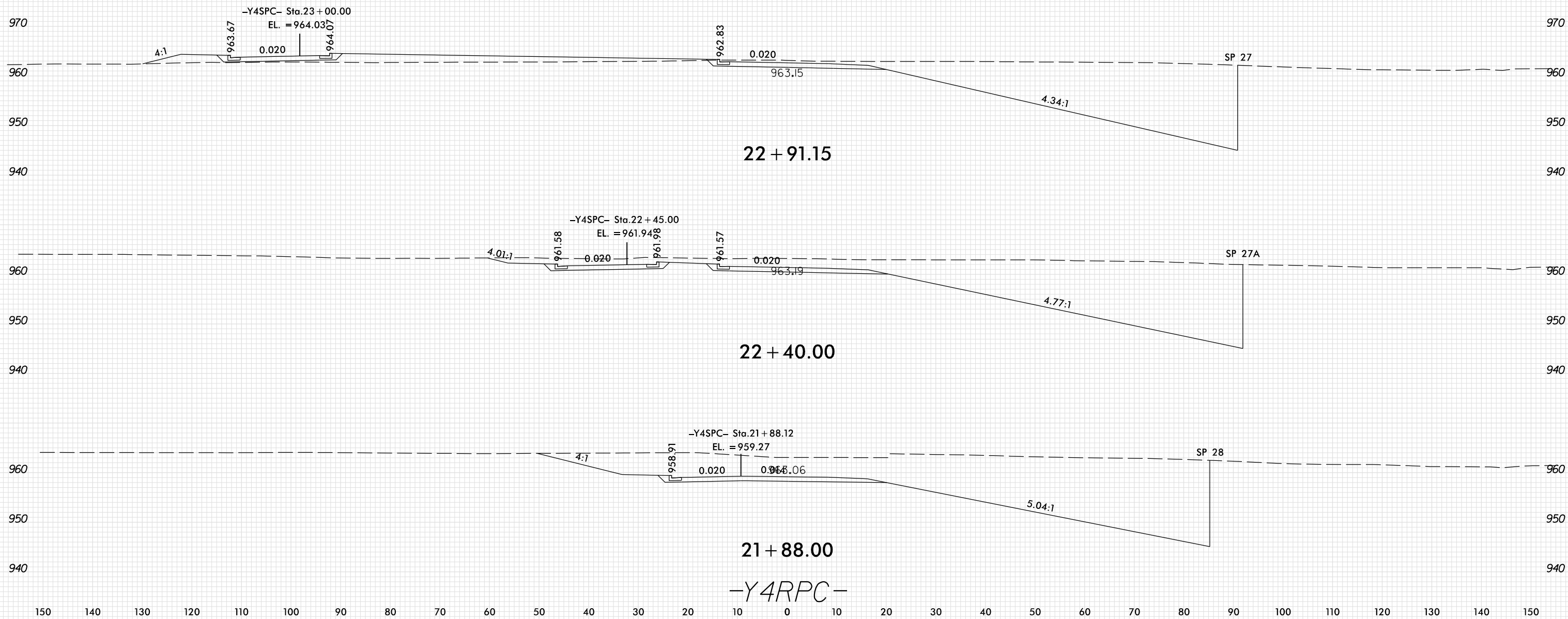

PLOT DRIVER: NCD01_pdf_color_eng_100.plt
 USER: SPEREIRA
 DATE: 6/10/2021
 TIME: 2:20:20 PM
 FILE: \

8/23/99

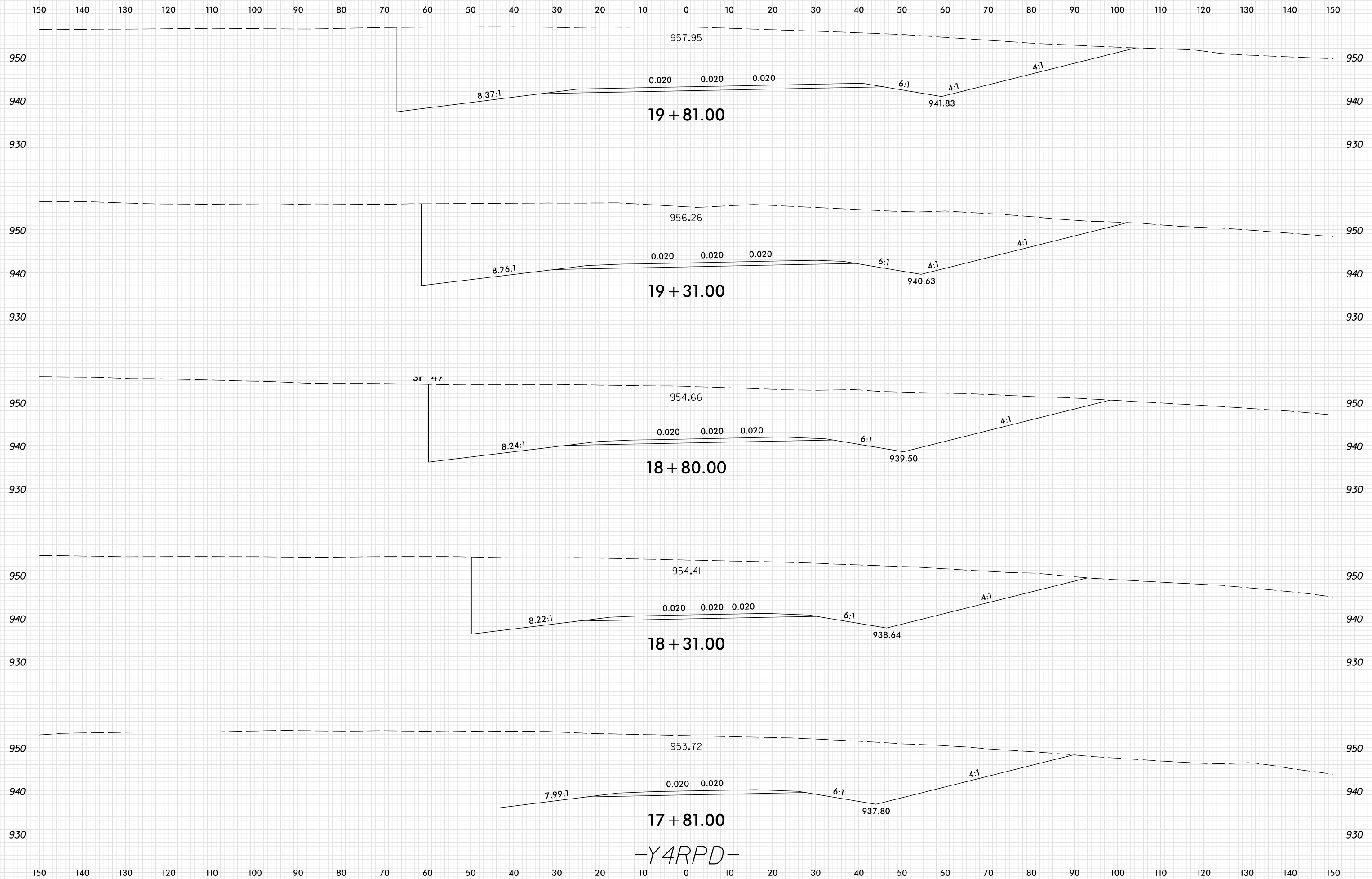

-Y4RPD-

PLOT DRIVER: NCDOT_pdf_color_eng_100.plt
 USER: SPEREIRA
 DATE: 6/10/2021
 TIME: 2:20:29 PM
 FILE: \

8/23/99

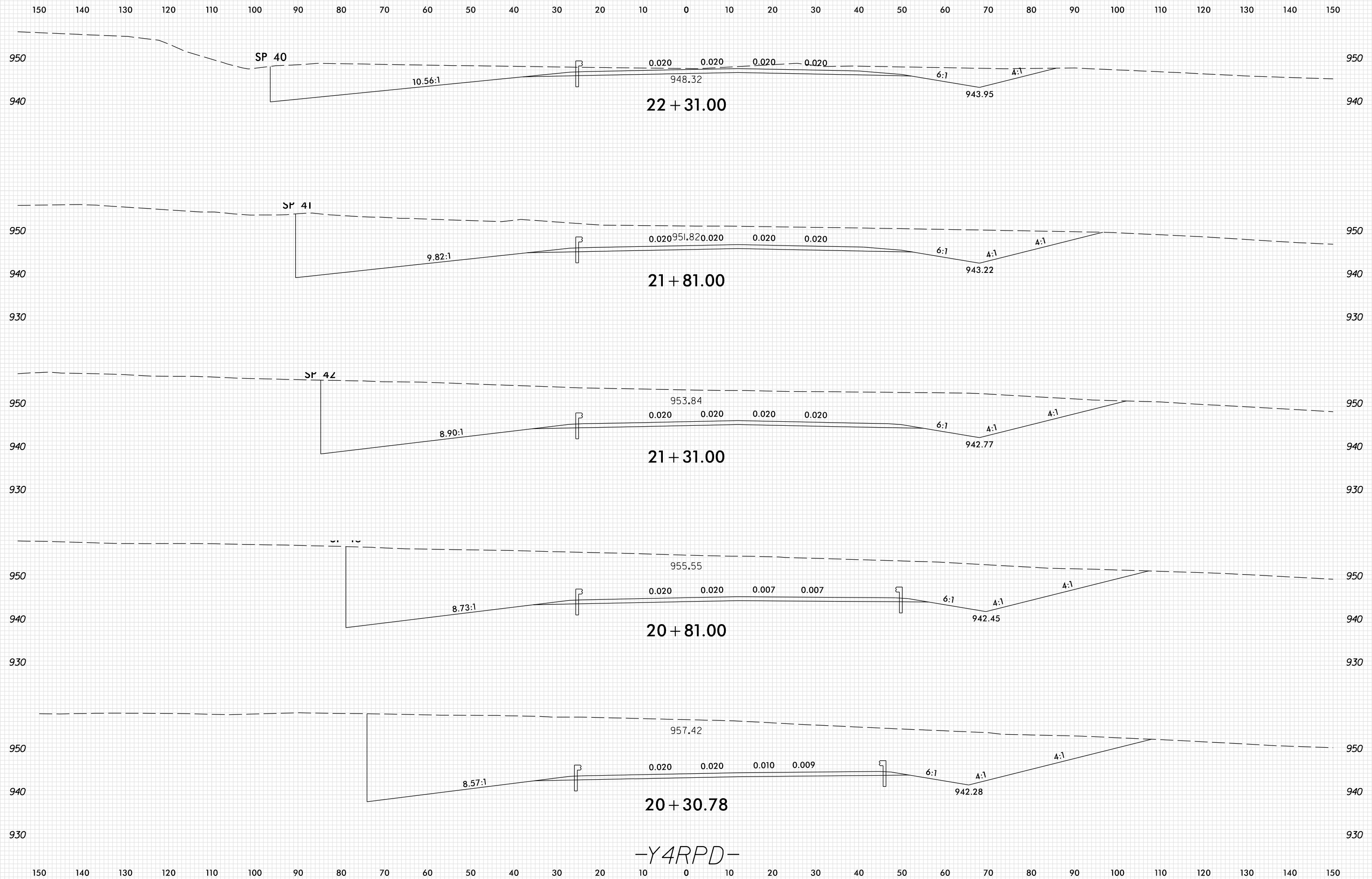

PLOT DRIVER: NCDOT_pdf_color_eng_100.plt
 USER: SPEREIRA
 DATE: 6/10/2021
 TIME: 2:20:30 PM
 FILE: \

-YARD-

8/23/99

0 5 10	PROJ. REFERENCE NO.	SHEET NO.
	U-2579AB	X-222

200 190 180 170 160 150 140 130 120 110 100 90 80 70 60 50 40 30 20 10 0 10 20 30 40 50 60 70 80 90 100

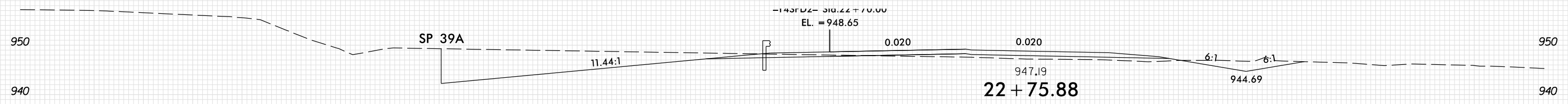
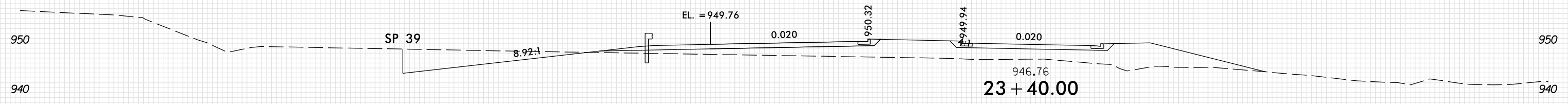
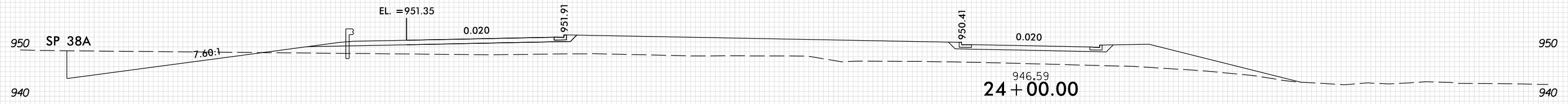

-Y4SPDI-

PLOT DRIVER: NCD01_pdf_color_eng_100.plt
 USER: SPEREIRA
 DATE: 6/10/2021
 TIME: 2:20:37 PM
 FILE: \

8/23/99

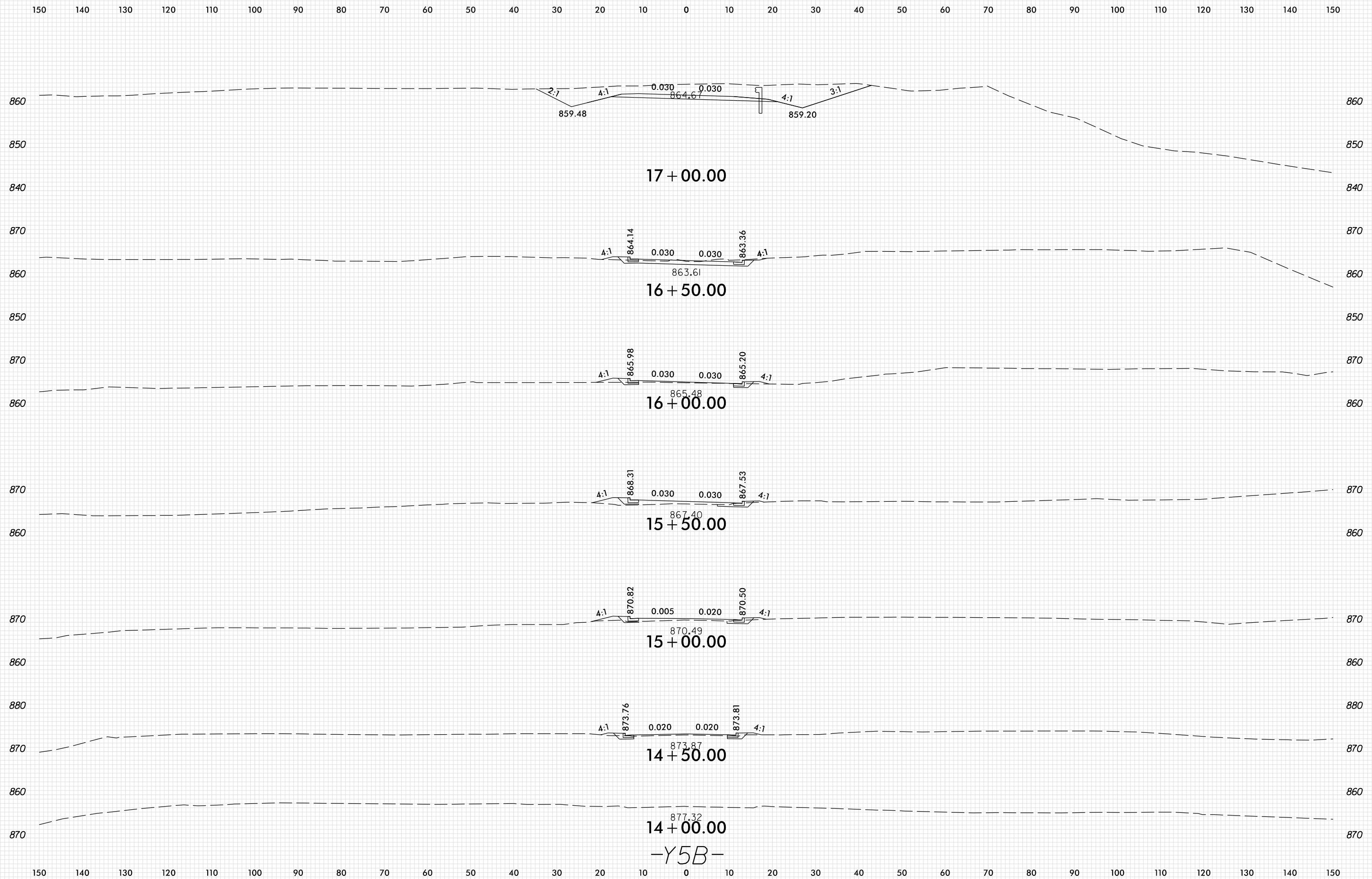

PLOT DRIVER: NCD01_pdf_color_eng_100.plt
 USER: SPEREIRA
 DATE: 6/10/2021
 TIME: 2:20:47 PM
 FILE: \

8/23/99

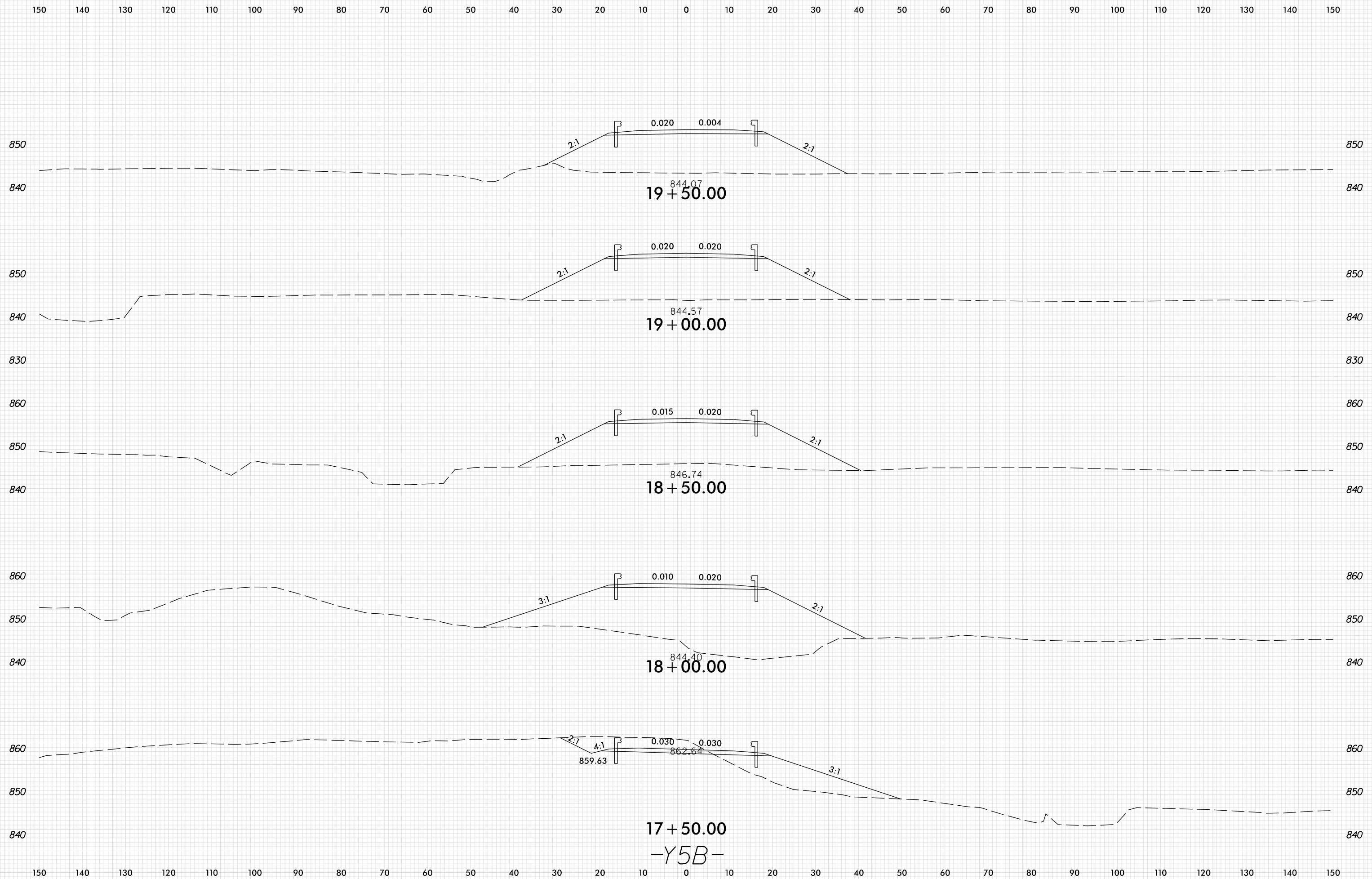

PLOT DRIVER: NCD01_pdf_color_eng_100.plt
 USER: SPEREIRA
 DATE: 6/10/2021
 TIME: 2:20:48 PM
 FILE: \

8/23/99



PROJ. REFERENCE NO.	SHEET NO.
U-2579AB	X-225

150 140 130 120 110 100 90 80 70 60 50 40 30 20 10 0 10 20 30 40 50 60 70 80 90 100 110 120 130 140 150

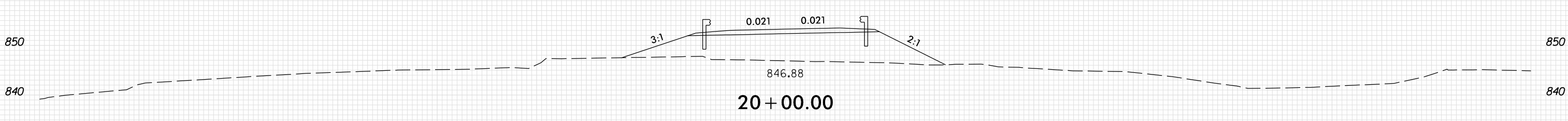
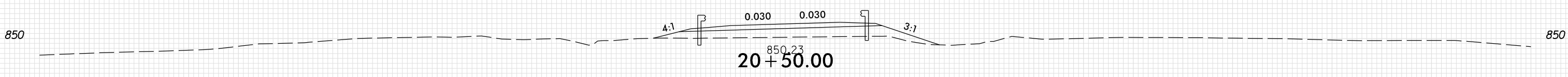
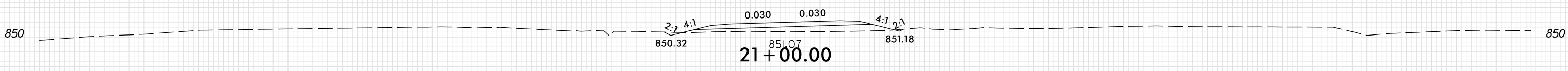
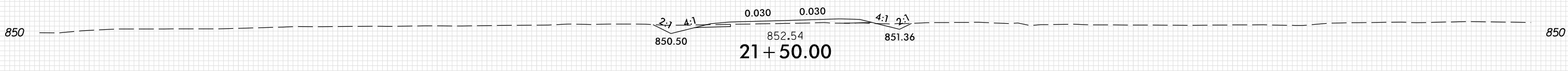
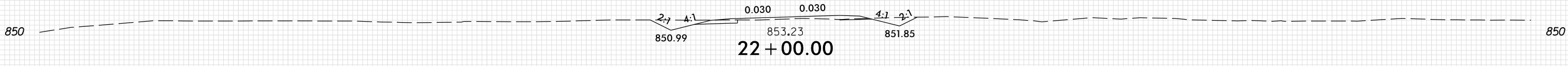
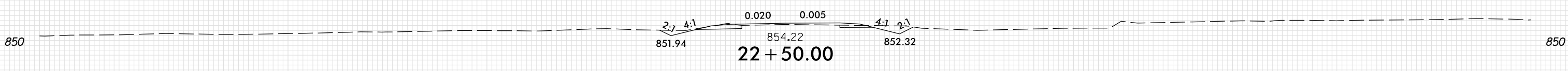
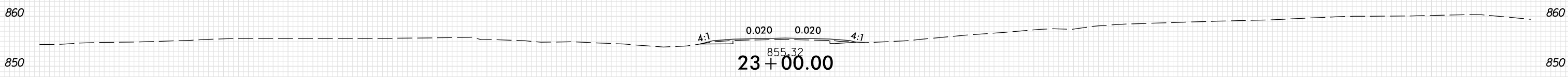
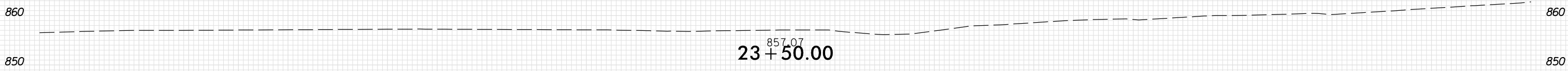

830 840 850 860

-Y5B-

150 140 130 120 110 100 90 80 70 60 50 40 30 20 10 0 10 20 30 40 50 60 70 80 90 100 110 120 130 140 150

PLOT DRIVER: NCDOT_pdf_color_eng_100.plt
USER: SPEREIRA
DATE: 6/10/2021
TIME: 2:20:48 PM
FILE: \

8/23/99

0 5 10	PROJ. REFERENCE NO.	SHEET NO.
	U-2579AB	X-226

150 140 130 120 110 100 90 80 70 60 50 40 30 20 10 0 10 20 30 40 50 60 70 80 90 100 110 120 130 140 150

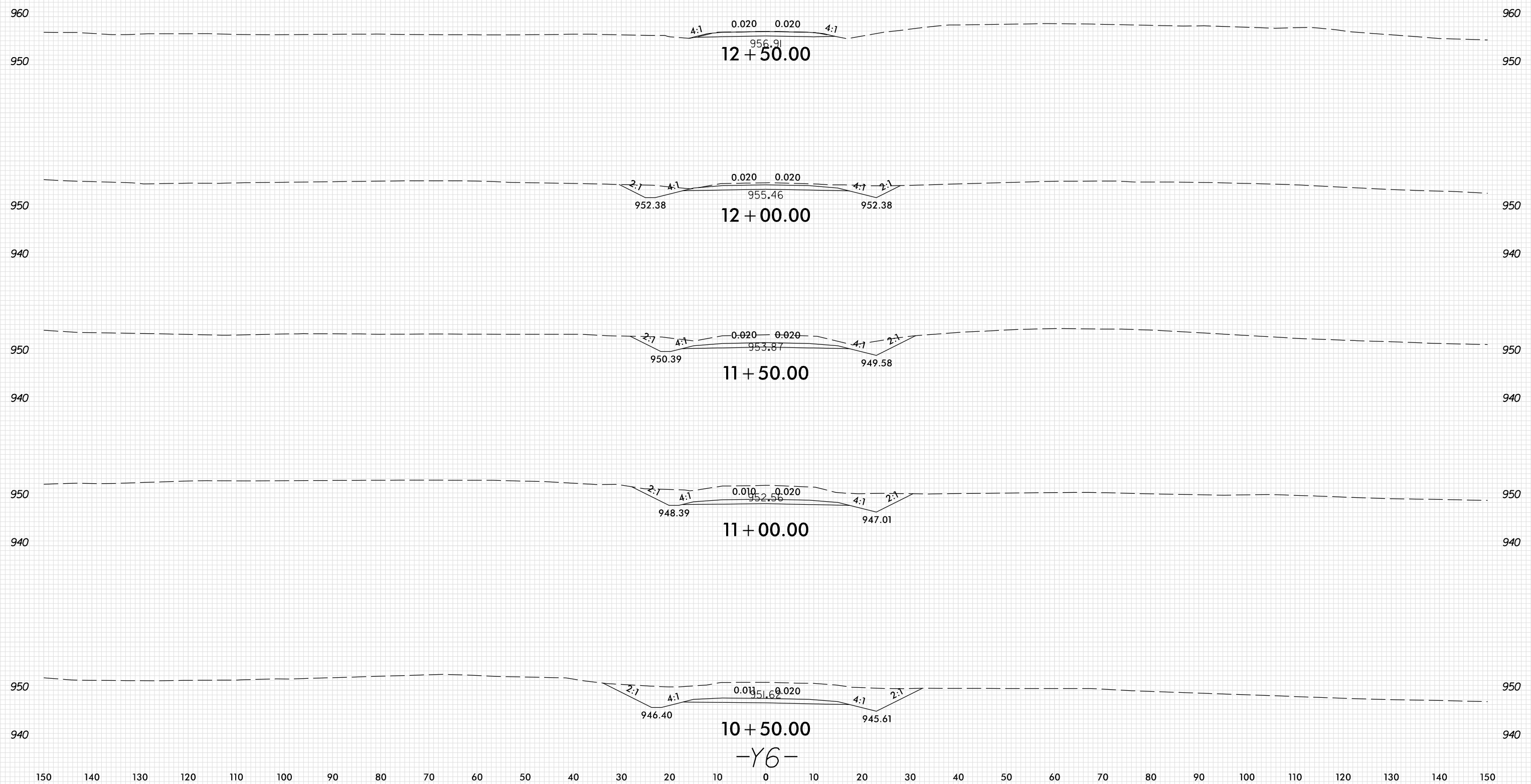

PLOT DRIVER: NCDOT_pdf_color_eng_100.plt
 USER: SPEREIRA
 DATE: 6/10/2021
 TIME: 2:20:55 PM
 FILE: \

150 140 130 120 110 100 90 80 70 60 50 40 30 20 10 0 10 20 30 40 50 60 70 80 90 100 110 120 130 140 150

-Y6-

8/23/99



PROJ. REFERENCE NO.	SHEET NO.
U-2579AB	X-227

150 140 130 120 110 100 90 80 70 60 50 40 30 20 10 0 10 20 30 40 50 60 70 80 90 100 110 120 130 140 150

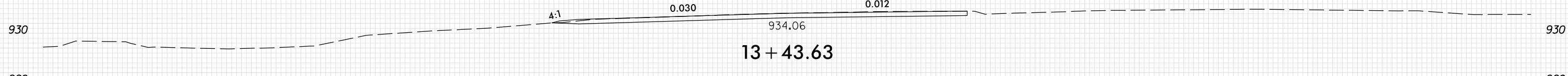
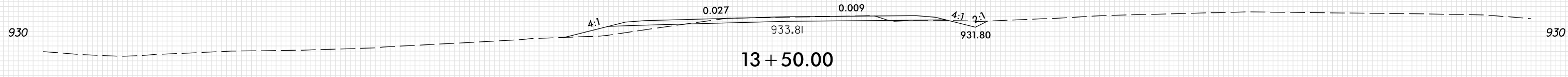
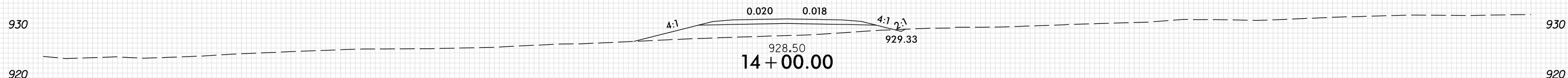
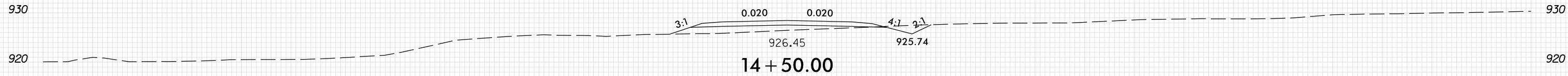

-Y8-

150 140 130 120 110 100 90 80 70 60 50 40 30 20 10 0 10 20 30 40 50 60 70 80 90 100 110 120 130 140 150

PLOT DRIVER: NCDOT_pdf_color_eng_100.plt
 USER: SPEREIRA
 DATE: 8/27/2021
 TIME: 3:24:18 PM
 FILE: \

8/23/99



PROJ. REFERENCE NO.	SHEET NO.
U-2579AB	X-228

150 140 130 120 110 100 90 80 70 60 50 40 30 20 10 0 10 20 30 40 50 60 70 80 90 100 110 120 130 140 150

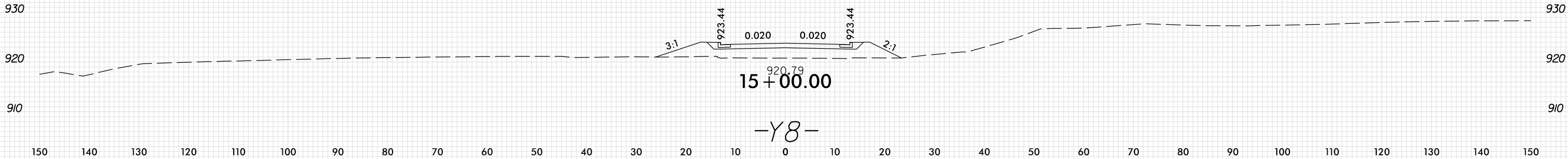
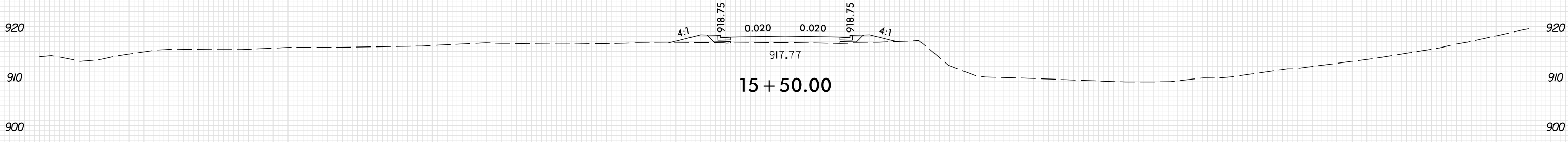
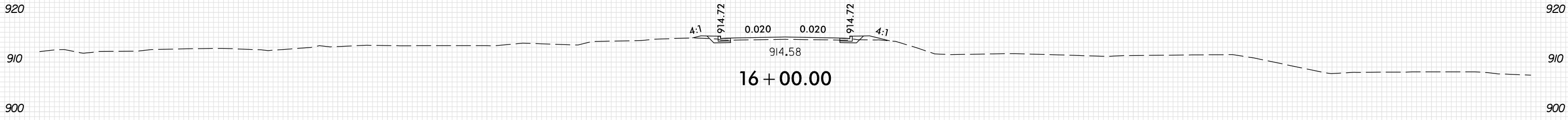
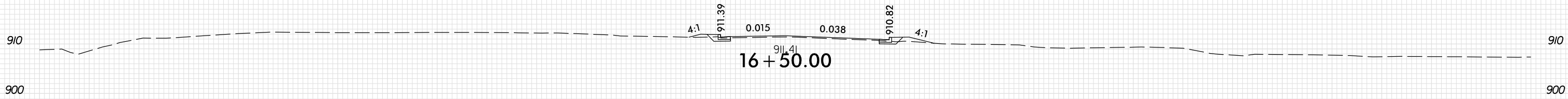

PLOT DRIVER: NCD01_pdf_color_eng_100.plt
 USER: SPEREIRA
 DATE: 8/27/2021
 TIME: 3:24:19 PM
 FILE: \

8/23/99

0 5 10	PROJ. REFERENCE NO.	SHEET NO.
	U-2579AB	X-229

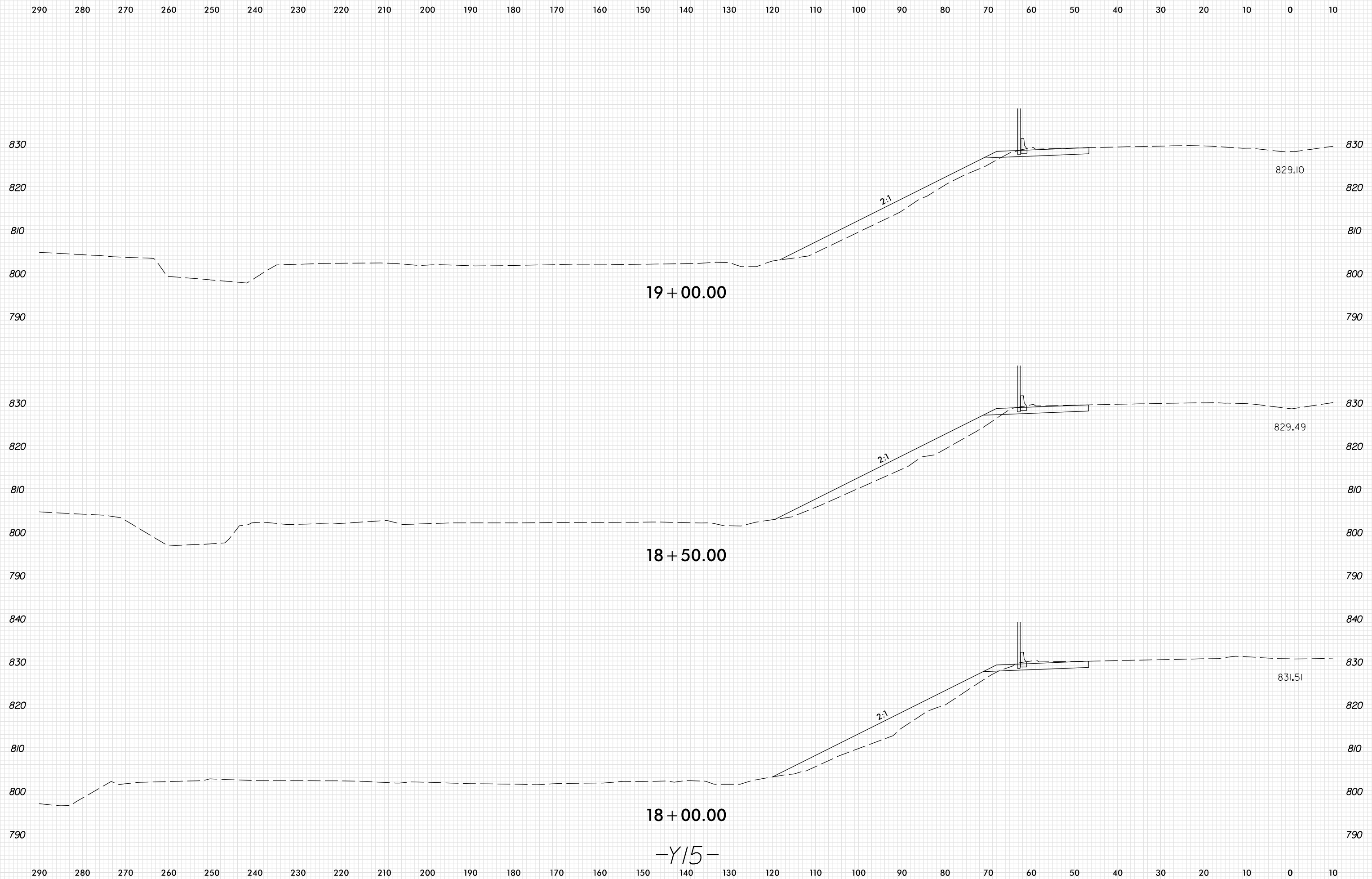

PLOT DRIVER: NCDOT_pdf_color_eng_100.plt
 USER: SPEREIRA
 DATE: 6/10/2021
 TIME: 2:24:22 PM
 FILE: \

-Y15-

8/23/99

	PROJ. REFERENCE NO.	SHEET NO.
	U-2579AB	X-230

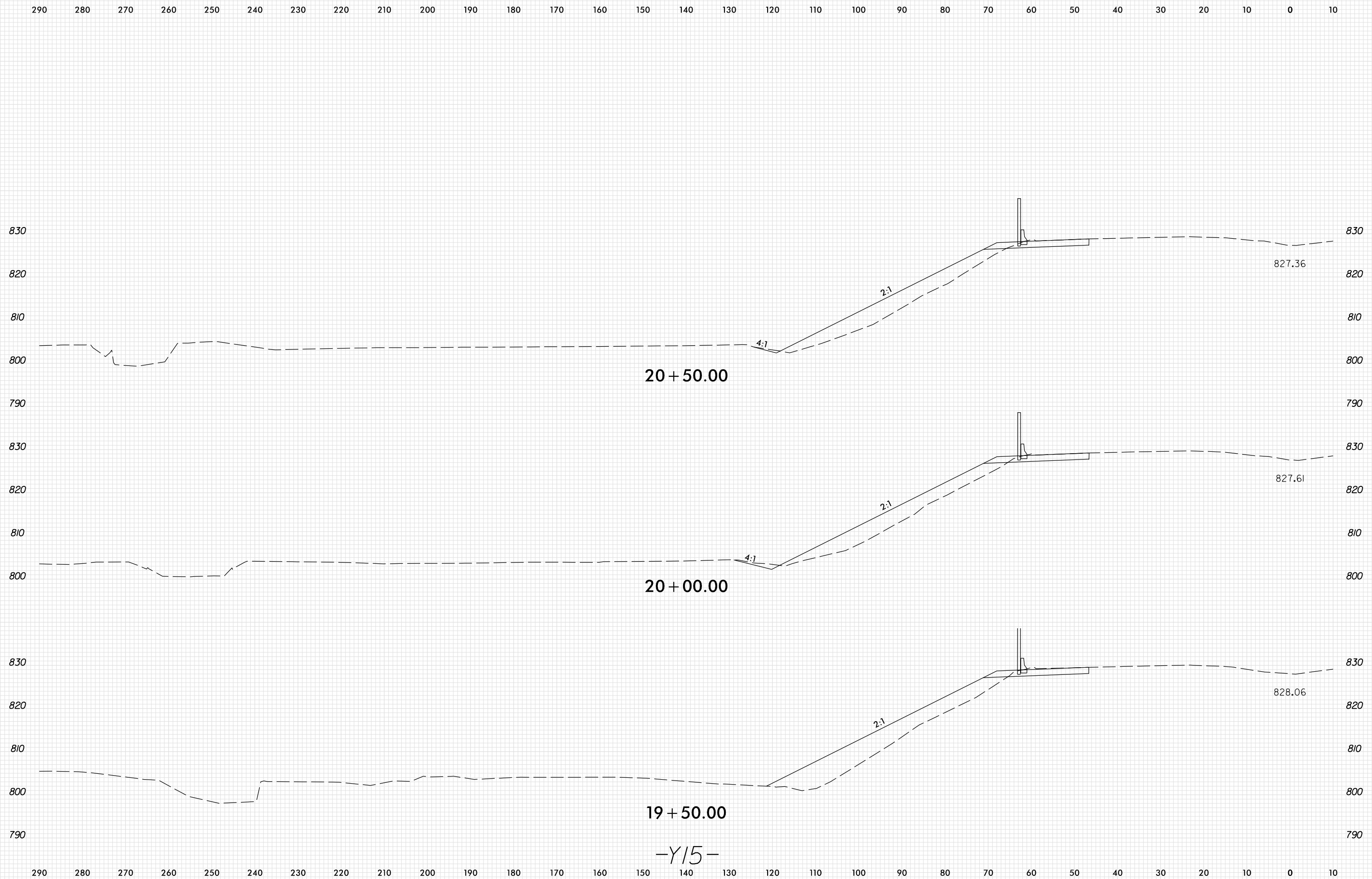

-Y15-

PLOT DRIVER: NCDOT_pdf_color_eng_100.plt
 USER: SPEREIRA
 DATE: 6/10/2021
 TIME: 2:22:22 PM
 FILE: \

8/23/99

0 5 10	PROJ. REFERENCE NO.	SHEET NO.
	U-2579AB	X-231

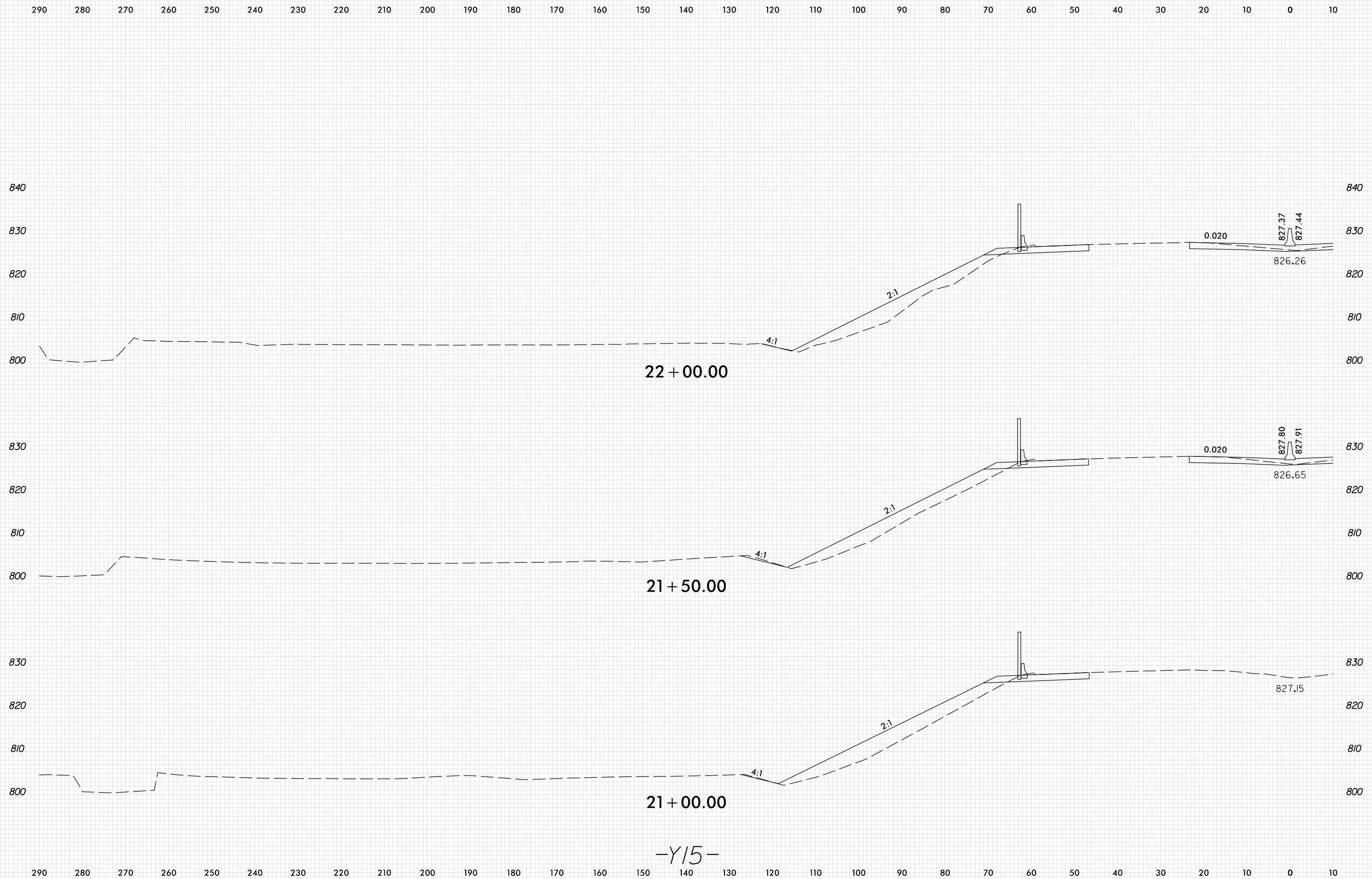

PLOT DRIVER: NCDOT_pdf_color_eng_100.plt
 USER: SPEREIRA
 DATE: 6/10/2021
 TIME: 2:24:23 PM
 FILE: \

-Y15-

8/23/99

0 5 10	PROJ. REFERENCE NO.	SHEET NO.
	U-2579AB	X-232

290 280 270 260 250 240 230 220 210 200 190 180 170 160 150 140 130 120 110 100 90 80 70 60 50 40 30 20 10 0 10

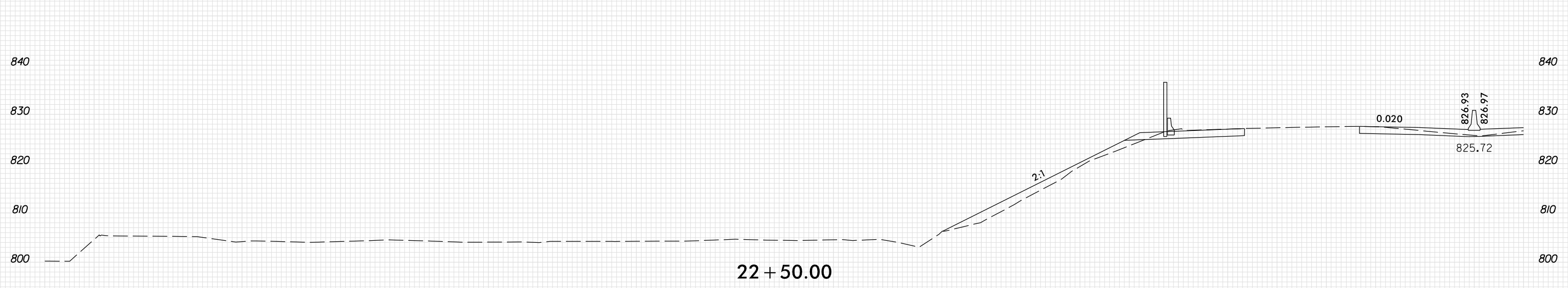
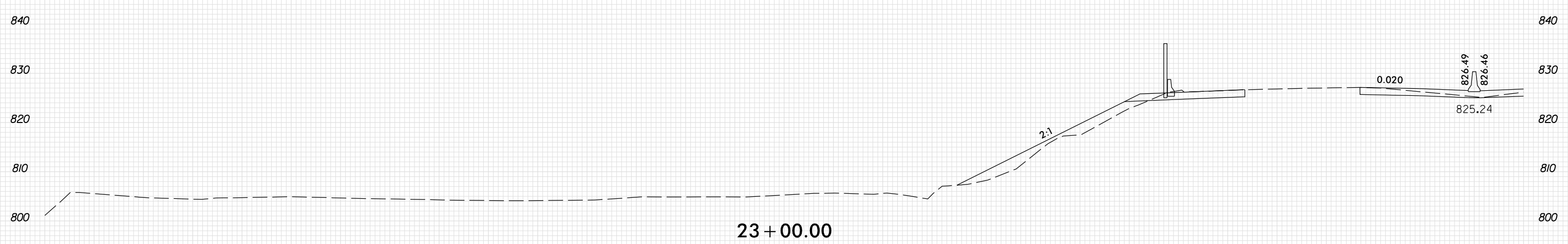
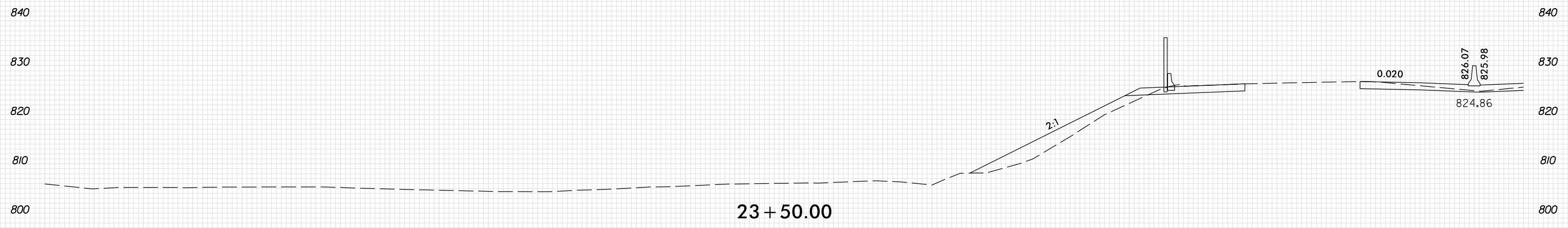

-Y15-

290 280 270 260 250 240 230 220 210 200 190 180 170 160 150 140 130 120 110 100 90 80 70 60 50 40 30 20 10 0 10

PLOT DRIVER: NCDOT_pdf_color_eng_100.plt
 USER: SPEREIRA
 DATE: 6/10/2021
 TIME: 2:24:24 PM
 FILE: \

8/23/99

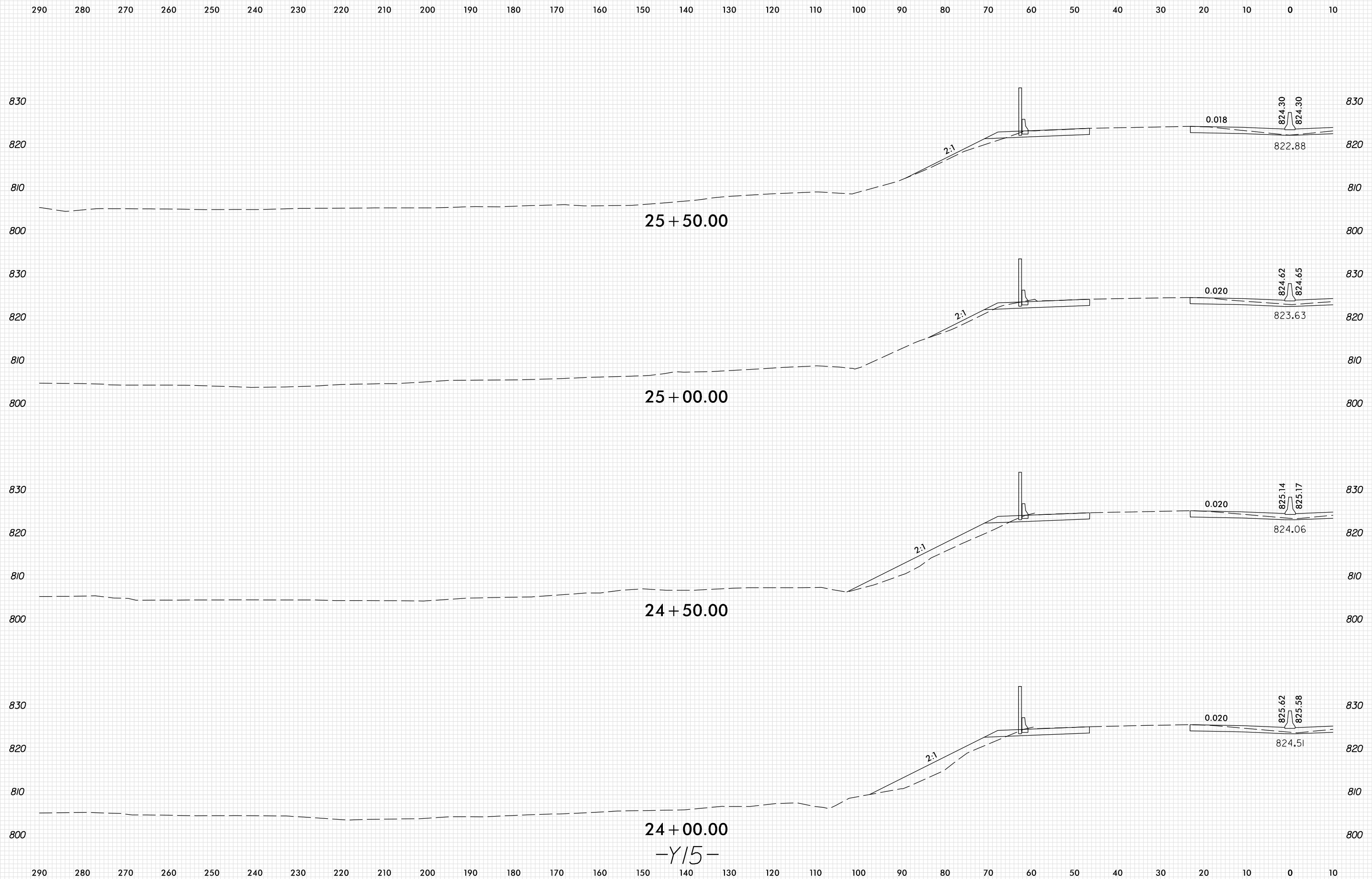

PLOT DRIVER: NCDOT_pdf_color_eng_100.plt
 USER: SPEREIRA
 DATE: 6/10/2021
 TIME: 2:24:24 PM
 FILE: \

24+00.00
 -Y15-

8/23/99

0 5 10	PROJ. REFERENCE NO.	SHEET NO.
	U-2579AB	X-234

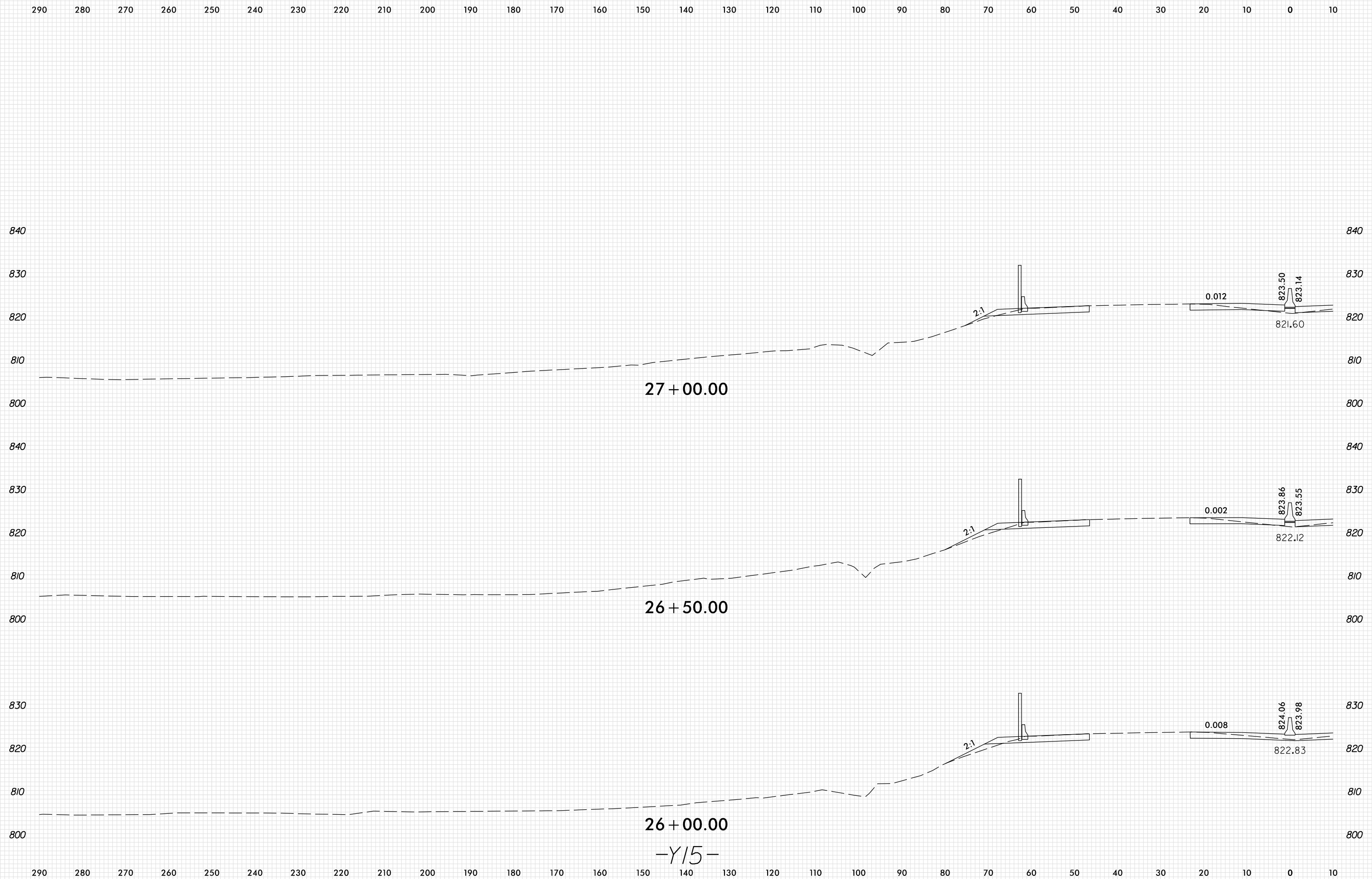

PLOT DRIVER: NCDOT_pdf_color_eng_100.plt
 USER: SPEREIRA
 DATE: 6/10/2021
 TIME: 2:24:25 PM
 FILE: \

-Y15-

8/23/99

0 5 10	PROJ. REFERENCE NO.	SHEET NO.
	U-2579AB	X-235

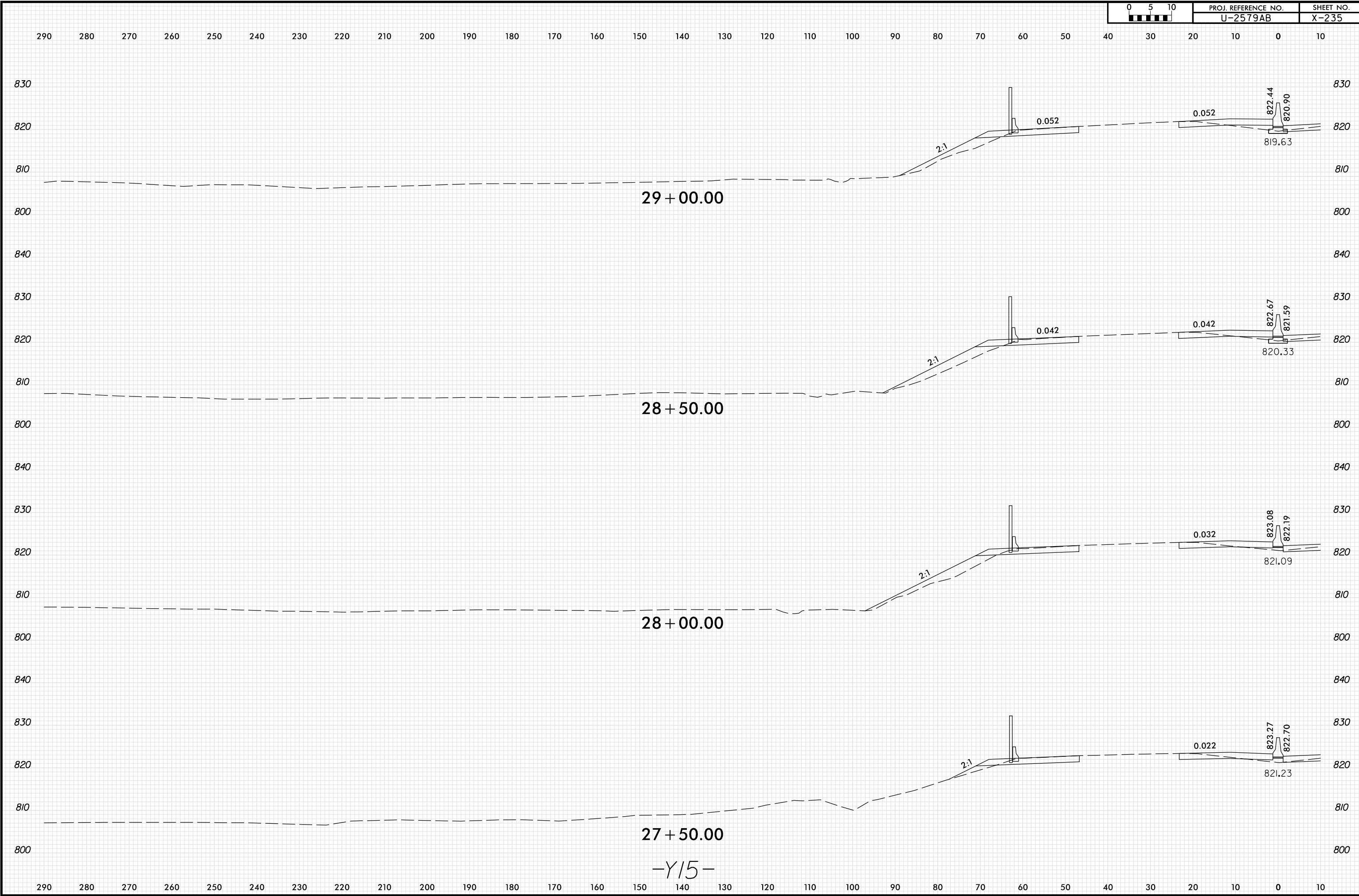

PLOT DRIVER: NCDOT_pdf_color_eng_100.plt
 USER: SPEREIRA
 DATE: 6/10/2021
 TIME: 2:24:26 PM
 FILE: \

-Y15-

8/23/99

0 5 10	PROJ. REFERENCE NO.	SHEET NO.
	U-2579AB	X-236

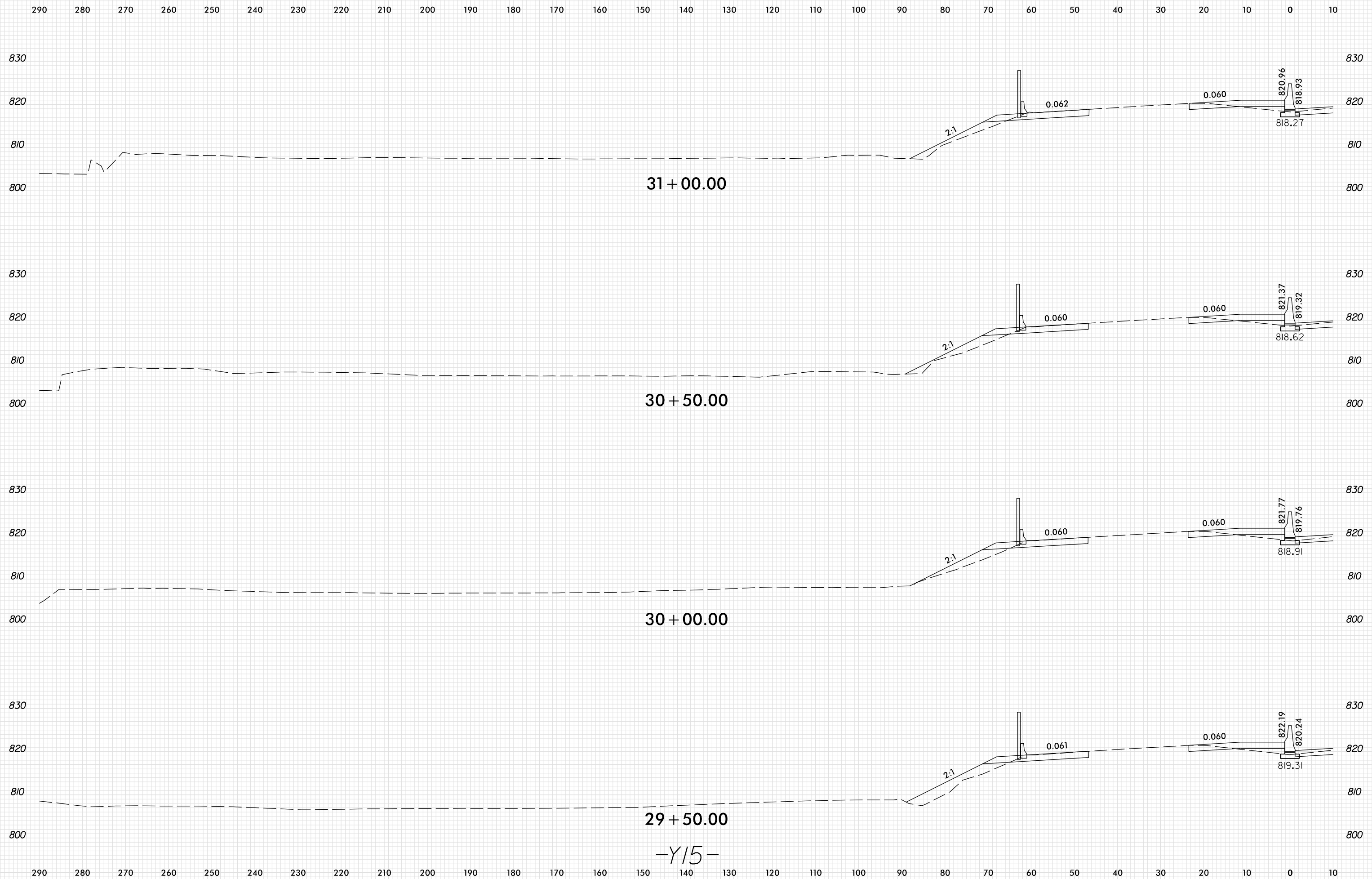

PLOT DRIVER: NCDOT_pdf_color_eng_100.plt
 USER: SPEREIRA
 DATE: 6/10/2021
 TIME: 2:24:26 PM
 FILE: \

-Y15-

8/23/99

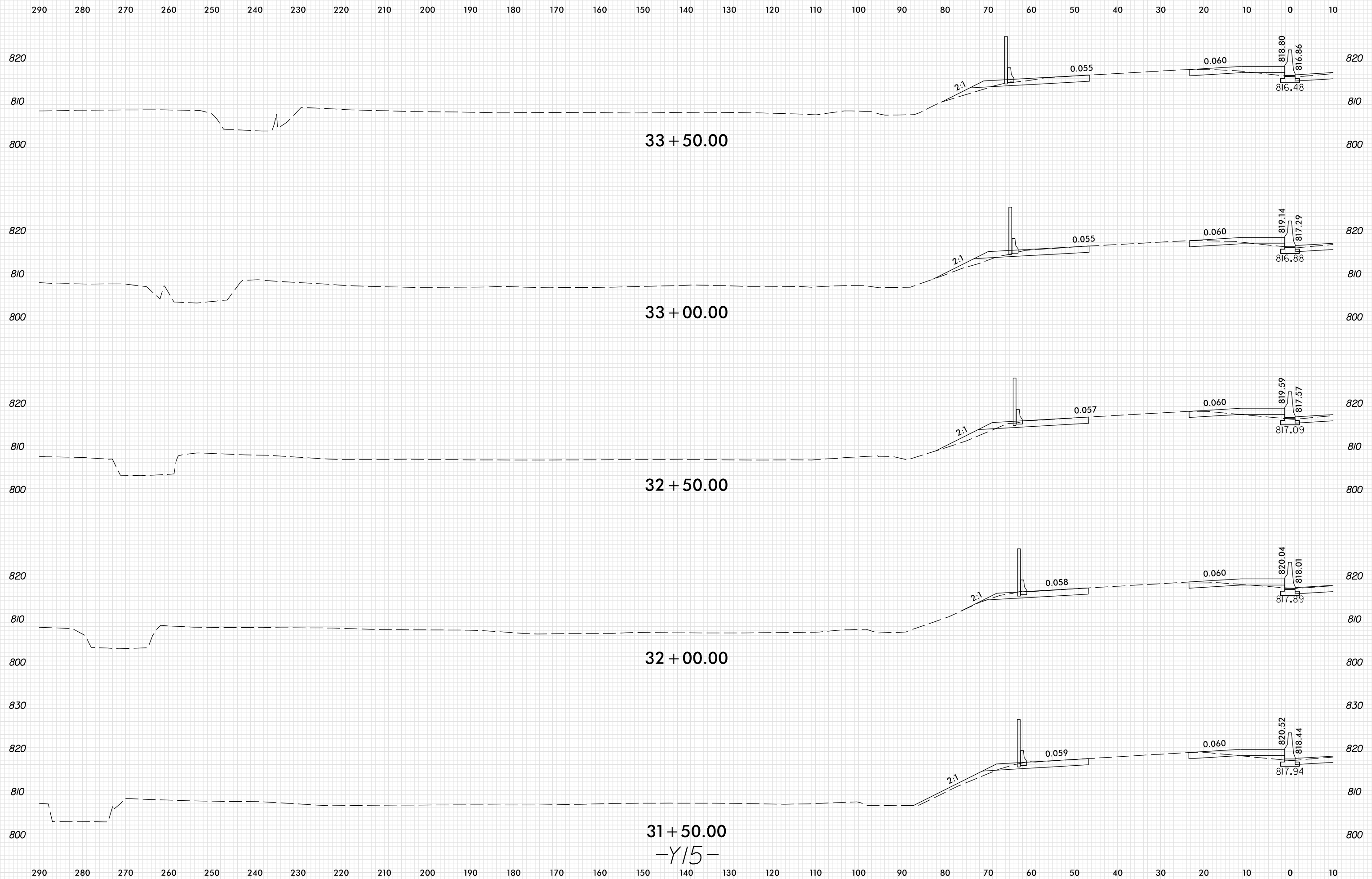

PLOT DRIVER: NCDOT_pdf_color_eng_100.plt
 USER: SPEREIRA
 DATE: 6/10/2021
 TIME: 2:24:27 PM
 FILE: \

31+50.00
 -Y15-

8/23/99

290 280 270 260 250 240 230 220 210 200 190 180 170 160 150 140 130 120 110 100 90 80 70 60 50 40 30 20 10 0 10

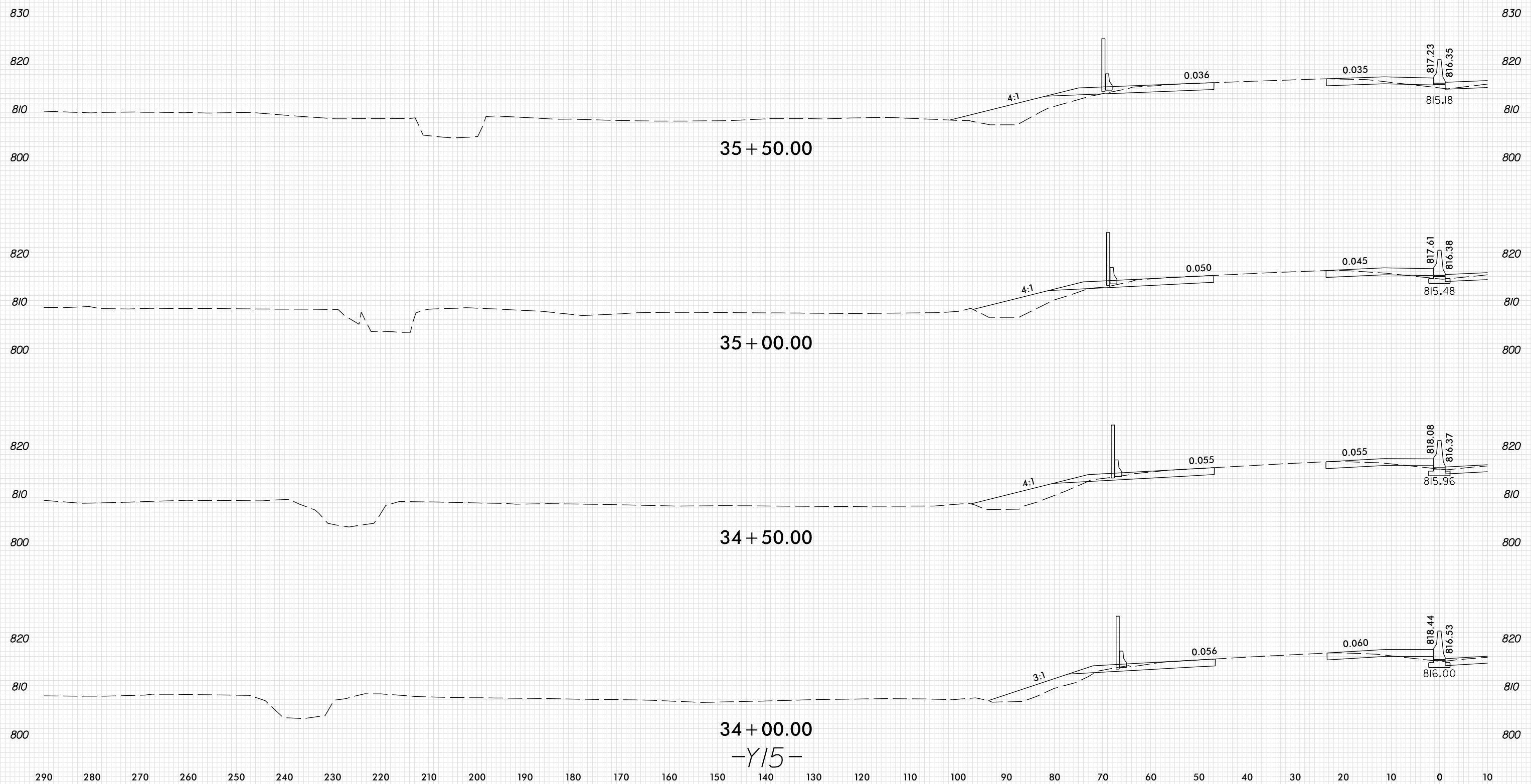

PLOT DRIVER: NCD01_pdf_color_eng_100.plt
 USER: SPEREIRA
 DATE: 6/10/2021
 TIME: 2:24:28 PM
 FILE: \

34+00.00
-Y15-

8/23/99

290 280 270 260 250 240 230 220 210 200 190 180 170 160 150 140 130 120 110 100 90 80 70 60 50 40 30 20 10 0 10

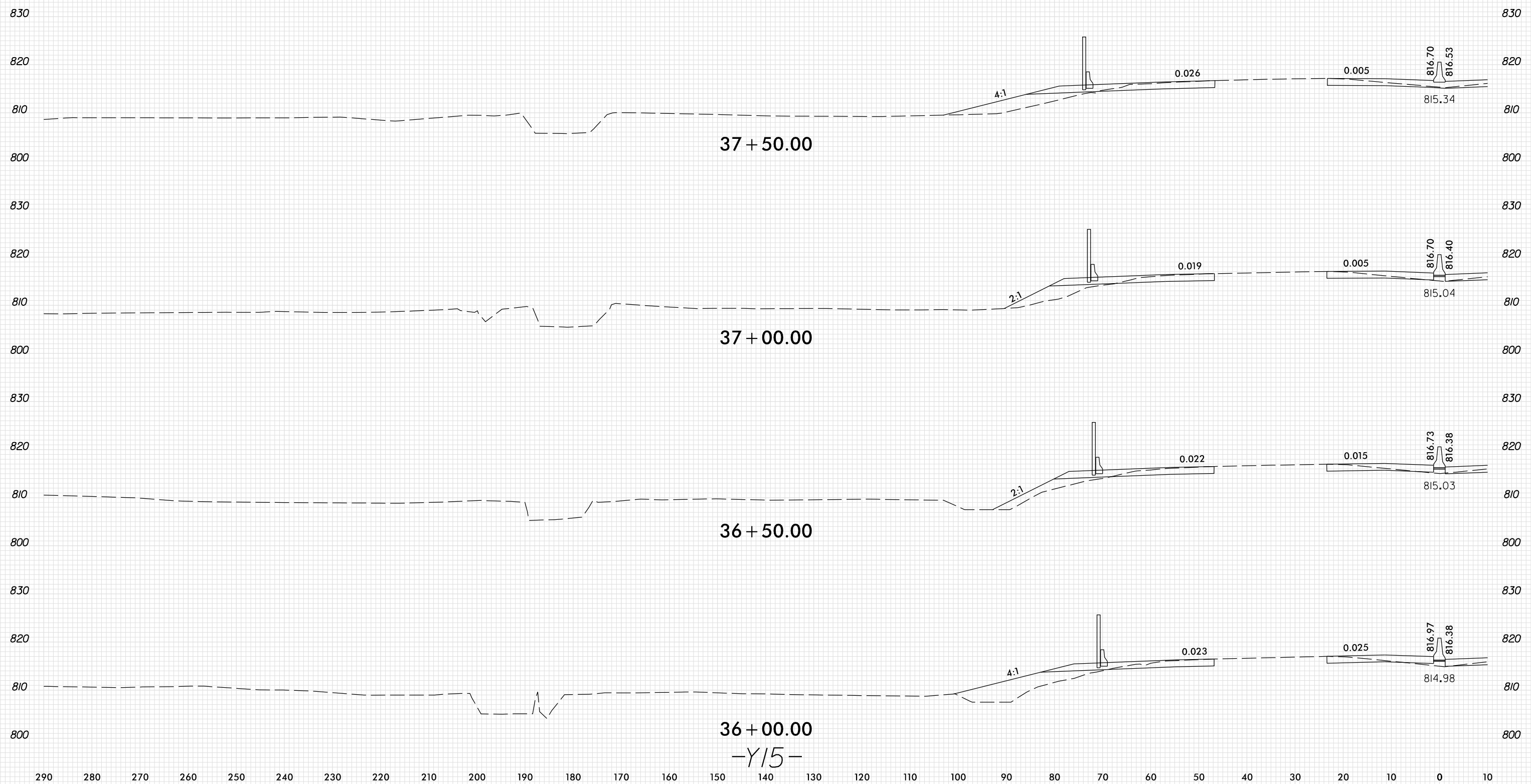

PLOT DRIVER: NCD01_pdf_color_eng_100.plt
 USER: SPEREIRA
 DATE: 6/10/2021
 TIME: 2:24:28 PM
 FILE: \

290 280 270 260 250 240 230 220 210 200 190 180 170 160 150 140 130 120 110 100 90 80 70 60 50 40 30 20 10 0 10

36+00.00
-Y15-

8/23/99

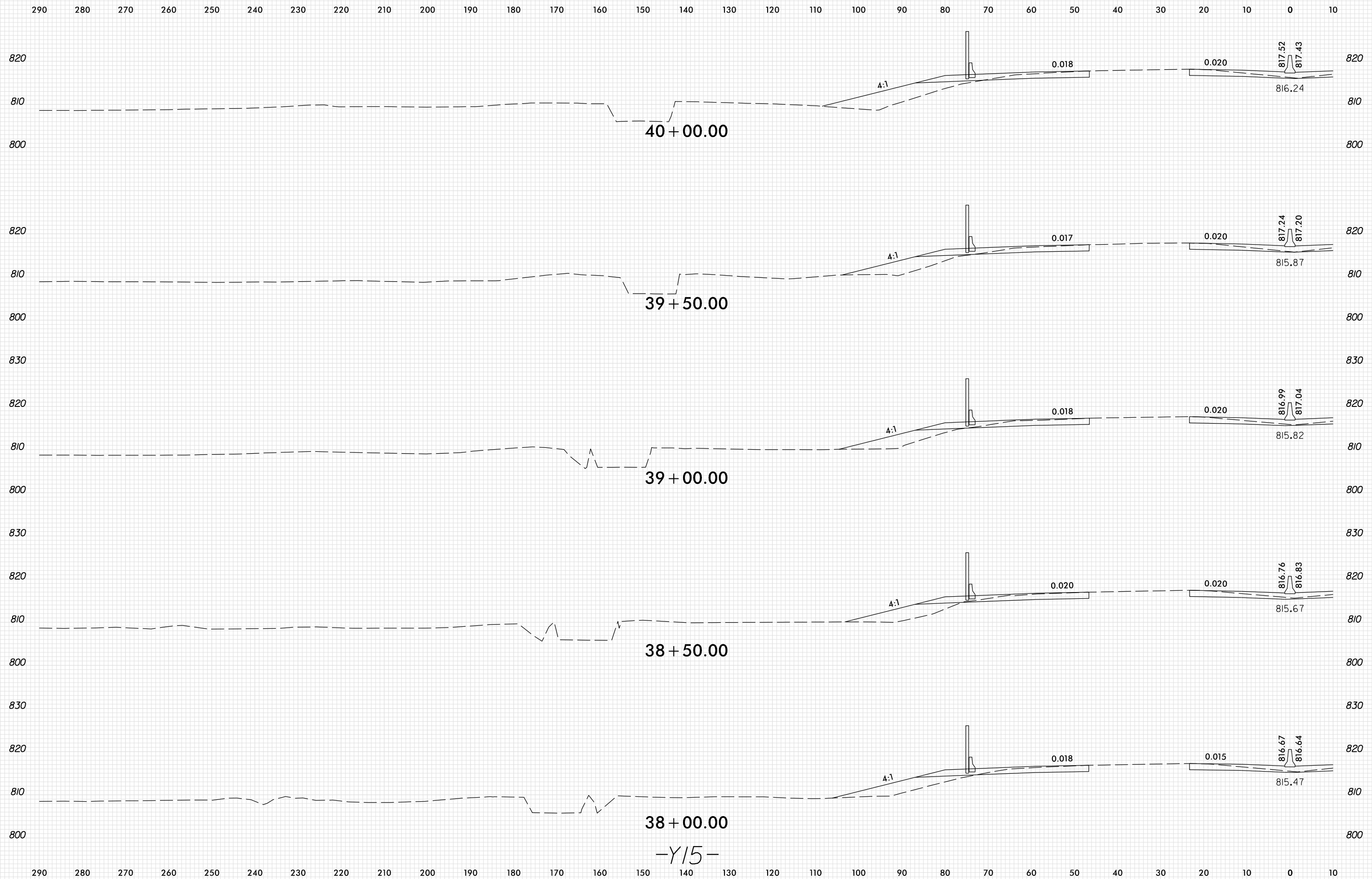

PLOT DRIVER: NCD01_pdf_color_eng_100.plt
 USER: SPEREIRA
 DATE: 6/10/2021
 TIME: 2:24:29 PM
 FILE: \

-Y15-

8/23/99

290 280 270 260 250 240 230 220 210 200 190 180 170 160 150 140 130 120 110 100 90 80 70 60 50 40 30 20 10 0 10

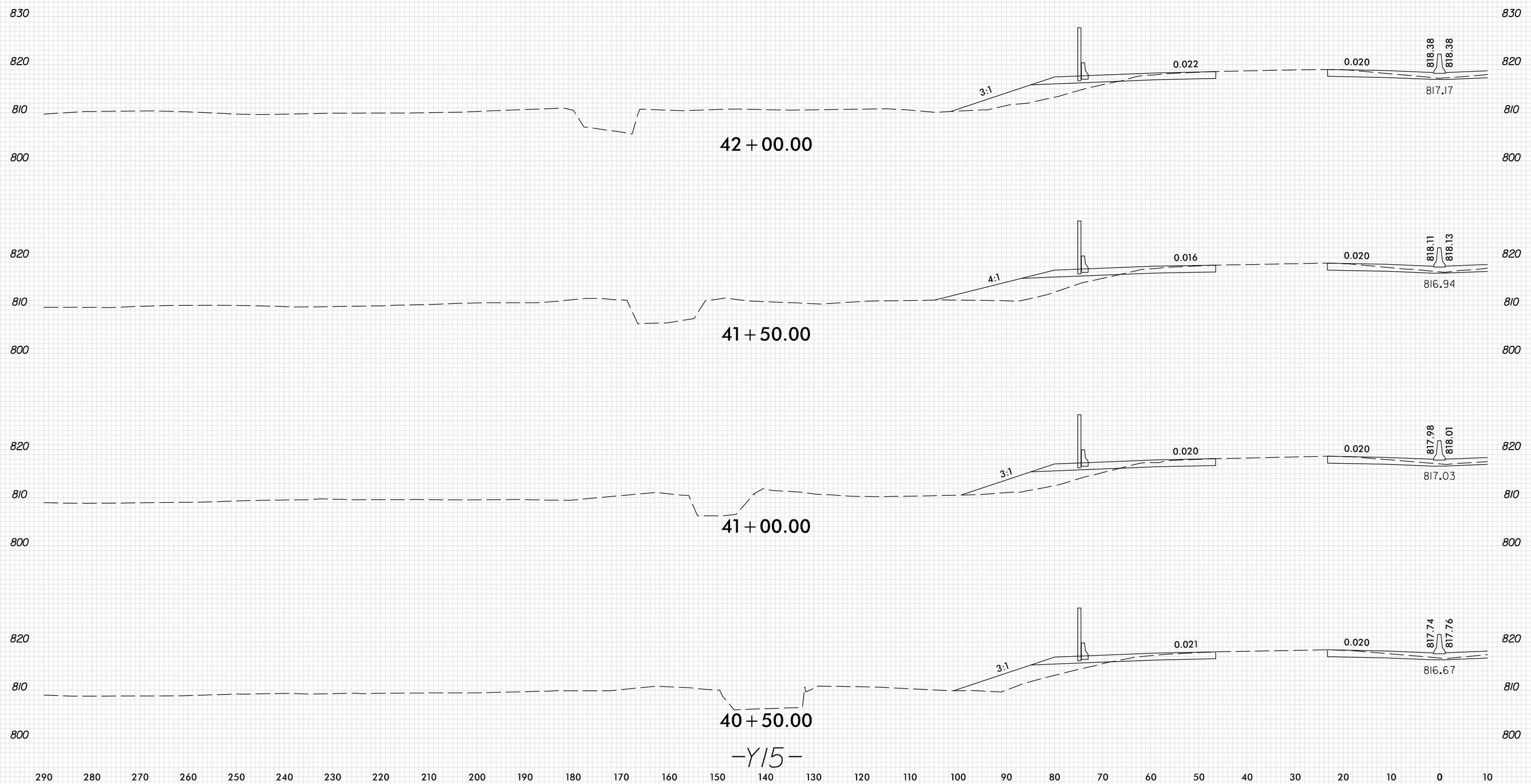

PLOT DRIVER: NCD01_pdf_color_eng_100.plt
USER: SPEREIRA
DATE: 6/10/2021
TIME: 2:24:29 PM
FILE: \

8/23/99

0 5 10	PROJ. REFERENCE NO.	SHEET NO.
	U-2579AB	X-242

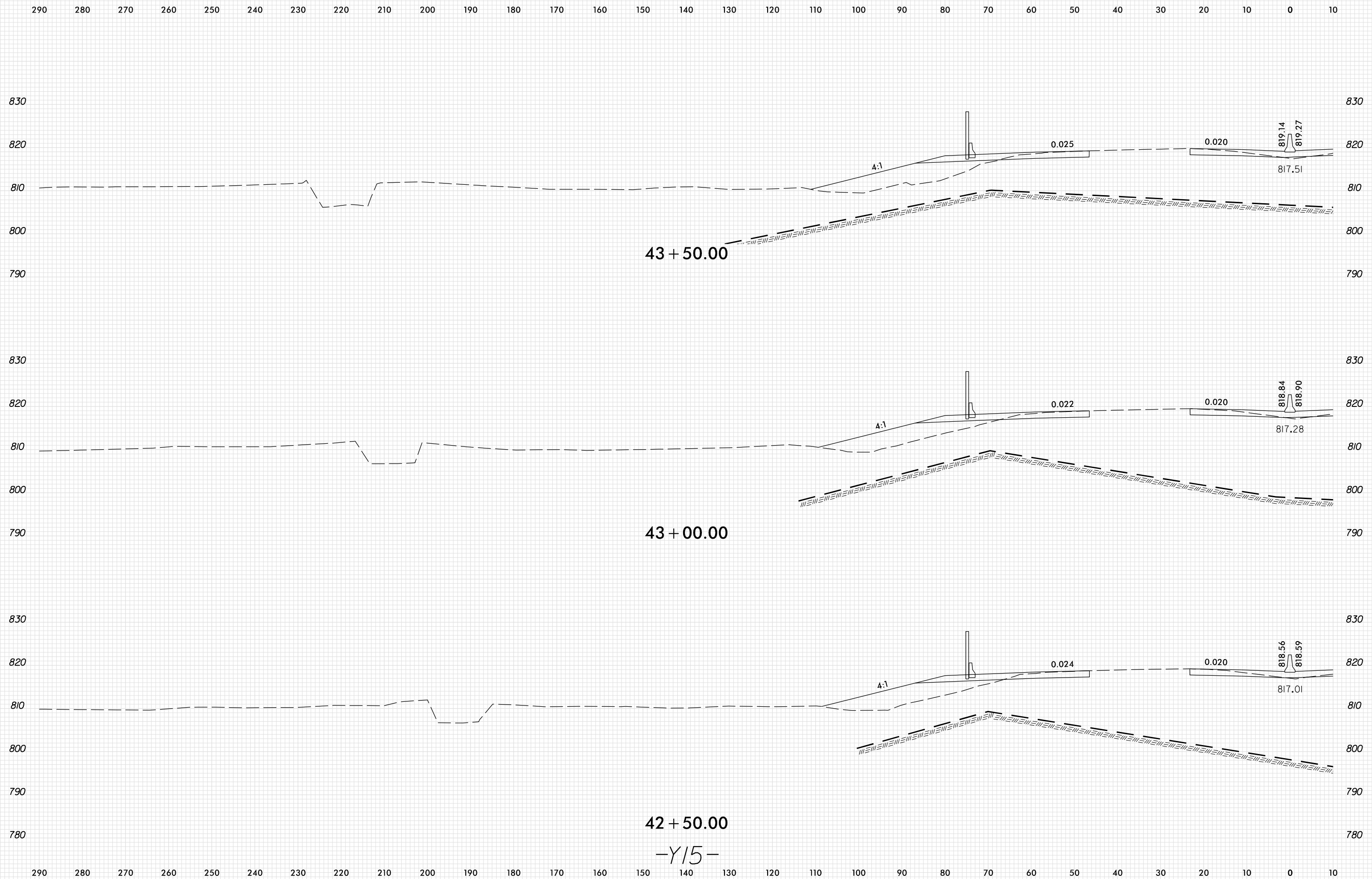

PLOT DRIVER: NCDOT_pdf_color_eng_100.plt
 USER: SPEREIRA
 DATE: 6/10/2021
 TIME: 2:21:30 PM
 FILE: \

42 + 50.00
 -Y15-

8/23/99

0 5 10	PROJ. REFERENCE NO.	SHEET NO.
	U-2579AB	X-243

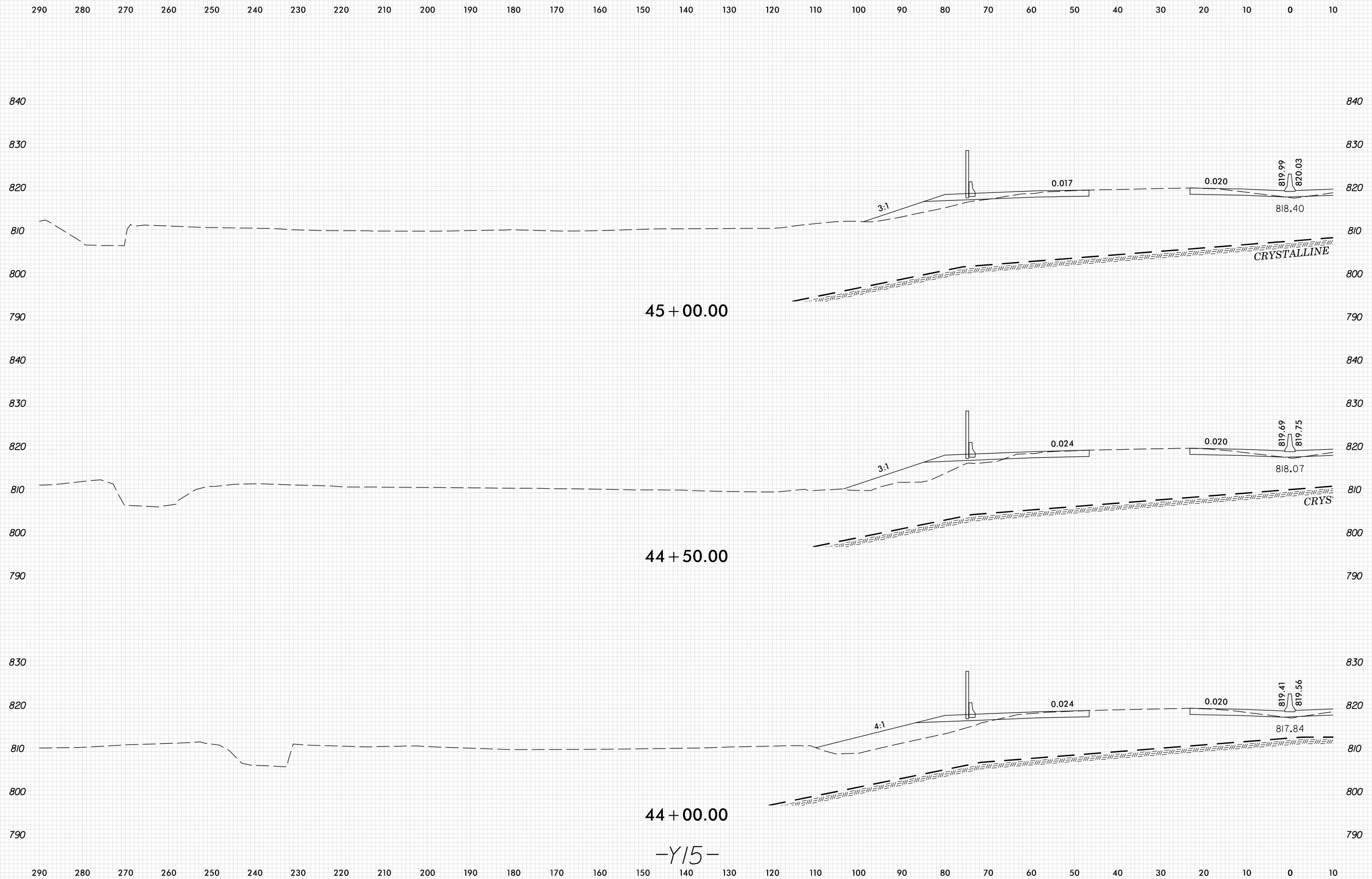

45 + 00.00

44 + 50.00

44 + 00.00

-Y15-

PLOT DRIVER: NCD01_pdf_color_eng_100.plt
 USER: SPEREIRA
 FILE: \

DATE: 6/10/2021
 TIME: 2:21:31 PM

PENTABLE: xpl_en_v8.tbl

8/23/99

0 5 10	PROJ. REFERENCE NO.	SHEET NO.
	U-2579AB	X-244

290 280 270 260 250 240 230 220 210 200 190 180 170 160 150 140 130 120 110 100 90 80 70 60 50 40 30 20 10 0 10

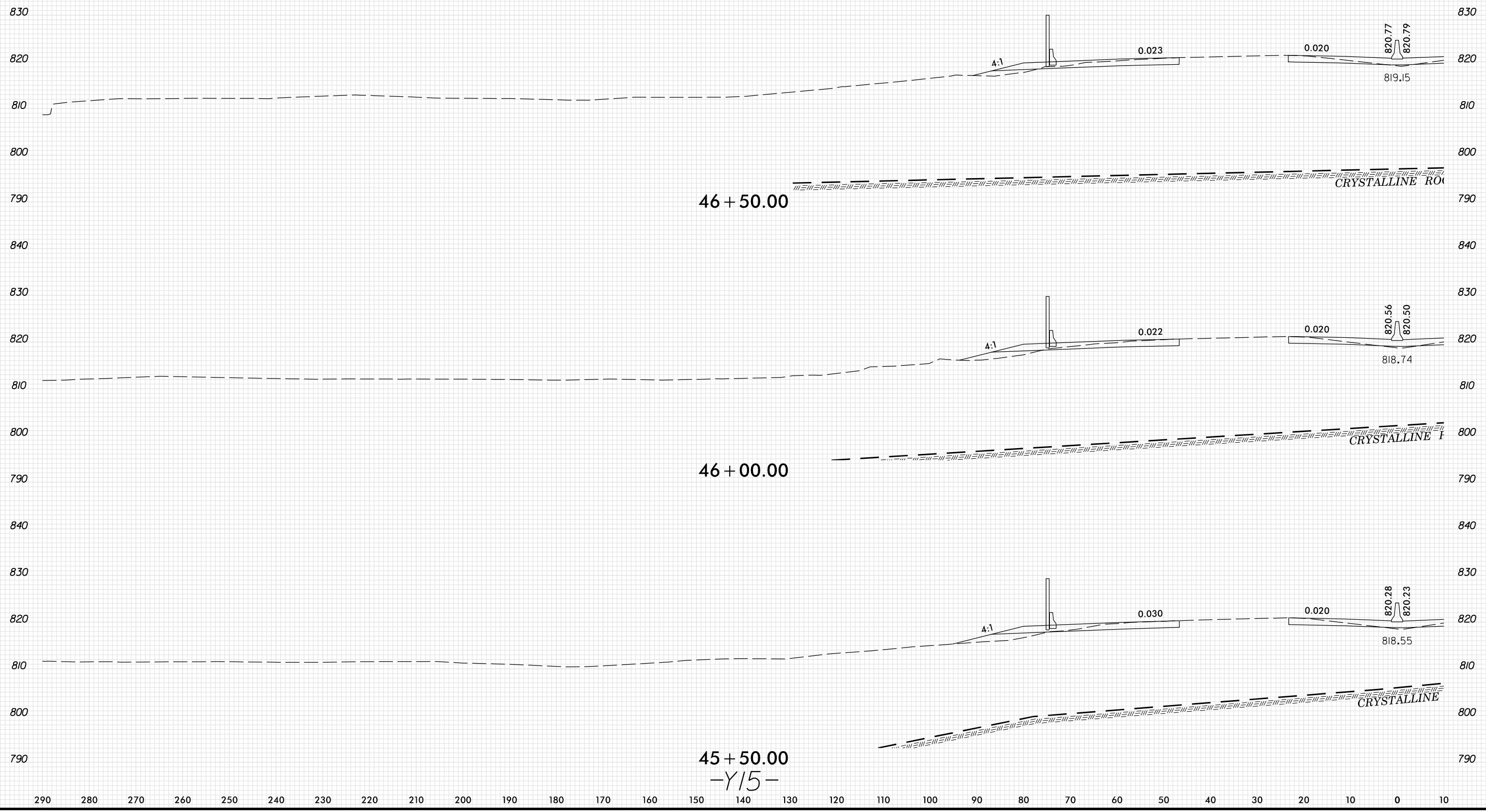

PLOT DRIVER: NCDOT_pdf_color_eng_100.plt
 USER: SPEREIRA
 DATE: 6/10/2021
 TIME: 2:21:32 PM
 FILE: \

8/23/99

0 5 10	PROJ. REFERENCE NO.	SHEET NO.
	U-2579AB	X-245

290 280 270 260 250 240 230 220 210 200 190 180 170 160 150 140 130 120 110 100 90 80 70 60 50 40 30 20 10 0 10

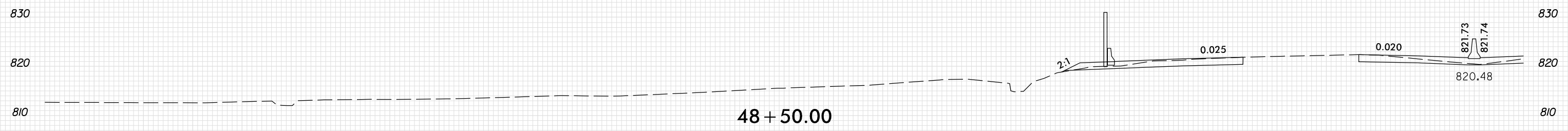

48 + 50.00

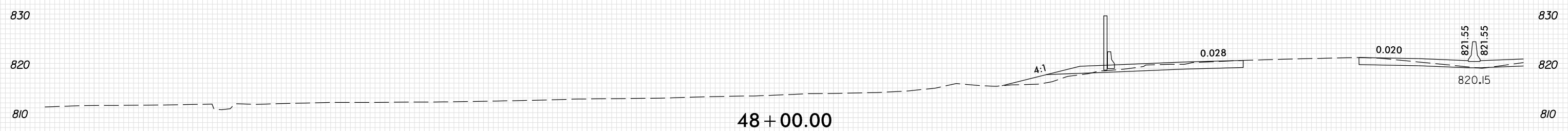

48 + 00.00

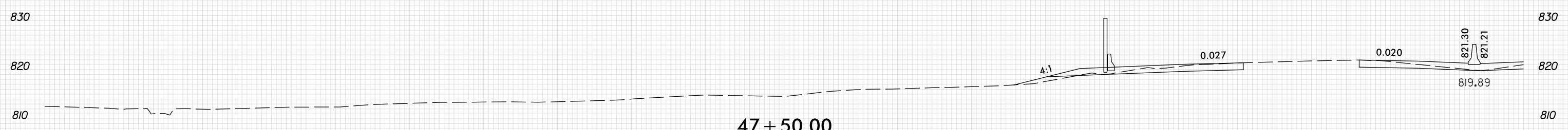

47 + 50.00

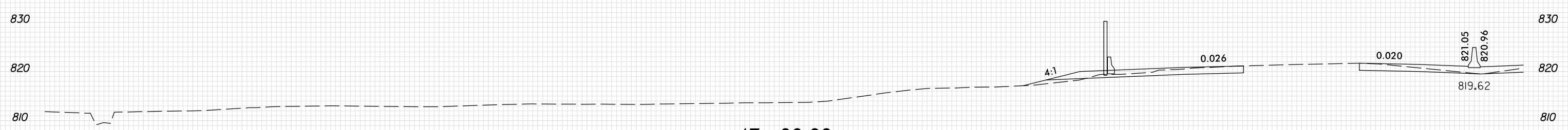

47 + 00.00

-Y15-

290 280 270 260 250 240 230 220 210 200 190 180 170 160 150 140 130 120 110 100 90 80 70 60 50 40 30 20 10 0 10

PLOT DRIVER: NCD01_pdf_color_eng_100.plt
 USER: SPEREIRA
 DATE: 6/10/2021
 TIME: 2:21:32 PM
 FILE: \

8/23/99

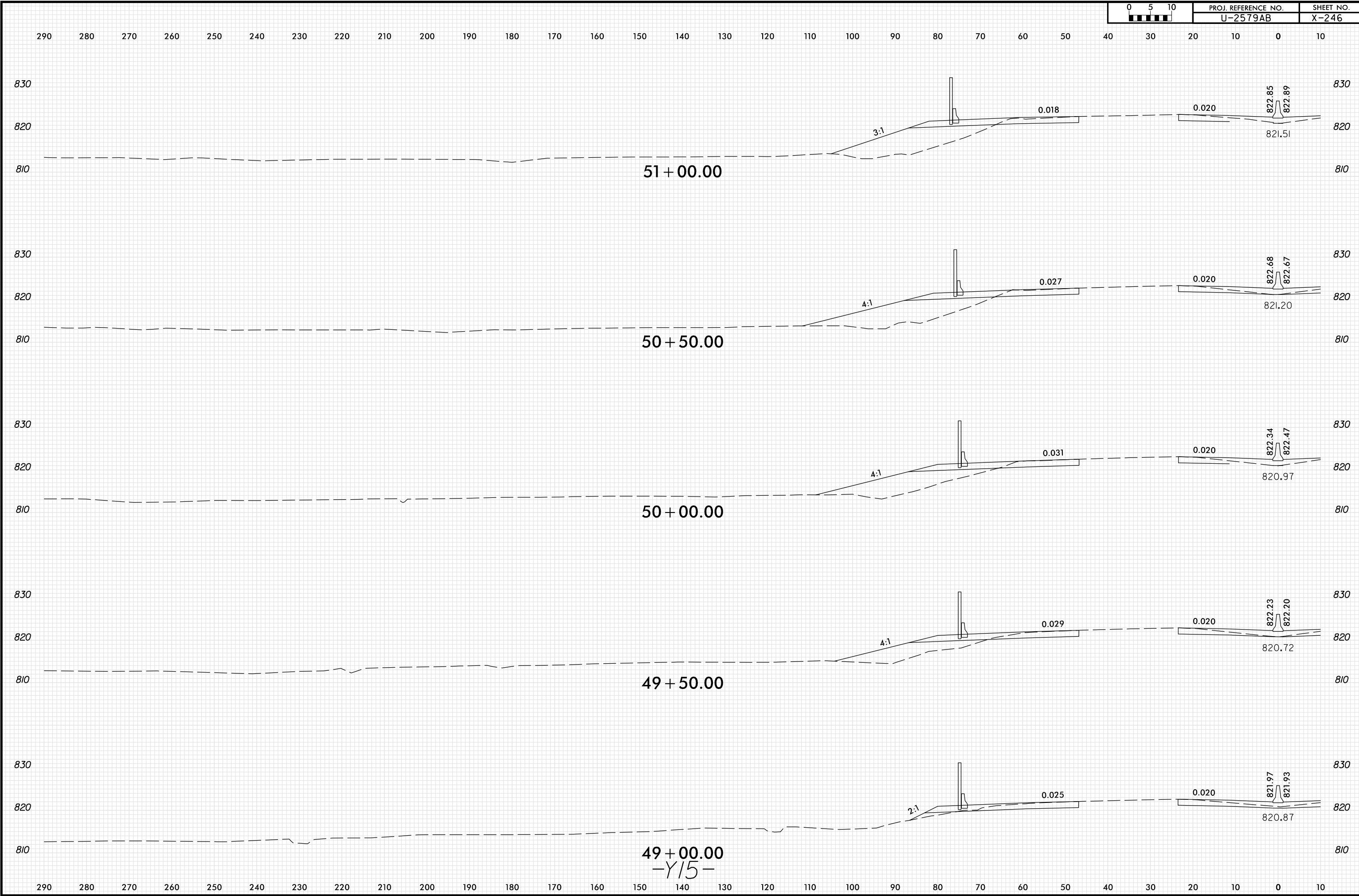

PLOT DRIVER: NCD01.pdf_color_eng_100.plt
 USER: SPEREIRA DATE: 6/10/2021 TIME: 2:21:33 PM
 FILE: \

290 280 270 260 250 240 230 220 210 200 190 180 170 160 150 140 130 120 110 100 90 80 70 60 50 40 30 20 10 0 10

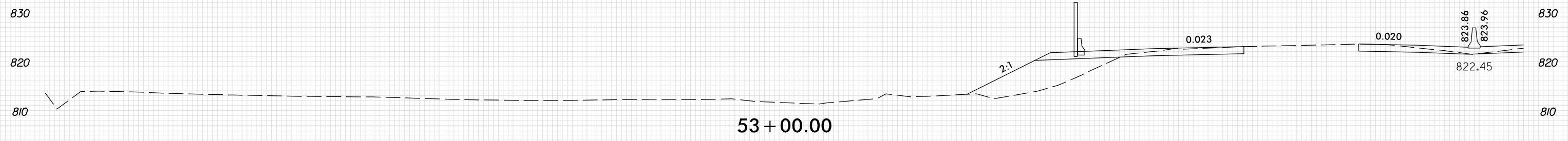

53 + 00.00

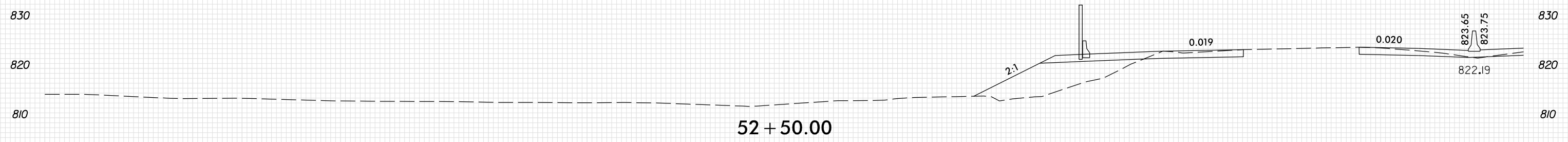

52 + 50.00

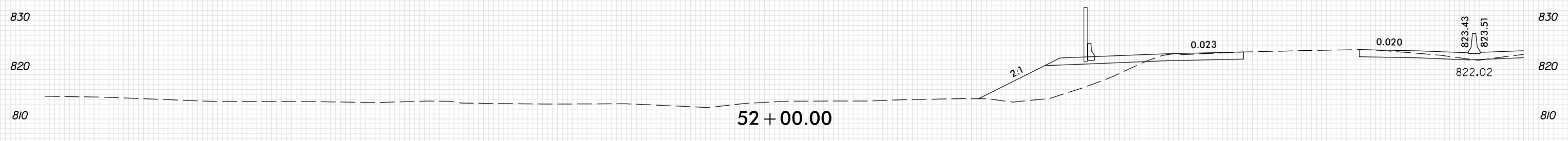

52 + 00.00

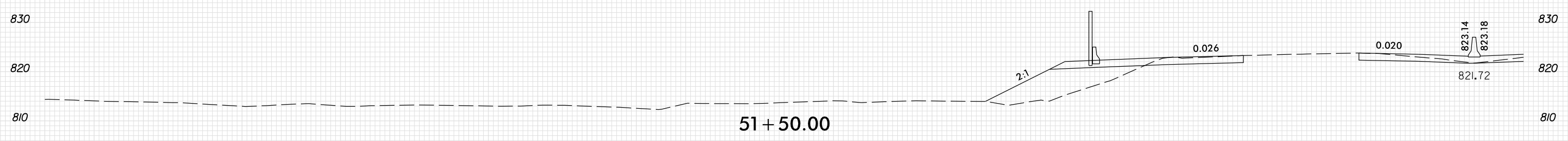

51 + 50.00

-Y15-

290 280 270 260 250 240 230 220 210 200 190 180 170 160 150 140 130 120 110 100 90 80 70 60 50 40 30 20 10 0 10

8/23/99

290 280 270 260 250 240 230 220 210 200 190 180 170 160 150 140 130 120 110 100 90 80 70 60 50 40 30 20 10 0 10

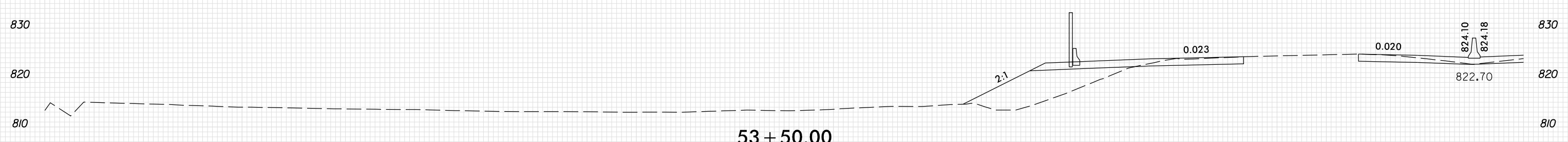
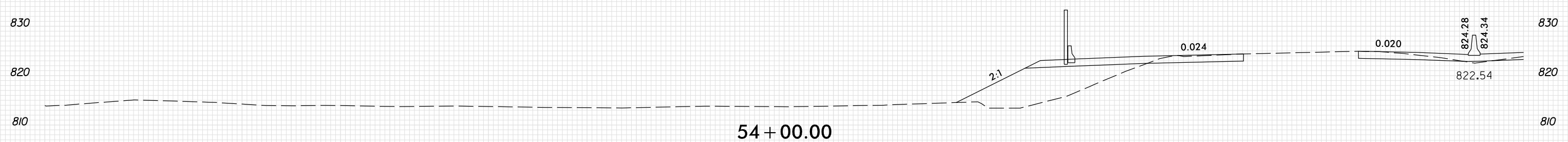
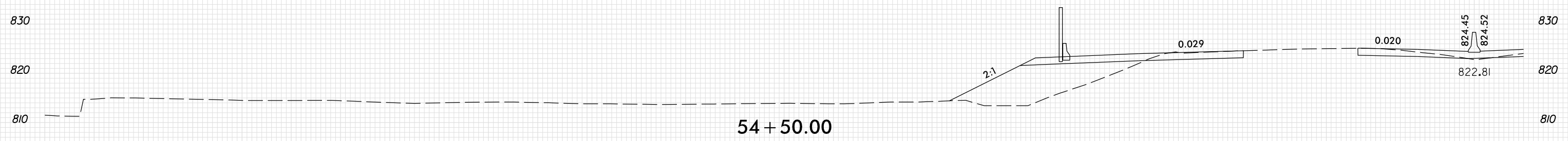
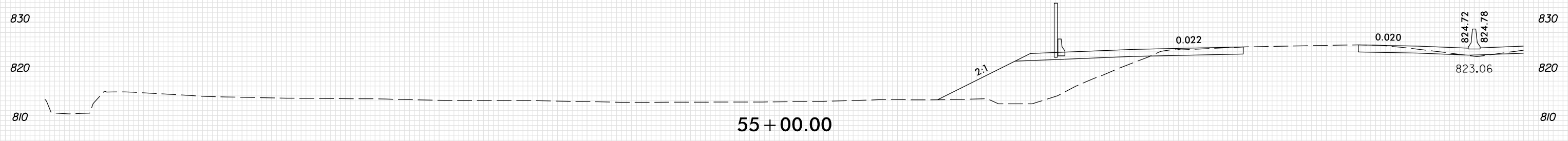

-Y15-

290 280 270 260 250 240 230 220 210 200 190 180 170 160 150 140 130 120 110 100 90 80 70 60 50 40 30 20 10 0 10

PLOT DRIVER: NCD01_pdf_color_eng_100.plt
 USER: SPEREIRA
 DATE: 6/10/2021
 TIME: 2:21:35 PM
 FILE: \

8/23/99

	PROJ. REFERENCE NO.	SHEET NO.
	U-2579AB	X-249

290 280 270 260 250 240 230 220 210 200 190 180 170 160 150 140 130 120 110 100 90 80 70 60 50 40 30 20 10 0 10

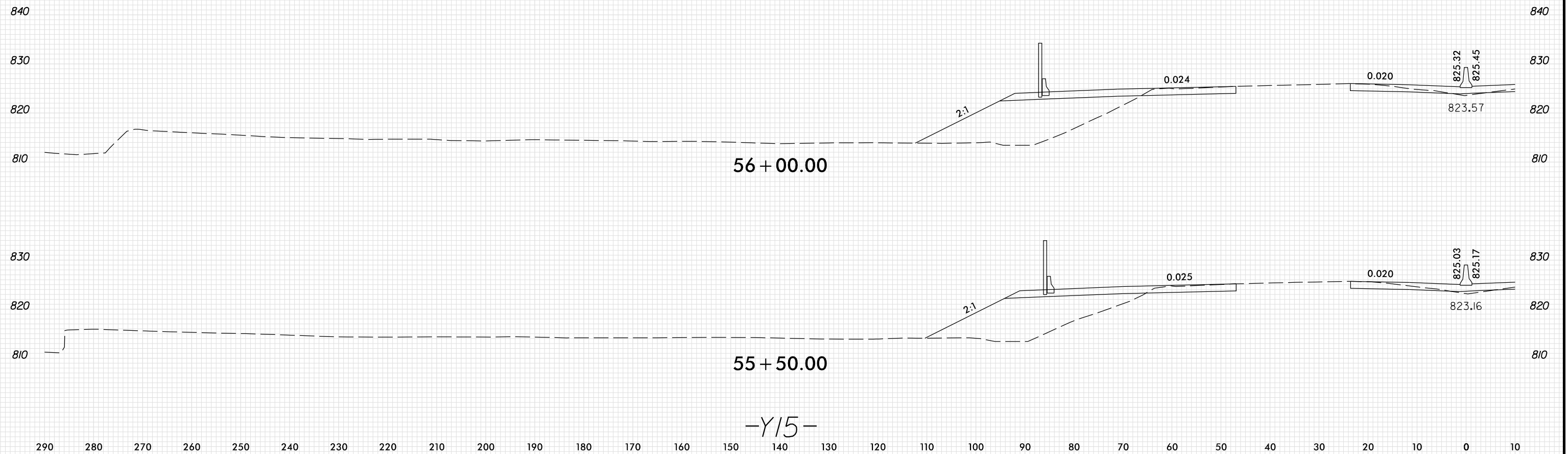

56 + 00.00

55 + 50.00

-Y15-

PLOT DRIVER: NCD01...pdf_color_eng_100.plt
 USER: SPEREIRA
 DATE: 6/10/2021
 TIME: 2:21:36 PM
 FILE: \

8/23/99

0 5 10	PROJ. REFERENCE NO.	SHEET NO.
	U-2579AB	X-250

10 0 10 20 30 40 50 60 70 80 90 100 110 120 130 140 150 160 170 180 190 200 210 220 230 240 250 260 270 280 290

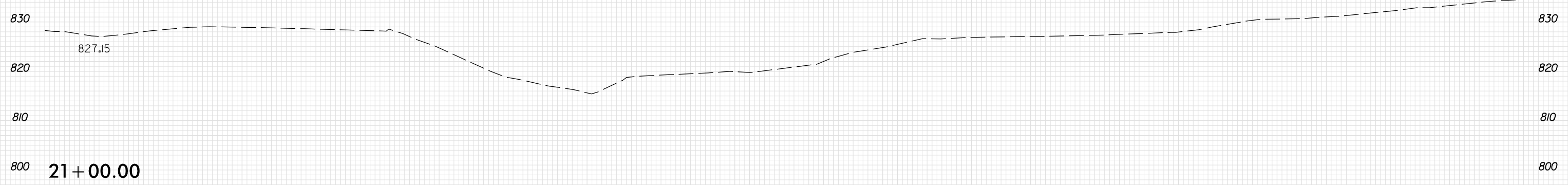
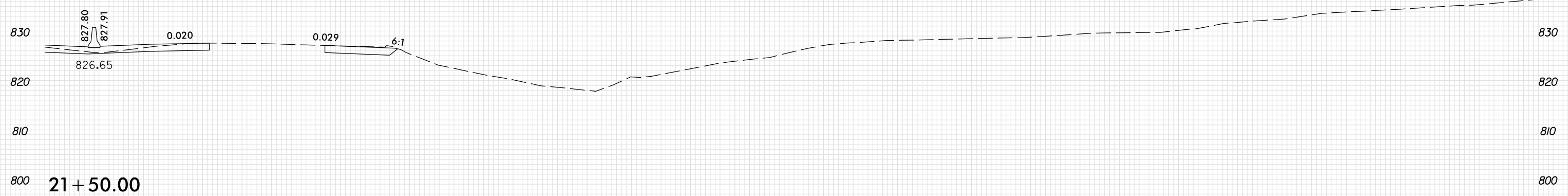
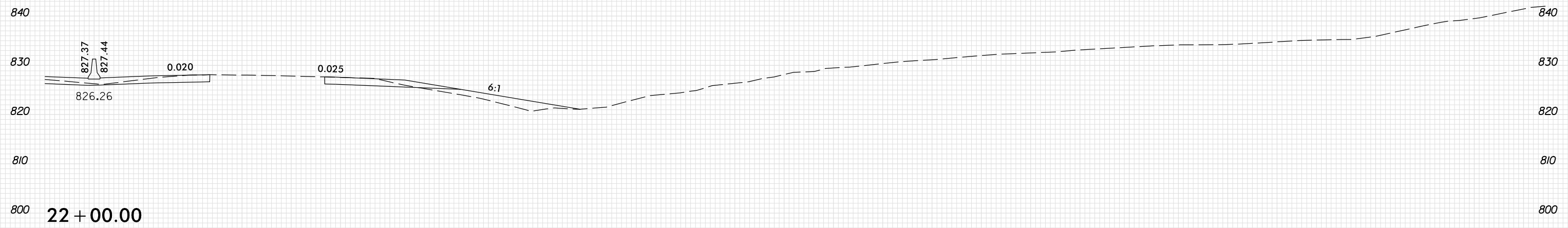

-Y15-

10 0 10 20 30 40 50 60 70 80 90 100 110 120 130 140 150 160 170 180 190 200 210 220 230 240 250 260 270 280 290

PLOT DRIVER: NCD01_pdf_color_eng_100.plt
 USER: SPEREIRA
 DATE: 6/10/2021
 TIME: 2:24:52 PM
 FILE: \

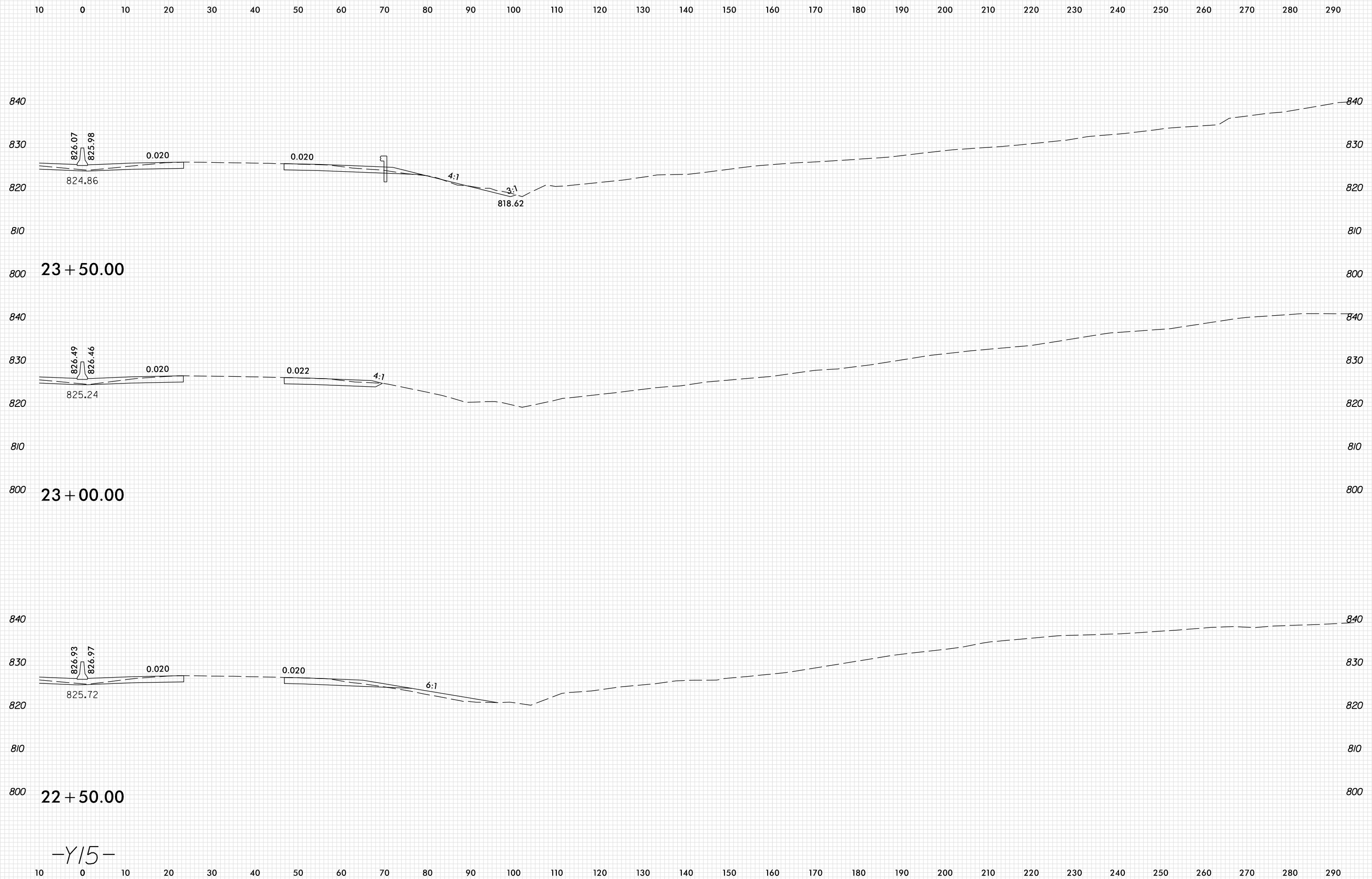

10 0 10 20 30 40 50 60 70 80 90 100 110 120 130 140 150 160 170 180 190 200 210 220 230 240 250 260 270 280 290

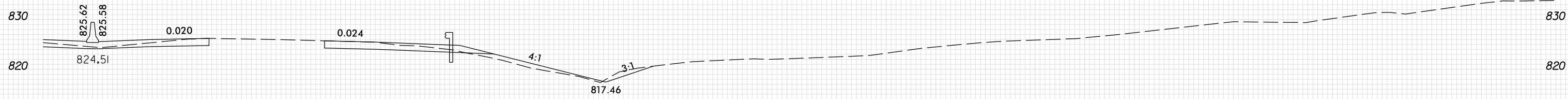
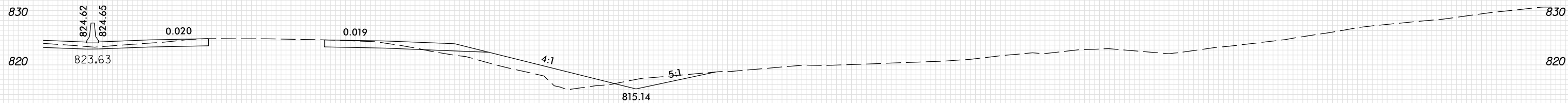
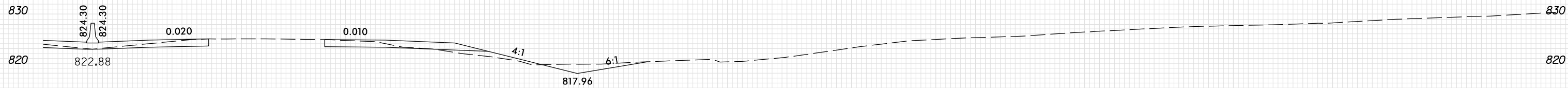

24+00.00

-Y15-

10 0 10 20 30 40 50 60 70 80 90 100 110 120 130 140 150 160 170 180 190 200 210 220 230 240 250 260 270 280 290

8/23/99

0 5 10	PROJ. REFERENCE NO.	SHEET NO.
	U-2579AB	X-253

10 0 10 20 30 40 50 60 70 80 90 100 110 120 130 140 150 160 170 180 190 200 210 220 230 240 250 260 270 280 290

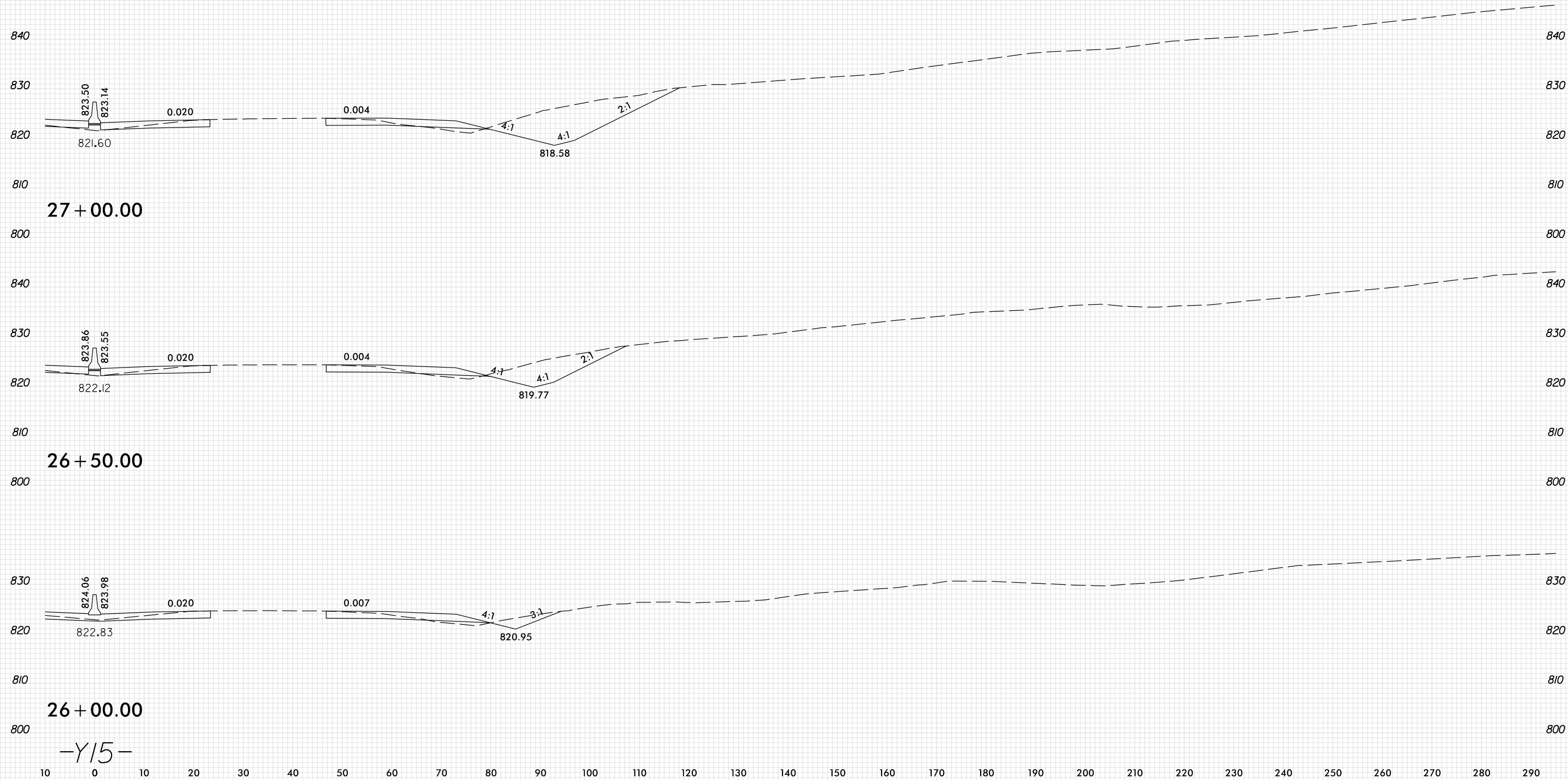

27 + 00.00

26 + 50.00

26 + 00.00

-Y15-

PLOT DRIVER: NCD01_pdf_color_eng_100.plt
 USER: SPEREIRA
 DATE: 6/10/2021
 TIME: 2:24:55 PM
 FILE: \

8/23/99

10 0 10 20 30 40 50 60 70 80 90 100 110 120 130 140 150 160 170 180 190 200 210 220 230 240 250 260 270 280 290

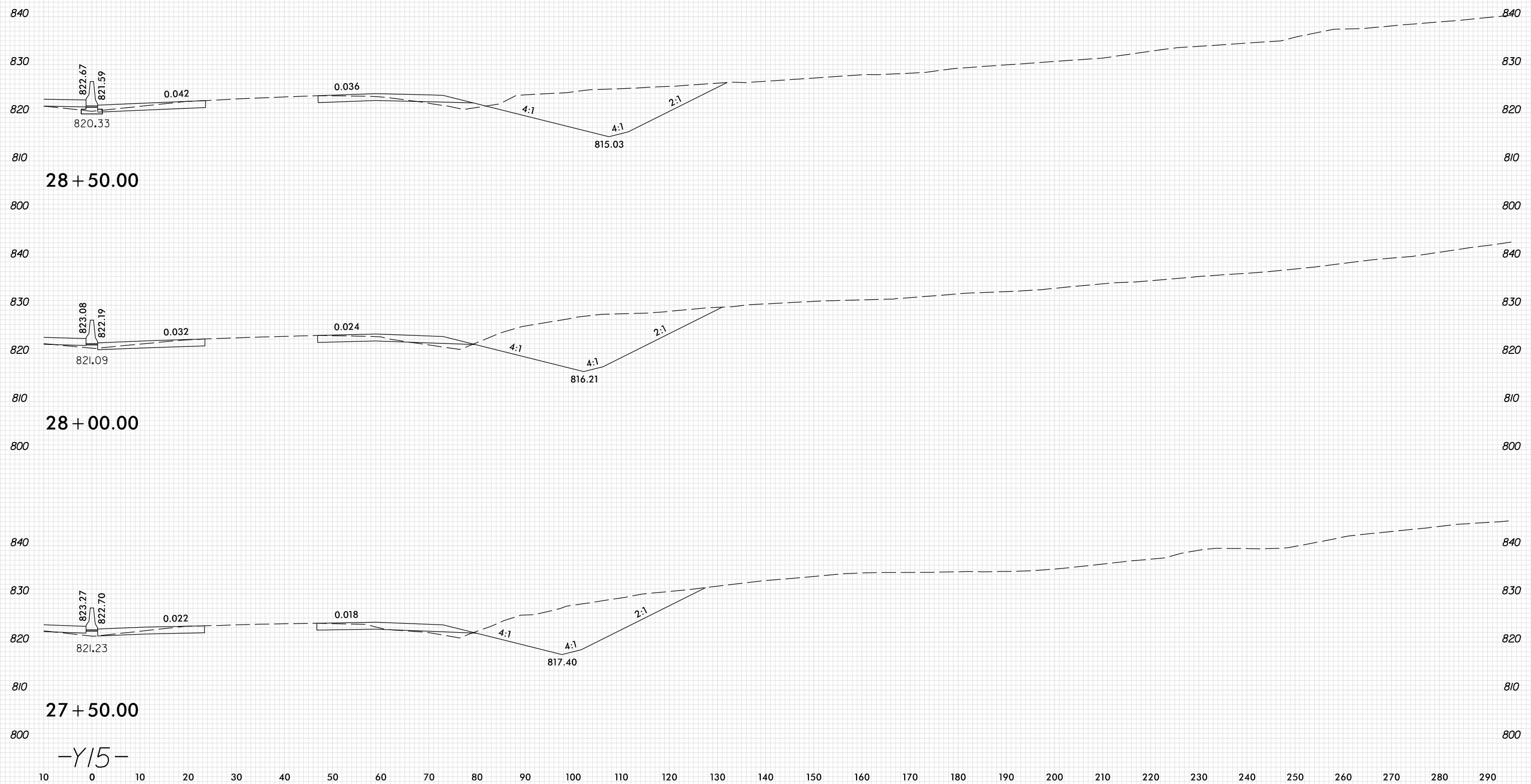

PLOT DRIVER: NCD01_pdf_color_eng_100.plt
 USER: SPEREIRA
 DATE: 6/10/2021
 TIME: 2:24:56 PM
 FILE: \

8/23/99

0 5 10	PROJ. REFERENCE NO.	SHEET NO.
	U-2579AB	X-255

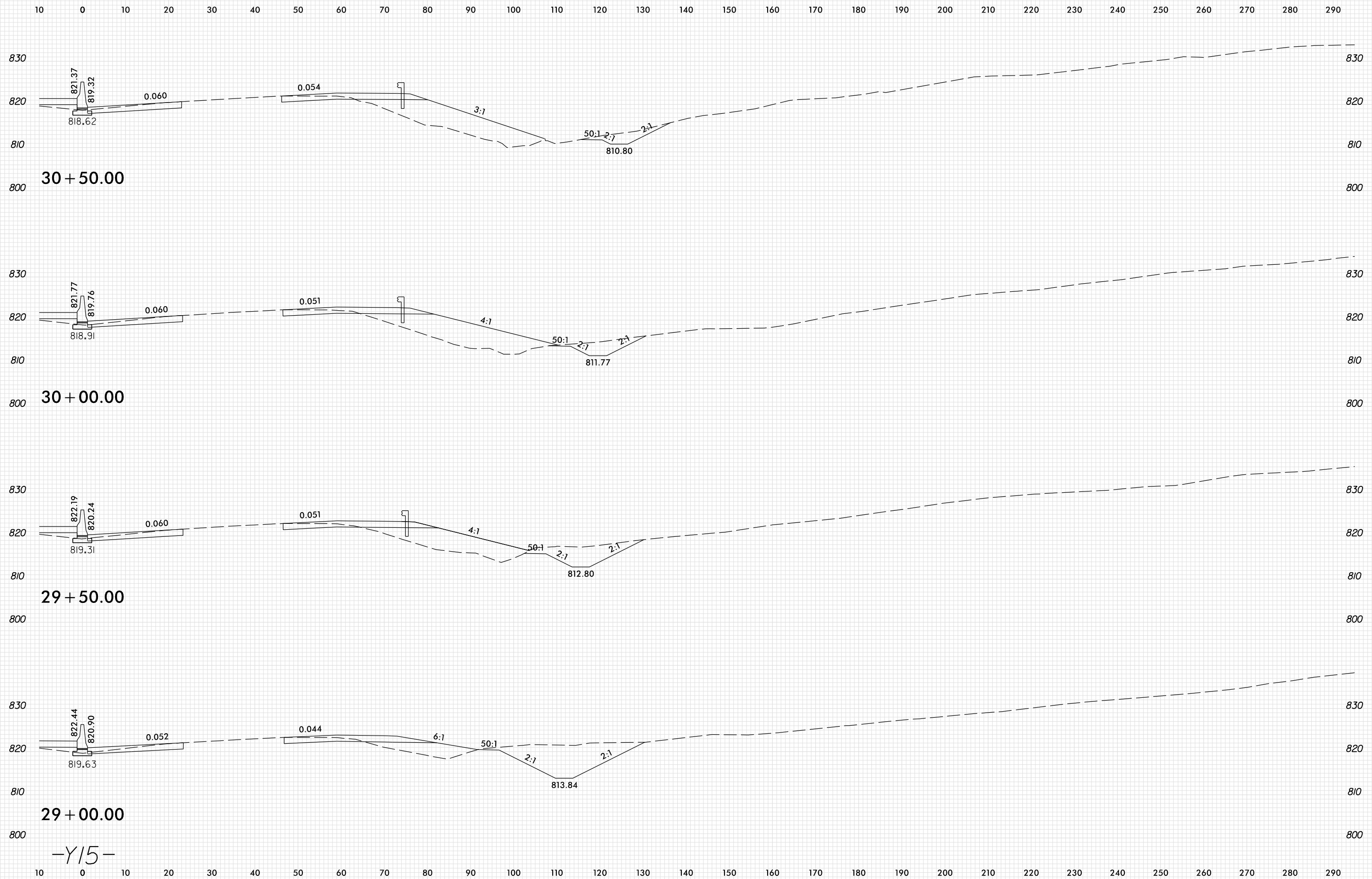

PLOT DRIVER: NCD01_pdf_color_eng_100.plt
 USER: SPEREIRA
 DATE: 6/10/2021
 TIME: 2:24:56 PM

-Y15-

8/23/99

10 0 10 20 30 40 50 60 70 80 90 100 110 120 130 140 150 160 170 180 190 200 210 220 230 240 250 260 270 280 290

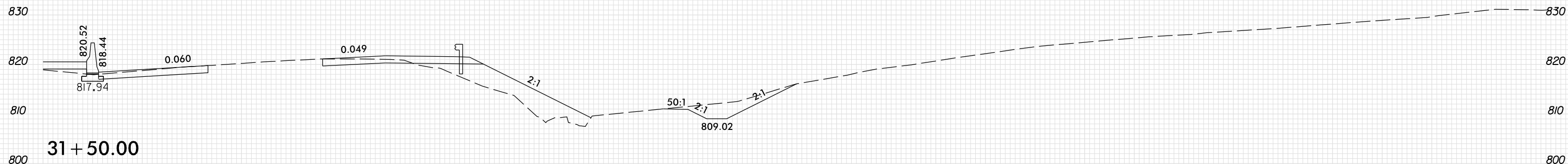
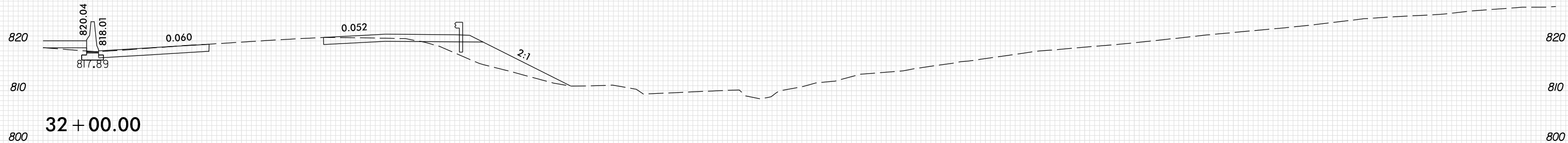
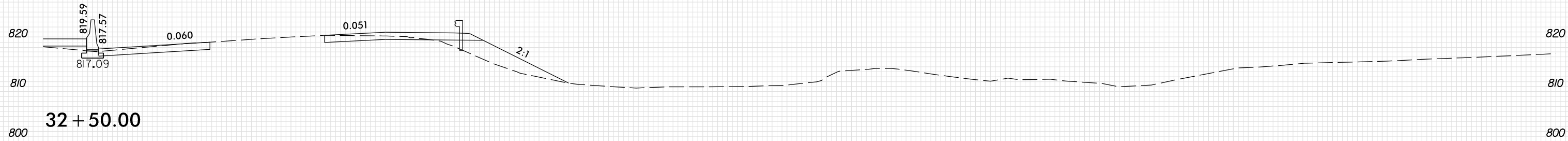

-Y15-

10 0 10 20 30 40 50 60 70 80 90 100 110 120 130 140 150 160 170 180 190 200 210 220 230 240 250 260 270 280 290

PLOT DRIVER: NCD01_pdf_color_eng_100.plt
USER: SPEREIRA
DATE: 6/10/2021
TIME: 2:24:57 PM
FILE: \

8/23/99

10 0 10 20 30 40 50 60 70 80 90 100 110 120 130 140 150 160 170 180 190 200 210 220 230 240 250 260 270 280 290

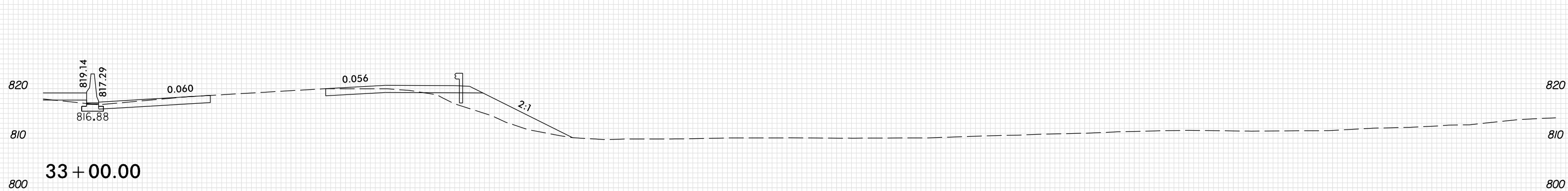
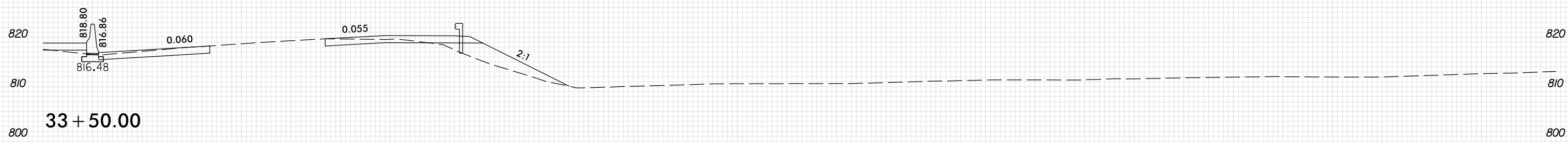
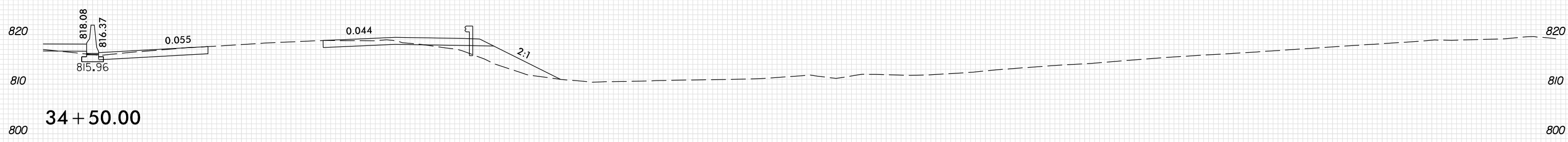
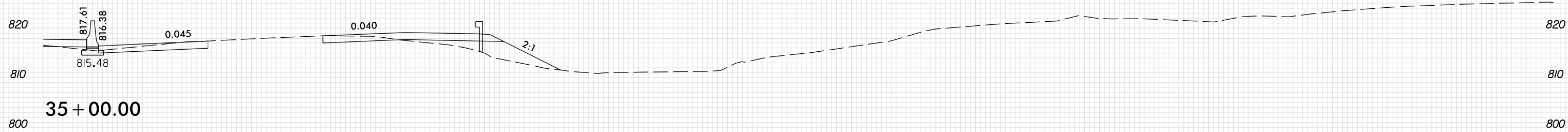

-Y15-

10 0 10 20 30 40 50 60 70 80 90 100 110 120 130 140 150 160 170 180 190 200 210 220 230 240 250 260 270 280 290

8/23/99

0 5 10	PROJ. REFERENCE NO.	SHEET NO.
	U-2579AB	X-258

10 0 10 20 30 40 50 60 70 80 90 100 110 120 130 140 150 160 170 180 190 200 210 220 230 240 250 260 270 280 290

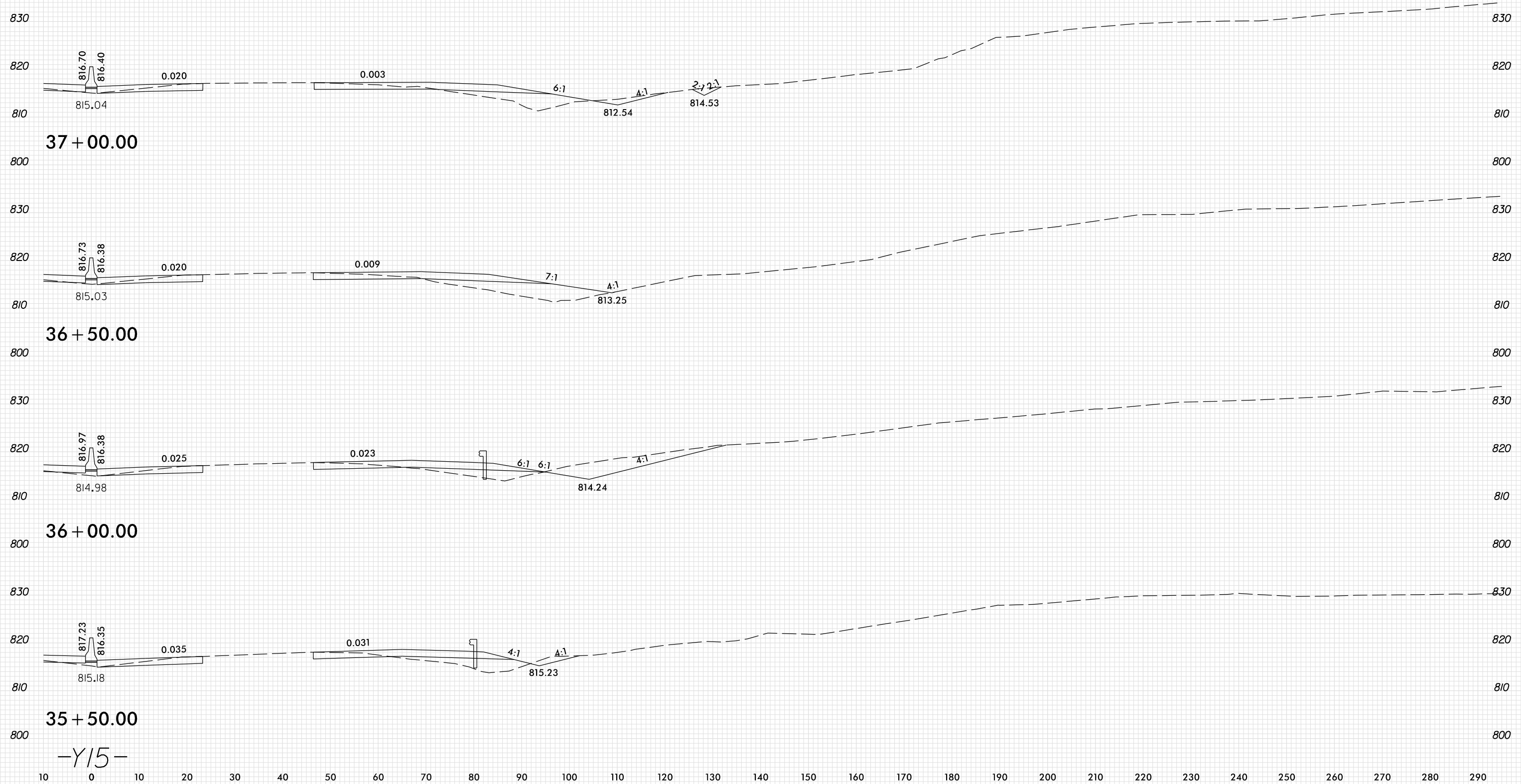

10 0 10 20 30 40 50 60 70 80 90 100 110 120 130 140 150 160 170 180 190 200 210 220 230 240 250 260 270 280 290

PLOT DRIVER: NCD01_pdf_color_eng_100.plt
 USER: SPEREIRA
 DATE: 6/10/2021
 TIME: 2:24:58 PM
 FILE: \

-Y15-

8/23/99

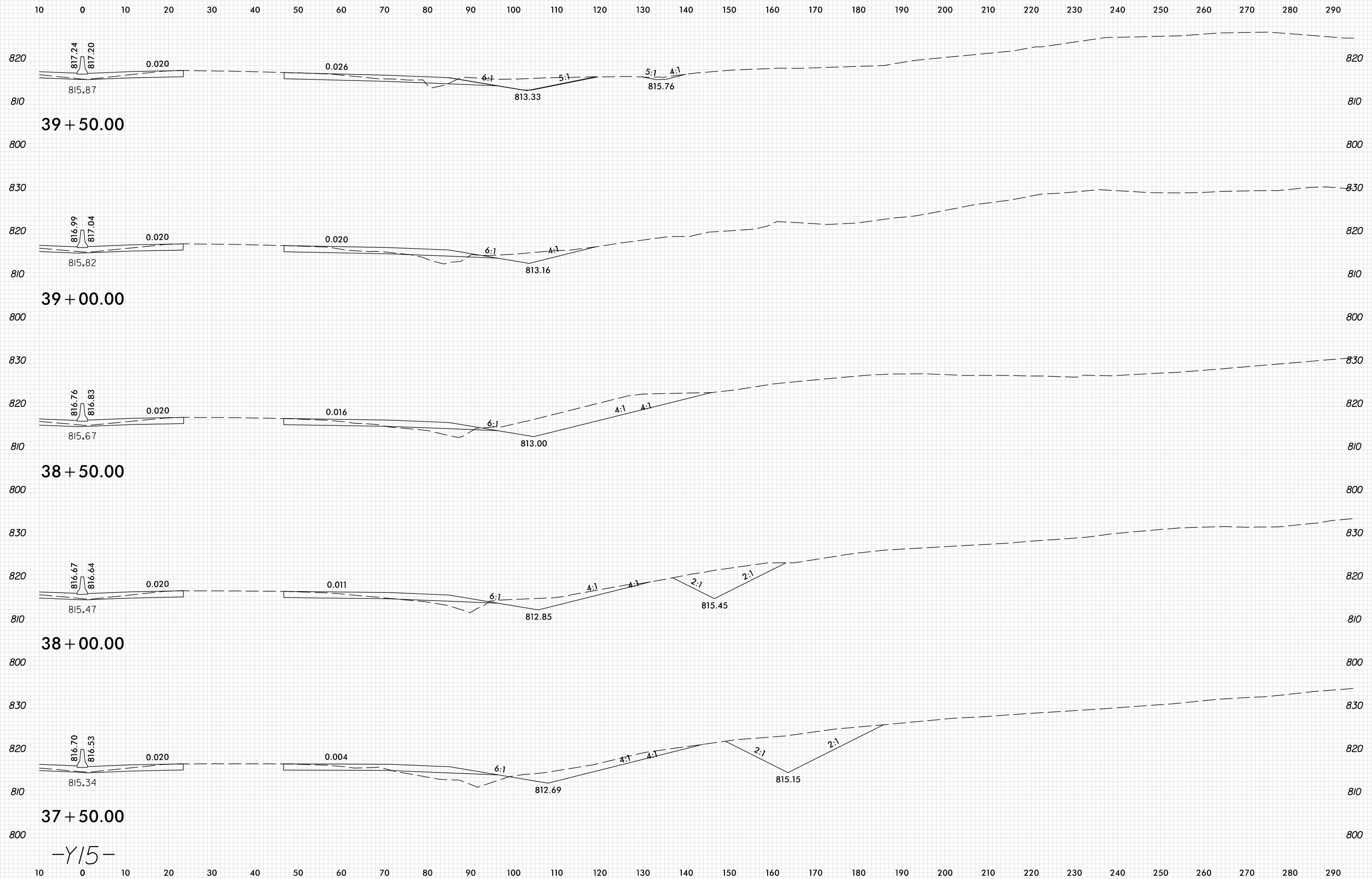

PLOT DRIVER: NCDOT_pdf_color_eng_100.plt
 USER: SPEREIRA
 DATE: 6/10/2021
 TIME: 2:24:59 PM
 FILE: \

8/23/99

0 5 10	PROJ. REFERENCE NO.	SHEET NO.
	U-2579AB	X-260

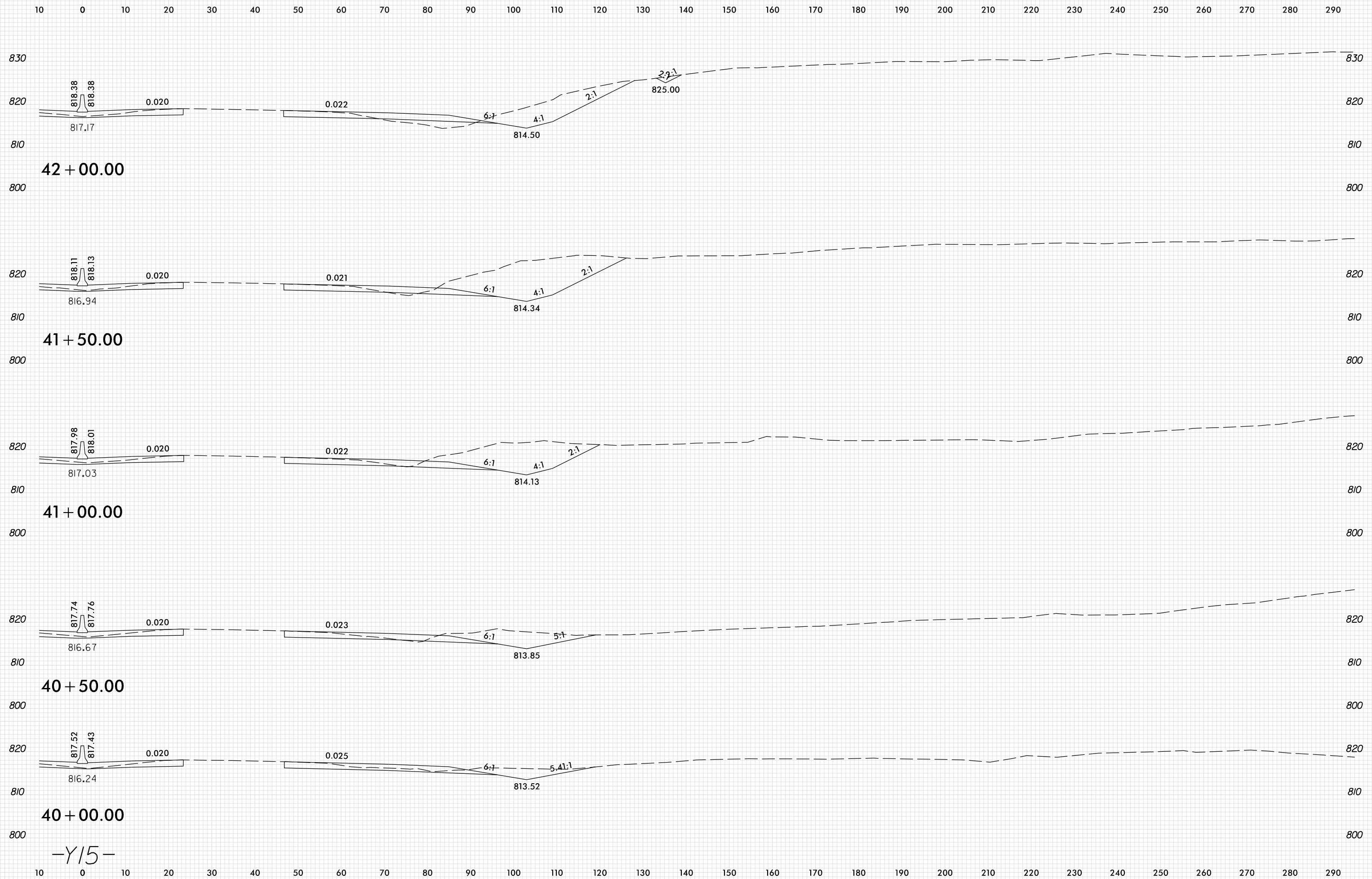

PLOT DRIVER: NCD01_pdf_color_eng_100.plt
 USER: SPEREIRA
 DATE: 6/10/2021
 TIME: 2:24:59 PM
 FILE: \

-Y15-

8/23/99

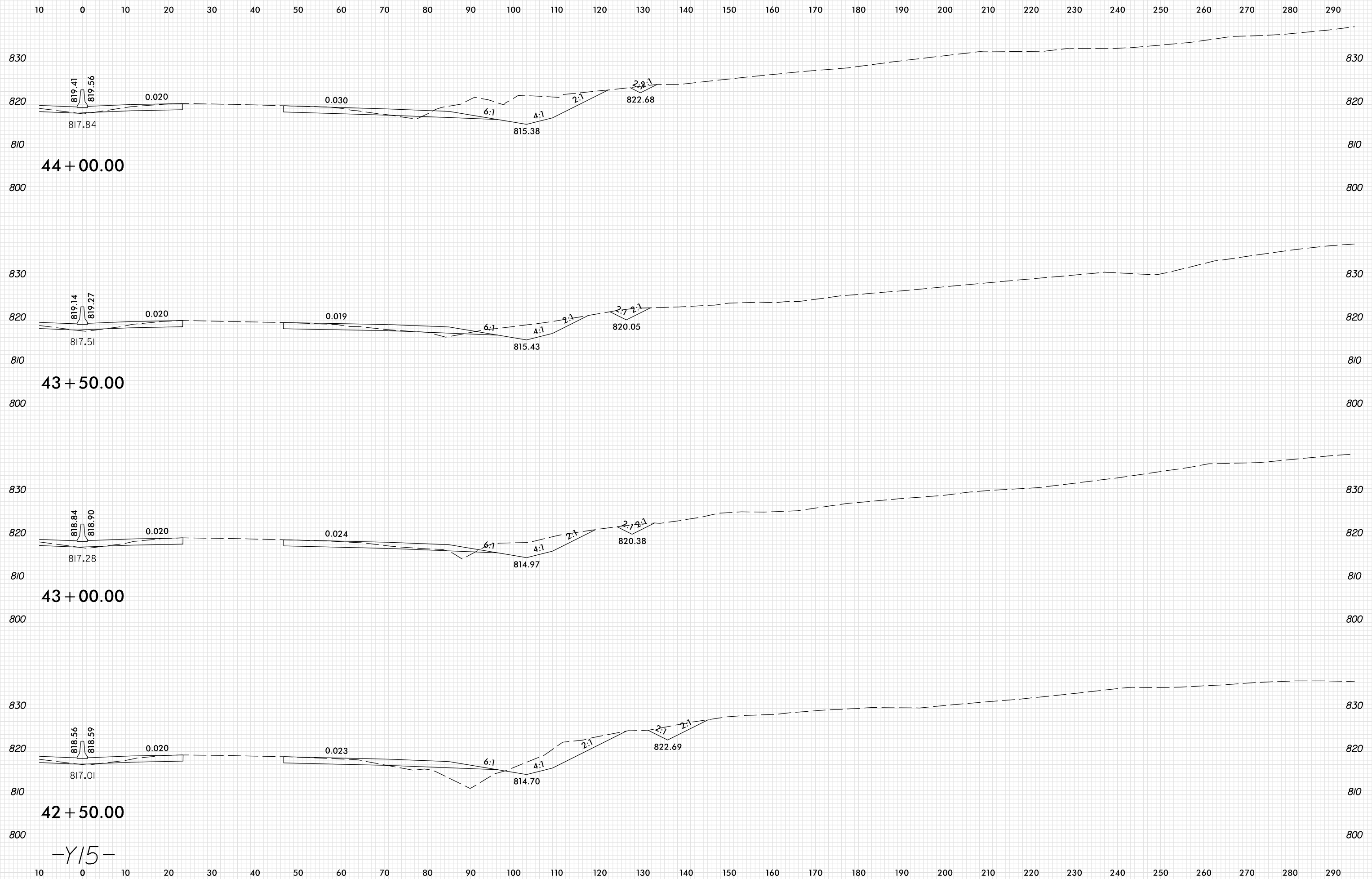

PLOT DRIVER: NCDOT_pdf_color_eng_100.plt
 USER: SPEREIRA
 DATE: 6/10/2021
 TIME: 2:22:00 PM
 FILE: \

-Y15-

8/23/99

10 0 10 20 30 40 50 60 70 80 90 100 110 120 130 140 150 160 170 180 190 200 210 220 230 240 250 260 270 280 290

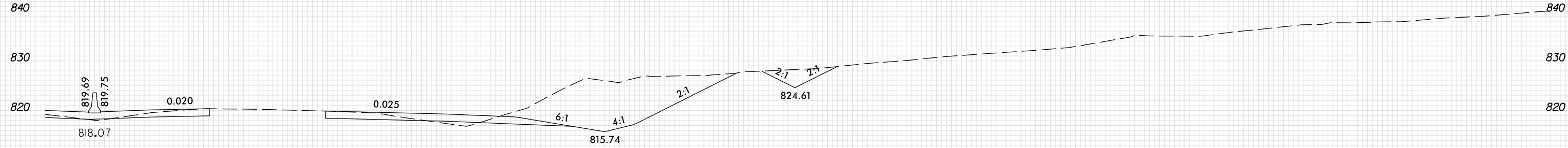
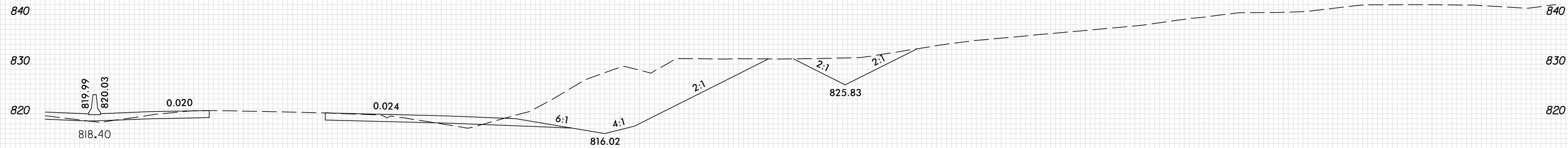
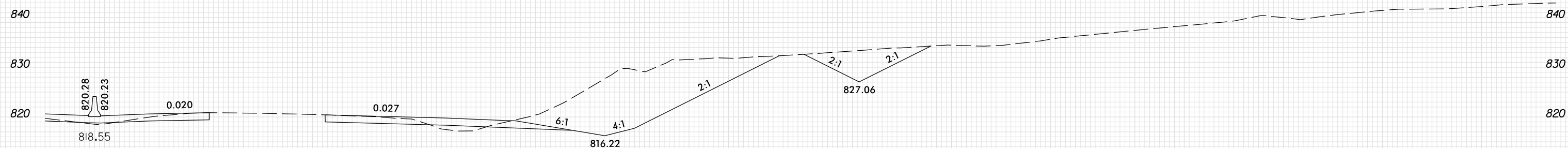

44 + 50.00

-Y15-

10 0 10 20 30 40 50 60 70 80 90 100 110 120 130 140 150 160 170 180 190 200 210 220 230 240 250 260 270 280 290

PLOT DRIVER: NCD01_pdf_color_eng_100.plt
USER: SPEREIRA
DATE: 6/10/2021
TIME: 2:22:01 PM
FILE: \

8/23/99

10 0 10 20 30 40 50 60 70 80 90 100 110 120 130 140 150 160 170 180 190 200 210 220 230 240 250 260 270 280 290

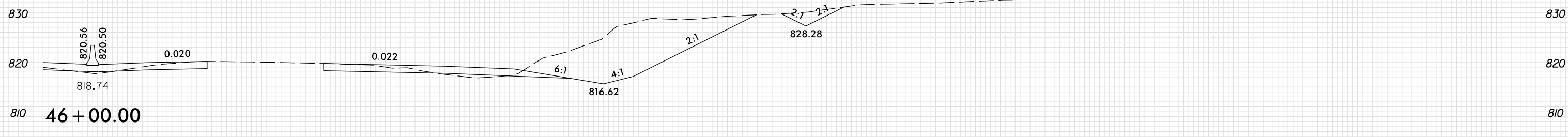
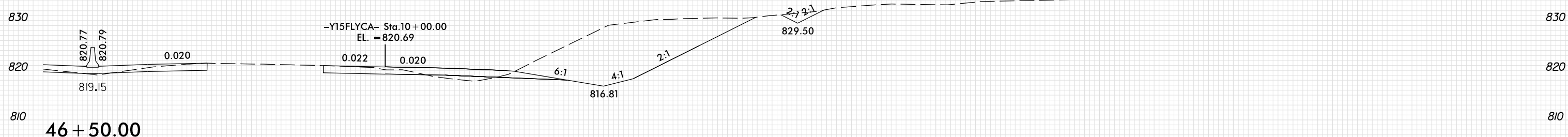
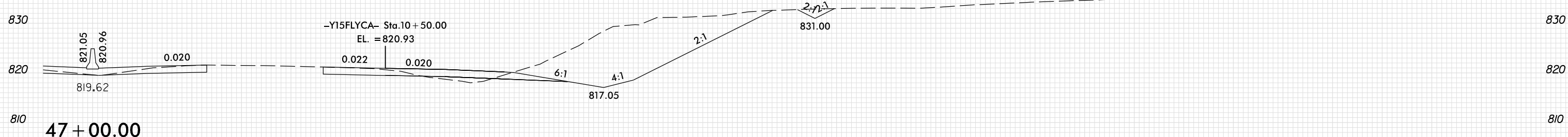
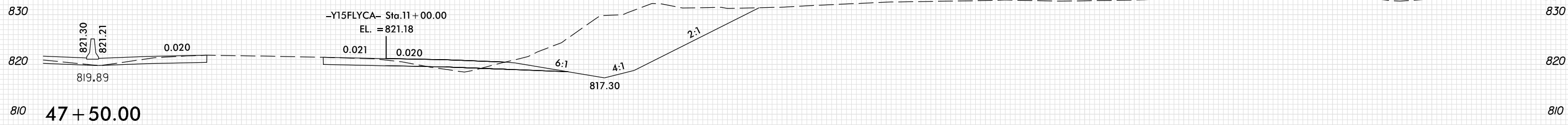

-Y15-

10 0 10 20 30 40 50 60 70 80 90 100 110 120 130 140 150 160 170 180 190 200 210 220 230 240 250 260 270 280 290

PLOT DRIVER: NCDOT_pdf_color_eng_100.plt
USER: SPEREIRA
DATE: 6/10/2021
TIME: 2:22:01 PM
FILE: \

8/23/99

10 0 10 20 30 40 50 60 70 80 90 100 110 120 130 140 150 160 170 180 190 200 210 220 230 240 250 260 270 280 290

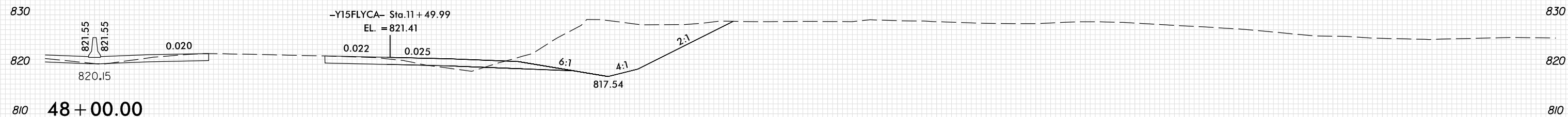
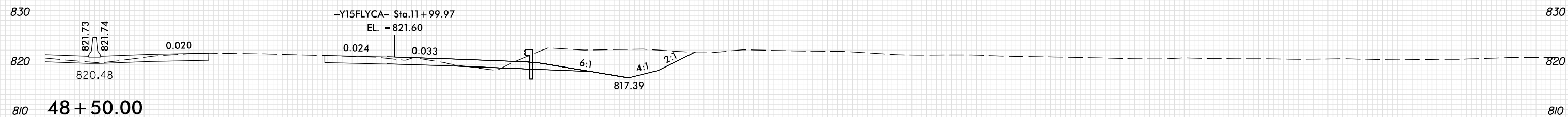
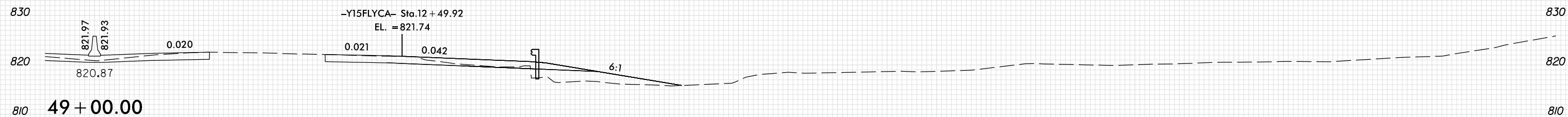
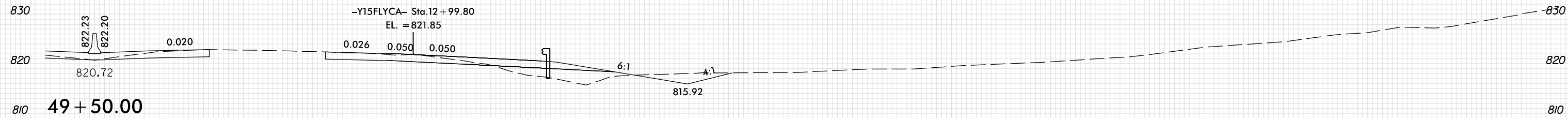

-Y15-

10 0 10 20 30 40 50 60 70 80 90 100 110 120 130 140 150 160 170 180 190 200 210 220 230 240 250 260 270 280 290

PLOT DRIVER: NCD01...pdf_color_eng_100.plt
USER: SPEREIRA
DATE: 6/10/2021
TIME: 2:22:02 PM

8/23/99

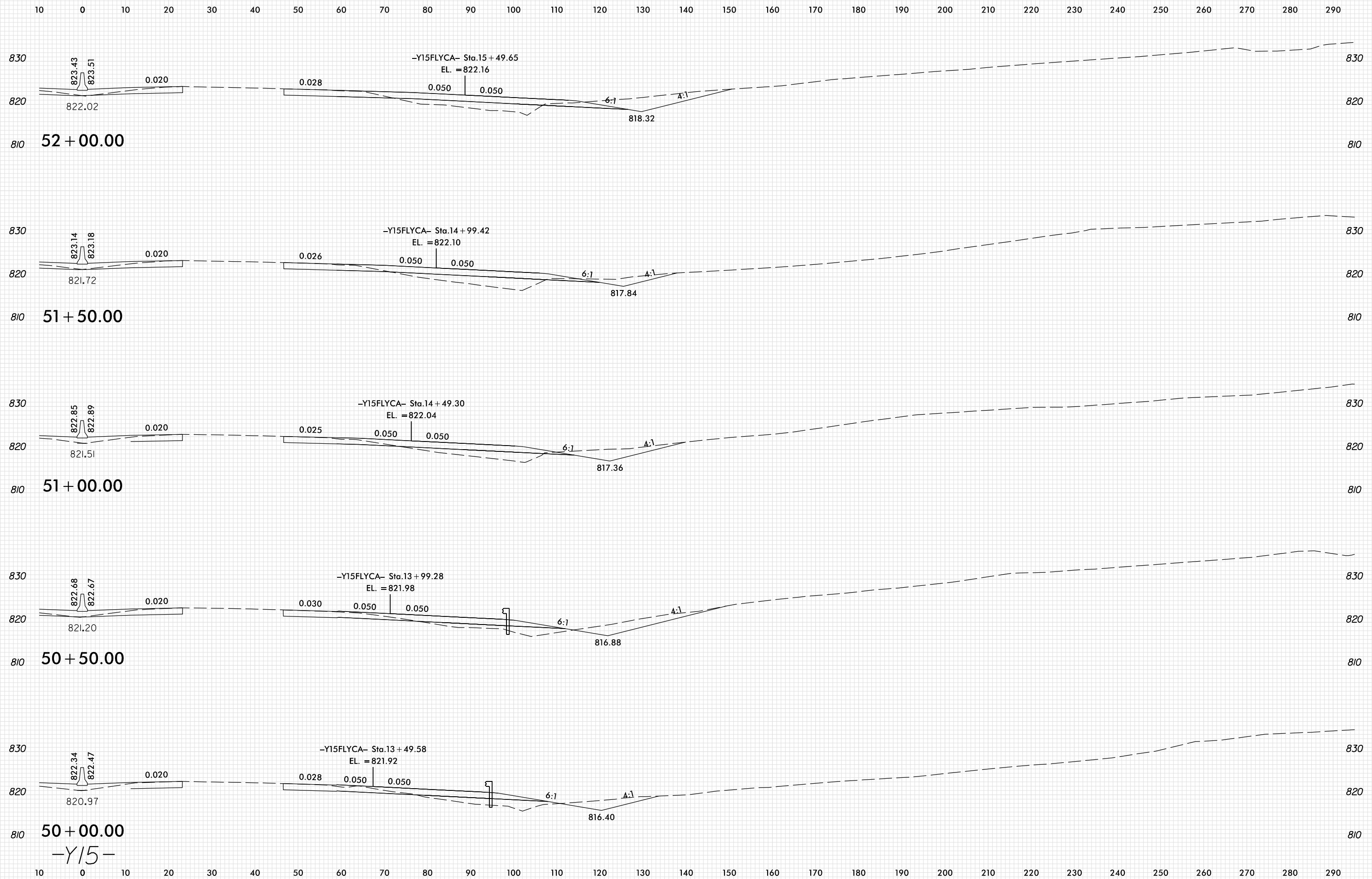

PLOT DRIVER: NCDOT_pdf_color_eng_100.plt
 USER: SPEREIRA
 DATE: 6/10/2021
 TIME: 2:22:03 PM
 FILE: \

50+00.00
 -Y15-

8/23/99

10 0 10 20 30 40 50 60 70 80 90 100 110 120 130 140 150 160 170 180 190 200 210 220 230 240 250 260 270 280 290

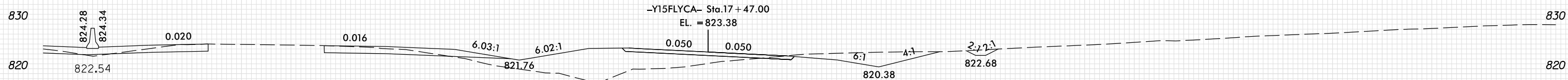

810 54 + 00.00

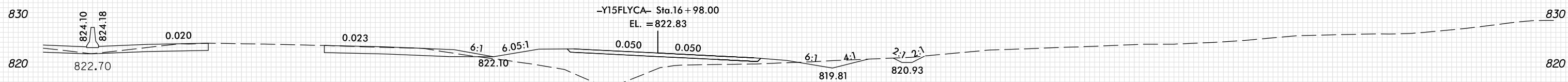

810 53 + 50.00

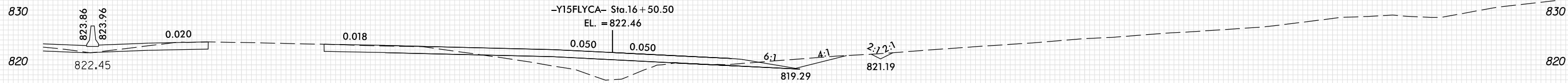

810 53 + 00.00



810 52 + 50.00

-Y15-

10 0 10 20 30 40 50 60 70 80 90 100 110 120 130 140 150 160 170 180 190 200 210 220 230 240 250 260 270 280 290

PLOT DRIVER: NCDOT_pdf_color_eng_100.plt
USER: SPEREIRA
DATE: 6/10/2021
TIME: 2:22:03 PM
FILE: \

8/23/99

10 0 10 20 30 40 50 60 70 80 90 100 110 120 130 140 150 160 170 180 190 200 210 220 230 240 250 260 270 280 290

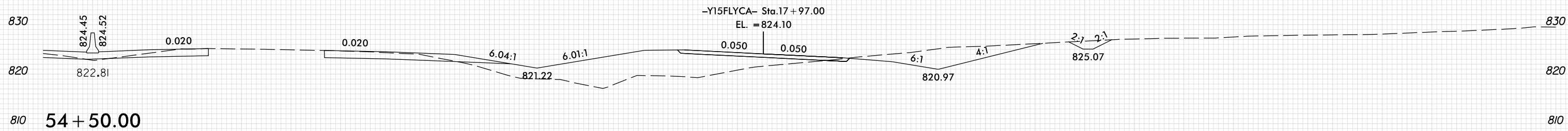
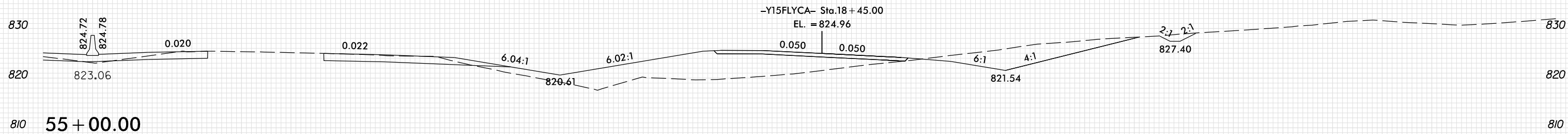
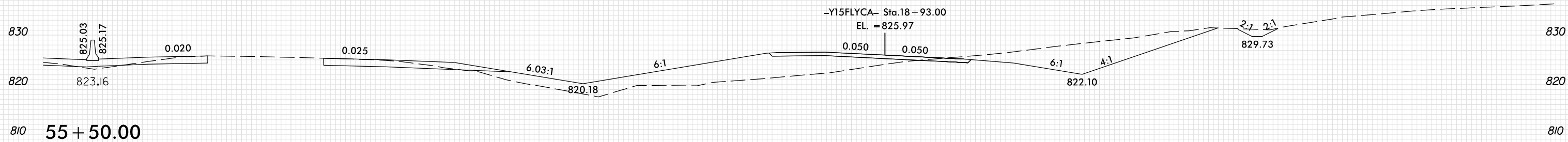
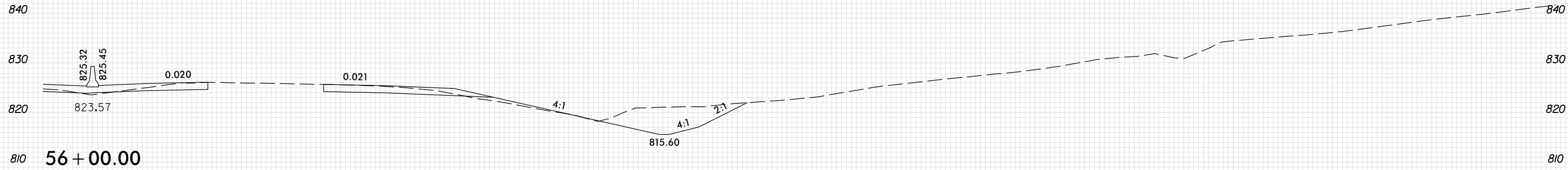

-Y15-

10 0 10 20 30 40 50 60 70 80 90 100 110 120 130 140 150 160 170 180 190 200 210 220 230 240 250 260 270 280 290

PLOT DRIVER: NCDOT_pdf_color_eng_100.plt
USER: SPEREIRA
DATE: 6/10/2021
TIME: 2:22:04 PM
FILE: \

8/23/99

0 5 10	PROJ. REFERENCE NO.	SHEET NO.
	U-2579AB	X-268

290 280 270 260 250 240 230 220 210 200 190 180 170 160 150 140 130 120 110 100 90 80 70 60 50 40 30 20 10 0 10

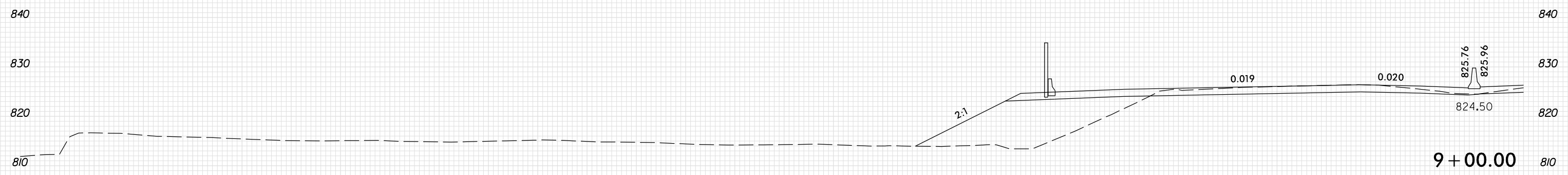

9 + 00.00

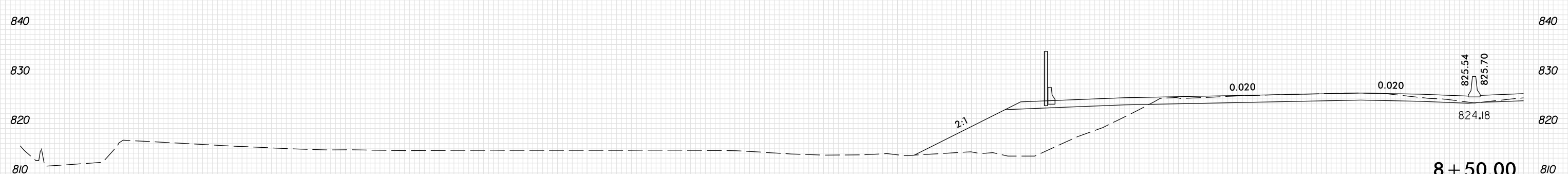

8 + 50.00



8 + 00.00

-Y15REV-

290 280 270 260 250 240 230 220 210 200 190 180 170 160 150 140 130 120 110 100 90 80 70 60 50 40 30 20 10 0 10

PLOT DRIVER: NCDOT_pdf_color_eng_100.plt
 USER: SPEREIRA
 DATE: 6/10/2021
 TIME: 2:22:38 PM
 FILE: \

8/23/99

0 5 10	PROJ. REFERENCE NO.	SHEET NO.
	U-2579AB	X-269

290 280 270 260 250 240 230 220 210 200 190 180 170 160 150 140 130 120 110 100 90 80 70 60 50 40 30 20 10 0 10

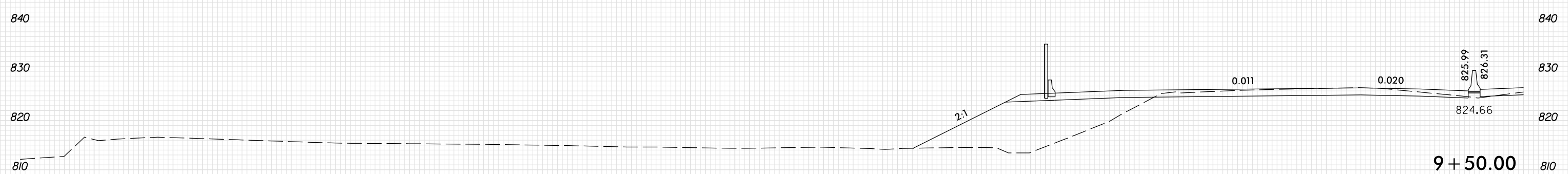
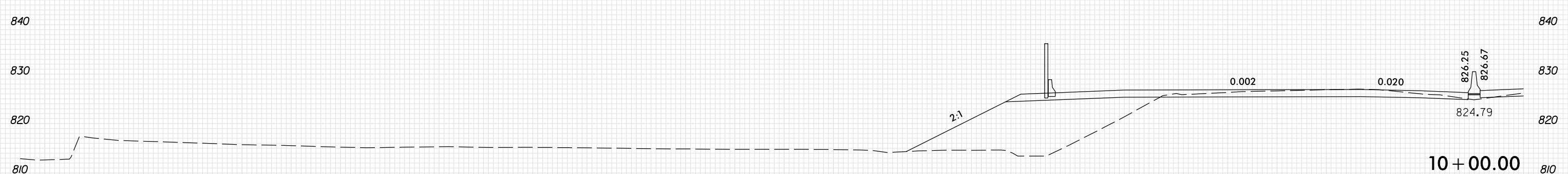
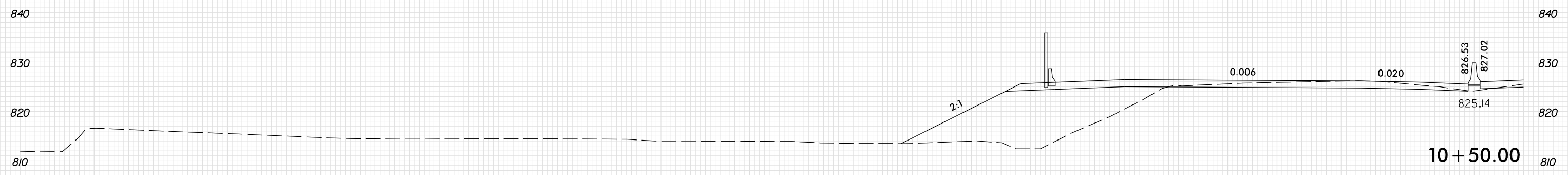

-Y15REV-

PLOT DRIVER: NCDOT_pdf_color_eng_100.plt
 USER: SPEREIRA
 DATE: 6/10/2021
 TIME: 2:22:39 PM
 FILE: \

290 280 270 260 250 240 230 220 210 200 190 180 170 160 150 140 130 120 110 100 90 80 70 60 50 40 30 20 10 0 10

8/23/99

0 5 10	PROJ. REFERENCE NO.	SHEET NO.
	U-2579AB	X-270

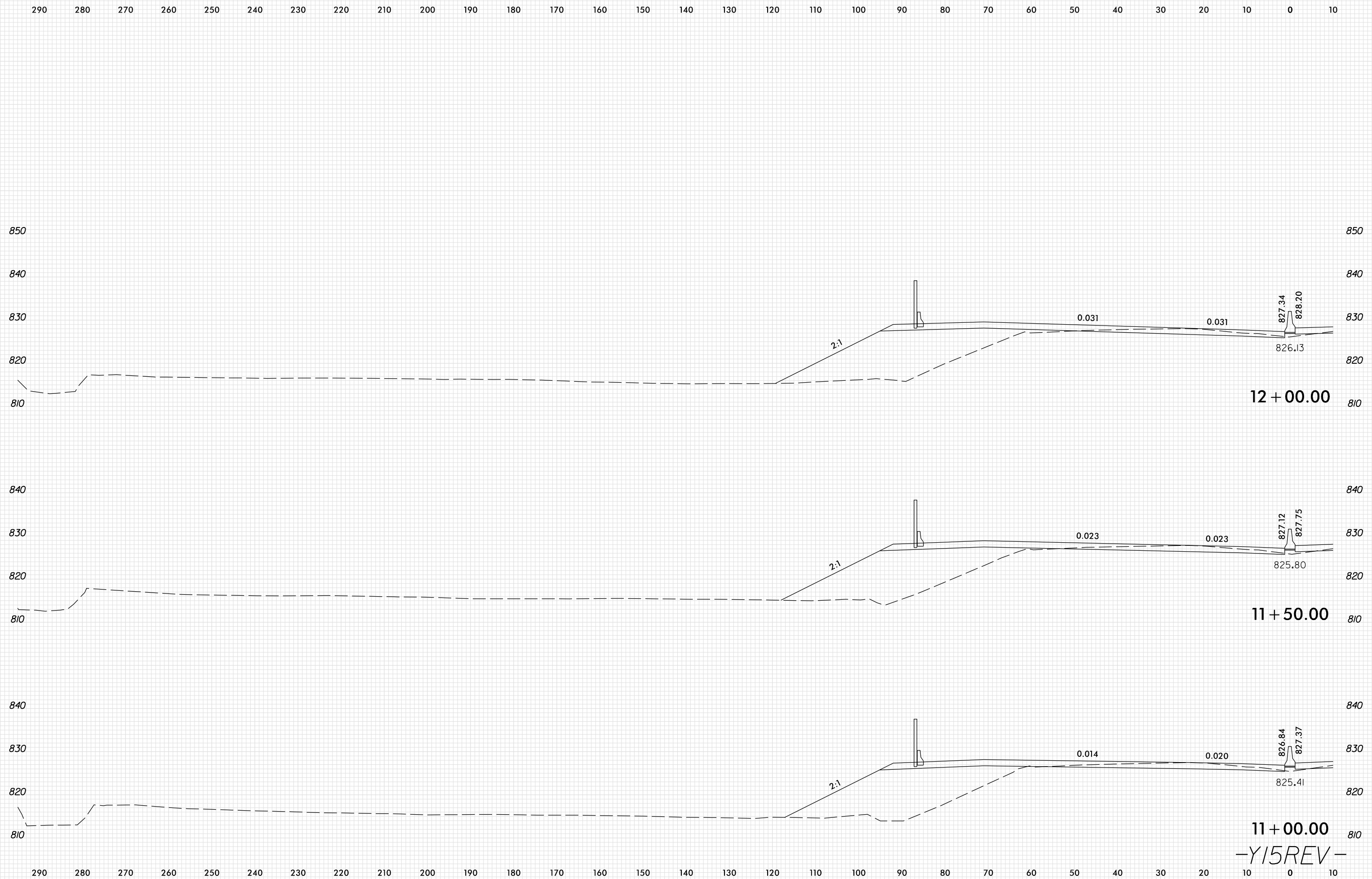

PLOT DRIVER: NCDOT_pdf_color_eng_100.plt
 USER: SPEREIRA
 DATE: 6/10/2021
 TIME: 2:22:39 PM
 FILE: \

11+00.00
 -Y15REV-

8/23/99

0 5 10	PROJ. REFERENCE NO.	SHEET NO.
	U-2579AB	X-271

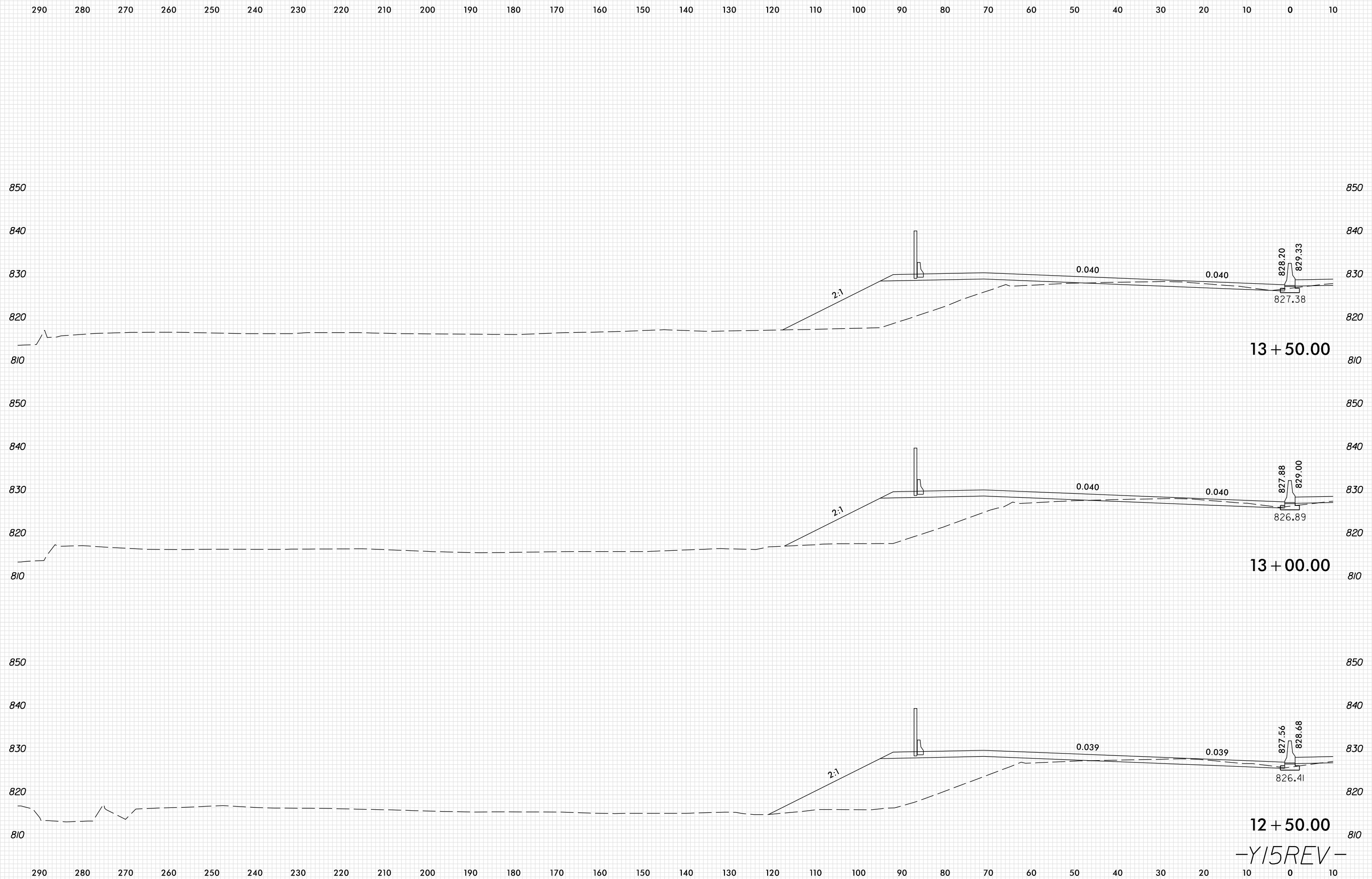

PLOT DRIVER: NCD01_pdr_color_eng_100.plt
 USER: SPEREIRA
 DATE: 6/10/2021
 TIME: 2:22:40 PM

-Y15REV-

8/23/99

0 5 10	PROJ. REFERENCE NO.	SHEET NO.
	U-2579AB	X-272

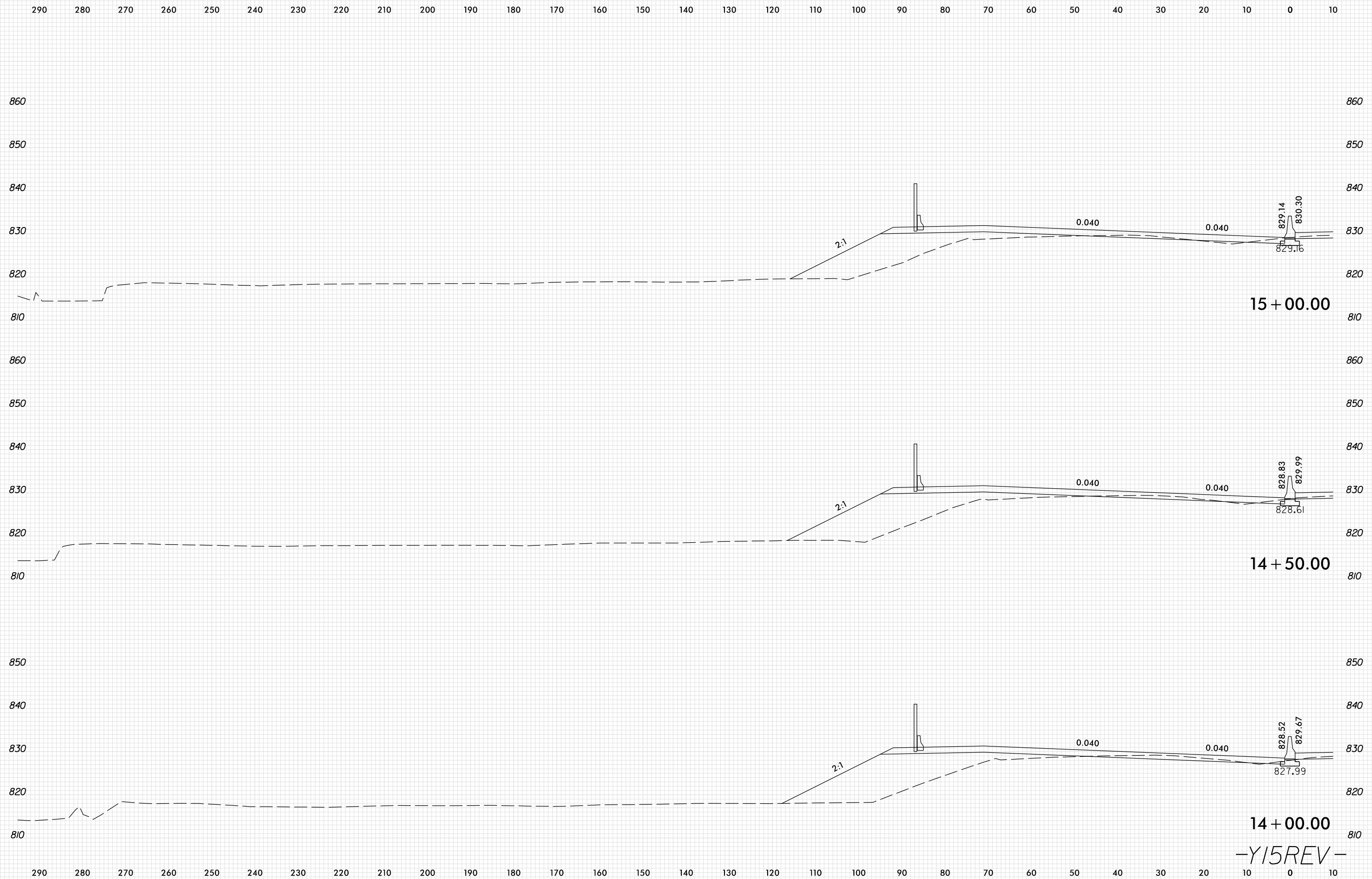

PLOT DRIVER: NCDOT_pdf_color_eng_100.plt
 USER: SPEREIRA
 DATE: 6/10/2021
 TIME: 2:22:41 PM
 FILE: \

-Y15REV-

8/23/99

	PROJ. REFERENCE NO.	SHEET NO.
	U-2579AB	X-273

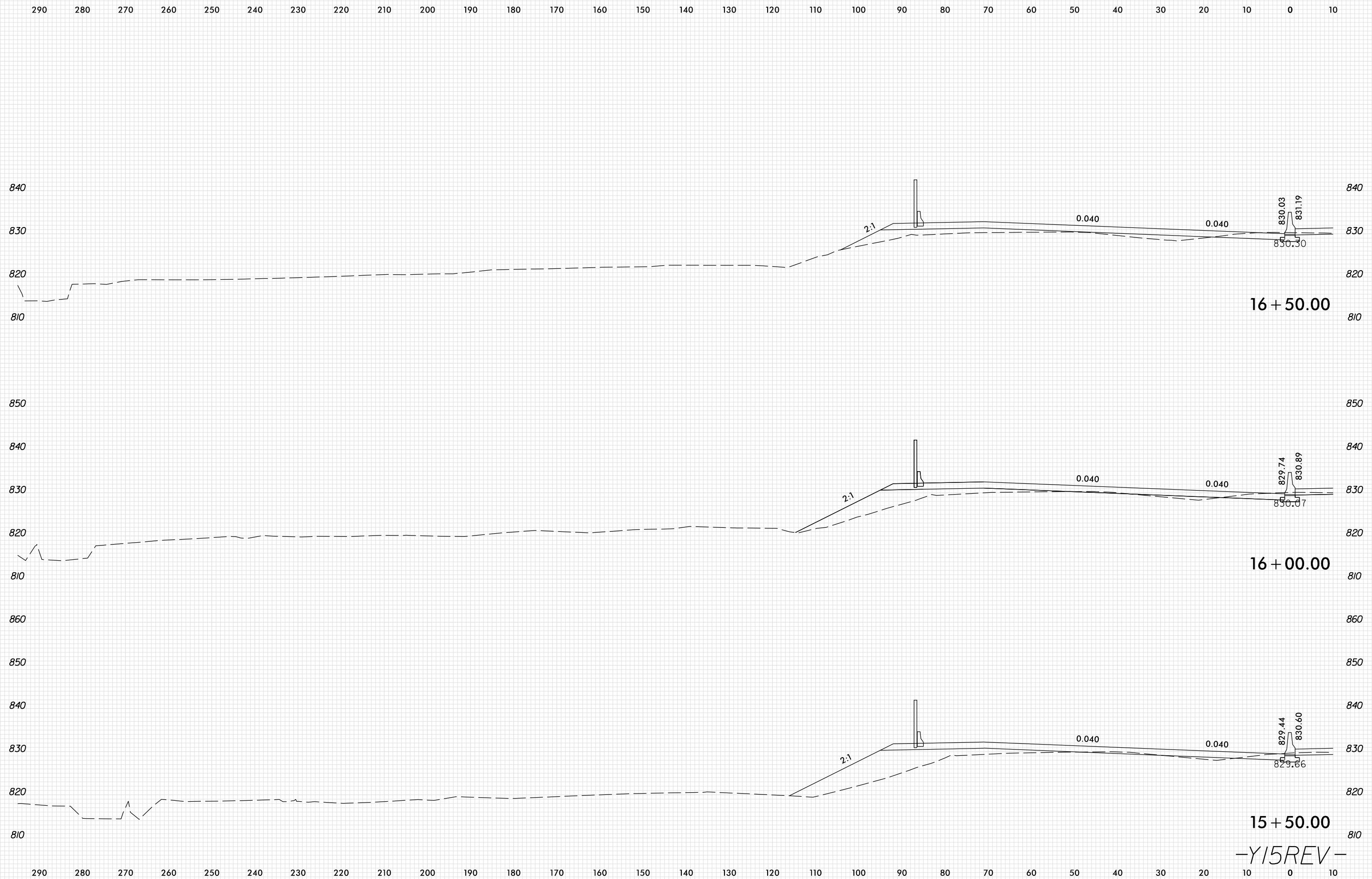

PLOT DRIVER: NCD01_pdf_color_eng_100.plt
 USER: SPEREIRA
 DATE: 6/10/2021
 TIME: 2:22:42 PM
 FILE: \

-Y15REV-

8/23/99

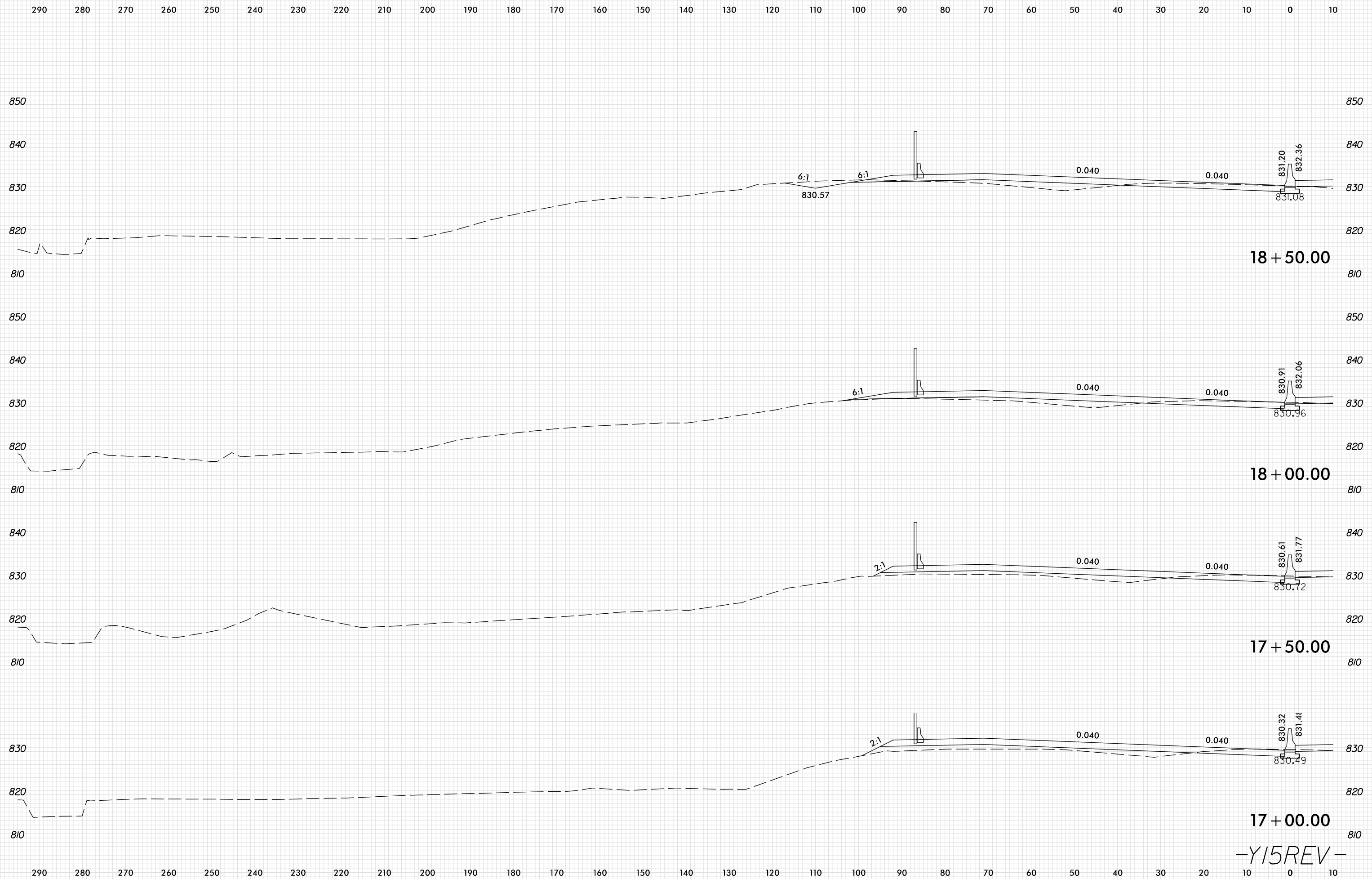

PLOT DRIVER: NCD01_pdf_color_eng_100.plt
 USER: SPEREIRA
 DATE: 6/10/2021
 TIME: 2:22:42 PM
 FILE: \

-Y15REV-

8/23/99

0 5 10	PROJ. REFERENCE NO.	SHEET NO.
	U-2579AB	X-275

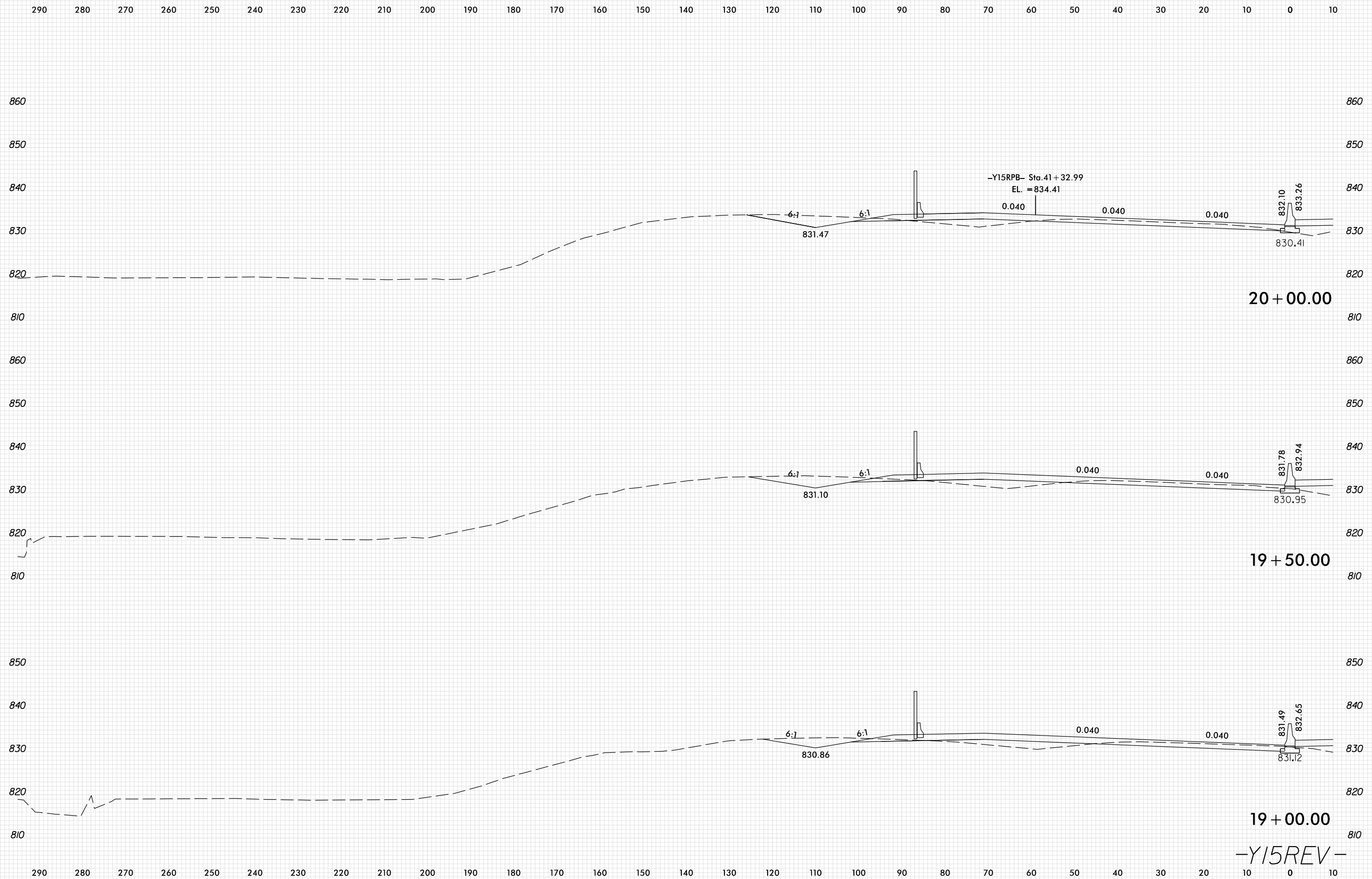

-Y15REV-

PLOT DRIVER: NCD01.pdf_color_eng_100.plt
 USER: SPEREIRA
 DATE: 6/10/2021
 TIME: 2:22:43 PM
 FILE: \

8/23/99

0 5 10	PROJ. REFERENCE NO.	SHEET NO.
	U-2579AB	X-276

290 280 270 260 250 240 230 220 210 200 190 180 170 160 150 140 130 120 110 100 90 80 70 60 50 40 30 20 10 0 10

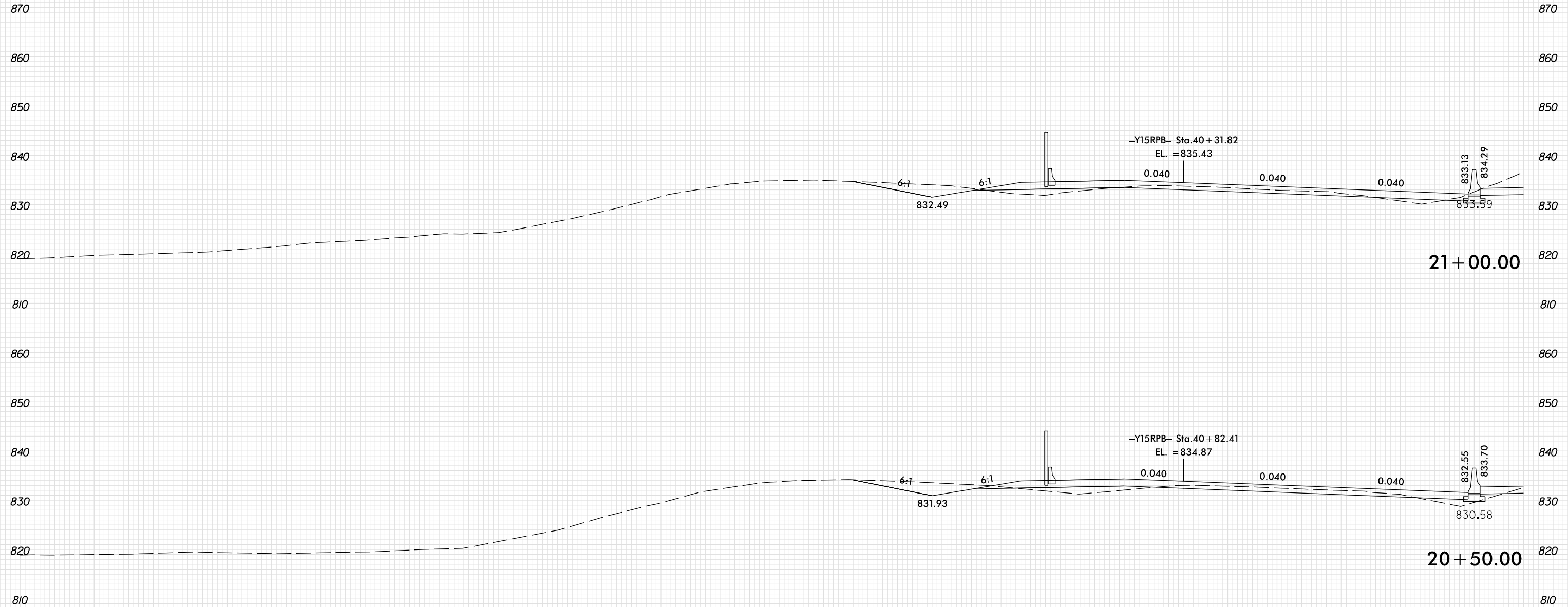

-Y15REV-

PLOT DRIVER: NCDOT_pdf_color_eng_100.plt
 USER: SPEREIRA
 DATE: 6/10/2021
 TIME: 2:22:44 PM
 FILE: \

8/23/99

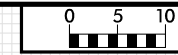

PROJ. REFERENCE NO.	SHEET NO.
U-2579AB	X-277

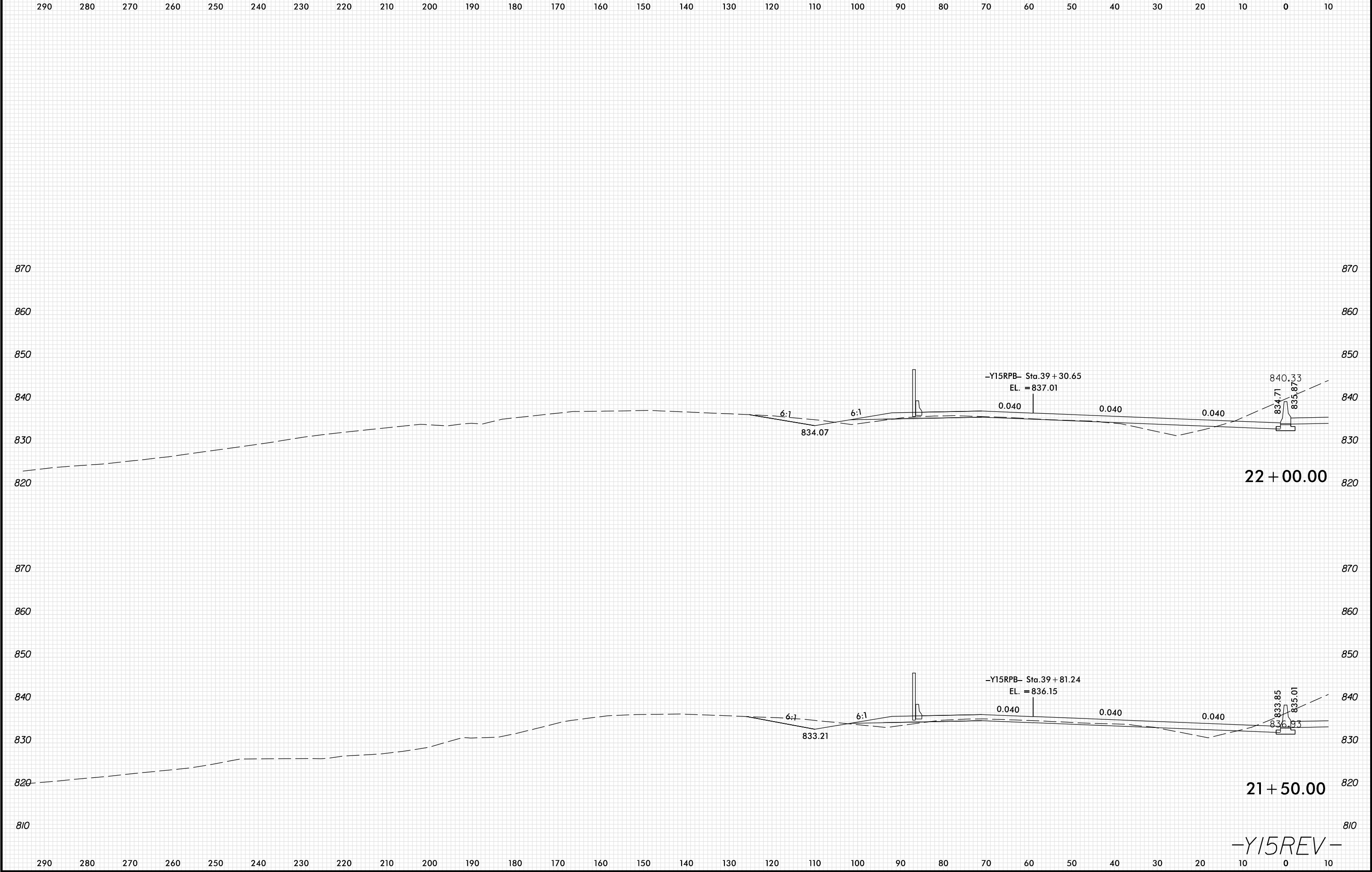

-Y15REV-

PLOT DRIVER: NCDOT_pdf_color_eng_100.plt
 USER: SPEREIRA
 DATE: 6/10/2021
 TIME: 2:22:44 PM
 FILE: \

8/23/99

0 5 10	PROJ. REFERENCE NO.	SHEET NO.
	U-2579AB	X-278

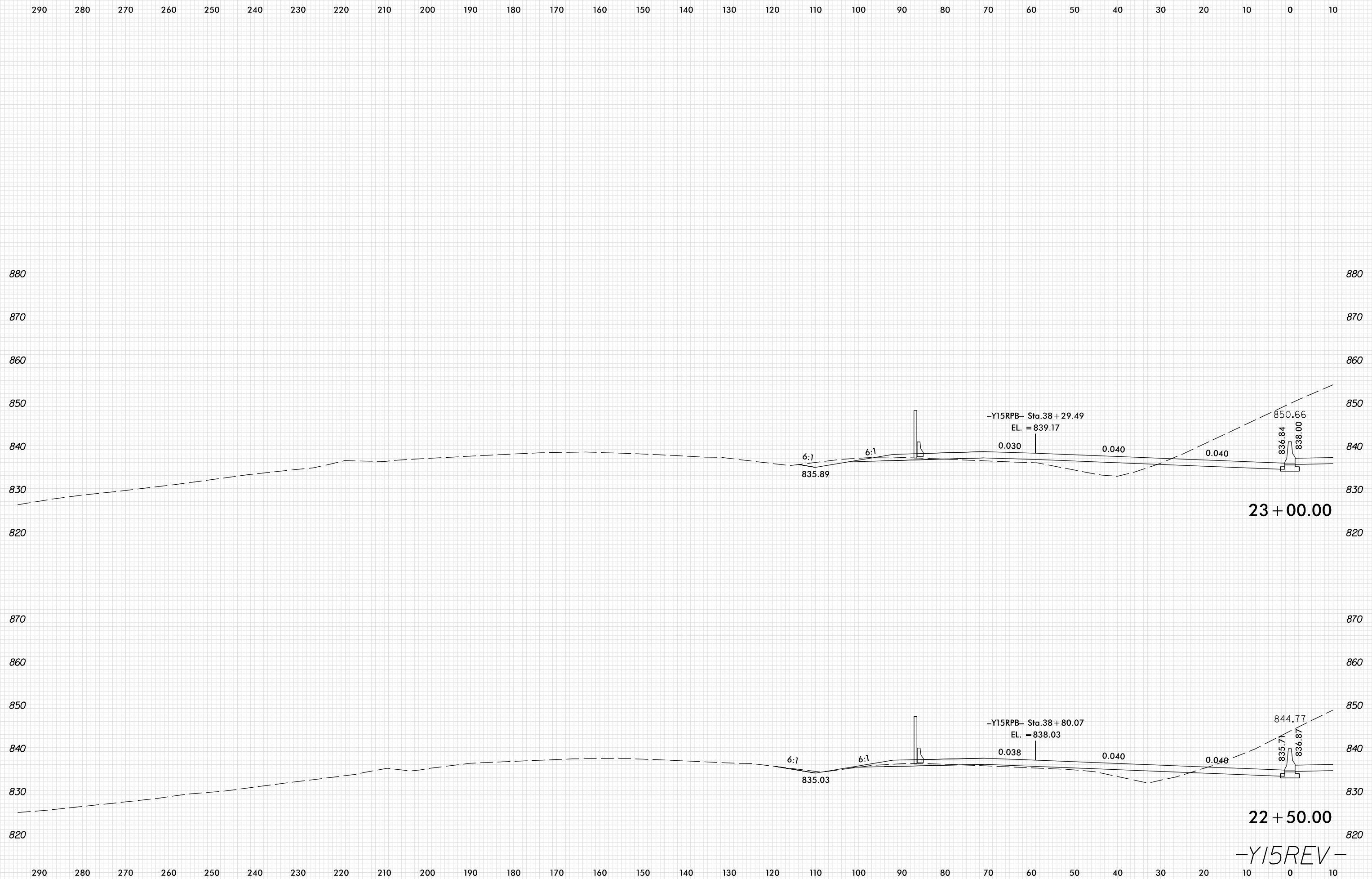

PLOT DRIVER: NCDOT_pdf_color_eng_100.plt
 USER: SPEREIRA
 DATE: 6/10/2021
 TIME: 2:22:45 PM
 FILE: \

-Y15REV-

8/23/99

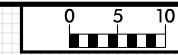

PROJ. REFERENCE NO.	SHEET NO.
U-2579AB	X-279

290 280 270 260 250 240 230 220 210 200 190 180 170 160 150 140 130 120 110 100 90 80 70 60 50 40 30 20 10 0 10

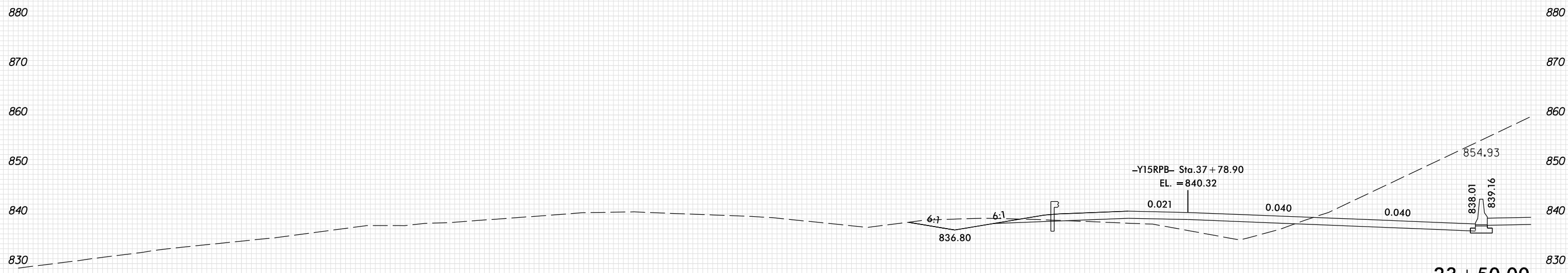
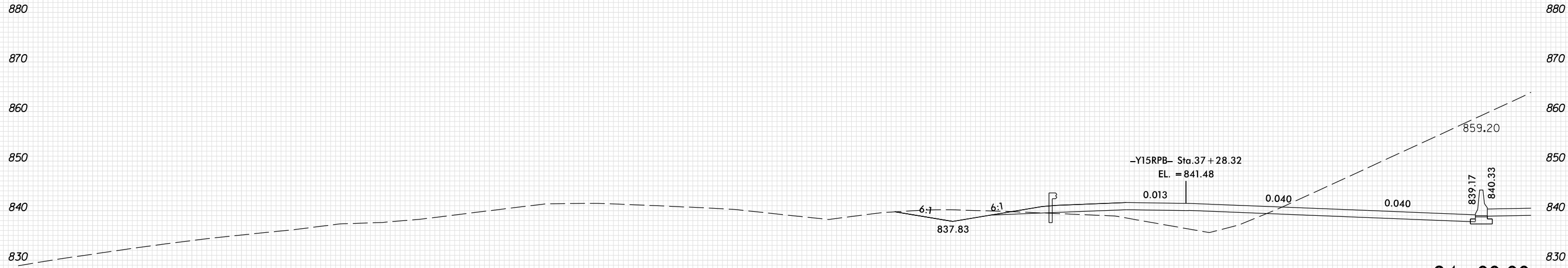

-Y15REV-

290 280 270 260 250 240 230 220 210 200 190 180 170 160 150 140 130 120 110 100 90 80 70 60 50 40 30 20 10 0 10

PLOT DRIVER: NCD01_.pdf_color_eng_100.plt
 USER: SPEREIRA
 DATE: 6/10/2021
 TIME: 2:22:46 PM
 FILE: \

8/23/99

0 5 10	PROJ. REFERENCE NO.	SHEET NO.
	U-2579AB	X-280

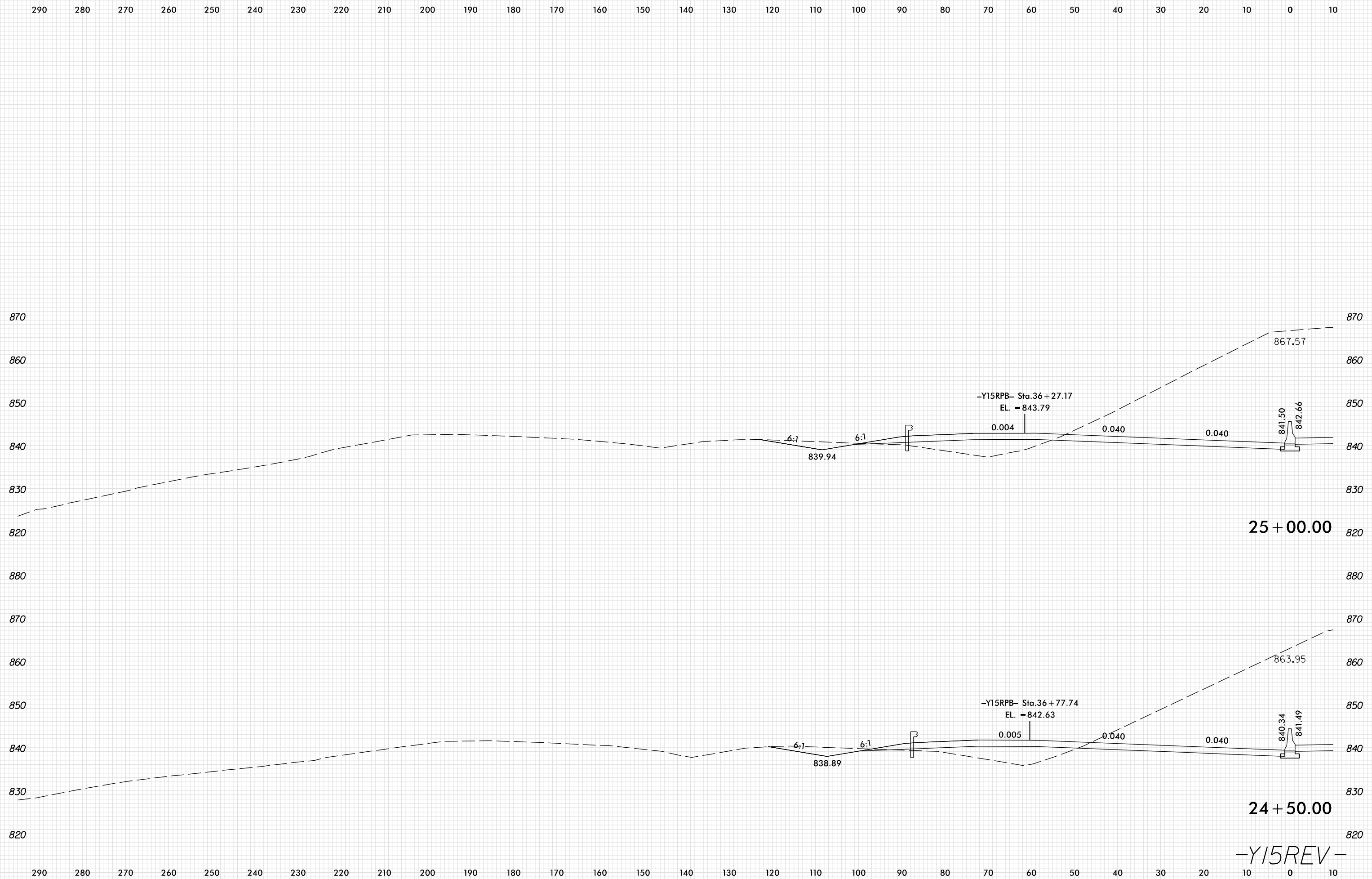

PLOT DRIVER: NCD01.pdf_color_eng_100.plt
 USER: SPEREIRA
 DATE: 6/10/2021
 TIME: 2:22:46 PM
 FILE: \

-Y15REV-

8/23/99

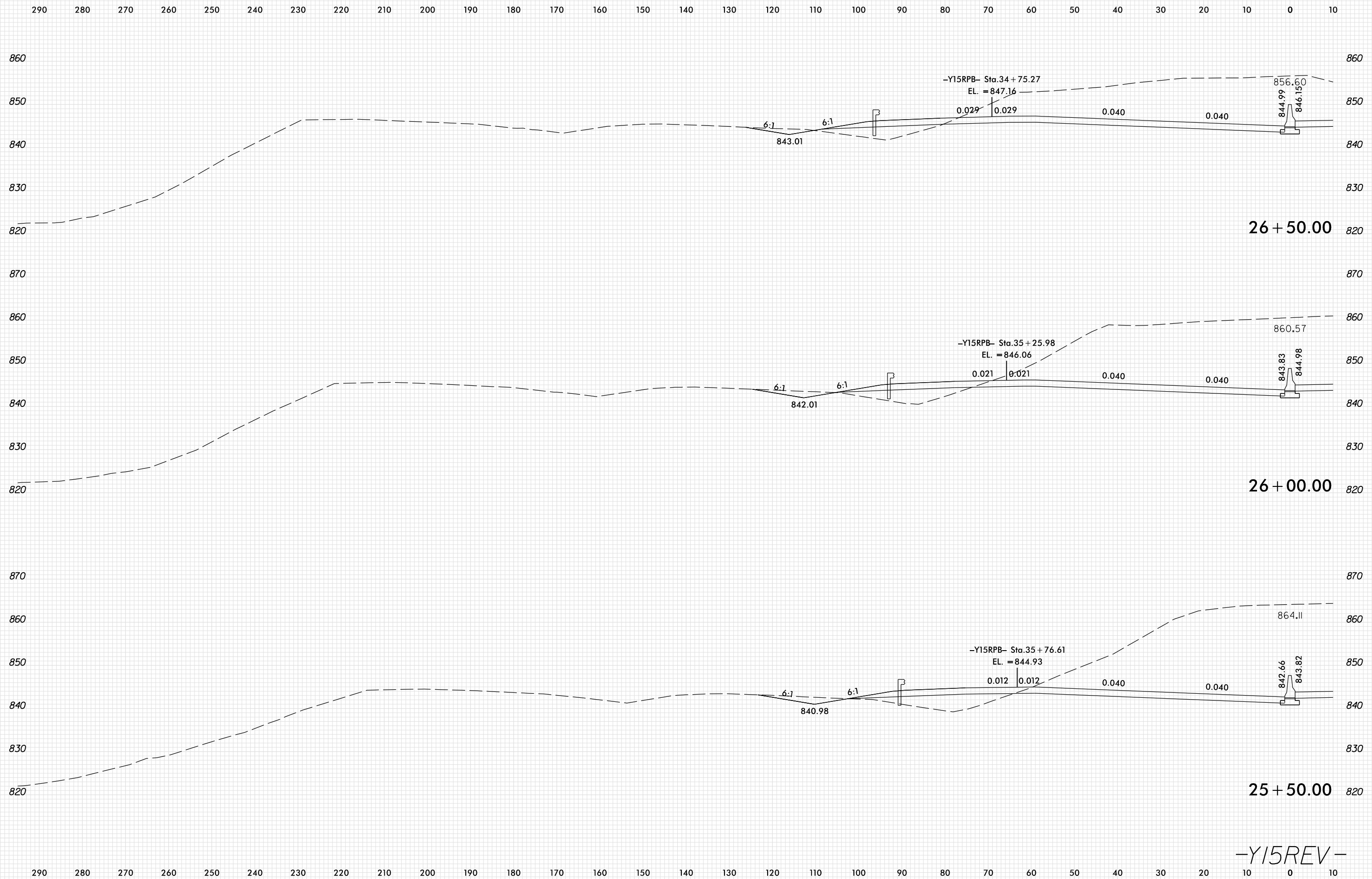

PLOT DRIVER: NCDOT_pdf_color_eng_100.plt
 USER: SPEREIRA
 DATE: 6/10/2021
 TIME: 2:22:47 PM
 FILE: \

-Y15REV-

8/23/99

290 280 270 260 250 240 230 220 210 200 190 180 170 160 150 140 130 120 110 100 90 80 70 60 50 40 30 20 10 0 10

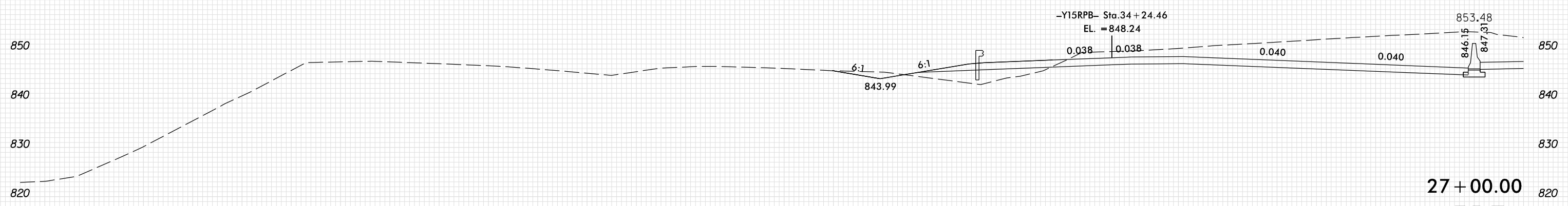
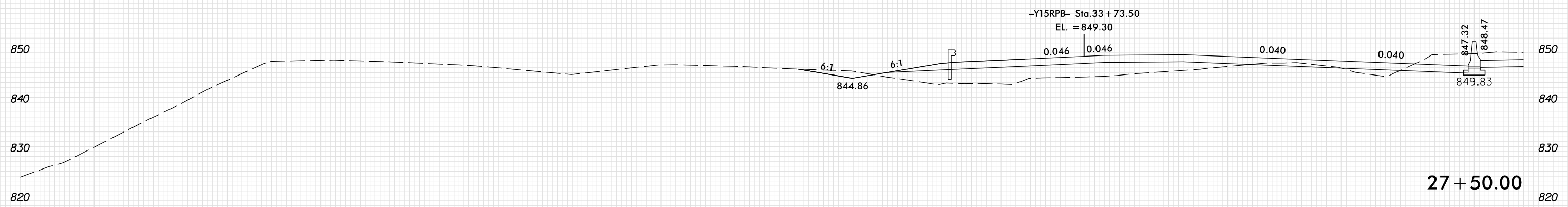
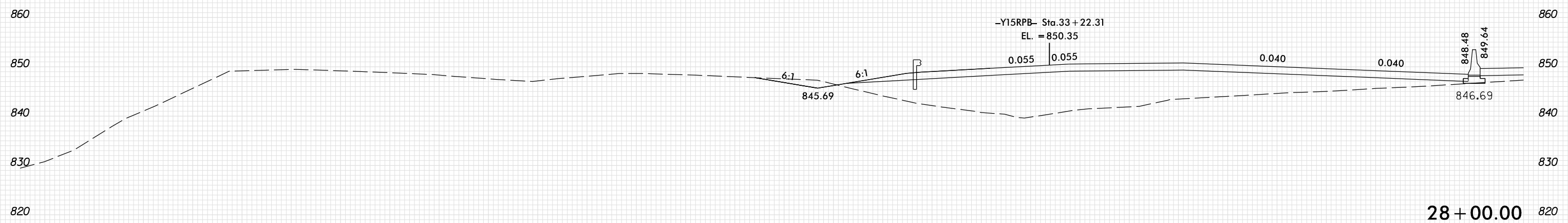

-Y15REV-

PLOT DRIVER: NCDOT_pdf_color_eng_100.plt
 USER: SPEREIRA
 DATE: 6/10/2021
 TIME: 2:22:47 PM
 FILE: \

8/23/99

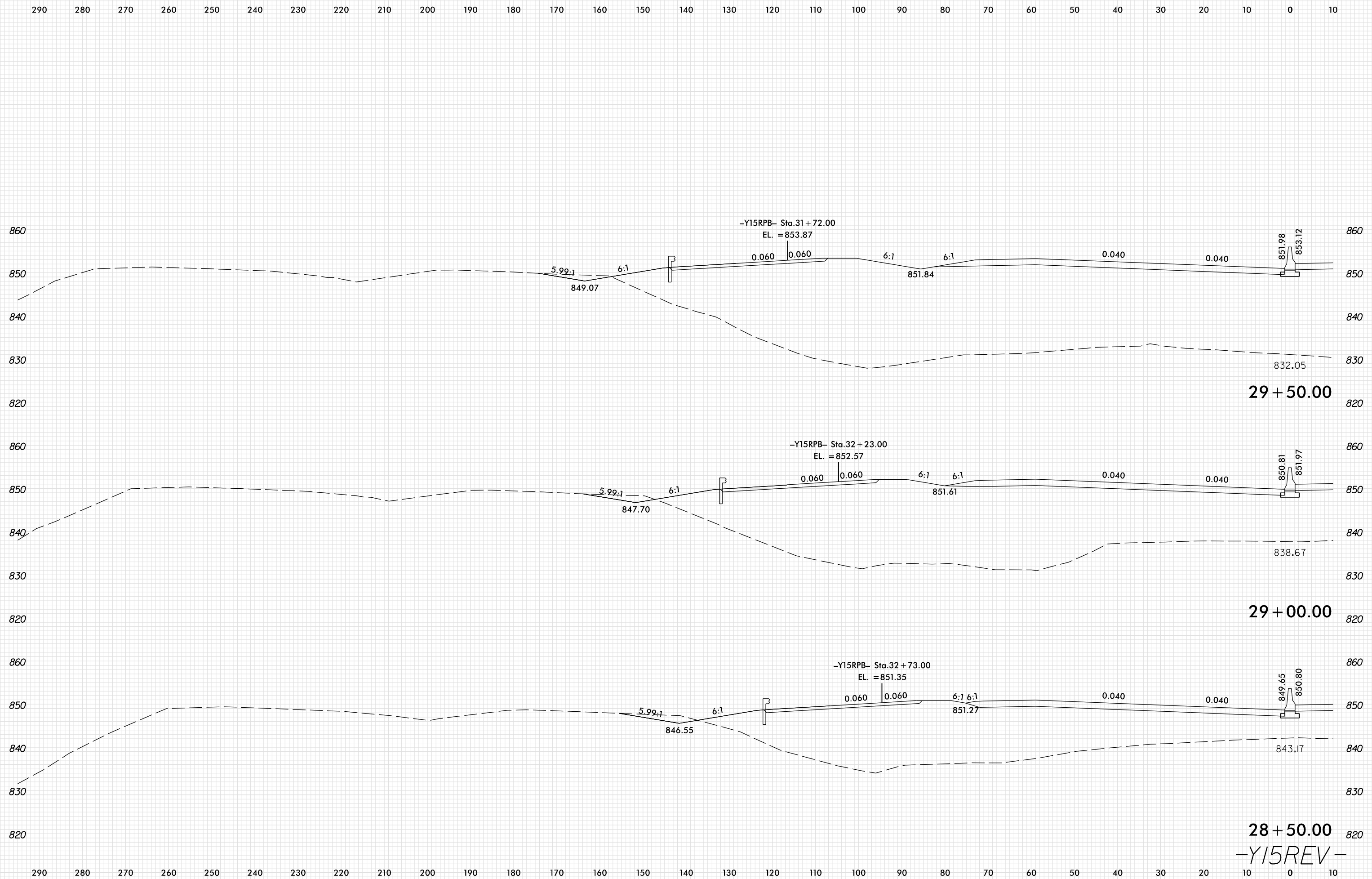

PLOT DRIVER: NCD01_pdf_color_eng_100.plt
 USER: SPEREIRA
 DATE: 6/10/2021
 TIME: 2:22:48 PM
 FILE: \

28+50.00
 -Y15REV-

8/23/99

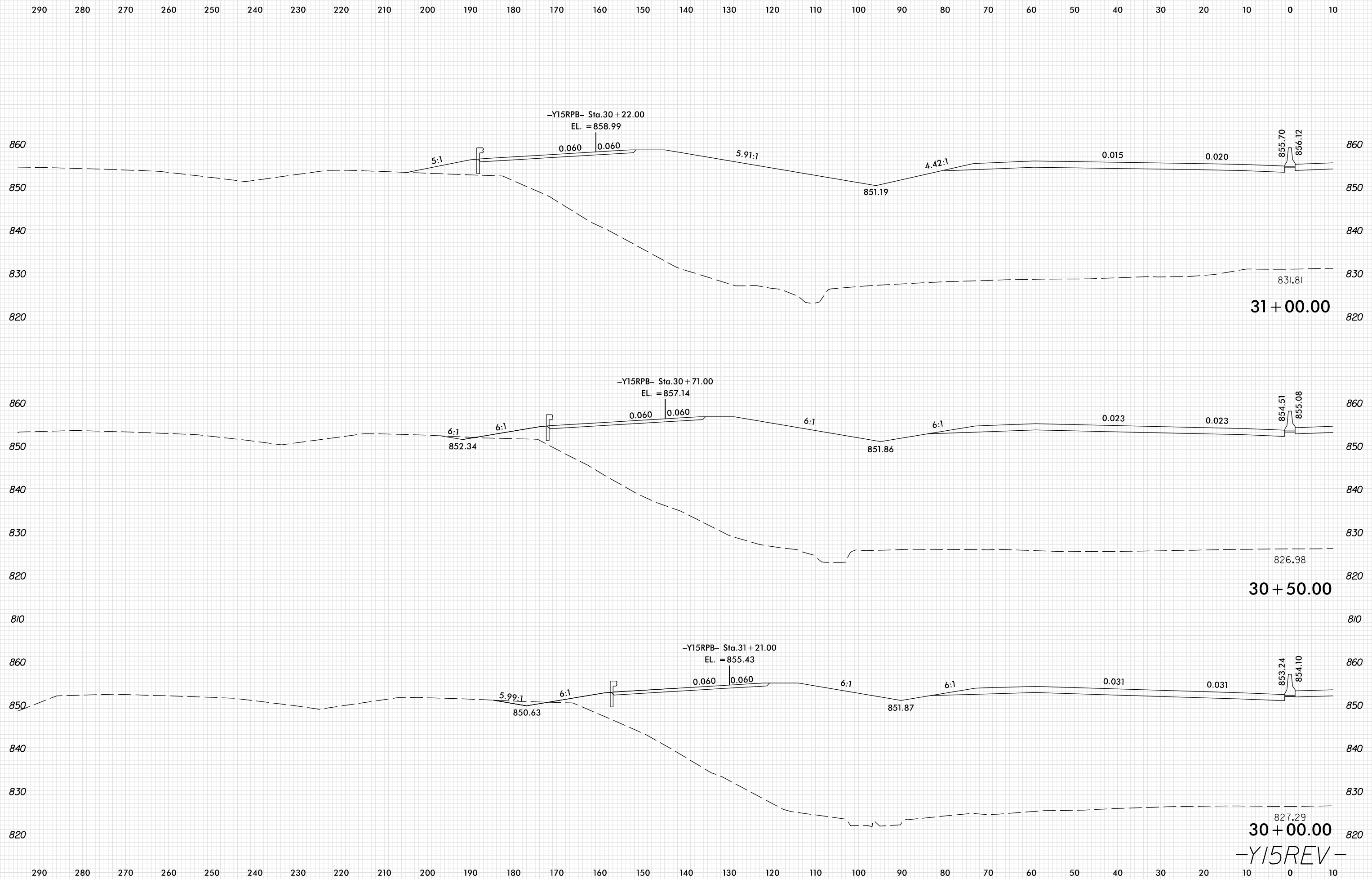

PLOT DRIVER: NCD01_.pdf_color_eng_100.plt
 USER: SPEREIRA
 DATE: 6/10/2021
 TIME: 2:22:49 PM
 FILE: \

-Y15REV-

8/23/99

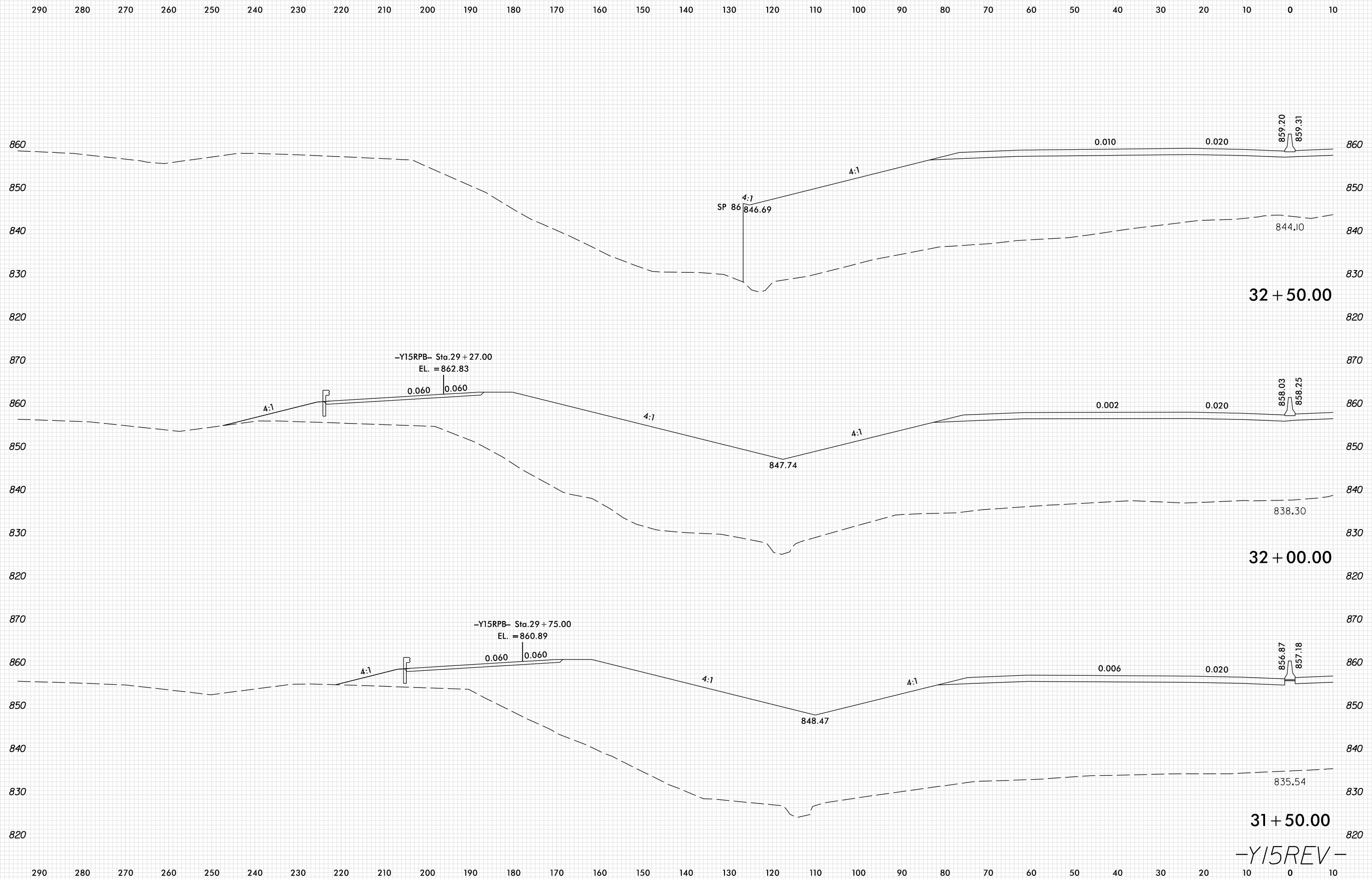

PLOT DRIVER: NCD01_pdf_color_eng_100.plt
 USER: SPEREIRA
 DATE: 6/10/2021
 TIME: 2:22:49 PM
 FILE: \

-Y15REV-

8/23/99

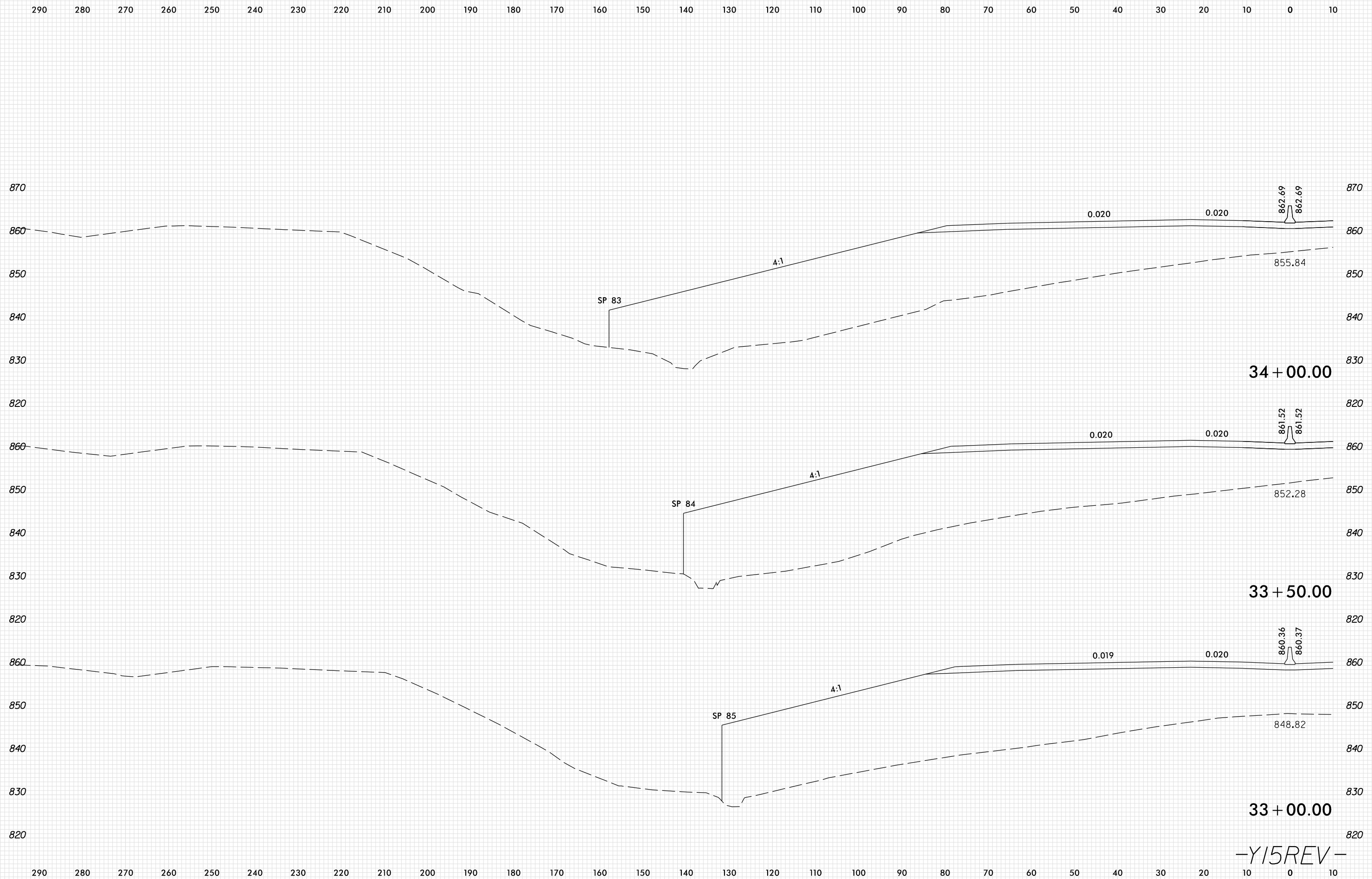

PLOT DRIVER: NCDOT_pdf_color_eng_100.plt
 USER: SPEREIRA
 DATE: 6/10/2021
 TIME: 2:22:50 PM

-Y15REV-

8/23/99

0 5 10	PROJ. REFERENCE NO.	SHEET NO.
	U-2579AB	X-287

290 280 270 260 250 240 230 220 210 200 190 180 170 160 150 140 130 120 110 100 90 80 70 60 50 40 30 20 10 0 10

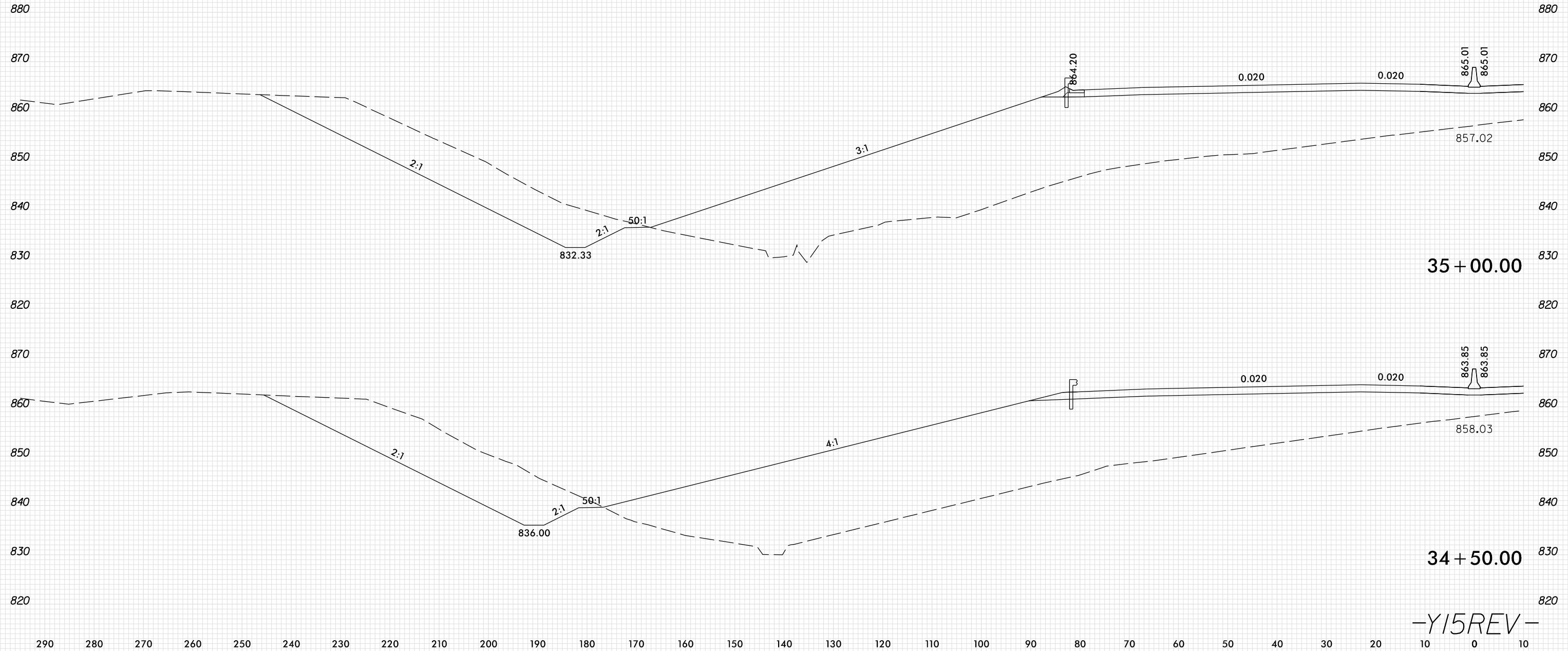

PLOT DRIVER: NCDOT_pdf_color_eng_100.plt
 USER: SPEREIRA
 DATE: 6/10/2021
 TIME: 2:22:51 PM
 FILE: \

-Y15REV-

8/23/99

0 5 10	PROJ. REFERENCE NO.	SHEET NO.
	U-2579AB	X-288

290 280 270 260 250 240 230 220 210 200 190 180 170 160 150 140 130 120 110 100 90 80 70 60 50 40 30 20 10 0 10

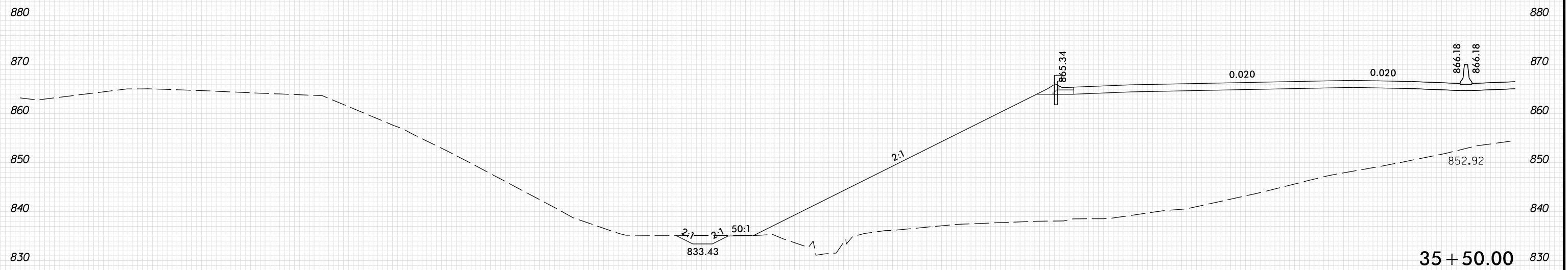
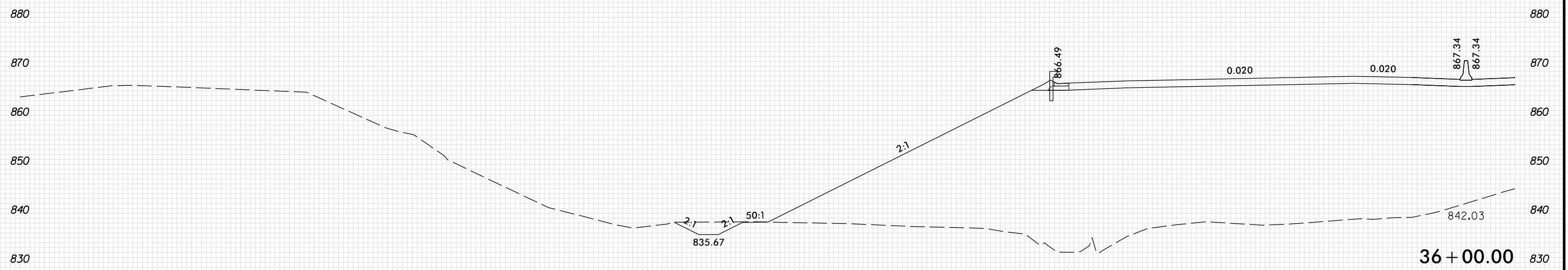

-Y15REV-

PLOT DRIVER: NCDOT_pdf_color_eng_100.plt
 USER: SPEREIRA
 DATE: 6/10/2021
 TIME: 2:22:51 PM
 FILE: \

8/23/99

0 5 10	PROJ. REFERENCE NO.	SHEET NO.
	U-2579AB	X-289

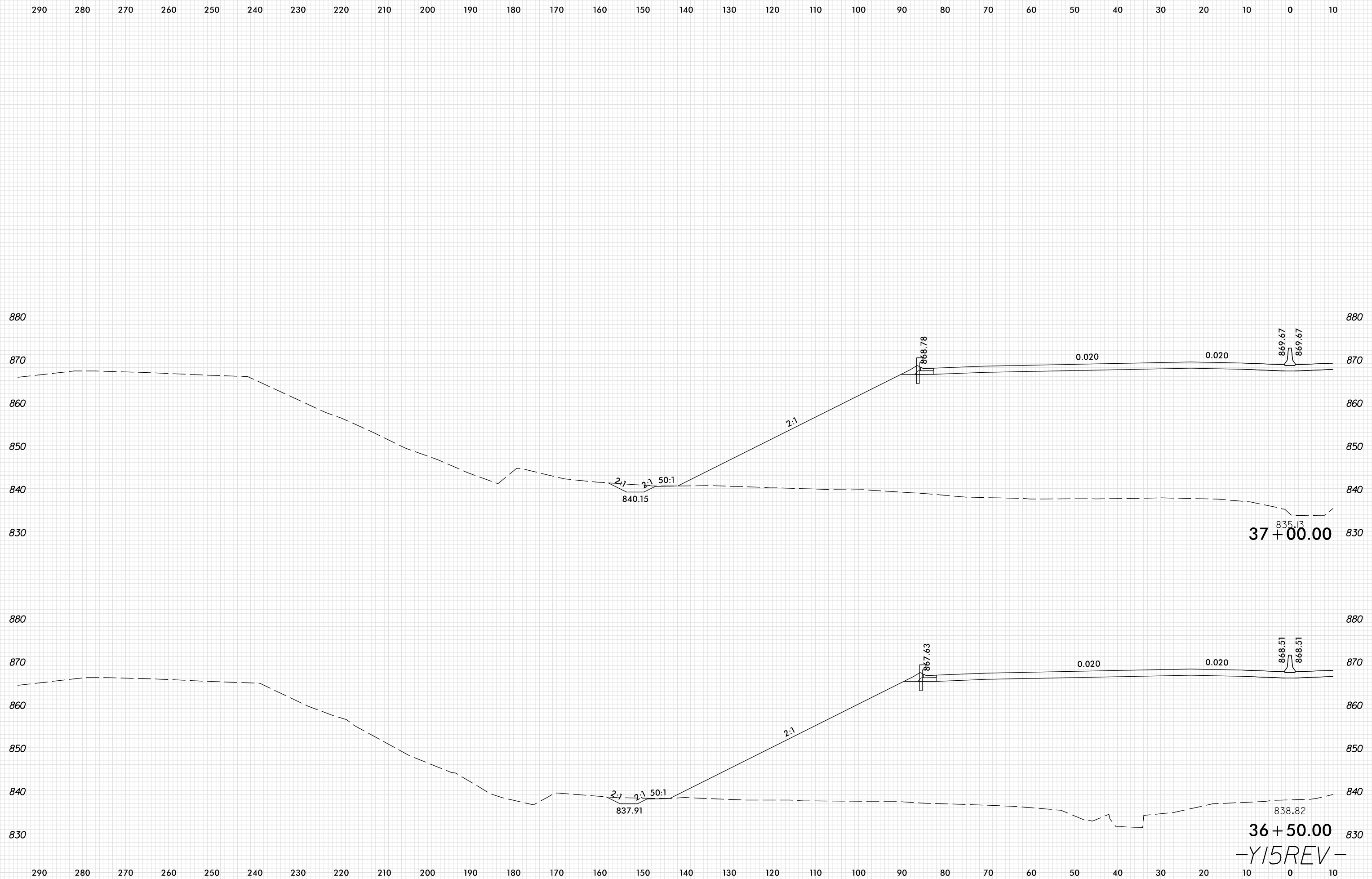

PLOT DRIVER: NCDOT_pdf_color_eng_100.plt
 USER: SPEREIRA
 DATE: 6/10/2021
 TIME: 2:22:52 PM
 FILE: \

37+00.00
 36+50.00
 -Y15REV-

8/23/99

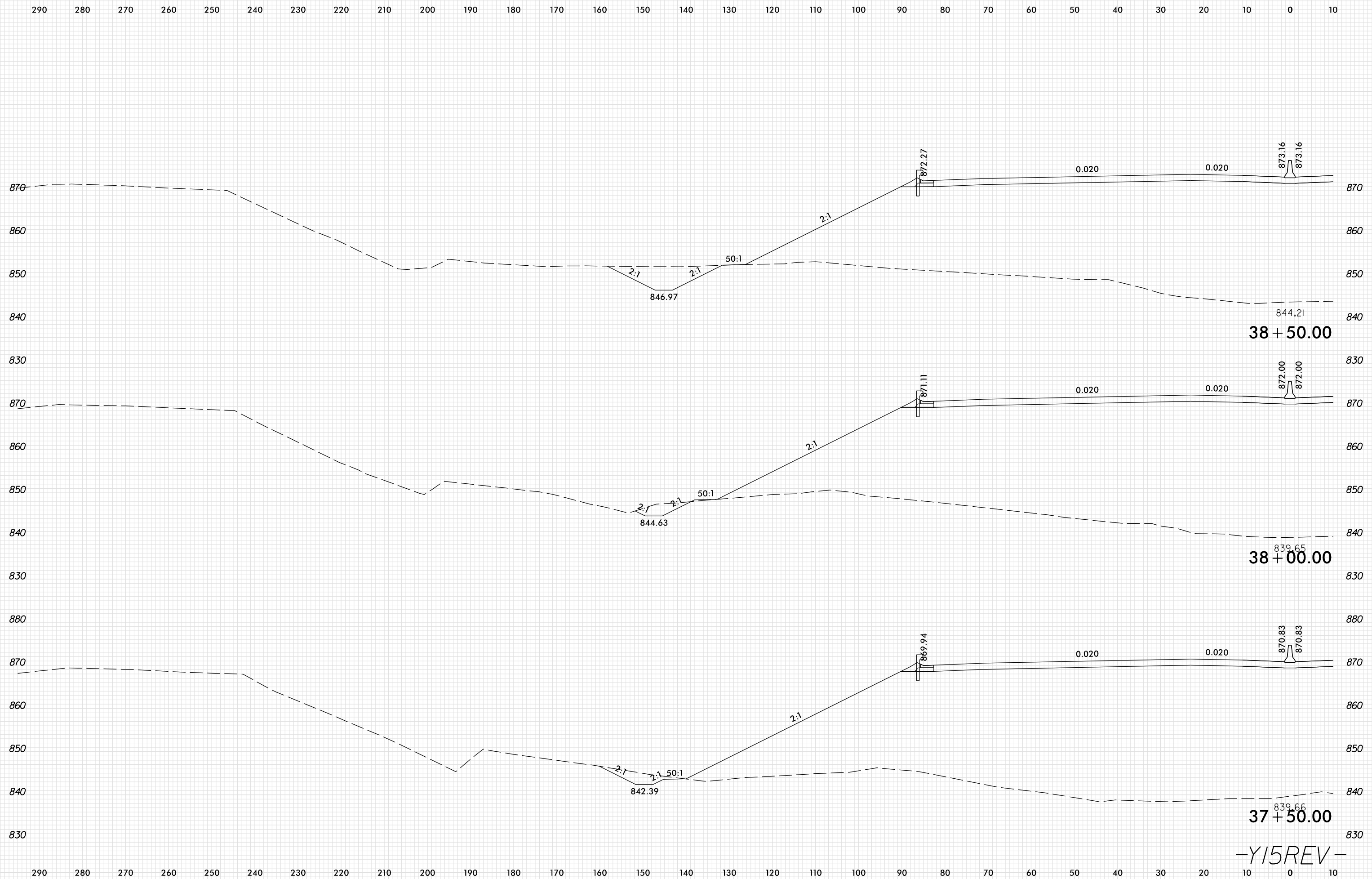

PLOT DRIVER: NCD01_color_eng_100.plt
 USER: SPEREIRA
 DATE: 6/10/2021
 TIME: 2:22:53 PM
 FILE: \

-Y15REV-

8/23/99

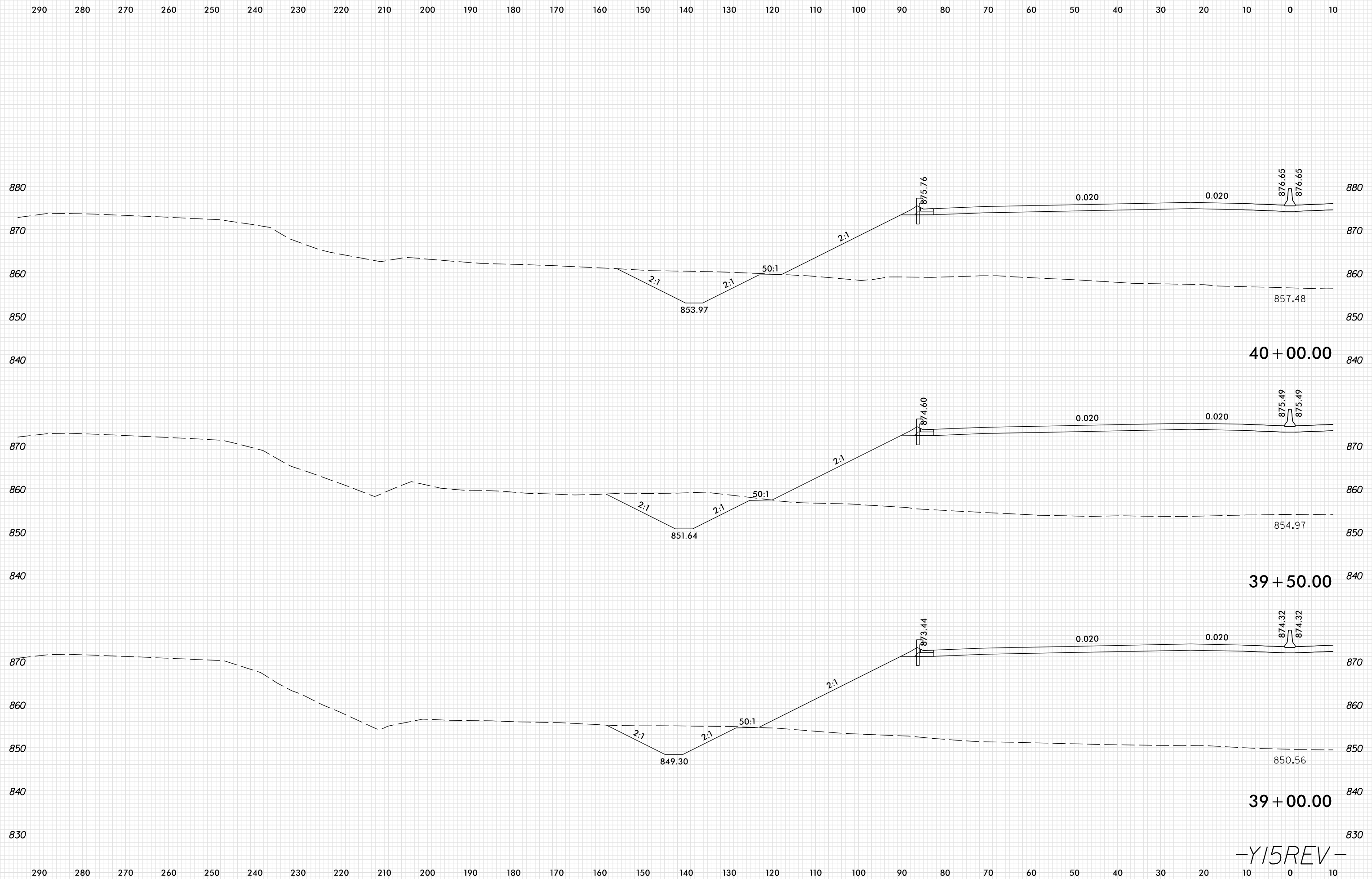

PLOT DRIVER: NCD01_pdf_color_eng_100.plt
 USER: SPEREIRA
 DATE: 6/10/2021
 TIME: 2:22:53 PM
 FILE: \

-Y15REV-

8/23/99

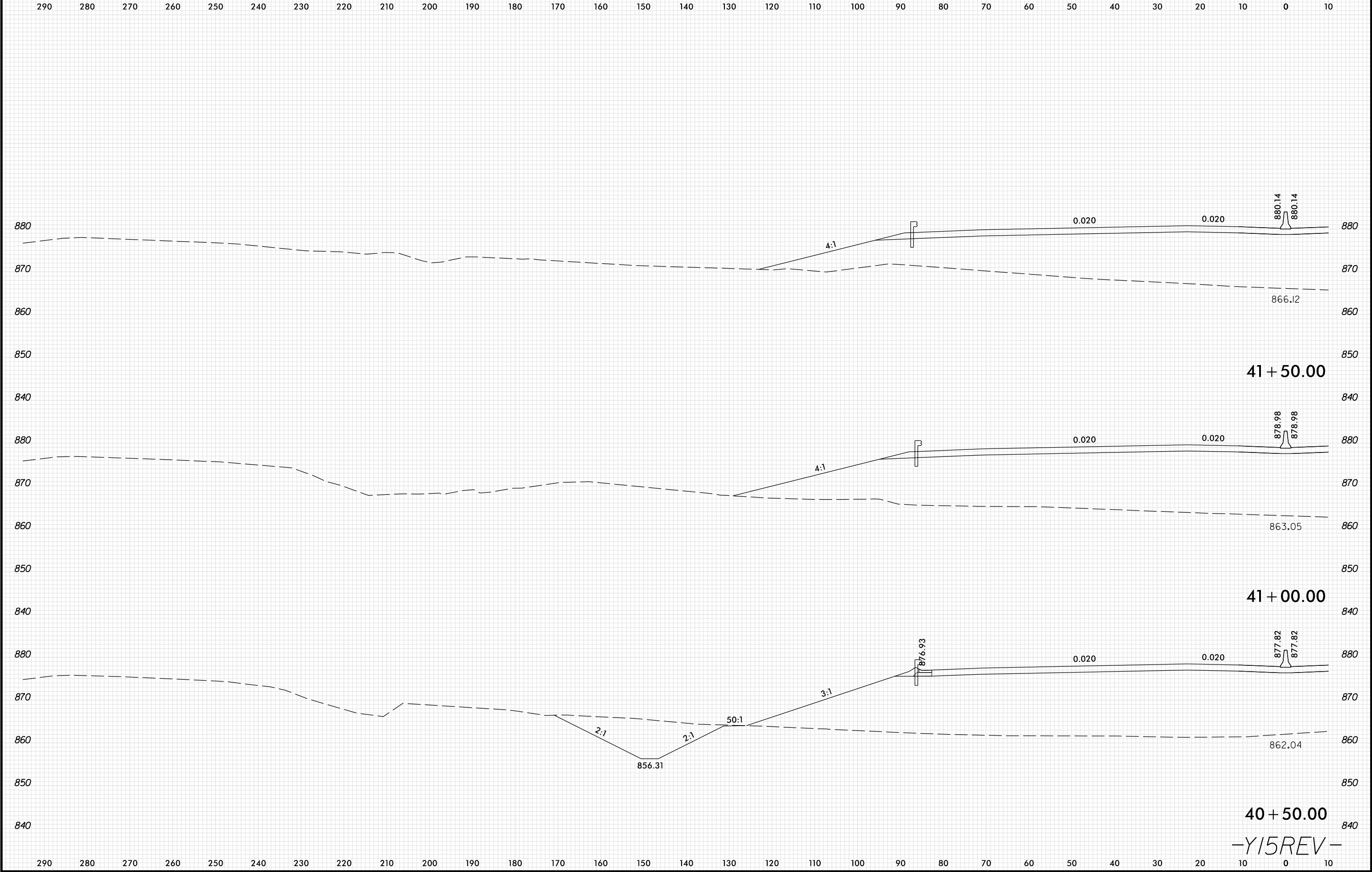

PLOT DRIVER: NCD01_pdf_color_eng_100.plt
 USER: SPEREIRA
 DATE: 6/10/2021
 TIME: 2:22:54 PM
 FILE: \

-Y15REV-

8/23/99

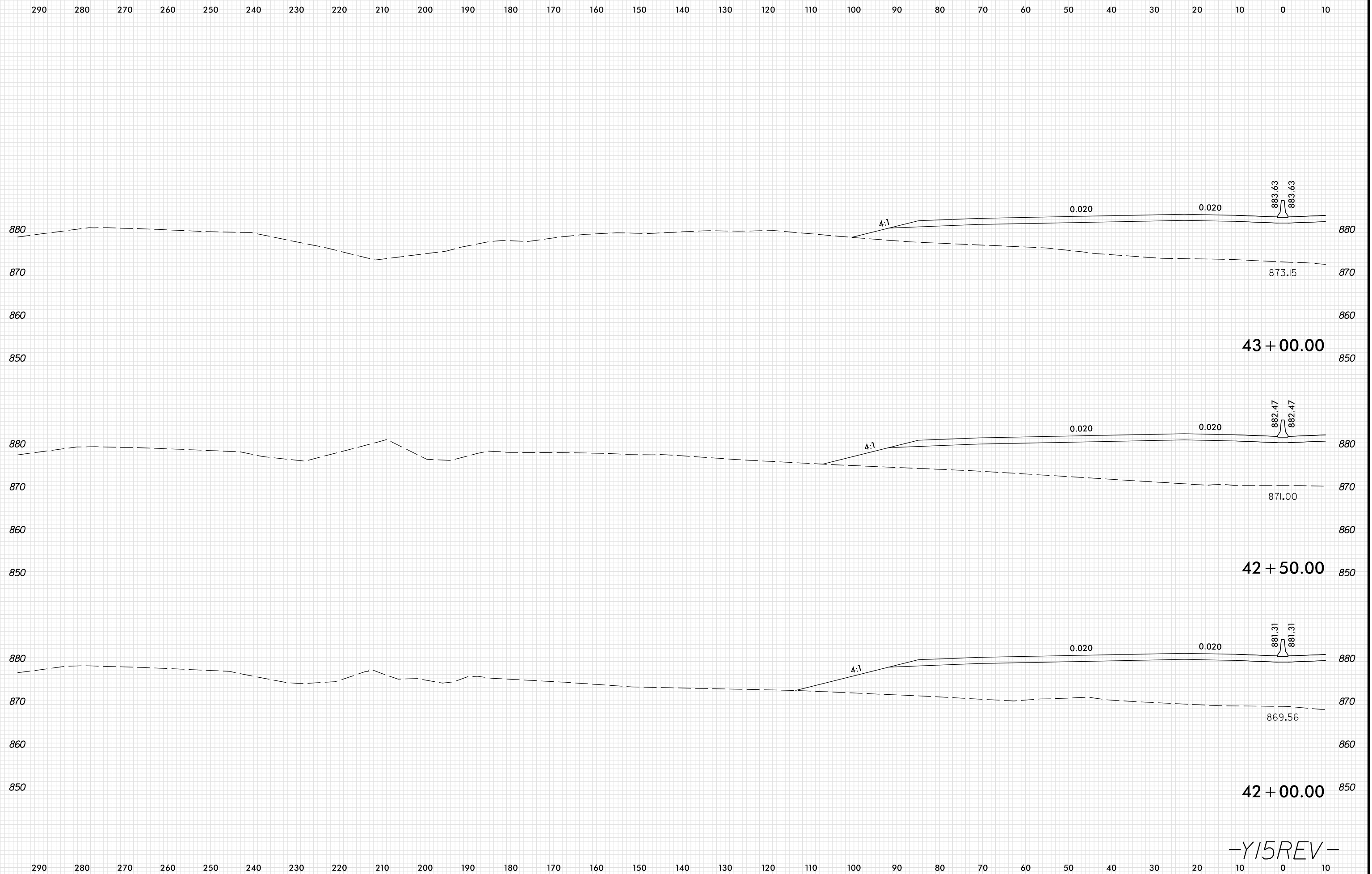

PLOT DRIVER: NCD01_pdf_color_eng_100.plt
 USER: SPEREIRA
 DATE: 6/10/2021
 TIME: 2:22:55 PM
 FILE: \

-Y15REV-

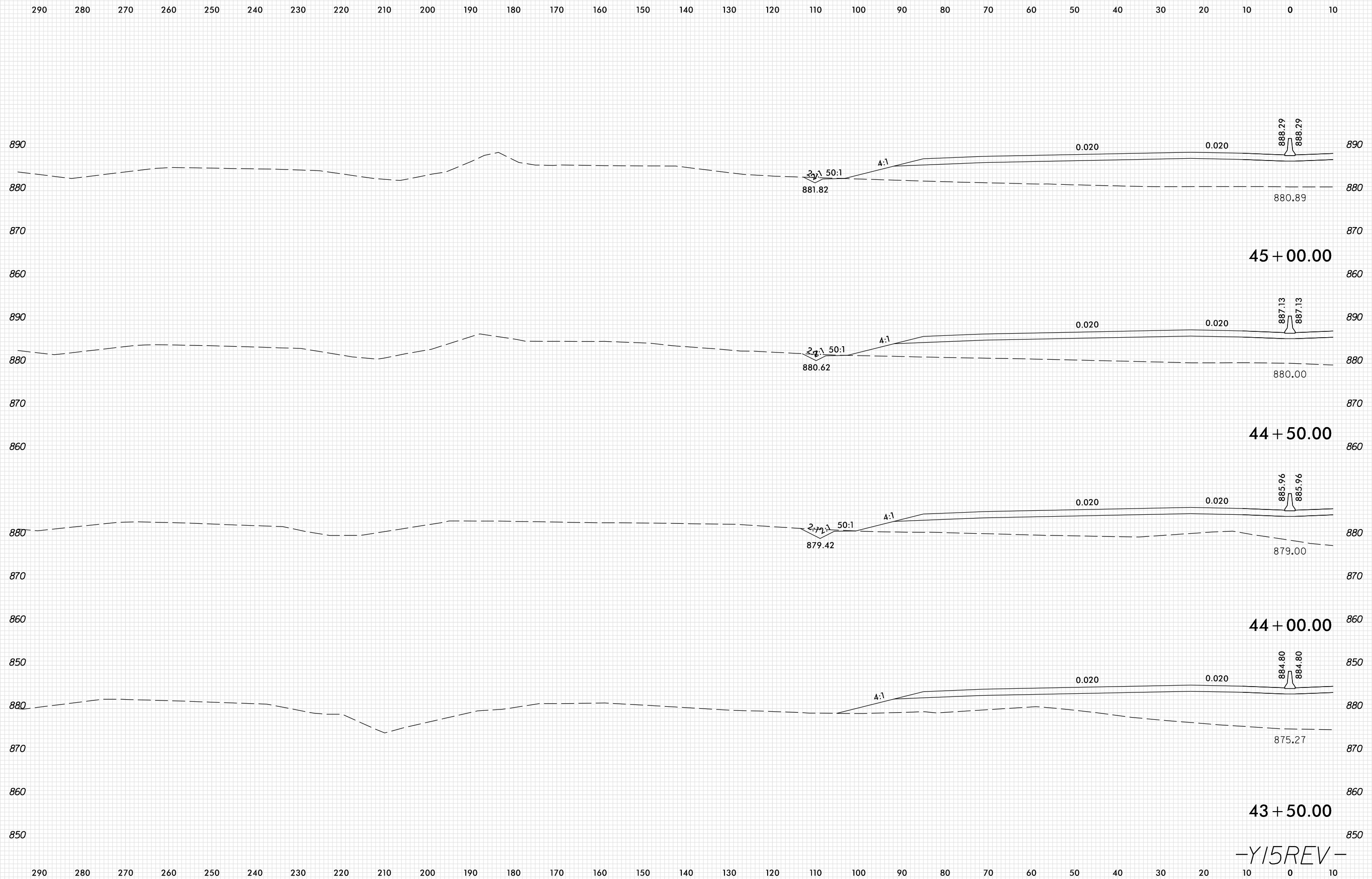

PLOT DRIVER: NCD01_pdf_color_eng_100.plt
 USER: SPEREIRA
 DATE: 6/10/2021
 TIME: 2:22:55 PM
 FILE: \

-Y15REV-

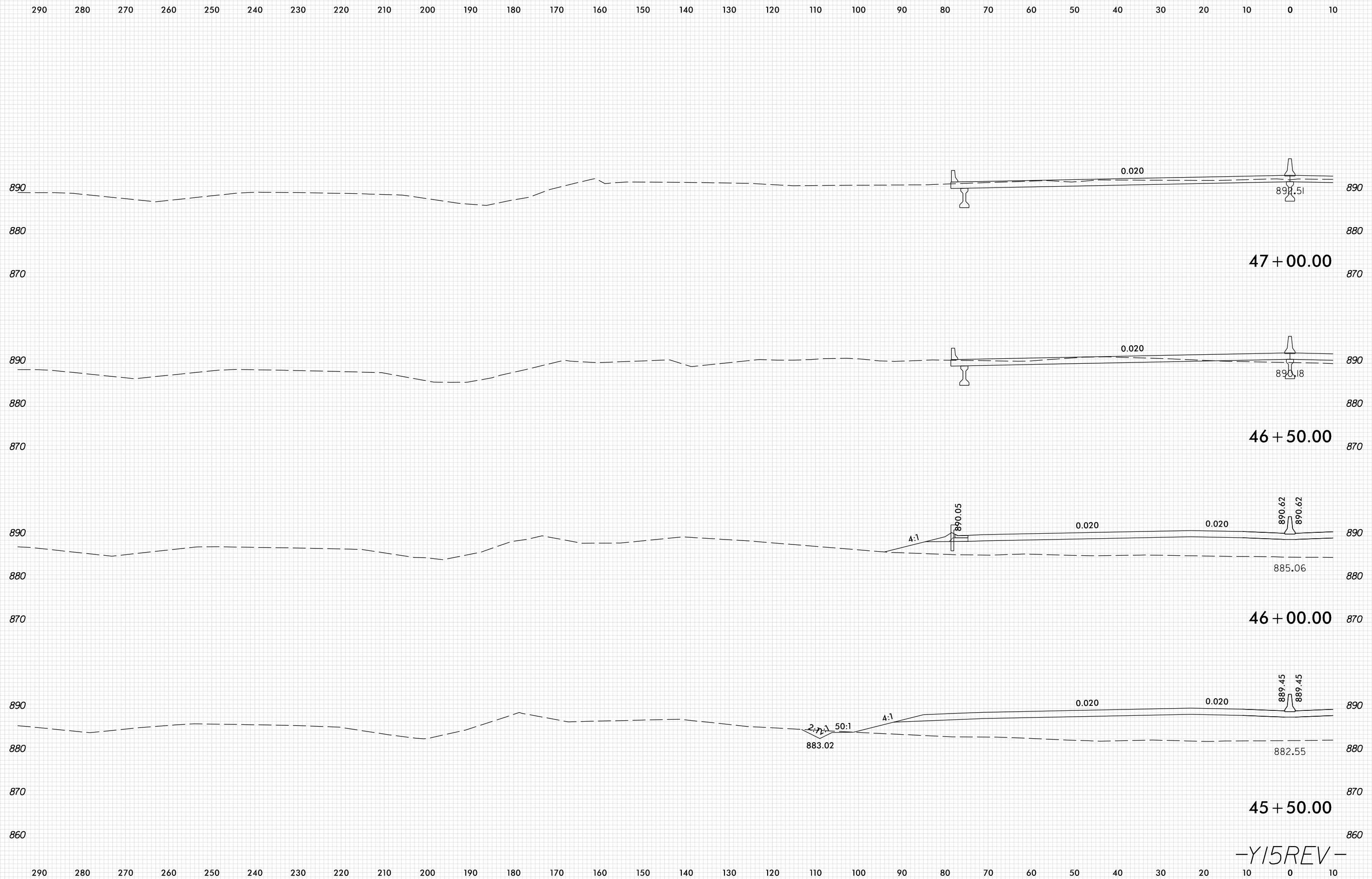

PLOT DRIVER: NCDOT_pdf_color_eng_100.plt
 USER: SPEREIRA
 DATE: 6/10/2021
 TIME: 2:22:56 PM
 FILE: \

-Y15REV-

8/23/99



PROJ. REFERENCE NO.	SHEET NO.
U-2579AB	X-296

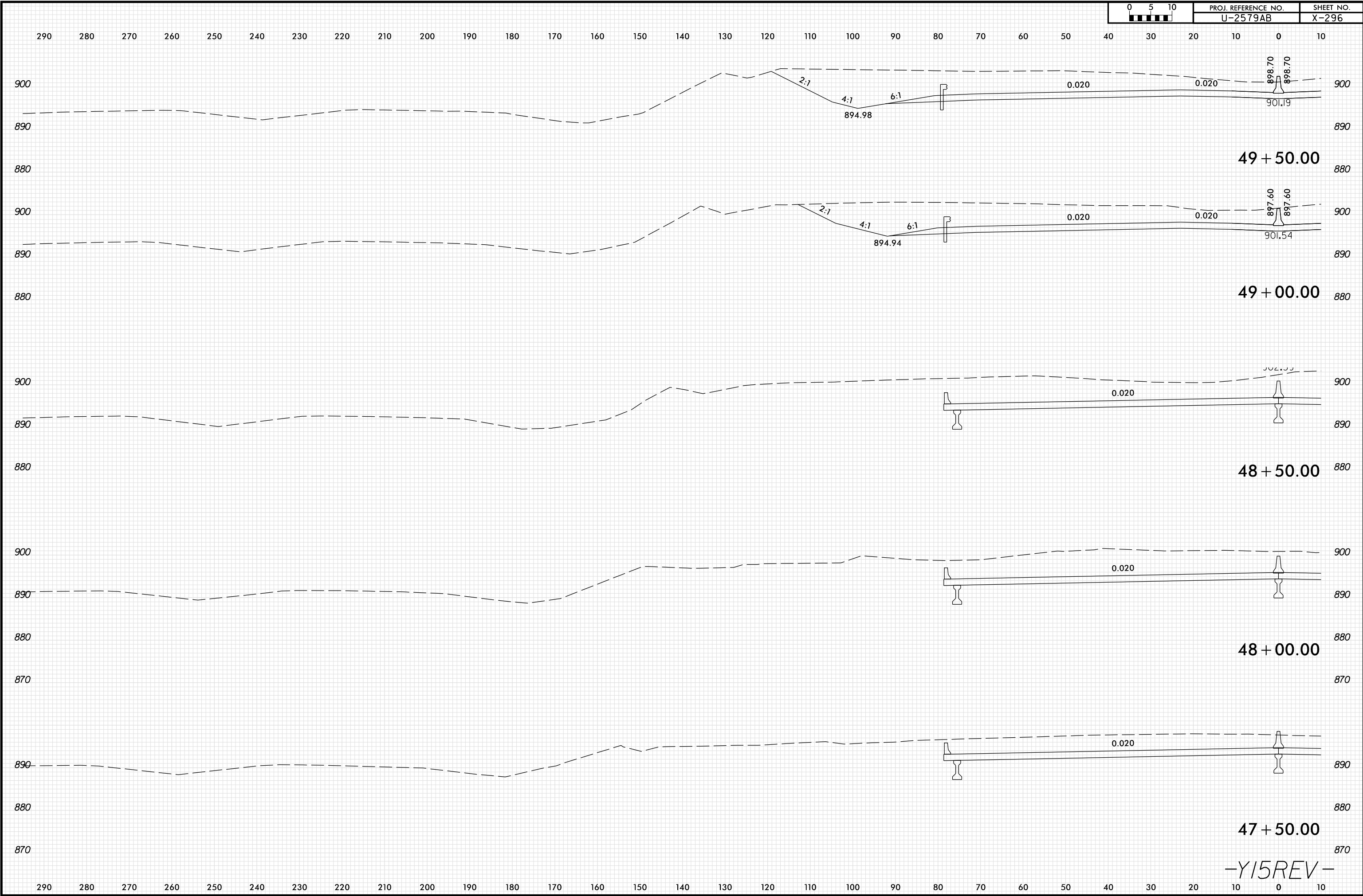

PLOT DRIVER: NCD01_pdf_color_eng_100.plt
 USER: SPEREIRA
 DATE: 6/10/2021
 TIME: 2:22:56 PM
 FILE: \

-Y15REV-

8/23/99

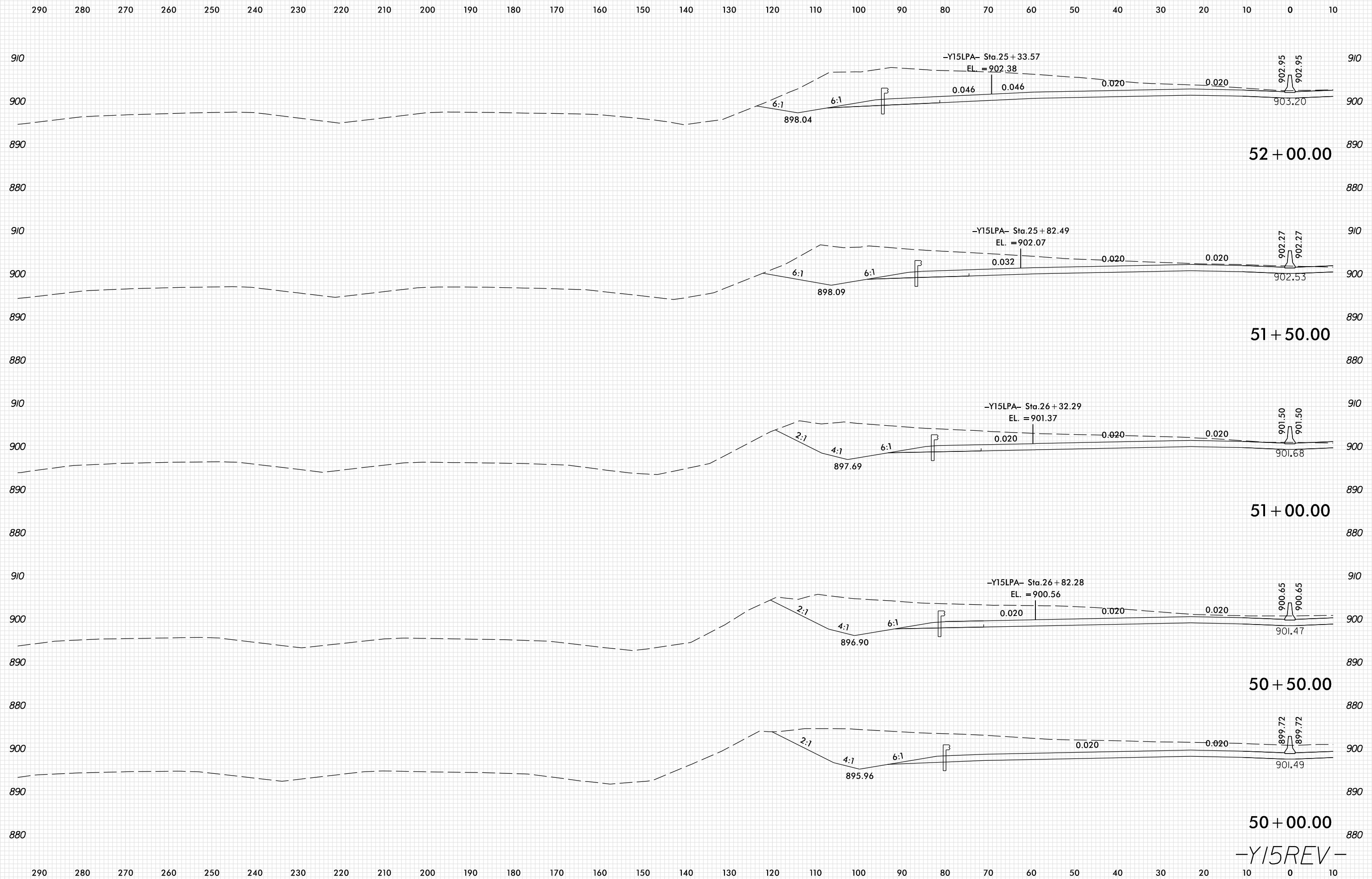

-Y15REV-

PLOT DRIVER: NCD01_pdf_color_eng_100.plt
 USER: SPEREIRA
 DATE: 6/10/2021
 TIME: 2:22:57 PM
 FILE: \

8/23/99

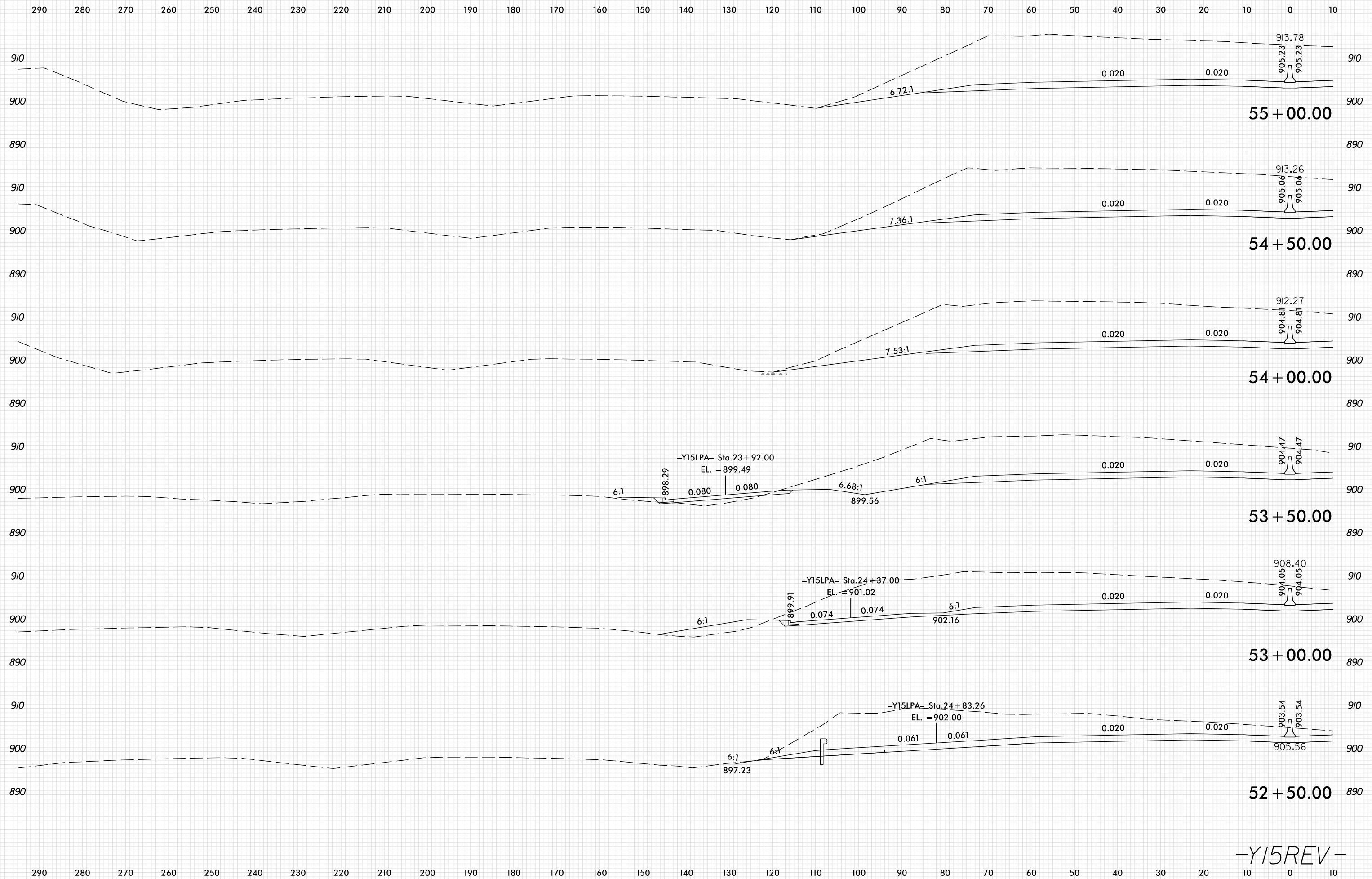

PLOT DRIVER: NCD01_pdf_color_eng_100.plt
 USER: SPEREIRA
 DATE: 6/10/2021
 TIME: 2:22:58 PM

-Y15REV-

8/23/99

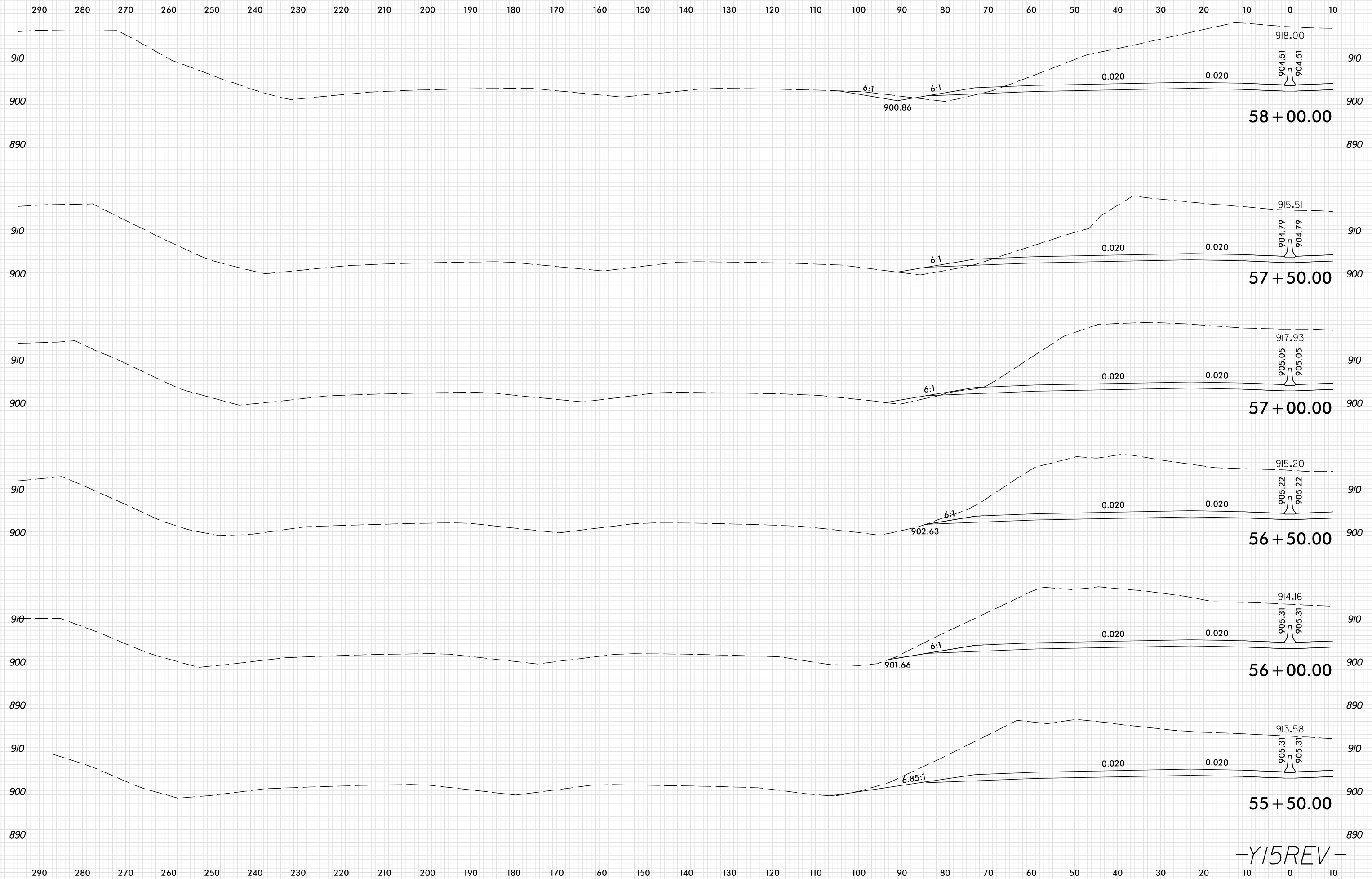

PLOT DRIVER: NCDOT_pdf_color_eng_100.plt
 USER: SPEREIRA
 DATE: 6/10/2021
 TIME: 2:22:58 PM
 FILE: \

-Y15REV-

8/23/99

0 5 10	PROJ. REFERENCE NO.	SHEET NO.
	U-2579AB	X-300

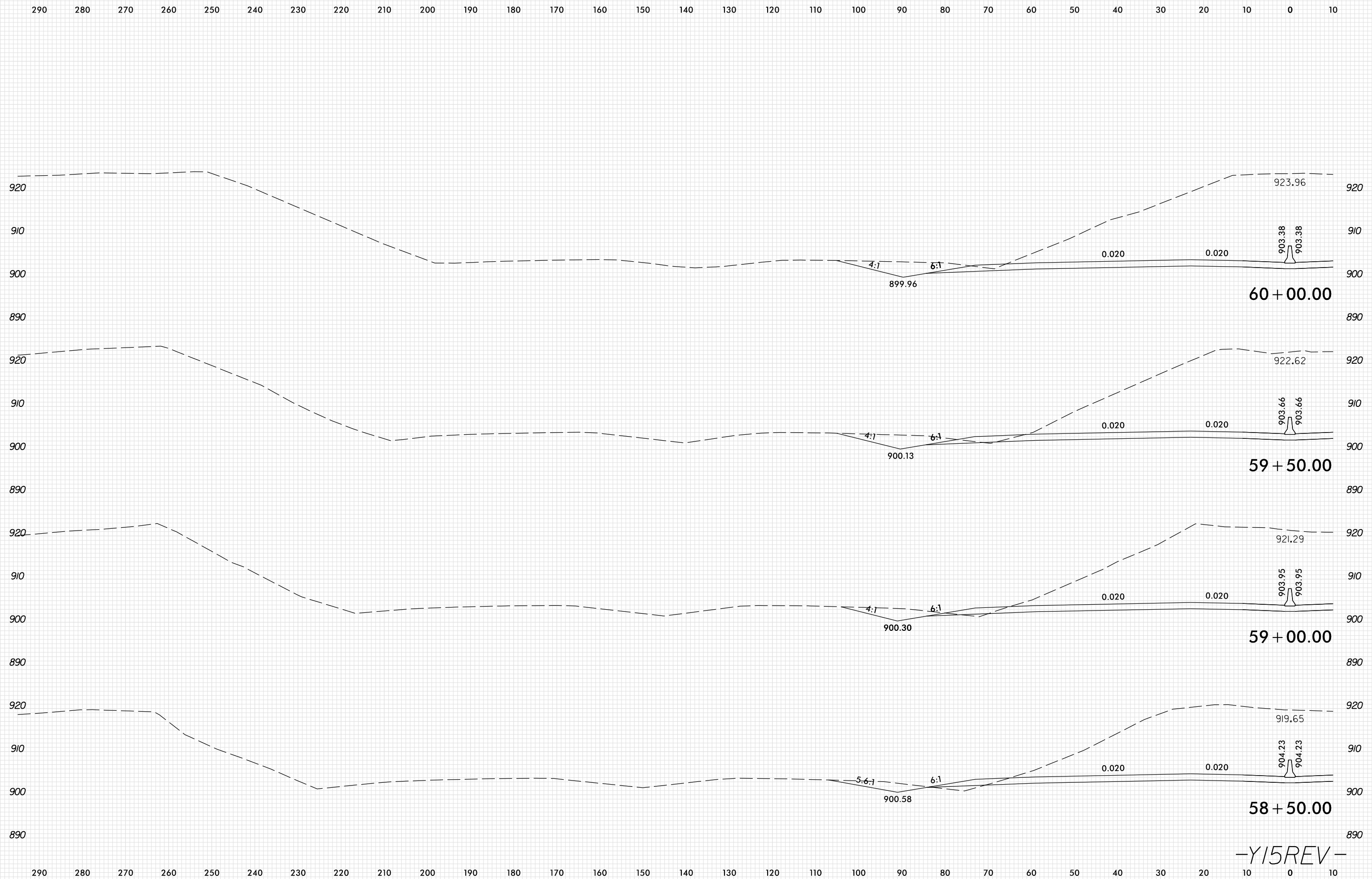

-Y15REV-

PLOT DRIVER: NCD01_pdf_color_eng_100.plt
 USER: SPEREIRA
 DATE: 6/10/2021
 TIME: 2:22:59 PM
 FILE: \

8/23/99

0 5 10	PROJ. REFERENCE NO.	SHEET NO.
	U-2579AB	X-301

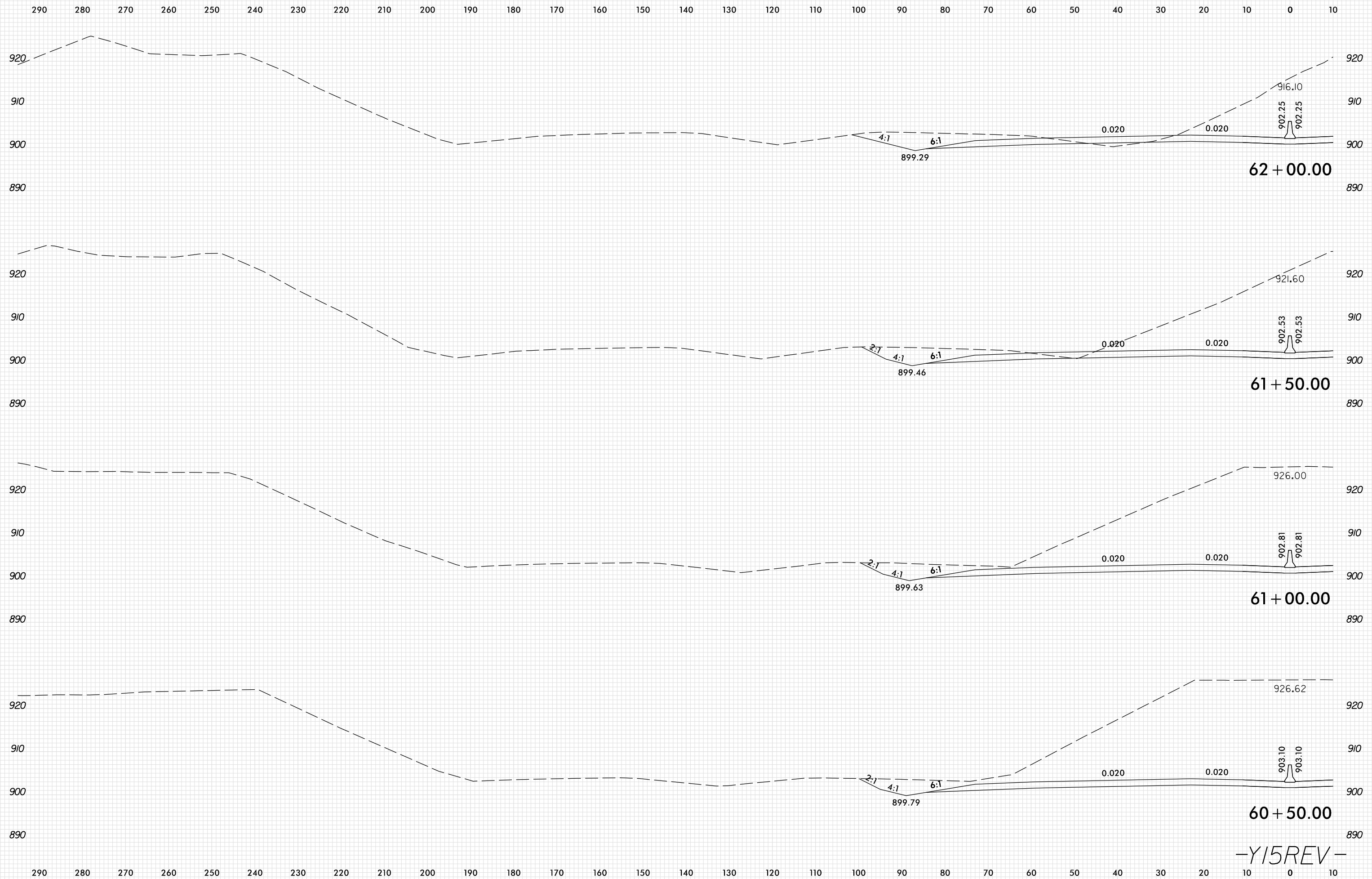

-Y15REV-

PLOT DRIVER: NCD01_pdf_color_eng_100.plt
 USER: SPEREIRA
 DATE: 6/10/2021
 TIME: 2:23:00 PM
 FILE: \

8/23/99

0 5 10	PROJ. REFERENCE NO.	SHEET NO.
	U-2579AB	X-302

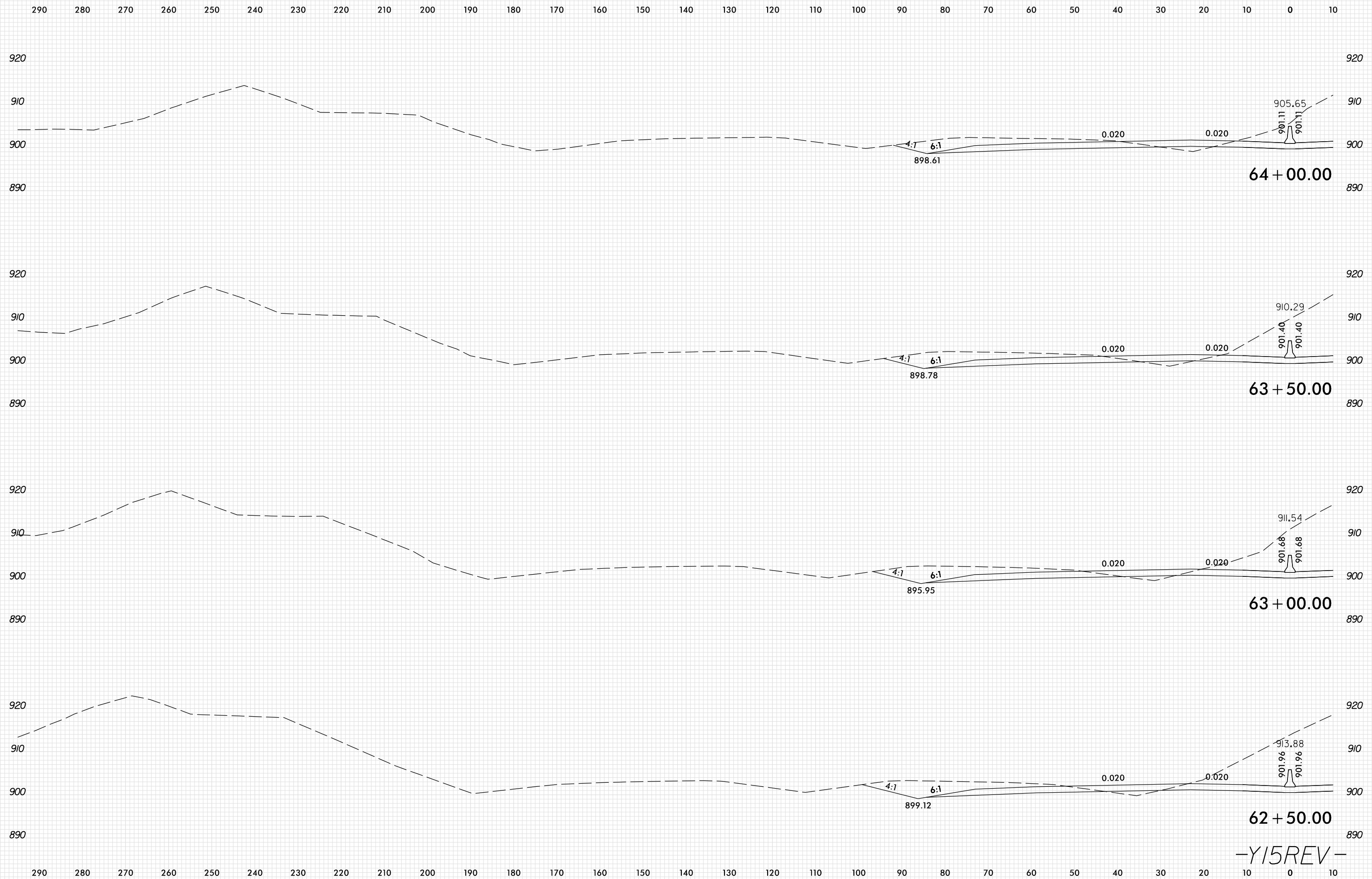

PLOT DRIVER: NCD01_pdf_color_eng_100.plt
 USER: SPEREIRA
 DATE: 6/10/2021
 TIME: 2:23:01 PM
 FILE: \

-Y15REV-

8/23/99

0 5 10	PROJ. REFERENCE NO.	SHEET NO.
	U-2579AB	X-303

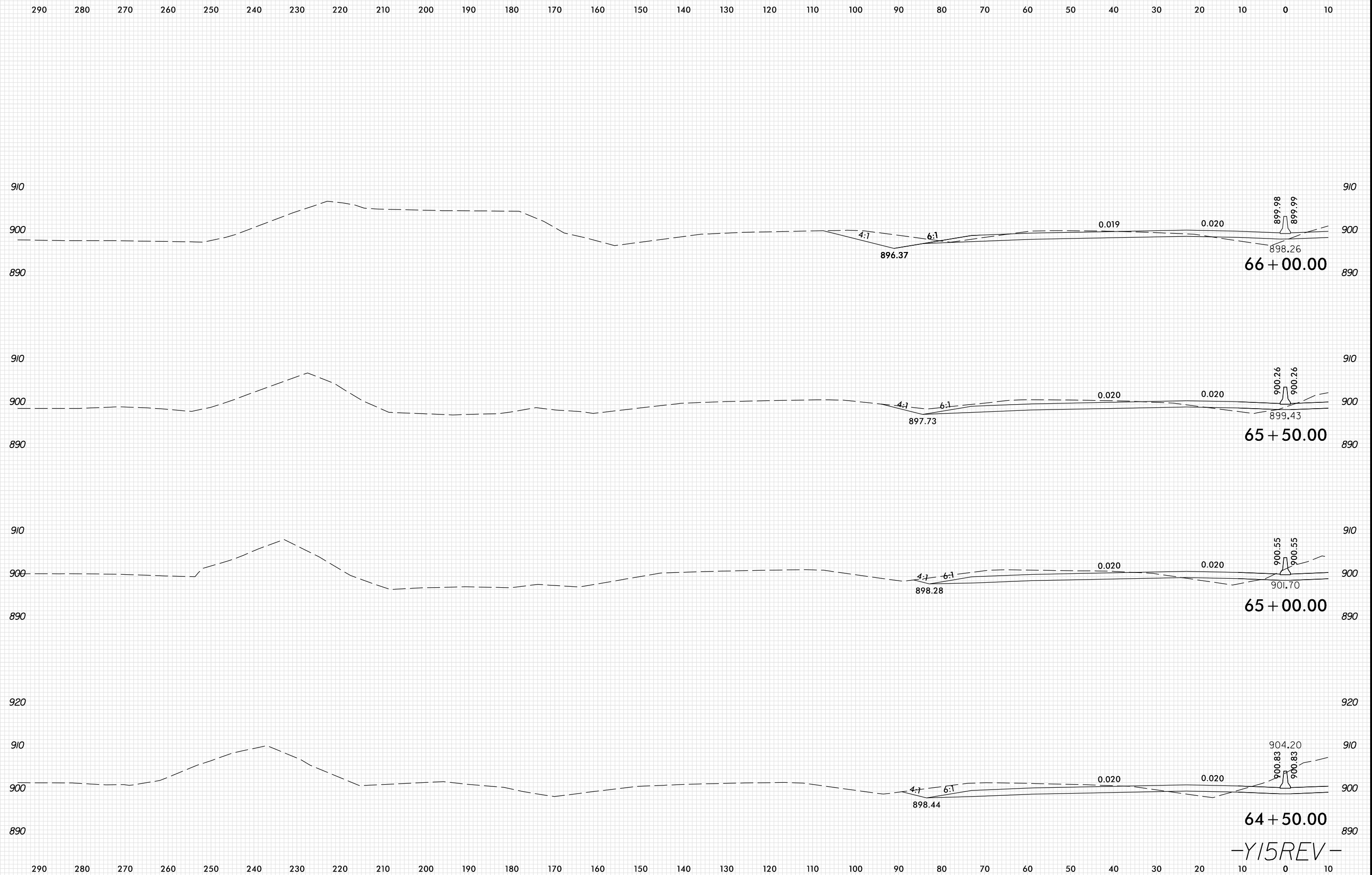

PLOT DRIVER: NCD01_.pdf_color_eng_100.plt
USER: SPEREIRA
DATE: 6/10/2021
TIME: 2:23:01 PM

-Y15REV-

8/23/99

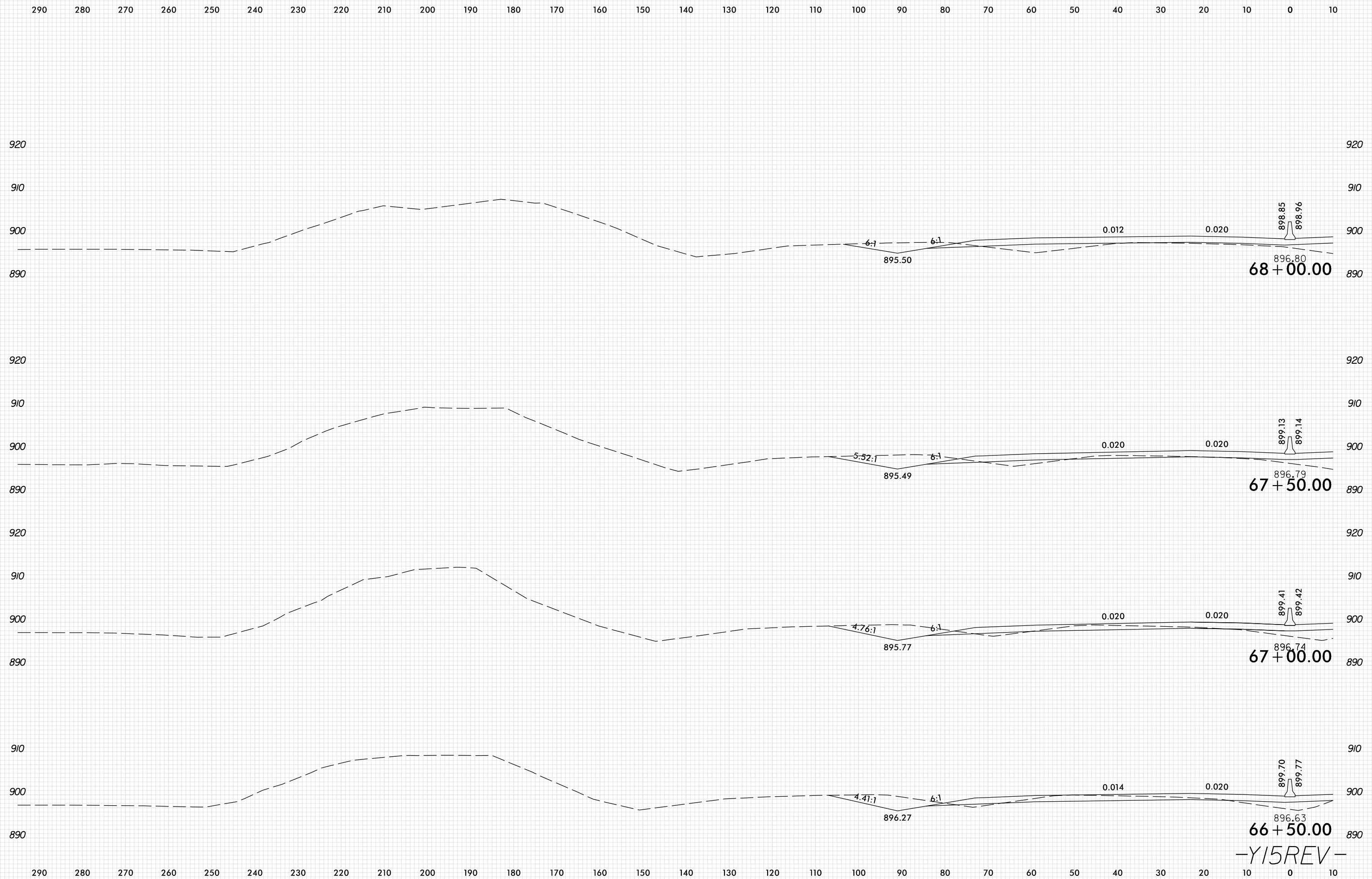

PLOT DRIVER: NCD01_pdf_color_eng_100.plt
 USER: SPEREIRA
 DATE: 6/10/2021
 TIME: 2:23:02 PM
 FILE: \

-Y15REV-

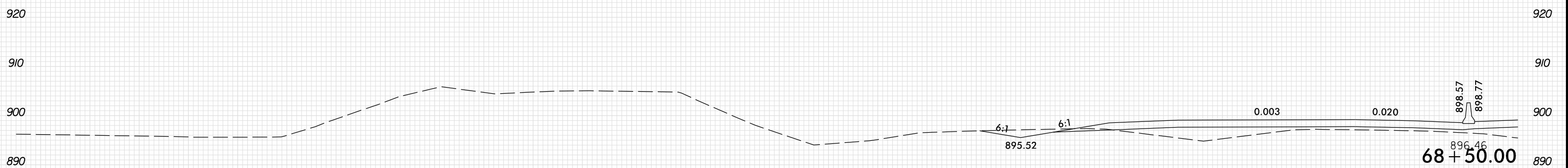
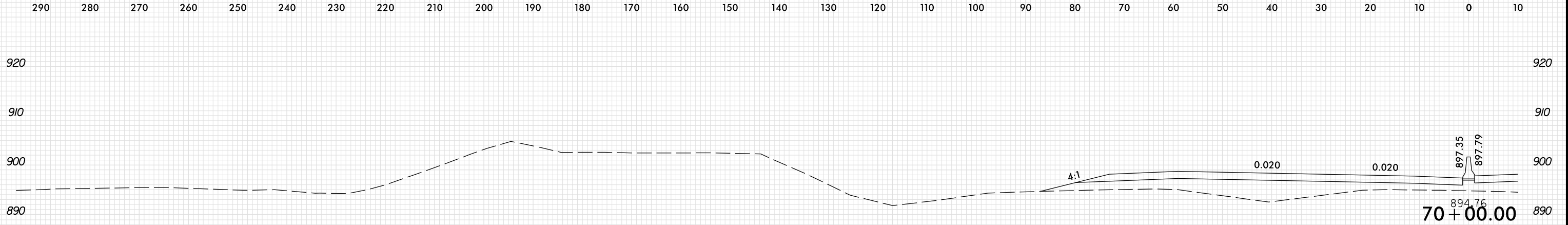

-Y15REV-

8/23/99

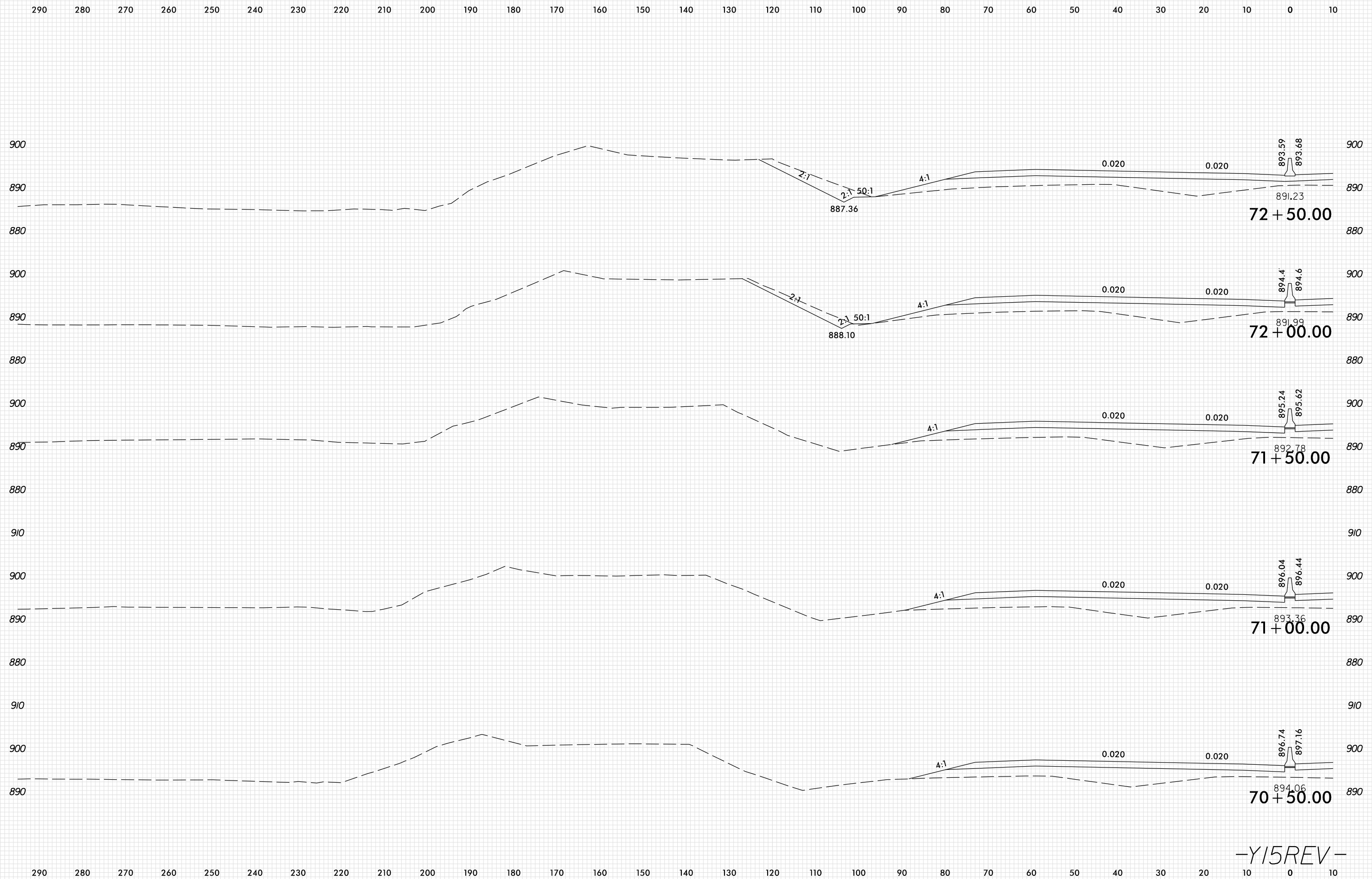

PLOT DRIVER: NCD01_pdf_color_eng_100.plt
 USER: SPEREIRA
 DATE: 6/10/2021
 TIME: 2:23:03 PM
 FILE: \

-Y15REV-

8/23/99

0 5 10	PROJ. REFERENCE NO.	SHEET NO.
	U-2579AB	X-307

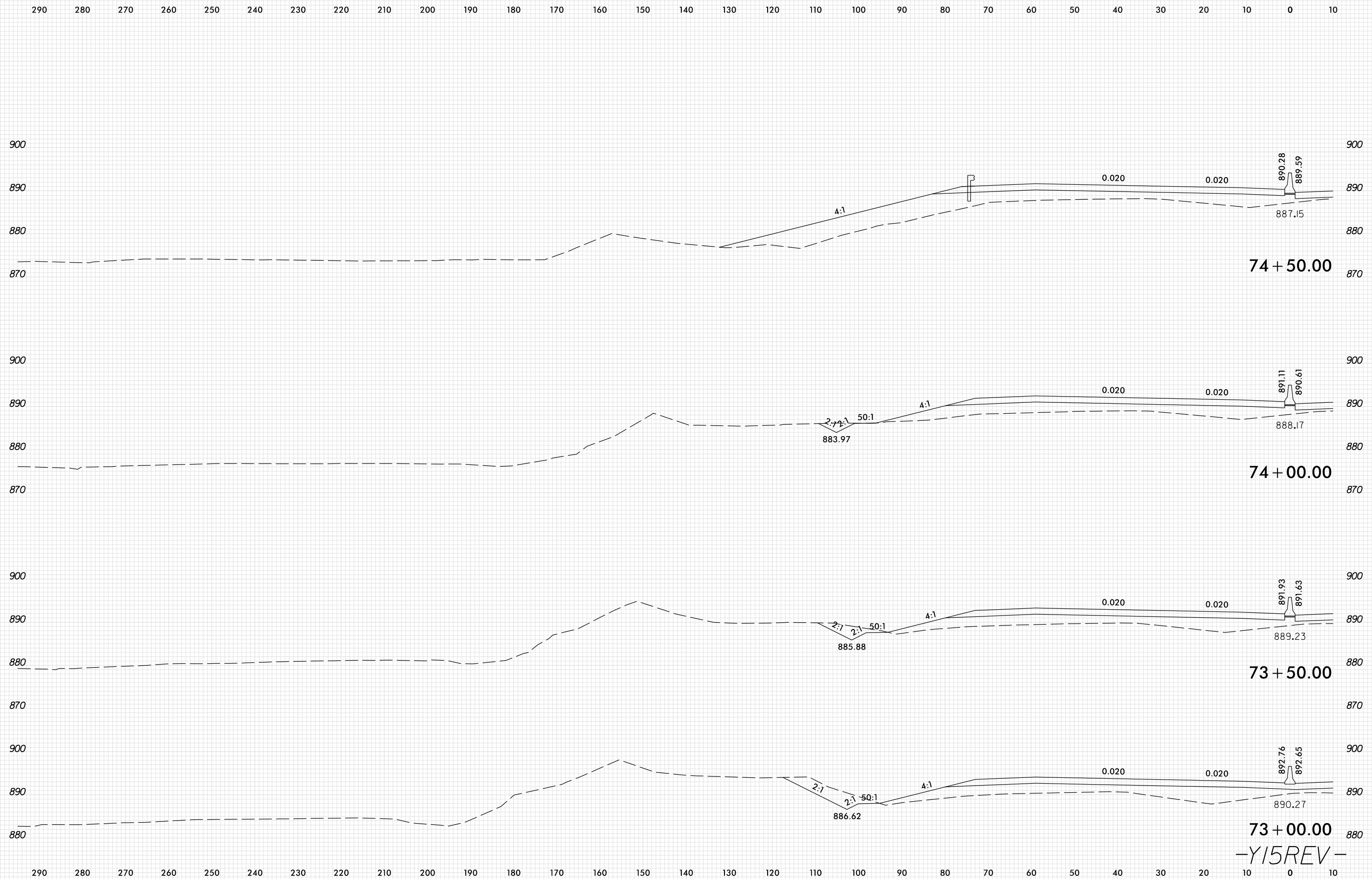

PLOT DRIVER: NCD01.pdf_color_eng_100.plt
 USER: SPEREIRA
 DATE: 6/10/2021
 TIME: 2:23:04 PM
 FILE: \

73+00.00
 -Y15REV-

8/23/99

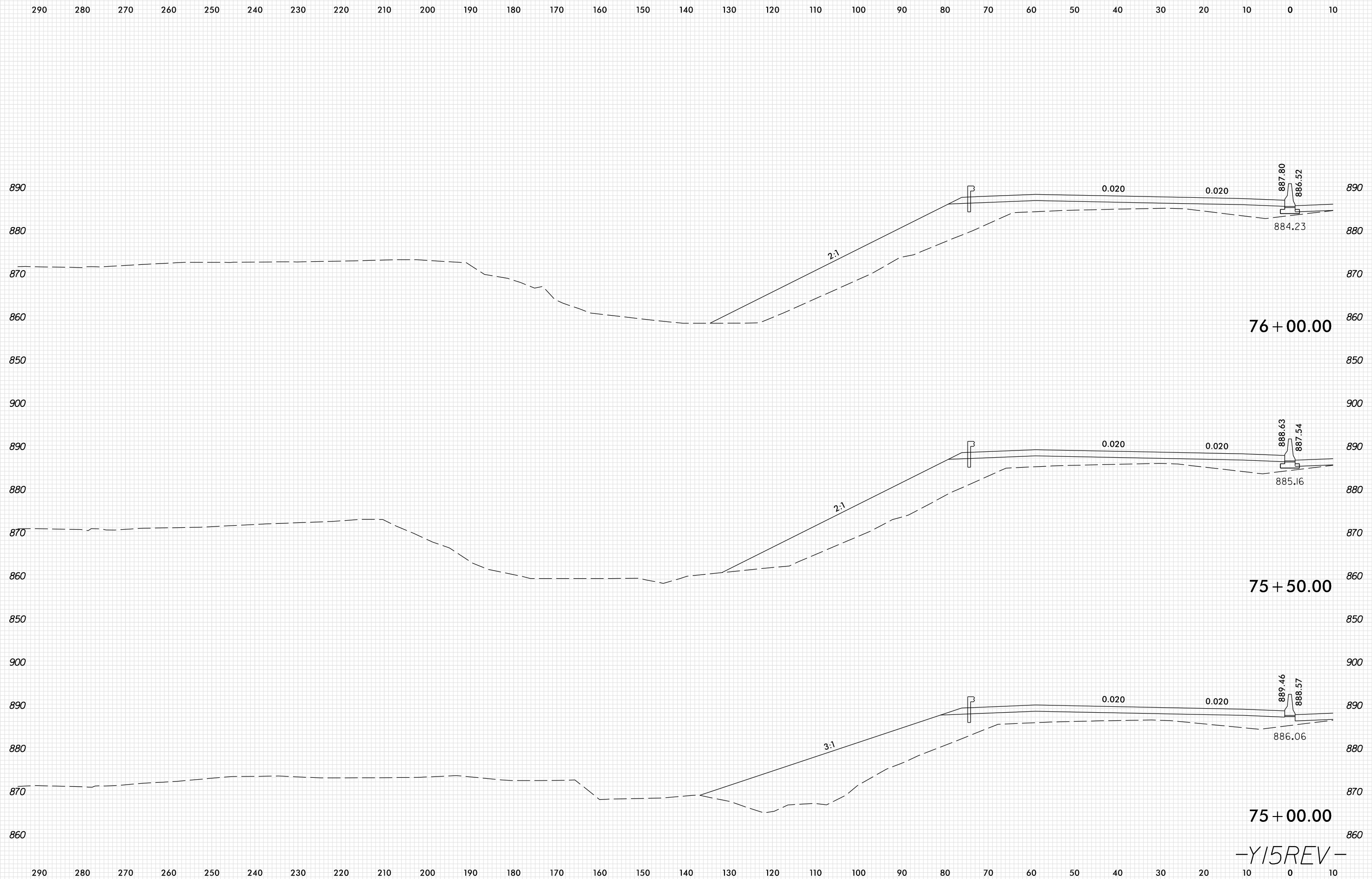

PLOT DRIVER: NCD01_pdf_color_eng_100.plt
 USER: SPEREIRA
 DATE: 6/10/2021
 TIME: 2:23:05 PM
 FILE: \

-Y15REV-

8/23/99

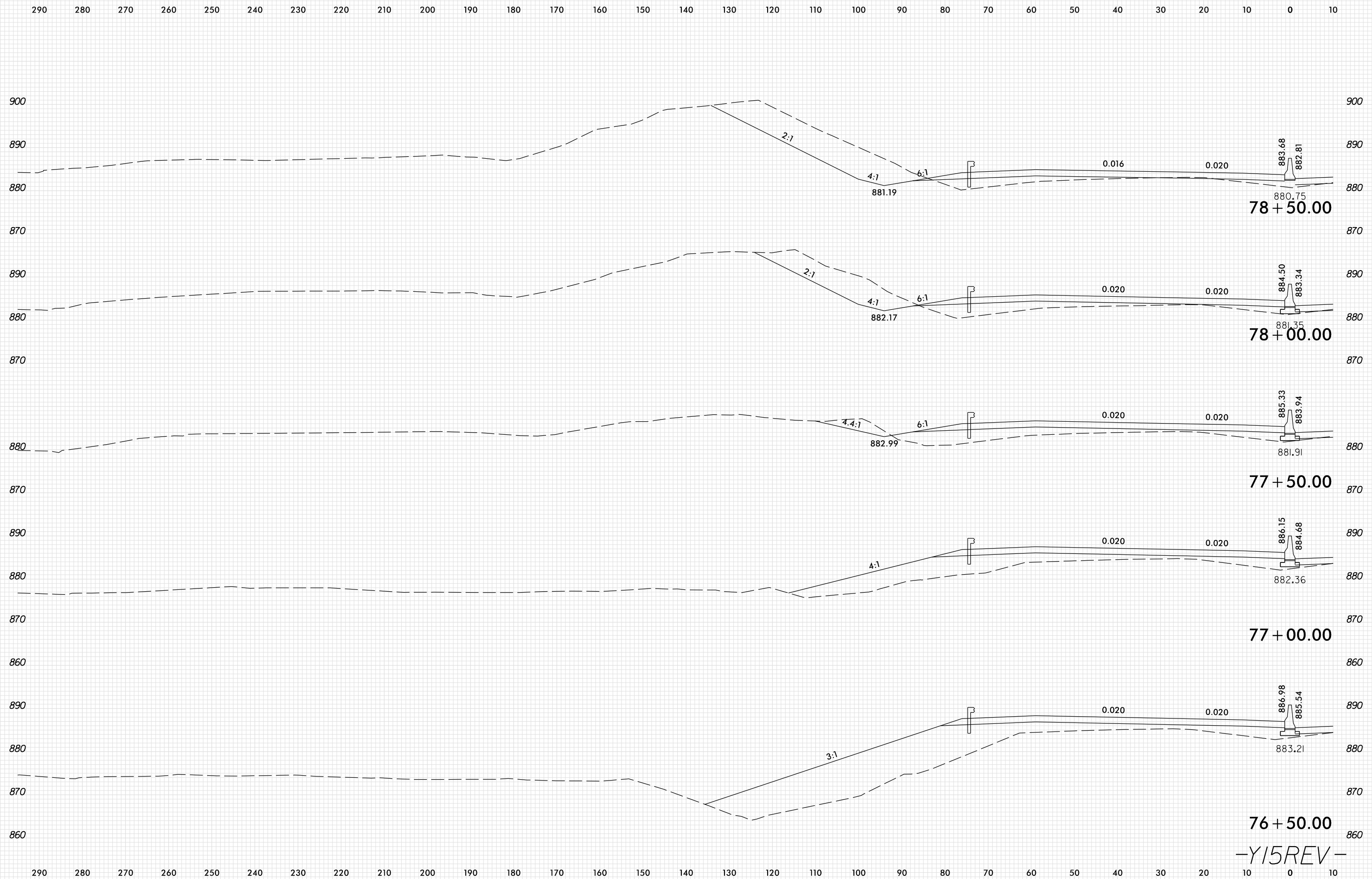

-Y15REV-

PLOT DRIVER: NCD01_pdf_color_eng_100.plt
 USER: SPEREIRA
 DATE: 6/10/2021
 TIME: 2:23:05 PM
 FILE: \

8/23/99

0 5 10	PROJ. REFERENCE NO.	SHEET NO.
	U-2579AB	X-310

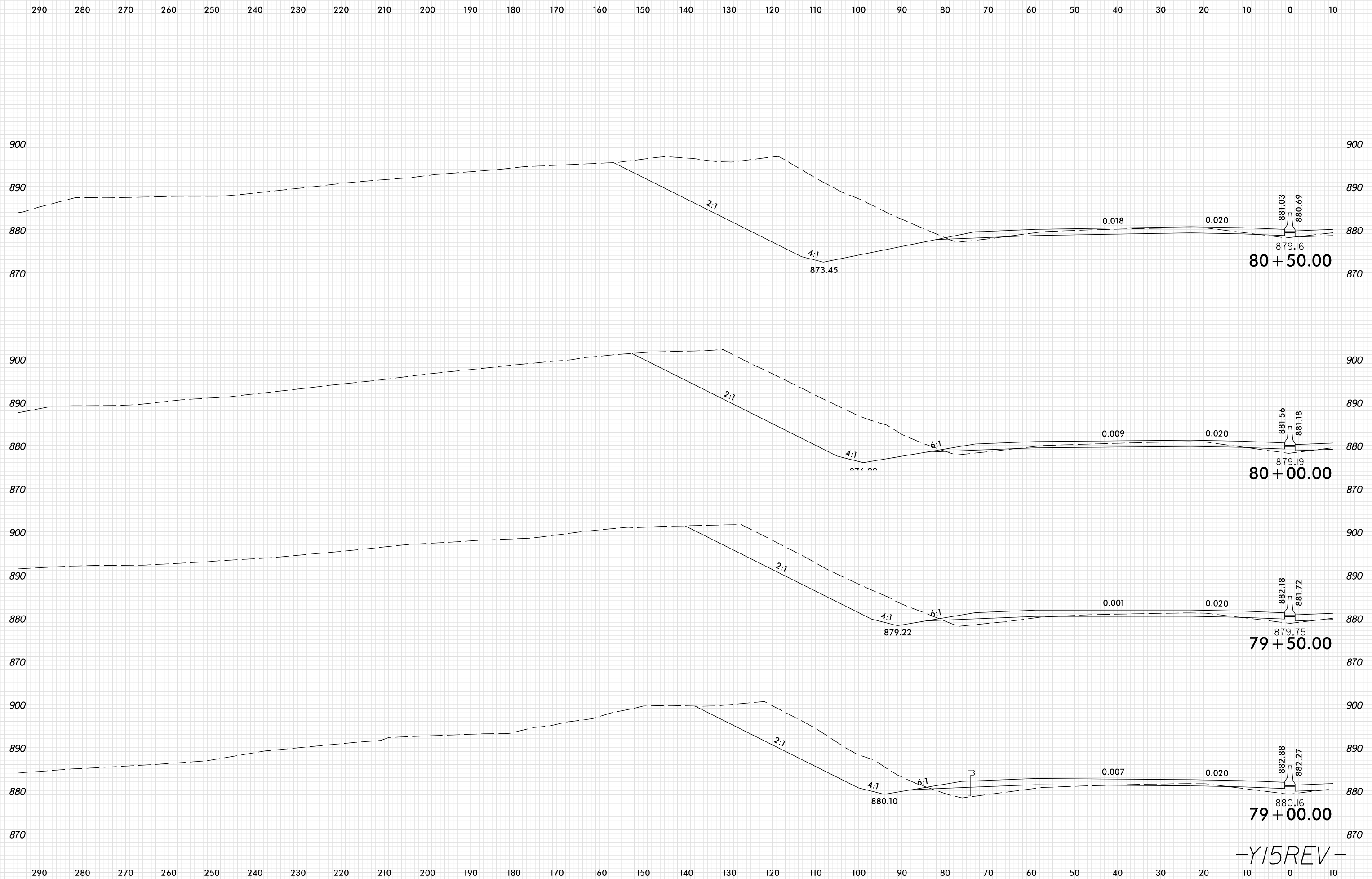

-Y15REV-

PLOT DRIVER: NCD01_pdf_color_eng_100.plt
 USER: SPEREIRA
 DATE: 6/10/2021
 TIME: 2:23:06 PM
 FILE: \

8/23/99

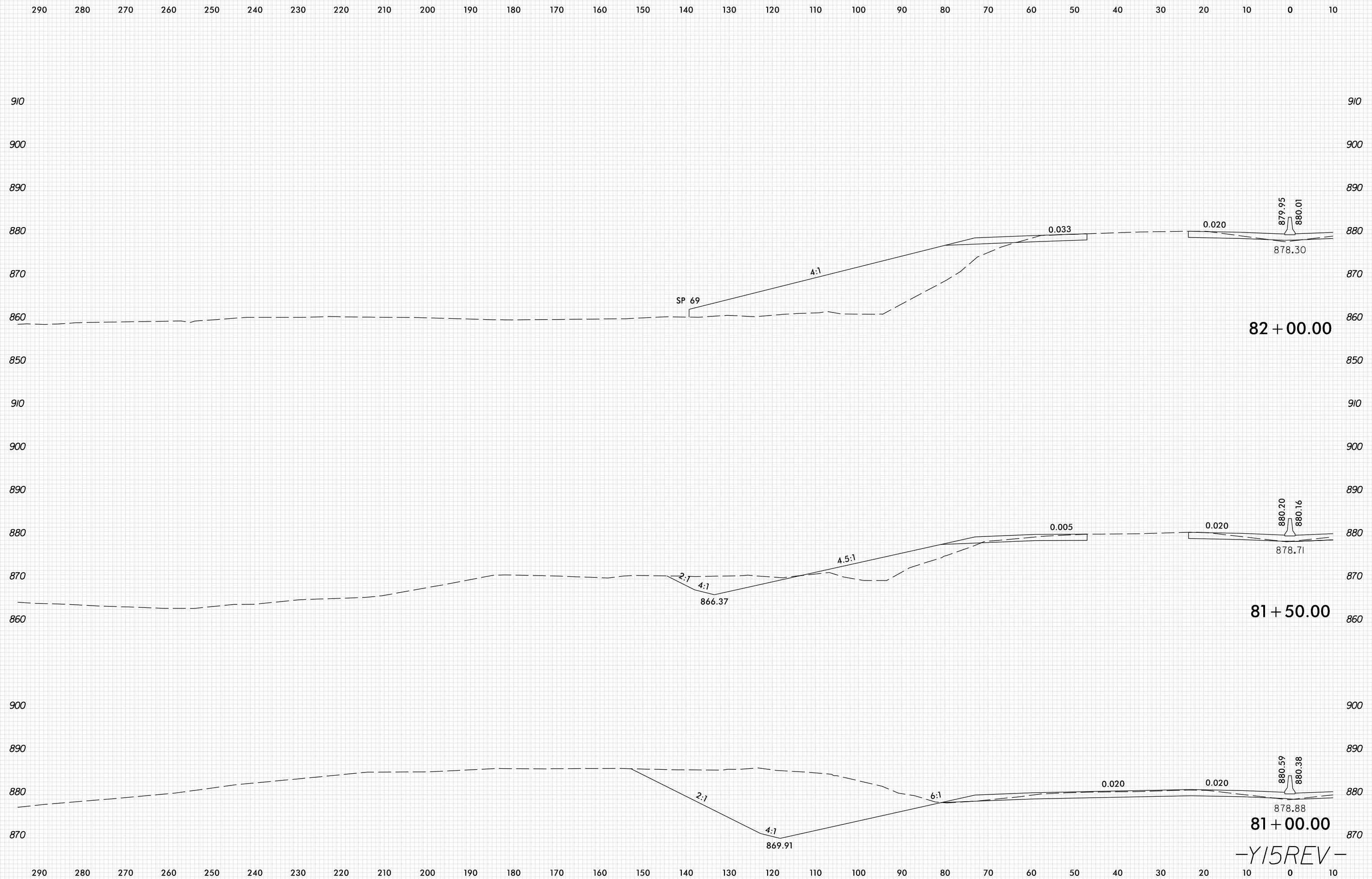

PLOT DRIVER: NCD01_pdf_color_eng_100.plt
 USER: SPEREIRA
 DATE: 6/10/2021
 TIME: 2:23:07 PM
 FILE: \

-Y15REV-

8/23/99

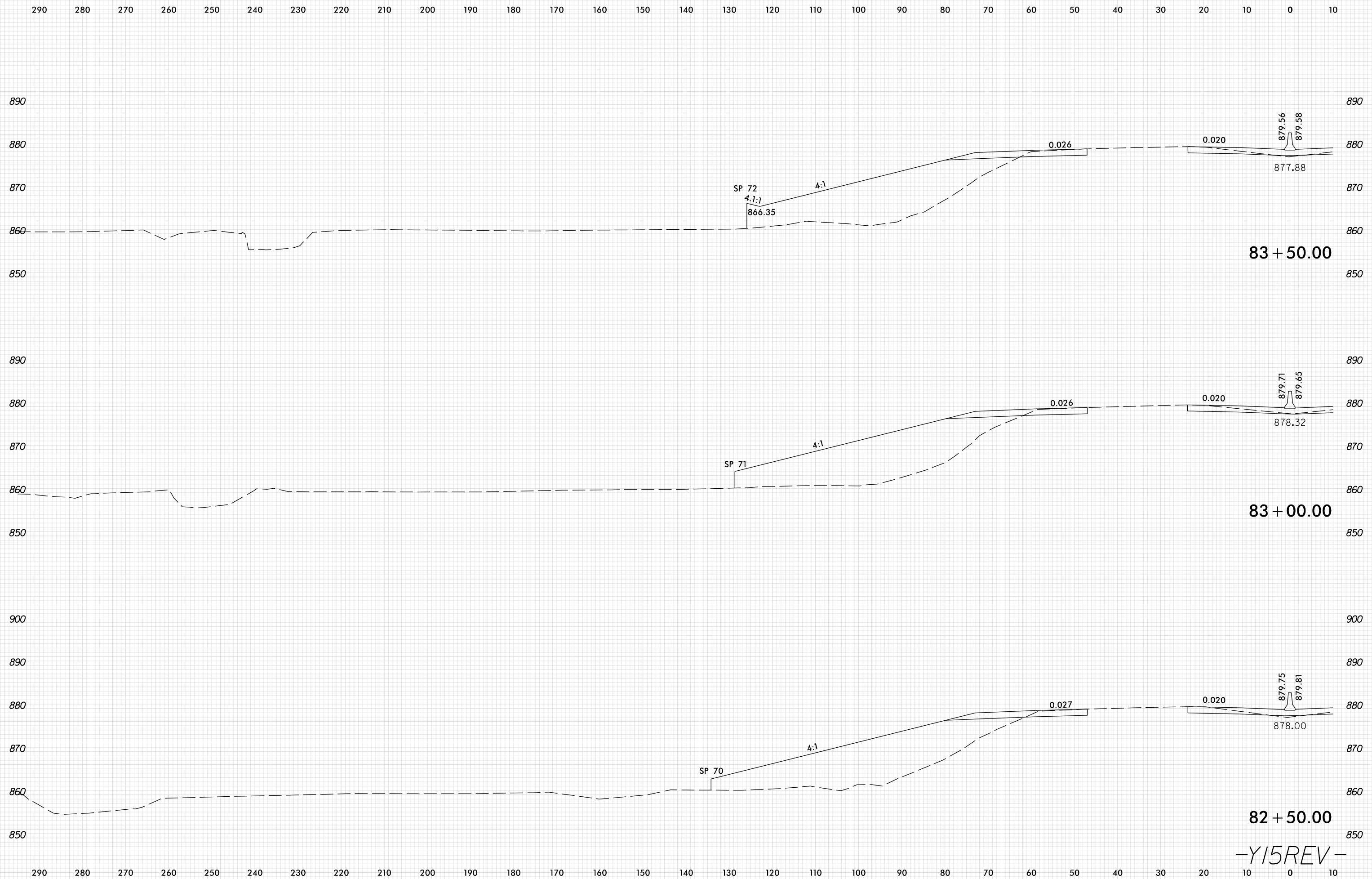

PLOT DRIVER: NCDOT_pdf_color_eng_100.plt
 USER: SPEREIRA
 DATE: 6/10/2021
 TIME: 2:23:07 PM
 FILE: \

-Y15REV-

8/23/99

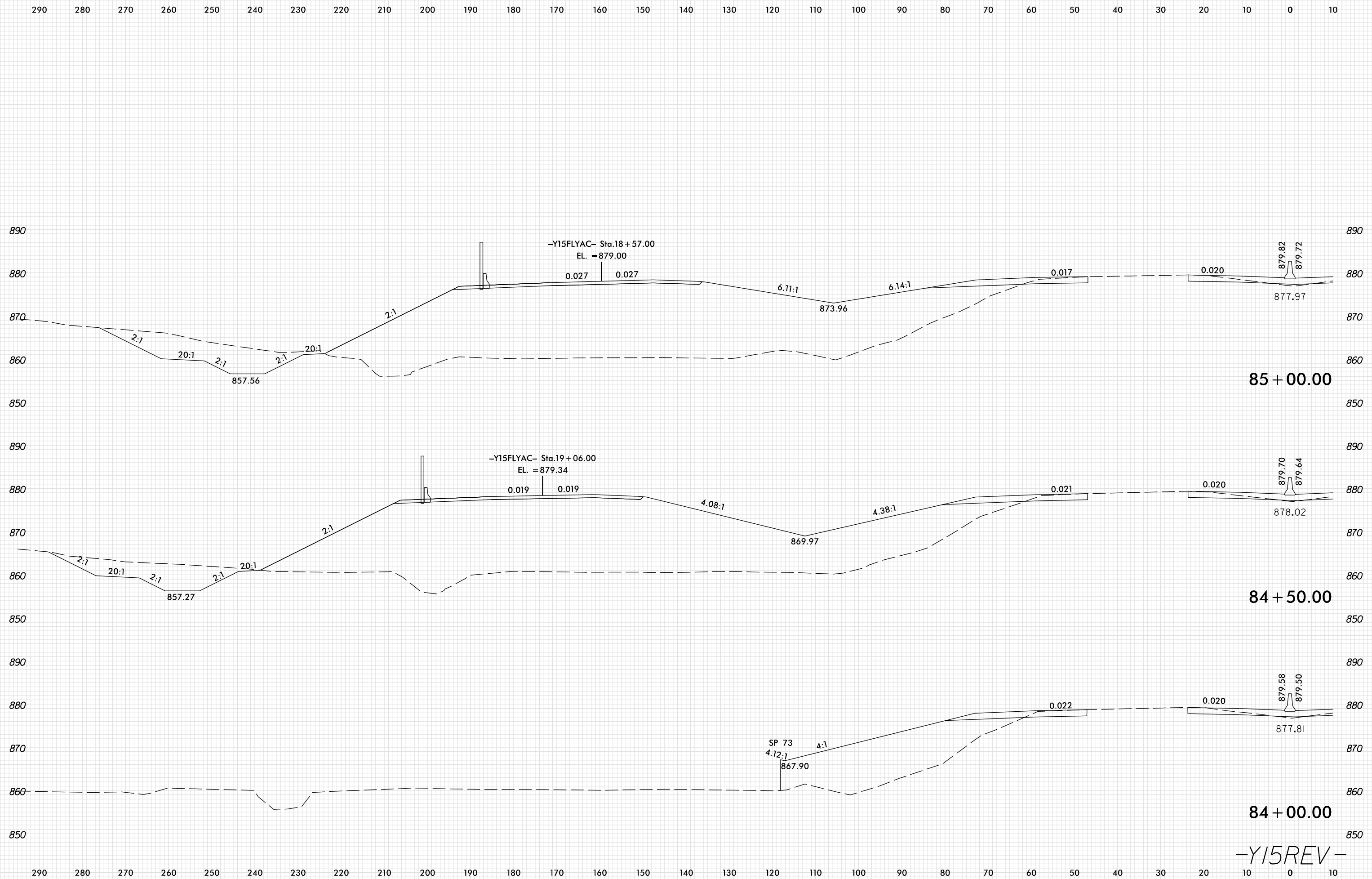

PLOT DRIVER: NCD01_pdf_color_eng_100.plt
 USER: SPEREIRA
 DATE: 6/10/2021
 TIME: 2:23:08 PM
 FILE: \

-Y15REV-

8/23/99

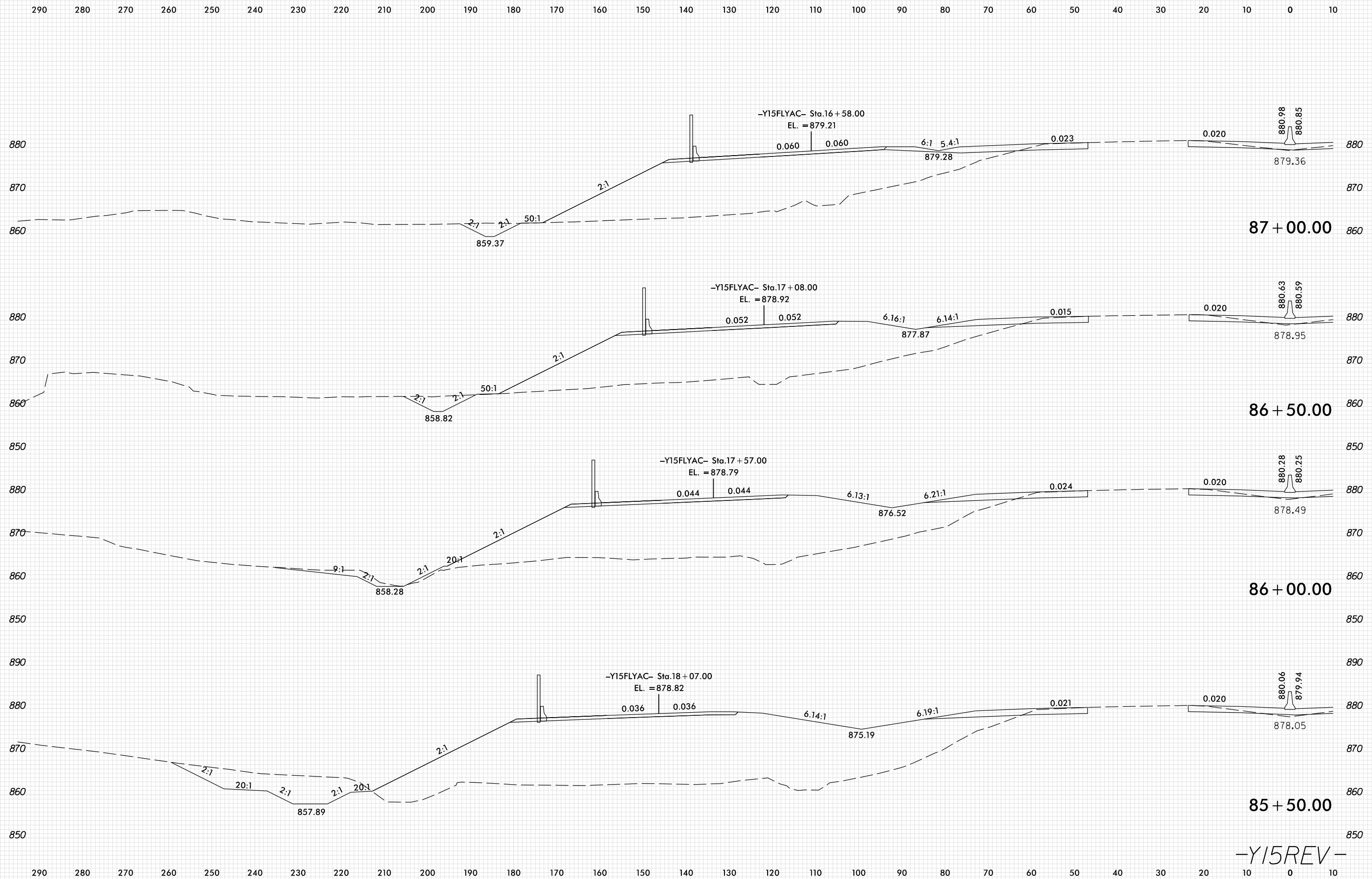

-Y15REV-

PLOT DRIVER: NCDOT_pdf_color_eng_100.plt
 USER: SPEREIRA
 DATE: 6/10/2021
 TIME: 2:23:09 PM
 FILE: \

8/23/99

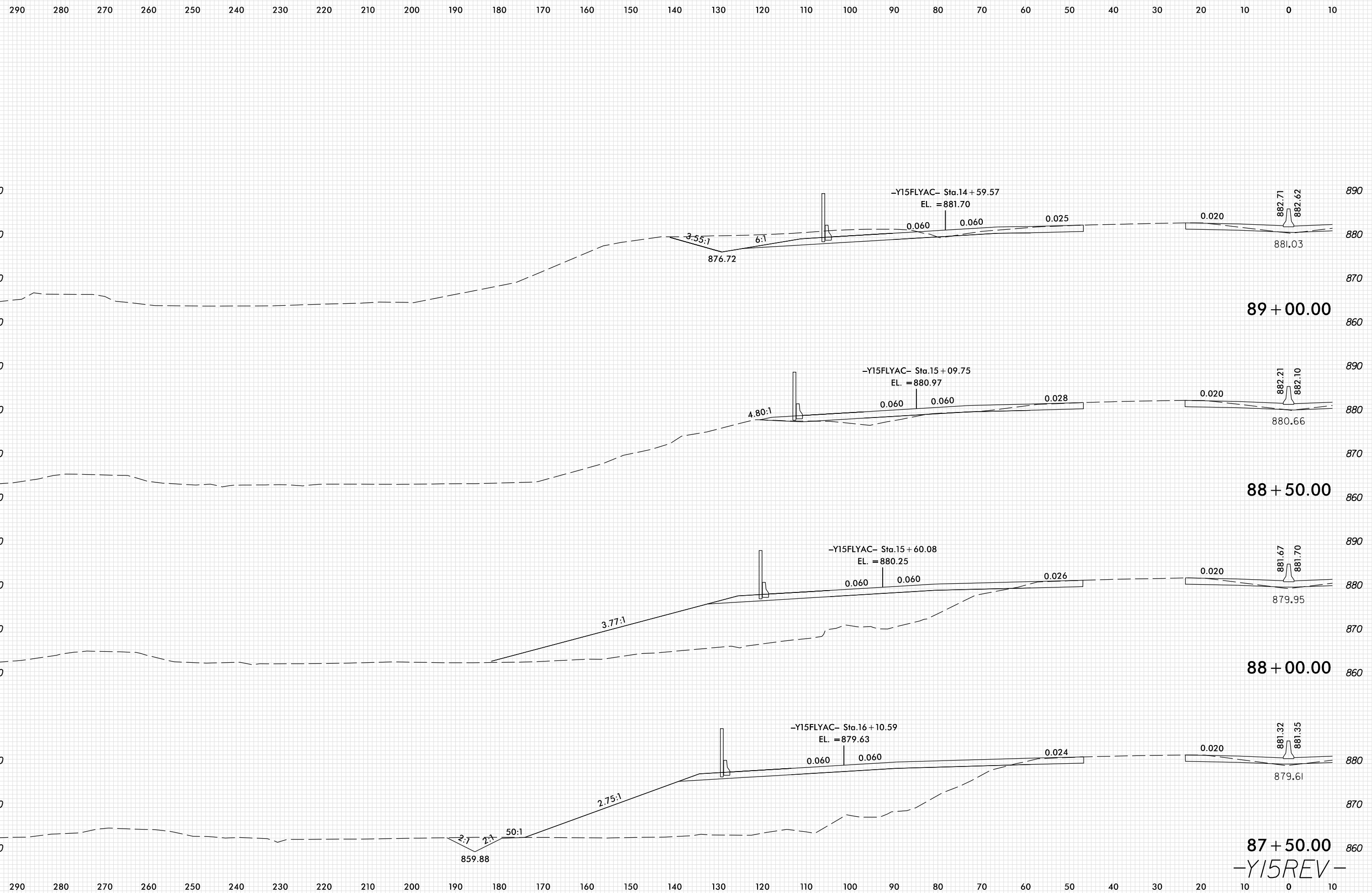

PLOT DRIVER: NCD01.pdf_color_eng_100.plt
 USER: SPEREIRA
 DATE: 6/10/2021
 TIME: 2:23:10 PM
 FILE: \

87 + 50.00
 -Y15REV-

8/23/99

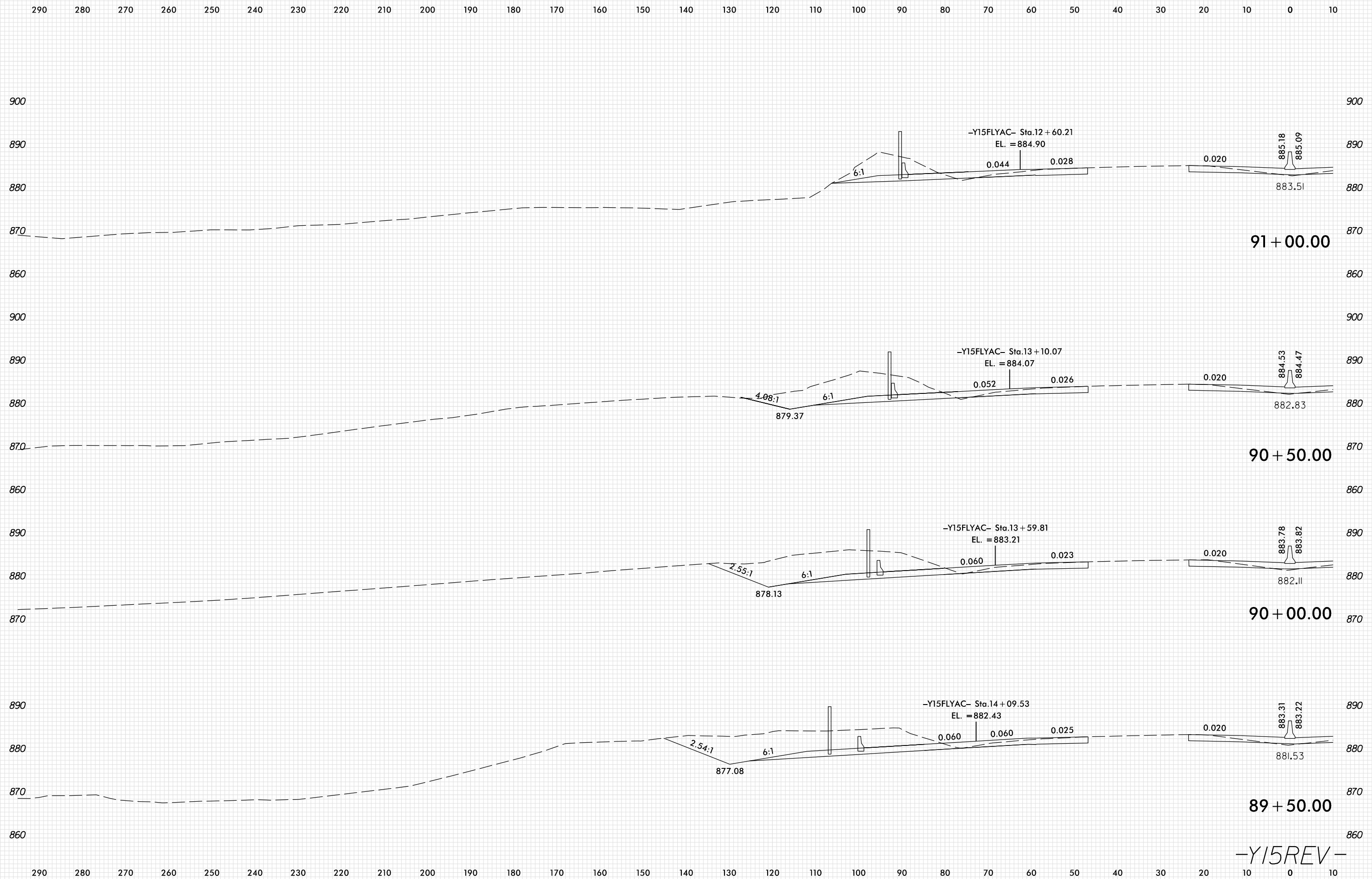

-Y15REV-

PLOT DRIVER: NCD01_.pdf_color_eng_100.plt
 USER: SPEREIRA
 DATE: 6/10/2021
 TIME: 2:23:10 PM
 FILE: \

8/23/99

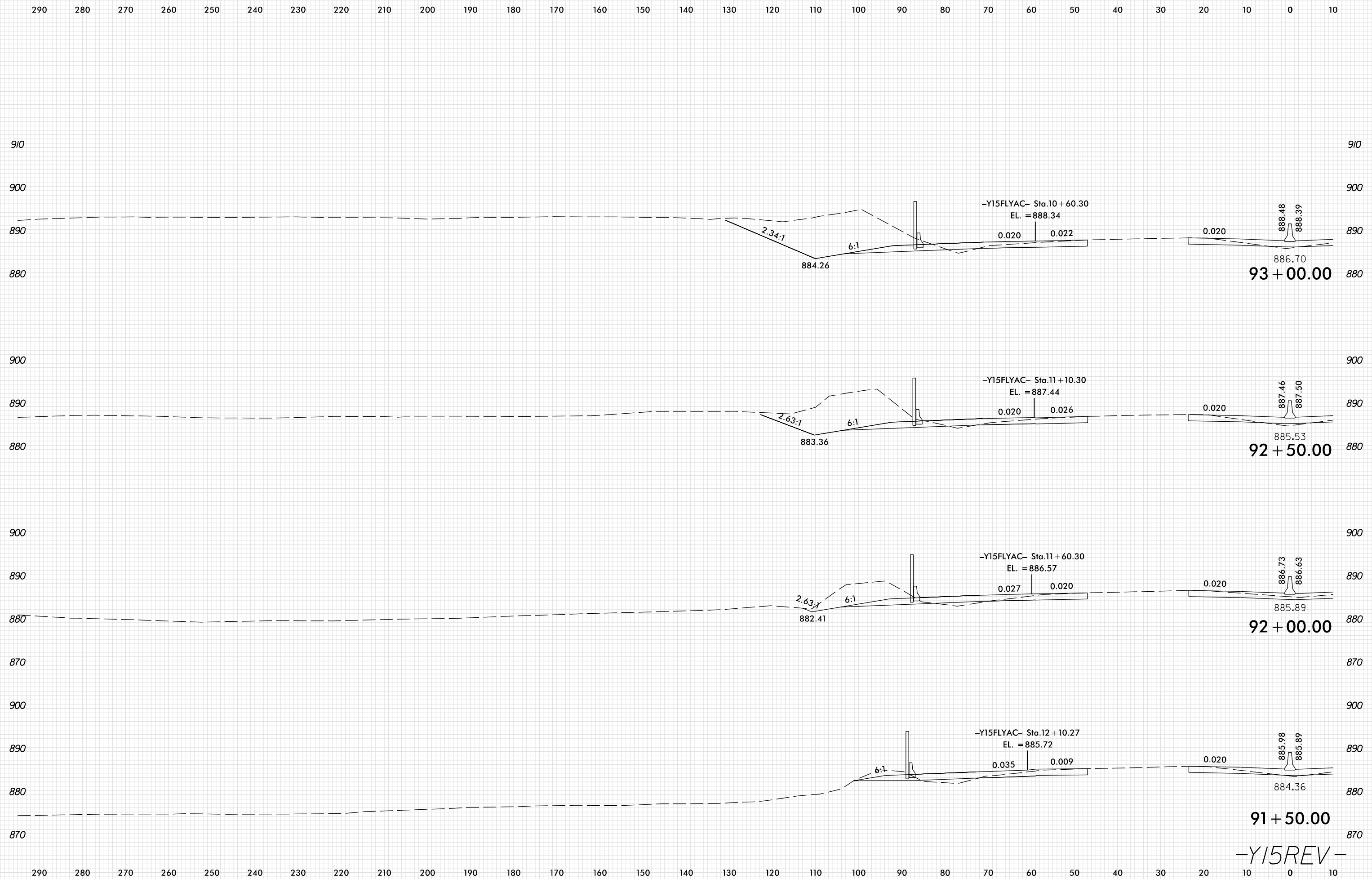

-Y15REV-

PLOT DRIVER: NCD01_pdf_color_eng_100.plt
 USER: SPEREIRA
 DATE: 6/10/2021
 TIME: 2:23:11 PM
 FILE: \

8/23/99

0 5 10	PROJ. REFERENCE NO.	SHEET NO.
	U-2579AB	X-318

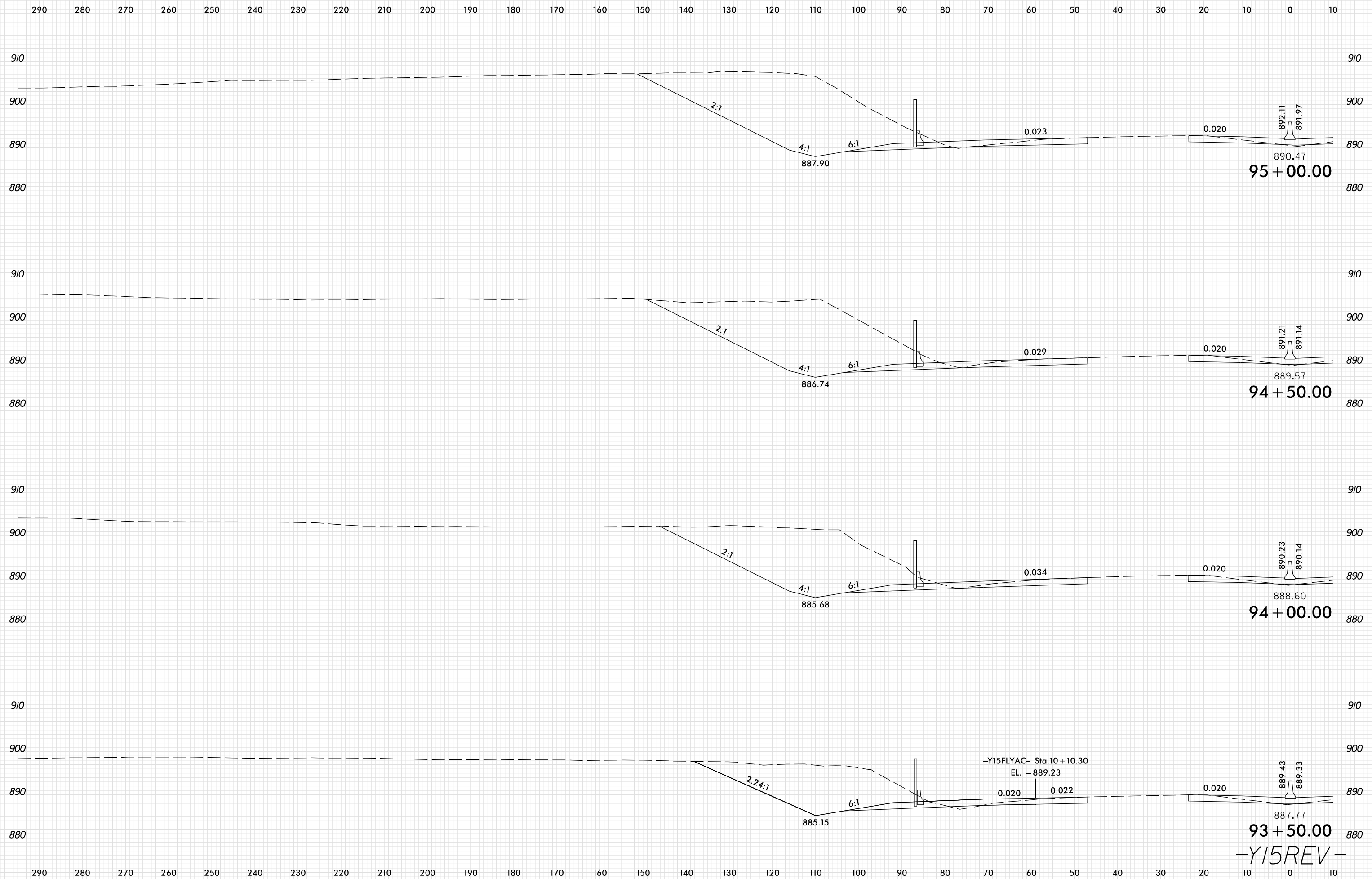

PLOT DRIVER: NCDOT_pdf_color_eng_100.plt
 USER: SPEREIRA
 DATE: 6/10/2021
 TIME: 2:23:12 PM
 FILE: \

-Y15REV-

8/23/99

0 5 10	PROJ. REFERENCE NO.	SHEET NO.
	U-2579AB	X-319

290 280 270 260 250 240 230 220 210 200 190 180 170 160 150 140 130 120 110 100 90 80 70 60 50 40 30 20 10 0 10

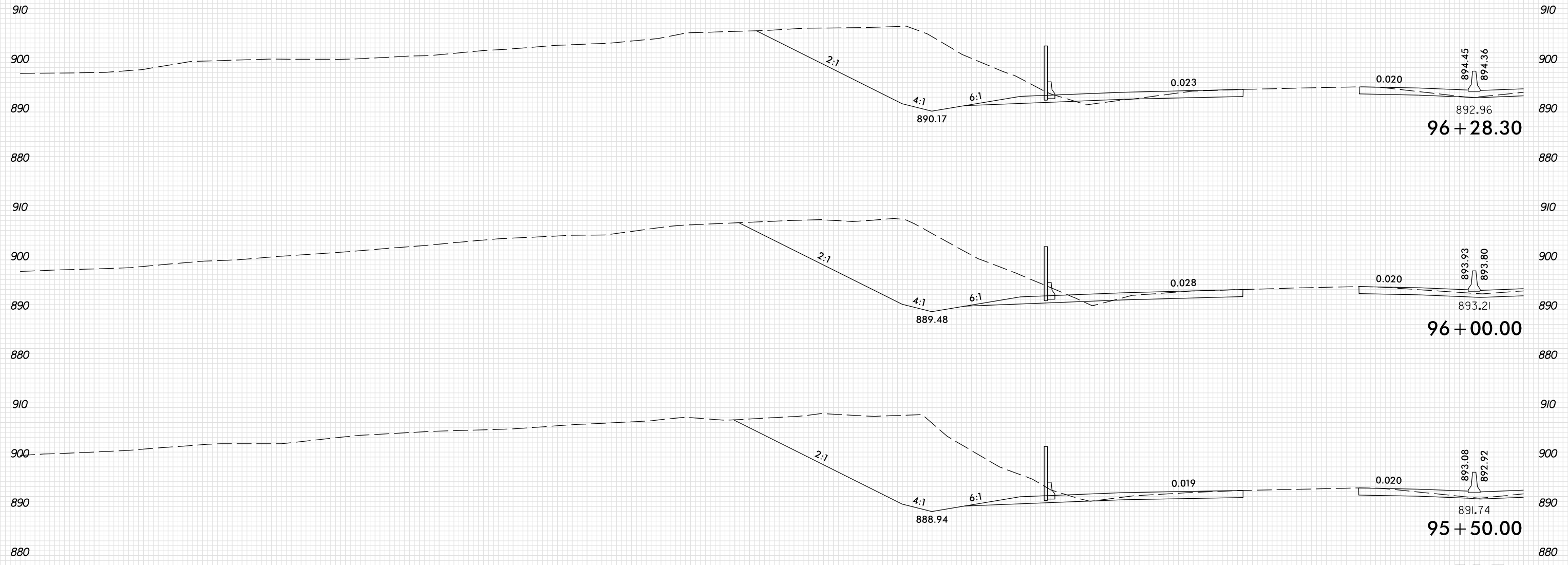

-Y15REV-

PLOT DRIVER: NCD01_.pdf_color_eng_100.plt
 USER: SPEREIRA
 DATE: 6/10/2021
 TIME: 2:23:12 PM
 FILE: \

8/23/99

0 5 10	PROJ. REFERENCE NO.	SHEET NO.
	U-2579AB	X-320

10 0 10 20 30 40 50 60 70 80 90 100 110 120 130 140 150 160 170 180 190 200 210 220 230 240 250 260 270 280 290

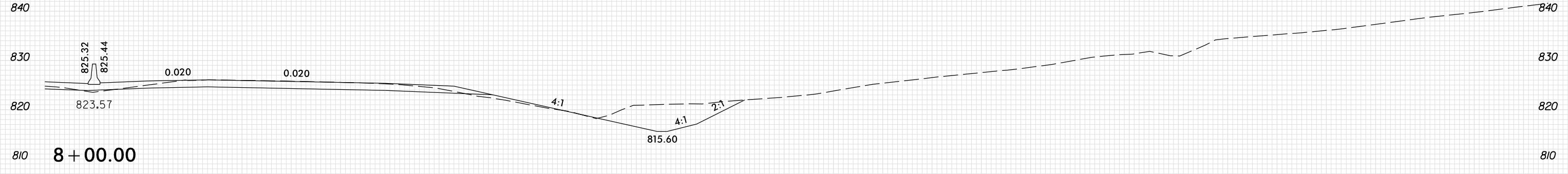
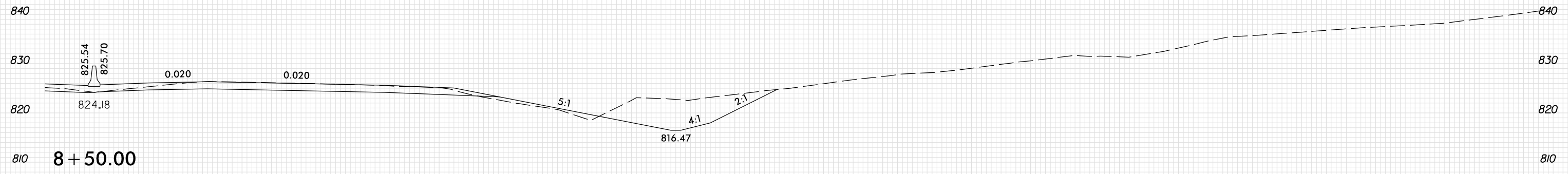
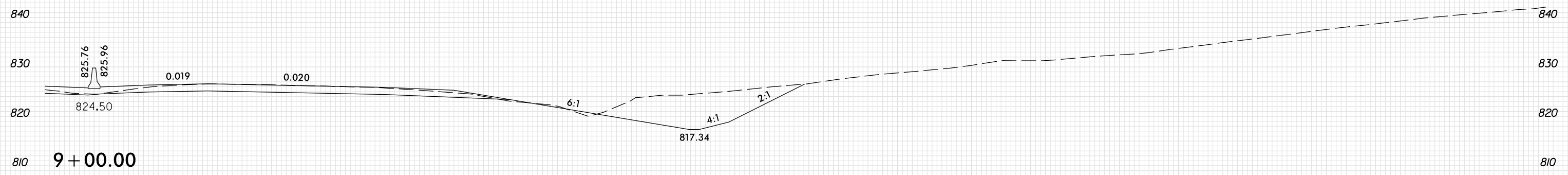

-Y15REV-

10 0 10 20 30 40 50 60 70 80 90 100 110 120 130 140 150 160 170 180 190 200 210 220 230 240 250 260 270 280 290

PLOT DRIVER: NCDOT_pdf_color_eng_100.plt
USER: SPEREIRA
DATE: 6/10/2021
TIME: 2:23:48 PM
FILE: \

8/23/99

0 5 10	PROJ. REFERENCE NO.	SHEET NO.
	U-2579AB	X-321

10 0 10 20 30 40 50 60 70 80 90 100 110 120 130 140 150 160 170 180 190 200 210 220 230 240 250 260 270 280 290

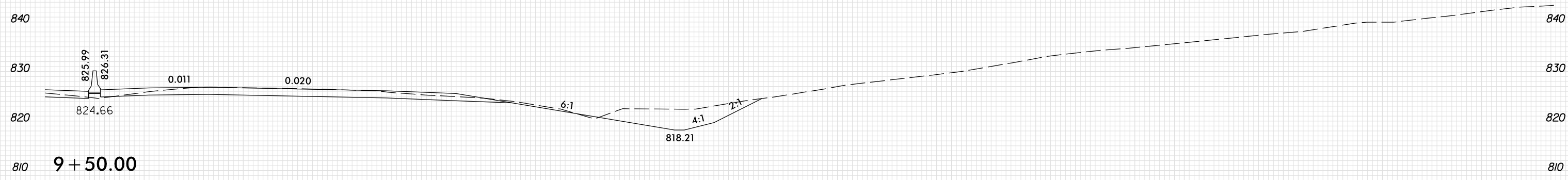
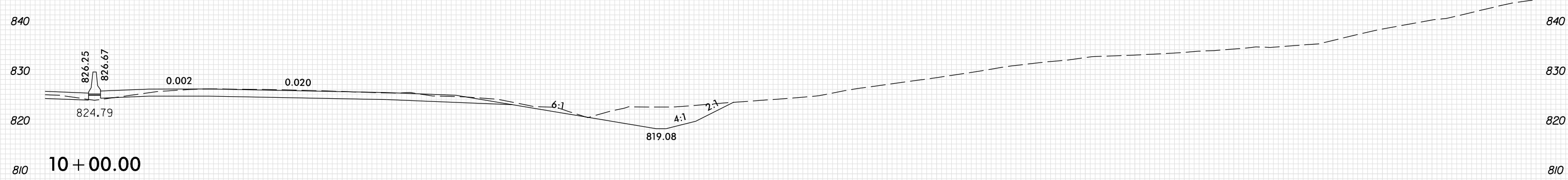
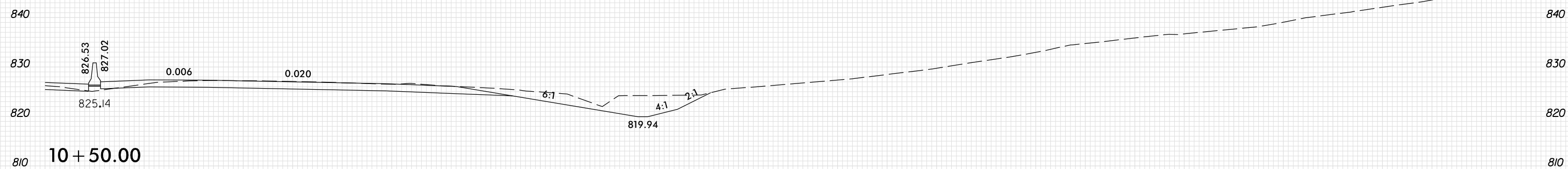

-Y15REV-

10 0 10 20 30 40 50 60 70 80 90 100 110 120 130 140 150 160 170 180 190 200 210 220 230 240 250 260 270 280 290

PLOT DRIVER: NCDOT_pdf_color_eng_100.plt
 USER: SPEREIRA
 DATE: 6/10/2021
 TIME: 2:23:49 PM
 FILE: \

8/23/99

10 0 10 20 30 40 50 60 70 80 90 100 110 120 130 140 150 160 170 180 190 200 210 220 230 240 250 260 270 280 290

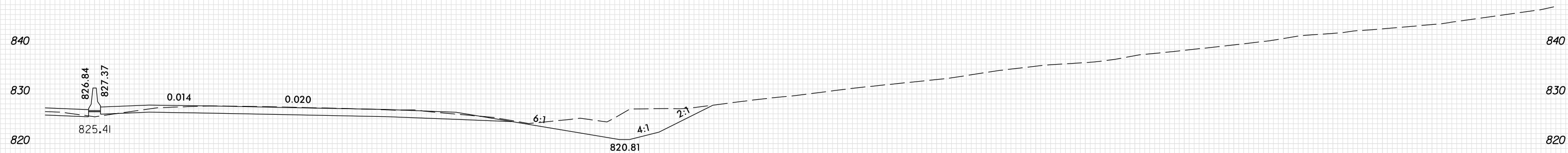
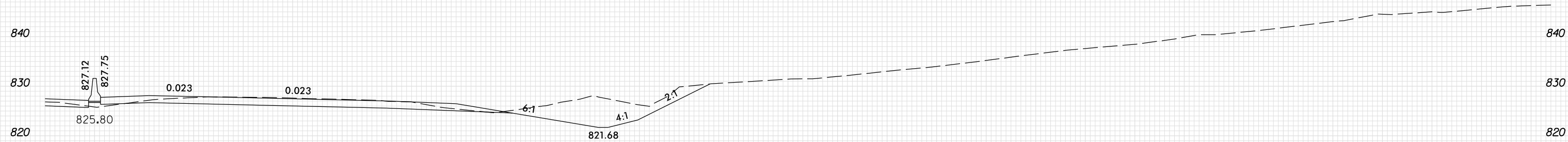
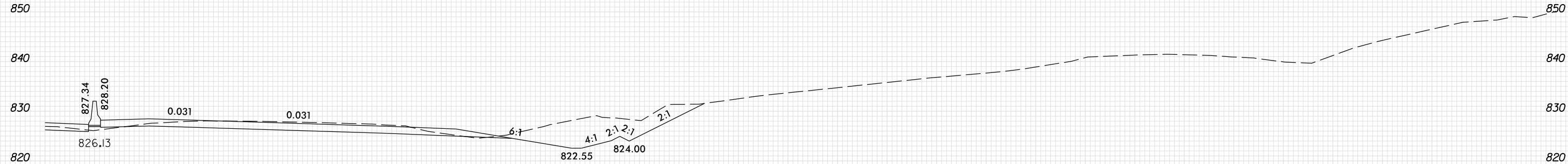

11+00.00
-Y15REV-

10 0 10 20 30 40 50 60 70 80 90 100 110 120 130 140 150 160 170 180 190 200 210 220 230 240 250 260 270 280 290

PLOT DRIVER: NCD01.pdf_color_eng_100.plt
USER: SPEREIRA
DATE: 6/10/2021
TIME: 2:23:50 PM
FILE: \

8/23/99

0 5 10	PROJ. REFERENCE NO.	SHEET NO.
	U-2579AB	X-323

10 0 10 20 30 40 50 60 70 80 90 100 110 120 130 140 150 160 170 180 190 200 210 220 230 240 250 260 270 280 290

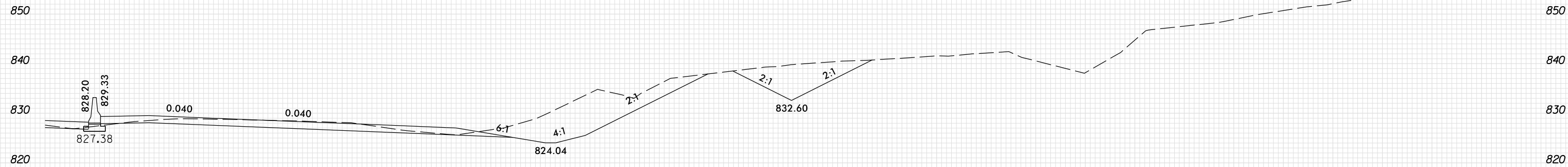

13+50.00

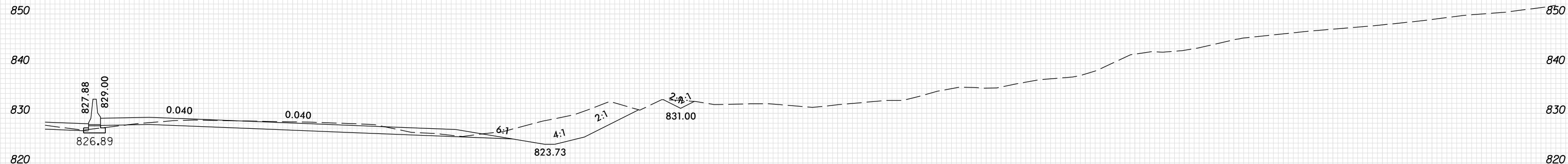

13+00.00

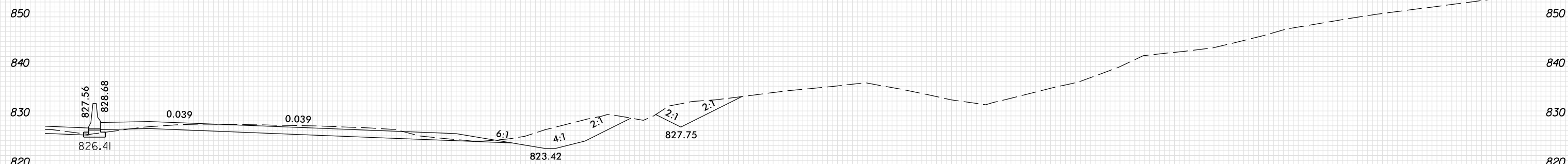

12+50.00

-Y15REV-

10 0 10 20 30 40 50 60 70 80 90 100 110 120 130 140 150 160 170 180 190 200 210 220 230 240 250 260 270 280 290

PLOT DRIVER: NCDOT_pdf_color_eng_100.plt
USER: SPEREIRA
DATE: 6/10/2021
TIME: 2:23:51 PM
FILE: \

8/23/99

0 5 10	PROJ. REFERENCE NO.	SHEET NO.
	U-2579AB	X-324

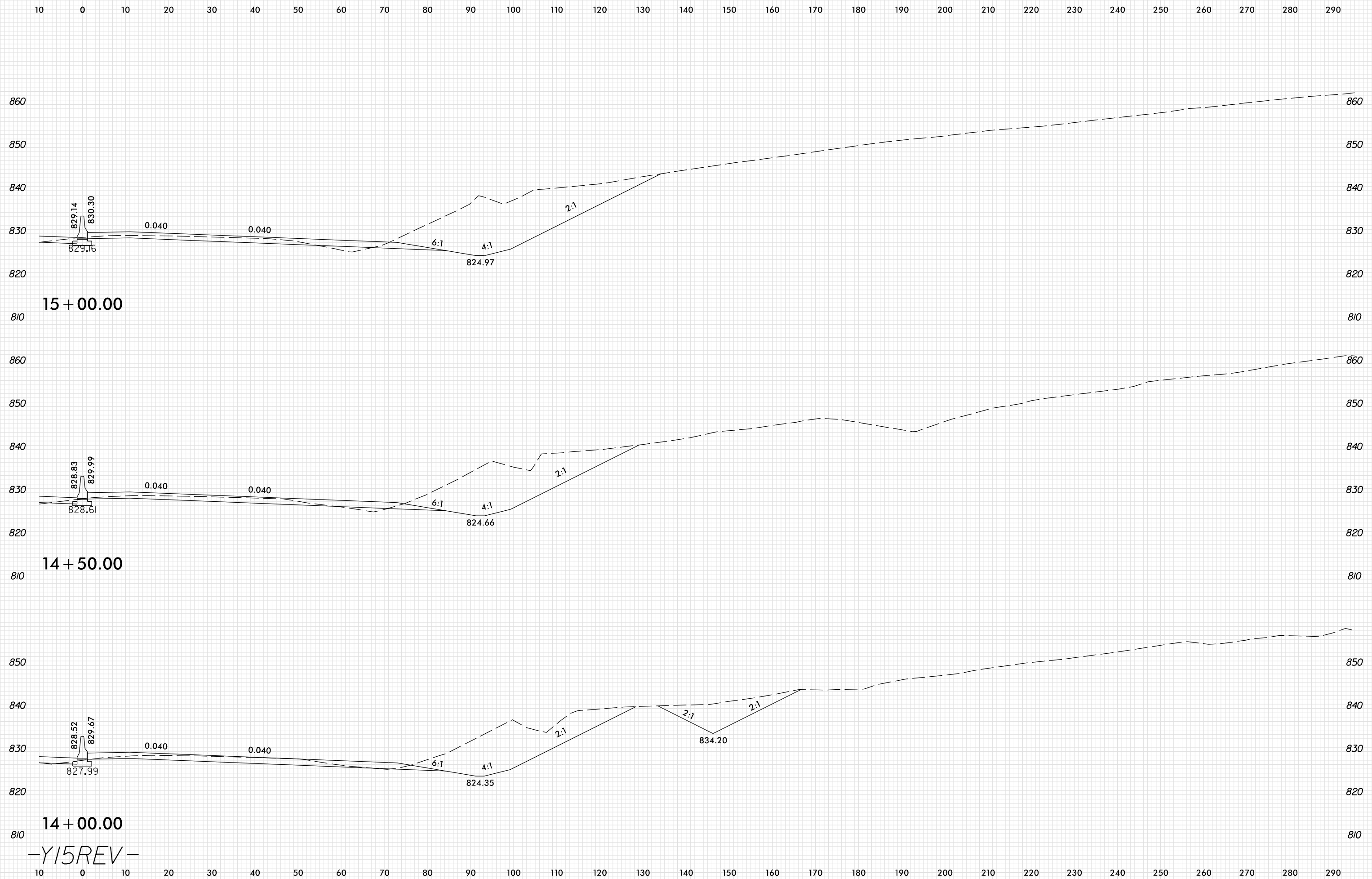

PLOT DRIVER: NCDOT_pdf_color_eng_100.plt
 USER: SPEREIRA
 DATE: 6/10/2021
 TIME: 2:23:52 PM
 FILE: \

14+00.00
 -Y15REV-

8/23/99

0 5 10	PROJ. REFERENCE NO.	SHEET NO.
	U-2579AB	X-325

10 0 10 20 30 40 50 60 70 80 90 100 110 120 130 140 150 160 170 180 190 200 210 220 230 240 250 260 270 280 290

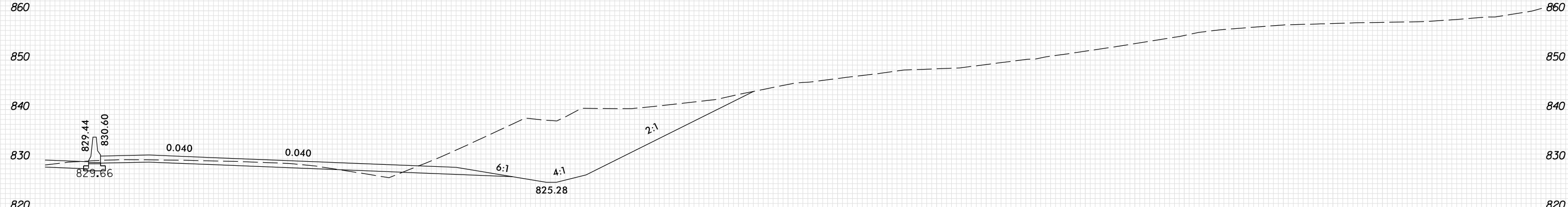
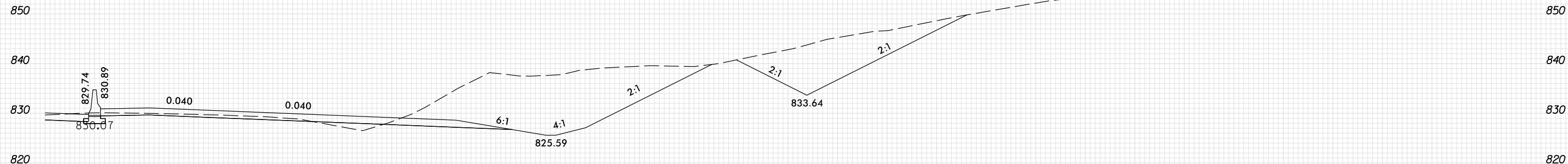
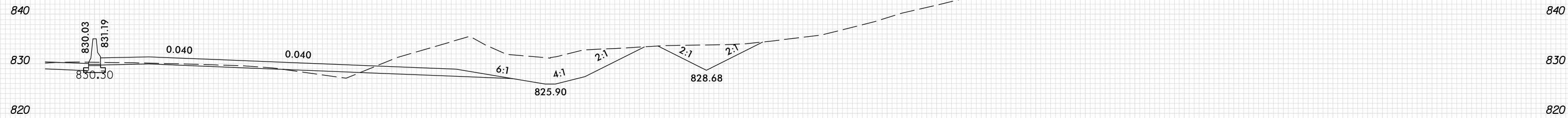

-Y15REV-

10 0 10 20 30 40 50 60 70 80 90 100 110 120 130 140 150 160 170 180 190 200 210 220 230 240 250 260 270 280 290

PLOT DRIVER: NCDOT_pdf_color_eng_100.plt
USER: SPEREIRA
DATE: 6/10/2021
TIME: 2:23:53 PM
FILE: \

8/23/99

0 5 10	PROJ. REFERENCE NO.	SHEET NO.
	U-2579AB	X-326

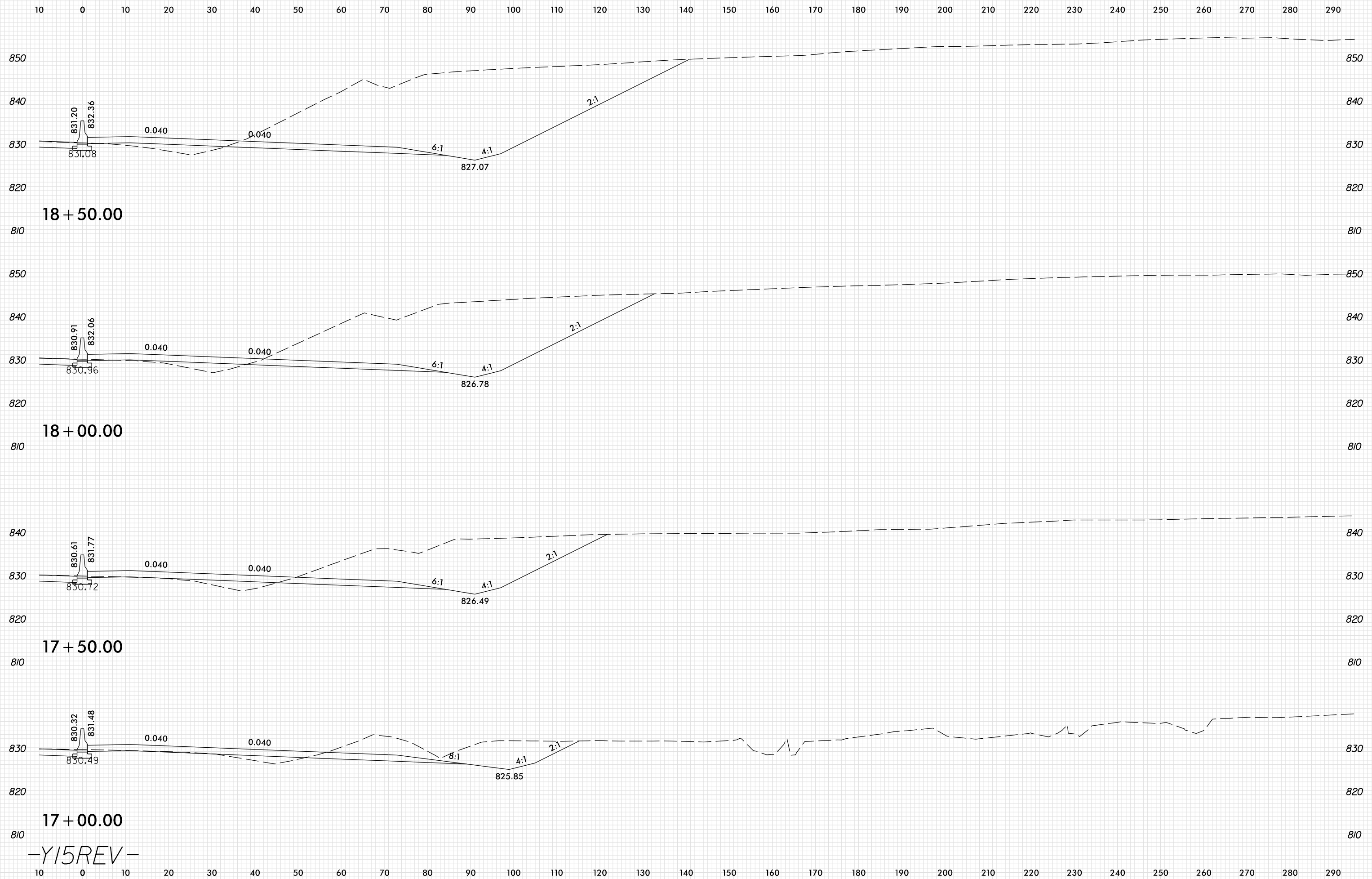

PLOT DRIVER: NCDOT_pdf_color_eng_100.plt
 USER: SPEREIRA
 DATE: 6/10/2021
 TIME: 2:23:53 PM
 FILE: \

-Y15REV-

8/23/99

0 5 10	PROJ. REFERENCE NO.	SHEET NO.
	U-2579AB	X-327

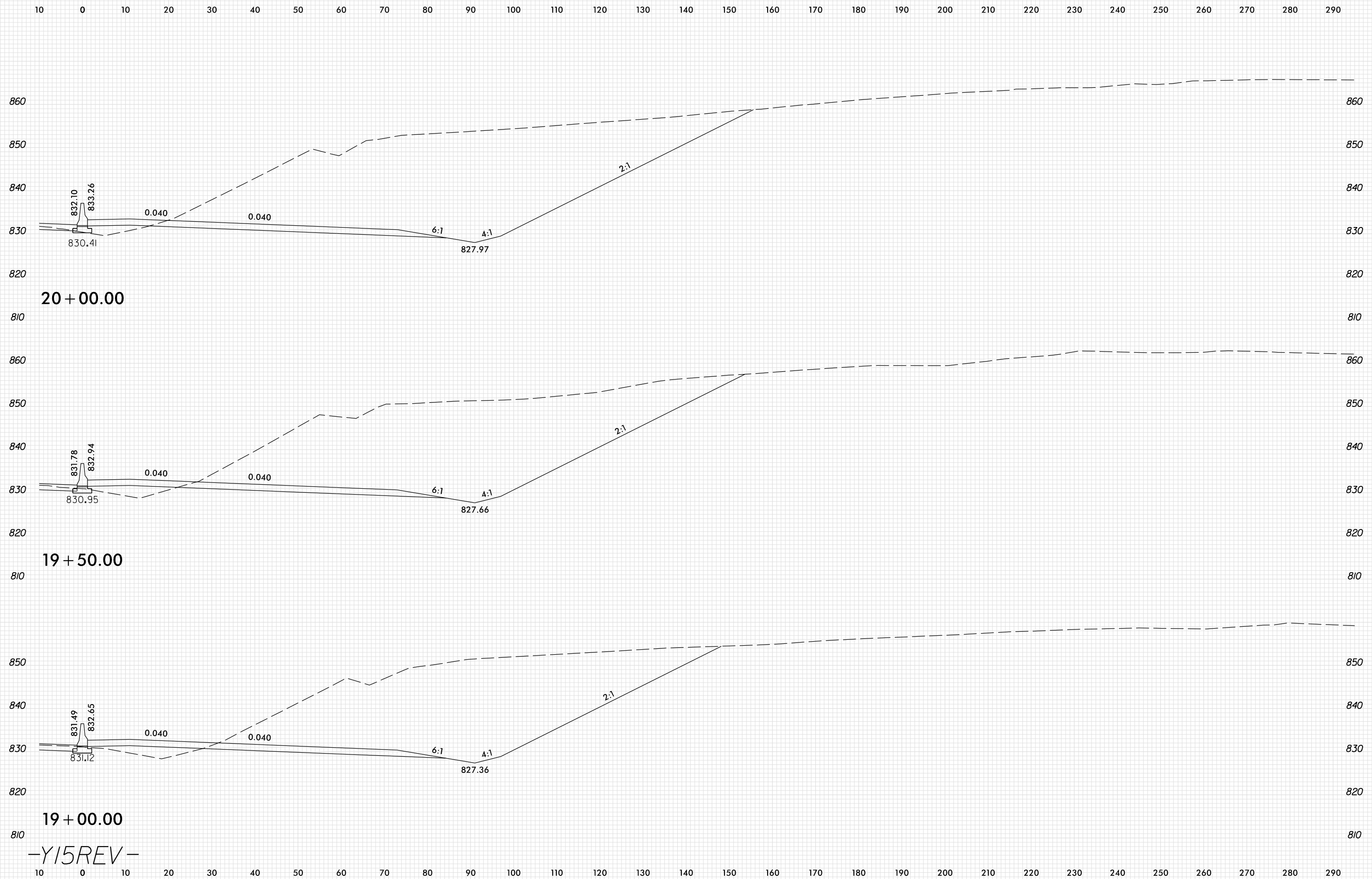

20 + 00.00

19 + 50.00

19 + 00.00

-Y15REV-

PLOT DRIVER: NCD01_pdf_color_eng_100.plt
 USER: SPEREIRA
 DATE: 6/10/2021
 TIME: 2:23:54 PM
 FILE: \

8/23/99

0 5 10	PROJ. REFERENCE NO.	SHEET NO.
	U-2579AB	X-328

10 0 10 20 30 40 50 60 70 80 90 100 110 120 130 140 150 160 170 180 190 200 210 220 230 240 250 260 270 280 290

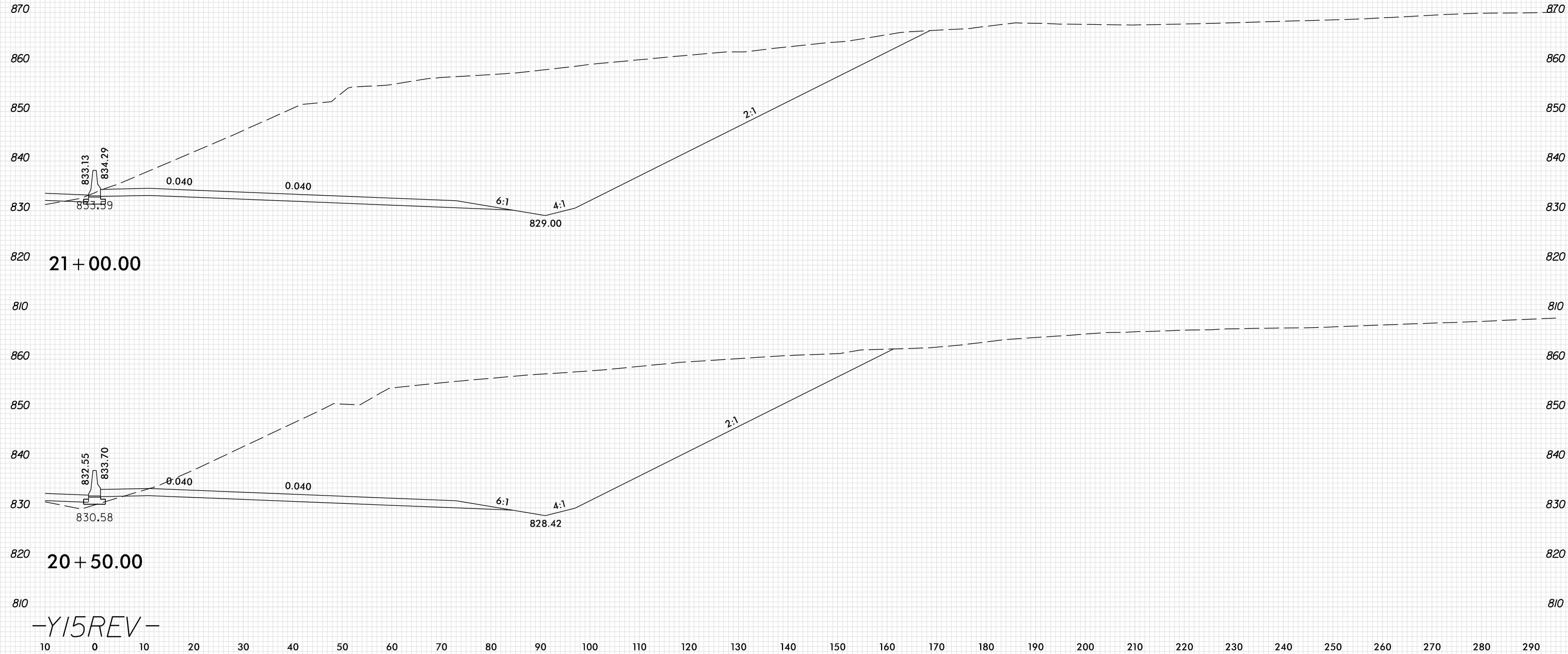

-Y15REV-

PLOT DRIVER: NCD01_pdf_color_eng_100.plt
 USER: SPEREIRA
 DATE: 6/10/2021
 TIME: 2:23:54 PM
 FILE: \

8/23/99

0 5 10	PROJ. REFERENCE NO.	SHEET NO.
	U-2579AB	X-329

10 0 10 20 30 40 50 60 70 80 90 100 110 120 130 140 150 160 170 180 190 200 210 220 230 240 250 260 270 280 290

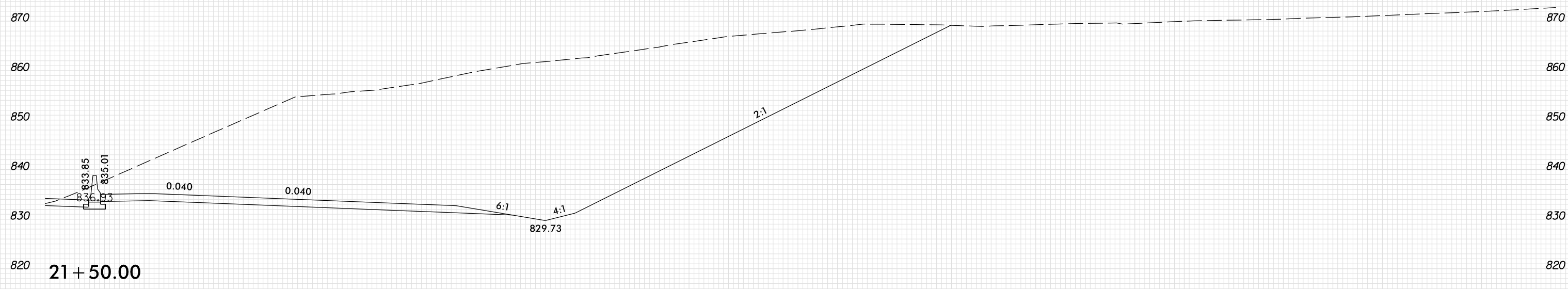
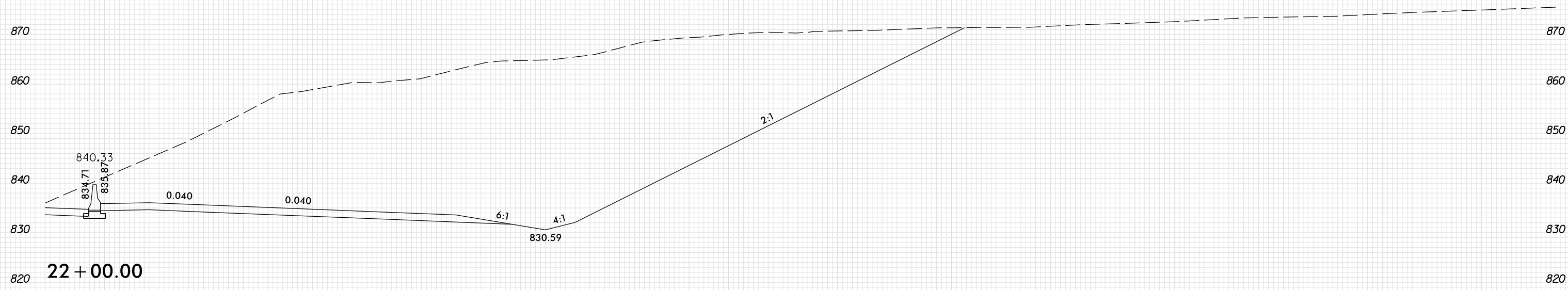

-Y15REV-

10 0 10 20 30 40 50 60 70 80 90 100 110 120 130 140 150 160 170 180 190 200 210 220 230 240 250 260 270 280 290

PLOT DRIVER: NCD01_pdf_color_eng_100.plt
 USER: SPEREIRA
 DATE: 6/10/2021
 TIME: 2:23:55 PM
 FILE: \

10 0 10 20 30 40 50 60 70 80 90 100 110 120 130 140 150 160 170 180 190 200 210 220 230 240 250 260 270 280 290

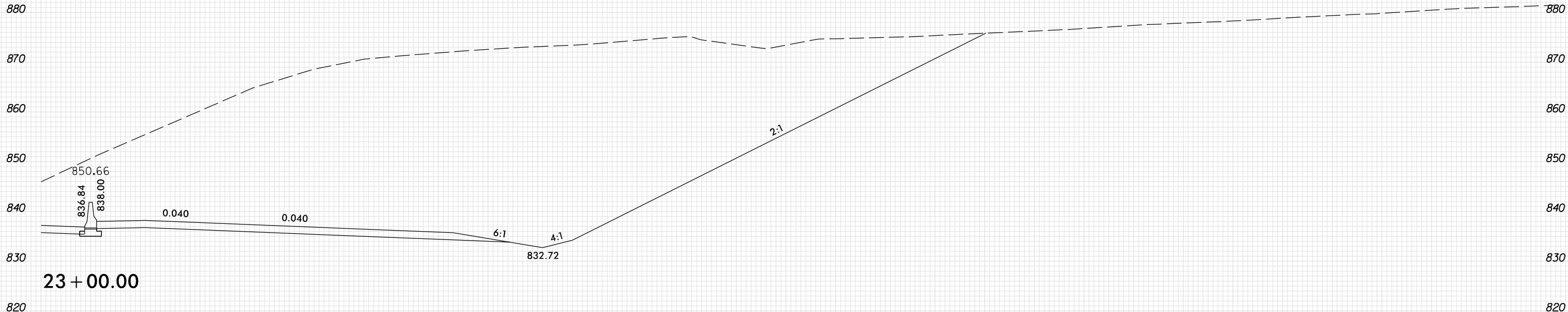

23 + 00.00

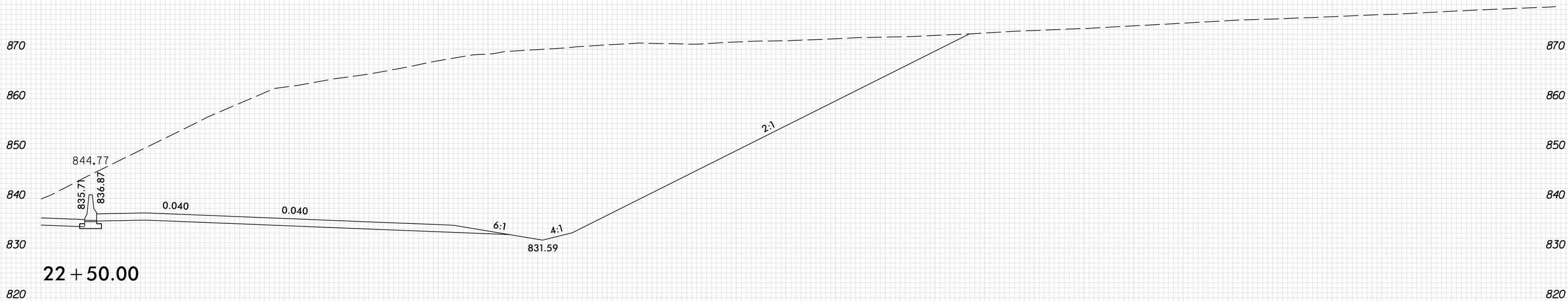

22 + 50.00

-Y15REV-

10 0 10 20 30 40 50 60 70 80 90 100 110 120 130 140 150 160 170 180 190 200 210 220 230 240 250 260 270 280 290

8/23/99

0 5 10	PROJ. REFERENCE NO.	SHEET NO.
	U-2579AB	X-331

10 0 10 20 30 40 50 60 70 80 90 100 110 120 130 140 150 160 170 180 190 200 210 220 230 240 250 260 270 280 290

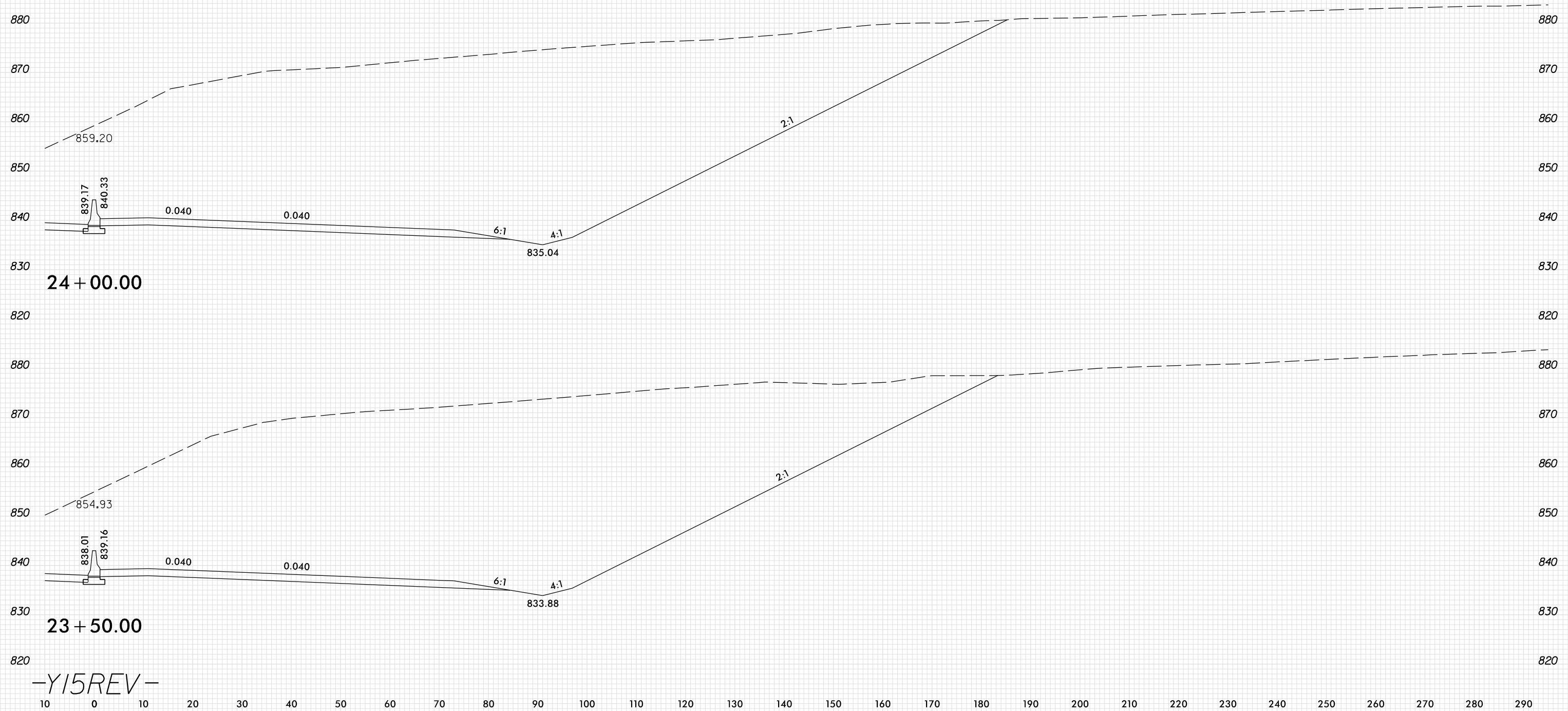

24 + 00.00

23 + 50.00

-Y15REV-

PLOT DRIVER: NCD01_pdf_color_eng_100.plt
 USER: SPEREIRA
 DATE: 6/10/2021
 TIME: 2:23:56 PM
 FILE: \

8/23/99

0 5 10	PROJ. REFERENCE NO.	SHEET NO.
	U-2579AB	X-332

10 0 10 20 30 40 50 60 70 80 90 100 110 120 130 140 150 160 170 180 190 200 210 220 230 240 250 260 270 280 290

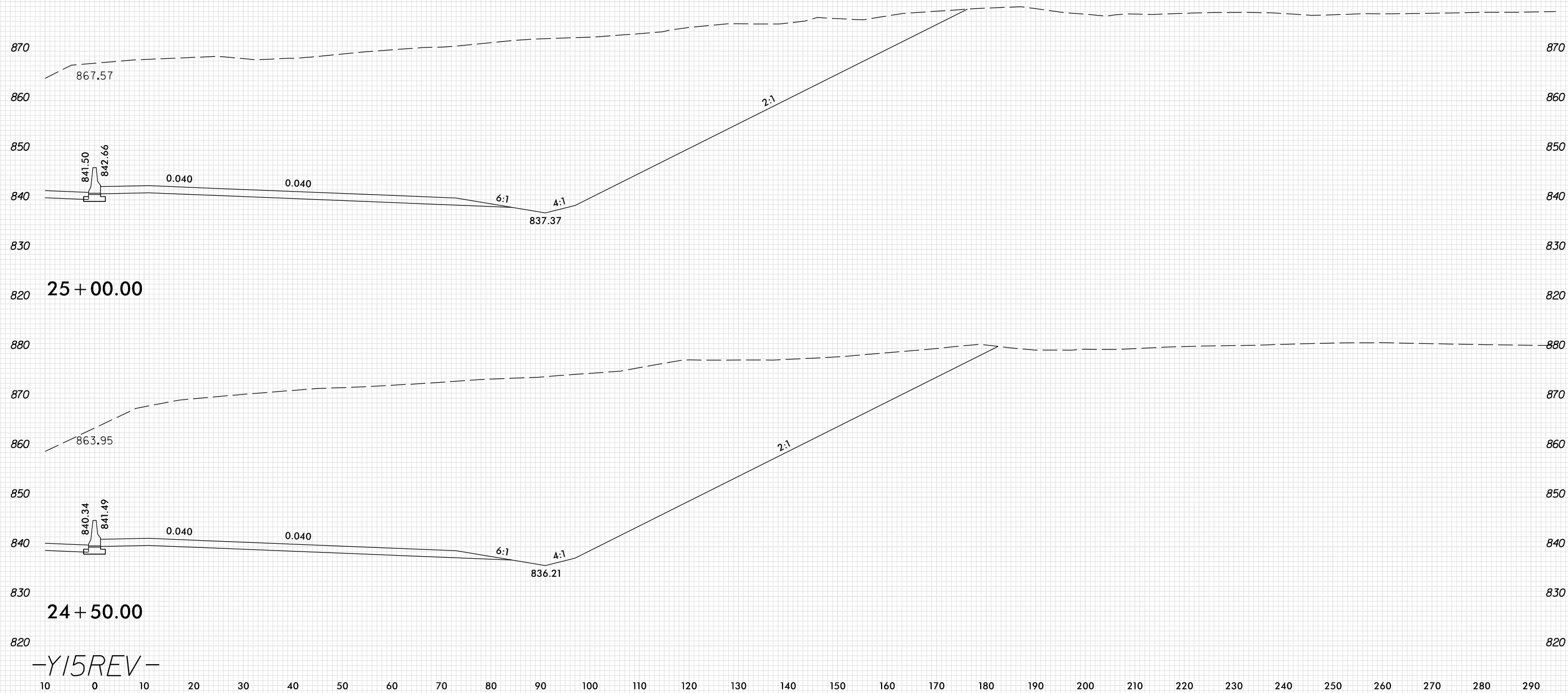

25 + 00.00

24 + 50.00

-Y15REV-

PLOT DRIVER: NCD01_.pdf_color_eng_100.plt
 USER: SPEREIRA
 DATE: 6/10/2021
 TIME: 2:23:57 PM
 FILE: \

8/23/99

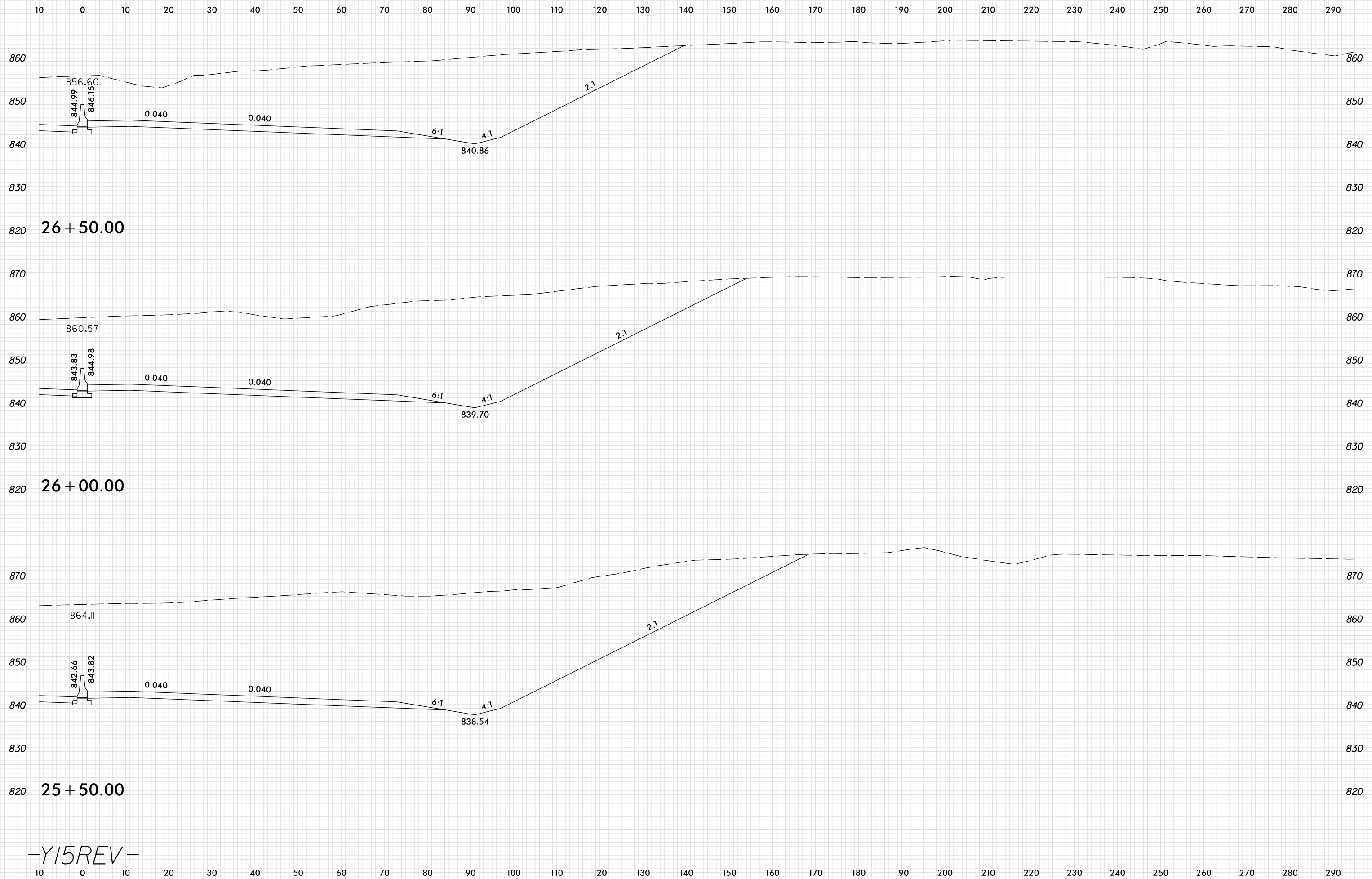

PLOT DRIVER: NCDOT_pdf_color_eng_100.plt
 USER: SPEREIRA
 DATE: 6/10/2021
 TIME: 2:23:57 PM
 FILE: \

-Y15REV-

8/23/99

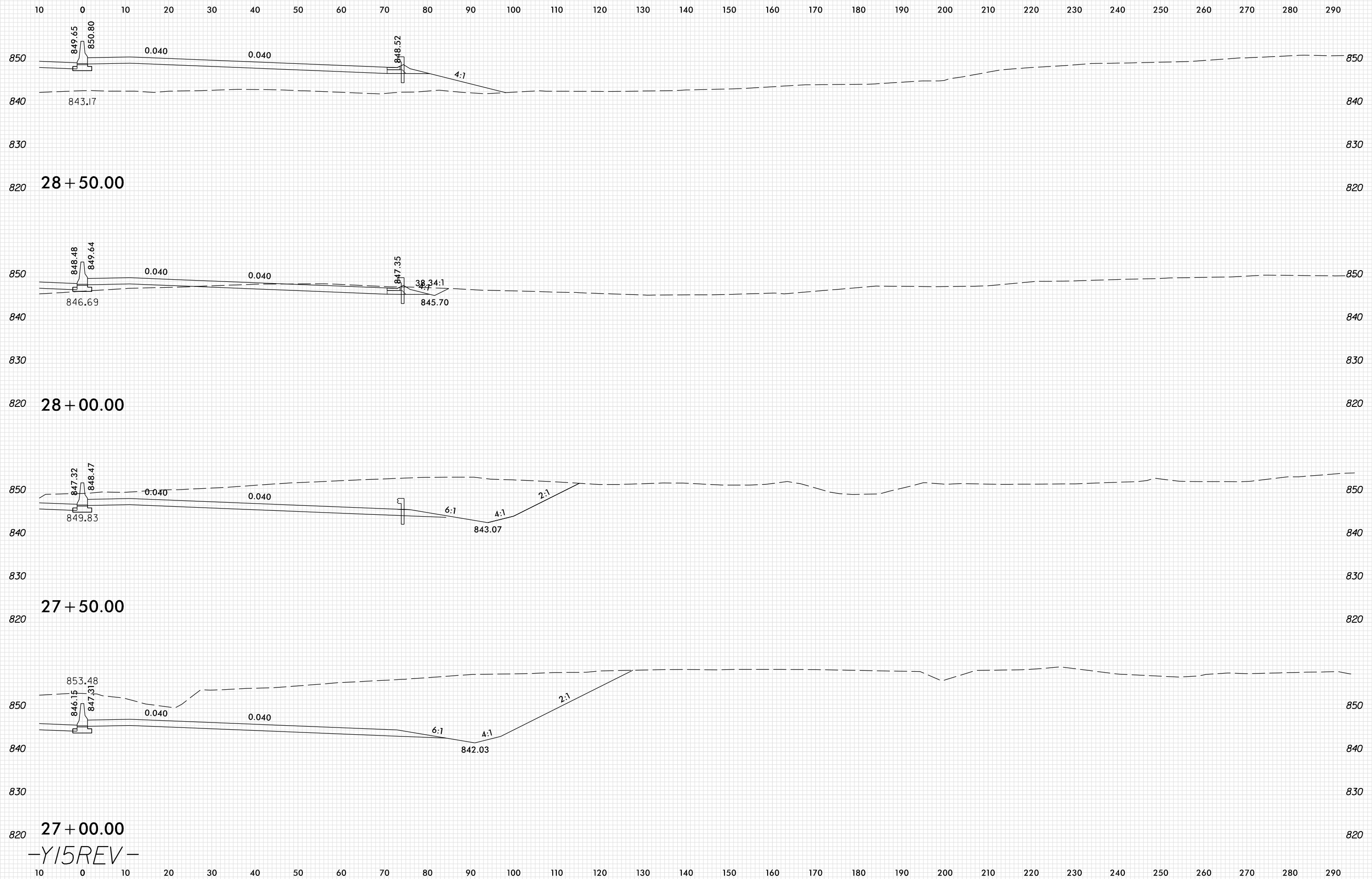

28 + 50.00

28 + 00.00

27 + 50.00

27 + 00.00

-Y15REV-

PLOT DRIVER: NCDOT_pdf_color_eng_100.plt
 USER: SPEREIRA
 DATE: 6/10/2021
 TIME: 2:23:58 PM
 FILE: \

8/23/99



PROJ. REFERENCE NO.	SHEET NO.
U-2579AB	X-335

10 0 10 20 30 40 50 60 70 80 90 100 110 120 130 140 150 160 170 180 190 200 210 220 230 240 250 260 270 280 290

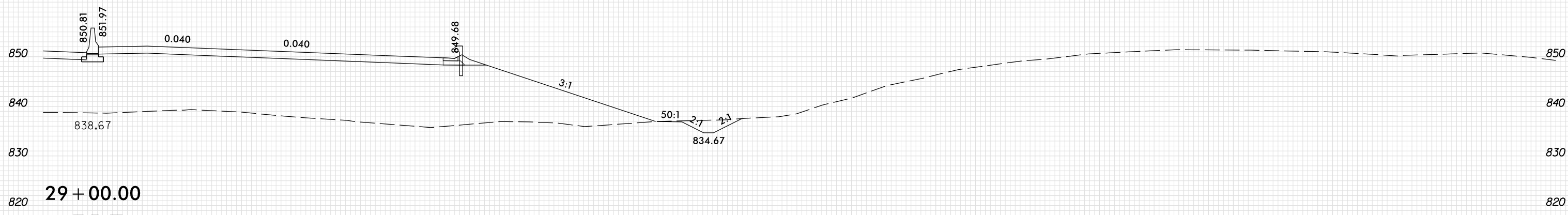
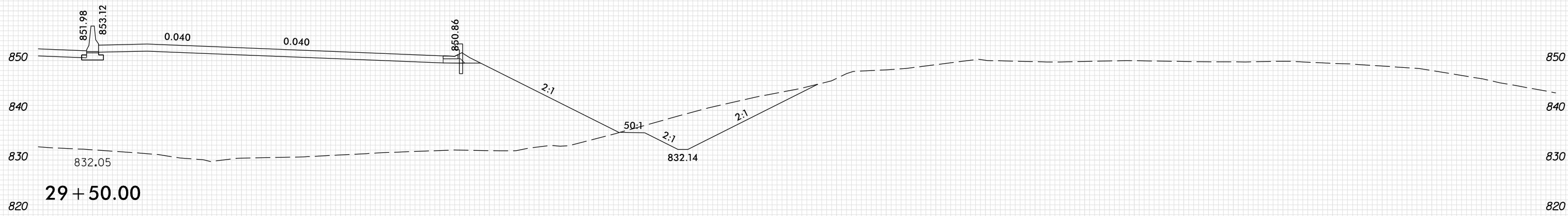
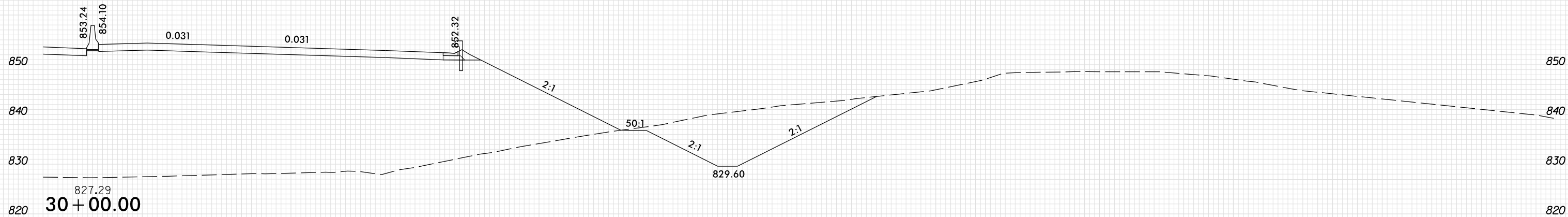

10 0 10 20 30 40 50 60 70 80 90 100 110 120 130 140 150 160 170 180 190 200 210 220 230 240 250 260 270 280 290

-Y15REV-

PLOT DRIVER: NCDOT_pdf_color_eng_100.plt
 USER: SPEREIRA
 DATE: 6/10/2021
 TIME: 2:23:59 PM
 FILE: \

8/23/99

10 0 10 20 30 40 50 60 70 80 90 100 110 120 130 140 150 160 170 180 190 200 210 220 230 240 250 260 270 280 290

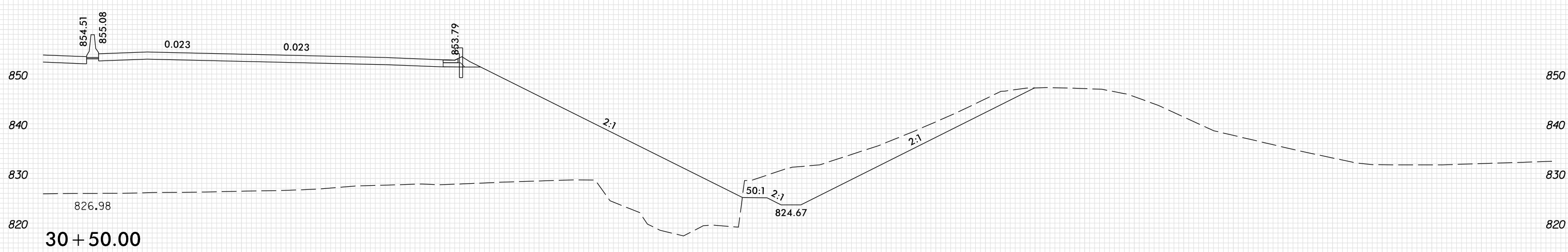
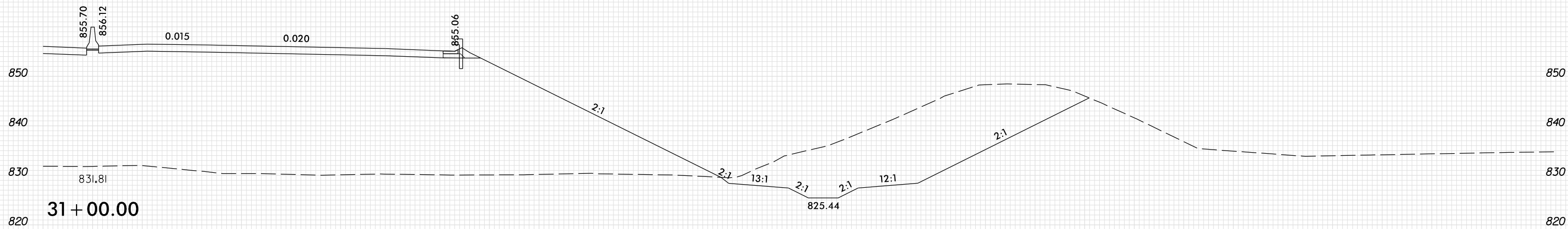
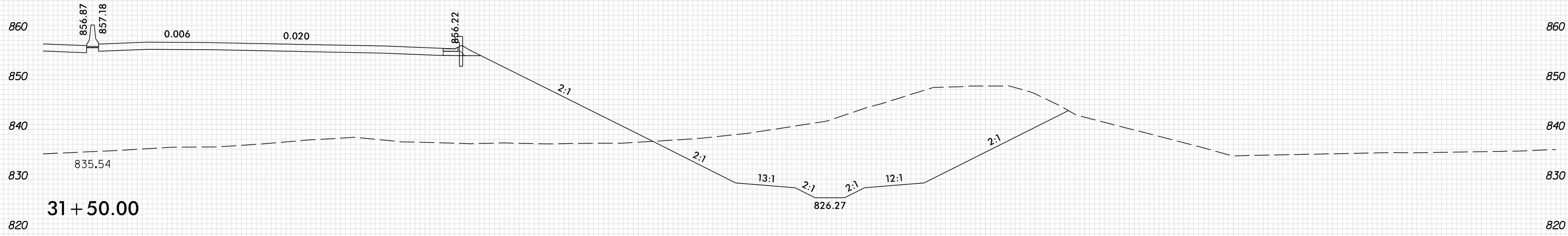

10 0 10 20 30 40 50 60 70 80 90 100 110 120 130 140 150 160 170 180 190 200 210 220 230 240 250 260 270 280 290

-Y15REV-

PLOT DRIVER: NCDOT_pdf_color_eng_100.plt
USER: SPEREIRA
DATE: 6/10/2021
TIME: 2:23:59 PM
FILE: \

8/23/99

10 0 10 20 30 40 50 60 70 80 90 100 110 120 130 140 150 160 170 180 190 200 210 220 230 240 250 260 270 280 290

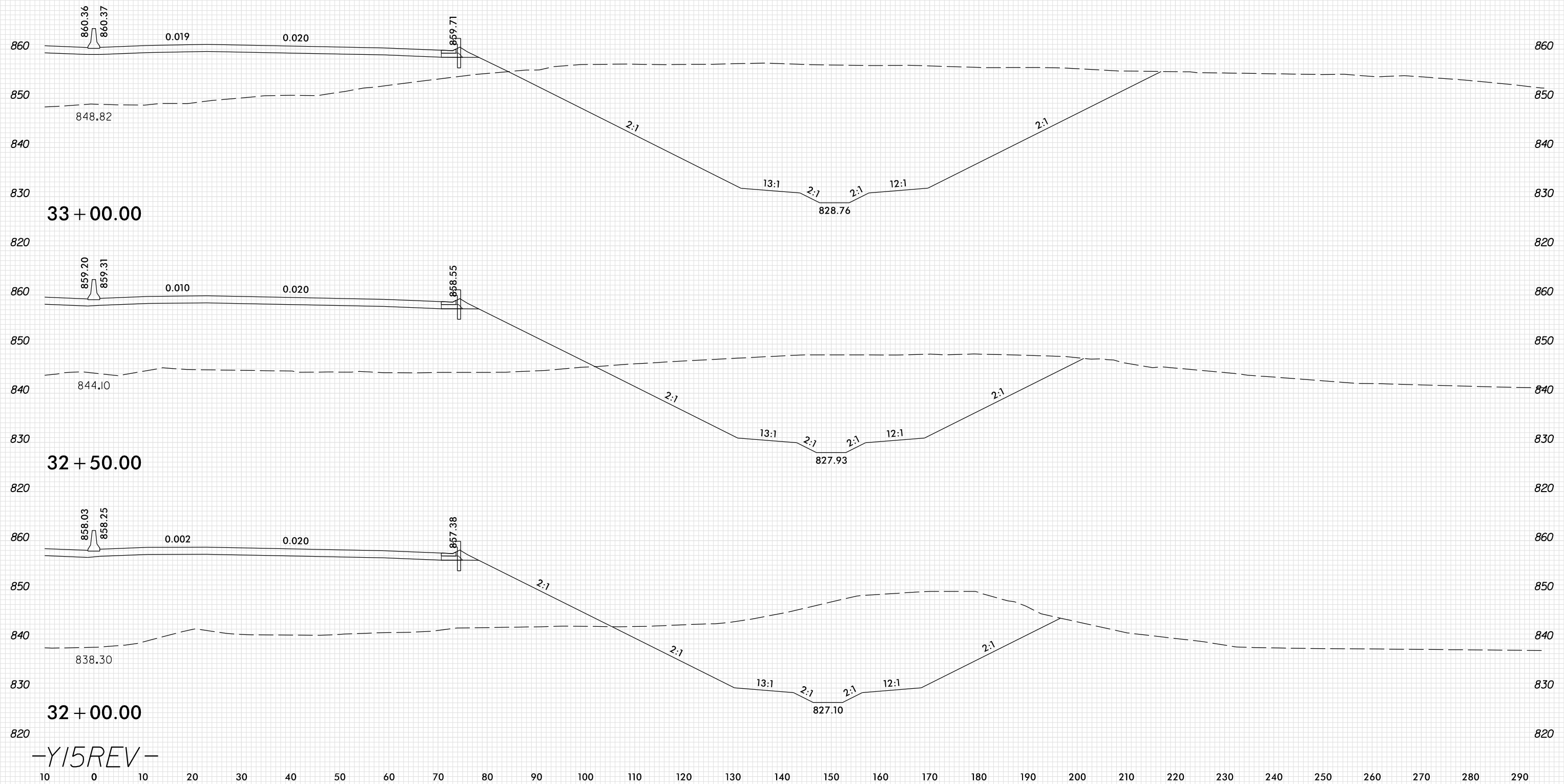

PLOT DRIVER: NCD01_pdf_color_eng_100.plt
USER: SPEREIRA
DATE: 6/10/2021
TIME: 2:24:00 PM
FILE: \

33 + 00.00

32 + 50.00

32 + 00.00

-Y15REV-

8/23/99

0 5 10	PROJ. REFERENCE NO.	SHEET NO.
	U-2579AB	X-338

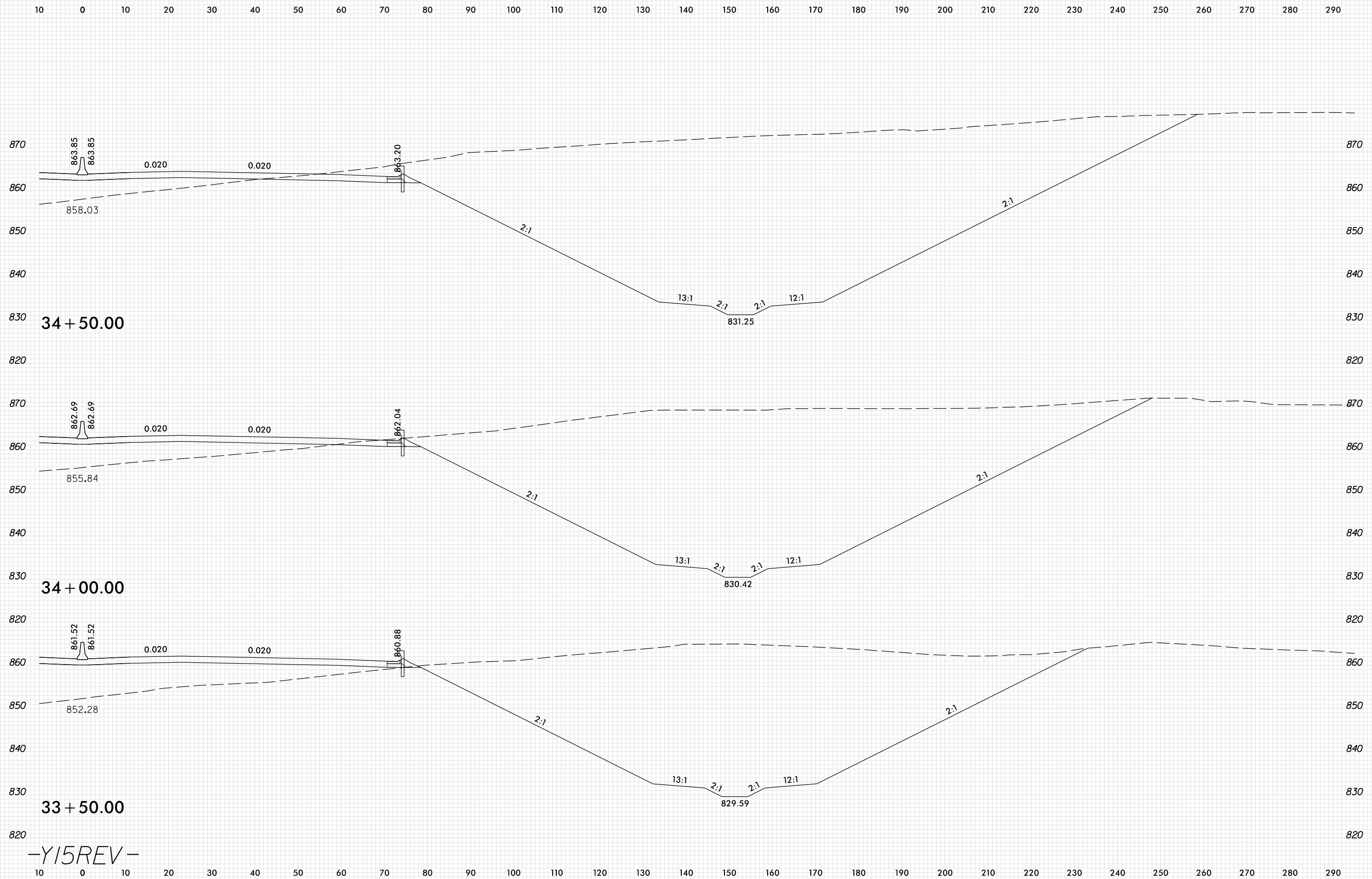

PLOT DRIVER: NCD01_pdf_color_eng_100.plt
 USER: SPEREIRA
 DATE: 6/10/2021
 TIME: 2:24:01 PM
 FILE: \

-Y15REV-

8/23/99

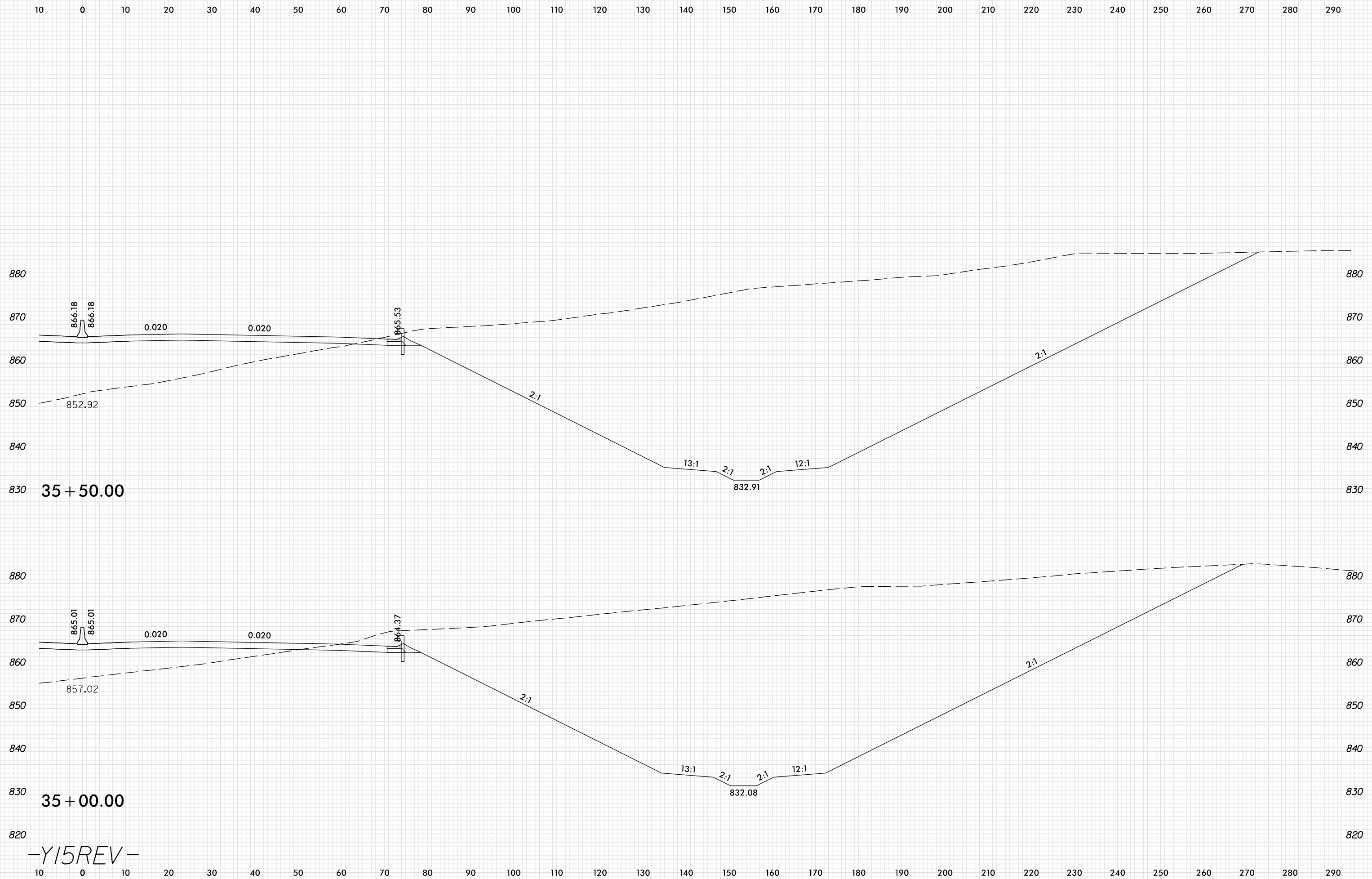

PLOT DRIVER: NCD01_pdf_color_eng_100.plt
 USER: SPEREIRA
 DATE: 6/10/2021
 TIME: 2:24:01 PM
 FILE: \

-Y15REV-

8/23/99

10 0 10 20 30 40 50 60 70 80 90 100 110 120 130 140 150 160 170 180 190 200 210 220 230 240 250 260 270 280 290

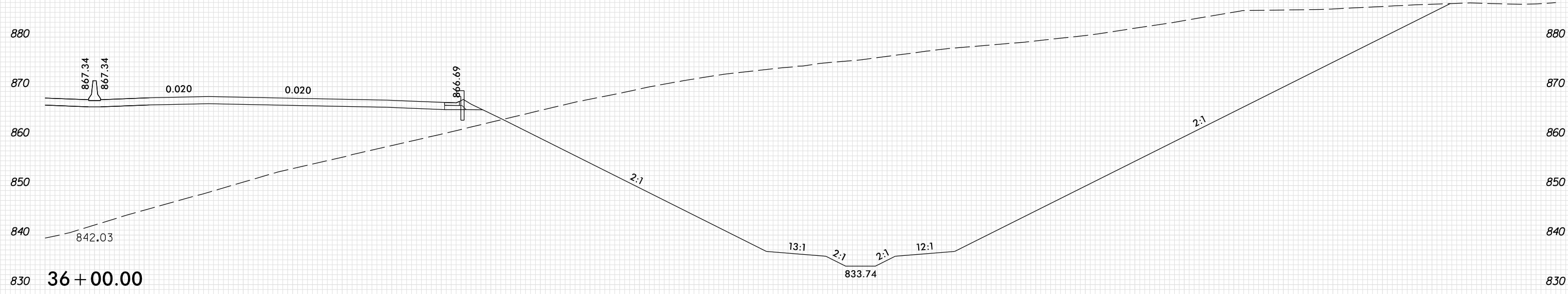
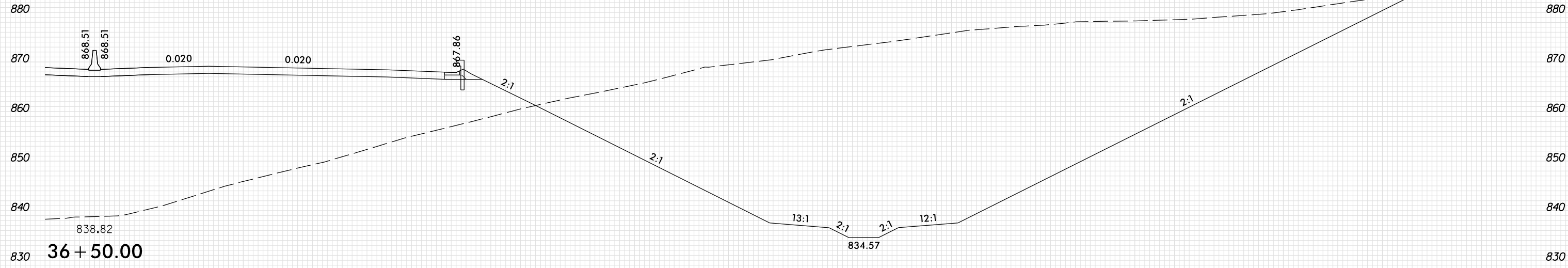

-Y15REV-

10 0 10 20 30 40 50 60 70 80 90 100 110 120 130 140 150 160 170 180 190 200 210 220 230 240 250 260 270 280 290

PLOT DRIVER: NCDOT_pdf_color_eng_100.plt
USER: SPEREIRA
DATE: 6/10/2021
TIME: 2:24:02 PM
FILE: \

8/23/99

0 5 10	PROJ. REFERENCE NO.	SHEET NO.
	U-2579AB	X-341

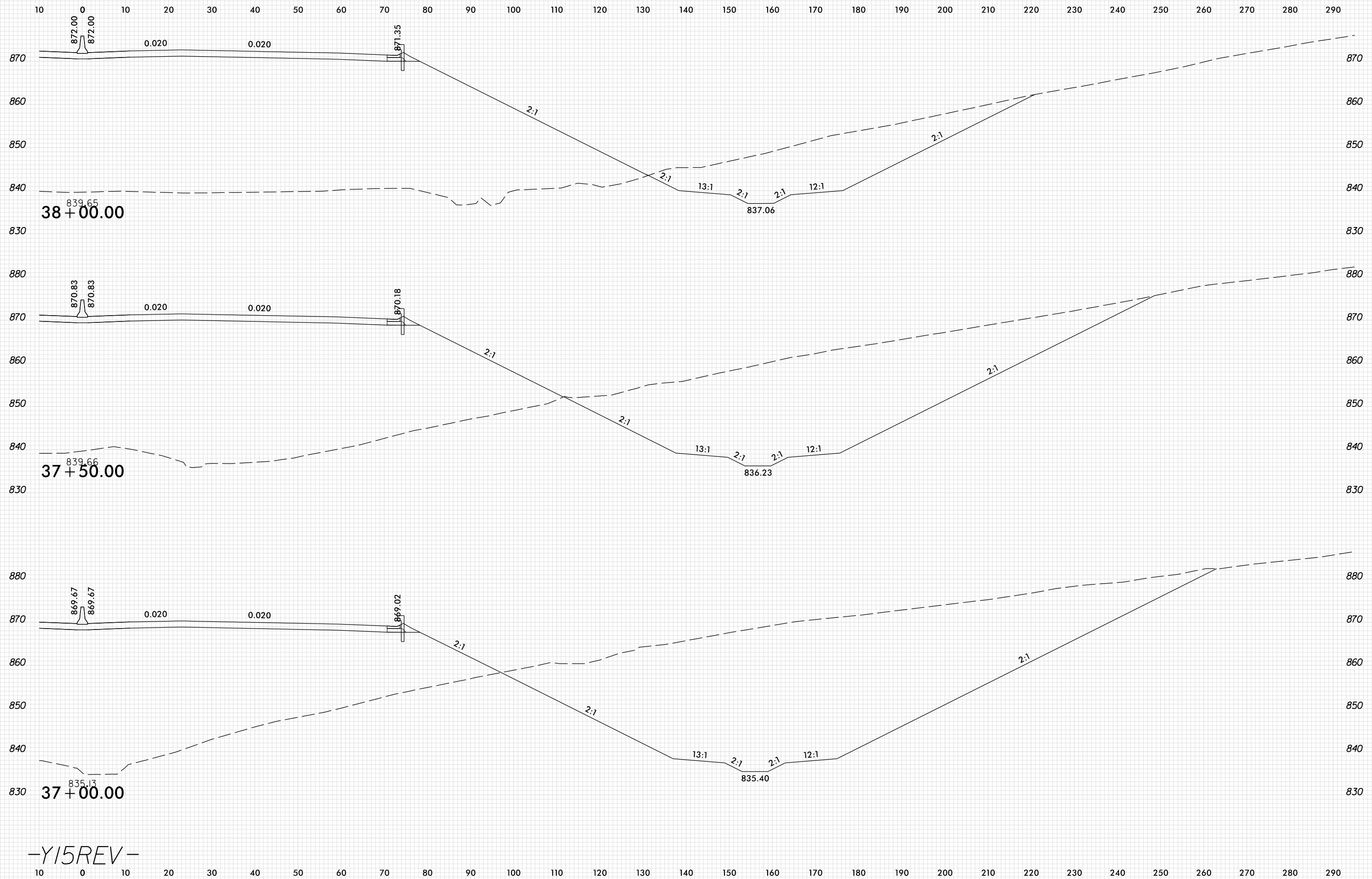

PLOT DRIVER: NCD01_pdf_color_eng_100.plt
 USER: SPEREIRA
 DATE: 6/10/2021
 TIME: 2:24:02 PM

-Y15REV-

8/23/99



PROJ. REFERENCE NO.	SHEET NO.
U-2579AB	X-342

10 0 10 20 30 40 50 60 70 80 90 100 110 120 130 140 150 160 170 180 190 200 210 220 230 240 250 260 270 280 290

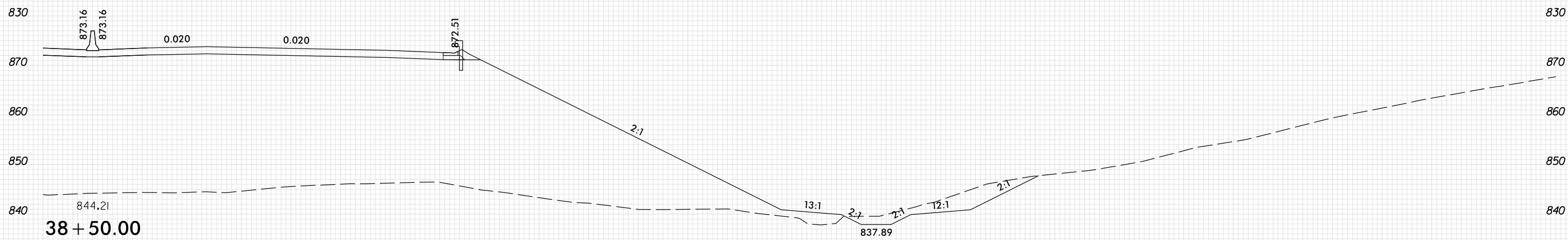
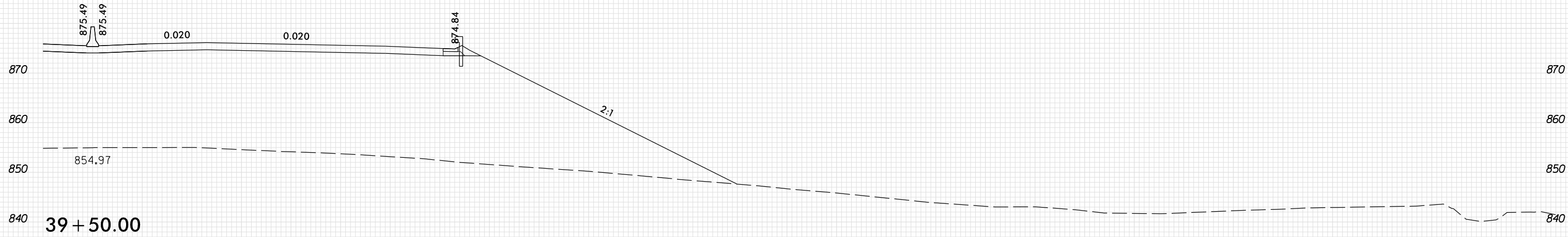

10 0 10 20 30 40 50 60 70 80 90 100 110 120 130 140 150 160 170 180 190 200 210 220 230 240 250 260 270 280 290

-Y15REV-

PLOT DRIVER: NCD01_pdf_color_eng_100.plt
 USER: SPEREIRA
 DATE: 6/10/2021
 TIME: 2:24:03 PM
 FILE: \

8/23/99

10 0 10 20 30 40 50 60 70 80 90 100 110 120 130 140 150 160 170 180 190 200 210 220 230 240 250 260 270 280 290

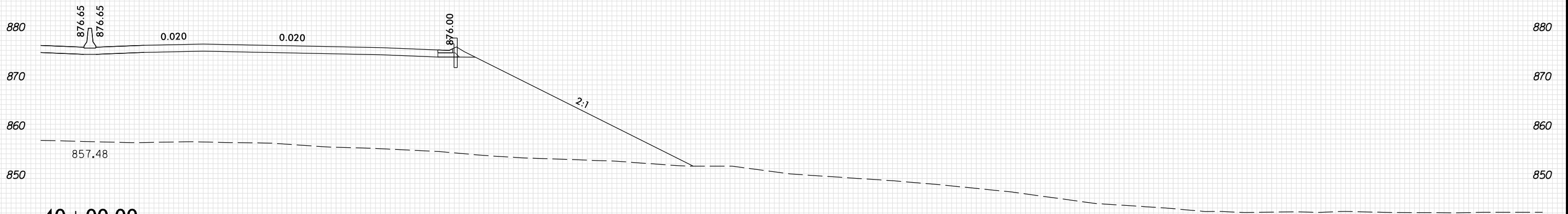

40 + 00.00
-Y15REV-

10 0 10 20 30 40 50 60 70 80 90 100 110 120 130 140 150 160 170 180 190 200 210 220 230 240 250 260 270 280 290

PLOT DRIVER: NCDOT_pdf_color_eng_100.plt
USER: SPEREIRA
DATE: 6/10/2021
TIME: 2:24:04 PM
FILE: \

8/23/99

10 0 10 20 30 40 50 60 70 80 90 100 110 120 130 140 150 160 170 180 190 200 210 220 230 240 250 260 270 280 290

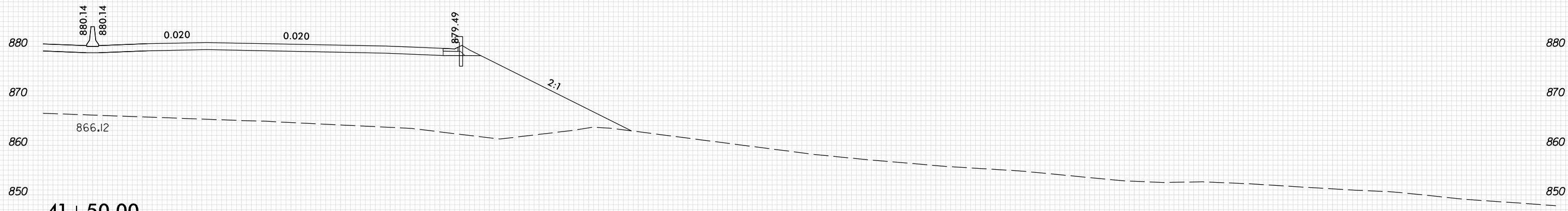
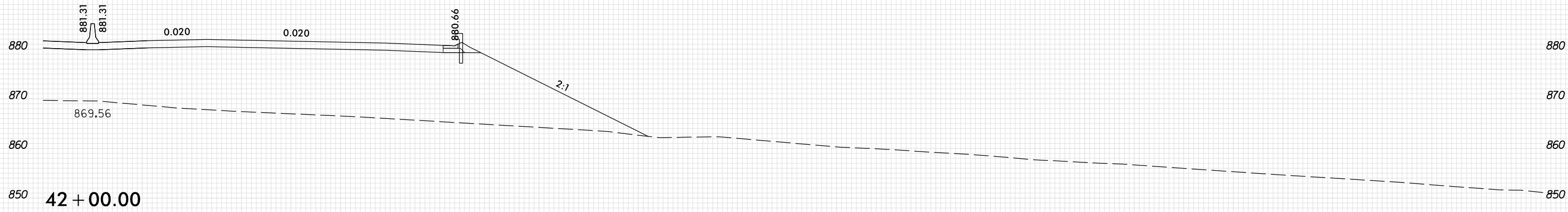
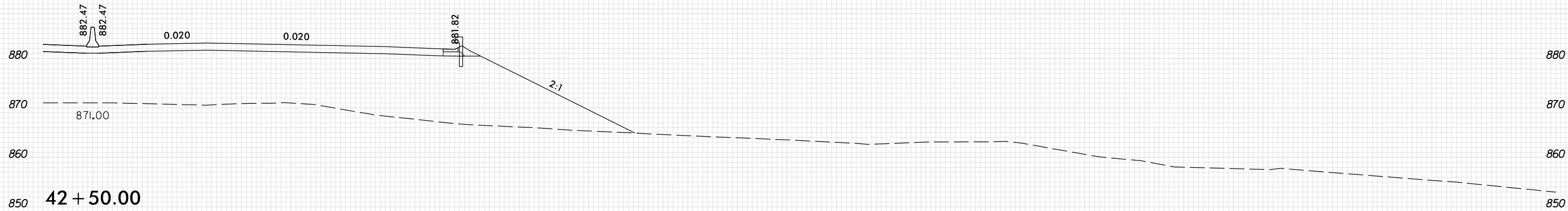

-Y15REV-

10 0 10 20 30 40 50 60 70 80 90 100 110 120 130 140 150 160 170 180 190 200 210 220 230 240 250 260 270 280 290

8/23/99

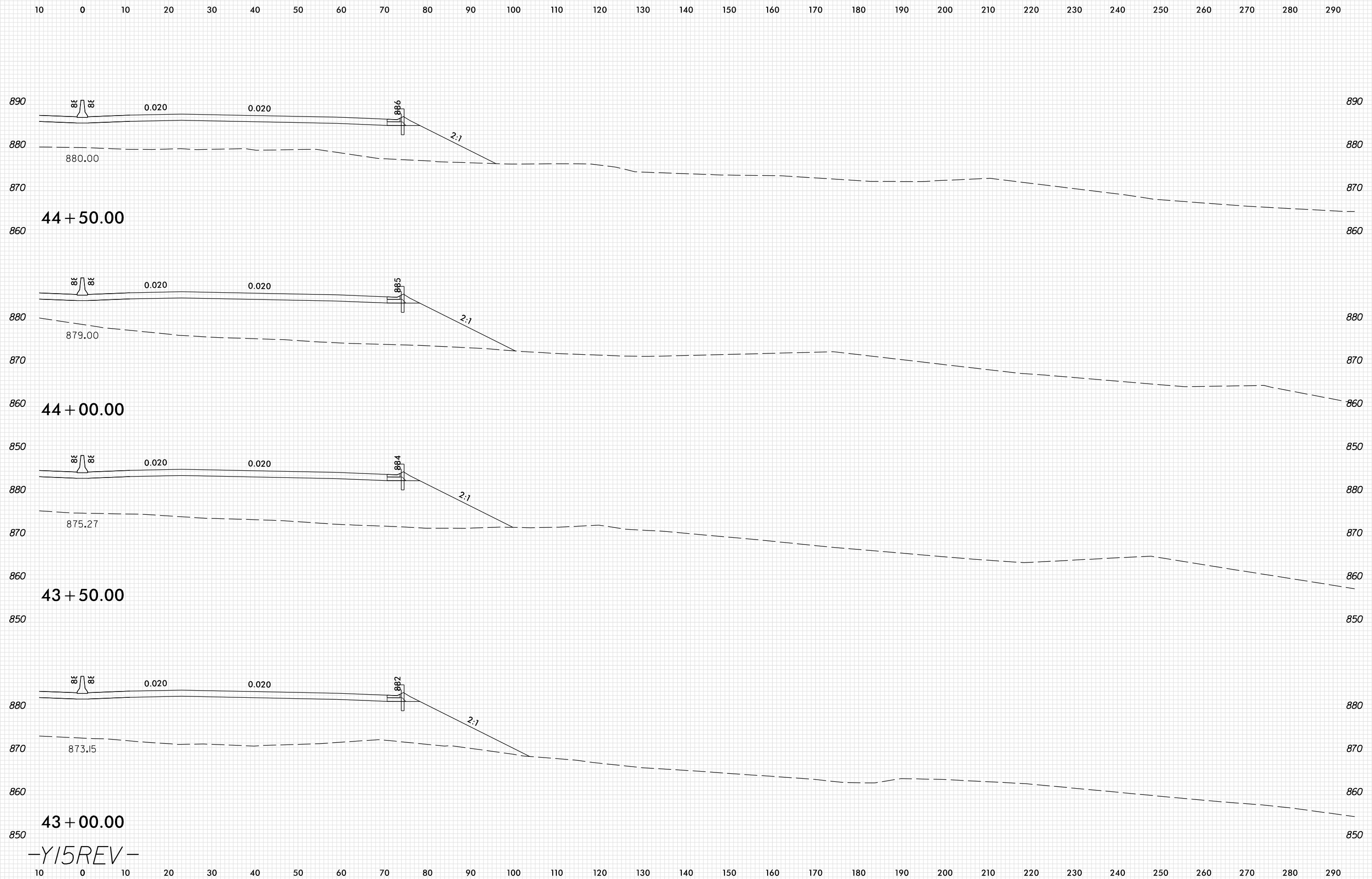

PLOT DRIVER: NCD01_pdf_color_eng_100.plt
 USER: SPEREIRA
 DATE: 6/10/2021
 TIME: 2:24:05 PM
 FILE: \

-Y15REV-

10 0 10 20 30 40 50 60 70 80 90 100 110 120 130 140 150 160 170 180 190 200 210 220 230 240 250 260 270 280 290

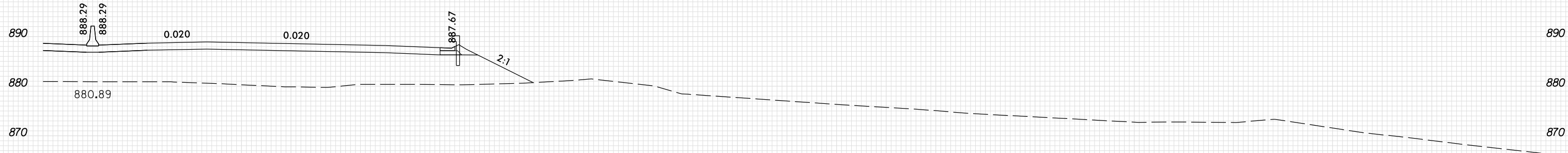
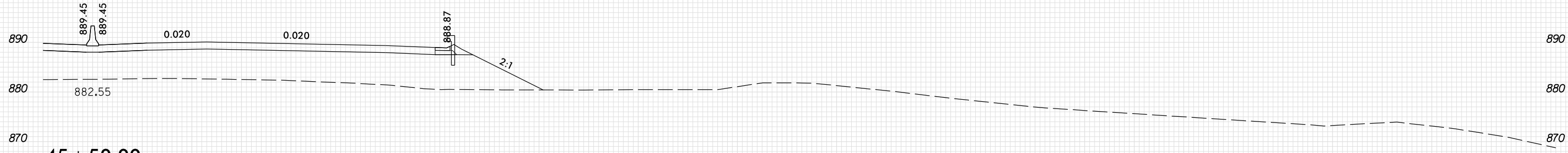
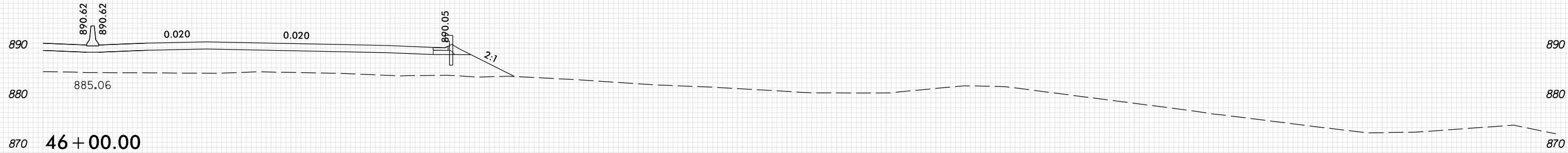
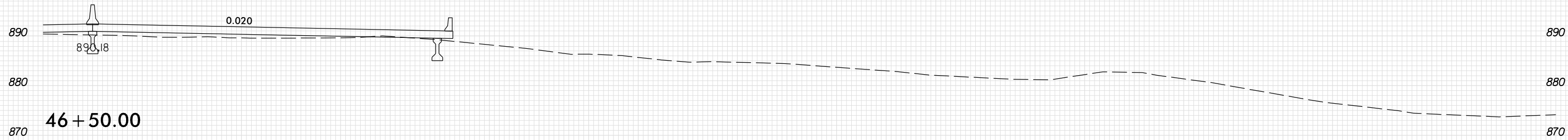

-Y15REV-

10 0 10 20 30 40 50 60 70 80 90 100 110 120 130 140 150 160 170 180 190 200 210 220 230 240 250 260 270 280 290

8/23/99

0 5 10	PROJ. REFERENCE NO.	SHEET NO.
	U-2579AB	X-347

10 0 10 20 30 40 50 60 70 80 90 100 110 120 130 140 150 160 170 180 190 200 210 220 230 240 250 260 270 280 290

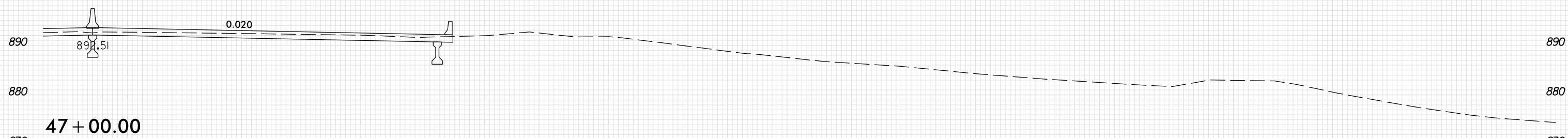
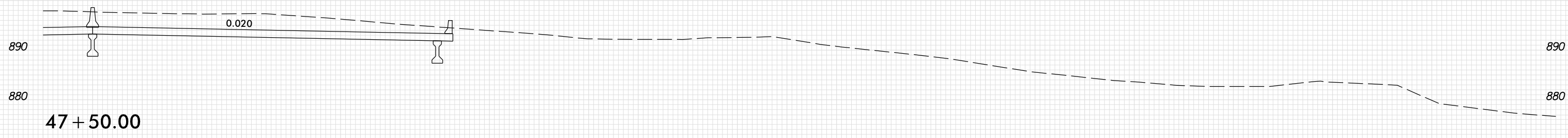
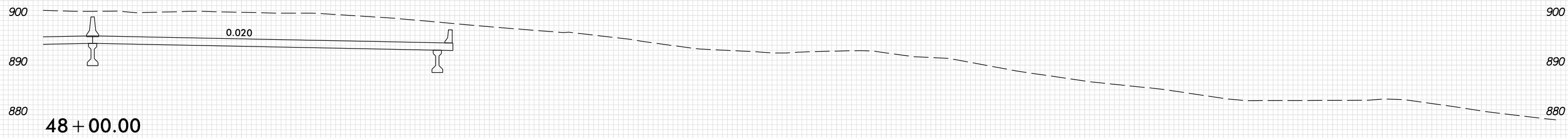
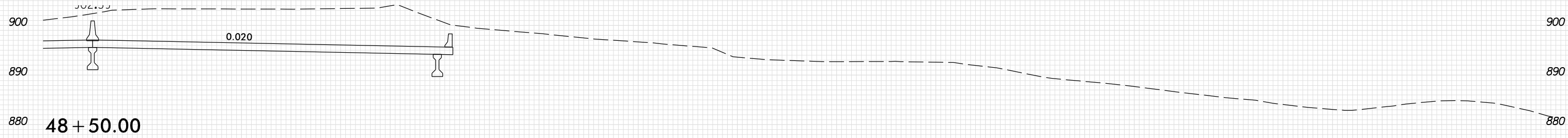

10 0 10 20 30 40 50 60 70 80 90 100 110 120 130 140 150 160 170 180 190 200 210 220 230 240 250 260 270 280 290

-Y15REV-

PLOT DRIVER: NCD01...pdf_color_eng_100.plt
USER: SPEREIRA
DATE: 6/10/2021
TIME: 2:24:06 PM

8/23/99

10 0 10 20 30 40 50 60 70 80 90 100 110 120 130 140 150 160 170 180 190 200 210 220 230 240 250 260 270 280 290

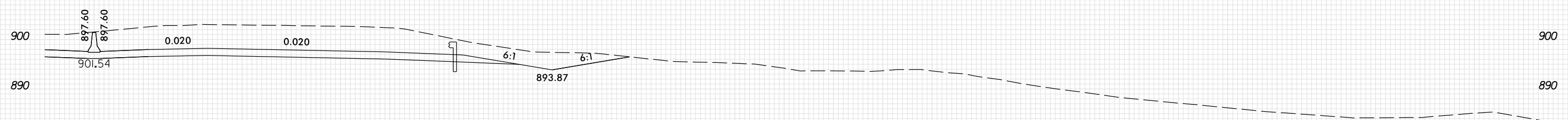
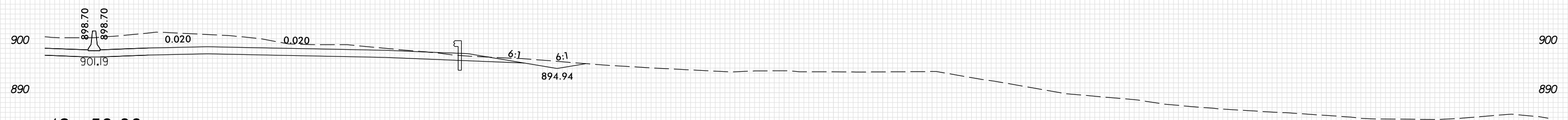
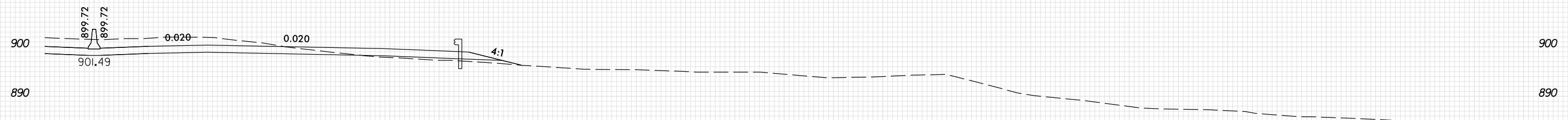
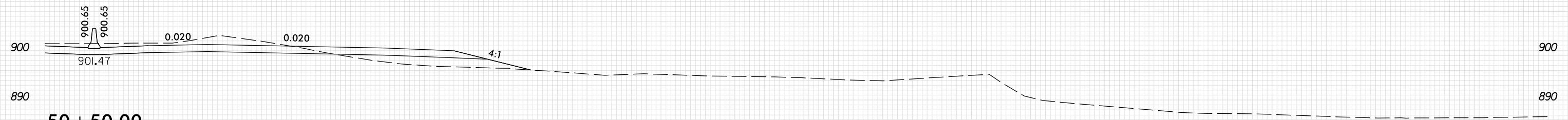
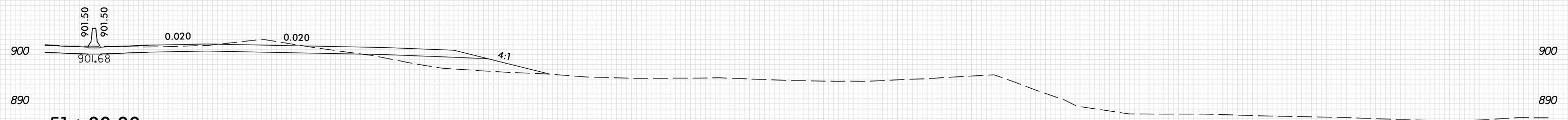

880 49+00.00
-Y15REV-

10 0 10 20 30 40 50 60 70 80 90 100 110 120 130 140 150 160 170 180 190 200 210 220 230 240 250 260 270 280 290

PLOT DRIVER: NCDOT_pdf_color_eng_100.plt
USER: SPEREIRA
DATE: 6/10/2021
TIME: 2:24:07 PM
FILE: \

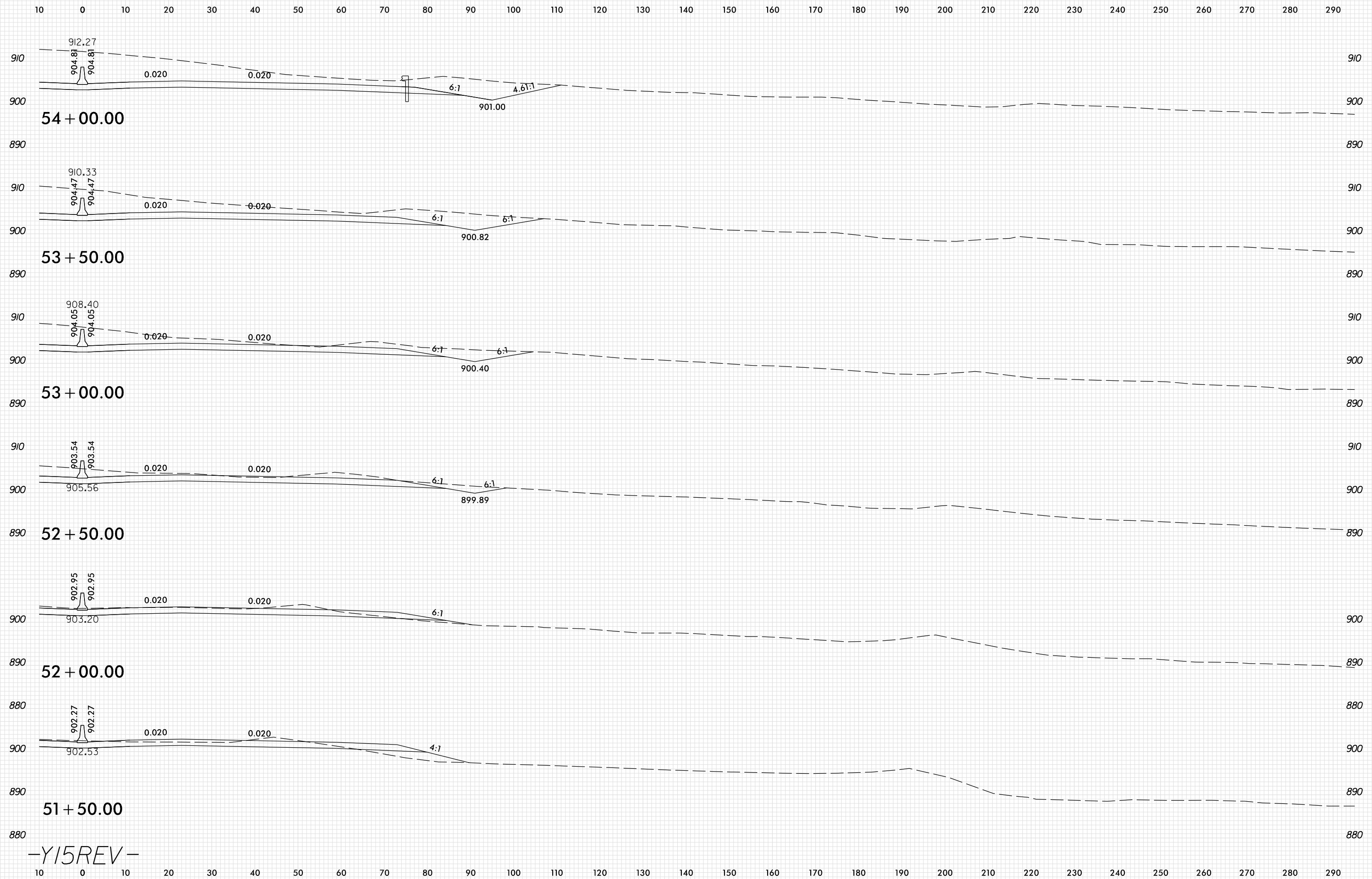

PLOT DRIVER: NCDOT_pdf_color_eng_100.plt
 USER: SPEREIRA
 DATE: 6/10/2021
 TIME: 2:24:07 PM
 FILE: \

-Y15REV-

8/23/99

10 0 10 20 30 40 50 60 70 80 90 100 110 120 130 140 150 160 170 180 190 200 210 220 230 240 250 260 270 280 290

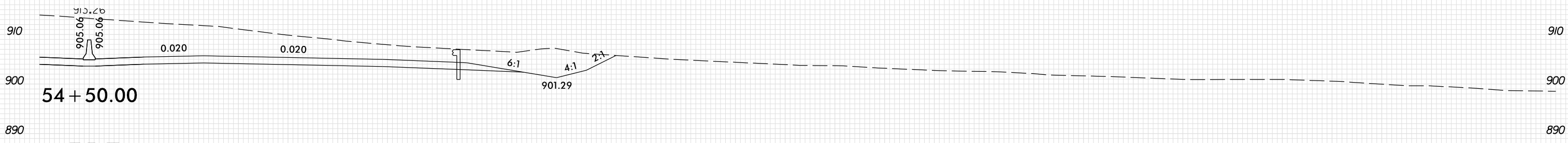
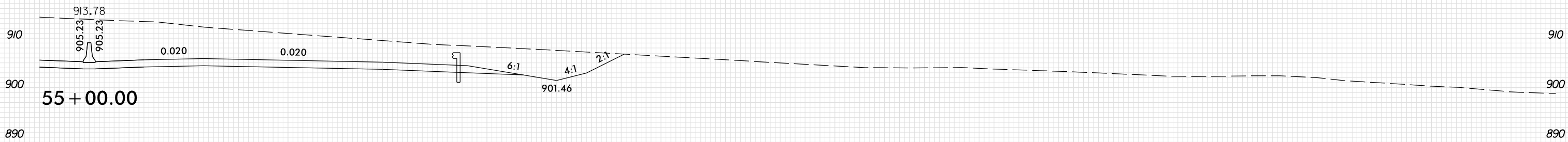
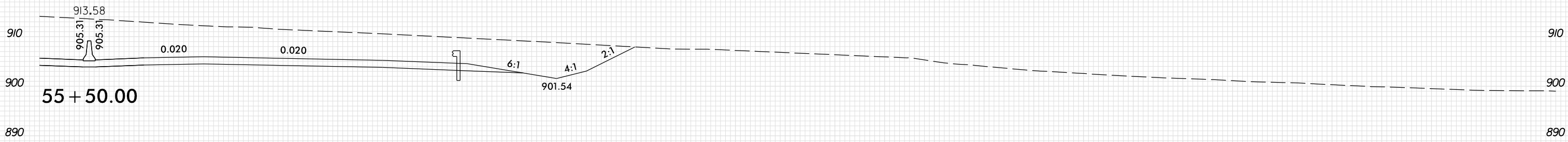
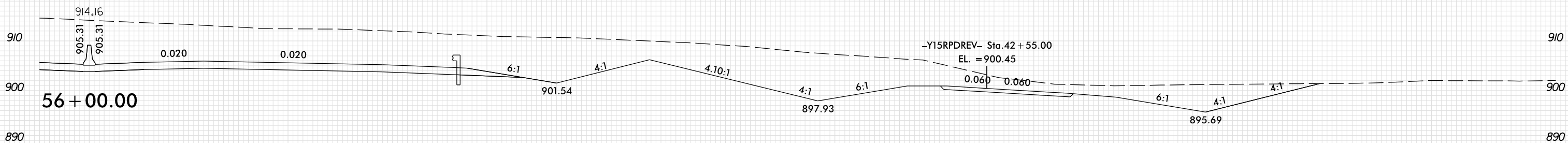
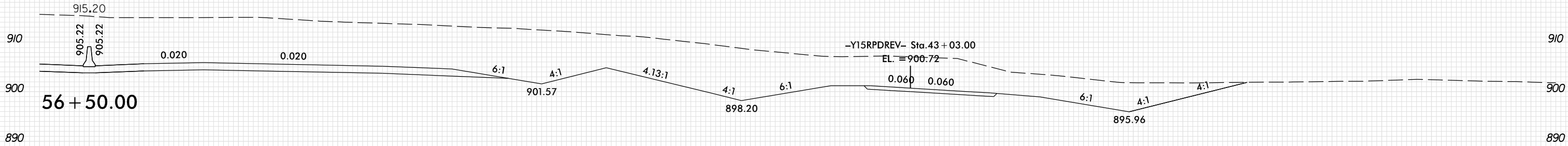

-Y15REV-

10 0 10 20 30 40 50 60 70 80 90 100 110 120 130 140 150 160 170 180 190 200 210 220 230 240 250 260 270 280 290

PLOT DRIVER: NCDOT_pdf_color_eng_100.plt
USER: SPEREIRA
DATE: 6/10/2021
TIME: 2:24:08 PM
FILE: \

10 0 10 20 30 40 50 60 70 80 90 100 110 120 130 140 150 160 170 180 190 200 210 220 230 240 250 260 270 280 290

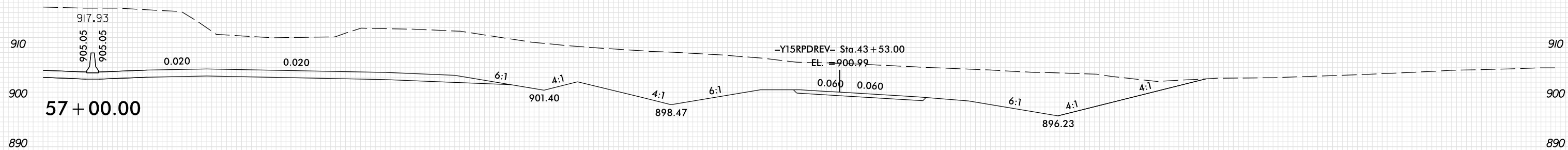
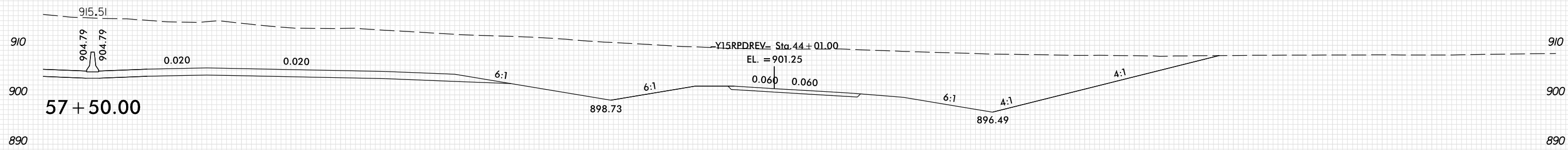
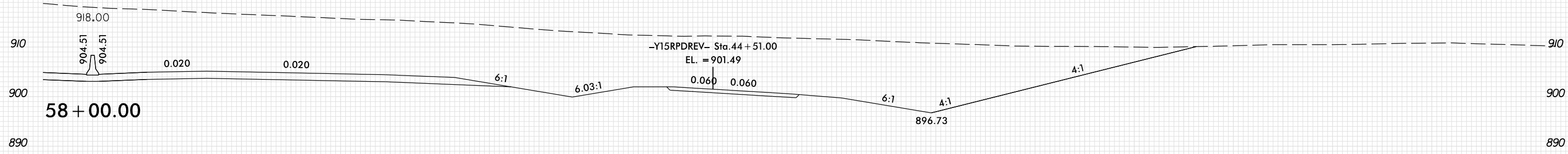
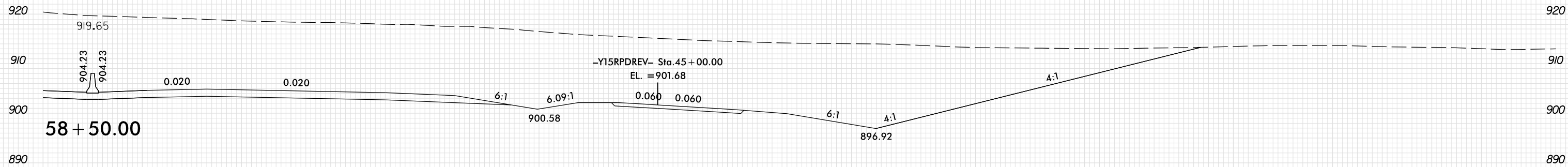

57+00.00
-Y15REV-

10 0 10 20 30 40 50 60 70 80 90 100 110 120 130 140 150 160 170 180 190 200 210 220 230 240 250 260 270 280 290

8/23/99



PROJ. REFERENCE NO.	SHEET NO.
U-2579AB	X-352

10 0 10 20 30 40 50 60 70 80 90 100 110 120 130 140 150 160 170 180 190 200 210 220 230 240 250 260 270 280 290

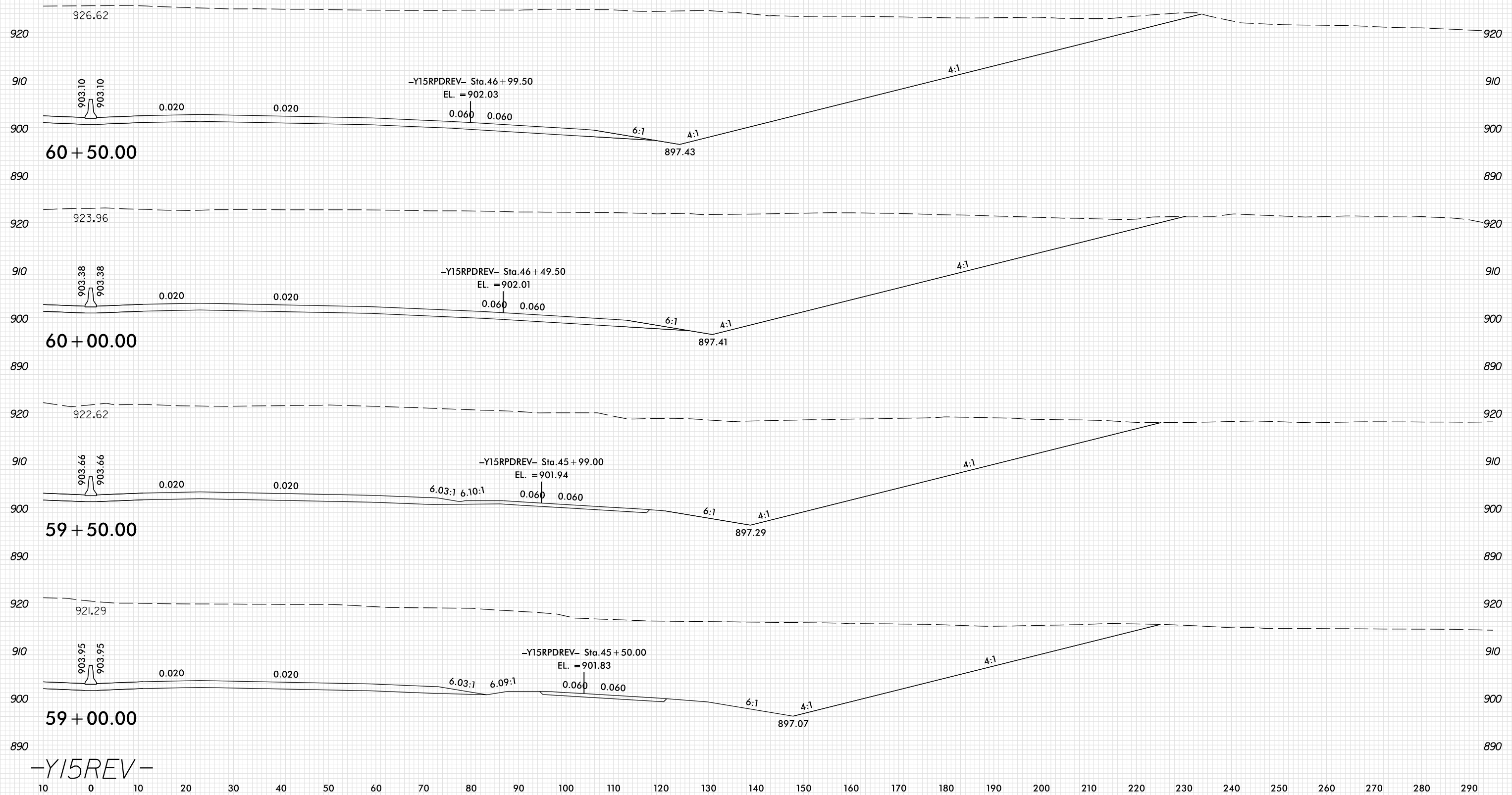

PLOT DRIVER: NCD01_pdf_color_eng_100.plt
 USER: SPEREIRA
 DATE: 6/10/2021
 TIME: 2:24:09 PM
 FILE: \

-Y15REV-

8/23/99

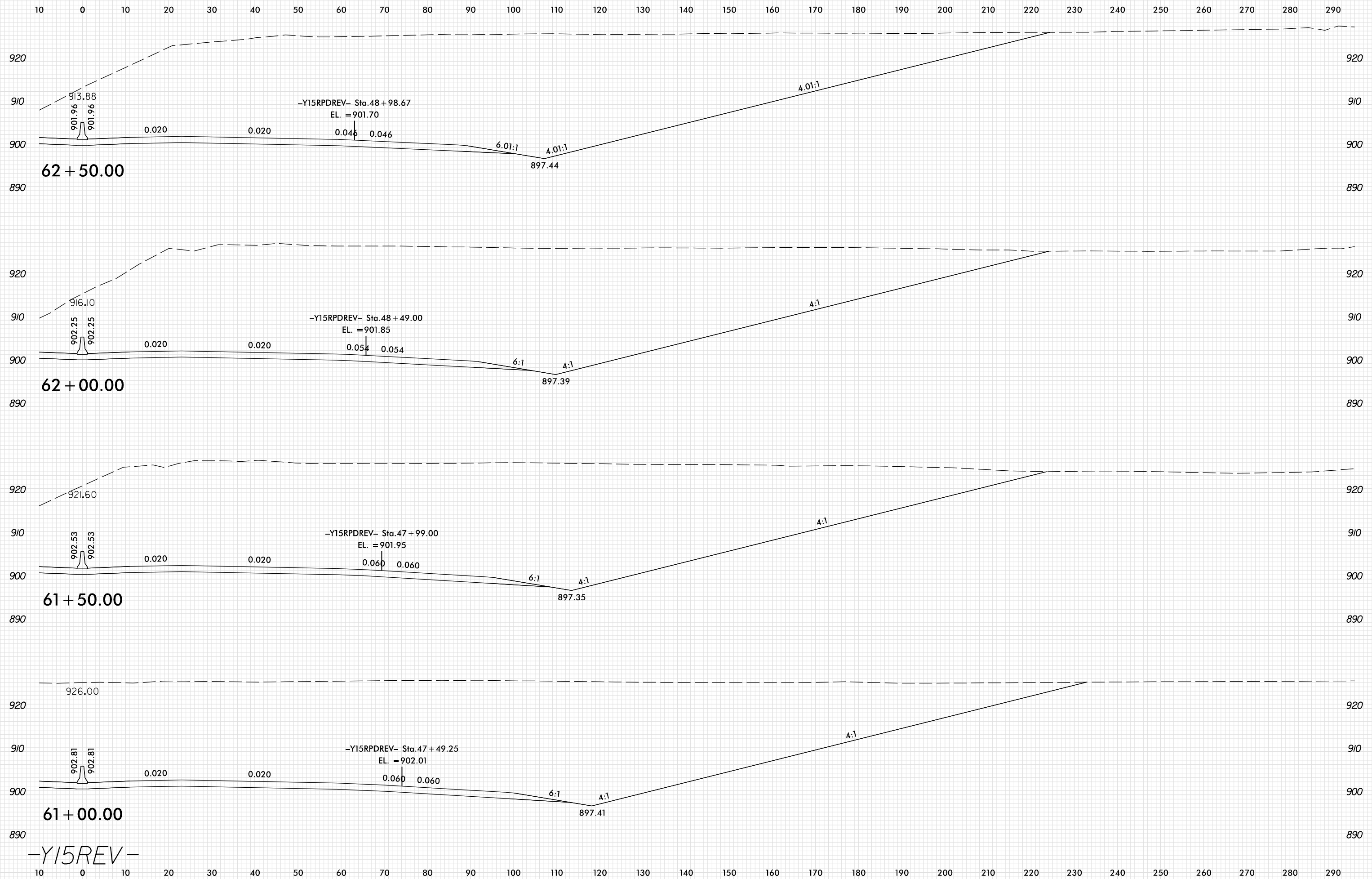

PLOT DRIVER: NCD01_pdf_color_eng_100.plt
 USER: SPEREIRA
 DATE: 6/10/2021
 TIME: 2:24:10 PM
 FILE: \

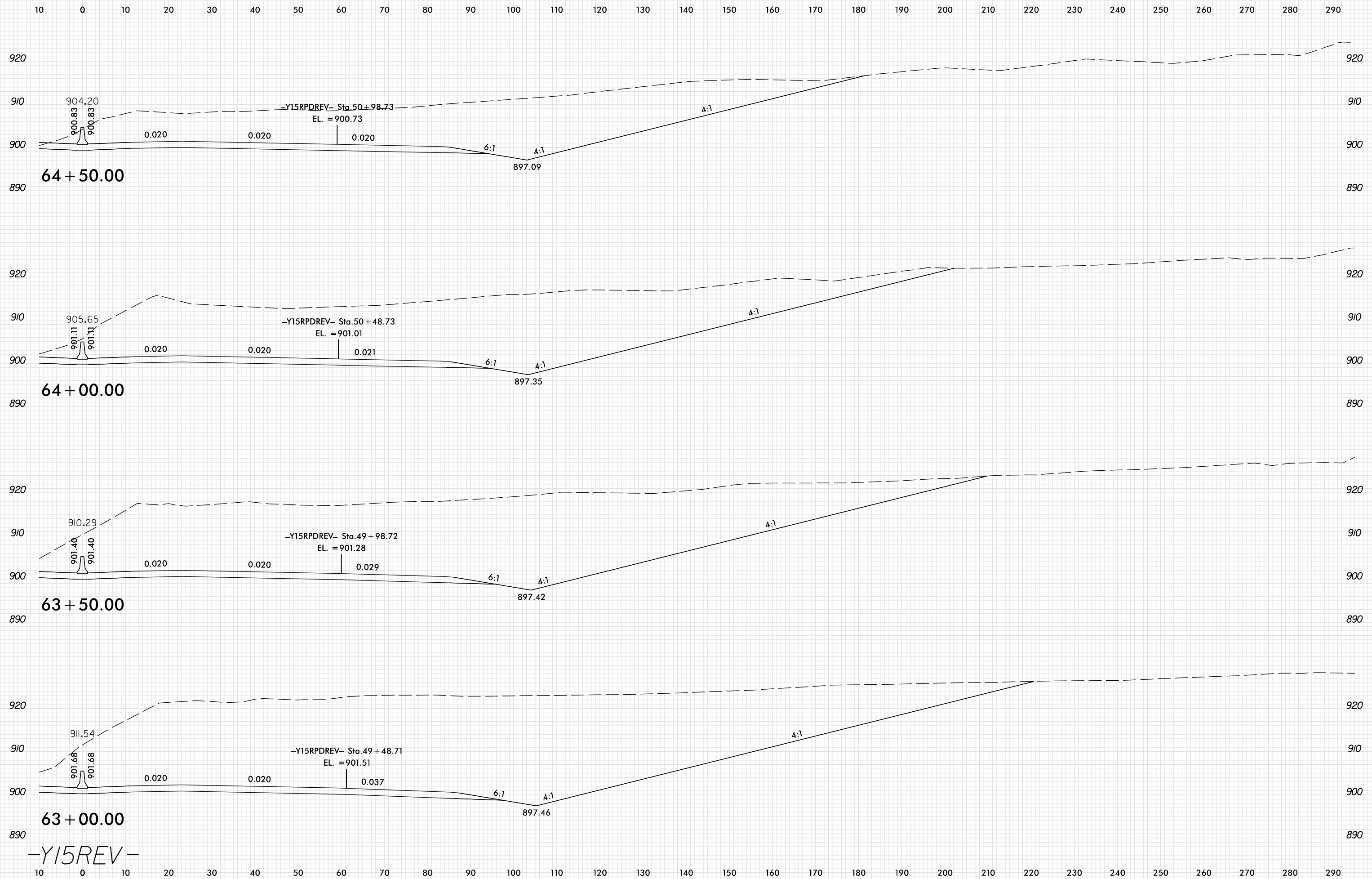

8/23/99

10 0 10 20 30 40 50 60 70 80 90 100 110 120 130 140 150 160 170 180 190 200 210 220 230 240 250 260 270 280 290

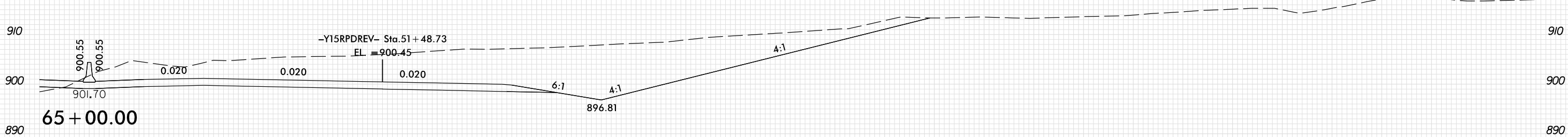
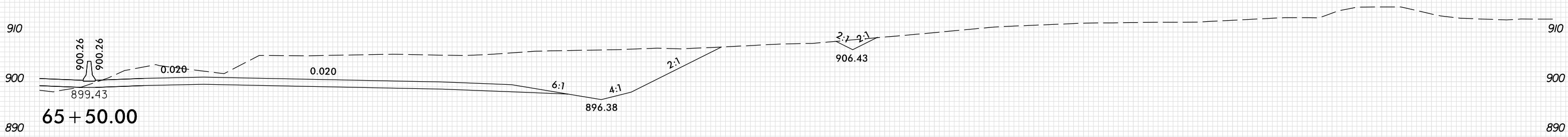
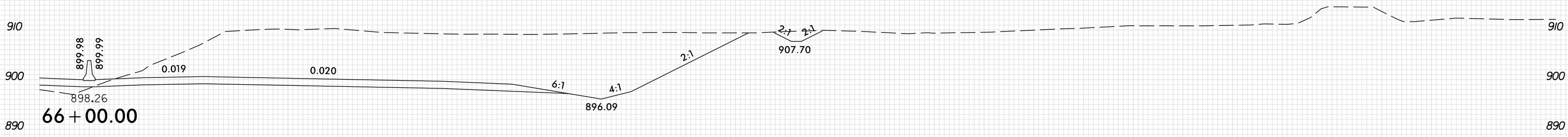
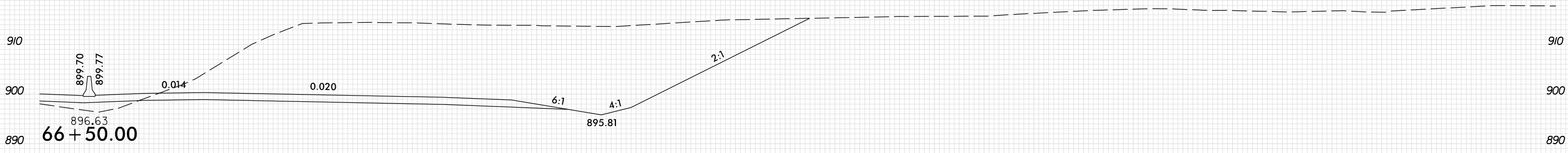

-Y15REV-

10 0 10 20 30 40 50 60 70 80 90 100 110 120 130 140 150 160 170 180 190 200 210 220 230 240 250 260 270 280 290

PLOT DRIVER: NCD01_pdf_color_eng_100.plt
USER: SPEREIRA
DATE: 6/10/2021
TIME: 2:24:11 PM
FILE: \

8/23/99



PROJ. REFERENCE NO.	SHEET NO.
U-2579AB	X-356

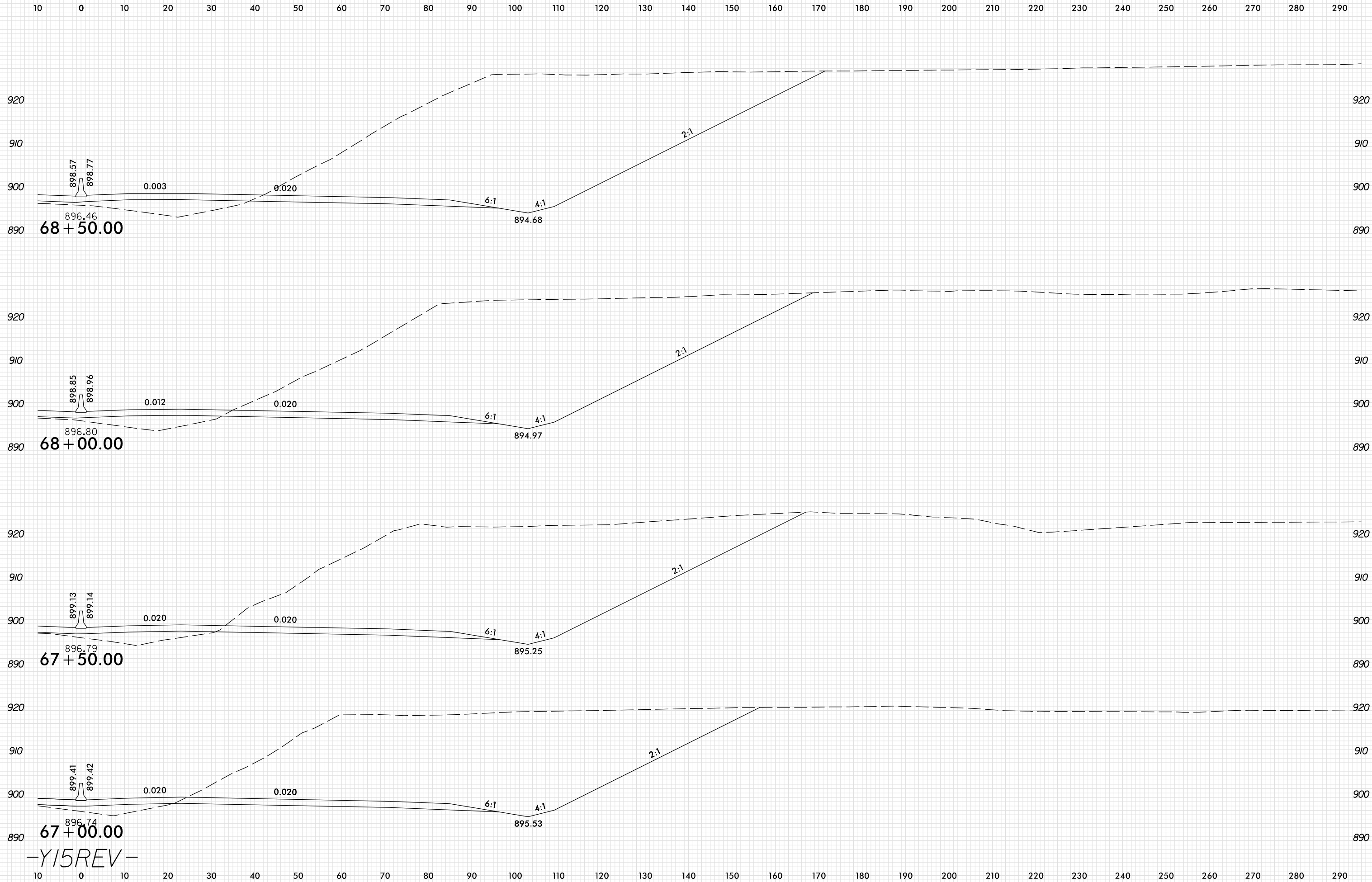

PLOT DRIVER: NCD01_pdf_color_eng_100.plt
 USER: SPEREIRA DATE: 6/10/2021 TIME: 2:24:12 PM
 FILE: \

890 **67+00.00**
 -Y15REV-

8/23/99

10 0 10 20 30 40 50 60 70 80 90 100 110 120 130 140 150 160 170 180 190 200 210 220 230 240 250 260 270 280 290

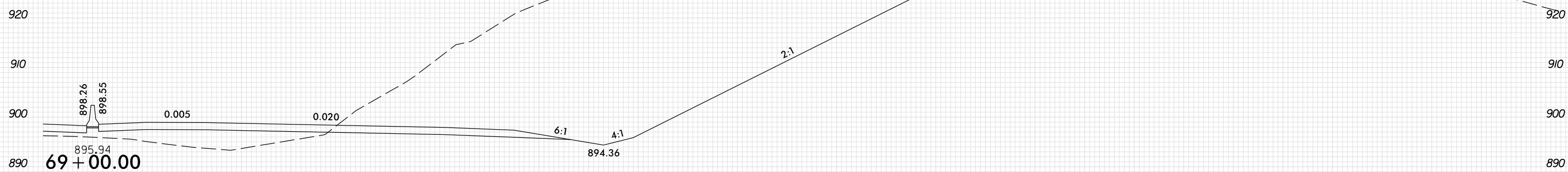
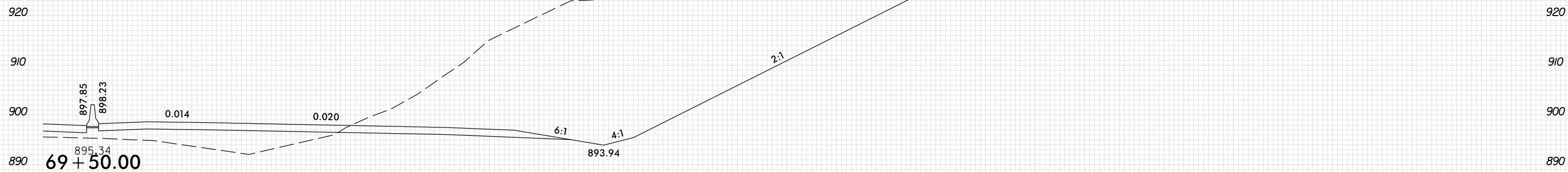
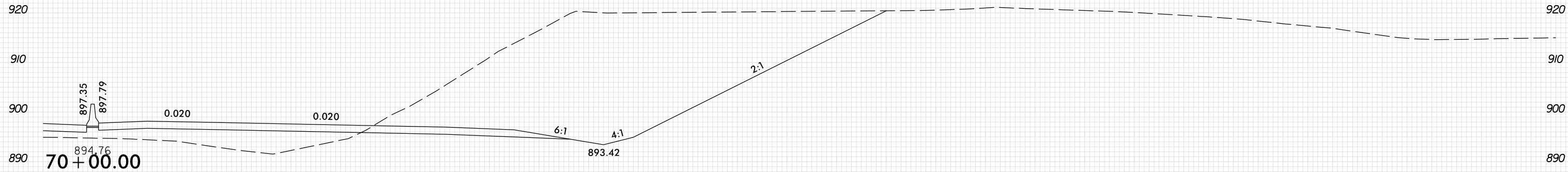

-Y15REV-

10 0 10 20 30 40 50 60 70 80 90 100 110 120 130 140 150 160 170 180 190 200 210 220 230 240 250 260 270 280 290

PLOT DRIVER: NCDOT_pdf_color_eng_100.plt
USER: SPEREIRA
DATE: 6/10/2021
TIME: 2:24:12 PM
FILE: \

8/23/99

10 0 10 20 30 40 50 60 70 80 90 100 110 120 130 140 150 160 170 180 190 200 210 220 230 240 250 260 270 280 290

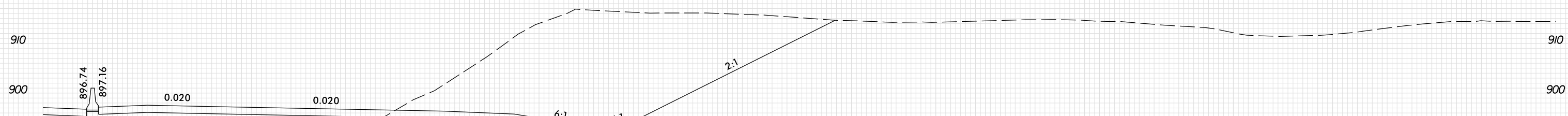
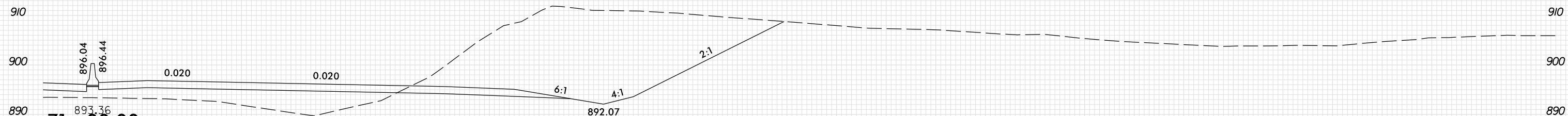
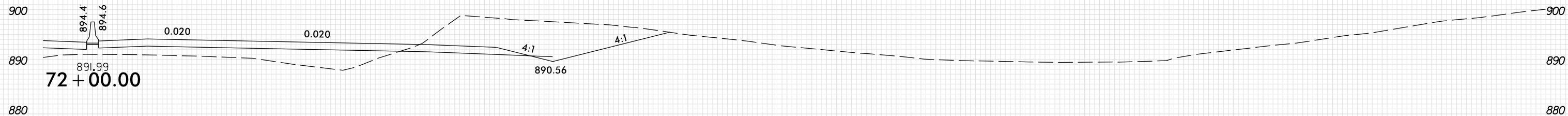

-Y15REV-

10 0 10 20 30 40 50 60 70 80 90 100 110 120 130 140 150 160 170 180 190 200 210 220 230 240 250 260 270 280 290

PLOT DRIVER: NCD01_pdf_color_eng_100.plt
USER: SPEREIRA
DATE: 6/10/2021
TIME: 2:24:13 PM
FILE: \

8/23/99

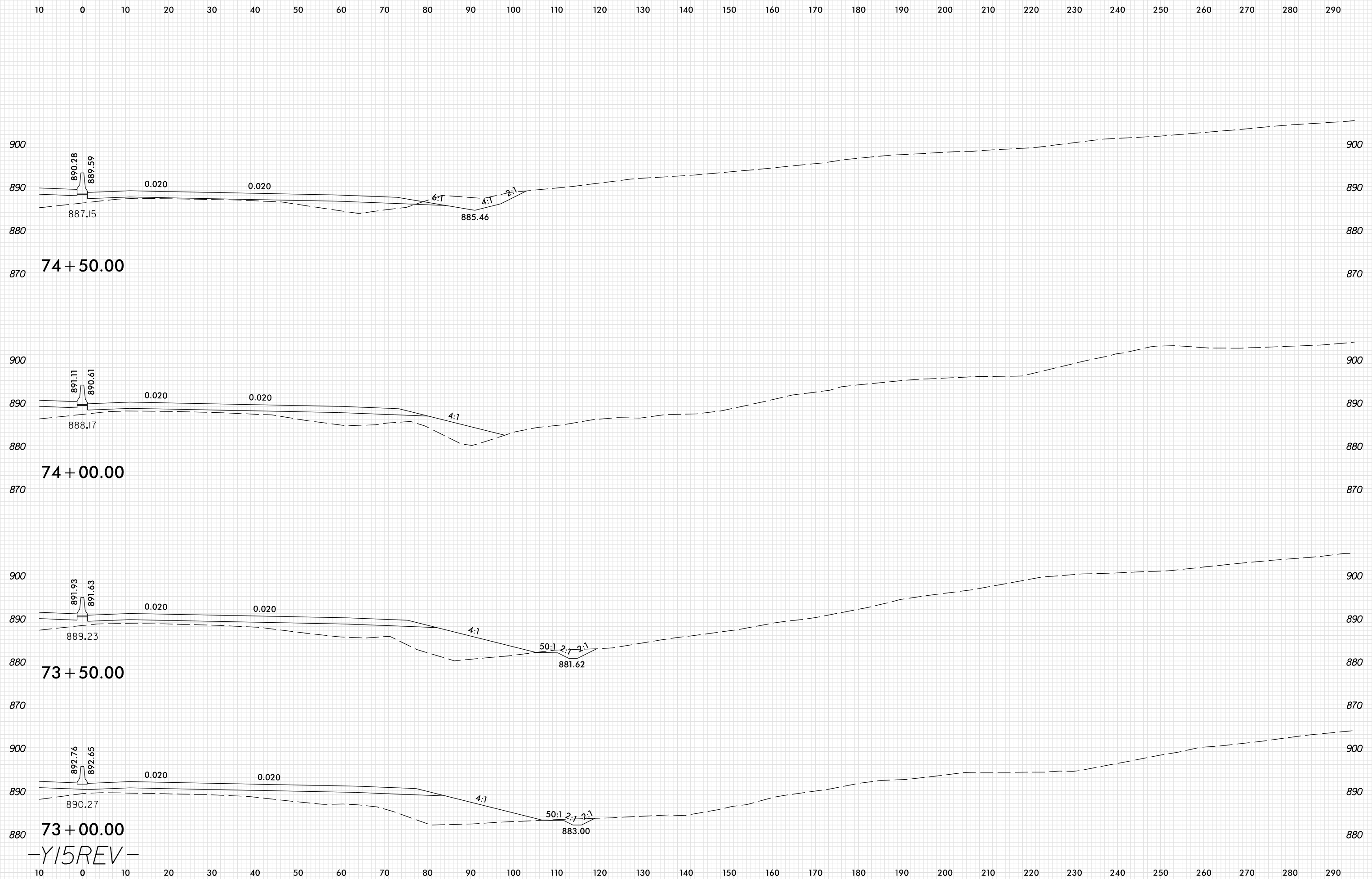

PLOT DRIVER: NCD01_.pdf_color_eng_100.plt
 USER: SPEREIRA
 DATE: 6/10/2021
 TIME: 2:24:14 PM
 FILE: \

-Y15REV-

8/23/99

0 5 10	PROJ. REFERENCE NO.	SHEET NO.
	U-2579AB	X-360

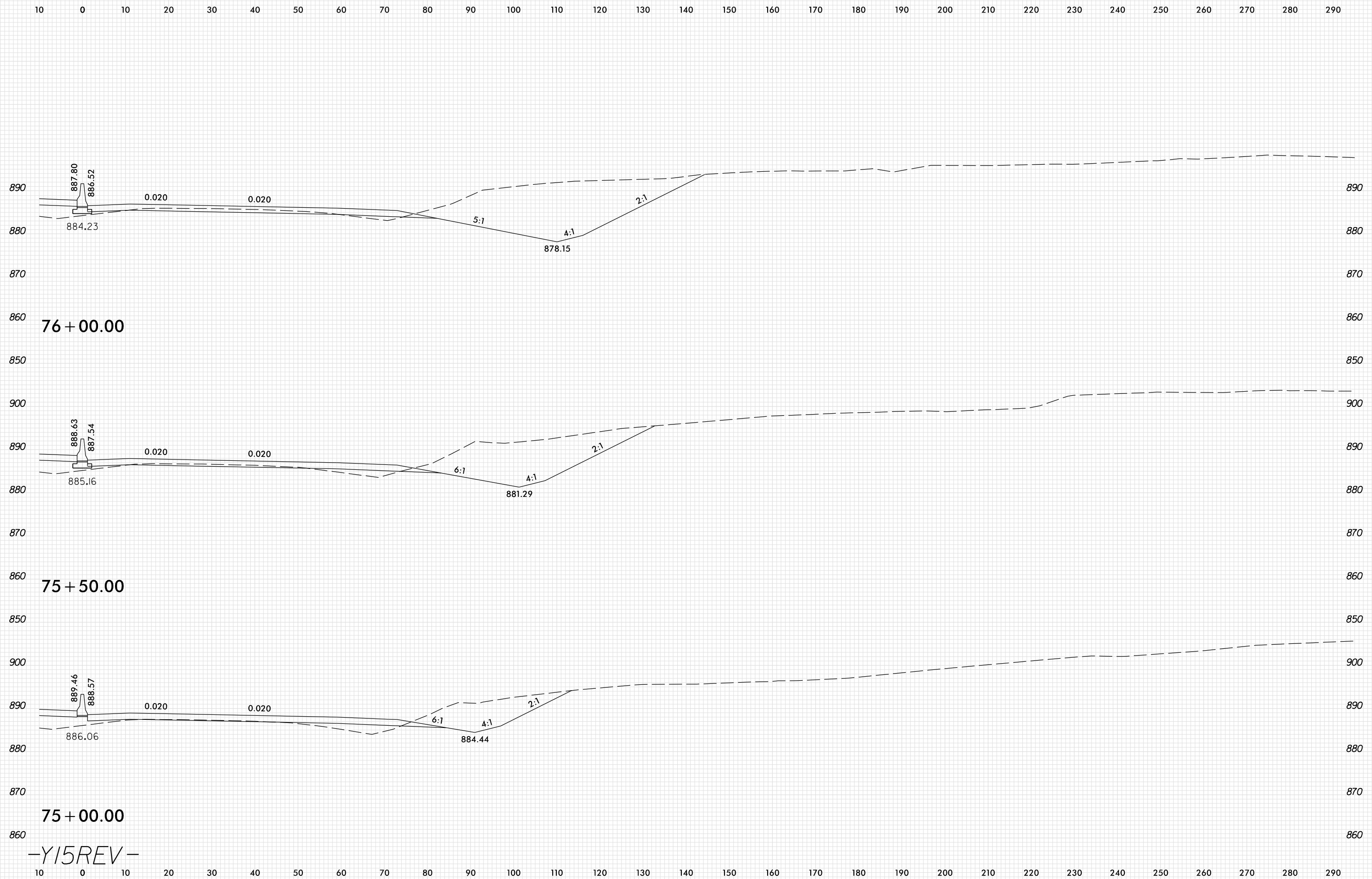

PLOT DRIVER: NCD01_pdf_color_eng_100.plt
 USER: SPEREIRA
 DATE: 6/10/2021
 TIME: 2:24:15 PM
 FILE: \

75+00.00
 -Y15REV-

8/23/99

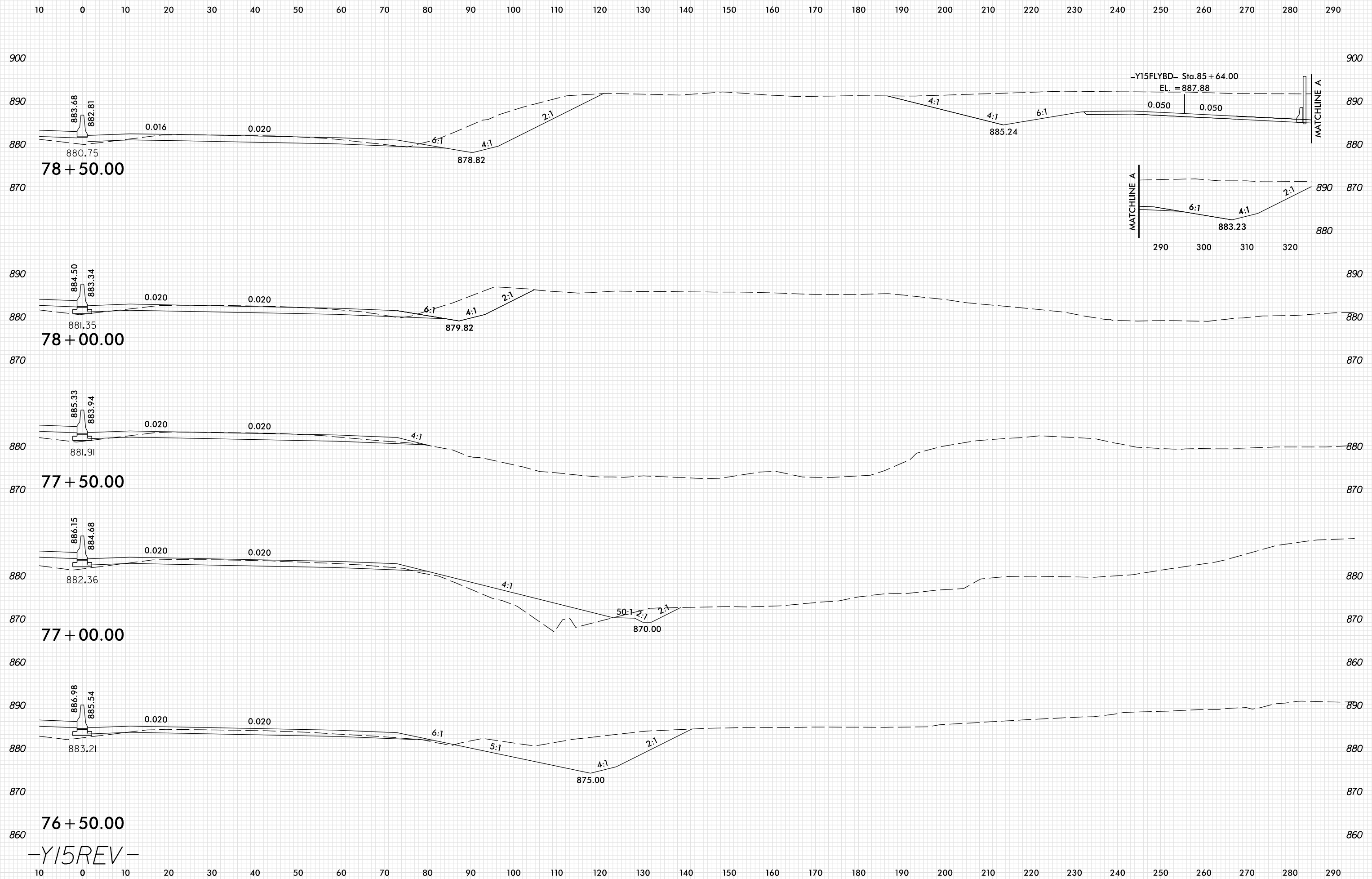

PLOT DRIVER: NCDOT_pdf_color_eng_100.plt
 USER: SPEREIRA
 DATE: 6/10/2021
 TIME: 2:24:15 PM
 FILE: \

8/23/99

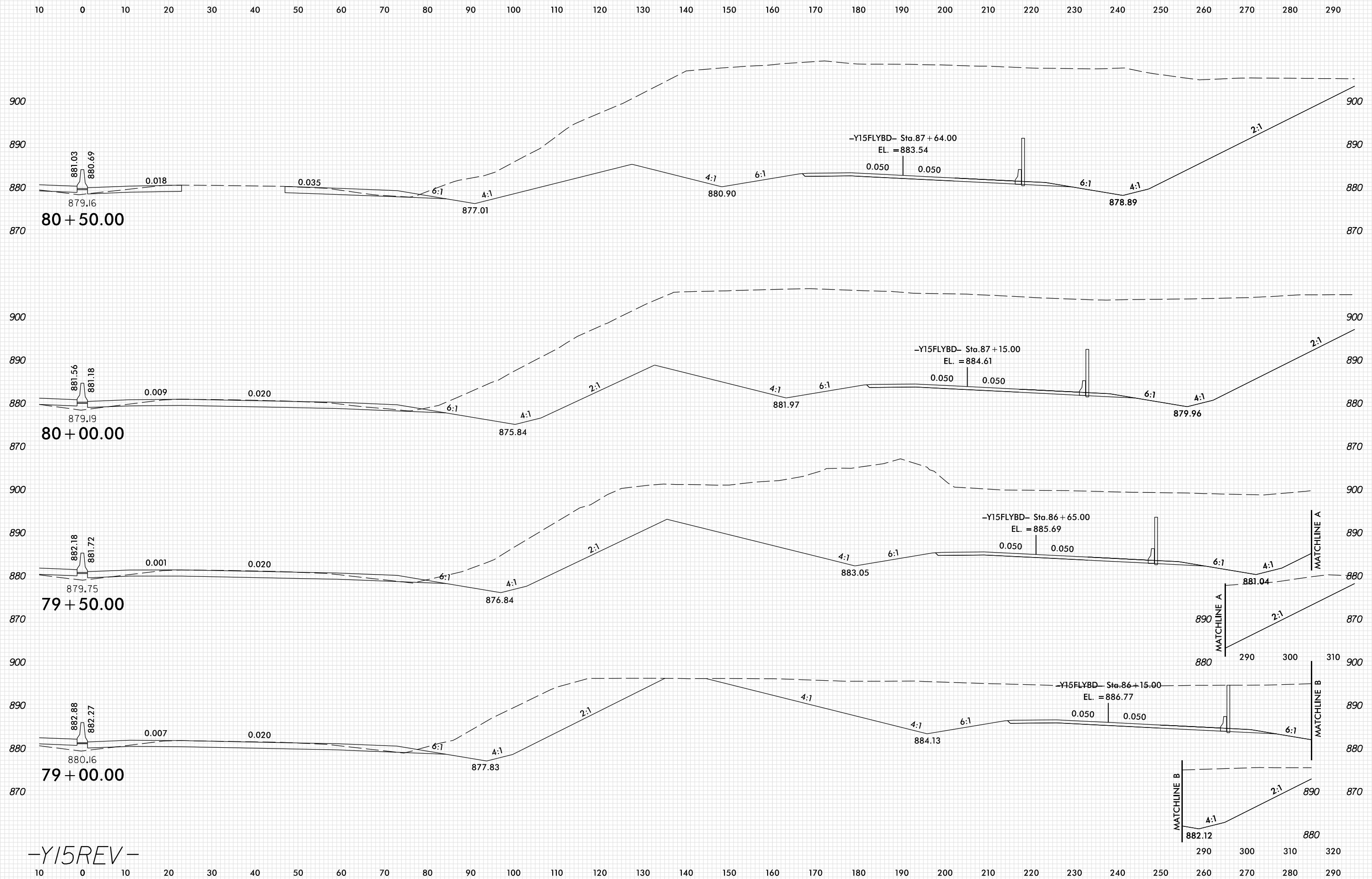

-Y15REV-

PLOT DRIVER: NCD01_pdf_color_eng_100.plt
 USER: SPEREIRA
 DATE: 6/10/2021
 TIME: 2:24:16 PM
 FILE: \

8/23/99

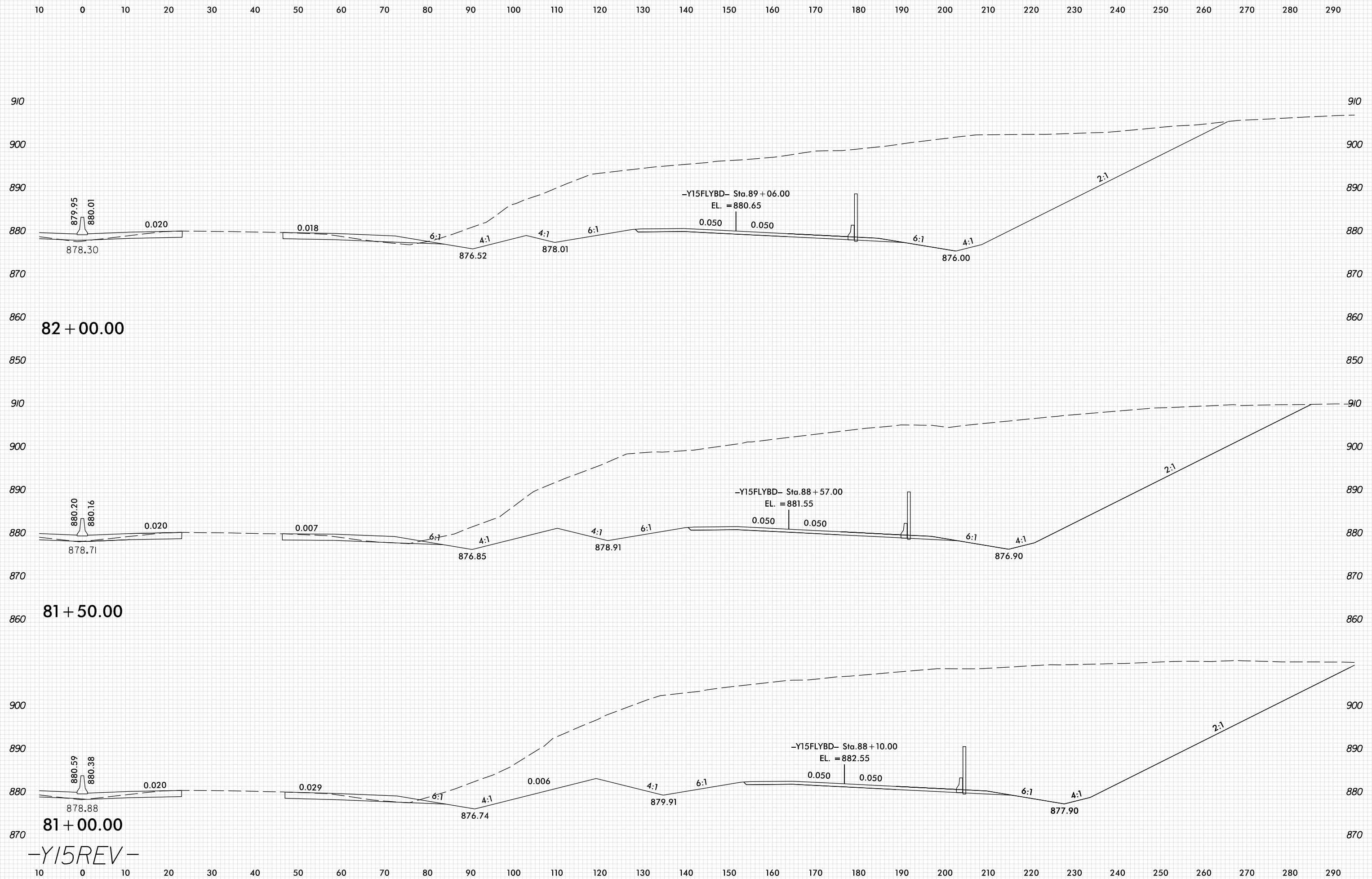

PLOT DRIVER: NCDOT_pdf_color_eng_100.plt
 USER: SPEREIRA
 DATE: 6/10/2021
 TIME: 2:24:17 PM
 FILE: \

82 + 00.00

81 + 50.00

81 + 00.00

-Y15REV-

8/23/99

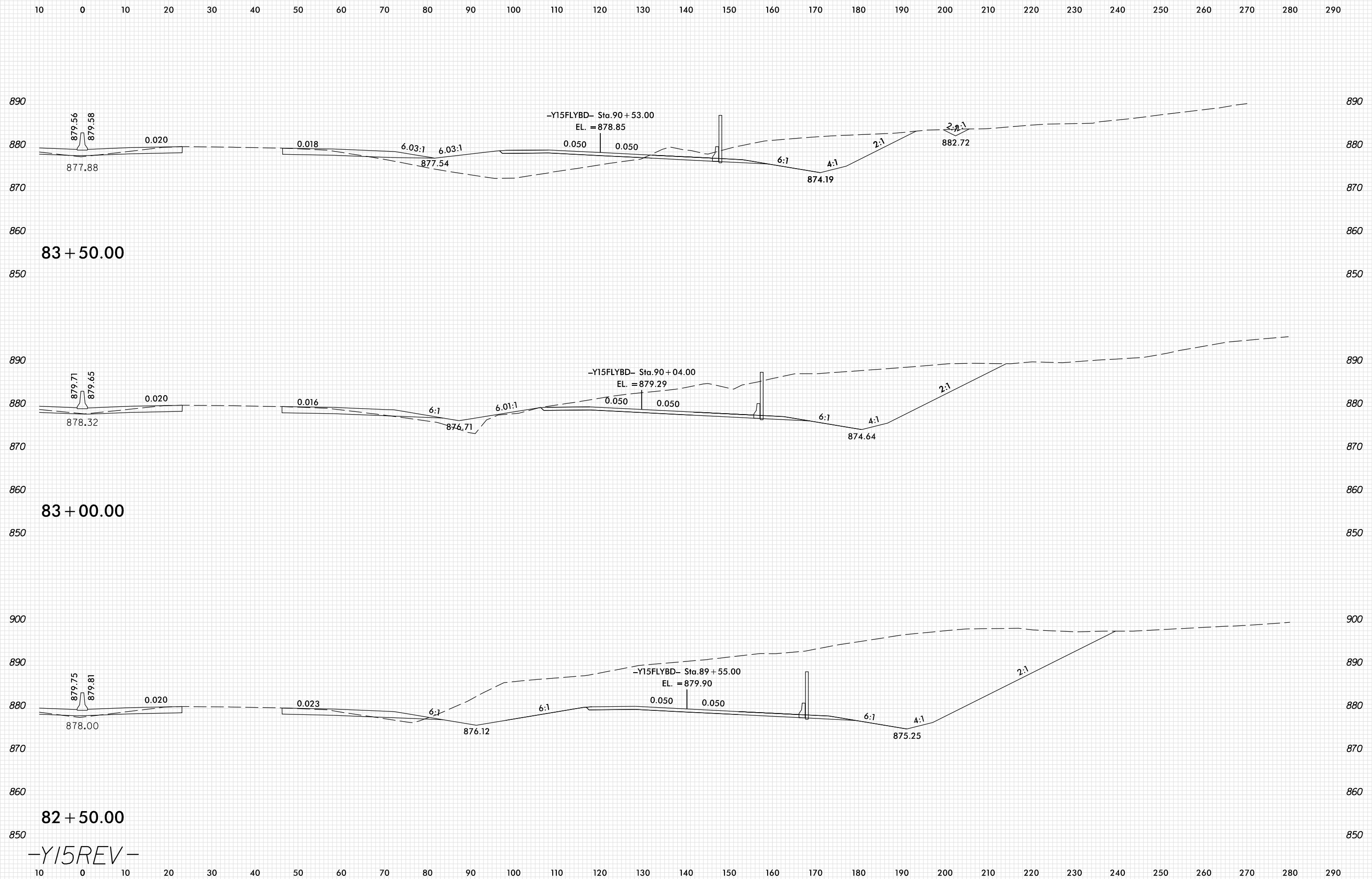

PLOT DRIVER: NCD01_.pdf_color_eng_100.plt
 USER: SPEREIRA
 DATE: 6/10/2021
 TIME: 2:24:17 PM
 FILE: \

82 + 50.00
 -Y15REV-

8/23/99

10 0 10 20 30 40 50 60 70 80 90 100 110 120 130 140 150 160 170 180 190 200 210 220 230 240 250 260 270 280 290

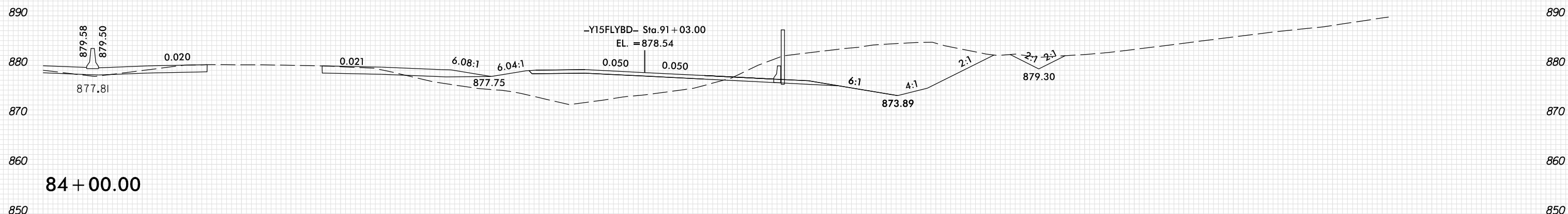
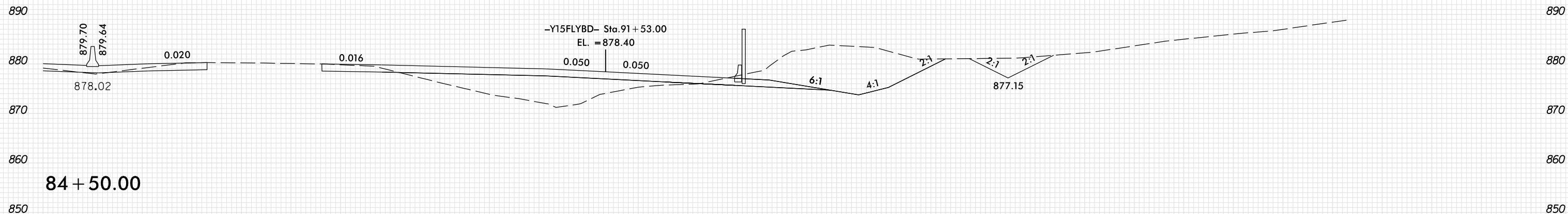
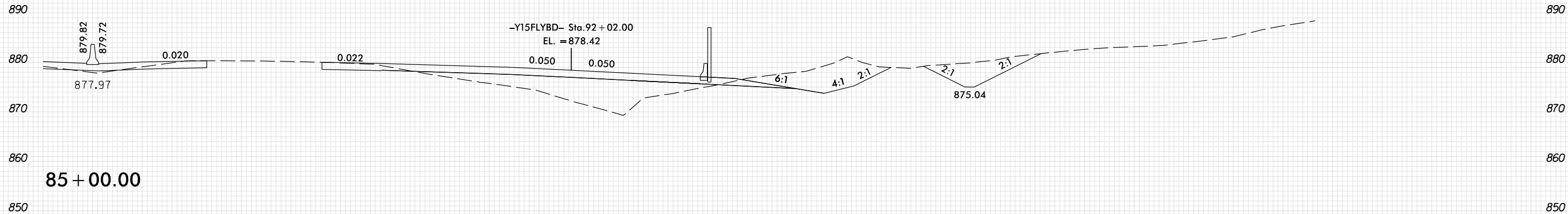

-Y15REV-

10 0 10 20 30 40 50 60 70 80 90 100 110 120 130 140 150 160 170 180 190 200 210 220 230 240 250 260 270 280 290

PLOT DRIVER: NCD01_.pdf_color_eng_100.plt
USER: SPEREIRA
DATE: 6/10/2021
TIME: 2:24:18 PM
FILE: \

8/23/99

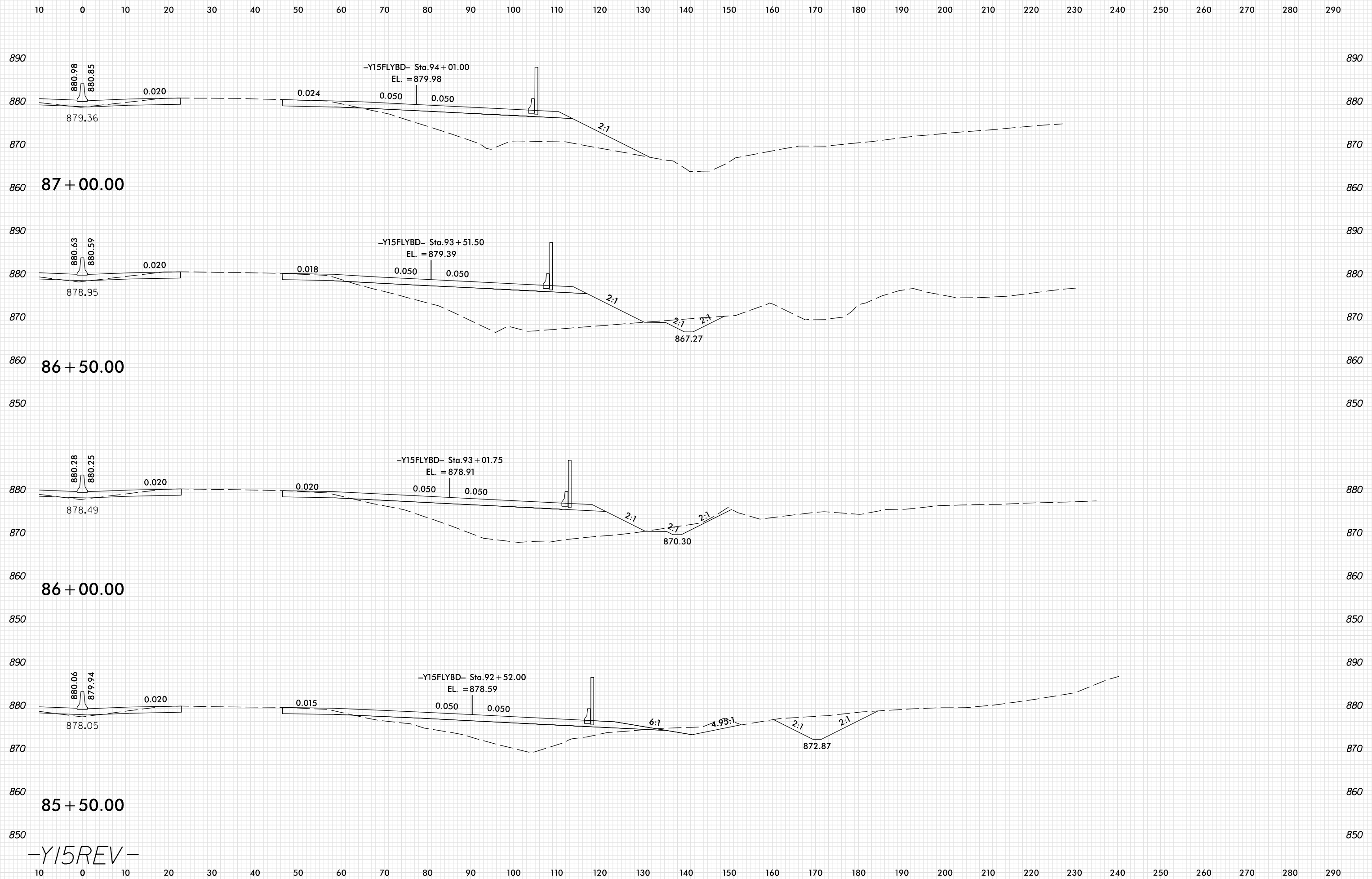

PLOT DRIVER: NCD01...pdf_color_eng_100.plt
 USER: SPEREIRA
 DATE: 6/10/2021
 TIME: 2:24:19 PM
 FILE: \

-Y15REV-

8/23/99

10 0 10 20 30 40 50 60 70 80 90 100 110 120 130 140 150 160 170 180 190 200 210 220 230 240 250 260 270 280 290

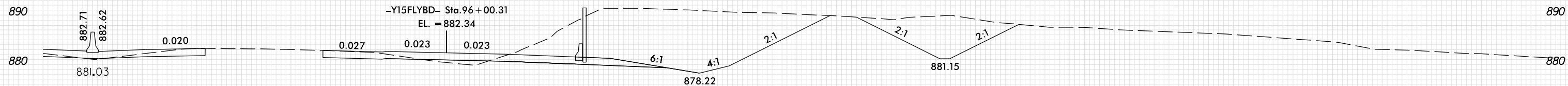

89 + 00.00

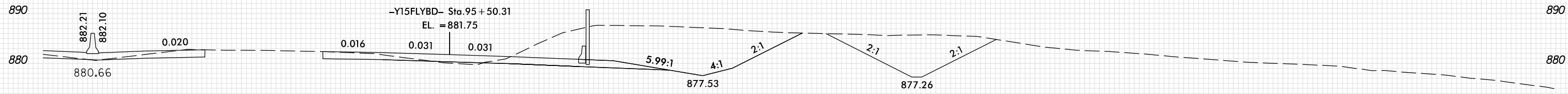

88 + 50.00

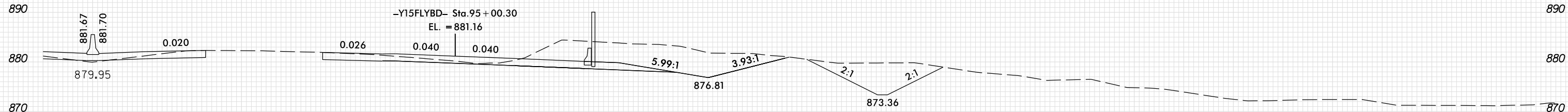

88 + 00.00

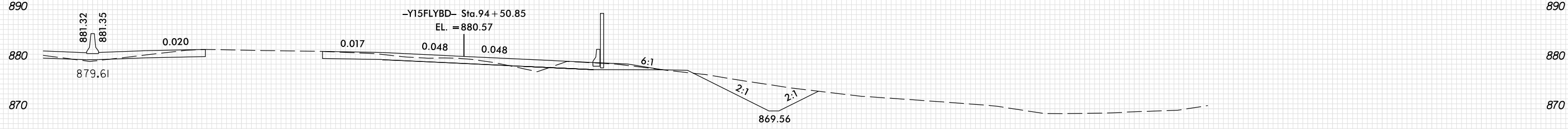

87 + 50.00

-Y15REV-

10 0 10 20 30 40 50 60 70 80 90 100 110 120 130 140 150 160 170 180 190 200 210 220 230 240 250 260 270 280 290

PLOT DRIVER: NCD01.pdf_color_eng_100.plt
USER: SPEREIRA
DATE: 6/10/2021
TIME: 2:24:19 PM
FILE: \

8/23/99

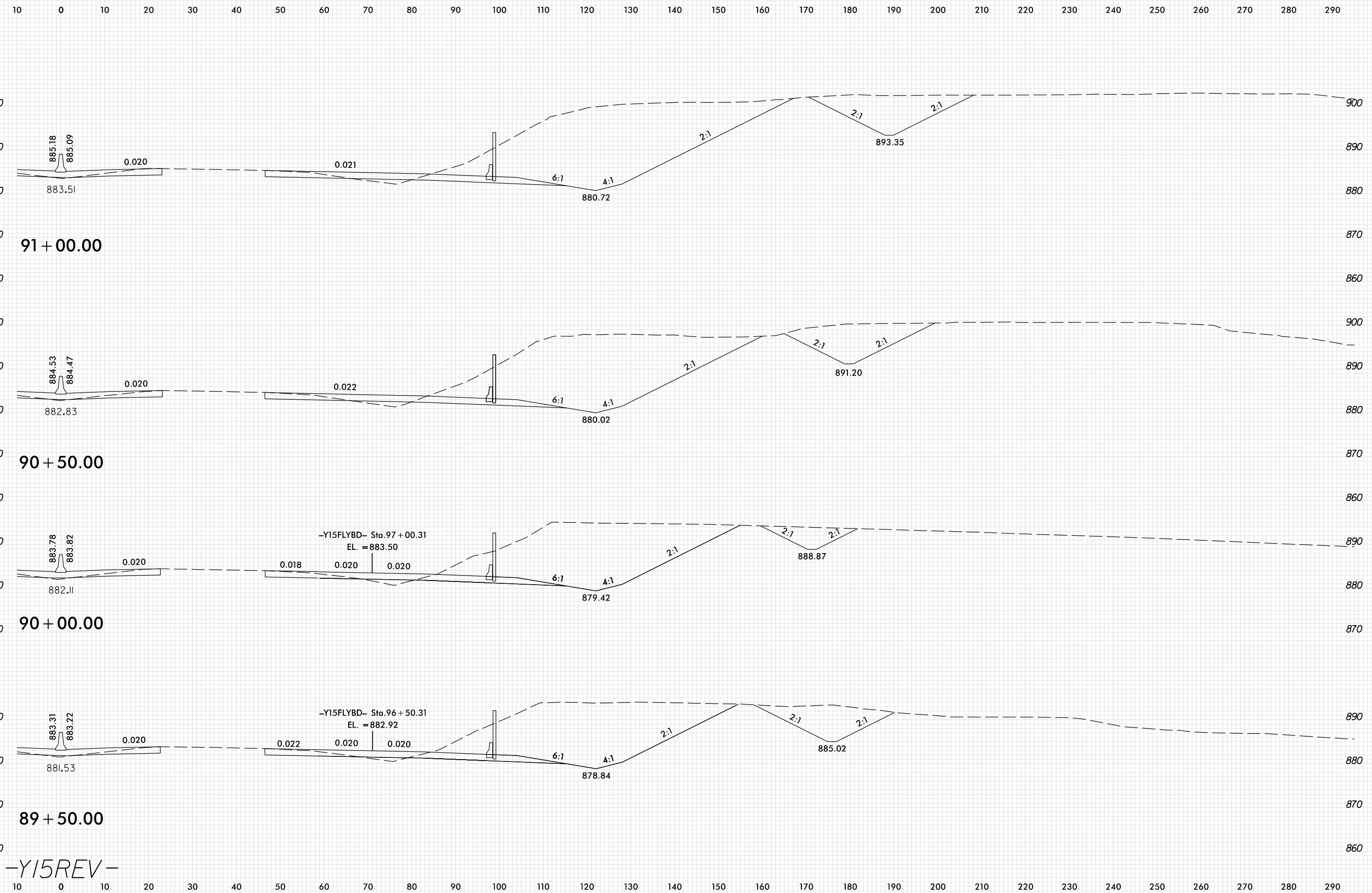

-Y15REV-

PLOT DRIVER: NCDOT_pdf_color_eng_100.plt
 USER: SPEREIRA
 DATE: 6/10/2021
 TIME: 2:24:21 PM
 FILE: \

8/23/99

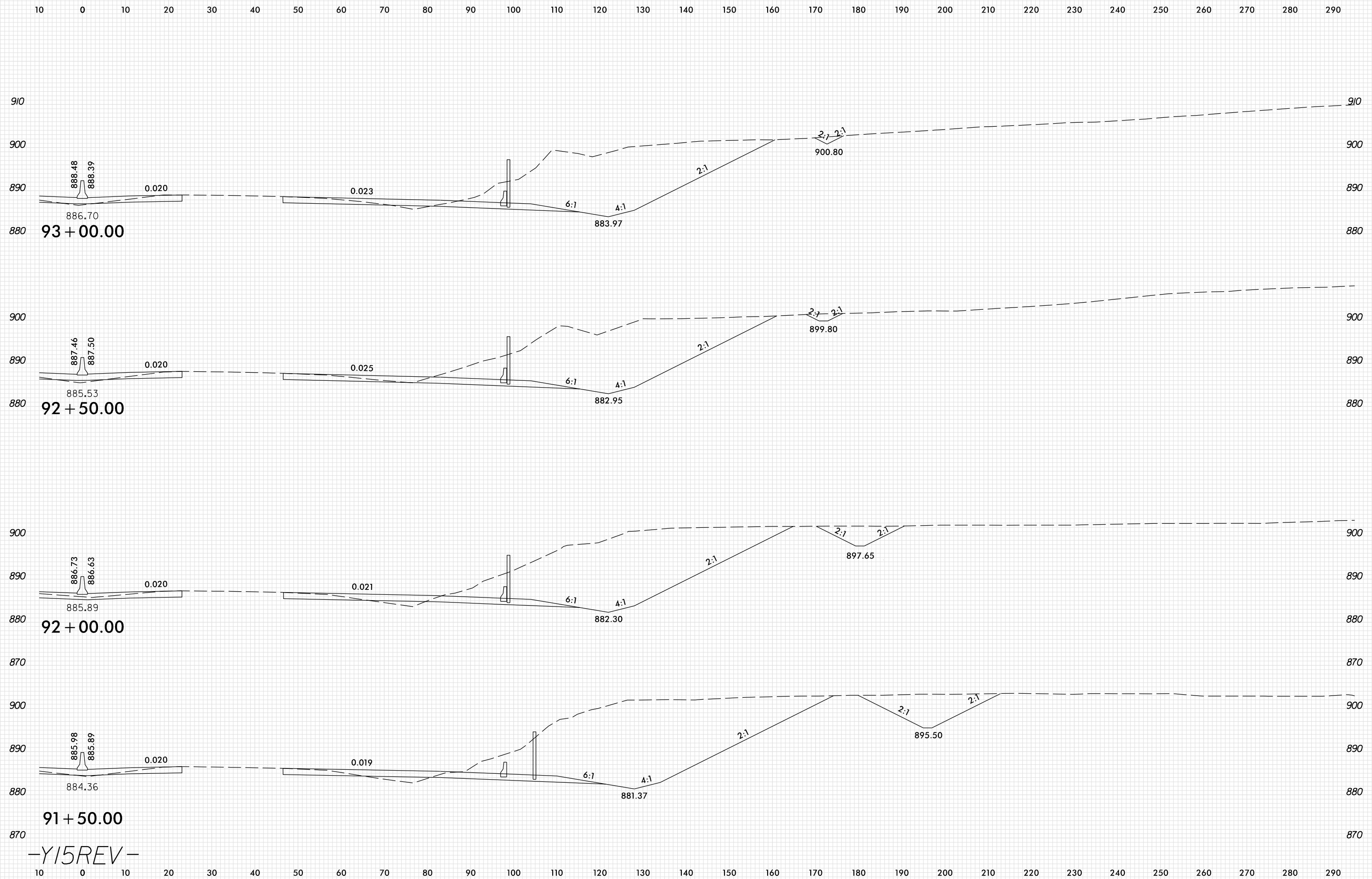

PLOT DRIVER: NCD01_pdr_color_eng_100.plt
 USER: SPEREIRA
 DATE: 6/10/2021
 TIME: 2:24:21 PM
 FILE: \

-Y15REV-

8/23/99

0 5 10	PROJ. REFERENCE NO.	SHEET NO.
	U-2579AB	X-370

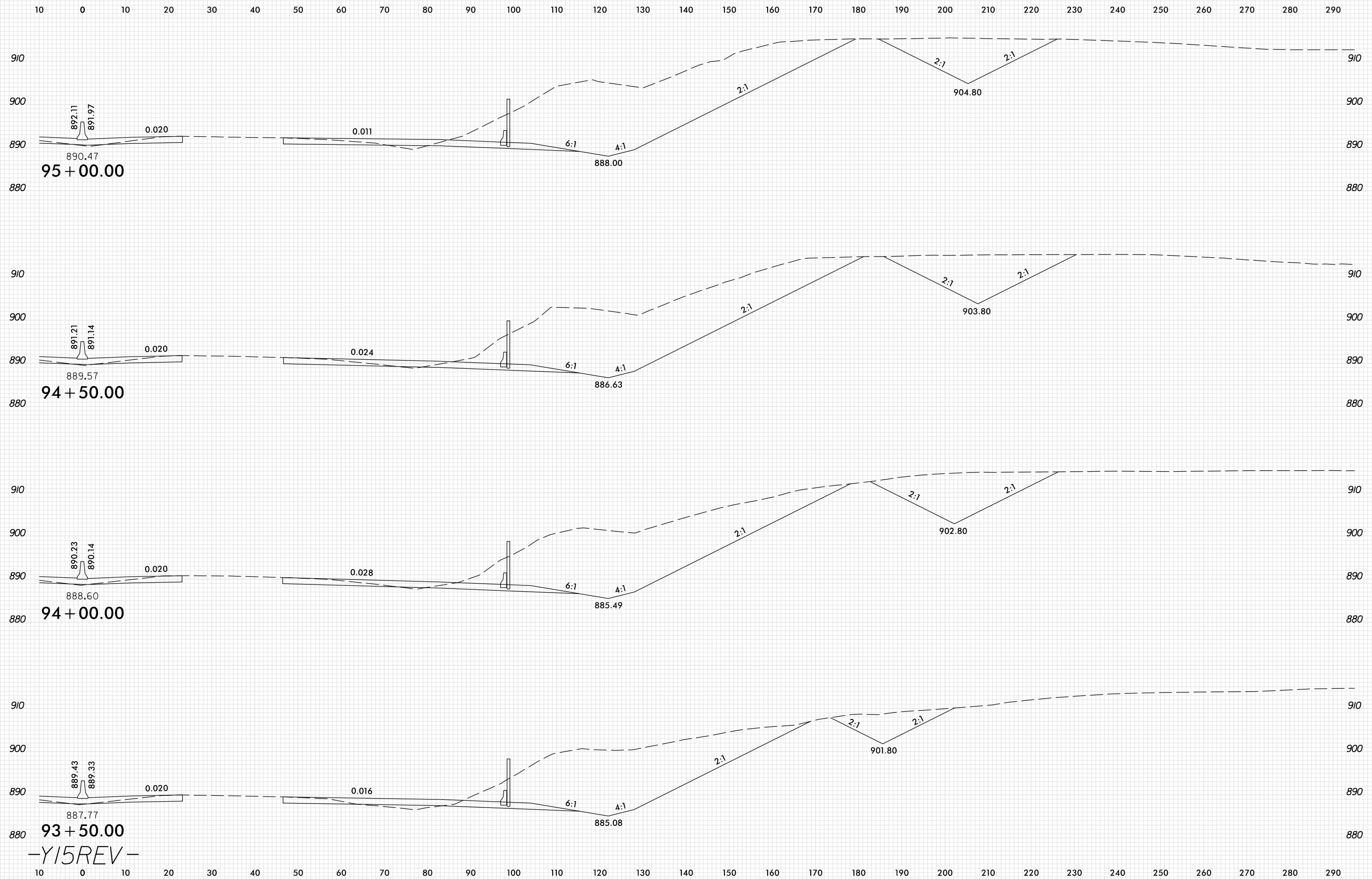

PLOT DRIVER: NCD01_pdf_color_eng_100.plt
 USER: SPEREIRA
 DATE: 6/10/2021
 TIME: 2:24:22 PM
 FILE: \

93+50.00
 -Y15REV-

8/23/99

10 0 10 20 30 40 50 60 70 80 90 100 110 120 130 140 150 160 170 180 190 200 210 220 230 240 250 260 270 280 290

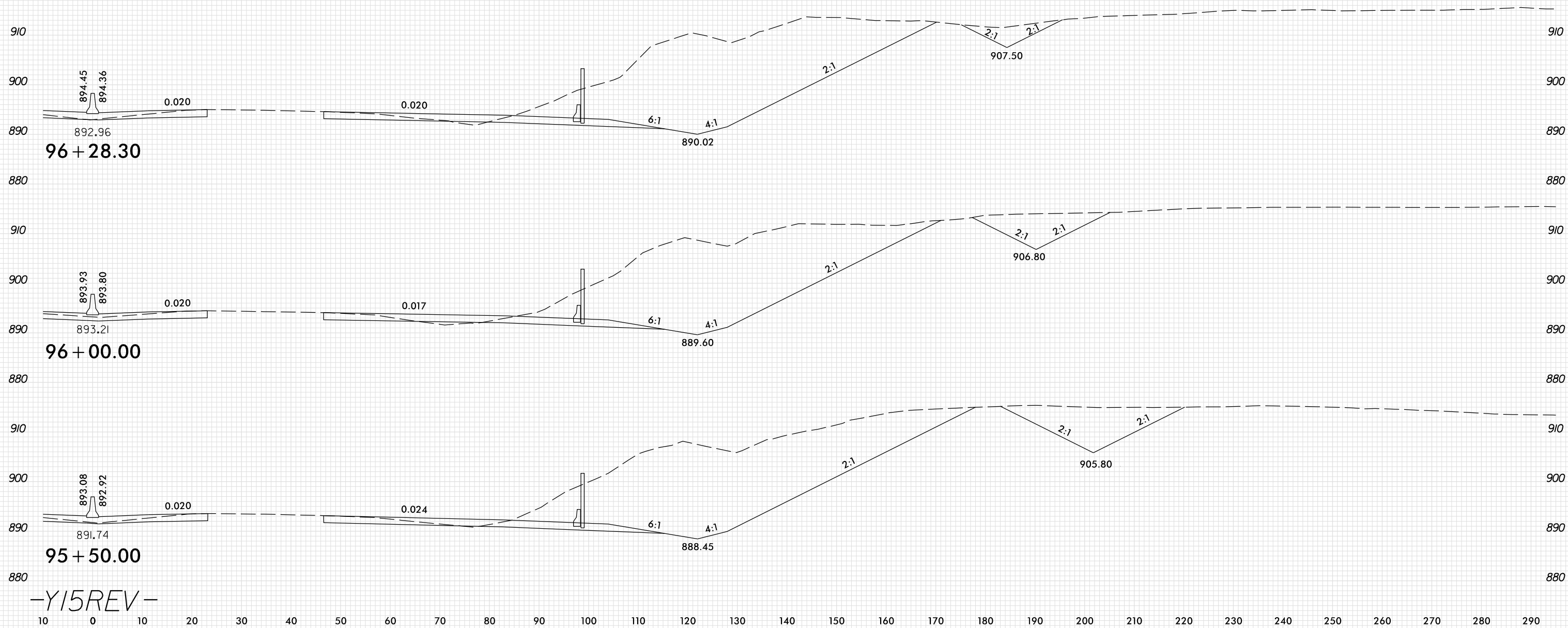

-Y15REV-

PLOT DRIVER: NCD01_pdf_color_eng_100.plt
 USER: SPEREIRA
 DATE: 6/10/2021
 TIME: 2:24:22 PM

8/23/99

0 5 10	PROJ. REFERENCE NO.	SHEET NO.
	U-2579AB	X-372

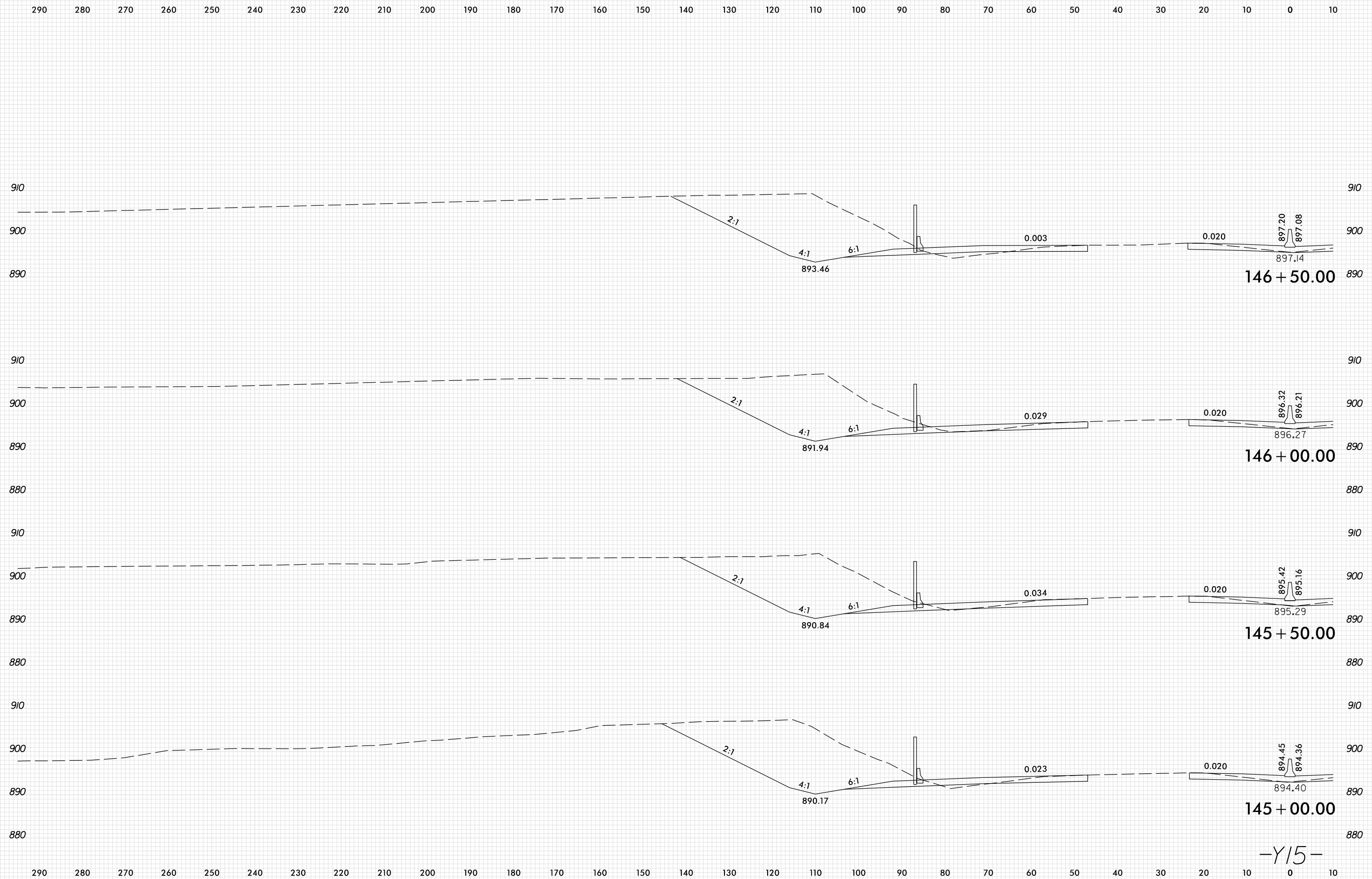

-Y15-

PLOT DRIVER: NCD01_pdf_color_eng_100.plt
 USER: SPEREIRA
 DATE: 6/10/2021
 TIME: 2:24:40 PM

8/23/99

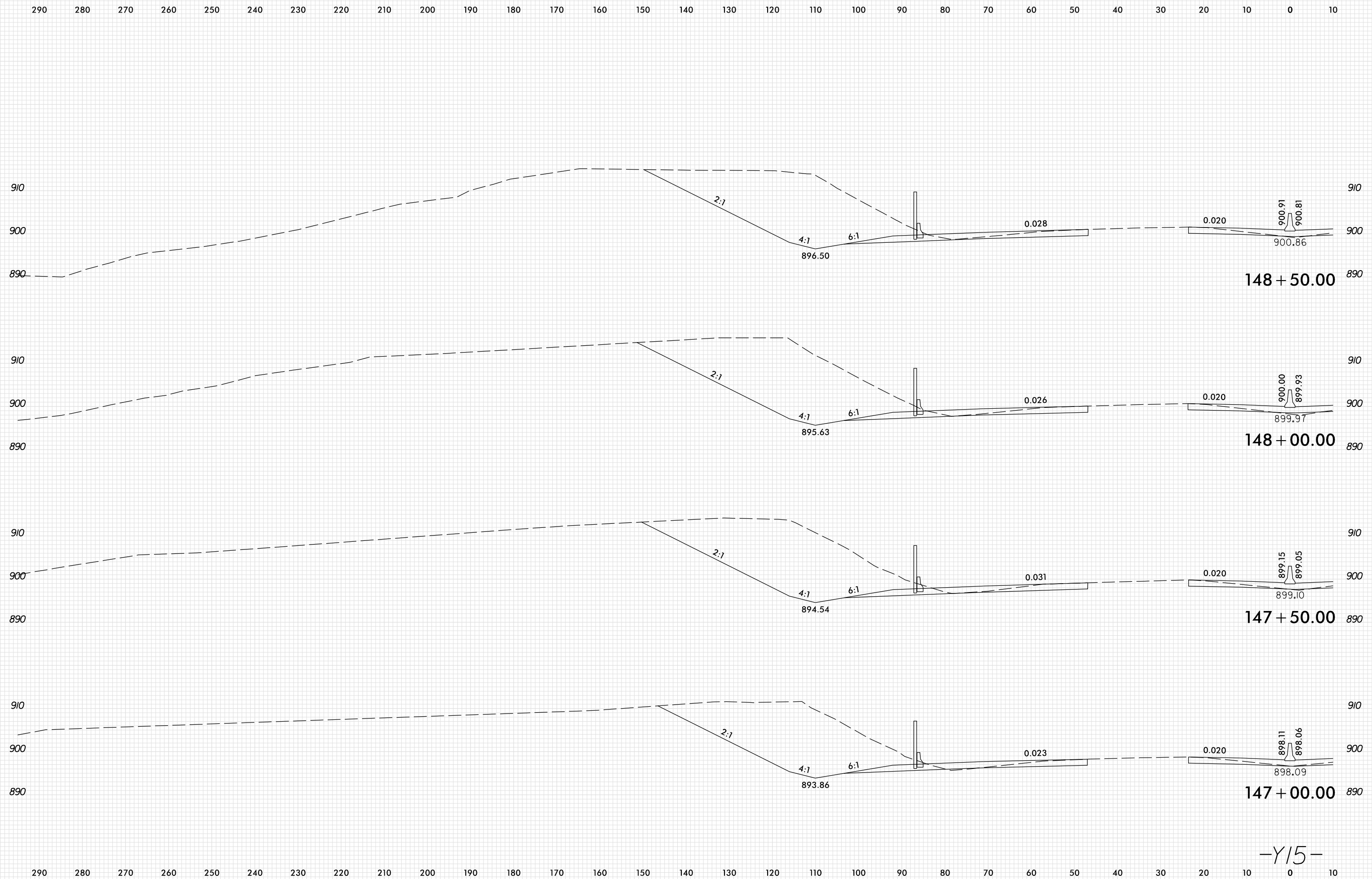

PLOT DRIVER: NCDOT_pdf_color_eng_100.plt
 USER: SPEREIRA
 DATE: 6/10/2021
 TIME: 2:24:41 PM
 FILE: \

8/23/99

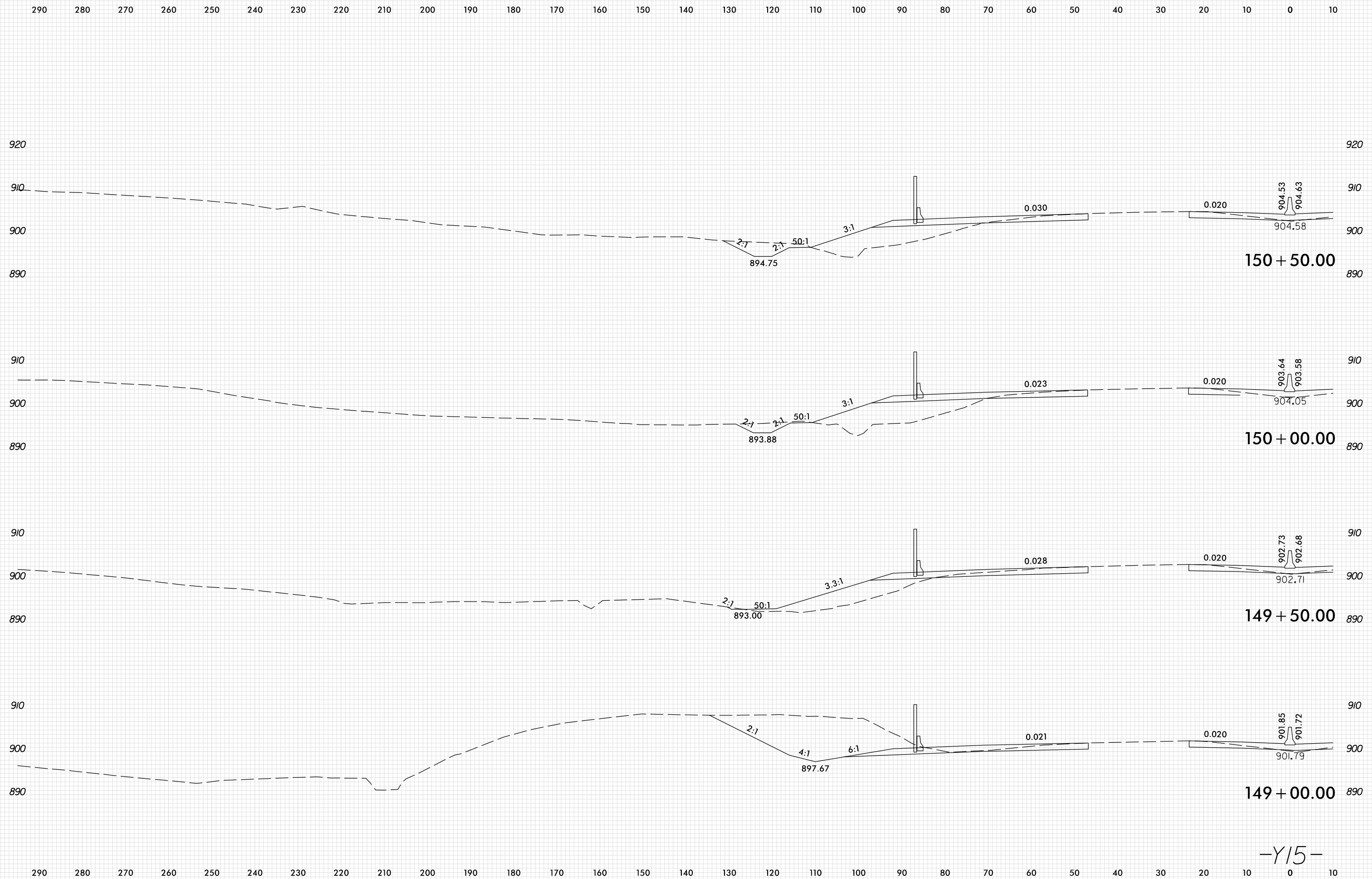

PLOT DRIVER: NCD01_pdf_color_eng_100.plt
 USER: SPEREIRA
 DATE: 6/10/2021
 TIME: 2:24:41 PM
 FILE: \

8/23/99

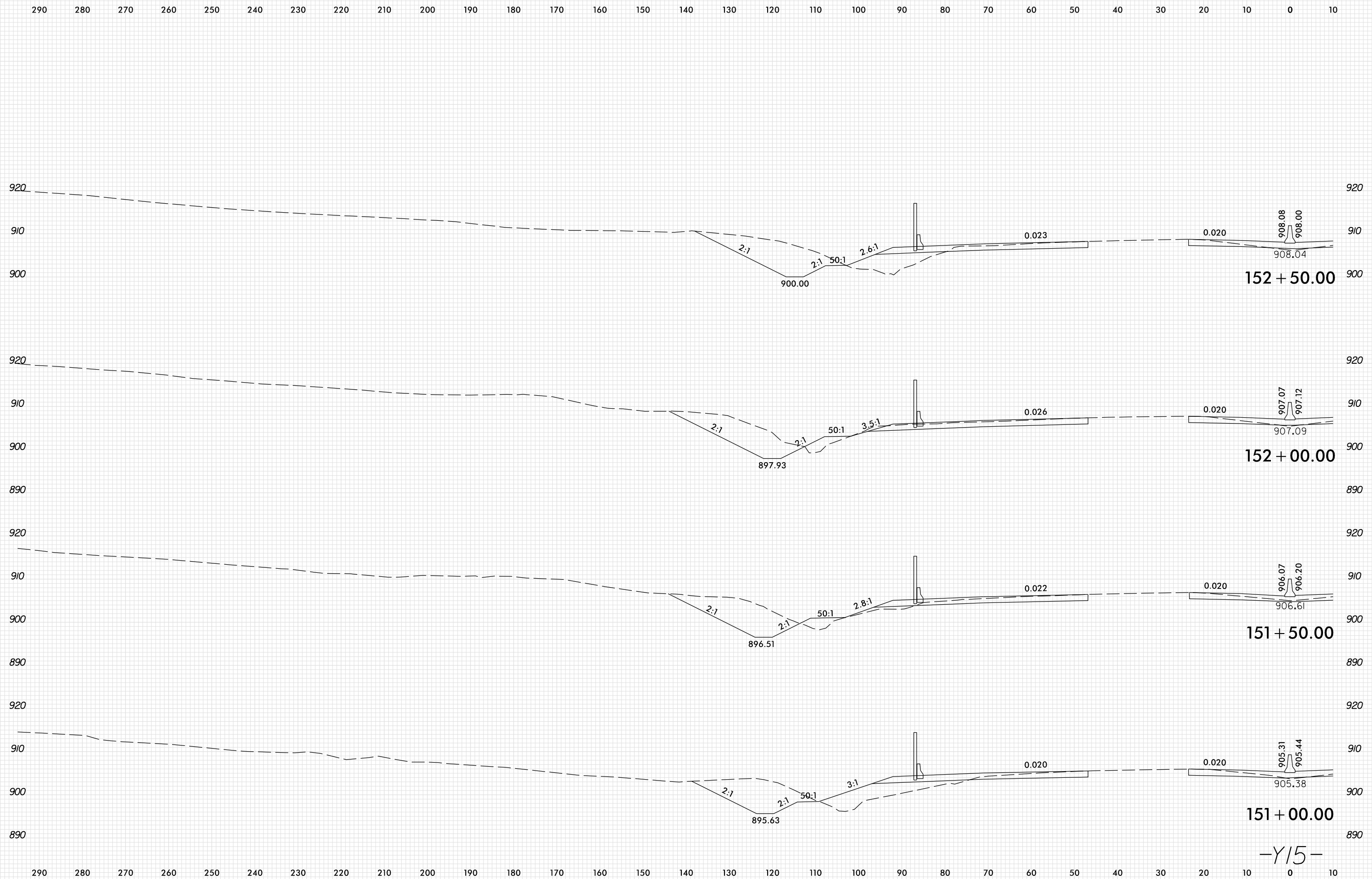

PLOT DRIVER: NCD01_pdf_color_eng_100.plt
 USER: SPEREIRA
 DATE: 6/10/2021
 TIME: 2:24:42 PM
 FILE: \

8/23/99

290 280 270 260 250 240 230 220 210 200 190 180 170 160 150 140 130 120 110 100 90 80 70 60 50 40 30 20 10 0 10

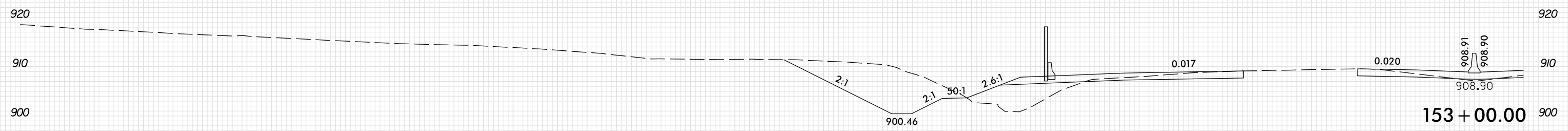
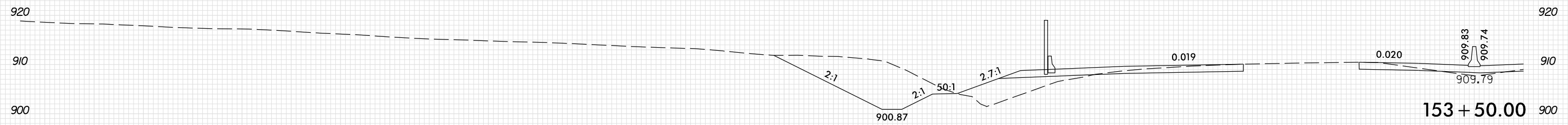
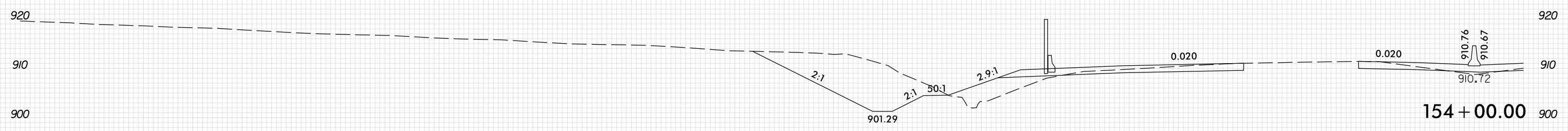
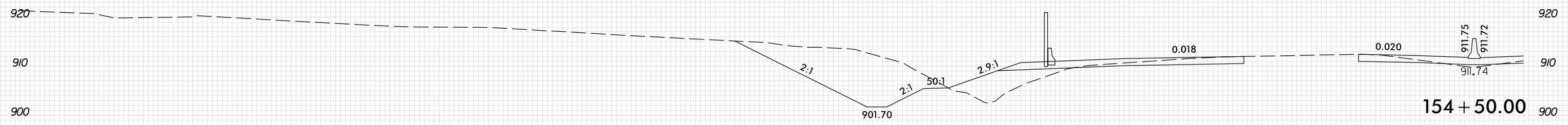

-Y15-

PLOT DRIVER: NCD01_pdf_color_eng_100.plt
 USER: SPEREIRA
 DATE: 6/10/2021
 TIME: 2:24:43 PM

8/23/99

0 5 10	PROJ. REFERENCE NO.	SHEET NO.
	U-2579AB	X-377

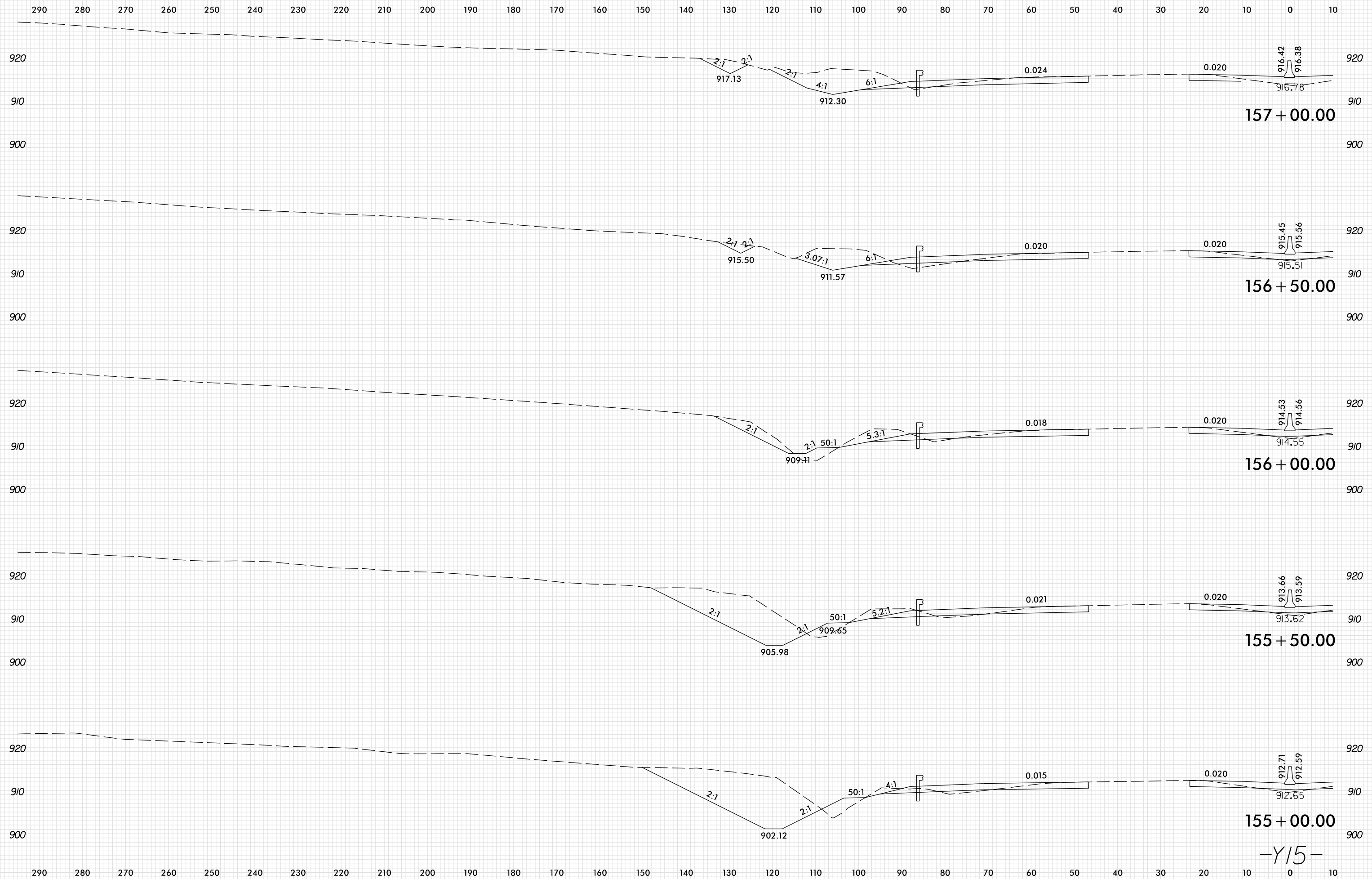

PLOT DRIVER: NCD01_pdf_color_eng_100.plt
 USER: SPEREIRA
 DATE: 6/10/2021
 TIME: 2:24:44 PM
 FILE: \

-Y15-

8/23/99

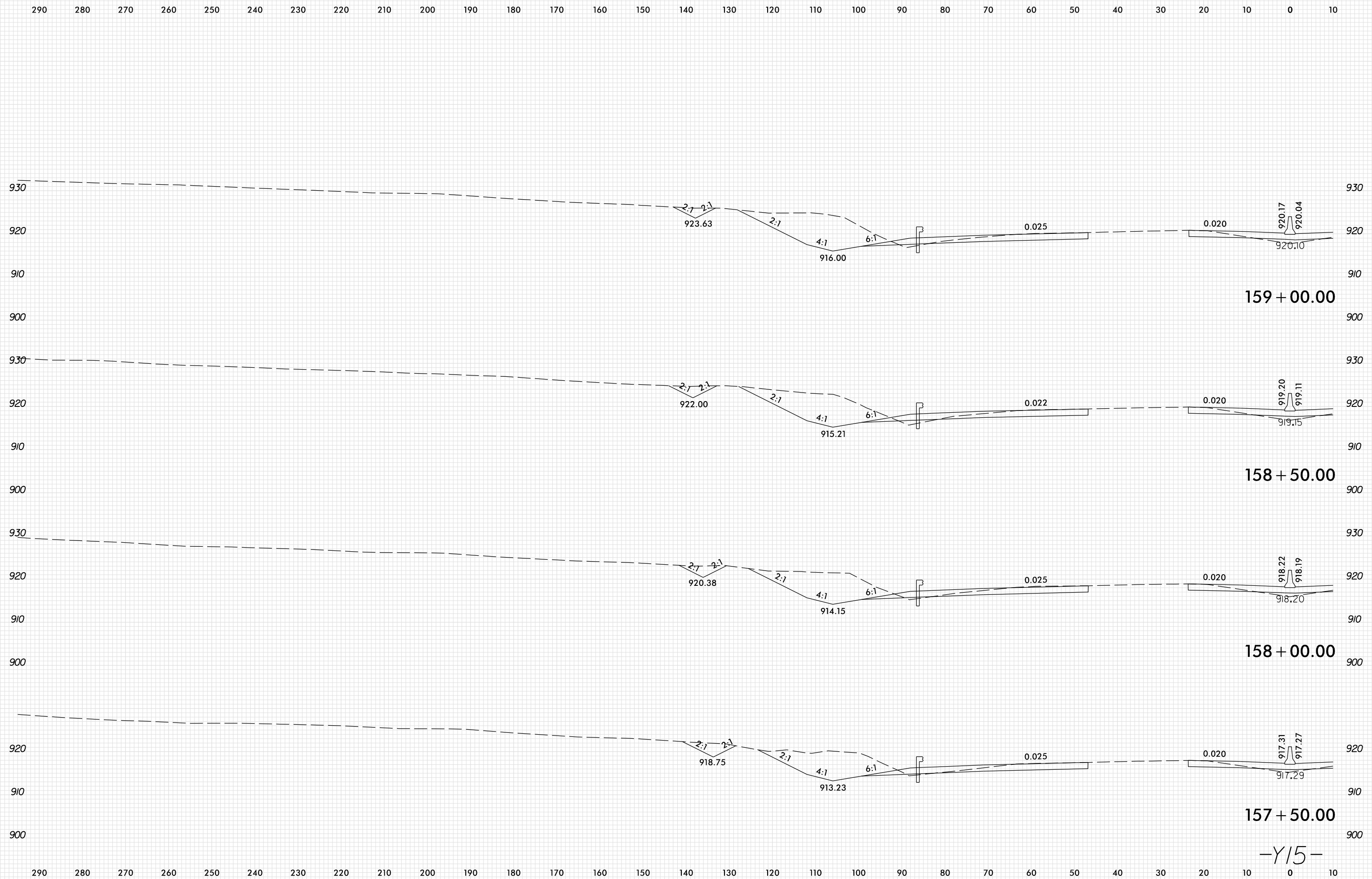

159 + 00.00

158 + 50.00

158 + 00.00

157 + 50.00

-Y15-

PLOT DRIVER: NCD01_pdf_color_eng_100.plt
 USER: SPEREIRA
 DATE: 6/10/2021
 TIME: 2:24:44 PM
 FILE: \

8/23/99

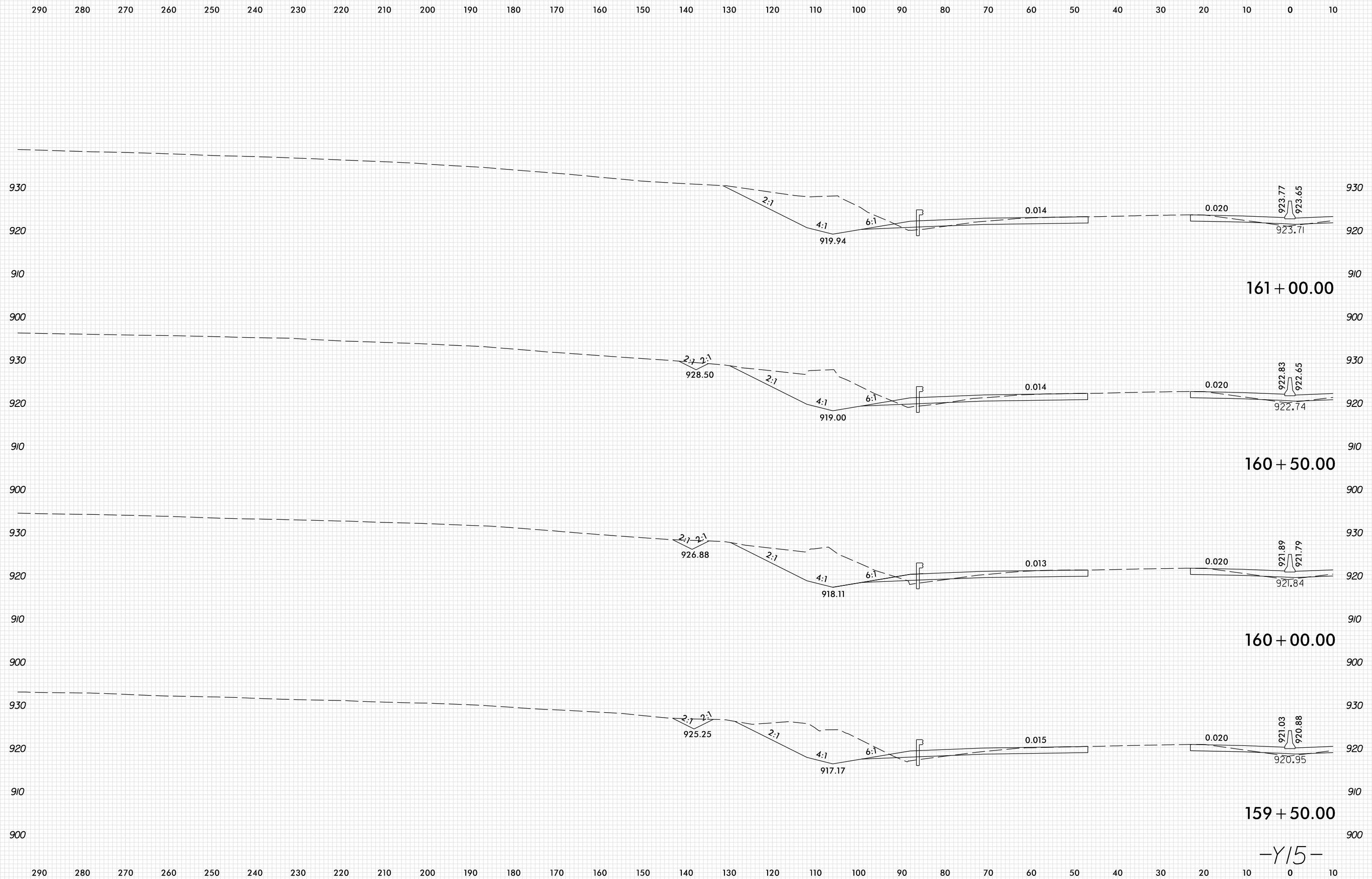

PLOT DRIVER: NCD01_pdf_color_eng_100.plt
 USER: SPEREIRA
 DATE: 6/10/2021
 TIME: 2:24:45 PM

8/23/99

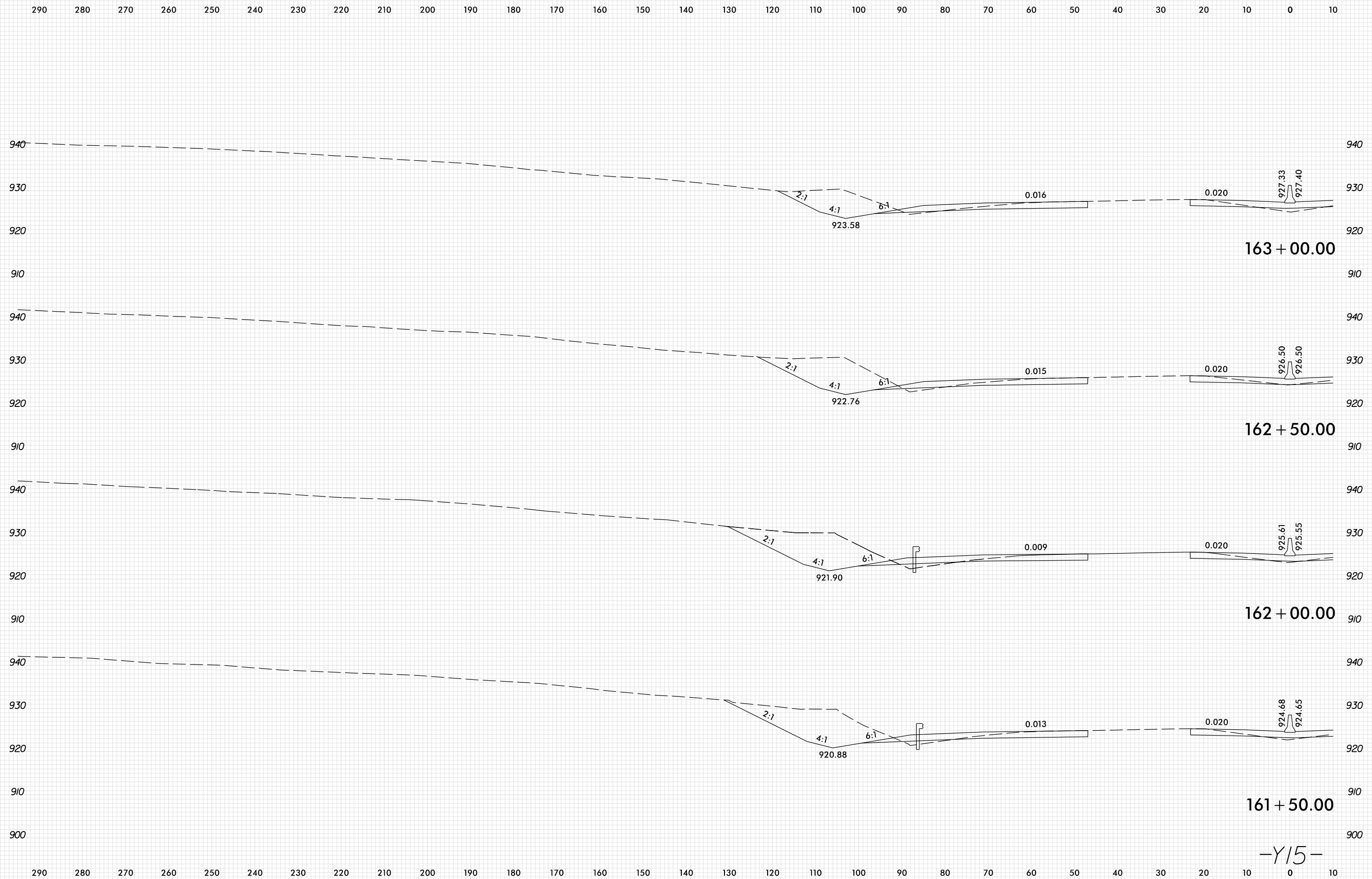

PLOT DRIVER: NCD01.pdf_color_eng_100.plt
 USER: SPEREIRA
 DATE: 6/10/2021
 TIME: 2:24:45 PM
 FILE: \

8/23/99

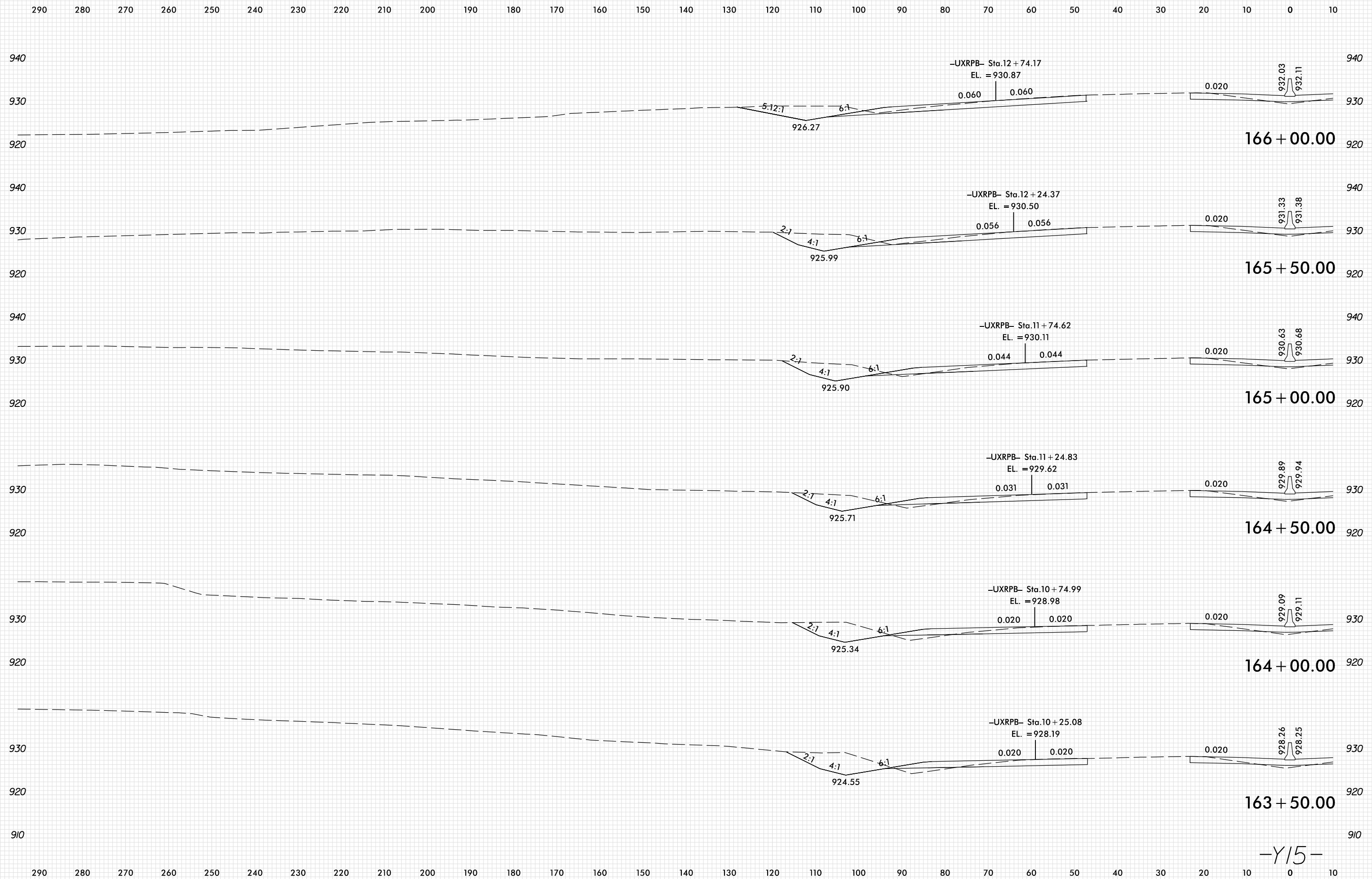

PLOT DRIVER: NCDOT_pdf_color_eng_100.plt
 USER: SPEREIRA
 DATE: 6/10/2021
 TIME: 2:24:46 PM
 FILE: \

8/23/99

290 280 270 260 250 240 230 220 210 200 190 180 170 160 150 140 130 120 110 100 90 80 70 60 50 40 30 20 10 0 10

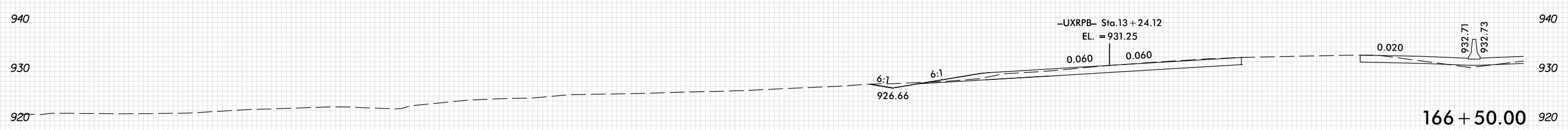
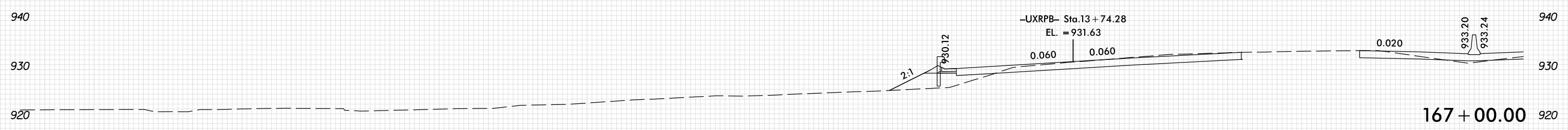
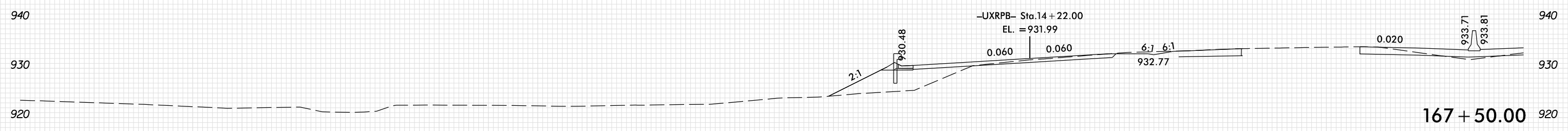
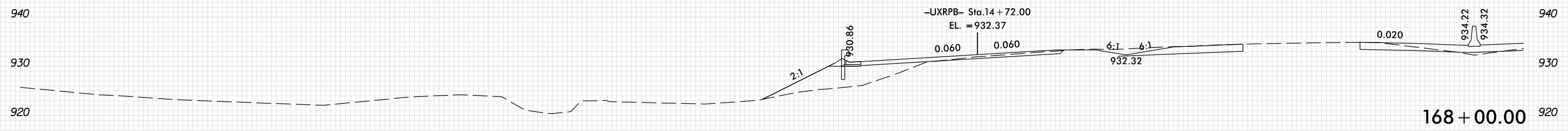

-Y15-

290 280 270 260 250 240 230 220 210 200 190 180 170 160 150 140 130 120 110 100 90 80 70 60 50 40 30 20 10 0 10

PLOT DRIVER: NCD01_pdf_color_eng_100.plt
USER: SPEREIRA
DATE: 6/10/2021
TIME: 2:24:46 PM
FILE: \

8/23/99

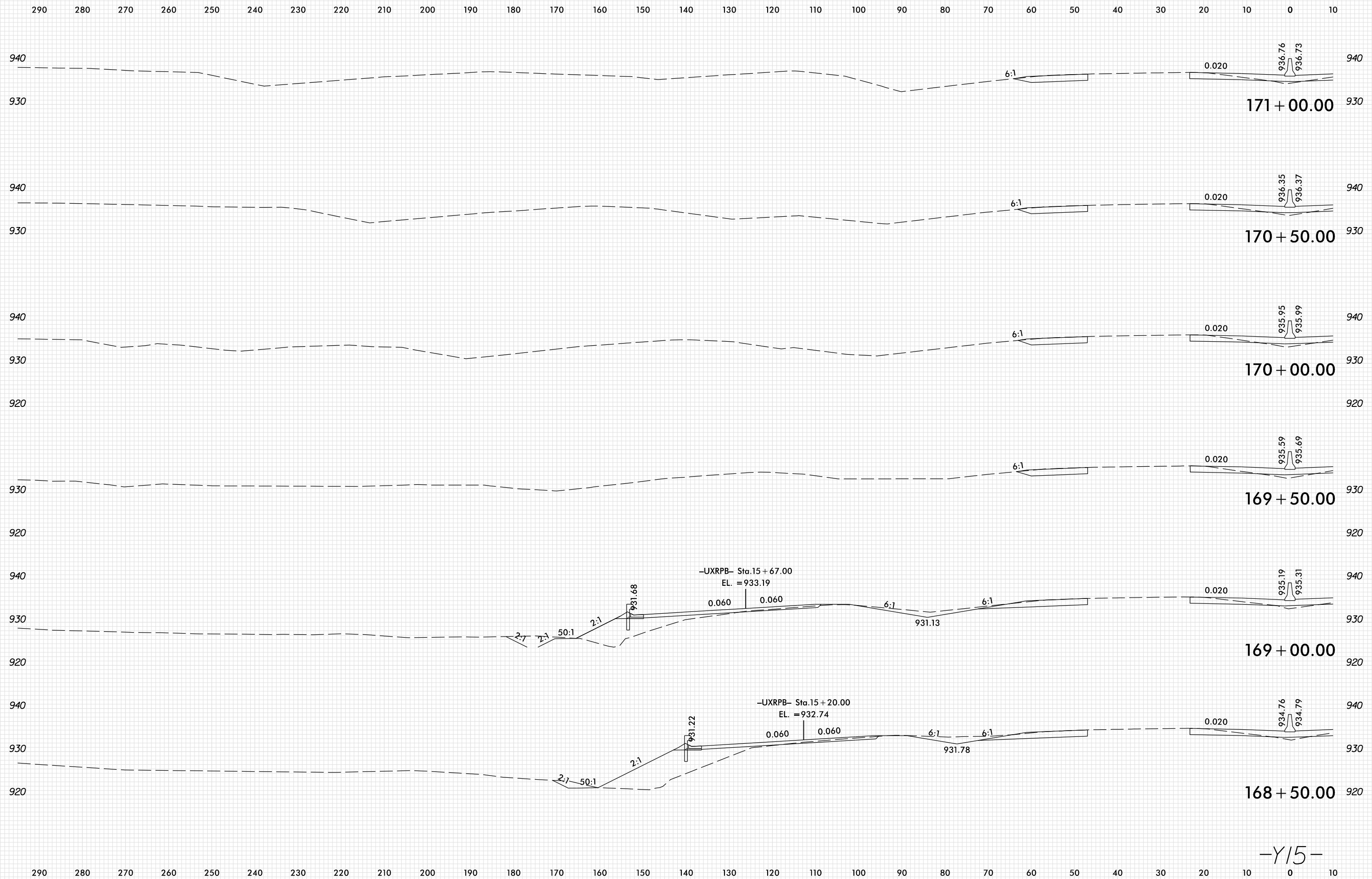

PLOT DRIVER: NCD01_pdf_color_eng_100.plt
 USER: SPEREIRA
 DATE: 6/10/2021
 TIME: 2:24:47 PM
 FILE: \

-Y15-

8/23/99

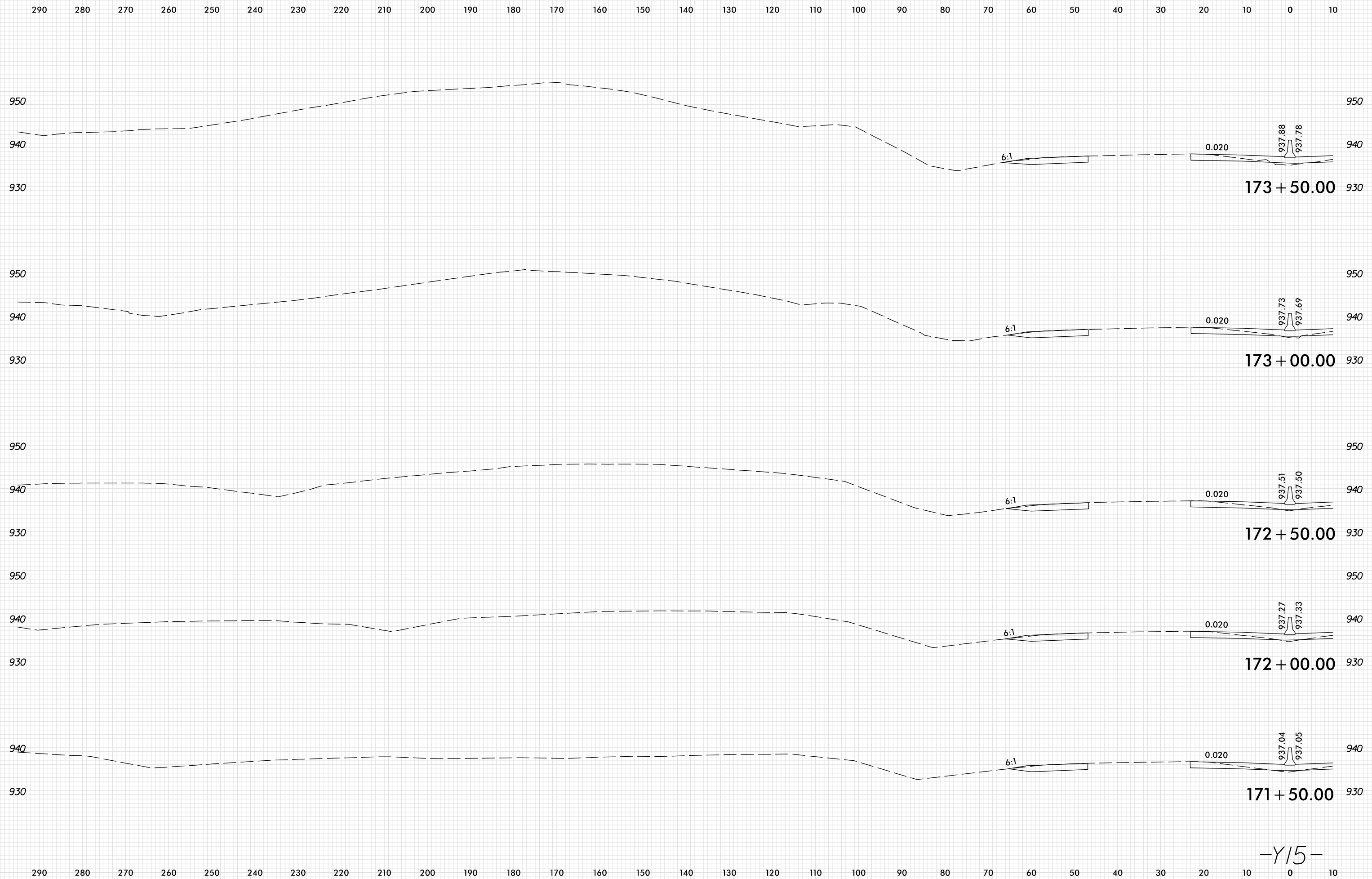

PLOT DRIVER: NCDOT_pdf_color_eng_100.plt
 USER: SPEREIRA
 DATE: 6/10/2021
 TIME: 2:24:48 PM
 FILE: \

8/23/99

0 5 10	PROJ. REFERENCE NO.	SHEET NO.
	U-2579AB	X-385

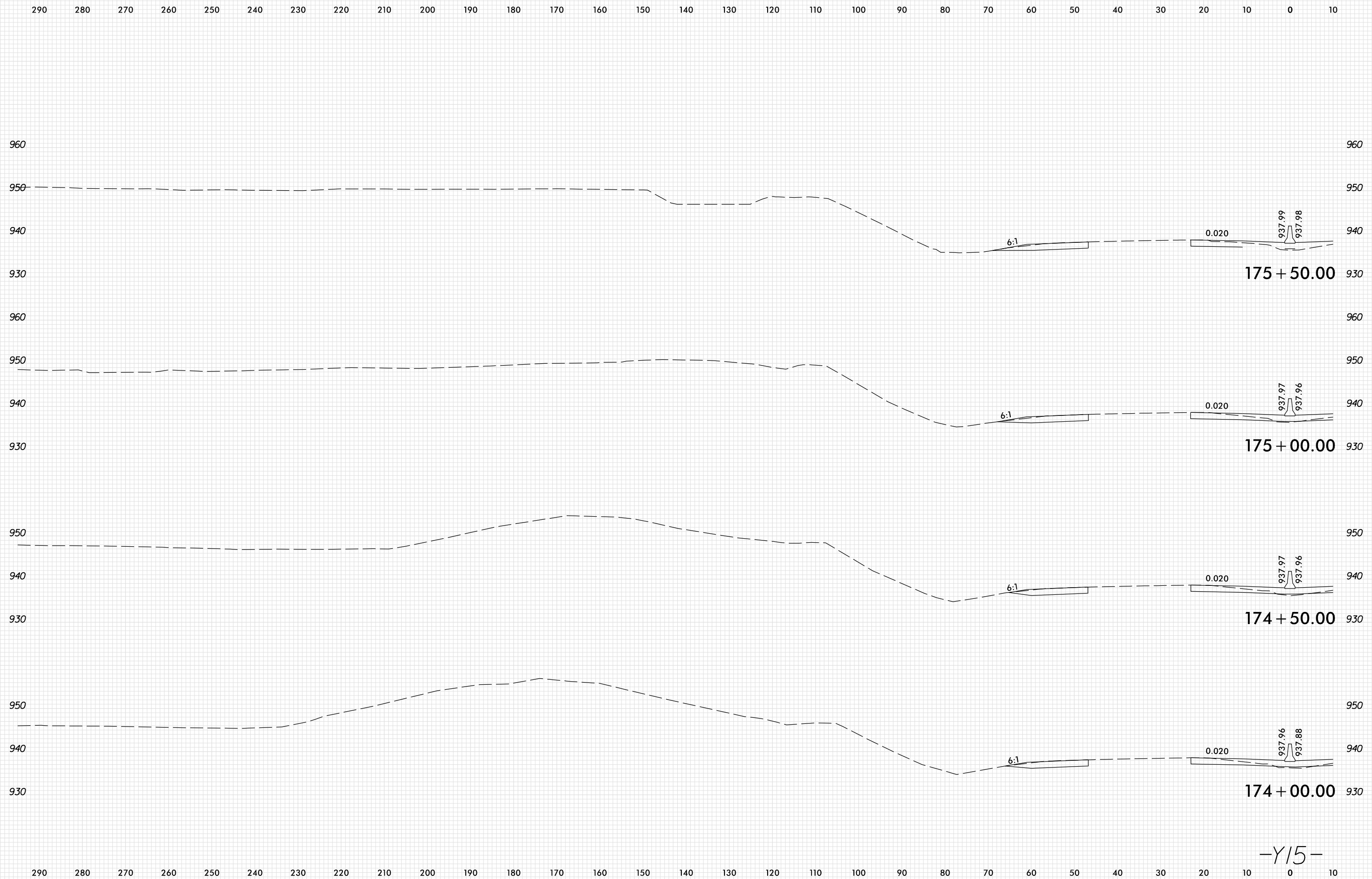

PLOT DRIVER: NCDOT_pdf_color_eng_100.plt
 USER: SPEREIRA
 DATE: 6/10/2021
 TIME: 2:24:49 PM

-Y15-

8/23/99

0 5 10	PROJ. REFERENCE NO.	SHEET NO.
	U-2579AB	X-386

290 280 270 260 250 240 230 220 210 200 190 180 170 160 150 140 130 120 110 100 90 80 70 60 50 40 30 20 10 0 10

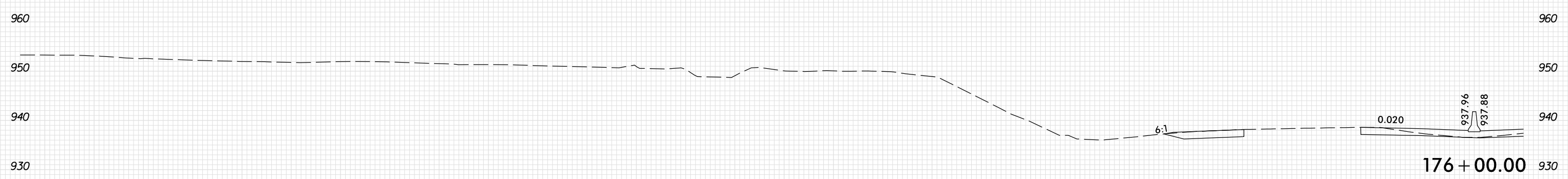
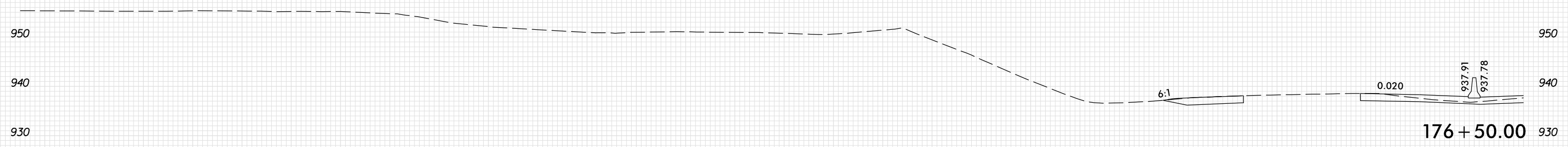
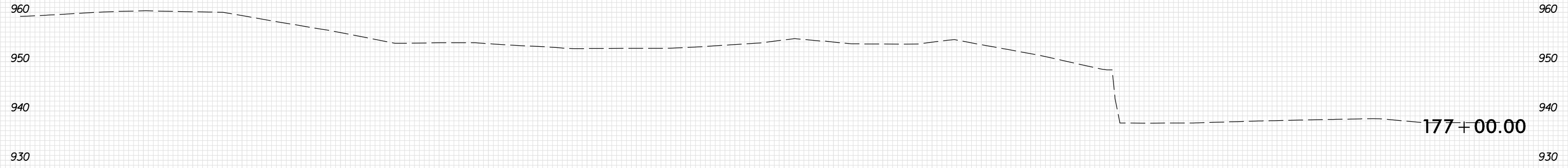

-Y15-

PLOT DRIVER: NCDOT_pdf_color_eng_100.plt
 USER: SPEREIRA
 DATE: 6/10/2021
 TIME: 2:24:49 PM
 FILE: \

290 280 270 260 250 240 230 220 210 200 190 180 170 160 150 140 130 120 110 100 90 80 70 60 50 40 30 20 10 0 10

8/23/99

10 0 10 20 30 40 50 60 70 80 90 100 110 120 130 140 150 160 170 180 190 200 210 220 230 240 250 260 270 280 290

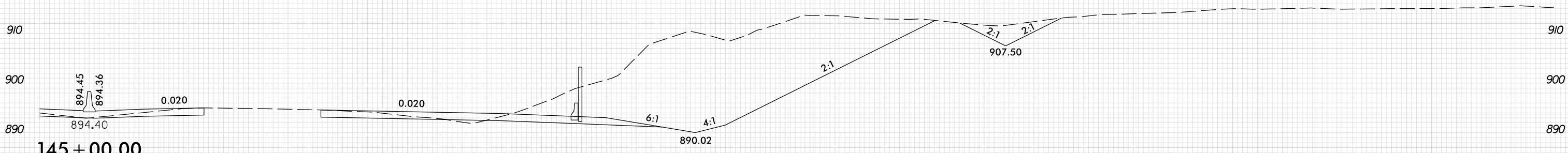
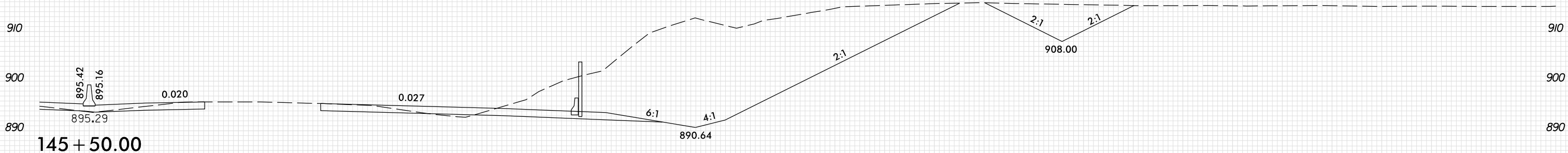
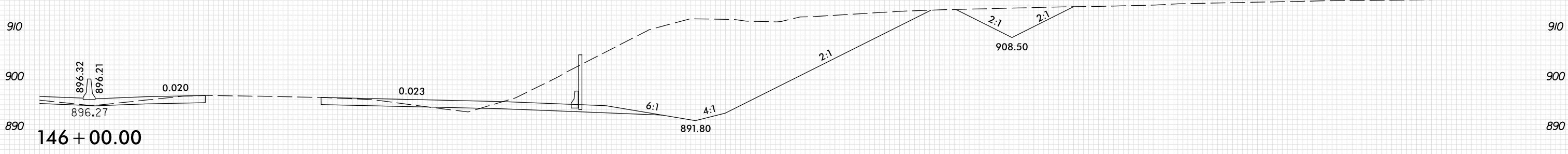
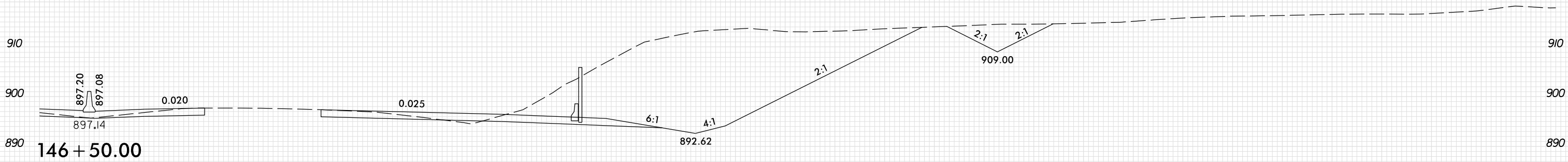

-Y15-

10 0 10 20 30 40 50 60 70 80 90 100 110 120 130 140 150 160 170 180 190 200 210 220 230 240 250 260 270 280 290

PLOT DRIVER: NCD01_pdf_color_eng_100.plt
USER: SPEREIRA
DATE: 6/10/2021
TIME: 2:25:06 PM
FILE: \

8/23/99

0 5 10	PROJ. REFERENCE NO.	SHEET NO.
	U-2579AB	X-388

10 0 10 20 30 40 50 60 70 80 90 100 110 120 130 140 150 160 170 180 190 200 210 220 230 240 250 260 270 280 290

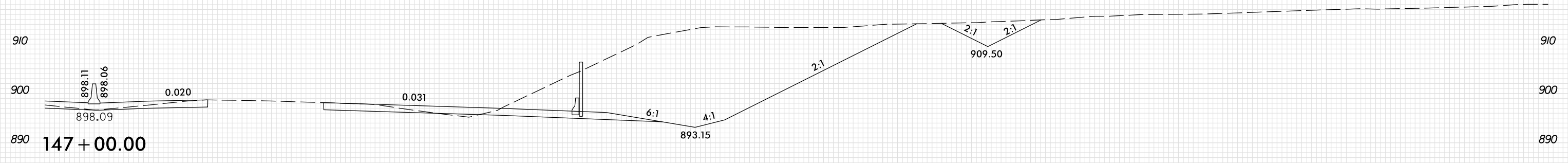
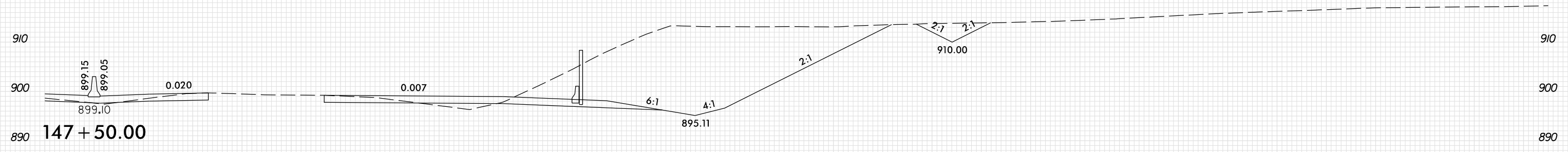
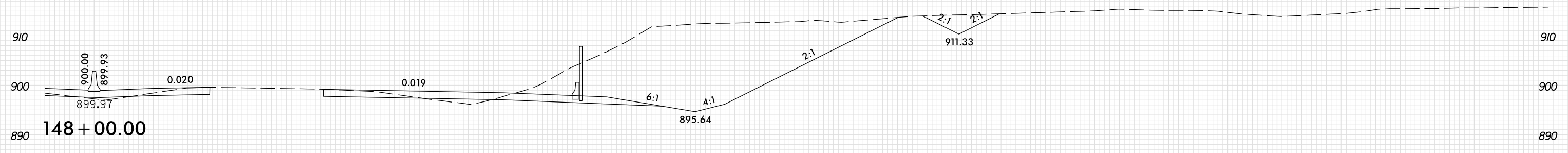
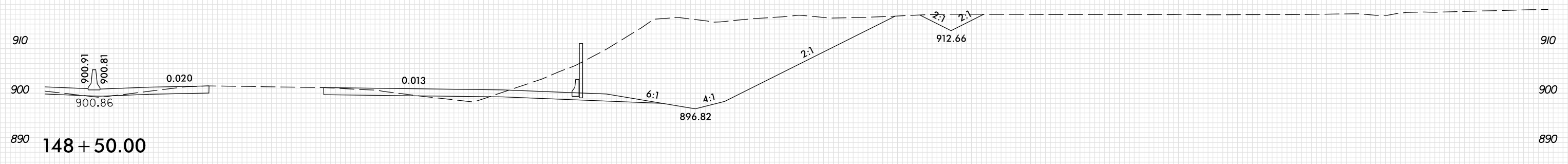

-Y15-

10 0 10 20 30 40 50 60 70 80 90 100 110 120 130 140 150 160 170 180 190 200 210 220 230 240 250 260 270 280 290

PLOT DRIVER: NCD01_pdf_color_eng_100.plt
 USER: SPEREIRA
 DATE: 6/10/2021
 TIME: 2:25:07 PM
 FILE: \

8/23/99

10 0 10 20 30 40 50 60 70 80 90 100 110 120 130 140 150 160 170 180 190 200 210 220 230 240 250 260 270 280 290

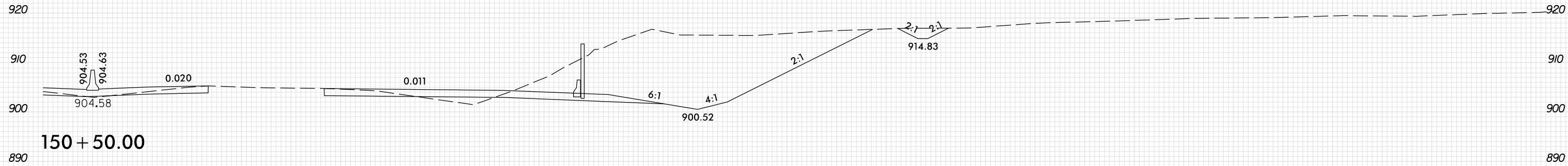

150 + 50.00

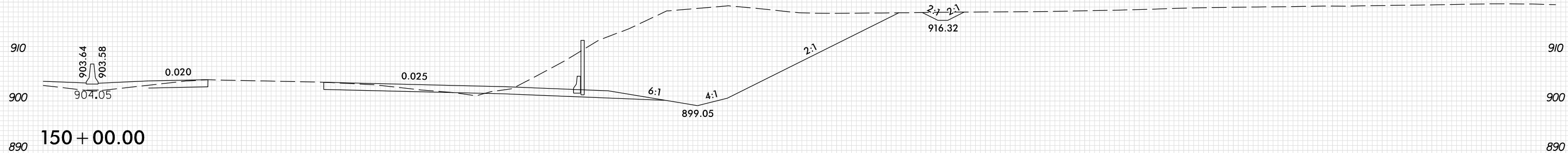

150 + 00.00

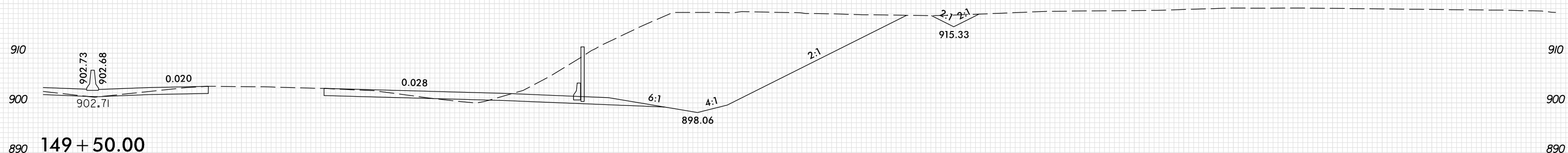

149 + 50.00

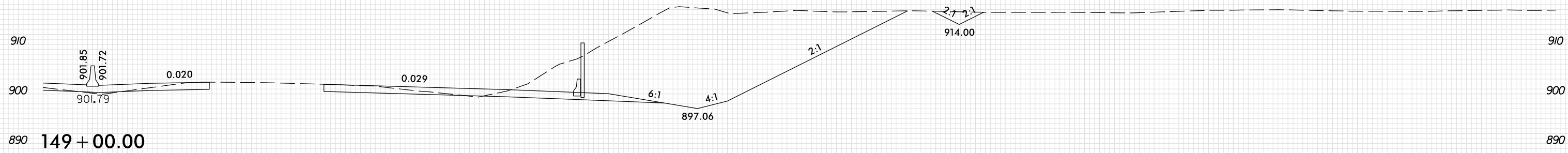

149 + 00.00

-Y15-

10 0 10 20 30 40 50 60 70 80 90 100 110 120 130 140 150 160 170 180 190 200 210 220 230 240 250 260 270 280 290

PLOT DRIVER: NCDOT_pdf_color_eng_100.plt
USER: SPEREIRA
DATE: 6/10/2021
TIME: 2:25:08 PM
FILE: \

8/23/99

10 0 10 20 30 40 50 60 70 80 90 100 110 120 130 140 150 160 170 180 190 200 210 220 230 240 250 260 270 280 290

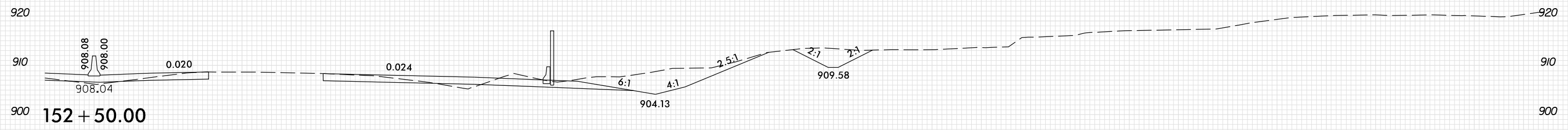

152 + 50.00

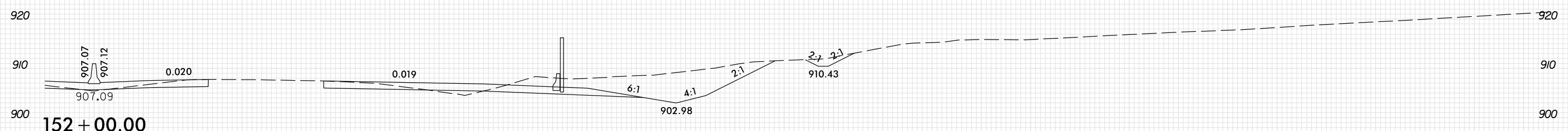

152 + 00.00

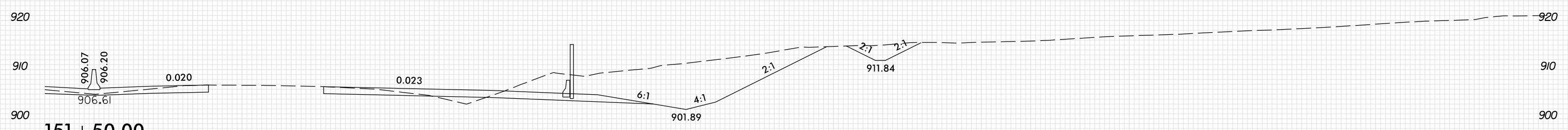

151 + 50.00

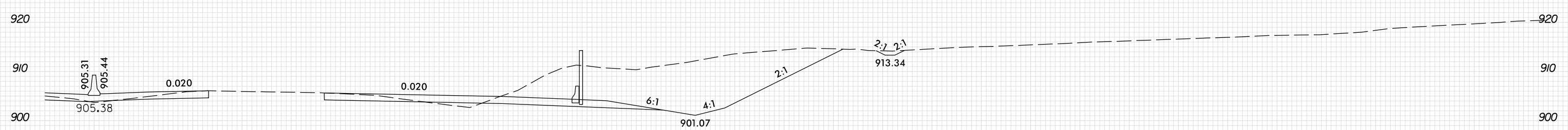

151 + 00.00

-Y15-

10 0 10 20 30 40 50 60 70 80 90 100 110 120 130 140 150 160 170 180 190 200 210 220 230 240 250 260 270 280 290

PLOT DRIVER: NCD01_pdf_color_eng_100.plt
USER: SPEREIRA
DATE: 6/10/2021
TIME: 2:25:08 PM
FILE: \

10 0 10 20 30 40 50 60 70 80 90 100 110 120 130 140 150 160 170 180 190 200 210 220 230 240 250 260 270 280 290

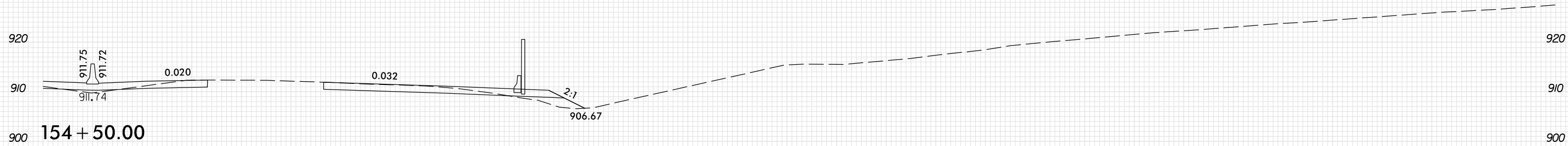

154 + 50.00

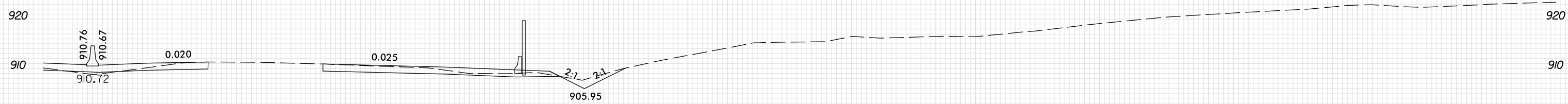

154 + 00.00

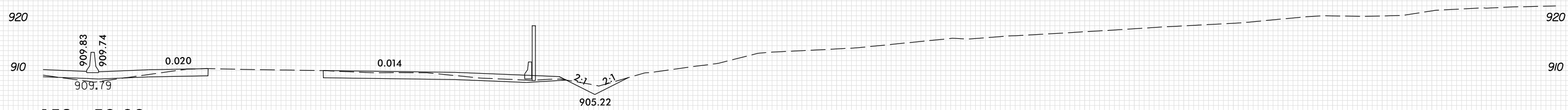

153 + 50.00

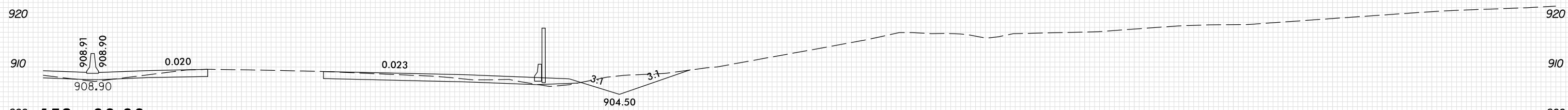

153 + 00.00

-Y15-

10 0 10 20 30 40 50 60 70 80 90 100 110 120 130 140 150 160 170 180 190 200 210 220 230 240 250 260 270 280 290

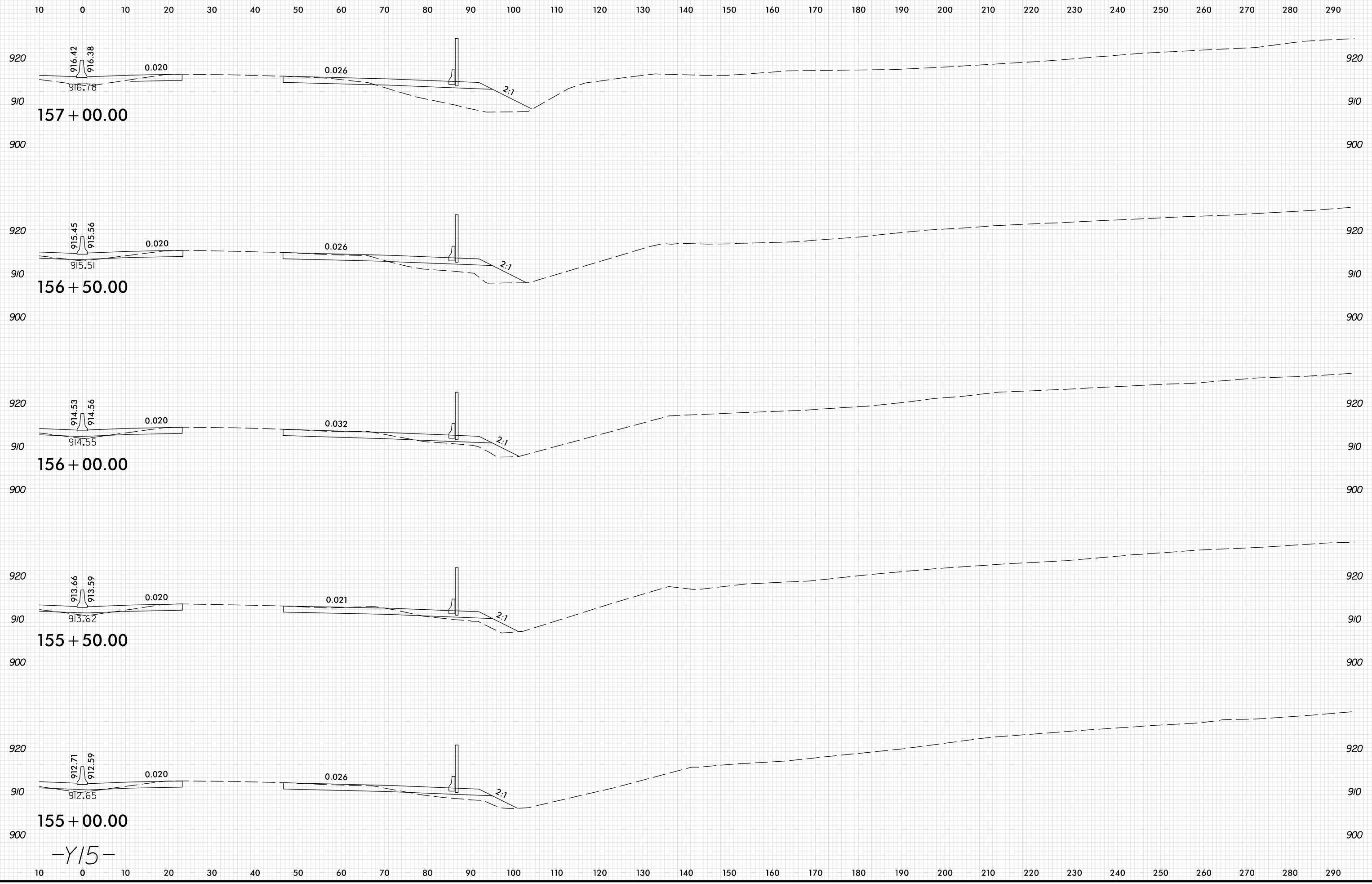

-Y15-

10 0 10 20 30 40 50 60 70 80 90 100 110 120 130 140 150 160 170 180 190 200 210 220 230 240 250 260 270 280 290

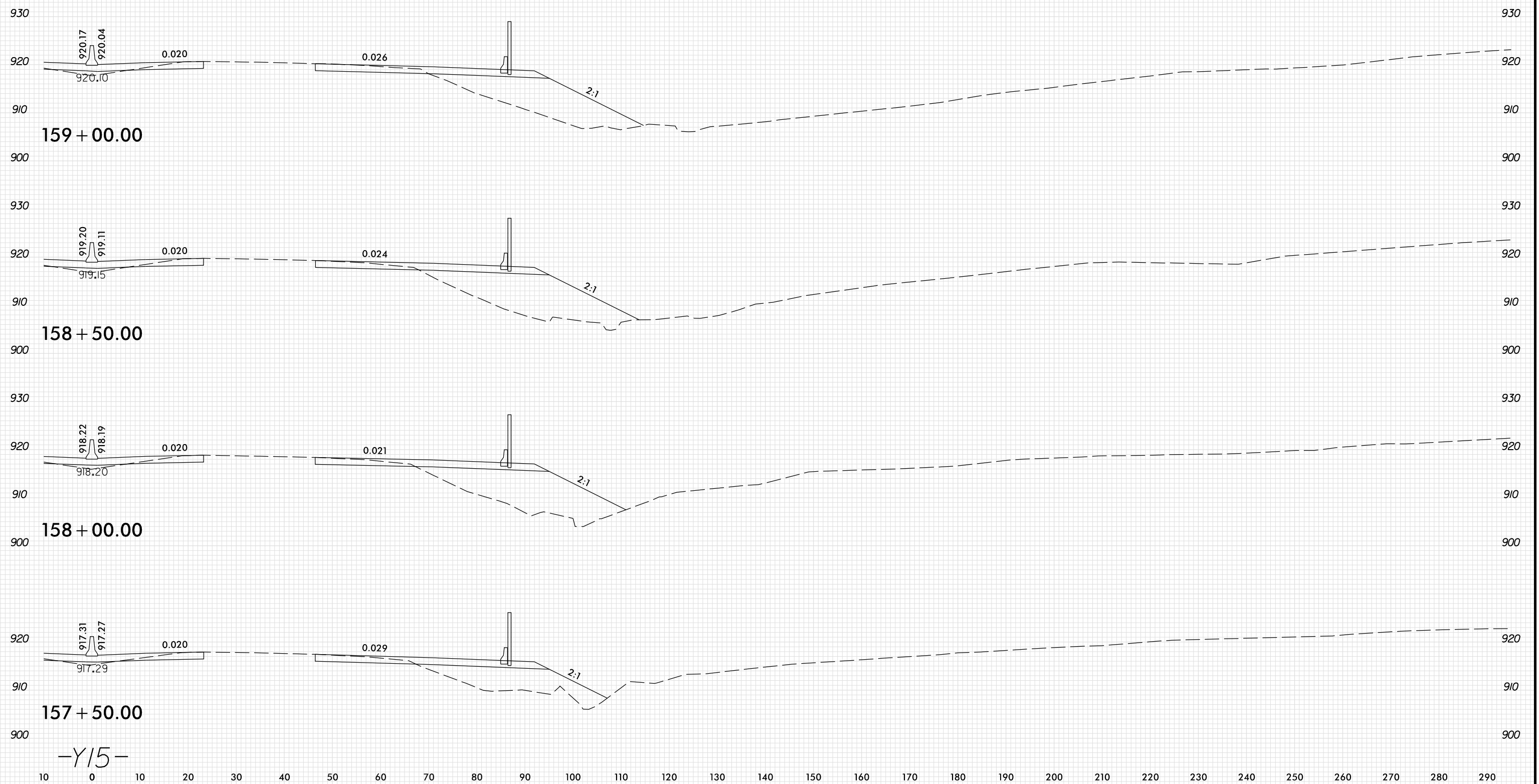

-Y15-

8/23/99

0 5 10	PROJ. REFERENCE NO.	SHEET NO.
	U-2579AB	X-394

10 0 10 20 30 40 50 60 70 80 90 100 110 120 130 140 150 160 170 180 190 200 210 220 230 240 250 260 270 280 290

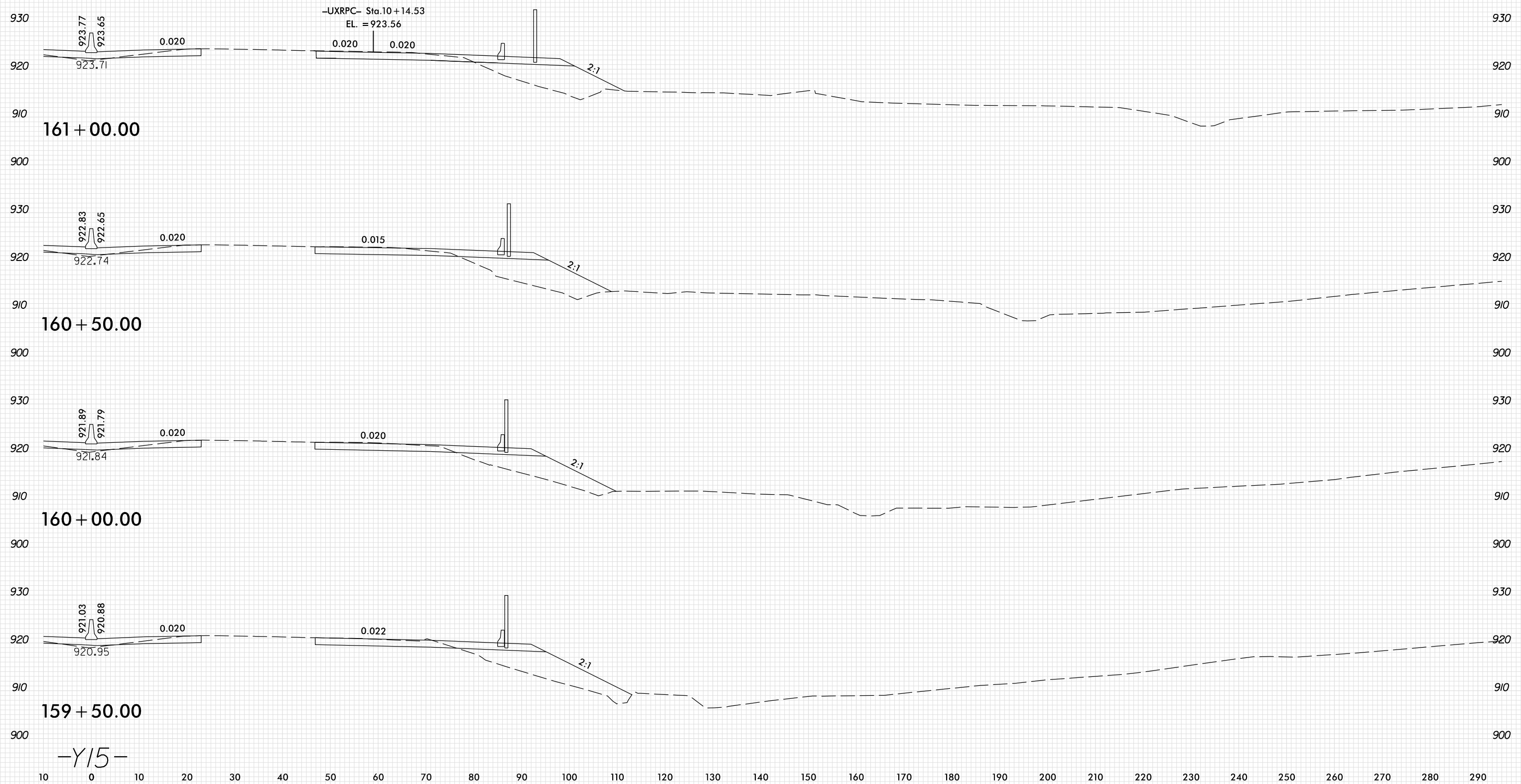

-Y15-

10 0 10 20 30 40 50 60 70 80 90 100 110 120 130 140 150 160 170 180 190 200 210 220 230 240 250 260 270 280 290

PLOT DRIVER: NCD01_pdf_color_eng_100.plt
 USER: SPEREIRA
 DATE: 6/10/2021
 TIME: 2:25:12 PM
 FILE: \

8/23/99

10 0 10 20 30 40 50 60 70 80 90 100 110 120 130 140 150 160 170 180 190 200 210 220 230 240 250 260 270 280 290

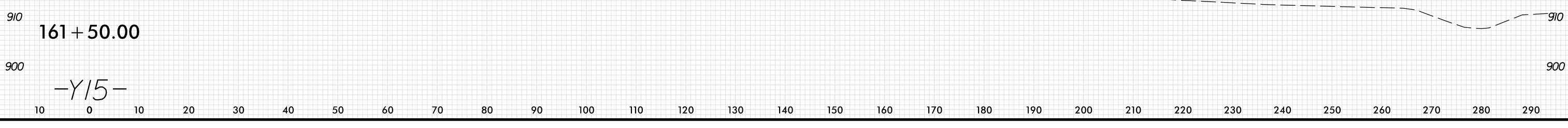
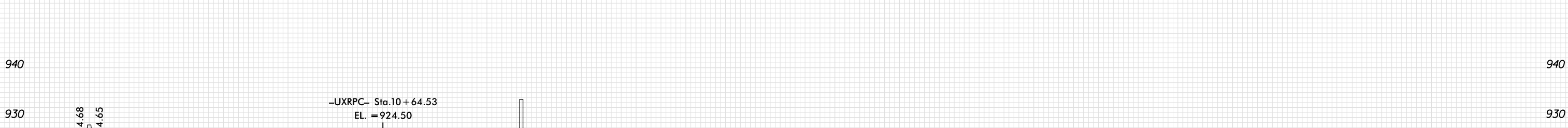
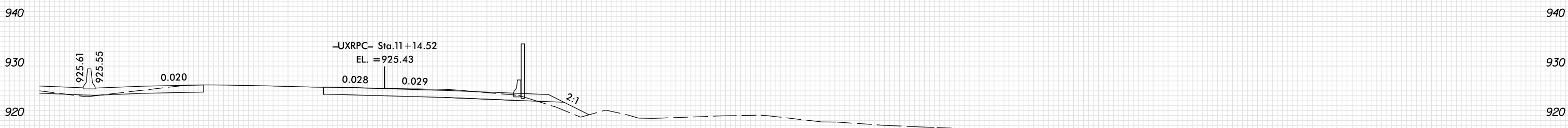
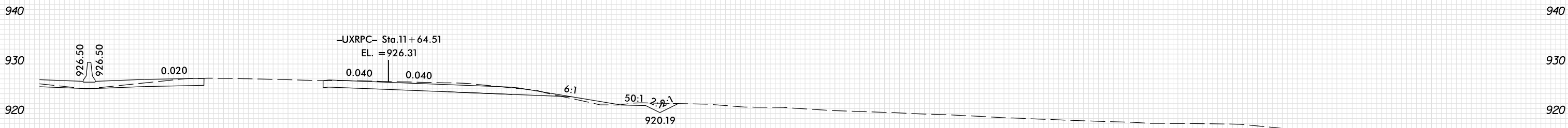
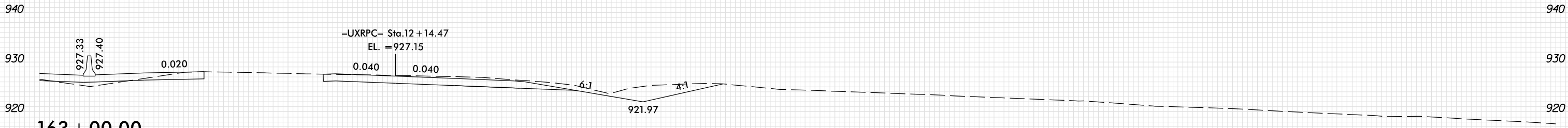

-Y15-

PLOT DRIVER: NCDOT_pdf_color_eng_100.plt
USER: SPEREIRA
DATE: 6/10/2021
TIME: 2:25:13 PM
FILE: \

8/23/99

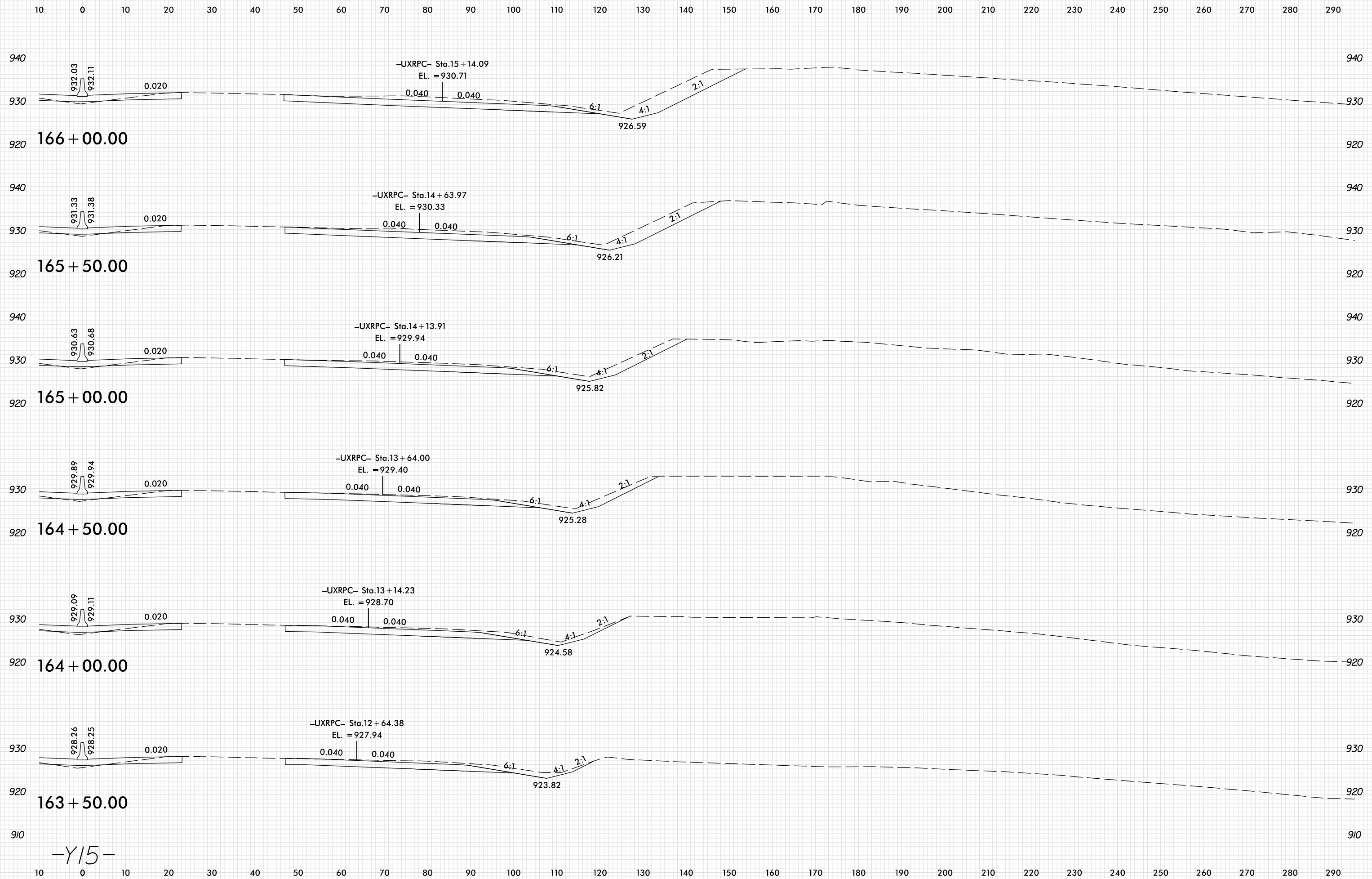

PLOT DRIVER: NCDOT_pdf_color_eng_100.plt
 USER: SPEREIRA
 DATE: 6/10/2021
 TIME: 2:25:13 PM
 FILE: \

-Y15-

8/23/99

10 0 10 20 30 40 50 60 70 80 90 100 110 120 130 140 150 160 170 180 190 200 210 220 230 240 250 260 270 280 290

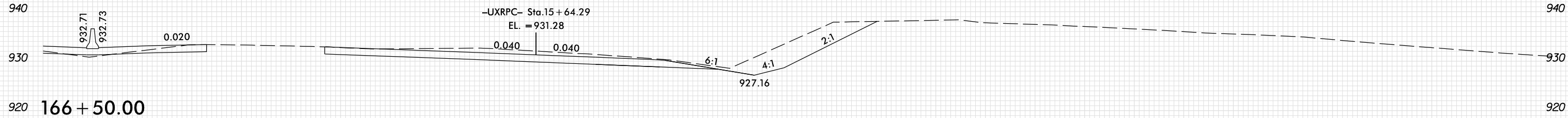
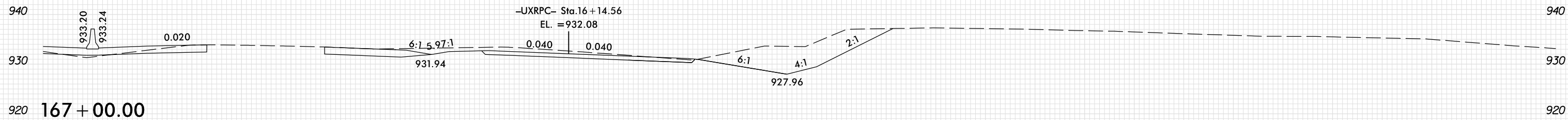
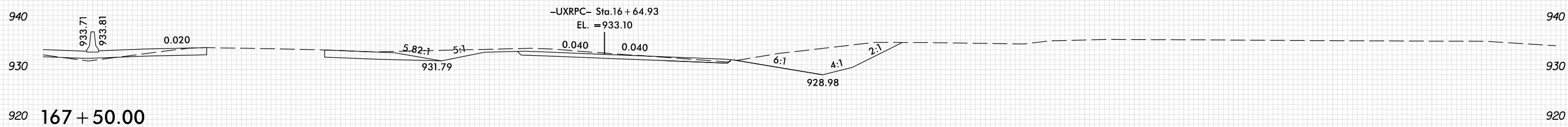
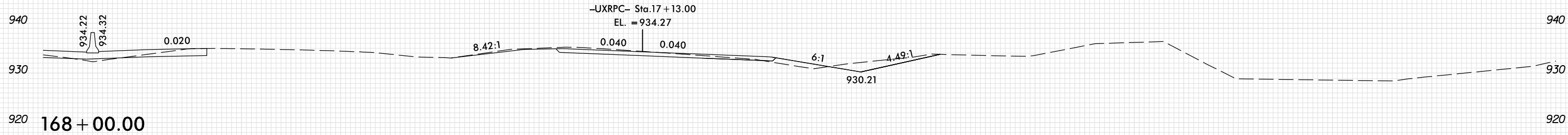

-Y15-

10 0 10 20 30 40 50 60 70 80 90 100 110 120 130 140 150 160 170 180 190 200 210 220 230 240 250 260 270 280 290

PLOT DRIVER: NCDOT_pdf_color_eng_100.plt
USER: SPEREIRA
DATE: 6/10/2021
TIME: 2:25:14 PM
FILE: \

8/23/99

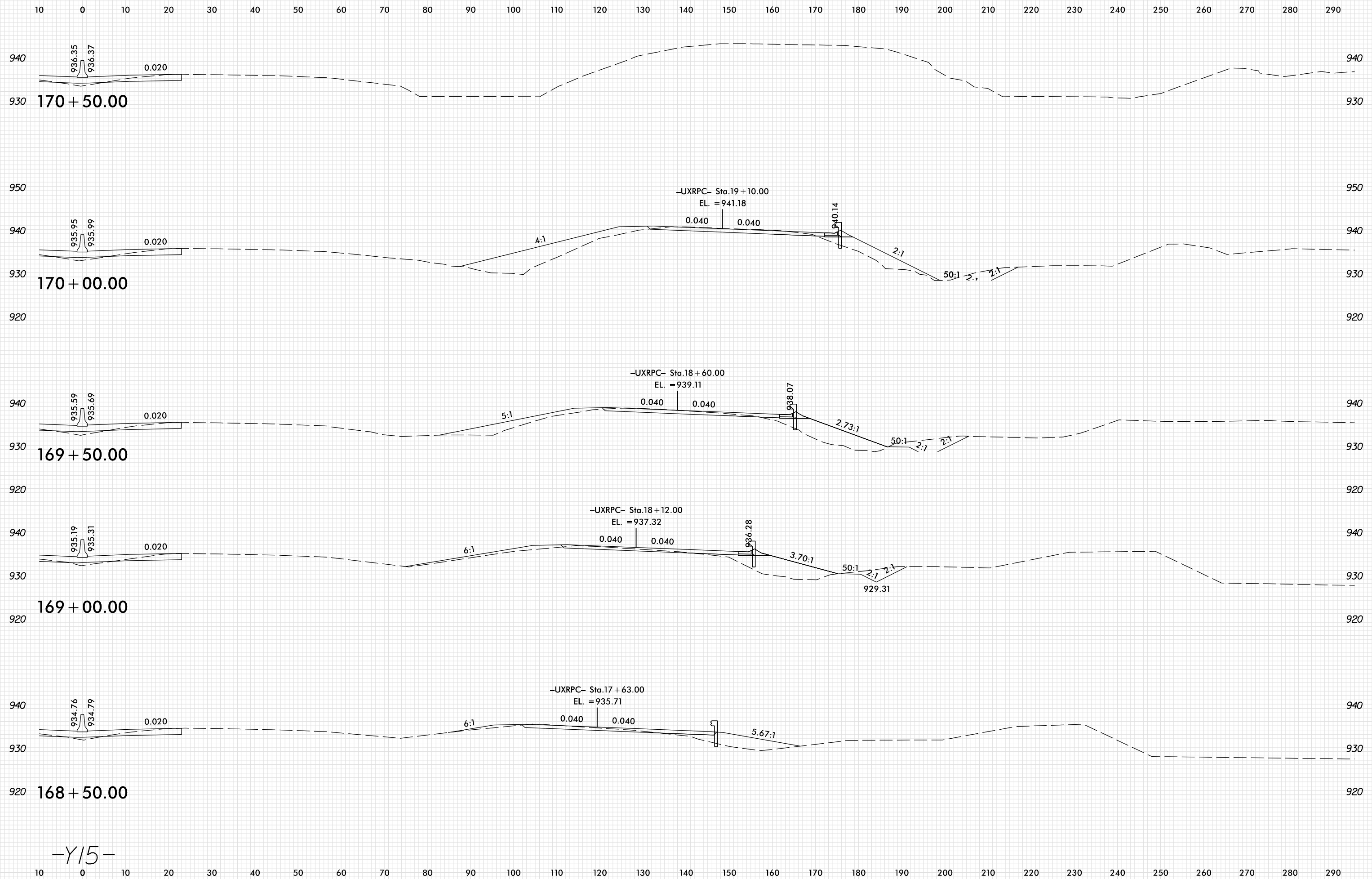

10 0 10 20 30 40 50 60 70 80 90 100 110 120 130 140 150 160 170 180 190 200 210 220 230 240 250 260 270 280 290

PLOT DRIVER: NCDOT_pdf_color_eng_100.plt
 USER: SPEREIRA
 DATE: 6/10/2021
 TIME: 2:25:15 PM
 FILE: \

-Y15-

10 0 10 20 30 40 50 60 70 80 90 100 110 120 130 140 150 160 170 180 190 200 210 220 230 240 250 260 270 280 290

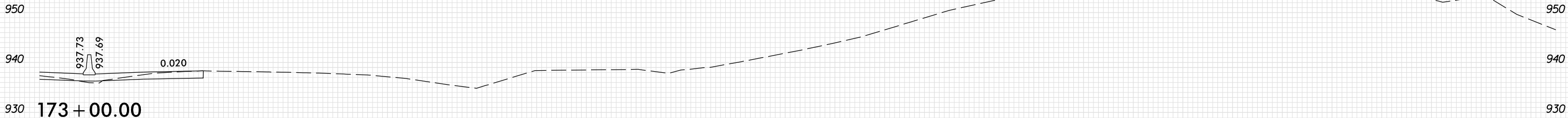

173 + 00.00

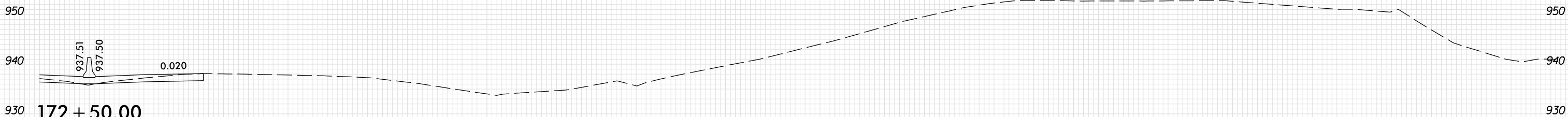

172 + 50.00

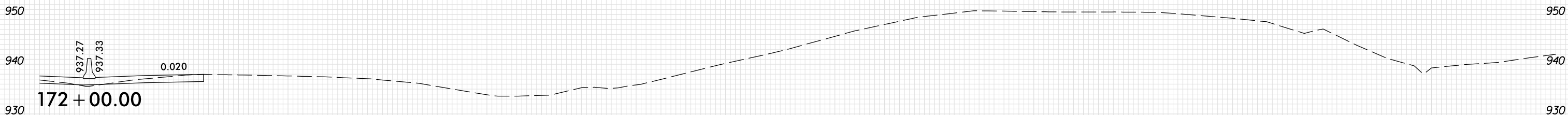

172 + 00.00

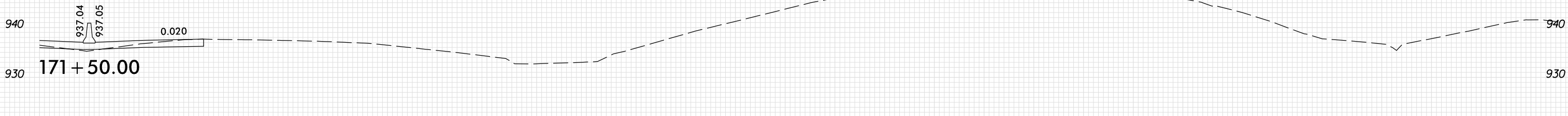

171 + 50.00

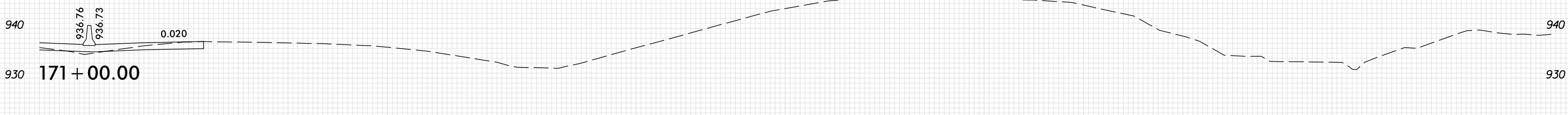

171 + 00.00

-Y15-

10 0 10 20 30 40 50 60 70 80 90 100 110 120 130 140 150 160 170 180 190 200 210 220 230 240 250 260 270 280 290

10 0 10 20 30 40 50 60 70 80 90 100 110 120 130 140 150 160 170 180 190 200 210 220 230 240 250 260 270 280 290

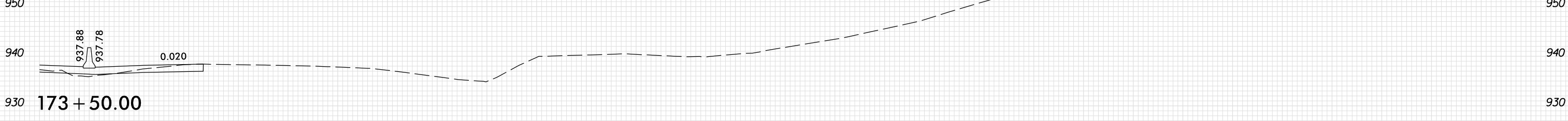
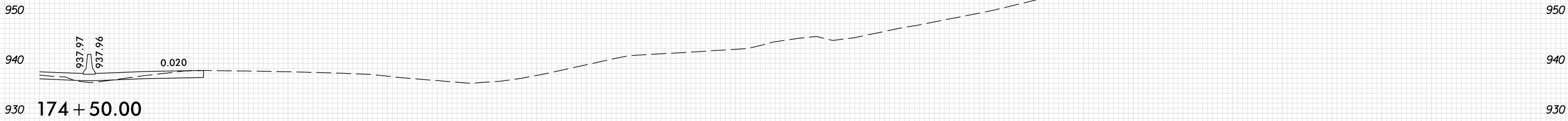
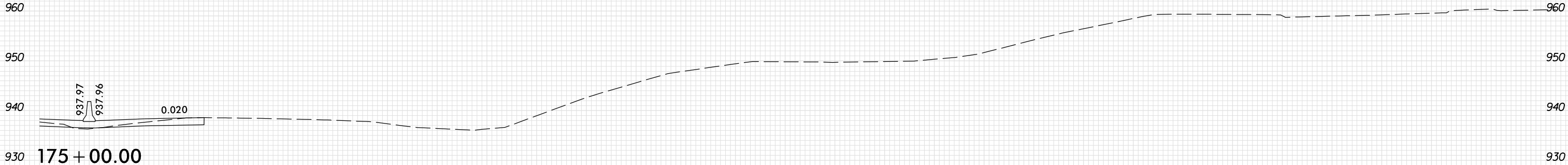

-Y15-

10 0 10 20 30 40 50 60 70 80 90 100 110 120 130 140 150 160 170 180 190 200 210 220 230 240 250 260 270 280 290

8/23/99

0 5 10	PROJ. REFERENCE NO.	SHEET NO.
	U-2579AB	X-401

10 0 10 20 30 40 50 60 70 80 90 100 110 120 130 140 150 160 170 180 190 200 210 220 230 240 250 260 270 280 290

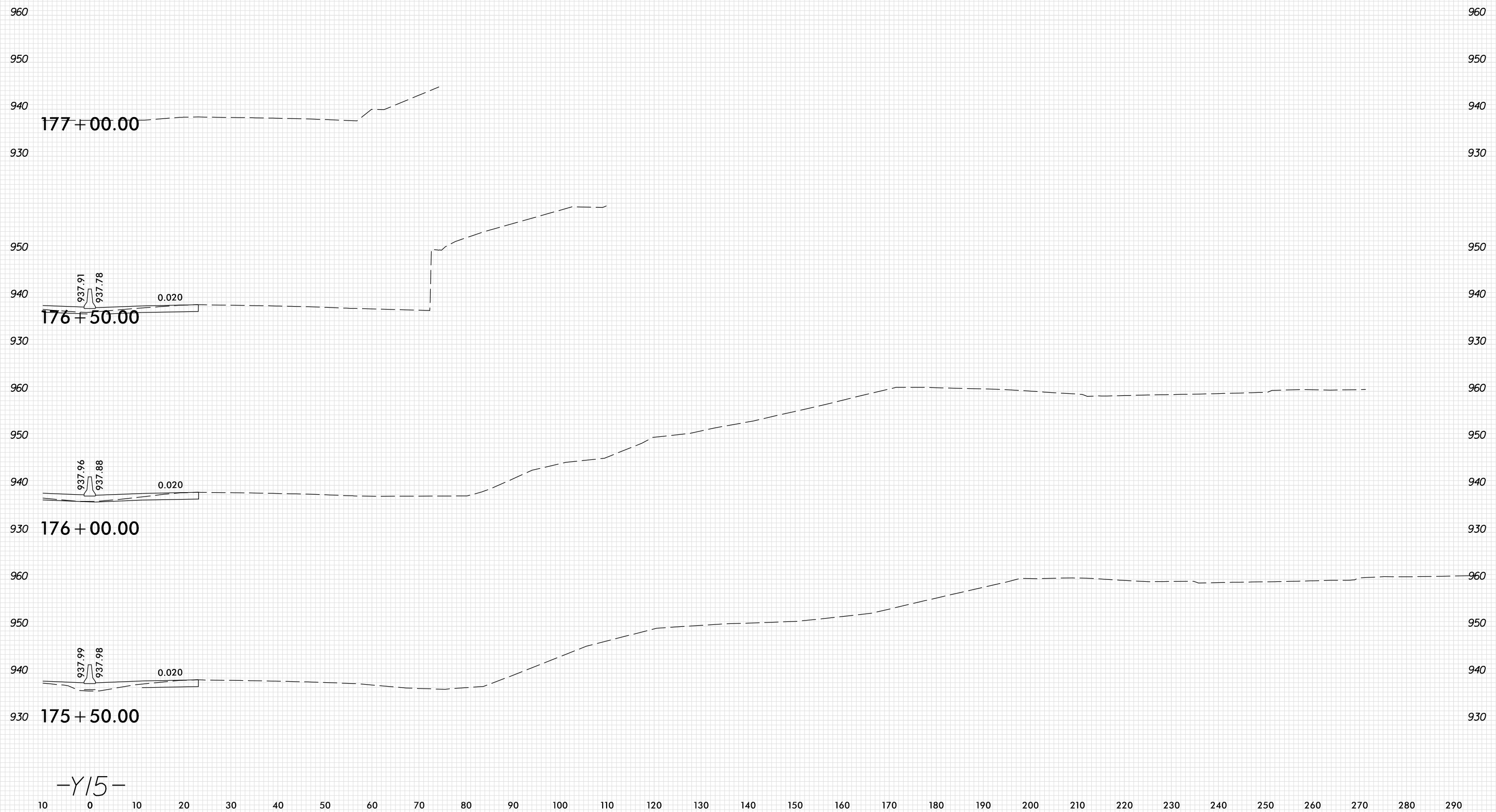

PLOT DRIVER: NCDOT_pdf_color_eng_100.plt
USER: SPEREIRA
DATE: 6/10/2021
TIME: 2:25:17 PM
FILE: \

-Y15-

8/23/99

0 10 20	PROJ. REFERENCE NO.	SHEET NO.
	U-2579AB	X-402

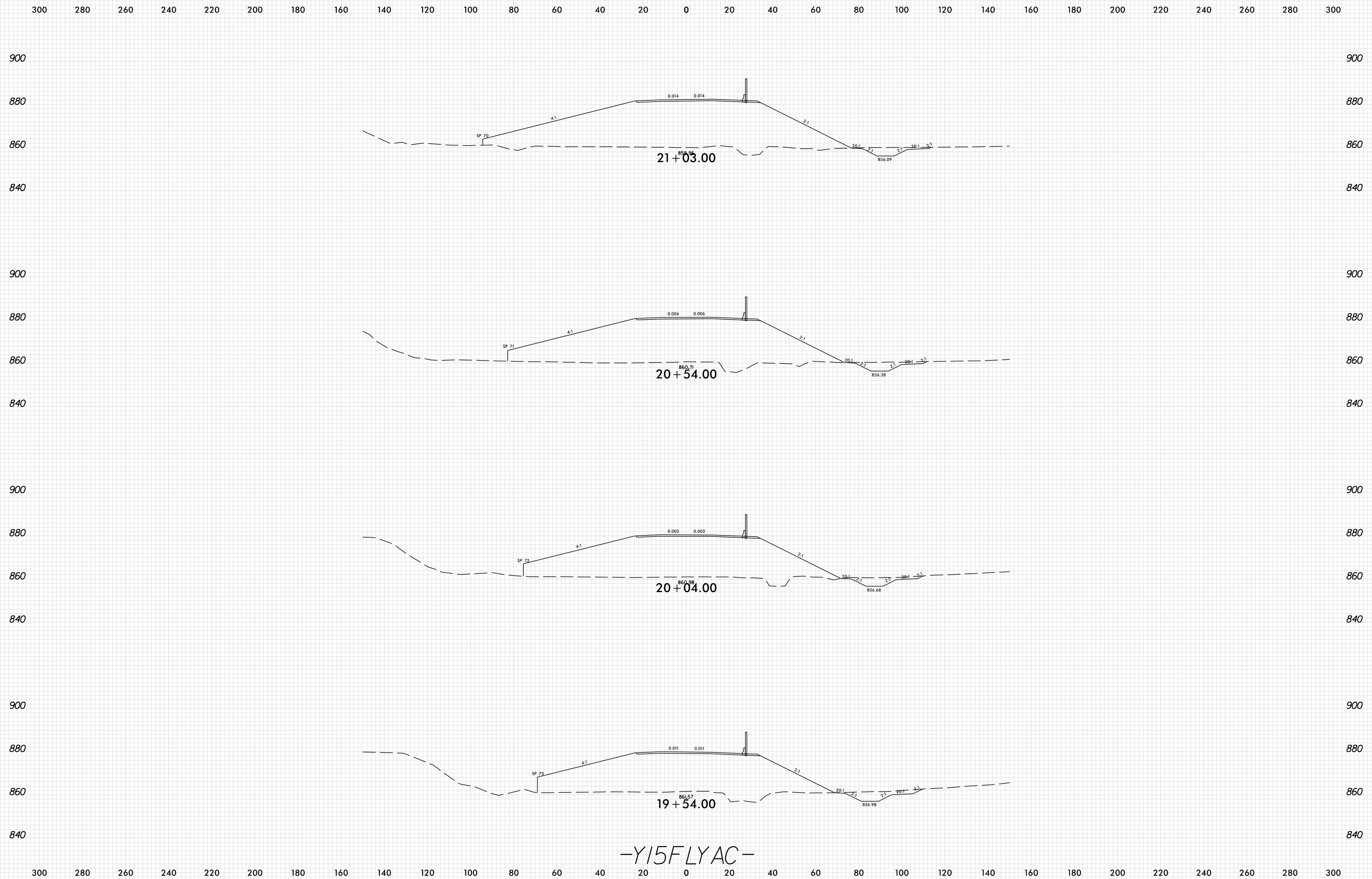

-Y15FLYAC-

PLOT DRIVER: NCD01_pdf_color_eng_100.plt
 USER: SPEREIRA
 DATE: 6/10/2021
 TIME: 2:25:45 PM
 FILE: \

8/23/99

0 10 20	PROJ. REFERENCE NO.	SHEET NO.
	U-2579AB	X-403

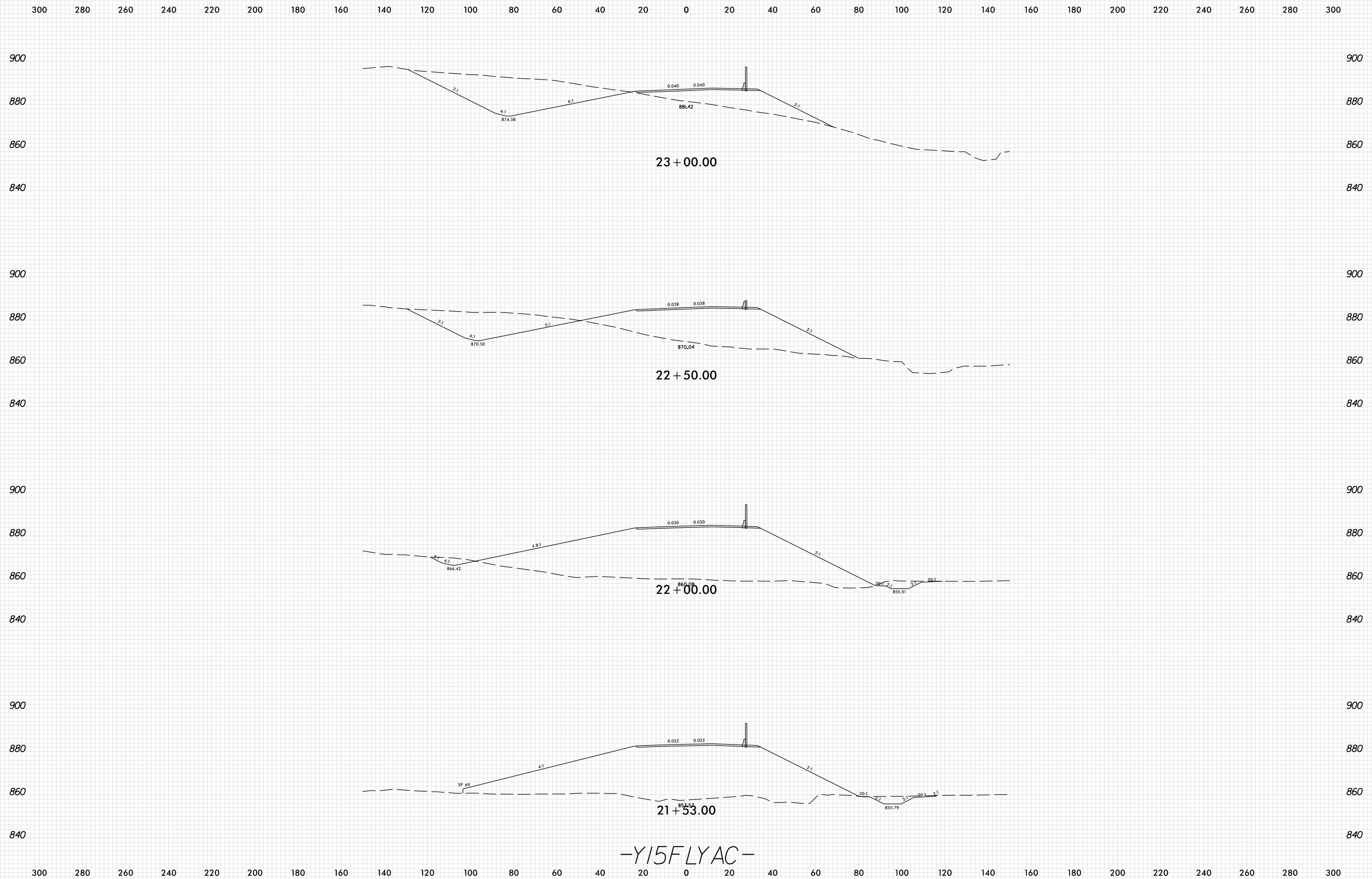

-Y15FLYAC-

PLOT DRIVER: NCD01_pdf_color_eng_100.plt
 USER: SPEREIRA
 DATE: 6/10/2021
 TIME: 2:25:46 PM
 FILE: \

8/23/99

0 10 20	PROJ. REFERENCE NO.	SHEET NO.
	U-2579AB	X-404

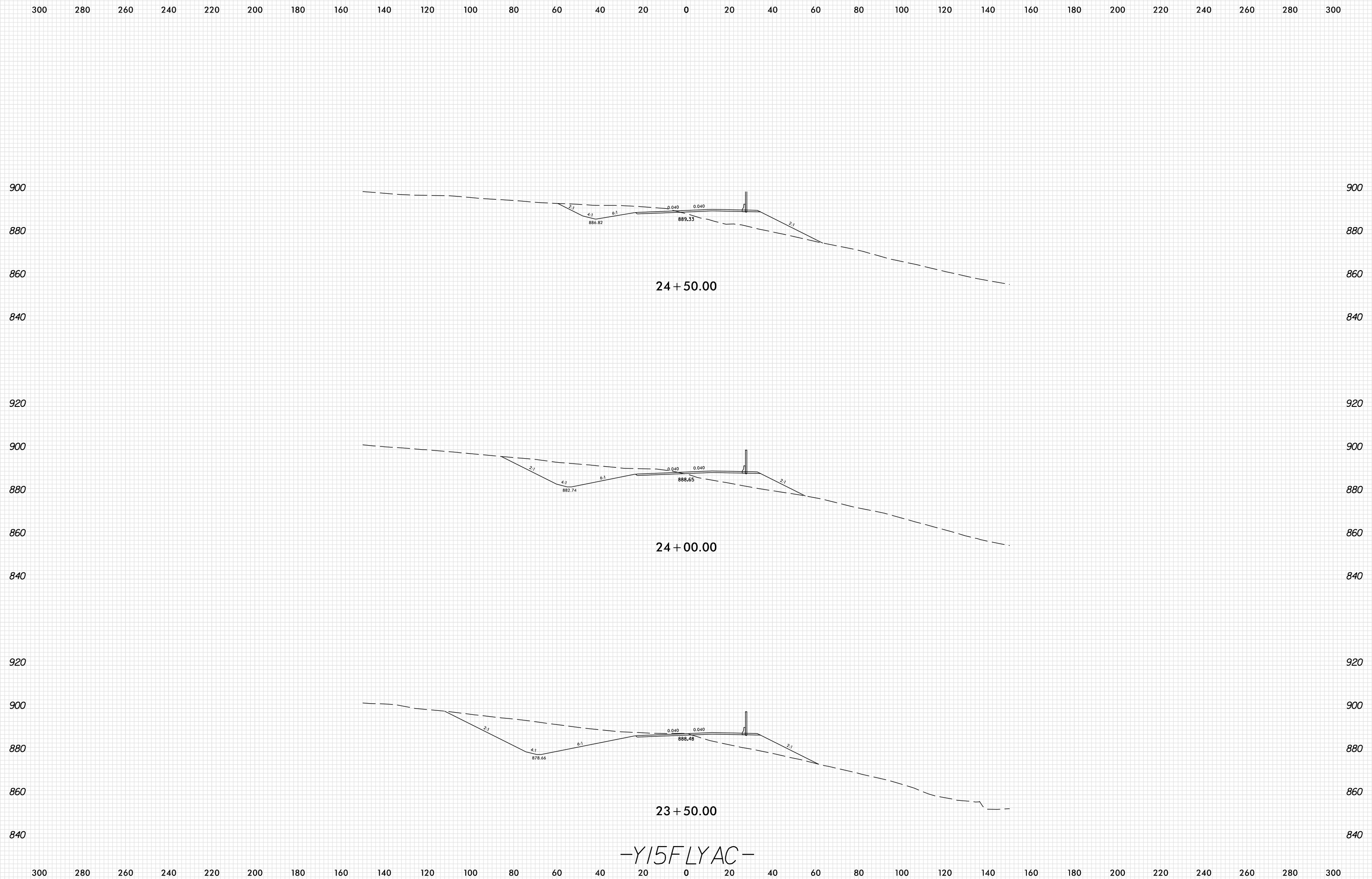

-Y15FLYAC-

PLOT DRIVER: NCD01_pdf_color_eng_100.plt
 USER: SPEREIRA
 DATE: 6/10/2021
 TIME: 2:25:47 PM
 FILE: \

8/23/99

0 10 20	PROJ. REFERENCE NO.	SHEET NO.
	U-2579AB	X-405

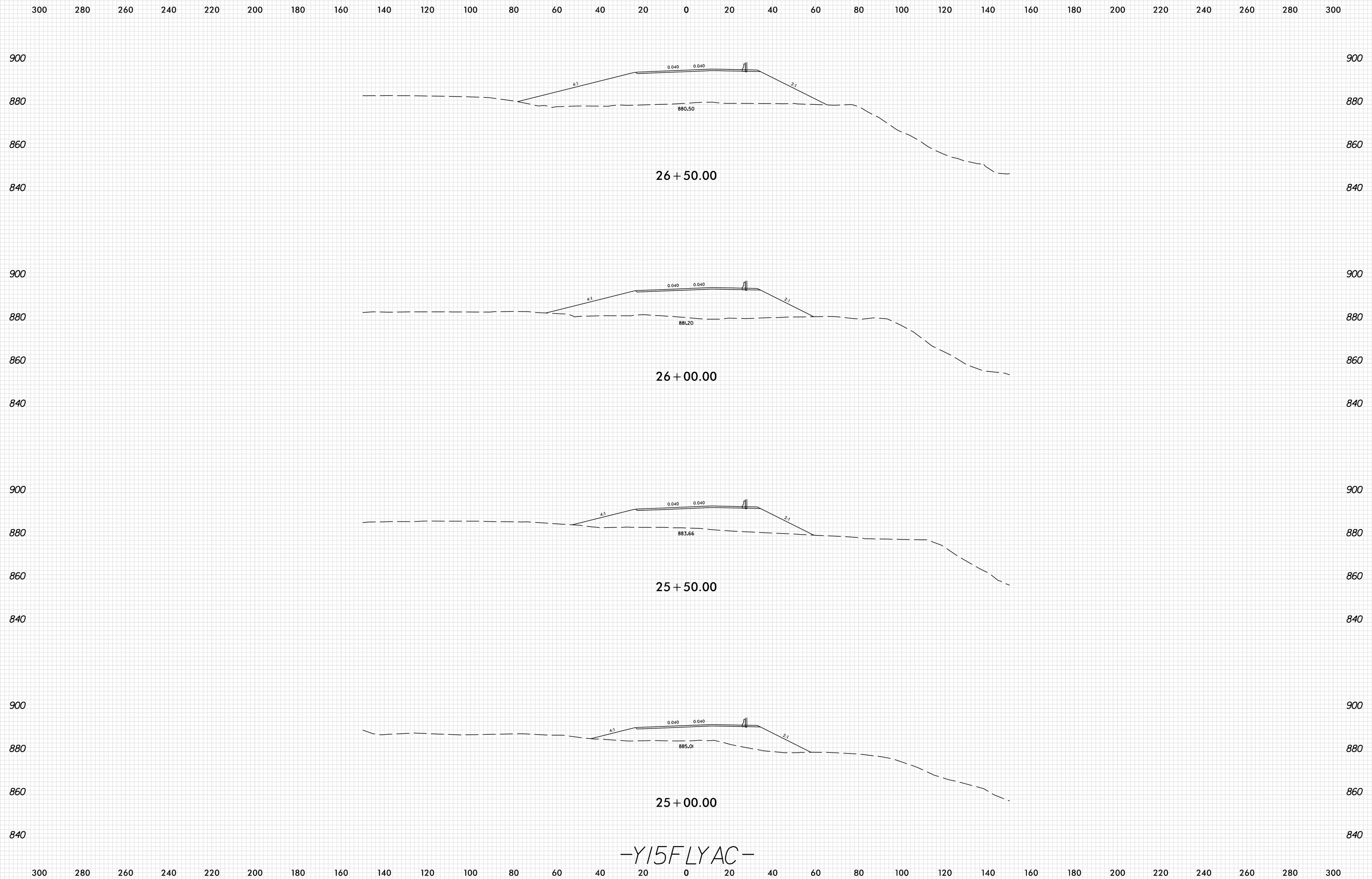

-Y15FLYAC-

PLOT DRIVER: NCD01_pdf_color_eng_100.plt
 USER: SPEREIRA
 DATE: 6/10/2021
 TIME: 2:25:47 PM
 FILE: \

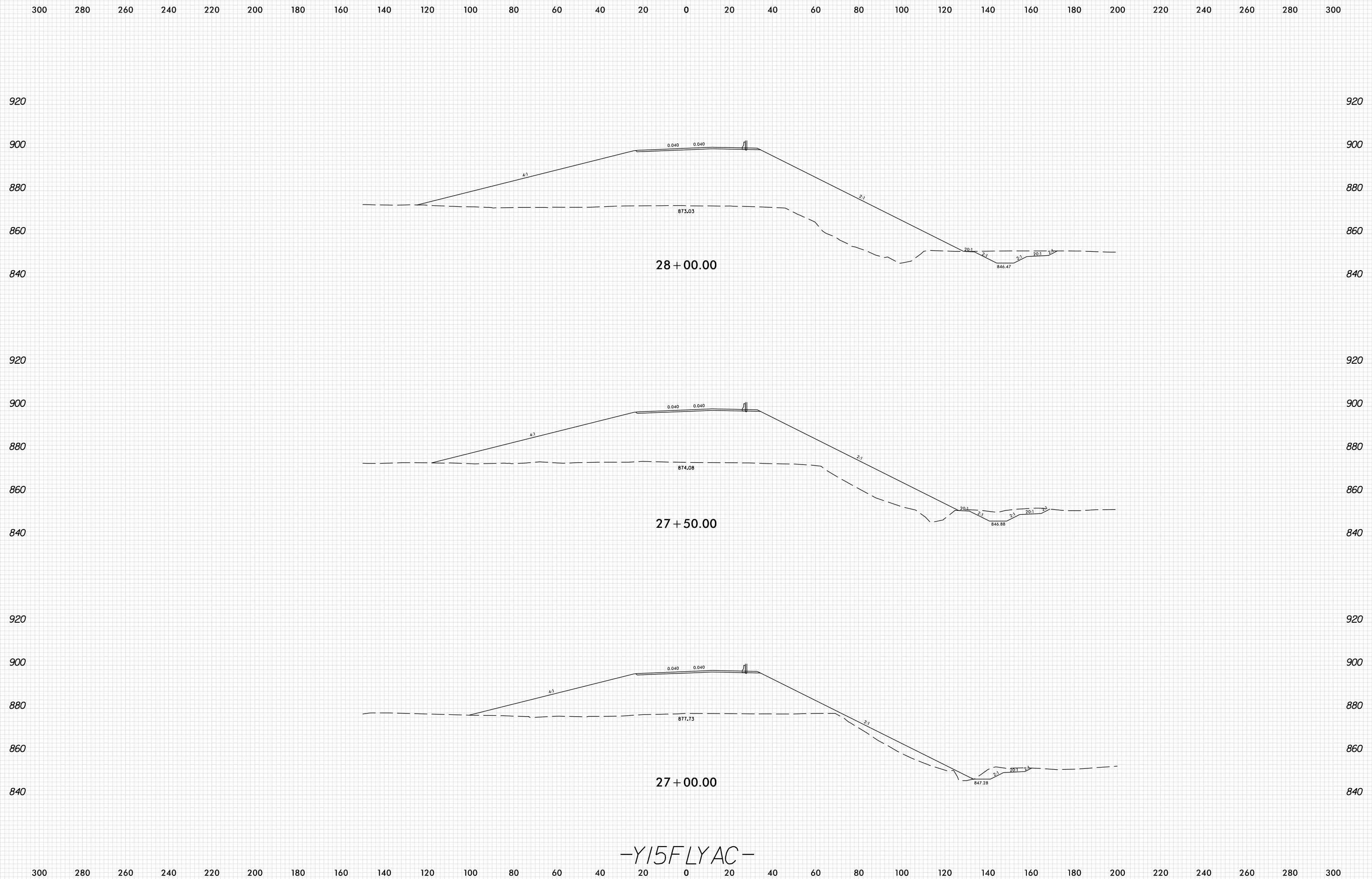

-Y15FLYAC-

8/23/99

0 10 20	PROJ. REFERENCE NO.	SHEET NO.
	U-2579AB	X-407

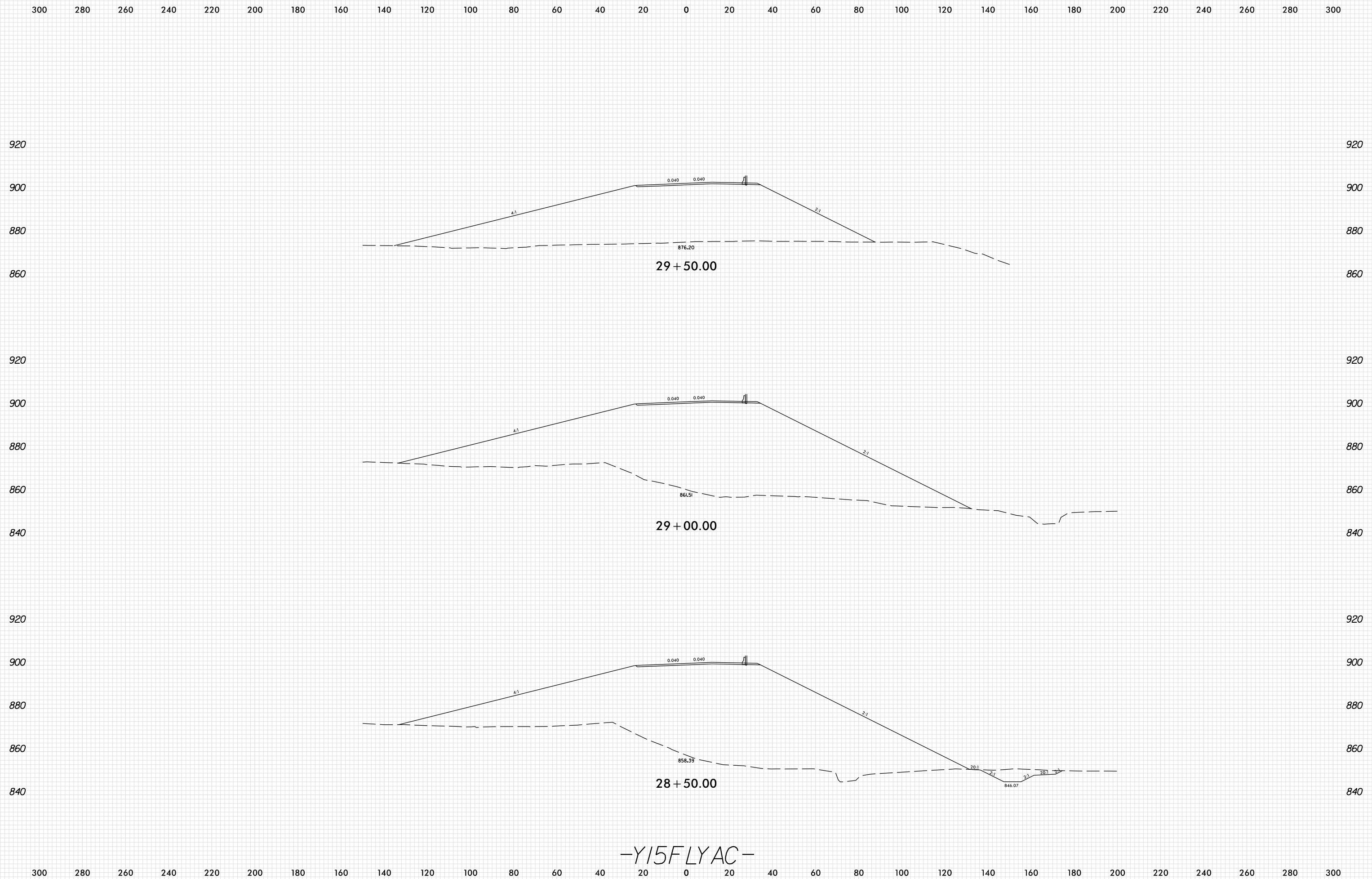

-Y15FLYAC-

PLOT DRIVER: NCDOT_pdf_color_eng_100.plt
 USER: SPEREIRA
 DATE: 6/10/2021
 TIME: 2:25:49 PM
 FILE: \

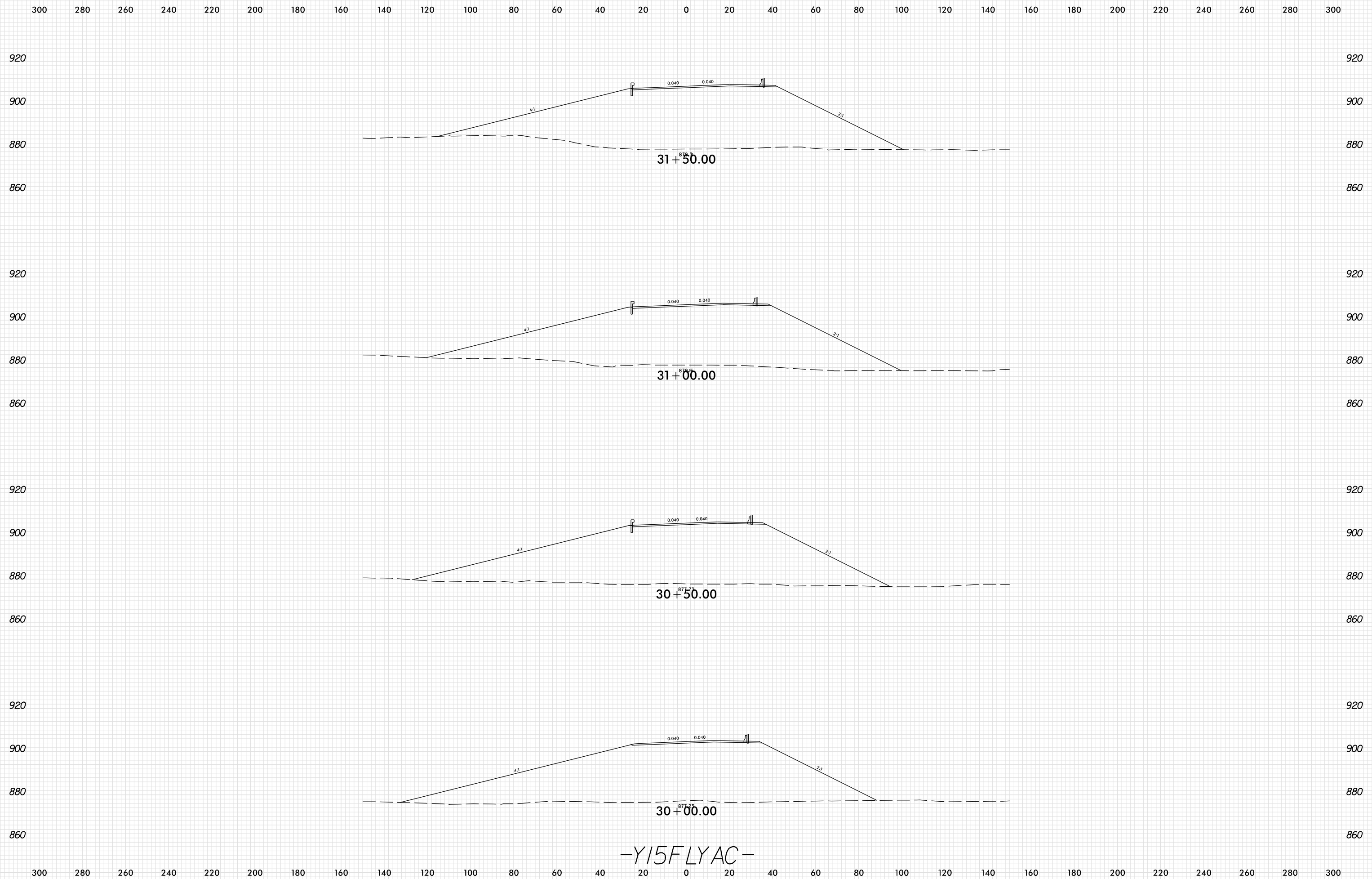

-Y15FLYAC-

8/23/99

0 10 20	PROJ. REFERENCE NO.	SHEET NO.
	U-2579AB	X-409

940 300 280 260 240 220 200 180 160 140 120 100 80 60 40 20 0 20 40 60 80 100 120 140 160 180 200 220 240 260 280 300 940

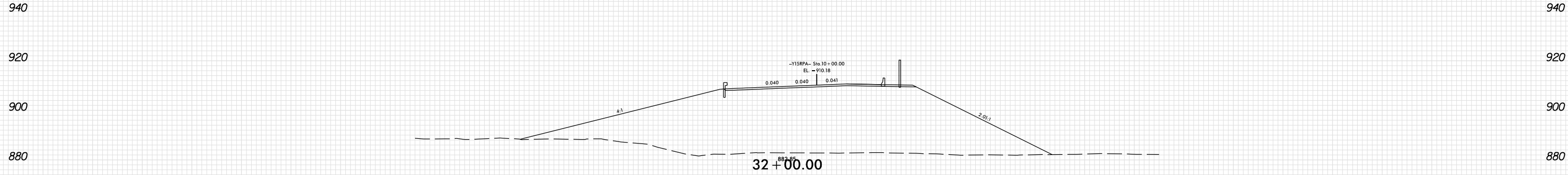
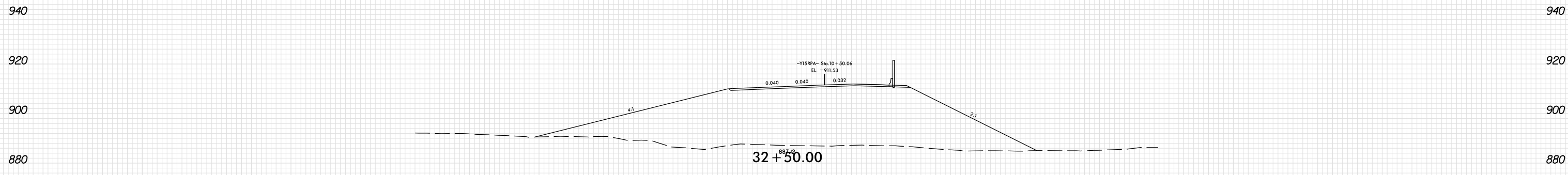
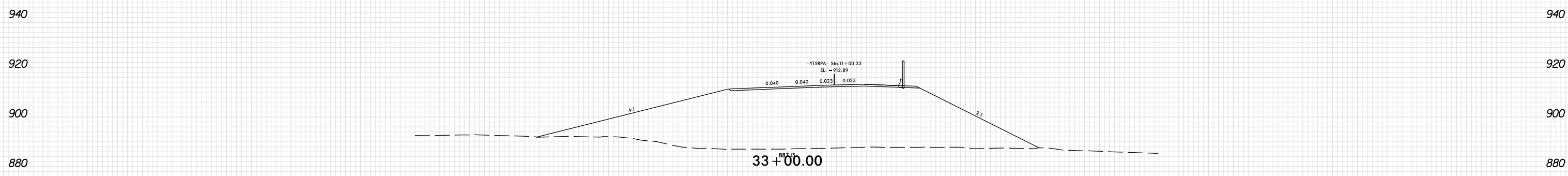
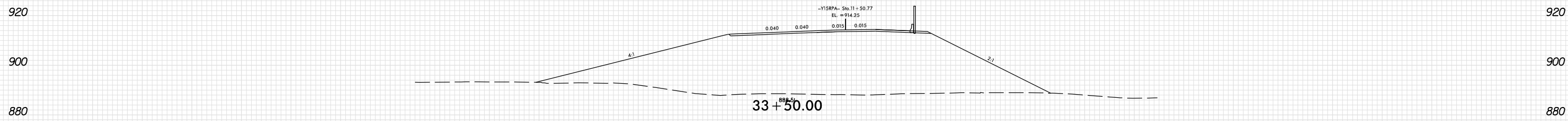

300 280 260 240 220 200 180 160 140 120 100 80 60 40 20 0 20 40 60 80 100 120 140 160 180 200 220 240 260 280 300

-Y15FLYAC-

PLOT DRIVER: NCD01_pdf_color_eng_100.plt
 USER: SPEREIRA
 DATE: 6/10/2021
 TIME: 2:25:51 PM
 FILE: \

8/23/99

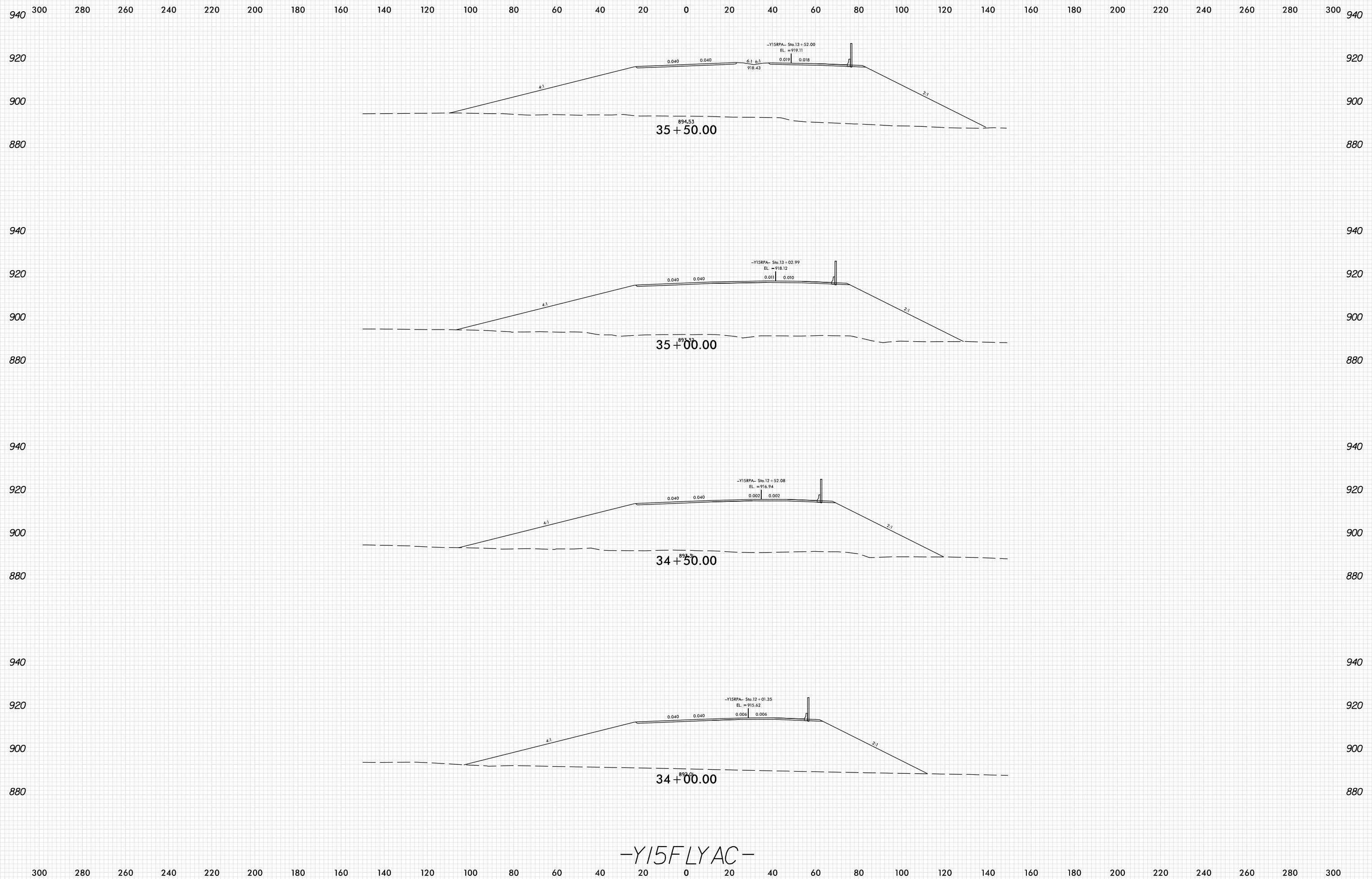

-Y15FLYAC-

PLOT DRIVER: NCD01_pdf_color_eng_100.plt
 USER: SPEREIRA
 DATE: 6/10/2021
 TIME: 2:25:52 PM
 FILE: \

8/23/99

0 10 20	PROJ. REFERENCE NO.	SHEET NO.
	U-2579AB	X-411

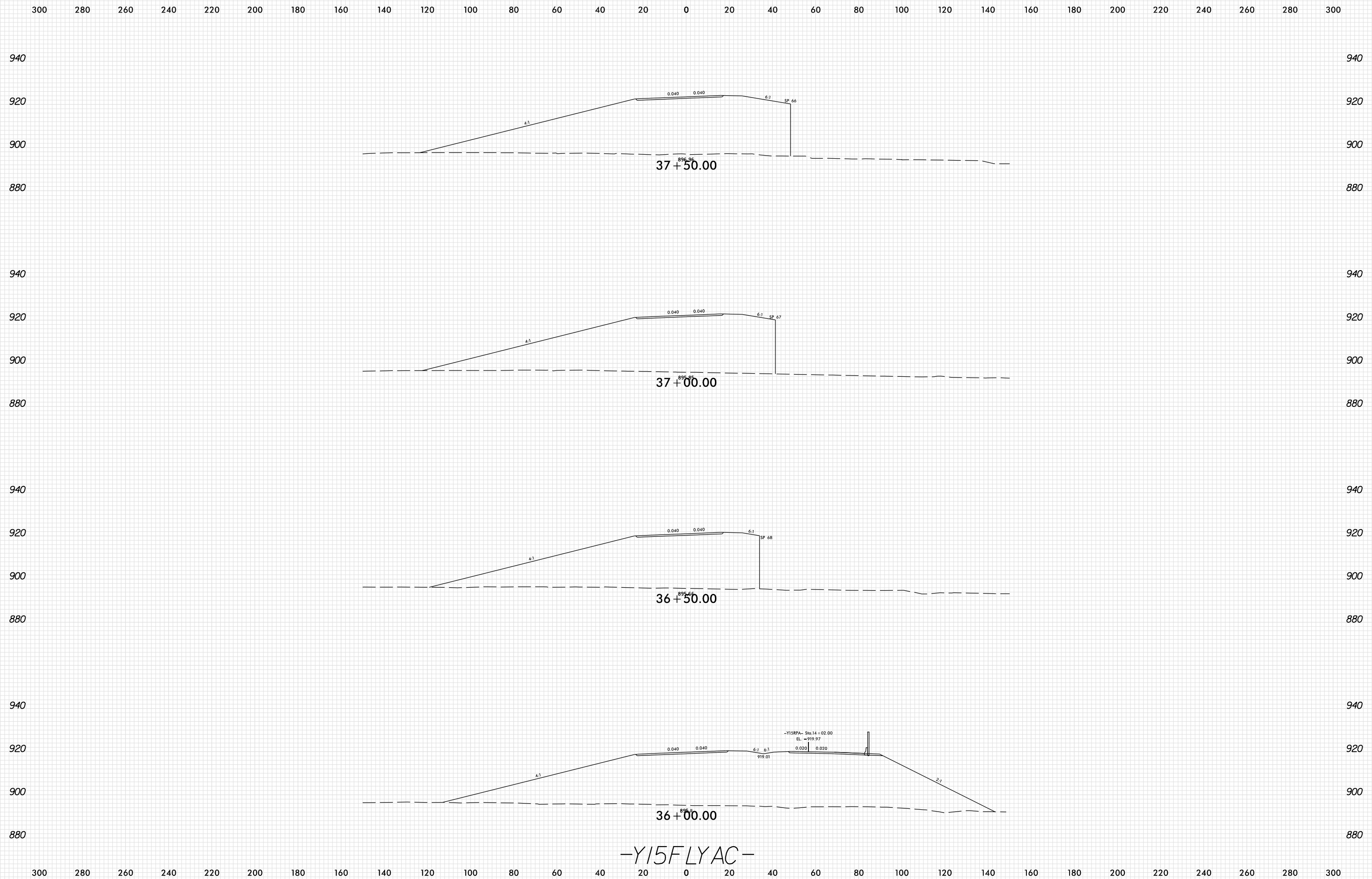

-Y15FLYAC-

PLOT DRIVER: NCD01_pdf_color_eng_100.plt
 USER: SPEREIRA
 DATE: 6/10/2021
 TIME: 2:25:53 PM
 FILE: \

8/23/99

0 10 20	PROJ. REFERENCE NO.	SHEET NO.
	U-2579AB	X-412

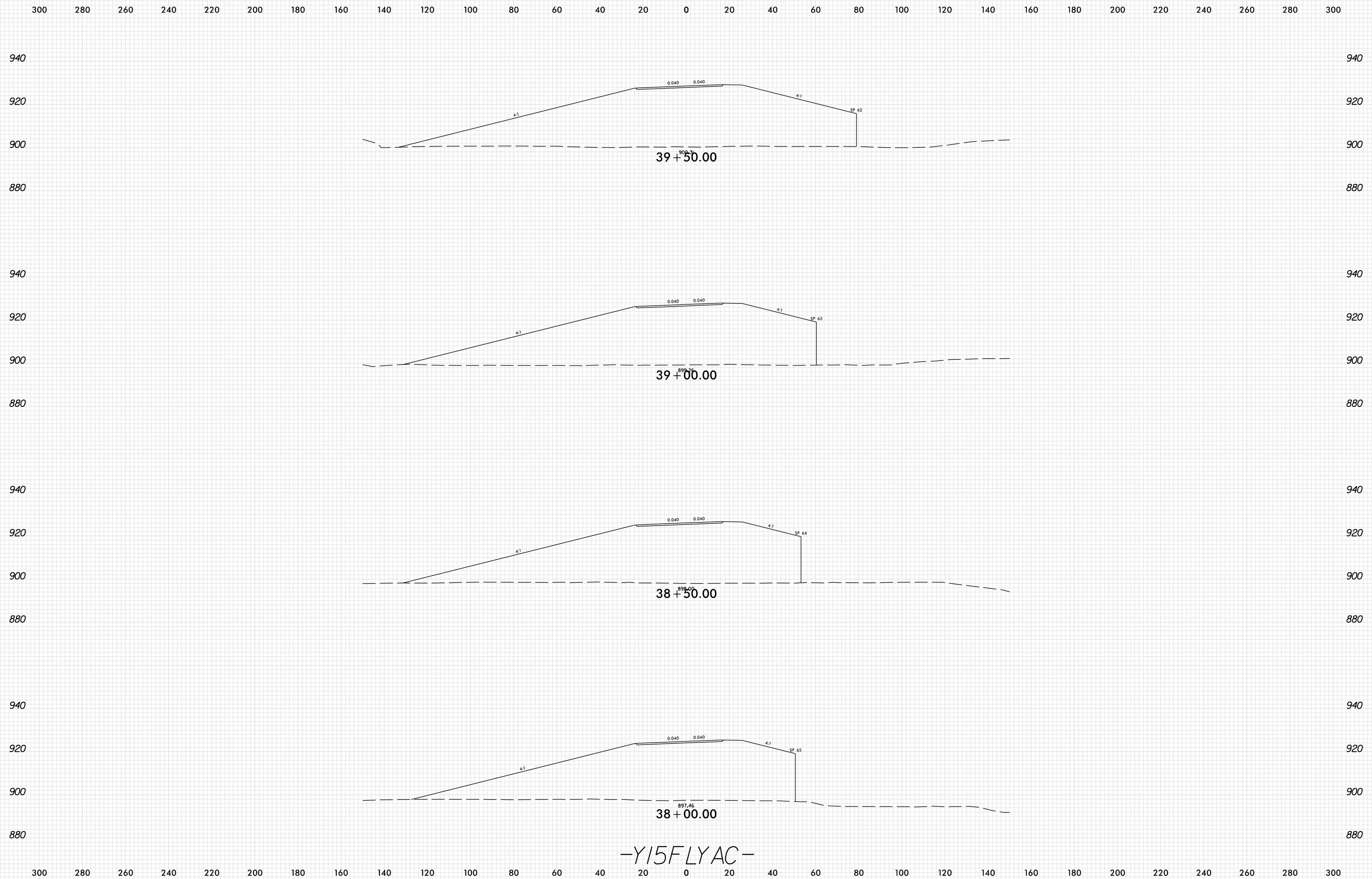

-Y15FLYAC-

PLOT DRIVER: NCD01_pdf_color_eng_100.plt
 USER: SPEREIRA
 DATE: 6/10/2021
 TIME: 2:25:53 PM
 FILE: \