

EDI MODEL 2018ECLIP-NC CONFLICT MONITOR PROGRAMMING DETAIL
(remove jumpers and set switches as shown)

REMOVE DIODE JUMPERS 1-5, 1-6, 2-5, 2-6, 3-7, 3-8, 3-10, 3-12, 4-7, 4-8, 4-10, 4-12, 7-10, 7-12, 8-10, 8-12, and 10-12.

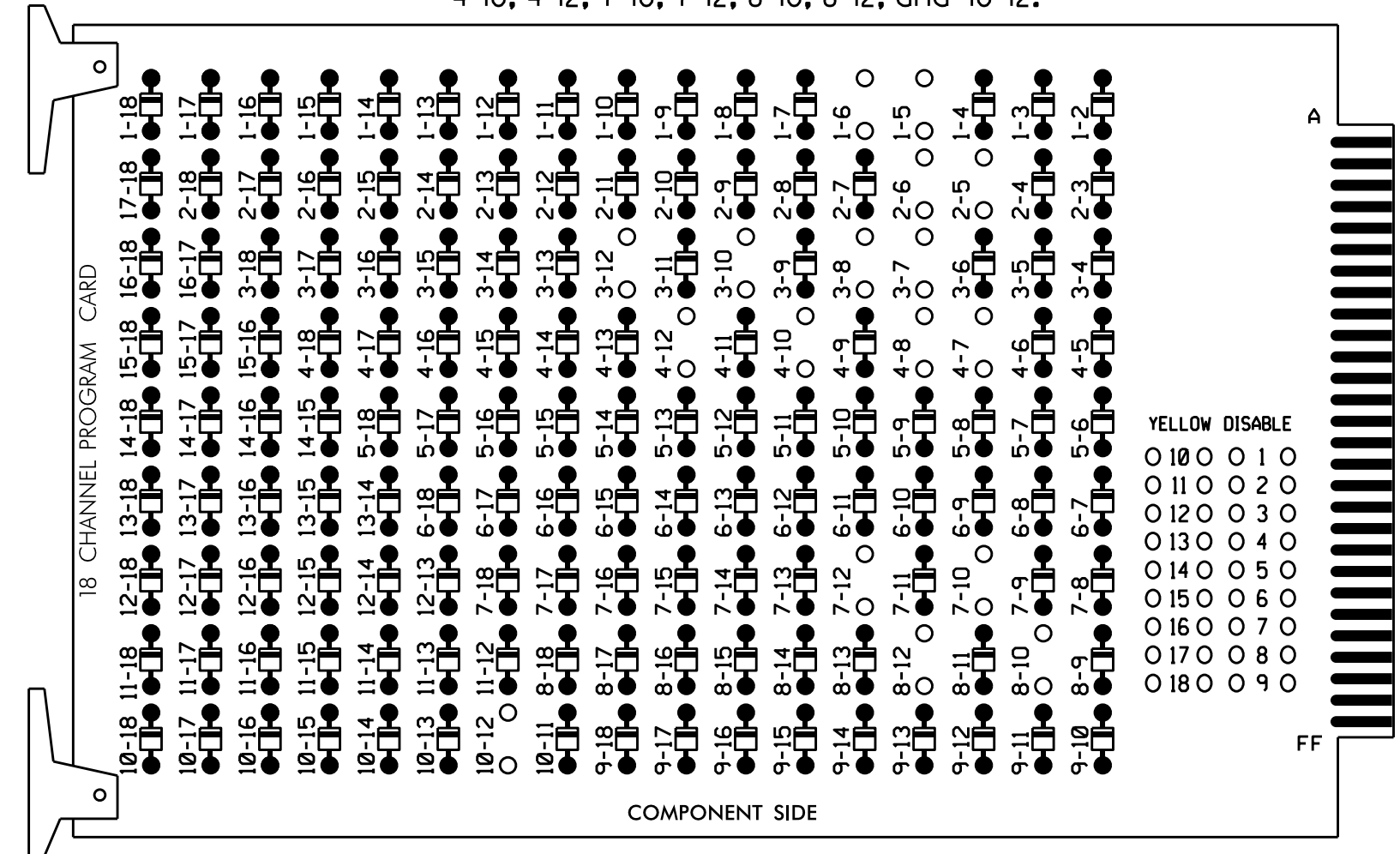

REMOVE JUMPERS AS SHOWN

- NOTES:
- Card is provided with all diode jumpers in place. Removal of any jumper allows its channels to run concurrently.
 - Ensure jumpers SEL2-SEL5 and SEL9 are present on the monitor board.
 - Ensure that Red Enable is active at all times during normal operation.
 - Integrate monitor with Ethernet network in cabinet.

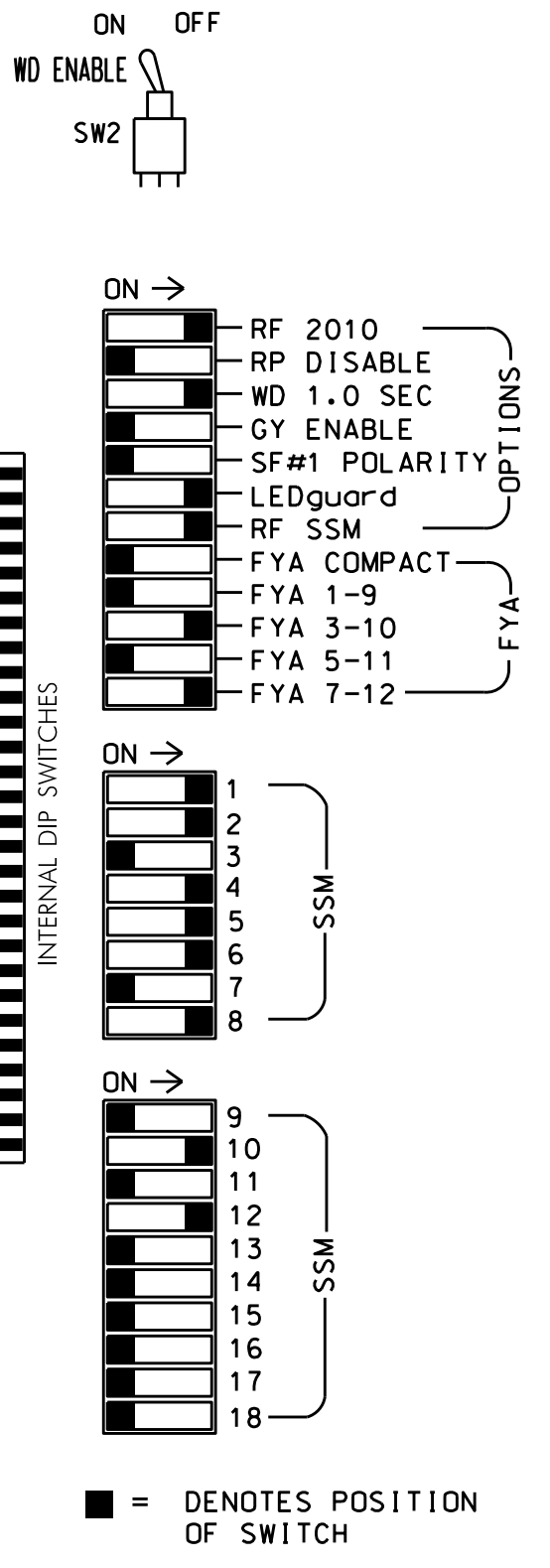

■ = DENOTES POSITION OF SWITCH

NOTES

- To prevent "flash-conflict" problems, insert red flash program blocks for all unused vehicle load switches in the output file. The installer shall verify that signal heads flash in accordance with the Signal Plans.
- Program phases 4 and 8 for Dual Entry.
- Enable Simultaneous Gap-Out for all Phases.
- Program phases 2 and 6 for Variable Initial and Gap Reduction.
- Program phases 2 and 6 for Startup In Green.
- Program phases 2 and 6 for Yellow Flash, and overlap 2 as Wag Overlaps.
- The cabinet and controller are part of the Winston-Salem Signal System.

EQUIPMENT INFORMATION

CONTROLLER.....2070
 CABINET.....332 W/ AUX
 SOFTWARE.....ECONOLITE OASIS
 CABINET MOUNT.....BASE
 OUTPUT FILE POSITIONS...18 WITH AUX. OUTPUT FILE
 LOAD SWITCHES USED.....S1,S2,S4,S5,S7,S8,S10,S11,
 AUX S2,AUX S5
 PHASES USED.....1,2,3,4,5,6,7,8
 OVERLAP "A".....NOT USED
 OVERLAP "B".....3+4
 OVERLAP "C".....NOT USED
 OVERLAP "D".....7+8

SIGNAL HEAD HOOK-UP CHART

LOAD SWITCH NO.	S1	S2	S3	S4	S5	S6	S7	S8	S9	S10	S11	S12	AUX S1	AUX S2	AUX S3	AUX S4	AUX S5	AUX S6
CMU CHANNEL NO.	1	2	13	3	4	14	5	6	15	7	8	16	9	10	17	11	12	18
PHASE	1	2	2 PED	3	4	4 PED	5	6	6 PED	7	8	8 PED	OLA	OLB	SPARE	OLC	OLD	SPARE
SIGNAL HEAD NO.	11	82	21,22	NU	31	41,42,43	NU	51	61,62	NU	71	81,82	NU	31	NU	NU	71	NU
RED		128			101			134			107							
YELLOW		129		*	102			135		*	108							
GREEN		130			103			136			109							
RED ARROW	125							131						A124				A101
YELLOW ARROW	126	126						132						A125				A102
FLASHING YELLOW ARROW														A126				A103
GREEN ARROW	127	127			118			133			124							

NU = Not Used
 * Denotes install load resistor. See load resistor installation detail this sheet.
 ★ See pictorial of head wiring in detail this sheet.

INPUT FILE POSITION LAYOUT

(front view)

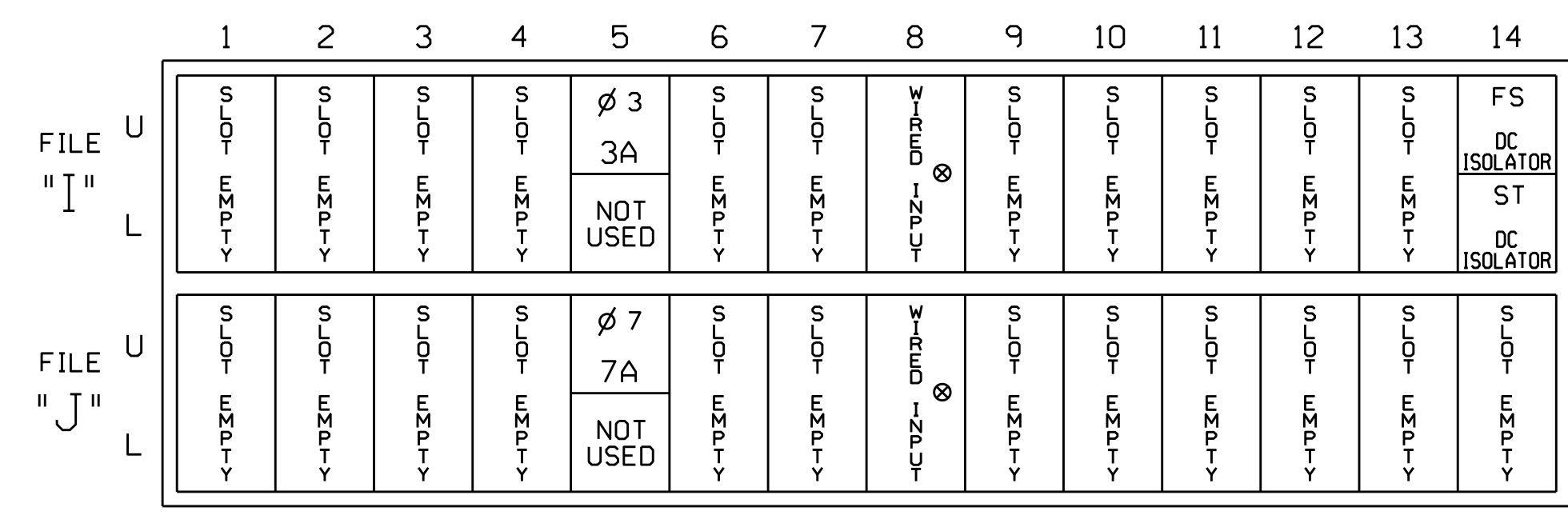

EX.: 1A, 2A, ETC. = LOOP NO.'S
 FS = FLASH SENSE
 ST = STOP TIME

INPUT FILE CONNECTION & PROGRAMMING CHART

LOOP NO.	LOOP TERMINAL	INPUT FILE POS.	PIN NO.	INPUT ASSIGNMENT NO.	DETECTOR NO.	NEMA PHASE	CALL	EXTEND	FULL TIME DELAY	STRETCH TIME	DELAY TIME
3A ¹	TB4-5,6	I5U	58	20	3	3	Y	Y			15
	-	J8U	50	12	28	8	Y	Y			3
7A ²	TB5-5,6	J5U	57	19	7	7	Y	Y			15
	-	I8U	49	11	24	4	Y	Y			3

- Add jumper from I5-W to J8-W, on rear of input file.
- Add jumper from J5-W to I8-W, on rear of input file.

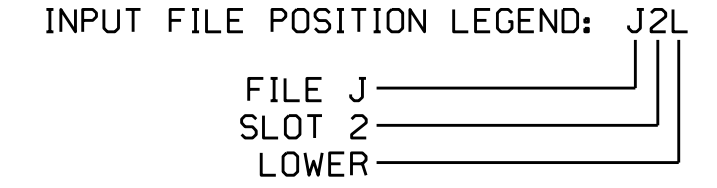

FYA SIGNAL WIRING DETAIL

(wire signal heads as shown)

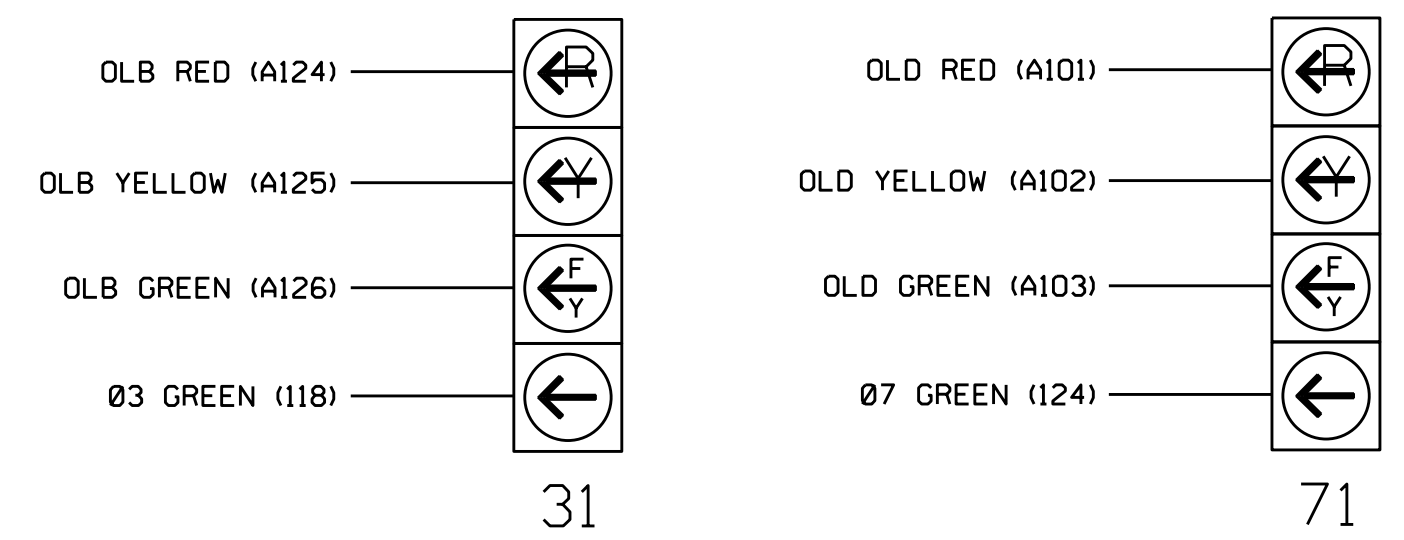

NOTE
 The sequence display for signal heads 31 and 71 requires special logic programming. See sheet 2 for programming instructions.

LOAD RESISTOR INSTALLATION DETAIL

(install resistors as shown below)

ACCEPTABLE VALUES

VALUE (ohms)	WATTAGE
1.5K - 1.9K	25W (min)
2.0K - 3.0K	10W (min)

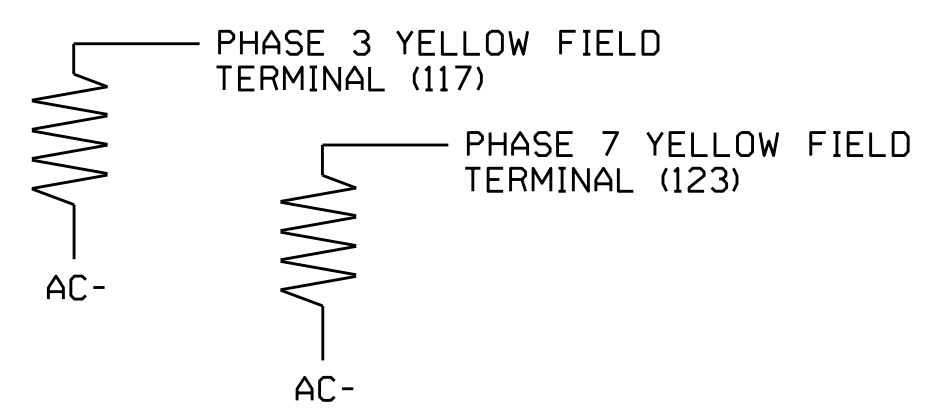

IMPORTANT! Remove resistor from phase 3 RED field terminal.

SPECIAL DETECTOR NOTE

Install a video detection system for vehicle detection. Perform installation according to manufacturer's directions and NCDOT engineer-approved mounting locations to accomplish the detection schemes shown on the Signal Design Plans.
 For Detection Zones 3A and 7A, the equipment placement and slots reserved for wired inputs are typical for a NCDOT installation.

Electrical Detail - Sheet 1 of 2
 Temporary Design 2 (TMP Area 3 Phase 2)

ELECTRICAL AND PROGRAMMING DETAILS FOR:
 Prepared in the Offices of:

 750 N. Greenfield Pkwy, Garner, NC 27529

SR 4315 (Kernersville Road) at Linville Rd./Motsinger Rd.

PLAN DATE: June 2021	REVIEWED BY:
PREPARED BY: S. Armstrong	REVIEWED BY:
REVISIONS	INIT. DATE

DOCUMENT NOT CONSIDERED FINAL UNLESS ALL SIGNATURES COMPLETED

SEAL
 NORTH CAROLINA PROFESSIONAL ENGINEER
 SEAL 036833
 RYAN W. HOUGH
 7/12/2021
 SIG. INVENTORY NO. 09-0660T2