

Project: R-5021

Contract: C204123

STATE OF NORTH CAROLINA
DIVISION OF HIGHWAYS
BRUNSWICK COUNTY

LOCATION: NC 211 FROM WEST OF NC 906 (MIDWAY ROAD / MIDDLETON BOULEVARD) TO EAST OF NC 87 /SR 1852
TYPE OF WORK: TRAFFIC SIGNALS, FIBER OPTIC CABLE, AND WIRELESS COMMUNICATION PLANS

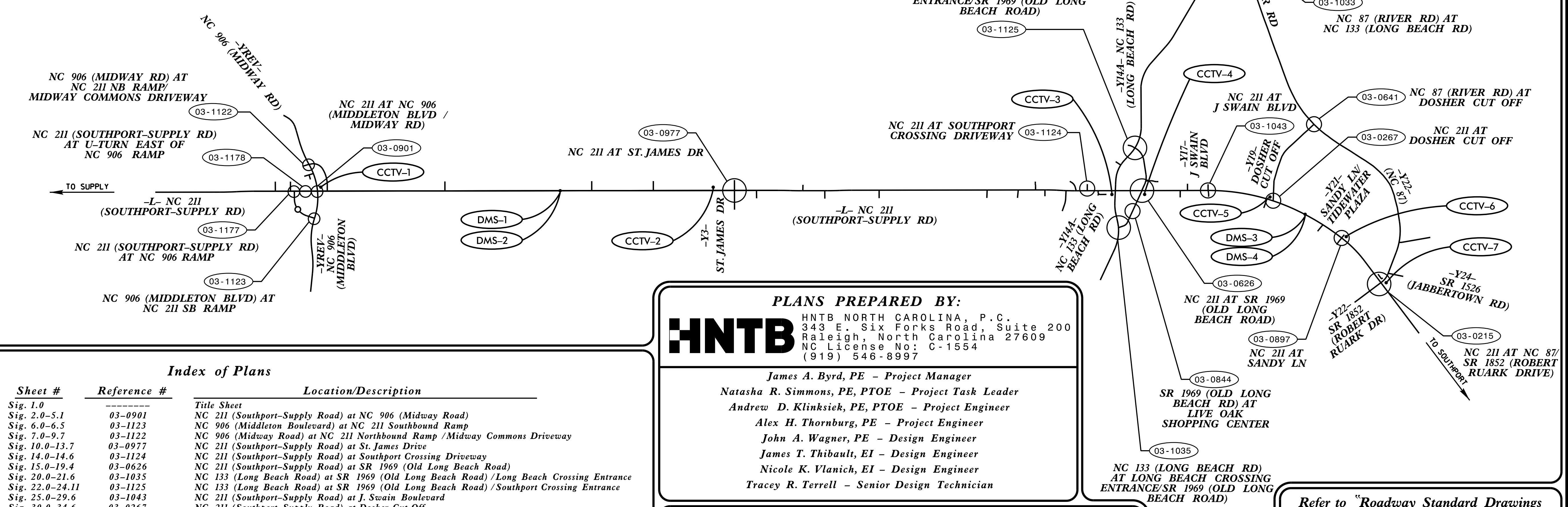
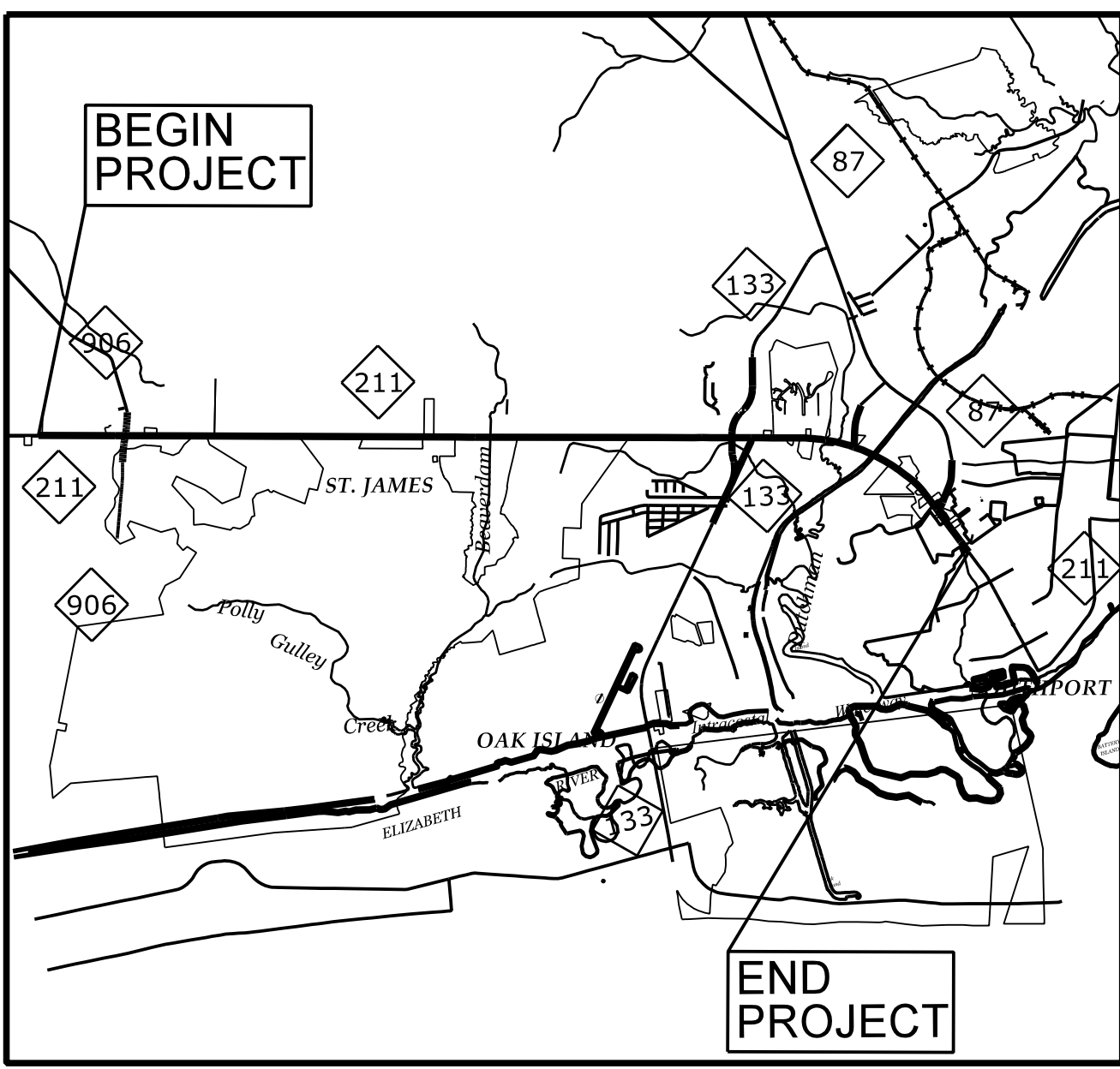

Index of Plans

Sheet #	Reference #	Location/Description
Sig. 1.0	-----	Title Sheet
Sig. 2.0-5.1	03-0901	NC 211 (Southport-Supply Road) at NC 906 (Midway Road)
Sig. 6.0-6.5	03-1123	NC 906 (Middleton Boulevard) at NC 211 Southbound Ramp
Sig. 7.0-9.7	03-1122	NC 906 (Midway Road) at NC 211 Northbound Ramp /Midway Commons Driveway
Sig. 10.0-13.7	03-0977	NC 211 (Southport-Supply Road) at St. James Drive
Sig. 14.0-14.6	03-1124	NC 211 (Southport-Supply Road) at Southport Crossing Driveway
Sig. 15.0-19.4	03-0626	NC 211 (Southport-Supply Road) at SR 1969 (Old Long Beach Road)
Sig. 20.0-21.6	03-1035	NC 133 (Long Beach Road) at SR 1969 (Old Long Beach Road) /Long Beach Crossing Entrance
Sig. 22.0-24.11	03-1125	NC 133 (Long Beach Road) at SR 1969 (Old Long Beach Road) /Southport Crossing Entrance
Sig. 25.0-29.6	03-1043	NC 211 (Southport-Supply Road) at J. Swain Boulevard
Sig. 30.0-34.6	03-0267	NC 211 (Southport-Supply Road) at Doshier Cut Off
Sig. 35.0-38.9	03-0897	NC 211 (Howe Street) at Tidewater Plaza /Sandy Lane
Sig. 39.0-45.11	03-0215	NC 211 (Howe Street) at NC 87 (River Road) /SR 1852 (Robert Ruark Drive)
Sig. 46.0-46.6	03-1177	NC 211 (Southport-Supply Road) at NC 906 (Midway Road) Ramp
Sig. 47.0-47.3	03-1178	NC 211 (Southport-Supply Road) at U-Turn East of NC 906 Ramp
Sig. 48.0	-----	Standard Drawings for Electrical Service Grounding and Wood Poles
Sig. 49.0	-----	Standard Drawings for Pedestals
Sig. M1-M8	-----	Standard Drawings for Metal Poles
SCP. 1-63	-----	Signal Communication Plans

PLANS PREPARED BY:
HNTB HNTB NORTH CAROLINA, P.C.
343 E. Six Forks Road, Suite 200
Raleigh, North Carolina 27609
NC License No: C-1554
(919) 546-8997

James A. Byrd, PE - Project Manager
Natasha R. Simmons, PE, PTOE - Project Task Leader
Andrew D. Klinksiek, PE, PTOE - Project Engineer
Alex H. Thornburg, PE - Project Engineer
John A. Wagner, PE - Design Engineer
James T. Thibault, EI - Design Engineer
Nicole K. Vlanich, EI - Design Engineer
Tracey R. Terrell - Senior Design Technician

LEGEND
##-#### SIGNAL INVENTORY NUMBER

INTELLIGENT TRANSPORTATION AND SIGNALS UNIT
Contacts:
Zachary Little, PE - Eastern Region Signals Engineer
Todd Joyce, PE - Signal Equipment Design Engineer
Heidi T. Berggren, EI - Signal Communications Project Engineer

NCDOT - DIVISION 3
Contacts:
Jessi Leonard, PE - Division Traffic Engineer
R. Coke Gray III, PE - Regional Traffic Engineer

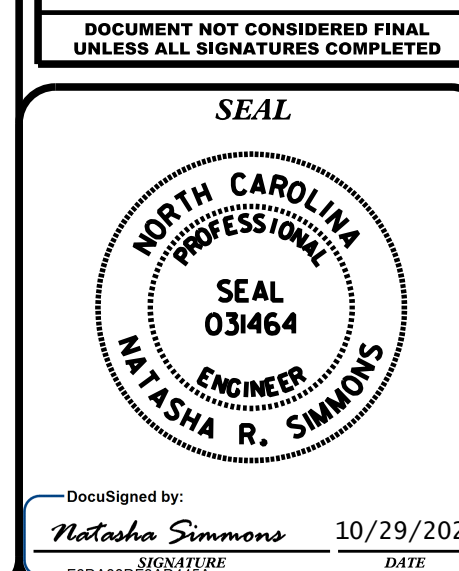

Refer to "Roadway Standard Drawings NCDOT" dated January 2018 and "Standard Specifications for Roads and Structures" dated January 2018.

Prepared for the Office of:
DIVISION OF HIGHWAYS
TRANSPORTATION MOBILITY AND SAFETY
DIVISION

750 N. Greenfield Parkway, Garner, NC 27529

SIGNAL FACE I.D.

All Heads L.E.D.

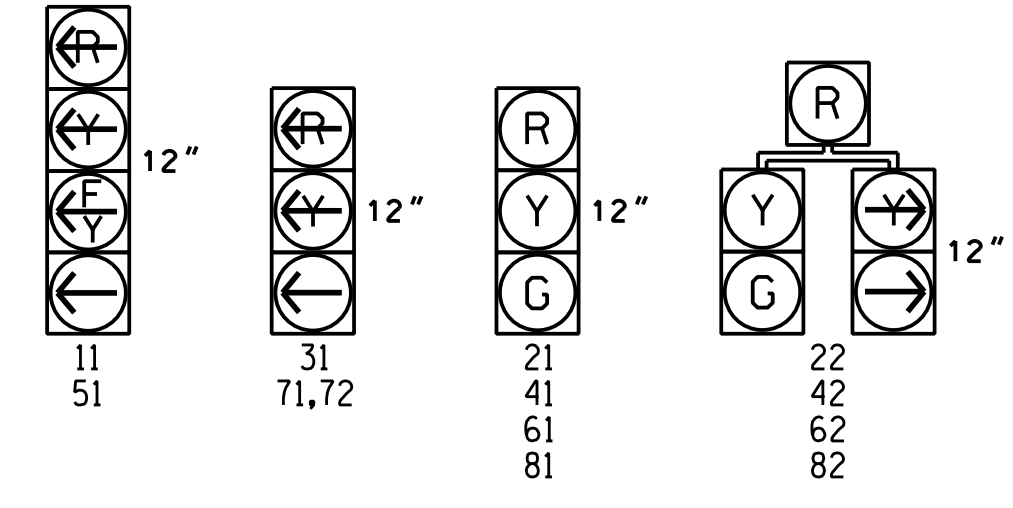

ALTERNATE PHASING DIAGRAM

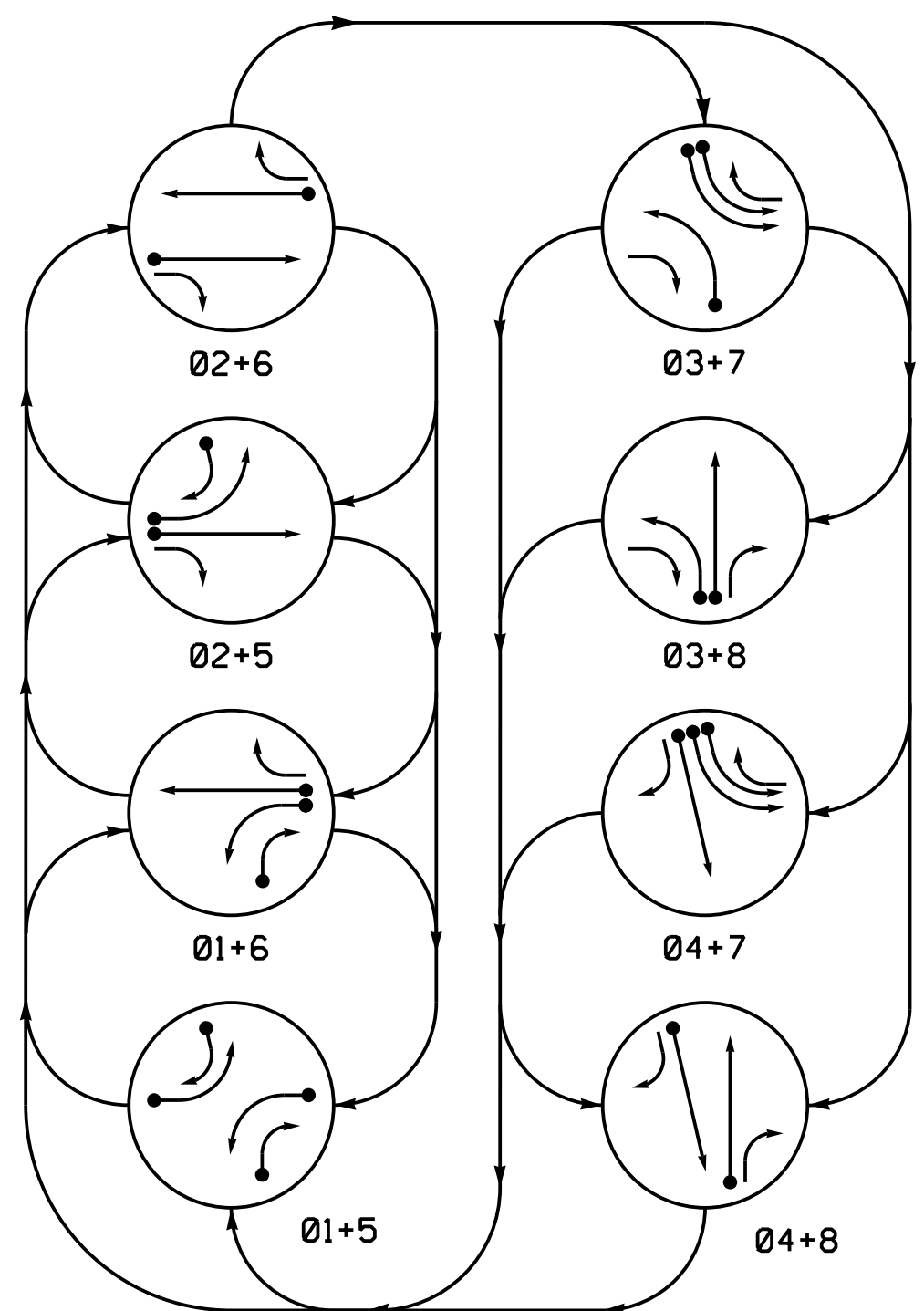

PHASING DIAGRAM DETECTION LEGEND

- ←●→ DETECTED MOVEMENT
- ←→ UNDETECTED MOVEMENT (OVERLAP)
- ←.....→ UNSIGNALIZED MOVEMENT
- ←- - - -> PEDESTRIAN MOVEMENT

ALTERNATE PHASING TABLE OF OPERATION

SIGNAL FACE	PHASE								FLIGHT
	01+5	01+6	02+5	02+6	03+7	03+8	04+7	04+8	
11	---	---	---	---	---	---	---	---	Y
21	R	R	G	G	R	R	R	R	Y
22	R	R	G	G	R	R	R	R	Y
31	---	---	---	---	---	---	---	---	---
41	R	R	R	R	R	R	G	G	R
42	R	R	R	R	R	R	G	G	R
51	---	---	---	---	---	---	---	---	Y
61	R	G	R	G	R	R	R	R	Y
62	R	G	R	G	R	R	R	R	Y
71,72	---	---	---	---	---	---	---	---	---
81	R	R	R	R	R	G	R	G	R
82	R	R	R	R	R	G	R	G	R

Signal Upgrade
 Temporary Design 1
 Construction Phase 1
 Sheet 2 of 2

**DOCUMENT NOT CONSIDERED FINAL
 UNLESS ALL SIGNATURES COMPLETED**

HNTB HNTB NORTH CAROLINA, P.C.
 343 E. Six Forks Road, Suite 200
 Raleigh, North Carolina 27609
 NC License No: C-1554
 (919) 546-8997

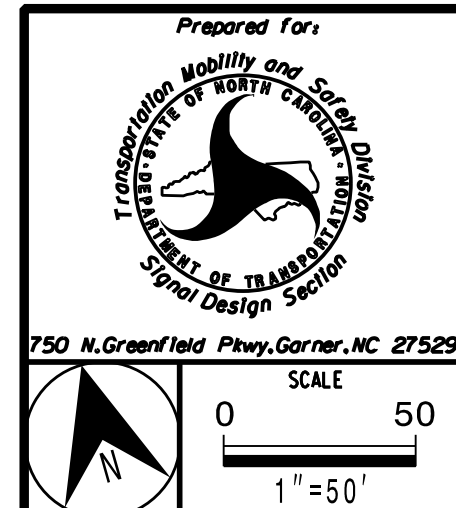

Prepared for:
 NC 211 (Southport-Supply Road)
 at
 NC 906 (Midway Road/
 Middleton Boulevard)
 Division 03 Brunswick Co. Southport
 PLAN DATE: June 2017 REVIEWED BY: A.D. Klinksiek
 PREPARED BY: A.H. Thornburg REVIEWED BY: N.R. Simmons

SEAL
 NORTH CAROLINA
 PROFESSIONAL
 SEAL
 031464
 ENGINEER
 NATASHA R. SIMMONS
 Signature: *Natasha Simmons*
 DATE: 9/10/2021
 SIG. INVENTORY NO. 03-090111

EDI MODEL 2018ECL-NC CONFLICT MONITOR PROGRAMMING DETAIL

(remove jumpers and set switches as shown)

REMOVE DIODE JUMPERS 1-5, 1-6, 1-9, 1-11, 2-5, 2-6, 2-9, 2-11, 3-7, 3-8, 4-7, 4-8, 5-9, 5-11, 6-9, 6-11 and 9-11.

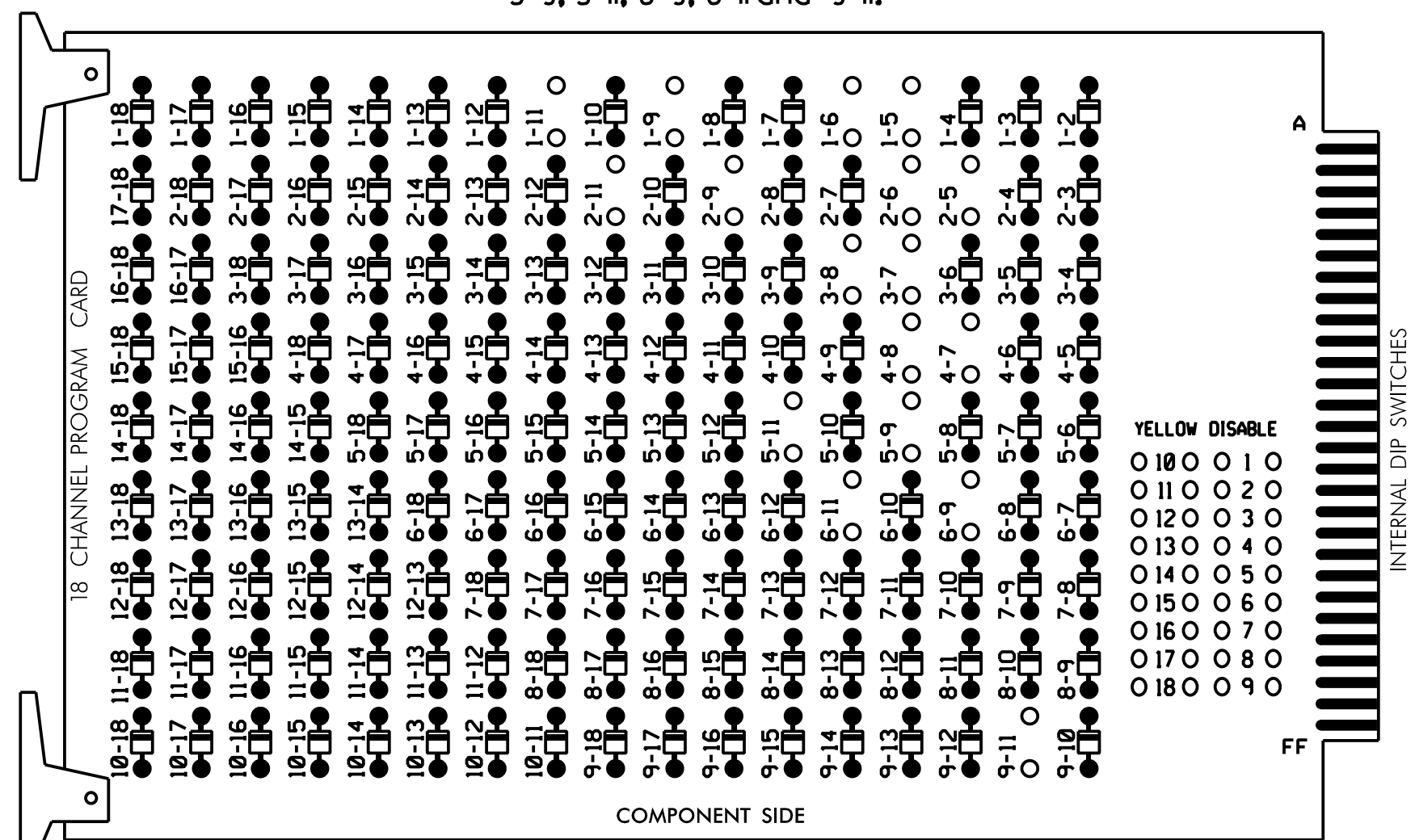

REMOVE JUMPERS AS SHOWN

NOTES:

- Card is provided with all diode jumpers in place. Removal of any jumper allows its channels to run concurrently.
- Ensure jumpers SEL2-SEL5 and SEL9 are present on the monitor board.
- Ensure that Red Enable is active at all times during normal operation.
- Connect serial cable from conflict monitor to comm. port 1 of 2070 controller. Ensure conflict monitor communicates with 2070.

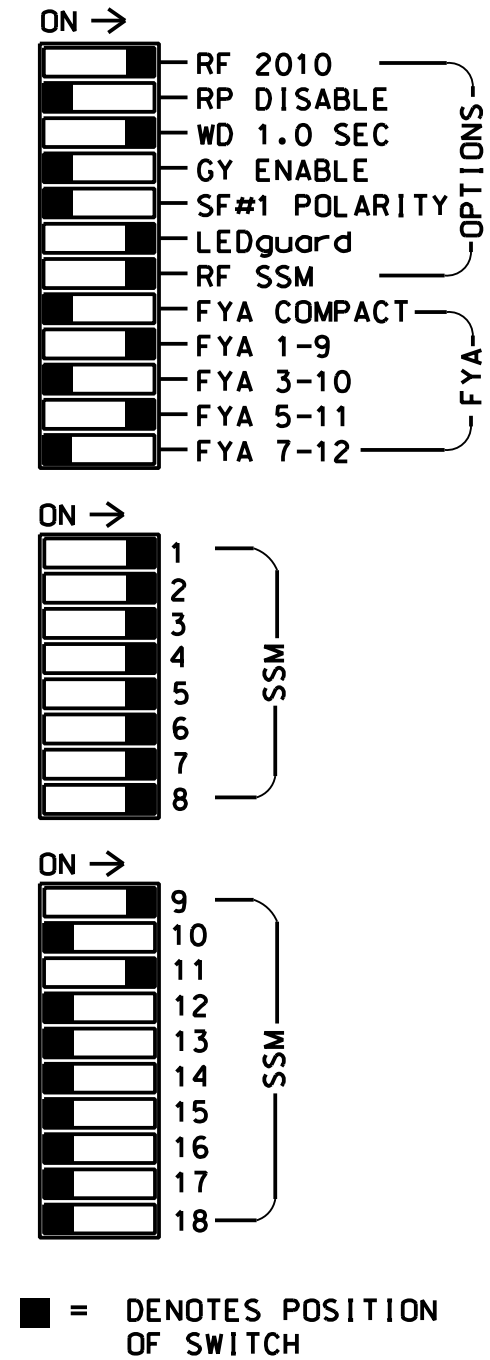
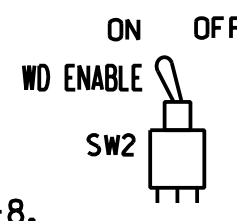

■ = DENOTES POSITION OF SWITCH

NOTES

- To prevent "flash-conflict" problems, insert red flash program blocks for all unused vehicle load switches in the output file. The installer shall verify that signal heads flash in accordance with the Signal Plans.
- Enable Simultaneous Gap-Out for all Phases.
- Program phases 2 and 6 for Variable Initial and phases 2,4,6, and 8 for Gap Reduction.
- Program phases 2 and 6 for Startup In Green.
- Program phases 2 and 6 for Yellow Flash, and overlap 1 as Wag Overlaps.
- If this signal will be managed by an ATMS software, enable controller and detector logging for all detectors used at this location.

EQUIPMENT INFORMATION

CONTROLLER.....2070E
 CABINET.....332 W/ AUX
 SOFTWARE.....ECONOLITE OASIS
 CABINET MOUNT.....BASE
 OUTPUT FILE POSITIONS...18 WITH AUX. OUTPUT FILE
 LOAD SWITCHES USED.....S1,S2,S4,S5,S7,S8,S10,S11
 AUX S1,AUX S4
 PHASES USED.....1,2,3,4,5,6,7,8
 OVERLAP "A".....1+2
 OVERLAP "B".....NOT USED
 OVERLAP "C".....5+6
 OVERLAP "D".....NOT USED

SIGNAL HEAD HOOK-UP CHART

LOAD SWITCH NO.	S1	S2	S3	S4	S5	S6	S7	S8	S9	S10	S11	S12	AUX S1	AUX S2	AUX S3	AUX S4	AUX S5	AUX S6		
CMU CHANNEL NO.	1	2	13	3	4	14	5	6	15	7	8	16	9	10	17	11	12	18		
PHASE	1	2	2 PED	3	4	4 PED	5	6	6 PED	7	8	8 PED	OLA	OLB	SPARE	OLC	OLD	SPARE		
SIGNAL HEAD NO.	11	82	21,22	NU	22	31	41,42	NU	42	51	61,62	NU	62	71,72	81,82	NU	11	NU	51	NU
RED		*	128			101		*		134			107							
YELLOW			129			102				135			108							
GREEN			130			103				136			109							
RED ARROW					116						122		A121					A114		
YELLOW ARROW		126			117	117			132		123	123		A122				A115		
FLASHING YELLOW ARROW														A123				A116		
GREEN ARROW	127	127			118	118			133	133		124	124							

NU = Not Used

* Denotes install load resistor. See load resistor installation detail this sheet.

★ See pictorial of head wiring in detail this sheet.

INPUT FILE POSITION LAYOUT

(front view)

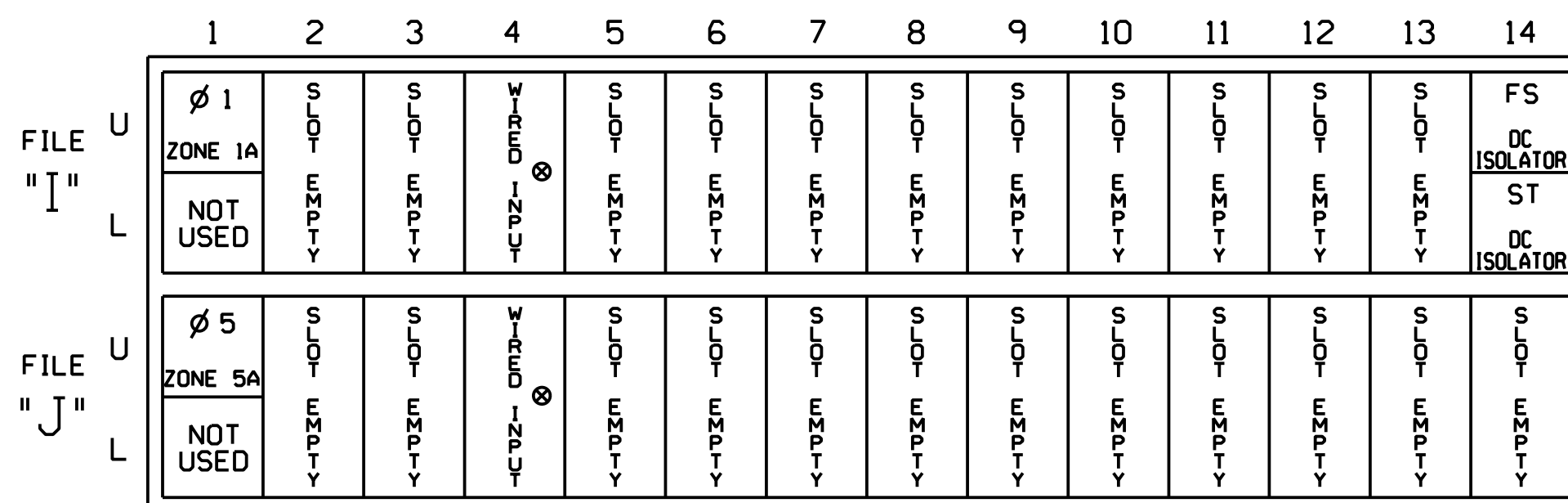

EX.: 1A, 2A, ETC. = LOOP NO.'S

FS = FLASH SENSE
 ST = STOP TIME

⊗ Wired Input - Do not populate slot with detector card

INPUT FILE CONNECTION & PROGRAMMING CHART

LOOP NO.	LOOP TERMINAL	INPUT FILE POS.	PIN NO.	INPUT ASSIGNMENT NO.	DETECTOR NO.	NEMA PHASE	CALL	EXTEND	FULL TIME DELAY	STRETCH TIME	DELAY TIME
ZONE 1A ¹	**	I1U	56	18	1	1	Y	Y			15
	-	J4U	48	10★	26	6	Y	Y	Y		3
	-	I1U	56	18★	51	1	Y	Y			3
ZONE 5A ²	**	J1U	55	17	5	5	Y	Y			15
	-	I4U	47	9★	22	2	Y	Y	Y		3
		J1U	55	17★	55	5	Y	Y			3

- Add jumper from I1-W to J4-W, on rear of input file.
 - Add jumper from J1-W to I4-W, on rear of input file.
- * See Input Page Assignment programming details on sheets 3 and 4.
 ** Multizone Microwave Detector Zone. See Special Detector Note.

INPUT FILE POSITION LEGEND: J2L

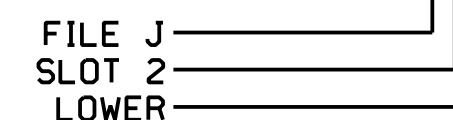

SPECIAL DETECTOR NOTE

Install a microwave detection system for vehicle detection. Perform installation according to manufacturer's directions and NCDOT engineer-approved mounting locations to accomplish the detection schemes shown on the Signal Design Plans.

For loops 1A and 5A detector card placement and slots reserved for wired inputs are typical for a NCDOT installation. Inputs associated with these slots are compatible with the time of day instructions located on sheets 3, 4, and 5 of this electrical detail.

FYA SIGNAL WIRING DETAIL

(wire signal heads as shown)

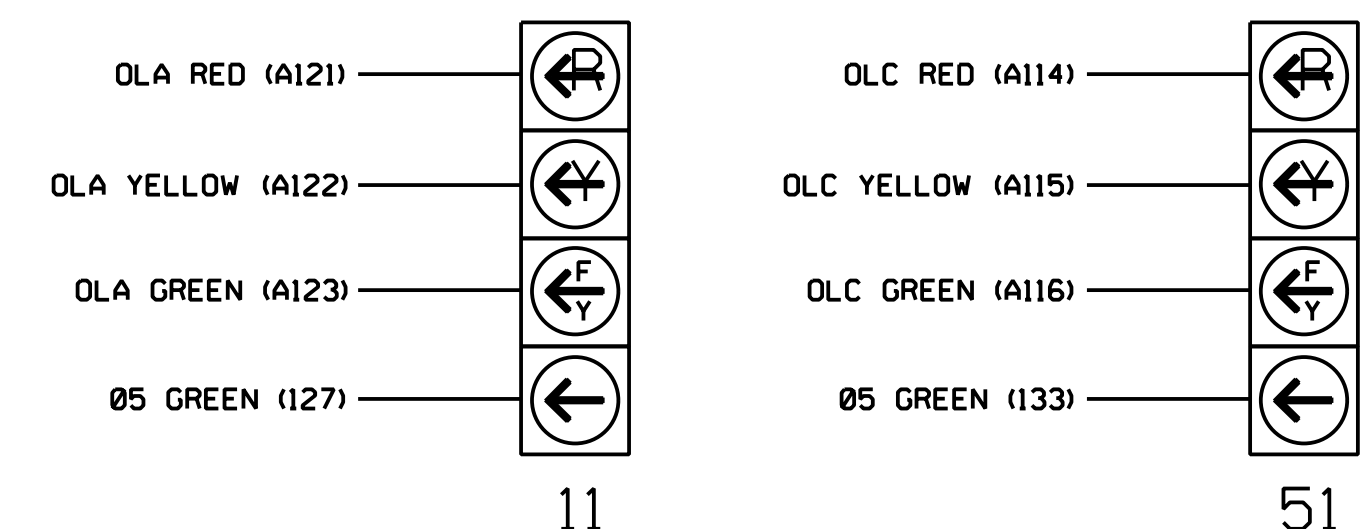

NOTE

The sequence display for signal heads 11 and 51 requires special logic programming. See sheet 2 for programming instructions.

LOAD RESISTOR INSTALLATION DETAIL

(install resistors as shown)

VALUE (ohms)	WATTAGE
1.5K - 1.9K	25W (min)
2.0K - 3.0K	10W (min)

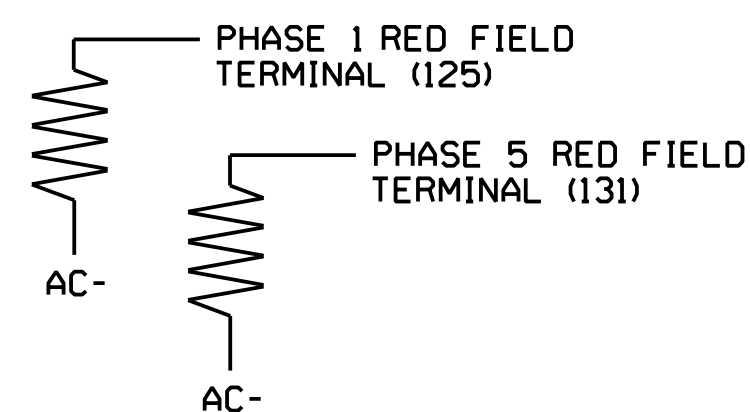

Electrical Detail - Sheet 1 of 5
 Signal Upgrade
 Temporary Design 1

DOCUMENT NOT CONSIDERED FINAL UNLESS ALL SIGNATURES COMPLETED

	Prepared for: NC 211 (Southport-Supply Road)		SEAL
	at NC 906 (Midway Road/ Middleton Boulevard)		
Division 03 Brunswick Co. Southport		PLAN DATE: June 2017 REVIEWED BY: A.D. Klinksiek	
PREPARED BY: A.H. Thornburg REVIEWED BY: N.R. Simmons		REVISIONS: INIT. DATE	
HNTB NORTH CAROLINA, P.C. 343 E. Six Forks Road, Suite 200 Raleigh, North Carolina 27609 NC License No: C-1564 (919) 546-8997		Prepared by: Natasha Simmons 9/10/2021 SIGNATURE DATE SIG. INVENTORY NO. 03-090111	

LOGICAL I/O PROCESSOR PROGRAMMING DETAIL TO PRODUCE SPECIAL FYA-PPLT SIGNAL SEQUENCE

(program controller as shown below)

- 1. FROM MAIN MENU PRESS '2' (PHASE CONTROL), THEN '1' (PHASE CONTROL FUNCTIONS)... 2. FROM MAIN MENU PRESS '6' (OUTPUTS), THEN '3' (LOGICAL I/O PROCESSOR).

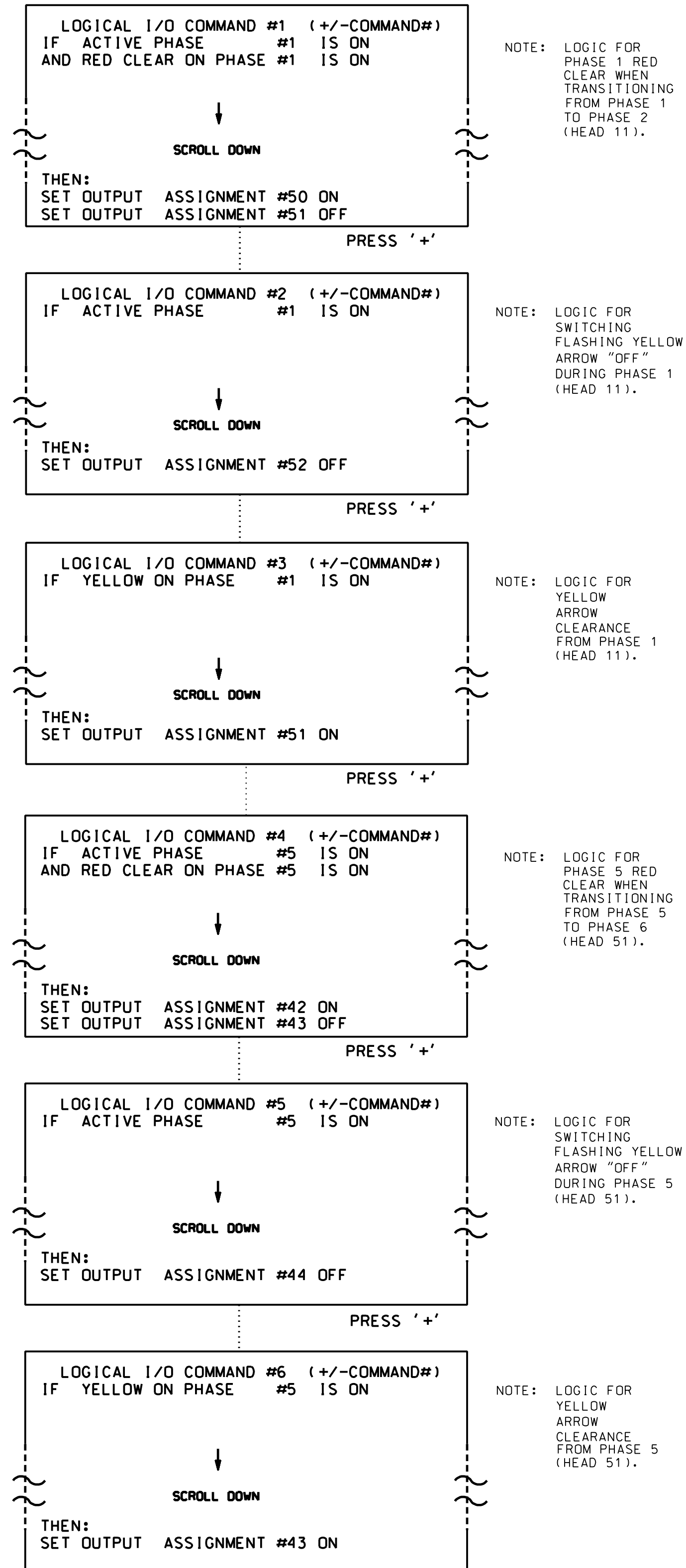

LOGIC I/O PROCESSOR PROGRAMMING COMPLETE

OVERLAP PROGRAMMING DETAIL FOR DEFAULT PHASING

(program controller as shown below)

FROM MAIN MENU PRESS '8' (OVERLAPS), THEN '1' (VEHICLE OVERLAP SETTINGS).

PAGE 1: VEHICLE OVERLAP 'A' SETTINGS PHASE: 12345678910111213141516...

NOTICE GREEN FLASH

PRESS '+' TWICE

PAGE 1: VEHICLE OVERLAP 'C' SETTINGS PHASE: 12345678910111213141516...

NOTICE GREEN FLASH

OVERLAP PROGRAMMING COMPLETE

OVERLAP PROGRAMMING DETAIL FOR ALTERNATE PHASING

(program controller as shown below)

FROM MAIN MENU PRESS '8' (OVERLAPS), THEN '1' (VEHICLE OVERLAP SETTINGS), PRESS 'NEXT' TO ADVANCE TO PAGE 2.

NOTICE PAGE 2

PAGE 2: VEHICLE OVERLAP 'A' SETTINGS PHASE: 12345678910111213141516...

PRESS '+' TWICE

NOTICE PAGE 2

PAGE 2: VEHICLE OVERLAP 'C' SETTINGS PHASE: 12345678910111213141516...

OVERLAP PROGRAMMING COMPLETE

OUTPUT REFERENCE SCHEDULE

USE TO INTERPRET LOGIC PROCESSOR

- OUTPUT 42 = Overlap C Red OUTPUT 43 = Overlap C Yellow OUTPUT 44 = Overlap C Green OUTPUT 50 = Overlap A Red OUTPUT 51 = Overlap A Yellow OUTPUT 52 = Overlap A Green

THIS ELECTRICAL DETAIL IS FOR THE SIGNAL DESIGN: 03-0901T1 DESIGNED: June 2017 SEALED: 9/10/2021 REVISED: N/A

Electrical Detail - Sheet 2 of 5 Signal Upgrade Temporary Design 1

DOCUMENT NOT CONSIDERED FINAL UNLESS ALL SIGNATURES COMPLETED

Professional Engineer seal for Natasha R. Simmons, North Carolina License No. 031464. Includes project details for NC 211 (Southport-Supply Road) at NC 906 (Midway Road/Middleton Boulevard).

INPUT PAGE 2 ASSIGNMENT PROGRAMMING DETAIL FOR ALTERNATE PHASING - LOOP 1A

(program controller as shown below)

- NOTES: 1. THIS PROGRAMMING APPLIES FOR INPUT PAGE 2 ONLY. INPUT PAGE 1 WILL USE STANDARD DEFAULT SETTINGS. THIS PROGRAMMING IS NECESSARY FOR PROPER DETECTOR OPERATION DURING ALTERNATE PHASING OPERATION. 2. THE FIRST TASK THIS PROGRAMMING ACCOMPLISHES IS THE DISABLING OF INPUT #10 (DETECTOR 26) SO THAT A VEHICLE CALL WILL NOT BE PLACED TO PHASE 6 DURING ALTERNATE PHASING OPERATION. THE SECOND TASK THIS PROGRAMMING ACCOMPLISHES IS THAT IT REASSIGNS DETECTOR 51 TO INPUT #18 SO THAT THE DELAY ON LOOP 1A CAN BE REDUCED FROM 15 SECONDS TO 3 SECONDS.

FROM MAIN MENU PRESS '5' (INPUTS). THEN PRESS 'NEXT' TO GET TO INPUT PAGE '2'. PRESS THE '+' KEY UNTIL INPUT 10 IS REACHED.

PAGE: 2 C1 PIN:48 VEHICLE DETECTOR INPUT ASSIGNMENT #.....10 DEBOUNCE TIME (0-25.5 SEC).....0.5 DELAY TIME (0-25.5 SEC).....0.0 HOLD-OVER TIME (0-25.5 SEC).....0.0 ASSIGNMENT SELECTION: NOT ENABLED (Y/N).....Y VEHICLE DETECTOR (1-64).....26 PEDESTRIAN DETECTOR (1-16)..... ALTERNATE PED DETECTOR (1-16)..... PREEMPT (1-10)..... INVERTED PREEMPT (1-10)..... STOP TIME (Y/N)..... FLASH SENSE (Y/N)..... DOOR OPEN (Y/N)..... MANUAL CONTROL ENABLE (Y/N)..... MANUAL CONTROL ADVANCE (Y/N)..... SPECIAL FUNCTION ALARM (1-8)..... TOD HOUR SYNCHRONIZATION (0-23)..... FORCE OFF RING (1-4)..... HOLD PHASES (1-16)..... PLAN (65=FLSH,66=FREE)... OFFSET#... CHANGE PHASE SEQUENCE PAGE (1-12)... CHANGE PHASE TIMING PAGE (1-4)... CHANGE PHASE CONTROL PAGE (1-4)... CHANGE OVERLAP CONTROL PAGE (1-4)... CHANGE INPUT PAGE (1-4)... CHANGE OUTPUT PAGE (1-4)... OVERRIDE PHASE CONTROL FUNCTION (Y)...

ENTER A 'Y' FOR NOT ENABLED
DEFAULT DETECTOR NUMBER WILL REMAIN UNTIL "NOT ENABLED" IS ENTERED.

(LOOP 1A - PHASE 6)

PAGE: 2 C1 PIN:48 NOT ENABLED INPUT ASSIGNMENT #.....10 DEBOUNCE TIME (0-25.5 SEC).....0.5 DELAY TIME (0-25.5 SEC).....0.0 HOLD-OVER TIME (0-25.5 SEC).....0.0 ASSIGNMENT SELECTION: NOT ENABLED (Y/N).....Y VEHICLE DETECTOR (1-64)..... PEDESTRIAN DETECTOR (1-16)..... ALTERNATE PED DETECTOR (1-16)..... PREEMPT (1-10)..... INVERTED PREEMPT (1-10)..... STOP TIME (Y/N)..... FLASH SENSE (Y/N)..... DOOR OPEN (Y/N)..... MANUAL CONTROL ENABLE (Y/N)..... MANUAL CONTROL ADVANCE (Y/N)..... SPECIAL FUNCTION ALARM (1-8)..... TOD HOUR SYNCHRONIZATION (0-23)..... FORCE OFF RING (1-4)..... HOLD PHASES (1-16)..... PLAN (65=FLSH,66=FREE)... OFFSET#... CHANGE PHASE SEQUENCE PAGE (1-12)... CHANGE PHASE TIMING PAGE (1-4)... CHANGE PHASE CONTROL PAGE (1-4)... CHANGE OVERLAP CONTROL PAGE (1-4)... CHANGE INPUT PAGE (1-4)... CHANGE OUTPUT PAGE (1-4)... OVERRIDE PHASE CONTROL FUNCTION (Y)...

PRESS '+' TO ADVANCE TO INPUT 18

PAGE: 2 C1 PIN:56 VEHICLE DETECTOR INPUT ASSIGNMENT #.....18 DEBOUNCE TIME (0-25.5 SEC).....0.5 DELAY TIME (0-25.5 SEC).....0.0 HOLD-OVER TIME (0-25.5 SEC).....0.0 ASSIGNMENT SELECTION: NOT ENABLED (Y/N)..... VEHICLE DETECTOR (1-64).....1 PEDESTRIAN DETECTOR (1-16)..... ALTERNATE PED DETECTOR (1-16)..... PREEMPT (1-10)..... INVERTED PREEMPT (1-10)..... STOP TIME (Y/N)..... FLASH SENSE (Y/N)..... DOOR OPEN (Y/N)..... MANUAL CONTROL ENABLE (Y/N)..... MANUAL CONTROL ADVANCE (Y/N)..... SPECIAL FUNCTION ALARM (1-8)..... TOD HOUR SYNCHRONIZATION (0-23)..... FORCE OFF RING (1-4)..... HOLD PHASES (1-16)..... PLAN (65=FLSH,66=FREE)... OFFSET#... CHANGE PHASE SEQUENCE PAGE (1-12)... CHANGE PHASE TIMING PAGE (1-4)... CHANGE PHASE CONTROL PAGE (1-4)... CHANGE OVERLAP CONTROL PAGE (1-4)... CHANGE INPUT PAGE (1-4)... CHANGE OUTPUT PAGE (1-4)... OVERRIDE PHASE CONTROL FUNCTION (Y)...

ENTER '51' TO REASSIGN THE VEHICLE DETECTOR FOR THIS INPUT

(LOOP 1A - PHASE 1)

PAGE: 2 C1 PIN:56 VEHICLE DETECTOR INPUT ASSIGNMENT #.....18 DEBOUNCE TIME (0-25.5 SEC).....0.5 DELAY TIME (0-25.5 SEC).....0.0 HOLD-OVER TIME (0-25.5 SEC).....0.0 ASSIGNMENT SELECTION: NOT ENABLED (Y/N)..... VEHICLE DETECTOR (1-64).....51 PEDESTRIAN DETECTOR (1-16)..... ALTERNATE PED DETECTOR (1-16)..... PREEMPT (1-10)..... INVERTED PREEMPT (1-10)..... STOP TIME (Y/N)..... FLASH SENSE (Y/N)..... DOOR OPEN (Y/N)..... MANUAL CONTROL ENABLE (Y/N)..... MANUAL CONTROL ADVANCE (Y/N)..... SPECIAL FUNCTION ALARM (1-8)..... TOD HOUR SYNCHRONIZATION (0-23)..... FORCE OFF RING (1-4)..... HOLD PHASES (1-16)..... PLAN (65=FLSH,66=FREE)... OFFSET#... CHANGE PHASE SEQUENCE PAGE (1-12)... CHANGE PHASE TIMING PAGE (1-4)... CHANGE PHASE CONTROL PAGE (1-4)... CHANGE OVERLAP CONTROL PAGE (1-4)... CHANGE INPUT PAGE (1-4)... CHANGE OUTPUT PAGE (1-4)... OVERRIDE PHASE CONTROL FUNCTION (Y)...

PROGRAMMING COMPLETE

SPECIAL DETECTOR PROGRAMMING DETAIL - LOOP 1A (ALT.)

(program controller as shown below)

FROM MAIN MENU PRESS '7' (DETECTORS). THEN PRESS '1' FOR VEHICLE DETECTORS. PRESS THE '-' KEY TO GET TO VEHICLE DETECTOR #51.

VEHICLE DETECTOR #51 SETTINGS (+,-,1-64) SETTING: (Y/N) ENABLE DETECTOR.....N ENABLE LOGGING.....N ENABLE DIAGNOSTICS.....N SPEED TRAP.....N CALL DETECTOR.....Y EXTENSION DETECTOR.....Y MODE 2 STOP BAR.....N SWITCHING DETECTOR.....N DUPLICATING DETECTOR.....N ENABLE FULL TIME DELAY.....N IF FAILED, SET MIN RECALL?.....N IF FAILED, SET MAX1 RECALL?.....N IF FAILED, SET MAX2 RECALL?.....N PHASE# :12345678910111213141516 PHASES ASSIGNED : SWITCH/DUPLICATE: LOOP SIZE (0-255 FT).....6 SPEED TRAP DISTANCE (0-255 FT).....0 STOP BAR TIME (0-255 SEC).....0 STRETCH (0-25.5 SEC).....0.0 DELAY (0-255 SEC).....0 MAX CALLS/MIN (0-255).....255 MIN CALLS/DIAGNOSTIC PERIOD (0-255).....0 MAX OCCUPANCY (0-100%).....100 EXTENSION DISABLE TIME (0-255 SEC).....0 QUEUE MAX OCCUPANCY TIME (0-255).....0 QUEUE GAP RESET TIME (0-25.5).....0.0 PREEMPTION INDEX FOR QUEUE (0-10).....0

ENTER 'Y' FOR ENABLE DETECTOR

ENTER '1' FOR PHASES ASSIGNED

ENSURE DELAY IS '3'

VEHICLE DETECTOR #51 SETTINGS (+,-,1-64) SETTING: (Y/N) ENABLE DETECTOR.....Y ENABLE LOGGING.....N ENABLE DIAGNOSTICS.....N SPEED TRAP.....N CALL DETECTOR.....Y EXTENSION DETECTOR.....Y MODE 2 STOP BAR.....N SWITCHING DETECTOR.....N DUPLICATING DETECTOR.....N ENABLE FULL TIME DELAY.....N IF FAILED, SET MIN RECALL?.....N IF FAILED, SET MAX1 RECALL?.....N IF FAILED, SET MAX2 RECALL?.....N PHASE# :12345678910111213141516 PHASES ASSIGNED :X SWITCH/DUPLICATE: LOOP SIZE (0-255 FT).....6 SPEED TRAP DISTANCE (0-255 FT).....0 STOP BAR TIME (0-255 SEC).....0 STRETCH (0-25.5 SEC).....0.0 DELAY (0-255 SEC).....3 MAX CALLS/MIN (0-255).....255 MIN CALLS/DIAGNOSTIC PERIOD (0-255).....0 MAX OCCUPANCY (0-100%).....100 EXTENSION DISABLE TIME (0-255 SEC).....0 QUEUE MAX OCCUPANCY TIME (0-255).....0 QUEUE GAP RESET TIME (0-25.5).....0.0 PREEMPTION INDEX FOR QUEUE (0-10).....0

NOTE: DETECTOR IS PROGRAMMED PER THE INPUT FILE CONNECTION AND PROGRAMMING CHART SHOWN ON SHEET 1.

THIS ELECTRICAL DETAIL IS FOR THE SIGNAL DESIGN: 03-0901T1 DESIGNED: June 2017 SEALED: 9/10/2021 REVISED: N/A

DETECTOR PROGRAMMING COMPLETE



HNTB NORTH CAROLINA, P.C. 343 E. Six Forks Road, Suite 200 Raleigh, North Carolina 27609 NC License No: C-1564 (919) 546-8997

Electrical Detail - Sheet 3 of 5 Signal Upgrade Temporary Design 1

DOCUMENT NOT CONSIDERED FINAL UNLESS ALL SIGNATURES COMPLETED

Table with project details: NC 211 (Southport-Supply Road) at NC 906 (Midway Road/Middleton Boulevard), Division 03 Brunswick Co. Southport. Includes dates, signatures, and a professional seal for Natasha R. Simmons, Engineer, No. 031464.

INPUT PAGE 2 ASSIGNMENT PROGRAMMING DETAIL FOR ALTERNATE PHASING - LOOP 5A

(program controller as shown below)

- NOTES: 1. THIS PROGRAMMING APPLIES FOR INPUT PAGE 2 ONLY. INPUT PAGE 1 WILL USE STANDARD DEFAULT SETTINGS. THIS PROGRAMMING IS NECESSARY FOR PROPER DETECTOR OPERATION DURING ALTERNATE PHASING OPERATION. 2. THE FIRST TASK THIS PROGRAMMING ACCOMPLISHES IS THE DISABLING OF INPUT #9 (DETECTOR 22) SO THAT A VEHICLE CALL WILL NOT BE PLACED TO PHASE 2 DURING ALTERNATE PHASING OPERATION. THE SECOND TASK THIS PROGRAMMING ACCOMPLISHES IS THAT IT REASSIGNS DETECTOR 55 TO INPUT #17 SO THAT THE DELAY ON LOOP 5A CAN BE REDUCED FROM 15 SECONDS TO 3 SECONDS.

FROM MAIN MENU PRESS '5' (INPUTS), THEN PRESS 'NEXT' TO GET TO INPUT PAGE '2'. PRESS THE '+' KEY UNTIL INPUT 9 IS REACHED.

PAGE: 2 C1 PIN:47 VEHICLE DETECTOR INPUT ASSIGNMENT #.....9 DEBOUNCE TIME (0-25.5 SEC).....0.5 DELAY TIME (0-25.5 SEC).....0.0 HOLD-OVER TIME (0-25.5 SEC).....0.0 ASSIGNMENT SELECTION: NOT ENABLED (Y/N).....Y VEHICLE DETECTOR (1-64).....22 PEDESTRIAN DETECTOR (1-16)..... ALTERNATE PED DETECTOR (1-16)..... PREEMPT (1-10)..... INVERTED PREEMPT (1-10)..... STOP TIME (Y/N)..... FLASH SENSE (Y/N)..... DOOR OPEN (Y/N)..... MANUAL CONTROL ENABLE (Y/N)..... MANUAL CONTROL ADVANCE (Y/N)..... SPECIAL FUNCTION ALARM (1-8)..... TOD HOUR SYNCHRONIZATION (0-23)..... FORCE OFF RING (1-4)..... HOLD PHASES (1-16)..... PLAN (65=FLSH,66=FREE)..... OFFSET#... CHANGE PHASE SEQUENCE PAGE (1-12).... CHANGE PHASE TIMING PAGE (1-4)..... CHANGE PHASE CONTROL PAGE (1-4).... CHANGE OVERLAP CONTROL PAGE (1-4).... CHANGE INPUT PAGE (1-4)..... CHANGE OUTPUT PAGE (1-4)..... OVERRIDE PHASE CONTROL FUNCTION (Y)...

ENTER A 'Y' FOR NOT ENABLED
DEFAULT DETECTOR NUMBER WILL REMAIN UNTIL 'NOT ENABLED' IS ENTERED.

(LOOP 5A - PHASE 2)

PAGE: 2 C1 PIN:47 NOT ENABLED INPUT ASSIGNMENT #.....9 DEBOUNCE TIME (0-25.5 SEC).....0.5 DELAY TIME (0-25.5 SEC).....0.0 HOLD-OVER TIME (0-25.5 SEC).....0.0 ASSIGNMENT SELECTION: NOT ENABLED (Y/N).....Y VEHICLE DETECTOR (1-64)..... PEDESTRIAN DETECTOR (1-16)..... ALTERNATE PED DETECTOR (1-16)..... PREEMPT (1-10)..... INVERTED PREEMPT (1-10)..... STOP TIME (Y/N)..... FLASH SENSE (Y/N)..... DOOR OPEN (Y/N)..... MANUAL CONTROL ENABLE (Y/N)..... MANUAL CONTROL ADVANCE (Y/N)..... SPECIAL FUNCTION ALARM (1-8)..... TOD HOUR SYNCHRONIZATION (0-23)..... FORCE OFF RING (1-4)..... HOLD PHASES (1-16)..... PLAN (65=FLSH,66=FREE)..... OFFSET#... CHANGE PHASE SEQUENCE PAGE (1-12).... CHANGE PHASE TIMING PAGE (1-4)..... CHANGE PHASE CONTROL PAGE (1-4).... CHANGE OVERLAP CONTROL PAGE (1-4).... CHANGE INPUT PAGE (1-4)..... CHANGE OUTPUT PAGE (1-4)..... OVERRIDE PHASE CONTROL FUNCTION (Y)...

PRESS '+' TO ADVANCE TO INPUT 17

PAGE: 2 C1 PIN:55 VEHICLE DETECTOR INPUT ASSIGNMENT #.....17 DEBOUNCE TIME (0-25.5 SEC).....0.5 DELAY TIME (0-25.5 SEC).....0.0 HOLD-OVER TIME (0-25.5 SEC).....0.0 ASSIGNMENT SELECTION: NOT ENABLED (Y/N)..... VEHICLE DETECTOR (1-64).....5 PEDESTRIAN DETECTOR (1-16)..... ALTERNATE PED DETECTOR (1-16)..... PREEMPT (1-10)..... INVERTED PREEMPT (1-10)..... STOP TIME (Y/N)..... FLASH SENSE (Y/N)..... DOOR OPEN (Y/N)..... MANUAL CONTROL ENABLE (Y/N)..... MANUAL CONTROL ADVANCE (Y/N)..... SPECIAL FUNCTION ALARM (1-8)..... TOD HOUR SYNCHRONIZATION (0-23)..... FORCE OFF RING (1-4)..... HOLD PHASES (1-16)..... PLAN (65=FLSH,66=FREE)..... OFFSET#... CHANGE PHASE SEQUENCE PAGE (1-12).... CHANGE PHASE TIMING PAGE (1-4)..... CHANGE PHASE CONTROL PAGE (1-4).... CHANGE OVERLAP CONTROL PAGE (1-4).... CHANGE INPUT PAGE (1-4)..... CHANGE OUTPUT PAGE (1-4)..... OVERRIDE PHASE CONTROL FUNCTION (Y)...

ENTER '55' TO REASSIGN THE VEHICLE DETECTOR FOR THIS INPUT

(LOOP 5A - PHASE 5)

PAGE: 2 C1 PIN:55 VEHICLE DETECTOR INPUT ASSIGNMENT #.....17 DEBOUNCE TIME (0-25.5 SEC).....0.5 DELAY TIME (0-25.5 SEC).....0.0 HOLD-OVER TIME (0-25.5 SEC).....0.0 ASSIGNMENT SELECTION: NOT ENABLED (Y/N)..... VEHICLE DETECTOR (1-64).....55 PEDESTRIAN DETECTOR (1-16)..... ALTERNATE PED DETECTOR (1-16)..... PREEMPT (1-10)..... INVERTED PREEMPT (1-10)..... STOP TIME (Y/N)..... FLASH SENSE (Y/N)..... DOOR OPEN (Y/N)..... MANUAL CONTROL ENABLE (Y/N)..... MANUAL CONTROL ADVANCE (Y/N)..... SPECIAL FUNCTION ALARM (1-8)..... TOD HOUR SYNCHRONIZATION (0-23)..... FORCE OFF RING (1-4)..... HOLD PHASES (1-16)..... PLAN (65=FLSH,66=FREE)..... OFFSET#... CHANGE PHASE SEQUENCE PAGE (1-12).... CHANGE PHASE TIMING PAGE (1-4)..... CHANGE PHASE CONTROL PAGE (1-4).... CHANGE OVERLAP CONTROL PAGE (1-4).... CHANGE INPUT PAGE (1-4)..... CHANGE OUTPUT PAGE (1-4)..... OVERRIDE PHASE CONTROL FUNCTION (Y)...

PROGRAMMING COMPLETE

SPECIAL DETECTOR PROGRAMMING DETAIL - LOOP 5A (ALT.)

(program controller as shown below)

FROM MAIN MENU PRESS '7' (DETECTORS), THEN PRESS '1' FOR VEHICLE DETECTORS. PRESS THE '-' KEY TO GET TO VEHICLE DETECTOR #55.

VEHICLE DETECTOR #55 SETTINGS (+,-,1-64) SETTING: (Y/N) ENABLE DETECTOR.....N ENABLE LOGGING.....N ENABLE DIAGNOSTICS.....N SPEED TRAP.....N CALL DETECTOR.....Y EXTENSION DETECTOR.....Y MODE 2 STOP BAR.....N SWITCHING DETECTOR.....N DUPLICATING DETECTOR.....N ENABLE FULL TIME DELAY.....N IF FAILED, SET MIN RECALL?.....N IF FAILED, SET MAX1 RECALL?.....N IF FAILED, SET MAX2 RECALL?.....N PHASE# :12345678910111213141516 PHASES ASSIGNED : SWITCH/DUPLICATE: LOOP SIZE (0-255 FT).....6 SPEED TRAP DISTANCE (0-255 FT).....0 STOP BAR TIME (0-255 SEC).....0 STRETCH (0-25.5 SEC).....0.0 DELAY (0-255 SEC).....0.0 MAX CALLS/MIN (0-255).....255 MIN CALLS/DIAGNOSTIC PERIOD (0-255).....0 MAX OCCUPANCY (0-100%).....100 EXTENSION DISABLE TIME (0-255 SEC).....0 QUEUE MAX OCCUPANCY TIME (0-255).....0 QUEUE GAP RESET TIME (0-25.5).....0.0 PREEMPTION INDEX FOR QUEUE (0-10).....0

ENTER 'Y' FOR ENABLE DETECTOR

ENTER '5' FOR PHASES ASSIGNED

ENSURE DELAY IS '3'

VEHICLE DETECTOR #55 SETTINGS (+,-,1-64) SETTING: (Y/N) ENABLE DETECTOR.....Y ENABLE LOGGING.....N ENABLE DIAGNOSTICS.....N SPEED TRAP.....N CALL DETECTOR.....Y EXTENSION DETECTOR.....Y MODE 2 STOP BAR.....N SWITCHING DETECTOR.....N DUPLICATING DETECTOR.....N ENABLE FULL TIME DELAY.....N IF FAILED, SET MIN RECALL?.....N IF FAILED, SET MAX1 RECALL?.....N IF FAILED, SET MAX2 RECALL?.....N PHASE# :12345678910111213141516 PHASES ASSIGNED : X SWITCH/DUPLICATE: LOOP SIZE (0-255 FT).....6 SPEED TRAP DISTANCE (0-255 FT).....0 STOP BAR TIME (0-255 SEC).....0 STRETCH (0-25.5 SEC).....0.0 DELAY (0-255 SEC).....3 MAX CALLS/MIN (0-255).....255 MIN CALLS/DIAGNOSTIC PERIOD (0-255).....0 MAX OCCUPANCY (0-100%).....100 EXTENSION DISABLE TIME (0-255 SEC).....0 QUEUE MAX OCCUPANCY TIME (0-255).....0 QUEUE GAP RESET TIME (0-25.5).....0.0 PREEMPTION INDEX FOR QUEUE (0-10).....0

DETECTOR PROGRAMMING COMPLETE

NOTE: DETECTOR IS PROGRAMMED PER THE INPUT FILE CONNECTION AND PROGRAMMING CHART SHOWN ON SHEET 1.

THIS ELECTRICAL DETAIL IS FOR THE SIGNAL DESIGN: 03-0901T1 DESIGNED: June 2017 SEALED: 9/10/2021 REVISED: N/A

Electrical Detail - Sheet 4 of 5
Signal Upgrade
Temporary Design 1

DOCUMENT NOT CONSIDERED FINAL UNLESS ALL SIGNATURES COMPLETED

Table with project details: NC 211 (Southport-Supply Road) at NC 906 (Midway Road/Middleton Boulevard), Division 03 Brunswick Co. Southport. Includes dates (June 2017, 9/10/2021), signatures (A.H. Thornburg, N.R. Simmons, Natasha Simmons), and a professional seal for Natasha R. Simmons, Engineer No. 031464.

ALTERNATE PHASING ACTIVATION DETAIL

TO RUN ALT. PHASING DURING COORDINATION - SELECT ALL PAGE CHANGES (AS SHOWN BELOW) WITHIN COORDINATION PLAN PROGRAMMING.

TO RUN ALT. PHASING DURING FREE RUN - PROGRAM PAGE CHANGES (SHOWN BELOW) IN SEPARATE TIME OF DAY EVENTS. IF PAGE 1 IS USED, NO EVENT PROGRAMMING IS NECESSARY FOR THAT PARTICULAR PAGE.

<u>PHASING</u>	<u>INPUTS PAGE</u>	<u>OVERLAPS PAGE</u>
ACTIVE PAGES REQUIRED TO RUN <u>DEFAULT PHASING</u>	1	1
ACTIVE PAGES REQUIRED TO RUN <u>ALTERNATE PHASING</u>	2	2

NOTE: PAGES NOT SHOWN (i.e. sequence, phase control, etc.) SHOULD REMAIN AS '1', OR AS DEFINED BY TIMING ENGINEER.

IMPORTANT: IF ALT. PHASING IS USED DURING FREE RUN AND COORDINATION, DO NOT OPERATE TIME OF DAY PAGE CHANGE EVENTS CONCURRENTLY WITH COORDINATION PLAN EVENTS IN THE EVENT SCHEDULER. (EX. FREE RUN PAGE CHANGE EVENT SHOULD END BEFORE COORDINATION PLAN EVENT STARTS AND VICE-VERSA).

ALTERNATE PHASING PAGE CHANGE SUMMARY

THE FOLLOWING IS A SUMMARY OF WHAT TAKES PLACE WHEN THESE OVERLAP/INPUT PAGE CHANGES ACTIVATE TO CALL THE "ALTERNATE PHASING":

OVERLAPS PAGE 2: Modifies overlap parent phases for heads 11 and 51 to run protected turns only.

INPUTS PAGE 2: Disables phase 6 call on loop 1A and reduces delay time for phase 1 call on loop 1A to 3 seconds.

Disables phase 2 call on loop 5A and reduces delay time for phase 5 call on loop 5A to 3 seconds.

THIS ELECTRICAL DETAIL IS FOR
 THE SIGNAL DESIGN: 03-0901T1
 DESIGNED: June 2017
 SEALED: 9/10/2021
 REVISED: N/A

Electrical Detail - Sheet 5 of 5
 Signal Upgrade
 Temporary Design 1

**DOCUMENT NOT CONSIDERED FINAL
 UNLESS ALL SIGNATURES COMPLETED**

HNTB HNTB NORTH CAROLINA, P.C.
 343 E. Six Forks Road, Suite 200
 Raleigh, North Carolina 27609
 NC License No: C-1554
 (919) 546-8997

<p style="font-size: small;">ELECTRICAL AND PROGRAMMING DETAILS FOR:</p> <p style="text-align: center;">Prepared for: Department of Transportation State of North Carolina</p> <p style="font-size: x-small;">750 N. Greenfield Pkwy, Corner, NC 27529</p>	<p>NC 211 (Southport-Supply Road) at NC 906 (Midway Road/ Middleton Boulevard)</p> <p style="font-size: x-small;">Division 03 Brunswick Co. Southport</p> <p style="font-size: x-small;">PLAN DATE: June 2017 REVIEWED BY: A.D. Klinksiek</p> <p style="font-size: x-small;">PREPARED BY: A.H. Thornburg REVIEWED BY: N.R. Simmons</p>	<p style="text-align: center;">SEAL</p> <p style="text-align: center;">NORTH CAROLINA PROFESSIONAL SEAL 031464 ENGINEER NATASHA R. SIMMONS</p> <p style="font-size: x-small;">DocuSigned by: Natasha Simmons 9/10/2021</p> <p style="font-size: x-small;">SIGNATURE DATE</p> <p style="font-size: x-small;">SIG. INVENTORY NO. 03-0901T1</p>
--	---	---

SIGNAL FACE I.D.

All Heads L.E.D.

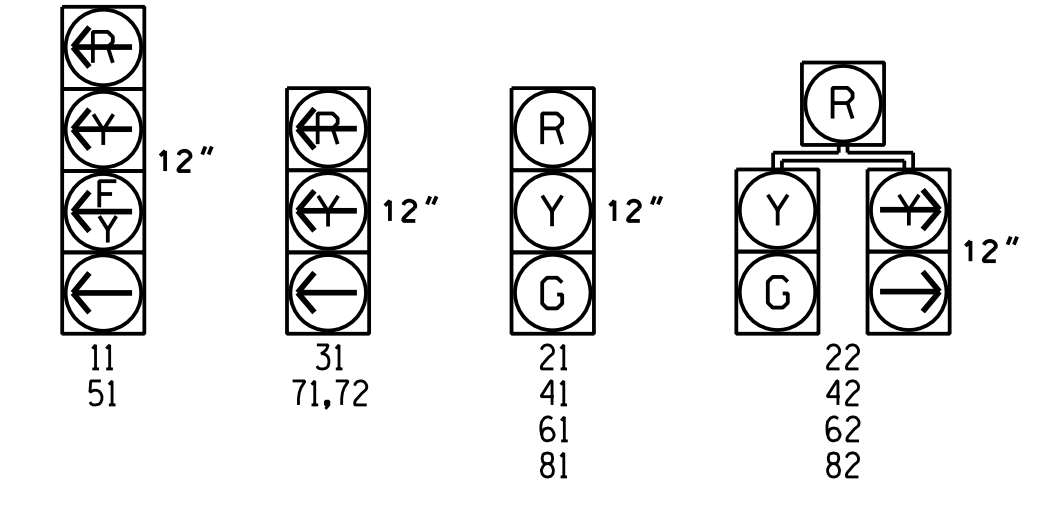

ALTERNATE PHASING DIAGRAM

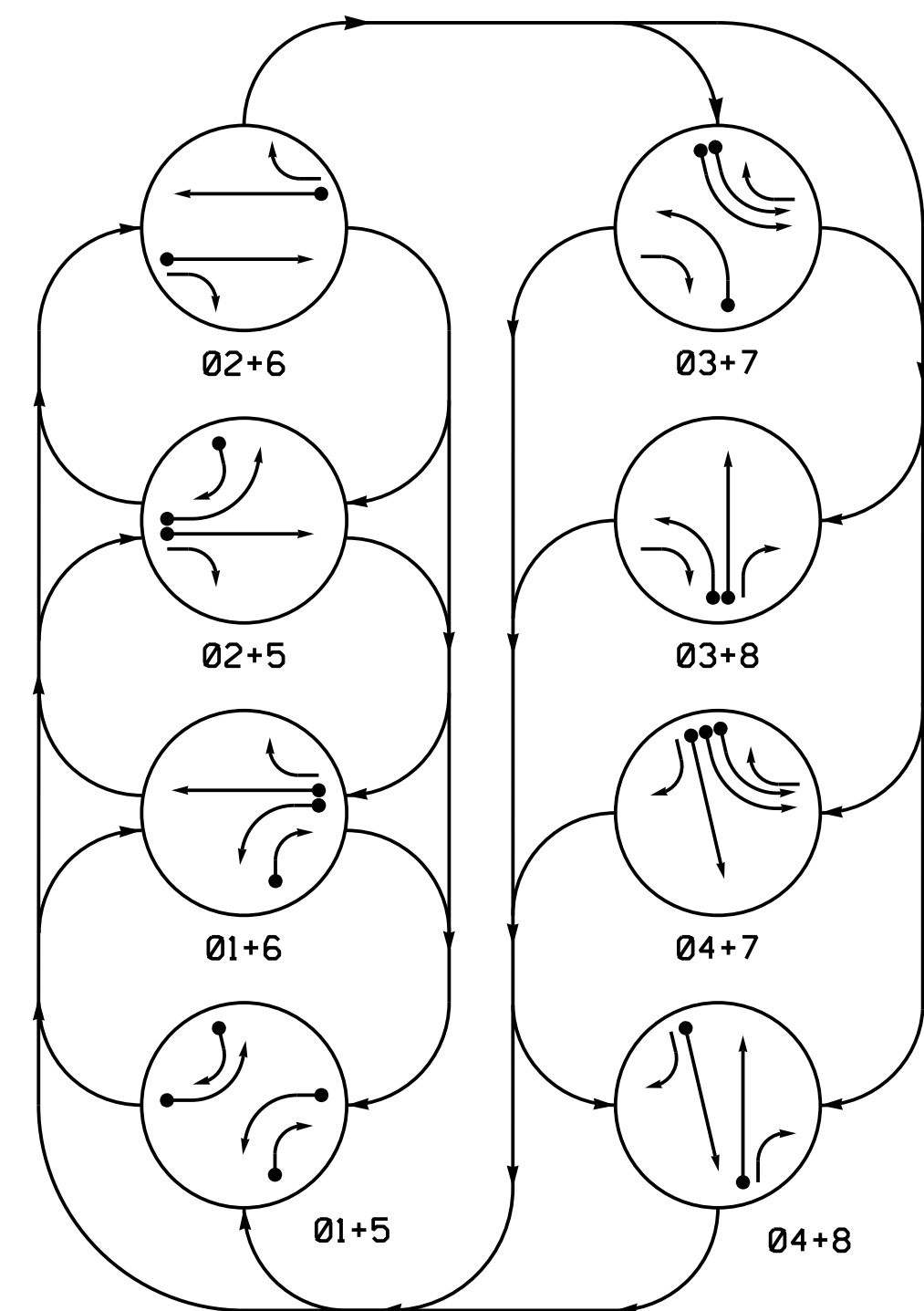

PHASING DIAGRAM DETECTION LEGEND

- ←● UNDETECTED MOVEMENT (OVERLAP)
- ← UNDETECTED MOVEMENT (OVERLAP)
- ←..... UNSIGNALIZED MOVEMENT
- ←- - - - PEDESTRIAN MOVEMENT

ALTERNATE PHASING TABLE OF OPERATION

SIGNAL FACE	PHASE								F L	
	01+5	01+6	02+5	02+6	03+7	03+8	04+7	04+8		
11	—	—	—	—	—	—	—	—	—	Y
21	R	R	G	G	R	R	R	R	R	Y
22	R	R	G	G	R	R	R	R	R	Y
31	—	—	—	—	—	—	—	—	—	—
41	R	R	R	R	R	R	G	G	R	—
42	R	R	R	R	R	R	G	G	R	—
51	—	—	—	—	—	—	—	—	—	Y
61	R	G	R	G	R	R	R	R	Y	—
62	R	G	R	G	R	R	R	Y	—	—
71,72	—	—	—	—	—	—	—	—	—	—
81	R	R	R	R	R	G	R	G	R	—
82	R	R	R	R	R	G	R	G	R	—

Signal Upgrade
 Temporary Design 2
 Construction Phase 1a-1b
 Sheet 2 of 2

**DOCUMENT NOT CONSIDERED FINAL
 UNLESS ALL SIGNATURES COMPLETED**

HNTB HNTB NORTH CAROLINA, P.C.
 343 E. Six Forks Road, Suite 200
 Raleigh, North Carolina 27609
 NC License No: C-1554
 (919) 546-8997

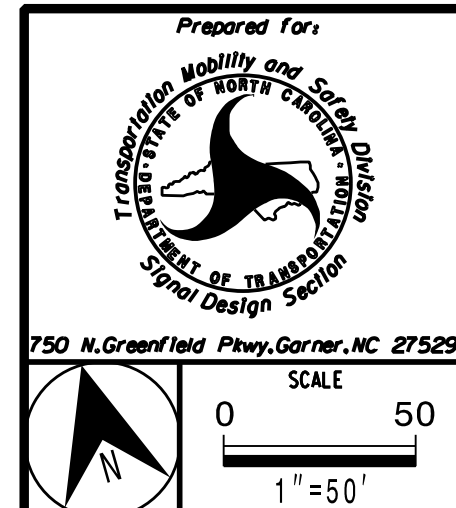

Prepared for: 750 N. Greenfield Pkwy, Garner, NC 27529		NC 211 (Southport-Supply Road) at NC 906 (Midway Road/ Middleton Boulevard)	
Division 03 Brunswick Co. Southport		Division 03 Brunswick Co. Southport	
PLAN DATE: June 2017	REVIEWED BY: A.D. Klinksiek	PREPARED BY: A.H. Thornburg	REVIEWED BY: N.R. Simmons
REVISIONS	INIT.	DATE	

SEAL
 NORTH CAROLINA
 PROFESSIONAL
 ENGINEER
 NATASHA R. SIMMONS
 SEAL
 031464
 Signature: Natasha Simmons
 Date: 9/10/2021
 SIG. INVENTORY NO. 03-0901T2

EDI MODEL 2018ECL-NC CONFLICT MONITOR PROGRAMMING DETAIL

(remove jumpers and set switches as shown)

REMOVE DIODE JUMPERS 1-5, 1-6, 1-9, 1-11, 2-5, 2-6, 2-9, 2-11, 3-7, 3-8, 4-7, 4-8, 5-9, 5-11, 6-9, 6-11 and 9-11.

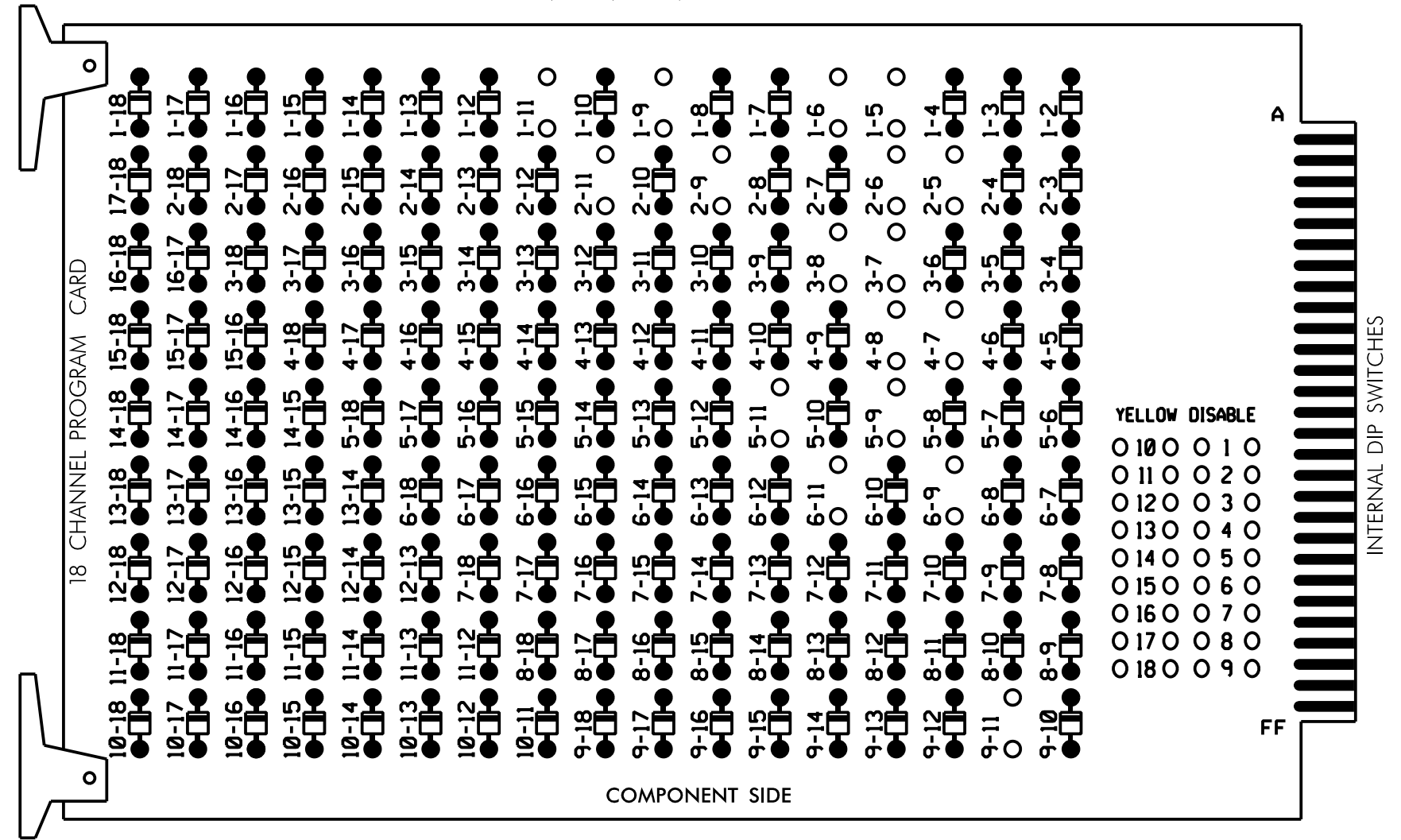

REMOVE JUMPERS AS SHOWN

NOTES:

- Card is provided with all diode jumpers in place. Removal of any jumper allows its channels to run concurrently.
- Ensure jumpers SEL2-SEL5 and SEL9 are present on the monitor board.
- Ensure that Red Enable is active at all times during normal operation.
- Connect serial cable from conflict monitor to comm. port 1 of 2070 controller. Ensure conflict monitor communicates with 2070.

NOTES

- To prevent "flash-conflict" problems, insert red flash program blocks for all unused vehicle load switches in the output file. The installer shall verify that signal heads flash in accordance with the Signal Plans.
- Enable Simultaneous Gap-Out for all Phases.
- Program phases 2 and 6 for Variable Initial and phases 2,4,6, and 8 for Gap Reduction.
- Program phases 2 and 6 for Startup In Green.
- Program phases 2 and 6 for Yellow Flash, and overlap 1 as Wag Overlaps.
- If this signal will be managed by an ATMS software, enable controller and detector logging for all detectors used at this location.

EQUIPMENT INFORMATION

CONTROLLER.....2070E
 CABINET.....332 W/ AUX
 SOFTWARE.....ECONOLITE OASIS
 CABINET MOUNT.....BASE
 OUTPUT FILE POSITIONS...18 WITH AUX. OUTPUT FILE
 LOAD SWITCHES USED.....S1,S2,S4,S5,S7,S8,S10,S11
 AUX S1,AUX S4
 PHASES USED.....1,2,3,4,5,6,7,8
 OVERLAP "A".....1+2
 OVERLAP "B".....NOT USED
 OVERLAP "C".....5+6
 OVERLAP "D".....NOT USED

SIGNAL HEAD HOOK-UP CHART

LOAD SWITCH NO.	S1	S2	S3	S4	S5	S6	S7	S8	S9	S10	S11	S12	AUX S1	AUX S2	AUX S3	AUX S4	AUX S5	AUX S6			
CMU CHANNEL NO.	1	2	13	3	4	14	5	6	15	7	8	16	9	10	17	11	12	18			
PHASE	1	2	2 PED	3	4	4 PED	5	6	6 PED	7	8	8 PED	OLA	OLB	SPARE	OLC	OLD	SPARE			
SIGNAL HEAD NO.	11	82	21,22	NU	22	31	41,42	NU	42	51	61,62	NU	62	71,72	81,82	NU	11	NU	51	NU	
RED		*	128			101		*		134				107							
YELLOW			129			102				135				108							
GREEN			130			103				136				109							
RED ARROW					116									122		A121		A114			
YELLOW ARROW		126			117	117			132				123	123		A122		A115			
FLASHING YELLOW ARROW																A123		A116			
GREEN ARROW	127	127			118	118			133	133			124	124							

NU = Not Used

- * Denotes install load resistor. See load resistor installation detail this sheet.
- ★ See pictorial of head wiring in detail this sheet.

INPUT FILE POSITION LAYOUT

(front view)

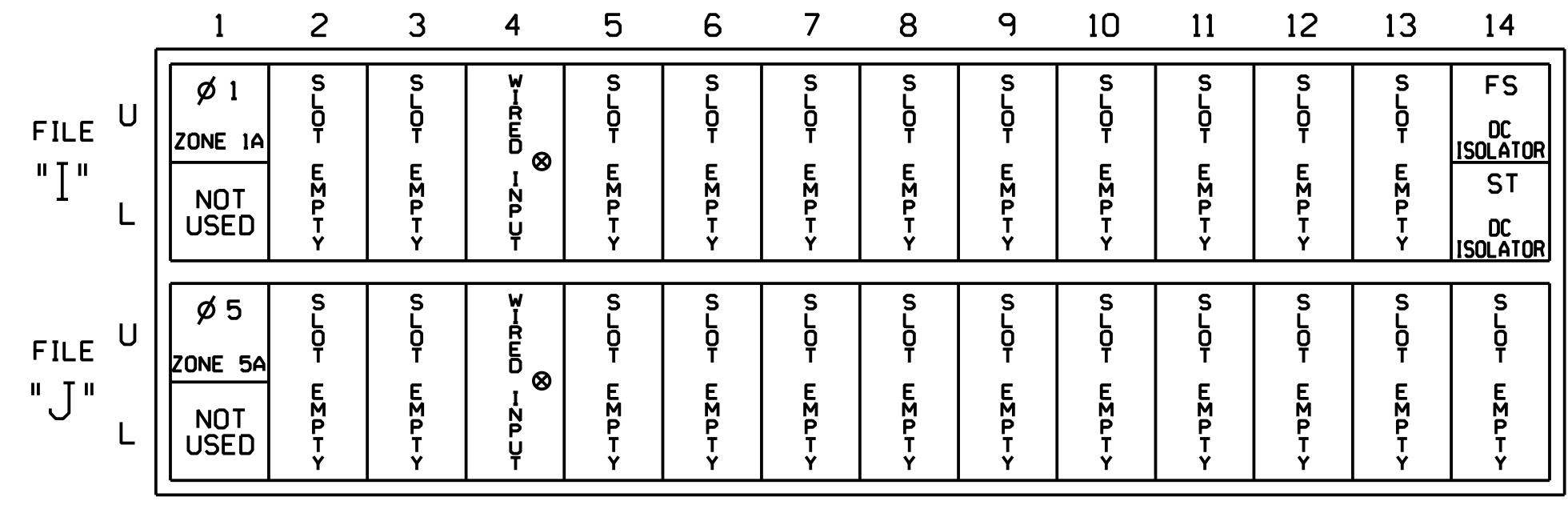

EX.: 1A, 2A, ETC. = LOOP NO.'S

FS = FLASH SENSE
 ST = STOP TIME

⊗ Wired Input - Do not populate slot with detector card

INPUT FILE CONNECTION & PROGRAMMING CHART

LOOP NO.	LOOP TERMINAL	INPUT FILE POS.	PIN NO.	INPUT ASSIGNMENT NO.	DETECTOR NO.	NEMA PHASE	CALL	EXTEND	FULL TIME DELAY	STRETCH TIME	DELAY TIME
ZONE 1A ¹	**	I1U	56	18	1	1	Y	Y			15
	-	J4U	48	10★	26	6	Y	Y	Y		3
ZONE 5A ²	**	I1U	56	18★	51	1	Y	Y			3
	-	J1U	55	17	5	5	Y	Y			15
ZONE 5A ²	-	I4U	47	9★	22	2	Y	Y	Y		3
	-	J1U	55	17★	55	5	Y	Y			3

- ¹Add jumper from I1-W to J4-W, on rear of input file.
- ²Add jumper from J1-W to I4-W, on rear of input file.
- * See Input Page Assignment programming details on sheets 3 and 4.
- ** Multizone Microwave Detector Zone. See Special Detector Note.

INPUT FILE POSITION LEGEND: J2L

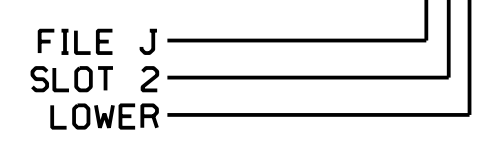

SPECIAL DETECTOR NOTE

Install a microwave detection system for vehicle detection. Perform installation according to manufacturer's directions and NCDOT engineer-approved mounting locations to accomplish the detection schemes shown on the Signal Design Plans.

For loops 1A and 5A detector card placement and slots reserved for wired inputs are typical for a NCDOT installation. Inputs associated with these slots are compatible with the time of day instructions located on sheets 3, 4, and 5 of this electrical detail.

FYA SIGNAL WIRING DETAIL

(wire signal heads as shown)

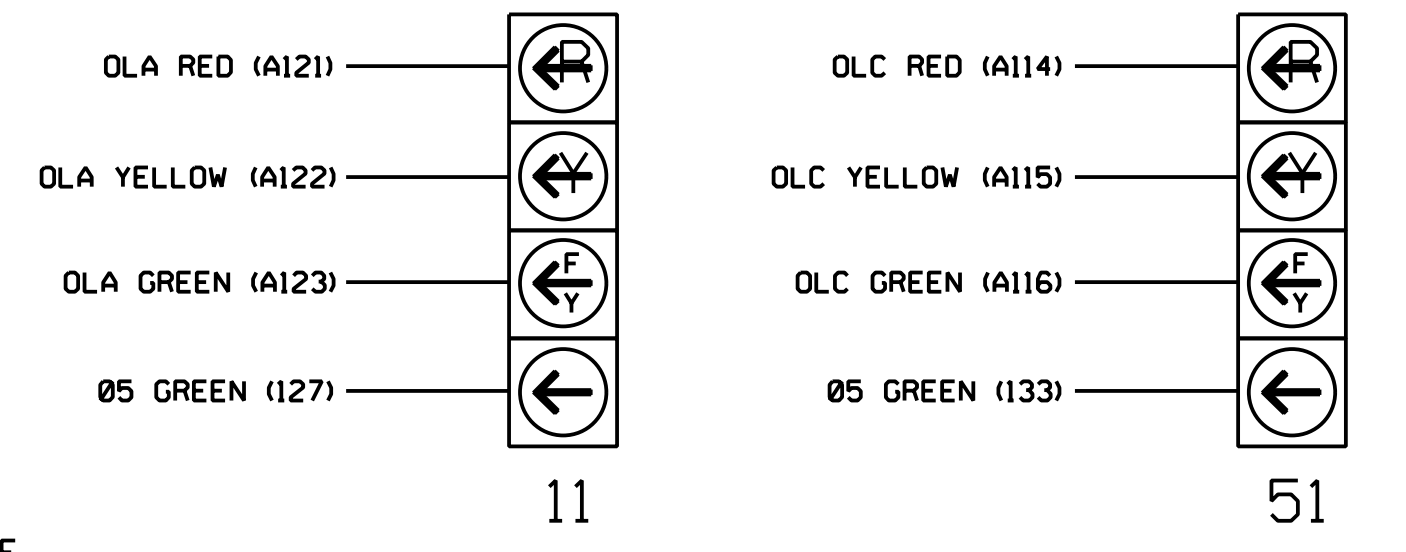

NOTE

The sequence display for signal heads 11 and 51 requires special logic programming. See sheet 2 for programming instructions.

LOAD RESISTOR INSTALLATION DETAIL

(install resistors as shown)

ACCEPTABLE VALUES	
VALUE (ohms)	WATTAGE
1.5K - 1.9K	25W (min)
2.0K - 3.0K	10W (min)

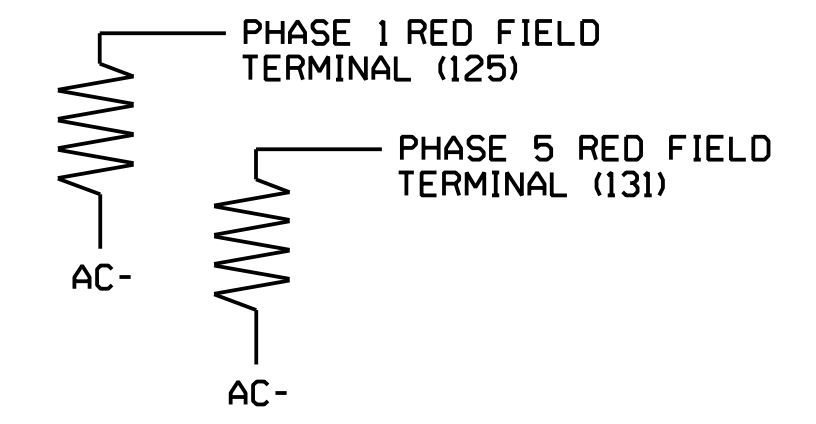

Electrical Detail - Sheet 1 of 5
 Signal Upgrade
 Temporary Design 2

DOCUMENT NOT CONSIDERED FINAL UNLESS ALL SIGNATURES COMPLETED

	NC 211 (Southport-Supply Road) at NC 906 (Midway Road/ Middleton Boulevard) Division 03 Brunswick Co. Southport		SEAL
	Prepared for: HNTB	Prepared by: A.H. Thornburg Reviewed by: N.R. Simmons	
Revisions table with columns: REVISIONS, INITI., DATE			DocuSigned by: Natasha Simmons 9/10/2021 SIGNATURE DATE SIG. INVENTORY NO. 03-0901T2

LOGICAL I/O PROCESSOR PROGRAMMING DETAIL TO PRODUCE SPECIAL FYA-PPLT SIGNAL SEQUENCE

(program controller as shown below)

- FROM MAIN MENU PRESS '2' (PHASE CONTROL), THEN '1' (PHASE CONTROL FUNCTIONS). SCROLL TO THE BOTTOM OF THE MENU AND ENABLE ACT LOGIC COMMANDS 1, 2, 3, 4, 5 AND 6.
- FROM MAIN MENU PRESS '6' (OUTPUTS), THEN '3' (LOGICAL I/O PROCESSOR).

```

LOGICAL I/O COMMAND #1 (+/-COMMAND#)
IF ACTIVE PHASE #1 IS ON
AND RED CLEAR ON PHASE #1 IS ON
↓
SCROLL DOWN
THEN:
SET OUTPUT ASSIGNMENT #50 ON
SET OUTPUT ASSIGNMENT #51 OFF
PRESS '+'
  
```

NOTE: LOGIC FOR PHASE 1 RED CLEAR WHEN TRANSITIONING FROM PHASE 1 TO PHASE 2 (HEAD 11).

```

LOGICAL I/O COMMAND #2 (+/-COMMAND#)
IF ACTIVE PHASE #1 IS ON
↓
SCROLL DOWN
THEN:
SET OUTPUT ASSIGNMENT #52 OFF
PRESS '+'
  
```

NOTE: LOGIC FOR SWITCHING FLASHING YELLOW ARROW "OFF" DURING PHASE 1 (HEAD 11).

```

LOGICAL I/O COMMAND #3 (+/-COMMAND#)
IF YELLOW ON PHASE #1 IS ON
↓
SCROLL DOWN
THEN:
SET OUTPUT ASSIGNMENT #51 ON
PRESS '+'
  
```

NOTE: LOGIC FOR YELLOW ARROW CLEARANCE FROM PHASE 1 (HEAD 11).

```

LOGICAL I/O COMMAND #4 (+/-COMMAND#)
IF ACTIVE PHASE #5 IS ON
AND RED CLEAR ON PHASE #5 IS ON
↓
SCROLL DOWN
THEN:
SET OUTPUT ASSIGNMENT #42 ON
SET OUTPUT ASSIGNMENT #43 OFF
PRESS '+'
  
```

NOTE: LOGIC FOR PHASE 5 RED CLEAR WHEN TRANSITIONING FROM PHASE 5 TO PHASE 6 (HEAD 51).

```

LOGICAL I/O COMMAND #5 (+/-COMMAND#)
IF ACTIVE PHASE #5 IS ON
↓
SCROLL DOWN
THEN:
SET OUTPUT ASSIGNMENT #44 OFF
PRESS '+'
  
```

NOTE: LOGIC FOR SWITCHING FLASHING YELLOW ARROW "OFF" DURING PHASE 5 (HEAD 51).

```

LOGICAL I/O COMMAND #6 (+/-COMMAND#)
IF YELLOW ON PHASE #5 IS ON
↓
SCROLL DOWN
THEN:
SET OUTPUT ASSIGNMENT #43 ON
PRESS '+'
  
```

NOTE: LOGIC FOR YELLOW ARROW CLEARANCE FROM PHASE 5 (HEAD 51).

LOGIC I/O PROCESSOR PROGRAMMING COMPLETE

OVERLAP PROGRAMMING DETAIL FOR DEFAULT PHASING

(program controller as shown below)

FROM MAIN MENU PRESS '8' (OVERLAPS), THEN '1' (VEHICLE OVERLAP SETTINGS).

```

PAGE 1: VEHICLE OVERLAP 'A' SETTINGS
PHASE: 12345678910111213141516
VEH OVL PARENTS: XX
VEH OVL NOT VEH: XX
VEH OVL NOT PED:
VEH OVL GRN EXT:
STARTUP COLOR: - RED - YELLOW - GREEN
FLASH COLORS: - RED - YELLOW X GREEN
SELECT VEHICLE OVERLAP OPTIONS: (Y/N)
FLASH YELLOW IN CONTROLLER FLASH?...Y
GREEN EXTENSION (0-255 SEC)...0.0
YELLOW CLEAR (0=PARENT,3-25.5 SEC)...0.0
RED CLEAR (0=PARENT,0.1-25.5 SEC)...0.0
OUTPUT AS PHASE # (0=NONE, 1-16)...0
  
```

NOTICE GREEN FLASH

PRESS '+' TWICE

```

PAGE 1: VEHICLE OVERLAP 'C' SETTINGS
PHASE: 12345678910111213141516
VEH OVL PARENTS: XX
VEH OVL NOT VEH: X
VEH OVL NOT PED:
VEH OVL GRN EXT:
STARTUP COLOR: - RED - YELLOW - GREEN
FLASH COLORS: - RED - YELLOW X GREEN
SELECT VEHICLE OVERLAP OPTIONS: (Y/N)
FLASH YELLOW IN CONTROLLER FLASH?...Y
GREEN EXTENSION (0-255 SEC)...0.0
YELLOW CLEAR (0=PARENT,3-25.5 SEC)...0.0
RED CLEAR (0=PARENT,0.1-25.5 SEC)...0.0
OUTPUT AS PHASE # (0=NONE, 1-16)...0
  
```

NOTICE GREEN FLASH

OVERLAP PROGRAMMING COMPLETE

OVERLAP PROGRAMMING DETAIL FOR ALTERNATE PHASING

(program controller as shown below)

FROM MAIN MENU PRESS '8' (OVERLAPS), THEN '1' (VEHICLE OVERLAP SETTINGS), PRESS 'NEXT' TO ADVANCE TO PAGE 2.

NOTICE PAGE 2

```

PAGE 2: VEHICLE OVERLAP 'A' SETTINGS
PHASE: 12345678910111213141516
VEH OVL PARENTS: X
VEH OVL NOT VEH:
VEH OVL NOT PED:
VEH OVL GRN EXT:
STARTUP COLOR: - RED - YELLOW - GREEN
FLASH COLORS: - RED - YELLOW - GREEN
SELECT VEHICLE OVERLAP OPTIONS: (Y/N)
FLASH YELLOW IN CONTROLLER FLASH?...Y
GREEN EXTENSION (0-255 SEC)...0.0
YELLOW CLEAR (0=PARENT,3-25.5 SEC)...0.0
RED CLEAR (0=PARENT,0.1-25.5 SEC)...0.0
OUTPUT AS PHASE # (0=NONE, 1-16)...0
  
```

PRESS '+' TWICE

NOTICE PAGE 2

```

PAGE 2: VEHICLE OVERLAP 'C' SETTINGS
PHASE: 12345678910111213141516
VEH OVL PARENTS: X
VEH OVL NOT VEH:
VEH OVL NOT PED:
VEH OVL GRN EXT:
STARTUP COLOR: - RED - YELLOW - GREEN
FLASH COLORS: - RED - YELLOW - GREEN
SELECT VEHICLE OVERLAP OPTIONS: (Y/N)
FLASH YELLOW IN CONTROLLER FLASH?...Y
GREEN EXTENSION (0-255 SEC)...0.0
YELLOW CLEAR (0=PARENT,3-25.5 SEC)...0.0
RED CLEAR (0=PARENT,0.1-25.5 SEC)...0.0
OUTPUT AS PHASE # (0=NONE, 1-16)...0
  
```

OVERLAP PROGRAMMING COMPLETE

OUTPUT REFERENCE SCHEDULE	
USE TO INTERPRET LOGIC PROCESSOR	
OUTPUT 42 =	Overlap C Red
OUTPUT 43 =	Overlap C Yellow
OUTPUT 44 =	Overlap C Green
OUTPUT 50 =	Overlap A Red
OUTPUT 51 =	Overlap A Yellow
OUTPUT 52 =	Overlap A Green

THIS ELECTRICAL DETAIL IS FOR THE SIGNAL DESIGN: 03-0901T2
 DESIGNED: June 2017
 SEALED: 9/10/2021
 REVISED: N/A

Electrical Detail - Sheet 2 of 5
Signal Upgrade
Temporary Design 2

DOCUMENT NOT CONSIDERED FINAL
UNLESS ALL SIGNATURES COMPLETED

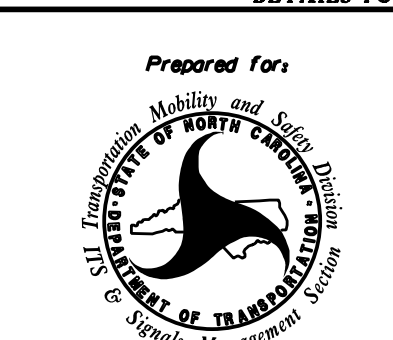
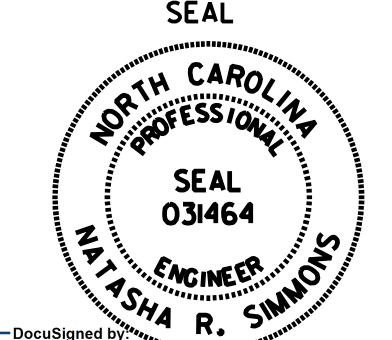
	Prepared for: NC 211 (Southport-Supply Road) at NC 906 (Midway Road/ Middleton Boulevard) Division 03 Brunswick Co. Southport		
	PLAN DATE: June 2017 PREPARED BY: A.H. Thornburg	REVIEWED BY: A.D. Klinksiek REVIEWED BY: N.R. Simmons	
REVISIONS			SIGNATURE DATE

HNTB HNTB NORTH CAROLINA, P.C.
 343 E. Six Forks Road, Suite 200
 Raleigh, North Carolina 27609
 NC License No: C-1554
 (919) 546-8997

INPUT PAGE 2 ASSIGNMENT PROGRAMMING DETAIL FOR ALTERNATE PHASING - LOOP 1A

(program controller as shown below)

- NOTES: 1. THIS PROGRAMMING APPLIES FOR INPUT PAGE 2 ONLY. INPUT PAGE 1 WILL USE STANDARD DEFAULT SETTINGS. THIS PROGRAMMING IS NECESSARY FOR PROPER DETECTOR OPERATION DURING ALTERNATE PHASING OPERATION.
2. THE FIRST TASK THIS PROGRAMMING ACCOMPLISHES IS THE DISABLING OF INPUT #10 (DETECTOR 26) SO THAT A VEHICLE CALL WILL NOT BE PLACED TO PHASE 6 DURING ALTERNATE PHASING OPERATION. THE SECOND TASK THIS PROGRAMMING ACCOMPLISHES IS THAT IT REASSIGNS DETECTOR 51 TO INPUT #18 SO THAT THE DELAY ON LOOP 1A CAN BE REDUCED FROM 15 SECONDS TO 3 SECONDS.

FROM MAIN MENU PRESS '5' (INPUTS). THEN PRESS 'NEXT' TO GET TO INPUT PAGE '2'. PRESS THE '+' KEY UNTIL INPUT 10 IS REACHED.

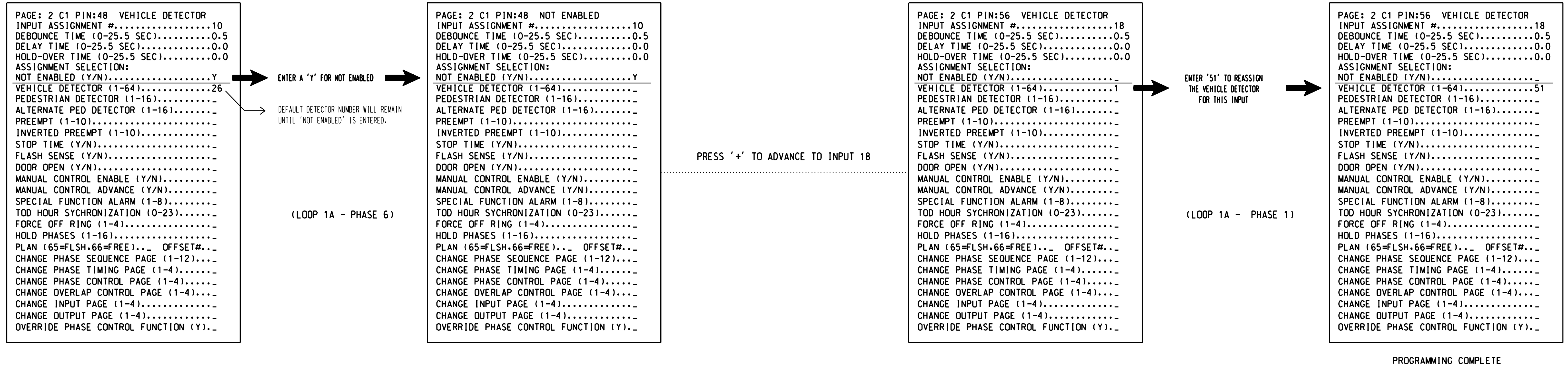

SPECIAL DETECTOR PROGRAMMING DETAIL - LOOP 1A (ALT.)

(program controller as shown below)

FROM MAIN MENU PRESS '7' (DETECTORS). THEN PRESS '1' FOR VEHICLE DETECTORS. PRESS THE '-' KEY TO GET TO VEHICLE DETECTOR #51.

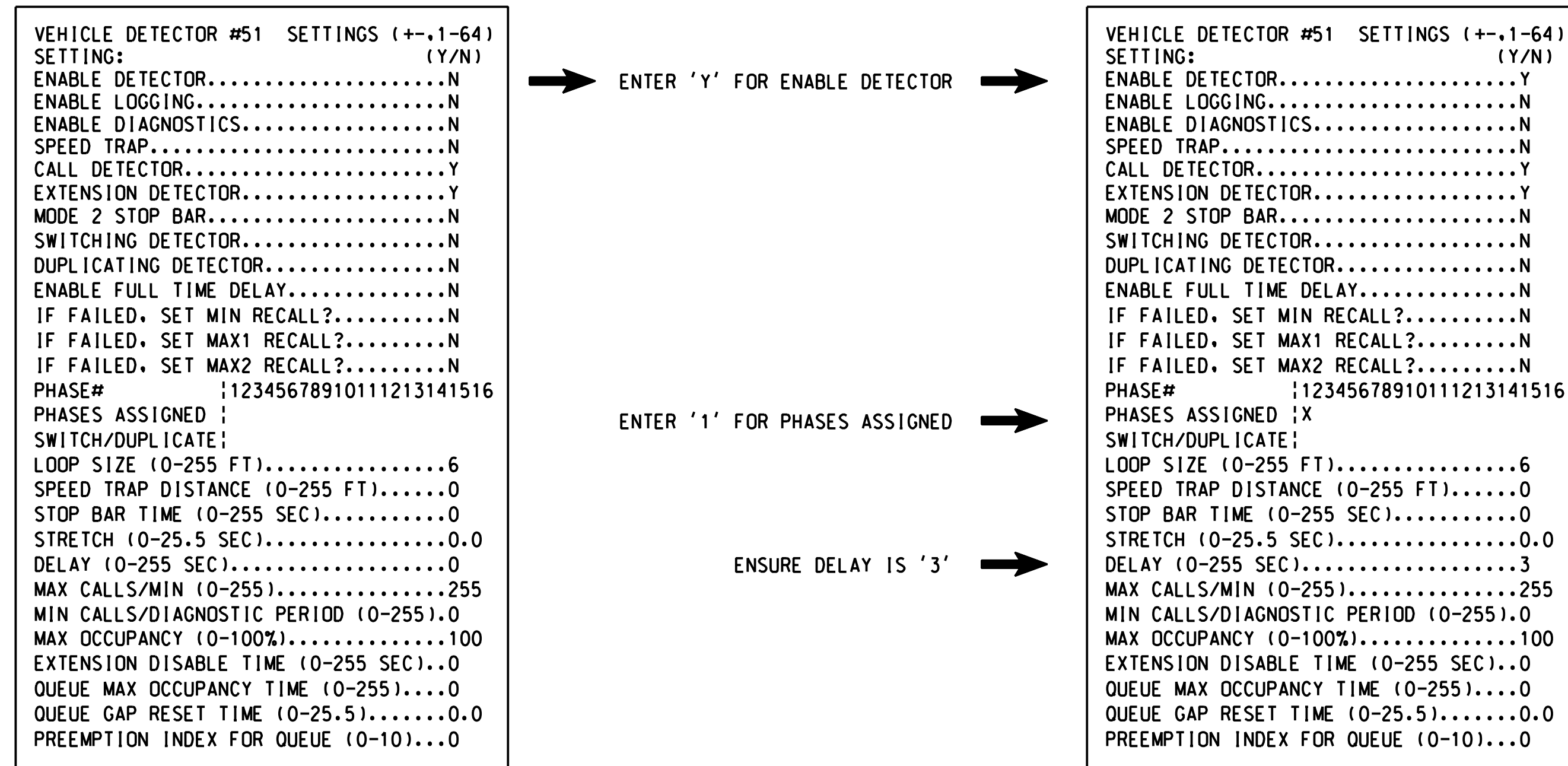

NOTE: DETECTOR IS PROGRAMMED PER THE INPUT FILE CONNECTION AND PROGRAMMING CHART SHOWN ON SHEET 1.

THIS ELECTRICAL DETAIL IS FOR THE SIGNAL DESIGN: 03-0901T2
DESIGNED: June 2017
SEALED: 9/10/2021
REVISED: N/A

DETECTOR PROGRAMMING COMPLETE



HNTB NORTH CAROLINA, P.C.
343 E. Six Forks Road, Suite 200
Raleigh, North Carolina 27609
NC License No: C-1564
(919) 546-8997

Electrical Detail - Sheet 3 of 5
Signal Upgrade
Temporary Design 2

**DOCUMENT NOT CONSIDERED FINAL
UNLESS ALL SIGNATURES COMPLETED**

<p><small>Prepared for:</small></p> <p><small>750 N. Greenfield Pkwy, Corner, NC 27529</small></p>	<p>NC 211 (Southport-Supply Road) at NC 906 (Midway Road/ Middleton Boulevard)</p> <p>Division 03 Brunswick Co. Southport</p> <p>PLAN DATE: June 2017 REVIEWED BY: A.D. Klinksiek</p> <p>PREPARED BY: A.H. Thornburg REVIEWED BY: N.R. Simmons</p>	<p>SEAL</p> <p>9/10/2021</p>						
<table border="1" style="width: 100%; border-collapse: collapse;"> <thead> <tr> <th style="width: 50%;">REVISIONS</th> <th style="width: 25%;">INIT.</th> <th style="width: 25%;">DATE</th> </tr> </thead> <tbody> <tr> <td> </td> <td> </td> <td> </td> </tr> </tbody> </table>			REVISIONS	INIT.	DATE			
REVISIONS	INIT.	DATE						
<p style="text-align: center;"><small>DocuSigned by:</small></p> <p style="text-align: center;">Natasha Simmons</p> <p style="text-align: center;"><small>Signature</small></p>		<p>9/10/2021</p> <p style="text-align: center;"><small>DATE</small></p>						
<p>SIG. INVENTORY NO. 03-0901T2</p>								

INPUT PAGE 2 ASSIGNMENT PROGRAMMING DETAIL FOR ALTERNATE PHASING - LOOP 5A

(program controller as shown below)

- NOTES: 1. THIS PROGRAMMING APPLIES FOR INPUT PAGE 2 ONLY. INPUT PAGE 1 WILL USE STANDARD DEFAULT SETTINGS. THIS PROGRAMMING IS NECESSARY FOR PROPER DETECTOR OPERATION DURING ALTERNATE PHASING OPERATION. 2. THE FIRST TASK THIS PROGRAMMING ACCOMPLISHES IS THE DISABLING OF INPUT #9 (DETECTOR 22) SO THAT A VEHICLE CALL WILL NOT BE PLACED TO PHASE 2 DURING ALTERNATE PHASING OPERATION. THE SECOND TASK THIS PROGRAMMING ACCOMPLISHES IS THAT IT REASSIGNS DETECTOR 55 TO INPUT #17 SO THAT THE DELAY ON LOOP 5A CAN BE REDUCED FROM 15 SECONDS TO 3 SECONDS.

FROM MAIN MENU PRESS '5' (INPUTS), THEN PRESS 'NEXT' TO GET TO INPUT PAGE '2'. PRESS THE '+' KEY UNTIL INPUT 9 IS REACHED.

PAGE: 2 C1 PIN:47 VEHICLE DETECTOR INPUT ASSIGNMENT #.....9 DEBOUNCE TIME (0-25.5 SEC).....0.5 DELAY TIME (0-25.5 SEC).....0.0 HOLD-OVER TIME (0-25.5 SEC).....0.0 ASSIGNMENT SELECTION: NOT ENABLED (Y/N).....Y VEHICLE DETECTOR (1-64).....22 PEDESTRIAN DETECTOR (1-16)..... ALTERNATE PED DETECTOR (1-16)..... PREEMPT (1-10)..... INVERTED PREEMPT (1-10)..... STOP TIME (Y/N)..... FLASH SENSE (Y/N)..... DOOR OPEN (Y/N)..... MANUAL CONTROL ENABLE (Y/N)..... MANUAL CONTROL ADVANCE (Y/N)..... SPECIAL FUNCTION ALARM (1-8)..... TOD HOUR SYNCHRONIZATION (0-23)..... FORCE OFF RING (1-4)..... HOLD PHASES (1-16)..... PLAN (65=FLSH,66=FREE)..... OFFSET#... CHANGE PHASE SEQUENCE PAGE (1-12).... CHANGE PHASE TIMING PAGE (1-4)..... CHANGE PHASE CONTROL PAGE (1-4).... CHANGE OVERLAP CONTROL PAGE (1-4).... CHANGE INPUT PAGE (1-4)..... CHANGE OUTPUT PAGE (1-4)..... OVERRIDE PHASE CONTROL FUNCTION (Y)...

ENTER A 'Y' FOR NOT ENABLED
DEFAULT DETECTOR NUMBER WILL REMAIN UNTIL 'NOT ENABLED' IS ENTERED.

(LOOP 5A - PHASE 2)

PAGE: 2 C1 PIN:47 NOT ENABLED INPUT ASSIGNMENT #.....9 DEBOUNCE TIME (0-25.5 SEC).....0.5 DELAY TIME (0-25.5 SEC).....0.0 HOLD-OVER TIME (0-25.5 SEC).....0.0 ASSIGNMENT SELECTION: NOT ENABLED (Y/N).....Y VEHICLE DETECTOR (1-64)..... PEDESTRIAN DETECTOR (1-16)..... ALTERNATE PED DETECTOR (1-16)..... PREEMPT (1-10)..... INVERTED PREEMPT (1-10)..... STOP TIME (Y/N)..... FLASH SENSE (Y/N)..... DOOR OPEN (Y/N)..... MANUAL CONTROL ENABLE (Y/N)..... MANUAL CONTROL ADVANCE (Y/N)..... SPECIAL FUNCTION ALARM (1-8)..... TOD HOUR SYNCHRONIZATION (0-23)..... FORCE OFF RING (1-4)..... HOLD PHASES (1-16)..... PLAN (65=FLSH,66=FREE)..... OFFSET#... CHANGE PHASE SEQUENCE PAGE (1-12).... CHANGE PHASE TIMING PAGE (1-4)..... CHANGE PHASE CONTROL PAGE (1-4).... CHANGE OVERLAP CONTROL PAGE (1-4).... CHANGE INPUT PAGE (1-4)..... CHANGE OUTPUT PAGE (1-4)..... OVERRIDE PHASE CONTROL FUNCTION (Y)...

PRESS '+' TO ADVANCE TO INPUT 17

PAGE: 2 C1 PIN:55 VEHICLE DETECTOR INPUT ASSIGNMENT #.....17 DEBOUNCE TIME (0-25.5 SEC).....0.5 DELAY TIME (0-25.5 SEC).....0.0 HOLD-OVER TIME (0-25.5 SEC).....0.0 ASSIGNMENT SELECTION: NOT ENABLED (Y/N)..... VEHICLE DETECTOR (1-64).....5 PEDESTRIAN DETECTOR (1-16)..... ALTERNATE PED DETECTOR (1-16)..... PREEMPT (1-10)..... INVERTED PREEMPT (1-10)..... STOP TIME (Y/N)..... FLASH SENSE (Y/N)..... DOOR OPEN (Y/N)..... MANUAL CONTROL ENABLE (Y/N)..... MANUAL CONTROL ADVANCE (Y/N)..... SPECIAL FUNCTION ALARM (1-8)..... TOD HOUR SYNCHRONIZATION (0-23)..... FORCE OFF RING (1-4)..... HOLD PHASES (1-16)..... PLAN (65=FLSH,66=FREE)..... OFFSET#... CHANGE PHASE SEQUENCE PAGE (1-12).... CHANGE PHASE TIMING PAGE (1-4)..... CHANGE PHASE CONTROL PAGE (1-4).... CHANGE OVERLAP CONTROL PAGE (1-4).... CHANGE INPUT PAGE (1-4)..... CHANGE OUTPUT PAGE (1-4)..... OVERRIDE PHASE CONTROL FUNCTION (Y)...

ENTER '55' TO REASSIGN THE VEHICLE DETECTOR FOR THIS INPUT

(LOOP 5A - PHASE 5)

PAGE: 2 C1 PIN:55 VEHICLE DETECTOR INPUT ASSIGNMENT #.....17 DEBOUNCE TIME (0-25.5 SEC).....0.5 DELAY TIME (0-25.5 SEC).....0.0 HOLD-OVER TIME (0-25.5 SEC).....0.0 ASSIGNMENT SELECTION: NOT ENABLED (Y/N)..... VEHICLE DETECTOR (1-64).....55 PEDESTRIAN DETECTOR (1-16)..... ALTERNATE PED DETECTOR (1-16)..... PREEMPT (1-10)..... INVERTED PREEMPT (1-10)..... STOP TIME (Y/N)..... FLASH SENSE (Y/N)..... DOOR OPEN (Y/N)..... MANUAL CONTROL ENABLE (Y/N)..... MANUAL CONTROL ADVANCE (Y/N)..... SPECIAL FUNCTION ALARM (1-8)..... TOD HOUR SYNCHRONIZATION (0-23)..... FORCE OFF RING (1-4)..... HOLD PHASES (1-16)..... PLAN (65=FLSH,66=FREE)..... OFFSET#... CHANGE PHASE SEQUENCE PAGE (1-12).... CHANGE PHASE TIMING PAGE (1-4)..... CHANGE PHASE CONTROL PAGE (1-4).... CHANGE OVERLAP CONTROL PAGE (1-4).... CHANGE INPUT PAGE (1-4)..... CHANGE OUTPUT PAGE (1-4)..... OVERRIDE PHASE CONTROL FUNCTION (Y)...

PROGRAMMING COMPLETE

SPECIAL DETECTOR PROGRAMMING DETAIL - LOOP 5A (ALT.)

(program controller as shown below)

FROM MAIN MENU PRESS '7' (DETECTORS), THEN PRESS '1' FOR VEHICLE DETECTORS. PRESS THE '-' KEY TO GET TO VEHICLE DETECTOR #55.

VEHICLE DETECTOR #55 SETTINGS (+,-,1-64) SETTING: (Y/N) ENABLE DETECTOR.....N ENABLE LOGGING.....N ENABLE DIAGNOSTICS.....N SPEED TRAP.....N CALL DETECTOR.....Y EXTENSION DETECTOR.....Y MODE 2 STOP BAR.....N SWITCHING DETECTOR.....N DUPLICATING DETECTOR.....N ENABLE FULL TIME DELAY.....N IF FAILED, SET MIN RECALL?.....N IF FAILED, SET MAX1 RECALL?.....N IF FAILED, SET MAX2 RECALL?.....N PHASE# :12345678910111213141516 PHASES ASSIGNED : SWITCH/DUPLICATE: LOOP SIZE (0-255 FT).....6 SPEED TRAP DISTANCE (0-255 FT).....0 STOP BAR TIME (0-255 SEC).....0 STRETCH (0-25.5 SEC).....0.0 DELAY (0-255 SEC).....0 MAX CALLS/MIN (0-255).....255 MIN CALLS/DIAGNOSTIC PERIOD (0-255).....0 MAX OCCUPANCY (0-100%).....100 EXTENSION DISABLE TIME (0-255 SEC).....0 QUEUE MAX OCCUPANCY TIME (0-255).....0 QUEUE GAP RESET TIME (0-25.5).....0.0 PREEMPTION INDEX FOR QUEUE (0-10).....0

ENTER 'Y' FOR ENABLE DETECTOR

ENTER '5' FOR PHASES ASSIGNED

ENSURE DELAY IS '3'

VEHICLE DETECTOR #55 SETTINGS (+,-,1-64) SETTING: (Y/N) ENABLE DETECTOR.....Y ENABLE LOGGING.....N ENABLE DIAGNOSTICS.....N SPEED TRAP.....N CALL DETECTOR.....Y EXTENSION DETECTOR.....Y MODE 2 STOP BAR.....N SWITCHING DETECTOR.....N DUPLICATING DETECTOR.....N ENABLE FULL TIME DELAY.....N IF FAILED, SET MIN RECALL?.....N IF FAILED, SET MAX1 RECALL?.....N IF FAILED, SET MAX2 RECALL?.....N PHASE# :12345678910111213141516 PHASES ASSIGNED : X SWITCH/DUPLICATE: LOOP SIZE (0-255 FT).....6 SPEED TRAP DISTANCE (0-255 FT).....0 STOP BAR TIME (0-255 SEC).....0 STRETCH (0-25.5 SEC).....0.0 DELAY (0-255 SEC).....3 MAX CALLS/MIN (0-255).....255 MIN CALLS/DIAGNOSTIC PERIOD (0-255).....0 MAX OCCUPANCY (0-100%).....100 EXTENSION DISABLE TIME (0-255 SEC).....0 QUEUE MAX OCCUPANCY TIME (0-255).....0 QUEUE GAP RESET TIME (0-25.5).....0.0 PREEMPTION INDEX FOR QUEUE (0-10).....0

DETECTOR PROGRAMMING COMPLETE

NOTE: DETECTOR IS PROGRAMMED PER THE INPUT FILE CONNECTION AND PROGRAMMING CHART SHOWN ON SHEET 1.

THIS ELECTRICAL DETAIL IS FOR THE SIGNAL DESIGN: 03-0901T2 DESIGNED: June 2017 SEALED: 9/10/2021 REVISED: N/A

Electrical Detail - Sheet 4 of 5
Signal Upgrade
Temporary Design 2

DOCUMENT NOT CONSIDERED FINAL UNLESS ALL SIGNATURES COMPLETED

Table with project details: NC 211 (Southport-Supply Road) at NC 906 (Midway Road/Middleton Boulevard), Division 03 Brunswick Co. Southport. Includes dates (June 2017, 9/10/2021), signatures (A.H. Thornburg, N.R. Simmons, Natasha Simmons), and a professional seal for Natasha R. Simmons, Engineer, No. 031464.

ALTERNATE PHASING ACTIVATION DETAIL

TO RUN ALT. PHASING DURING COORDINATION - SELECT ALL PAGE CHANGES (AS SHOWN BELOW) WITHIN COORDINATION PLAN PROGRAMMING.

TO RUN ALT. PHASING DURING FREE RUN - PROGRAM PAGE CHANGES (SHOWN BELOW) IN SEPARATE TIME OF DAY EVENTS. IF PAGE 1 IS USED, NO EVENT PROGRAMMING IS NECESSARY FOR THAT PARTICULAR PAGE.

<u>PHASING</u>	<u>INPUTS PAGE</u>	<u>OVERLAPS PAGE</u>
ACTIVE PAGES REQUIRED TO RUN <u>DEFAULT PHASING</u>	1	1
ACTIVE PAGES REQUIRED TO RUN <u>ALTERNATE PHASING</u>	2	2

NOTE: PAGES NOT SHOWN (i.e. sequence, phase control, etc.) SHOULD REMAIN AS '1', OR AS DEFINED BY TIMING ENGINEER.

IMPORTANT: IF ALT. PHASING IS USED DURING FREE RUN AND COORDINATION, DO NOT OPERATE TIME OF DAY PAGE CHANGE EVENTS CONCURRENTLY WITH COORDINATION PLAN EVENTS IN THE EVENT SCHEDULER. (EX. FREE RUN PAGE CHANGE EVENT SHOULD END BEFORE COORDINATION PLAN EVENT STARTS AND VICE-VERSA).

ALTERNATE PHASING PAGE CHANGE SUMMARY

THE FOLLOWING IS A SUMMARY OF WHAT TAKES PLACE WHEN THESE OVERLAP/INPUT PAGE CHANGES ACTIVATE TO CALL THE "ALTERNATE PHASING":

OVERLAPS PAGE 2: Modifies overlap parent phases for heads 11 and 51 to run protected turns only.

INPUTS PAGE 2: Disables phase 6 call on loop 1A and reduces delay time for phase 1 call on loop 1A to 3 seconds.

Disables phase 2 call on loop 5A and reduces delay time for phase 5 call on loop 5A to 3 seconds.

THIS ELECTRICAL DETAIL IS FOR
THE SIGNAL DESIGN: 03-0901T2
DESIGNED: June 2017
SEALED: 9/10/2021
REVISED: N/A

Electrical Detail - Sheet 5 of 5
Signal Upgrade
Temporary Design 2

**DOCUMENT NOT CONSIDERED FINAL
UNLESS ALL SIGNATURES COMPLETED**

HNTB HNTB NORTH CAROLINA, P.C.
343 E. Six Forks Road, Suite 200
Raleigh, North Carolina 27609
NC License No: C-1554
(919) 546-8997

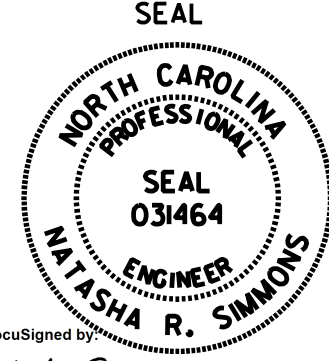
<p style="font-size: small;">ELECTRICAL AND PROGRAMMING DETAILS FOR:</p> <p style="text-align: center;">Prepared for:  750 N. Greenfield Pkwy, Corner, NC 27529</p>	<p>NC 211 (Southport-Supply Road) at NC 906 (Midway Road/ Middleton Boulevard)</p> <p style="font-size: x-small;">Division 03 Brunswick Co. Southport</p> <p style="font-size: x-small;">PLAN DATE: June 2017 REVIEWED BY: A.D. Klinksiek</p> <p style="font-size: x-small;">PREPARED BY: A.H. Thornburg REVIEWED BY: N.R. Simmons</p>	<p style="text-align: center;">SEAL</p> <p style="text-align: center;"></p> <p style="font-size: x-small;">DocuSigned by: Natasha Simmons 9/10/2021</p>												
<table border="1" style="width: 100%; border-collapse: collapse;"> <thead> <tr> <th style="font-size: x-small;">REVISIONS</th> <th style="font-size: x-small;">INIT.</th> <th style="font-size: x-small;">DATE</th> </tr> </thead> <tbody> <tr> <td> </td> <td> </td> <td> </td> </tr> <tr> <td> </td> <td> </td> <td> </td> </tr> <tr> <td> </td> <td> </td> <td> </td> </tr> </tbody> </table>		REVISIONS	INIT.	DATE										<p style="font-size: x-small;">SIGNATURE DATE</p> <p style="font-size: x-small;">SIG. INVENTORY NO. 03-0901T2</p>
REVISIONS	INIT.	DATE												

DEFAULT PHASING DIAGRAM

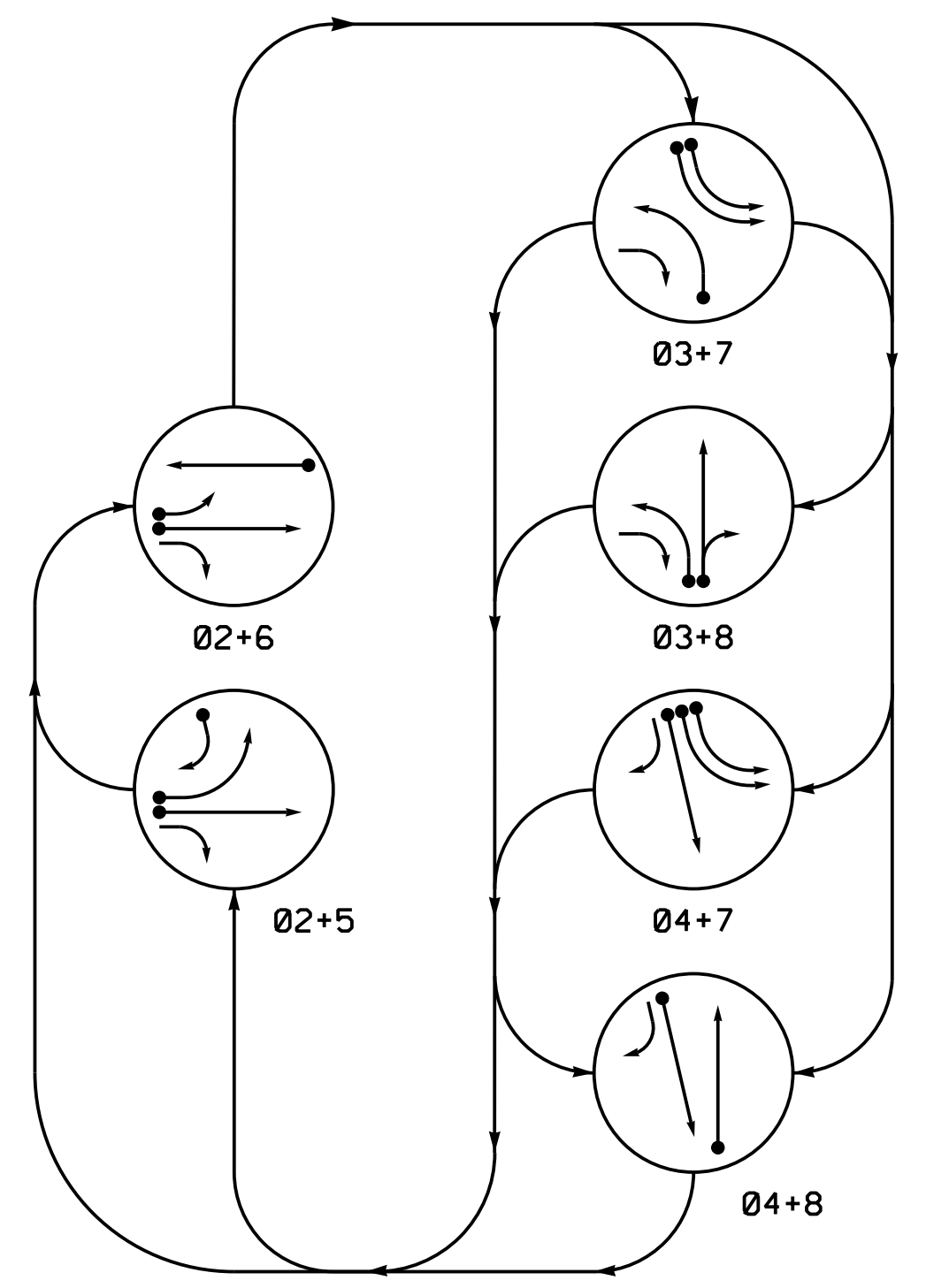

DEFAULT PHASING TABLE OF OPERATION

SIGNAL FACE	PHASE							
	02+5	02+6	03+7	03+8	04+7	04+8	F	Y
21	G	G	R	R	R	R	Y	
22	G	G	R	R	R	R	Y	
31	R	R					R	R
41	R	R	R	R	G	G	R	
42	R	R	R	R	G	G	R	
51			R	R	R	R	Y	
61,62,63	R	G	R	R	R	R	Y	
71,72	R	R					R	R
81,82	R	R	R	G	R	G	R	

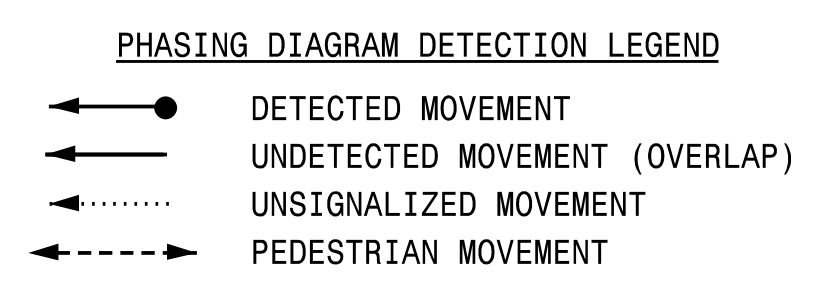

SIGNAL FACE I.D.

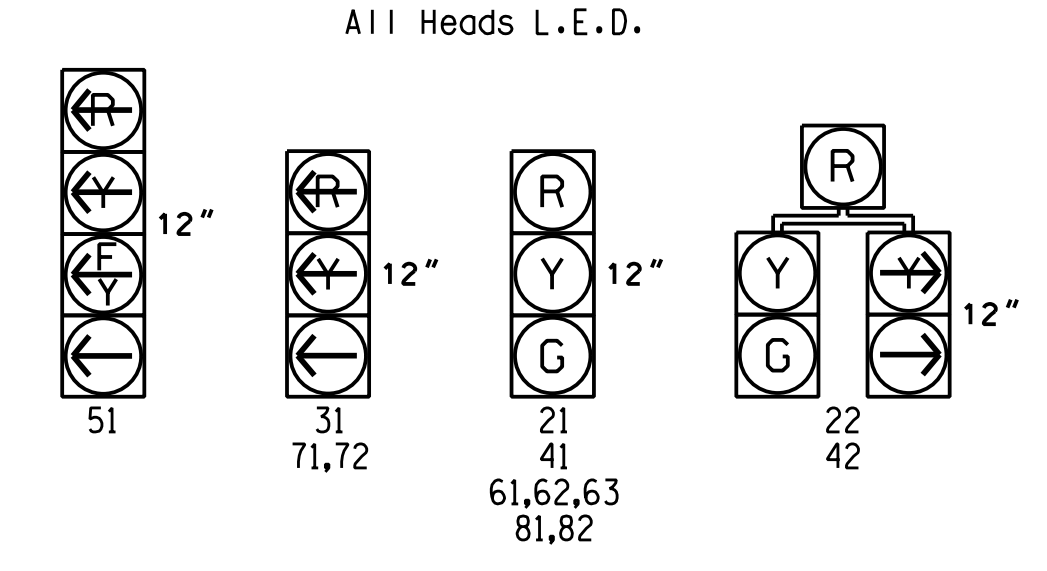

OASIS 2070 LOOP & DETECTOR INSTALLATION CHART

LOOP	SIZE (FT)	DISTANCE FROM STOPBAR (FT)	TURNS	DETECTOR PROGRAMMING								
				NEW LOOP	PHASE	CALLING	EXTENSION	FULL TIME DELAY	STRETCH TIME	DELAY TIME	SYSTEM LOOP	NEW CARD
2A	6X6	420	*	*	2	Y	Y	-	-	-	-	-
3A	6X40	0	*	*	3	Y	Y	-	-	-	-	-
4A	6X6	300	*	*	4	-	Y	-	-	-	-	-
4B	6X40	0	*	*	4	Y	Y	Y	2.0	5	-	-
5A	6X40	0	*	*	5	Y	Y	-	-	***15	-	-
5B	6X40	0	*	*	**2	Y	Y	Y	-	3	-	-
6A	6X6	420	*	*	6	Y	Y	-	-	-	-	-
7A	6X40	0	*	*	7	Y	Y	-	-	3	-	-
7B	6X40	0	*	*	7	Y	Y	-	-	-	-	-
8A	6X6	420	*	*	8	-	Y	-	-	-	-	-
8B	6X40	0	*	*	8	Y	Y	Y	2.0	5	-	-

* Multizone Microwave Detection.
 ** Disable phase 2 call for 5A during alternate phasing operation.
 *** Reduce delay to 3 seconds during alternate phasing operation.

6 Phase Fully Actuated Isolated

- NOTES**
- Refer to "Roadway Standard Drawings NCDOT" dated January 2018 and "Standard Specifications for Roads and Structures" dated January 2018.
 - Do not program signal for late night flashing operation unless otherwise directed by the Engineer.
 - Program controller to clear from phase 2+6 to phase 2+5 by progressing through phase 4+8 (see Electrical Details).
 - Phase 3 and/or phase 7 may be lagged.
 - Reposition existing signal head numbered 61.
 - Set all detector units to presence mode.
 - The Division Traffic Engineer will determine the hours of use for each phasing plan.
 - Incorporate Microwave Detection system for vehicle detection.
 - Provide the Engineer with the Manufacturer's approved Microwave Detection locations and mounting heights to obtain detection zones as shown.

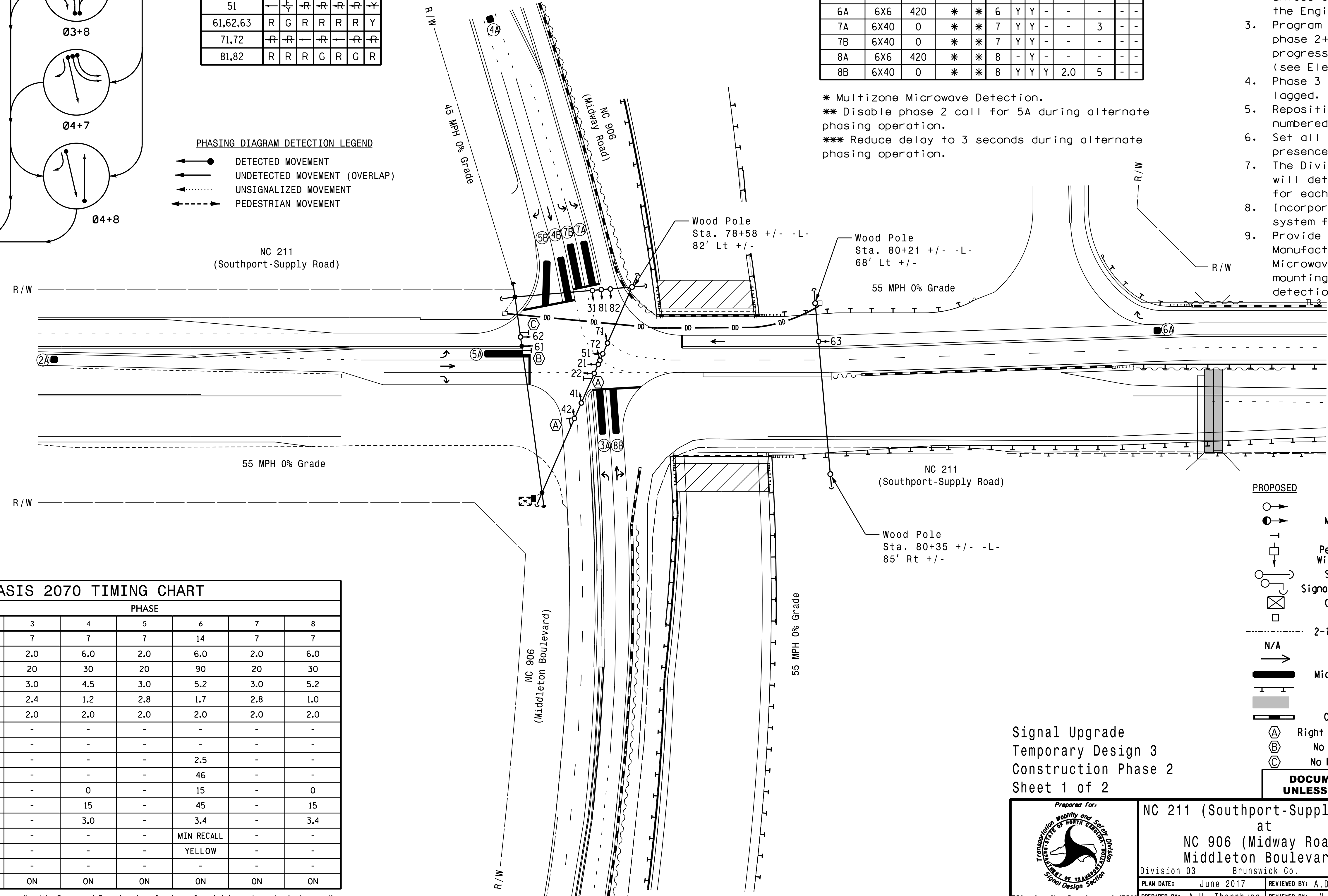

OASIS 2070 TIMING CHART

FEATURE	PHASE							
	2	3	4	5	6	7	8	
Min Green 1 *	14	7	7	7	14	7	7	
Extension 1 *	6.0	2.0	6.0	2.0	6.0	2.0	6.0	
Max Green 1 *	90	20	30	20	90	20	30	
Yellow Clearance	5.2	3.0	4.5	3.0	5.2	3.0	5.2	
Red Clearance	1.7	2.4	1.2	2.8	1.7	2.8	1.0	
Red Revert	2.0	2.0	2.0	2.0	2.0	2.0	2.0	
Walk 1 *	-	-	-	-	-	-	-	
Don't Walk 1	-	-	-	-	-	-	-	
Seconds Per Actuation *	2.5	-	-	-	2.5	-	-	
Max Variable Initial *	46	-	-	-	46	-	-	
Time Before Reduction *	15	-	0	-	15	-	0	
Time To Reduce *	45	-	15	-	45	-	15	
Minimum Gap	3.4	-	3.0	-	3.4	-	3.4	
Recall Mode	MIN RECALL	-	-	-	MIN RECALL	-	-	
Vehicle Call Memory	YELLOW	-	-	-	YELLOW	-	-	
Dual Entry	-	-	-	-	-	-	-	
Simultaneous Gap	ON	ON	ON	ON	ON	ON	ON	

* These values may be field adjusted. Do not adjust Min Green and Extension times for phases 2 and 6 lower than what is shown. Min Green for all other phases should not be lower than 4 seconds.

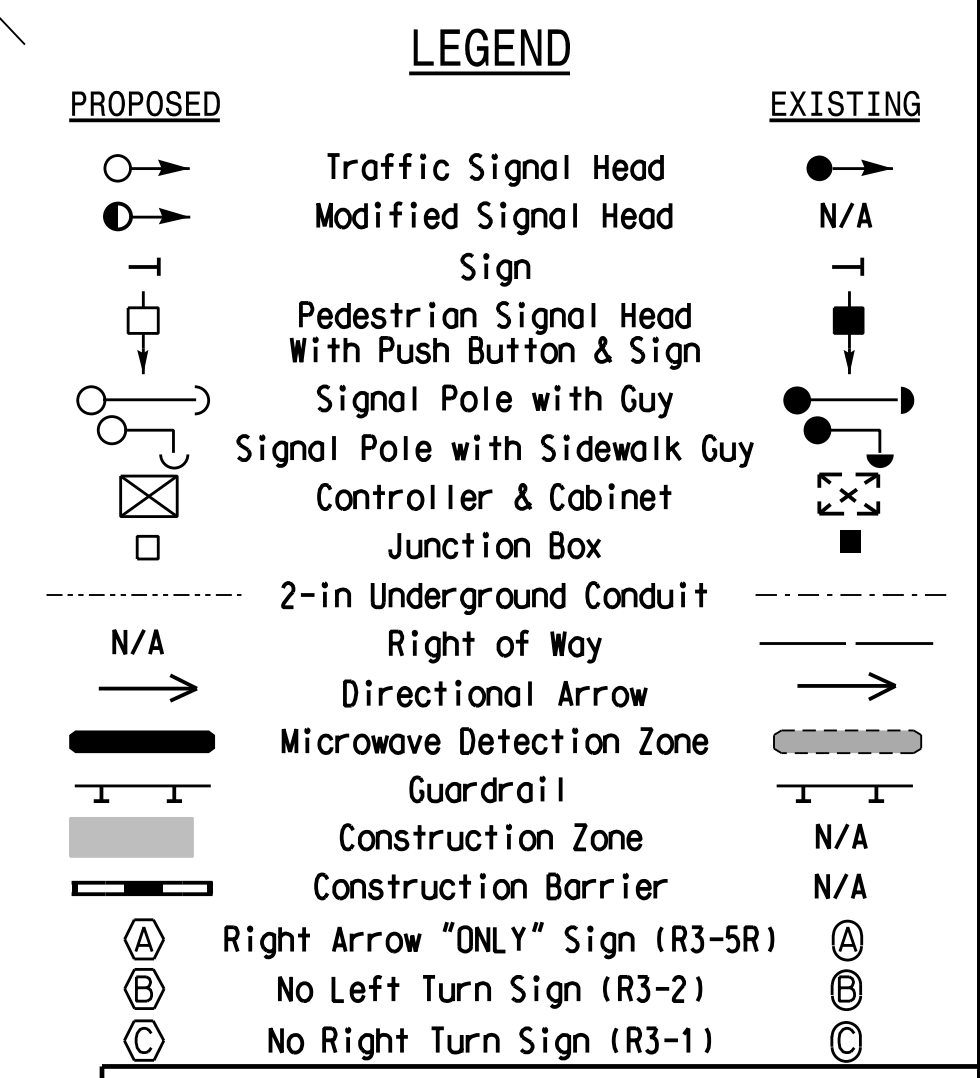

DOCUMENT NOT CONSIDERED FINAL UNLESS ALL SIGNATURES COMPLETED

Signal Upgrade
 Temporary Design 3
 Construction Phase 2
 Sheet 1 of 2

<p>HNTB NORTH CAROLINA, P.C. 343 E. Six Forks Road, Suite 200 Raleigh, North Carolina 27609 NC License No: C-1554 (919) 546-8997</p>	NC 211 (Southport-Supply Road) at NC 906 (Middleton Road/ Brunswick Co. Southport Division 03 PLAN DATE: June 2017 PREPARED BY: A.H. Thornburg REVISIONS: _____ SCALE: 1"=50' NORTH ARROW	SEAL SEAL 031464 ENGINEER NATASHA R. SIMMONS REVIEWED BY: A.D. Klinksiek REVIEWED BY: N.R. Simmons DATE: 9/10/2021 SIGNATURE: _____ DATE: _____ SIG. INVENTORY NO. 03-090173
	DOCUMENT NOT CONSIDERED FINAL UNLESS ALL SIGNATURES COMPLETED	

SIGNAL FACE I.D.

All Heads L.E.D.

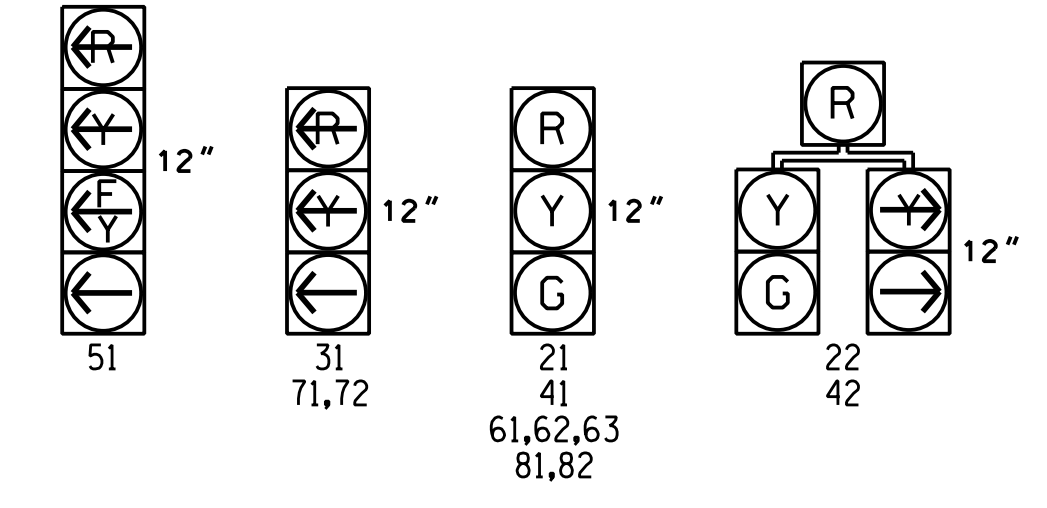

ALTERNATE PHASING DIAGRAM

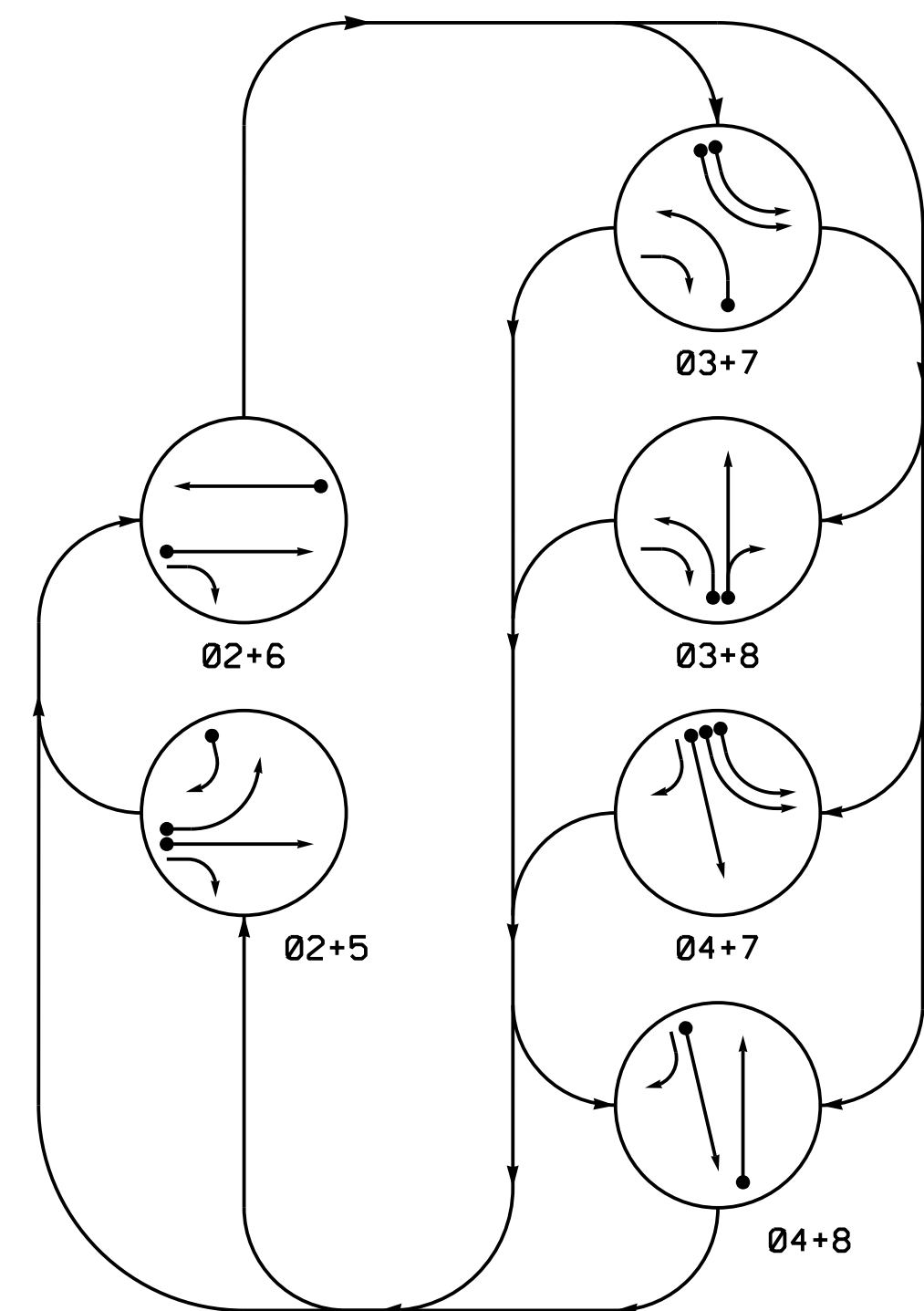

PHASING DIAGRAM DETECTION LEGEND

- ←● DETECTED MOVEMENT
- ← UNDETECTED MOVEMENT (OVERLAP)
- ←..... UNSIGNALIZED MOVEMENT
- ←- - - PEDESTRIAN MOVEMENT

ALTERNATE PHASING TABLE OF OPERATION

SIGNAL FACE	PHASE							
	02+5	02+6	03+7	03+8	04+7	04+8	FLASH	
21	G	G	R	R	R	R	Y	
22	G	G	R	R	R	R	Y	
31	R	R	-	-	R	R	R	
41	R	R	R	R	G	G	R	
42	R	R	R	R	G	G	R	
51	-	R	R	R	R	R	Y	
61,62,63	R	G	R	R	R	R	Y	
71,72	R	R	-	-	R	R		
81,82	R	R	R	G	R	G	R	

Signal Upgrade
 Temporary Design 3
 Construction Phase 2
 Sheet 2 of 2

**DOCUMENT NOT CONSIDERED FINAL
 UNLESS ALL SIGNATURES COMPLETED**

HNTB HNTB NORTH CAROLINA, P.C.
 343 E. Six Forks Road, Suite 200
 Raleigh, North Carolina 27609
 NC License No: C-1554
 (919) 546-8997

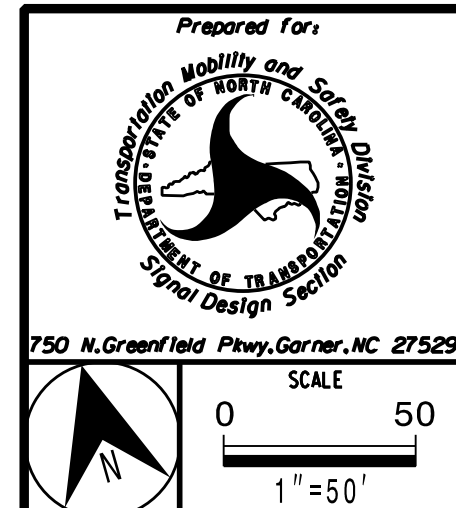

Prepared for:
 NC 211 (Southport-Supply Road)
 at
 NC 906 (Midway Road/
 Middleton Boulevard)
 Division 03 Brunswick Co. Southport
 PLAN DATE: June 2017 REVIEWED BY: A.D. Klinksiek
 PREPARED BY: A.H. Thornburg REVIEWED BY: N.R. Simmons

SEAL
 NORTH CAROLINA
 PROFESSIONAL
 SEAL
 031464
 ENGINEER
 NATASHA R. SIMMONS
 Signature: *Natasha Simmons*
 DATE: 9/10/2021
 SIG. INVENTORY NO. 03-090173

EDI MODEL 2018ECL-NC CONFLICT MONITOR PROGRAMMING DETAIL

(remove jumpers and set switches as shown)

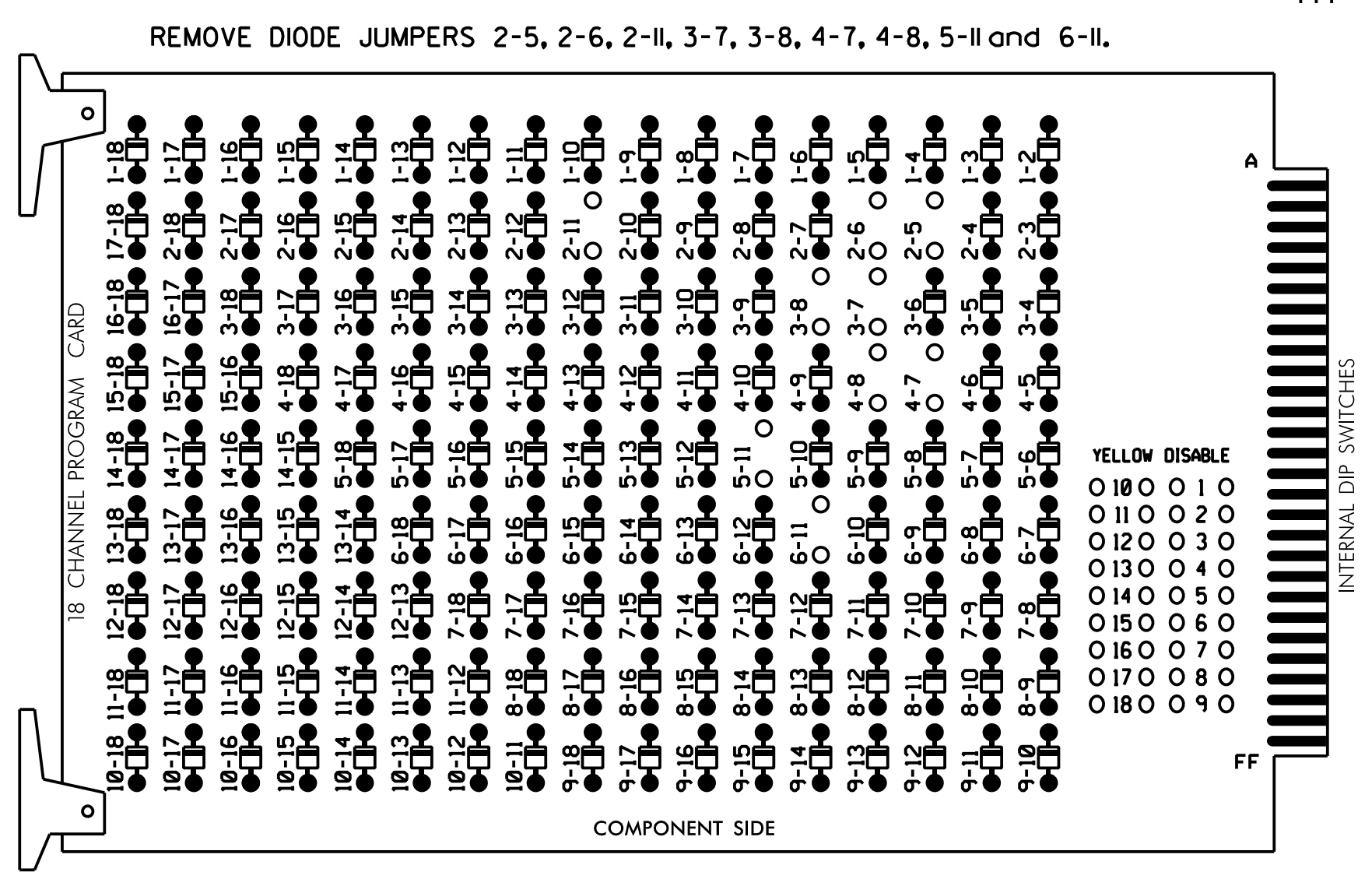

NOTES:

- Card is provided with all diode jumpers in place. Removal of any jumper allows its channels to run concurrently.
- Ensure jumpers SEL2-SEL5 and SEL9 are present on the monitor board.
- Ensure that Red Enable is active at all times during normal operation.
- Connect serial cable from conflict monitor to comm. port 1 of 2070 controller. Ensure conflict monitor communicates with 2070.

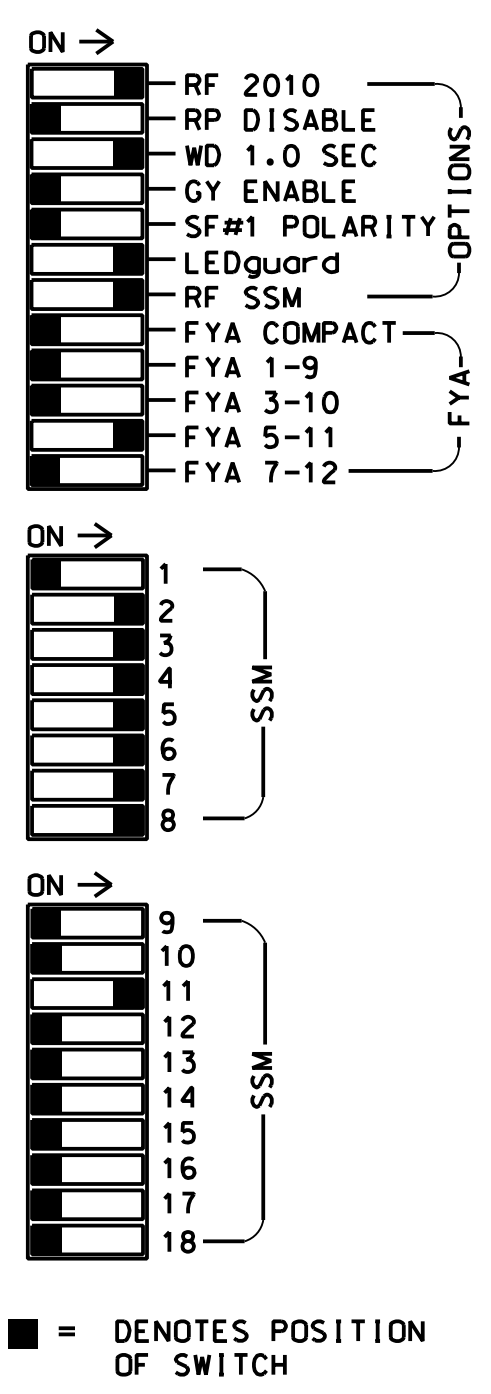

NOTES

- To prevent "flash-conflict" problems, insert red flash program blocks for all unused vehicle load switches in the output file. The installer shall verify that signal heads flash in accordance with the Signal Plans.
- Enable Simultaneous Gap-Out for all Phases.
- Program phases 2 and 6 for Variable Initial and phases 2,4,6 and 8 for Gap Reduction.
- Program phases 2 and 6 for Startup In Green.
- Program phases 2 and 6 for Yellow Flash, and overlap 1 as Wag Overlap.
- If this signal will be managed by an ATMS software, enable controller and detector logging for all detectors used at this location.

EQUIPMENT INFORMATION

CONTROLLER.....2070E
 CABINET.....332 W/ AUX
 SOFTWARE.....ECONOLITE OASIS
 CABINET MOUNT.....BASE
 OUTPUT FILE POSITIONS...18 WITH AUX. OUTPUT FILE
 LOAD SWITCHES USED.....S2,S4,S5,S7,S8,S10,S11,
 AUX S4
 PHASES USED.....2,3,4,5,6,7,8
 OVERLAP "A".....NOT USED
 OVERLAP "B".....NOT USED
 OVERLAP "C".....5+6
 OVERLAP "D".....NOT USED

SIGNAL HEAD HOOK-UP CHART

LOAD SWITCH NO.	S1	S2	S3	S4	S5	S6	S7	S8	S9	S10	S11	S12	AUX S1	AUX S2	AUX S3	AUX S4	AUX S5	AUX S6
CMU CHANNEL NO.	1	2	13	3	4	14	5	6	15	7	8	16	9	10	17	11	12	18
PHASE	1	2	2 PED	3	4	4 PED	5	6	6 PED	7	8	8 PED	OLA	OLB	SPARE	OLC	OLD	SPARE
SIGNAL HEAD NO.	NU	21,22	NU	22	31	41,42	NU	42	51	61,62 63	NU	71,72	81,82	NU	NU	51	NU	NU
RED		128				101		*		134		107						
YELLOW		129				102				135		108						
GREEN		130				103				136		109						
RED ARROW					116							122						A114
YELLOW ARROW				117	117			132				123						A115
FLASHING YELLOW ARROW																		A116
GREEN ARROW					118	118		133	133			124						

NU = Not Used

- * Denotes install load resistor. See load resistor installation detail this sheet.
- * See pictorial of head wiring in detail this sheet.

INPUT FILE POSITION LAYOUT

(front view)

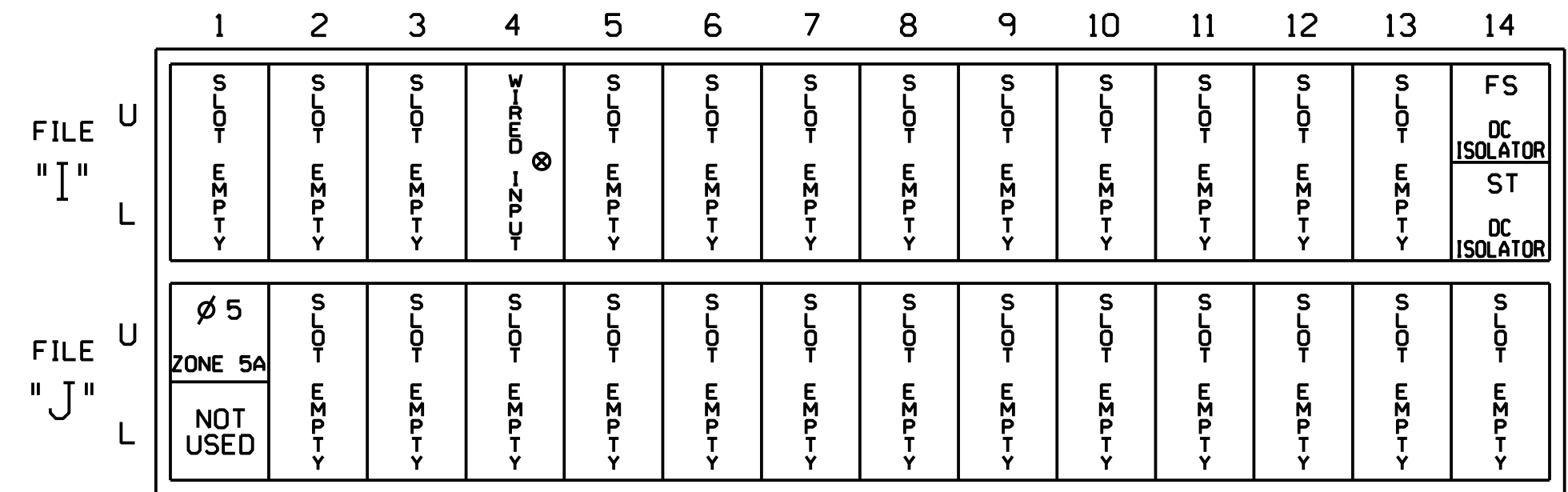

EX.: 1A, 2A, ETC. = LOOP NO.'S

FS = FLASH SENSE
 ST = STOP TIME

⊗ Wired Input - Do not populate slot with detector card

INPUT FILE CONNECTION & PROGRAMMING CHART

LOOP NO.	LOOP TERMINAL	INPUT FILE POS.	PIN NO.	INPUT ASSIGNMENT NO.	DETECTOR NO.	NEMA PHASE	CALL	EXTEND	FULL TIME DELAY	STRETCH TIME	DELAY TIME
ZONE 5A ¹	**	J1U	55	17	5	5	Y	Y			15
	-	14U	47	9*	22	2	Y	Y	Y		3
	-	J1U	55	17*	55	5	Y	Y			3

- ¹Add jumper from J1-W to 14-W, on rear of input file.
- * See Input Page Assignment programming details on sheet 3.
- ** Multizone Microwave Detector Zone. See Special Detector Note.

INPUT FILE POSITION LEGEND: J2L

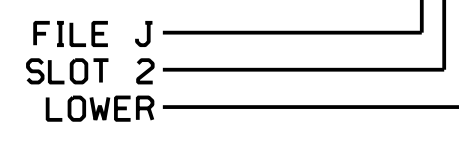

FYA SIGNAL WIRING DETAIL

(wire signal heads as shown)

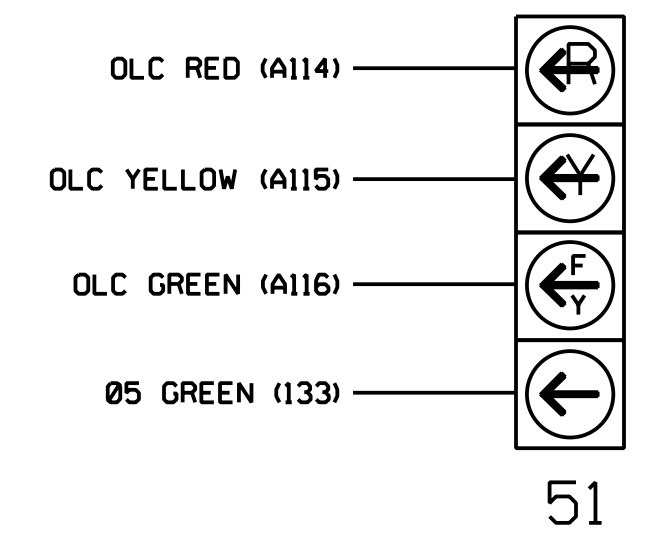

NOTE

The sequence display for signal head 51 requires special logic programming. See sheet 2 for programming instructions.

LOAD RESISTOR INSTALLATION DETAIL

(install resistor as shown)

VALUE (ohms)	WATTAGE
1.5K - 1.9K	25W (min)
2.0K - 3.0K	10W (min)

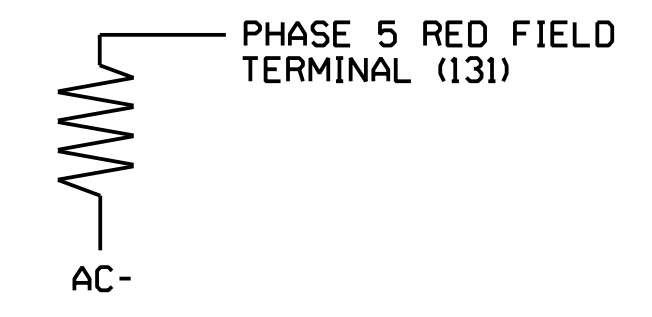

! IMPORTANT: REMOVE RESISTOR FROM PHASE 1 RED FIELD TERMINAL, IF PRESENT.

SPECIAL DETECTOR NOTE

Install a microwave detection system for vehicle detection. Perform installation according to manufacturer's directions and NCDOT engineer-approved mounting locations to accomplish the detection schemes shown on the Signal Design Plans.

For loop 5A detector card placement and slots reserved for wired inputs are typical for a NCDOT installation. Inputs associated with these slots are compatible with the time of day instructions located on sheet 3 and 4 of this electrical detail.

THIS ELECTRICAL DETAIL IS FOR THE SIGNAL DESIGN: 03-0901T3
 DESIGNED: June 2017
 SEALED: 9/10/2021
 REVISED: N/A

Electrical Detail - Sheet 1 of 4
 Signal Upgrade
 Temporary Design 3

DOCUMENT NOT CONSIDERED FINAL UNLESS ALL SIGNATURES COMPLETED

	NC 211 (Southport-Supply Road) at NC 906 (Midway Road/ Middleton Boulevard) Division 03 Brunswick Co. Southport		
	Prepared for: 	PLAN DATE: June 2017 PREPARED BY: A.H. Thornburg	
REVISIONS		INIT.	DATE
Signature: <i>Natasha Simmons</i>		Signature: _____	Date: 9/10/2021
SIG. INVENTORY NO. 03-0901T3			

LOGICAL I/O PROCESSOR PROGRAMMING DETAIL TO PRODUCE SPECIAL FYA-PPLT SIGNAL SEQUENCE

(program controller as shown below)

- FROM MAIN MENU PRESS '2' (PHASE CONTROL), THEN '1' (PHASE CONTROL FUNCTIONS). SCROLL TO THE BOTTOM OF THE MENU AND ENABLE ACT LOGIC COMMANDS 4, 5, AND 6. **! DISABLE ACT LOGIC COMMANDS 1, 2, AND 3. !**
- FROM MAIN MENU PRESS '6' (OUTPUTS), THEN '3' (LOGICAL I/O PROCESSOR).

```

LOGICAL I/O COMMAND #4 (+/-COMMAND#)
IF ACTIVE PHASE #5 IS ON
AND RED CLEAR ON PHASE #5 IS ON

      ↓
    SCROLL DOWN

THEN:
SET OUTPUT ASSIGNMENT #42 ON
SET OUTPUT ASSIGNMENT #43 OFF
  
```

NOTE: LOGIC FOR PHASE 5 RED CLEAR WHEN TRANSITIONING FROM PHASE 5 TO PHASE 6 (HEAD 51).

```

LOGICAL I/O COMMAND #5 (+/-COMMAND#)
IF ACTIVE PHASE #5 IS ON

      ↓
    SCROLL DOWN

THEN:
SET OUTPUT ASSIGNMENT #44 OFF
  
```

NOTE: LOGIC FOR SWITCHING FLASHING YELLOW ARROW OFF DURING PHASE 5 (HEAD 51).

```

LOGICAL I/O COMMAND #6 (+/-COMMAND#)
IF YELLOW ON PHASE #5 IS ON

      ↓
    SCROLL DOWN

THEN:
SET OUTPUT ASSIGNMENT #43 ON
  
```

NOTE: LOGIC FOR YELLOW ARROW CLEARANCE FROM PHASE 5 (HEAD 51).

LOGIC I/O PROCESSOR PROGRAMMING COMPLETE

OUTPUT REFERENCE SCHEDULE	
USE TO INTERPRET LOGIC PROCESSOR	
OUTPUT 42	= Overlap C Red
OUTPUT 43	= Overlap C Yellow
OUTPUT 44	= Overlap C Green

OVERLAP PROGRAMMING DETAIL FOR DEFAULT PHASING

(program controller as shown below)

FROM MAIN MENU PRESS '8' (OVERLAPS), THEN '1' (VEHICLE OVERLAP SETTINGS).

PRESS '+' TWICE

```

PAGE 1: VEHICLE OVERLAP 'C' SETTINGS
PHASE:      :12345678910111213141516
VEH OVL PARENTS:  XX
VEH OVL NOT VEH:
VEH OVL NOT PED:
VEH OVL GRN EXT:
STARTUP COLOR:  - RED - YELLOW - GREEN
FLASH COLORS:  - RED - YELLOW X GREEN
SELECT VEHICLE OVERLAP OPTIONS: (Y/N)
FLASH YELLOW IN CONTROLLER FLASH?...Y
GREEN EXTENSION (0-255 SEC)...0.0
YELLOW CLEAR (0=PARENT,3-25.5 SEC)...0.0
RED CLEAR (0=PARENT,0.1-25.5 SEC)...0.0
OUTPUT AS PHASE # (0=NONE, 1-16)...0
  
```

← NOTICE GREEN FLASH

OVERLAP PROGRAMMING COMPLETE

OVERLAP PROGRAMMING DETAIL FOR ALTERNATE PHASING

(program controller as shown below)

FROM MAIN MENU PRESS '8' (OVERLAPS), THEN '1' (VEHICLE OVERLAP SETTINGS). PRESS 'NEXT' TO ADVANCE TO PAGE 2.

PRESS '+' TWICE

NOTICE PAGE 2 →

```



PAGE 2: VEHICLE OVERLAP 'C' SETTINGS
PHASE:      :12345678910111213141516
VEH OVL PARENTS:  X
VEH OVL NOT VEH:
VEH OVL NOT PED:
VEH OVL GRN EXT:
STARTUP COLOR:  - RED - YELLOW - GREEN
FLASH COLORS:  - RED - YELLOW - GREEN
SELECT VEHICLE OVERLAP OPTIONS: (Y/N)
FLASH YELLOW IN CONTROLLER FLASH?...Y
GREEN EXTENSION (0-255 SEC)...0.0
YELLOW CLEAR (0=PARENT,3-25.5 SEC)...0.0
RED CLEAR (0=PARENT,0.1-25.5 SEC)...0.0
OUTPUT AS PHASE # (0=NONE, 1-16)...0
  
```

OVERLAP PROGRAMMING COMPLETE

THIS ELECTRICAL DETAIL IS FOR THE SIGNAL DESIGN: 03-0901T3
 DESIGNED: June 2017
 SEALED: 9/10/2021
 REVISED: N/A

Electrical Detail - Sheet 2 of 4
Signal Upgrade
Temporary Design 3

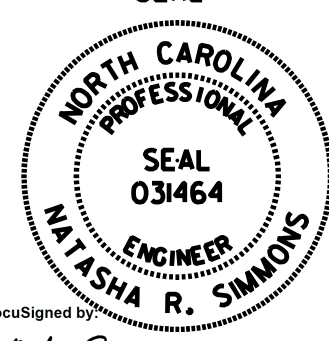
DOCUMENT NOT CONSIDERED FINAL UNLESS ALL SIGNATURES COMPLETED

	Prepared for: NC 211 (Southport-Supply Road) at NC 906 (Midway Road/Middleton Boulevard) Division 03 Brunswick Co. Southport		
	PLAN DATE: June 2017 PREPARED BY: A.H. Thornburg	REVIEWED BY: A.D. Klinksiek REVIEWED BY: N.R. Simmons	
 HNTB NORTH CAROLINA, P.C. 343 E. Six Forks Road, Suite 200 Raleigh, North Carolina 27609 NC License No: C-1554 (919) 546-8997		Documented by:  9/10/2021 SIG. INVENTORY NO. 03-0901T3	

INPUT PAGE 2 ASSIGNMENT PROGRAMMING DETAIL FOR ALTERNATE PHASING - LOOP 5A

(program controller as shown below)

- NOTES: 1. THIS PROGRAMMING APPLIES FOR INPUT PAGE 2 ONLY. INPUT PAGE 1 WILL USE STANDARD DEFAULT SETTINGS. THIS PROGRAMMING IS NECESSARY FOR PROPER DETECTOR OPERATION DURING ALTERNATE PHASING OPERATION.
2. THE FIRST TASK THIS PROGRAMMING ACCOMPLISHES IS THE DISABLING OF INPUT #9 (DETECTOR 22) SO THAT A VEHICLE CALL WILL NOT BE PLACED TO PHASE 2 DURING ALTERNATE PHASING OPERATION. THE SECOND TASK THIS PROGRAMMING ACCOMPLISHES IS THAT IT REASSIGNS DETECTOR 55 TO INPUT #17 SO THAT THE DELAY ON LOOP 5A CAN BE REDUCED FROM 15 SECONDS TO 3 SECONDS.

FROM MAIN MENU PRESS '5' (INPUTS), THEN PRESS 'NEXT' TO GET TO INPUT PAGE '2'. PRESS THE '+' KEY UNTIL INPUT 9 IS REACHED.

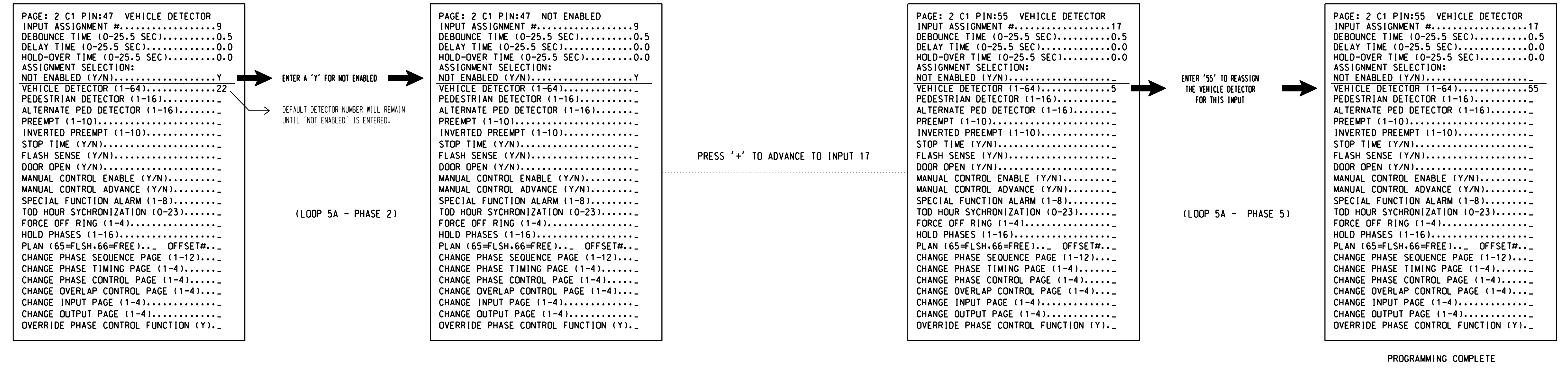

SPECIAL DETECTOR PROGRAMMING DETAIL - LOOP 5A (ALT.)

(program controller as shown below)

FROM MAIN MENU PRESS '7' (DETECTORS), THEN PRESS '1' FOR VEHICLE DETECTORS. PRESS THE '-' KEY TO GET TO VEHICLE DETECTOR #55.

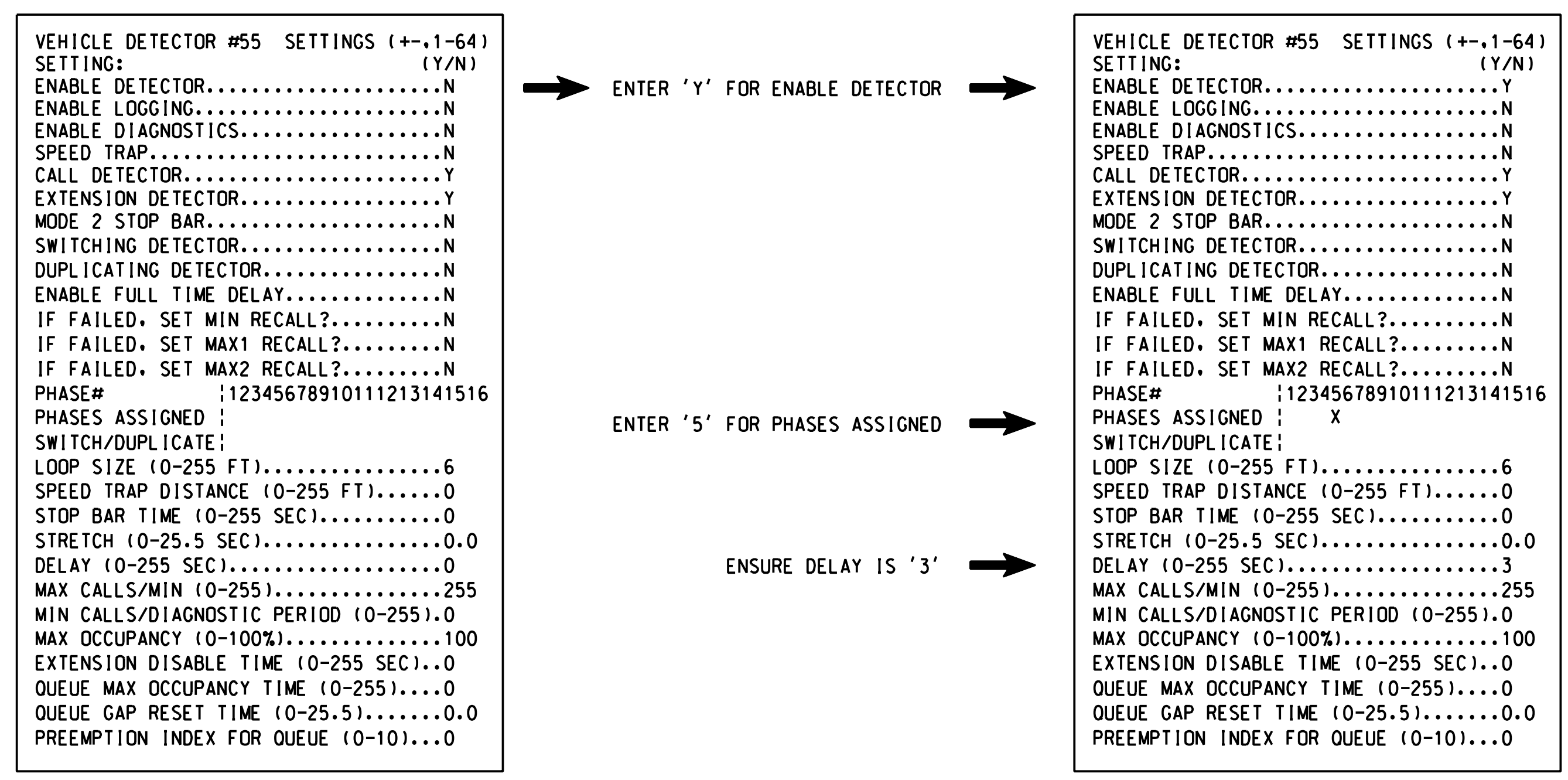

NOTE: DETECTOR IS PROGRAMMED PER THE INPUT FILE CONNECTION AND PROGRAMMING CHART SHOWN ON SHEET 1.

THIS ELECTRICAL DETAIL IS FOR THE SIGNAL DESIGN: 03-0901T3
DESIGNED: June 2017
SEALED: 9/10/2021
REVISED: N/A

Electrical Detail - Sheet 3 of 4
Signal Upgrade
Temporary Design 3

DOCUMENT NOT CONSIDERED FINAL UNLESS ALL SIGNATURES COMPLETED

	NC 211 (Southport-Supply Road) at NC 906 (Midway Road/ Middleton Boulevard)		
	Division 03 Brunswick Co. Southport	PLAN DATE: June 2017 PREPARED BY: A.H. Thornburg	
Prepared for: 	REVISIONS INIT. DATE	DATE SIGNATURE	SEAL NORTH CAROLINA PROFESSIONAL ENGINEER SEAL 031464 NATASHA R. SIMMONS 9/10/2021

ALTERNATE PHASING ACTIVATION DETAIL

TO RUN ALT. PHASING DURING COORDINATION - SELECT ALL PAGE CHANGES (AS SHOWN BELOW) WITHIN COORDINATION PLAN PROGRAMMING.

TO RUN ALT. PHASING DURING FREE RUN - PROGRAM PAGE CHANGES (SHOWN BELOW) IN SEPARATE TIME OF DAY EVENTS. IF PAGE 1 IS USED, NO EVENT PROGRAMMING IS NECESSARY FOR THAT PARTICULAR PAGE.

<u>PHASING</u>	<u>INPUTS PAGE</u>	<u>OVERLAPS PAGE</u>
ACTIVE PAGES REQUIRED TO RUN <u>DEFAULT PHASING</u>	1	1
ACTIVE PAGES REQUIRED TO RUN <u>ALTERNATE PHASING</u>	2	2

NOTE: PAGES NOT SHOWN (i.e. sequence, phase control, etc.) SHOULD REMAIN AS '1', OR AS DEFINED BY TIMING ENGINEER.

IMPORTANT: IF ALT. PHASING IS USED DURING FREE RUN AND COORDINATION, DO NOT OPERATE TIME OF DAY PAGE CHANGE EVENTS CONCURRENTLY WITH COORDINATION PLAN EVENTS IN THE EVENT SCHEDULER. (EX. FREE RUN PAGE CHANGE EVENT SHOULD END BEFORE COORDINATION PLAN EVENT STARTS AND VICE-VERSA).

ALTERNATE PHASING PAGE CHANGE SUMMARY

THE FOLLOWING IS A SUMMARY OF WHAT TAKES PLACE WHEN THESE OVERLAP/INPUT PAGE CHANGES ACTIVATE TO CALL THE "ALTERNATE PHASING":

OVERLAPS PAGE 2: Modifies overlap parent phases for head 51 to run protected turns only.

INPUTS PAGE 2: Disables phase 2 call on loop 5A and reduces delay time for phase 5 call on loop 5A to 3 seconds.

DYNAMIC BACK-UP CONTROL PROGRAMMING

(program controller as shown below)

1. From Main Menu press '2' (Phase Control), then '1' (Phase Control Functions). Scroll to the bottom of the menu and enable Dynamic/Backup Control Functions 1 and 2.
2. From Phase Control Functions Menu press '2' (Dynamic/Backup Control Functions).

```

DYNAMIC/BACKUP CONTROL FUNCTION #01
OVERLAPS: ABCDEFGHIJKLMNOP
IF OVERLAPS ARE ACTIVE:
OR PHASES: 12345678910111213141516
IF PHASES ARE ON: X
OMIT PHASES: X
CALL PHASES: X
    
```



BACKUP PROTECTION PROGRAMMING COMPLETE

THIS ELECTRICAL DETAIL IS FOR
 THE SIGNAL DESIGN: 03-0901T3
 DESIGNED: June 2017
 SEALED: 9/10/2021
 REVISED: N/A

Electrical Detail - Sheet 4 of 4
 Signal Upgrade
 Temporary Design 3

**DOCUMENT NOT CONSIDERED FINAL
 UNLESS ALL SIGNATURES COMPLETED**

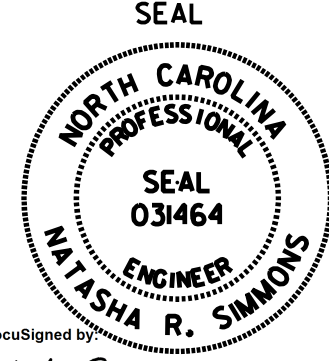
HNTB HNTB NORTH CAROLINA, P.C.
 343 E. Six Forks Road, Suite 200
 Raleigh, North Carolina 27609
 NC License No: C-1554
 (919) 546-8997

ELECTRICAL AND PROGRAMMING DETAILS FOR:	NC 211 (Southport-Supply Road) at NC 906 (Midway Road/ Middleton Boulevard) Division 03 Brunswick Co. Southport	SEAL 
Prepared for: 	PLAN DATE: June 2017 REVIEWED BY: A.D. Klinksiek PREPARED BY: A.H. Thornburg REVIEWED BY: N.R. Simmons	DocuSigned by: Natasha Simmons 9/10/2021
750 N. Greenfield Pkwy, Corner, NC 27529	REVISIONS INIT. DATE	SIGNATURE DATE SIG. INVENTORY NO. 03-0901T3

PHASING DIAGRAM

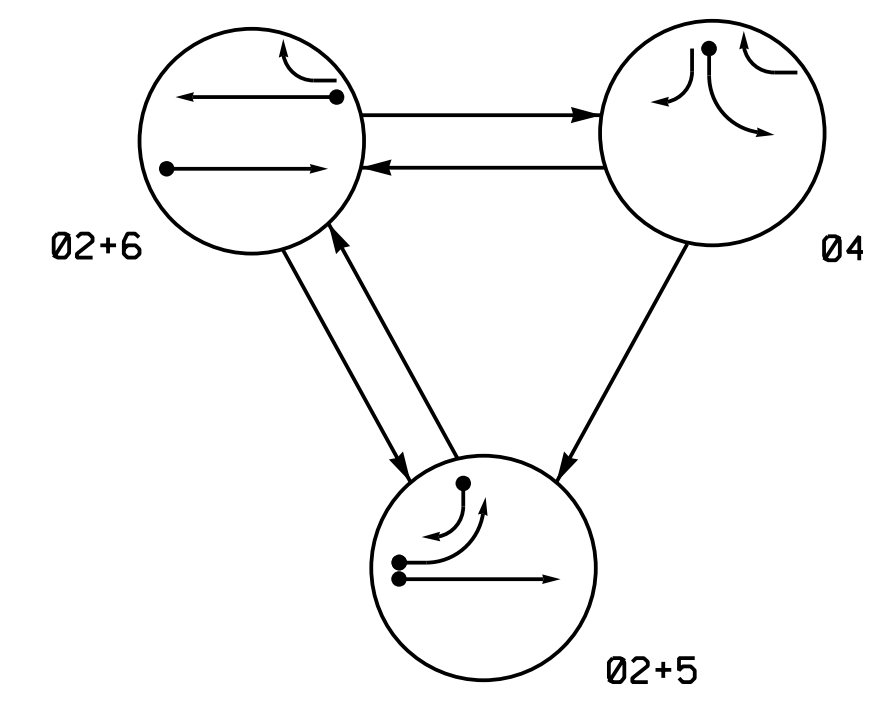

PHASING DIAGRAM DETECTION LEGEND

- DETECTED MOVEMENT
- ← UNDETECTED MOVEMENT (OVERLAP)
- ⋯ UNSIGNALIZED MOVEMENT
- ⚡ PEDESTRIAN MOVEMENT

SIGNAL FACE	PHASE			
	02+5	02+6	04	FLASH
21,22	G	G	R	Y
41	R	R	G	R
42	R	R	G	R
51	R	R	R	R
61	R	G	R	Y
62	R	G	R	Y

SIGNAL FACE I.D.

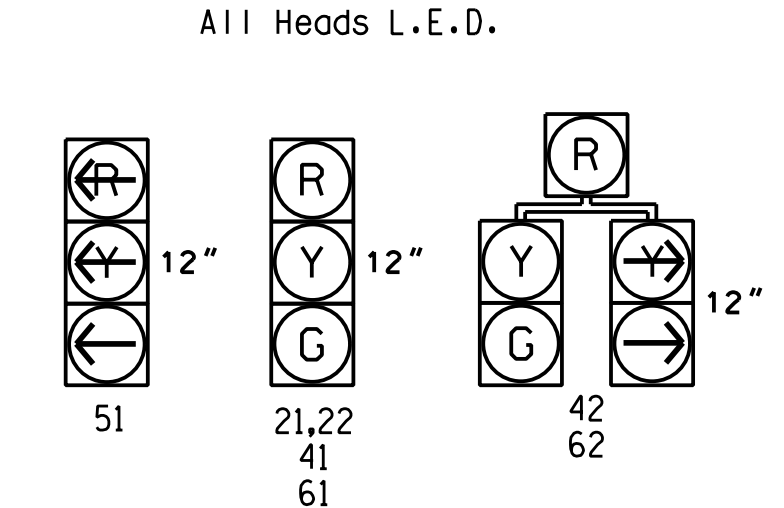

OASIS 2070E LOOP & DETECTOR INSTALLATION CHART

LOOP	SIZE (FT)	DISTANCE FROM STOPBAR (FT)	TURNS	NEW LOOP	DETECTOR PROGRAMMING				SYSTEM LOOP	NEW CARD
					PHASE	CALLING	EXTENSION	FULL TIME DELAY		
2A	6X6	420	6	Y	2	Y	Y	-	-	Y
4A	6X40	0	*	*	4	Y	Y	-	-	-
5A	6X40	0	*	*	5	Y	Y	-	-	-
5B	6X40	0	*	*	5	Y	Y	-	15	-
6A	6X6	420	*	*	6	Y	Y	-	-	-

* Multizone Microwave Detection.

3 Phase Fully Actuated Isolated

NOTES

- Refer to "Roadway Standard Drawings NCDOT" dated January 2018 and "Standard Specifications for Roads and Structures" dated January 2018.
- Do not program signal for late night flashing operation unless otherwise directed by the Engineer.
- Phase 5 may be lagged.
- Set all detector units to presence mode.
- Locate new cabinet so as not to obstruct sight distance of vehicles turning right on red.
- Incorporate Microwave Detection system for vehicle detection.
- Provide the Engineer with the Manufacturer's approved Microwave Detection locations and mounting heights to obtain detection zones as shown.

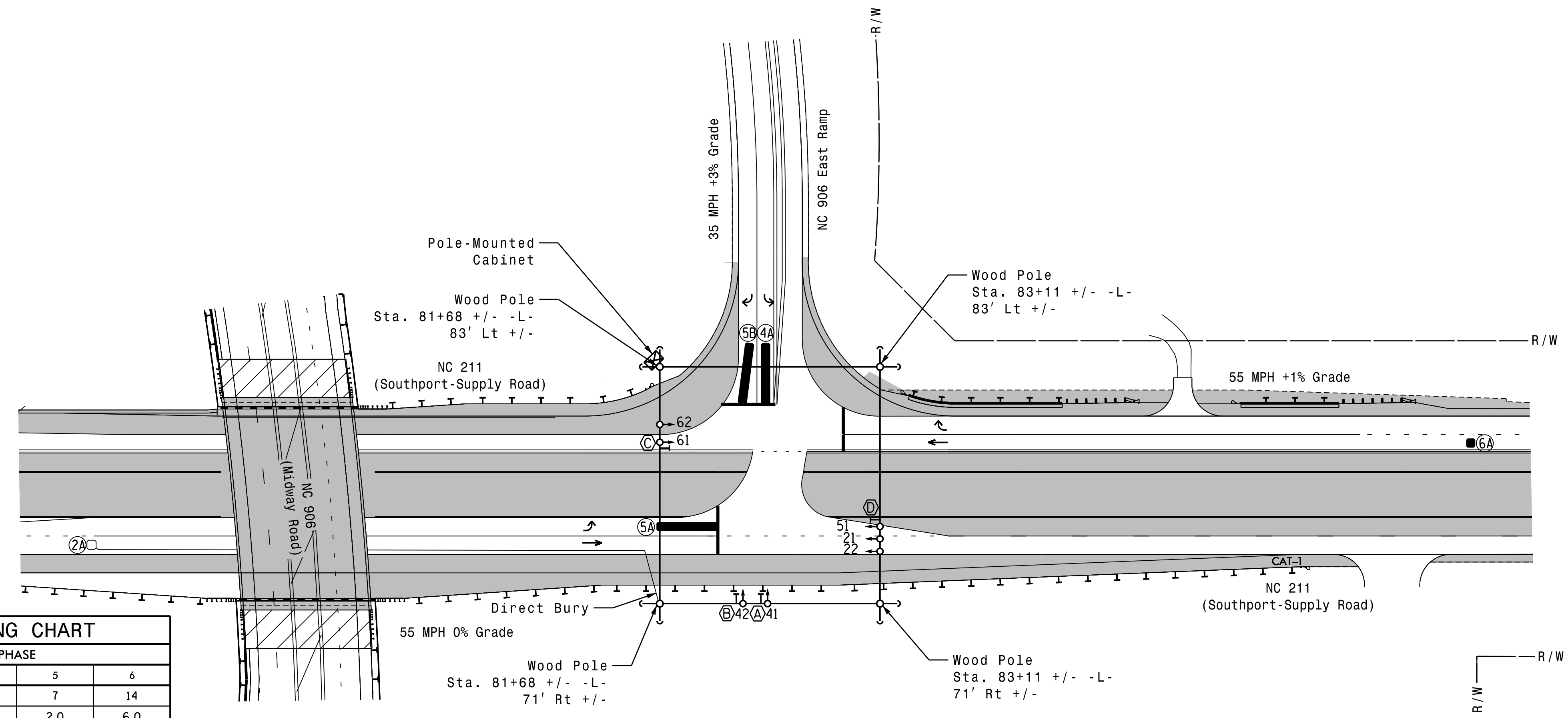

FEATURE	PHASE			
	2	4	5	6
Min Green 1 *	14	7	7	14
Extension 1 *	6.0	2.0	2.0	6.0
Max Green 1 *	90	40	30	90
Yellow Clearance	5.2	3.0	3.0	5.1
Red Clearance	1.0	3.1	3.1	1.0
Red Revert	2.0	2.0	2.0	2.0
Walk 1 *	-	-	-	-
Don't Walk 1	-	-	-	-
Seconds Per Actuation *	2.5	-	-	2.5
Max Variable Initial *	46	-	-	46
Time Before Reduction *	15	-	-	15
Time To Reduce *	45	-	-	45
Minimum Gap	3.4	-	-	3.4
Recall Mode	MIN RECALL	-	-	MIN RECALL
Vehicle Call Memory	YELLOW	-	-	YELLOW
Dual Entry	-	-	-	-
Simultaneous Gap	ON	ON	ON	ON

* These values may be field adjusted. Do not adjust Min Green and Extension times for phases 2 and 6 lower than what is shown. Min Green for all other phases should not be lower than 4 seconds.

PROPOSED	LEGEND	EXISTING
○→	Traffic Signal Head	●→
○→	Modified Signal Head	N/A
⊥	Sign	⊥
⊥	Pedestrian Signal Head With Push Button & Sign	⊥
○→	Signal Pole with Guy	○→
○→	Signal Pole with Sidewalk Guy	○→
⊞	Inductive Loop Detector	⊞
⊞	Controller & Cabinet	⊞
⊞	Junction Box	⊞
⊞	2-in Underground Conduit	⊞
N/A	Right of Way	---
→	Directional Arrow	→
▬	Microwave Detection Zone	▬
▬	Construction Zone	N/A
(A)	Left Turn "ONLY" (R3-5L)	(A)
(B)	Right Turn "ONLY" (R3-5R)	(B)
(C)	No U-Turn/No Left Turn Sign (R3-18)	(C)
(D)	No U-Turn Sign (R3-4)	(D)

Signal Upgrade
Temporary Design 4
Construction Phase 3

DOCUMENT NOT CONSIDERED FINAL UNLESS ALL SIGNATURES COMPLETED

	NC 211 (Southport-Supply Road) at NC 906 East Ramp		
	Division 03 Brunswick Co. Southport PLAN DATE: June 2017 REVIEWED BY: A.D. Klinksiek PREPARED BY: A.H. Thornburg REVIEWED BY: N.R. Simmons	SEAL NORTH CAROLINA PROFESSIONAL ENGINEER NATASHA R. SIMMONS 9/10/2021 SIGNATURE DATE SIG. INVENTORY NO. 03-0901T4	

HNTB HNTB NORTH CAROLINA, P.C.
343 E. Six Forks Road, Suite 200
Raleigh, North Carolina 27609
NC License No: C-1554
(919) 546-8997

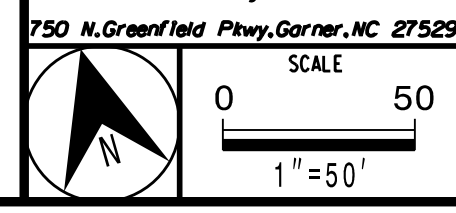

EDI MODEL 2018ECL-NC CONFLICT MONITOR PROGRAMMING DETAIL

(remove jumpers and set switches as shown)

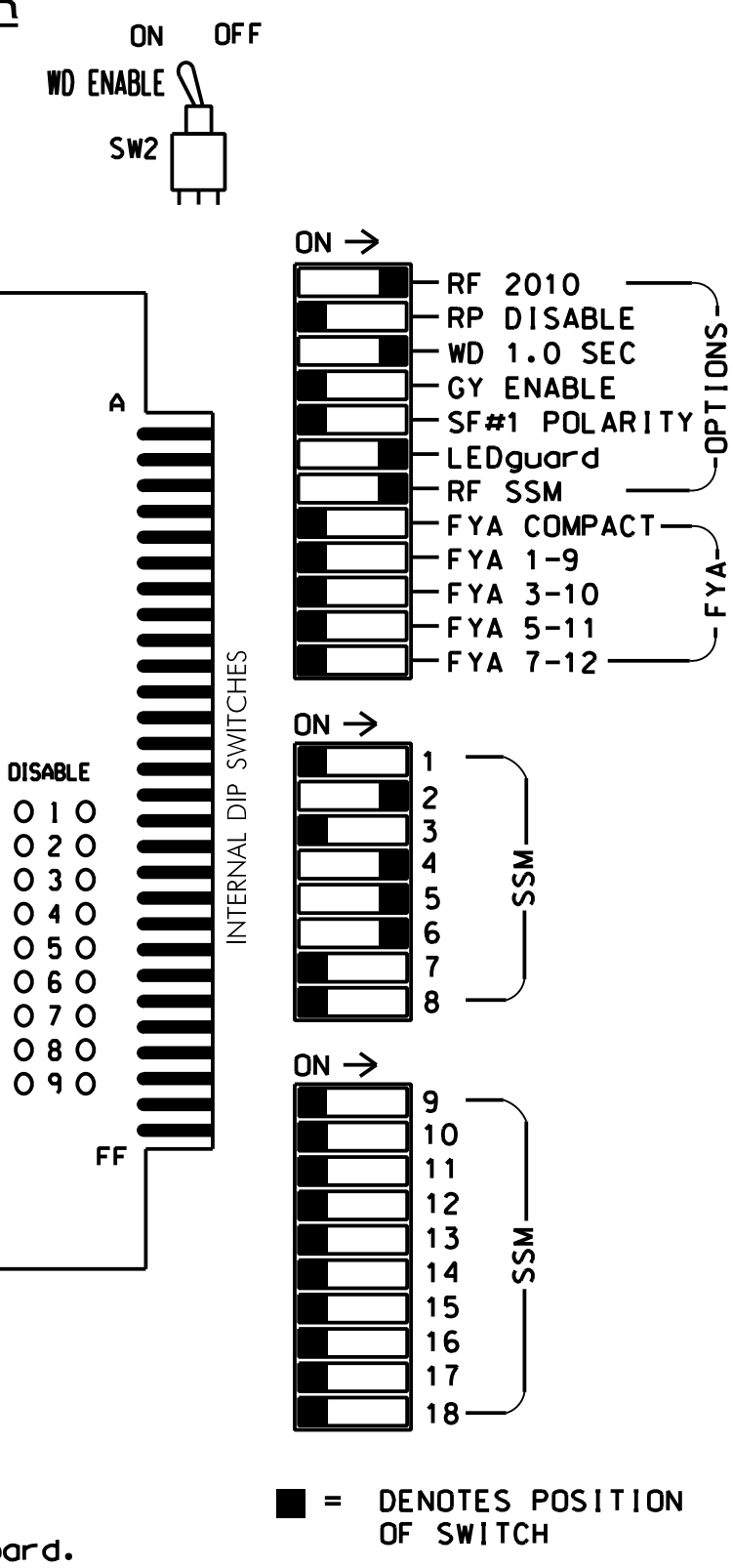
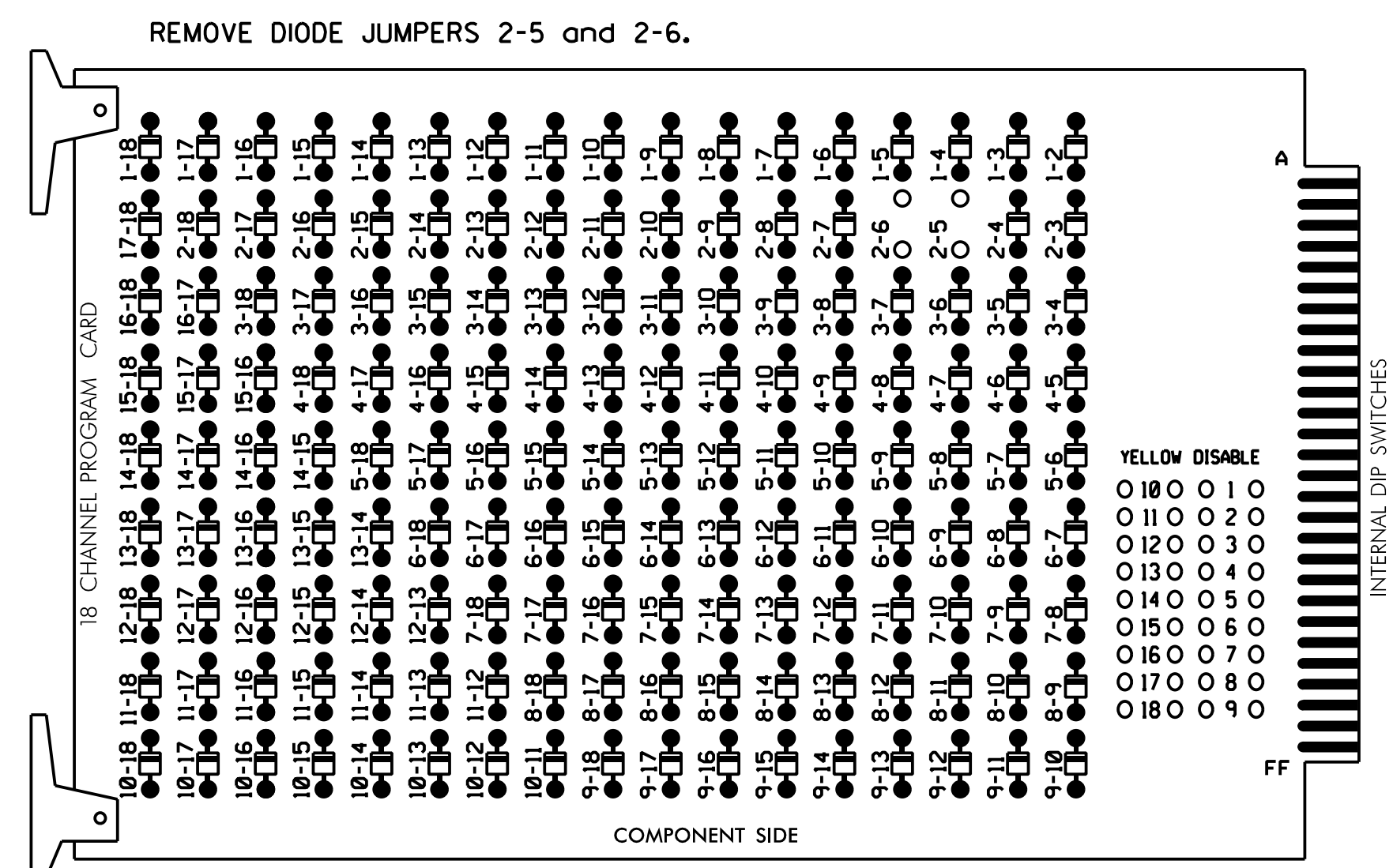

NOTES:

1. Card is provided with all diode jumpers in place. Removal of any jumper allows its channels to run concurrently.
2. Ensure jumpers SEL2-SEL5 and SEL9 are present on the monitor board.
3. Ensure that Red Enable is active at all times during normal operation.
4. Connect serial cable from conflict monitor to comm. port 1 of 2070 controller. Ensure conflict monitor communicates with 2070.

NOTES

1. To prevent "flash-conflict" problems, insert red flash program blocks for all unused vehicle load switches in the output file. The installer shall verify that signal heads flash in accordance with the Signal Plans.
2. Enable Simultaneous Gap-Out for all Phases.
3. Program phases 2 and 6 for Variable Initial and Gap Reduction.
4. Program phases 2 and 6 for Startup In Green.
5. Program phases 2 and 6 for Yellow Flash.
6. If this signal will be managed by an ATMS software, enable controller and detector logging for all detectors used at this location.

EQUIPMENT INFORMATION

CONTROLLER.....2070E
 CABINET.....336
 SOFTWARE.....ECONOLITE OASIS
 CABINET MOUNT.....POLE
 OUTPUT FILE POSITIONS...12
 LOAD SWITCHES USED.....S2,S5,S7,S8
 PHASES USED.....2,4,5,6

SIGNAL HEAD HOOK-UP CHART

LOAD SWITCH NO.	S1	S2	S3	S4	S5	S6	S7	S8	S9	S10	S11	S12
CMU CHANNEL NO.	1	2	13	3	4	14	5	6	15	7	8	16
PHASE	1	2	2 PED	3	4	4 PED	5	6	6 PED	7	8	8 PED
SIGNAL HEAD NO.	NU	21,22	NU	NU	41,42	62	NU	42	51	61,62	NU	NU
RED		128			101					134		
YELLOW		129			102					135		
GREEN		130			103					136		
RED ARROW										131		
YELLOW ARROW					102			132	132			
GREEN ARROW					103			133	133			

NU = Not Used

INPUT FILE POSITION LAYOUT

(front view)

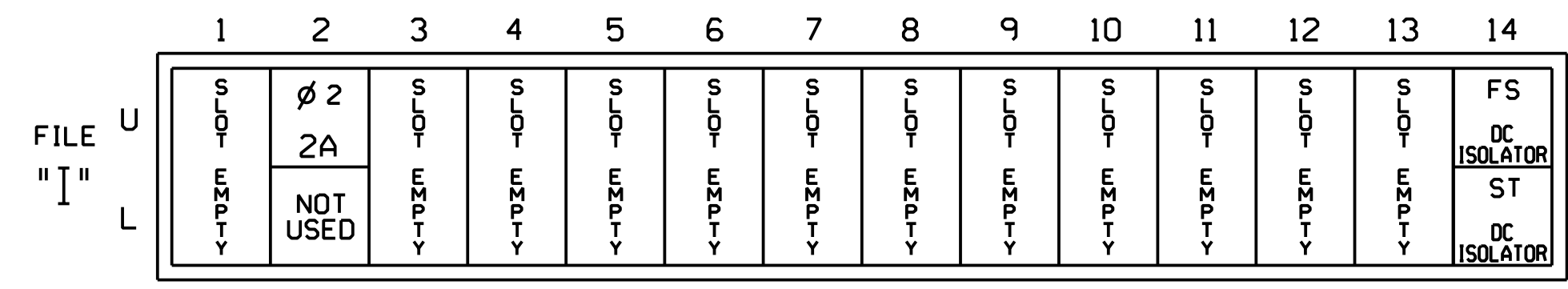

SPECIAL DETECTOR NOTE

For loops 4A, 5A, 5B, and 6A install a microwave detection system for vehicle detection. Perform installation according to manufacturer's directions and NCDOT engineer-approved mounting locations to accomplish the detection schemes shown on the Signal Design Plans.

INPUT FILE CONNECTION & PROGRAMMING CHART

LOOP NO.	LOOP TERMINAL	INPUT FILE POS.	PIN NO.	INPUT ASSIGNMENT NO.	DETECTOR NO.	NEMA PHASE	CALL	EXTEND	FULL TIME DELAY	STRETCH TIME	DELAY TIME
2A	TB21-3,4	12U	39	1	2	2	Y	Y	-	-	-

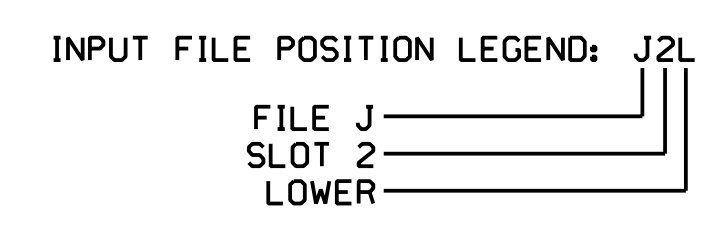

THIS ELECTRICAL DETAIL IS FOR THE SIGNAL DESIGN: 03-0901T4
 DESIGNED: June 2017
 SEALED: 9/10/2021
 REVISED: N/A

Electrical Detail - Sheet 1 of 1
 Signal Upgrade
 Temporary Design 4

DOCUMENT NOT CONSIDERED FINAL UNLESS ALL SIGNATURES COMPLETED

	Prepared for: 		NC 211 (Southport-Supply Road) at NC 906 East Ramp		SEAL
	Division 03 Brunswick Co. Southport		PLAN DATE: June 2017 REVIEWED BY: A.D. Klinksiek PREPARED BY: A.H. Thornburg REVIEWED BY: N.R. Simmons		
HNTB NORTH CAROLINA, P.C. 343 E. Six Forks Road, Suite 200 Raleigh, North Carolina 27609 NC license No: C-1554 (919) 546-8997		REVISIONS INIT. DATE		SIGNATURE DATE Natasha Simmons 9/10/2021 SIG. INVENTORY NO. 03-0901T4	

DEFAULT PHASING DIAGRAM

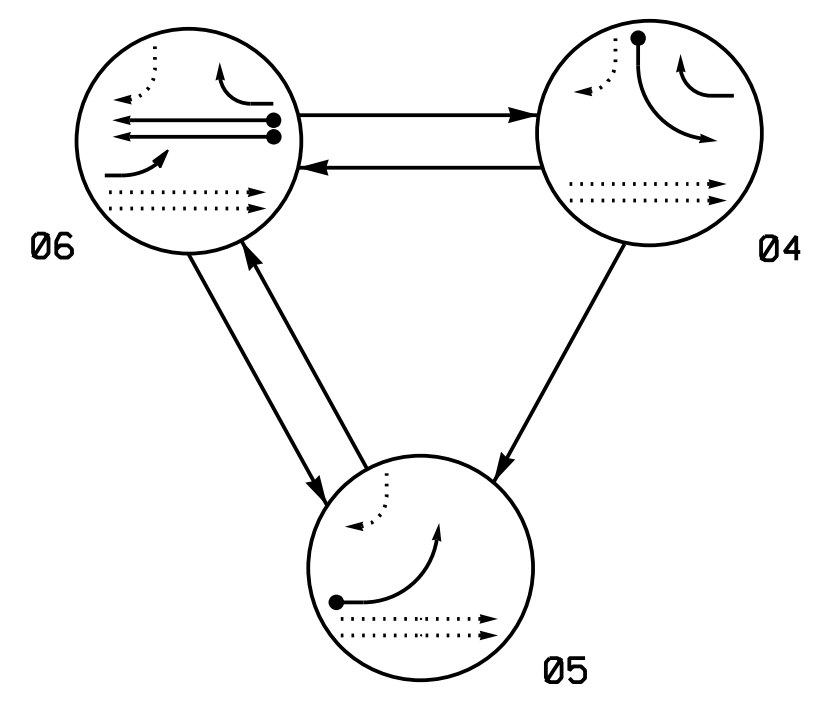

ALTERNATE PHASING DIAGRAM

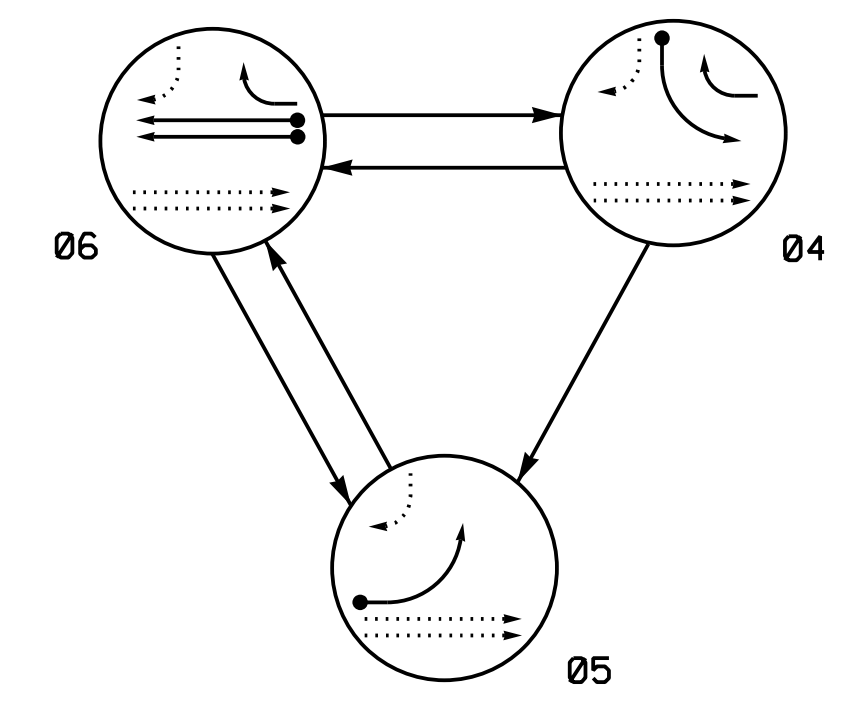

PHASING DIAGRAM DETECTION LEGEND

- ←● DETECTED MOVEMENT
- ← UNDETECTED MOVEMENT (OVERLAP)
- ←... UNSIGNALIZED MOVEMENT
- ←- - - PEDESTRIAN MOVEMENT

DEFAULT PHASING TABLE OF OPERATION

SIGNAL FACE	PHASE			
	05	06	04	F L
41,42	R	R	G	R
51,52	-	R	R	Y
61	R	G	R	Y
62	R	G	R	Y

ALTERNATE PHASING TABLE OF OPERATION

SIGNAL FACE	PHASE			
	05	06	04	F L
41,42	R	R	G	R
51,52	-	R	R	Y
61	R	G	R	Y
62	R	G	R	Y

SIGNAL FACE I.D.
All Heads L.E.D.

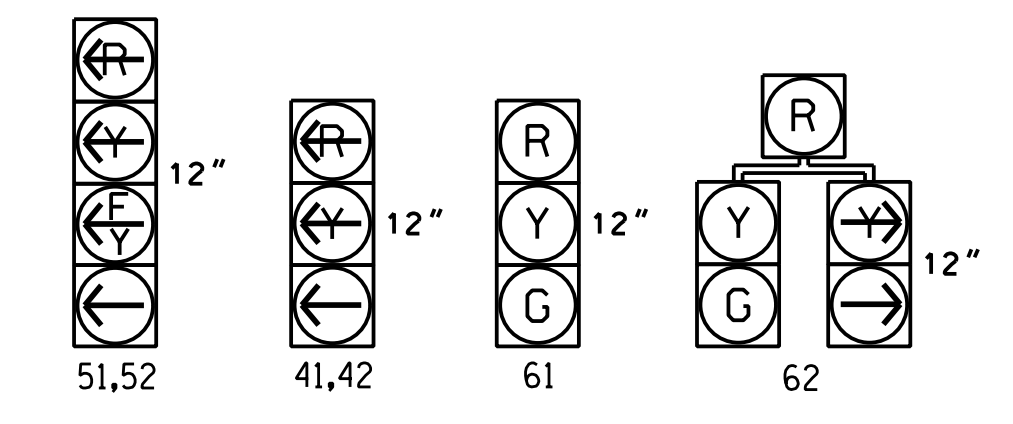

OASIS 2070 LOOP & DETECTOR INSTALLATION CHART

LOOP	SIZE (FT)	DISTANCE FROM STOPBAR (FT)	TURNS	NEW LOOP	DETECTOR PROGRAMMING							
					PHASE	CALLING	EXTENSION	FULL TIME DELAY	STRETCH TIME	DELAY TIME	SYSTEM LOOP	NEW CARD
4A	6X40	0	2-4-2	Y	4	Y	Y	-	-	-	-	Y
5A	6X40	0	2-4-2	Y	5	Y	Y	-	-	*15	-	Y
6A/S01	6X6	300	5	Y	6	Y	Y	-	-	-	-	Y
6B/S02	6X6	300	5	Y	6	Y	Y	-	-	-	-	Y

* Reduce delay to 0 seconds during alternate phasing operation.

3 Phase Fully Actuated (NC 133 Closed Loop System)

NOTES

- Refer to "Roadway Standard Drawings NCDOT" dated January 2018 and "Standard Specifications for Roads and Structures" dated January 2018.
- Do not program signal for late night flashing operation unless otherwise directed by the Engineer.
- Phase 5 may be lagged.
- Set all detector units to presence mode.
- Locate new cabinet so as to not obstruct sight distance of vehicles turning right on red.
- The Division Traffic Engineer will determine the hours of use for each phasing plan.
- Maximum times shown in timing chart are for free-run operation only. Coordinated signal system timing values supersede these values.
- Closed loop system data: Controller Asset #: 1123.

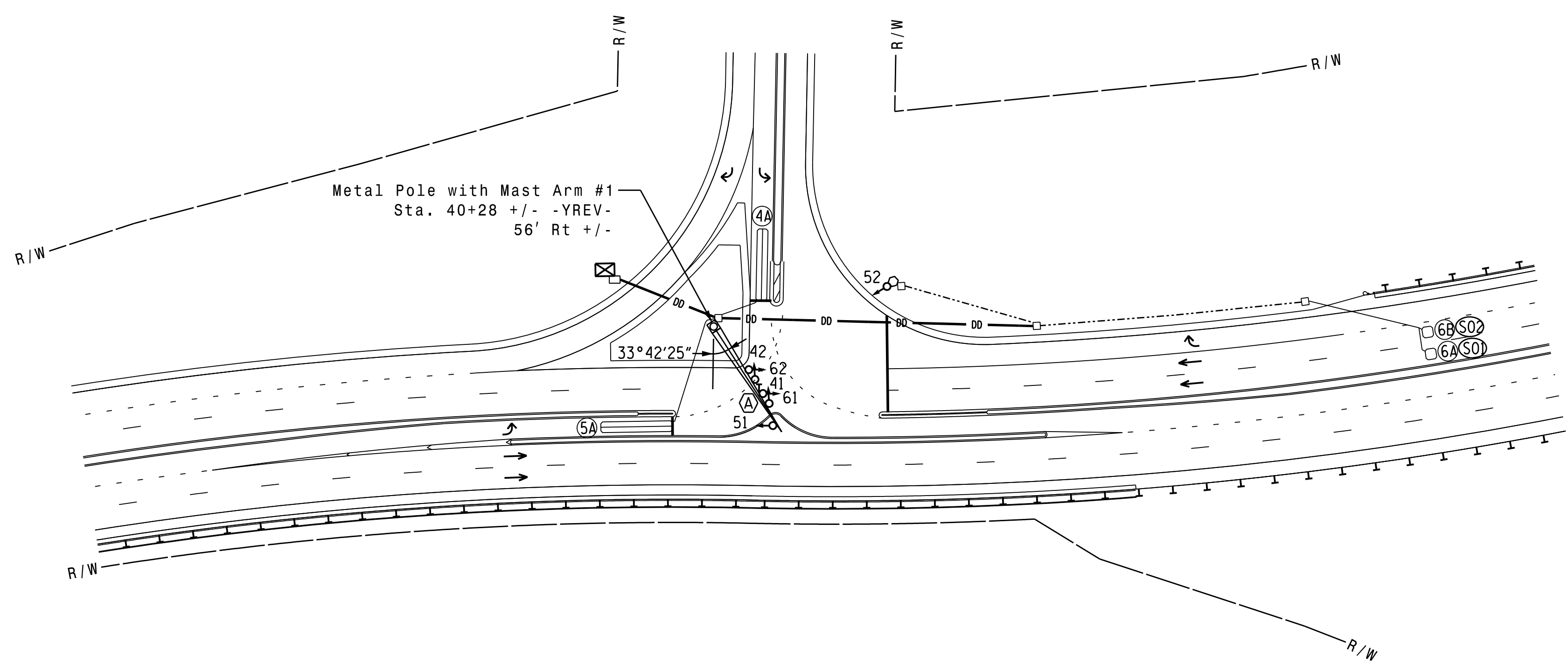

OASIS 2070 TIMING CHART

FEATURE	PHASE		
	4	5	6
Min Green 1 *	7	7	12
Extension 1 *	2.0	2.0	6.0
Max Green 1 *	30	20	60
Yellow Clearance	3.0	3.0	4.9
Red Clearance	3.3	2.8	1.3
Red Revert	2.0	2.0	2.0
Walk 1 *	-	-	-
Don't Walk 1	-	-	-
Seconds Per Actuation *	-	-	1.5
Max Variable Initial *	-	-	34
Time Before Reduction *	-	-	15
Time To Reduce *	-	-	30
Minimum Gap	-	-	3.0
Recall Mode	-	-	MIN RECALL
Vehicle Call Memory	-	-	YELLOW
Dual Entry	-	-	-
Simultaneous Gap	ON	ON	ON

* These values may be field adjusted. Do not adjust Min Green and Extension times for phase 6 lower than what is shown. Min Green for all other phases should not be lower than 4 seconds.

LEGEND

PROPOSED	EXISTING
○ → Traffic Signal Head	● → N/A
○ → Modified Signal Head	○ → N/A
□ → Pedestrian Signal Head With Push Button & Sign	□ → N/A
○ → Signal Pole with Guy	○ → N/A
○ → Signal Pole with Sidewalk Guy	○ → N/A
□ → Inductive Loop Detector	□ → N/A
□ → Controller & Cabinet	□ → N/A
□ → Junction Box	□ → N/A
□ → 2-in Underground Conduit	□ → N/A
→ Right of Way	→ N/A
→ Directional Arrow	→ N/A
→ Directional Drill	→ N/A
○ → Metal Pole with Mastarm	○ → N/A
— Guardrail	— N/A
○ Type III Signal Pedestal	● N/A
ⓐ Left Arrow "ONLY" Sign (R3-5L)	ⓐ N/A

New Installation
Final Design

DOCUMENT NOT CONSIDERED FINAL UNLESS ALL SIGNATURES COMPLETED

	Prepared For: TRANSPORTATION MOBILITY AND SAFETY DIVISION NORTH CAROLINA DEPARTMENT OF TRANSPORTATION SIGNAL DESIGN SECTION	NC 906 (Middleton Boulevard) at NC 211 Southbound Ramp Division 03 Brunswick Co. Southport PLAN DATE: June 2017 REVIEWED BY: A.D. Klinksiek PREPARED BY: A.H. Thornburg REVIEWED BY: N.R. Simmons	SEAL
	750 N. Greenfield Pkwy, Garner, NC 27529 SCALE: 0 50 1" = 50'	SIGNATURE: DATE: 9/10/2021 SIG. INVENTORY NO. 03-1123	

HNTB HNTB NORTH CAROLINA, P.C.
343 E. Six Forks Road, Suite 200
Raleigh, North Carolina 27609
NC License No: C-1554
(919) 546-8997

EDI MODEL 2018ECL-NC CONFLICT MONITOR PROGRAMMING DETAIL

(remove jumpers and set switches as shown)

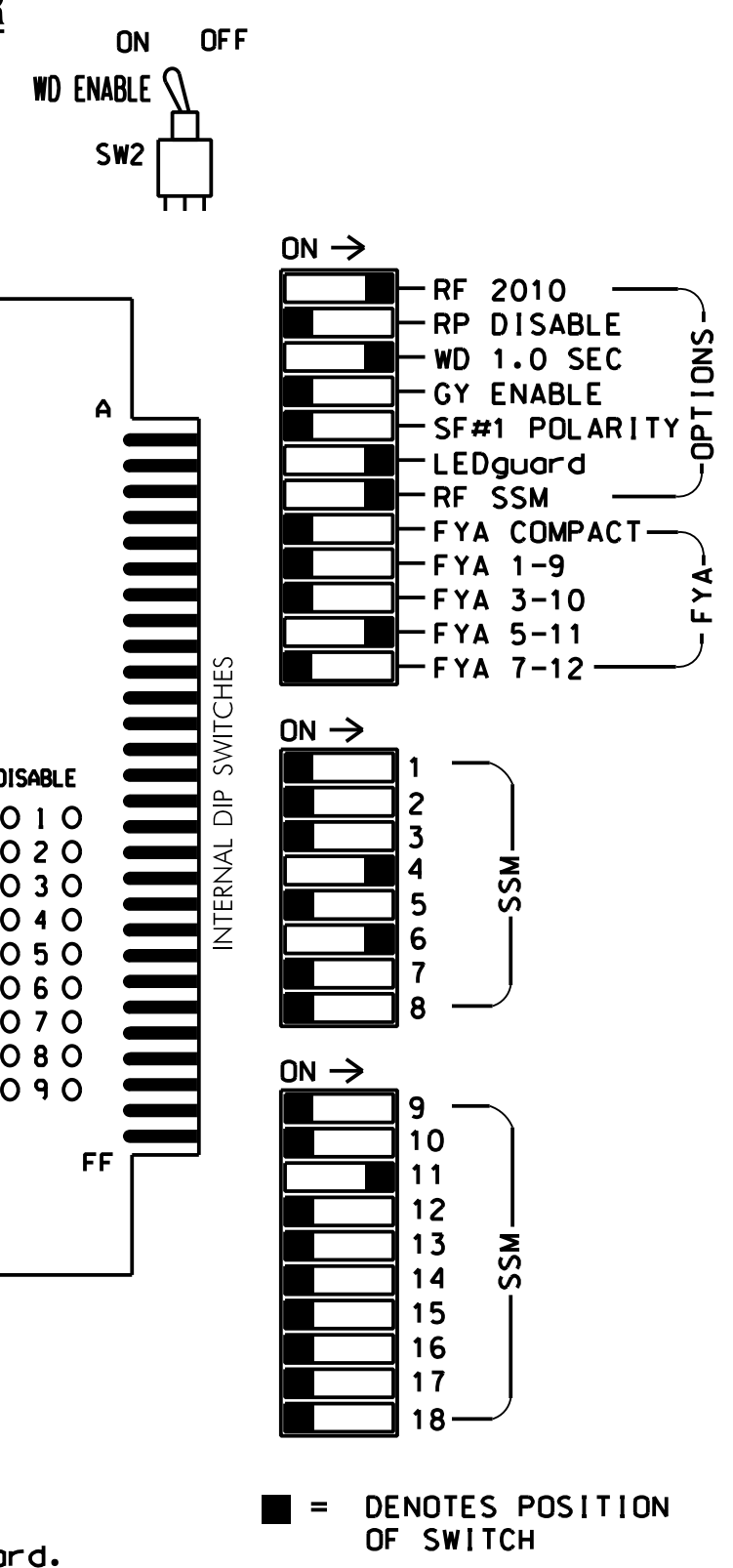
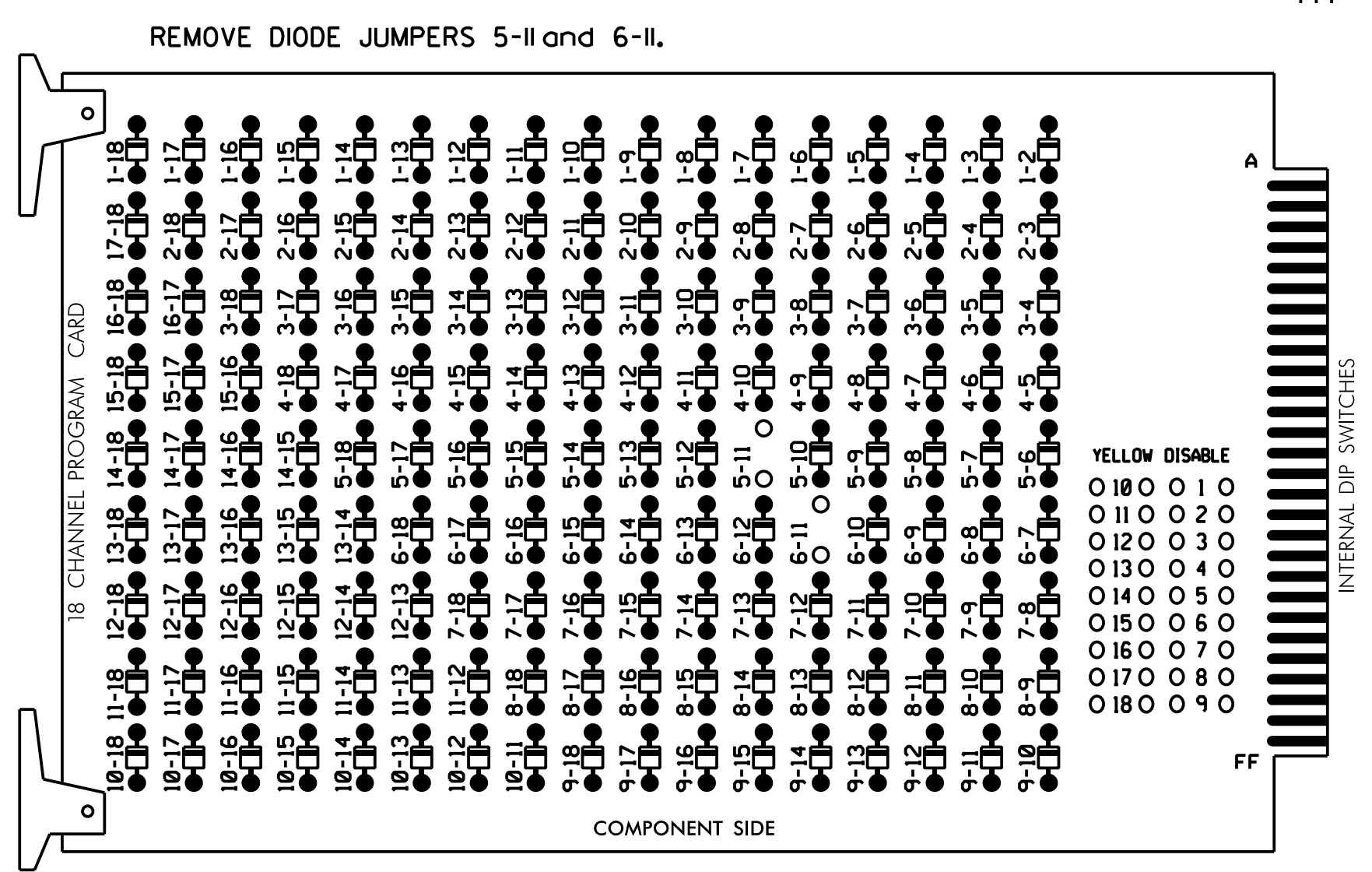

NOTES:

- Card is provided with all diode jumpers in place. Removal of any jumper allows its channels to run concurrently.
- Ensure jumpers SEL2-SEL5 and SEL9 are present on the monitor board.
- Ensure that Red Enable is active at all times during normal operation.
- Connect serial cable from conflict monitor to comm. port 1 of 2070 controller. Ensure conflict monitor communicates with 2070.

NOTES

- To prevent "flash-conflict" problems, insert red flash program blocks for all unused vehicle load switches in the output file. The installer shall verify that signal heads flash in accordance with the Signal Plans.
- Enable Simultaneous Gap-Out for all Phases.
- Program phase 6 for Variable Initial and Gap Reduction.
- Program phase 6 for Startup In Green.
- Program phase 6 for Yellow Flash.
- If this signal will be managed by an ATMS software, enable controller and detector logging for all detectors used at this location.
- The cabinet and controller are part of the NC 133 Closed Loop System.

EQUIPMENT INFORMATION

CONTROLLER.....2070E
 CABINET332 W/ AUX
 SOFTWAREECONOLITE OASIS
 CABINET MOUNT.....BASE
 OUTPUT FILE POSITIONS..18 WITH AUX. OUTPUT FILE
 LOAD SWITCHES USED....S5,S7,S8,AUX S4
 PHASES USED.....4,5,6
 OVERLAP "A".....NOT USED
 OVERLAP "B".....NOT USED
 OVERLAP "C".....5+6
 OVERLAP "D".....NOT USED

SIGNAL HEAD HOOK-UP CHART

LOAD SWITCH NO.	S1	S2	S3	S4	S5	S6	S7	S8	S9	S10	S11	S12	AUX S1	AUX S2	AUX S3	AUX S4	AUX S5	AUX S6	
CMU CHANNEL NO.	1	2	13	3	4	14	5	6	15	7	8	16	9	10	17	11	12	18	
PHASE	1	2	2 PED	3	4	4 PED	5	6	6 PED	7	8	8 PED	OLA	OLB	SPARE	OLC	OLD	SPARE	
SIGNAL HEAD NO.	NU	NU	NU	NU	41,42	62	NU	51,52	61,62	NU	NU	NU	NU	NU	NU	51,52	NU	NU	
RED									134										
YELLOW								*	135										
GREEN									136										
RED ARROW					101													A114	
YELLOW ARROW					102	102													A115
FLASHING YELLOW ARROW																			A116
GREEN ARROW					103	103		133											

NU = Not Used

- * Denotes install load resistor. See load resistor installation detail this sheet.
- ★ See pictorial of head wiring in detail this sheet.

FYA SIGNAL WIRING DETAIL

(wire signal heads as shown)

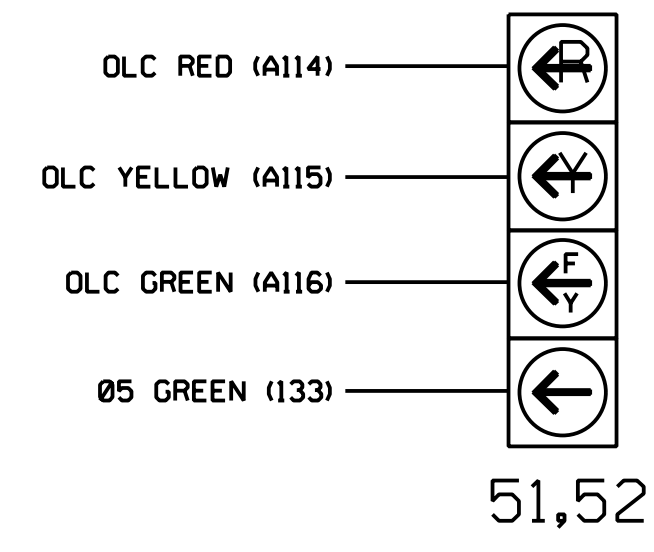

NOTE

The sequence display for signal heads 51,52 requires special logic programming. See sheet 2 for programming instructions.

INPUT FILE POSITION LAYOUT

(front view)

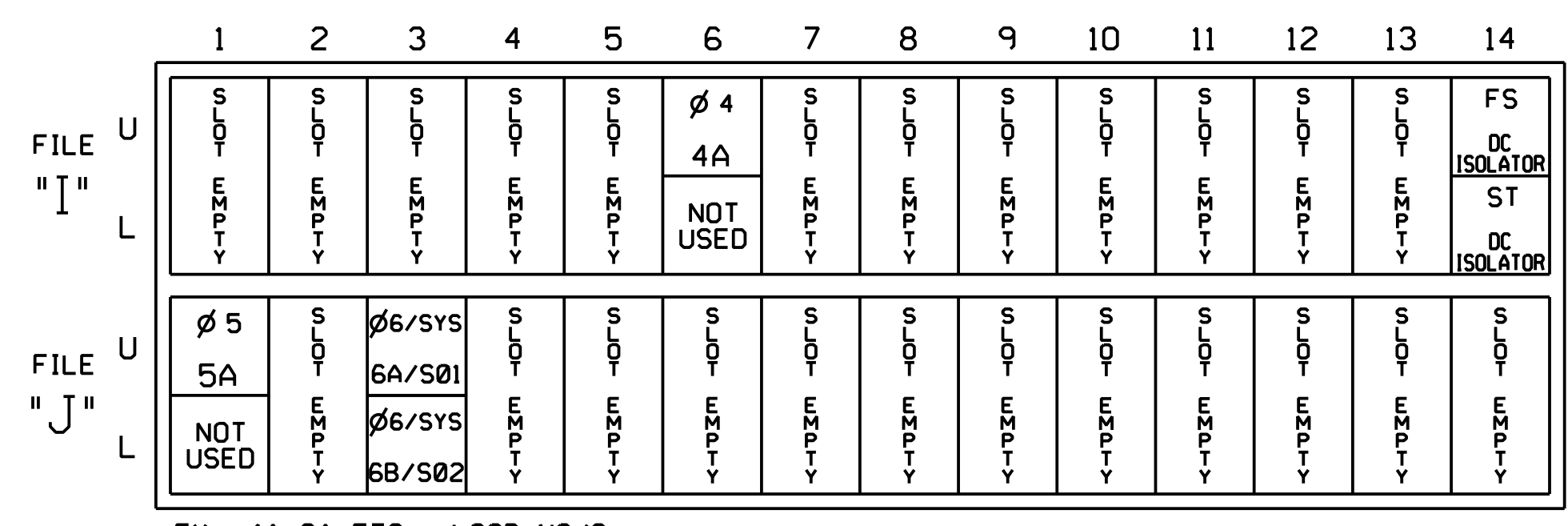

EX.: 1A, 2A, ETC. = LOOP NO.'S

FS = FLASH SENSE
 ST = STOP TIME

INPUT FILE CONNECTION & PROGRAMMING CHART

LOOP NO.	LOOP TERMINAL	INPUT FILE POS.	PIN NO.	INPUT ASSIGNMENT NO.	DETECTOR NO.	NEMA PHASE	CALL	EXTEND	FULL TIME DELAY	STRETCH TIME	DELAY TIME
4A	TB4-9,10	I6U	41	3	4	4	Y	Y			
5A	TB3-1,2	J1U	55	17	5	5	Y	Y			15
	-	J1U	55	17★	55	5	Y	Y			
6A/S01	TB3-9,10	J3U	64	26	36	6/SYS	Y	Y			
6B/S02	TB3-11,12	J3L	77	39	46	6/SYS	Y	Y			

★ See vehicle detector setup programming detail for alternate phasing on sheet 3.

INPUT FILE POSITION LEGEND: J2L

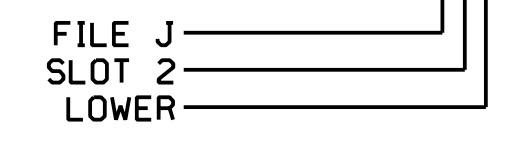

LOAD RESISTOR INSTALLATION DETAIL

(install resistor as shown)

ACCEPTABLE VALUES	VALUE (ohms)	WATTAGE
	1.5K - 1.9K	25W (min)
	2.0K - 3.0K	10W (min)

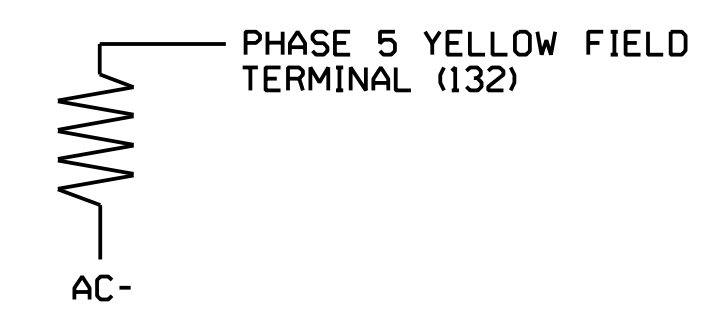

THIS ELECTRICAL DETAIL IS FOR THE SIGNAL DESIGN: 03-1123
 DESIGNED: June 2017
 SEALED: 9/10/2021
 REVISED: N/A

Electrical Detail - Sheet 1 of 4
 New Installation
 Final Design

DOCUMENT NOT CONSIDERED FINAL UNLESS ALL SIGNATURES COMPLETED

	Prepared for: 		NC 906 (Middleton Boulevard) at NC 211 Southbound Ramp		SEAL
	Prepared by: A.H. Thornburg		Reviewed by: N.R. Simmons		
PLAN DATE: June 2017		REVIEWED BY: A.D. Klinksiek		DATE: 9/10/2021	
REVISIONS		INIT.		DATE	
SIGNATURE		DATE		DATE: 9/10/2021	
SIGNATURE		DATE		SIG. INVENTORY NO. 03-1123	

HNTB HNTB NORTH CAROLINA, P.C.
 343 E. Six Forks Road, Suite 200
 Raleigh, North Carolina 27609
 NC License No: C-1554
 (919) 546-8997

**LOGICAL I/O PROCESSOR PROGRAMMING DETAIL
TO PRODUCE SPECIAL FYA-PPLT SIGNAL SEQUENCE**

(program controller as shown below)

- FROM MAIN MENU PRESS '2' (PHASE CONTROL), THEN '1' (PHASE CONTROL FUNCTIONS), SCROLL TO THE BOTTOM OF THE MENU AND ENABLE ACT LOGIC COMMANDS 1, 2, AND 3.

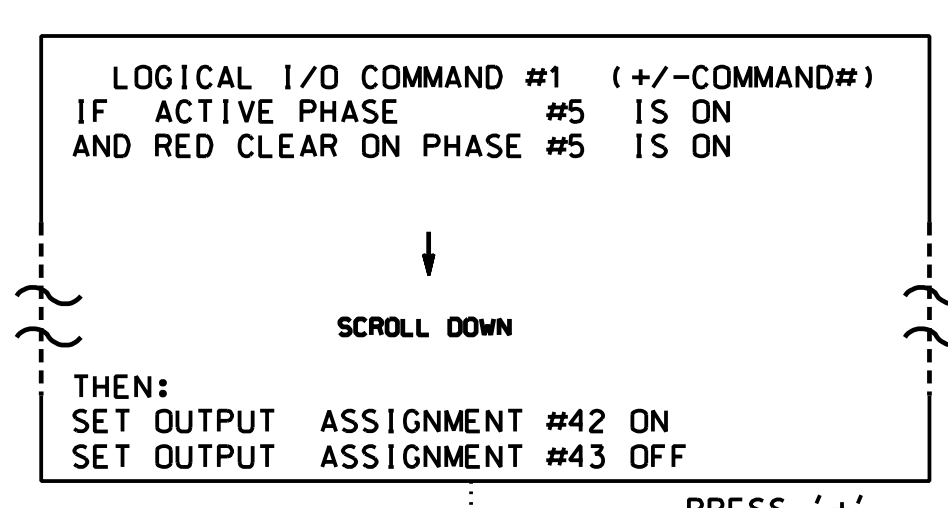

NOTE: LOGIC FOR PHASE 5 RED CLEAR WHEN TRANSITIONING FROM PHASE 5 TO PHASE 6 (HEADS 51.52).

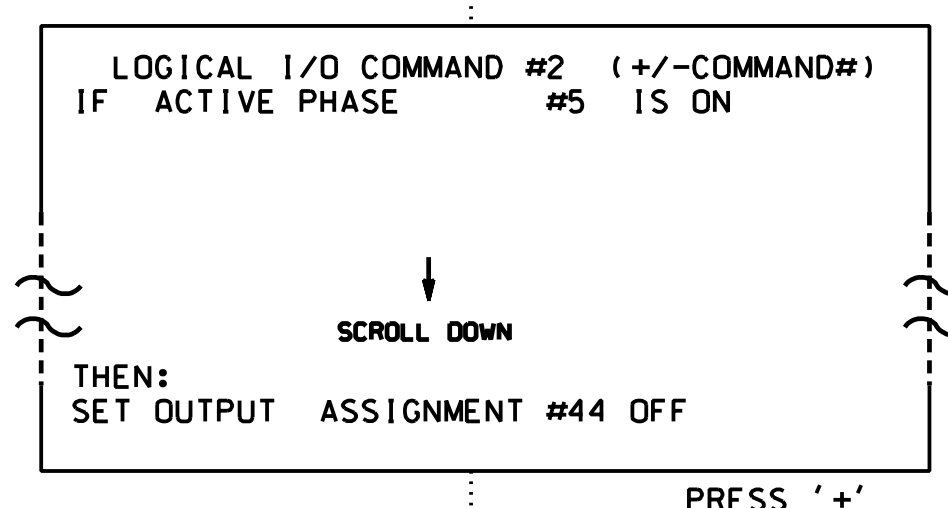

NOTE: LOGIC FOR SWITCHING FLASHING YELLOW ARROW "OFF" DURING PHASE 5 (HEADS 51.52).

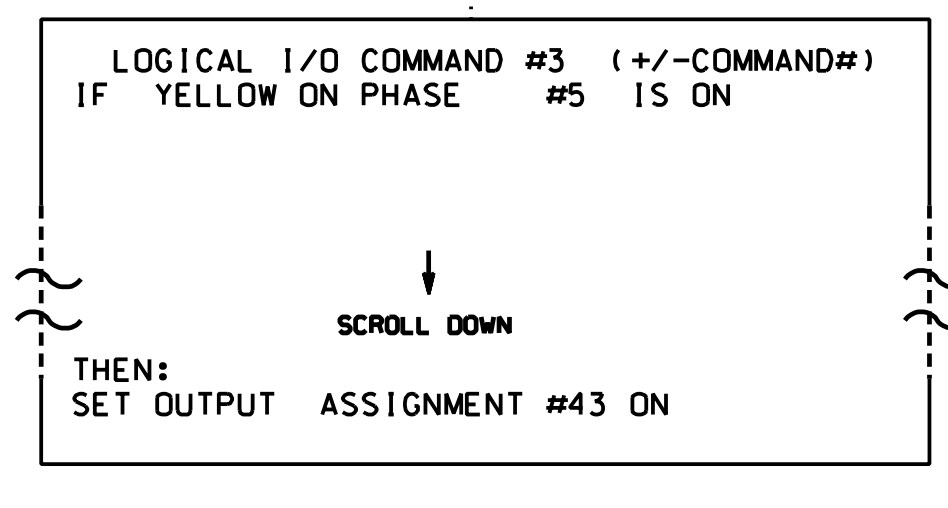

NOTE: LOGIC FOR YELLOW ARROW CLEARANCE FROM PHASE 5 (HEADS 51.52).

LOGIC I/O PROCESSOR PROGRAMMING COMPLETE

OUTPUT REFERENCE SCHEDULE	
USE TO INTERPRET LOGIC PROCESSOR	
OUTPUT 42 =	Overlap C Red
OUTPUT 43 =	Overlap C Yellow
OUTPUT 44 =	Overlap C Green

**OVERLAP PROGRAMMING DETAIL
FOR DEFAULT PHASING**
(program controller as shown below)

FROM MAIN MENU PRESS '8' (OVERLAPS), THEN '1' (VEHICLE OVERLAP SETTINGS).

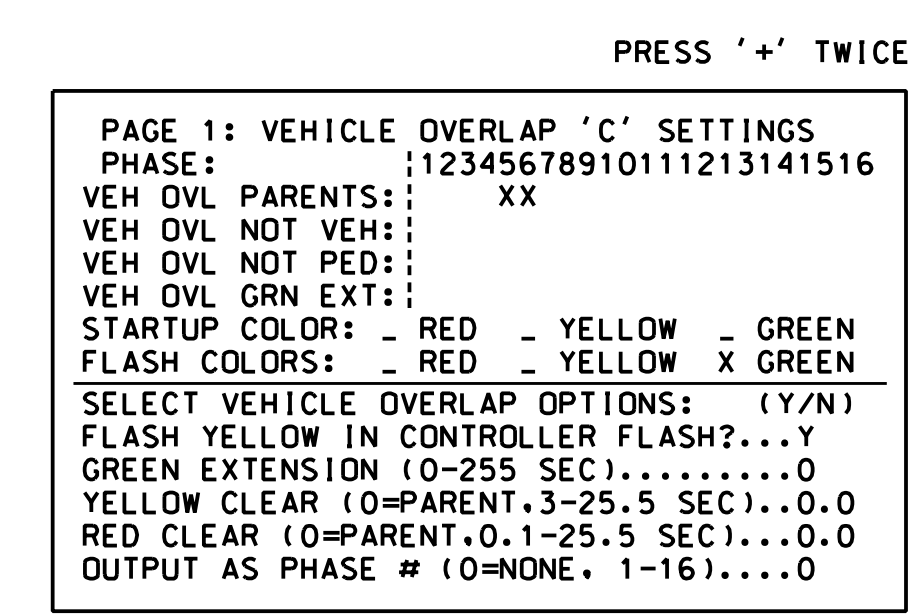

← NOTICE GREEN FLASH

OVERLAP PROGRAMMING COMPLETE

**OVERLAP PROGRAMMING DETAIL
FOR ALTERNATE PHASING**
(program controller as shown below)

FROM MAIN MENU PRESS '8' (OVERLAPS), THEN '1' (VEHICLE OVERLAP SETTINGS). PRESS 'NEXT' TO ADVANCE TO PAGE 2.

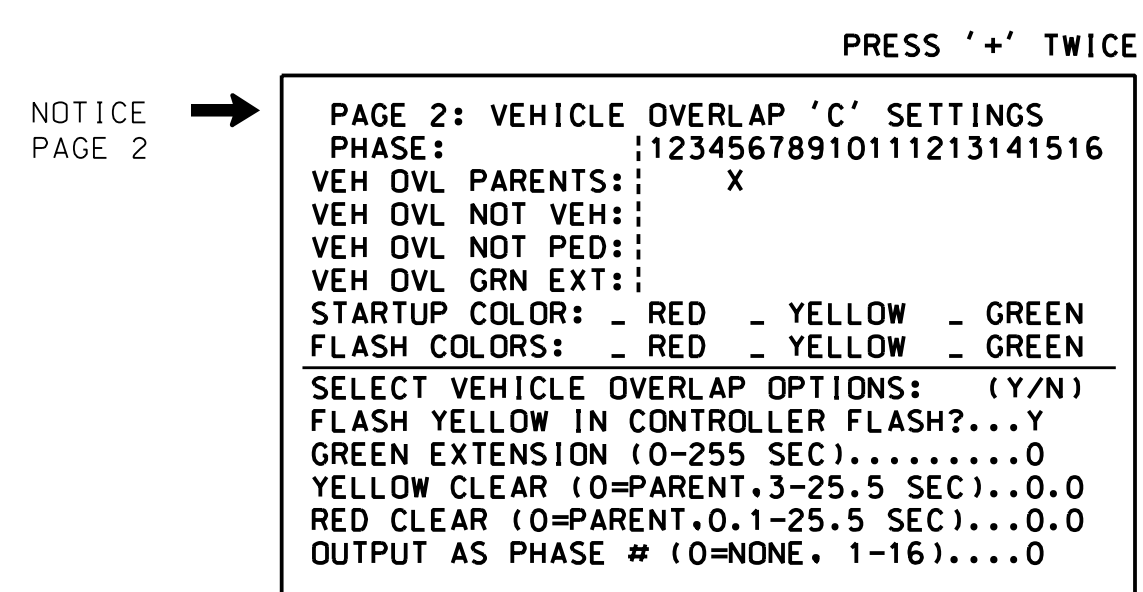

→ NOTICE PAGE 2

OVERLAP PROGRAMMING COMPLETE

THIS ELECTRICAL DETAIL IS FOR THE SIGNAL DESIGN: 03-1123
DESIGNED: June 2017
SEALED: 9/10/2021
REVISED: N/A

Electrical Detail - Sheet 2 of 4
New Installation
Final Design

**DOCUMENT NOT CONSIDERED FINAL
UNLESS ALL SIGNATURES COMPLETED**

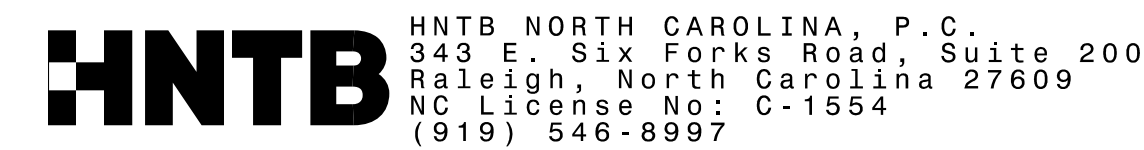

	Prepared for: NC 906 (Middleton Boulevard) at NC 211 Southbound Ramp	
	Division 03 Brunswick Co. Southport PLAN DATE: June 2017 REVIEWED BY: A.D. Klinksiek PREPARED BY: A.H. Thornburg REVIEWED BY: N.R. Simmons	
REVISIONS _____ _____ _____	INIT. DATE _____ _____ _____	Signature: <i>Natasha Simmons</i> DATE: 9/10/2021 SIGNATURE DATE _____ _____

INPUT PAGE 2 ASSIGNMENT PROGRAMMING DETAIL FOR ALTERNATE PHASING - LOOP 5A

(program controller as shown below)

- NOTES: 1. THIS PROGRAMMING APPLIES FOR INPUT PAGE 2 ONLY. INPUT PAGE 1 WILL USE STANDARD DEFAULT SETTINGS. THIS PROGRAMMING IS NECESSARY FOR PROPER DETECTOR OPERATION DURING ALTERNATE PHASING OPERATION.
2. THE TASK THIS PROGRAMMING ACCOMPLISHES IS THAT IT REASSIGNS DETECTOR 55 TO INPUT #17 SO THAT THE DELAY ON LOOP 5A CAN BE REDUCED FROM 15 SECONDS TO 0 SECONDS.

FROM MAIN MENU PRESS '5' (INPUTS), THEN PRESS 'NEXT' TO GET TO INPUT PAGE '2'. PRESS THE '+' KEY UNTIL INPUT 17 IS REACHED.

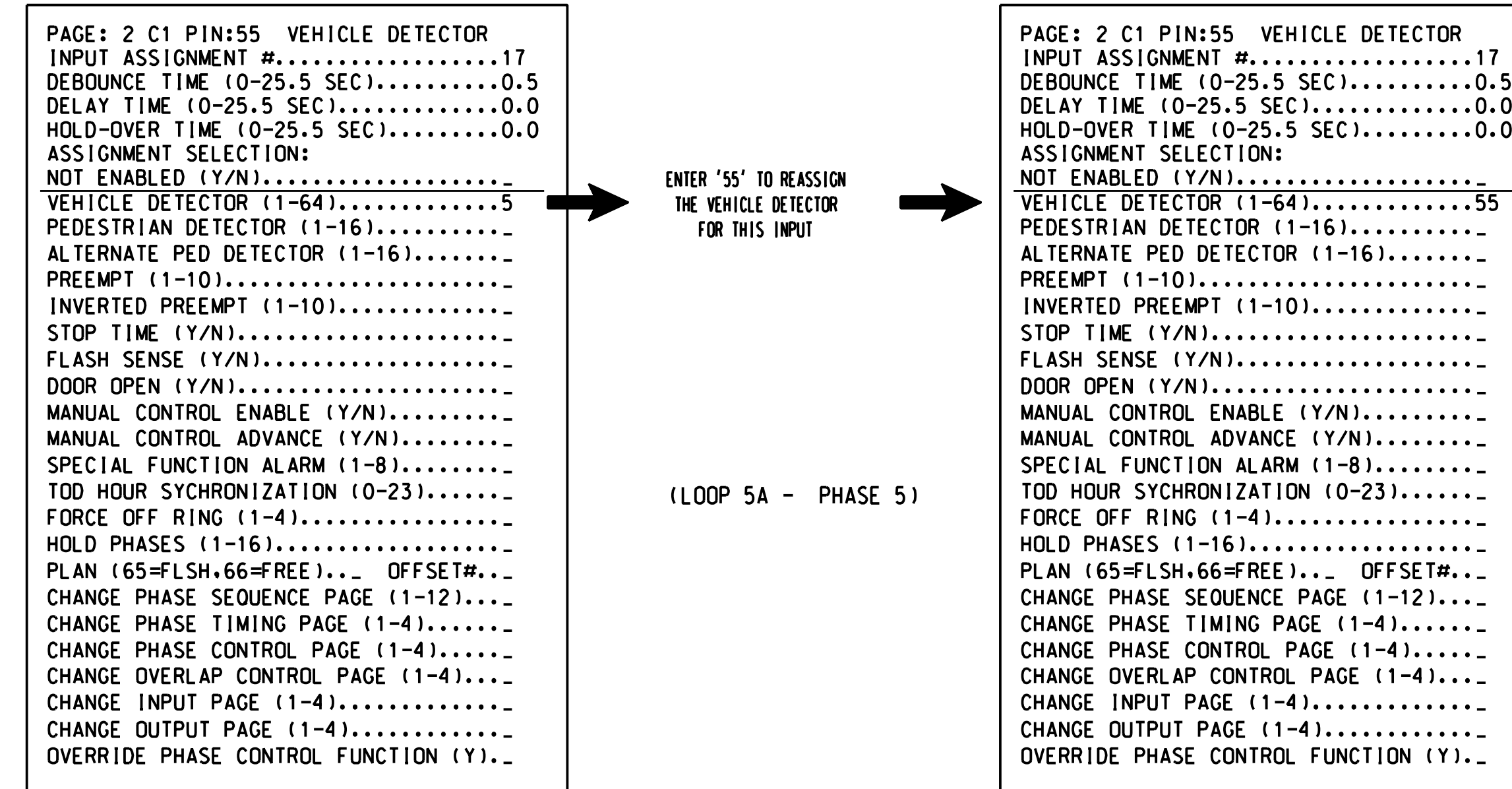

PROGRAMMING COMPLETE

SPECIAL DETECTOR PROGRAMMING DETAIL - LOOP 5A (ALT.)

(program controller as shown below)

FROM MAIN MENU PRESS '7' (DETECTORS), THEN PRESS '1' FOR VEHICLE DETECTORS. PRESS THE '-' KEY TO GET TO VEHICLE DETECTOR #55.

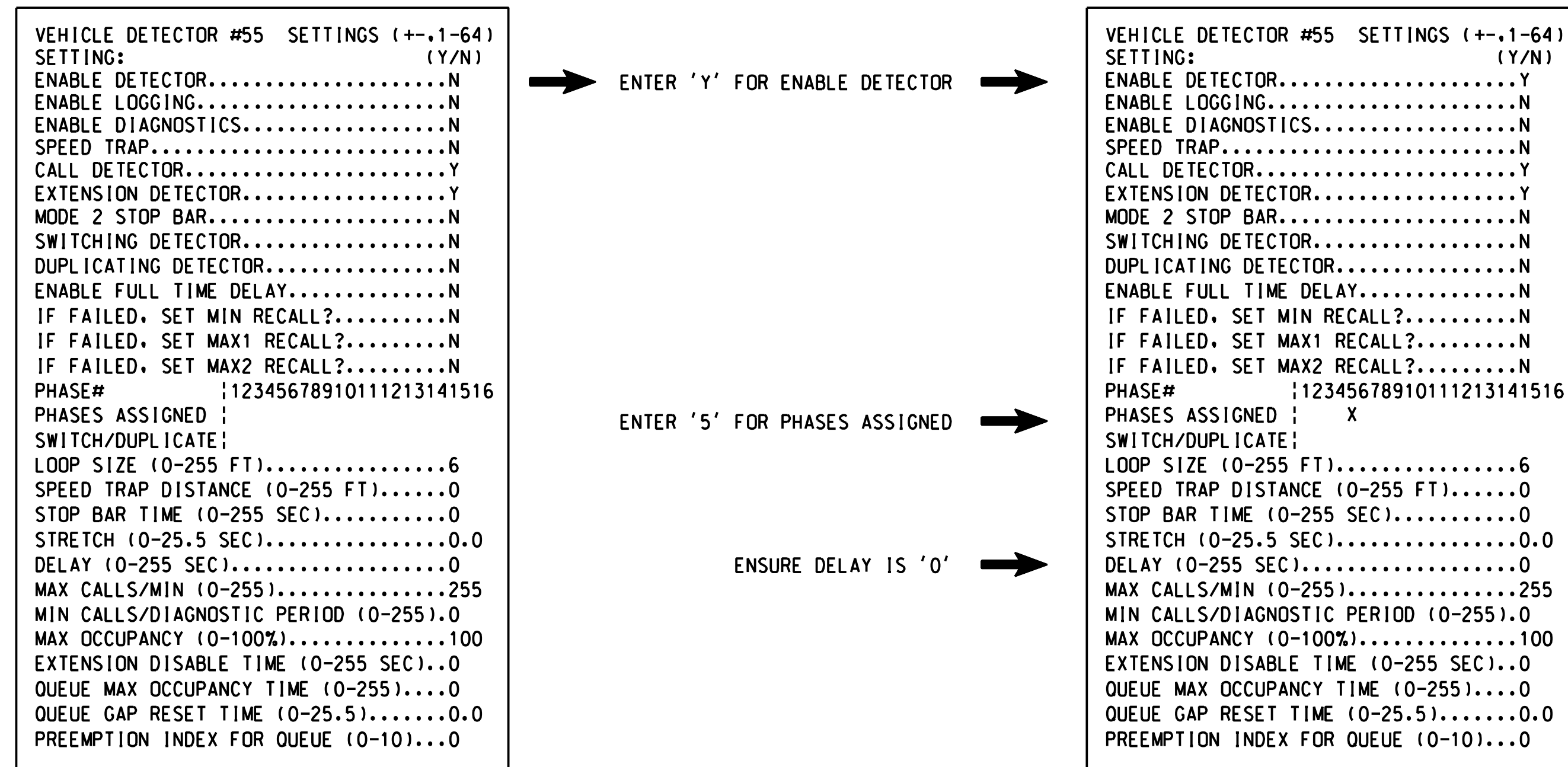

DETECTOR PROGRAMMING COMPLETE

NOTE: DETECTOR IS PROGRAMMED PER THE INPUT FILE CONNECTION AND PROGRAMMING CHART SHOWN ON SHEET 1.

THIS ELECTRICAL DETAIL IS FOR THE SIGNAL DESIGN: 03-1123
 DESIGNED: June 2017
 SEALED: 9/10/2021
 REVISED: N/A

Electrical Detail - Sheet 3 of 4
 New Installation
 Final Design

DOCUMENT NOT CONSIDERED FINAL UNLESS ALL SIGNATURES COMPLETED

	Prepared for: Department of Transportation North Carolina		
	Prepared for: NC 906 (Middleton Boulevard) at NC 211 Southbound Ramp		
Division 03 Brunswick Co. Southport		PLAN DATE: June 2017 REVIEWED BY: A.D. Klinksiek	
PREPARED BY: A.H. Thornburg REVIEWED BY: N.R. Simmons		REVISIONS: _____ INITI. DATE _____	
750 N. Greenfield Pkwy, Corner, NC 27529		Signature: _____ Date: 9/10/2021	

HNTB HNTB NORTH CAROLINA, P.C.
 343 E. Six Forks Road, Suite 200
 Raleigh, North Carolina 27609
 NC License No: C-1554
 (919) 546-8997

ALTERNATE PHASING ACTIVATION DETAIL

TO RUN ALT. PHASING DURING COORDINATION - SELECT ALL PAGE CHANGES (AS SHOWN BELOW) WITHIN COORDINATION PLAN PROGRAMMING.

TO RUN ALT. PHASING DURING FREE RUN - PROGRAM PAGE CHANGES (SHOWN BELOW) IN SEPARATE TIME OF DAY EVENTS. IF PAGE 1 IS USED, NO EVENT PROGRAMMING IS NECESSARY FOR THAT PARTICULAR PAGE.

<u>PHASING</u>	<u>INPUTS PAGE</u>	<u>OVERLAPS PAGE</u>
ACTIVE PAGES REQUIRED TO RUN <u>DEFAULT PHASING</u>	1	1
ACTIVE PAGES REQUIRED TO RUN <u>ALTERNATE PHASING</u>	2	2

NOTE: PAGES NOT SHOWN (i.e. sequence, phase control, etc.) SHOULD REMAIN AS '1', OR AS DEFINED BY TIMING ENGINEER.

IMPORTANT: IF ALT. PHASING IS USED DURING FREE RUN AND COORDINATION, DO NOT OPERATE TIME OF DAY PAGE CHANGE EVENTS CONCURRENTLY WITH COORDINATION PLAN EVENTS IN THE EVENT SCHEDULER. (EX. FREE RUN PAGE CHANGE EVENT SHOULD END BEFORE COORDINATION PLAN EVENT STARTS AND VICE-VERSA).

ALTERNATE PHASING PAGE CHANGE SUMMARY

THE FOLLOWING IS A SUMMARY OF WHAT TAKES PLACE WHEN THESE OVERLAP/INPUT PAGE CHANGES ACTIVATE TO CALL THE "ALTERNATE PHASING":

OVERLAPS PAGE 2: Modifies overlap parent phases for heads 51.52 to run protected turns only.

INPUTS PAGE 2: Reduces delay time for phase 5 call on loop 5A to 0 seconds.

THIS ELECTRICAL DETAIL IS FOR THE SIGNAL DESIGN: 03-1123
DESIGNED: June 2017
SEALED: 9/10/2021
REVISED: N/A

Electrical Detail - Sheet 4 of 4
New Installation
Final Design

**DOCUMENT NOT CONSIDERED FINAL
UNLESS ALL SIGNATURES COMPLETED**

HNTB HNTB NORTH CAROLINA, P.C.
343 E. Six Forks Road, Suite 200
Raleigh, North Carolina 27609
NC License No: C-1554
(919) 546-8997

<p style="font-size: small;">ELECTRICAL AND PROGRAMMING DETAILS FOR:</p> <p style="font-size: x-small;">Prepared for: 750 N. Greenfield Pkwy, Corner, NC 27529</p>	<p>NC 906 (Middleton Boulevard) at NC 211 Southbound Ramp</p> <p style="font-size: x-small;">Division 03 Brunswick Co. Southport</p> <p style="font-size: x-small;">PLAN DATE: June 2017 REVIEWED BY: A.D. Klinksiek</p> <p style="font-size: x-small;">PREPARED BY: A.H. Thornburg REVIEWED BY: N.R. Simmons</p>	<p style="text-align: center;">SEAL</p> <p style="text-align: center;"></p> <p style="font-size: x-small;">DocuSigned by: Natasha Simmons 9/10/2021</p>												
<table border="1" style="width: 100%; border-collapse: collapse;"> <thead> <tr> <th style="font-size: x-small;">REVISIONS</th> <th style="font-size: x-small;">INIT.</th> <th style="font-size: x-small;">DATE</th> </tr> </thead> <tbody> <tr> <td> </td> <td> </td> <td> </td> </tr> <tr> <td> </td> <td> </td> <td> </td> </tr> <tr> <td> </td> <td> </td> <td> </td> </tr> </tbody> </table>		REVISIONS	INIT.	DATE										<p style="font-size: x-small;">SIGNATURE DATE</p> <p style="font-size: x-small;">SIG. INVENTORY NO. 03-1123</p>
REVISIONS	INIT.	DATE												

Design Loading for METAL POLE NO. 1

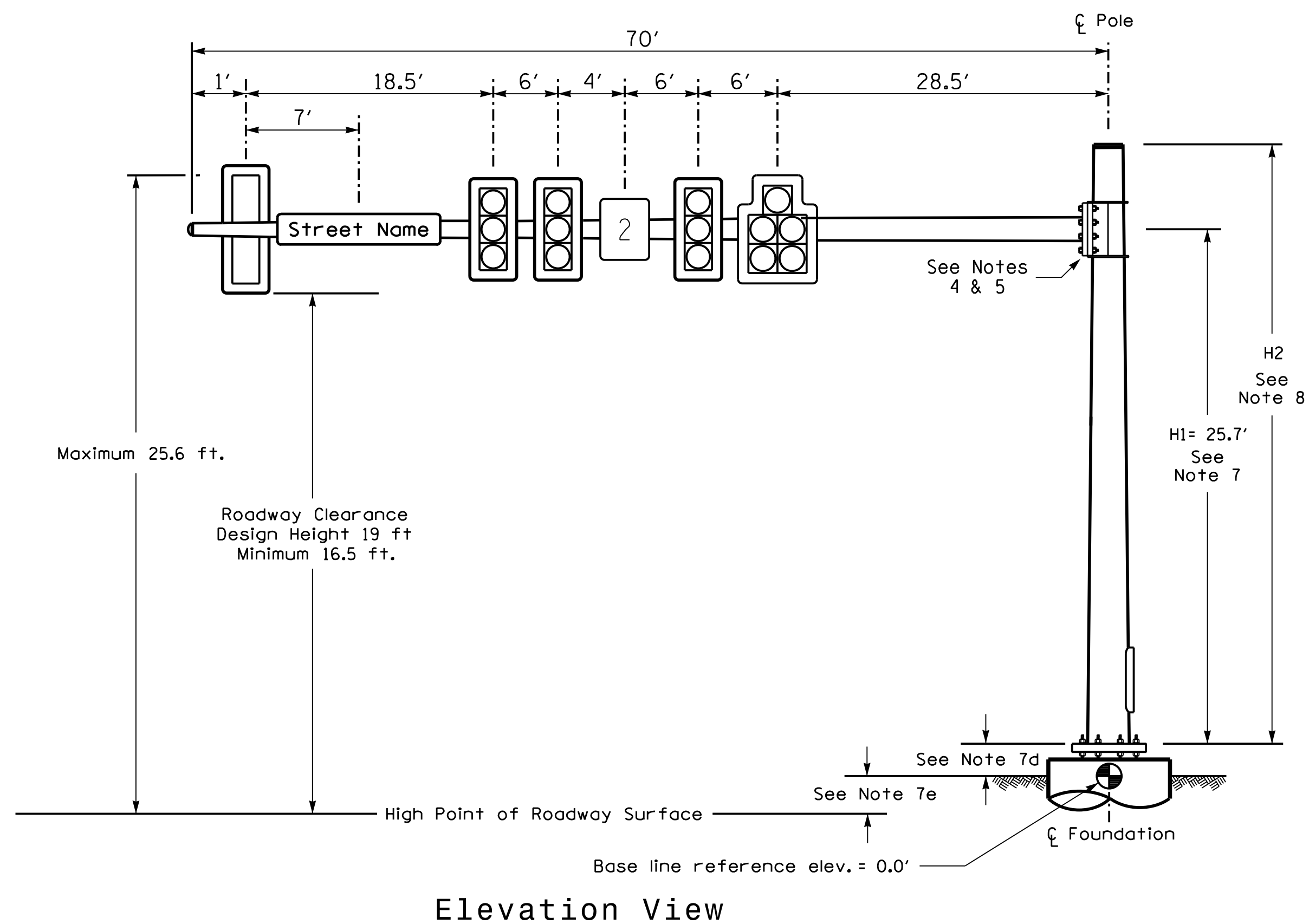

SPECIAL NOTE
The contractor is responsible for verifying that the mast arm attachment height (H1) will provide the "Design Height" clearance from the roadway before submitting final shop drawings for approval. Verify elevation data below which was obtained by field measurement or from available project survey data.

Elevation Data for Mast Arm Attachment (H1)

Elevation Differences for:	Pole 1	
Baseline reference point at \odot Foundation @ ground level	0.0 ft.	
Elevation difference at High point of roadway surface	+4.67 ft.	
Elevation difference at Edge of travelway or face of curb	+4.63 ft.	

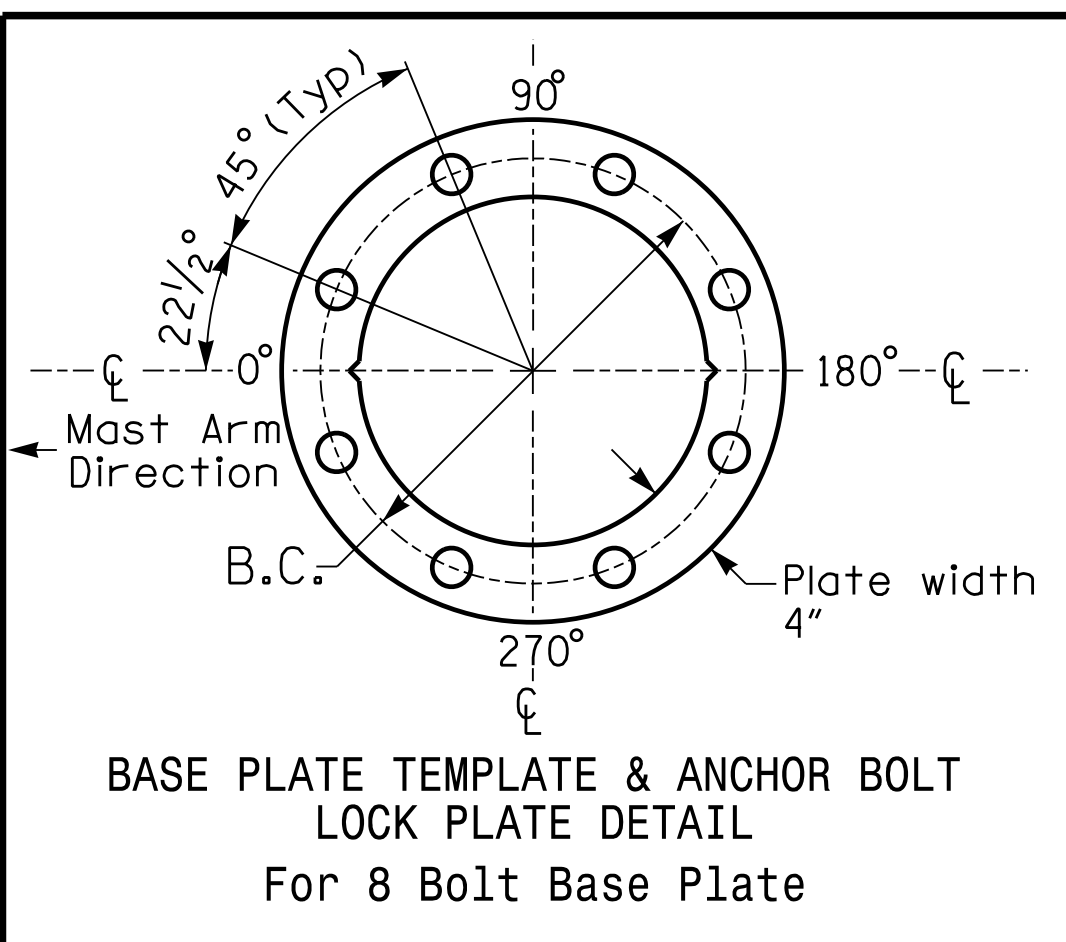
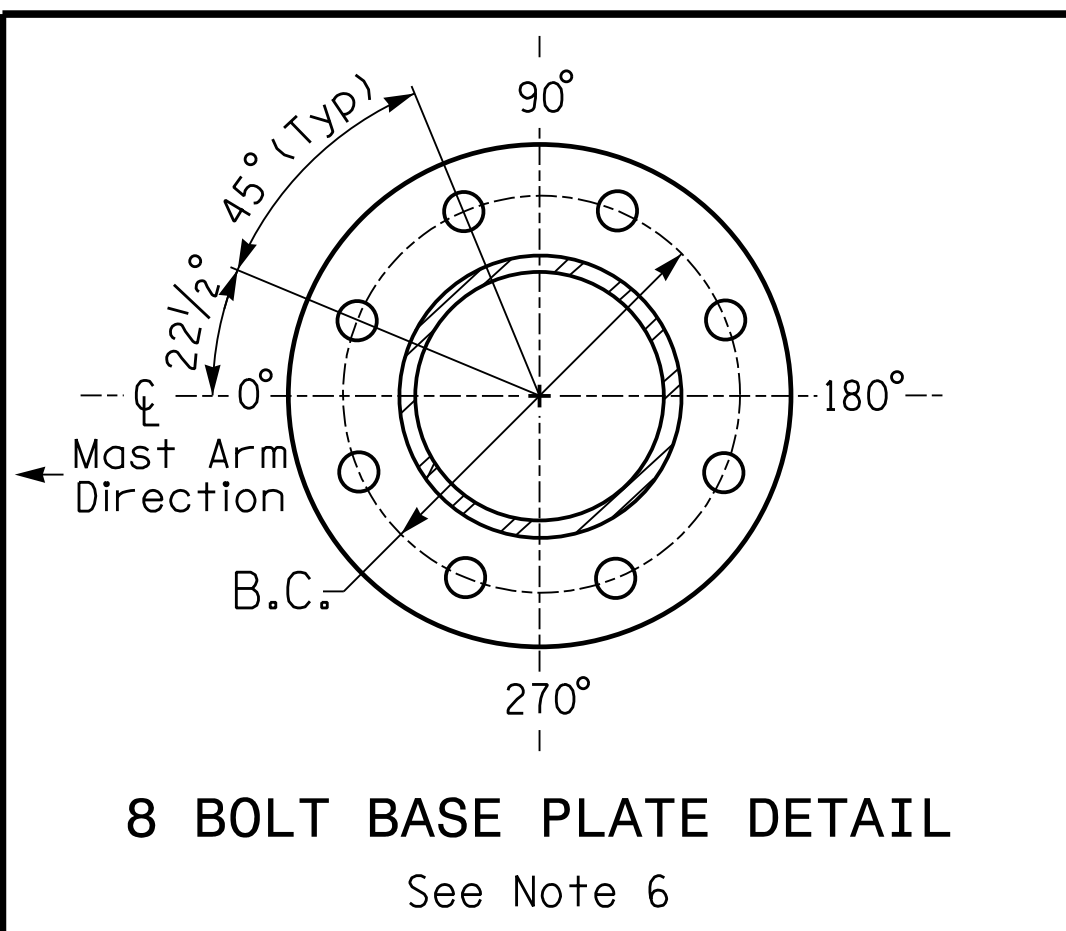
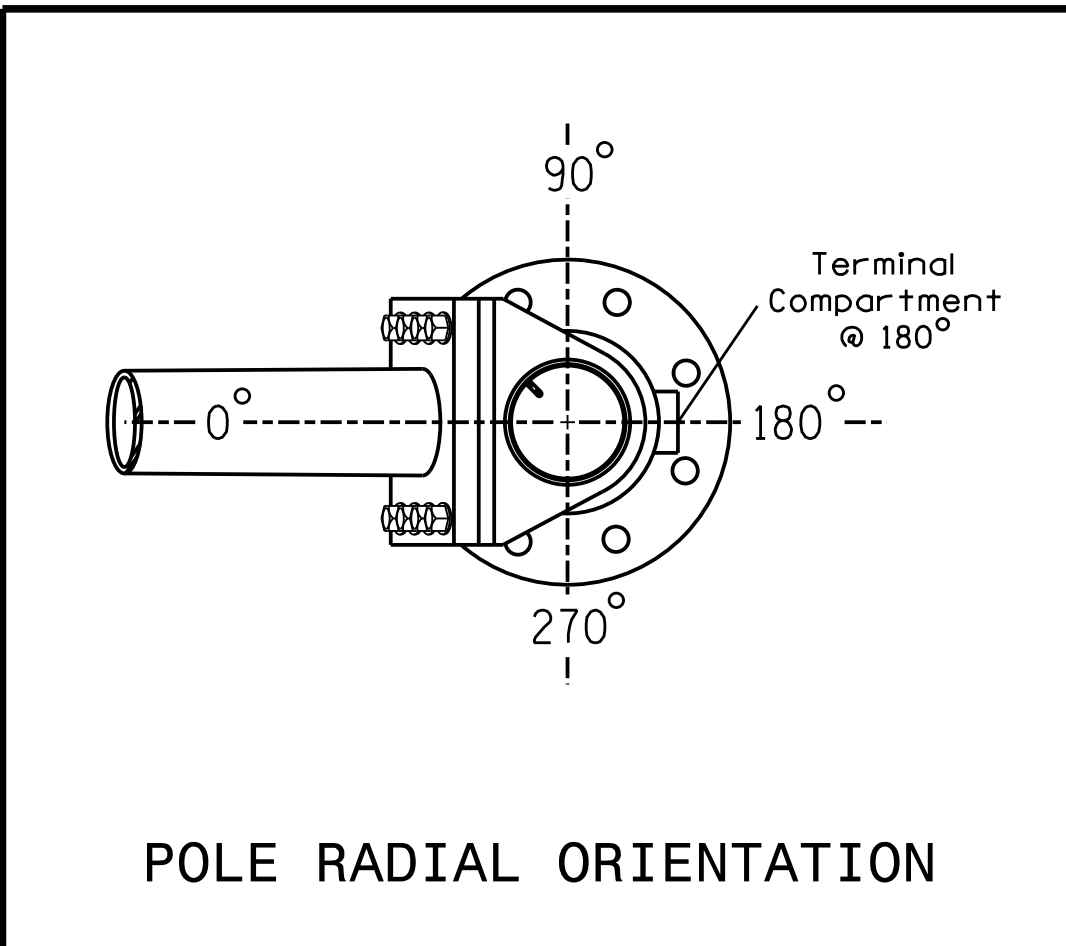

HNTB HNTB NORTH CAROLINA, P.C.
343 E. Six Forks Road, Suite 200
Raleigh, North Carolina 27609
NC License No: C-1554
(919) 546-8997

METAL POLE No. 1

PROJECT REFERENCE NO.	SHEET NO.
R-5021	Sig. 6.5

MAST ARM LOADING SCHEDULE

LOADING SYMBOL	DESCRIPTION	AREA	SIZE	WEIGHT
	RIGID MOUNTED SIGNAL HEAD 12"-3 SECTION-WITH BACKPLATE	9.3 S.F.	25.5" W X 52.5" L	60 LBS
	RIGID MOUNTED SIGNAL HEAD 12"-4 SECTION-WITH BACKPLATE	11.5 S.F.	25.5" W X 66.0" L	74 LBS
	RIGID MOUNTED SIGNAL HEAD 12"-5 SECTION-WITH BACKPLATE	16.3 S.F.	42.0" W X 56.0" L	103 LBS
	SIGN RIGID MOUNTED	7.5 S.F.	30.0" W X 36.0" L	14 LBS
	STREET NAME SIGN RIGID MOUNTED	16.0 S.F.	24.0" W X 96.0" L	36 LBS

NOTES

DESIGN REFERENCE MATERIAL

- Design the traffic signal structure and foundation in accordance with:
 - The 6th Edition 2013 AASHTO "Standard Specifications for Structural Supports for Highway Signs, Luminaires, and Traffic Signals, including all of the latest interim revisions.
 - The 2018 NCDOT "Standard Specifications for Roads and Structures." The latest addenda to the specifications can be found in the traffic signal project special provisions.
 - The 2018 NCDOT Roadway Standard Drawings.
 - The traffic signal project plans and special provisions.
 - The NCDOT "Metal Pole Standards" located at the following NCDOT website: <https://connect.ncdot.gov/resources/safety/Pages/ITS-Design-Resources.aspx>

DESIGN REQUIREMENTS

- Design the traffic signal structure using the loading conditions shown in the elevation views. These are anticipated worst case "design loads" and may not represent the actual loads that will be applied at the time of the installation. The contractor should refer to the traffic signal plans for the actual loads that will be applied at the time of the installation.
- Design all signal supports using stress ratios that do not exceed 0.9.
- The camber design for the mast arm deflection should provide an appearance of a low pitched arch where the tip or the free end of the mast arm does not deflect below horizontal when fully loaded.
- A clamp-type bolted mast arm-to-pole connection may be used instead of the welded ring stiffened box connection shown as long as the connection meets all of the design requirements.
- Design base plate with 8 anchor bolt holes. Provide 2 inch x 60 inch anchor bolts.
- The mast arm attachment height (H1) shown is based on the following design assumptions:
 - Mast arm slope and deflection are not considered in determining the arm attachment height as they are assumed to offset each other.
 - Signal heads are rigidly mounted and vertically centered on the mast arm.
 - The roadway clearance height for design is as shown in the elevation views.
 - The top of the pole base plate is 0.75 feet above the ground elevation.
 - Refer to the Elevation Data Chart for the elevation differences between the proposed foundation ground level and the high point of the roadway.
- The pole manufacturer will determine the total height (H2) of each pole using the greater of the following:
 - Mast arm attachment height (H1) plus 2 feet, or
 - H1 plus 1/2 of the total height of the mast arm attachment assembly plus 1 foot.
- If pole location adjustments are required, the contractor must gain approval from the Engineer as this may affect the mast arm lengths and arm attachment heights. The contractor may contact the Signal Design Section Senior Structural Engineer for assistance at (919) 814-5000.
- The contractor is responsible for verifying that the mast arm length shown will allow proper positioning of the signal heads over the roadway.
- The contractor is responsible for providing soil penetration testing data (SPT) to the pole manufacturer so site specific foundations can be designed.

NCDOT Wind Zone 2 (130 mph)

DOCUMENT NOT CONSIDERED FINAL UNLESS ALL SIGNATURES COMPLETED

	NC 906 (Middleton Boulevard) at NC 211 Southbound Ramp Division 03 Brunswick Co. Southport PLAN DATE: June 2017 REVIEWED BY: A.D. Klinsky PREPARED BY: A.H. Thornburg REVIEWED BY: N.R. Simmons	
	SCALE: 0 N/A N/A	

9/10/2021
DATE
SIG. INVENTORY NO. 03-1123

DEFAULT PHASING DIAGRAM

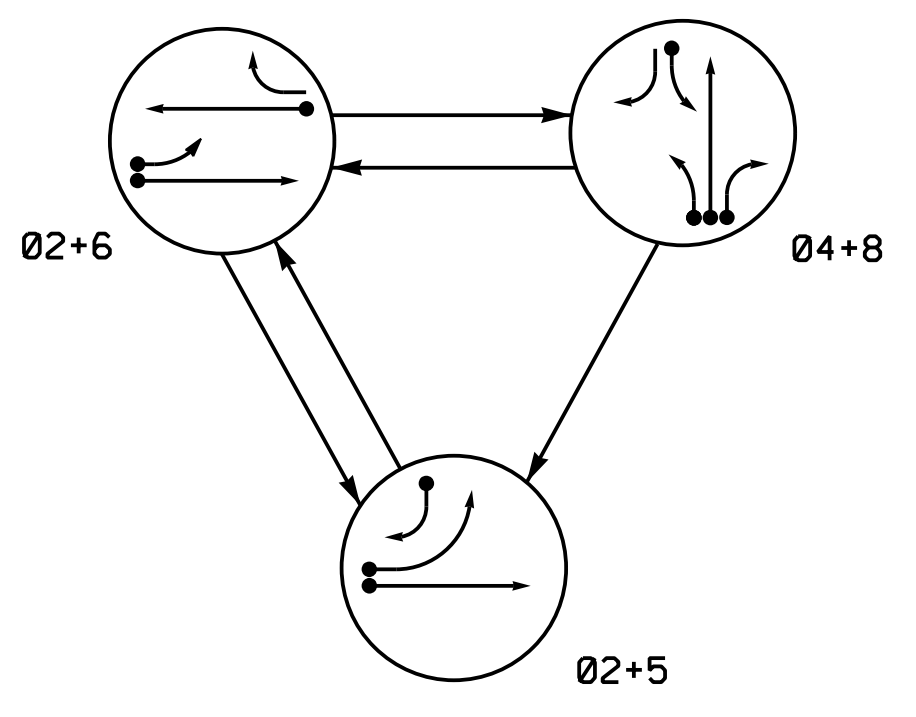

ALTERNATE PHASING DIAGRAM

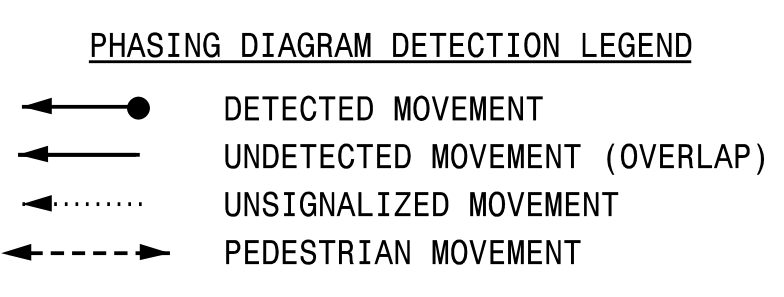
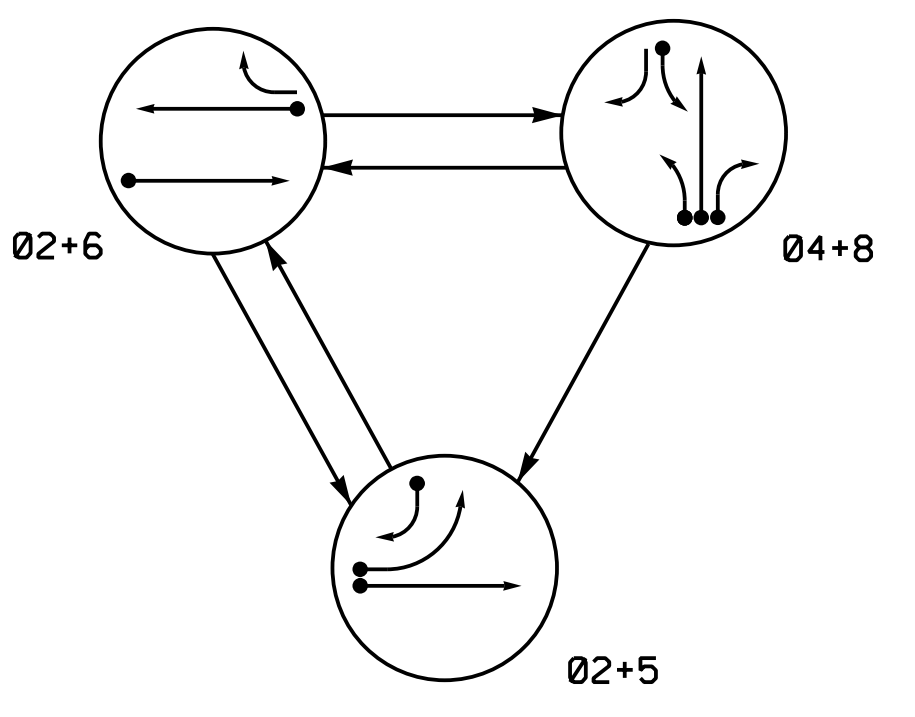

DEFAULT PHASING TABLE OF OPERATION

SIGNAL FACE	PHASE				
	02+5	02+6	04+8	F	P
21,22	G	G	R	Y	
41	R	R	G	R	
42	R	R	G	R	
51	-	-	-	-	-
61,62	R	G	R	Y	
81,82	R	R	G	R	

ALTERNATE PHASING TABLE OF OPERATION

SIGNAL FACE	PHASE				
	02+5	02+6	04+8	F	P
21,22	G	G	R	Y	
41	R	R	G	R	
42	R	R	G	R	
51	-	-	-	-	-
61,62	R	G	R	Y	
81,82	R	R	G	R	

OASIS 2070 LOOP & DETECTOR INSTALLATION CHART

LOOP	SIZE (FT)	DISTANCE FROM STOPBAR (FT)	TURNS	NEW LOOP	DETECTOR PROGRAMMING					SYSTEM LOOP	NEW CARD	
					PHASE	CALLING	EXTENSION	FULL TIME DELAY	STRETCH TIME			DELAY TIME
2A	6X6	300	*	*	2	Y	Y	-	-	-	-	Y
4A	6X40	0	*	*	4	Y	Y	-	-	-	-	Y
5A	6X40	0	*	*	5	Y	Y	-	-	***15	-	Y
5B	6X40	0	*	*	5	Y	Y	-	-	15	-	Y
6A	6X6	300	*	*	6	Y	Y	-	-	-	-	Y
8A	6X40	0	*	*	8	Y	Y	-	-	-	-	Y
8B	6X40	0	*	*	8	Y	Y	-	-	-	-	Y
8C	6X40	0	*	*	8	Y	Y	-	-	15	-	Y

* Multizone Microwave Detection.
 ** Disable phase 2 call for 5A during alternate phasing operation.
 *** Reduce delay to 3 seconds during alternate phasing operation.

3 Phase Fully Actuated Isolated

NOTES

1. Refer to "Roadway Standard Drawings NCDOT" dated January 2018 and "Standard Specifications for Roads and Structures" dated January 2018.
2. Do not program signal for late night flashing operation unless otherwise directed by the Engineer.
3. Phase 5 may be lagged.
4. Set all detector units to presence mode.
5. Locate new cabinet so as to not obstruct sight distance of vehicles turning right on red.
6. The Division Traffic Engineer will determine the hours of use for each phasing plan.
7. Incorporate Microwave Detection system for vehicle detection.
8. Provide the Engineer with the Manufacturer's approved Microwave Detection locations and mounting heights to obtain detection zones as shown.

SIGNAL FACE I.D.

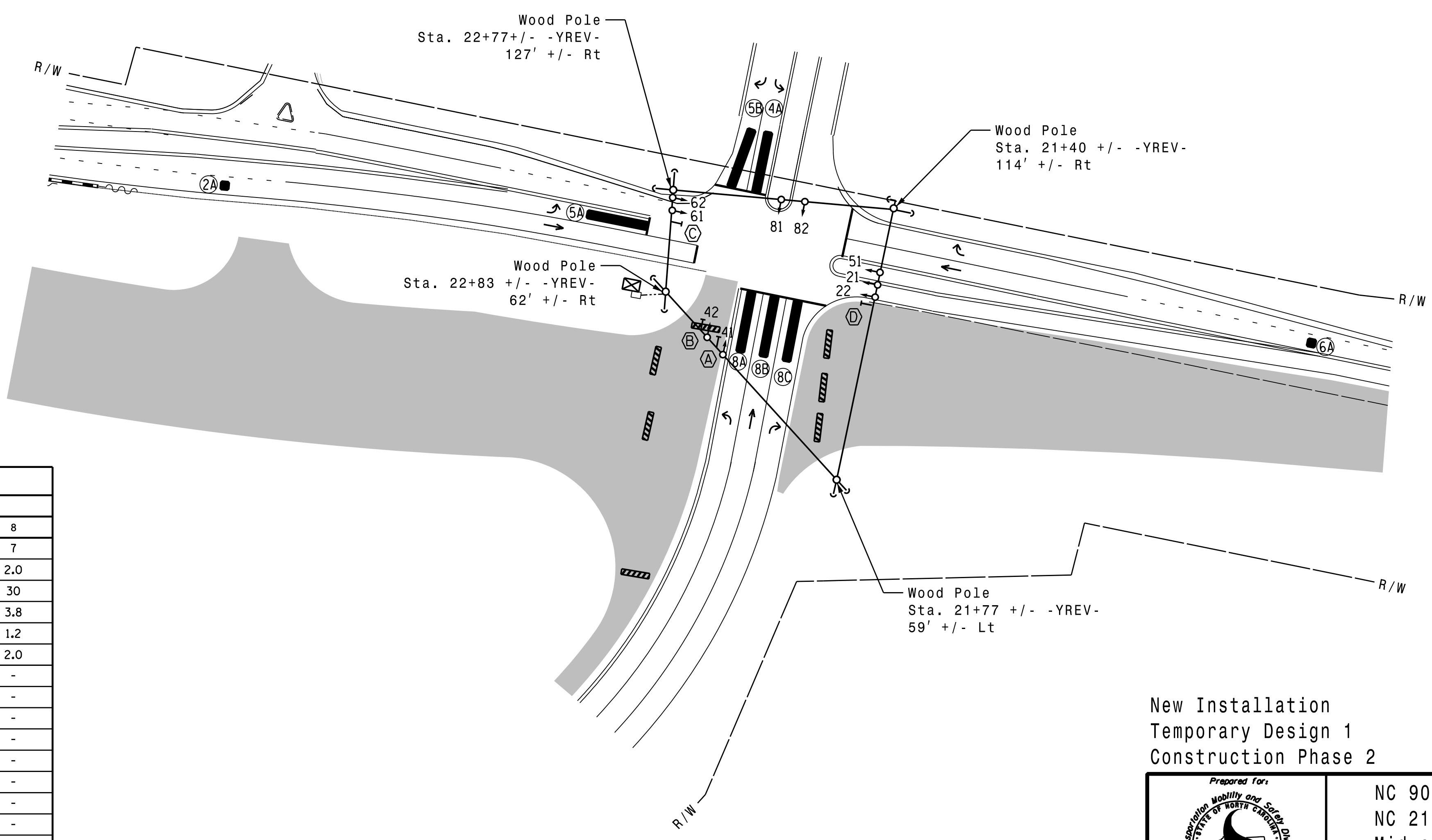
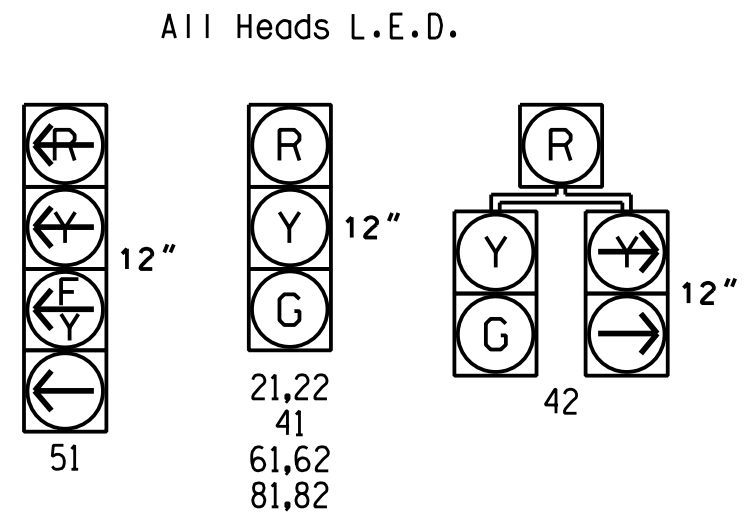

OASIS 2070 TIMING CHART

FEATURE	PHASE				
	2	4	5	6	8
Min Green 1 *	12	7	7	12	7
Extension 1 *	6.0	2.0	2.0	6.0	2.0
Max Green 1 *	60	30	20	60	30
Yellow Clearance	4.9	3.1	3.0	4.9	3.8
Red Clearance	1.4	2.3	3.3	1.4	1.2
Red Revert	2.0	2.0	2.0	2.0	2.0
Walk 1 *	-	-	-	-	-
Don't Walk 1	-	-	-	-	-
Seconds Per Actuation *	2.5	-	-	2.5	-
Max Variable Initial *	34	-	-	34	-
Time Before Reduction *	15	-	-	15	-
Time To Reduce *	30	-	-	30	-
Minimum Gap	3.0	-	-	3.0	-
Recall Mode	MIN RECALL	-	-	MIN RECALL	-
Vehicle Call Memory	YELLOW	-	-	YELLOW	-
Dual Entry	-	ON	-	-	ON
Simultaneous Gap	ON	ON	ON	ON	ON

* These values may be field adjusted. Do not adjust Min Green and Extension times for phases 2 and 6 lower than what is shown. Min Green for all other phases should not be lower than 4 seconds.

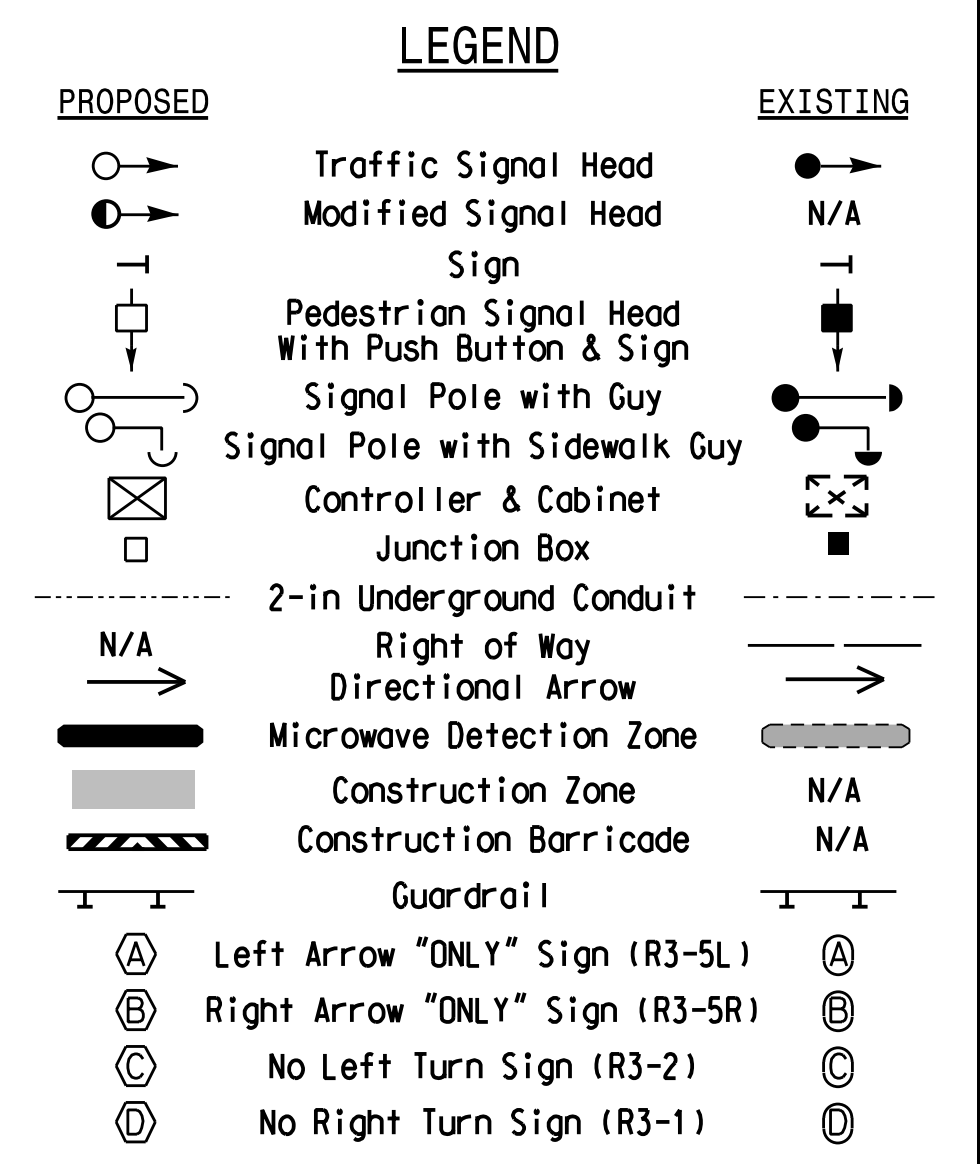

New Installation
 Temporary Design 1
 Construction Phase 2

DOCUMENT NOT CONSIDERED FINAL UNLESS ALL SIGNATURES COMPLETED

	Prepared for: TRANSPORTATION MOBILITY AND SAFETY DIVISION NORTH CAROLINA DEPARTMENT OF TRANSPORTATION SIGNAL DESIGN SECTION 750 N. Greenfield Pkwy, Garner, NC 27526	NC 906 (Midway Road) at NC 211 Northbound Ramp/ Midway Commons Driveway Division 03 Brunswick Co. Southport PLAN DATE: June 2017 REVIEWED BY: A.D. Klinksiek PREPARED BY: A.H. Thornburg REVIEWED BY: N.R. Simmons	SEAL
	HNTB NORTH CAROLINA, P.C. 343 E. Six Forks Road, Suite 200 Raleigh, North Carolina 27609 NC License No: C-1554 (919) 546-8997	SCALE 0 50 1" = 50'	REVISIONS INIT. DATE SIGNATURE DATE 9/10/2021 SIG. INVENTORY NO. 03-1122T1

EDI MODEL 2018ECL-NC CONFLICT MONITOR PROGRAMMING DETAIL

(remove jumpers and set switches as shown)

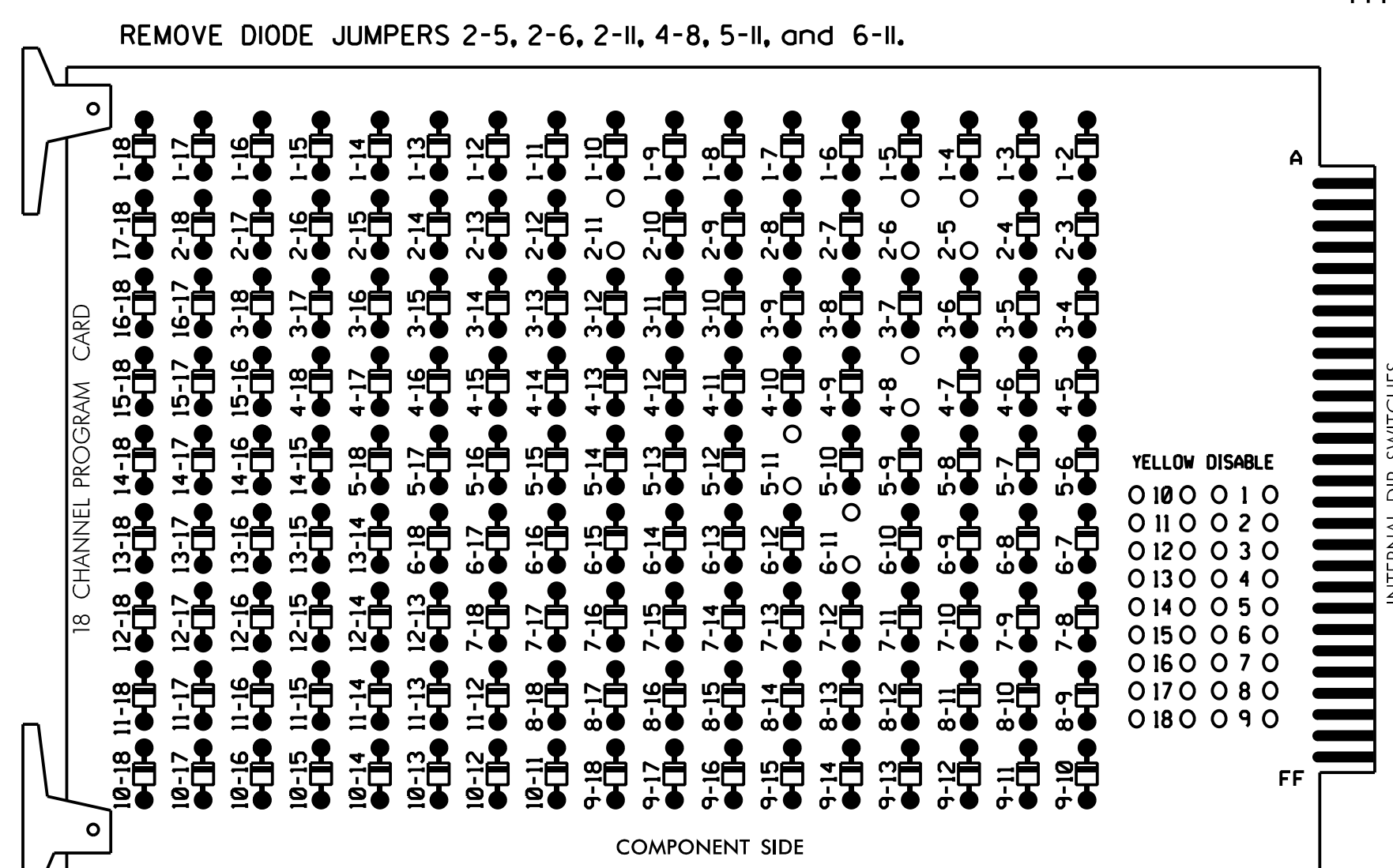

- NOTES:**
- Card is provided with all diode jumpers in place. Removal of any jumper allows its channels to run concurrently.
 - Ensure jumpers SEL2-SEL5 and SEL9 are present on the monitor board.
 - Ensure that Red Enable is active at all times during normal operation.
 - Connect serial cable from conflict monitor to comm. port 1 of 2070 controller. Ensure conflict monitor communicates with 2070.

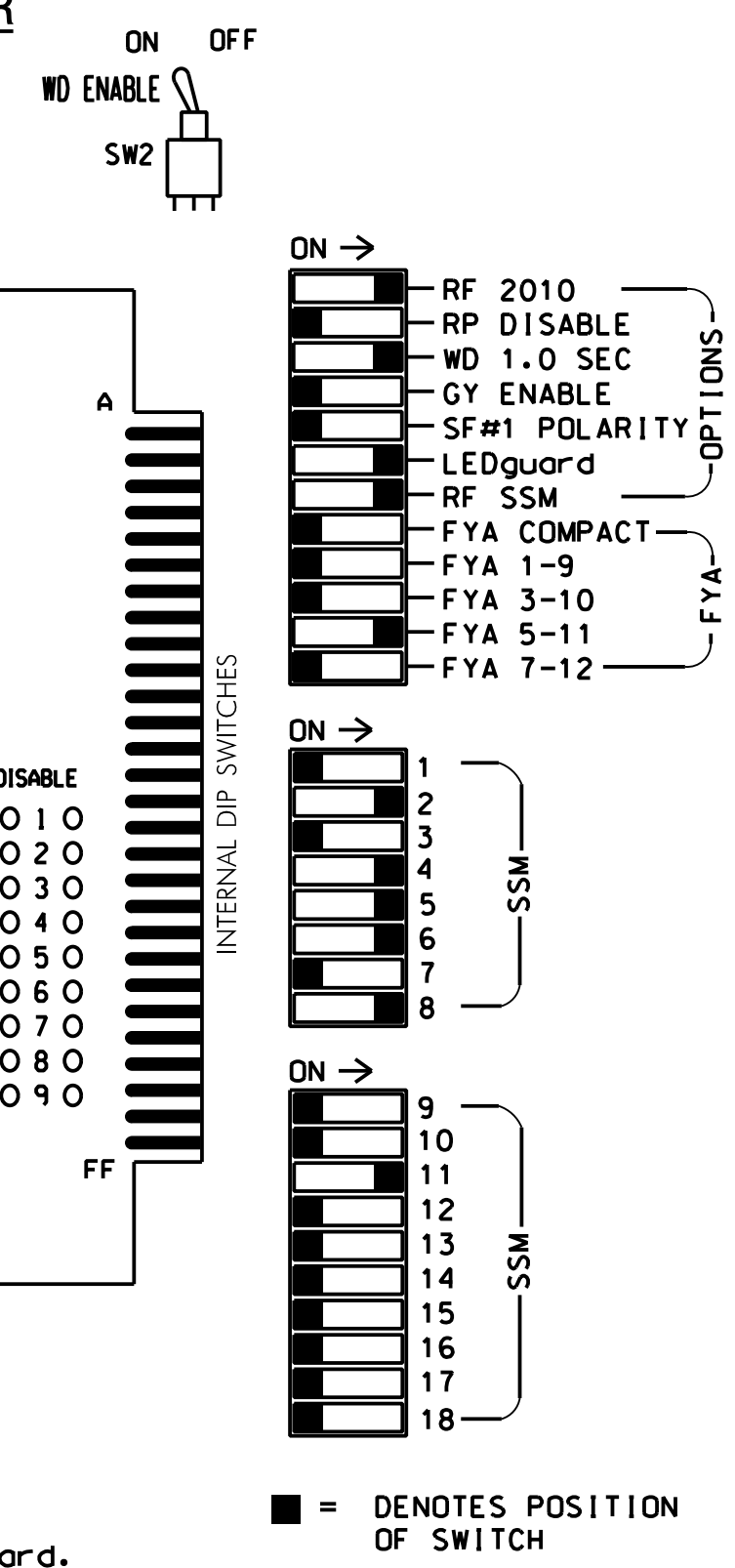

NOTES

- To prevent "flash-conflict" problems, insert red flash program blocks for all unused vehicle load switches in the output file. The installer shall verify that signal heads flash in accordance with the Signal Plans.
- Program phases 4 and 8 for Dual Entry.
- Enable Simultaneous Gap-Out for all Phases.
- Program phases 2 and 6 for Variable Initial and Gap Reduction.
- Program phases 2 and 6 for Startup In Green.
- Program phases 2 and 6 for Yellow Flash, and overlap 1 as Wag Overlaps.
- If this signal will be managed by an ATMS software, enable controller and detector logging for all detectors used at this location.

EQUIPMENT INFORMATION

CONTROLLER.....2070E
 CABINET.....332 W/AUX
 SOFTWARE.....ECONOLITE OASIS
 CABINET MOUNT.....BASE
 OUTPUT FILE POSITIONS...18 WITH AUX. OUTPUT FILE
 LOAD SWITCHES USED.....S2,S5,S7,S8,S11,AUX S4
 PHASES USED.....2,4,5,6,8
 OVERLAP "A".....NOT USED
 OVERLAP "B".....NOT USED
 OVERLAP "C".....5+6
 OVERLAP "D".....NOT USED

SIGNAL HEAD HOOK-UP CHART

LOAD SWITCH NO.	S1	S2	S3	S4	S5	S6	S7	S8	S9	S10	S11	S12	AUX S1	AUX S2	AUX S3	AUX S4	AUX S5	AUX S6	
CMU CHANNEL NO.	1	2	13	3	4	14	5	6	15	7	8	16	9	10	17	11	12	18	
PHASE	1	2	2 PED	3	4	4 PED	5	6	6 PED	7	8	8 PED	OLA	OLB	SPARE	OLC	OLD	SPARE	
SIGNAL HEAD NO.	NU	21,22	NU	NU	41,42	NU	42	51	61,62	NU	NU	81,82	NU	NU	NU	51	NU	NU	
RED		128			101		*		134			107							
YELLOW		129			102				135			108							
GREEN		130			103				136			109							
RED ARROW																		A114	
YELLOW ARROW								132											A115
FLASHING YELLOW ARROW																			A116
GREEN ARROW							133	133											

NU = Not Used
 * Denotes install load resistor. See load resistor installation detail this sheet.
 ★ See pictorial of head wiring in detail this sheet.

FYA SIGNAL WIRING DETAIL

(wire signal heads as shown)

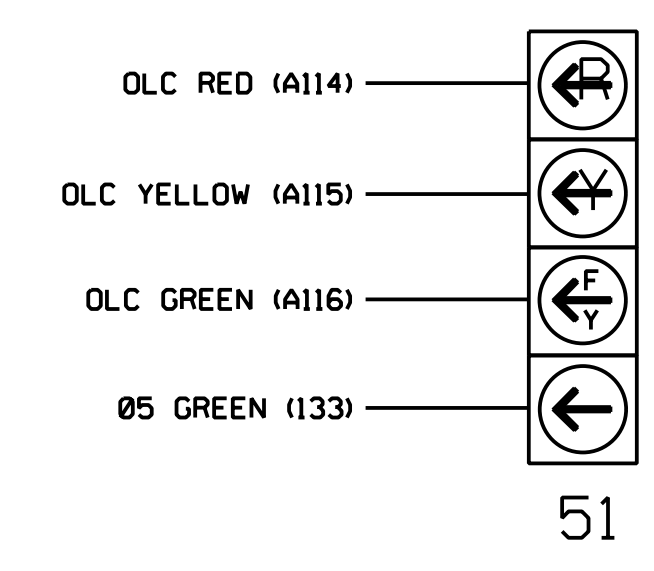

NOTE
 The sequence display for signal heads 51 requires special logic programming. See sheet 2 for programming instructions.

INPUT FILE POSITION LAYOUT

(front view)

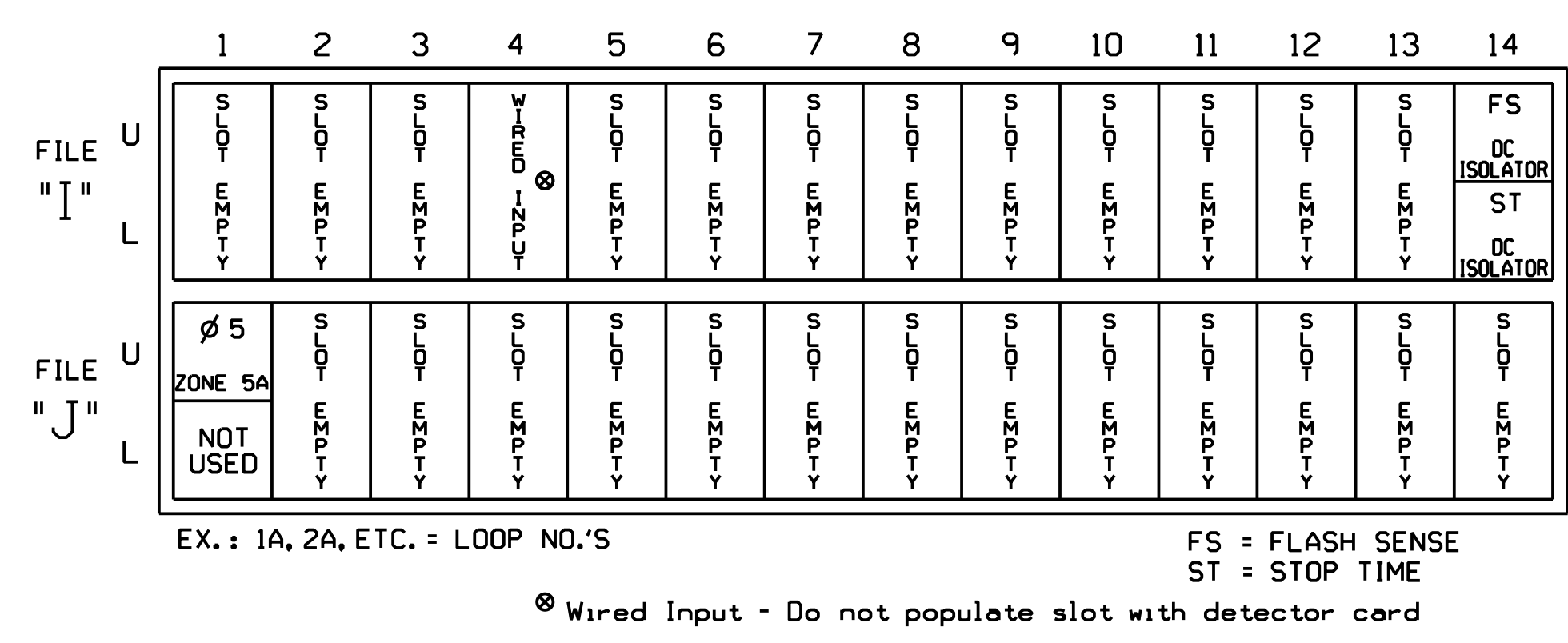

INPUT FILE CONNECTION & PROGRAMMING CHART

LOOP NO.	LOOP TERMINAL	INPUT FILE POS.	PIN NO.	INPUT ASSIGNMENT NO.	DETECTOR NO.	NEMA PHASE	CALL	EXTEND	FULL TIME DELAY	STRETCH TIME	DELAY TIME
ZONE 5A ¹	★	J1U	55	17	5	5	Y	Y			15
	-	I4U	47	9★	22	2	Y	Y	Y		3
	-	J1U	55	17★	55	5	Y	Y			3

- ¹Add jumper from J1-W to I4-W, on rear of input file.
 ★ See vehicle detector setup programming detail for alternate phasing on sheet 3.
 ★★ Multizone Microwave Detector Zone. See Special Detector Note.

INPUT FILE POSITION LEGEND: J2L

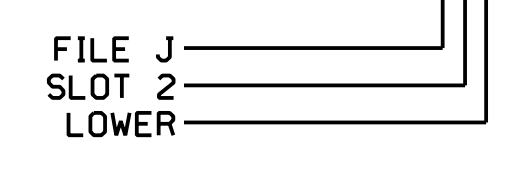

SPECIAL DETECTOR NOTE

Install a microwave detection system for vehicle detection. Perform installation according to manufacturer's directions and NCDOT engineer-approved mounting locations to accomplish the detection schemes shown on the Signal Design Plans.
 For loop 5A detector card placement and slots reserved for wired inputs are typical for a NCDOT installation. Inputs associated with these slots are compatible with the time of day instructions located on sheet 3 and 4 of this electrical detail.

LOAD RESISTOR INSTALLATION DETAIL

(install resistor as shown)

VALUE (ohms)	WATTAGE
1.5K - 1.9K	25W (min)
2.0K - 3.0K	10W (min)

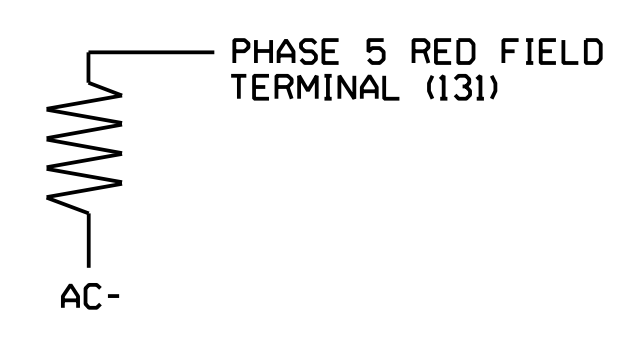

Electrical Detail - Sheet 1 of 4
 New Installation
 Temporary Design 1

DOCUMENT NOT CONSIDERED FINAL UNLESS ALL SIGNATURES COMPLETED

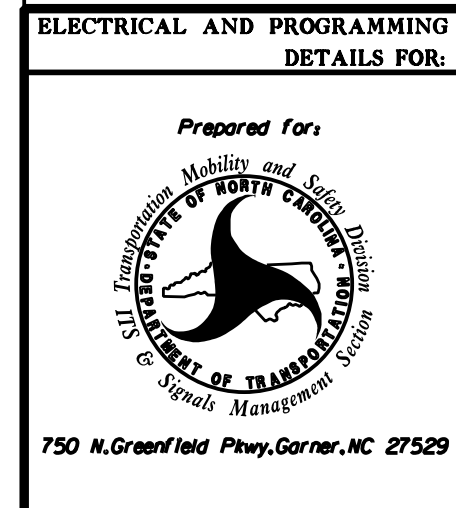

NC 906 (Midway Road) at NC 211 Northbound Ramp/ Midway Commons Driveway	
Division 03 Brunswick Co. Southport	
PLAN DATE: June 2017	REVIEWED BY: A.D. Klinksiek
PREPARED BY: A.H. Thornburg	REVIEWED BY: N.R. Simmons
REVISIONS	INIT. DATE

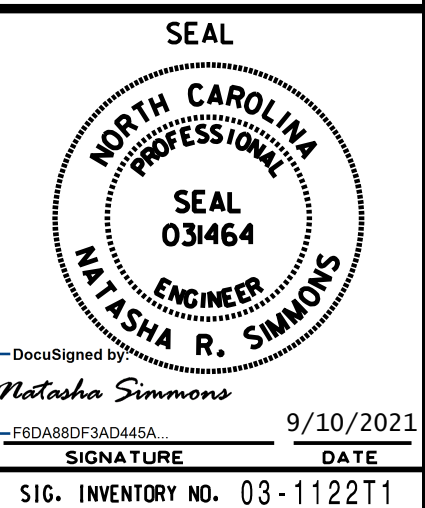

HNTB HNTB NORTH CAROLINA, P.C.
 343 E. Six Forks Road, Suite 200
 Raleigh, North Carolina 27609
 NC license No: C-1554
 (919) 546-8997

DocuSigned by:
 Natasha Simmons
 9/10/2021
 SIGNATURE DATE
 SIG. INVENTORY NO. 03-1122T1

**LOGICAL I/O PROCESSOR PROGRAMMING DETAIL
TO PRODUCE SPECIAL FYA-PPLT SIGNAL SEQUENCE**

(program controller as shown below)

1. FROM MAIN MENU PRESS '2' (PHASE CONTROL), THEN '1' (PHASE CONTROL FUNCTIONS). SCROLL TO THE BOTTOM OF THE MENU AND ENABLE ACT LOGIC COMMANDS 1, 2, AND 3.
2. FROM MAIN MENU PRESS '6' (OUTPUTS), THEN '3' (LOGICAL I/O PROCESSOR).

```

LOGICAL I/O COMMAND #1 (+/-COMMAND#)
IF ACTIVE PHASE #5 IS ON
AND RED CLEAR ON PHASE #5 IS ON

          ↓
          SCROLL DOWN

THEN:
SET OUTPUT ASSIGNMENT #42 ON
SET OUTPUT ASSIGNMENT #43 OFF
    
```

NOTE: LOGIC FOR PHASE 5 RED CLEAR WHEN TRANSITIONING FROM PHASE 5 TO PHASE 6 (HEAD 51).

```

LOGICAL I/O COMMAND #2 (+/-COMMAND#)
IF ACTIVE PHASE #5 IS ON

          ↓
          SCROLL DOWN

THEN:
SET OUTPUT ASSIGNMENT #44 OFF
    
```

NOTE: LOGIC FOR SWITCHING FLASHING YELLOW ARROW "OFF" DURING PHASE 5 (HEAD 51).

```

LOGICAL I/O COMMAND #3 (+/-COMMAND#)
IF YELLOW ON PHASE #5 IS ON

          ↓
          SCROLL DOWN

THEN:
SET OUTPUT ASSIGNMENT #43 ON
    
```

NOTE: LOGIC FOR YELLOW ARROW CLEARANCE FROM PHASE 5 (HEAD 51).

LOGIC I/O PROCESSOR PROGRAMMING COMPLETE

OUTPUT REFERENCE SCHEDULE
USE TO INTERPRET LOGIC PROCESSOR

OUTPUT 42 = Overlap C Red
OUTPUT 43 = Overlap C Yellow
OUTPUT 44 = Overlap C Green

**OVERLAP PROGRAMMING DETAIL
FOR DEFAULT PHASING**

(program controller as shown below)

FROM MAIN MENU PRESS '8' (OVERLAPS), THEN '1' (VEHICLE OVERLAP SETTINGS).

PRESS '+' TWICE

```

PAGE 1: VEHICLE OVERLAP 'C' SETTINGS
PHASE:           ;12345678910111213141516
VEH OVL PARENTS: ; XX
VEH OVL NOT VEH: ;
VEH OVL NOT PED: ;
VEH OVL GRN EXT: ;
STARTUP COLOR:  - RED - YELLOW - GREEN
FLASH COLORS:   - RED - YELLOW X GREEN
SELECT VEHICLE OVERLAP OPTIONS: (Y/N)
FLASH YELLOW IN CONTROLLER FLASH?...Y
GREEN EXTENSION (0-255 SEC).....0.0
YELLOW CLEAR (0=PARENT.3-25.5 SEC)...0.0
RED CLEAR (0=PARENT.0.1-25.5 SEC)...0.0
OUTPUT AS PHASE # (0=NONE, 1-16)....0
    
```

NOTICE GREEN FLASH

OVERLAP PROGRAMMING COMPLETE

**OVERLAP PROGRAMMING DETAIL
FOR ALTERNATE PHASING**

(program controller as shown below)

FROM MAIN MENU PRESS '8' (OVERLAPS), THEN '1' (VEHICLE OVERLAP SETTINGS). PRESS 'NEXT' TO ADVANCE TO PAGE 2.

PRESS '+' TWICE

NOTICE PAGE 2

```

PAGE 2: VEHICLE OVERLAP 'C' SETTINGS
PHASE:           ;12345678910111213141516
VEH OVL PARENTS: ; X
VEH OVL NOT VEH: ;
VEH OVL NOT PED: ;
VEH OVL GRN EXT: ;
STARTUP COLOR:  - RED - YELLOW - GREEN
FLASH COLORS:   - RED - YELLOW - GREEN
SELECT VEHICLE OVERLAP OPTIONS: (Y/N)
FLASH YELLOW IN CONTROLLER FLASH?...Y
GREEN EXTENSION (0-255 SEC).....0.0
YELLOW CLEAR (0=PARENT.3-25.5 SEC)...0.0
RED CLEAR (0=PARENT.0.1-25.5 SEC)...0.0
OUTPUT AS PHASE # (0=NONE, 1-16)....0
    
```

OVERLAP PROGRAMMING COMPLETE

THIS ELECTRICAL DETAIL IS FOR THE SIGNAL DESIGN: 03-1122T1
DESIGNED: June 2017
SEALED: 9/10/2021
REVISED: N/A

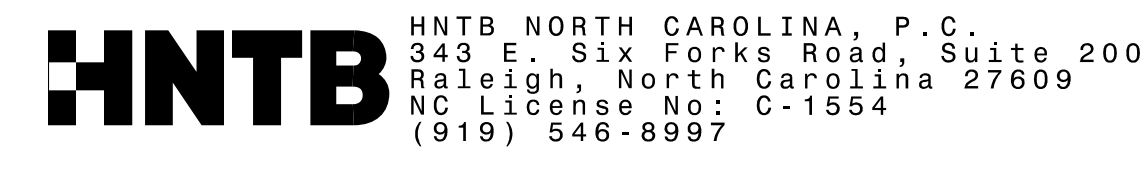

Electrical Detail - Sheet 2 of 4
New Installation
Temporary Design 1

**DOCUMENT NOT CONSIDERED FINAL
UNLESS ALL SIGNATURES COMPLETED**

	Prepared for: NC 906 (Midway Road) at NC 211 Northbound Ramp/ Midway Commons Driveway		
	Division 03 Brunswick Co. Southport	PLAN DATE: June 2017 REVIEWED BY: A.D. Klinksiek PREPARED BY: A.H. Thornburg REVIEWED BY: N.R. Simmons	
REVISIONS		INIT. DATE	Signature: <i>Natasha Simmons</i> 9/10/2021 DATE
SIG. INVENTORY NO. 03-1122T1			DATE

INPUT PAGE 2 ASSIGNMENT PROGRAMMING DETAIL FOR ALTERNATE PHASING - LOOP 5A

(program controller as shown below)

- NOTES: 1. THIS PROGRAMMING APPLIES FOR INPUT PAGE 2 ONLY. INPUT PAGE 1 WILL USE STANDARD DEFAULT SETTINGS. THIS PROGRAMMING IS NECESSARY FOR PROPER DETECTOR OPERATION DURING ALTERNATE PHASING OPERATION. 2. THE FIRST TASK THIS PROGRAMMING ACCOMPLISHES IS THE DISABLING OF INPUT #9 (DETECTOR 22) SO THAT A VEHICLE CALL WILL NOT BE PLACED TO PHASE 2 DURING ALTERNATE PHASING OPERATION. THE SECOND TASK THIS PROGRAMMING ACCOMPLISHES IS THAT IT REASSIGNS DETECTOR 55 TO INPUT #17 SO THAT THE DELAY ON LOOP 5A CAN BE REDUCED FROM 15 SECONDS TO 3 SECONDS.

FROM MAIN MENU PRESS '5' (INPUTS), THEN PRESS 'NEXT' TO GET TO INPUT PAGE '2'. PRESS THE '+' KEY UNTIL INPUT 9 IS REACHED.

PAGE: 2 C1 PIN:47 VEHICLE DETECTOR INPUT ASSIGNMENT #.....9 DEBOUNCE TIME (0-25.5 SEC).....0.5 DELAY TIME (0-25.5 SEC).....0.0 HOLD-OVER TIME (0-25.5 SEC).....0.0 ASSIGNMENT SELECTION: NOT ENABLED (Y/N).....Y VEHICLE DETECTOR (1-64).....22 PEDESTRIAN DETECTOR (1-16)..... ALTERNATE PED DETECTOR (1-16)..... PREEMPT (1-10)..... INVERTED PREEMPT (1-10)..... STOP TIME (Y/N)..... FLASH SENSE (Y/N)..... DOOR OPEN (Y/N)..... MANUAL CONTROL ENABLE (Y/N)..... MANUAL CONTROL ADVANCE (Y/N)..... SPECIAL FUNCTION ALARM (1-8)..... TOD HOUR SYNCHRONIZATION (0-23)..... FORCE OFF RING (1-4)..... HOLD PHASES (1-16)..... PLAN (65=FLSH,66=FREE)..... OFFSET#..... CHANGE PHASE SEQUENCE PAGE (1-12)..... CHANGE PHASE SEQUENCE PAGE (1-12)..... CHANGE PHASE TIMING PAGE (1-4)..... CHANGE PHASE CONTROL PAGE (1-4)..... CHANGE OVERLAP CONTROL PAGE (1-4)..... CHANGE INPUT PAGE (1-4)..... CHANGE OUTPUT PAGE (1-4)..... OVERRIDE PHASE CONTROL FUNCTION (Y).....

ENTER A 'Y' FOR NOT ENABLED

DEFAULT DETECTOR NUMBER WILL REMAIN UNTIL 'NOT ENABLED' IS ENTERED.

(LOOP 5A - PHASE 2)

PAGE: 2 C1 PIN:47 NOT ENABLED INPUT ASSIGNMENT #.....9 DEBOUNCE TIME (0-25.5 SEC).....0.5 DELAY TIME (0-25.5 SEC).....0.0 HOLD-OVER TIME (0-25.5 SEC).....0.0 ASSIGNMENT SELECTION: NOT ENABLED (Y/N).....Y VEHICLE DETECTOR (1-64)..... PEDESTRIAN DETECTOR (1-16)..... ALTERNATE PED DETECTOR (1-16)..... PREEMPT (1-10)..... INVERTED PREEMPT (1-10)..... STOP TIME (Y/N)..... FLASH SENSE (Y/N)..... DOOR OPEN (Y/N)..... MANUAL CONTROL ENABLE (Y/N)..... MANUAL CONTROL ADVANCE (Y/N)..... SPECIAL FUNCTION ALARM (1-8)..... TOD HOUR SYNCHRONIZATION (0-23)..... FORCE OFF RING (1-4)..... HOLD PHASES (1-16)..... PLAN (65=FLSH,66=FREE)..... OFFSET#..... CHANGE PHASE SEQUENCE PAGE (1-12)..... CHANGE PHASE SEQUENCE PAGE (1-12)..... CHANGE PHASE TIMING PAGE (1-4)..... CHANGE PHASE CONTROL PAGE (1-4)..... CHANGE OVERLAP CONTROL PAGE (1-4)..... CHANGE INPUT PAGE (1-4)..... CHANGE OUTPUT PAGE (1-4)..... OVERRIDE PHASE CONTROL FUNCTION (Y).....

PRESS '+' TO ADVANCE TO INPUT 17

PAGE: 2 C1 PIN:55 VEHICLE DETECTOR INPUT ASSIGNMENT #.....17 DEBOUNCE TIME (0-25.5 SEC).....0.5 DELAY TIME (0-25.5 SEC).....0.0 HOLD-OVER TIME (0-25.5 SEC).....0.0 ASSIGNMENT SELECTION: NOT ENABLED (Y/N)..... VEHICLE DETECTOR (1-64).....5 PEDESTRIAN DETECTOR (1-16)..... ALTERNATE PED DETECTOR (1-16)..... PREEMPT (1-10)..... INVERTED PREEMPT (1-10)..... STOP TIME (Y/N)..... FLASH SENSE (Y/N)..... DOOR OPEN (Y/N)..... MANUAL CONTROL ENABLE (Y/N)..... MANUAL CONTROL ADVANCE (Y/N)..... SPECIAL FUNCTION ALARM (1-8)..... TOD HOUR SYNCHRONIZATION (0-23)..... FORCE OFF RING (1-4)..... HOLD PHASES (1-16)..... PLAN (65=FLSH,66=FREE)..... OFFSET#..... CHANGE PHASE SEQUENCE PAGE (1-12)..... CHANGE PHASE SEQUENCE PAGE (1-12)..... CHANGE PHASE TIMING PAGE (1-4)..... CHANGE PHASE CONTROL PAGE (1-4)..... CHANGE OVERLAP CONTROL PAGE (1-4)..... CHANGE INPUT PAGE (1-4)..... CHANGE OUTPUT PAGE (1-4)..... OVERRIDE PHASE CONTROL FUNCTION (Y).....

ENTER '55' TO REASSIGN THE VEHICLE DETECTOR FOR THIS INPUT

(LOOP 5A - PHASE 5)

PAGE: 2 C1 PIN:55 VEHICLE DETECTOR INPUT ASSIGNMENT #.....17 DEBOUNCE TIME (0-25.5 SEC).....0.5 DELAY TIME (0-25.5 SEC).....0.0 HOLD-OVER TIME (0-25.5 SEC).....0.0 ASSIGNMENT SELECTION: NOT ENABLED (Y/N)..... VEHICLE DETECTOR (1-64).....55 PEDESTRIAN DETECTOR (1-16)..... ALTERNATE PED DETECTOR (1-16)..... PREEMPT (1-10)..... INVERTED PREEMPT (1-10)..... STOP TIME (Y/N)..... FLASH SENSE (Y/N)..... DOOR OPEN (Y/N)..... MANUAL CONTROL ENABLE (Y/N)..... MANUAL CONTROL ADVANCE (Y/N)..... SPECIAL FUNCTION ALARM (1-8)..... TOD HOUR SYNCHRONIZATION (0-23)..... FORCE OFF RING (1-4)..... HOLD PHASES (1-16)..... PLAN (65=FLSH,66=FREE)..... OFFSET#..... CHANGE PHASE SEQUENCE PAGE (1-12)..... CHANGE PHASE SEQUENCE PAGE (1-12)..... CHANGE PHASE TIMING PAGE (1-4)..... CHANGE PHASE CONTROL PAGE (1-4)..... CHANGE OVERLAP CONTROL PAGE (1-4)..... CHANGE INPUT PAGE (1-4)..... CHANGE OUTPUT PAGE (1-4)..... OVERRIDE PHASE CONTROL FUNCTION (Y).....

PROGRAMMING COMPLETE

SPECIAL DETECTOR PROGRAMMING DETAIL - LOOP 5A (ALT.)

(program controller as shown below)

FROM MAIN MENU PRESS '7' (DETECTORS), THEN PRESS '1' FOR VEHICLE DETECTORS. PRESS THE '-' KEY TO GET TO VEHICLE DETECTOR #55.

VEHICLE DETECTOR #55 SETTINGS (+,-,1-64) SETTING: (Y/N) ENABLE DETECTOR.....N ENABLE LOGGING.....N ENABLE DIAGNOSTICS.....N SPEED TRAP.....N CALL DETECTOR.....Y EXTENSION DETECTOR.....Y MODE 2 STOP BAR.....N SWITCHING DETECTOR.....N DUPLICATING DETECTOR.....N ENABLE FULL TIME DELAY.....N IF FAILED, SET MIN RECALL?.....N IF FAILED, SET MAX1 RECALL?.....N IF FAILED, SET MAX2 RECALL?.....N PHASE# :12345678910111213141516 PHASES ASSIGNED : SWITCH/DUPLICATE: LOOP SIZE (0-255 FT).....6 SPEED TRAP DISTANCE (0-255 FT).....0 STOP BAR TIME (0-255 SEC).....0 STRETCH (0-25.5 SEC).....0.0 DELAY (0-255 SEC).....0 MAX CALLS/MIN (0-255).....255 MIN CALLS/DIAGNOSTIC PERIOD (0-255).....0 MAX OCCUPANCY (0-100%).....100 EXTENSION DISABLE TIME (0-255 SEC).....0 QUEUE MAX OCCUPANCY TIME (0-255).....0 QUEUE GAP RESET TIME (0-25.5).....0.0 PREEMPTION INDEX FOR QUEUE (0-10).....0

ENTER 'Y' FOR ENABLE DETECTOR

ENTER '5' FOR PHASES ASSIGNED

ENSURE DELAY IS '3'

VEHICLE DETECTOR #55 SETTINGS (+,-,1-64) SETTING: (Y/N) ENABLE DETECTOR.....Y ENABLE LOGGING.....N ENABLE DIAGNOSTICS.....N SPEED TRAP.....N CALL DETECTOR.....Y EXTENSION DETECTOR.....Y MODE 2 STOP BAR.....N SWITCHING DETECTOR.....N DUPLICATING DETECTOR.....N ENABLE FULL TIME DELAY.....N IF FAILED, SET MIN RECALL?.....N IF FAILED, SET MAX1 RECALL?.....N IF FAILED, SET MAX2 RECALL?.....N PHASE# :12345678910111213141516 PHASES ASSIGNED : X SWITCH/DUPLICATE: LOOP SIZE (0-255 FT).....6 SPEED TRAP DISTANCE (0-255 FT).....0 STOP BAR TIME (0-255 SEC).....0 STRETCH (0-25.5 SEC).....0.0 DELAY (0-255 SEC).....3 MAX CALLS/MIN (0-255).....255 MIN CALLS/DIAGNOSTIC PERIOD (0-255).....0 MAX OCCUPANCY (0-100%).....100 EXTENSION DISABLE TIME (0-255 SEC).....0 QUEUE MAX OCCUPANCY TIME (0-255).....0 QUEUE GAP RESET TIME (0-25.5).....0.0 PREEMPTION INDEX FOR QUEUE (0-10).....0

DETECTOR PROGRAMMING COMPLETE

NOTE: DETECTOR IS PROGRAMMED PER THE INPUT FILE CONNECTION AND PROGRAMMING CHART SHOWN ON SHEET 1.

THIS ELECTRICAL DETAIL IS FOR THE SIGNAL DESIGN: 03-1122T1 DESIGNED: June 2017 SEALED: 9/10/2021 REVISED: N/A

Electrical Detail - Sheet 3 of 4 New Installation Temporary Design 1

DOCUMENT NOT CONSIDERED FINAL UNLESS ALL SIGNATURES COMPLETED

Table with project details: NC 906 (Midway Road) at NC 211 Northbound Ramp/Midway Commons Driveway. Includes fields for Division 03, Brunswick Co., Southport, PLAN DATE: June 2017, REVIEWED BY: A.D. Klinksiek, PREPARED BY: A.H. Thornburg, REVIEWED BY: N.R. Simmons, and a signature block for N. R. Simmons dated 9/10/2021.

ALTERNATE PHASING ACTIVATION DETAIL

TO RUN ALT. PHASING DURING COORDINATION - SELECT ALL PAGE CHANGES (AS SHOWN BELOW) WITHIN COORDINATION PLAN PROGRAMMING.

TO RUN ALT. PHASING DURING FREE RUN - PROGRAM PAGE CHANGES (SHOWN BELOW) IN SEPARATE TIME OF DAY EVENTS. IF PAGE 1 IS USED, NO EVENT PROGRAMMING IS NECESSARY FOR THAT PARTICULAR PAGE.

<u>PHASING</u>	<u>INPUTS PAGE</u>	<u>OVERLAPS PAGE</u>
ACTIVE PAGES REQUIRED TO RUN <u>DEFAULT PHASING</u>	1	1
ACTIVE PAGES REQUIRED TO RUN <u>ALTERNATE PHASING</u>	2	2

NOTE: PAGES NOT SHOWN (i.e. sequence, phase control, etc.) SHOULD REMAIN AS '1', OR AS DEFINED BY TIMING ENGINEER.

IMPORTANT: IF ALT. PHASING IS USED DURING FREE RUN AND COORDINATION, DO NOT OPERATE TIME OF DAY PAGE CHANGE EVENTS CONCURRENTLY WITH COORDINATION PLAN EVENTS IN THE EVENT SCHEDULER. (EX. FREE RUN PAGE CHANGE EVENT SHOULD END BEFORE COORDINATION PLAN EVENT STARTS AND VICE-VERSA).

ALTERNATE PHASING PAGE CHANGE SUMMARY

THE FOLLOWING IS A SUMMARY OF WHAT TAKES PLACE WHEN THESE OVERLAP/INPUT PAGE CHANGES ACTIVATE TO CALL THE "ALTERNATE PHASING":

OVERLAPS PAGE 2: Modifies overlap parent phases for head 51 to run protected turns only.

INPUTS PAGE 2: Disables phase 2 call on loop 5A and reduces delay time for phase 5 call on loop 5A to 3 seconds.

THIS ELECTRICAL DETAIL IS FOR THE SIGNAL DESIGN: 03-1122T1
 DESIGNED: June 2017
 SEALED: 9/10/2021
 REVISED: N/A

Electrical Detail - Sheet 4 of 4
 New Installation
 Temporary Design 1

**DOCUMENT NOT CONSIDERED FINAL
 UNLESS ALL SIGNATURES COMPLETED**

HNTB HNTB NORTH CAROLINA, P.C.
 343 E. Six Forks Road, Suite 200
 Raleigh, North Carolina 27609
 NC License No: C-1554
 (919) 546-8997

<p style="text-align: center;"><small>Prepared for:</small></p> <p style="text-align: center;"><small>750 N. Greenfield Pkwy, Corner, NC 27529</small></p>	<p style="text-align: center;">NC 906 (Midway Road) at NC 211 Northbound Ramp/ Midway Commons Driveway</p> <p style="text-align: center;">Division 03 Brunswick Co. Southport</p> <table border="1" style="width: 100%; border-collapse: collapse;"> <tr> <td style="width: 50%;"><small>PLAN DATE:</small> June 2017</td> <td style="width: 50%;"><small>REVIEWED BY:</small> A.D. Klinksiek</td> </tr> <tr> <td><small>PREPARED BY:</small> A.H. Thornburg</td> <td><small>REVIEWED BY:</small> N.R. Simmons</td> </tr> </table> <table border="1" style="width: 100%; border-collapse: collapse;"> <thead> <tr> <th style="width: 60%;"><small>REVISIONS</small></th> <th style="width: 20%;"><small>INIT.</small></th> <th style="width: 20%;"><small>DATE</small></th> </tr> </thead> <tbody> <tr> <td> </td> <td> </td> <td> </td> </tr> </tbody> </table>	<small>PLAN DATE:</small> June 2017	<small>REVIEWED BY:</small> A.D. Klinksiek	<small>PREPARED BY:</small> A.H. Thornburg	<small>REVIEWED BY:</small> N.R. Simmons	<small>REVISIONS</small>	<small>INIT.</small>	<small>DATE</small>				<p>SEAL</p> <p style="text-align: center;"><small>DocuSigned by: Natasha Simmons 9/10/2021</small></p> <p style="text-align: center;"><small>SIGNATURE DATE</small></p> <p style="text-align: center;"><small>SIG. INVENTORY NO. 03-1122T1</small></p>
<small>PLAN DATE:</small> June 2017	<small>REVIEWED BY:</small> A.D. Klinksiek											
<small>PREPARED BY:</small> A.H. Thornburg	<small>REVIEWED BY:</small> N.R. Simmons											
<small>REVISIONS</small>	<small>INIT.</small>	<small>DATE</small>										

DEFAULT PHASING DIAGRAM

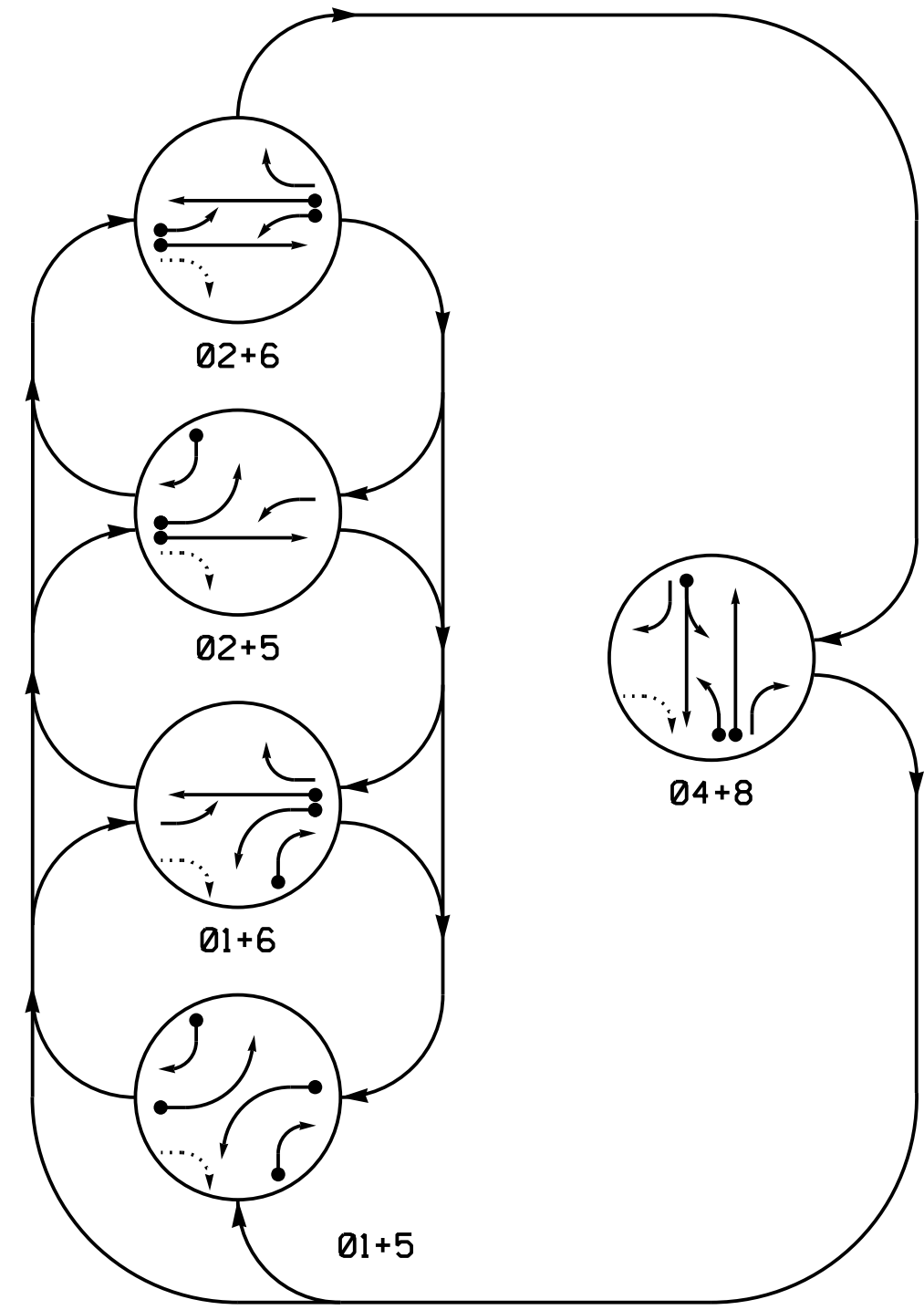

ALTERNATE PHASING DIAGRAM

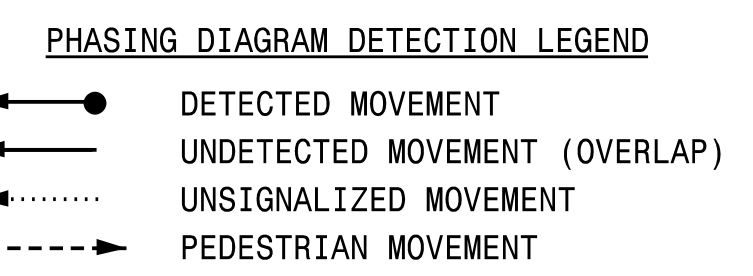
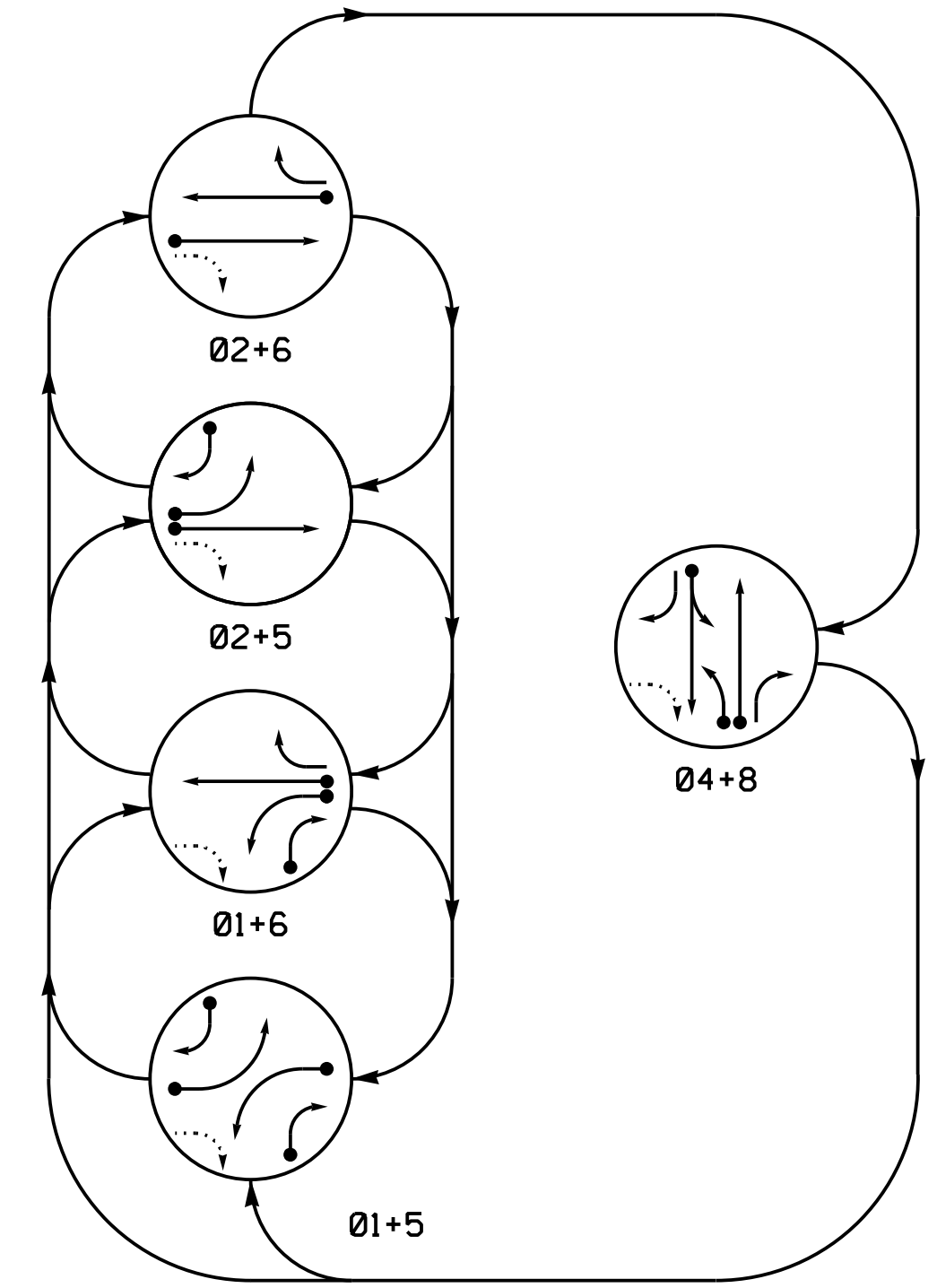

DEFAULT PHASING TABLE OF OPERATION

SIGNAL FACE	PHASE					
	01+5	01+6	02+5	02+6	04+8	F Ped
11	---	---	F	F	R	Y
21,22	R	R	G	G	R	Y
41	R	R	R	R	G	R
42	R	R	R	R	G	R
51	---	---	F	F	R	Y
61,62	R	G	R	G	R	Y
81	R	R	R	R	G	R
82	R	R	R	R	G	R

ALTERNATE PHASING TABLE OF OPERATION

SIGNAL FACE	PHASE					
	01+5	01+6	02+5	02+6	04+8	F Ped
11	---	---	R	R	R	Y
21,22	R	R	G	G	R	Y
41	R	R	R	R	G	R
42	R	R	R	R	G	R
51	---	---	R	R	R	Y
61,62	R	G	R	G	R	Y
81	R	R	R	R	G	R
82	R	R	R	R	G	R

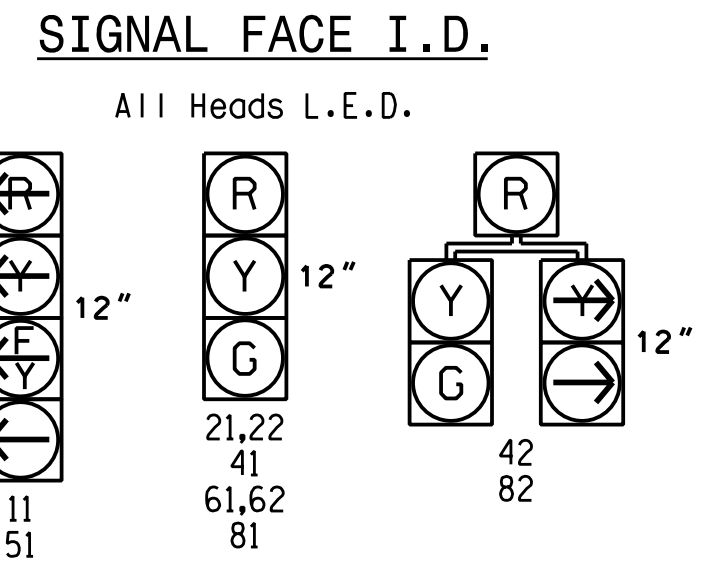

OASIS 2070 LOOP & DETECTOR INSTALLATION CHART

LOOP	SIZE (FT)	DISTANCE FROM STOPBAR (FT)	TURNS	NEW LOOP	PHASE			STRETCH TIME	DELAY TIME	SYSTEM LOOP	NEW CARD
					PHASE	CALLING	EXTENSION				
1A	6X40	0	*	*	1	Y	Y	-	-	***15	-
1B	6X40	0	*	*	1	Y	Y	-	-	3	-
2A	6X6	300	*	*	2	Y	Y	-	-	-	-
4A	6X40	0	*	*	4	Y	Y	-	-	-	-
5A	6X40	0	*	*	5	Y	Y	-	-	***15	-
5B	6X40	0	*	*	5	Y	Y	-	-	15	-
6A	6X6	300	*	*	6	Y	Y	-	-	-	-
8A	6X40	0	*	*	8	Y	Y	-	-	-	-
8B	6X40	0	*	*	8	Y	Y	-	-	-	-

* Multizone Microwave Detection.
 ** Disable phase 2 and 6 call for 1A and 5A during alternate phasing operation.
 *** Reduce delay to 3 seconds during alternate phasing operation.

5 Phase Fully Actuated Isolated

NOTES

- Refer to "Roadway Standard Drawings NCDOT" dated January 2018 and "Standard Specifications for Roads and Structures" dated January 2018.
- Do not program signal for late night flashing operation unless otherwise directed by the Engineer.
- Phase 1 and/or phase 5 may be lagged.
- Reposition existing signal heads numbered 21,22, and 51.
- Set all detector units to presence mode.
- The Division Traffic Engineer will determine the hours of use for each phasing plan.
- Incorporate Microwave Detection system for vehicle detection.
- Provide the Engineer with the Manufacturer's approved Microwave Detection locations and mounting heights to obtain detection zones as shown.

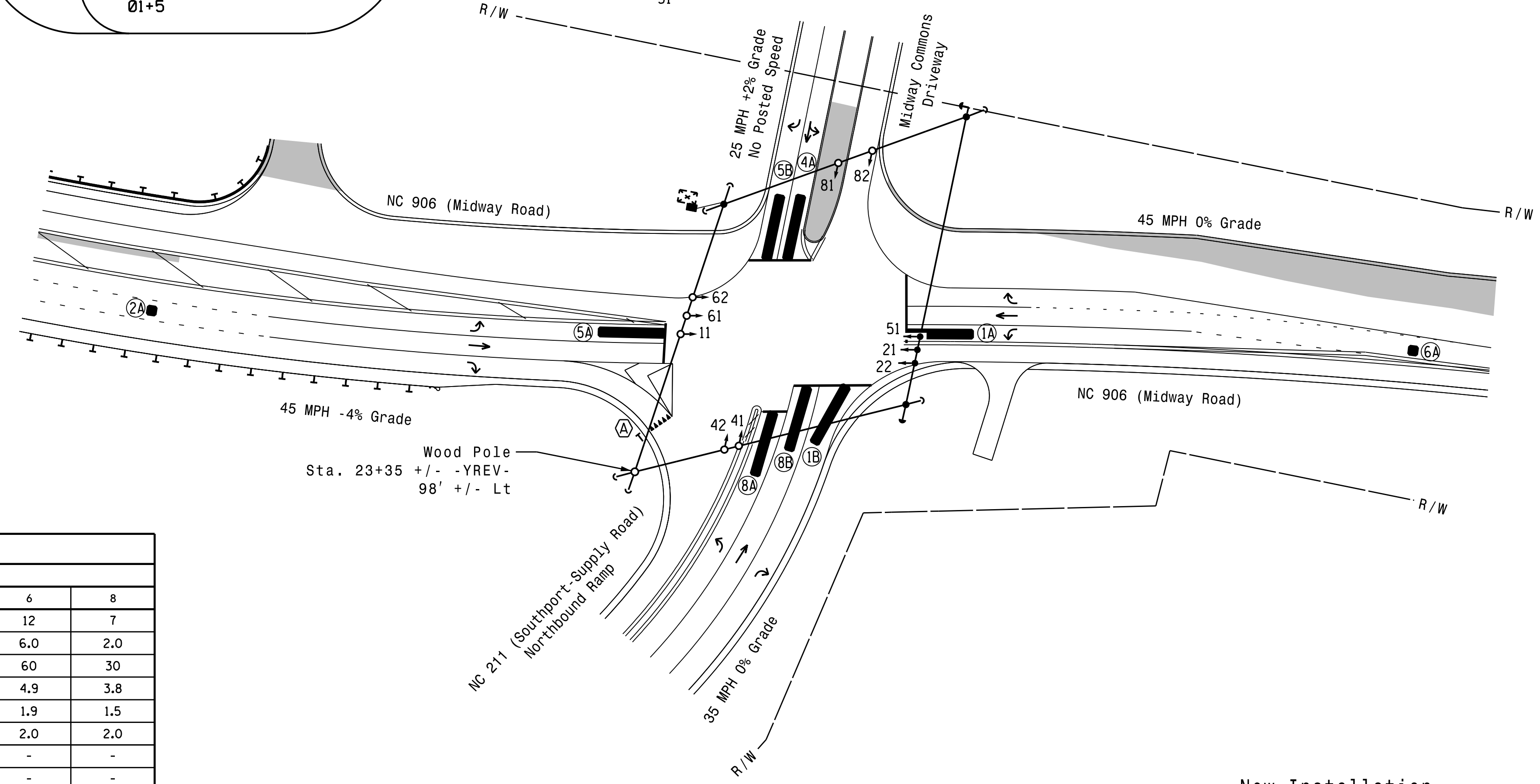

OASIS 2070 TIMING CHART

FEATURE	PHASE					
	1	2	4	5	6	8
Min Green 1 *	7	12	7	7	12	7
Extension 1 *	2.0	6.0	2.0	2.0	6.0	2.0
Max Green 1 *	20	60	30	20	60	30
Yellow Clearance	3.0	4.9	3.1	3.0	4.9	3.8
Red Clearance	3.1	1.9	2.5	3.3	1.9	1.5
Red Revert	2.0	2.0	2.0	2.0	2.0	2.0
Walk 1 *	-	-	-	-	-	-
Don't Walk 1	-	-	-	-	-	-
Seconds Per Actuation *	-	2.5	-	-	2.5	-
Max Variable Initial *	-	34	-	-	34	-
Time Before Reduction *	-	15	-	-	15	-
Time To Reduce *	-	30	-	-	30	-
Minimum Gap	-	3.0	-	-	3.0	-
Recall Mode	-	MIN RECALL	-	-	MIN RECALL	-
Vehicle Call Memory	-	YELLOW	-	-	YELLOW	-
Dual Entry	-	-	ON	-	-	ON
Simultaneous Gap	ON	ON	ON	ON	ON	ON

* These values may be field adjusted. Do not adjust Min Green and Extension times for phases 2 and 6 lower than what is shown. Min Green for all other phases should not be lower than 4 seconds.

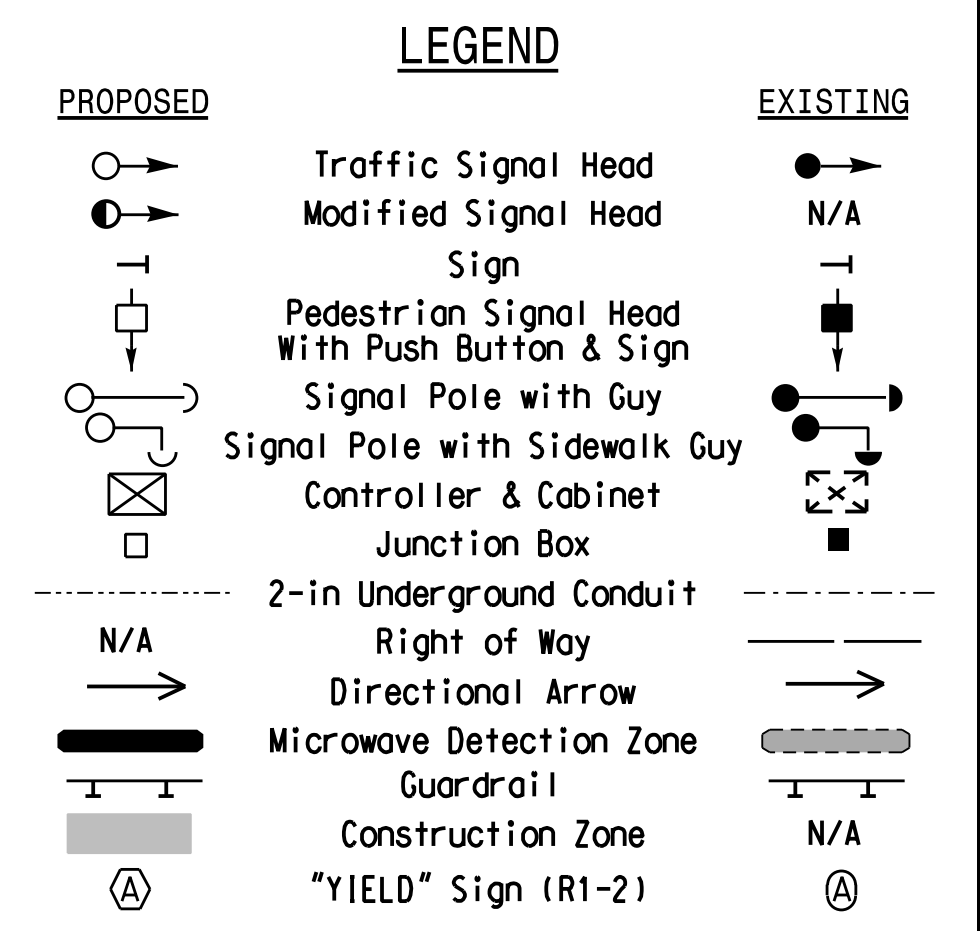

New Installation
 Temporary Design 2
 Construction Phase 3

DOCUMENT NOT CONSIDERED FINAL UNLESS ALL SIGNATURES COMPLETED

<p>HNTB NORTH CAROLINA, P.C. 343 E. Six Forks Road, Suite 200 Raleigh, North Carolina 27609 NC License No: C-1554 (919) 546-8997</p>	Prepared For: TRANSPORTATION MOBILITY AND SAFETY DIVISION STATE OF NORTH CAROLINA SIGNAL DESIGN SECTION	NC 906 (Midway Road) at NC 211 Northbound Ramp/ Midway Commons Driveway Division 03 Brunswick Co. Southport PLAN DATE: June 2017 REVIEWED BY: A.D. Klinksiek PREPARED BY: A.H. Thornburg REVIEWED BY: N.R. Simmons	SEAL SEAL 031464 NATASHA R. SIMMONS ENGINEER 9/10/2021 SIGNATURE DATE SIG. INVENTORY NO. 03-1122T2
	SCALE 0 50 1"=50'	REVISIONS INIT. DATE	REVISIONS INIT. DATE

EDI MODEL 2018ECL-NC CONFLICT MONITOR PROGRAMMING DETAIL

(remove jumpers and set switches as shown)

REMOVE DIODE JUMPERS 1-5, 1-6, 1-9, 1-11, 2-5, 2-6, 2-9, 2-11, 4-8, 5-9, 5-11, 6-9, 6-11, and 9-11.

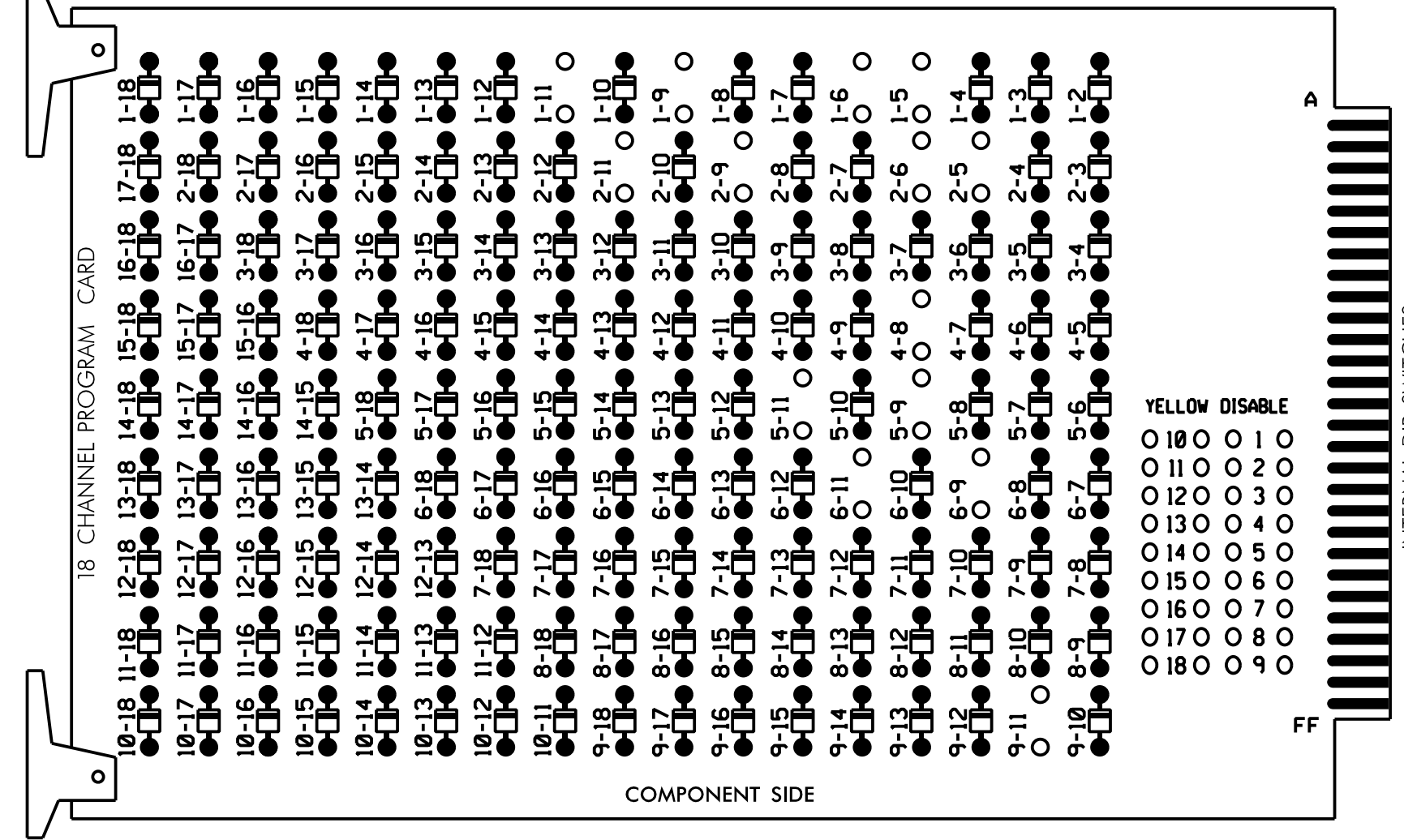

REMOVE JUMPERS AS SHOWN

NOTES:

- Card is provided with all diode jumpers in place. Removal of any jumper allows its channels to run concurrently.
- Ensure jumpers SEL2-SEL5 and SEL9 are present on the monitor board.
- Ensure that Red Enable is active at all times during normal operation.
- Connect serial cable from conflict monitor to comm. port 1 of 2070 controller. Ensure conflict monitor communicates with 2070.

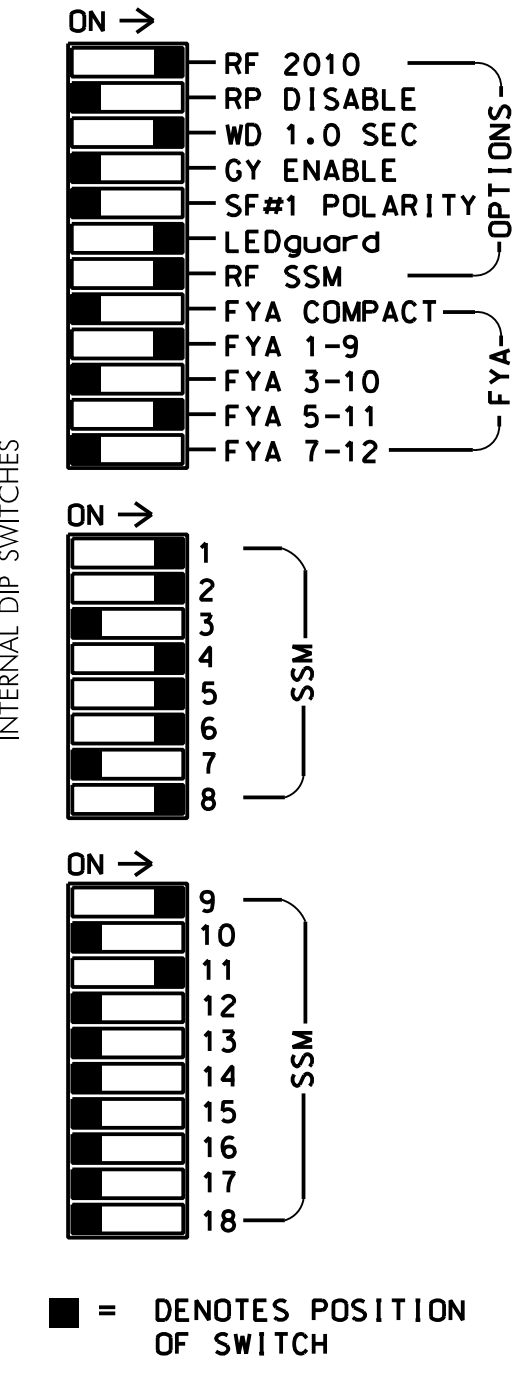
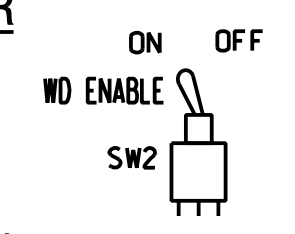

NOTES

- To prevent "flash-conflict" problems, insert red flash program blocks for all unused vehicle load switches in the output file. The installer shall verify that signal heads flash in accordance with the Signal Plans.
- Program phases 4 and 8 for Dual Entry.
- Enable Simultaneous Gap-Out for all Phases.
- Program phases 2 and 6 for Variable Initial and Gap Reduction.
- Program phases 2 and 6 for Startup In Green.
- Program phases 2 and 6 for Yellow Flash, and overlap 1 as Wag Overlaps.
- If this signal will be managed by an ATMS software, enable controller and detector logging for all detectors used at this location.

EQUIPMENT INFORMATION

CONTROLLER.....2070E
 CABINET.....332 W/AUX
 SOFTWARE.....ECONOLITE OASIS
 CABINET MOUNT.....BASE
 OUTPUT FILE POSITIONS...18 WITH AUX. OUTPUT FILE
 LOAD SWITCHES USED.....S1,S2,S5,S7,S8,S11,AUX S1,
 AUX S4
 PHASES USED.....1,2,4,5,6,8
 OVERLAP "A".....1+2
 OVERLAP "B".....NOT USED
 OVERLAP "C".....5+6
 OVERLAP "D".....NOT USED

SIGNAL HEAD HOOK-UP CHART

LOAD SWITCH NO.	S1	S2	S3	S4	S5	S6	S7	S8	S9	S10	S11	S12	AUX S1	AUX S2	AUX S3	AUX S4	AUX S5	AUX S6
CMU CHANNEL NO.	1	2	13	3	4	14	5	6	15	7	8	16	9	10	17	11	12	18
PHASE	1	2	2 PED	3	4	4 PED	5	6	6 PED	7	8	8 PED	OLA	OLB	SPARE	OLC	OLD	SPARE
SIGNAL HEAD NO.	11	82	21,22	NU	41,42	NU	42	51	61,62	NU	81,82	NU	11	NU	NU	51	NU	NU
RED	*	128			101		*	134		107								
YELLOW		129			102			135		108								
GREEN		130			103			136		109								
RED ARROW													A121				A114	
YELLOW ARROW	126							132					A122				A115	
FLASHING YELLOW ARROW													A123				A116	
GREEN ARROW	127	127					133	133										

NU = Not Used

* Denotes install load resistor. See load resistor installation detail this sheet.

★ See pictorial of head wiring in detail this sheet.

INPUT FILE POSITION LAYOUT

(front view)

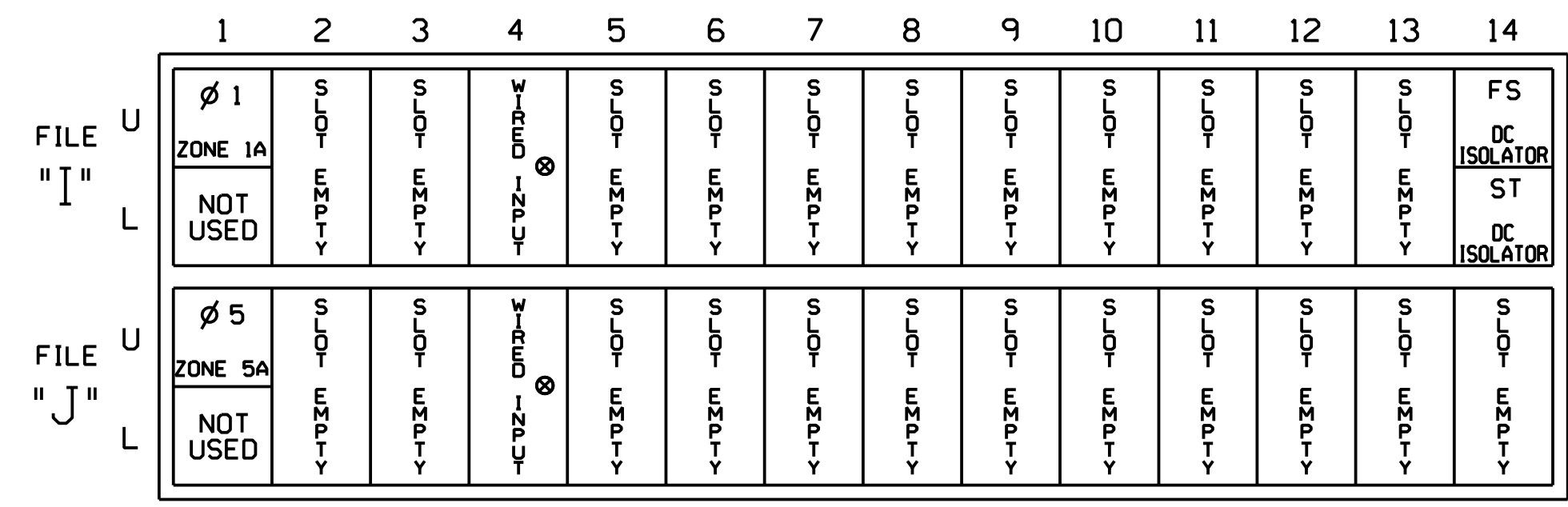

EX.: 1A, 2A, ETC. = LOOP NO.'S

FS = FLASH SENSE
 ST = STOP TIME

⊗ Wired Input - Do not populate slot with detector card

INPUT FILE CONNECTION & PROGRAMMING CHART

LOOP NO.	LOOP TERMINAL	INPUT FILE POS.	PIN NO.	INPUT ASSIGNMENT NO.	DETECTOR NO.	NEMA PHASE	CALL	EXTEND	FULL TIME DELAY	STRETCH TIME	DELAY TIME
ZONE 1A ¹	★★	I1U	56	18	1	1	Y	Y			15
	-	J4U	48	10★	26	6	Y	Y	Y		3
ZONE 5A ²	★★	J1U	55	17	5	5	Y	Y			15
	-	I4U	47	9★	22	2	Y	Y	Y		3

¹Add jumper from I1-W to J4-W, on rear of input file.

²Add jumper from J1-W to I4-W, on rear of input file.

* See Input Page Assignment programming details on sheets 3 and 4.

★★ Multizone Microwave Detector Zone. See Special Detector Note.

INPUT FILE POSITION LEGEND: J2L

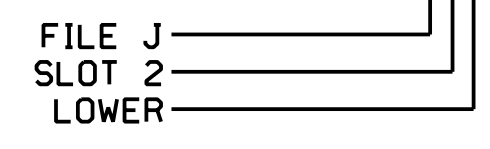

SPECIAL DETECTOR NOTE

Install a microwave detection system for vehicle detection. Perform installation according to manufacturer's directions and NCDOT engineer-approved mounting locations to accomplish the detection schemes shown on the Signal Design Plans.

For loops 1A and 5A detector card placement and slots reserved for wired inputs are typical for a NCDOT installation. Inputs associated with these slots are compatible with the time of day instructions located on sheets 3, 4, and 5 of this electrical detail.

FYA SIGNAL WIRING DETAIL

(wire signal heads as shown)

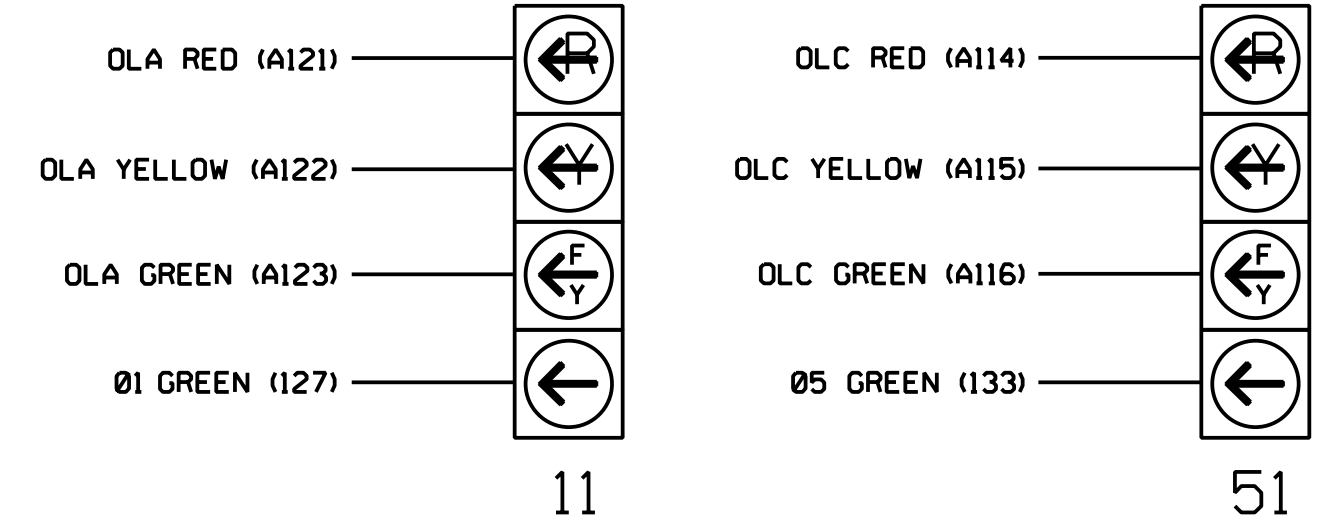

NOTE

The sequence display for signal heads 11 and 51 requires special logic programming. See sheet 2 for programming instructions.

LOAD RESISTOR INSTALLATION DETAIL

(install resistors as shown)

VALUE (ohms)	WATTAGE
1.5K - 1.9K	25W (min)
2.0K - 3.0K	10W (min)

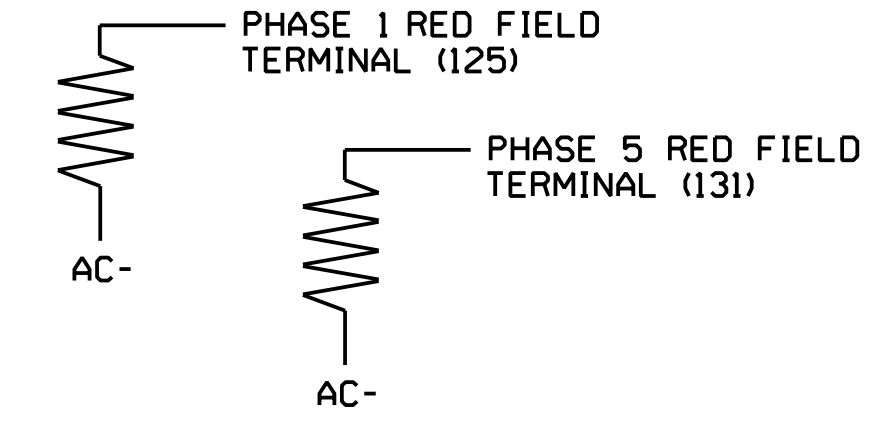

Electrical Detail - Sheet 1 of 5
 New Installation
 Temporary Design 2

DOCUMENT NOT CONSIDERED FINAL UNLESS ALL SIGNATURES COMPLETED

Prepared for:

NC 906 (Midway Road) at NC 211 Northbound Ramp/ Midway Commons Driveway		
Division 03 Brunswick Co.	Southport	
PLAN DATE: June 2017	REVIEWED BY: A.D. Klinksiek	
PREPARED BY: A.H. Thornburg	REVIEWED BY: N.R. Simmons	
REVISIONS	INIT.	DATE

SEAL

HNTB
 HNTB NORTH CAROLINA, P.C.
 343 E. Six Forks Road, Suite 200
 Raleigh, North Carolina 27609
 NC License No: C-1554
 (919) 546-8997

DocuSigned by:
 Natasha Simmons
 9/10/2021
 SIGNATURE DATE
 SIG. INVENTORY NO. 03-1122T2

LOGICAL I/O PROCESSOR PROGRAMMING DETAIL TO PRODUCE SPECIAL FYA-PPLT SIGNAL SEQUENCE

(program controller as shown below)

- FROM MAIN MENU PRESS '2' (PHASE CONTROL), THEN '1' (PHASE CONTROL FUNCTIONS). SCROLL TO THE BOTTOM OF THE MENU AND ENABLE ACT LOGIC COMMANDS 1, 2, 3, 4, 5, AND 6.
- FROM MAIN MENU PRESS '6' (OUTPUTS), THEN '3' (LOGICAL I/O PROCESSOR).

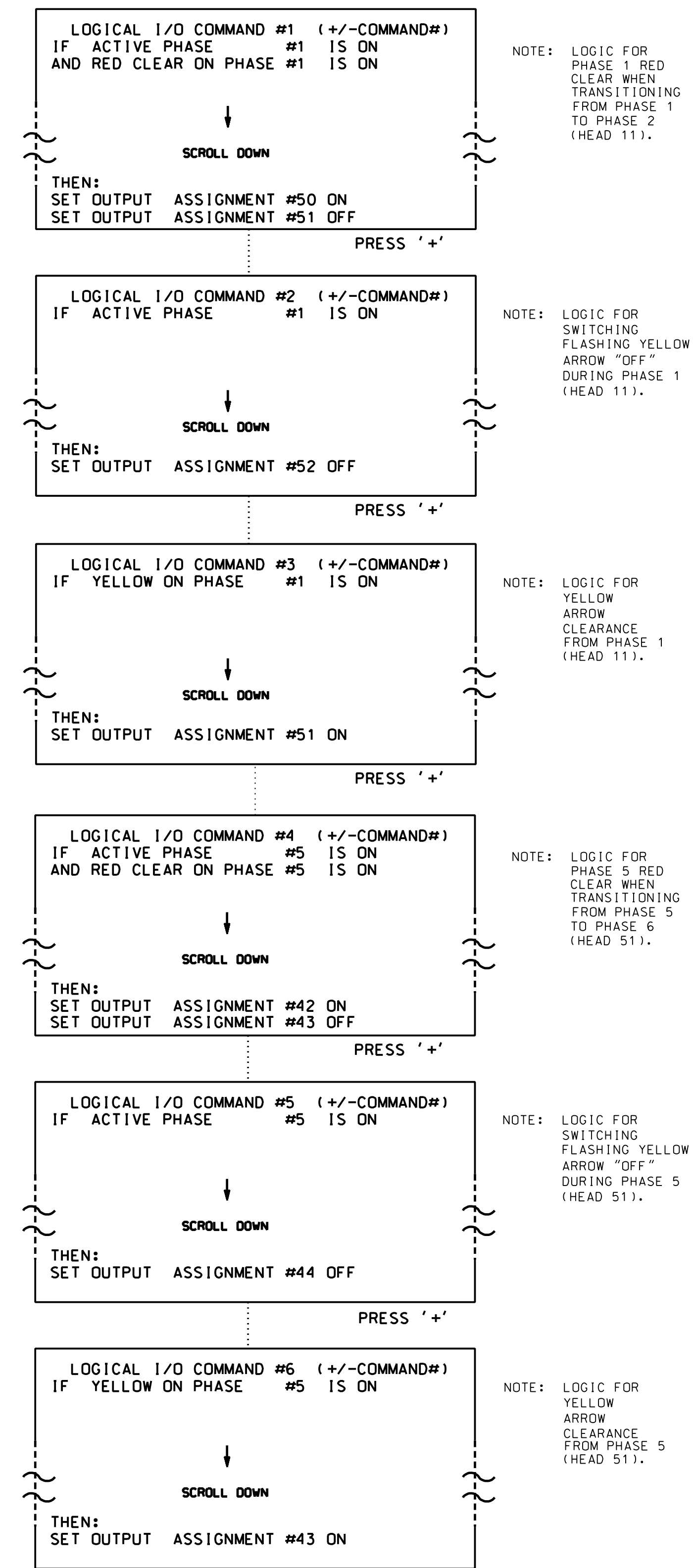

LOGIC I/O PROCESSOR PROGRAMMING COMPLETE

OUTPUT REFERENCE SCHEDULE	
USE TO INTERPRET LOGIC PROCESSOR	
OUTPUT 42 =	Overlap C Red
OUTPUT 43 =	Overlap C Yellow
OUTPUT 44 =	Overlap C Green
OUTPUT 50 =	Overlap A Red
OUTPUT 51 =	Overlap A Yellow
OUTPUT 52 =	Overlap A Green

OVERLAP PROGRAMMING DETAIL FOR DEFAULT PHASING

(program controller as shown below)

FROM MAIN MENU PRESS '8' (OVERLAPS), THEN '1' (VEHICLE OVERLAP SETTINGS).

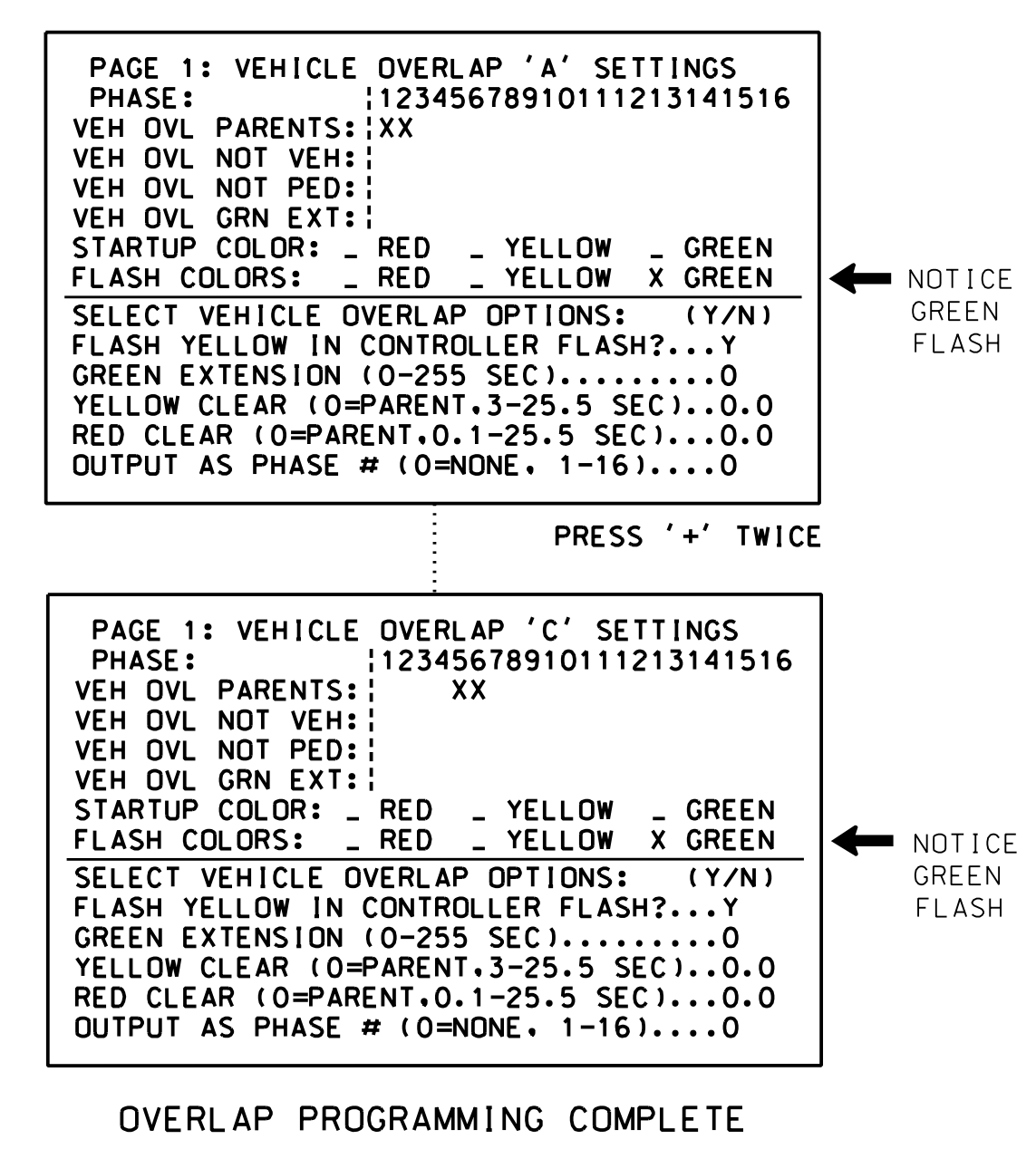

OVERLAP PROGRAMMING DETAIL FOR ALTERNATE PHASING

(program controller as shown below)

FROM MAIN MENU PRESS '8' (OVERLAPS), THEN '1' (VEHICLE OVERLAP SETTINGS). PRESS 'NEXT' TO ADVANCE TO PAGE 2.

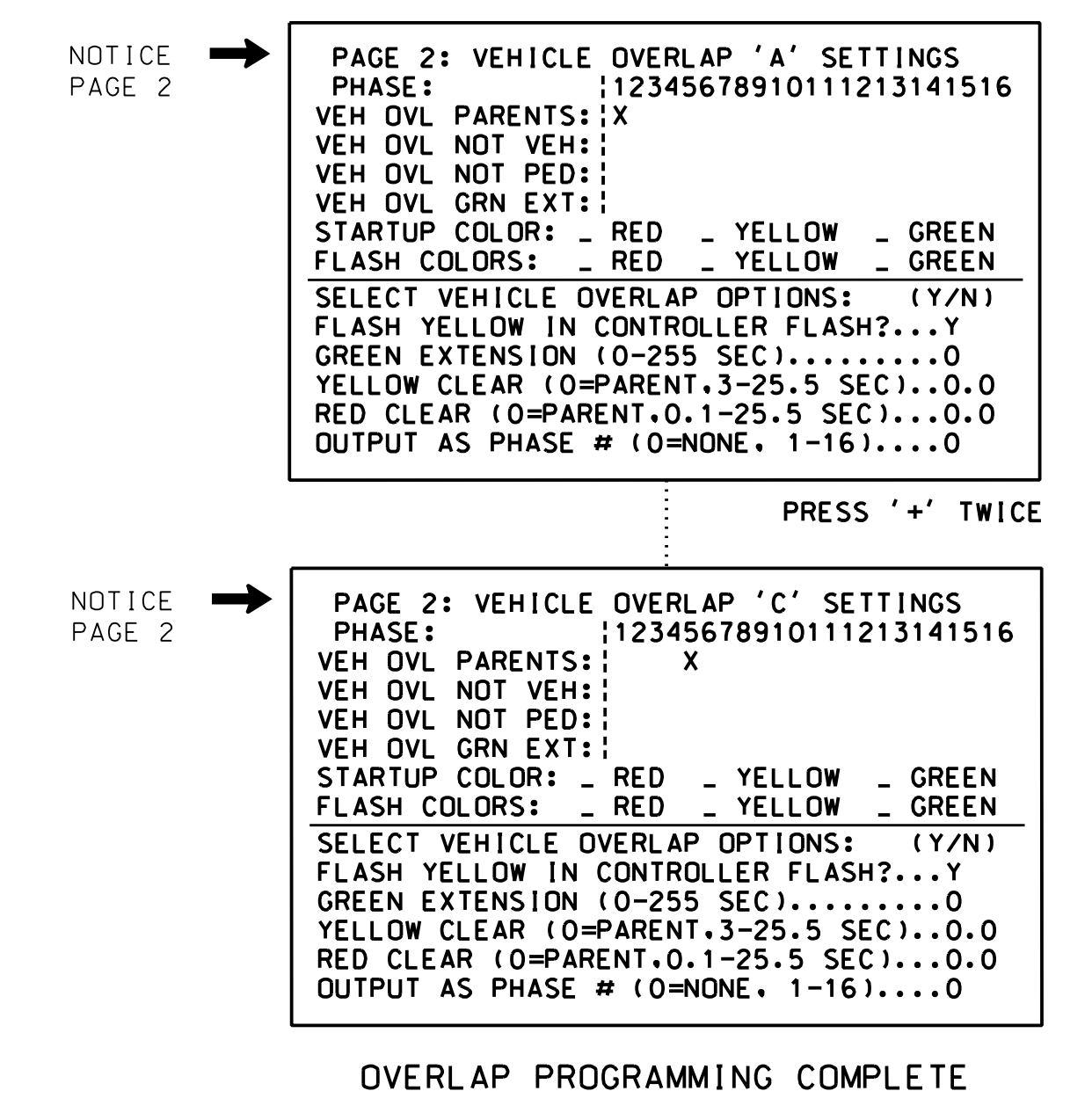

Electrical Detail - Sheet 2 of 5
 New Installation
 Temporary Design 2

DOCUMENT NOT CONSIDERED FINAL
 UNLESS ALL SIGNATURES COMPLETED

THIS ELECTRICAL DETAIL IS FOR
 THE SIGNAL DESIGN: 03-1122T2
 DESIGNED: June 2017
 SEALED: 9/10/2021
 REVISED: N/A

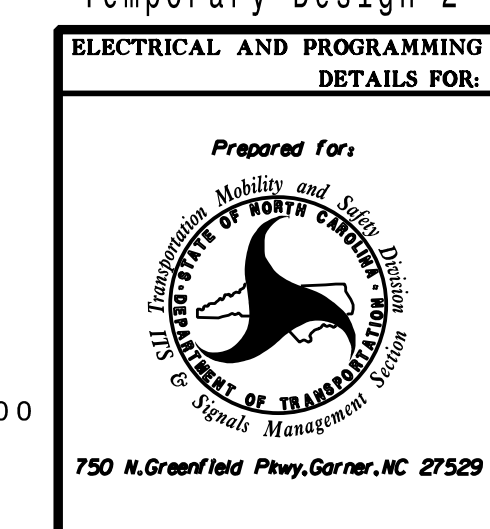

NC 906 (Midway Road) at NC 211 Northbound Ramp/ Midway Commons Driveway		
Division 03	Brunswick Co. Southport	
PLAN DATE: June 2017	REVIEWED BY: A.D. Klinksiek	
PREPARED BY: A.H. Thornburg	REVIEWED BY: N.R. Simmons	
REVISIONS	INIT.	DATE

SEAL
 NORTH CAROLINA
 PROFESSIONAL
 SEAL
 031464
 NATASHA R. SIMMONS
 ENGINEER
 9/10/2021
 SIGNATURE DATE
 SIG. INVENTORY NO. 03-1122T2

HNTB
 HNTB NORTH CAROLINA, P.C.
 343 E. Six Forks Road, Suite 200
 Raleigh, North Carolina 27609
 NC License No: C-1554
 (919) 546-8997

INPUT PAGE 2 ASSIGNMENT PROGRAMMING DETAIL FOR ALTERNATE PHASING - LOOP 1A

(program controller as shown below)

- NOTES: 1. THIS PROGRAMMING APPLIES FOR INPUT PAGE 2 ONLY. INPUT PAGE 1 WILL USE STANDARD DEFAULT SETTINGS. THIS PROGRAMMING IS NECESSARY FOR PROPER DETECTOR OPERATION DURING ALTERNATE PHASING OPERATION. 2. THE FIRST TASK THIS PROGRAMMING ACCOMPLISHES IS THE DISABLING OF INPUT #10 (DETECTOR 26) SO THAT A VEHICLE CALL WILL NOT BE PLACED TO PHASE 6 DURING ALTERNATE PHASING OPERATION. THE SECOND TASK THIS PROGRAMMING ACCOMPLISHES IS THAT IT REASSIGNS DETECTOR 51 TO INPUT #18 SO THAT THE DELAY ON LOOP 1A CAN BE REDUCED FROM 15 SECONDS TO 3 SECONDS.

FROM MAIN MENU PRESS '5' (INPUTS), THEN PRESS 'NEXT' TO GET TO INPUT PAGE '2'. PRESS THE '+' KEY UNTIL INPUT 10 IS REACHED.

PAGE: 2 C1 PIN:48 VEHICLE DETECTOR INPUT ASSIGNMENT #.....10 DEBOUNCE TIME (0-25.5 SEC).....0.5 DELAY TIME (0-25.5 SEC).....0.0 HOLD-OVER TIME (0-25.5 SEC).....0.0 ASSIGNMENT SELECTION: NOT ENABLED (Y/N).....Y VEHICLE DETECTOR (1-64).....26 PEDESTRIAN DETECTOR (1-16)..... ALTERNATE PED DETECTOR (1-16)..... PREEMPT (1-10)..... INVERTED PREEMPT (1-10)..... STOP TIME (Y/N)..... FLASH SENSE (Y/N)..... DOOR OPEN (Y/N)..... MANUAL CONTROL ENABLE (Y/N)..... MANUAL CONTROL ADVANCE (Y/N)..... SPECIAL FUNCTION ALARM (1-8)..... TOD HOUR SYNCHRONIZATION (0-23)..... FORCE OFF RING (1-4)..... HOLD PHASES (1-16)..... PLAN (65=FLSH,66=FREE)..... OFFSET#..... CHANGE PHASE SEQUENCE PAGE (1-12)..... CHANGE PHASE TIMING PAGE (1-4)..... CHANGE PHASE CONTROL PAGE (1-4)..... CHANGE OVERLAP CONTROL PAGE (1-4)..... CHANGE INPUT PAGE (1-4)..... CHANGE OUTPUT PAGE (1-4)..... OVERRIDE PHASE CONTROL FUNCTION (Y).....

ENTER A 'Y' FOR NOT ENABLED
DEFAULT DETECTOR NUMBER WILL REMAIN UNTIL 'NOT ENABLED' IS ENTERED.
(LOOP 1A - PHASE 6)

PAGE: 2 C1 PIN:48 NOT ENABLED INPUT ASSIGNMENT #.....10 DEBOUNCE TIME (0-25.5 SEC).....0.5 DELAY TIME (0-25.5 SEC).....0.0 HOLD-OVER TIME (0-25.5 SEC).....0.0 ASSIGNMENT SELECTION: NOT ENABLED (Y/N).....Y VEHICLE DETECTOR (1-64)..... PEDESTRIAN DETECTOR (1-16)..... ALTERNATE PED DETECTOR (1-16)..... PREEMPT (1-10)..... INVERTED PREEMPT (1-10)..... STOP TIME (Y/N)..... FLASH SENSE (Y/N)..... DOOR OPEN (Y/N)..... MANUAL CONTROL ENABLE (Y/N)..... MANUAL CONTROL ADVANCE (Y/N)..... SPECIAL FUNCTION ALARM (1-8)..... TOD HOUR SYNCHRONIZATION (0-23)..... FORCE OFF RING (1-4)..... HOLD PHASES (1-16)..... PLAN (65=FLSH,66=FREE)..... OFFSET#..... CHANGE PHASE SEQUENCE PAGE (1-12)..... CHANGE PHASE TIMING PAGE (1-4)..... CHANGE PHASE CONTROL PAGE (1-4)..... CHANGE OVERLAP CONTROL PAGE (1-4)..... CHANGE INPUT PAGE (1-4)..... CHANGE OUTPUT PAGE (1-4)..... OVERRIDE PHASE CONTROL FUNCTION (Y).....

PRESS '+' TO ADVANCE TO INPUT 18

PAGE: 2 C1 PIN:56 VEHICLE DETECTOR INPUT ASSIGNMENT #.....18 DEBOUNCE TIME (0-25.5 SEC).....0.5 DELAY TIME (0-25.5 SEC).....0.0 HOLD-OVER TIME (0-25.5 SEC).....0.0 ASSIGNMENT SELECTION: NOT ENABLED (Y/N)..... VEHICLE DETECTOR (1-64).....1 PEDESTRIAN DETECTOR (1-16)..... ALTERNATE PED DETECTOR (1-16)..... PREEMPT (1-10)..... INVERTED PREEMPT (1-10)..... STOP TIME (Y/N)..... FLASH SENSE (Y/N)..... DOOR OPEN (Y/N)..... MANUAL CONTROL ENABLE (Y/N)..... MANUAL CONTROL ADVANCE (Y/N)..... SPECIAL FUNCTION ALARM (1-8)..... TOD HOUR SYNCHRONIZATION (0-23)..... FORCE OFF RING (1-4)..... HOLD PHASES (1-16)..... PLAN (65=FLSH,66=FREE)..... OFFSET#..... CHANGE PHASE SEQUENCE PAGE (1-12)..... CHANGE PHASE TIMING PAGE (1-4)..... CHANGE PHASE CONTROL PAGE (1-4)..... CHANGE OVERLAP CONTROL PAGE (1-4)..... CHANGE INPUT PAGE (1-4)..... CHANGE OUTPUT PAGE (1-4)..... OVERRIDE PHASE CONTROL FUNCTION (Y).....

ENTER '51' TO REASSIGN THE VEHICLE DETECTOR FOR THIS INPUT
(LOOP 1A - PHASE 1)

PAGE: 2 C1 PIN:56 VEHICLE DETECTOR INPUT ASSIGNMENT #.....18 DEBOUNCE TIME (0-25.5 SEC).....0.5 DELAY TIME (0-25.5 SEC).....0.0 HOLD-OVER TIME (0-25.5 SEC).....0.0 ASSIGNMENT SELECTION: NOT ENABLED (Y/N)..... VEHICLE DETECTOR (1-64).....51 PEDESTRIAN DETECTOR (1-16)..... ALTERNATE PED DETECTOR (1-16)..... PREEMPT (1-10)..... INVERTED PREEMPT (1-10)..... STOP TIME (Y/N)..... FLASH SENSE (Y/N)..... DOOR OPEN (Y/N)..... MANUAL CONTROL ENABLE (Y/N)..... MANUAL CONTROL ADVANCE (Y/N)..... SPECIAL FUNCTION ALARM (1-8)..... TOD HOUR SYNCHRONIZATION (0-23)..... FORCE OFF RING (1-4)..... HOLD PHASES (1-16)..... PLAN (65=FLSH,66=FREE)..... OFFSET#..... CHANGE PHASE SEQUENCE PAGE (1-12)..... CHANGE PHASE TIMING PAGE (1-4)..... CHANGE PHASE CONTROL PAGE (1-4)..... CHANGE OVERLAP CONTROL PAGE (1-4)..... CHANGE INPUT PAGE (1-4)..... CHANGE OUTPUT PAGE (1-4)..... OVERRIDE PHASE CONTROL FUNCTION (Y).....

PROGRAMMING COMPLETE

SPECIAL DETECTOR PROGRAMMING DETAIL - LOOP 1A (ALT.)

(program controller as shown below)

FROM MAIN MENU PRESS '7' (DETECTORS), THEN PRESS '1' FOR VEHICLE DETECTORS. PRESS THE '-' KEY TO GET TO VEHICLE DETECTOR #51.

VEHICLE DETECTOR #51 SETTINGS (+,-,1-64) SETTING: (Y/N) ENABLE DETECTOR.....N ENABLE LOGGING.....N ENABLE DIAGNOSTICS.....N SPEED TRAP.....N CALL DETECTOR.....Y EXTENSION DETECTOR.....Y MODE 2 STOP BAR.....N SWITCHING DETECTOR.....N DUPLICATING DETECTOR.....N ENABLE FULL TIME DELAY.....N IF FAILED, SET MIN RECALL?.....N IF FAILED, SET MAX1 RECALL?.....N IF FAILED, SET MAX2 RECALL?.....N PHASE# ;12345678910111213141516 PHASES ASSIGNED ; SWITCH/DUPLICATE; LOOP SIZE (0-255 FT).....6 SPEED TRAP DISTANCE (0-255 FT).....0 STOP BAR TIME (0-255 SEC).....0 STRETCH (0-25.5 SEC).....0.0 DELAY (0-255 SEC).....0 MAX CALLS/MIN (0-255).....255 MIN CALLS/DIAGNOSTIC PERIOD (0-255).....0 MAX OCCUPANCY (0-100%).....100 EXTENSION DISABLE TIME (0-255 SEC).....0 QUEUE MAX OCCUPANCY TIME (0-255).....0 QUEUE GAP RESET TIME (0-25.5).....0.0 PREEMPTION INDEX FOR QUEUE (0-10).....0

ENTER 'Y' FOR ENABLE DETECTOR
ENTER '1' FOR PHASES ASSIGNED
ENSURE DELAY IS '3'

VEHICLE DETECTOR #51 SETTINGS (+,-,1-64) SETTING: (Y/N) ENABLE DETECTOR.....Y ENABLE LOGGING.....N ENABLE DIAGNOSTICS.....N SPEED TRAP.....N CALL DETECTOR.....Y EXTENSION DETECTOR.....Y MODE 2 STOP BAR.....N SWITCHING DETECTOR.....N DUPLICATING DETECTOR.....N ENABLE FULL TIME DELAY.....N IF FAILED, SET MIN RECALL?.....N IF FAILED, SET MAX1 RECALL?.....N IF FAILED, SET MAX2 RECALL?.....N PHASE# ;12345678910111213141516 PHASES ASSIGNED ;X SWITCH/DUPLICATE; LOOP SIZE (0-255 FT).....6 SPEED TRAP DISTANCE (0-255 FT).....0 STOP BAR TIME (0-255 SEC).....0 STRETCH (0-25.5 SEC).....0.0 DELAY (0-255 SEC).....3 MAX CALLS/MIN (0-255).....255 MIN CALLS/DIAGNOSTIC PERIOD (0-255).....0 MAX OCCUPANCY (0-100%).....100 EXTENSION DISABLE TIME (0-255 SEC).....0 QUEUE MAX OCCUPANCY TIME (0-255).....0 QUEUE GAP RESET TIME (0-25.5).....0.0 PREEMPTION INDEX FOR QUEUE (0-10).....0

DETECTOR PROGRAMMING COMPLETE

NOTE: DETECTOR IS PROGRAMMED PER THE INPUT FILE CONNECTION AND PROGRAMMING CHART SHOWN ON SHEET 1.

THIS ELECTRICAL DETAIL IS FOR THE SIGNAL DESIGN: 03-1122T2 DESIGNED: June 2017 SEALED: 9/10/2021 REVISED: N/A

Electrical Detail - Sheet 3 of 5
New Installation
Temporary Design 2

DOCUMENT NOT CONSIDERED FINAL UNLESS ALL SIGNATURES COMPLETED

Table with project details: NC 906 (Midway Road) at NC 211 Northbound Ramp/Midway Commons Driveway. Includes fields for Division 03, Brunswick Co., Southport, Plan Date: June 2017, Prepared by: A.H. Thornburg, Reviewed by: N.R. Simmons, and a signature block for Natasha R. Simmons, Engineer, Seal 031464, dated 9/10/2021.

INPUT PAGE 2 ASSIGNMENT PROGRAMMING DETAIL FOR ALTERNATE PHASING - LOOP 5A

(program controller as shown below)

- NOTES: 1. THIS PROGRAMMING APPLIES FOR INPUT PAGE 2 ONLY. INPUT PAGE 1 WILL USE STANDARD DEFAULT SETTINGS. THIS PROGRAMMING IS NECESSARY FOR PROPER DETECTOR OPERATION DURING ALTERNATE PHASING OPERATION.
2. THE FIRST TASK THIS PROGRAMMING ACCOMPLISHES IS THE DISABLING OF INPUT #9 (DETECTOR 22) SO THAT A VEHICLE CALL WILL NOT BE PLACED TO PHASE 2 DURING ALTERNATE PHASING OPERATION. THE SECOND TASK THIS PROGRAMMING ACCOMPLISHES IS THAT IT REASSIGNS DETECTOR 55 TO INPUT #17 SO THAT THE DELAY ON LOOP 5A CAN BE REDUCED FROM 15 SECONDS TO 3 SECONDS.

FROM MAIN MENU PRESS '5' (INPUTS), THEN PRESS 'NEXT' TO GET TO INPUT PAGE '2'. PRESS THE '+' KEY UNTIL INPUT 9 IS REACHED.

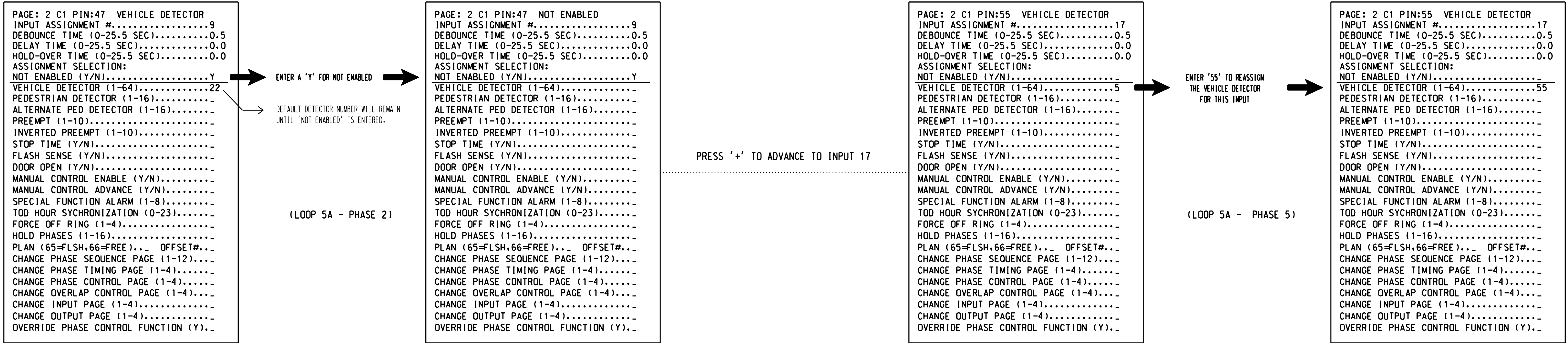

SPECIAL DETECTOR PROGRAMMING DETAIL - LOOP 5A (ALT.)

(program controller as shown below)

FROM MAIN MENU PRESS '7' (DETECTORS), THEN PRESS '1' FOR VEHICLE DETECTORS. PRESS THE '-' KEY TO GET TO VEHICLE DETECTOR #55.

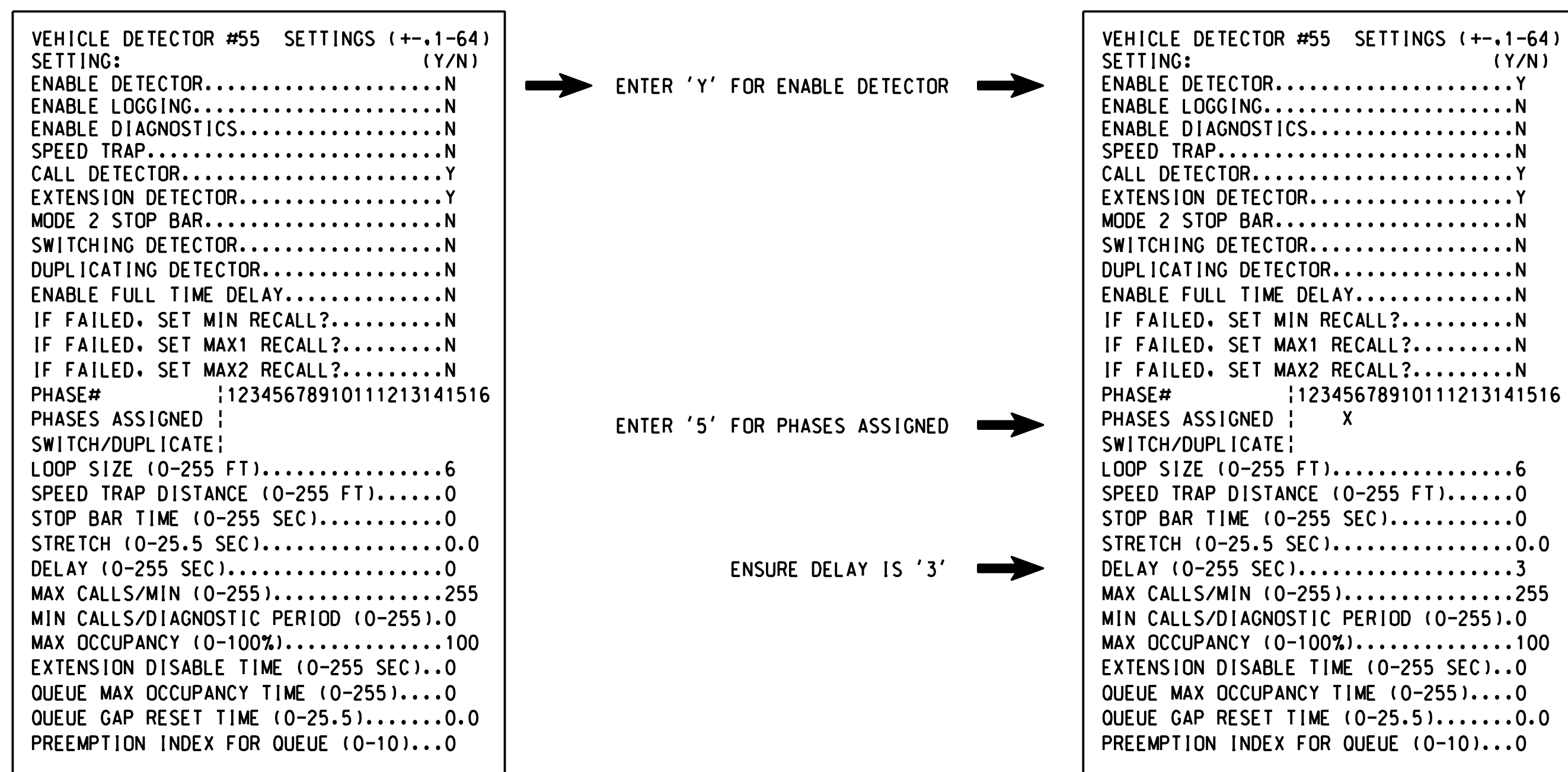

NOTE: DETECTOR IS PROGRAMMED PER THE INPUT FILE CONNECTION AND PROGRAMMING CHART SHOWN ON SHEET 1.

THIS ELECTRICAL DETAIL IS FOR THE SIGNAL DESIGN: 03-1122T2
 DESIGNED: June 2017
 SEALED: 9/10/2021
 REVISED: N/A

Electrical Detail - Sheet 4 of 5
 New Installation
 Temporary Design 2

DOCUMENT NOT CONSIDERED FINAL UNLESS ALL SIGNATURES COMPLETED

	Prepared for: Department of Transportation Division of Traffic Engineering State of North Carolina		
	NC 906 (Midway Road) at NC 211 Northbound Ramp/ Midway Commons Driveway	Division 03 Brunswick Co. Southport	
PLAN DATE: June 2017 PREPARED BY: A.H. Thornburg	REVIEWED BY: A.D. Klinksiek REVIEWED BY: N.R. Simmons	REVISIONS INIT. DATE	Signature: <i>Natasha Simmons</i> DATE: 9/10/2021 SIG. INVENTORY NO. 03-1122T2

ALTERNATE PHASING ACTIVATION DETAIL

TO RUN ALT. PHASING DURING COORDINATION - SELECT ALL PAGE CHANGES (AS SHOWN BELOW) WITHIN COORDINATION PLAN PROGRAMMING.

TO RUN ALT. PHASING DURING FREE RUN - PROGRAM PAGE CHANGES (SHOWN BELOW) IN SEPARATE TIME OF DAY EVENTS. IF PAGE 1 IS USED, NO EVENT PROGRAMMING IS NECESSARY FOR THAT PARTICULAR PAGE.

<u>PHASING</u>	<u>INPUTS PAGE</u>	<u>OVERLAPS PAGE</u>
ACTIVE PAGES REQUIRED TO RUN <u>DEFAULT PHASING</u>	1	1
ACTIVE PAGES REQUIRED TO RUN <u>ALTERNATE PHASING</u>	2	2

NOTE: PAGES NOT SHOWN (i.e. sequence, phase control, etc.) SHOULD REMAIN AS '1', OR AS DEFINED BY TIMING ENGINEER.

IMPORTANT: IF ALT. PHASING IS USED DURING FREE RUN AND COORDINATION, DO NOT OPERATE TIME OF DAY PAGE CHANGE EVENTS CONCURRENTLY WITH COORDINATION PLAN EVENTS IN THE EVENT SCHEDULER. (EX. FREE RUN PAGE CHANGE EVENT SHOULD END BEFORE COORDINATION PLAN EVENT STARTS AND VICE-VERSA).

ALTERNATE PHASING PAGE CHANGE SUMMARY

THE FOLLOWING IS A SUMMARY OF WHAT TAKES PLACE WHEN THESE OVERLAP/INPUT PAGE CHANGES ACTIVATE TO CALL THE "ALTERNATE PHASING":

OVERLAPS PAGE 2: Modifies overlap parent phases for heads 11 and 51 to run protected turns only.

INPUTS PAGE 2: Disables phase 6 call on loop 1A and reduces delay time for phase 1 call on loop 1A to 3 seconds.

Disables phase 2 call on loop 5A and reduces delay time for phase 5 call on loop 5A to 3 seconds.

THIS ELECTRICAL DETAIL IS FOR THE SIGNAL DESIGN: 03-1122T2
DESIGNED: June 2017
SEALED: 9/10/2021
REVISED: N/A

Electrical Detail - Sheet 5 of 5
New Installation
Temporary Design 2

**DOCUMENT NOT CONSIDERED FINAL
UNLESS ALL SIGNATURES COMPLETED**

HNTB HNTB NORTH CAROLINA, P.C.
343 E. Six Forks Road, Suite 200
Raleigh, North Carolina 27609
NC License No: C-1554
(919) 546-8997

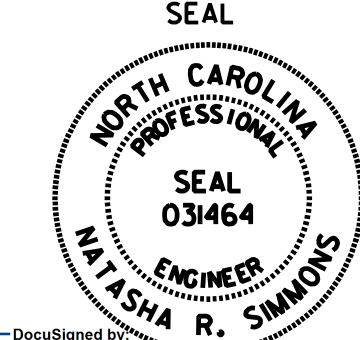
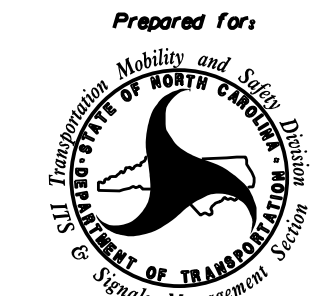
ELECTRICAL AND PROGRAMMING DETAILS FOR:	NC 906 (Midway Road) at NC 211 Northbound Ramp/ Midway Commons Driveway Division 03 Brunswick Co. Southport PLAN DATE: June 2017 REVIEWED BY: A.D. Klinksiek PREPARED BY: A.H. Thornburg REVIEWED BY: N.R. Simmons	SEAL 
	REVISIONS INIT. DATE	DocuSigned by: Natasha Simmons 9/10/2021 SIGNATURE DATE SIG. INVENTORY NO. 03-1122T2

DEFAULT PHASING DIAGRAM

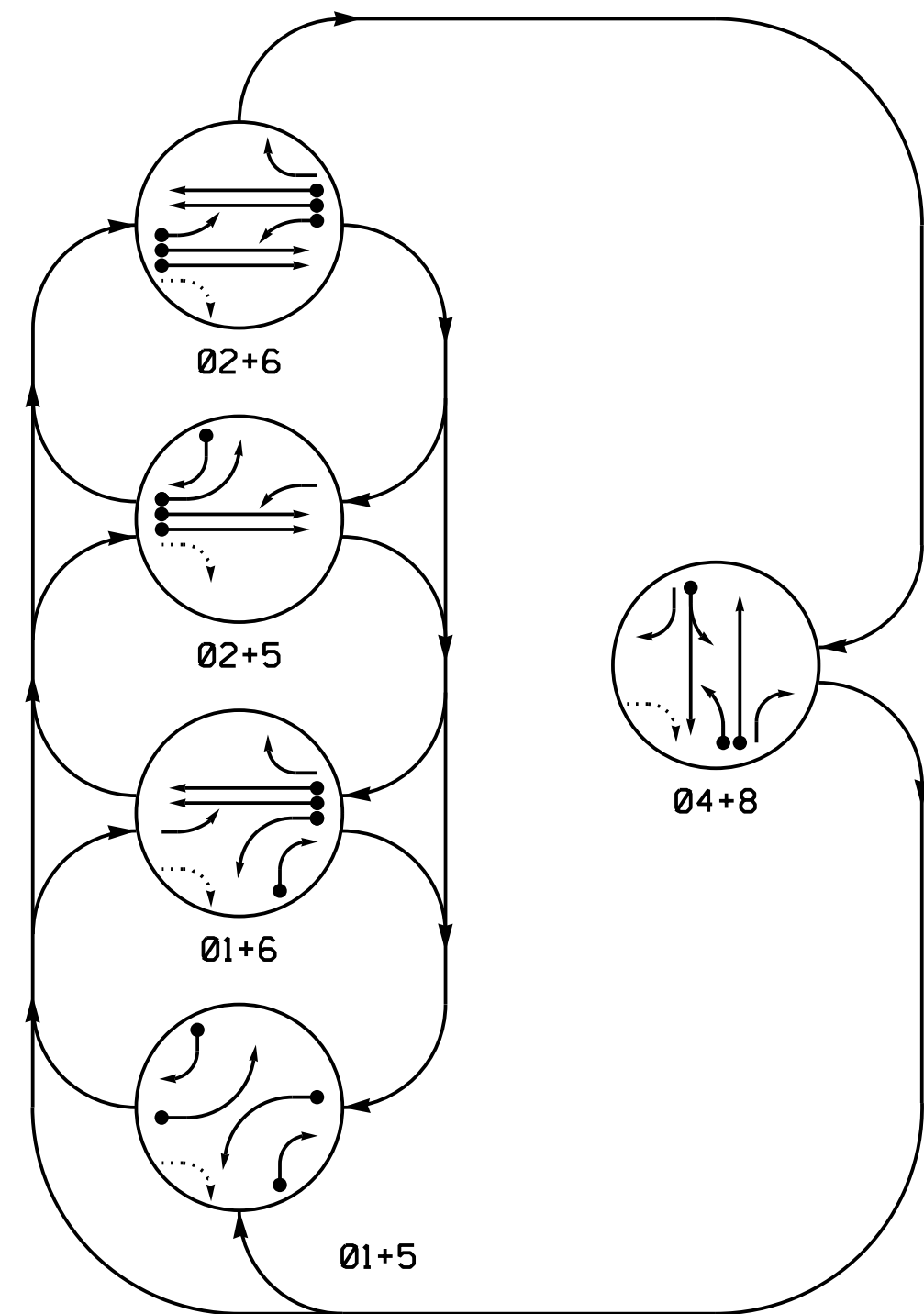

ALTERNATE PHASING DIAGRAM

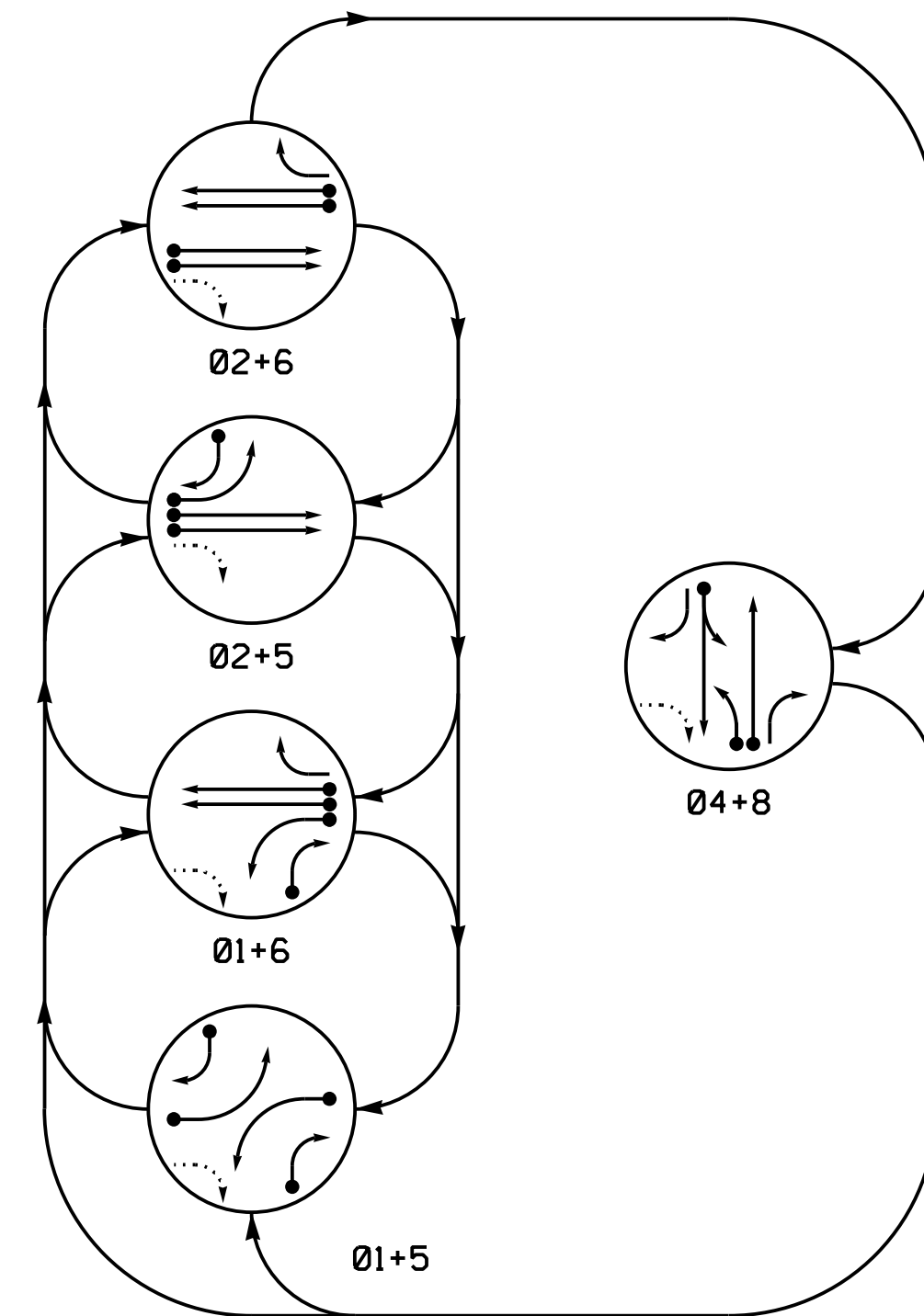

PHASING DIAGRAM DETECTION LEGEND

- DETECTED MOVEMENT
- UNDETECTED MOVEMENT (OVERLAP)
- UNSIGNALIZED MOVEMENT
- PEDESTRIAN MOVEMENT

DEFAULT PHASING TABLE OF OPERATION

SIGNAL FACE	PHASE					
	01+5	01+6	02+5	02+6	04+8	FLASH
11	-	-	F	F	R	Y
21,22	R	R	G	G	R	Y
41,42	R	R	R	R	G	R
43	F	F	F	F	F	R
51	-	F	-	-	F	Y
61,62	R	G	R	G	R	Y
81	R	R	R	R	F	R
82,83,85	R	R	R	R	G	R
84	F	F	R	R	F	R

ALTERNATE PHASING TABLE OF OPERATION

SIGNAL FACE	PHASE					
	01+5	01+6	02+5	02+6	04+8	FLASH
11	-	-	R	R	R	Y
21,22	R	R	G	G	R	Y
41,42	R	R	R	R	G	R
43	F	F	F	F	F	R
51	-	R	-	-	F	Y
61,62	R	G	R	G	R	Y
81	R	R	R	R	F	R
82,83,85	R	R	R	R	G	R
84	F	F	R	R	F	R

OASIS 2070 LOOP & DETECTOR INSTALLATION CHART

LOOP	SIZE (FT)	DISTANCE FROM STOPBAR (FT)	TURNS	NEW LOOP	DETECTOR PROGRAMMING							
					PHASE	CALLING	EXTENSION	FULL TIME DELAY	STRETCH TIME	DELAY TIME	SYSTEM LOOP	NEW CARD
1A	6X40	0	2-4-2	Y	1	Y	Y	-	-	**15	-	Y
1B	6X40	0	2-4-2	Y	1	Y	Y	-	-	15	-	Y
2A/S03	6X6	300	5	Y	2	Y	Y	-	-	-	-	Y
2B/S04	6X6	300	5	Y	2	Y	Y	-	-	-	-	Y
4A	6X40	0	2-4-2	Y	4	Y	Y	-	-	-	-	Y
5A	6X40	0	2-4-2	Y	5	Y	Y	-	-	**15	-	Y
5B	6X40	0	2-4-2	Y	5	Y	Y	-	-	15	-	Y
6A/S05	6X6	300	5	Y	6	Y	Y	-	-	-	-	Y
6B/S06	6X6	300	5	Y	6	Y	Y	-	-	-	-	Y
8A	6X40	0	2-4-2	Y	8	Y	Y	-	-	-	-	Y
8B	6X40	0	2-4-2	Y	8	Y	Y	-	-	-	-	Y

5 Phase Fully Actuated (NC 133 Closed Loop System)

NOTES

- Refer to "Roadway Standard Drawings NCDOT" dated January 2018 and "Standard Specifications for Roads and Structures" dated January 2018.
- Do not program signal for late night flashing operation unless otherwise directed by the Engineer.
- Phase 1 and/or phase 5 may be lagged.
- Set all detector units to presence mode.
- The Division Traffic Engineer will determine the hours of use for each phasing plan.
- Maximum times shown in timing chart are for free-run operation only. Coordinated signal system timing values supersede these values.
- Closed loop system data: Controller Asset #: 1122.

SIGNAL FACE I.D.

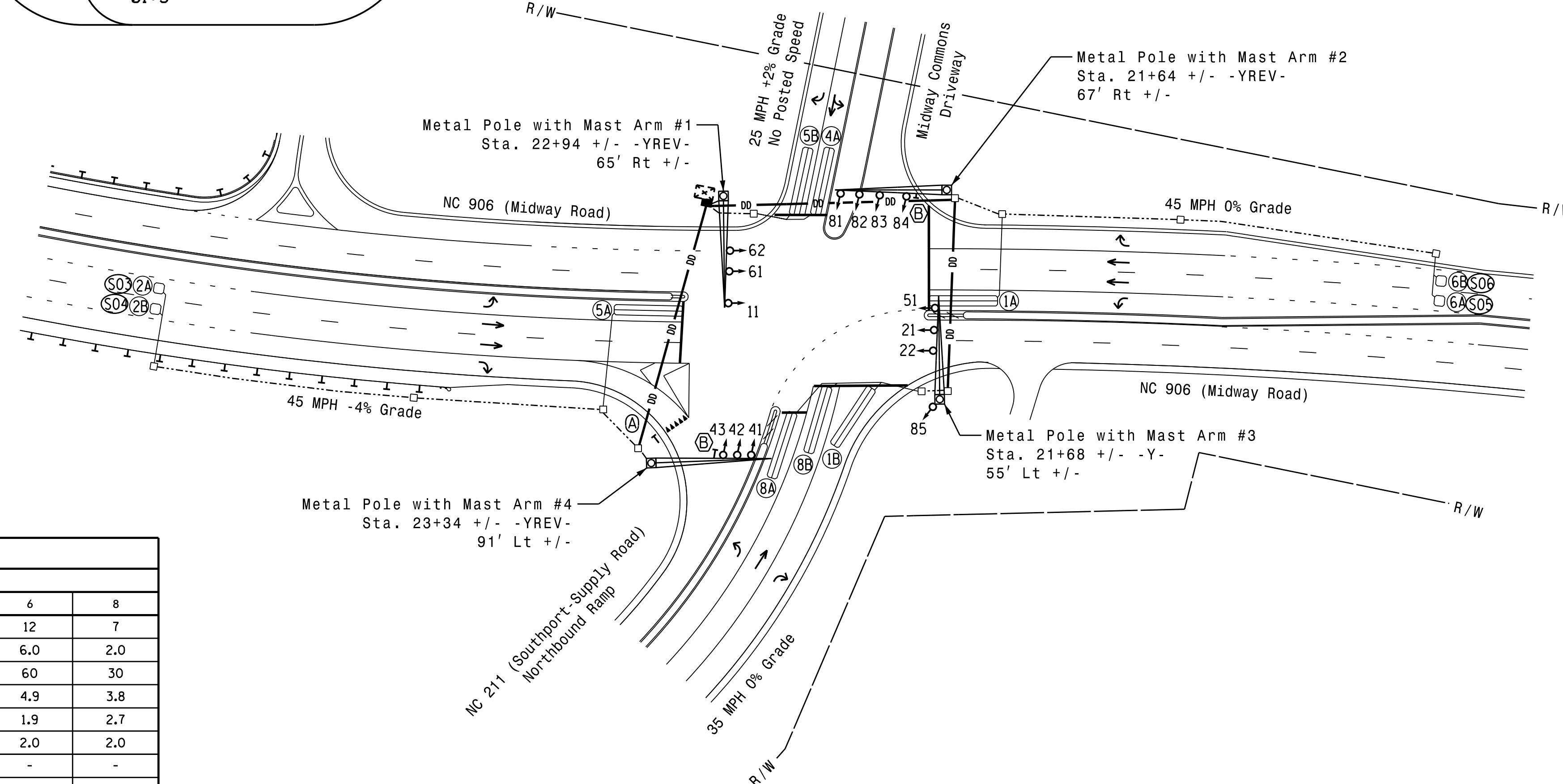
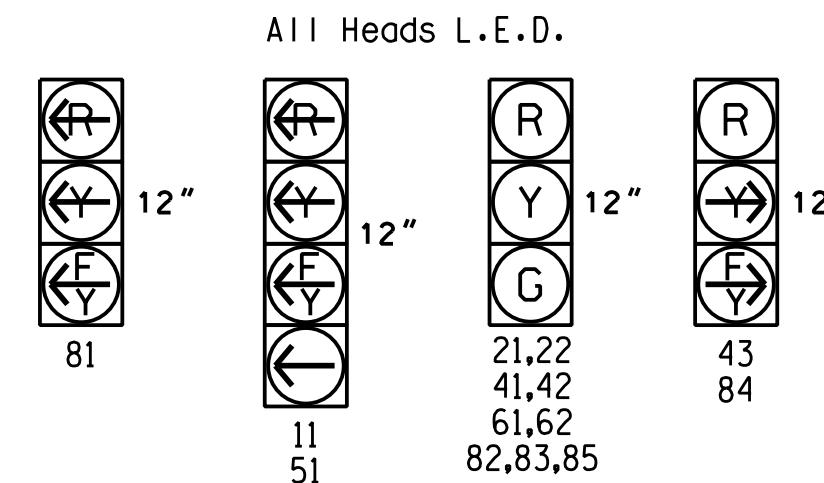

OASIS 2070 TIMING CHART

FEATURE	PHASE					
	1	2	4	5	6	8
Min Green 1 *	7	12	7	7	12	7
Extension 1 *	2.0	6.0	2.0	2.0	6.0	2.0
Max Green 1 *	20	60	30	20	60	30
Yellow Clearance	3.0	4.9	3.8	3.0	4.9	3.8
Red Clearance	3.2	1.9	2.7	3.6	1.9	2.7
Red Revert	2.0	2.0	2.0	2.0	2.0	2.0
Walk 1 *	-	-	-	-	-	-
Don't Walk 1	-	-	-	-	-	-
Seconds Per Actuation *	-	2.5	-	-	2.5	-
Max Variable Initial *	-	34	-	-	34	-
Time Before Reduction *	-	15	-	-	15	-
Time To Reduce *	-	30	-	-	30	-
Minimum Gap	-	3.0	-	-	3.0	-
Recall Mode	-	MIN RECALL	-	-	MIN RECALL	-
Vehicle Call Memory	-	YELLOW	-	-	YELLOW	-
Dual Entry	-	-	ON	-	-	ON
Simultaneous Gap	ON	ON	ON	ON	ON	ON

* These values may be field adjusted. Do not adjust Min Green and Extension times for phases 2 and 6 lower than what is shown. Min Green for all other phases should not be lower than 4 seconds.

LEGEND

PROPOSED	EXISTING

New Installation Final Design

DOCUMENT NOT CONSIDERED FINAL UNLESS ALL SIGNATURES COMPLETED

HNTB NORTH CAROLINA, P.C.
343 E. Six Forks Road, Suite 200
Raleigh, North Carolina 27609
NC License No: C-1554
(919) 546-8997

750 N. Greenfield Place, Garner, NC 27529

NC 906 (Midway Road) at
NC 211 Northbound Ramp/
Midway Commons Driveway

Division 03 Brunswick Co. Southport

PLAN DATE: June 2017 REVIEWED BY: A.D. Klinksiek

PREPARED BY: A.H. Thornburg REVIEWED BY: N.R. Simmons

SCALE: 0 50 1"=50'

SEAL

SEAL 031464

9/10/2021

SIGNATURE DATE

SIG. INVENTORY NO. 03-1122

EDI MODEL 2018ECL-NC CONFLICT MONITOR PROGRAMMING DETAIL

(remove jumpers and set switches as shown)

REMOVE DIODE JUMPERS 1-5, 1-6, 1-9, 1-11, 1-12, 1-17, 2-5, 2-6, 2-9, 2-11, 2-12, 4-8, 4-10, 4-12, 4-17, 5-9, 5-11, 5-12, 5-17, 6-9, 6-11, 6-17, 8-10, 8-12, 8-17, 9-11, 9-12, 9-17, 10-12, 10-17, 11-12, 11-17, and 12-17.

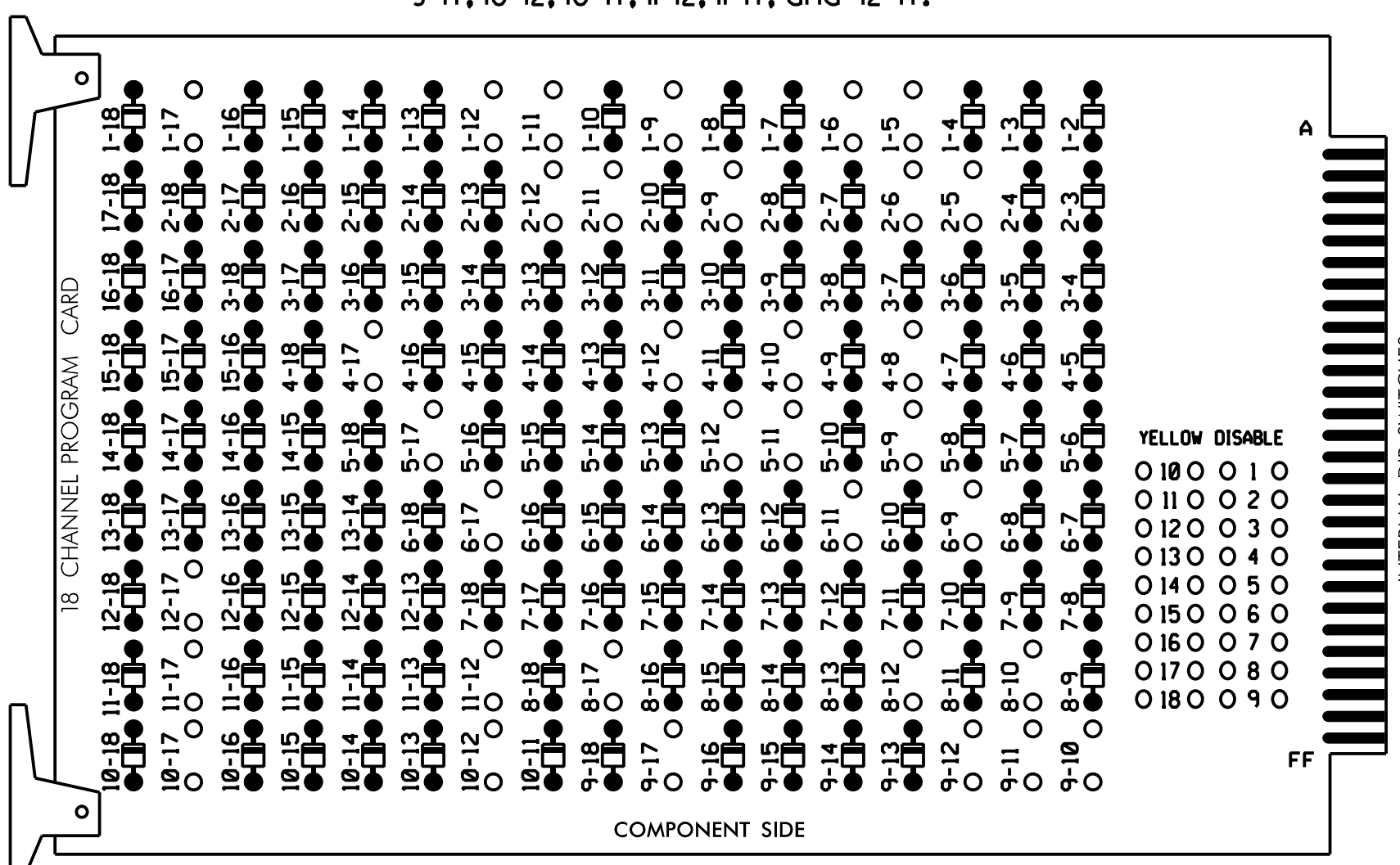

REMOVE JUMPERS AS SHOWN

NOTES:

- Card is provided with all diode jumpers in place. Removal of any jumper allows its channels to run concurrently.
- Ensure jumpers SEL2-SEL5 and SEL9 are present on the monitor board.
- Ensure that Red Enable is active at all times during normal operation.
- Connect serial cable from conflict monitor to comm. port 1 of 2070 controller. Ensure conflict monitor communicates with 2070.

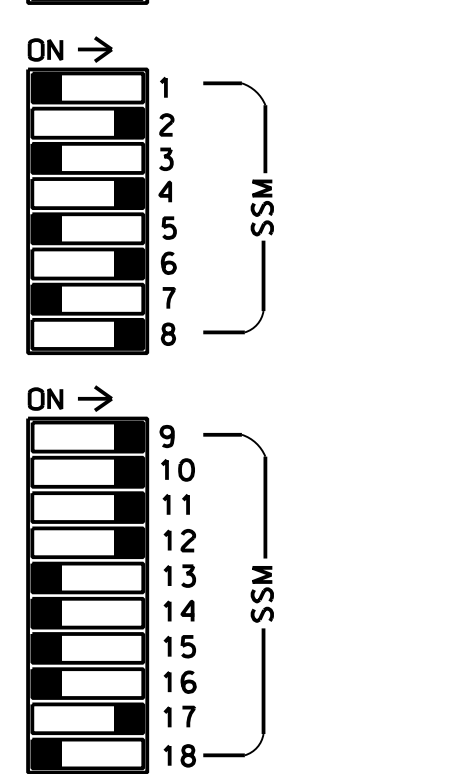
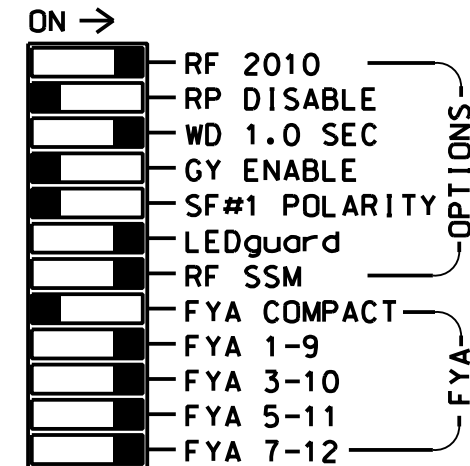
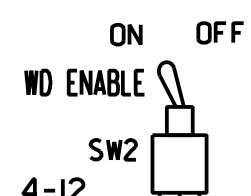

■ = DENOTES POSITION OF SWITCH

NOTES

- To prevent "flash-conflict" problems, insert red flash program blocks for all unused vehicle load switches in the output file. The installer shall verify that signal heads flash in accordance with the Signal Plans.
- Program phases 4 and 8 for Dual Entry.
- Enable Simultaneous Gap-Out for all Phases.
- Program phases 2 and 6 for Variable Initial and Gap Reduction.
- Program phases 2 and 6 for Startup In Green.
- Program phases 2 and 6 for Yellow Flash, and overlaps 1, 2, and 5 as Wag Overlaps.
- If this signal will be managed by an ATMS software, enable controller and detector logging for all detectors used at this location.
- The cabinet and controller are part of the NC 133 Closed Loop System.

EQUIPMENT INFORMATION

CONTROLLER.....2070E
 CABINET.....332 W/AUX
 SOFTWARE.....ECONOLITE OASIS
 CABINET MOUNT.....BASE
 OUTPUT FILE POSITIONS...18 WITH AUX. OUTPUT FILE
 LOAD SWITCHES USED.....S1,S2,S5,S7,S8,S11,AUX S1,
 AUX S2,AUX S3,AUX S4,AUX S5
 PHASES USED.....1,2,4,5,6,8
 OVERLAP "A".....1+2
 OVERLAP "B".....4
 OVERLAP "C".....5+6
 OVERLAP "D".....4+5
 OVERLAP "E".....1+8

SIGNAL HEAD HOOK-UP CHART

LOAD SWITCH NO.	S1	S2	S3	S4	S5	S6	S7	S8	S9	S10	S11	S12	AUX S1	AUX S2	AUX S3	AUX S4	AUX S5	AUX S6
CMU CHANNEL NO.	1	2	13	3	4	14	5	6	15	7	8	16	9	10	17	11	12	18
PHASE	1	2	2 PED	3	4	4 PED	5	6	6 PED	7	8	8 PED	OLA	OLB	OLE	OLC	OLD	SPARE
SIGNAL HEAD NO.	11	21,22	NU	NU	41,42	NU	51	61,62	NU	NU	82,83,85	NU	11	81	84	51	43	NU
RED		128			101			134			107				A111		A101	
YELLOW	*	129			102		*	135			108							
GREEN		130			103			136			109							
RED ARROW													A121	A124			A114	
YELLOW ARROW													A122	A125	A112	A115	A102	
FLASHING YELLOW ARROW													A123	A126	A113	A116	A103	
GREEN ARROW	127							133										

NU = Not Used
 * Denotes install load resistor. See load resistor installation detail this sheet.
 ★ See pictorial of head wiring in detail this sheet.
 NOTE: Load switch AUX S3 requires output remapping. See sheet 6 of this electrical detail for instructions.

INPUT FILE POSITION LAYOUT

(front view)

FILE "I"	1	2	3	4	5	6	7	8	9	10	11	12	13	14	
U	∅ 1	∅ 1	∅ 2/SYS	∅ 3	∅ 4	∅ 5	∅ 6	∅ 7	∅ 8	∅ 9	∅ 10	∅ 11	∅ 12	∅ 13	FS
L	1A	1B	2A/S03	2B/S04	4A	5A	6A/S05	7A	8A	9A	10A	11A	12A	13A	DC ISOLATOR
U	NOT USED	NOT USED	∅ 2/SYS	∅ 3	∅ 4	∅ 5	∅ 6	∅ 7	∅ 8	∅ 9	∅ 10	∅ 11	∅ 12	∅ 13	DC ISOLATOR
L	NOT USED	NOT USED	2B/S04	∅ 3	∅ 4	∅ 5	∅ 6	∅ 7	∅ 8	∅ 9	∅ 10	∅ 11	∅ 12	∅ 13	DC ISOLATOR
U	∅ 5	∅ 5	∅ 6/SYS	∅ 7	∅ 8	∅ 9	∅ 10	∅ 11	∅ 12	∅ 13	∅ 14	∅ 15	∅ 16	∅ 17	FS
L	5A	5B	6A/S05	6B/S06	8A	9A	10A	11A	12A	13A	14A	15A	16A	17A	DC ISOLATOR
	NOT USED	NOT USED	∅ 6/SYS	∅ 7	∅ 8	∅ 9	∅ 10	∅ 11	∅ 12	∅ 13	∅ 14	∅ 15	∅ 16	∅ 17	DC ISOLATOR
	NOT USED	NOT USED	6B/S06	∅ 7	∅ 8	∅ 9	∅ 10	∅ 11	∅ 12	∅ 13	∅ 14	∅ 15	∅ 16	∅ 17	DC ISOLATOR

EX.: 1A, 2A, ETC. = LOOP NO.'S

FS = FLASH SENSE
 ST = STOP TIME

⊗ Wired Input - Do not populate slot with detector card

INPUT FILE CONNECTION & PROGRAMMING CHART

LOOP NO.	LOOP TERMINAL	INPUT FILE POS.	PIN NO.	INPUT ASSIGNMENT NO.	DETECTOR NO.	NEMA PHASE	CALL	EXTEND	FULL TIME DELAY	STRETCH TIME	DELAY TIME
1A ¹	TB2-1,2	I1U	56	18	1	1	Y	Y			15
	-	J4U	48	10★	26	6	Y	Y			
	-	I1U	56	18★	51	1	Y	Y			
1B	TB2-5,6	I2U	39	1	2	1	Y	Y			15
	2A/S03	TB2-9,10	I3U	63	25	2/SYS	Y	Y			
	2B/S04	TB2-11,12	I3L	76	38	2/SYS	Y	Y			
4A	TB4-9,10	I6U	41	3	4	4	Y	Y			
	5A ²	TB3-1,2	J1U	55	17	5	Y	Y			15
		-	I4U	47	9★	22	2	Y	Y		
5B	TB3-5,6	J2U	40	2	6	5	Y	Y			15
	6A/S05	TB3-9,10	J3U	64	26	6/SYS	Y	Y			
	6B/S06	TB3-11,12	J3L	77	39	6/SYS	Y	Y			
8A	TB5-9,10	J6U	42	4	8	8	Y	Y			
	8B	TB5-11,12	J6L	46	8	8	Y	Y			

- Add jumper from I1-W to J4-W, on rear of input file.
- Add jumper from J1-W to I4-W, on rear of input file.

★ See vehicle detector setup programming detail for alternate phasing on sheets 4 and 5.

INPUT FILE POSITION LEGEND: J2L

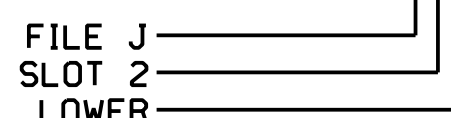

THIS ELECTRICAL DETAIL IS FOR THE SIGNAL DESIGN: 03-1122
 DESIGNED: June 2017
 SEALED: 9/10/2021
 REVISED: N/A

HNTB HNTB NORTH CAROLINA, P.C.
 343 E. Six Forks Road, Suite 200
 Raleigh, North Carolina 27609
 NC License No: C-1554
 (919) 546-8997

FYA SIGNAL WIRING DETAIL

(wire signal heads as shown)

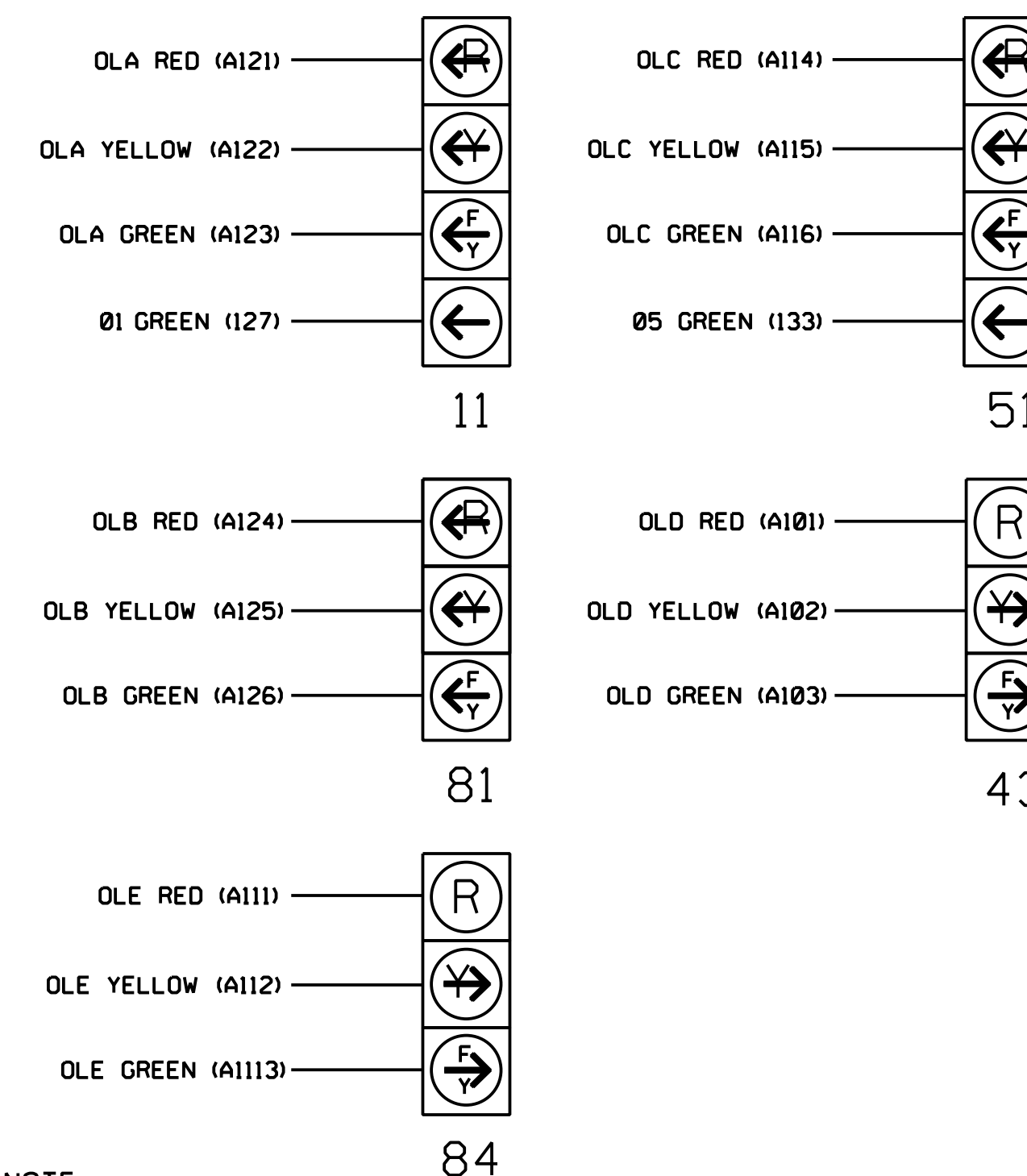

NOTE

The sequence display for signal heads 11 and 51 requires special logic programming. See sheet 2 for programming instructions.

Electrical Detail - Sheet 1 of 6
 New Installation
 Final Design

DOCUMENT NOT CONSIDERED FINAL UNLESS ALL SIGNATURES COMPLETED

ELECTRICAL AND PROGRAMMING DETAILS FOR: 	NC 906 (Midway Road) at NC 211 Northbound Ramp/ Midway Commons Driveway		SEAL
	Division 03 Brunswick Co. Southport	Prepared for: Prepared by: A.H. Thornburg Reviewed by: N.R. Simmons	
PLAN DATE: June 2017 REVIEWED BY: A.D. Klinksiek	REVIEWED BY: A.D. Klinksiek	REVIEWED BY: N.R. Simmons	DocuSigned by: Natasha R. Simmons 9/10/2021
REVISIONS INIT. DATE	INIT. DATE	INIT. DATE	SIGNATURE DATE
750 N. Greenfield Pkwy, Corner, NC 27529			SIG. INVENTORY NO. 03-1122

**LOGICAL I/O PROCESSOR PROGRAMMING DETAIL
TO PRODUCE SPECIAL FYA-PPLT SIGNAL SEQUENCE**

(program controller as shown below)

- FROM MAIN MENU PRESS '2' (PHASE CONTROL), THEN '1' (PHASE CONTROL FUNCTIONS). SCROLL TO THE BOTTOM OF THE MENU AND ENABLE ACT LOGIC COMMANDS 1, 2, 3, 4, 5, AND 6.
- FROM MAIN MENU PRESS '6' (OUTPUTS), THEN '3' (LOGICAL I/O PROCESSOR).

LOGICAL I/O COMMAND #1 (+/-COMMAND#)
IF ACTIVE PHASE #1 IS ON
AND RED CLEAR ON PHASE #1 IS ON

THEN:
SET OUTPUT ASSIGNMENT #50 ON
SET OUTPUT ASSIGNMENT #51 OFF

NOTE: LOGIC FOR PHASE 1 RED CLEAR WHEN TRANSITIONING FROM PHASE 1 TO PHASE 2 (HEAD 11).

LOGICAL I/O COMMAND #2 (+/-COMMAND#)
IF ACTIVE PHASE #1 IS ON

THEN:
SET OUTPUT ASSIGNMENT #52 OFF

NOTE: LOGIC FOR SWITCHING FLASHING YELLOW ARROW "OFF" DURING PHASE 1 (HEAD 11).

LOGICAL I/O COMMAND #3 (+/-COMMAND#)
IF YELLOW ON PHASE #1 IS ON

THEN:
SET OUTPUT ASSIGNMENT #51 ON

NOTE: LOGIC FOR YELLOW ARROW CLEARANCE FROM PHASE 1 (HEAD 11).

LOGICAL I/O COMMAND #4 (+/-COMMAND#)
IF ACTIVE PHASE #5 IS ON
AND RED CLEAR ON PHASE #5 IS ON

THEN:
SET OUTPUT ASSIGNMENT #42 ON
SET OUTPUT ASSIGNMENT #43 OFF

NOTE: LOGIC FOR PHASE 5 RED CLEAR WHEN TRANSITIONING FROM PHASE 5 TO PHASE 6 (HEAD 51).

LOGICAL I/O COMMAND #5 (+/-COMMAND#)
IF ACTIVE PHASE #5 IS ON

THEN:
SET OUTPUT ASSIGNMENT #44 OFF

NOTE: LOGIC FOR SWITCHING FLASHING YELLOW ARROW "OFF" DURING PHASE 5 (HEAD 51).

LOGICAL I/O COMMAND #6 (+/-COMMAND#)
IF YELLOW ON PHASE #5 IS ON

THEN:
SET OUTPUT ASSIGNMENT #43 ON

NOTE: LOGIC FOR YELLOW ARROW CLEARANCE FROM PHASE 5 (HEAD 51).

LOGIC I/O PROCESSOR PROGRAMMING COMPLETE

**OVERLAP PROGRAMMING DETAIL
FOR DEFAULT PHASING**

(program controller as shown below)

FROM MAIN MENU PRESS '8' (OVERLAPS), THEN '1' (VEHICLE OVERLAP SETTINGS).

PAGE 1: VEHICLE OVERLAP 'A' SETTINGS
PHASE: :12345678910111213141516
VEH OVL PARENTS: :XX
VEH OVL NOT VEH: :
VEH OVL NOT PED: :
VEH OVL GRN EXT: :
STARTUP COLOR: - RED - YELLOW - GREEN
FLASH COLORS: - RED - YELLOW X GREEN

SELECT VEHICLE OVERLAP OPTIONS: (Y/N)
FLASH YELLOW IN CONTROLLER FLASH?...Y
GREEN EXTENSION (0-255 SEC)...0.0
YELLOW CLEAR (O=PARENT,3-25.5 SEC)...0.0
RED CLEAR (O=PARENT,0.1-25.5 SEC)...0.0
OUTPUT AS PHASE # (O=NONE, 1-16)...0.0

← NOTICE GREEN FLASH

PRESS '+'

PAGE 1: VEHICLE OVERLAP 'B' SETTINGS
PHASE: :12345678910111213141516
VEH OVL PARENTS: :X
VEH OVL NOT VEH: :
VEH OVL NOT PED: :
VEH OVL GRN EXT: :
STARTUP COLOR: - RED - YELLOW - GREEN
FLASH COLORS: - RED - YELLOW X GREEN

SELECT VEHICLE OVERLAP OPTIONS: (Y/N)
FLASH YELLOW IN CONTROLLER FLASH?...N
GREEN EXTENSION (0-255 SEC)...0.0
YELLOW CLEAR (O=PARENT,3-25.5 SEC)...0.0
RED CLEAR (O=PARENT,0.1-25.5 SEC)...0.0
OUTPUT AS PHASE # (O=NONE, 1-16)...0.0

← NOTICE GREEN FLASH

PRESS '+'

PAGE 1: VEHICLE OVERLAP 'C' SETTINGS
PHASE: :12345678910111213141516
VEH OVL PARENTS: :XX
VEH OVL NOT VEH: :
VEH OVL NOT PED: :
VEH OVL GRN EXT: :
STARTUP COLOR: - RED - YELLOW - GREEN
FLASH COLORS: - RED - YELLOW X GREEN

SELECT VEHICLE OVERLAP OPTIONS: (Y/N)
FLASH YELLOW IN CONTROLLER FLASH?...Y
GREEN EXTENSION (0-255 SEC)...0.0
YELLOW CLEAR (O=PARENT,3-25.5 SEC)...0.0
RED CLEAR (O=PARENT,0.1-25.5 SEC)...0.0
OUTPUT AS PHASE # (O=NONE, 1-16)...0.0

← NOTICE GREEN FLASH

PRESS '+'

PAGE 1: VEHICLE OVERLAP 'D' SETTINGS
PHASE: :12345678910111213141516
VEH OVL PARENTS: :XX
VEH OVL NOT VEH: :
VEH OVL NOT PED: :
VEH OVL GRN EXT: :
STARTUP COLOR: - RED - YELLOW - GREEN
FLASH COLORS: - RED - YELLOW X GREEN

SELECT VEHICLE OVERLAP OPTIONS: (Y/N)
FLASH YELLOW IN CONTROLLER FLASH?...N
GREEN EXTENSION (0-255 SEC)...0.0
YELLOW CLEAR (O=PARENT,3-25.5 SEC)...0.0
RED CLEAR (O=PARENT,0.1-25.5 SEC)...0.0
OUTPUT AS PHASE # (O=NONE, 1-16)...0.0

← NOTICE GREEN FLASH

PRESS '+'

PAGE 1: VEHICLE OVERLAP 'E' SETTINGS
PHASE: :12345678910111213141516
VEH OVL PARENTS: :X X
VEH OVL NOT VEH: :
VEH OVL NOT PED: :
VEH OVL GRN EXT: :
STARTUP COLOR: - RED - YELLOW - GREEN
FLASH COLORS: - RED - YELLOW X GREEN

SELECT VEHICLE OVERLAP OPTIONS: (Y/N)
FLASH YELLOW IN CONTROLLER FLASH?...N
GREEN EXTENSION (0-255 SEC)...0.0
YELLOW CLEAR (O=PARENT,3-25.5 SEC)...0.0
RED CLEAR (O=PARENT,0.1-25.5 SEC)...0.0
OUTPUT AS PHASE # (O=NONE, 1-16)...0.0

← NOTICE GREEN FLASH

OVERLAP PROGRAMMING COMPLETE

**OVERLAP PROGRAMMING DETAIL
FOR ALTERNATE PHASING**

(program controller as shown below)

FROM MAIN MENU PRESS '8' (OVERLAPS), THEN '1' (VEHICLE OVERLAP SETTINGS). PRESS 'NEXT' TO ADVANCE TO PAGE 2.

NOTICE PAGE 2 → PAGE 2: VEHICLE OVERLAP 'A' SETTINGS
PHASE: :12345678910111213141516
VEH OVL PARENTS: :X
VEH OVL NOT VEH: :
VEH OVL NOT PED: :
VEH OVL GRN EXT: :
STARTUP COLOR: - RED - YELLOW - GREEN
FLASH COLORS: - RED - YELLOW - GREEN

SELECT VEHICLE OVERLAP OPTIONS: (Y/N)
FLASH YELLOW IN CONTROLLER FLASH?...Y
GREEN EXTENSION (0-255 SEC)...0.0
YELLOW CLEAR (O=PARENT,3-25.5 SEC)...0.0
RED CLEAR (O=PARENT,0.1-25.5 SEC)...0.0
OUTPUT AS PHASE # (O=NONE, 1-16)...0.0

PRESS '+'

NOTICE PAGE 2 → PAGE 2: VEHICLE OVERLAP 'B' SETTINGS
PHASE: :12345678910111213141516
VEH OVL PARENTS: :X
VEH OVL NOT VEH: :
VEH OVL NOT PED: :
VEH OVL GRN EXT: :
STARTUP COLOR: - RED - YELLOW - GREEN
FLASH COLORS: - RED - YELLOW X GREEN

SELECT VEHICLE OVERLAP OPTIONS: (Y/N)
FLASH YELLOW IN CONTROLLER FLASH?...N
GREEN EXTENSION (0-255 SEC)...0.0
YELLOW CLEAR (O=PARENT,3-25.5 SEC)...0.0
RED CLEAR (O=PARENT,0.1-25.5 SEC)...0.0
OUTPUT AS PHASE # (O=NONE, 1-16)...0.0

← NOTICE GREEN FLASH

PRESS '+'

NOTICE PAGE 2 → PAGE 2: VEHICLE OVERLAP 'C' SETTINGS
PHASE: :12345678910111213141516
VEH OVL PARENTS: :X
VEH OVL NOT VEH: :
VEH OVL NOT PED: :
VEH OVL GRN EXT: :
STARTUP COLOR: - RED - YELLOW - GREEN
FLASH COLORS: - RED - YELLOW - GREEN

SELECT VEHICLE OVERLAP OPTIONS: (Y/N)
FLASH YELLOW IN CONTROLLER FLASH?...Y
GREEN EXTENSION (0-255 SEC)...0.0
YELLOW CLEAR (O=PARENT,3-25.5 SEC)...0.0
RED CLEAR (O=PARENT,0.1-25.5 SEC)...0.0
OUTPUT AS PHASE # (O=NONE, 1-16)...0.0

PRESS '+'

NOTICE PAGE 2 → PAGE 2: VEHICLE OVERLAP 'D' SETTINGS
PHASE: :12345678910111213141516
VEH OVL PARENTS: :XX
VEH OVL NOT VEH: :
VEH OVL NOT PED: :
VEH OVL GRN EXT: :
STARTUP COLOR: - RED - YELLOW - GREEN
FLASH COLORS: - RED - YELLOW X GREEN

SELECT VEHICLE OVERLAP OPTIONS: (Y/N)
FLASH YELLOW IN CONTROLLER FLASH?...N
GREEN EXTENSION (0-255 SEC)...0.0
YELLOW CLEAR (O=PARENT,3-25.5 SEC)...0.0
RED CLEAR (O=PARENT,0.1-25.5 SEC)...0.0
OUTPUT AS PHASE # (O=NONE, 1-16)...0.0

← NOTICE GREEN FLASH

PRESS '+'

NOTICE PAGE 2 → PAGE 2: VEHICLE OVERLAP 'E' SETTINGS
PHASE: :12345678910111213141516
VEH OVL PARENTS: :X X
VEH OVL NOT VEH: :
VEH OVL NOT PED: :
VEH OVL GRN EXT: :
STARTUP COLOR: - RED - YELLOW - GREEN
FLASH COLORS: - RED - YELLOW X GREEN

SELECT VEHICLE OVERLAP OPTIONS: (Y/N)
FLASH YELLOW IN CONTROLLER FLASH?...N
GREEN EXTENSION (0-255 SEC)...0.0
YELLOW CLEAR (O=PARENT,3-25.5 SEC)...0.0
RED CLEAR (O=PARENT,0.1-25.5 SEC)...0.0
OUTPUT AS PHASE # (O=NONE, 1-16)...0.0

← NOTICE GREEN FLASH

OVERLAP PROGRAMMING COMPLETE

OUTPUT REFERENCE SCHEDULE

USE TO INTERPRET LOGIC PROCESSOR

- OUTPUT 42 = Overlap C Red
- OUTPUT 43 = Overlap C Yellow
- OUTPUT 44 = Overlap C Green
- OUTPUT 50 = Overlap A Red
- OUTPUT 51 = Overlap A Yellow
- OUTPUT 52 = Overlap A Green

THIS ELECTRICAL DETAIL IS FOR THE SIGNAL DESIGN: 03-1122
DESIGNED: June 2017
SEALED: 9/10/2021
REVISED: N/A



HNTB NORTH CAROLINA, P.C.
343 E. Six Forks Road, Suite 200
Raleigh, North Carolina 27609
NC License No: C-1554
(919) 546-8997

Electrical Detail - Sheet 2 of 6
New Installation
Final Design

**DOCUMENT NOT CONSIDERED FINAL
UNLESS ALL SIGNATURES COMPLETED**

ELECTRICAL AND PROGRAMMING DETAILS FOR:

Prepared for:

750 N. Greenfield Pkwy, Corner, NC 27529

NC 906 (Midway Road) at
NC 211 Northbound Ramp/
Midway Commons Driveway

Division 03 Brunswick Co. Southport

PLAN DATE: June 2017 REVIEWED BY: A.D. Klinksiek

PREPARED BY: A.H. Thornburg REVIEWED BY: N.R. Simmons

REVISIONS	INIT.	DATE

SEAL

DocuSigned by:
Natasha Simmons
9/10/2021

SIGNATURE DATE

SIG. INVENTORY NO. 03-1122

INPUT PAGE 2 ASSIGNMENT PROGRAMMING DETAIL FOR ALTERNATE PHASING - LOOP 1A

(program controller as shown below)

- NOTES: 1. THIS PROGRAMMING APPLIES FOR INPUT PAGE 2 ONLY. INPUT PAGE 1 WILL USE STANDARD DEFAULT SETTINGS. THIS PROGRAMMING IS NECESSARY FOR PROPER DETECTOR OPERATION DURING ALTERNATE PHASING OPERATION.
2. THE FIRST TASK THIS PROGRAMMING ACCOMPLISHES IS THE DISABLING OF INPUT #10 (DETECTOR 26) SO THAT A VEHICLE CALL WILL NOT BE PLACED TO PHASE 6 DURING ALTERNATE PHASING OPERATION. THE SECOND TASK THIS PROGRAMMING ACCOMPLISHES IS THAT IT REASSIGNS DETECTOR 51 TO INPUT #18 SO THAT THE DELAY ON LOOP 1A CAN BE REDUCED FROM 15 SECONDS TO 0 SECONDS.

FROM MAIN MENU PRESS '5' (INPUTS). THEN PRESS 'NEXT' TO GET TO INPUT PAGE '2'. PRESS THE '+' KEY UNTIL INPUT 10 IS REACHED.

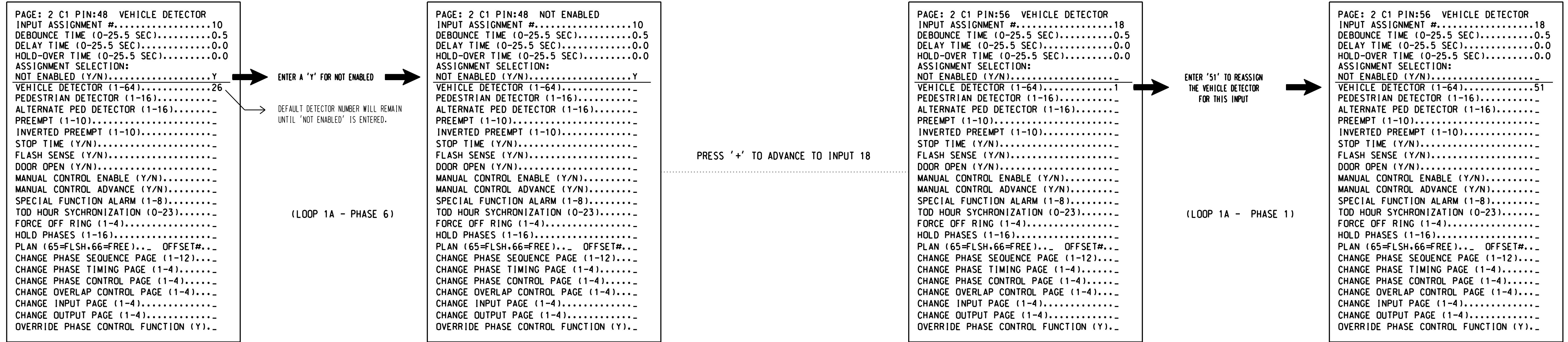

PROGRAMMING COMPLETE

SPECIAL DETECTOR PROGRAMMING DETAIL - LOOP 1A (ALT.)

(program controller as shown below)

FROM MAIN MENU PRESS '7' (DETECTORS). THEN PRESS '1' FOR VEHICLE DETECTORS. PRESS THE '-' KEY TO GET TO VEHICLE DETECTOR #51.

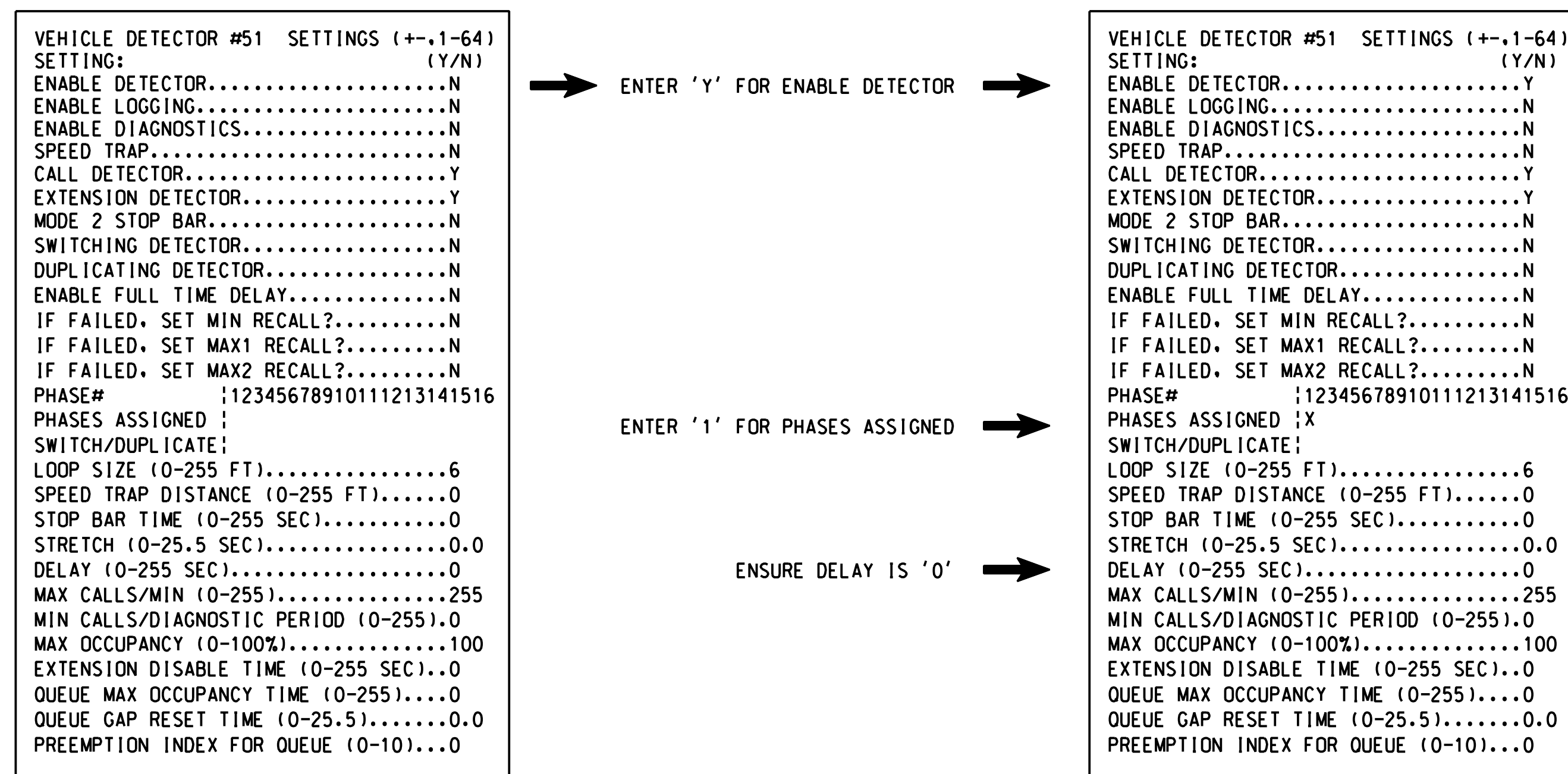

NOTE: DETECTOR IS PROGRAMMED PER THE INPUT FILE CONNECTION AND PROGRAMMING CHART SHOWN ON SHEET 1.

THIS ELECTRICAL DETAIL IS FOR THE SIGNAL DESIGN: 03-1122
 DESIGNED: June 2017
 SEALED: 9/10/2021
 REVISED: N/A

Electrical Detail - Sheet 3 of 6
 New Installation
 Final Design

**DOCUMENT NOT CONSIDERED FINAL
 UNLESS ALL SIGNATURES COMPLETED**

	Prepared for: NC 906 (Midway Road) at NC 211 Northbound Ramp/ Midway Commons Driveway		SEAL
	Division 03 Brunswick Co. Southport		
PLAN DATE: June 2017	REVIEWED BY: A.D. Klinskyk		
PREPARED BY: A.H. Thornburg	REVIEWED BY: N.R. Simmons		
REVISIONS	INIT.	DATE	SIGNATURE
			DATE
			SIG. INVENTORY NO. 03-1122

INPUT PAGE 2 ASSIGNMENT PROGRAMMING DETAIL FOR ALTERNATE PHASING - LOOP 5A

(program controller as shown below)

- NOTES: 1. THIS PROGRAMMING APPLIES FOR INPUT PAGE 2 ONLY. INPUT PAGE 1 WILL USE STANDARD DEFAULT SETTINGS. THIS PROGRAMMING IS NECESSARY FOR PROPER DETECTOR OPERATION DURING ALTERNATE PHASING OPERATION. 2. THE FIRST TASK THIS PROGRAMMING ACCOMPLISHES IS THE DISABLING OF INPUT #9 (DETECTOR 22) SO THAT A VEHICLE CALL WILL NOT BE PLACED TO PHASE 2 DURING ALTERNATE PHASING OPERATION. THE SECOND TASK THIS PROGRAMMING ACCOMPLISHES IS THAT IT REASSIGNS DETECTOR 55 TO INPUT #17 SO THAT THE DELAY ON LOOP 5A CAN BE REDUCED FROM 15 SECONDS TO 0 SECONDS.

FROM MAIN MENU PRESS '5' (INPUTS), THEN PRESS 'NEXT' TO GET TO INPUT PAGE '2'. PRESS THE '+' KEY UNTIL INPUT 9 IS REACHED.

PAGE: 2 C1 PIN:47 VEHICLE DETECTOR INPUT ASSIGNMENT #.....9 DEBOUNCE TIME (0-25.5 SEC).....0.5 DELAY TIME (0-25.5 SEC).....0.0 HOLD-OVER TIME (0-25.5 SEC).....0.0 ASSIGNMENT SELECTION: NOT ENABLED (Y/N).....Y

ENTER A 'Y' FOR NOT ENABLED

(LOOP 5A - PHASE 2)

PAGE: 2 C1 PIN:47 NOT ENABLED INPUT ASSIGNMENT #.....9 DEBOUNCE TIME (0-25.5 SEC).....0.5 DELAY TIME (0-25.5 SEC).....0.0 HOLD-OVER TIME (0-25.5 SEC).....0.0 ASSIGNMENT SELECTION: NOT ENABLED (Y/N).....Y

PRESS '+' TO ADVANCE TO INPUT 17

PAGE: 2 C1 PIN:55 VEHICLE DETECTOR INPUT ASSIGNMENT #.....17 DEBOUNCE TIME (0-25.5 SEC).....0.5 DELAY TIME (0-25.5 SEC).....0.0 HOLD-OVER TIME (0-25.5 SEC).....0.0 ASSIGNMENT SELECTION: NOT ENABLED (Y/N).....Y

ENTER '55' TO REASSIGN THE VEHICLE DETECTOR FOR THIS INPUT

(LOOP 5A - PHASE 5)

PAGE: 2 C1 PIN:55 VEHICLE DETECTOR INPUT ASSIGNMENT #.....17 DEBOUNCE TIME (0-25.5 SEC).....0.5 DELAY TIME (0-25.5 SEC).....0.0 HOLD-OVER TIME (0-25.5 SEC).....0.0 ASSIGNMENT SELECTION: NOT ENABLED (Y/N).....Y

PROGRAMMING COMPLETE

SPECIAL DETECTOR PROGRAMMING DETAIL - LOOP 5A (ALT.)

(program controller as shown below)

FROM MAIN MENU PRESS '7' (DETECTORS), THEN PRESS '1' FOR VEHICLE DETECTORS. PRESS THE '-' KEY TO GET TO VEHICLE DETECTOR #55.

VEHICLE DETECTOR #55 SETTINGS (+,-,1-64) SETTING: (Y/N) ENABLE DETECTOR.....N ENABLE LOGGING.....N ENABLE DIAGNOSTICS.....N SPEED TRAP.....N CALL DETECTOR.....Y EXTENSION DETECTOR.....Y MODE 2 STOP BAR.....N SWITCHING DETECTOR.....N DUPLICATING DETECTOR.....N ENABLE FULL TIME DELAY.....N IF FAILED, SET MIN RECALL?.....N IF FAILED, SET MAX1 RECALL?.....N IF FAILED, SET MAX2 RECALL?.....N PHASE# :12345678910111213141516 PHASES ASSIGNED : SWITCH/DUPLICATE: LOOP SIZE (0-255 FT).....6 SPEED TRAP DISTANCE (0-255 FT).....0 STOP BAR TIME (0-255 SEC).....0 STRETCH (0-25.5 SEC).....0.0 DELAY (0-255 SEC).....0 MAX CALLS/MIN (0-255).....255 MIN CALLS/DIAGNOSTIC PERIOD (0-255).....0 MAX OCCUPANCY (0-100%).....100 EXTENSION DISABLE TIME (0-255 SEC).....0 QUEUE MAX OCCUPANCY TIME (0-255).....0 QUEUE GAP RESET TIME (0-25.5).....0.0 PREEMPTION INDEX FOR QUEUE (0-10).....0

ENTER 'Y' FOR ENABLE DETECTOR

ENTER '5' FOR PHASES ASSIGNED

ENSURE DELAY IS '0'

VEHICLE DETECTOR #55 SETTINGS (+,-,1-64) SETTING: (Y/N) ENABLE DETECTOR.....Y ENABLE LOGGING.....N ENABLE DIAGNOSTICS.....N SPEED TRAP.....N CALL DETECTOR.....Y EXTENSION DETECTOR.....Y MODE 2 STOP BAR.....N SWITCHING DETECTOR.....N DUPLICATING DETECTOR.....N ENABLE FULL TIME DELAY.....N IF FAILED, SET MIN RECALL?.....N IF FAILED, SET MAX1 RECALL?.....N IF FAILED, SET MAX2 RECALL?.....N PHASE# :12345678910111213141516 PHASES ASSIGNED : X SWITCH/DUPLICATE: LOOP SIZE (0-255 FT).....6 SPEED TRAP DISTANCE (0-255 FT).....0 STOP BAR TIME (0-255 SEC).....0 STRETCH (0-25.5 SEC).....0.0 DELAY (0-255 SEC).....0 MAX CALLS/MIN (0-255).....255 MIN CALLS/DIAGNOSTIC PERIOD (0-255).....0 MAX OCCUPANCY (0-100%).....100 EXTENSION DISABLE TIME (0-255 SEC).....0 QUEUE MAX OCCUPANCY TIME (0-255).....0 QUEUE GAP RESET TIME (0-25.5).....0.0 PREEMPTION INDEX FOR QUEUE (0-10).....0

DETECTOR PROGRAMMING COMPLETE

NOTE: DETECTOR IS PROGRAMMED PER THE INPUT FILE CONNECTION AND PROGRAMMING CHART SHOWN ON SHEET 1.

THIS ELECTRICAL DETAIL IS FOR THE SIGNAL DESIGN: 03-1122 DESIGNED: June 2017 SEALED: 9/10/2021 REVISED: N/A

Electrical Detail - Sheet 4 of 6 New Installation Final Design

DOCUMENT NOT CONSIDERED FINAL UNLESS ALL SIGNATURES COMPLETED

HNTB HNTB NORTH CAROLINA, P.C. 343 E. Six Forks Road, Suite 200 Raleigh, North Carolina 27609 NC License No: C-1564 (919) 546-8997

Professional Engineer Seal for Natasha R. Simmons, State of North Carolina, License No. 031464. Includes project details for NC 906 (Midway Road) at NC 211 Northbound Ramp/Midway Commons Driveway, prepared by A.H. Thornburg and reviewed by N.R. Simmons on 9/10/2021.

ALTERNATE PHASING ACTIVATION DETAIL

TO RUN ALT. PHASING DURING COORDINATION - SELECT ALL PAGE CHANGES (AS SHOWN BELOW) WITHIN COORDINATION PLAN PROGRAMMING.

TO RUN ALT. PHASING DURING FREE RUN - PROGRAM PAGE CHANGES (SHOWN BELOW) IN SEPARATE TIME OF DAY EVENTS. IF PAGE 1 IS USED, NO EVENT PROGRAMMING IS NECESSARY FOR THAT PARTICULAR PAGE.

<u>PHASING</u>	<u>INPUTS PAGE</u>	<u>OVERLAPS PAGE</u>
ACTIVE PAGES REQUIRED TO RUN <u>DEFAULT PHASING</u>	1	1
ACTIVE PAGES REQUIRED TO RUN <u>ALTERNATE PHASING</u>	2	2

NOTE: PAGES NOT SHOWN (i.e. sequence, phase control, etc.) SHOULD REMAIN AS '1', OR AS DEFINED BY TIMING ENGINEER.

IMPORTANT: IF ALT. PHASING IS USED DURING FREE RUN AND COORDINATION, DO NOT OPERATE TIME OF DAY PAGE CHANGE EVENTS CONCURRENTLY WITH COORDINATION PLAN EVENTS IN THE EVENT SCHEDULER. (EX. FREE RUN PAGE CHANGE EVENT SHOULD END BEFORE COORDINATION PLAN EVENT STARTS AND VICE-VERSA).

ALTERNATE PHASING PAGE CHANGE SUMMARY

THE FOLLOWING IS A SUMMARY OF WHAT TAKES PLACE WHEN THESE OVERLAP/INPUT PAGE CHANGES ACTIVATE TO CALL THE "ALTERNATE PHASING":

OVERLAPS PAGE 2: Modifies overlap parent phases for heads 11 and 51 to run protected turns only.

INPUTS PAGE 2: Disables phase 6 call on loop 1A and reduces delay time for phase 1 call on loop 1A to 0 seconds.

Disables phase 2 call on loop 5A and reduces delay time for phase 5 call on loop 5A to 0 seconds.

FLASHER CIRCUIT MODIFICATION DETAIL

IN ORDER TO INSURE THAT SIGNALS FLASH CONCURRENTLY ON THE SAME APPROACH, MAKE THE FOLLOWING FLASHER CIRCUIT CHANGES:

1. ON REAR OF PDA - REMOVE WIRE FROM TERM. T2-4 AND TERMINATE ON T2-2.
2. ON REAR OF PDA - REMOVE WIRE FROM TERM. T2-5 AND TERMINATE ON T2-3.
3. REMOVE FLASHER UNIT 2.

THE CHANGES LISTED ABOVE TIES ALL PHASES AND OVERLAPS TO FLASHER UNIT 1.

THIS ELECTRICAL DETAIL IS FOR THE SIGNAL DESIGN: 03-1122
DESIGNED: June 2017
SEALED: 9/10/2021
REVISED: N/A

Electrical Detail - Sheet 5 of 6
New Installation
Final Design

**DOCUMENT NOT CONSIDERED FINAL
UNLESS ALL SIGNATURES COMPLETED**

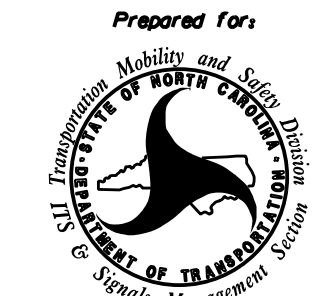
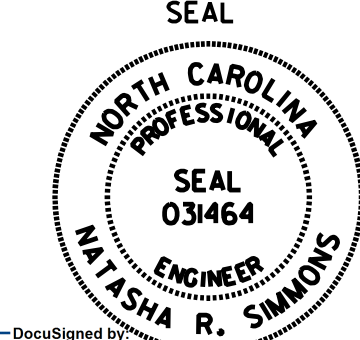
<p style="font-size: small;">ELECTRICAL AND PROGRAMMING DETAILS FOR:</p> <p style="font-size: x-small;">Prepared for:  750 N. Greenfield Pkwy, Corner, NC 27529</p>	<p style="text-align: center;">NC 906 (Midway Road) at NC 211 Northbound Ramp/ Midway Commons Driveway</p> <p style="font-size: x-small;">Division 03 Brunswick Co. Southport</p> <p style="font-size: x-small;">PLAN DATE: June 2017 REVIEWED BY: A.D. Klinksiek</p> <p style="font-size: x-small;">PREPARED BY: A.H. Thornburg REVIEWED BY: N.R. Simmons</p> <table border="1" style="width: 100%; border-collapse: collapse;"> <thead> <tr> <th style="font-size: x-small;">REVISIONS</th> <th style="font-size: x-small;">INIT.</th> <th style="font-size: x-small;">DATE</th> </tr> </thead> <tbody> <tr> <td> </td> <td> </td> <td> </td> </tr> </tbody> </table>	REVISIONS	INIT.	DATE				<p style="text-align: center;">SEAL</p> <p style="text-align: center;"></p> <p style="font-size: x-small;">DocuSigned by: <i>Natasha Simmons</i> 9/10/2021</p> <p style="font-size: x-small;">SIGNATURE DATE</p> <p style="font-size: x-small;">SIG. INVENTORY NO. 03-1122</p>
REVISIONS	INIT.	DATE						

Design Loading for METAL POLE NO. 1

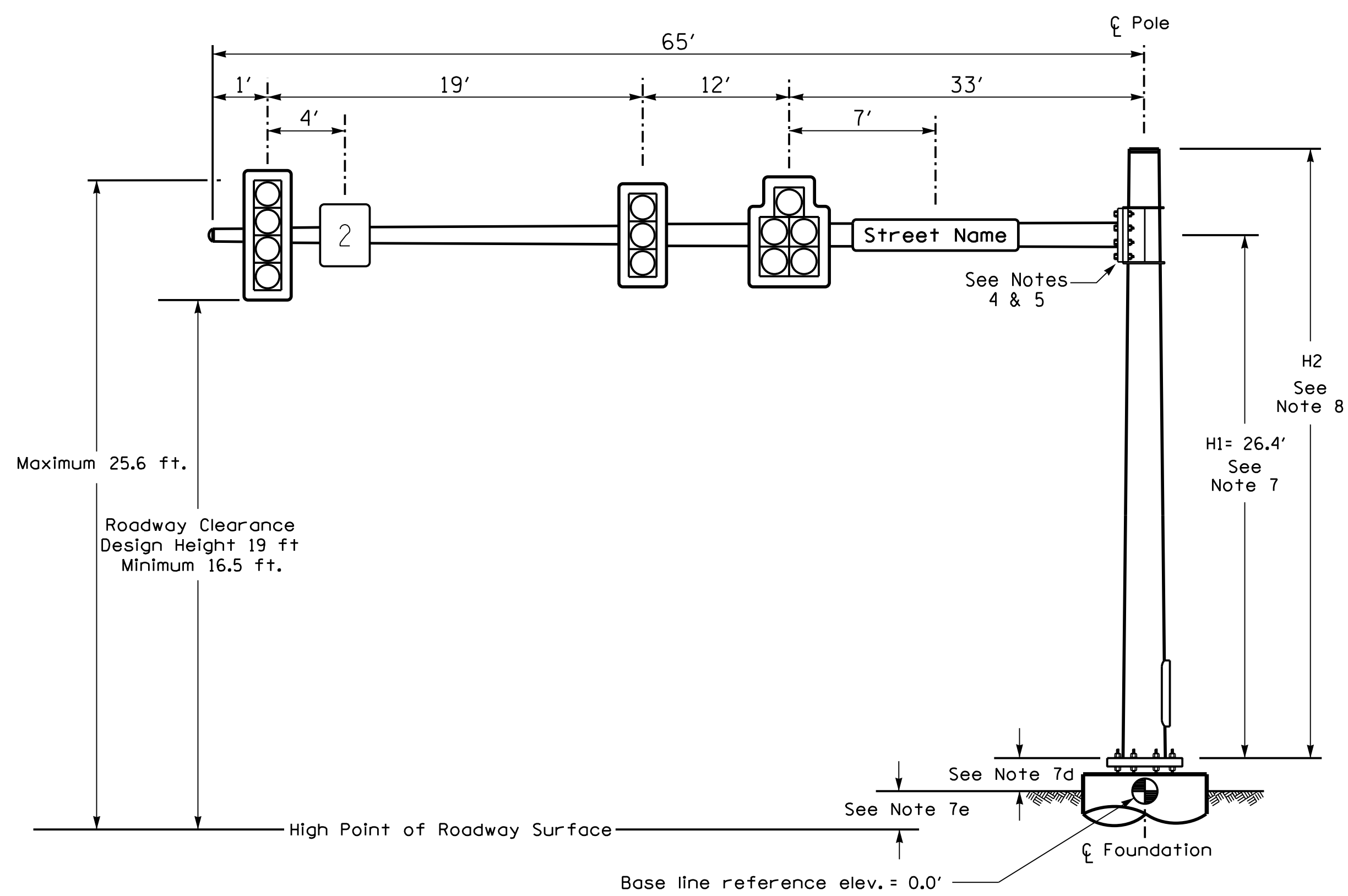

Elevation View

Design Loading for METAL POLE NO. 2

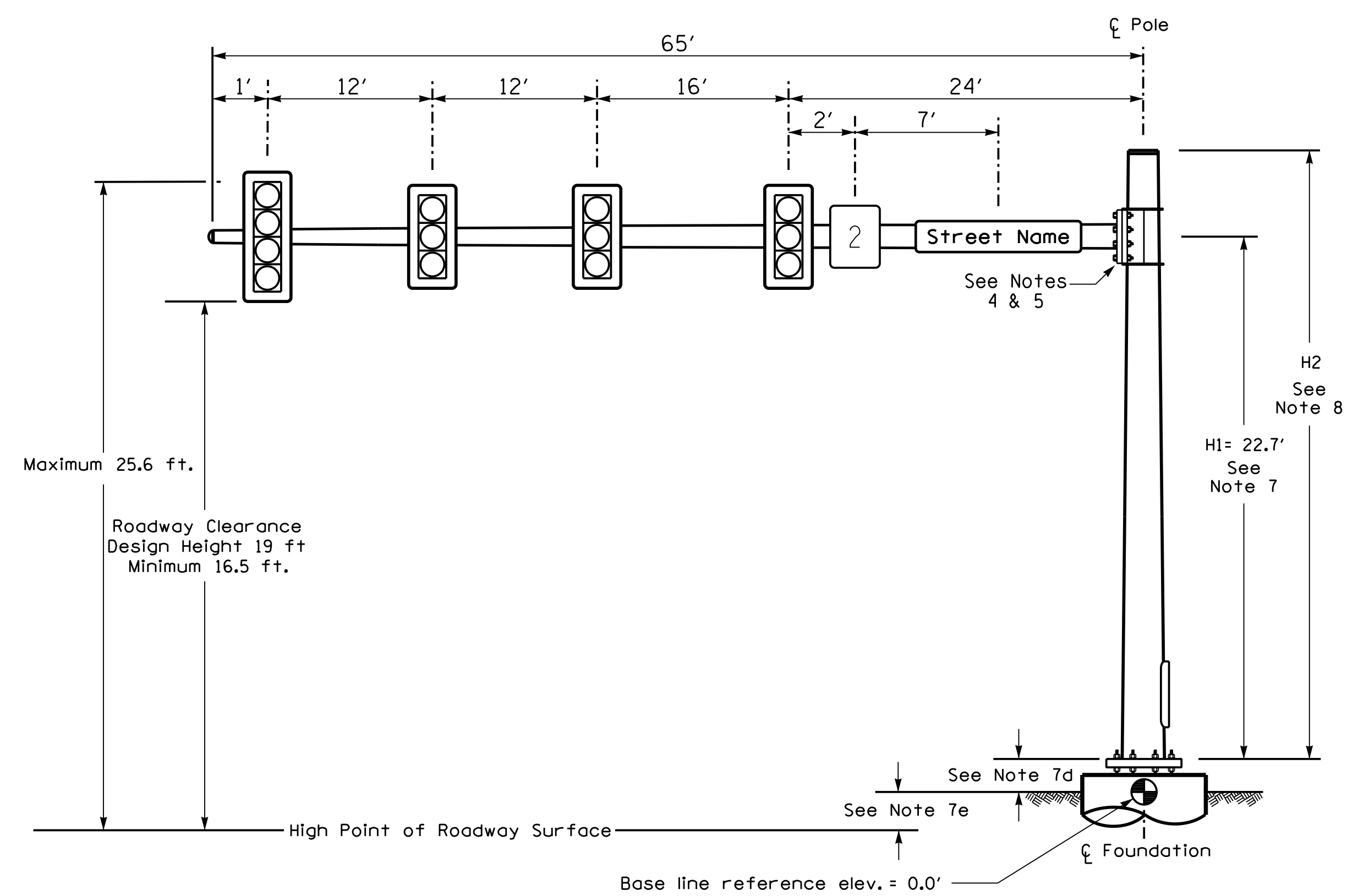

Elevation View

SPECIAL NOTE

The contractor is responsible for verifying that the mast arm attachment height (H1) will provide the "Design Height" clearance from the roadway before submitting final shop drawings for approval. Verify elevation data below which was obtained by field measurement or from available project survey data.

Elevation Data for Mast Arm Attachment (H1)

Elevation Differences for:	Pole 1	Pole 2
Baseline reference point at ϕ Foundation @ ground level	0.0 ft.	0.0 ft.
Elevation difference at High point of roadway surface	+5.39 ft.	+1.73 ft.
Elevation difference at Edge of travelway or face of curb	+4.73 ft.	+0.51 ft.

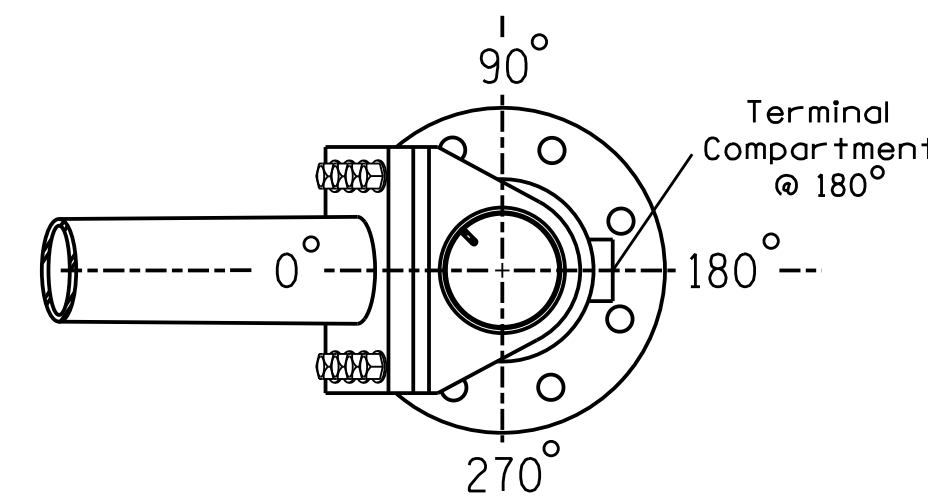

POLE RADIAL ORIENTATION

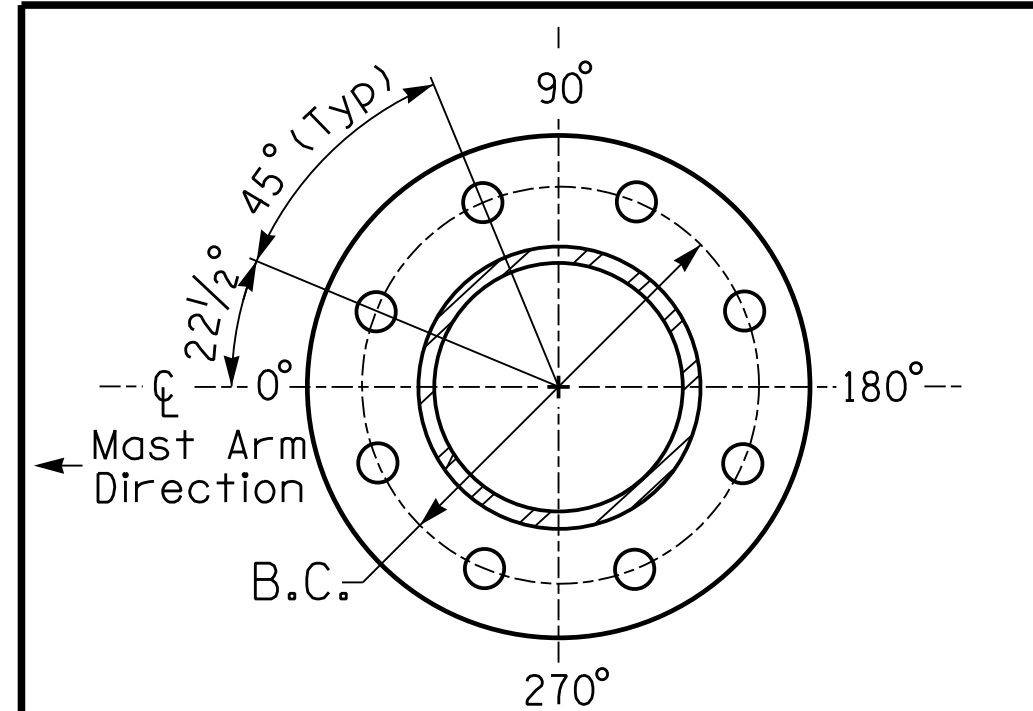

8 BOLT BASE PLATE DETAIL

See Note 6

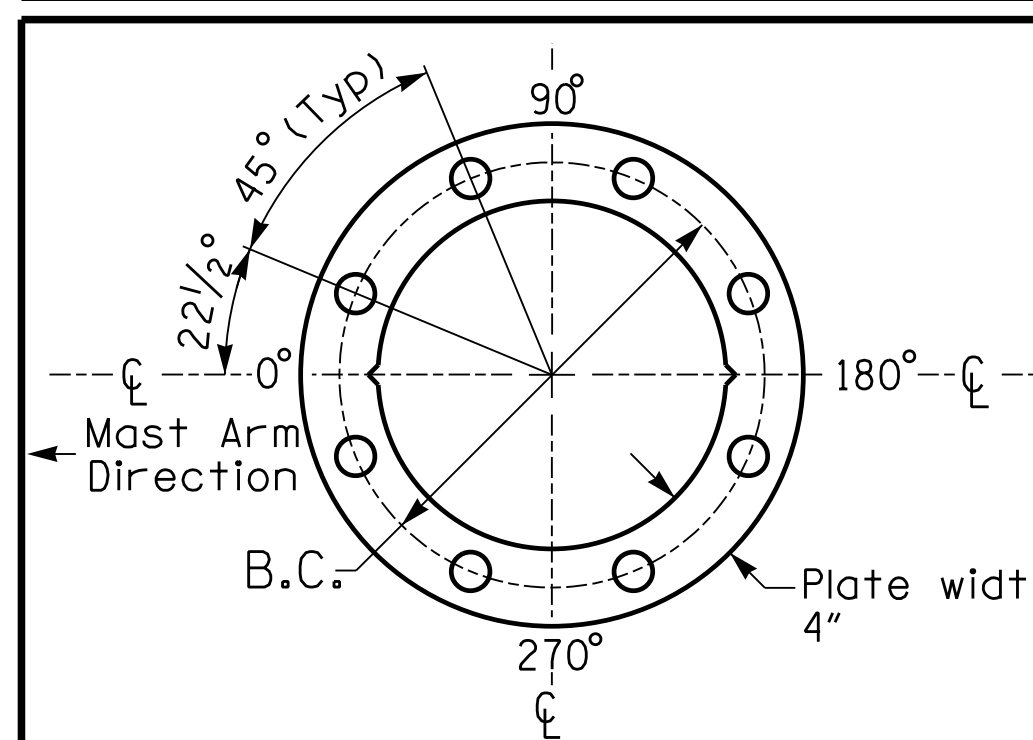

BASE PLATE TEMPLATE & ANCHOR BOLT LOCK PLATE DETAIL
For 8 Bolt Base Plate

MAST ARM LOADING SCHEDULE

LOADING SYMBOL	DESCRIPTION	AREA	SIZE	WEIGHT
	RIGID MOUNTED SIGNAL HEAD 12"-3 SECTION-WITH BACKPLATE	9.3 S.F.	25.5" W X 52.5" L	60 LBS
	RIGID MOUNTED SIGNAL HEAD 12"-4 SECTION-WITH BACKPLATE	11.5 S.F.	25.5" W X 66.0" L	74 LBS
	RIGID MOUNTED SIGNAL HEAD 12"-5 SECTION-WITH BACKPLATE	16.3 S.F.	42.0" W X 56.0" L	103 LBS
	SIGN RIGID MOUNTED	7.5 S.F.	30.0" W X 36.0" L	14 LBS
	STREET NAME SIGN RIGID MOUNTED	16.0 S.F.	24.0" W X 96.0" L	36 LBS

NOTES

DESIGN REFERENCE MATERIAL

- Design the traffic signal structure and foundation in accordance with:
 - The 6th Edition 2013 AASHTO "Standard Specifications for Structural Supports for Highway Signs, Luminaires, and Traffic Signals, including all of the latest interim revisions.
 - The 2018 NCDOT "Standard Specifications for Roads and Structures." The latest addenda to the specifications can be found in the traffic signal project special provisions.
 - The 2018 NCDOT Roadway Standard Drawings.
 - The traffic signal project plans and special provisions.
 - The NCDOT "Metal Pole Standards" located at the following NCDOT website: <https://connect.ncdot.gov/resources/safety/Pages/ITS-Design-Resources.aspx>

DESIGN REQUIREMENTS

- Design the traffic signal structure using the loading conditions shown in the elevation views. These are anticipated worst case "design loads" and may not represent the actual loads that will be applied at the time of the installation. The contractor should refer to the traffic signal plans for the actual loads that will be applied at the time of the installation.
- Design all signal supports using stress ratios that do not exceed 0.9.
- The camber design for the mast arm deflection should provide an appearance of a low pitched arch where the tip or the free end of the mast arm does not deflect below horizontal when fully loaded.
- A clamp-type bolted mast arm-to-pole connection may be used instead of the welded ring stiffened box connection shown as long as the connection meets all of the design requirements.
- Design base plate with 8 anchor bolt holes. Provide 2 inch x 60 inch anchor bolts.
- The mast arm attachment height (H1) shown is based on the following design assumptions:
 - Mast arm slope and deflection are not considered in determining the arm attachment height as they are assumed to offset each other.
 - Signal heads are rigidly mounted and vertically centered on the mast arm.
 - The roadway clearance height for design is as shown in the elevation views.
 - The top of the pole base plate is 0.75 feet above the ground elevation.
 - Refer to the Elevation Data Chart for the elevation differences between the proposed foundation ground level and the high point of the roadway.
- The pole manufacturer will determine the total height (H2) of each pole using the greater of the following:
 - Mast arm attachment height (H1) plus 2 feet, or
 - H1 plus 1/2 of the total height of the mast arm attachment assembly plus 1 foot.
- If pole location adjustments are required, the contractor must gain approval from the Engineer as this may affect the mast arm lengths and arm attachment heights. The contractor may contact the Signal Design Section Senior Structural Engineer for assistance at (919) 814-5000.
- The contractor is responsible for verifying that the mast arm length shown will allow proper positioning of the signal heads over the roadway.
- The contractor is responsible for providing soil penetration testing data (SPT) to the pole manufacturer so site specific foundations can be designed.

NCDOT Wind Zone 2 (130 mph)

DOCUMENT NOT CONSIDERED FINAL UNLESS ALL SIGNATURES COMPLETED

	NC 906 (Midway Road) at NC 211 Northbound Ramp/ Midway Commons Driveway		
	Division 03 Brunswick Co. Southport	PLAN DATE: June 2017 REVIEWED BY: A.D. Klinskyk PREPARED BY: A.H. Thornburg REVIEWED BY: N.R. Simmons	
SCALE: 0 N/A N/A	REVISIONS:	INIT. DATE:	SIGNATURE: N. R. Simmons DATE: 9/10/2021 SIG. INVENTORY NO. 03-1122

Design Loading for METAL POLE NO. 3

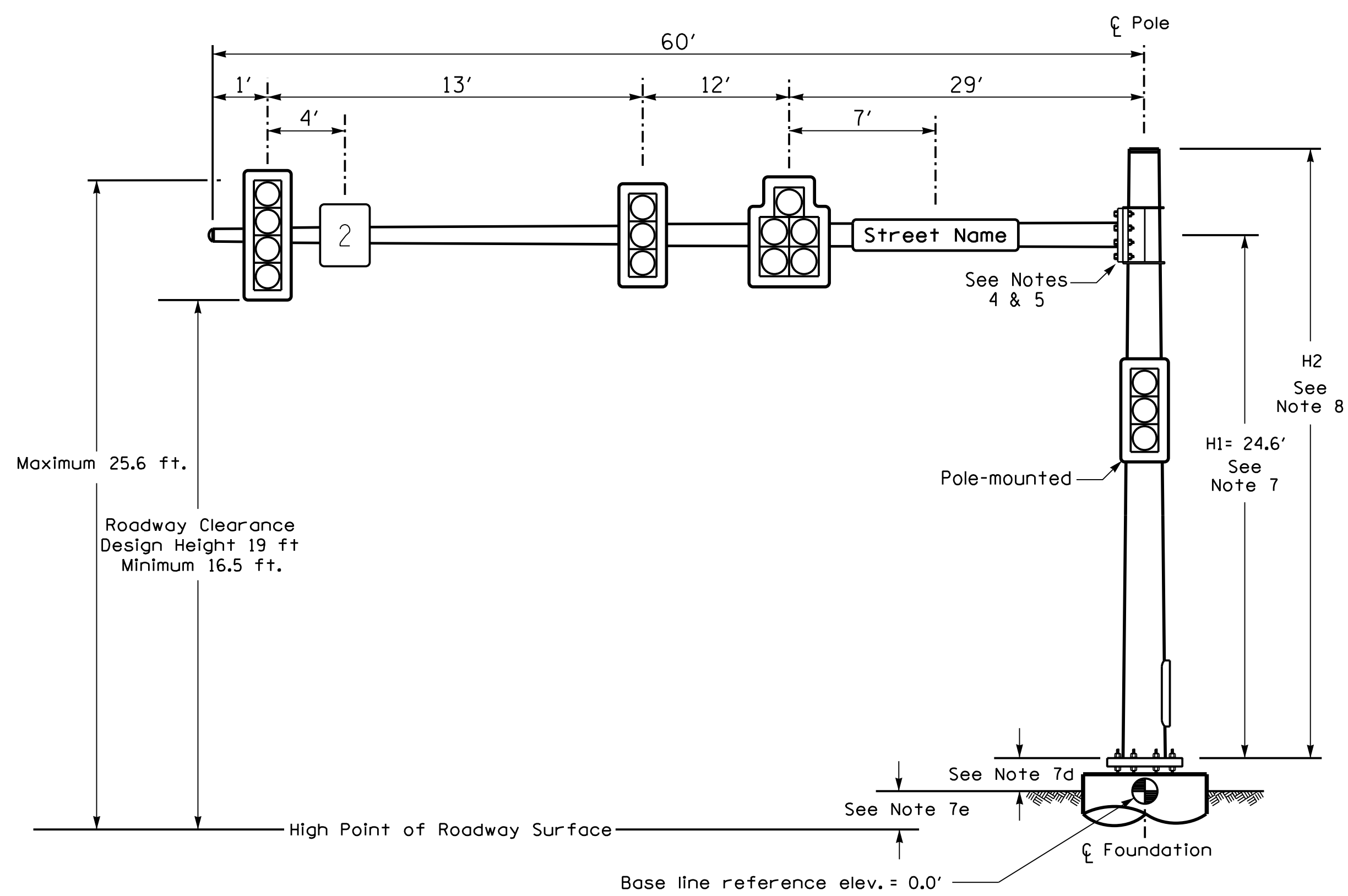

Elevation View

Design Loading for METAL POLE NO. 4

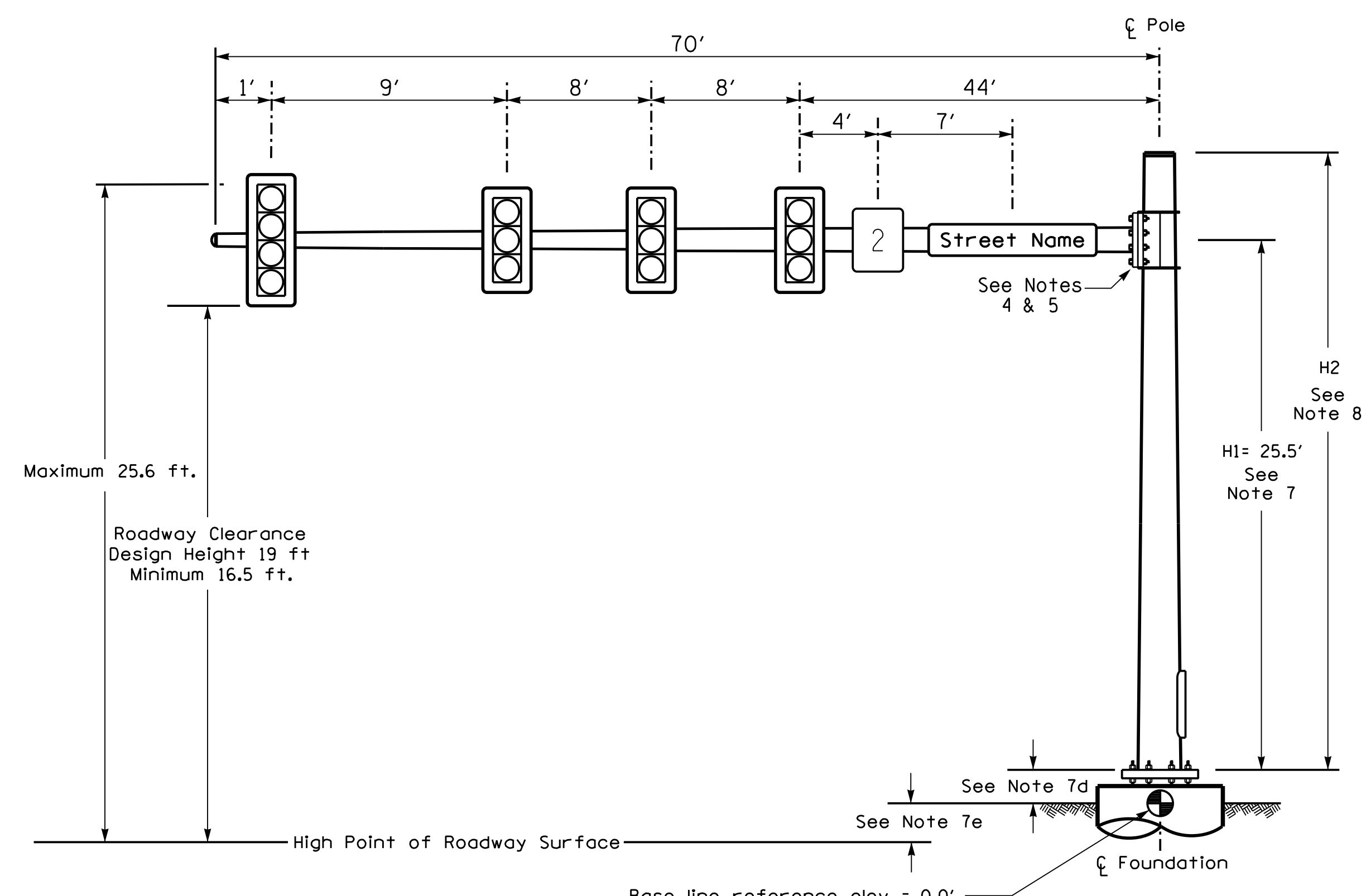

Elevation View

SPECIAL NOTE

The contractor is responsible for verifying that the mast arm attachment height (H1) will provide the "Design Height" clearance from the roadway before submitting final shop drawings for approval. Verify elevation data below which was obtained by field measurement or from available project survey data.

Elevation Data for Mast Arm Attachment (H1)

Elevation Differences for:	Pole 3	Pole 4
Baseline reference point at ϕ Foundation @ ground level	0.0 ft.	0.0 ft.
Elevation difference at High point of roadway surface	+3.58 ft.	+4.49 ft.
Elevation difference at Edge of travelway or face of curb	+2.88 ft.	+4.46 ft.

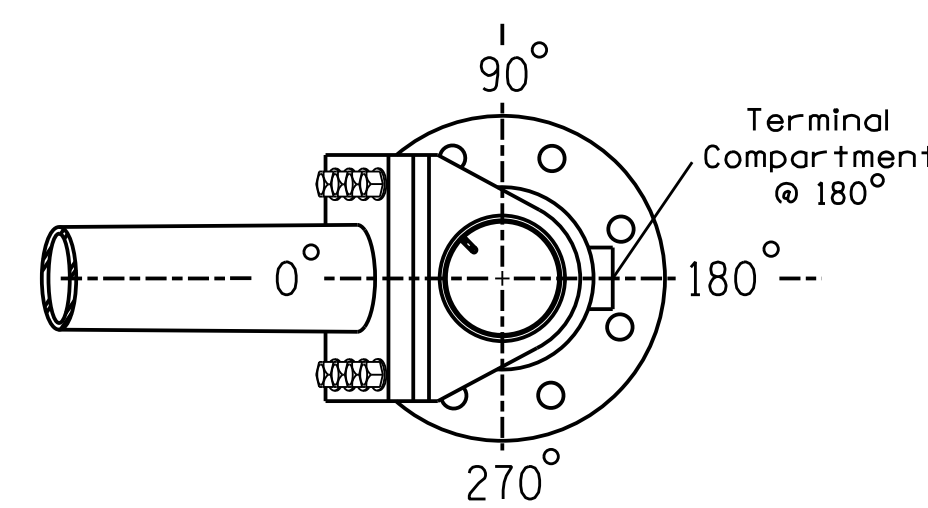

POLE RADIAL ORIENTATION

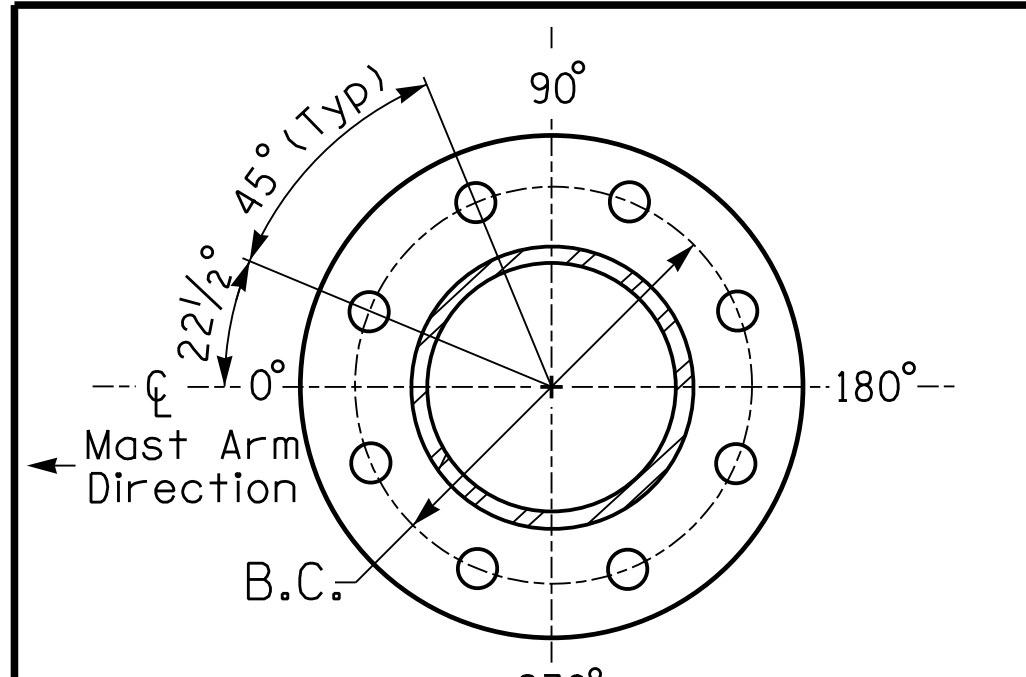

8 BOLT BASE PLATE DETAIL

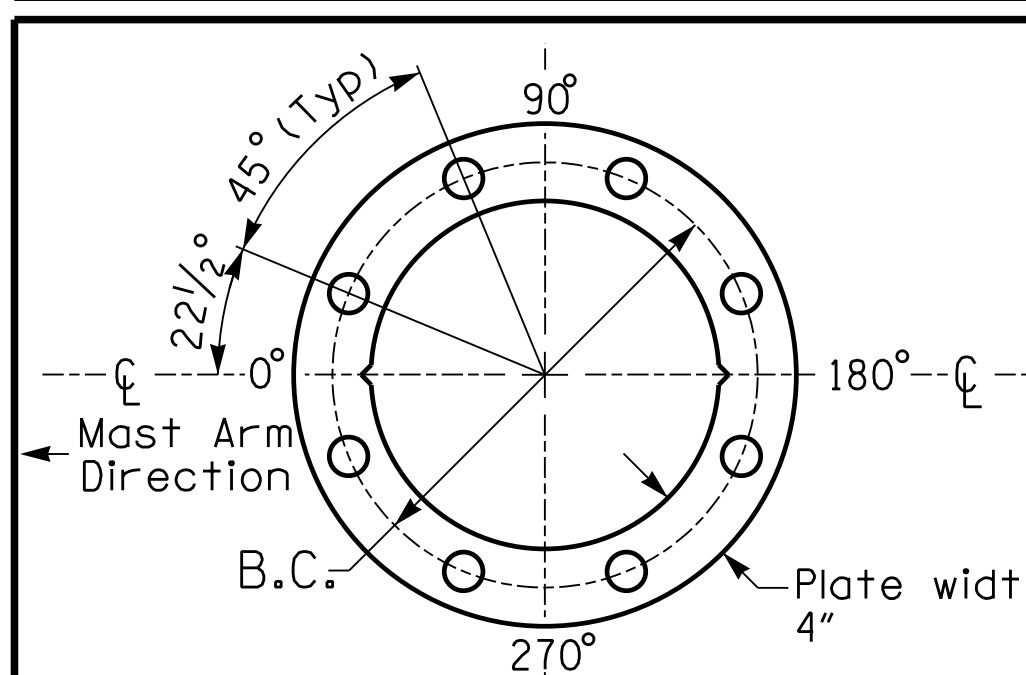

BASE PLATE TEMPLATE & ANCHOR BOLT LOCK PLATE DETAIL For 8 Bolt Base Plate

MAST ARM LOADING SCHEDULE

LOADING SYMBOL	DESCRIPTION	AREA	SIZE	WEIGHT
	RIGID MOUNTED SIGNAL HEAD 12"-3 SECTION-WITH BACKPLATE	9.3 S.F.	25.5" W X 52.5" L	60 LBS
	RIGID MOUNTED SIGNAL HEAD 12"-4 SECTION-WITH BACKPLATE	11.5 S.F.	25.5" W X 66.0" L	74 LBS
	RIGID MOUNTED SIGNAL HEAD 12"-5 SECTION-WITH BACKPLATE	16.3 S.F.	42.0" W X 56.0" L	103 LBS
	SIGN RIGID MOUNTED	7.5 S.F.	30.0" W X 36.0" L	14 LBS
	STREET NAME SIGN RIGID MOUNTED	16.0 S.F.	24.0" W X 96.0" L	36 LBS

NOTES

DESIGN REFERENCE MATERIAL

- Design the traffic signal structure and foundation in accordance with:
 - The 6th Edition 2013 AASHTO "Standard Specifications for Structural Supports for Highway Signs, Luminaires, and Traffic Signals, including all of the latest interim revisions.
 - The 2018 NCDOT "Standard Specifications for Roads and Structures." The latest addenda to the specifications can be found in the traffic signal project special provisions.
 - The 2018 NCDOT Roadway Standard Drawings.
 - The traffic signal project plans and special provisions.
 - The NCDOT "Metal Pole Standards" located at the following NCDOT website: <https://connect.ncdot.gov/resources/safety/Pages/ITS-Design-Resources.aspx>

DESIGN REQUIREMENTS

- Design the traffic signal structure using the loading conditions shown in the elevation views. These are anticipated worst case "design loads" and may not represent the actual loads that will be applied at the time of the installation. The contractor should refer to the traffic signal plans for the actual loads that will be applied at the time of the installation.
- Design all signal supports using stress ratios that do not exceed 0.9.
- The camber design for the mast arm deflection should provide an appearance of a low pitched arch where the tip or the free end of the mast arm does not deflect below horizontal when fully loaded.
- A clamp-type bolted mast arm-to-pole connection may be used instead of the welded ring stiffened box connection shown as long as the connection meets all of the design requirements.
- Design base plate with 8 anchor bolt holes. Provide 2 inch x 60 inch anchor bolts.
- The mast arm attachment height (H1) shown is based on the following design assumptions:
 - Mast arm slope and deflection are not considered in determining the arm attachment height as they are assumed to offset each other.
 - Signal heads are rigidly mounted and vertically centered on the mast arm.
 - The roadway clearance height for design is as shown in the elevation views.
 - The top of the pole base plate is 0.75 feet above the ground elevation.
 - Refer to the Elevation Data Chart for the elevation differences between the proposed foundation ground level and the high point of the roadway.
- The pole manufacturer will determine the total height (H2) of each pole using the greater of the following:
 - Mast arm attachment height (H1) plus 2 feet, or
 - H1 plus 1/2 of the total height of the mast arm attachment assembly plus 1 foot.
- If pole location adjustments are required, the contractor must gain approval from the Engineer as this may affect the mast arm lengths and arm attachment heights. The contractor may contact the Signal Design Section Senior Structural Engineer for assistance at (919) 814-5000.
- The contractor is responsible for verifying that the mast arm length shown will allow proper positioning of the signal heads over the roadway.
- The contractor is responsible for providing soil penetration testing data (SPT) to the pole manufacturer so site specific foundations can be designed.

NCDOT Wind Zone 2 (130 mph)

DOCUMENT NOT CONSIDERED FINAL UNLESS ALL SIGNATURES COMPLETED

	NC 906 (Midway Road) at NC 211 Northbound Ramp/ Midway Commons Driveway		
	Division 03 Brunswick Co. Southport		
PLAN DATE: June 2017	REVIEWED BY: A.D. Klinskyk		
PREPARED BY: A.H. Thornburg	REVIEWED BY: N.R. Simmons		
SCALE: 0 N/A N/A	REVISIONS:	INIT. DATE	DATE: 9/10/2021
			SIGNATURE: N. R. Simmons DATE: 9/10/2021 SIG. INVENTORY NO. 03-1122

DEFAULT PHASING DIAGRAM

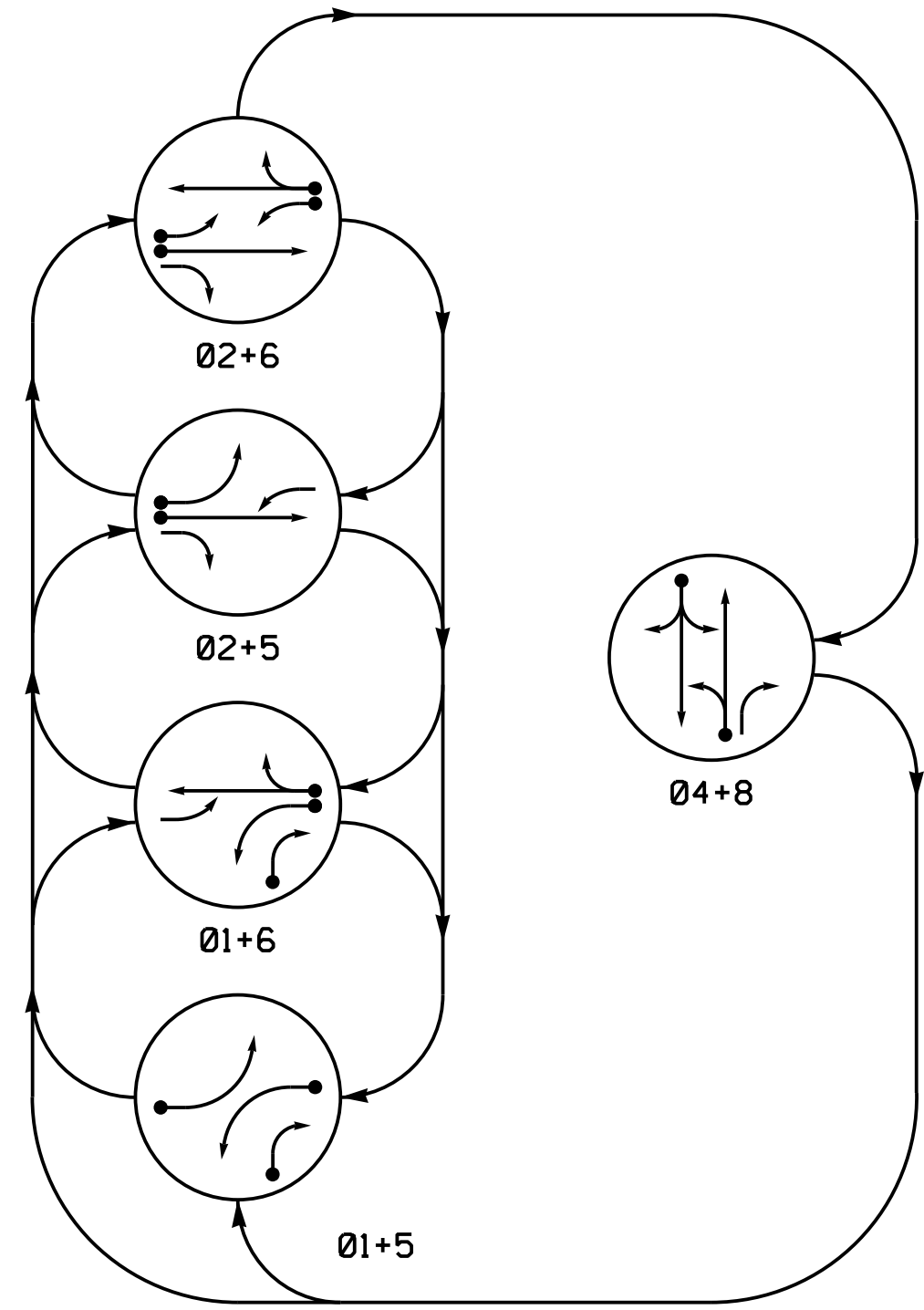

ALTERNATE PHASING DIAGRAM

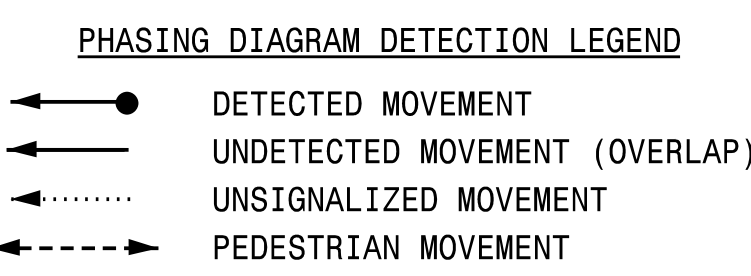
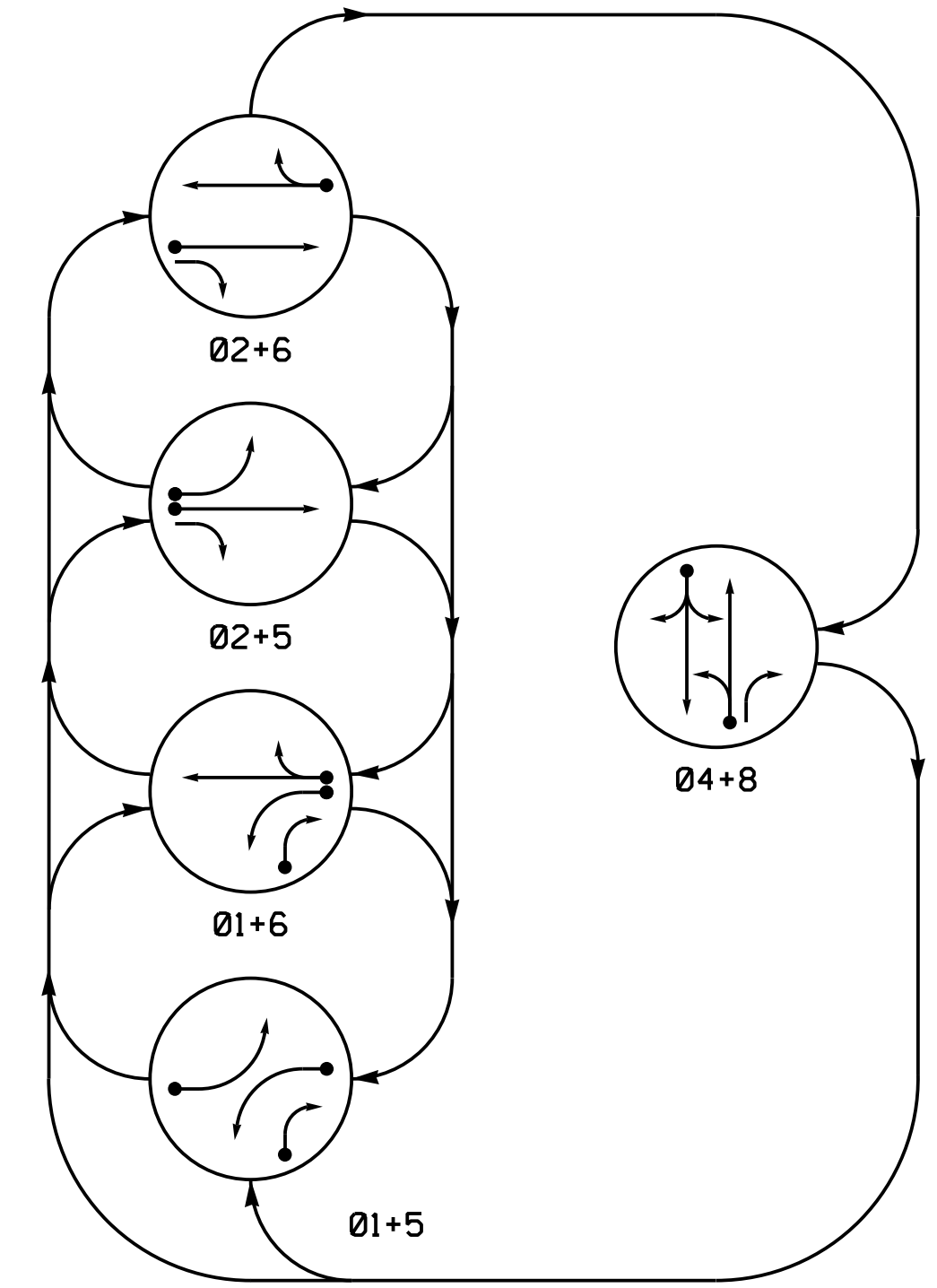

DEFAULT PHASING TABLE OF OPERATION

SIGNAL FACE	PHASE					
	01+5	01+6	02+5	02+6	04+8	F
11	-	-	F	F	R	Y
21,22	R	R	G	G	R	Y
41,42	R	R	R	R	G	R
51	-	F	F	F	R	Y
61,62	R	G	R	G	R	Y
81	R	R	R	R	G	R
82	R	R	R	R	G	R

ALTERNATE PHASING TABLE OF OPERATION

SIGNAL FACE	PHASE					
	01+5	01+6	02+5	02+6	04+8	F
11	-	-	R	R	R	Y
21,22	R	R	G	G	R	Y
41,42	R	R	R	R	G	R
51	-	R	R	R	R	Y
61,62	R	G	R	G	R	Y
81	R	R	R	R	G	R
82	R	R	R	R	G	R

OASIS 2070 LOOP & DETECTOR INSTALLATION CHART

LOOP	SIZE (FT)	DISTANCE FROM STOPBAR (FT)	TURNS	DETECTOR PROGRAMMING								
				NEW LOOP	PHASE	CALLING	EXTENSION	FULL TIME DELAY	STRETCH TIME	DELAY TIME	SYSTEM LOOP	NEW CARD
1A	6X40	0	*	*	1	Y	Y	-	-	***15	-	Y
1B	6X40	0	*	*	1	Y	Y	-	-	15	-	Y
2A	6X6	420	*	*	2	Y	Y	-	-	-	-	Y
4A	6X40	0	*	*	4	Y	Y	-	-	-	-	Y
5A	6X40	0	*	*	5	Y	Y	-	-	***15	-	Y
6A	6X6	420	*	*	6	Y	Y	-	-	-	-	Y
8A	6X40	0	*	*	8	Y	Y	-	-	-	-	Y

5 Phase Fully Actuated Isolated

NOTES

- Refer to "Roadway Standard Drawings NCDOT" dated January 2018 and "Standard Specifications for Roads and Structures" dated January 2018.
- Do not program signal for late night flashing operation unless otherwise directed by the Engineer.
- Phase 1 and/or phase 5 may be lagged.
- Set all detector units to presence mode.
- The Division Traffic Engineer will determine the hours of use for each phasing plan.
- Locate new cabinet so as not to obstruct sight distance of vehicles turning right on red.
- Incorporate Microwave Detection system for vehicle detection.
- Provide the Engineer with the Manufacturer's approved Microwave Detection locations and mounting heights to obtain detection zones as shown.

* Multizone Microwave Detection.
 ** Disable phase 2 and 6 call for 1A and 5A during alternate phasing operation.
 *** Reduce delay to 3 seconds during alternate phasing operation.

SIGNAL FACE I.D.

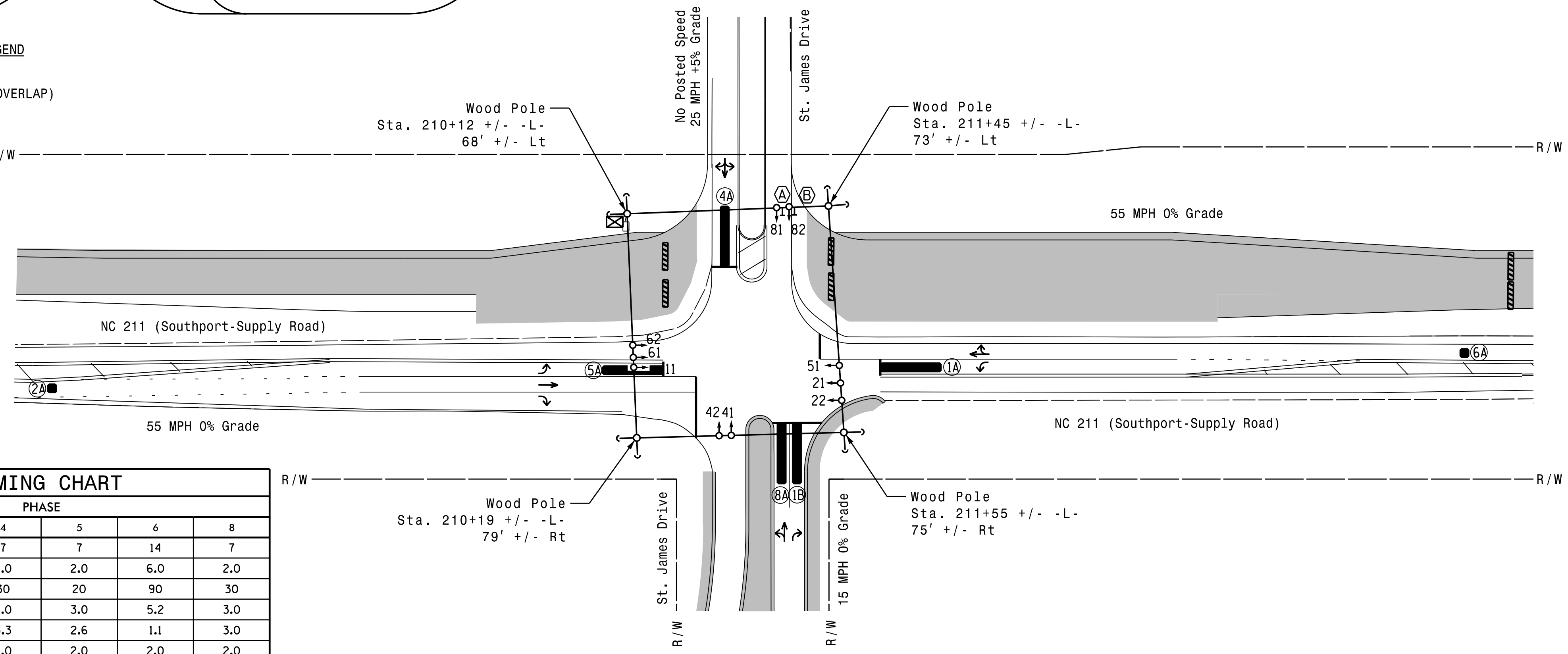
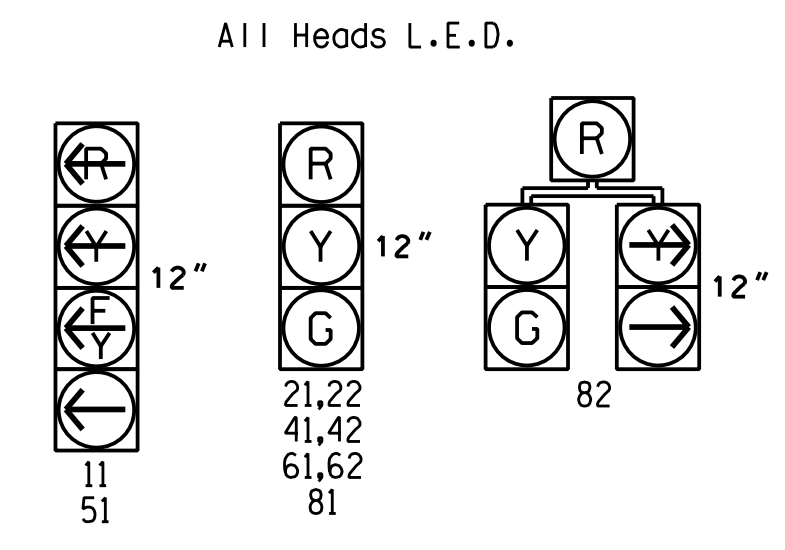

OASIS 2070 TIMING CHART

FEATURE	PHASE					
	1	2	4	5	6	8
Min Green 1 *	7	14	7	7	14	7
Extension 1 *	2.0	6.0	2.0	2.0	6.0	2.0
Max Green 1 *	20	90	30	20	90	30
Yellow Clearance	3.0	5.2	3.0	3.0	5.2	3.0
Red Clearance	3.3	1.1	3.3	2.6	1.1	3.0
Red Revert	2.0	2.0	2.0	2.0	2.0	2.0
Walk 1 *	-	-	-	-	-	-
Don't Walk 1	-	-	-	-	-	-
Seconds Per Actuation *	-	2.5	-	-	2.5	-
Max Variable Initial *	-	46	-	-	46	-
Time Before Reduction *	-	15	-	-	15	-
Time To Reduce *	-	30	-	-	30	-
Minimum Gap	-	3.4	-	-	3.4	-
Recall Mode	-	MIN RECALL	-	-	MIN RECALL	-
Vehicle Call Memory	-	YELLOW	-	-	YELLOW	-
Dual Entry	-	-	ON	-	-	ON
Simultaneous Gap	ON	ON	ON	ON	ON	ON

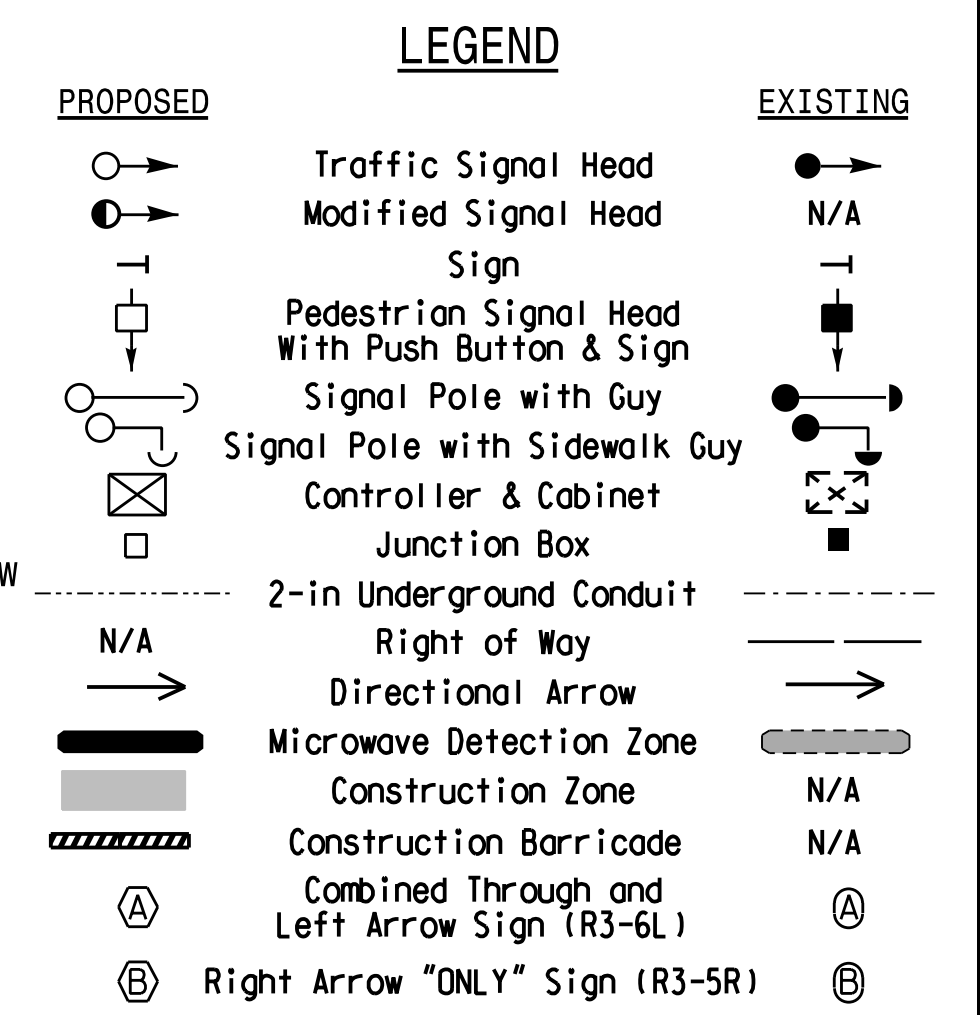

Signal Upgrade
 Temporary Design 1
 Construction Phase 1,1a-1e

DOCUMENT NOT CONSIDERED FINAL UNLESS ALL SIGNATURES COMPLETED

Prepared for: **TRANSPORTATION MOBILITY AND SAFETY DIVISION**
 STATE OF NORTH CAROLINA
 DEPARTMENT OF TRANSPORTATION
 SIGNAL DESIGN SECTION

750 N. Greenfield Pkwy, Garner, NC 27529

NC 211 (Southport-Supply Road) at St. James Drive

Division 03 Brunswick Co. Southport

PLAN DATE: June 2017 REVIEWED BY: A.D. Klinksiek

PREPARED BY: A.H. Thornburg REVIEWED BY: N.R. Simmons

REVISIONS: INIT. DATE

Signature: *Natasha Simmons* 9/10/2021

SIG. INVENTORY NO. 03-097771

HNTB HNTB NORTH CAROLINA, P.C.
 343 E. Six Forks Road, Suite 200
 Raleigh, North Carolina 27609
 NC License No: C-1554
 (919) 546-8997

* These values may be field adjusted. Do not adjust Min Green and Extension times for phases 2 and 6 lower than what is shown. Min Green for all other phases should not be lower than 4 seconds.

EDI MODEL 2018ECL-NC CONFLICT MONITOR PROGRAMMING DETAIL

(remove jumpers and set switches as shown)

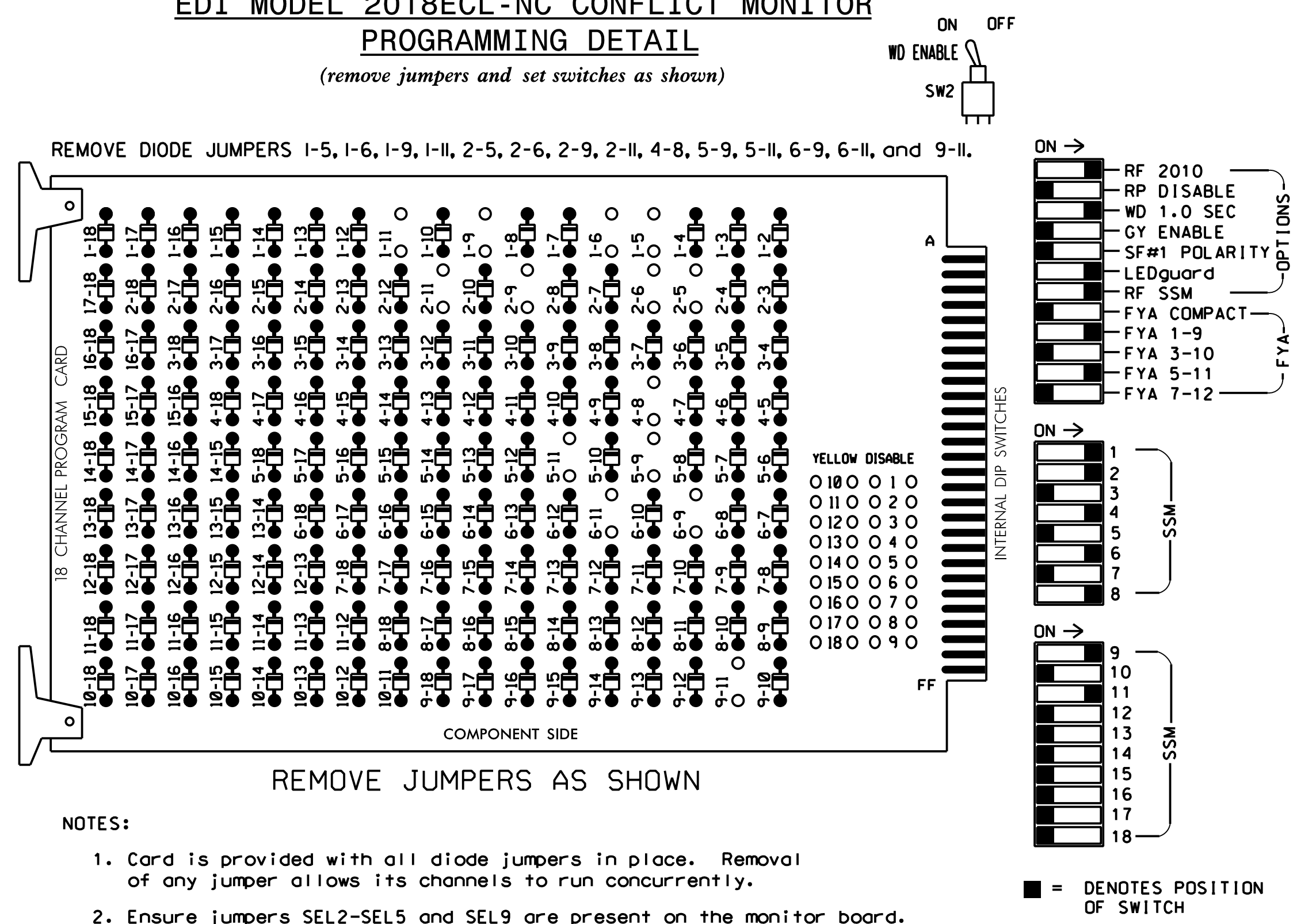

NOTES

- To prevent "flash-conflict" problems, insert red flash program blocks for all unused vehicle load switches in the output file. The installer shall verify that signal heads flash in accordance with the Signal Plans.
- Program phases 4 and 8 for Dual Entry.
- Enable Simultaneous Gap-Out for all Phases.
- Program phases 2 and 6 for Variable Initial and Gap Reduction.
- Program phases 2 and 6 for Startup In Green.
- Program phases 2 and 6 for Yellow Flash, and overlap 1 as Wag Overlaps.
- If this signal will be managed by an ATMS software, enable controller and detector logging for all detectors used at this location.

EQUIPMENT INFORMATION

CONTROLLER.....2070E
 CABINET.....332 W/AUX
 SOFTWARE.....ECONOLITE OASIS
 CABINET MOUNT.....BASE
 OUTPUT FILE POSITIONS...18 WITH AUX. OUTPUT FILE
 LOAD SWITCHES USED.....S1,S2,S5,S7,S8,S11,
 AUX S1,AUX S4
 PHASES USED.....1,2,4,5,6,8
 OVERLAP "A".....1+2
 OVERLAP "B".....NOT USED
 OVERLAP "C".....5+6
 OVERLAP "D".....NOT USED

SIGNAL HEAD HOOK-UP CHART

LOAD SWITCH NO.	S1	S2	S3	S4	S5	S6	S7	S8	S9	S10	S11	S12	AUX S1	AUX S2	AUX S3	AUX S4	AUX S5	AUX S6
CMU CHANNEL NO.	1	2	13	3	4	14	5	6	15	7	8	16	9	10	17	11	12	18
PHASE	1	2	2 PED	3	4	4 PED	5	6	6 PED	7	8	8 PED	OLA	OLB	SPARE	OLC	OLD	SPARE
SIGNAL HEAD NO.	11	82	21,22	NU	NU	41,42	NU	51	61,62	NU	NU	81,82	NU	11	NU	NU	51	NU
RED		*	128			101			134			107						
YELLOW			129			102		*	135			108						
GREEN			130			103			136			109						
RED ARROW													A121				A114	
YELLOW ARROW		126											A122				A115	
FLASHING YELLOW ARROW													A123				A116	
GREEN ARROW	127	127							133									

NU = Not Used
 * Denotes install load resistor. See load resistor installation detail this sheet.
 ★ See pictorial of head wiring in detail this sheet.

INPUT FILE POSITION LAYOUT (front view)

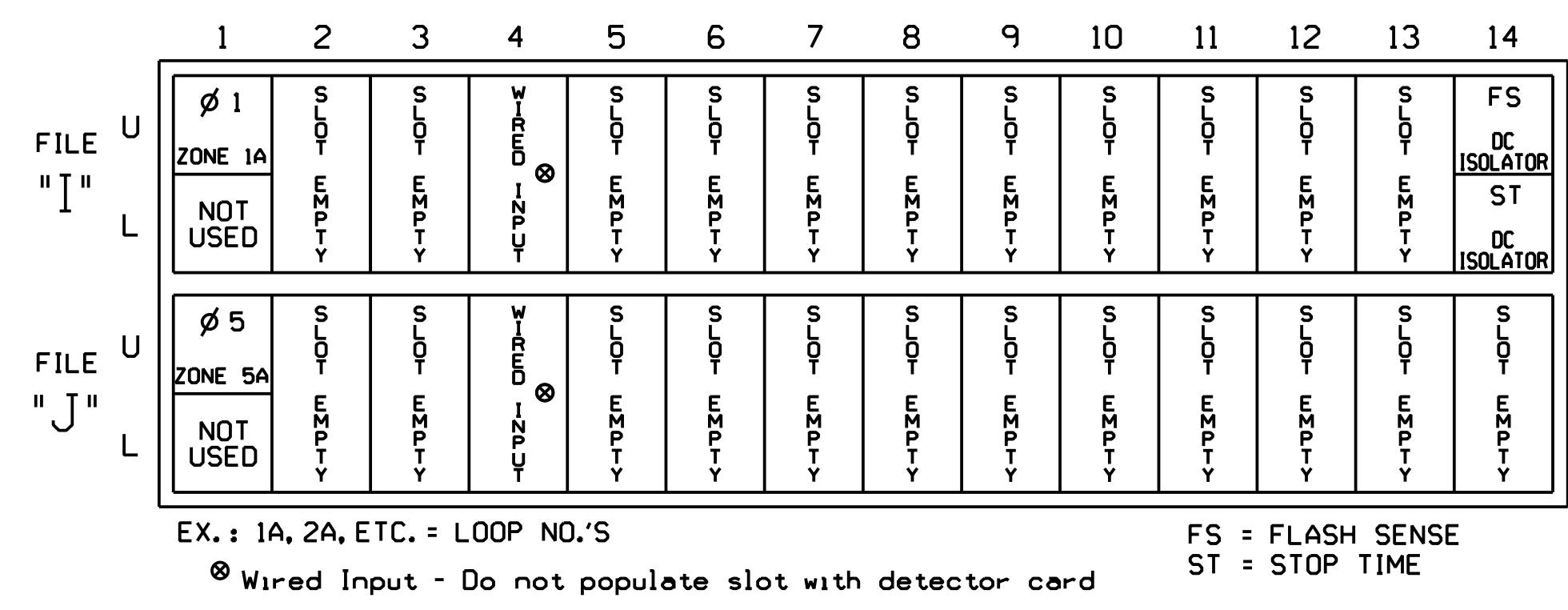

INPUT FILE CONNECTION & PROGRAMMING CHART

LOOP NO.	LOOP TERMINAL	INPUT FILE POS.	PIN NO.	INPUT ASSIGNMENT NO.	DETECTOR NO.	NEMA PHASE	CALL	EXTEND	FULL TIME DELAY	STRETCH TIME	DELAY TIME
ZONE 1A ¹	★★	I1U	56	18	1	1	Y	Y			15
	-	J4U	48	10★	26	6	Y	Y	Y		3
ZONE 5A ²	★★	J1U	55	17	5	5	Y	Y			15
	-	I4U	47	9★	22	2	Y	Y	Y		3

¹Add jumper from I1-W to J4-W, on rear of input file.
²Add jumper from J1-W to I4-W, on rear of input file.
 ★ See Input Page Assignment programming details on sheets 3 and 4.
 ★★ Multizone Microwave Detector Zone. See Special Detector Note.

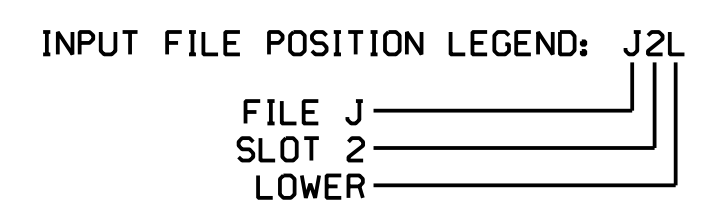

SPECIAL DETECTOR NOTE

Install a microwave detection system for vehicle detection. Perform installation according to manufacturer's directions and NCDOT engineer-approved mounting locations to accomplish the detection schemes shown on the Signal Design Plans.

For loops 1A and 5A detector card placement and slots reserved for wired inputs are typical for a NCDOT installation. Inputs associated with these slots are compatible with the time of day instructions located on sheets 3, 4, and 5 of this electrical detail.

FYA SIGNAL WIRING DETAIL (wire signal heads as shown)

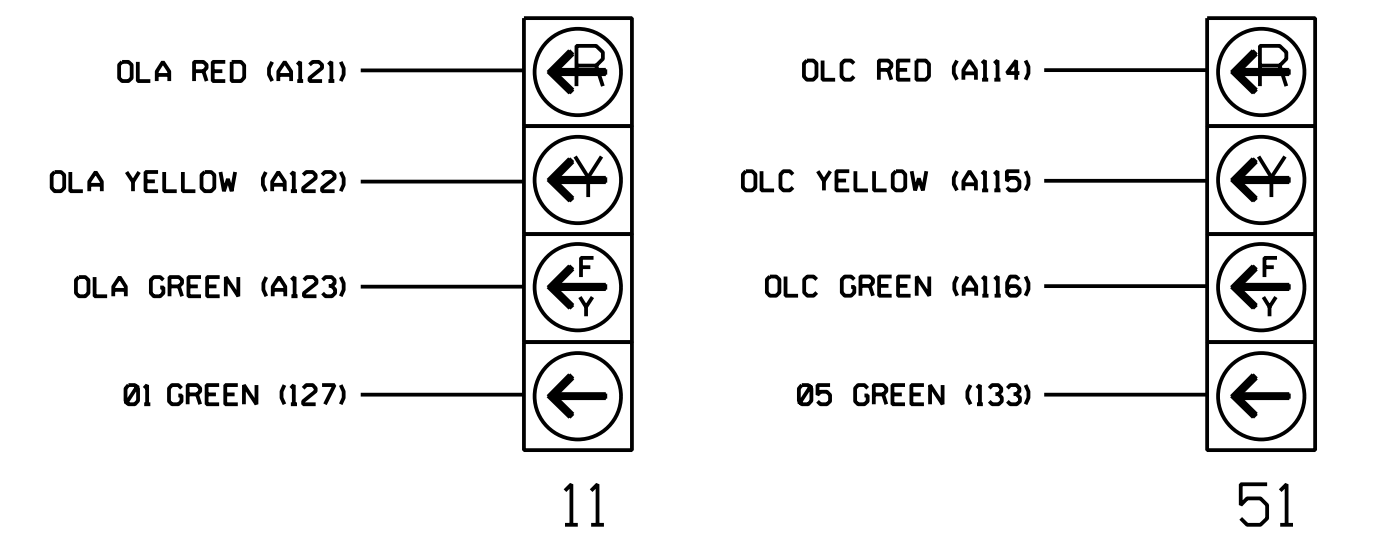

NOTE
 The sequence display for signal heads 11 and 51 requires special logic programming. See sheet 2 for programming instructions.

LOAD RESISTOR INSTALLATION DETAIL (install resistors as shown)

ACCEPTABLE VALUES

VALUE (ohms)	WATTAGE
1.5K - 1.9K	25W (min)
2.0K - 3.0K	10W (min)

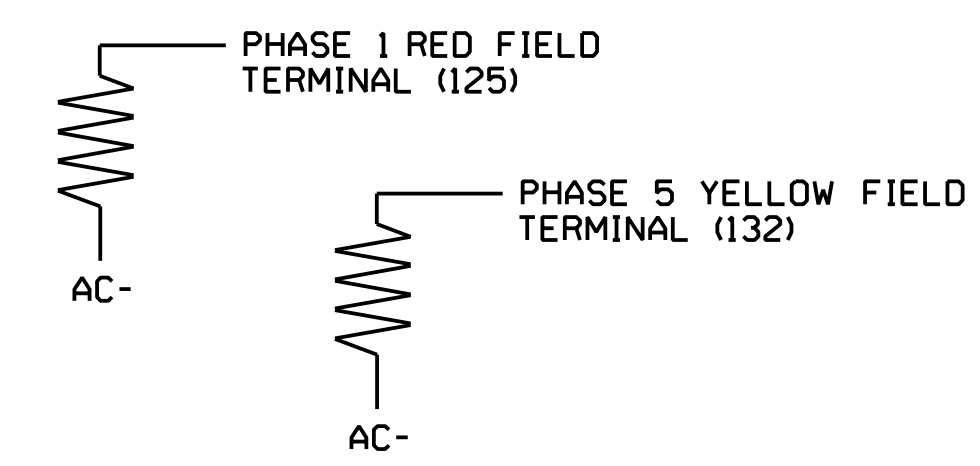

THIS ELECTRICAL DETAIL IS FOR THE SIGNAL DESIGN: 03-0977T1
 DESIGNED: June 2017
 SEALED: 9/10/2021
 REVISED: N/A

Electrical Detail - Sheet 1 of 5
 Signal Upgrade
 Temporary Design 1

DOCUMENT NOT CONSIDERED FINAL UNLESS ALL SIGNATURES COMPLETED

Prepared for:

750 N. Greenfield Pkwy, Corner, NC 27529

NC 211 (Southport-Supply Road) at St. James Drive

Division 03 Brunswick Co. Southport

PLAN DATE: June 2017 REVIEWED BY: A.D. Klinksiek
 PREPARED BY: A.H. Thornburg REVIEWED BY: N.R. Simmons

REVISIONS	INIT.	DATE

Signature:

9/10/2021

SIG. INVENTORY NO. 03-0977T1

LOGICAL I/O PROCESSOR PROGRAMMING DETAIL TO PRODUCE SPECIAL FYA-PPLT SIGNAL SEQUENCE

(program controller as shown below)

- FROM MAIN MENU PRESS '2' (PHASE CONTROL), THEN '1' (PHASE CONTROL FUNCTIONS). SCROLL TO THE BOTTOM OF THE MENU AND ENABLE ACT LOGIC COMMANDS 1, 2, 3, 4, 5 AND 6.
- FROM MAIN MENU PRESS '6' (OUTPUTS), THEN '3' (LOGICAL I/O PROCESSOR).

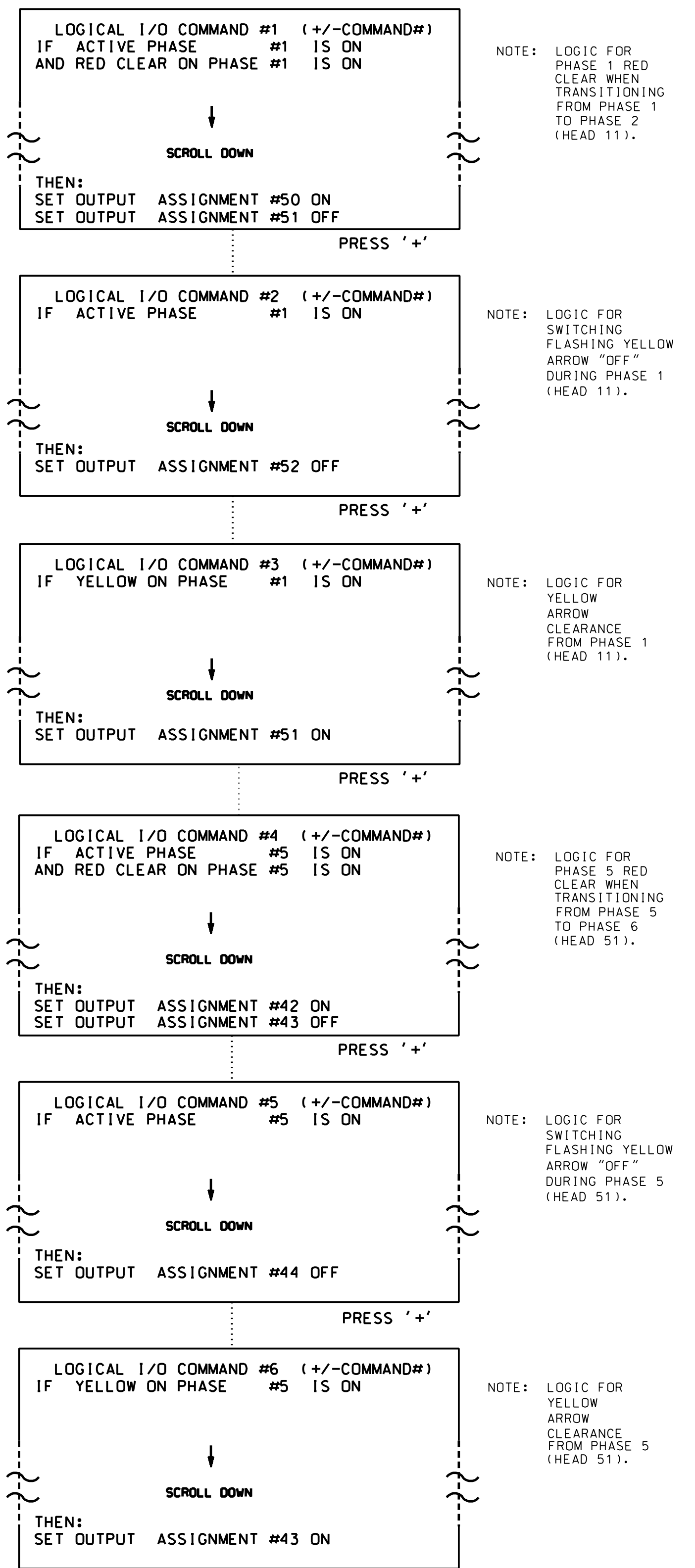

LOGIC I/O PROCESSOR PROGRAMMING COMPLETE

OVERLAP PROGRAMMING DETAIL FOR DEFAULT PHASING

(program controller as shown below)

FROM MAIN MENU PRESS '8' (OVERLAPS), THEN '1' (VEHICLE OVERLAP SETTINGS).

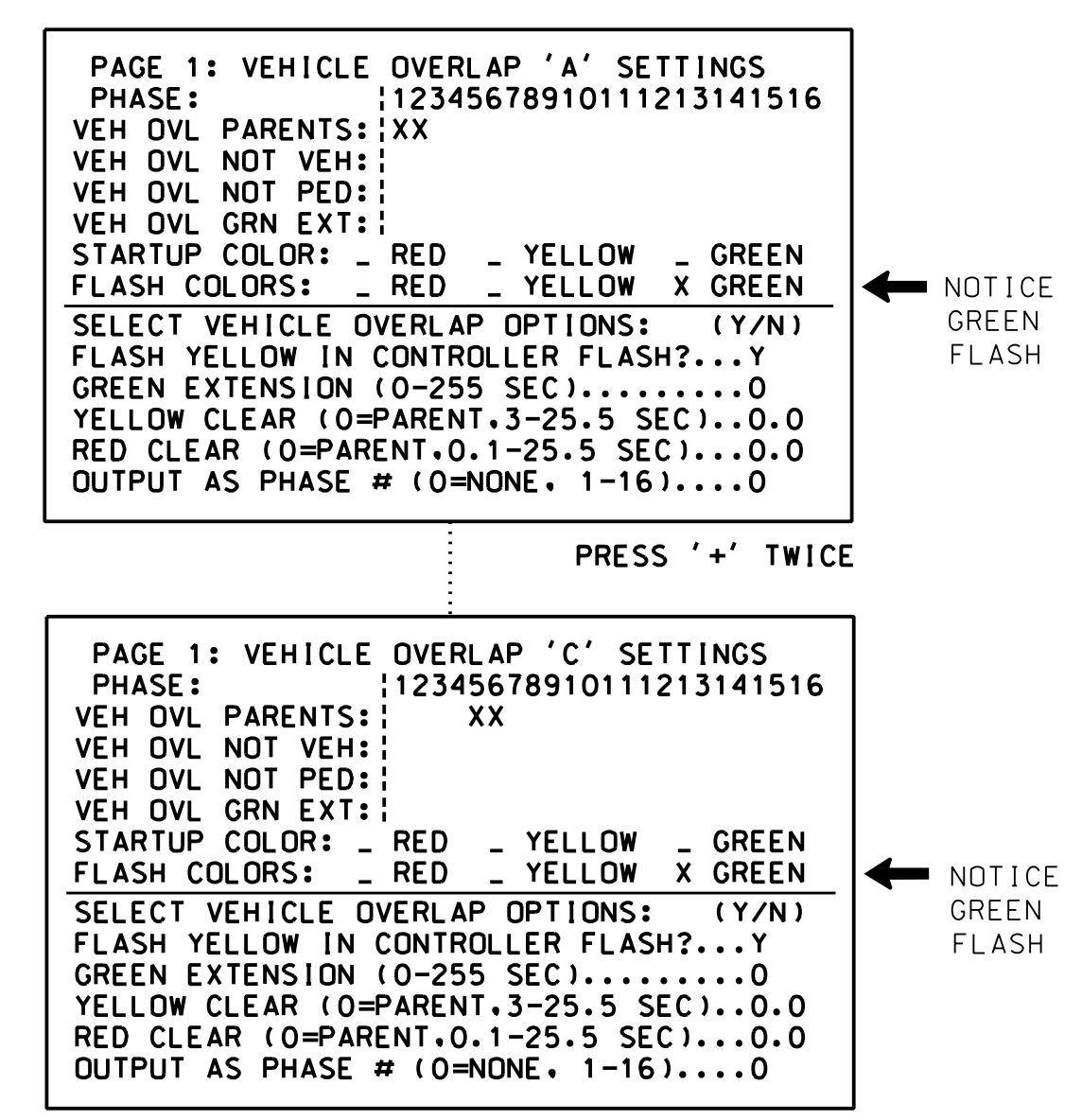

OVERLAP PROGRAMMING COMPLETE

OVERLAP PROGRAMMING DETAIL FOR ALTERNATE PHASING

(program controller as shown below)

FROM MAIN MENU PRESS '8' (OVERLAPS), THEN '1' (VEHICLE OVERLAP SETTINGS). PRESS 'NEXT' TO ADVANCE TO PAGE 2.

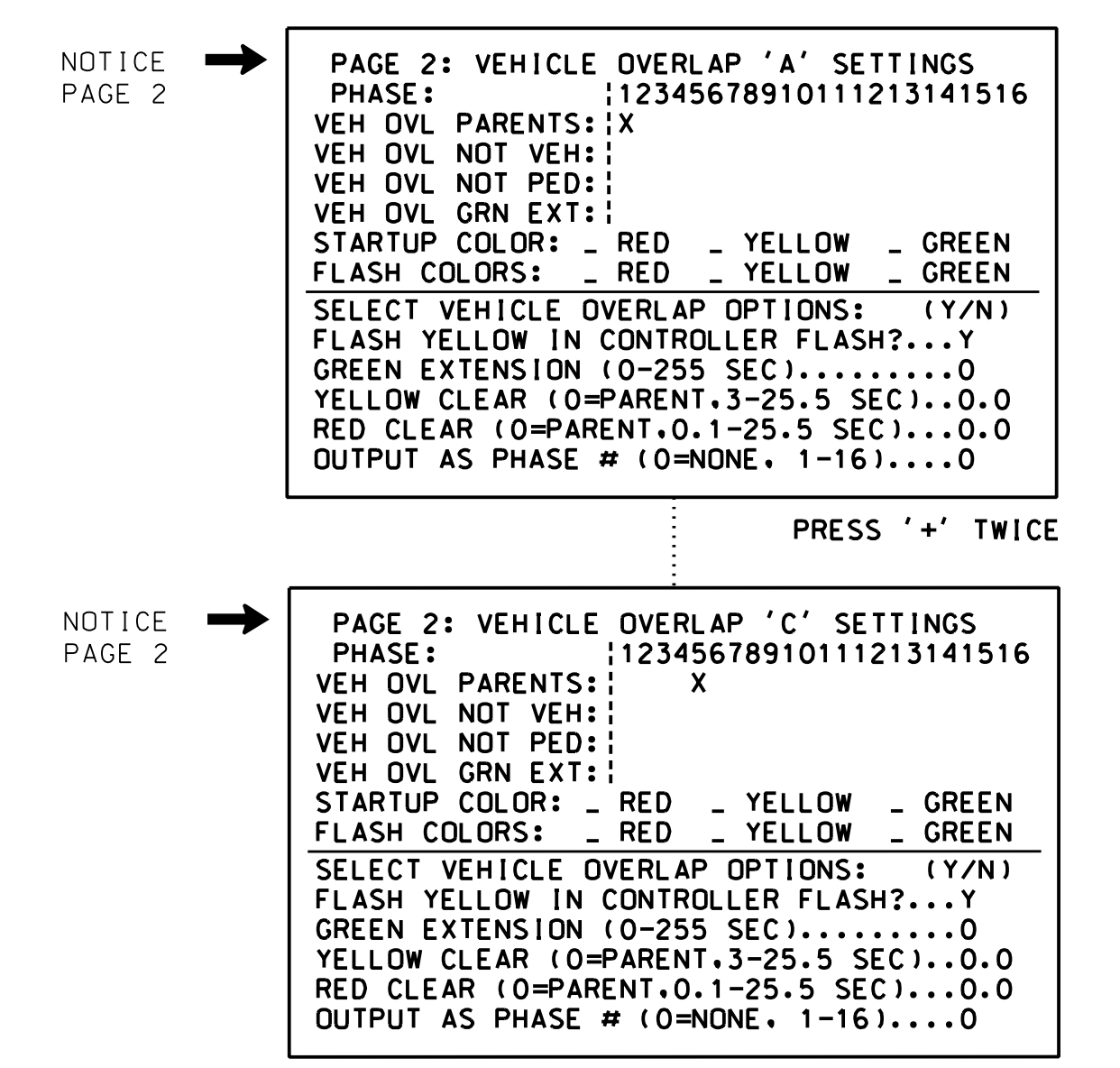

OVERLAP PROGRAMMING COMPLETE

OUTPUT REFERENCE SCHEDULE	
USE TO INTERPRET LOGIC PROCESSOR	
OUTPUT 42 =	Overlap C Red
OUTPUT 43 =	Overlap C Yellow
OUTPUT 44 =	Overlap C Green
OUTPUT 50 =	Overlap A Red
OUTPUT 51 =	Overlap A Yellow
OUTPUT 52 =	Overlap A Green

THIS ELECTRICAL DETAIL IS FOR THE SIGNAL DESIGN: 03-0977T1
DESIGNED: June 2017
SEALED: 9/10/2021
REVISED: N/A

Electrical Detail - Sheet 2 of 5
Signal Upgrade
Temporary Design 1

DOCUMENT NOT CONSIDERED FINAL
UNLESS ALL SIGNATURES COMPLETED

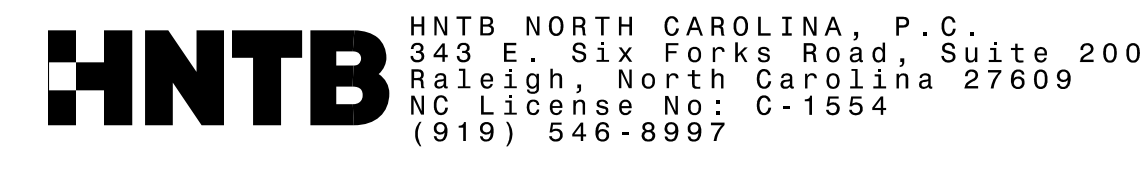

	Prepared for: NC 211 (Southport-Supply Road) at St. James Drive		
	Division 03 Brunswick Co. Southport	PLAN DATE: June 2017 REVIEWED BY: A.D. Klinksiek PREPARED BY: A.H. Thornburg REVIEWED BY: N.R. Simmons	
REVISIONS		INIT. DATE	Signature: <i>Natasha Simmons</i> DATE: 9/10/2021 SIGNATURE NO. 03-0977T1

INPUT PAGE 2 ASSIGNMENT PROGRAMMING DETAIL FOR ALTERNATE PHASING - LOOP 1A

(program controller as shown below)

- NOTES: 1. THIS PROGRAMMING APPLIES FOR INPUT PAGE 2 ONLY. INPUT PAGE 1 WILL USE STANDARD DEFAULT SETTINGS. THIS PROGRAMMING IS NECESSARY FOR PROPER DETECTOR OPERATION DURING ALTERNATE PHASING OPERATION.
2. THE FIRST TASK THIS PROGRAMMING ACCOMPLISHES IS THE DISABLING OF INPUT #10 (DETECTOR 26) SO THAT A VEHICLE CALL WILL NOT BE PLACED TO PHASE 6 DURING ALTERNATE PHASING OPERATION. THE SECOND TASK THIS PROGRAMMING ACCOMPLISHES IS THAT IT REASSIGNS DETECTOR 51 TO INPUT #18 SO THAT THE DELAY ON LOOP 1A CAN BE REDUCED FROM 15 SECONDS TO 3 SECONDS.

FROM MAIN MENU PRESS '5' (INPUTS), THEN PRESS 'NEXT' TO GET TO INPUT PAGE '2'. PRESS THE '+' KEY UNTIL INPUT 10 IS REACHED.

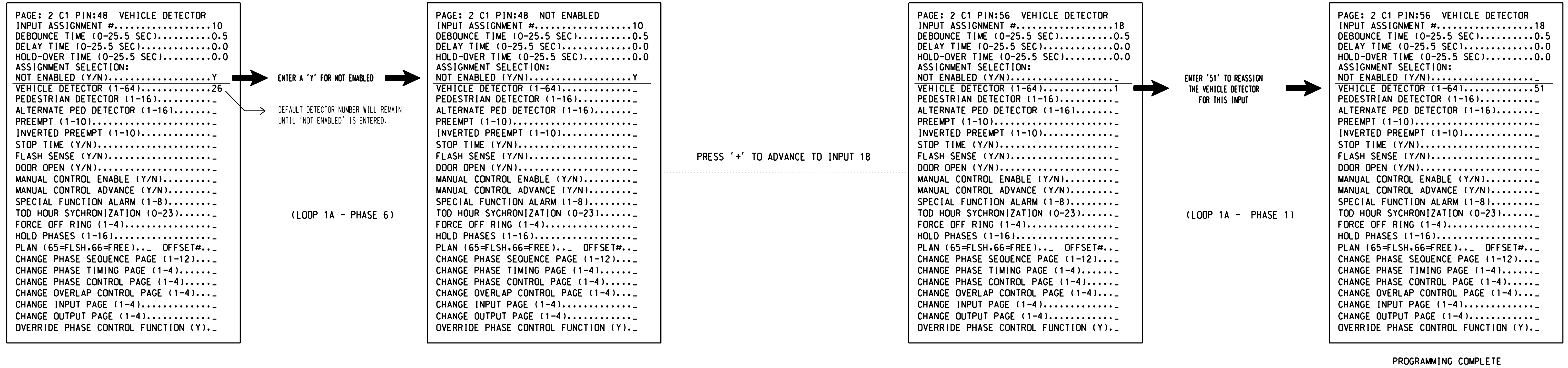

SPECIAL DETECTOR PROGRAMMING DETAIL - LOOP 1A (ALT.)

(program controller as shown below)

FROM MAIN MENU PRESS '7' (DETECTORS), THEN PRESS '1' FOR VEHICLE DETECTORS. PRESS THE '-' KEY TO GET TO VEHICLE DETECTOR #51.

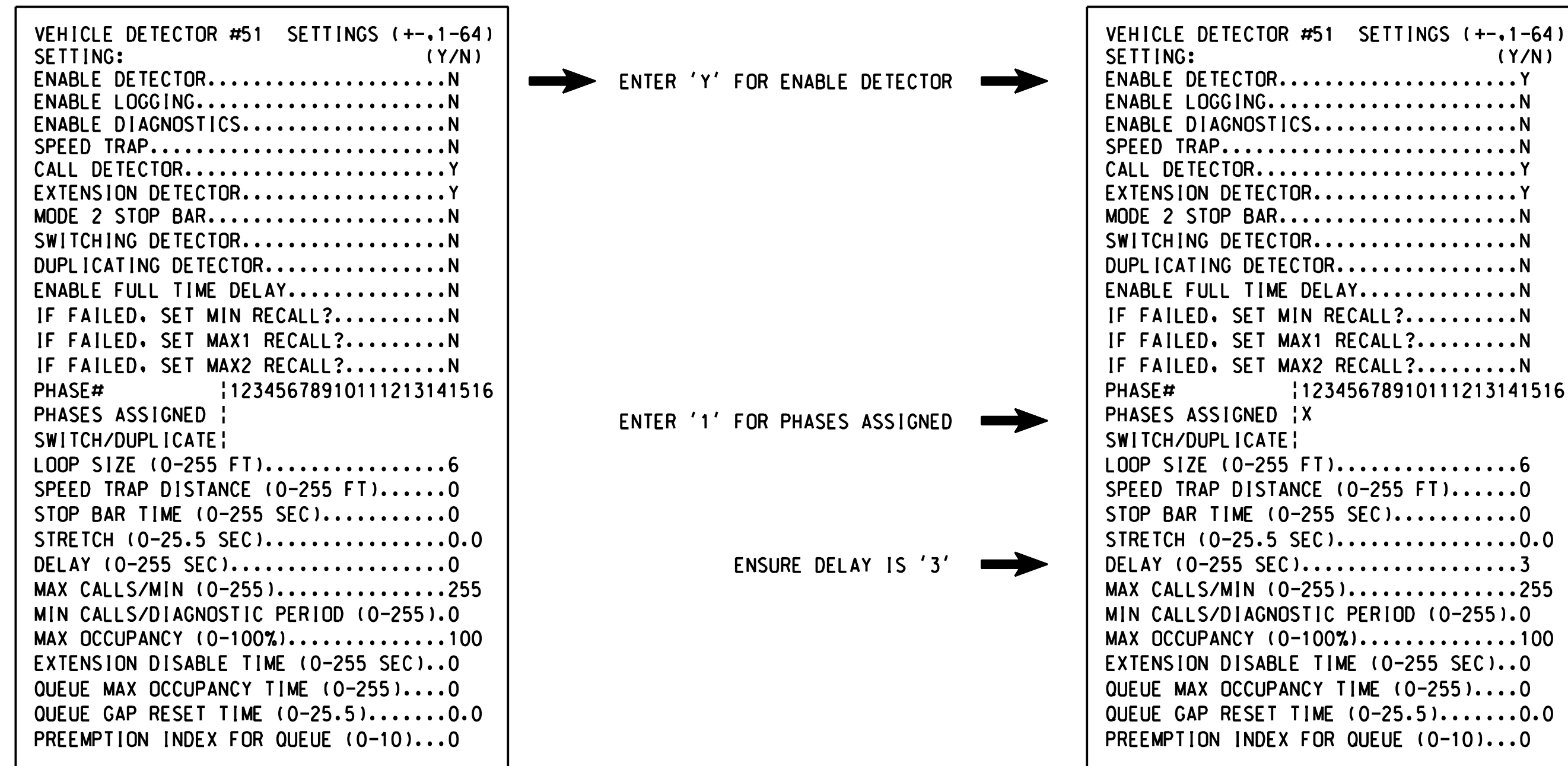

NOTE: DETECTOR IS PROGRAMMED PER THE INPUT FILE CONNECTION AND PROGRAMMING CHART SHOWN ON SHEET 1.

THIS ELECTRICAL DETAIL IS FOR THE SIGNAL DESIGN: 03-09771
DESIGNED: June 2017
SEALED: 9/10/2021
REVISED: N/A

Electrical Detail - Sheet 3 of 5
Signal Upgrade
Temporary Design 1

DOCUMENT NOT CONSIDERED FINAL UNLESS ALL SIGNATURES COMPLETED

	Prepared for: NC 211 (Southport-Supply Road) at St. James Drive		
	Division 03 Brunswick Co. Southport	PLAN DATE: June 2017 REVIEWED BY: A.D. Klinksiek PREPARED BY: A.H. Thornburg REVIEWED BY: N.R. Simmons	
REVISIONS		INIT. DATE	SIGNATURE DATE
_____		_____	_____

INPUT PAGE 2 ASSIGNMENT PROGRAMMING DETAIL FOR ALTERNATE PHASING - LOOP 5A

(program controller as shown below)

- NOTES: 1. THIS PROGRAMMING APPLIES FOR INPUT PAGE 2 ONLY. INPUT PAGE 1 WILL USE STANDARD DEFAULT SETTINGS. THIS PROGRAMMING IS NECESSARY FOR PROPER DETECTOR OPERATION DURING ALTERNATE PHASING OPERATION. 2. THE FIRST TASK THIS PROGRAMMING ACCOMPLISHES IS THE DISABLING OF INPUT #9 (DETECTOR 22) SO THAT A VEHICLE CALL WILL NOT BE PLACED TO PHASE 2 DURING ALTERNATE PHASING OPERATION. THE SECOND TASK THIS PROGRAMMING ACCOMPLISHES IS THAT IT REASSIGNS DETECTOR 55 TO INPUT #17 SO THAT THE DELAY ON LOOP 5A CAN BE REDUCED FROM 15 SECONDS TO 3 SECONDS.

FROM MAIN MENU PRESS '5' (INPUTS), THEN PRESS 'NEXT' TO GET TO INPUT PAGE '2'. PRESS THE '+' KEY UNTIL INPUT 9 IS REACHED.

PAGE: 2 C1 PIN:47 VEHICLE DETECTOR INPUT ASSIGNMENT #.....9 DEBOUNCE TIME (0-25.5 SEC).....0.5 DELAY TIME (0-25.5 SEC).....0.0 HOLD-OVER TIME (0-25.5 SEC).....0.0 ASSIGNMENT SELECTION: NOT ENABLED (Y/N).....Y VEHICLE DETECTOR (1-64).....22 PEDESTRIAN DETECTOR (1-16)..... ALTERNATE PED DETECTOR (1-16)..... PREEMPT (1-10)..... INVERTED PREEMPT (1-10)..... STOP TIME (Y/N)..... FLASH SENSE (Y/N)..... DOOR OPEN (Y/N)..... MANUAL CONTROL ENABLE (Y/N)..... MANUAL CONTROL ADVANCE (Y/N)..... SPECIAL FUNCTION ALARM (1-8)..... TOD HOUR SYNCHRONIZATION (0-23)..... FORCE OFF RING (1-4)..... HOLD PHASES (1-16)..... PLAN (65=FLSH,66=FREE)..... OFFSET#... CHANGE PHASE SEQUENCE PAGE (1-12).... CHANGE PHASE TIMING PAGE (1-4)..... CHANGE PHASE CONTROL PAGE (1-4).... CHANGE OVERLAP CONTROL PAGE (1-4).... CHANGE INPUT PAGE (1-4)..... CHANGE OUTPUT PAGE (1-4)..... OVERRIDE PHASE CONTROL FUNCTION (Y)...

ENTER A 'Y' FOR NOT ENABLED
DEFAULT DETECTOR NUMBER WILL REMAIN UNTIL 'NOT ENABLED' IS ENTERED.

(LOOP 5A - PHASE 2)

PAGE: 2 C1 PIN:47 NOT ENABLED INPUT ASSIGNMENT #.....9 DEBOUNCE TIME (0-25.5 SEC).....0.5 DELAY TIME (0-25.5 SEC).....0.0 HOLD-OVER TIME (0-25.5 SEC).....0.0 ASSIGNMENT SELECTION: NOT ENABLED (Y/N).....Y VEHICLE DETECTOR (1-64)..... PEDESTRIAN DETECTOR (1-16)..... ALTERNATE PED DETECTOR (1-16)..... PREEMPT (1-10)..... INVERTED PREEMPT (1-10)..... STOP TIME (Y/N)..... FLASH SENSE (Y/N)..... DOOR OPEN (Y/N)..... MANUAL CONTROL ENABLE (Y/N)..... MANUAL CONTROL ADVANCE (Y/N)..... SPECIAL FUNCTION ALARM (1-8)..... TOD HOUR SYNCHRONIZATION (0-23)..... FORCE OFF RING (1-4)..... HOLD PHASES (1-16)..... PLAN (65=FLSH,66=FREE)..... OFFSET#... CHANGE PHASE SEQUENCE PAGE (1-12).... CHANGE PHASE TIMING PAGE (1-4)..... CHANGE PHASE CONTROL PAGE (1-4).... CHANGE OVERLAP CONTROL PAGE (1-4).... CHANGE INPUT PAGE (1-4)..... CHANGE OUTPUT PAGE (1-4)..... OVERRIDE PHASE CONTROL FUNCTION (Y)...

PRESS '+' TO ADVANCE TO INPUT 17

PAGE: 2 C1 PIN:55 VEHICLE DETECTOR INPUT ASSIGNMENT #.....17 DEBOUNCE TIME (0-25.5 SEC).....0.5 DELAY TIME (0-25.5 SEC).....0.0 HOLD-OVER TIME (0-25.5 SEC).....0.0 ASSIGNMENT SELECTION: NOT ENABLED (Y/N)..... VEHICLE DETECTOR (1-64).....5 PEDESTRIAN DETECTOR (1-16)..... ALTERNATE PED DETECTOR (1-16)..... PREEMPT (1-10)..... INVERTED PREEMPT (1-10)..... STOP TIME (Y/N)..... FLASH SENSE (Y/N)..... DOOR OPEN (Y/N)..... MANUAL CONTROL ENABLE (Y/N)..... MANUAL CONTROL ADVANCE (Y/N)..... SPECIAL FUNCTION ALARM (1-8)..... TOD HOUR SYNCHRONIZATION (0-23)..... FORCE OFF RING (1-4)..... HOLD PHASES (1-16)..... PLAN (65=FLSH,66=FREE)..... OFFSET#... CHANGE PHASE SEQUENCE PAGE (1-12).... CHANGE PHASE TIMING PAGE (1-4)..... CHANGE PHASE CONTROL PAGE (1-4).... CHANGE OVERLAP CONTROL PAGE (1-4).... CHANGE INPUT PAGE (1-4)..... CHANGE OUTPUT PAGE (1-4)..... OVERRIDE PHASE CONTROL FUNCTION (Y)...

ENTER '55' TO REASSIGN THE VEHICLE DETECTOR FOR THIS INPUT

(LOOP 5A - PHASE 5)

PAGE: 2 C1 PIN:55 VEHICLE DETECTOR INPUT ASSIGNMENT #.....17 DEBOUNCE TIME (0-25.5 SEC).....0.5 DELAY TIME (0-25.5 SEC).....0.0 HOLD-OVER TIME (0-25.5 SEC).....0.0 ASSIGNMENT SELECTION: NOT ENABLED (Y/N)..... VEHICLE DETECTOR (1-64).....55 PEDESTRIAN DETECTOR (1-16)..... ALTERNATE PED DETECTOR (1-16)..... PREEMPT (1-10)..... INVERTED PREEMPT (1-10)..... STOP TIME (Y/N)..... FLASH SENSE (Y/N)..... DOOR OPEN (Y/N)..... MANUAL CONTROL ENABLE (Y/N)..... MANUAL CONTROL ADVANCE (Y/N)..... SPECIAL FUNCTION ALARM (1-8)..... TOD HOUR SYNCHRONIZATION (0-23)..... FORCE OFF RING (1-4)..... HOLD PHASES (1-16)..... PLAN (65=FLSH,66=FREE)..... OFFSET#... CHANGE PHASE SEQUENCE PAGE (1-12).... CHANGE PHASE TIMING PAGE (1-4)..... CHANGE PHASE CONTROL PAGE (1-4).... CHANGE OVERLAP CONTROL PAGE (1-4).... CHANGE INPUT PAGE (1-4)..... CHANGE OUTPUT PAGE (1-4)..... OVERRIDE PHASE CONTROL FUNCTION (Y)...

PROGRAMMING COMPLETE

SPECIAL DETECTOR PROGRAMMING DETAIL - LOOP 5A (ALT.)

(program controller as shown below)

FROM MAIN MENU PRESS '7' (DETECTORS), THEN PRESS '1' FOR VEHICLE DETECTORS. PRESS THE '-' KEY TO GET TO VEHICLE DETECTOR #55.

VEHICLE DETECTOR #55 SETTINGS (+,-,1-64) SETTING: (Y/N) ENABLE DETECTOR.....N ENABLE LOGGING.....N ENABLE DIAGNOSTICS.....N SPEED TRAP.....N CALL DETECTOR.....Y EXTENSION DETECTOR.....Y MODE 2 STOP BAR.....N SWITCHING DETECTOR.....N DUPLICATING DETECTOR.....N ENABLE FULL TIME DELAY.....N IF FAILED, SET MIN RECALL?.....N IF FAILED, SET MAX1 RECALL?.....N IF FAILED, SET MAX2 RECALL?.....N PHASE# :12345678910111213141516 PHASES ASSIGNED : SWITCH/DUPLICATE: LOOP SIZE (0-255 FT).....6 SPEED TRAP DISTANCE (0-255 FT).....0 STOP BAR TIME (0-255 SEC).....0 STRETCH (0-25.5 SEC).....0.0 DELAY (0-255 SEC).....0.0 MAX CALLS/MIN (0-255).....255 MIN CALLS/DIAGNOSTIC PERIOD (0-255).....0 MAX OCCUPANCY (0-100%).....100 EXTENSION DISABLE TIME (0-255 SEC).....0 QUEUE MAX OCCUPANCY TIME (0-255).....0 QUEUE GAP RESET TIME (0-25.5).....0.0 PREEMPTION INDEX FOR QUEUE (0-10).....0

ENTER 'Y' FOR ENABLE DETECTOR

ENTER '5' FOR PHASES ASSIGNED

ENSURE DELAY IS '3'

VEHICLE DETECTOR #55 SETTINGS (+,-,1-64) SETTING: (Y/N) ENABLE DETECTOR.....Y ENABLE LOGGING.....N ENABLE DIAGNOSTICS.....N SPEED TRAP.....N CALL DETECTOR.....Y EXTENSION DETECTOR.....Y MODE 2 STOP BAR.....N SWITCHING DETECTOR.....N DUPLICATING DETECTOR.....N ENABLE FULL TIME DELAY.....N IF FAILED, SET MIN RECALL?.....N IF FAILED, SET MAX1 RECALL?.....N IF FAILED, SET MAX2 RECALL?.....N PHASE# :12345678910111213141516 PHASES ASSIGNED : X SWITCH/DUPLICATE: LOOP SIZE (0-255 FT).....6 SPEED TRAP DISTANCE (0-255 FT).....0 STOP BAR TIME (0-255 SEC).....0 STRETCH (0-25.5 SEC).....0.0 DELAY (0-255 SEC).....3 MAX CALLS/MIN (0-255).....255 MIN CALLS/DIAGNOSTIC PERIOD (0-255).....0 MAX OCCUPANCY (0-100%).....100 EXTENSION DISABLE TIME (0-255 SEC).....0 QUEUE MAX OCCUPANCY TIME (0-255).....0 QUEUE GAP RESET TIME (0-25.5).....0.0 PREEMPTION INDEX FOR QUEUE (0-10).....0

NOTE: DETECTOR IS PROGRAMMED PER THE INPUT FILE CONNECTION AND PROGRAMMING CHART SHOWN ON SHEET 1.

THIS ELECTRICAL DETAIL IS FOR THE SIGNAL DESIGN: 03-097711 DESIGNED: June 2017 SEALED: 9/10/2021 REVISED: N/A

DETECTOR PROGRAMMING COMPLETE

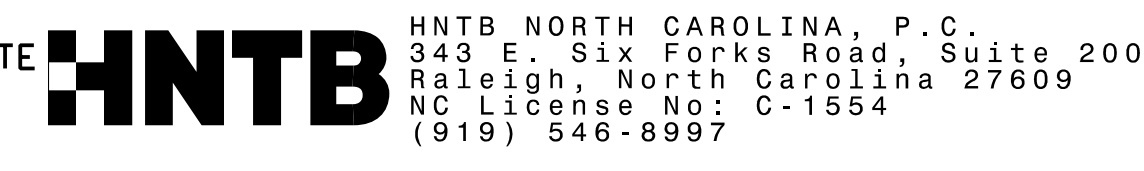

Electrical Detail - Sheet 4 of 5
Signal Upgrade
Temporary Design 1

DOCUMENT NOT CONSIDERED FINAL UNLESS ALL SIGNATURES COMPLETED

Table with project details: NC 211 (Southport-Supply Road) at St. James Drive, Division 03 Brunswick Co. Southport. Includes dates, signatures, and a professional seal for Natasha R. Simmons, Engineer, No. 031464.

ALTERNATE PHASING ACTIVATION DETAIL

TO RUN ALT. PHASING DURING COORDINATION - SELECT ALL PAGE CHANGES (AS SHOWN BELOW) WITHIN COORDINATION PLAN PROGRAMMING.

TO RUN ALT. PHASING DURING FREE RUN - PROGRAM PAGE CHANGES (SHOWN BELOW) IN SEPARATE TIME OF DAY EVENTS. IF PAGE 1 IS USED, NO EVENT PROGRAMMING IS NECESSARY FOR THAT PARTICULAR PAGE.

<u>PHASING</u>	<u>INPUTS PAGE</u>	<u>OVERLAPS PAGE</u>
ACTIVE PAGES REQUIRED TO RUN <u>DEFAULT PHASING</u>	1	1
ACTIVE PAGES REQUIRED TO RUN <u>ALTERNATE PHASING</u>	2	2

NOTE: PAGES NOT SHOWN (i.e. sequence, phase control, etc.) SHOULD REMAIN AS '1', OR AS DEFINED BY TIMING ENGINEER.

IMPORTANT: IF ALT. PHASING IS USED DURING FREE RUN AND COORDINATION, DO NOT OPERATE TIME OF DAY PAGE CHANGE EVENTS CONCURRENTLY WITH COORDINATION PLAN EVENTS IN THE EVENT SCHEDULER. (EX. FREE RUN PAGE CHANGE EVENT SHOULD END BEFORE COORDINATION PLAN EVENT STARTS AND VICE-VERSA).

ALTERNATE PHASING PAGE CHANGE SUMMARY

THE FOLLOWING IS A SUMMARY OF WHAT TAKES PLACE WHEN THESE OVERLAP/INPUT PAGE CHANGES ACTIVATE TO CALL THE "ALTERNATE PHASING":

OVERLAPS PAGE 2: Modifies overlap parent phases for heads 11 and 51 to run protected turns only.

INPUTS PAGE 2: Disables phase 6 call on loop 1A and reduces delay time for phase 1 call on loop 1A to 3 seconds.

Disables phase 2 call on loop 5A and reduces delay time for phase 5 call on loop 5A to 3 seconds.

THIS ELECTRICAL DETAIL IS FOR THE SIGNAL DESIGN: 03-0977T1
DESIGNED: June 2017
SEALED: 9/10/2021
REVISED: N/A

Electrical Detail - Sheet 5 of 5
Signal Upgrade
Temporary Design 1

**DOCUMENT NOT CONSIDERED FINAL
UNLESS ALL SIGNATURES COMPLETED**

HNTB HNTB NORTH CAROLINA, P.C.
343 E. Six Forks Road, Suite 200
Raleigh, North Carolina 27609
NC License No: C-1554
(919) 546-8997

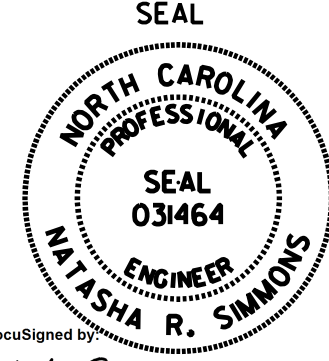
Prepared for:  750 N. Greenfield Pkwy, Corner, NC 27529	NC 211 (Southport-Supply Road) at St. James Drive Division 03 Brunswick Co. Southport PLAN DATE: June 2017 REVIEWED BY: A.D. Klinksiek PREPARED BY: A.H. Thornburg REVIEWED BY: N.R. Simmons	SEAL  NATASHA R. SIMMONS ENGINEER
REVISIONS INIT. DATE		DocuSigned by: Natasha Simmons 9/10/2021 SIGNATURE DATE SIG. INVENTORY NO. 03-0977T1

DEFAULT PHASING DIAGRAM

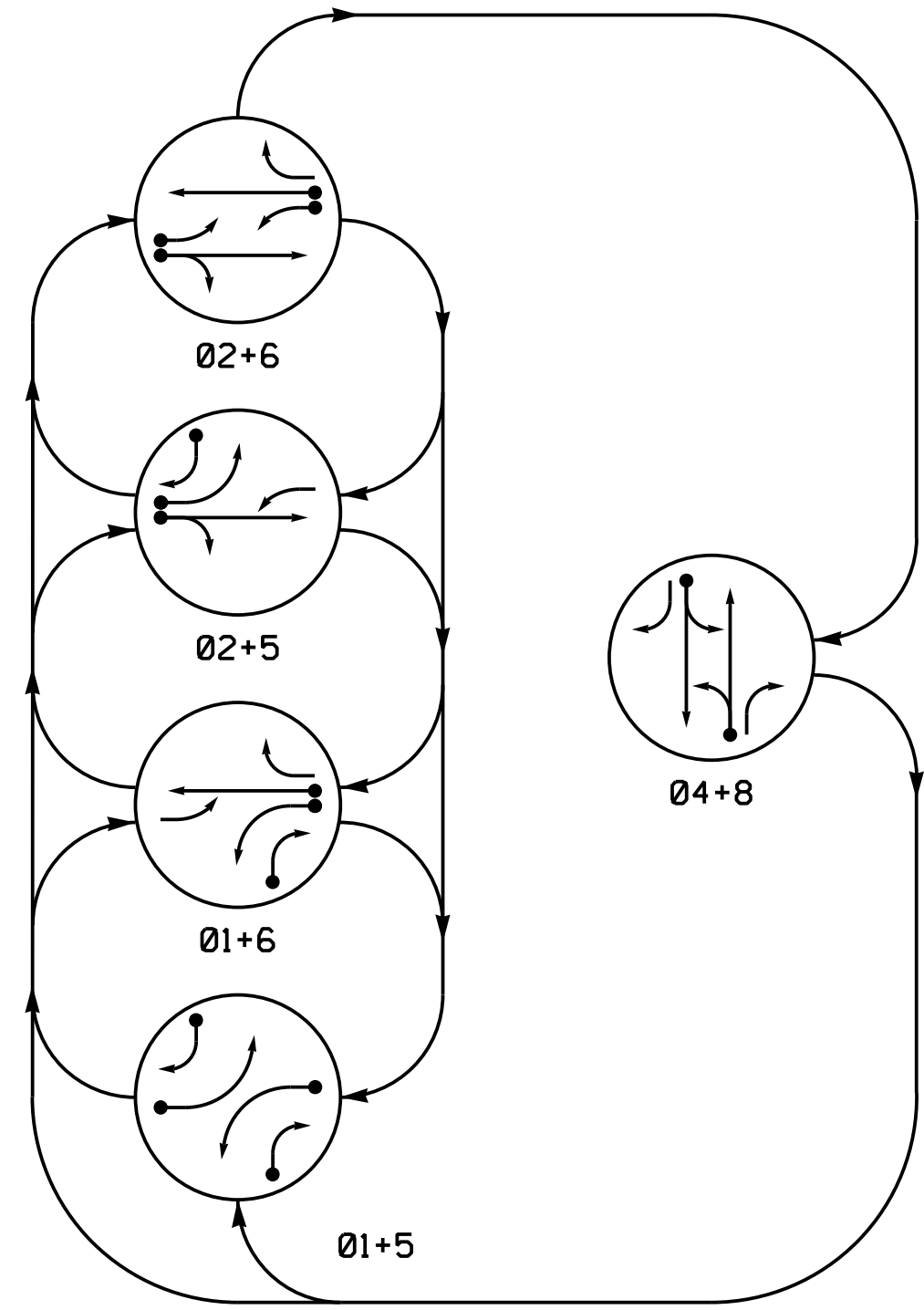

ALTERNATE PHASING DIAGRAM

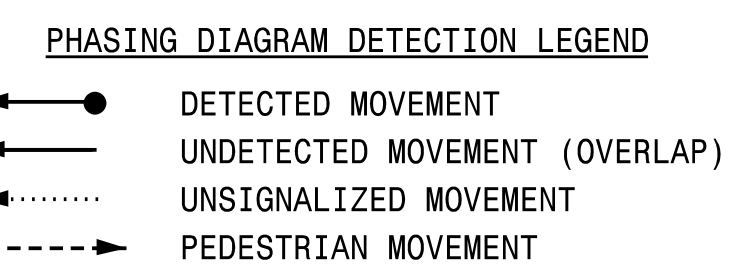
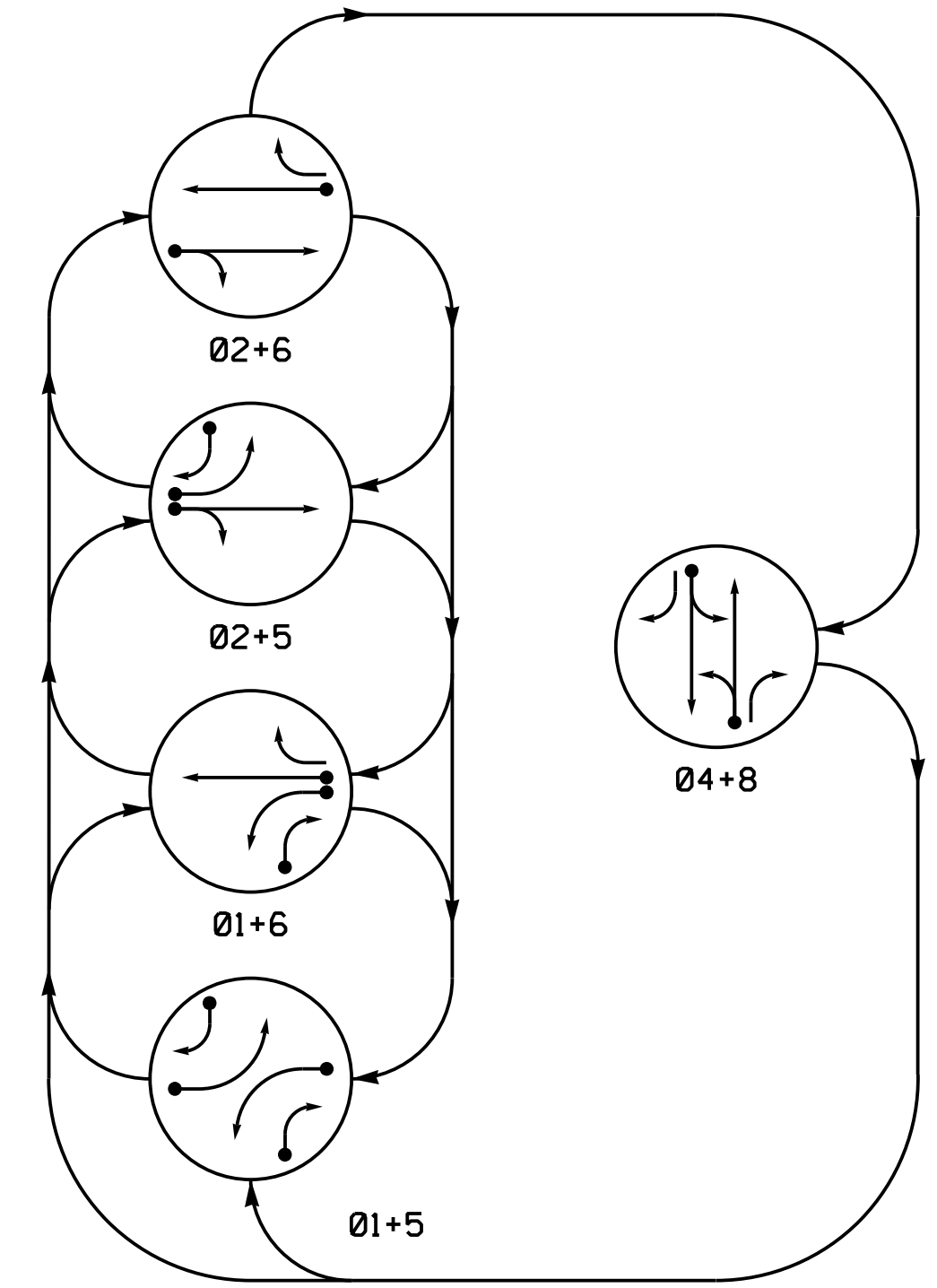

DEFAULT PHASING TABLE OF OPERATION

SIGNAL FACE	PHASE					
	01+5	01+6	02+5	02+6	04+8	F L T
11	—	—	F	F	R	Y
21,22	R	R	G	G	R	Y
41	R	R	R	R	G	R
42	R	R	R	R	G	R
51	—	—	F	F	R	Y
61,62	R	G	R	G	R	Y
81	R	R	R	R	G	R
82	R	R	R	R	G	R

ALTERNATE PHASING TABLE OF OPERATION

SIGNAL FACE	PHASE					
	01+5	01+6	02+5	02+6	04+8	F L T
11	—	—	R	R	R	Y
21,22	R	R	G	G	R	Y
41	R	R	R	R	G	R
42	R	R	R	R	G	R
51	—	—	R	R	R	Y
61,62	R	G	R	G	R	Y
81	R	R	R	R	G	R
82	R	R	R	R	G	R

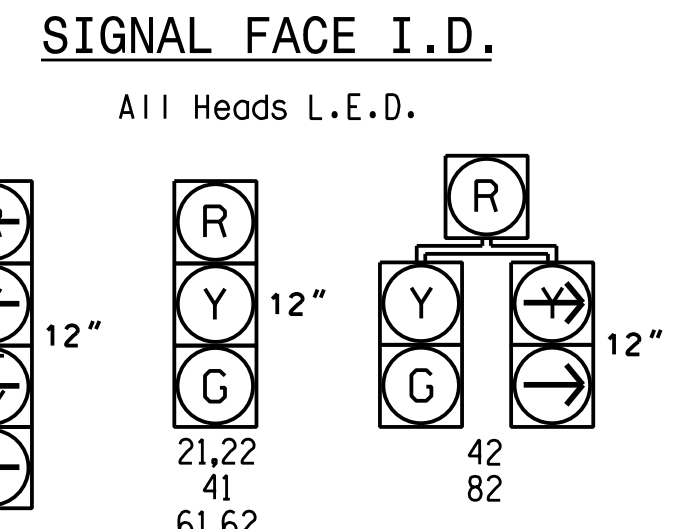

OASIS 2070 LOOP & DETECTOR INSTALLATION CHART

LOOP	SIZE (FT)	DISTANCE FROM STOPBAR (FT)	TURNS	NEW LOOP	DETECTOR PROGRAMMING				SYSTEM LOOP	NEW CARD
					PHASE	CALLING	EXTENSION	FULL TIME DELAY		
1A	6X40	0	*	*	1	Y	Y	-	***15	-
1B	6X40	0	*	*	1	Y	Y	-	3	-
2A	6X6	420	*	*	2	Y	Y	-	-	-
4A	6X40	0	*	*	4	Y	Y	-	-	-
5A	6X40	0	*	*	5	Y	Y	-	***15	-
5B	6X40	0	*	*	5	Y	Y	-	3	-
6A	6X6	420	*	*	6	Y	Y	-	-	-
8A	6X40	0	*	*	8	Y	Y	-	-	-

* Multizone Microwave Detection.
** Disable phase 2 and 6 call for 1A and 5A during alternate phasing operation.
*** Reduce delay to 3 seconds during alternate phasing operation.

5 Phase Fully Actuated Isolated

NOTES

- Refer to "Roadway Standard Drawings NCDOT" dated January 2018 and "Standard Specifications for Roads and Structures" dated January 2018.
- Do not program signal for late night flashing operation unless otherwise directed by the Engineer.
- Phase 1 and/or phase 5 may be lagged.
- Reposition existing signal heads numbered 11,21,22,41,51,61 and 62.
- Set all detector units to presence mode.
- The Division Traffic Engineer will determine the hours of use for each phasing plan.
- Incorporate Microwave Detection system for vehicle detection.
- Provide the Engineer with the Manufacturer's approved Microwave Detection locations and mounting heights to obtain detection zones as shown.

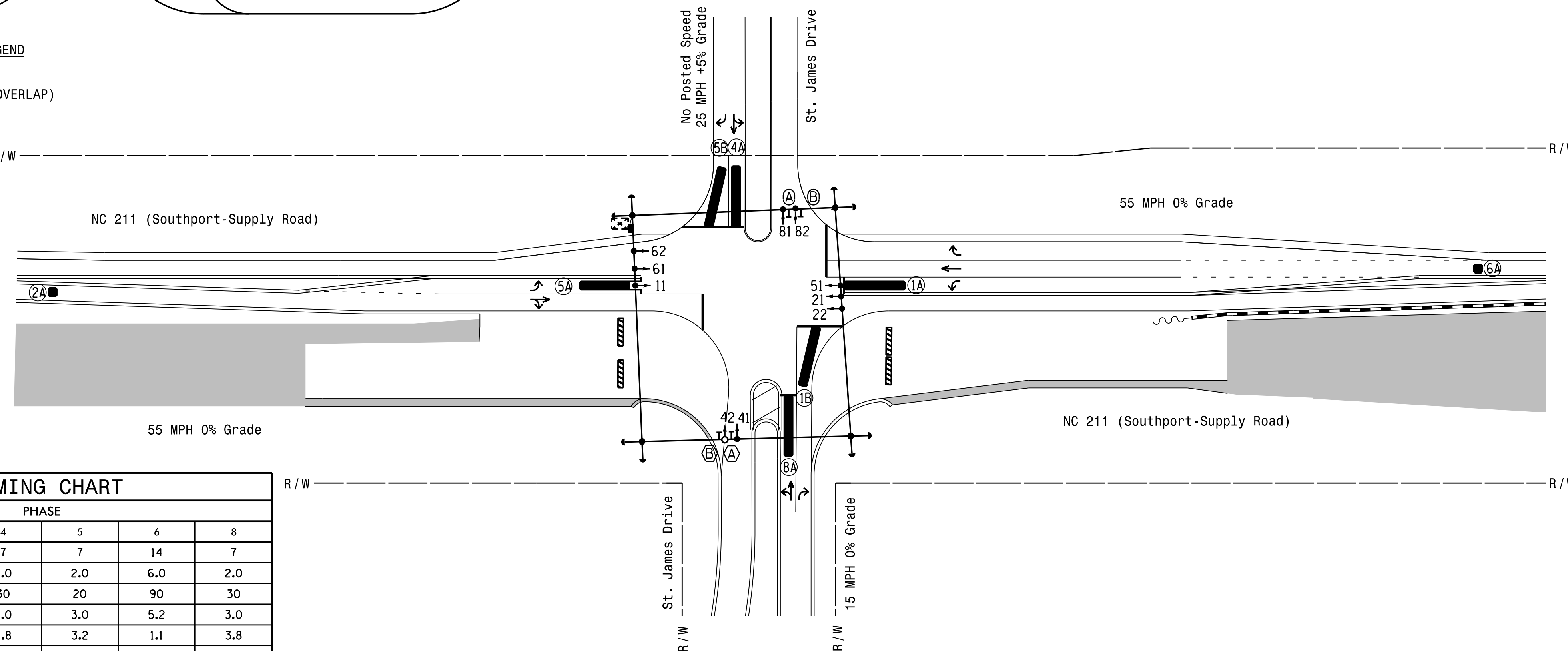

OASIS 2070 TIMING CHART

FEATURE	PHASE					
	1	2	4	5	6	8
Min Green 1 *	7	14	7	7	14	7
Extension 1 *	2.0	6.0	2.0	2.0	6.0	2.0
Max Green 1 *	20	90	30	20	90	30
Yellow Clearance	3.0	5.2	3.0	3.0	5.2	3.0
Red Clearance	2.3	1.1	2.8	3.2	1.1	3.8
Red Revert	2.0	2.0	2.0	2.0	2.0	2.0
Walk 1 *	-	-	-	-	-	-
Don't Walk 1	-	-	-	-	-	-
Seconds Per Actuation *	-	2.5	-	-	2.5	-
Max Variable Initial *	-	46	-	-	46	-
Time Before Reduction *	-	15	-	-	15	-
Time To Reduce *	-	30	-	-	30	-
Minimum Gap	-	3.4	-	-	3.4	-
Recall Mode	-	MIN RECALL	-	-	MIN RECALL	-
Vehicle Call Memory	-	YELLOW	-	-	YELLOW	-
Dual Entry	-	-	ON	-	-	ON
Simultaneous Gap	ON	ON	ON	ON	ON	ON

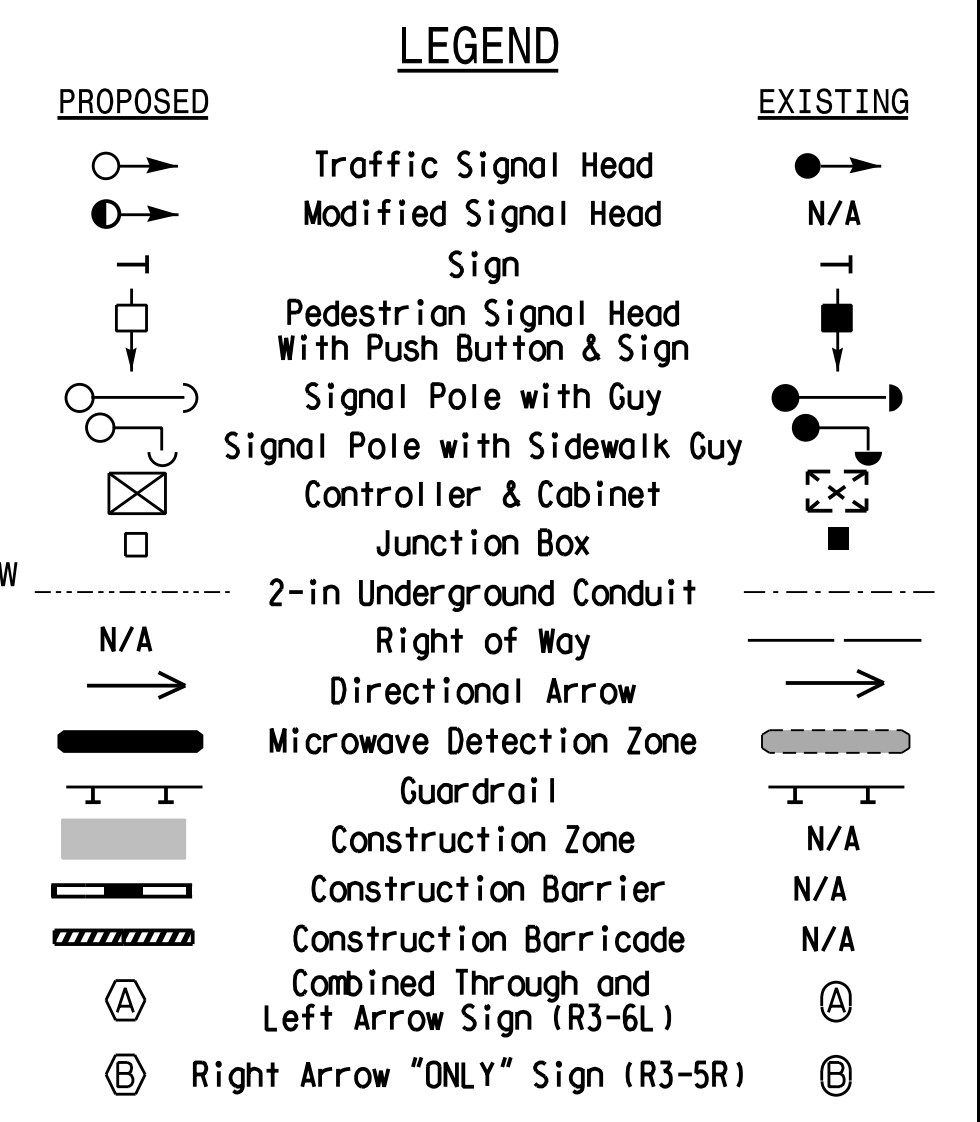

Signal Upgrade
Temporary Design 2
Construction Phase 2

DOCUMENT NOT CONSIDERED FINAL UNLESS ALL SIGNATURES COMPLETED

Prepared for: **TRANSPORTATION MOBILITY AND SAFETY DIVISION**
343 E. Six Forks Road, Suite 200
Raleigh, North Carolina 27609
NC License No: C-1554
(919) 546-8997

HNTB

750 N. Greenfield Pkwy, Corner, NC 27526

NC 211 (Southport-Supply Road)
at
St. James Drive

Division 03 Brunswick Co. Southport
PLAN DATE: June 2017 REVIEWED BY: A.D. Klinksiek
PREPARED BY: A.H. Thornburg REVIEWED BY: N.R. Simmons

SEAL
NORTH CAROLINA PROFESSIONAL ENGINEER
SEAL 031464
NATASHA R. SIMMONS

9/10/2021
DATE

SIGNATURE

SIG. INVENTORY NO. 03-097772

* These values may be field adjusted. Do not adjust Min Green and Extension times for phases 2 and 6 lower than what is shown. Min Green for all other phases should not be lower than 4 seconds.

EDI MODEL 2018ECL-NC CONFLICT MONITOR PROGRAMMING DETAIL

(remove jumpers and set switches as shown)

REMOVE DIODE JUMPERS 1-5, 1-6, 1-9, 1-11, 2-5, 2-6, 2-9, 2-11, 4-8, 5-9, 5-11, 6-9, 6-11, and 9-11.

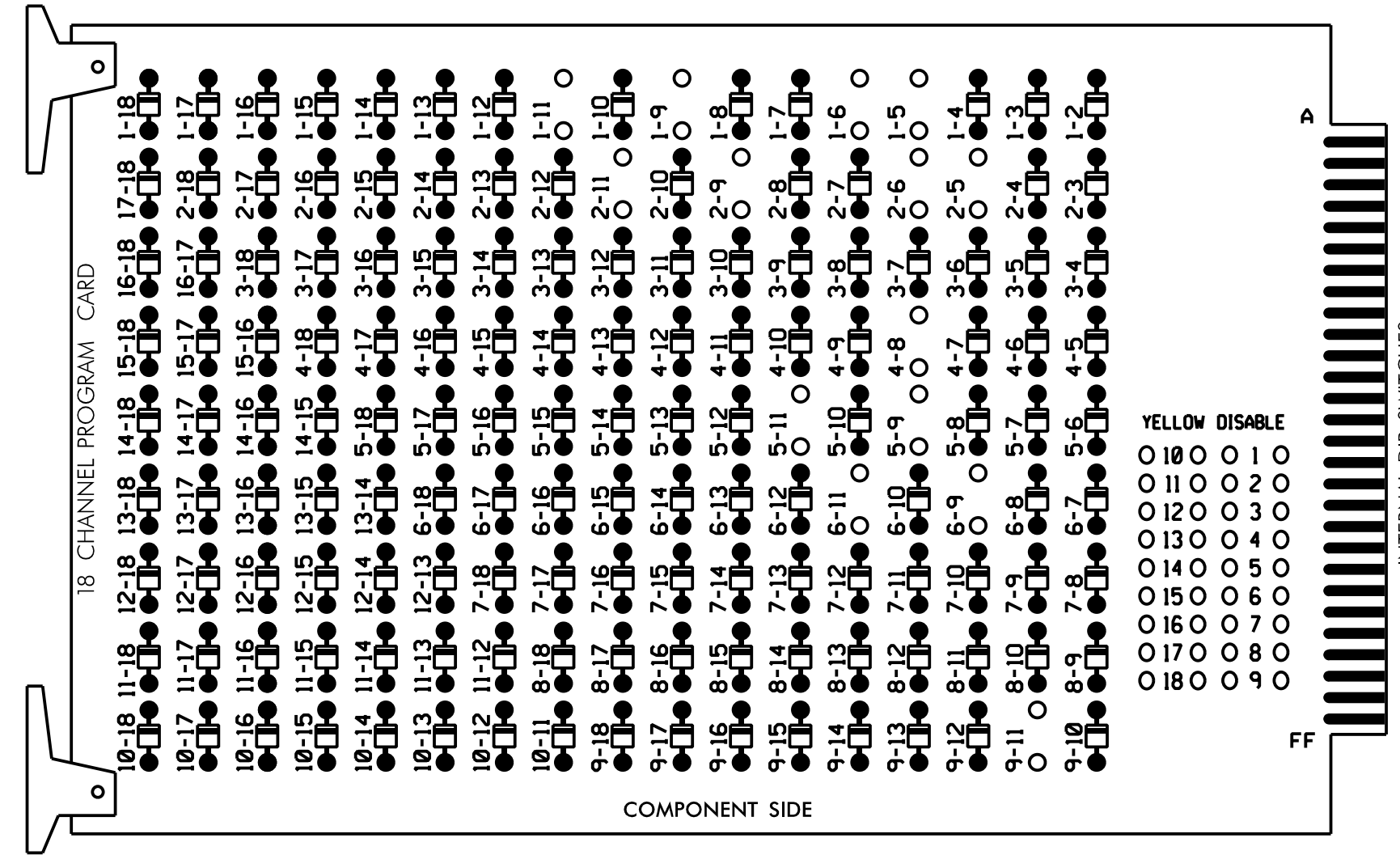

REMOVE JUMPERS AS SHOWN

NOTES:

1. Card is provided with all diode jumpers in place. Removal of any jumper allows its channels to run concurrently.
2. Ensure jumpers SEL2-SEL5 and SEL9 are present on the monitor board.
3. Ensure that Red Enable is active at all times during normal operation.
4. Connect serial cable from conflict monitor to comm. port 1 of 2070 controller. Ensure conflict monitor communicates with 2070.

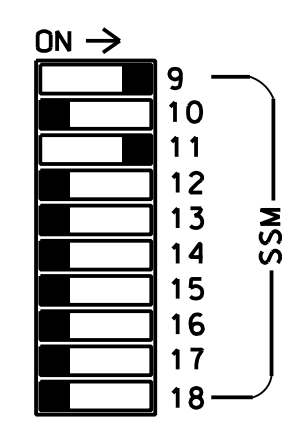
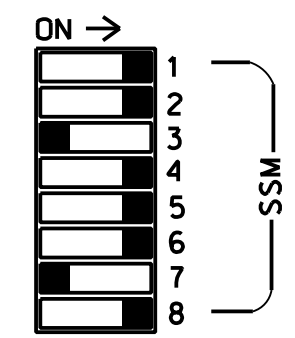
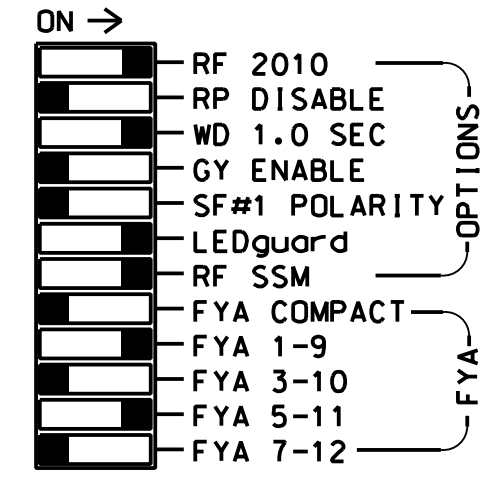
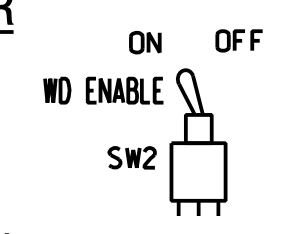

■ = DENOTES POSITION OF SWITCH

NOTES

1. To prevent "flash-conflict" problems, insert red flash program blocks for all unused vehicle load switches in the output file. The installer shall verify that signal heads flash in accordance with the Signal Plans.
2. Program phases 4 and 8 for Dual Entry.
3. Enable Simultaneous Gap-Out for all Phases.
4. Program phases 2 and 6 for Variable Initial and Gap Reduction.
5. Program phases 2 and 6 for Startup In Green.
6. Program phases 2 and 6 for Yellow Flash, and overlap 1 as Wag Overlaps.
7. If this signal will be managed by an ATMS software, enable controller and detector logging for all detectors used at this location.

EQUIPMENT INFORMATION

CONTROLLER.....2070E
 CABINET.....332 W/AUX
 SOFTWARE.....ECONOLITE OASIS
 CABINET MOUNT.....BASE
 OUTPUT FILE POSITIONS...18 WITH AUX. OUTPUT FILE
 LOAD SWITCHES USED.....S1,S2,S5,S7,S8,S11,AUX S1,
 AUX S4
 PHASES USED.....1,2,4,5,6,8
 OVERLAP "A".....1+2
 OVERLAP "B".....NOT USED
 OVERLAP "C".....5+6
 OVERLAP "D".....NOT USED

SIGNAL HEAD HOOK-UP CHART

LOAD SWITCH NO.	S1	S2	S3	S4	S5	S6	S7	S8	S9	S10	S11	S12	AUX S1	AUX S2	AUX S3	AUX S4	AUX S5	AUX S6	
CMU CHANNEL NO.	1	2	13	3	4	14	5	6	15	7	8	16	9	10	17	11	12	18	
PHASE	1	2	2 PED	3	4	4 PED	5	6	6 PED	7	8	8 PED	OLA	OLB	SPARE	OLC	OLD	SPARE	
SIGNAL HEAD NO.	11★	82	21,22	NU	NU	41,42	NU	42	51★	61,62	NU	NU	81,82	NU	11★	NU	NU	51★	NU
RED	*	128			101		*	134		107									
YELLOW		129			102			135		108									
GREEN		130			103			136		109									
RED ARROW													A121					A114	
YELLOW ARROW	126							132					A122					A115	
FLASHING YELLOW ARROW													A123					A116	
GREEN ARROW	127	127					133	133											

NU = Not Used

* Denotes install load resistor. See load resistor installation detail this sheet.

★ See pictorial of head wiring in detail this sheet.

INPUT FILE POSITION LAYOUT

(front view)

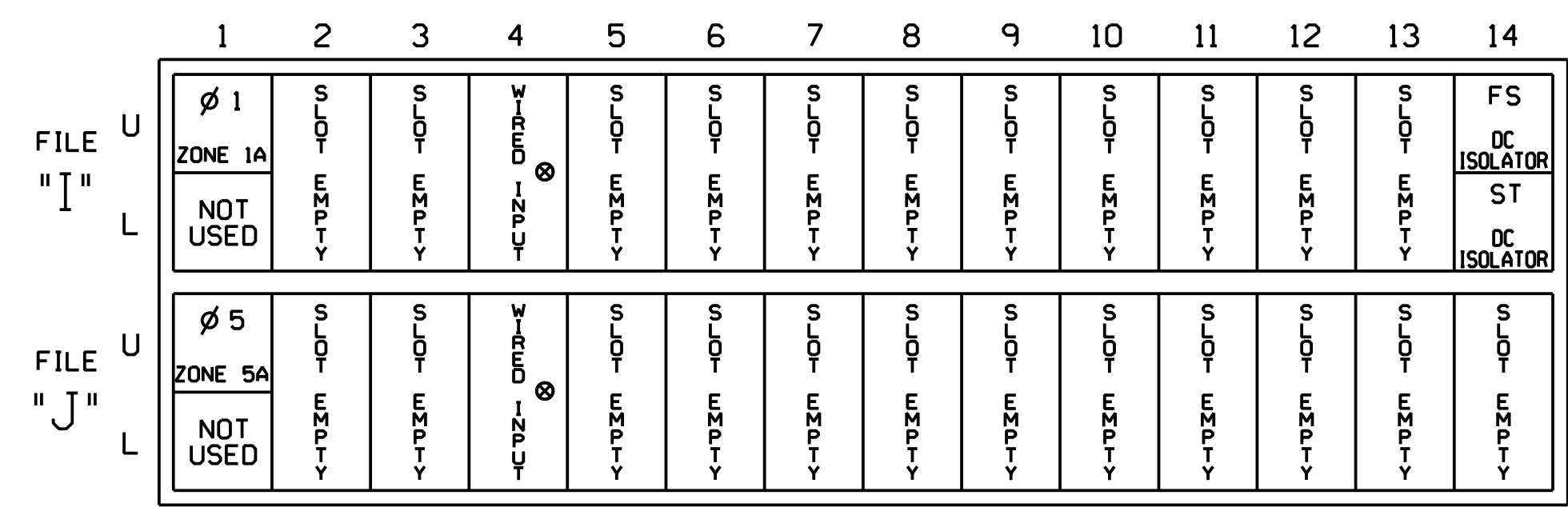

EX.: 1A, 2A, ETC. = LOOP NO.'S

FS = FLASH SENSE
 ST = STOP TIME

⊗ Wired Input - Do not populate slot with detector card

INPUT FILE CONNECTION & PROGRAMMING CHART

LOOP NO.	LOOP TERMINAL	INPUT FILE POS.	PIN NO.	INPUT ASSIGNMENT NO.	DETECTOR NO.	NEMA PHASE	CALL	EXTEND	FULL TIME DELAY	STRETCH TIME	DELAY TIME
ZONE 1A ¹	★★	I1U	56	18	1	1	Y	Y			15
	-	J4U	48	10★	26	6	Y	Y	Y		3
ZONE 5A ²	★★	J1U	55	17	5	5	Y	Y			15
	-	I4U	47	9★	22	2	Y	Y	Y		3
			J1U	55	17★	5	Y	Y			3

- 1 Add jumper from I1-W to J4-W, on rear of input file.
 - 2 Add jumper from J1-W to I4-W, on rear of input file.
- * See Input Page Assignment programming details on sheets 3 and 4.
 ** Multizone Microwave Detector Zone. See Special Detector Note.

INPUT FILE POSITION LEGEND: J2L

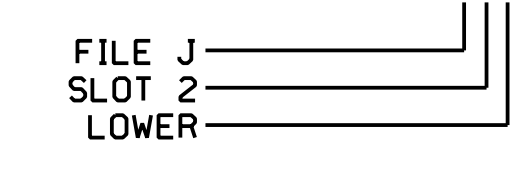

SPECIAL DETECTOR NOTE

Install a microwave detection system for vehicle detection. Perform installation according to manufacturer's directions and NCDOT engineer-approved mounting locations to accomplish the detection schemes shown on the Signal Design Plans.

For loops 1A and 5A detector card placement and slots reserved for wired inputs are typical for a NCDOT installation. Inputs associated with these slots are compatible with the time of day instructions located on sheets 3, 4, and 5 of this electrical detail.

FYA SIGNAL WIRING DETAIL

(wire signal heads as shown)

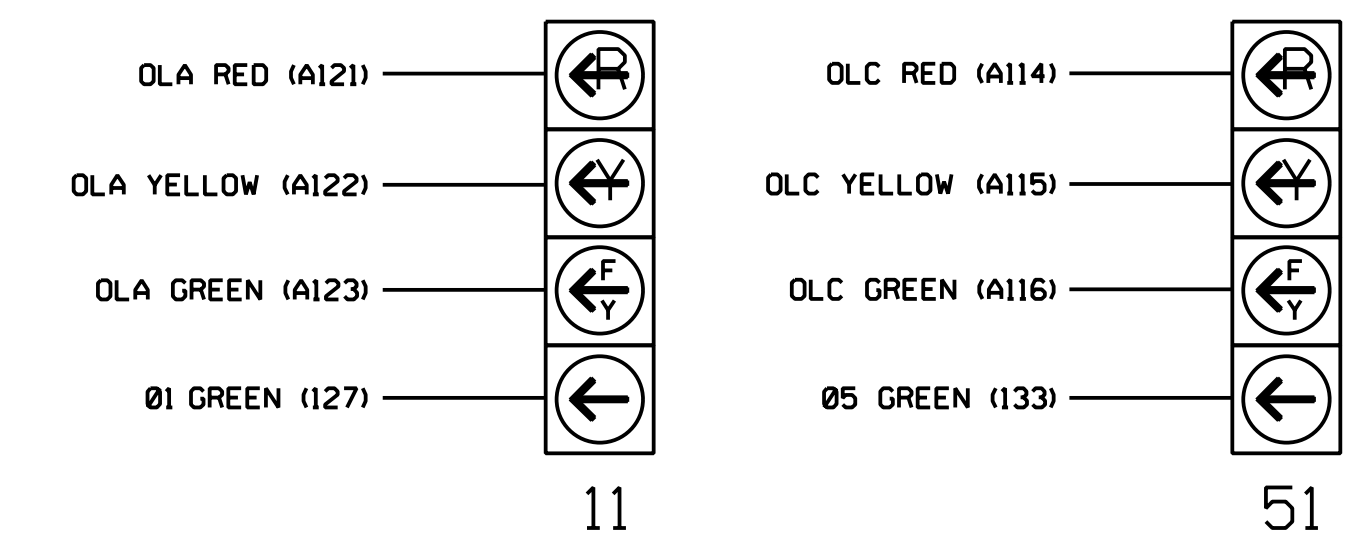

NOTE

The sequence display for signal heads 11 and 51 requires special logic programming. See sheet 2 for programming instructions.

LOAD RESISTOR INSTALLATION DETAIL

(install resistors as shown)

VALUE (ohms)	WATTAGE
1.5K - 1.9K	25W (min)
2.0K - 3.0K	10W (min)

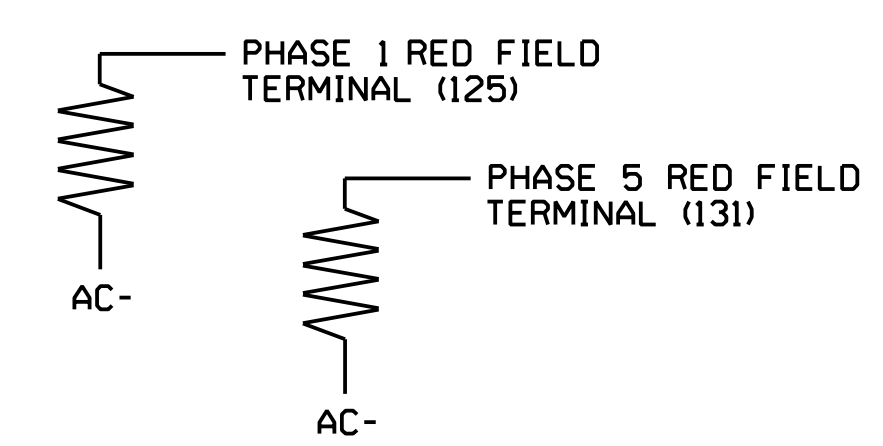

Electrical Detail - Sheet 1 of 5
 Signal Upgrade
 Temporary Design 2

DOCUMENT NOT CONSIDERED FINAL UNLESS ALL SIGNATURES COMPLETED

Electrical and Programming Details for: **NC 211 (Southport-Supply Road) at St. James Drive**

Division 03 Brunswick Co. Southport

PLAN DATE: June 2017 REVIEWED BY: A.D. Klinksiek

PREPARED BY: A.H. Thornburg REVIEWED BY: N.R. Simmons

750 N. Greenfield Pkwy, Corner, NC 27529

Prepared for: **North Carolina Department of Transportation**

Division 03 Brunswick Co. Southport

PLAN DATE: June 2017 REVIEWED BY: A.D. Klinksiek

PREPARED BY: A.H. Thornburg REVIEWED BY: N.R. Simmons

750 N. Greenfield Pkwy, Corner, NC 27529

Seal of North Carolina Professional Engineer: **W. TASHA R. SIMMONS**, No. 031464

Signature: **Netasha Simmons**, 9/10/2021

Signature: _____, _____

SIG. INVENTORY NO. 03-0977T2

LOGICAL I/O PROCESSOR PROGRAMMING DETAIL TO PRODUCE SPECIAL FYA-PPLT SIGNAL SEQUENCE

(program controller as shown below)

- FROM MAIN MENU PRESS '2' (PHASE CONTROL), THEN '1' (PHASE CONTROL FUNCTIONS). SCROLL TO THE BOTTOM OF THE MENU AND ENABLE ACT LOGIC COMMANDS 1, 2, 3, 4, 5, AND 6.
- FROM MAIN MENU PRESS '6' (OUTPUTS), THEN '3' (LOGICAL I/O PROCESSOR).

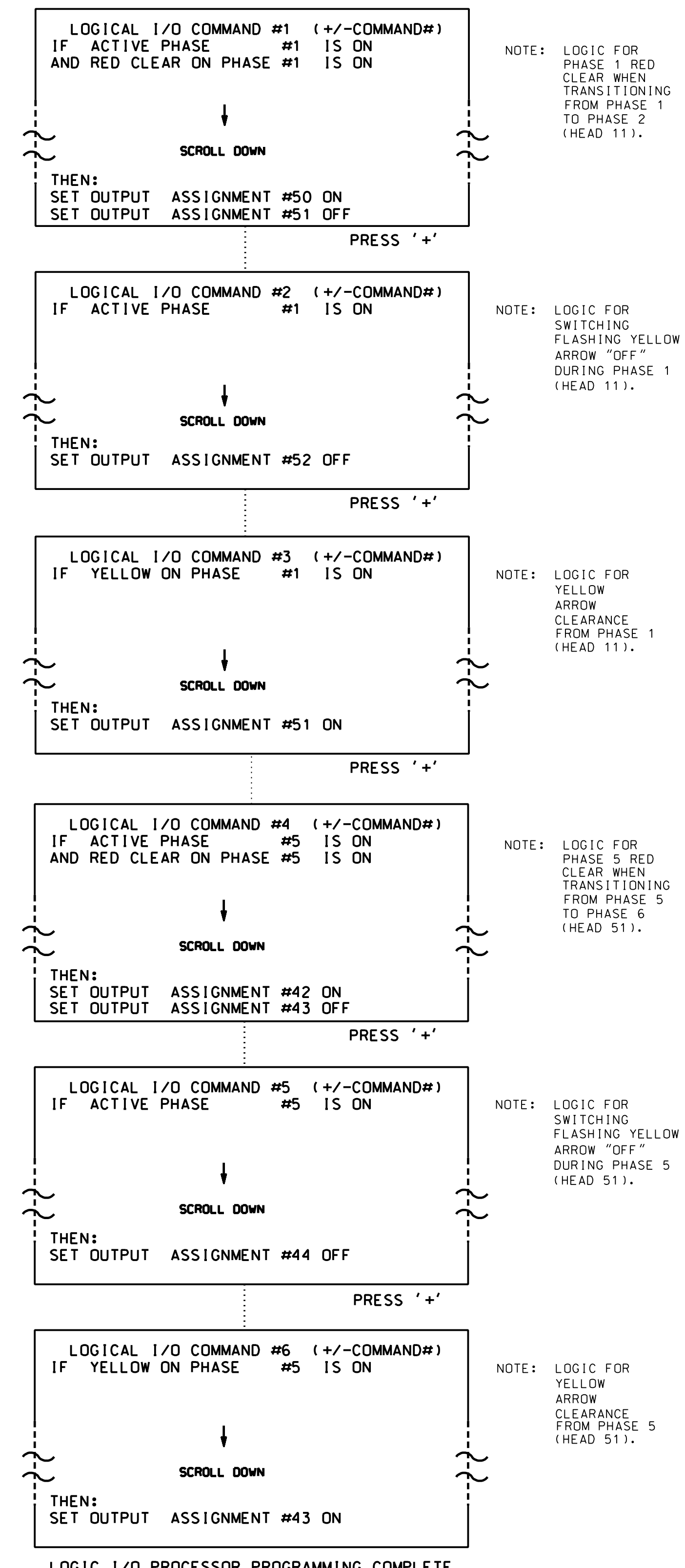

OUTPUT REFERENCE SCHEDULE	
USE TO INTERPRET LOGIC PROCESSOR	
OUTPUT 42	= Overlap C Red
OUTPUT 43	= Overlap C Yellow
OUTPUT 44	= Overlap C Green
OUTPUT 50	= Overlap A Red
OUTPUT 51	= Overlap A Yellow
OUTPUT 52	= Overlap A Green

OVERLAP PROGRAMMING DETAIL FOR DEFAULT PHASING

(program controller as shown below)

FROM MAIN MENU PRESS '8' (OVERLAPS), THEN '1' (VEHICLE OVERLAP SETTINGS).

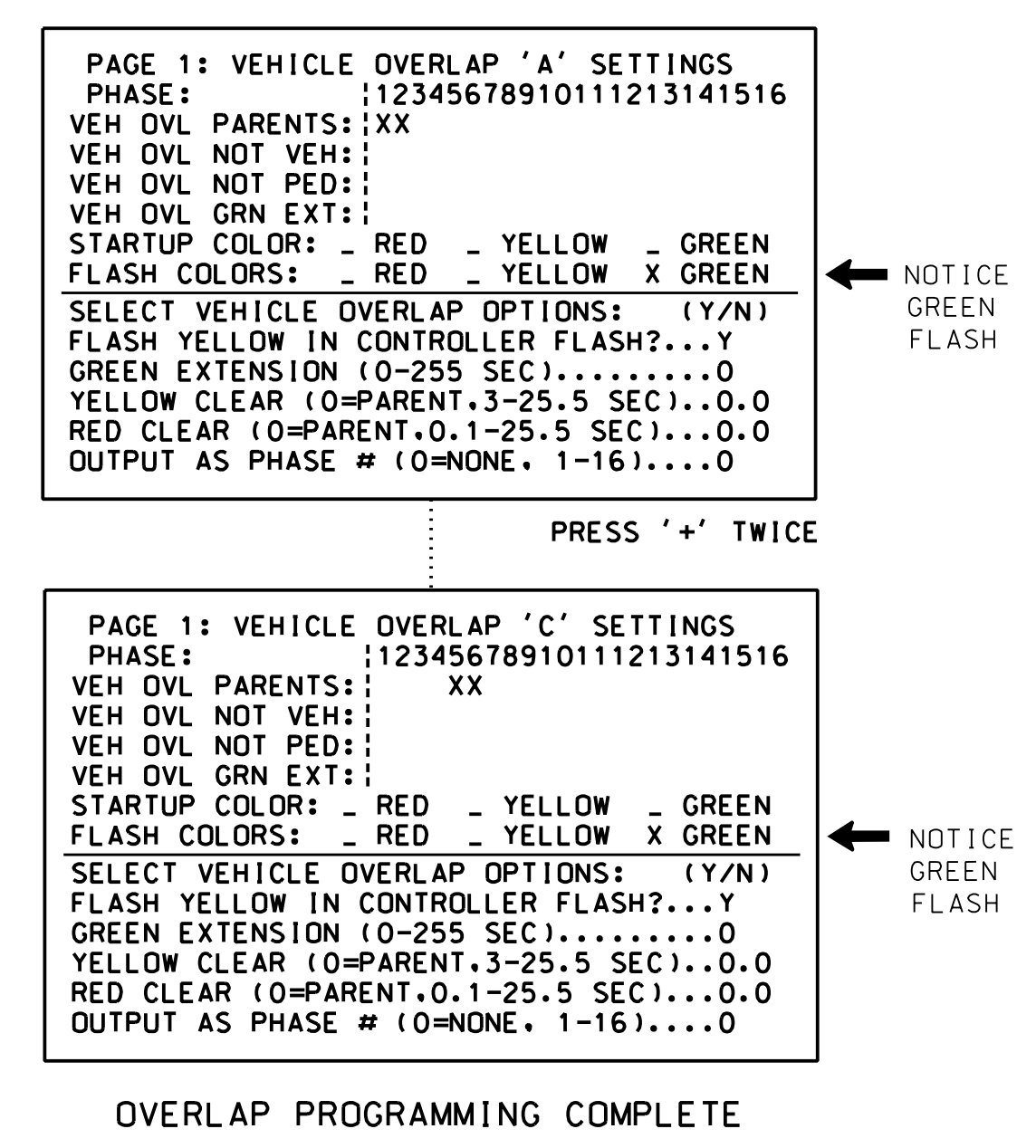

OVERLAP PROGRAMMING DETAIL FOR ALTERNATE PHASING

(program controller as shown below)

FROM MAIN MENU PRESS '8' (OVERLAPS), THEN '1' (VEHICLE OVERLAP SETTINGS). PRESS 'NEXT' TO ADVANCE TO PAGE 2.

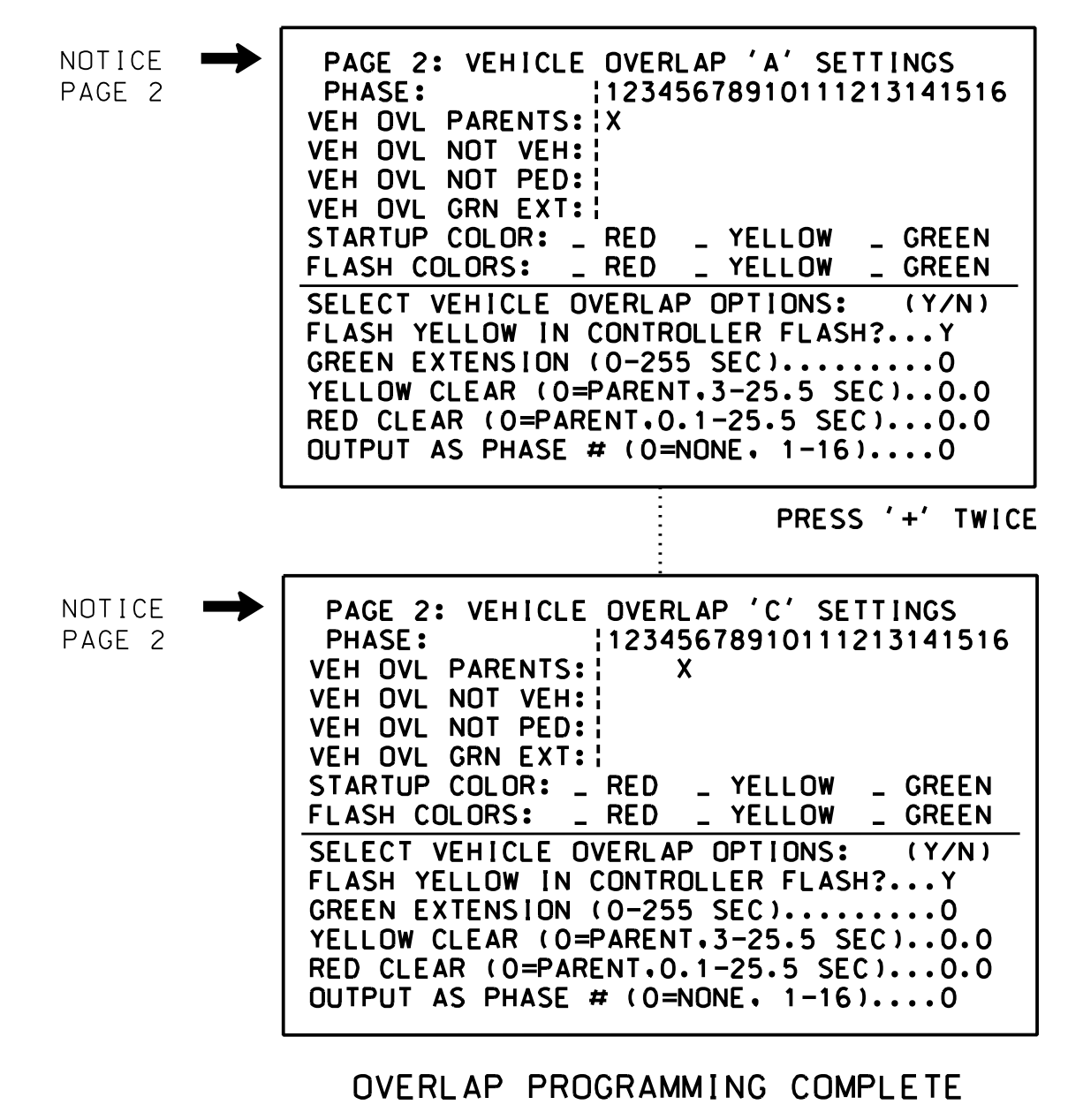

THIS ELECTRICAL DETAIL IS FOR
THE SIGNAL DESIGN: 03-0977T2
DESIGNED: June 2017
SEALED: 9/10/2021
REVISED: N/A

Electrical Detail - Sheet 2 of 5
Signal Upgrade
Temporary Design 2

**DOCUMENT NOT CONSIDERED FINAL
UNLESS ALL SIGNATURES COMPLETED**

	Prepared for: 		NC 211 (Southport-Supply Road) at St. James Drive Division 03 Brunswick Co. Southport	SEAL
	Prepared by: A.H. Thornburg Reviewed by: N.R. Simmons			
HNTB NORTH CAROLINA, P.C. 343 E. Six Forks Road, Suite 200 Raleigh, North Carolina 27609 NC License No: C-1554 (919) 546-8997		750 N. Greenfield Pkwy, Corner, NC 27529		

INPUT PAGE 2 ASSIGNMENT PROGRAMMING DETAIL FOR ALTERNATE PHASING - LOOP 1A

(program controller as shown below)

- NOTES: 1. THIS PROGRAMMING APPLIES FOR INPUT PAGE 2 ONLY. INPUT PAGE 1 WILL USE STANDARD DEFAULT SETTINGS. THIS PROGRAMMING IS NECESSARY FOR PROPER DETECTOR OPERATION DURING ALTERNATE PHASING OPERATION. 2. THE FIRST TASK THIS PROGRAMMING ACCOMPLISHES IS THE DISABLING OF INPUT #10 (DETECTOR 26) SO THAT A VEHICLE CALL WILL NOT BE PLACED TO PHASE 6 DURING ALTERNATE PHASING OPERATION. THE SECOND TASK THIS PROGRAMMING ACCOMPLISHES IS THAT IT REASSIGNS DETECTOR 51 TO INPUT #18 SO THAT THE DELAY ON LOOP 1A CAN BE REDUCED FROM 15 SECONDS TO 3 SECONDS.

FROM MAIN MENU PRESS '5' (INPUTS), THEN PRESS 'NEXT' TO GET TO INPUT PAGE '2'. PRESS THE '+' KEY UNTIL INPUT 10 IS REACHED.

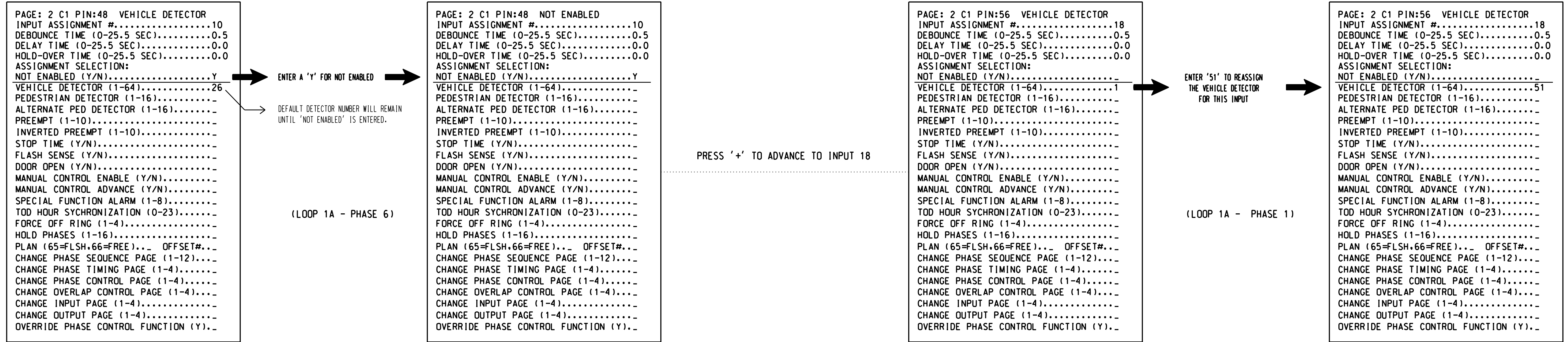

PROGRAMMING COMPLETE

SPECIAL DETECTOR PROGRAMMING DETAIL - LOOP 1A (ALT.)

(program controller as shown below)

FROM MAIN MENU PRESS '7' (DETECTORS), THEN PRESS '1' FOR VEHICLE DETECTORS. PRESS THE '-' KEY TO GET TO VEHICLE DETECTOR #51.

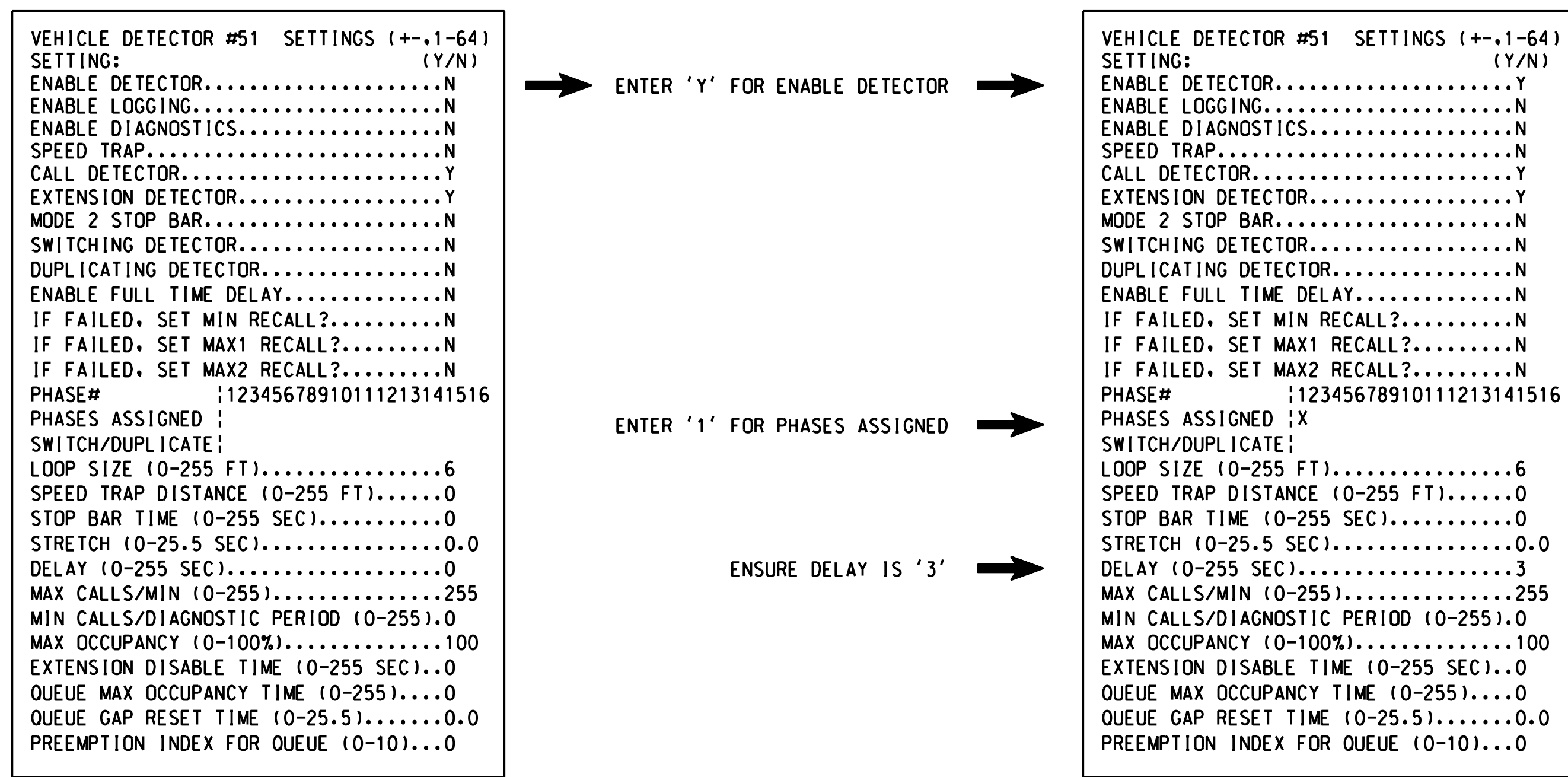

DETECTOR PROGRAMMING COMPLETE

NOTE: DETECTOR IS PROGRAMMED PER THE INPUT FILE CONNECTION AND PROGRAMMING CHART SHOWN ON SHEET 1.

THIS ELECTRICAL DETAIL IS FOR THE SIGNAL DESIGN: 03-0977T2 DESIGNED: June 2017 SEALED: 9/10/2021 REVISED: N/A

Electrical Detail - Sheet 3 of 5 Signal Upgrade Temporary Design 2

DOCUMENT NOT CONSIDERED FINAL UNLESS ALL SIGNATURES COMPLETED

Project information box containing: Prepared for: NC 211 (Southport-Supply Road) at St. James Drive; Division 03 Brunswick Co. Southport; PLAN DATE: June 2017; REVIEWED BY: A.D. Klinksiek; PREPARED BY: A.H. Thornburg; REVIEWED BY: N.R. Simmons; HNTB logo; North Carolina Professional Engineer Seal for Natasha R. Simmons; and a table for Revisions.

HNTB HNTB NORTH CAROLINA, P.C. 343 E. Six Forks Road, Suite 200 Raleigh, North Carolina 27609 NC license No: C-1554 (919) 546-8997

INPUT PAGE 2 ASSIGNMENT PROGRAMMING DETAIL FOR ALTERNATE PHASING - LOOP 5A

(program controller as shown below)

- NOTES: 1. THIS PROGRAMMING APPLIES FOR INPUT PAGE 2 ONLY. INPUT PAGE 1 WILL USE STANDARD DEFAULT SETTINGS. THIS PROGRAMMING IS NECESSARY FOR PROPER DETECTOR OPERATION DURING ALTERNATE PHASING OPERATION. 2. THE FIRST TASK THIS PROGRAMMING ACCOMPLISHES IS THE DISABLING OF INPUT #9 (DETECTOR 22) SO THAT A VEHICLE CALL WILL NOT BE PLACED TO PHASE 2 DURING ALTERNATE PHASING OPERATION. THE SECOND TASK THIS PROGRAMMING ACCOMPLISHES IS THAT IT REASSIGNS DETECTOR 55 TO INPUT #17 SO THAT THE DELAY ON LOOP 5A CAN BE REDUCED FROM 15 SECONDS TO 3 SECONDS.

FROM MAIN MENU PRESS '5' (INPUTS), THEN PRESS 'NEXT' TO GET TO INPUT PAGE '2'. PRESS THE '+' KEY UNTIL INPUT 9 IS REACHED.

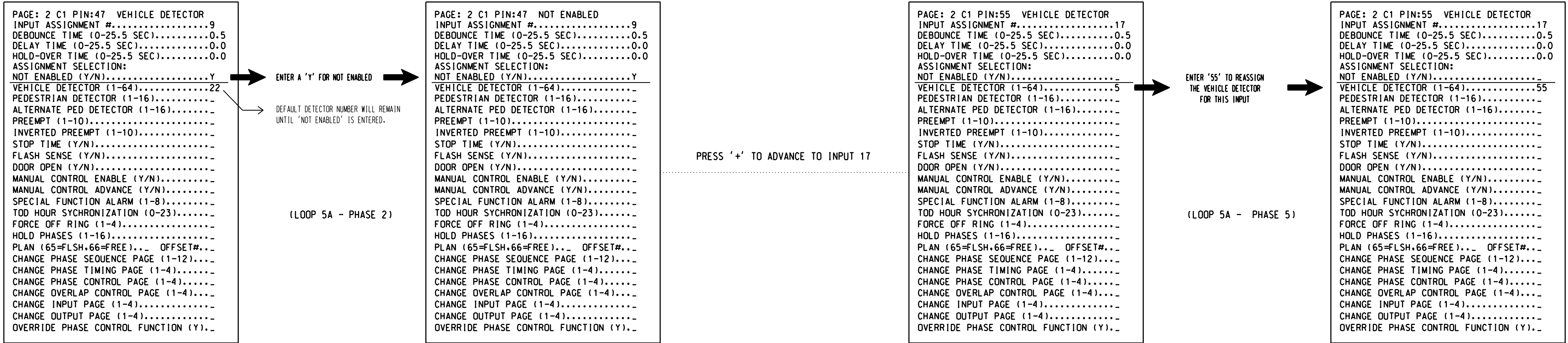

SPECIAL DETECTOR PROGRAMMING DETAIL - LOOP 5A (ALT.)

(program controller as shown below)

FROM MAIN MENU PRESS '7' (DETECTORS), THEN PRESS '1' FOR VEHICLE DETECTORS. PRESS THE '-' KEY TO GET TO VEHICLE DETECTOR #55.

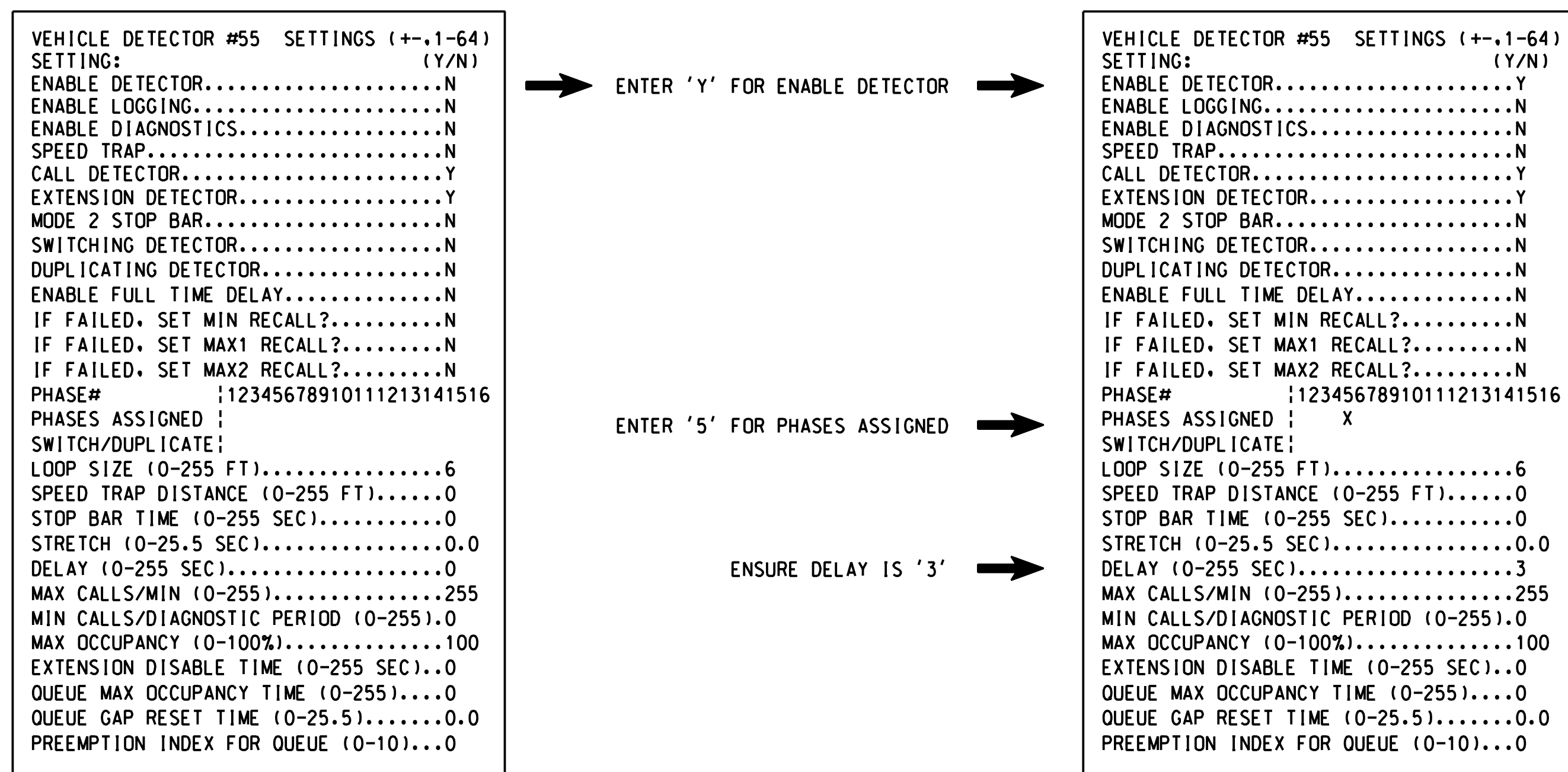

NOTE: DETECTOR IS PROGRAMMED PER THE INPUT FILE CONNECTION AND PROGRAMMING CHART SHOWN ON SHEET 1.

THIS ELECTRICAL DETAIL IS FOR THE SIGNAL DESIGN: 03-0977T2
DESIGNED: June 2017
SEALED: 9/10/2021
REVISED: N/A

Electrical Detail - Sheet 4 of 5
Signal Upgrade
Temporary Design 2

DOCUMENT NOT CONSIDERED FINAL UNLESS ALL SIGNATURES COMPLETED

Table with project details: NC 211 (Southport-Supply Road) at St. James Drive, Brunswick Co., Southport. Includes fields for Plan Date, Prepared By, Reviewed By, and a signature block for Natasha Simmons dated 9/10/2021.

ALTERNATE PHASING ACTIVATION DETAIL

TO RUN ALT. PHASING DURING COORDINATION - SELECT ALL PAGE CHANGES (AS SHOWN BELOW) WITHIN COORDINATION PLAN PROGRAMMING.

TO RUN ALT. PHASING DURING FREE RUN - PROGRAM PAGE CHANGES (SHOWN BELOW) IN SEPARATE TIME OF DAY EVENTS. IF PAGE 1 IS USED, NO EVENT PROGRAMMING IS NECESSARY FOR THAT PARTICULAR PAGE.

<u>PHASING</u>	<u>INPUTS PAGE</u>	<u>OVERLAPS PAGE</u>
ACTIVE PAGES REQUIRED TO RUN <u>DEFAULT PHASING</u>	1	1
ACTIVE PAGES REQUIRED TO RUN <u>ALTERNATE PHASING</u>	2	2

NOTE: PAGES NOT SHOWN (i.e. sequence, phase control, etc.) SHOULD REMAIN AS '1', OR AS DEFINED BY TIMING ENGINEER.

IMPORTANT: IF ALT. PHASING IS USED DURING FREE RUN AND COORDINATION, DO NOT OPERATE TIME OF DAY PAGE CHANGE EVENTS CONCURRENTLY WITH COORDINATION PLAN EVENTS IN THE EVENT SCHEDULER. (EX. FREE RUN PAGE CHANGE EVENT SHOULD END BEFORE COORDINATION PLAN EVENT STARTS AND VICE-VERSA).

ALTERNATE PHASING PAGE CHANGE SUMMARY

THE FOLLOWING IS A SUMMARY OF WHAT TAKES PLACE WHEN THESE OVERLAP/INPUT PAGE CHANGES ACTIVATE TO CALL THE "ALTERNATE PHASING":

OVERLAPS PAGE 2: Modifies overlap parent phases for heads 11 and 51 to run protected turns only.

INPUTS PAGE 2: Disables phase 6 call on loop 1A and reduces delay time for phase 1 call on loop 1A to 3 seconds.

Disables phase 2 call on loop 5A and reduces delay time for phase 5 call on loop 5A to 3 seconds.

THIS ELECTRICAL DETAIL IS FOR THE SIGNAL DESIGN: 03-0977T2
 DESIGNED: June 2017
 SEALED: 9/10/2021
 REVISED: N/A

Electrical Detail - Sheet 5 of 5
Signal Upgrade
Temporary Design 2

DOCUMENT NOT CONSIDERED FINAL UNLESS ALL SIGNATURES COMPLETED

HNTB HNTB NORTH CAROLINA, P.C.
 343 E. Six Forks Road, Suite 200
 Raleigh, North Carolina 27609
 NC License No: C-1554
 (919) 546-8997

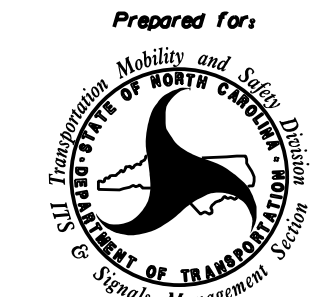
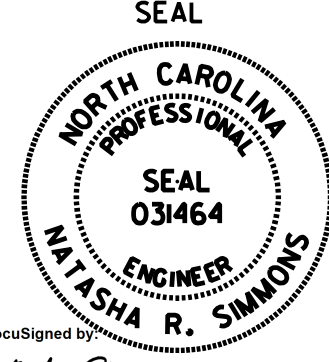
 Prepared for: Department of Transportation Division of Signal Management	NC 211 (Southport-Supply Road) at St. James Drive Division 03 Brunswick Co. Southport	 SEAL 031464 NATASHA R. SIMMONS
	PLAN DATE: June 2017 REVIEWED BY: A.D. Klinksiek PREPARED BY: A.H. Thornburg REVIEWED BY: N.R. Simmons	
750 N. Greenfield Pkwy, Corner, NC 27529		Documented by: <i>Natasha Simmons</i> 9/10/2021 Signature: _____ Date: _____ SIG. INVENTORY NO. 03-0977T2

DEFAULT PHASING DIAGRAM

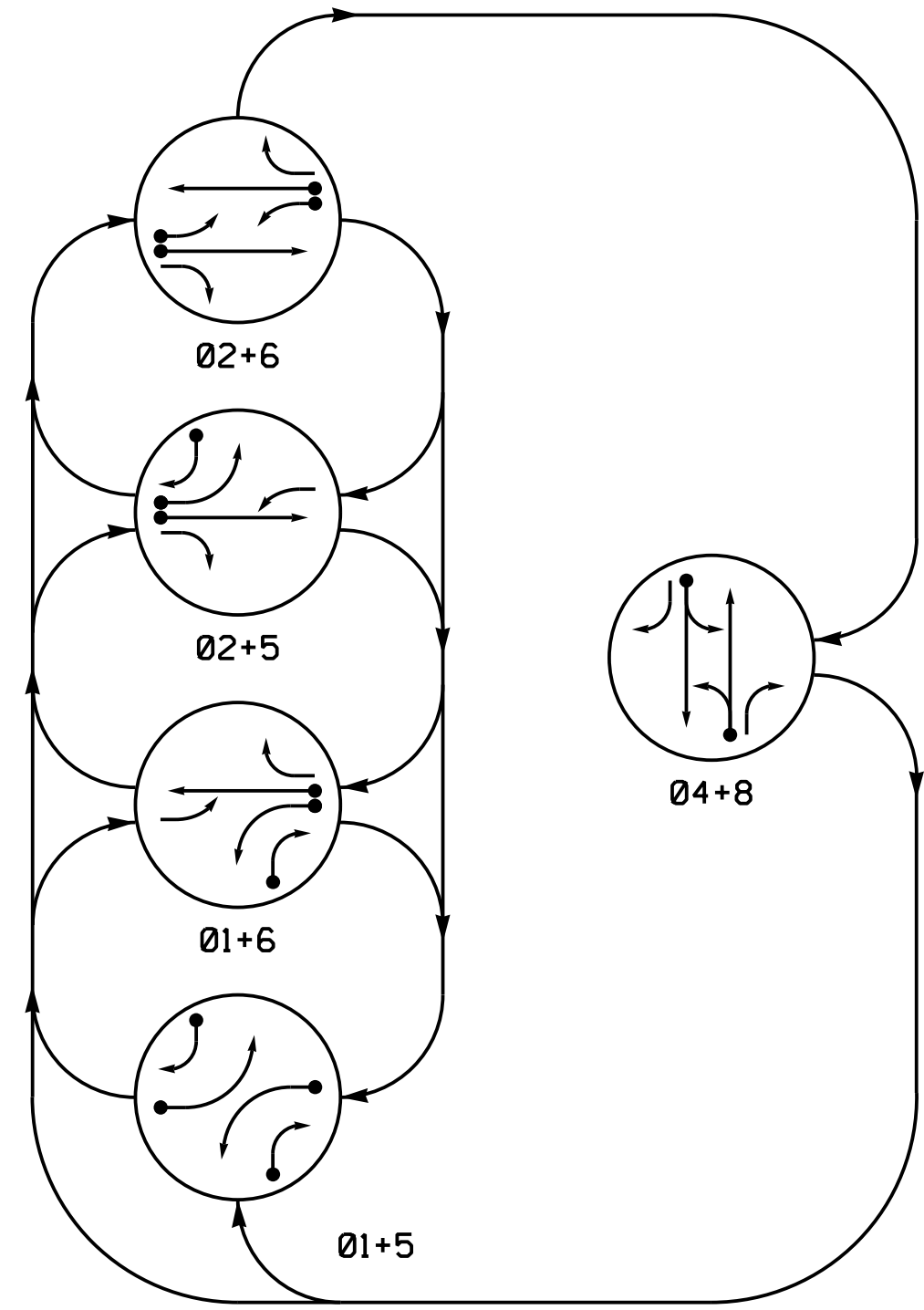

ALTERNATE PHASING DIAGRAM

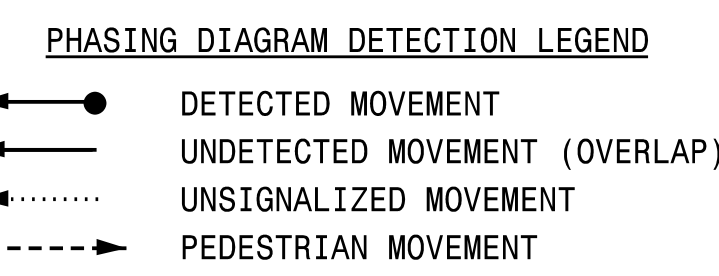
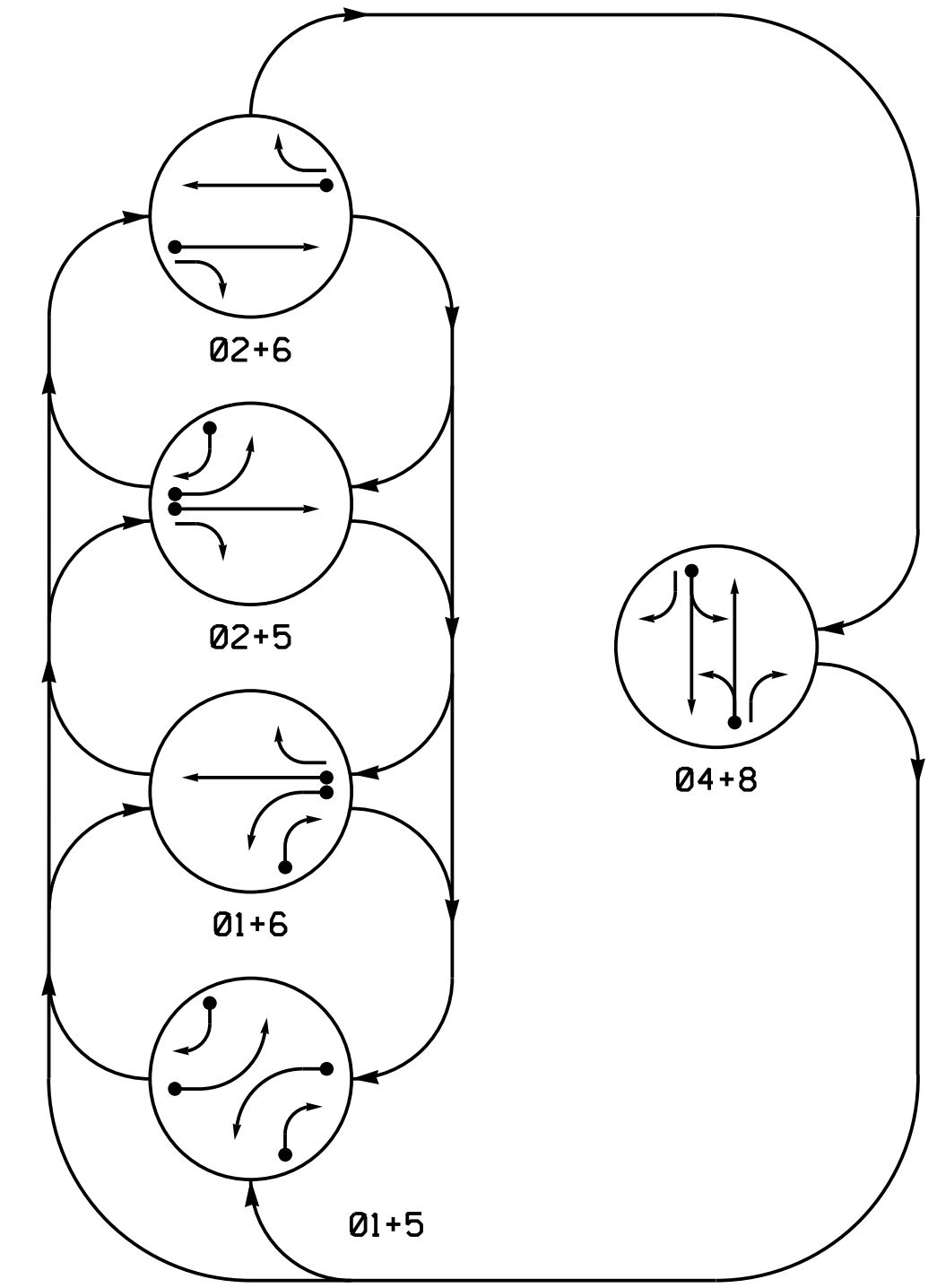

DEFAULT PHASING TABLE OF OPERATION

SIGNAL FACE	PHASE					
	01+5	01+6	02+5	02+6	04+8	F L T
11	—	—	F	F	R	Y
21,22	R	R	G	G	R	Y
41,42	R	R	R	R	G	R
43	F	R	F	R	F	R
51	—	F	—	F	R	Y
61,62	R	G	R	G	R	Y
81,82	R	R	R	R	G	R
83	F	F	R	R	F	R

ALTERNATE PHASING TABLE OF OPERATION

SIGNAL FACE	PHASE					
	01+5	01+6	02+5	02+6	04+8	F L T
11	—	—	R	R	R	Y
21,22	R	R	G	G	R	Y
41,42	R	R	R	R	G	R
43	F	R	F	R	F	R
51	—	R	—	R	R	Y
61,62	R	G	R	G	R	Y
81,82	R	R	R	R	G	R
83	F	F	R	R	F	R

OASIS 2070 LOOP & DETECTOR INSTALLATION CHART

LOOP	SIZE (FT)	DISTANCE FROM STOPBAR (FT)	TURNS	NEW LOOP	DETECTOR PROGRAMMING				SYSTEM LOOP	NEW CARD
					PHASE	CALLING	EXTENSION	FULL TIME DELAY		
1A	6X40	0	*	*	1	Y	Y	-	***15	-
1B	6X40	0	*	*	1	Y	Y	-	-	-
2A	6X6	420	*	*	2	Y	Y	-	-	-
4A	6X40	0	*	*	4	Y	Y	-	-	-
5A	6X40	0	*	*	5	Y	Y	-	***15	-
5B	6X40	0	*	*	5	Y	Y	-	-	-
6A	6X6	420	*	*	6	Y	Y	-	-	-
8A	6X40	0	*	*	8	Y	Y	-	-	-

* Multizone Microwave Detection.
 ** Disable phase 2 and 6 call for 1A and 5A during alternate phasing operation.
 *** Reduce delay to 0 seconds during alternate phasing operation.

5 Phase Fully Actuated Isolated

NOTES

- Refer to "Roadway Standard Drawings NCDOT" dated January 2018 and "Standard Specifications for Roads and Structures" dated January 2018.
- Do not program signal for late night flashing operation unless otherwise directed by the Engineer.
- Phase 1 and/or phase 5 may be lagged.
- Reposition existing signal heads numbered 11,21,22,41,51, and 81.
- Set all detector units to presence mode.
- The Division Traffic Engineer will determine the hours of use for each phasing plan.
- Incorporate Microwave Detection system for vehicle detection.
- Provide the Engineer with the Manufacturer's approved Microwave Detection locations and mounting heights to obtain detection zones as shown.

SIGNAL FACE I.D.

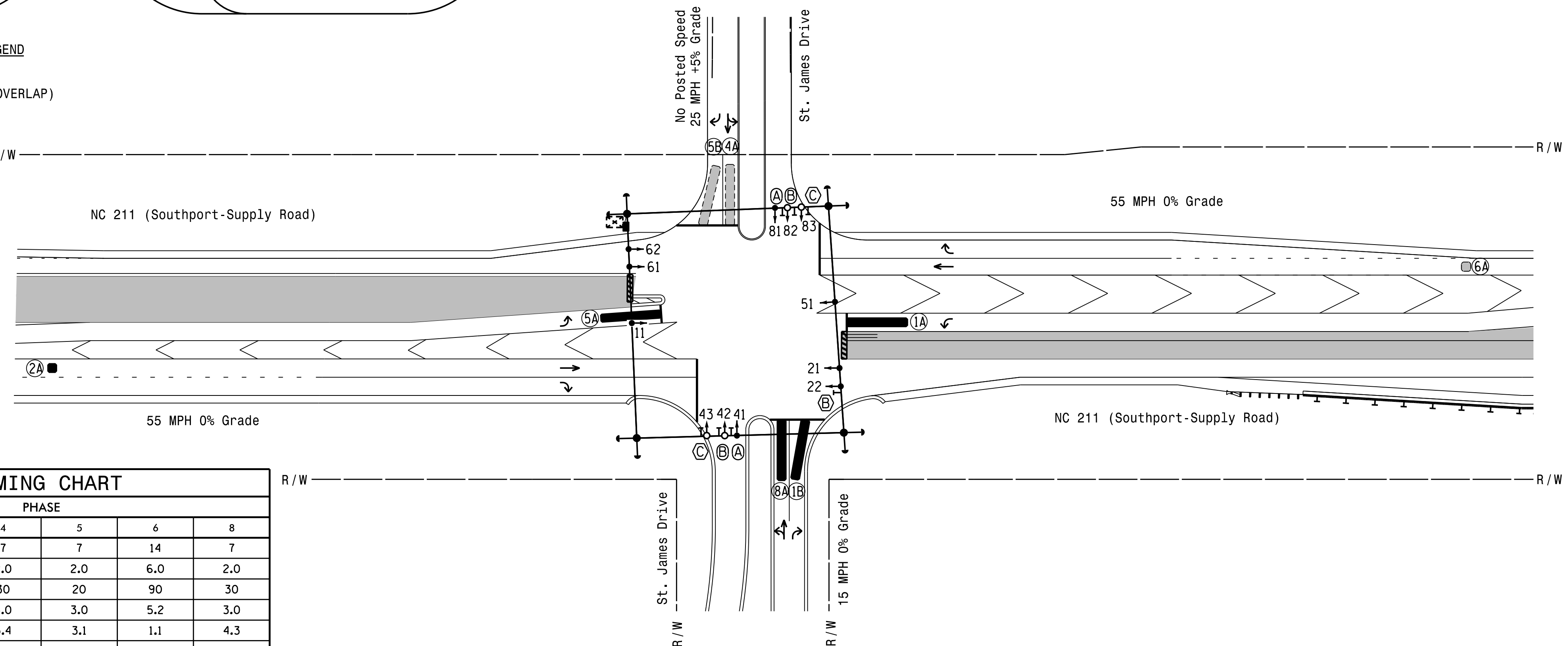
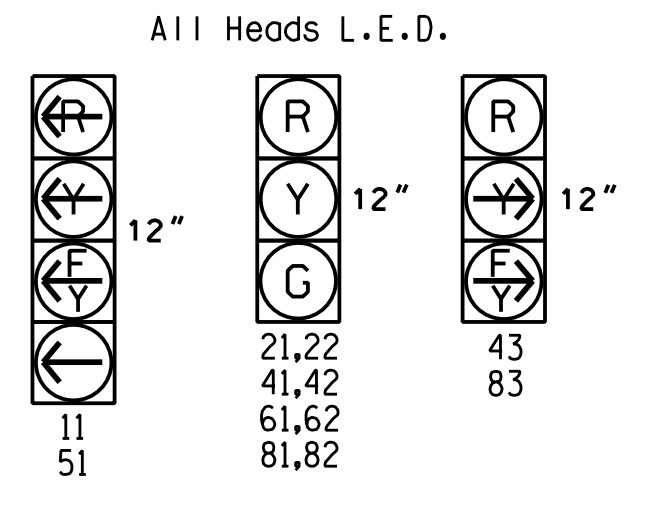

OASIS 2070 TIMING CHART

FEATURE	PHASE					
	1	2	4	5	6	8
Min Green 1 *	7	14	7	7	14	7
Extension 1 *	2.0	6.0	2.0	2.0	6.0	2.0
Max Green 1 *	20	90	30	20	90	30
Yellow Clearance	3.0	5.2	3.0	3.0	5.2	3.0
Red Clearance	3.1	1.1	3.4	3.1	1.1	4.3
Red Revert	2.0	2.0	2.0	2.0	2.0	2.0
Walk 1 *	-	-	-	-	-	-
Don't Walk 1	-	-	-	-	-	-
Seconds Per Actuation *	-	2.5	-	-	2.5	-
Max Variable Initial *	-	46	-	-	46	-
Time Before Reduction *	-	15	-	-	15	-
Time To Reduce *	-	30	-	-	30	-
Minimum Gap	-	3.0	-	-	3.0	-
Recall Mode	-	MIN RECALL	-	-	MIN RECALL	-
Vehicle Call Memory	-	YELLOW	-	-	YELLOW	-
Dual Entry	-	-	ON	-	-	ON
Simultaneous Gap	ON	ON	ON	ON	ON	ON

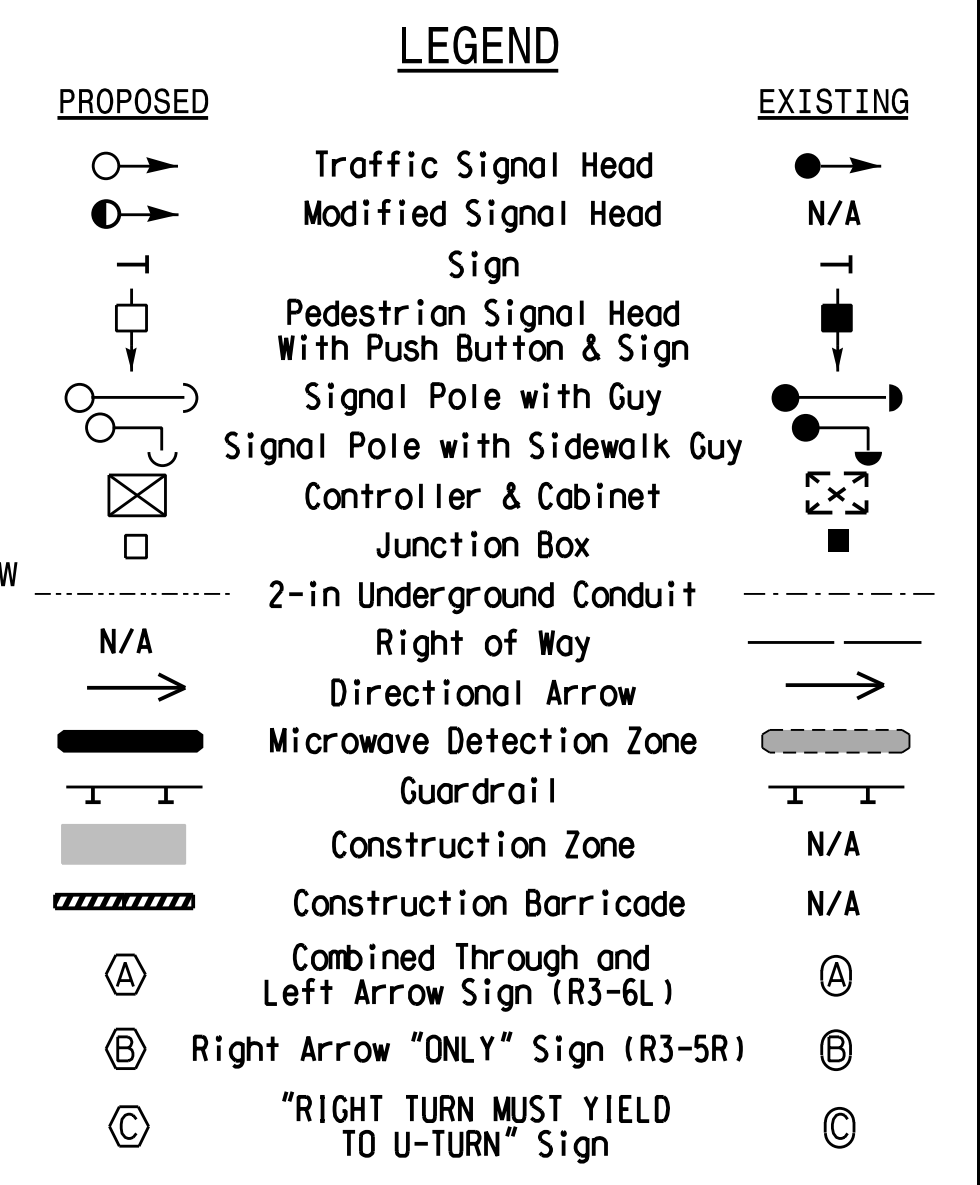

Signal Upgrade
 Temporary Design 3
 Construction Phase 3

DOCUMENT NOT CONSIDERED FINAL UNLESS ALL SIGNATURES COMPLETED

<p>HNTB NORTH CAROLINA, P.C. 343 E. Six Forks Road, Suite 200 Raleigh, North Carolina 27609 NC License No: C-1554 (919) 546-8997</p>	NC 211 (Southport-Supply Road) at St. James Drive Division 03 Brunswick Co. Southport PLAN DATE: June 2017 REVIEWED BY: A.D. Klinksiek PREPARED BY: A.H. Thornburg REVIEWED BY: N.R. Simmons	SEAL N. R. Simmons ENGINEER 031464 9/10/2021
	REVISIONS INIT. DATE SIGNATURE DATE SIG. INVENTORY NO. 03-097773	